

# [CONTENTS]

## ○ SECTION 1.GENERAL

- SERVICING PRECAUTIONS ..... 1-2
- ESD PRECAUTIONS ..... 1-4

## ○ SECTION 2.ELECTRICAL SECTION

- TROUBLESHOOTING GUIDE ..... 2-1
- BLOCK DIAGRAM ..... 2-11
- SCHEMATIC DIAGRAMS ..... 2-13
- WIRING DIAGRAM ..... 2-27
- PRINTED CIRCUIT BOARD DIAGRAM ..... 2-29

## ○ SECTION 3.DVD PART

- DVD ELECTRICAL TROUBLESHOOTING GUIDE ..... 3-1
- INTERNAL BLOCK DIAGRAM of ICs ..... 3-7
- SCHEMATIC DIAGRAM ..... 3-27
- PRINTED CIRCUIT BOARD DIAGRAM ..... 3-33

## ○ SECTION 4. EXPLODED VIEWS

- CABINET AND MAIN FRAME SECTION ..... 4-1
- TAPE DECK MECHANISM (A/R & A/S : LEFT A/S DECK) ..... 4-5
- TAPE DECK MECHANISM (A/R & A/S : RIGHT A/R DECK) ..... 4-7

## ○ SECTION 5. SPEAKER PART .....5-1

## ○ SECTION 6. REPLACEMENT PARTS LIST .....6-1

# SECTION 1. GENERAL

## ☐ SERVICING PRECAUTIONS

### NOTES REGARDING HANDLING OF THE PICK-UP

#### 1. Notes for transport and storage

- 1) The pick-up should always be left in its conductive bag until immediately prior to use.
- 2) The pick-up should never be subjected to external pressure or impact.

Storage in conductive bag

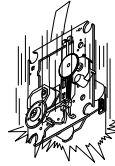
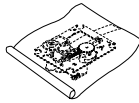

Drop impact

#### 2. Repair notes

- 1) The pick-up incorporates a strong magnet, and so should never be brought close to magnetic materials.
- 2) The pick-up should always be handled correctly and carefully, taking care to avoid external pressure and impact. If it is subjected to strong pressure or impact, the result may be an operational malfunction and/or damage to the printed-circuit board.
- 3) Each and every pick-up is already individually adjusted to a high degree of precision, and for that reason the adjustment point and installation screws should absolutely never be touched.
- 4) Laser beams may damage the eyes!  
Absolutely never permit laser beams to enter the eyes!  
Also NEVER switch ON the power to the laser output part (lens, etc.) of the pick-up if it is damaged.

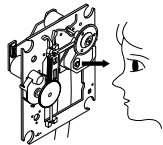

NEVER look directly at the laser beam, and don't let contact fingers or other exposed skin.

#### 5) Cleaning the lens surface

If there is dust on the lens surface, the dust should be cleaned away by using an air bush (such as used for camera lens). The lens is held by a delicate spring. When cleaning the lens surface, therefore, a cotton swab should be used, taking care not to distort this.

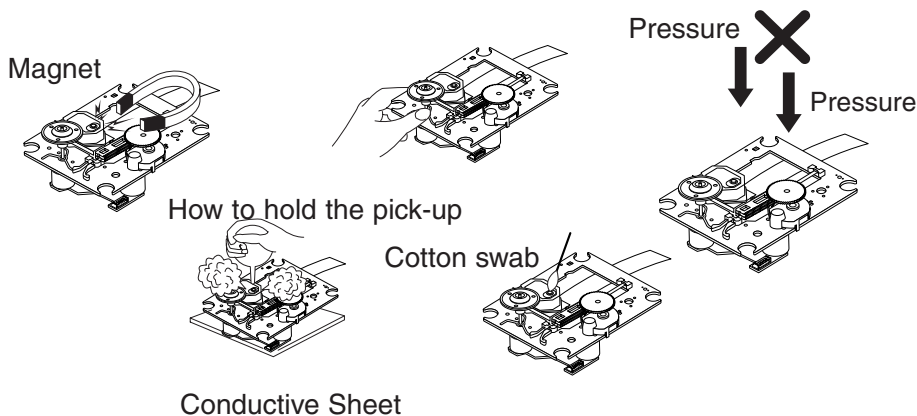

#### 6) Never attempt to disassemble the pick-up.

Spring by excess pressure. If the lens is extremely dirty, apply isopropyl alcohol to the cotton swab. (Do not use any other liquid cleaners, because they will damage the lens.) Take care not to use too much of this alcohol on the swab, and do not allow the alcohol to get inside the pick-up.

# NOTES REGARDING COMPACT DISC PLAYER REPAIRS

## 1. Preparations

- 1) Compact disc players incorporate a great many ICs as well as the pick-up (laser diode). These components are sensitive to, and easily affected by, static electricity. If such static electricity is high voltage, components can be damaged, and for that reason components should be handled with care.
- 2) The pick-up is composed of many optical components and other high-precision components. Care must be taken, therefore, to avoid repair or storage where the temperature of humidity is high, where strong magnetism is present, or where there is excessive dust.

## 2. Notes for repair

- 1) Before replacing a component part, first disconnect the power supply lead wire from the unit
- 2) All equipment, measuring instruments and tools must be grounded.
- 3) The workbench should be covered with a conductive sheet and grounded.  
When removing the laser pick-up from its conductive bag, do not place the pick-up on the bag. (This is because there is the possibility of damage by static electricity.)
- 4) To prevent AC leakage, the metal part of the soldering iron should be grounded.
- 5) Workers should be grounded by an armband (1M  $\Omega$ )
- 6) Care should be taken not to permit the laser pick-up to come in contact with clothing, in order to prevent static electricity changes in the clothing to escape from the armband.
- 7) The laser beam from the pick-up should NEVER be directly facing the eyes or bare skin.

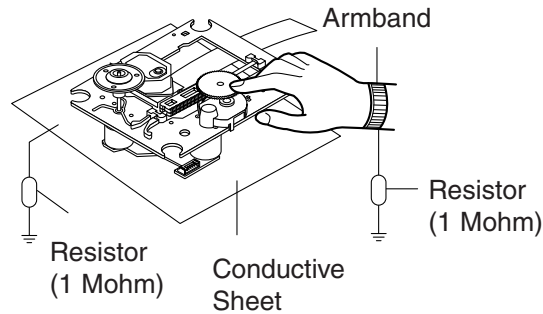

## CLEARING MALFUNCTION

You can reset your unit to initial status if malfunction occur(button malfunction, display, etc.). Using a pointed good conductor(such as driver), simply short the RESET jump wire on the inside of the volume knob for more than 3 seconds.  
If you reset your unit, you must reenter all its settings(stations, clock, timer)

- NOTE:** 1. To operate the RESET jump wire, pull the volume rotary knob and release it.  
2. If you wish to operate the RESET jump wire, it is necessary to unplug the power cord.

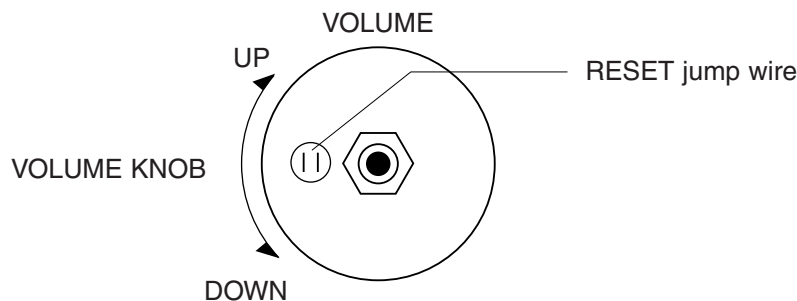

## □ ESD PRECAUTIONS

### Electrostatically Sensitive Devices (ESD)



Some semiconductor (solid state) devices can be damaged easily by static electricity. Such components commonly are called Electrostatically Sensitive Devices (ESD). Examples of typical ESD devices are integrated circuits and some field-effect transistors and semiconductor chip components. The following techniques should be used to help reduce the incidence of component damage caused by static electricity.

1. Immediately before handling any semiconductor component or semiconductor-equipped assembly, drain off any electrostatic charge on your body by touching a known earth ground. Alternatively, obtain and wear a commercially available discharging wrist strap device, which should be removed for potential shock reasons prior to applying power to the unit under test.
2. After removing an electrical assembly equipped with ESD devices, place the assembly on a conductive surface such as aluminum foil, to prevent electrostatic charge buildup or exposure of the assembly.
3. Use only a grounded-tip soldering iron to solder or unsolder ESD devices.
4. Use only an anti-static solder removal device. Some solder removal devices not classified as "anti-static" can generate electrical charges sufficient to damage ESD devices.
5. Do not use freon-propelled chemicals. These can generate electrical charges sufficient to damage ESD devices.
6. Do not remove a replacement ESD device from its protective package until immediately before you are ready to install it. (Most replacement ESD devices are packaged with leads electrically shorted together by conductive foam, aluminum foil or comparable conductive materials).
7. Immediately before removing the protective material from the leads of a replacement ESD device, touch the protective material to the chassis or circuit assembly into which the device will be installed.

**CAUTION : BE SURE NO POWER IS APPLIED TO THE CHASSIS OR CIRCUIT, AND OBSERVE ALL OTHER SAFETY PRECAUTIONS.**

8. Minimize bodily motions when handing unpackaged replacement ESD devices. (Otherwise harmless motion such as the brushing together of your clothes fabric or the lifting of your foot from a carpeted floor can generate static electricity sufficient to damage an ESD device).

### CAUTION. GRAPHIC SYMBOLS

	THE LIGHTNING FLASH WITH APOWHEAD SYMBOL, WITHIN AN EQUILATERAL TRIANGLE, IS INTENDED TO ALERT THE SERVICE PERSONNEL TO THE PRESENCE OF UNINSULATED "DANGEROUS VOLTAGE" THAT MAY BE OF SUFFICIENT MAGNITUDE TO CONSTITUTE A RISK OF ELECTRIC SHOCK.
	THE EXCLAMATION POINT WITHIN AN EQUILATERAL TRIANGLE IS INTENDED TO ALERT THE SERVICE PERSONNEL TO THE PRESENCE OF IMPORTANT SAFETY INFORMATION IN SERVICE LITERATURE.

# MEMO

A series of horizontal dotted lines for writing.

# SECTION 2. ELECTRICAL

## □ TROUBLESHOOTING GUIDE

### P-SENS CHECK

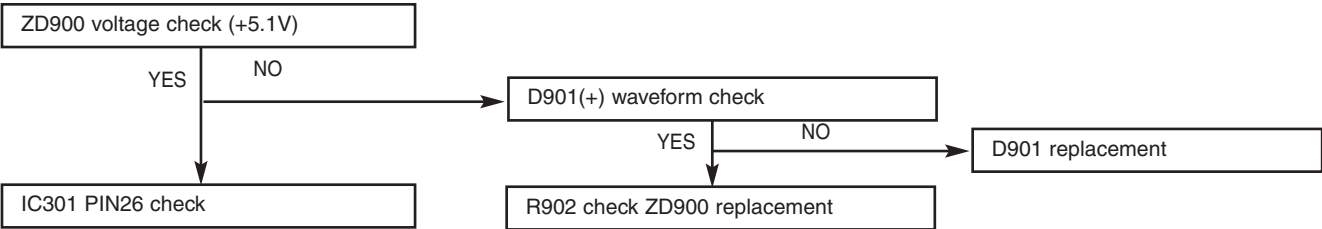

### VKK CHECK

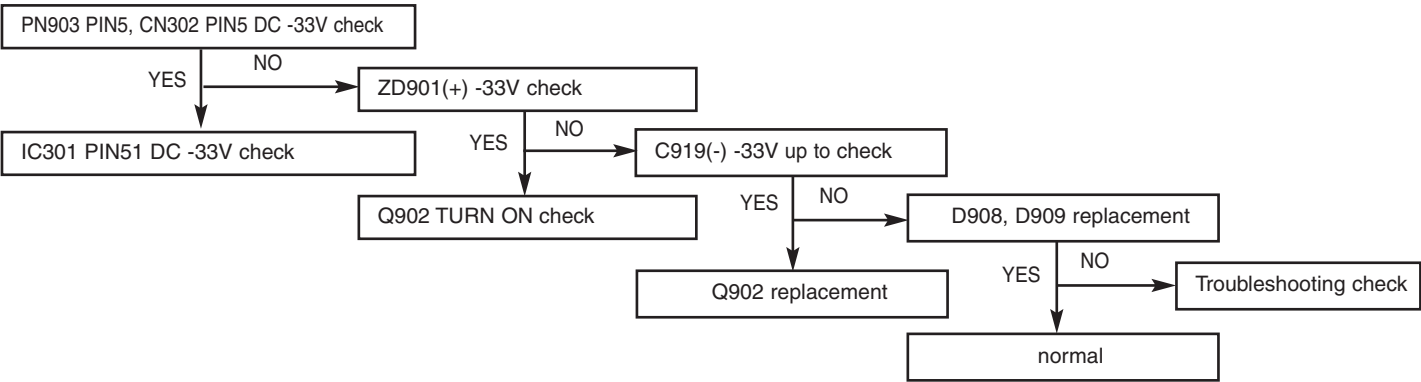

## POWER CHECK

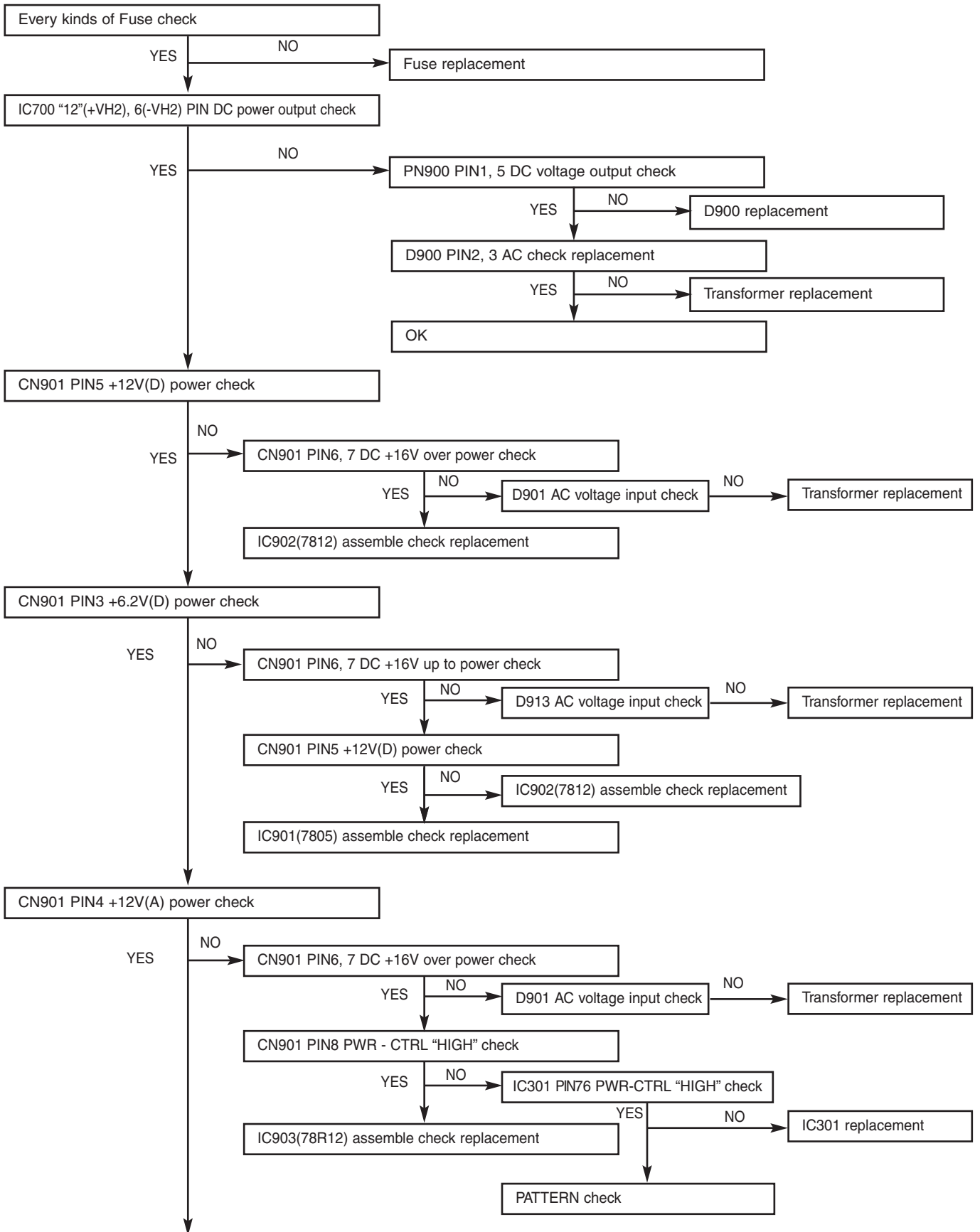

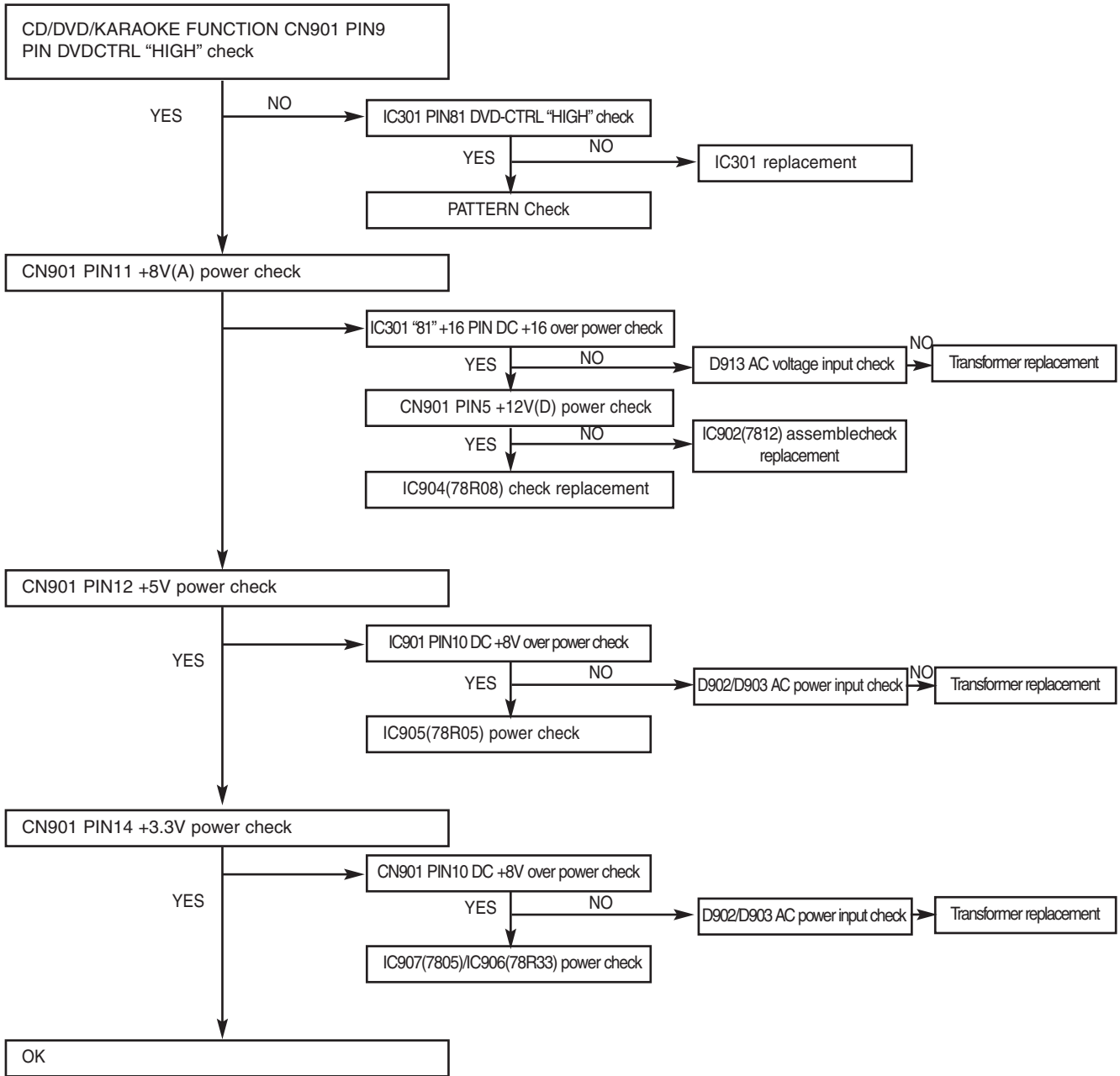



## Muting circuit Troubleshooting (if MUTE)

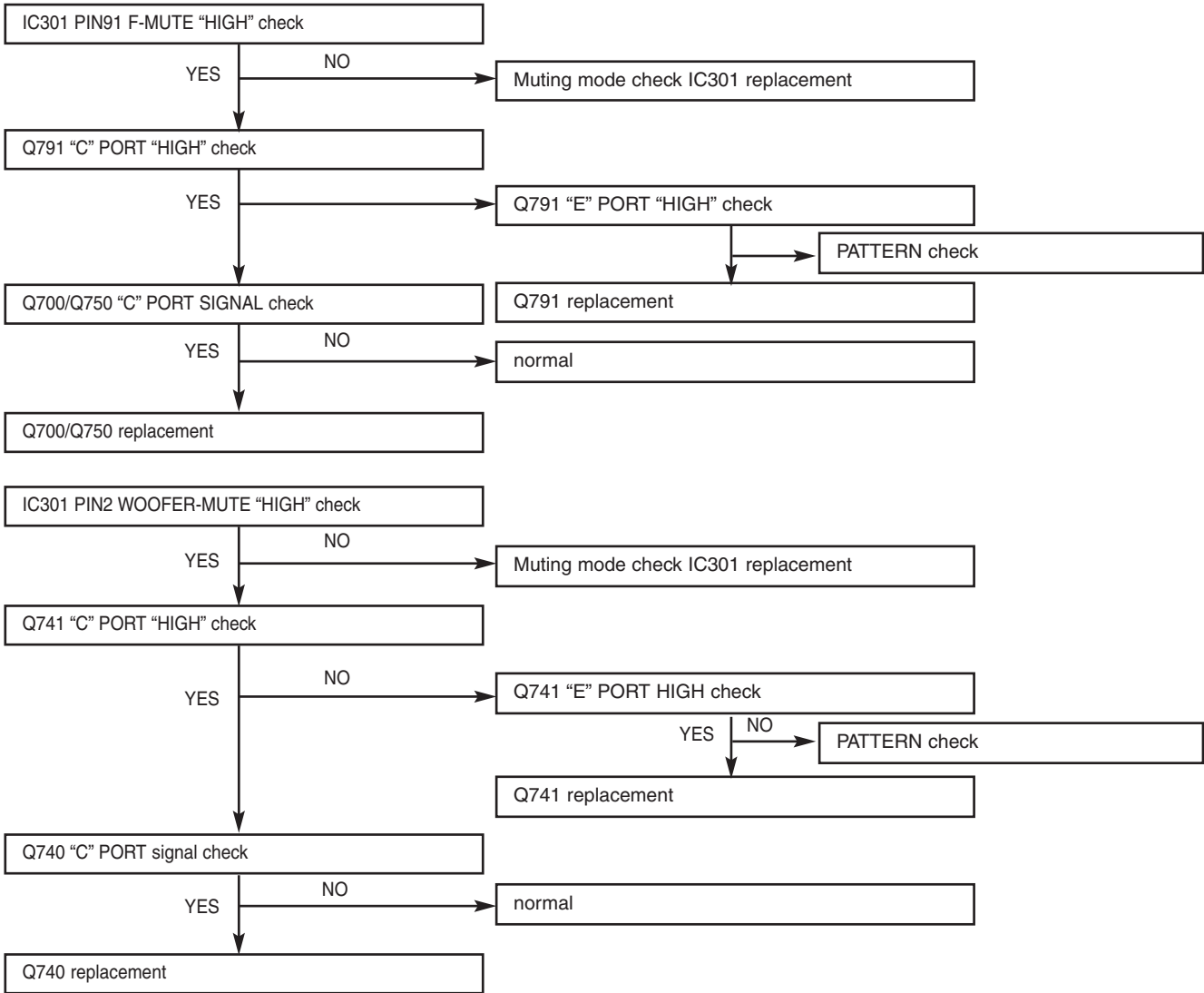

**no sound**

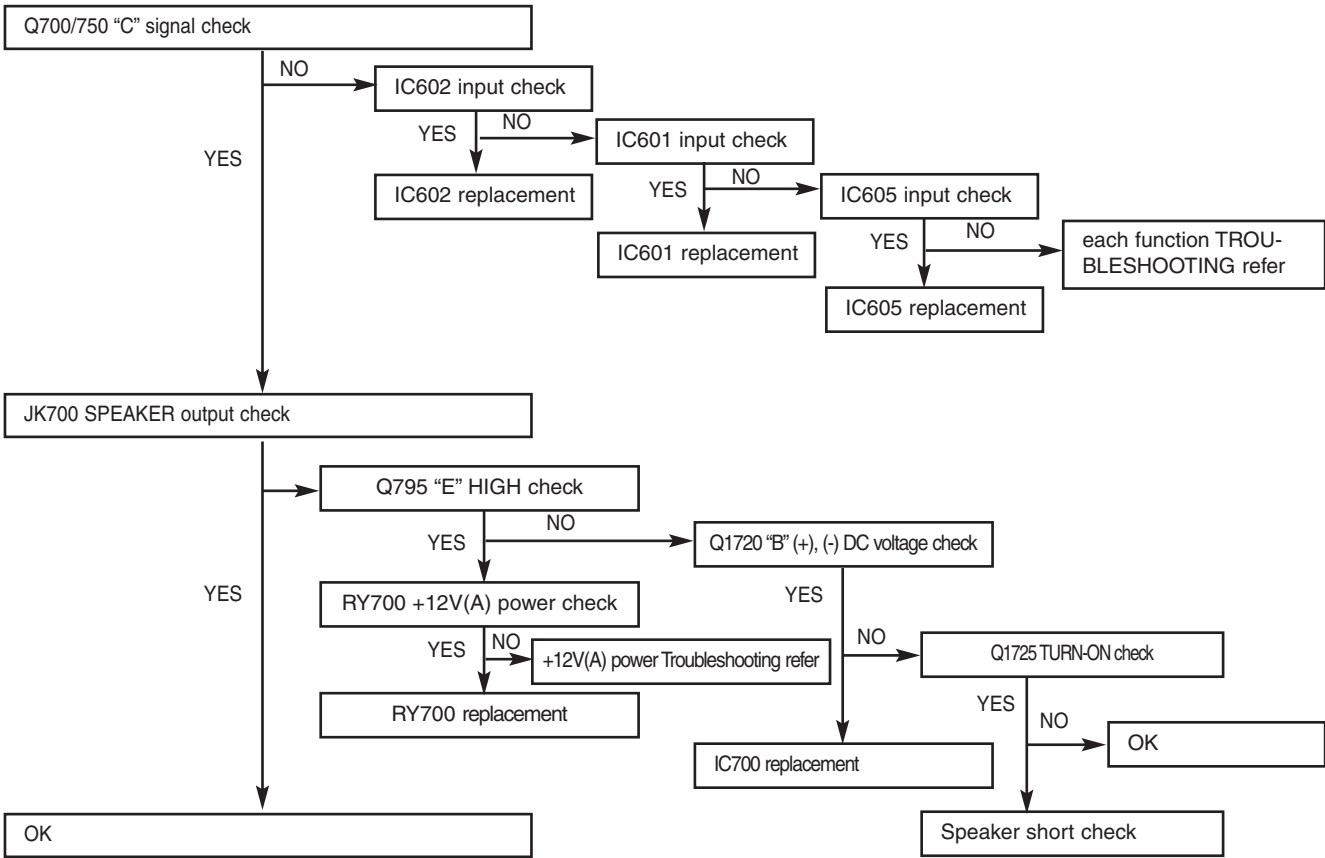

**Specific FUNCTION MODE has no sound**

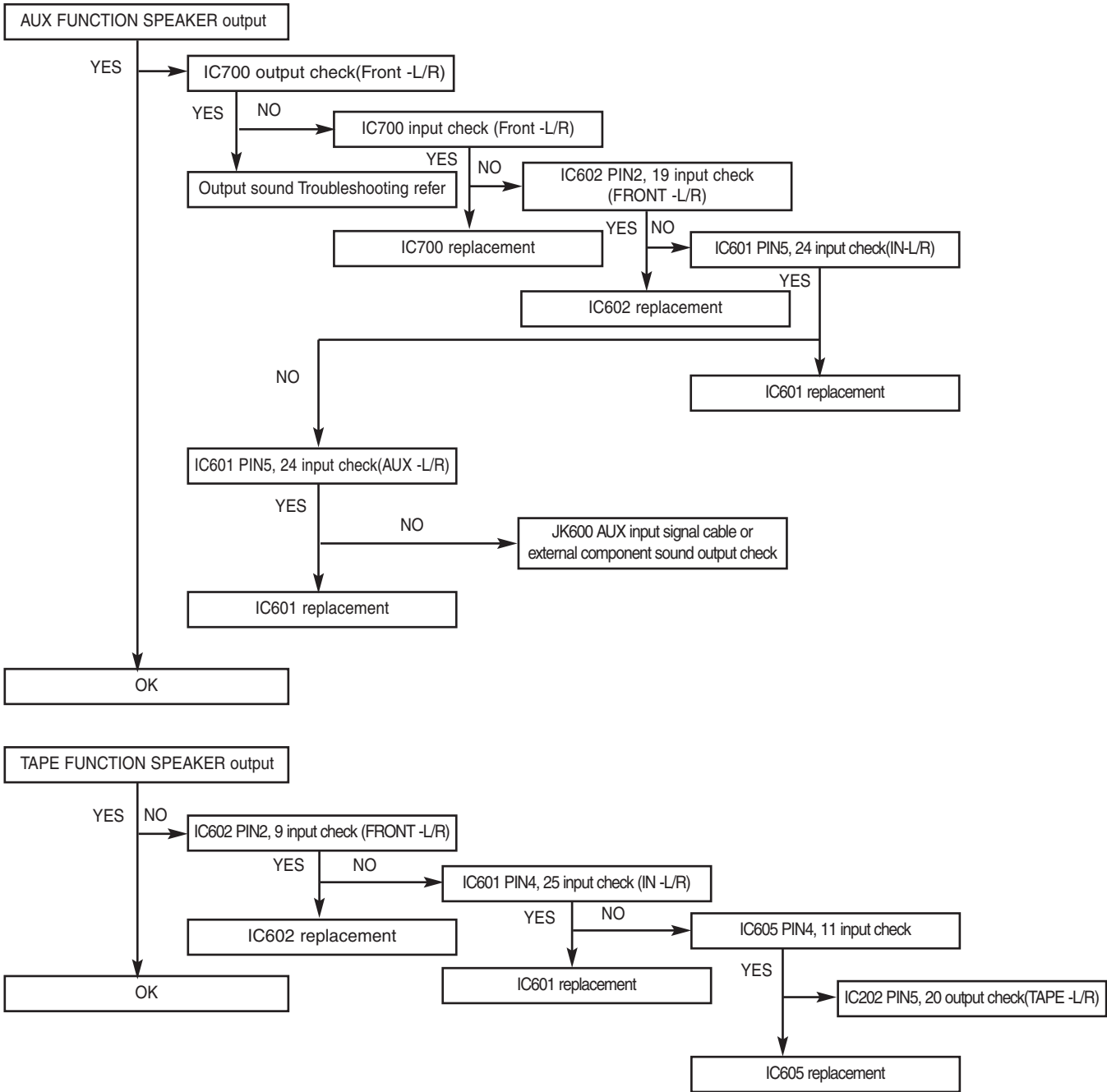

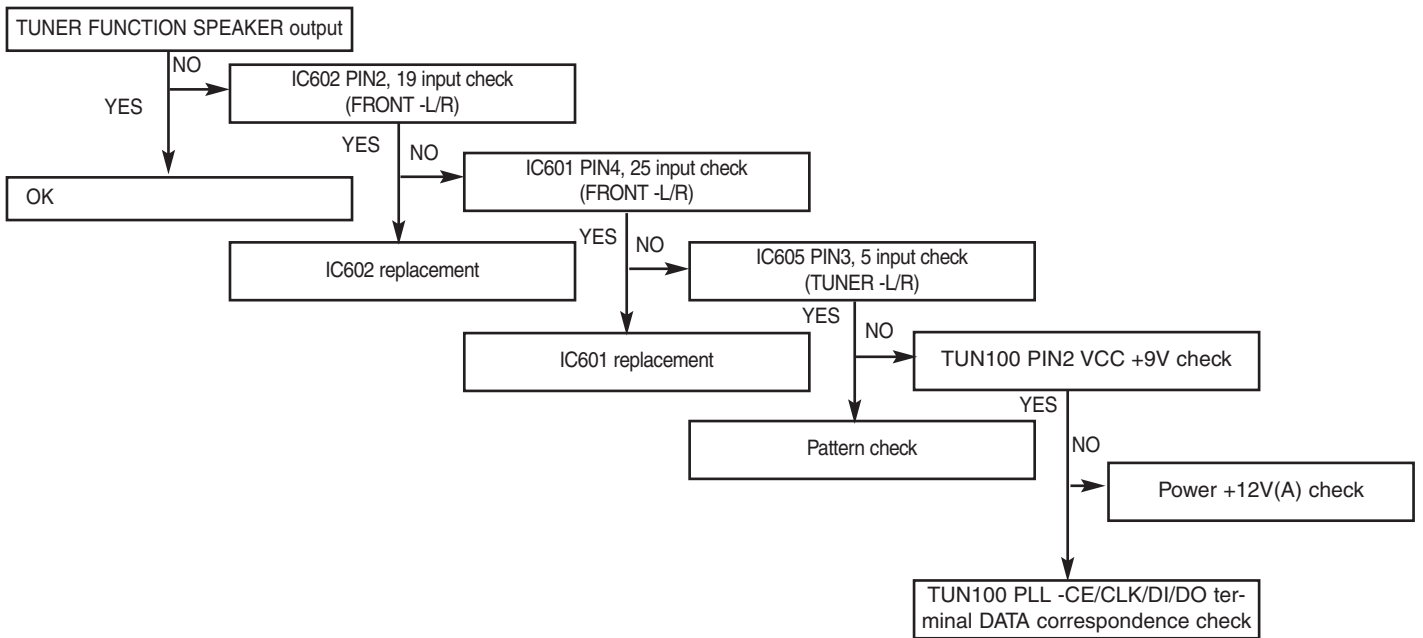
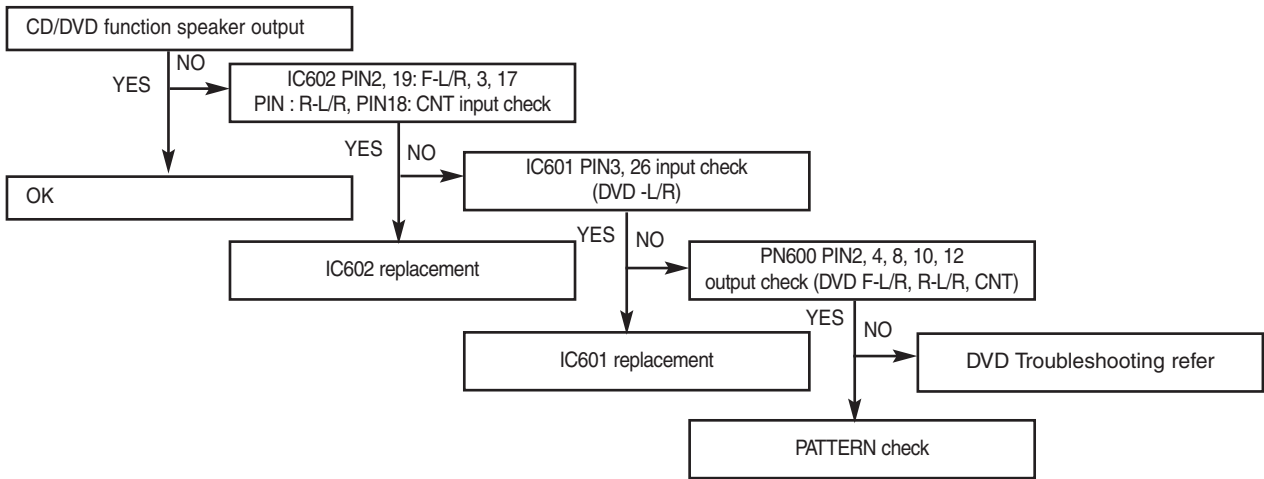

### IC301 U-COM IC Troubleshooting

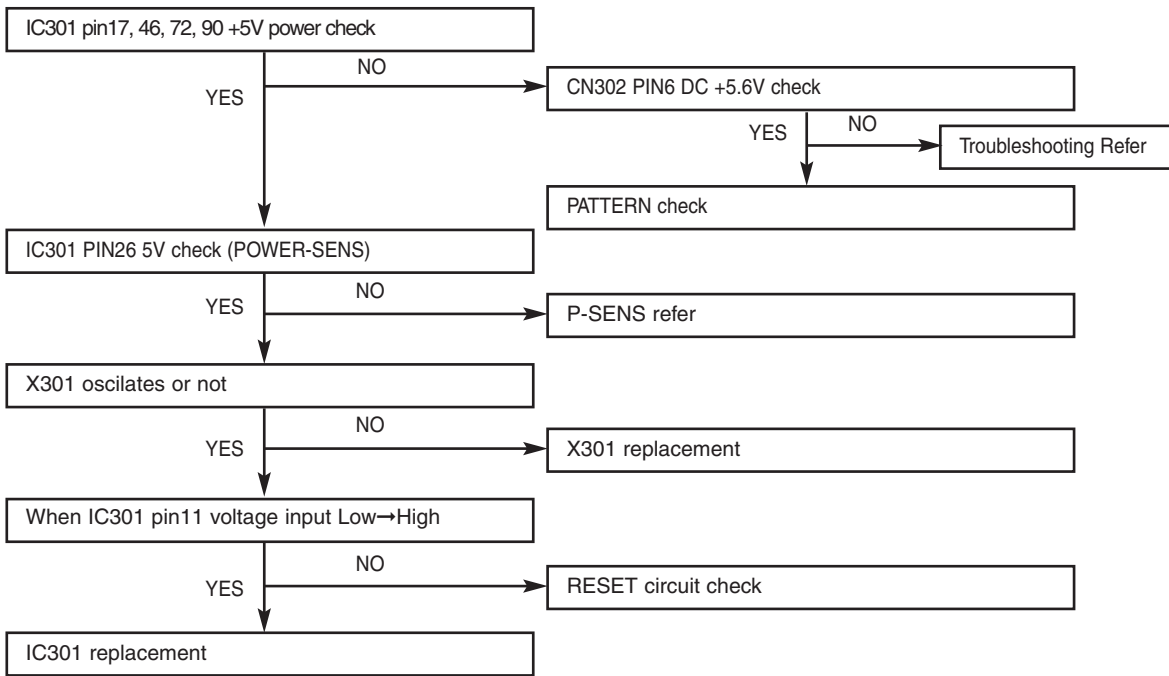

### IC501(EXPENDER IC) Troubleshooting

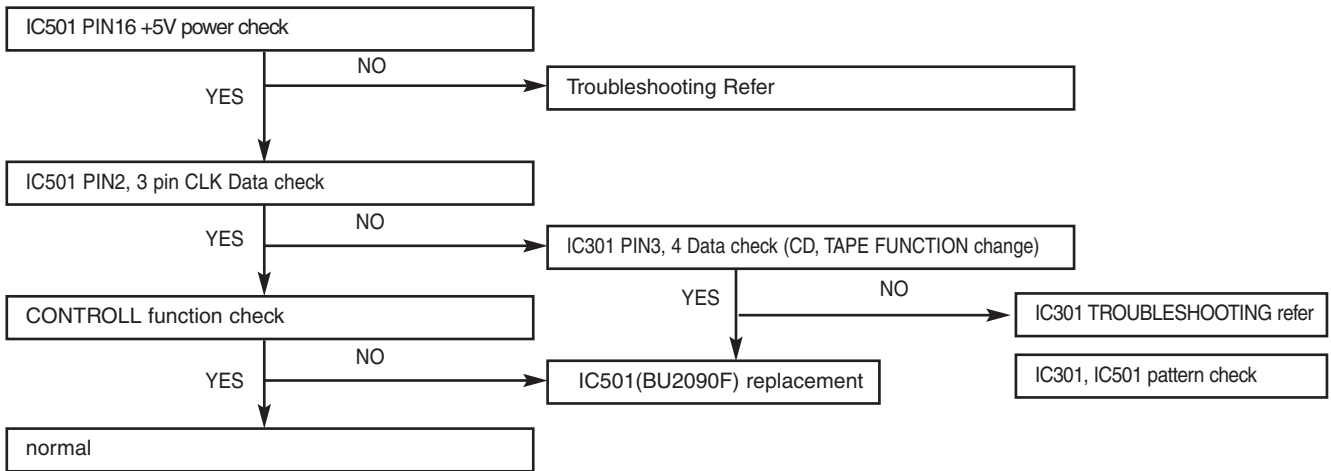

## IC700(AMP IC) Troubleshooting

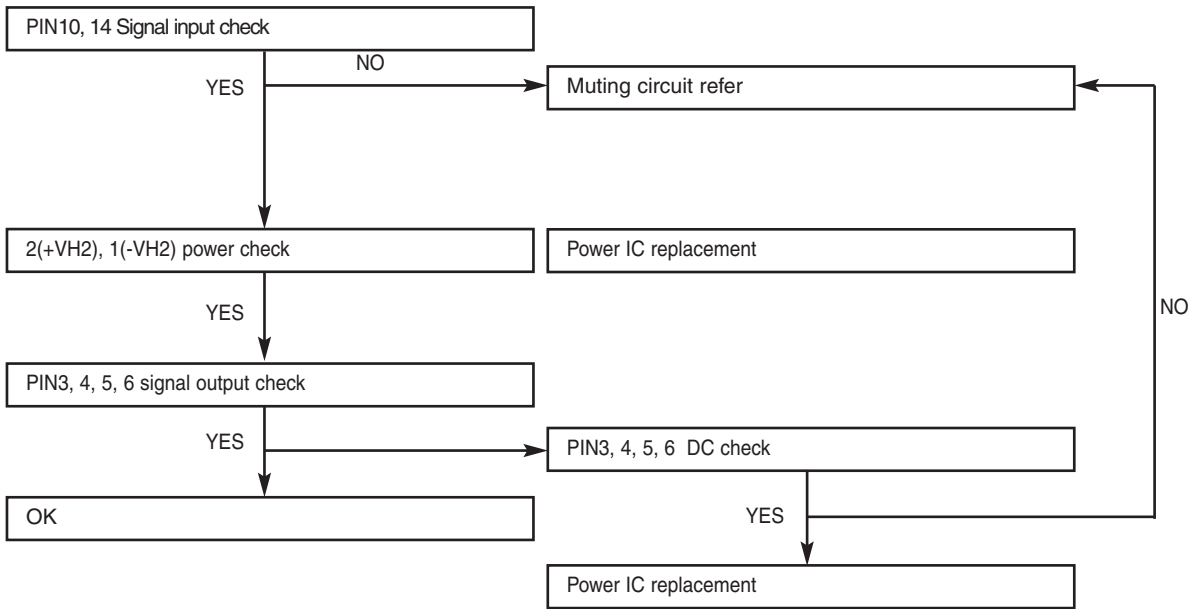

## TAPE PLAY

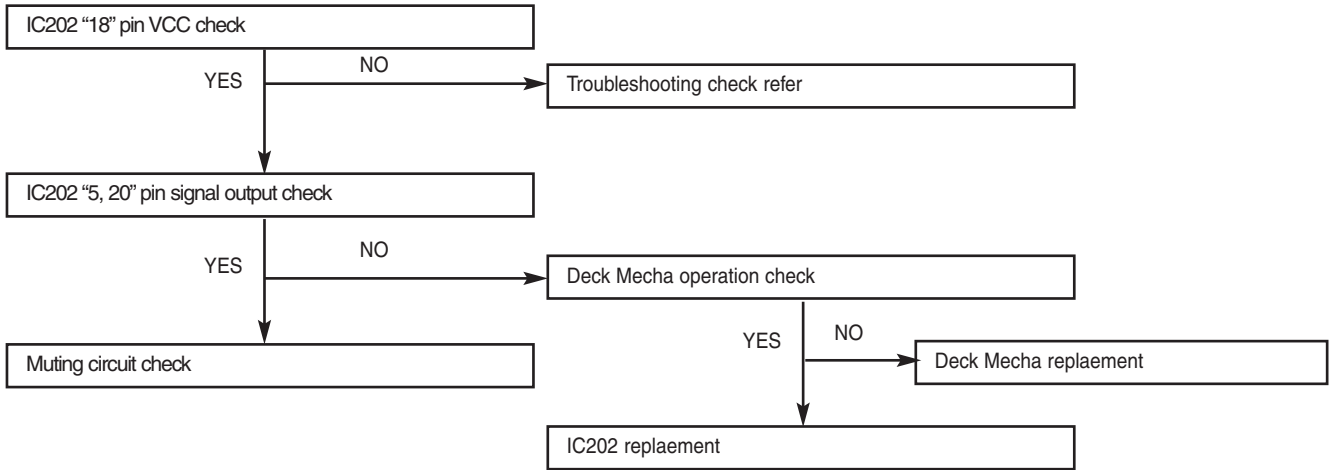

**TAPE REC check (A252, Q202 On: R273, R223 High)**

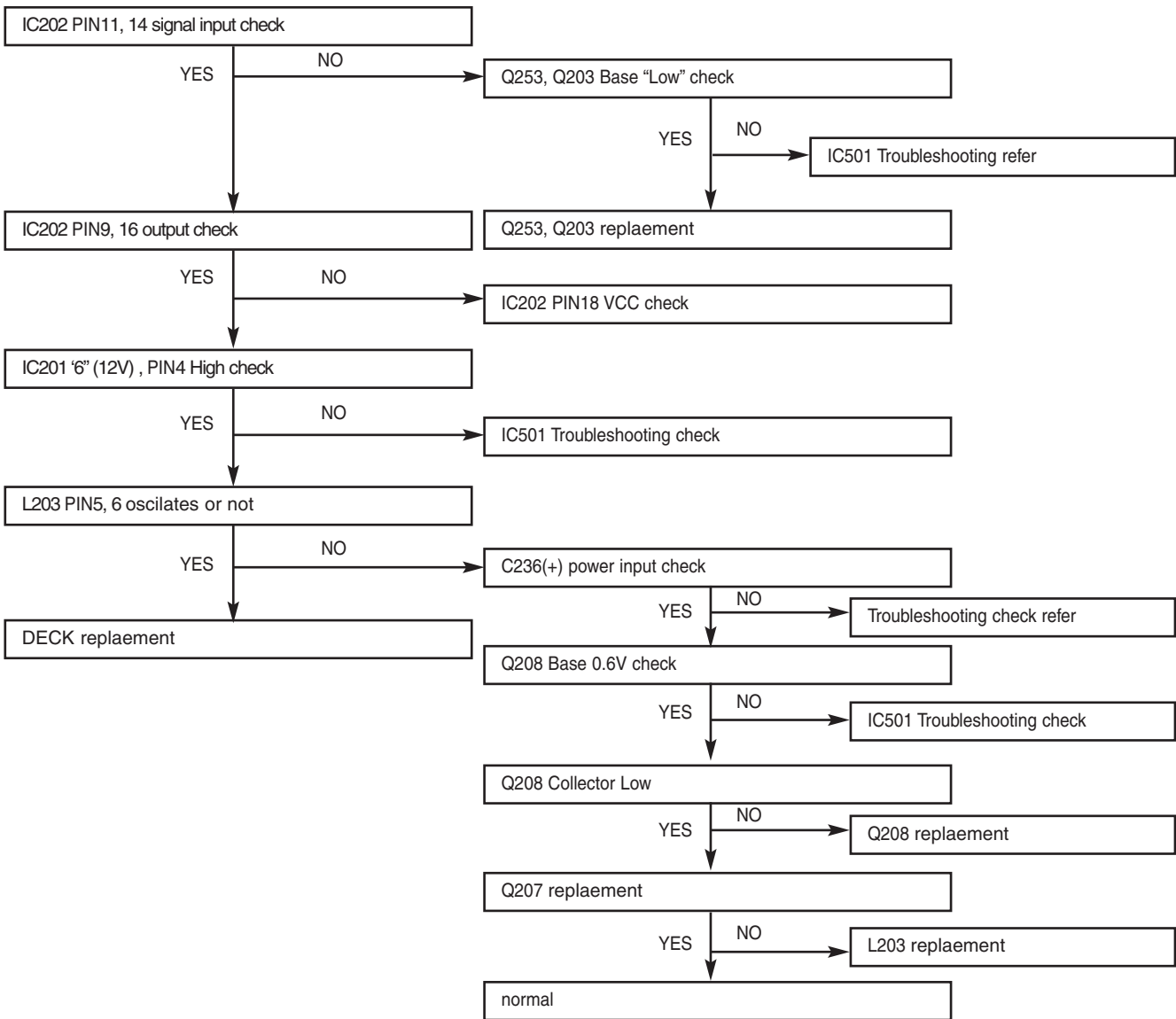

**Dubbing check ("NORMAL" or "HIGH") check**

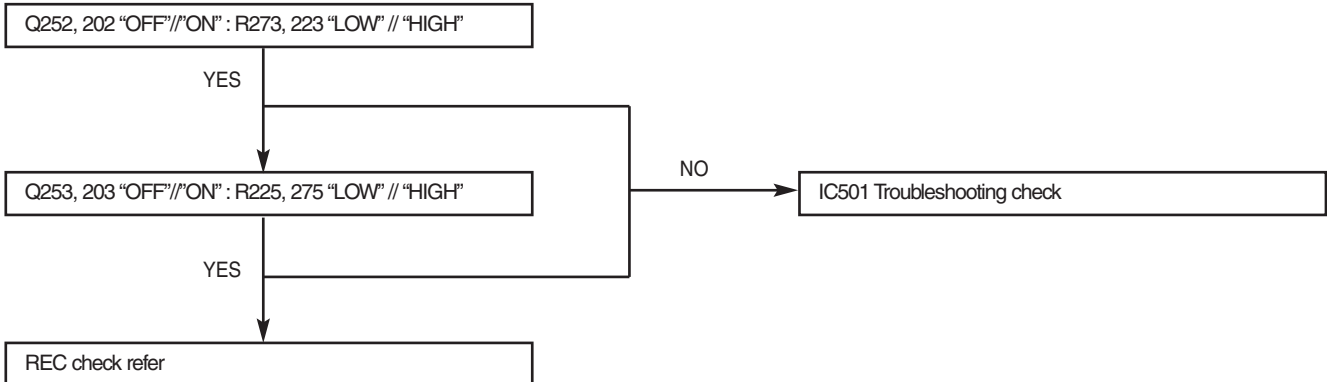

# □ BLOCK DIAGRAM

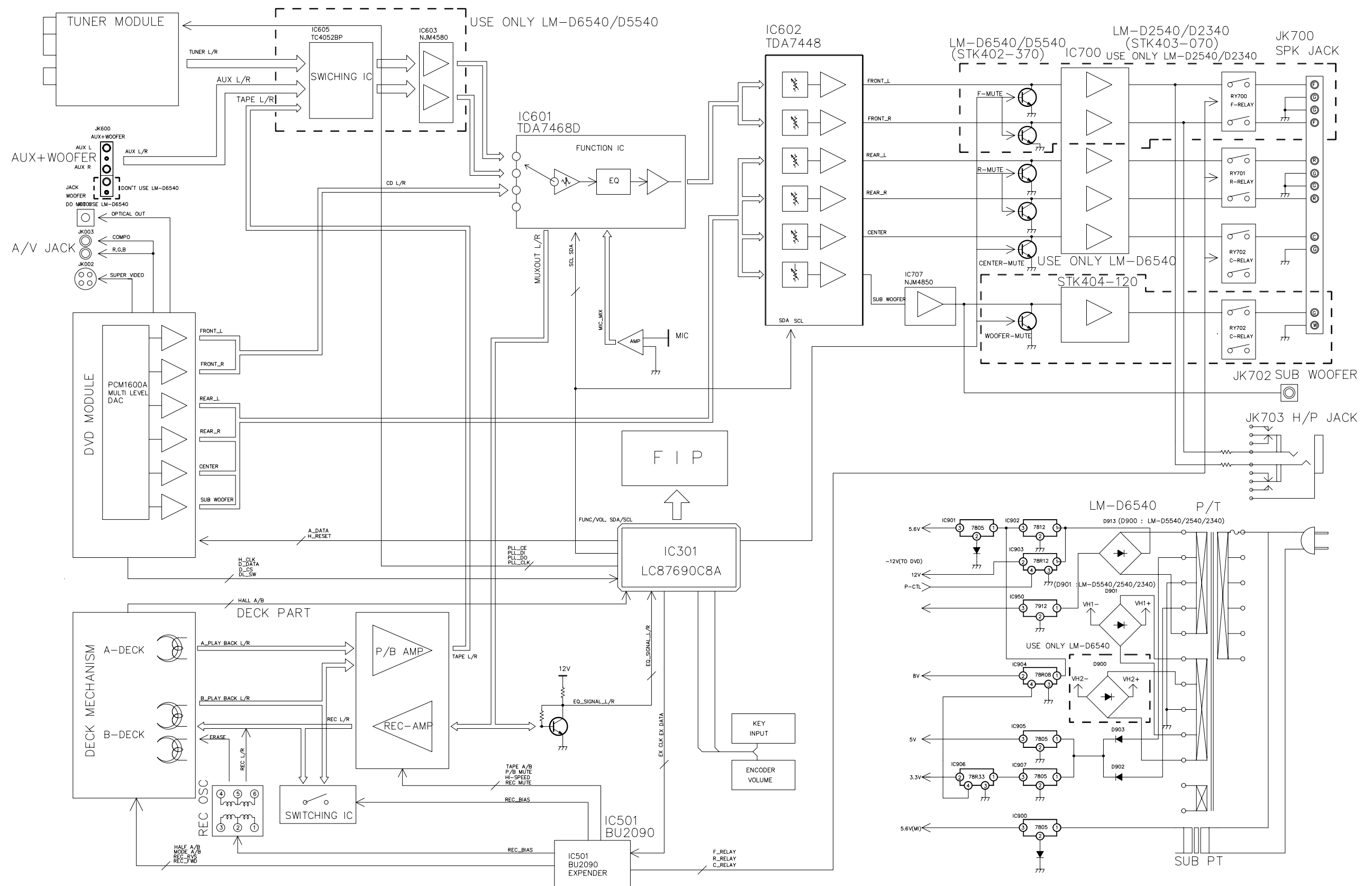

BLOCK DIAGRAM  
LM-D6540/D5540/D2540/D2340  
3854R12568A



# SCHEMATIC DIAGRAMS

## MAIN SCHEMATIC DIAGRAM

### LOCATION GUIDE

C110	C4	Q660	C8
C451	N11	R451	M11
C452	M11	R452	M11
C453	L10	R453	L10
C455	L11	R456	M10
C458	L8	R458	K8
C461	N9	R459	K9
C462	M9	R461	M9
C463	L9	R462	M9
C464	M8	R463	L9
C465	L9	R464	M8
C601	F7	R465	N9
C602	F7	R466	M9
C603	F7	R600	C12
C604	F7	R601	C11
C605	C7	R602	E6
C606	C7	R603	B9
C607	C7	R605	F6
C608	C7	R606	F6
C609	F6	R607	G6
C610	G6	R608	G6
C611	G6	R609	H6
C612	G6	R610	H6
C613	H6	R613	C9
C614	C11	R614	C9
C615	K5	R615	C9
C619	C9	R618	C4
C620	C3	R619	C4
C622	E8	R620	B9
C623	E7	R621	C7
C624	E7	R622	G6
C625	G8	R623	C5
C627	K7	R624	K5
C630	K6	R631	E8
C631	L5	R635	G7
C640	L9	R638	G9
C645	E8	R639	H7
C647	E7	R640	H7
C651	F8	R641	B9
C652	F8	R643	M5
C653	F8	R644	M6
C654	F8	R650	C11
C655	G8	R651	D11
C656	G8	R652	E11
C657	G8	R653	C9
C658	G8	R655	F10
C659	E11	R656	F10
C660	G11	R657	G11
C661	G11	R658	G11
C662	C11	R659	H11
C663	H11	R660	H11
C664	C11	R663	C8
C665	K7	R670	B9
C669	L5	R671	C7
C671	C8	R672	C6
C690	E8	R673	M7
CN300	G1	R674	K7
D601	M7	R675	K6
D970	E12	R676	C8
D9701	E11	R677	C8
IC450	M11	R678	C6
IC601	F8	R679	C7
IC602	K6	R688	C4
JK600	B12	R691	B8
PN600	B7	SW2	P3
Q451	L10	TUN100	B4
Q461	M8	ZD601	E7
Q462	N8	ZD602	K6
Q600	C9	ZD603	C3

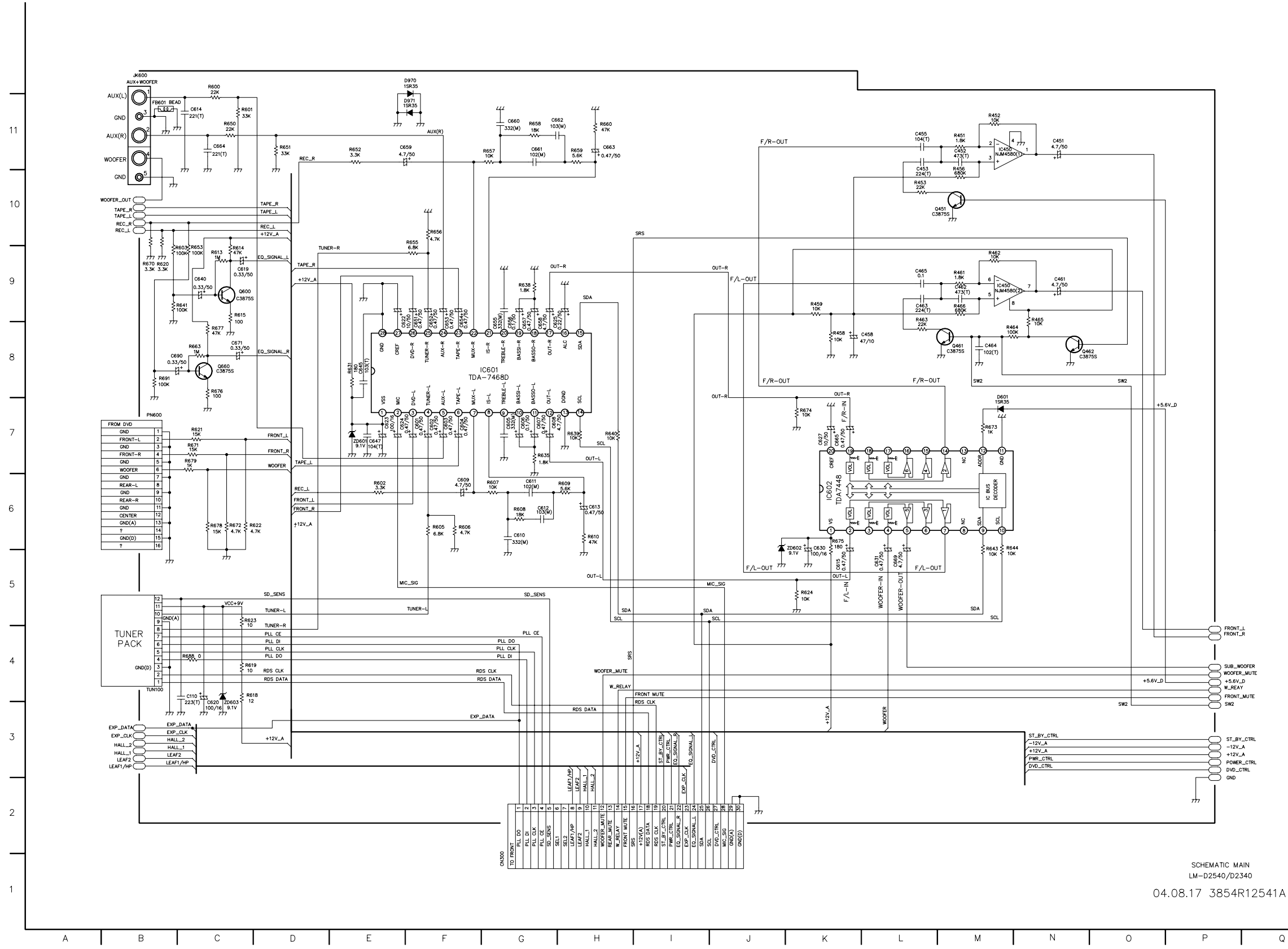

SCHEMATIC MAIN  
LM-D2540/D2340  
04.08.17 3854R12541A

# • MAIN(AMP), SUB POWER SCHEMATIC DIAGRAM

## LOCATION GUIDE

C1700	D7	IC701	F11	R710	M10
C1701	D7	IC707	N3	R711	M10
C1702	E11	IC901	B5	R712	N9
C1703	E9	IC902	C5	R713	O10
C1704	E10	IC903	C4	R714	O10
C1705	L7	IC904	B4	R732	F10
C1707	P9	IC905	C3	R740	P4
C1720	K6	IC906	B3	R741	P4
C1721	K5	IC907	C3	R750	C8
C1722	M6	IC950	I2	R751	C8
C1723	M5	JK700	O10	R752	C8
C1724	N4	JK703	O6	R753	C8
C1732	M5	L701	P5	R754	D8
C1751	H6	OW401	O7	R755	K9
C1770	L2	OW402	N7	R756	J10
C1771	L3	OW403	O7	R757	L9
C1772	M2	OW404	N7	R758	L8
C1773	N2	OW405	O8	R759	L8
C1774	N2	OW406	O8	R760	M9
C1775	O3	OW407	P9	R761	M8
C1776	P3	OW408	P11	R762	N10
C637	H6	OW501	O4	R782	F10
C700	D9	OW502	N10	R783	N8
C701	D9	OW503	N10	R791	B8
C702	K11	PN650	H5	R793	B7
C703	K9	PN901	D5	R922	B2
C704	I9	Q1700	C7	R923	C2
C705	L10	Q1701	H3	R924	B2
C706	N11	Q1702	I3	R931	C4
C707	P10	Q1711	M7	R951	B6
C723	F9	Q1720	L6	R952	B6
C741	P4	Q1721	L5	RW1700	F10
C750	D8	Q1722	M6	RW1702	L8
C751	D8	Q1725	O4	RW700	I1
C752	K11	Q1726	O5	RW702	L10
C753	K9	Q1750	H7	RW703	N10
C754	J10	Q601	H5	RW704	O5
C755	L8	Q700	C9	RW722	G10
C756	N9	Q701	M10	RW750	I11
C757	P9	Q740	O4	RW752	L9
C771	F9	Q741	P4	RW753	N9
C776	N8	Q750	C8	RW754	O6
C778	C9	Q751	M8	RW772	G10
C779	C8	Q791	B8	RW773	N8
C780	F10	Q793	B7	RW785	I10
C781	H10	Q795	O9	R700	P10
C782	G9	Q797	P8	R701	P9
C783	G9	R1700	D7	SW2	K1
C785	I10	R1701	C7	TH601	G6
C786	J10	R1702	C7		
C787	J10	R1703	C7		
C791	B8	R1704	D7		
C793	B7	R1705	E9		
C931	C4	R1706	E10		
C932	C4	R1707	L7		
C933	C3	R1708	L7		
C935	B2	R1709	L7		
C950	I6	R1710	L7		
C951	I7	R1711	M7		
C952	K3	R1712	N8		
C953	I4	R1713	O9		
C954	C10	R1714	O9		
C955	C10	R1715	H3		
C956	I2	R1716	H3		
C957	H2	R1720	K6		
C959	G3	R1721	K5		
C960	F3	R1722	L6		
C961	F3	R1723	L6		
C962	F3	R1724	M5		
C963	C6	R1725	M6		
C964	C6	R1729	N4		
C986	F2	R1731	N5		
C987	F3	R1732	N5		
C988	P5	R1733	N5		
C989	P5	R1734	M5		
C993	E3	R1735	L5		
C995	E3	R1736	M5		
C996	E2	R1750	G6		
CN701	P3	R1751	H7		
CN900	I1	R1753	C7		
CN901	E5	R1754	H6		
CN902	G1	R1756	H9		
CN903	B10	R1770	L2		
D1700	L7	R1771	L3		
D1720	M7	R1772	L3		
D1731	N5	R1773	M2		
D600	H5	R1774	N2		
D650	H5	R1775	N2		
D700	L9	R1776	L4		
D750	L8	R1777	L2		
D780	F11	R1778	N2		
D791	P9	R518	O5		
D793	O8	R637	C5		
D795	O10	R648	C5		
D797	P9	R700	C9		
D904	F5	R701	C9		
D910	F5	R702	C9		
D920	B5	R703	C9		
D921	B5	R704	C9		
FB700	D9	R705	K9		
FB701	J9	R706	I9		
FB750	D8	R707	L10		
FB751	J10	R708	L10		
IC700	J11	R709	L9		

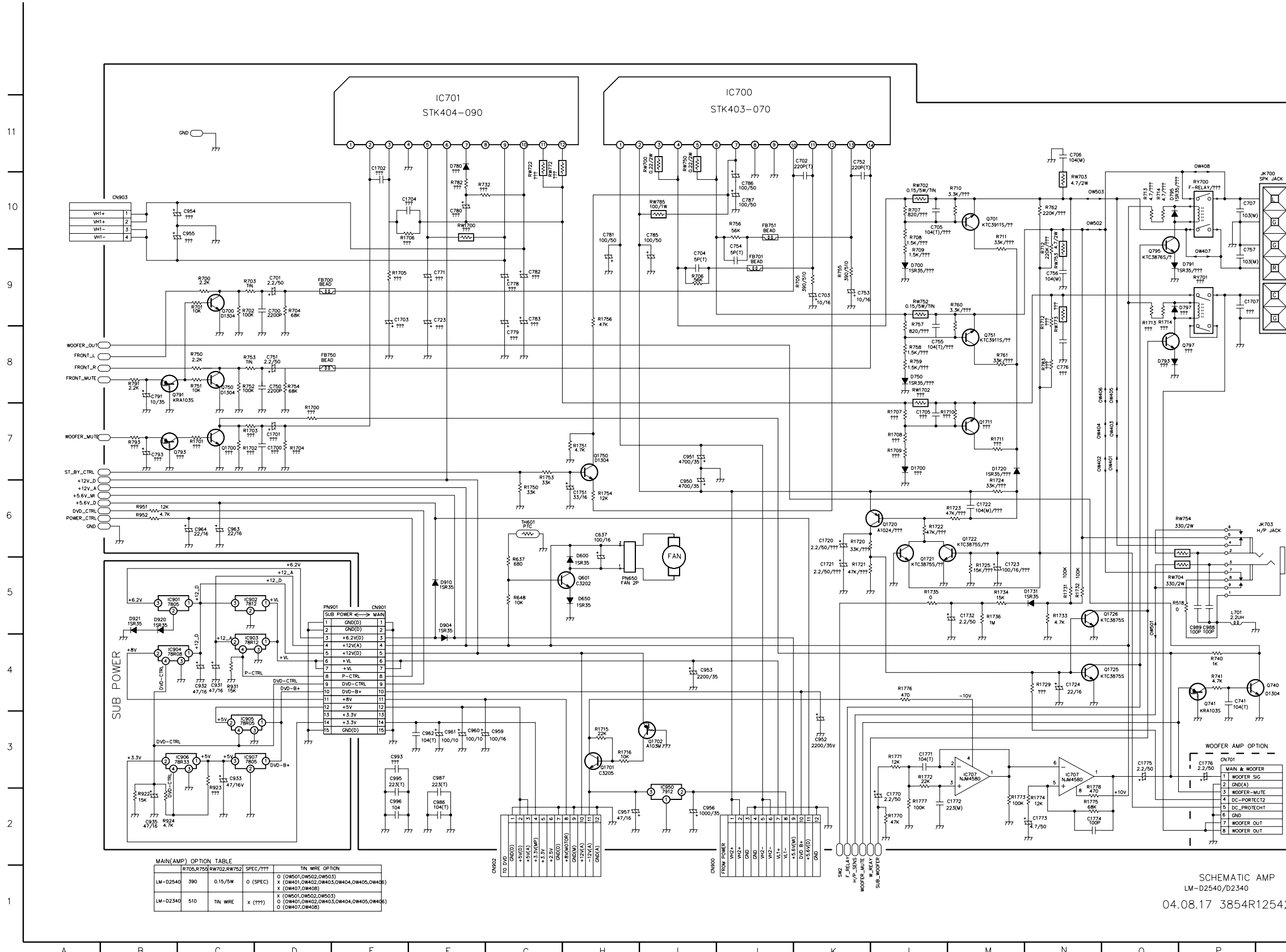

SCHEMATIC AMP  
LM-D2540/D2340  
04.08.17 3854R12542A

# • MAIN(DECK) SCHEMATIC DIAGRAM

## LOCATION GUIDE

C201	C10	R204	D6
C202	G7	R205	F8
C204	F8	R208	H7
C205	F8	R209	H7
C206	G8	R210	I8
C207	D6	R211	H8
C208	F7	R212	L7
C210	H7	R213	K8
C211	H8	R214	K8
C212	H7	R215	K8
C213	H8	R216	M8
C214	L7	R217	N7
C215	LB	R218	M8
C216	LB	R219	N11
C218	M7	R220	N11
C219	N9	R221	M9
C221	LB	R222	M8
C222	LB	R223	M8
C227	F3	R224	N9
C230	G6	R225	M9
C231	G5	R230	F5
C233	D3	R231	G5
C234	D3	R236	C3
C235	E4	R237	F3
C236	E3	R238	F4
C237	F3	R239	G4
C238	F4	R240	O11
C239	C3	R251	C10
C240	I7	R252	E9
C241	O7	R253	F9
C242	O11	R254	C6
C243	M8	R255	F9
C251	C10	R258	H11
C252	F9	R259	H11
C254	F9	R260	I10
C255	F9	R261	I10
C256	G9	R262	L11
C257	C6	R263	J10
C258	F9	R264	K10
C260	H11	R265	K10
C261	H11	R266	M10
C262	H10	R267	M11
C263	H10	R268	M11
C264	L11	R269	N12
C265	L10	R270	N11
C266	L10	R271	M9
C268	M11	R272	M10
C269	N10	R273	M10
C271	L10	R274	N9
C272	L10	R275	M9
C275	J10	R280	I11
C276	I8	R281	K11
C277	J8	R282	J11
C278	L9	R283	I7
C280	N8	R284	I7
C281	M8	R285	I7
C292	O11	R286	J7
C293	M11	R287	L9
C294	G4	R290	O11
C295	I7	R291	F6
C531	K4	R292	F5
C551	H5	R293	F5
C991	B4	R294	F5
C992	B5	R295	F4
C997	B4	R501	M5
C998	B4	R502	M4
D201	O11	R503	M4
D501	K5	R504	M5
D531	L3	R505	L5
D532	L2	R506	L5
D551	H5	R507	L4
FB201	D10	R508	L5
FB202	F7	R509	L4
FB251	D11	R510	K5
FB252	F10	R511	K4
IC201	D5	R512	K5
IC202	G9	R513	K4
IC501	H4	R514	L5
L203	E4	R515	L4
PN201	B11	R516	J5
PN202	B8	R517	L5
PN301	N4	R531	K3
Q201	N7	R532	J3
Q202	M8	R533	K3
Q203	M8	R534	K3
Q206	D3	R535	L2
Q207	F4	R536	L3
Q208	G4	R537	L3
Q251	N10	R538	L3
Q252	M10	R550	H3
Q253	M9	R551	H3
Q254	L11	R552	I5
Q531	K3	R553	I3
Q532	K3	R554	H3
Q533	L3	R555	I5
Q534	L3	R556	I5
Q535	L2	R557	I3
R201	C10	R558	H5
R202	F7	R560	H5
R203	F8	R562	L3
		VR501	L3

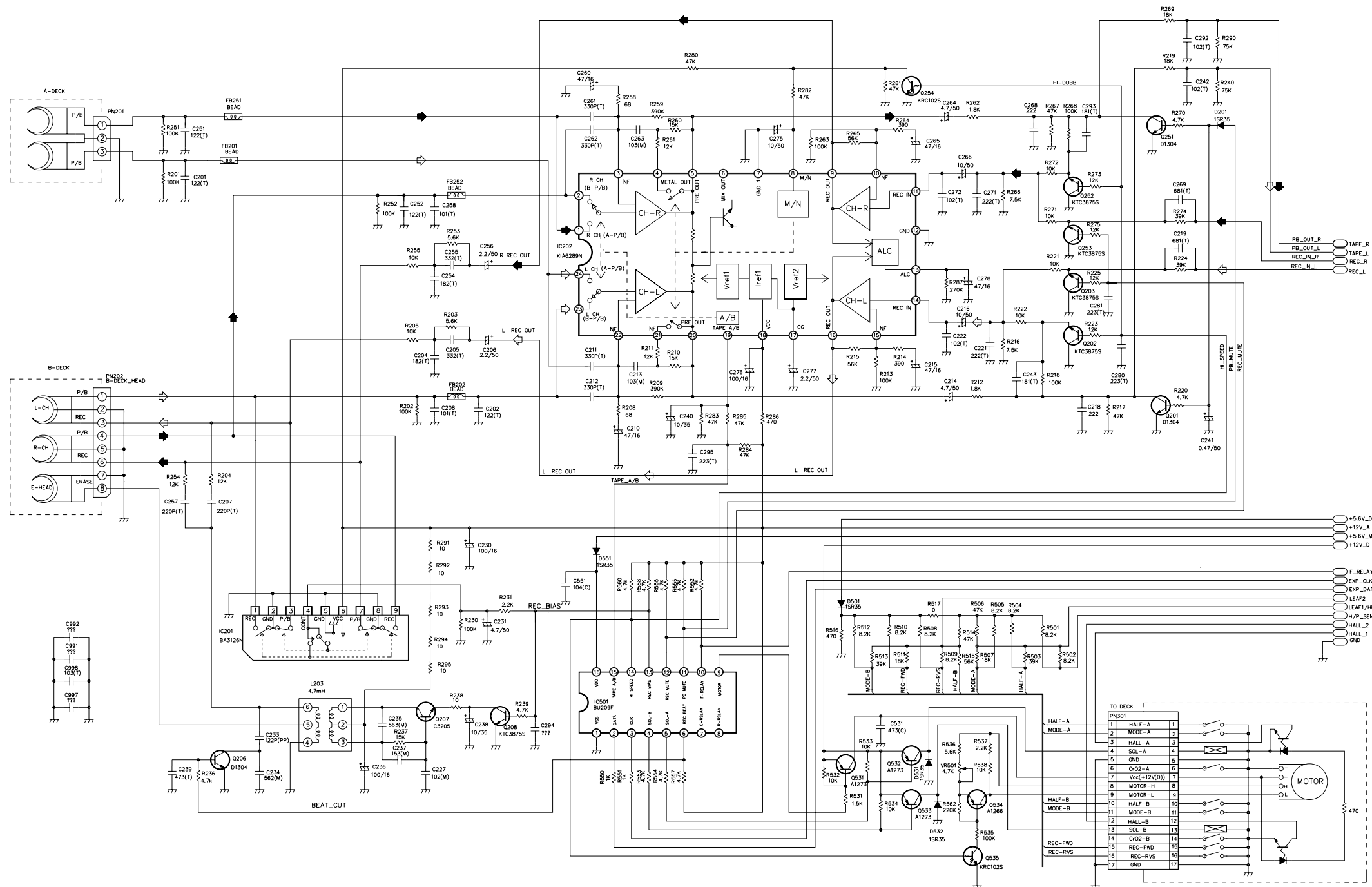

SYMBOL	AUTO-STOP	SINGLE AUTO-REVERSE	DOUBLE AUTO-REVERSE
C233	182(PP)	122(PP)	122(PP)
C234	682(M)	562(M)	562(M)
R204	47K	12K	12K
R254	47K	12K	12K

D.SCHEMATIC DECK  
LM-D2540/D2340  
04.08.17 3854R12543A

# FRONT SCHEMATIC DIAGRAM

FRONT DIODE OPTION TABLE

NO	Symbol	CONTENTS	DESCRIPTION
63	D301	COLON	BLANKING X NON BLANKING
62	D302	RDS	X NON RDS
61	D303	AM STEP	X 9KHZ
60	D304	FM STEP	X 100KHZ
59	D305	DECK A-REVS	O S/A-RYS X S/A-STOP
58	D306	AREA-3	O EUR-3 O JAPAN O S'AFRICA X EUR-2 O SAC O EUR-1 X U.S.A X KOREA
57	D307	AREA-2	O EUR-3 O JAPAN O S'AFRICA X EUR-2 O SAC O EUR-1 X U.S.A X KOREA
56	D308	AREA-1	O EUR-3 O JAPAN O S'AFRICA X EUR-2 O SAC O EUR-1 X U.S.A X KOREA
55	D309	POWER SAVE	O POWER SAVE X NON POWER SAVE
54	D310	D/A-REVS	O D/A-RYS X NON D/A-RYS
53	D311	VOLUME	O INITIAL MODE X LAST MEMORY
52	D312	TUNER	O 2CHP X 1CHIP
50	D313	KARAOKE	O KARAOKE X NON-KARAOKE
49	D314	CH	O 2CH X 5CH
48	D315	ECHO	O NON-ECHO X ECHO
47	D316	SPEANA	O NON-SPEANA X NON-SPEANA

LOCATION GUIDE

C301	K8	Q301	K7	R357	G5
C302	K8	Q302	L7	R358	N3
C303	K7	Q303	C2	R359	N3
C304	K7	Q304	N2	R360	D3
C305	K7	Q305	M2	R361	F2
C306	K7	Q306	M10	R362	F2
C307	K7	Q307	D2	R363	G2
C308	L7	Q602	D10	R364	F2
C309	L7	Q662	D9	R365	F2
C310	L7	R1301	A6	R366	G2
C311	K9	R1303	B5	R367	G2
C312	K9	R1305	C6	R368	G2
C313	J7	R1308	D5	R369	G2
C314	J10	R1309	M3	R371	M6
C315	K8	R1310	M3	R372	M5
C320	N10	R1311	O7	R373	M5
C321	M11	R1321	E6	R374	M5
C323	M10	R1322	E6	R375	M5
C324	M8	R1323	F6	R376	M5
C325	N8	R1337	H2	R377	N5
C326	M8	R1338	H2	R378	N6
C327	O9	R1339	I2	R379	N5
C328	P9	R1340	I2	R380	N5
C329	L12	R1341	I2	R381	N5
C330	N10	R1342	I2	R382	N5
C334	E7	R1343	J2	R383	P3
C345	J9	R1344	J2	R384	P3
C346	B5	R1345	J2	R385	P3
C347	B5	R1346	K2	R386	P3
C348	D9	R1347	M10	R387	P2
C349	D8	R1348	M10	R388	P2
CN302	P12	R1349	M11	R389	O3
CN305	E8	R1350	M11	R390	O3
D302	E8	R1351	G5	R391	O3
D303	E8	R1352	N2	R392	O3
D304	E8	R1354	M5	R393	O3
D305	E8	R1355	L11	R394	O2
D306	E8	R1356	L11	R395	O4
D307	E8	R1357	L10	R396	H2
D308	E8	R1358	O7	R397	H8
D309	E9	R1359	O8	R398	H8
D310	E9	R1397	G5	R399	O2
D311	E9	R1398	G5	R611	C10
D312	E9	R301	J7	R612	C10
D313	E9	R302	J7	R616	C10
D314	E9	R303	J7	R617	D9
D315	E10	R304	L7	R661	C9
D316	E10	R305	K9	R662	C9
D318	E8	R306	K9	R664	C8
D319	L8	R307	L9	R665	D8
D320	L10	R308	L9	RM301	J9
D321	L5	R309	L8	SW301	N6
D323	C8	R310	K8	SW302	N6
D324	K11	R311	F8	SW303	N5
D325	N9	R312	F9	SW304	N5
D602	C10	R313	F8	SW305	N5
D652	C8	R314	F7	SW306	N5
FB301	B10	R316	C8	SW307	N5
IC301	G8	R317	C8	SW308	O6
JOG-A	F7	R318	D8	SW309	O5
JOG-A	P5	R319	D8	SW310	O5
JOG-B	F7	R320	E8	SW311	O5
JOG-B	P5	R321	F5	SW312	O5
KEY_1	O5	R322	O11	SW313	O5
KEY_1	I8	R323	N9	SW314	P3
L301	K8	R324	N10	SW315	P3
LD301	C2	R325	F7	SW316	P3
LD302	N3	R326	B3	SW317	P3
LD303	N4	R327	B3	SW318	P3
LD305	A5	R328	B3	SW319	P2
LD306	A5	R329	B3	SW320	P2
LD307	B6	R330	B3	SW321	O3
LD308	B5	R331	B3	SW322	O3
LD309	C5	R332	B2	SW323	O3
LD310	C5	R333	C3	SW324	O3
LD311	D6	R334	O12	SW325	O3
LD312	D5	R335	M10	SW326	O2
LD313	M3	R336	L11	SW327	O4
LD314	M3	R337	O10	SW328	O2
LD315	M3	R338	N10	SW334	H2
LD316	N3	R339	O9	SW335	H2
LD350	F2	R340	O9	SW336	I2
LD351	F2	R341	O9	SW337	I2
LD352	F2	R342	O9	SW338	I2
LD353	F2	R343	O8	SW339	J2
LD354	G2	R344	O8	SW340	J2
LD355	G2	R346	O8	SW341	J2
LD356	G2	R347	O8	SW342	K2
LD357	G2	R348	O8	SW343	K2
LD358	H2	R349	O8	SW344	K2
LD359	H2	R350	O8	VR302	O4
PN303	P10	R351	O8	VR303	O11
PN304	P9	R352	O8	X301	J8
PN305	L3	R354	O7	X302	J7
PN307	A3	R355	O7	ZD301	K11
PN308	A4	R356	O6	ZD302	K11
				ZD303	L11

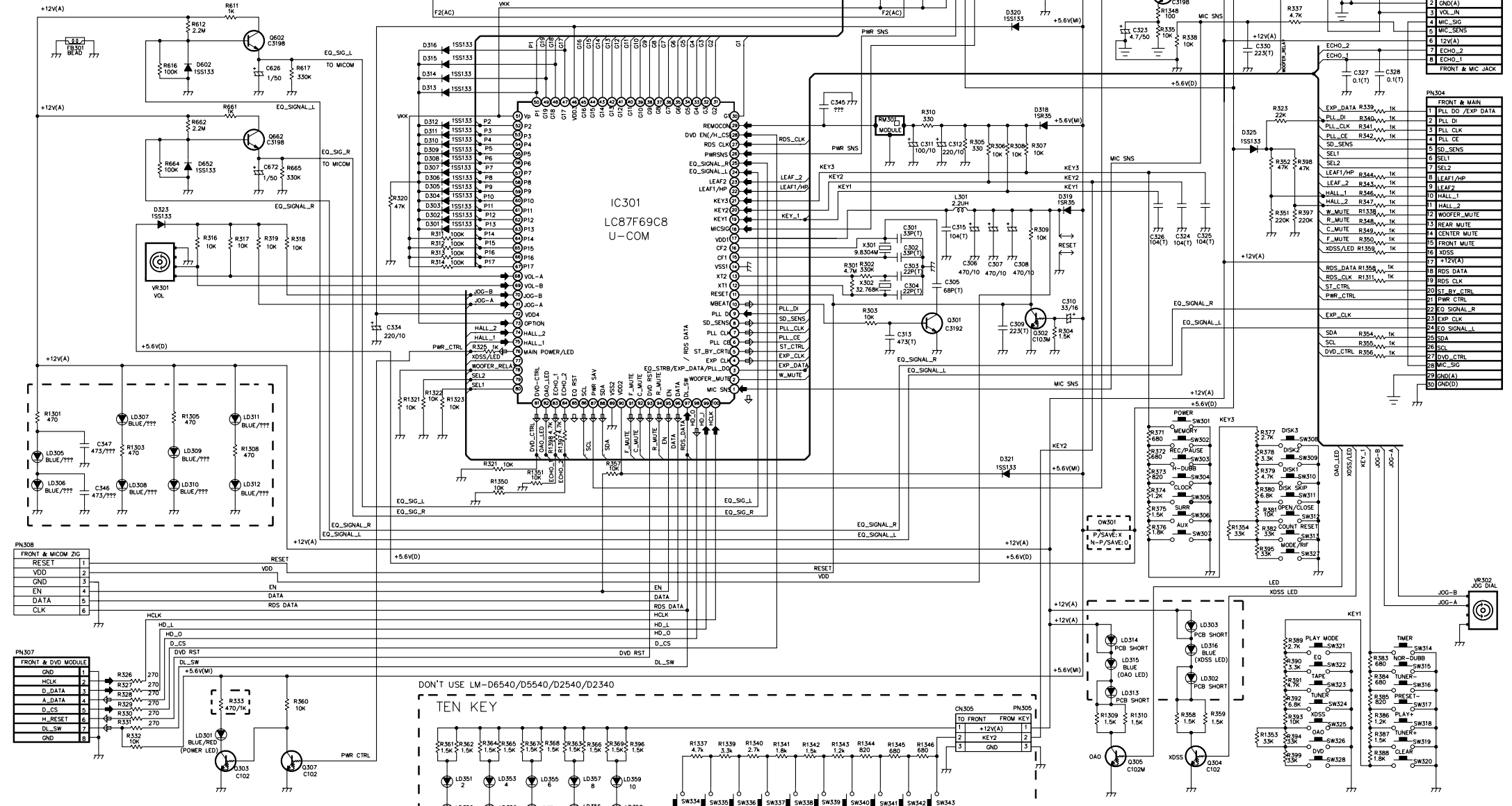

FRONT LED OPTION TABLE

LM-D6540/D5540/D2540	LM-D2340
LD301 O (BLUE)	O (RED)
LD302, LD303, LD305, LD306, LD307 O (BLUE)	X (???)
LD308, LD309, LD310, LD312, LD313, LD314, LD315, LD316, C346, C347 R333 1K	470

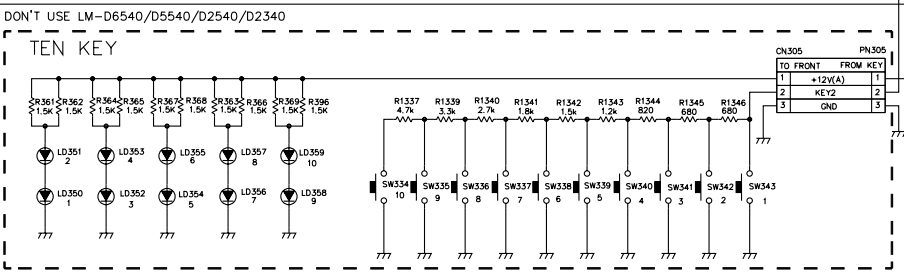

D. SCHEMATIC FRONT  
LM-D6540/D5540/D2540/D2340  
04.08.17 3854R12560A

11  
10  
9  
8  
7  
6  
5  
4  
3  
2  
1

A B C D E F G H I J K L M N O P Q

# • MIC SCHEMATIC DIAGRAM

## LOCATION GUIDE

C400	E10
C401	E9
C402	F7
C403	F8
C404	F10
C405	F10
C406	F10
C407	G10
C409	G8
C410	G8
C411	G8
C412	G10
C413	H8
C414	H10
C415	H7
C416	I10
C417	J10
C418	K8
C419	L9
C420	L9
C421	L10
C423	I4
C427	J4
C428	I4
C429	E4
C430	G5
C431	H5
C433	H4
C435	H4
C436	I5
C443	F2
C444	E2
C450	C6
FB401	D5
IC400	E9
IC401	G6
J401	D6
JK400	C4
JK401	C3
L401	C5
PN400	O9
Q401	F4
Q402	I8
Q403	I8
Q404	J9
Q405	J9
Q406	J9
Q407	L10
Q408	L8
Q412	M8
R400	D10
R401	E10
R402	E10
R403	F10
R404	G10
R405	G10
R406	G10
R407	F8
R408	F8
R409	F8
R410	H7
R411	H9
R412	H10
R413	I10
R414	I9
R415	I9
R416	I9
R417	K10
R418	K8
R419	K9
R420	K8
R421	L8
R422	L9
R423	L9
R424	L10
R426	M3
R427	M5
R428	I4
R429	J4
R430	I5
R431	I5
R432	F4
R433	E4
R434	H5
R435	I5
R436	I5
R437	H4
R439	H4
R440	N5
R441	N4
R442	F4
R443	F2
R444	F2
ZD400	D10

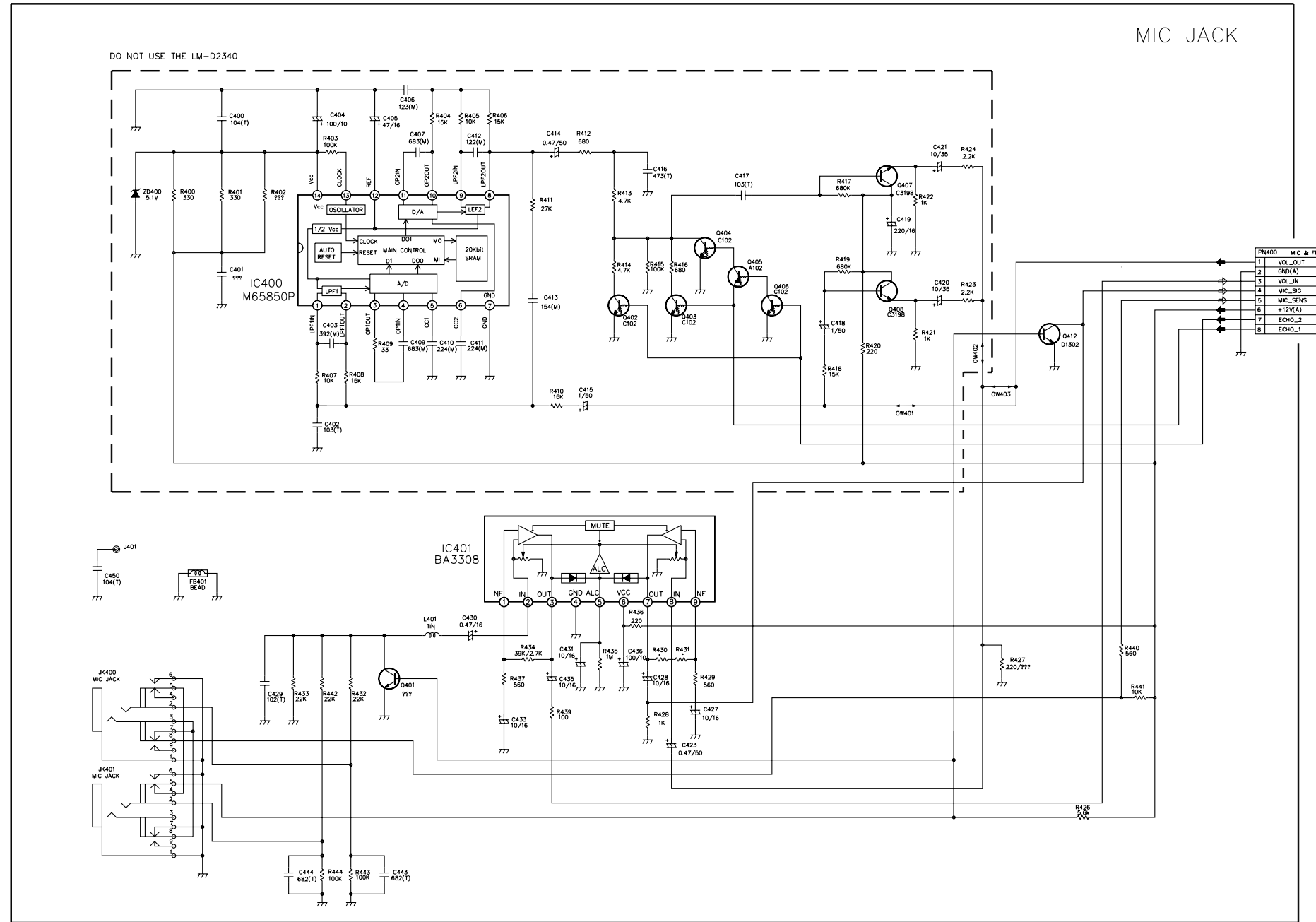

MIC OPTION TABLE (1)

	LM-D6540	D5540	D2540	D2340
R430	680	470	270	T1N
R431	3.9K	3.9K	3.3K	2.7K

MIC OPTION TABLE (2)

	LM-D6540/D5540/D2540	D2340
R434	39K	2.7K
R427	220	x
OW401	o	x
OW402	o	x
OW403	x	o

SCHMATIC MIC  
LM-D6540/D5540/D2540/D2340  
04.08.17 3854R12565A

• POWER, A/V JACK SCHEMATIC DIAGRAM

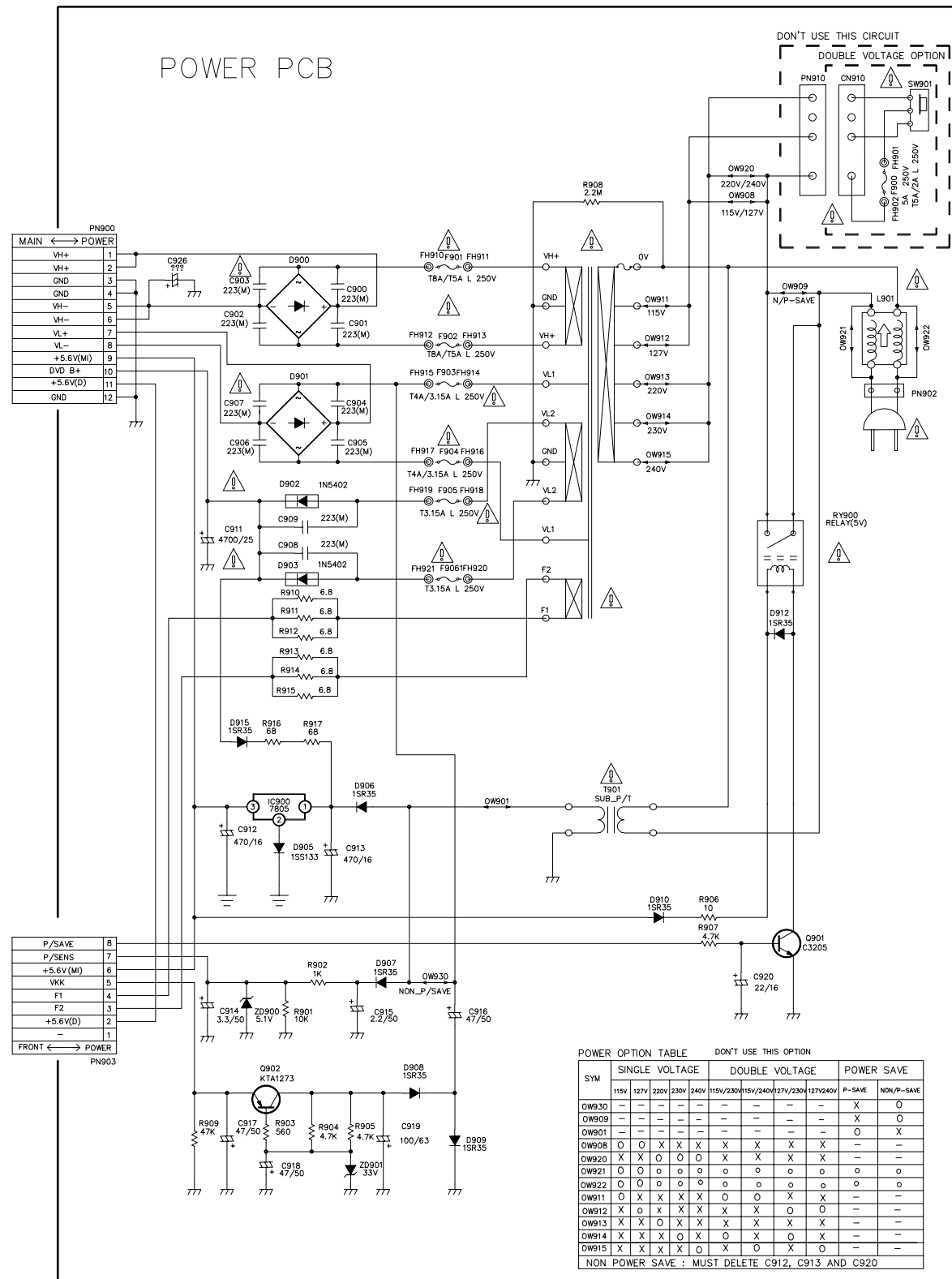

POWER FUSE OPTION TABLE

SYM	LM-D5540	LM-D2540	LM-D2340
F901	T8A L 250V	T5A L 250V	T5A L 250V
F902	T8A L 250V	T5A L 250V	T5A L 250V
F903	T4A L 250V	T4A L 250V	T3.15A L 250V
F904	T4A L 250V	T4A L 250V	T3.15A L 250V
F900	T5A L 250V	T5A L 250V	T2A L 250V

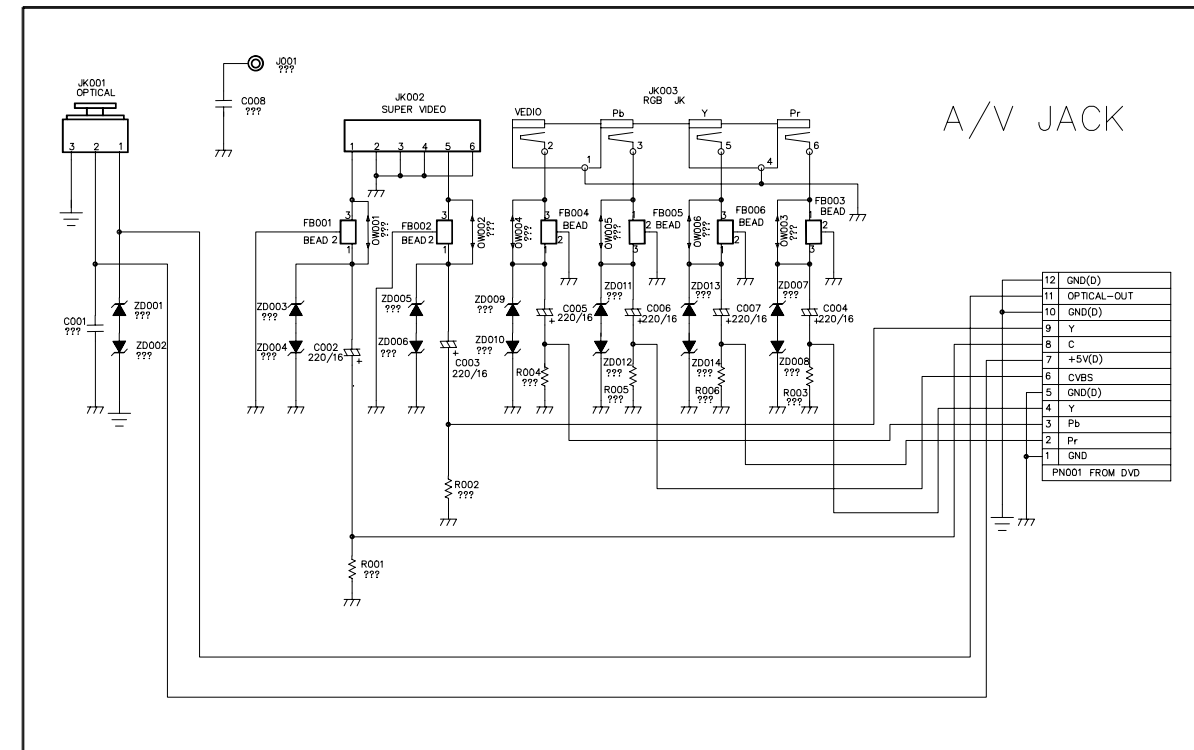

SCHEMATIC POWER/AV JACK  
( LM-D5540/D2540/D2340(S/V)  
VD 3854R12544A

• POWER, A/V JACK SCHEMATIC DIAGRAM

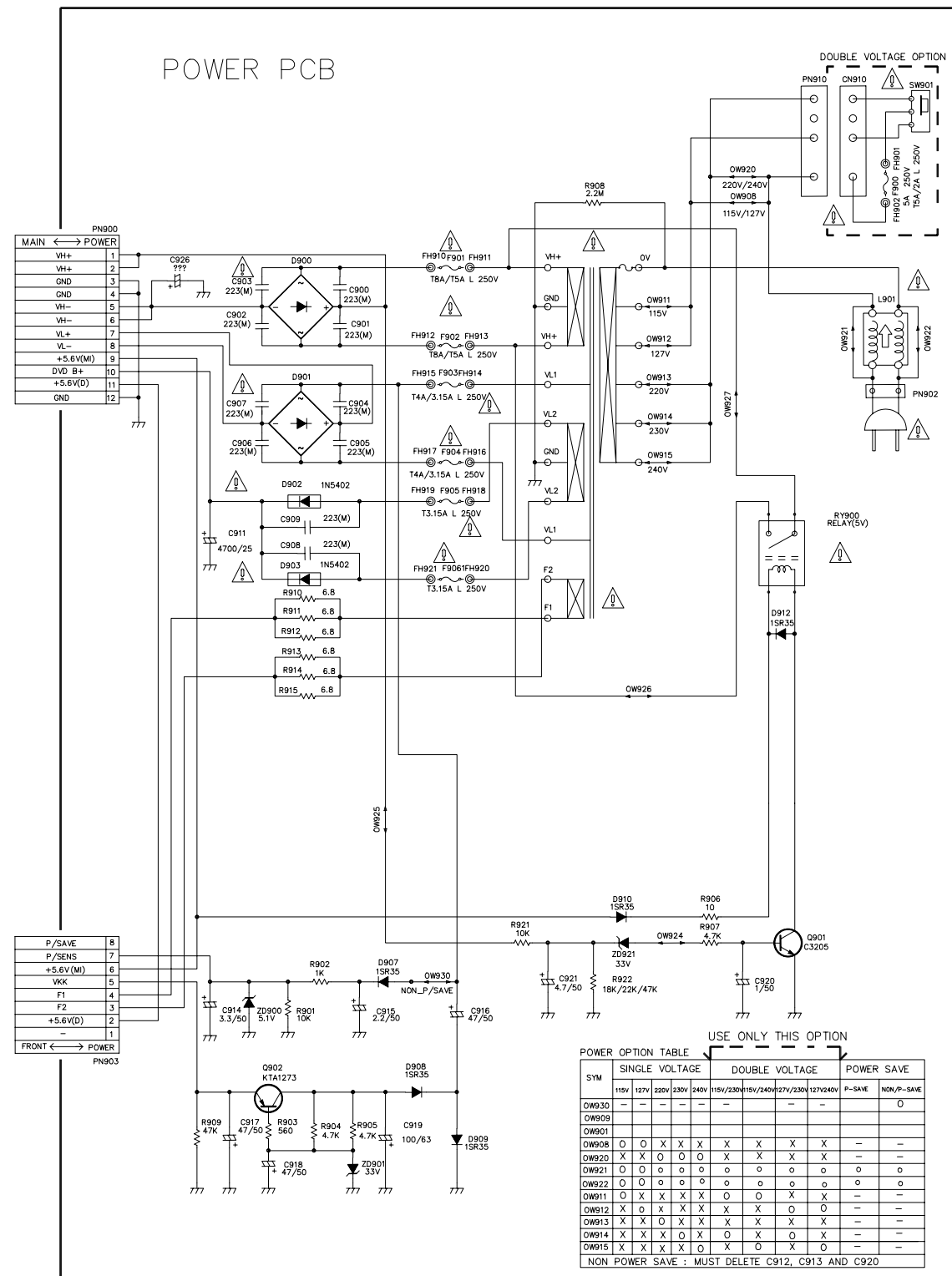

SYM	LM-D5540	LM-D2540	LM-D2340
R922	18K	22K	47K

POWER FUSE OPTION TABLE			
SYM	LM-D5540	LM-D2540	LM-D2340
F901	T8A L 250V	T5A L 250V	T5A L 250V
F902	T8A L 250V	T5A L 250V	T5A L 250V
F903	T4A L 250V	T4A L 250V	T3.15A L 250V
F904	T4A L 250V	T4A L 250V	T3.15A L 250V
F900	T5A L 250V	T5A L 250V	T2A L 250V

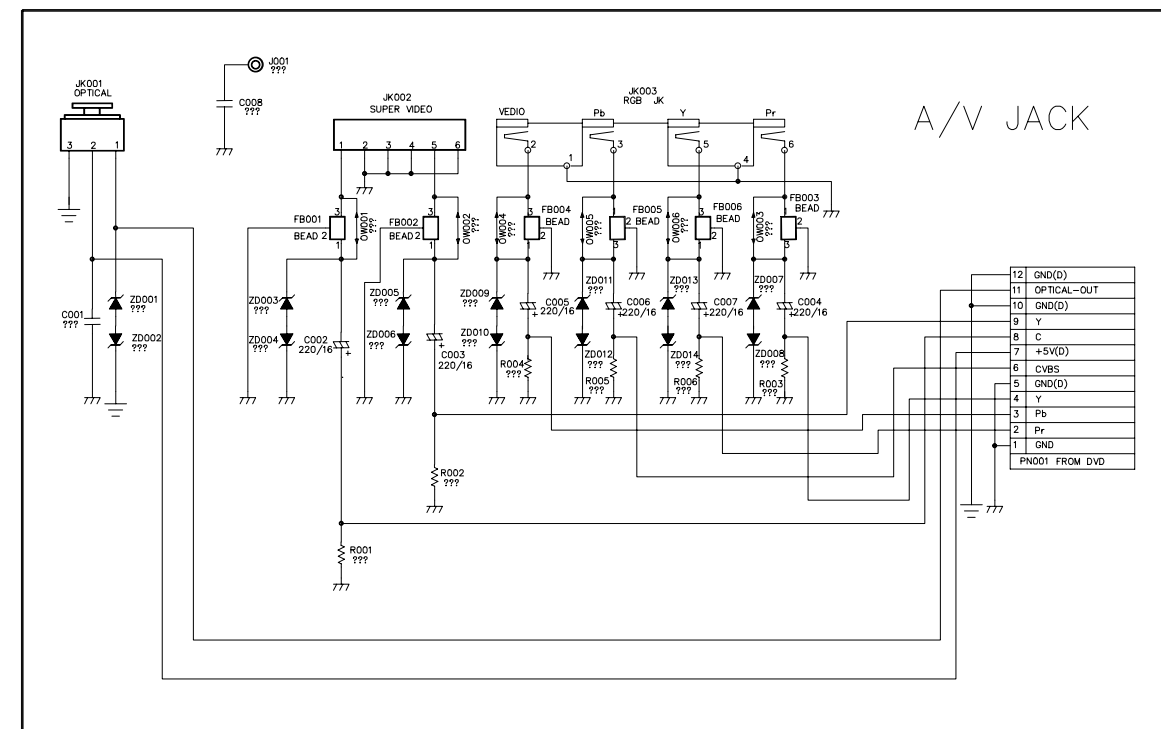

SCHEMATIC POWER/AV JACK  
(LM-D5540/D2540/D2340 (D/V)  
VD 3854R12545A

# WIRING DIAGRAM

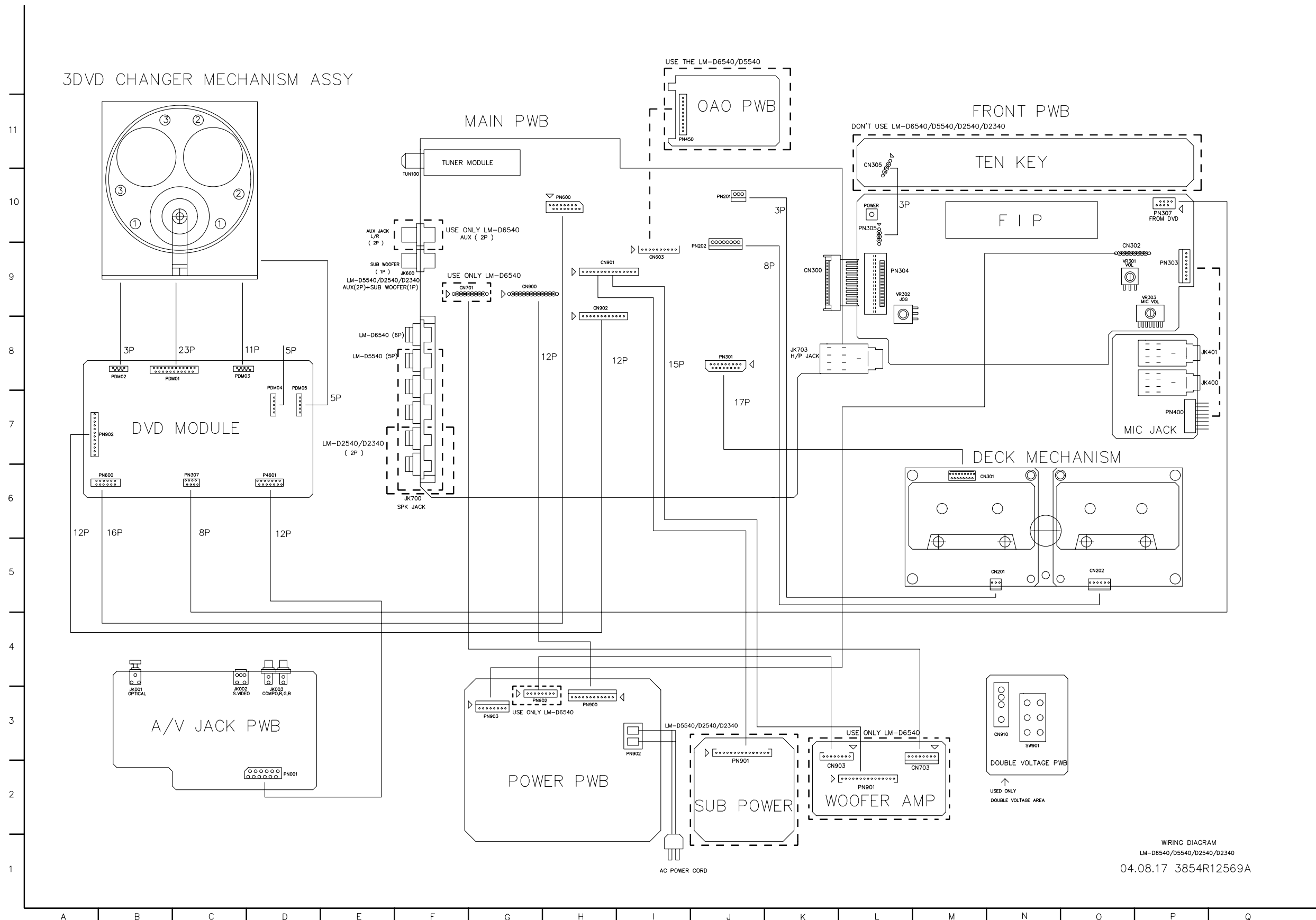

WIRING DIAGRAM  
 LM-D6540/D5540/D2540/D2340  
 04.08.17 3854R12569A



# PRINTED CIRCUIT DIAGRAMS

## MAIN P.C. BOARD (SOLDER SIDE)

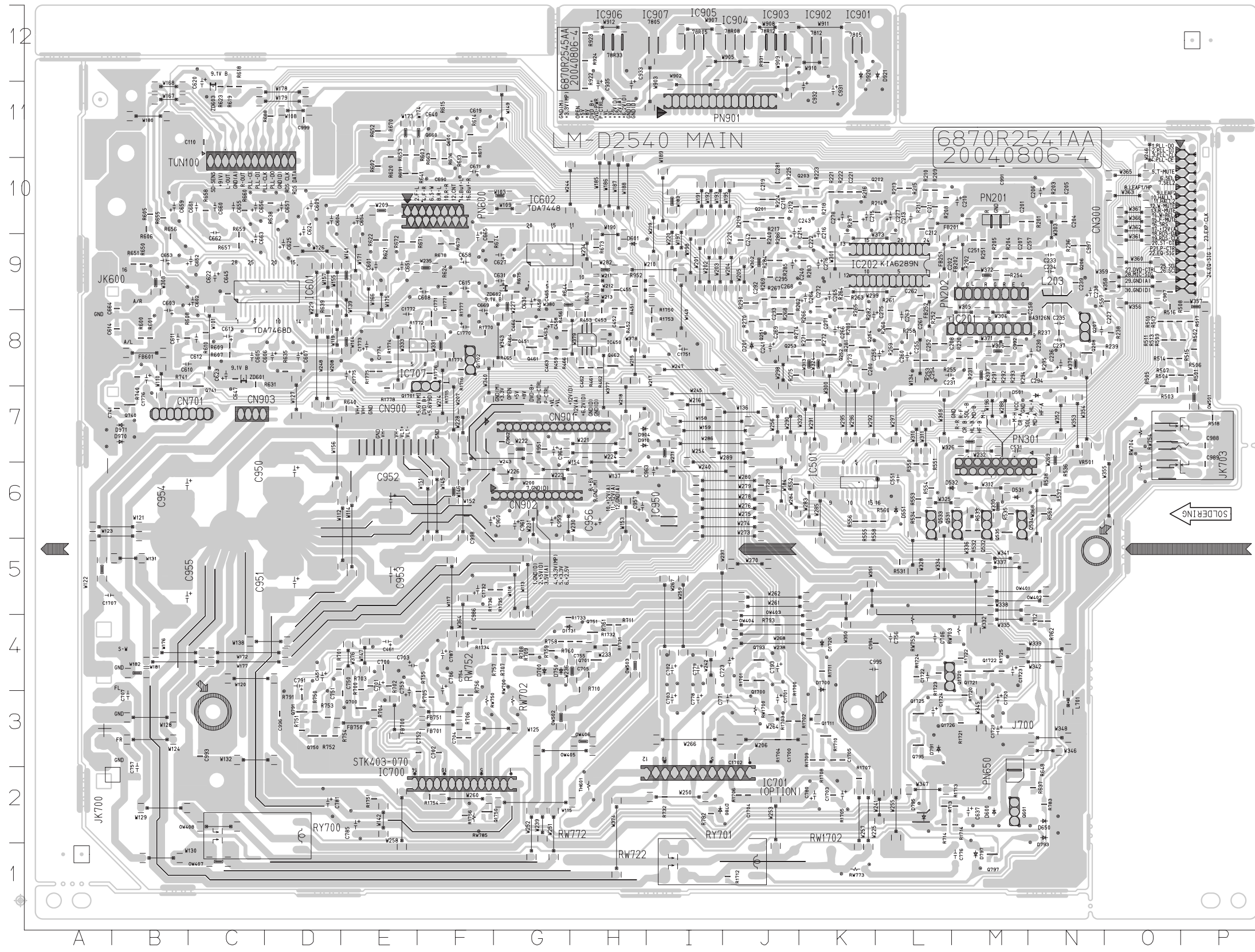

C110	C11	IC501	K6	R1773	F8	R452	H8	R641	E10
C1700	J3	IC601	D9	R1774	E8	R453	H8	R643	H9
C1702	J2	IC602	G9	R1775	E8	R456	G8	R644	H9
C1704	J3	IC707	F8	R1776	F8	R458	G8	R648	N2
C1705	K3	Q1700	J4	R1777	F8	R459	G8	R650	B9
C1771	F8	Q1711	K3	R1778	E7	R461	H8	R651	B9
C1774	E8	Q1721	M4	R201	N10	R462	H8	R652	E11
C201	M10	Q1722	M4	R202	M9	R463	G8	R653	E11
C202	M9	Q1725	L3	R203	N10	R464	G8	R655	B10
C204	N10	Q1726	L3	R204	M9	R465	G8	R656	B9
C205	N10	Q1750	F2	R205	M9	R466	G8	R657	C9
C207	M9	Q201	J10	R208	L10	R501	P8	R658	C10
C208	L8	Q202	L10	R209	L10	R502	P8	R659	C9
C211	L10	Q203	K10	R210	L10	R503	07	R660	C10
C212	L10	Q206	N9	R211	L10	R504	07	R663	F10
C218	J10	Q208	N8	R212	J10	R505	07	R670	E11
C219	J10	Q251	J8	R213	L10	R506	P8	R671	E9
C221	K10	Q252	K8	R214	L10	R507	08	R672	E9
C222	K9	Q253	J8	R215	L10	R508	08	R673	H9
C239	N9	Q254	K8	R216	K10	R509	P8	R674	F9
C242	J9	Q451	G8	R217	J10	R510	08	R675	G9
C243	K10	Q461	G8	R218	K10	R511	08	R676	F10
C251	M9	Q462	H8	R219	J10	R512	08	R677	F11
C252	L8	Q535	M6	R220	J9	R513	08	R678	F9
C254	L8	Q600	F11	R221	K10	R514	08	R679	F9
C255	L8	Q660	F11	R222	K10	R515	08	R688	D11
C257	N9	Q700	E3	R223	K10	R516	09	R691	E10
C258	M8	Q701	H4	R224	J10	R517	P8	R700	E4
C261	L8	Q740	B7	R225	J10	R518	P7	R701	D4
C262	L9	Q741	C7	R230	M8	R531	L5	R702	E4
C268	J9	Q750	D3	R231	M8	R532	M6	R703	E4
C269	J8	Q751	H4	R236	N9	R533	M6	R704	E3
C271	K8	Q791	D3	R237	N8	R534	L6	R705	F3
C272	K9	Q793	J4	R238	08	R535	M6	R706	F3
C280	K8	Q795	L3	R239	N8	R536	N6	R707	G4
C281	J10	Q797	M1	R240	J9	R537	N6	R708	G4
C292	J9	R1700	J3	R251	M9	R538	N6	R709	G4
C293	J8	R1701	J4	R252	L8	R550	L6	R710	H4
C294	N8	R1702	J3	R253	L8	R551	L6	R711	H4
C295	J9	R1703	J3	R254	M9	R552	J6	R712	N4
C452	H9	R1704	J3	R255	L8	R553	L6	R713	L2
C453	H8	R1705	K2	R258	L8	R554	L6	R714	L2
C455	H9	R1706	J2	R259	L8	R555	K6	R732	I2
C462	H8	R1707	K2	R260	L8	R556	K6	R740	B8
C463	G8	R1708	K3	R261	L8	R557	09	R741	B8
C464	G8	R1709	K3	R262	J9	R558	K6	R750	D3
C465	G9	R1710	K3	R263	K9	R560	L6	R751	D3
C614	B8	R1711	K4	R264	K9	R562	N6	R752	D3
C645	C9	R1712	J1	R265	K8	R600	B8	R753	D3
C647	C8	R1713	M2	R266	K8	R601	B8	R754	D3
C664	B9	R1714	M2	R267	J9	R602	E10	R755	F3
C700	E4	R1715	F8	R268	J8	R603	E11	R756	F3
C702	F3	R1716	F8	R269	J9	R605	B10	R757	G4
C704	F3	R1720	M3	R270	J8	R606	B10	R758	G4
C705	H4	R1721	M3	R271	K8	R607	C8	R759	G4
C741	B7	R1722	M4	R272	K8	R608	B8	R760	H4
C750	E3	R1723	L4	R273	K8	R609	C8	R761	H4
C752	F3	R1724	L4	R274	J8	R610	C8	R762	N4
C754	F3	R1725	M4	R275	J8	R613	F11	R782	I2
C755	H4	R1729	J6	R280	K8	R614	F11	R783	N2
C962	G7	R1731	H4	R281	K8	R615	F11	R791	D3
C986	F4	R1732	H4	R282	K8	R618	C11	R793	J4
C987	O9	R1733	G4	R283	K9	R619	C11	R922	H11
C988	P7	R1734	F4	R284	J9	R620	E11	R923	H12
C989	P6	R1735	G5	R285	J9	R621	E9	R924	H12
C991	M10	R1736	F5	R286	J9	R622	E9	R931	J12
C992	M8	R1750	I8	R287	K10	R623	C11	R951	G7
C993	C3	R1751	E2	R290	J9	R624	F9	R952	H9
C994	L4	R1753	I8	R291	M8	R631	C8	ZD601	C8
C996	D3	R1754	F2	R292	M8	R635	D8	ZD602	G9
C997	N9	R1756	F2	R293	M8	R637	N2	ZD603	C11
C998	F6	R1770	F8	R294	M8	R638	D10		
C999	D11	R1771	F8	R295	N8	R639	D8		
IC450	H8	R1772	F8	R451	H9	R640	E7		

• MAIN P.C. BOARD (COMPONENT SIDE)

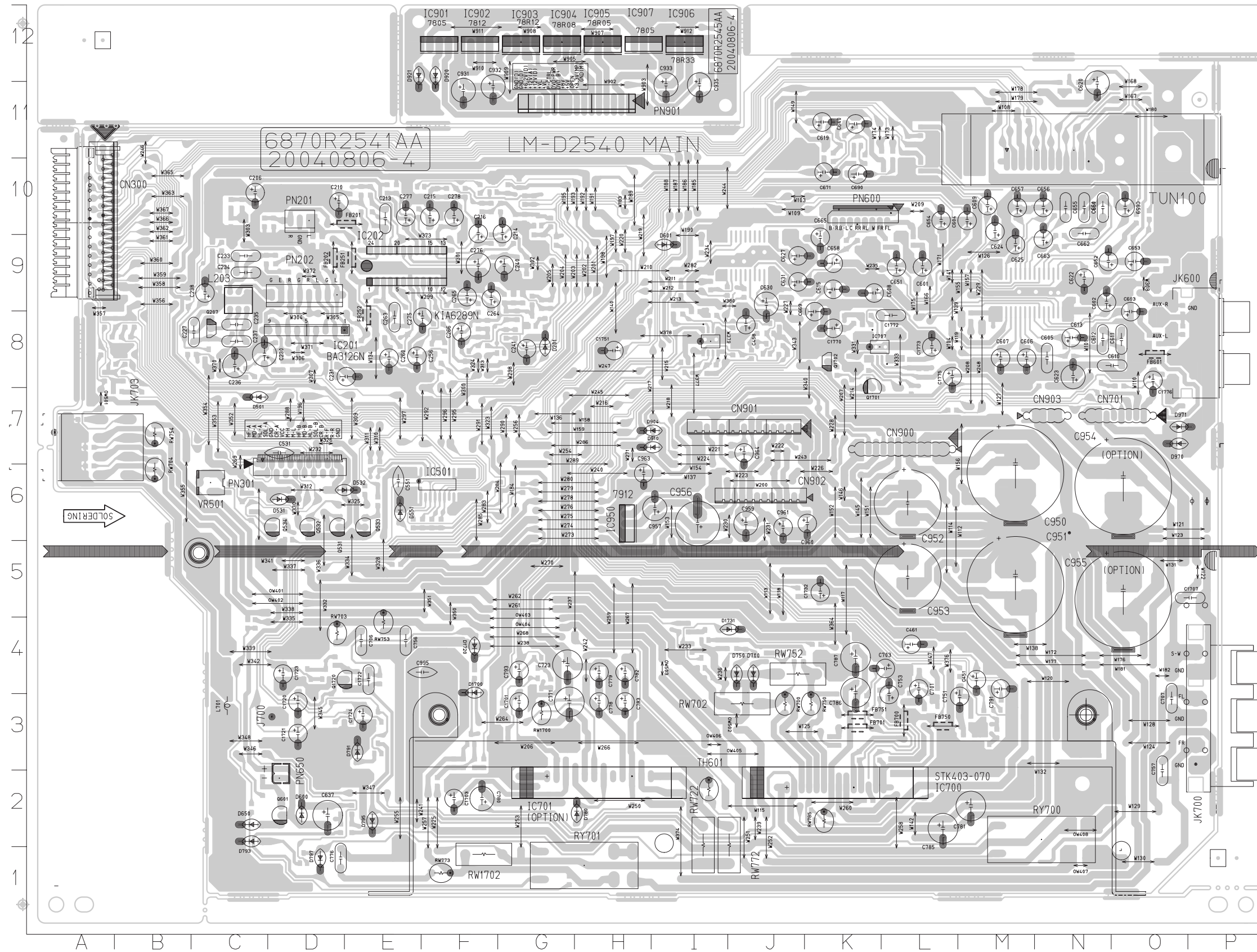

C1701	G3	C660	N10	FB252	E8
C1703	F2	C661	N10	FB601	O8
C1707	P5	C662	N10	FB700	L3
C1720	D3	C663	N9	FB701	K3
C1721	D3	C665	K9	FB750	L3
C1722	E4	C669	K8	FB751	K3
C1723	D4	C671	K10	IC201	E8
C1724	E3	C690	K10	IC202	E9
C1732	K5	C701	L4	IC700	J2
C1751	H8	C703	L4	IC701	G2
C1770	K8	C706	E4	IC901	F12
C1772	L8	C707	O3	IC902	F12
C1773	L8	C723	G4	IC903	G12
C1775	L8	C751	M3	IC904	G12
C1776	O8	C753	L3	IC905	H12
C206	C10	C756	E4	IC906	I12
C210	D10	C757	O2	IC907	H12
C213	E10	C771	G3	IC950	H6
C214	G10	C776	D1	J700	D3
C215	F10	C778	H3	JK600	P9
C216	F10	C779	H4	JK700	P3
C227	C8	C780	F2	JK703	A7
C230	C8	C781	M2	L203	C9
C231	E8	C782	H4	L701	C3
C233	C9	C783	H3	OW401	D5
C234	C9	C785	L2	OW402	D5
C235	C8	C786	K4	OW403	G4
C236	C8	C787	K4	OW404	G4
C237	C8	C791	M4	OW405	J3
C238	C9	C793	G4	OW406	I3
C240	G9	C931	F1	OW407	N1
C241	G8	C932	F1	OW408	N2
C256	E8	C933	I1	OW501	A7
C260	E8	C935	I1	OW502	J3
C263	E8	C950	M6	OW503	I4
C264	F9	C951	M5	PN201	D10
C265	F9	C952	L6	PN202	D9
C266	F8	C953	L5	PN301	C6
C275	F8	C954	O6	PN600	D10
C276	F9	C955	O5	PN650	L2
C277	E10	C956	I6	PN901	G1
C278	F10	C957	I6	Q1701	K7
C451	M4	C959	J6	Q1702	K8
C458	J8	C960	K6	Q1720	E4
C461	L4	C961	J6	Q207	C8
C531	D7	C963	H6	Q531	D6
C551	E6	C964	J7	Q532	D6
C601	L9	C995	F4	Q533	E6
C602	N9	CN300	A10	Q534	D6
C603	O8	CN701	O7	Q601	D2
C604	M10	CN900	L7	RW1700	G3
C605	N8	CN901	J7	RW1702	F1
C606	M8	CN902	J6	RW700	J3
C607	M8	CN903	N7	RW702	J3
C608	K9	D1700	F4	RW703	D4
C609	M10	D1720	F4	RW704	B6
C610	O8	D1731	J4	RW722	I2
C611	O8	D201	G8	RW750	K3
C612	N8	D501	C7	RW752	J4
C613	N8	D531	D6	RW753	E4
C615	K9	D532	E6	RW754	B7
C619	K11	D551	E6	RW772	J2
C620	N11	D600	D2	RW773	F1
C622	N9	D601	I9	RW785	K2
C623	N8	D650	C2	RY700	N2
C624	M10	D700	J4	RY701	H1
C625	M9	D750	J4	TH601	I2
C627	J9	D780	H2	TP1	A1
C630	J9	D791	E3	TP4	A8
C631	J9	D793	C2	TP5	A8
C637	D2	D795	E2	TP2	A1
C640	K11	D797	D1	TP3	B1
C651	L9	D904	I7	TP4	A10
C652	N9	D910	I7	TP5	A10
C653	O9	D920	F12	TP7	A10
C654	L10	D921	E12	TP8	B1
C655	N10	D970	O7	TP9	B8
C656	N10	D971	O7	TUN100	N10
C657	M10	FB201	E10	VR501	C6
C658	K9	FB202	D9		
C659	O10	FB251	E9		

• FRONT P.C. BOARD (SOLDER SIDE)

IC301 3F

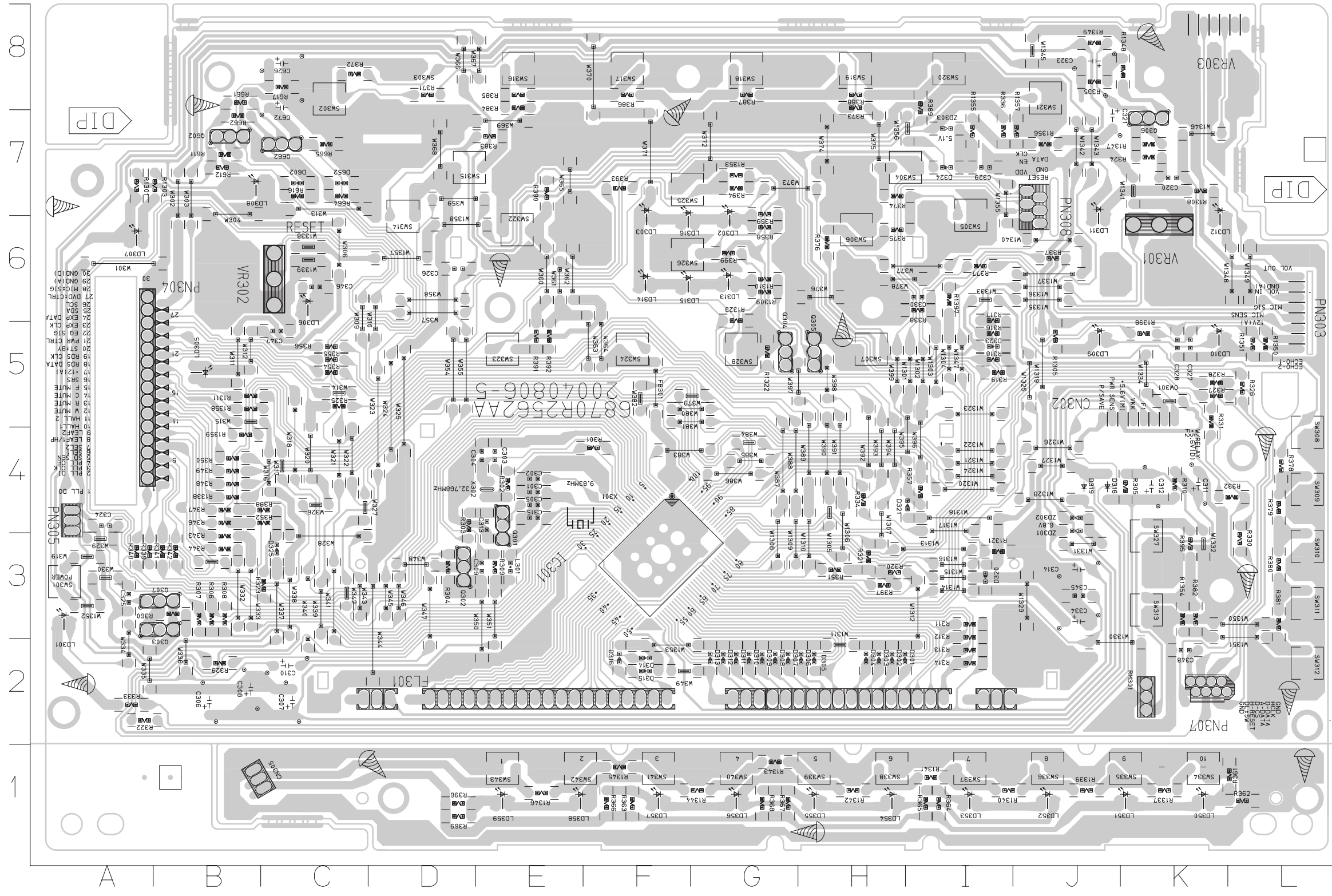

• FRONT P.C. BOARD (COMPONENT SIDE)

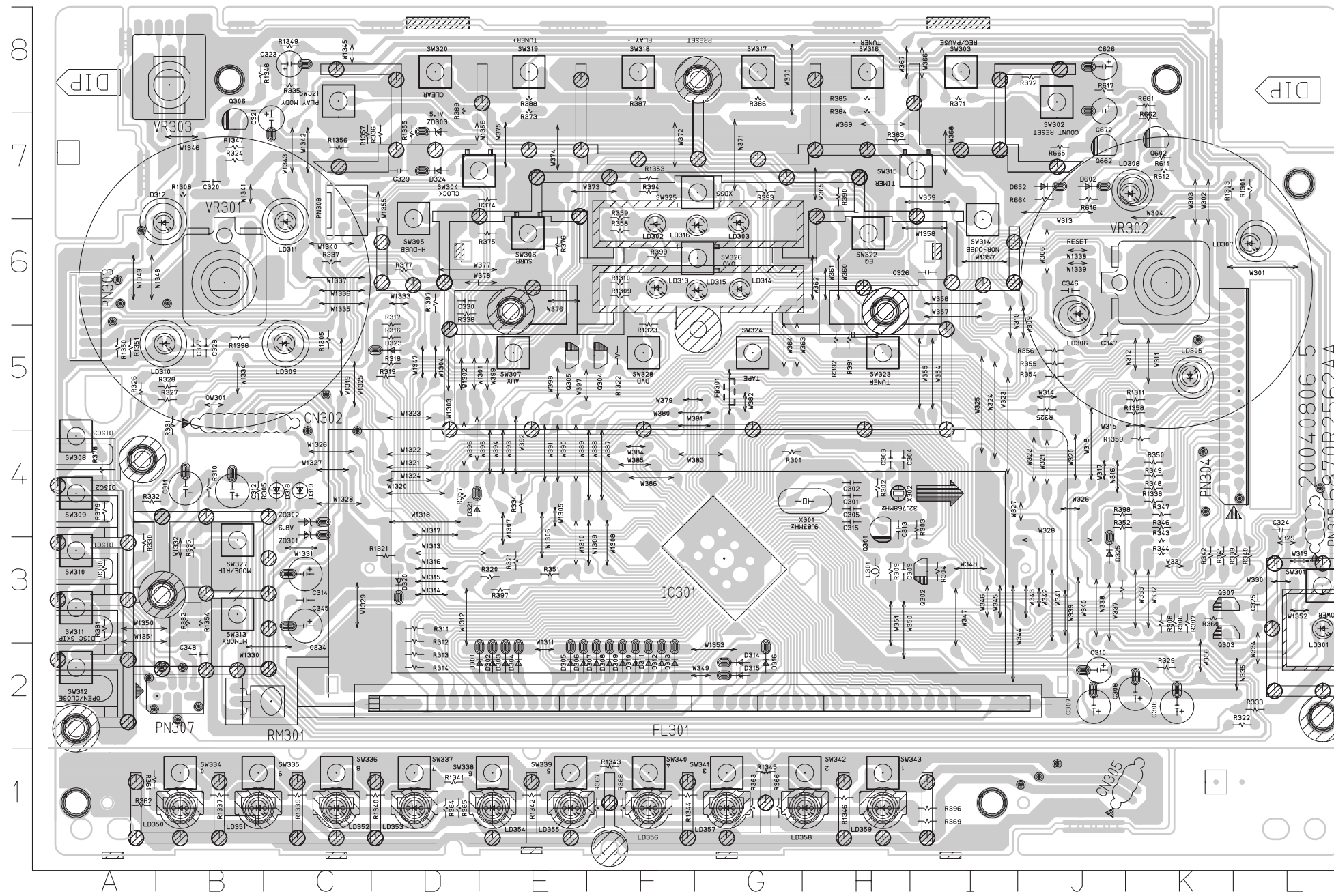

C301	H4	D315	G2	Q304	F5	R309	H3	R360	K3	SW301	L3
C302	H4	D316	G2	Q305	E5	R310	B4	R361	A1	SW302	J8
C303	H4	D318	C4	Q306	B7	R311	D3	R362	A1	SW303	I8
C304	H4	D319	C4	Q307	K3	R312	D3	R363	G1	SW304	E7
C305	H4	D320	D3	Q602	K7	R313	D2	R364	D1	SW305	D6
C306	K2	D321	D4	Q662	J7	R314	D2	R365	D1	SW306	E6
C307	J2	D323	D5	R1301	L7	R316	D5	R366	G1	SW307	E5
C308	K2	D324	D7	R1303	K7	R317	D6	R367	F1	SW308	A4
C309	H3	D325	J3	R1305	C5	R318	D5	R368	F1	SW309	A4
C310	J2	D602	J7	R1308	B7	R319	D5	R369	I1	SW310	A3
C311	B4	D652	J7	R1309	F6	R320	E3	R371	I8	SW311	A3
C312	B4	FB301	G5	R1310	F6	R321	E3	R372	J8	SW312	A2
C313	H4	FL301	F2	R1311	K5	R322	L2	R373	E8	SW313	B3
C314	C3	L301	H3	R1321	D3	R323	J3	R374	E7	SW314	I6
C315	H4	LD301	L3	R1322	F5	R324	B7	R375	E6	SW315	I7
C320	B7	LD302	F6	R1323	F6	R325	J5	R376	E6	SW316	H8
C321	C7	LD303	G6	R1327	B1	R326	A5	R377	D6	SW317	G8
C323	C8	LD305	K5	R1338	K4	R327	B5	R378	A4	SW318	F8
C324	L4	LD306	J6	R1339	C1	R328	B5	R379	A4	SW319	E8
C325	L3	LD307	L6	R1340	D1	R329	K2	R380	A3	SW320	D8
C326	I6	LD308	K7	R1341	D1	R330	A3	R381	A3	SW321	C8
C327	B5	LD309	C5	R1342	E1	R331	B5	R382	B3	SW322	H6
C328	B5	LD310	B5	R1343	F1	R332	A4	R383	H7	SW323	H5
C329	D7	LD311	C6	R1344	F1	R333	L2	R384	H8	SW324	G5
C330	D6	LD312	B6	R1345	G1	R334	E4	R385	H8	SW325	G7
C334	C3	LD313	F6	R1346	H1	R335	C8	R386	G8	SW326	G6
C345	C3	LD314	G6	R1347	B7	R336	D7	R387	F8	SW327	B3
C346	J6	LD315	G6	R1348	B8	R337	C6	R388	E8	SW328	F5
C347	J5	LD316	G6	R1349	C8	R338	D6	R389	D8	SW334	B1
C348	B2	LD350	B1	R1350	A5	R339	L3	R390	H7	SW335	B1
C626	J8	LD351	B1	R1351	A5	R340	L3	R391	H5	SW336	C1
C672	J8	LD352	C1	R1353	F7	R341	K3	R392	H5	SW337	D1
CN302	B5	LD353	D1	R1354	B3	R342	K3	R393	G7	SW338	E1
CN305	J1	LD354	E1	R1355	D7	R343	K3	R394	F7	SW339	E1
D301	E2	LD355	E1	R1356	C7	R344	K3	R395	B3	SW340	F1
D302	E2	LD356	F1	R1357	C7	R346	K4	R396	I1	SW341	G1
D303	E2	LD357	G1	R1358	K5	R347	K4	R397	E3	SW342	H1
D304	E2	LD358	H1	R1359	K4	R348	K4	R398	J4	SW343	H1
D305	E2	LD359	H1	R1397	D6	R349	K4	R399	F6	VR301	B6
D306	E2	OW301	B5	R1398	B5	R350	K4	R611	K7	VR302	K6
D307	F2	PN303	A5	R301	G4	R351	E3	R612	K7	VR303	B8
D308	F2	PN304	L5	R302	H4	R352	J4	R616	J7	X301	H4
D309	F2	PN305	L4	R303	I4	R354	J5	R617	J8	X302	H4
D310	F2	PN307	B2	R304	I3	R355	J5	R661	K8	ZD301	C4
D311	F2	PN308	C7	R305	B4	R356	J5	R662	K7	ZD302	C4
D312	F2	Q301	H4	R306	K3	R357	D4	R664	J7	ZD303	D7
D313	F2	Q302	I3	R307	K3	R358	F6	R665	J7		
D314	G2	Q303	K3	R308	K3	R359	F7	RM301	C2		

• POWER P.C. BOARD (COMPONENT SIDE)

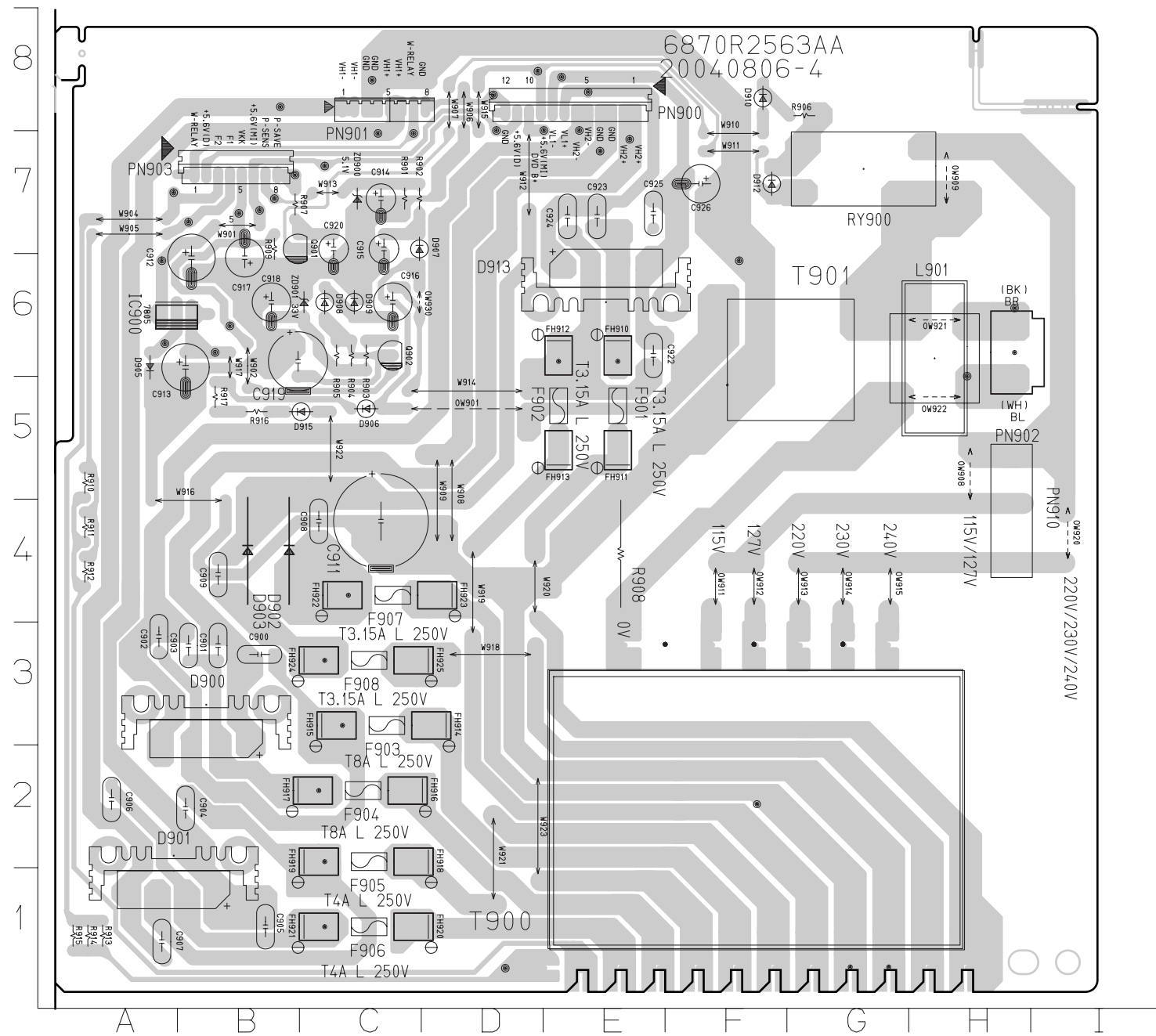

• POWER P.C. BOARD (SOLDER SIDE)

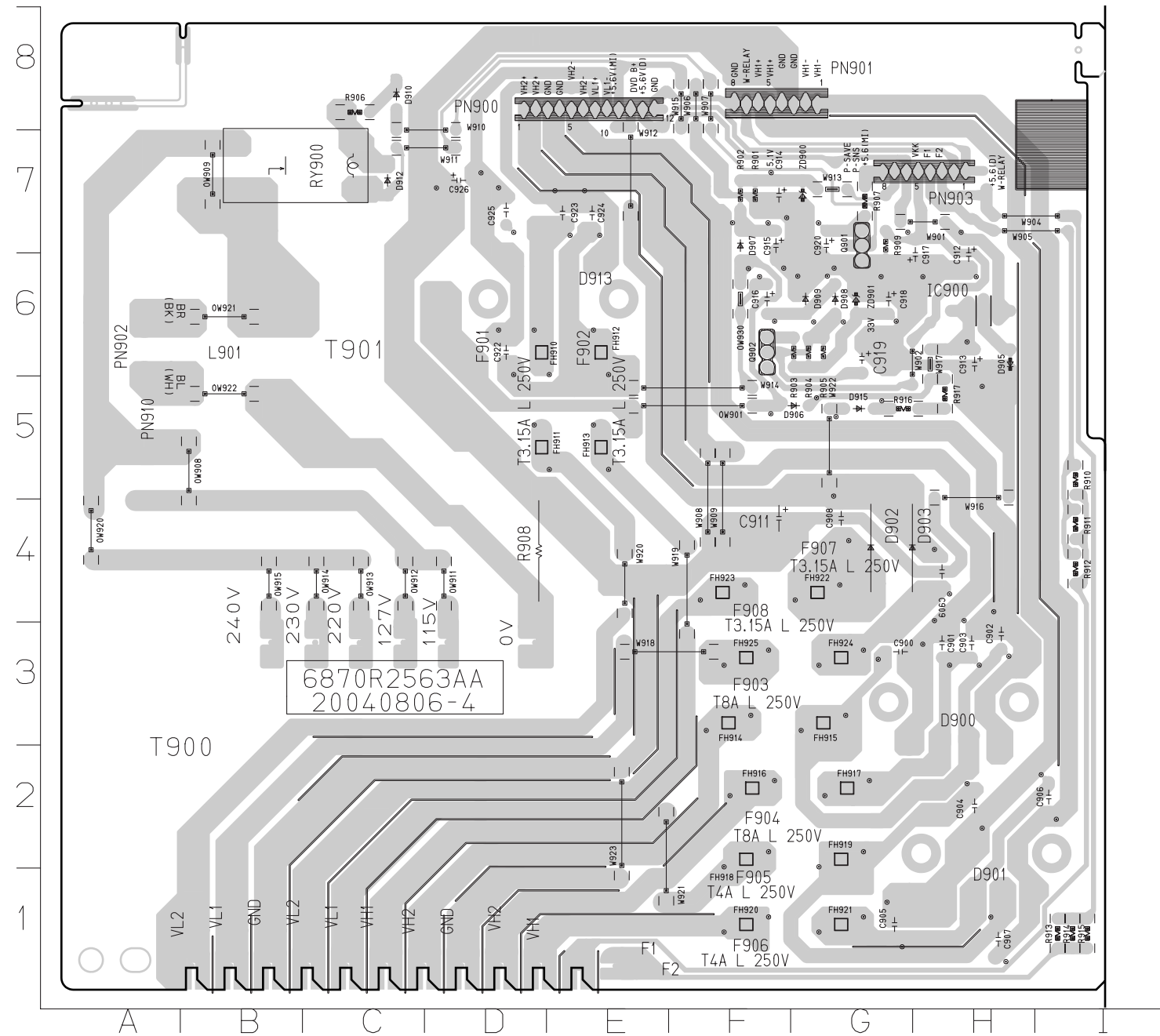

• POWER P.C. BOARD (SOLDER SIDE)

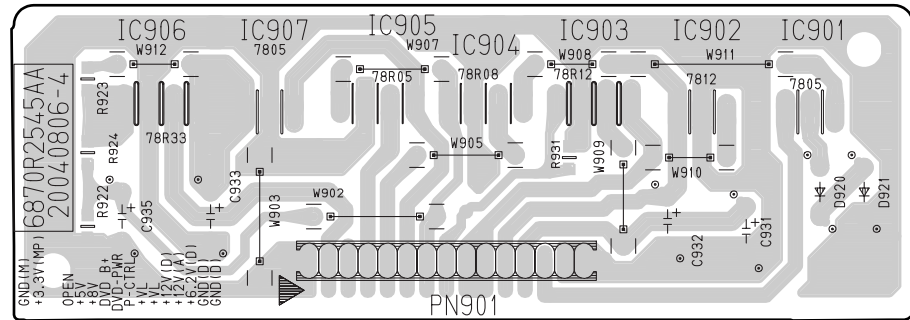

• POWER P.C. BOARD (COMPONENT SIDE)

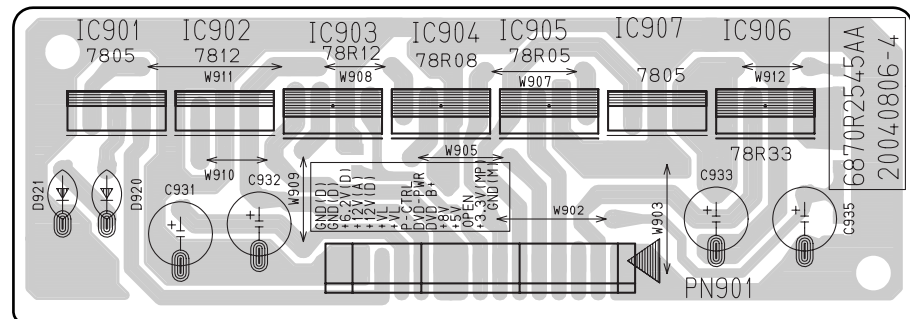

• FAN ZIG P.C. BOARD

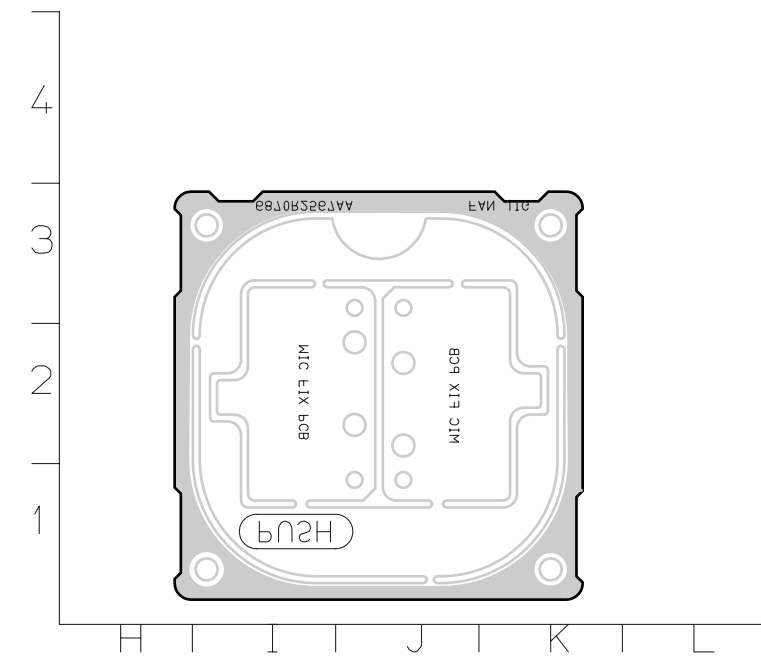

• DOUBLE VOLTAGE P.C. BOARD

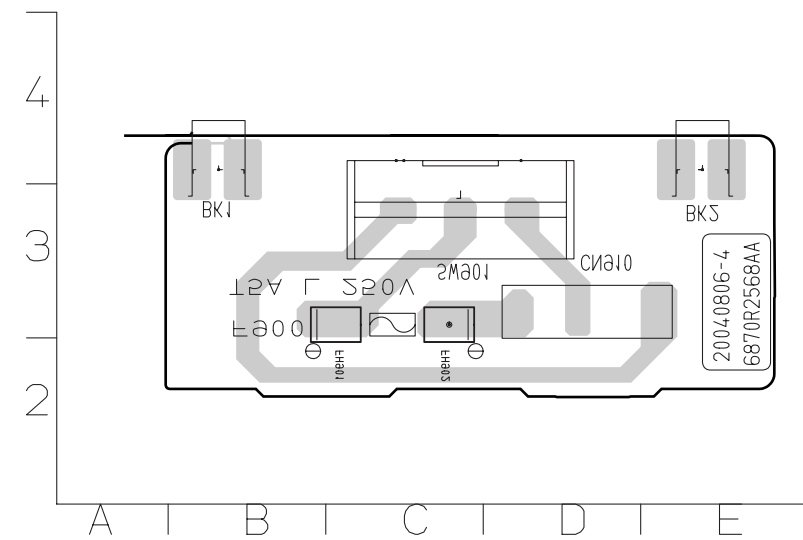

• A/V JACK P.C. BOARD (SOLDER SIDE)

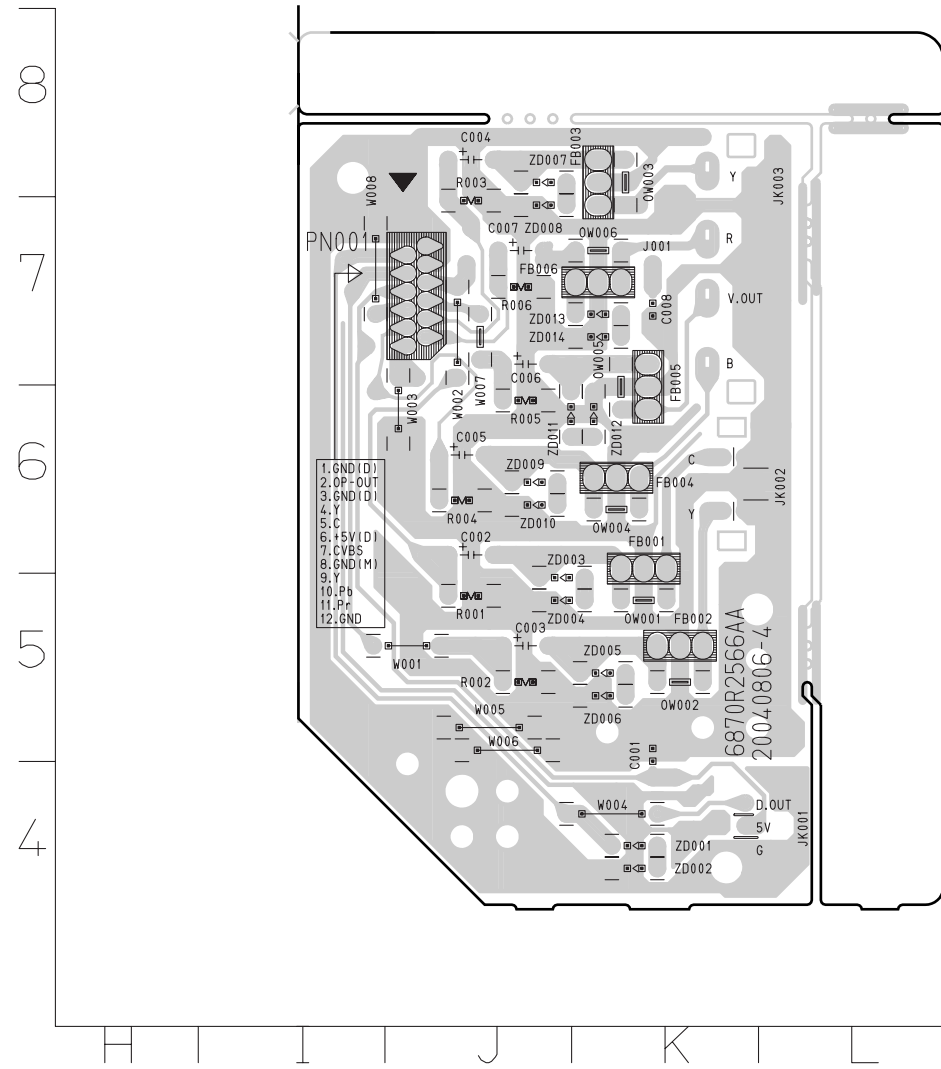

• A/V JACK P.C. BOARD (COMPONENT SIDE)

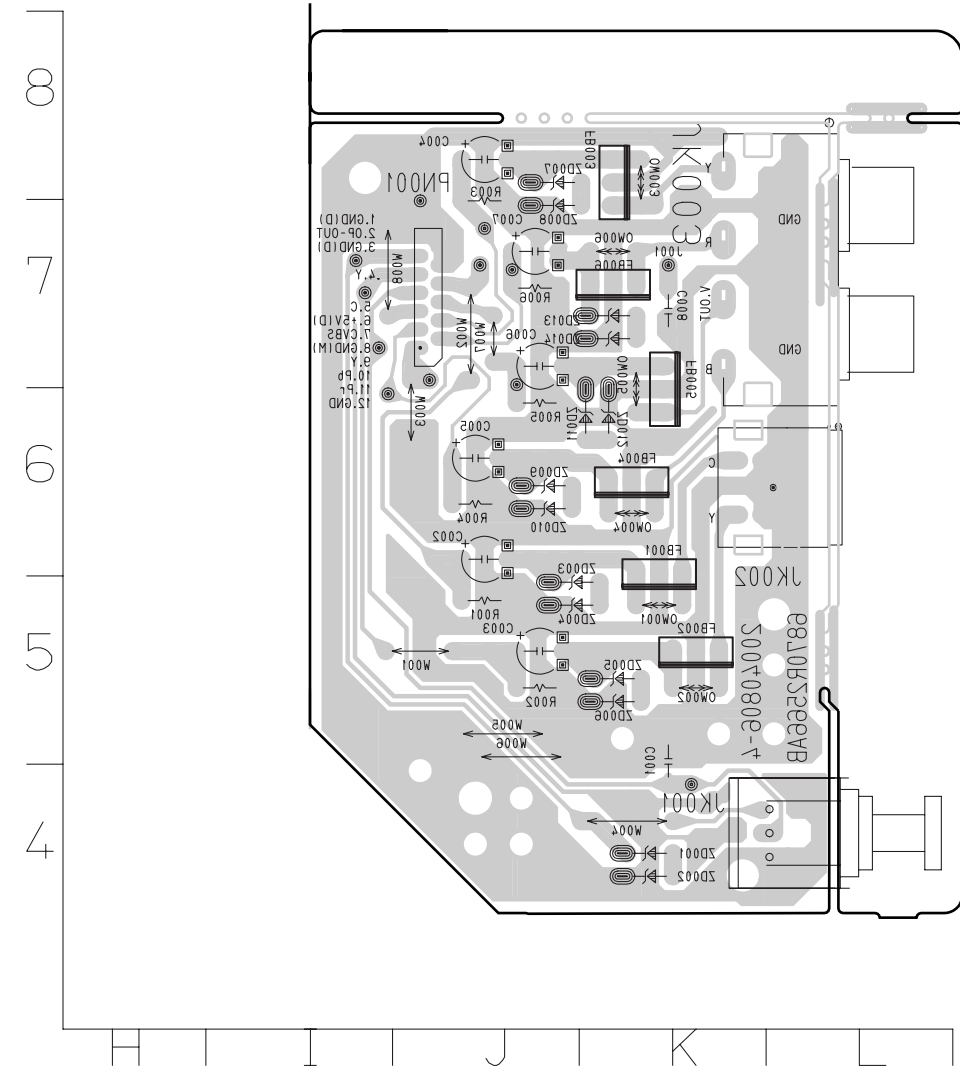



**MEMO**

Horizontal dotted lines for writing.

**MEMO**

Horizontal dotted lines for writing.

# SECTION 3. DVD PART

## □ DVD ELECTRICAL TROUBLESHOOTING GUIDE

### 1. Power check flow

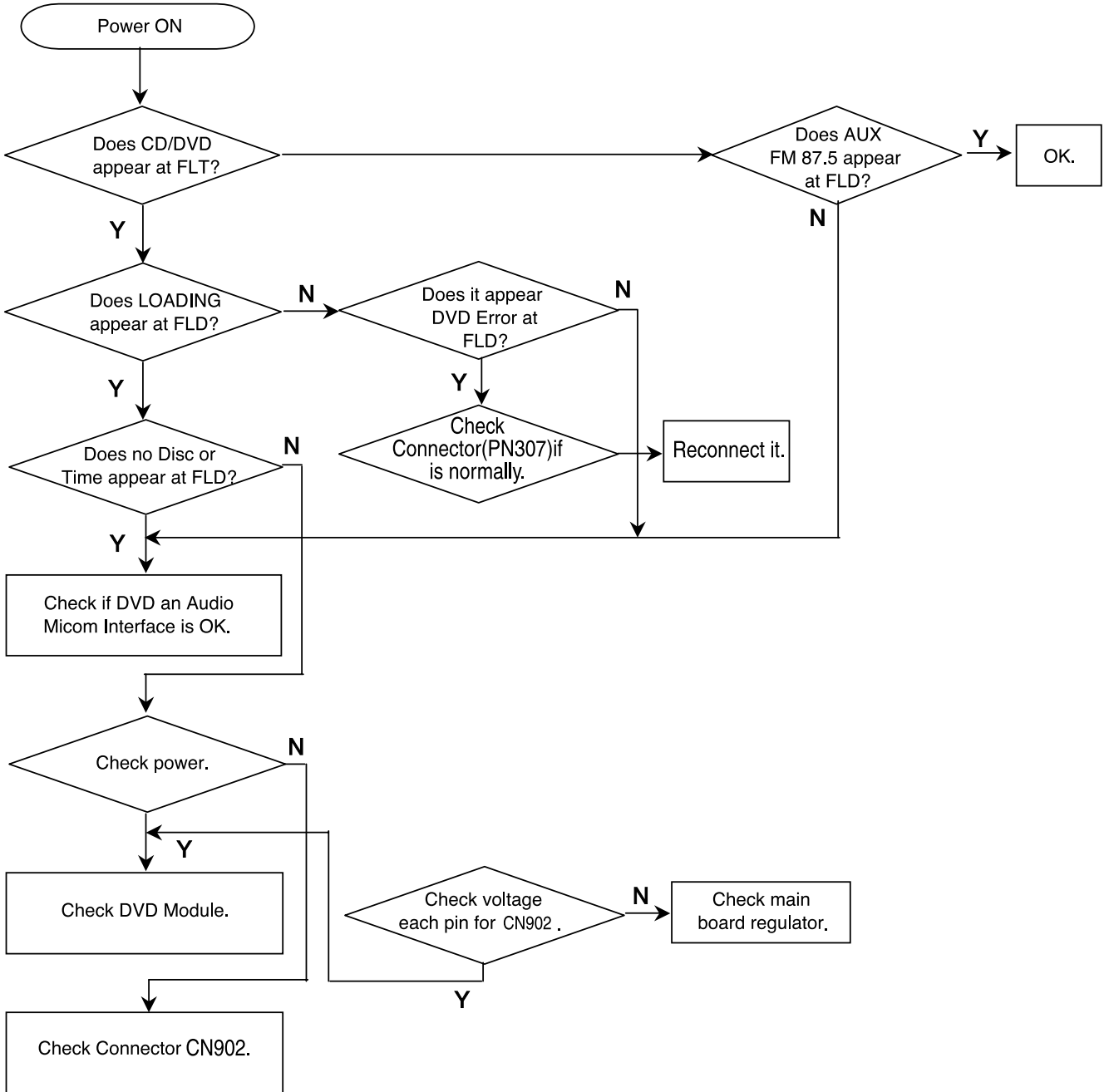

## 2. Test & debug flow

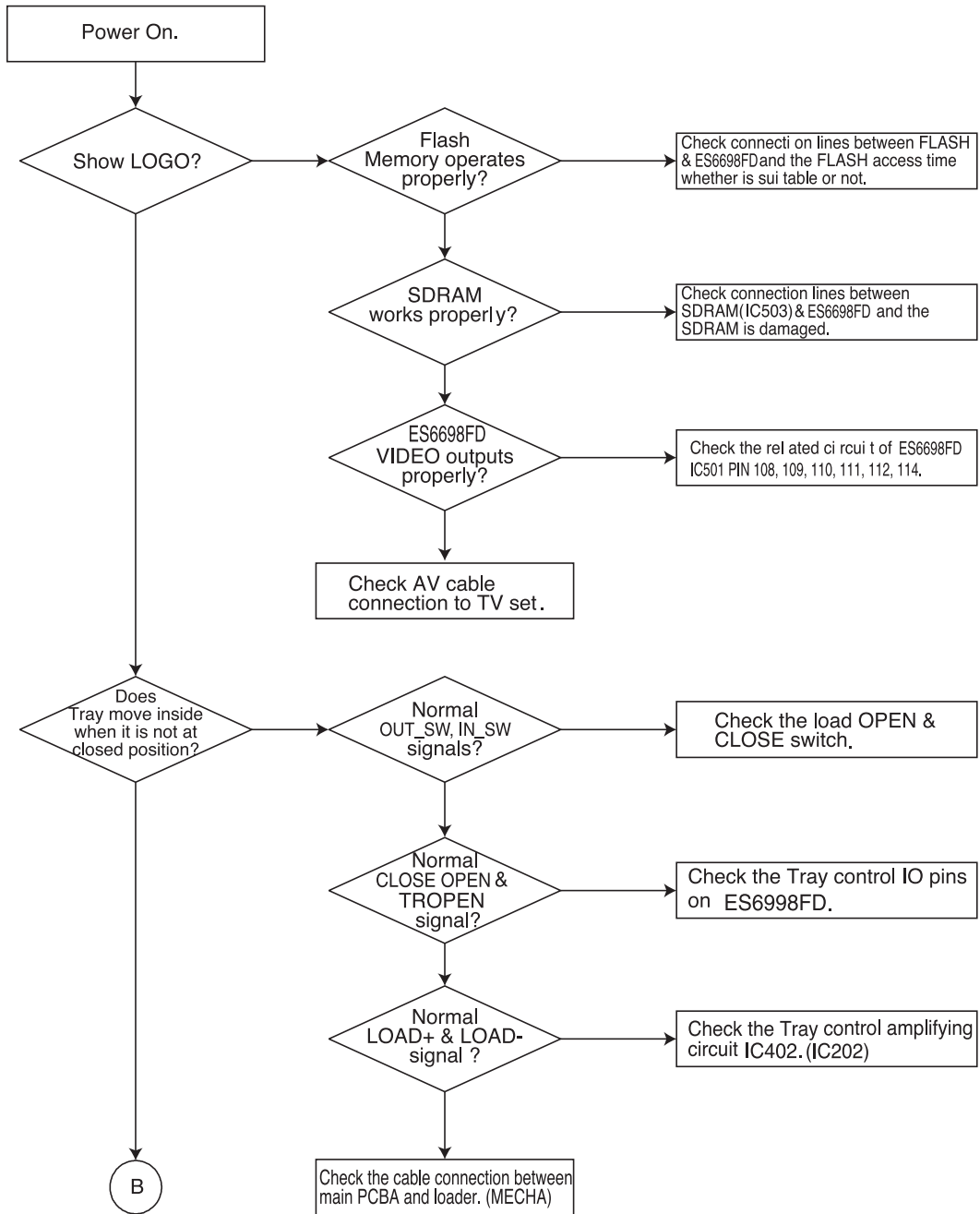

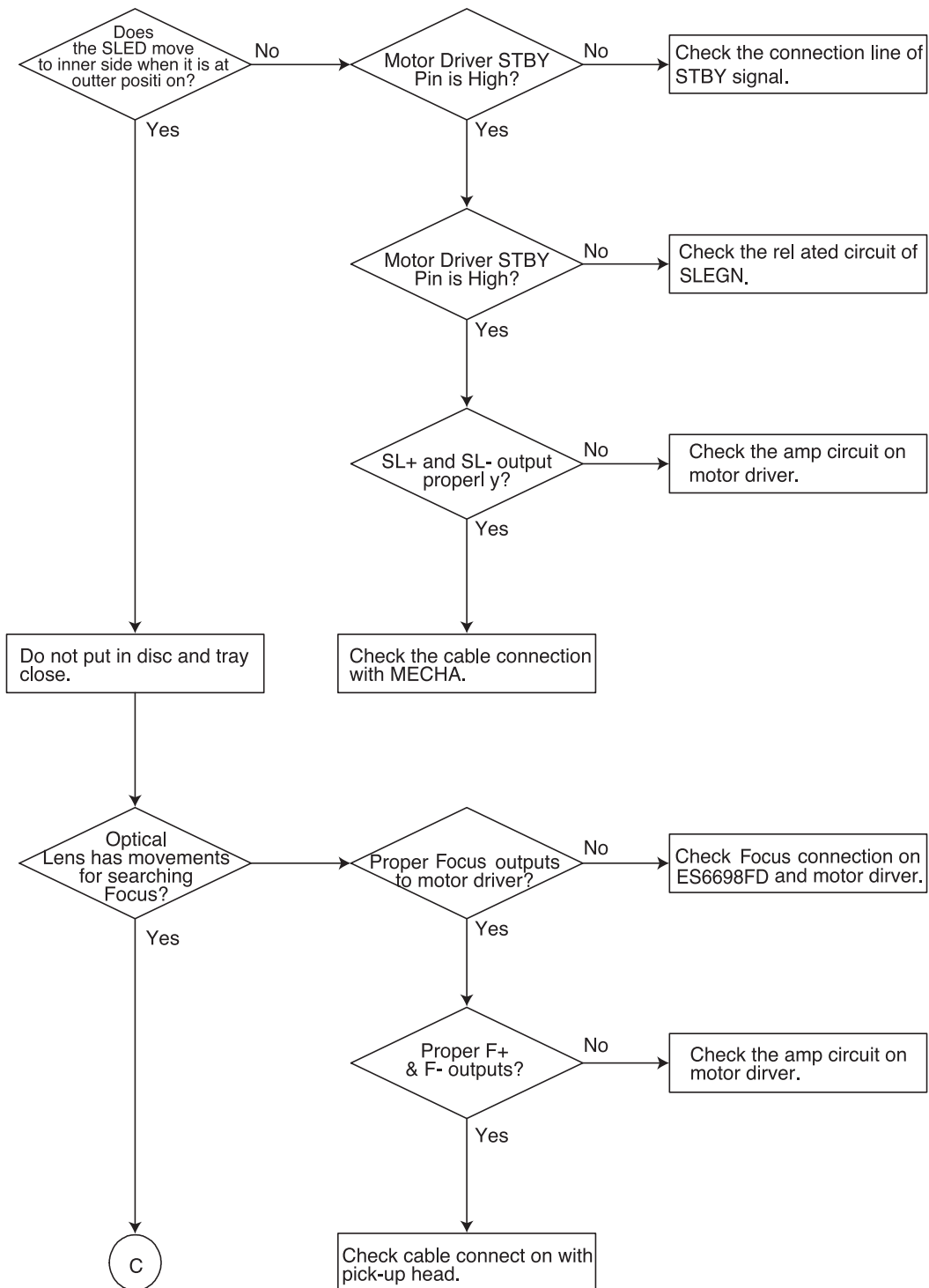

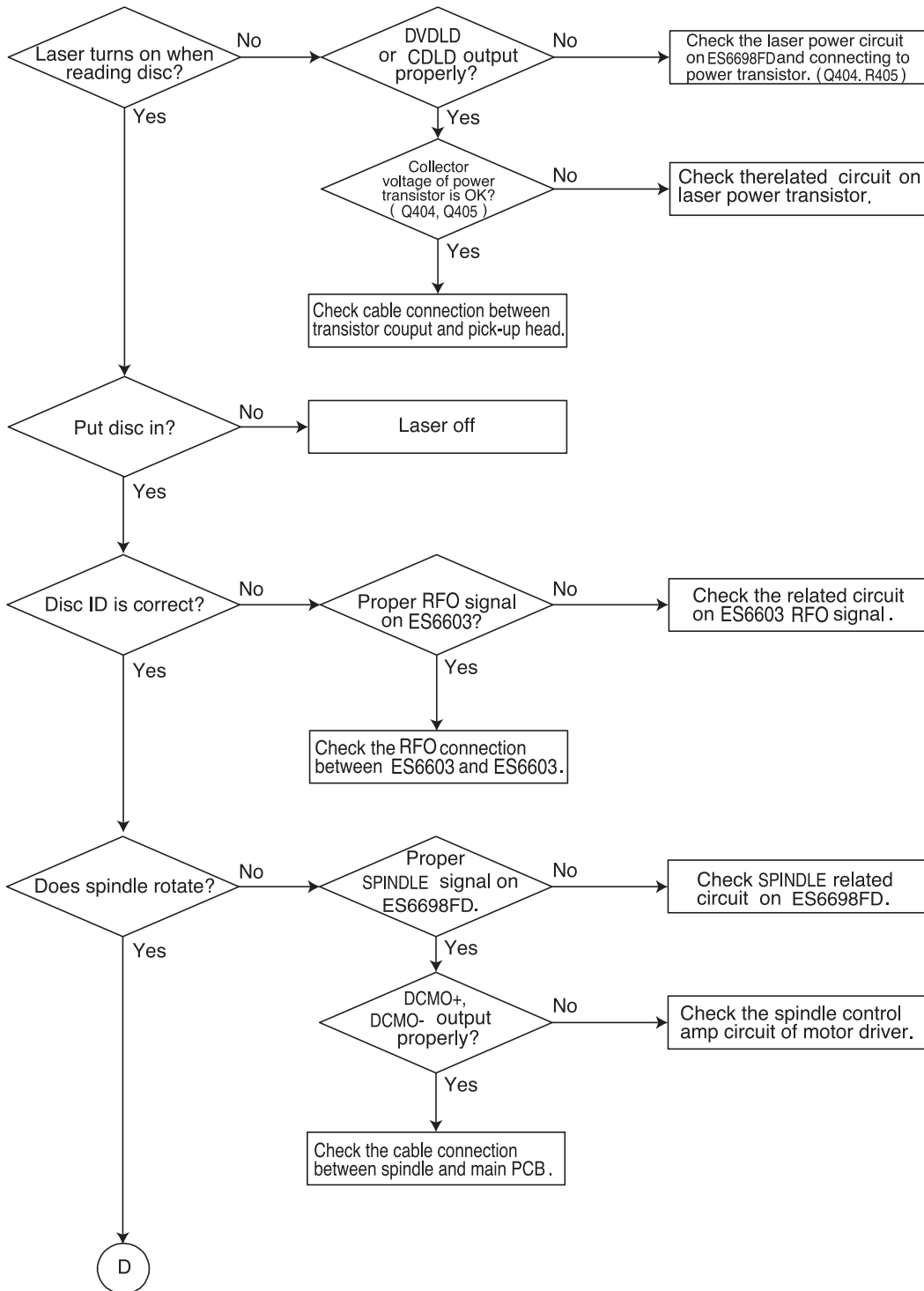

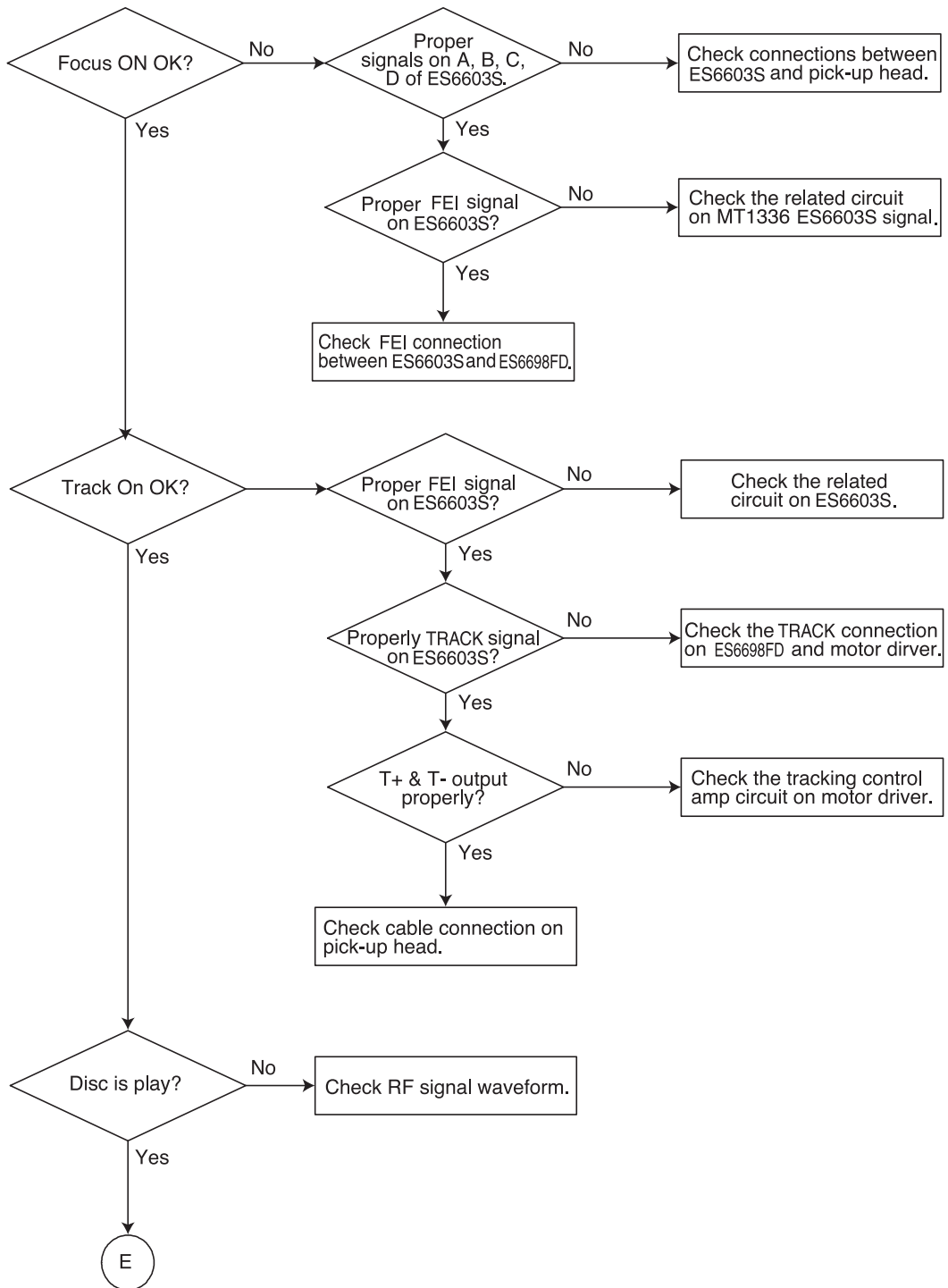

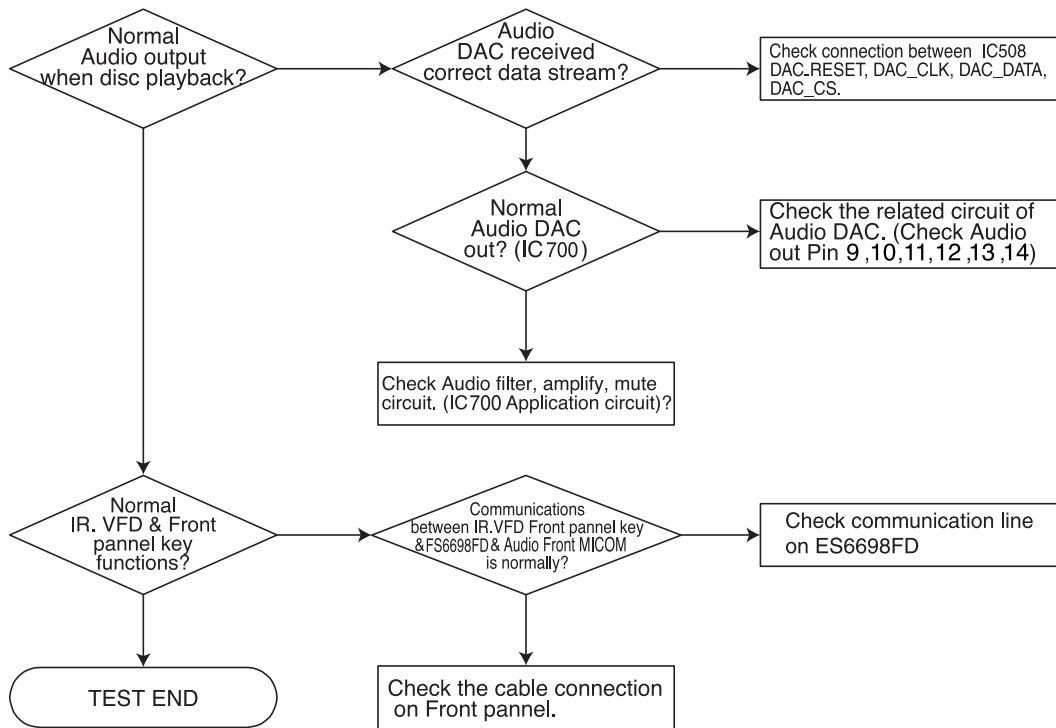

# INTERNAL BLOCK DIAGRAM of ICs

## • ES6603 (IC401) BLOCK DIAGRAM

Figure 1 depicts the ES6603 device pinout. The pound symbol (#) indicates an active-low signal.

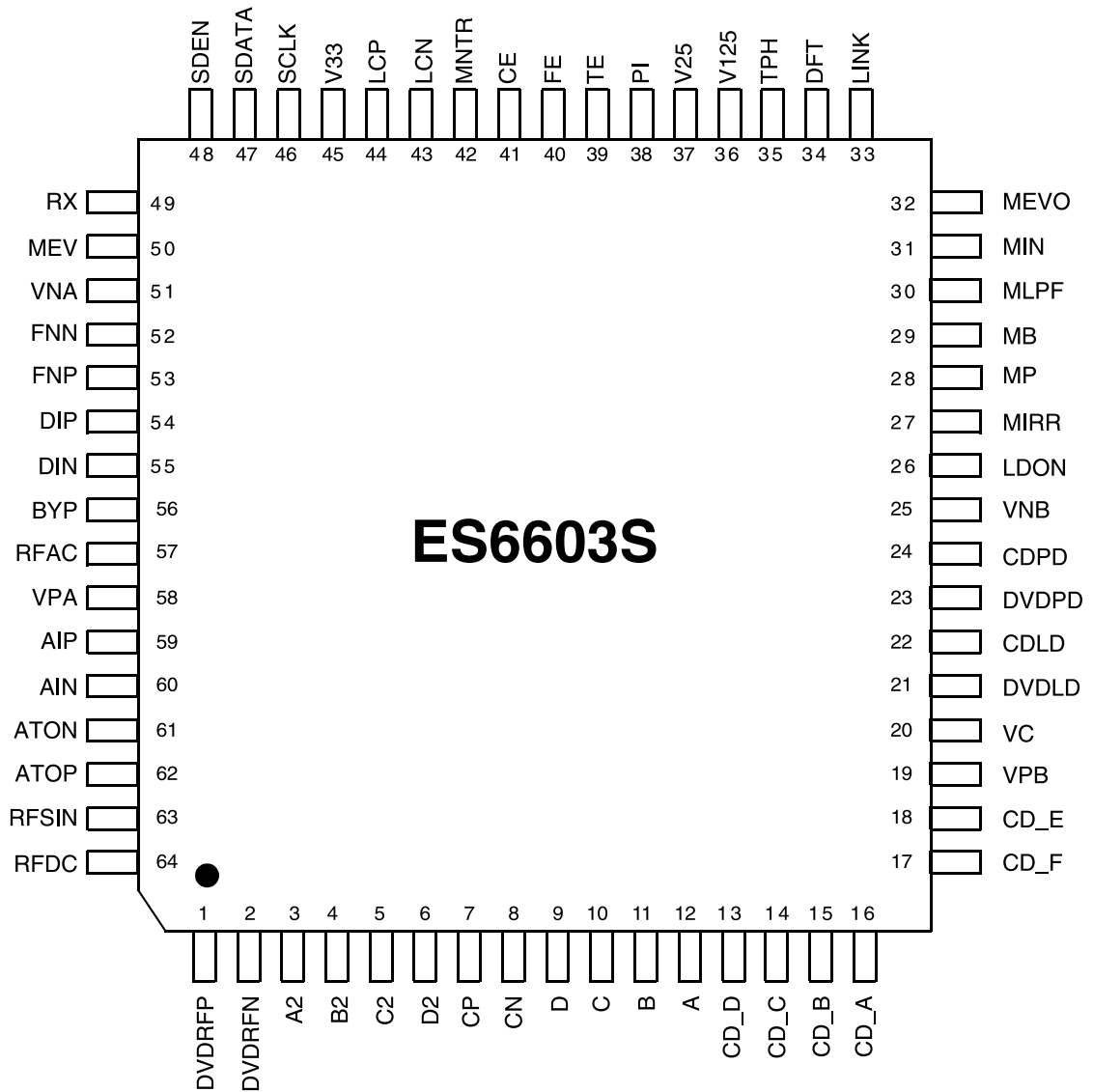



## ES6603 PIN DESCRIPTION

Table 1 lists the pin descriptions for the ES6603. The pound symbol (#) indicates an active-low signal.

**Table 1 ES6603 Pin Descriptions List**

Name	Pin Numbers	I/O	Definition
DVDRFP, DVDRFN	1, 2	I	Differential RF signal attenuator inputs.
A2, B2, C2, D2	3:6	I	AC coupled photo detector interface inputs for the differential phase detector (DPD) from the main beam photo matrix.
CP, CN	7, 8	—	Differential phase tracking low-pass filter pins. Connect CP to CN via capacitors.
D, C, B, A	9:12	I	Photo detector interface inputs from the main beam photo matrix.
CD_D, CD_C, CD_B, CD_A	13:16	I	CD photo detector interface inputs from the main beam photo matrix.
CD_F, CD_E	17, 18	I	CD photo detector interface inputs from the CD side beam photo detector; used for CD tracking detection.
VPB	19	P	Servo block power supply.
VC	20	O	Reference voltage out (VPB/2). Output impedance is less than 50Ω.
DVDLD	21	O	DVD APC output; controls laser power for DVD.
CDLD	22	O	CD APC output; controls laser power for CD.
DVDPD	23	I	DVD APC input.
CDPD	24	I	CD APC input.
VNB	25	G	Servo block ground.
LDON	26	I	APC On/Off control. A high level activates LD output. (open is low)
MIRR	27	O	Mirror detect output.
MP, MB	28, 29	I	Mirror top and bottom hold pins. Connected to VPB pin 19 via capacitors.
MLPF	30	I	Mirror low-pass filter pins. Connected to VPB pin 19 via a capacitor.
MIN	31	I	RF input signal for mirror. AC coupled inputs for the mirror detection circuit from MEVO pin 32.
MEVO	32	O	RFDC bottom envelope out. Pull-In or bottom clamped RF envelope signal output for mirror detection.
LINK	33	I,O	Linking Signal In/Mirror Monitor Out. In the linking area, the mirror and tracking error outputs are disabled when this pin goes high. When the monitor output signal is selected by the Control H register, mirror-related signals can be observed.
DFT	34	O	Defect output. When the Pull-In signal level is below the detection level, or when the RF signal level is below the detection level, the DFT output goes high. The defect output is selected by the serial port.
TPH	35	I	Pull-In top hold. Connected to VPB pin 19 via a capacitor.
V125	36	O	1.25V servo block reference voltage output.
V25	37	P	2.5V servo output reference power supply.
PI	38	O	Pull-In signal out. The summing signal output of A, B, C, D, or CD_A, CD_B, CD_C, or CD_D. Reference to V25/3.
TE	39	O	Tracking error output reference to V125 pin 36.
FE	40	O	Focusing error output reference to V125 pin 36.

**Table 1 ES6603 Pin Descriptions List (Continued)**

Name	Pin Numbers	I/O	Definition
CE	41	O	Center error output reference to V125 pin 36.
MNTR	42	O	Monitor out signal. Output is selectable by register settings.
LCN, LCP	43, 44	I	Lens shift offset cancellation low-pass filter pins. Connect LCN to LCP via a capacitor.
V33	4 5	P	3.3V output buffers power supply.
SCLK	46	I	Serial clock from ES66x8.
SDATA	47	I/O	Serial data I/O.
SDEN	48	I	Serial data enable. Enabled by an active-high signal.
RX	49	I	Reference resistor. Connected to ground via a 12.0k $\Omega$ , 1% resistor..
MEV	50	I	RFDC bottom envelope. Connected to VPA pin 58 via a capacitor.
VNA	51	G	RF block and serial port ground.
FNN, FNP	52, 53	O	Differential outputs of equalizer/filter.
DIP, DIN	54, 55	I	Differential analog inputs to the RF single-end output buffer and full wave rectifier.
BYP	56	I	AGC amplifier gain bypass. Tied to VPA via a capacitor.
RFAC	57	O	Single-ended RF output.
VPA	58	P	RF block and serial port power supply.
AIP, AIN	59, 60	I	Differential AGC amplifier inputs.
ATON, ATOP	61, 62	O	Differential attenuator outputs.
RFSIN	63	I	Single-ended RF signal attenuator input.
RFDC	64	O	Single-ended RF summing output.

## ES6603 DEVICE INTERFACES

Table 2 lists the device interfaces for the ES6603

**Table 2 ES6603 Device Interfaces**

Name	Pin Numbers	I/O	Definition
AGC Interface	59, 60	I	Differential AGC amplifier inputs [AIP] and [AIN].
Automatic Laser Power Control (APC) Interface	21	O	APC laser power control for DVD [DVDLD].
	22	O	APC laser power control for CD [CDLD].
	23	I	APC photo diode in for DVD [DVDDP].
	24	I	APC photo diode in for CD [CDPD].
	26	I	APC input on/off control [LDON].
CD/DVD Photo Detector Interface	3:6		DVD differential phase detector matrix inputs [A2], [B2], [C2], and [D2].
	9:12	I	DVD single-ended phase detector matrix inputs [A], [B], [C], and [D].
	13:16	I	CD photo detector interface inputs [CD_A], [CD_B], [CD_C] and [CD_D].
	17, 18	I	CD side beam photo detector tracking outputs [CD_E] and [CD_F].
Embedded Servo DSP Interface	26	I	APC input on/off control [LDON] from embedded servo DSP.
	33	I/O	Linking signal and mirror monitor control I/O [LINK].
	34	O	Defect output [DFT] to embedded servo DSP.
	38	O	Pull-In signal [PI] to embedded servo DSP.
	39	O	Tracking error [TE] to embedded servo DSP.
	40	O	Focusing error [FE] to embedded servo DSP.
	41	O	Center error [CE] to embedded servo DSP.
	46	I	Serial clock [SCLK] from embedded servo DSP.
	47	I/O	Serial data I/O [SDATA] for embedded servo DSP.
48	I	Serial data enable [SDEN] from embedded servo DSP.	
Filtering and Reference Voltage	7, 8	I	Differential phase tracking low-pass filters [CP] and [CN].
	20	O	DC bias reference voltage [VC].
	30	I	Mirror low-pass filter [MLPF].
	36	O	Servo block reference voltage [V125].
	43, 44	I	Lens shift offset cancellation low-pass filters [LCP] and [LCN].
	64	O	Single-ended RF summing output reference [RFDC].
Power and Ground	19	P	Servo block port power supply [VPB].
	25	G	Servo block ground [VNB].
	37	P	2.5V reference voltage servo output power supply [V25].
	45	P	3.3V output buffers power supply [V33].
	51	G	RF block and serial port ground [VNA].
	58	P	RF block and serial port power supply [VPA].
AGC and Filter Interface	1,2	I	Differential RF signal attenuator inputs [DVDRFP] and [DVDRFN].
	52, 53	O	Differential normal filter outputs [FNP] and [FNN].
	54, 55	I	Differential analog RF buffer inputs [DIP] and [DIN].
	57	O	Single-ended RF output [RFAC].
	63	I	Single-ended RF signal attenuator input [RFSIN].
	61, 62	O	Differential attenuator outputs [ATOP] and ATON].
Serial Port Interface	46	I	Serial clock from ES66x8 [SCLK].
	47	I/O	Serial data I/O [SDATA].
	48	I	Serial data enable [SDEN].

• BA5954FM (IC404)  
BLOCK DIAGRAM

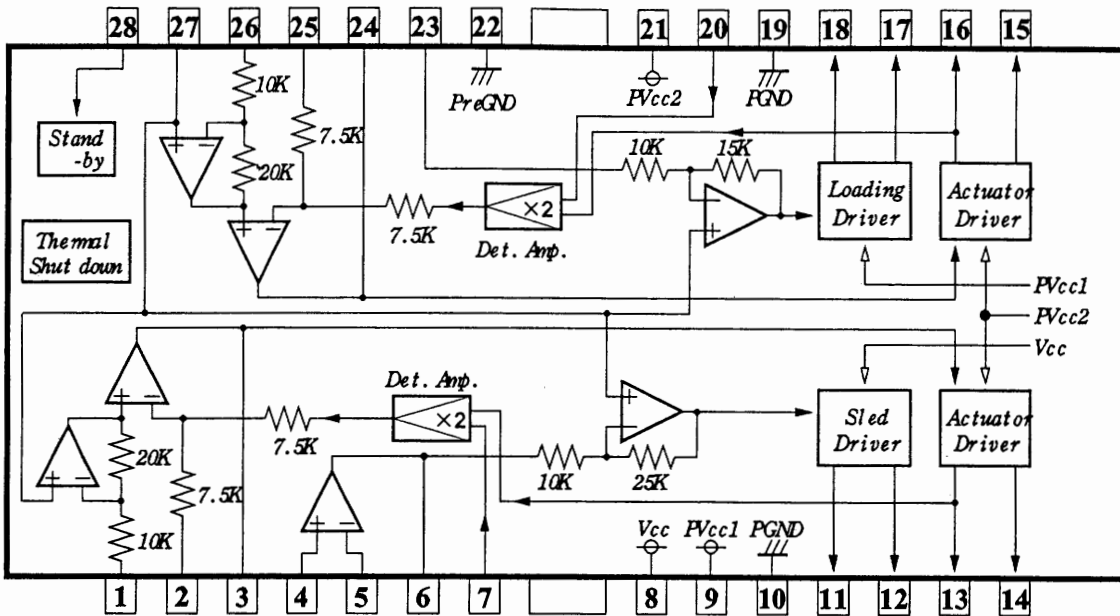
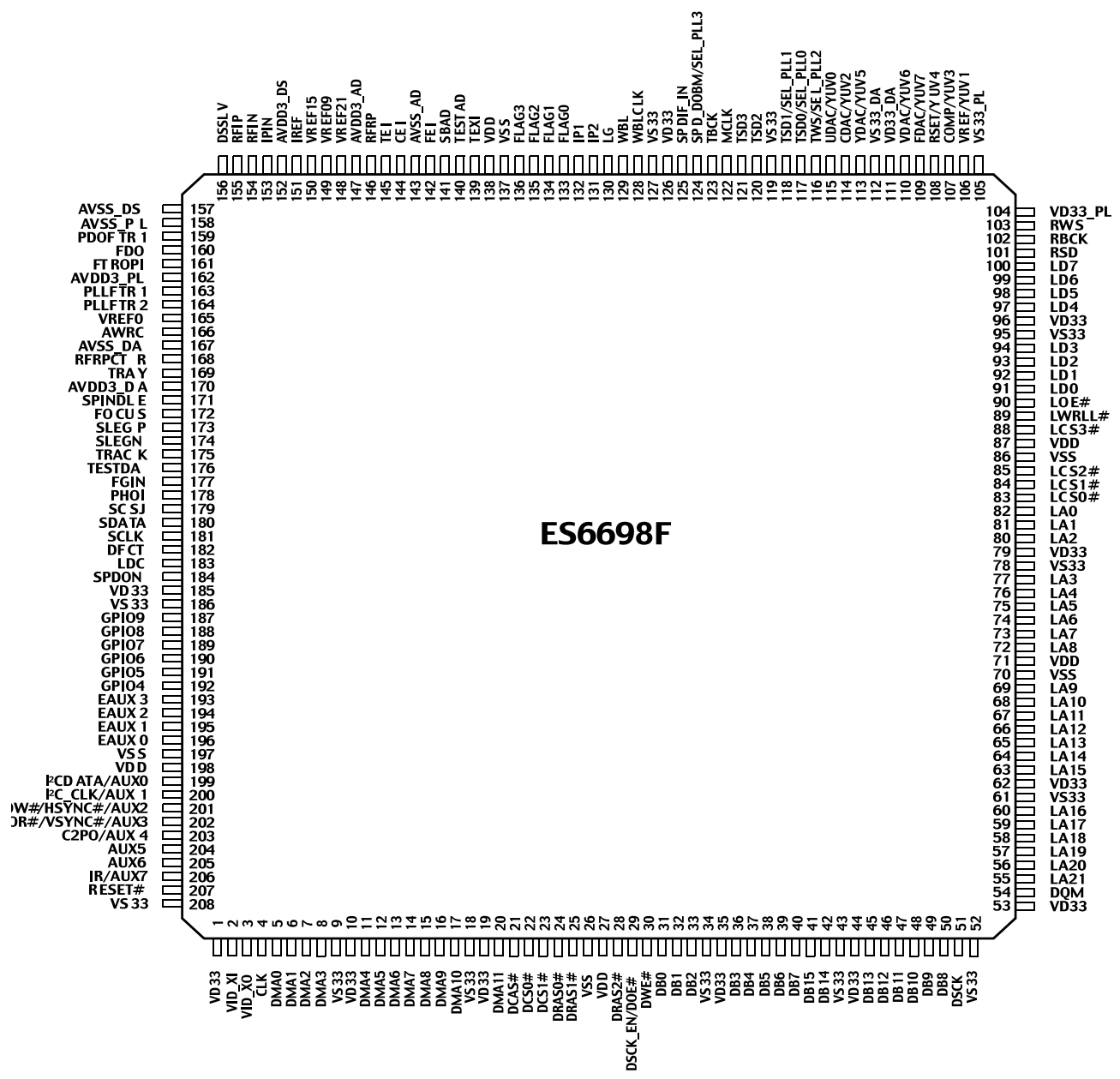

Figure 3

Pin description

No	Symbol	Function	No	Symbol	Function
1	VINFC	Input for focus driver	15	VOTK+	Non inverted output of tracking
2	CFCerr1	Connection with capacitor for error amplifier	16	VOTK-	Inverted output of tracking
3	CFCerr2		17	VOLD+	Non inverted output of loading
4	VINSL+	Non inverting Input for OP- amp	18	VOLD-	Inverted output of loading
5	VINSL-	Inverting input for OP- amp	19	PGND	GND for power block
6	VO SL	Output of OP- amp	20	VNFTK	Feedback for tracking driver
7	VNFFC	Feedback for focus driver	21	PVcc2	Vcc for power block of actuator
8	Vcc	Vcc for pre-drive block and power block of sled	22	PreGND	GND for pre-drive block
9	PVcc1	Vcc for power block of loading	23	VINLD	Input for loading driver
10	PGND	GND for power block	24	CTKerr2	Connection with capacitor for error amplifier
11	VO SL-	Inverted output of sled	25	CTKerr1	
12	VO SL+	Non inverted output of sled	26	VINTK	Input for tracking driver
13	VOFC-	Inverted output of focus	27	BIAS	Input for reference voltage
14	VOFC+	Non inverted output of focus	28	STBY	Input for stand-by control

• ES6698 (IC501)  
BLOCK DIAGRAM



## ES6698 PIN DESCRIPTION

Table 1 lists the pin descriptions for the ES6698.

Table 1 ES6698 Pin Description

Names	Pin Numbers	I/O	Definitions
VD33	1, 10, 19, 35, 44, 53, 62, 79, 96, 126, 185	P	I/O power supply.
VID_XI	2	I	Crystal input.
VID_XO	3	O	Crystal output.
CLK	4	I	System clock.
DMA[11:0]	5:8 11:17, 20	O	DRAM address bus.
VS33	9, 18, 34, 43, 52, 61, 78, 95, 119, 127, 186, 208	G	Ground for I/O power supply.
DCAS#	21	O	DRAM column address strobe (active-low).
DCS[1:0]#	22, 23	O	DRAM chip select (active-low).
DRAS[2:0]#	24, 25, 28	O	DRAM row address strobe (active-low).
VSS	26, 70, 86, 137, 197	G	Ground for core power supply.
VDD	27, 71, 87, 138, 198	P	Core power supply.
DSCK_EN	29	O	DRAM clock enable output.
DOE#		O	DRAM output enable (active-low).
DWE#	30	O	DRAM write enable (active-low).
DB[15:0]	31:33, 36:42, 45:50	I/O	DRAM data bus.
DSCK	51	O	Output clock to DRAM.
DQM	54	O	Data input/output mask.
LA[21:0]	55:60, 63:69, 72:77, 80:82	O	RISC port address bus.
LCS[3:0]#	83:85, 88	O	RISC port chip select (active-low).
LWRL#	89	O	RISC port low-byte write enable (active-low).
LOE#	90	O	RISC port output enable (active-low).
LD[7:0]	91:94, 97:100	I/O	RISC port data bus; (5V tolerant input).
RSD	101	I	Audio receive serial data; (5V tolerant input).
RBCK	102	I	Audio receive bit clock; (5V tolerant input).
RWS	103	I	Audio receive frame sync; (5V tolerant input).
VD33_PL	104	P	Power for PLL blocks.
VS33_PL	105	G	Ground for PLL blocks.
VREF	106	I	Internal voltage reference to video DAC.
YUV1		O	YUV pixel 1 output data.
COMP	107	I	Compensation input.
YUV3		O	YUV pixel 3 output data.

Table 1 ES6698 Pin Description (Continued)

Names	Pin Numbers	I/O	Definitions																																																																																																						
RSET	108	I	DAC current adjustment resistor input.																																																																																																						
YUV4		O	YUV pixel 4 output data.																																																																																																						
FDAC	109	O	Video DAC output. Refer to description and matrix for UDAC pin 115.																																																																																																						
YUV7		O	YUV pixel 7 output data.																																																																																																						
VDAC	110	O	Video DAC output. Refer to description and matrix for UDAC pin 115.																																																																																																						
YUV6		O	YUV pixel 6 output data.																																																																																																						
VD33_DA	111	P	Power for I/O power supply for VDAC.																																																																																																						
VS33_DA	112	G	Ground for I/O power supply for VDAC.																																																																																																						
YDAC	113	O	Video DAC output. Refer to description and matrix for UDAC pin 115.																																																																																																						
YUV5		O	YUV pixel 5 output data.																																																																																																						
CDAC	114	O	Video DAC output. Refer to description and matrix for UDAC pin 115.																																																																																																						
YUV2		O	YUV pixel 2 output data.																																																																																																						
UDAC	115	O	Video DAC output. <table border="1" style="margin-left: 20px;"> <thead> <tr> <th>Pin</th> <th>109</th> <th>110</th> <th>113</th> <th>114</th> <th>115</th> </tr> <tr> <th>Value</th> <th>F DAC</th> <th>V DAC</th> <th>Y DAC</th> <th>C DAC</th> <th>U DAC</th> </tr> </thead> <tbody> <tr><td>0</td><td>CVBS/Chroma</td><td>CVBS1</td><td>Y</td><td>C</td><td>N/A</td></tr> <tr><td>1</td><td>CVBS/Chroma</td><td>CVBS1</td><td>Y</td><td>C</td><td>CVBS2</td></tr> <tr><td>2</td><td>CVBS/Chroma</td><td>N/A</td><td>Y</td><td>C</td><td>N/A</td></tr> <tr><td>3</td><td>CVBS/Chroma</td><td>CVBS1</td><td>N/A</td><td>N/A</td><td>CVBS2</td></tr> <tr><td>4</td><td>CVBS/Chroma</td><td>CVBS1</td><td>N/A</td><td>N/A</td><td>N/A</td></tr> <tr><td>5</td><td>CVBS/Chroma</td><td>CVBS1</td><td>Y</td><td>Pb</td><td>Pr</td></tr> <tr><td>6</td><td>CVBS/Chroma</td><td>N/A</td><td>Y</td><td>Pb</td><td>Pr</td></tr> <tr><td>7</td><td>N/A</td><td>SYNC</td><td>G</td><td>B</td><td>R</td></tr> <tr><td>8</td><td>CVBS/Chroma</td><td>Chroma</td><td>Y</td><td>Pb</td><td>Pr</td></tr> <tr><td>9</td><td>CVBS</td><td>CVBS1</td><td>G</td><td>B</td><td>R</td></tr> <tr><td>10</td><td>CVBS</td><td>CVBS1</td><td>G</td><td>R</td><td>B</td></tr> <tr><td>11</td><td>N/A</td><td>SYNC</td><td>G</td><td>R</td><td>B</td></tr> <tr><td>12</td><td>CVBS/Chroma</td><td>N/A</td><td>Y</td><td>Pr</td><td>Pb</td></tr> <tr><td>13</td><td>CVBS/Chroma</td><td>CVBS1</td><td>Y</td><td>Pr</td><td>Pb</td></tr> <tr><td>14</td><td>Chroma</td><td>Y</td><td>G</td><td>R</td><td>B</td></tr> </tbody> </table> <p>F: CVBS/chroma signal for simultaneous mode.  Y: Luma component for YUV and Y/C processing.  C: Chrominance signal for Y/C processing.  U: Chrominance component signal for YUV mode.  V: Chrominance component signal for YUV mode.</p>	Pin	109	110	113	114	115	Value	F DAC	V DAC	Y DAC	C DAC	U DAC	0	CVBS/Chroma	CVBS1	Y	C	N/A	1	CVBS/Chroma	CVBS1	Y	C	CVBS2	2	CVBS/Chroma	N/A	Y	C	N/A	3	CVBS/Chroma	CVBS1	N/A	N/A	CVBS2	4	CVBS/Chroma	CVBS1	N/A	N/A	N/A	5	CVBS/Chroma	CVBS1	Y	Pb	Pr	6	CVBS/Chroma	N/A	Y	Pb	Pr	7	N/A	SYNC	G	B	R	8	CVBS/Chroma	Chroma	Y	Pb	Pr	9	CVBS	CVBS1	G	B	R	10	CVBS	CVBS1	G	R	B	11	N/A	SYNC	G	R	B	12	CVBS/Chroma	N/A	Y	Pr	Pb	13	CVBS/Chroma	CVBS1	Y	Pr	Pb	14	Chroma	Y	G	R	B
Pin		109	110	113	114	115																																																																																																			
Value		F DAC	V DAC	Y DAC	C DAC	U DAC																																																																																																			
0		CVBS/Chroma	CVBS1	Y	C	N/A																																																																																																			
1		CVBS/Chroma	CVBS1	Y	C	CVBS2																																																																																																			
2		CVBS/Chroma	N/A	Y	C	N/A																																																																																																			
3		CVBS/Chroma	CVBS1	N/A	N/A	CVBS2																																																																																																			
4		CVBS/Chroma	CVBS1	N/A	N/A	N/A																																																																																																			
5		CVBS/Chroma	CVBS1	Y	Pb	Pr																																																																																																			
6		CVBS/Chroma	N/A	Y	Pb	Pr																																																																																																			
7		N/A	SYNC	G	B	R																																																																																																			
8		CVBS/Chroma	Chroma	Y	Pb	Pr																																																																																																			
9		CVBS	CVBS1	G	B	R																																																																																																			
10		CVBS	CVBS1	G	R	B																																																																																																			
11		N/A	SYNC	G	R	B																																																																																																			
12	CVBS/Chroma	N/A	Y	Pr	Pb																																																																																																				
13	CVBS/Chroma	CVBS1	Y	Pr	Pb																																																																																																				
14	Chroma	Y	G	R	B																																																																																																				
YUV0		O	YUV pixel 0 output data.																																																																																																						

**Table 1 ES6698 Pin Description (Continued)**

Names	Pin Numbers	I/O	Definitions																																			
TWS	116	O	Audio transmit frame sync output.																																			
SEL_PLL2		I	System and DSCK output clock frequency selection is made at the rising edge of RESET#. The matrix below lists the available clock frequencies and their respective PLL bit settings. Strapped to VCC or ground via 4.7-kΩ resistor; read-only during reset. <table border="1" style="margin-left: auto; margin-right: auto;"> <thead> <tr> <th>SEL_PLL2</th> <th>SEL_PLL1</th> <th>SEL_PLL0</th> <th>Clock Type (MHz)</th> </tr> </thead> <tbody> <tr> <td>0</td> <td>0</td> <td>0</td> <td>CLK X4.5</td> </tr> <tr> <td>0</td> <td>0</td> <td>1</td> <td>CLK X5.0</td> </tr> <tr> <td>0</td> <td>1</td> <td>0</td> <td>Bypass</td> </tr> <tr> <td>0</td> <td>1</td> <td>1</td> <td>CLK X4.0</td> </tr> <tr> <td>1</td> <td>0</td> <td>0</td> <td>CLK X4.25</td> </tr> <tr> <td>1</td> <td>0</td> <td>1</td> <td>CLK X4.75</td> </tr> <tr> <td>1</td> <td>1</td> <td>0</td> <td>CLK X5.5</td> </tr> <tr> <td>1</td> <td>1</td> <td>1</td> <td>CLK X6.0</td> </tr> </tbody> </table>	SEL_PLL2	SEL_PLL1	SEL_PLL0	Clock Type (MHz)	0	0	0	CLK X4.5	0	0	1	CLK X5.0	0	1	0	Bypass	0	1	1	CLK X4.0	1	0	0	CLK X4.25	1	0	1	CLK X4.75	1	1	0	CLK X5.5	1	1	1
SEL_PLL2	SEL_PLL1	SEL_PLL0	Clock Type (MHz)																																			
0	0	0	CLK X4.5																																			
0	0	1	CLK X5.0																																			
0	1	0	Bypass																																			
0	1	1	CLK X4.0																																			
1	0	0	CLK X4.25																																			
1	0	1	CLK X4.75																																			
1	1	0	CLK X5.5																																			
1	1	1	CLK X6.0																																			
TSD0	117	O	Audio transmit serial data port 0.																																			
SEL_PLL0		I	Refer to the description and matrix for SEL_PLL2 pin 116.																																			
TSD1	118	O	Audio transmit serial data port 1.																																			
SEL_PLL1		I	Refer to the description and matrix for SEL_PLL2 pin 116.																																			
TSD[2:3]	120, 121	O	Audio transmit serial data ports 2 and 3.																																			
MCLK	122	I/O	Audio master clock for audio DAC.																																			
TBCK	123	O	Audio transmit bit clock.																																			
SPD_DOBM	124	O	S/PDIF output.																																			
SEL_PLL3		I	Clock source select. Strapped to VCC or ground via 4.7-kΩ resistor; read only during reset. <table border="1" style="margin-left: auto; margin-right: auto;"> <thead> <tr> <th>SEL_PLL3</th> <th>Clock Source</th> </tr> </thead> <tbody> <tr> <td>0</td> <td>Crystal oscillator</td> </tr> <tr> <td>1</td> <td>CLK input</td> </tr> </tbody> </table>	SEL_PLL3	Clock Source	0	Crystal oscillator	1	CLK input																													
SEL_PLL3	Clock Source																																					
0	Crystal oscillator																																					
1	CLK input																																					
SPDIF_IN	125	I	S/PDIF input; (5V tolerant input).																																			
WBLCLK	128	O	DVD-RAM wobble detector circuit clock source to preamp.																																			
WBL	129	O	DVD-RAM wobble output.																																			
LG	130	O	DVD-RAM land/groove flag.																																			
IP2	131	I	DVD-RAM header position index 2.																																			
IP1	132	I	DVD-RAM header position index 1.																																			
FLAG[3:0]	133:136	O	To monitor servo status.																																			
TEXI	139	I	High-speed tracking error input.																																			
TESTAD	140	I	Test AD input.																																			
SBAD	141	I	Sub-beam addition input signal.																																			
FEI	142	I	Focus input error signal.																																			



**Table 1 ES6698 Pin Description (Continued)**

Names	Pin Numbers	I/O	Definitions
AVSS_AD	143	G	Analog ground for ADC block.
CEI	144	I	Center error input signal.
TEI	145	I	Tracking error input signal.
RFRP	146	I	RF ripple/envelope input signal.
AVDD3_AD	147	P	Analog power supply for ADC block.
VREF21	148	O	2.1V reference voltage.
VREF09	149	O	0.9V reference voltage.
VREF15	150	O	1.5V reference voltage.
IREF	151	I	Servo data PLL interface reference current generator. Connect a resistor between this pin and ground to set reference current.
AVDD3_DS	152	P	Analog power supply for data slicer block.
IPIN	153	I	Inverting input of data slicer.
RFIN	154	I	Analog RF signal input after passing through equalizer (minus).
RFIP	155	I	Analog RF signal input after passing through equalizer (plus).
DSSLV	156	O	Data slicer level output.
AVSS_DS	157	G	Analog ground for data slicer block.
AVSS_PL	158	G	Analog ground for data PLL block.
PDOFTR1	159	O	Servo data PLL phase detector filter pin number 1.
FDO	160	O	Servo data PLL output node of frequency detector charge pump.
FTROPI	161	I	Servo data PLL input node of loop filter OP circuit.
AVDD3_PL	162	P	Analog power supply for data PLL block.
PLLFTR1	163	I	Servo data PLL loop filter pin number 1.
PLLFTR2	164	I	Servo data PLL loop filter pin number 2.
VREF0	165	O	Servo data PLL reference voltage output.
AWRC	166	I/O	Auto wide range control VCO signal from/to AWRC DAC.
AVSS_DA	167	G	Analog ground for DAC part.
RFRPCTR	168	I/O	Central level of RFRP.
TRAY	169	O	Output voltage level for tray buffer IC.
AVDD3_DA	170	P	Analog power supply for DAC part.
SPINDLE	171	O	Output voltage level for spindle buffer IC.
FOCUS	172	O	Output voltage level for focus buffer IC.
SLEGP	173	O	Output voltage level for Sledge buffer IC (plus).
SLEGN	174	O	Output voltage level for Sledge buffer IC (minus).
TRACK	175	O	Output voltage level for tracking buffer IC.
TESTDA	176	O	Test DA output.
FGIN	177	I	Spindle hall sensor input.

**Table 1 ES6698 Pin Description (Continued)**

Names	Pin Numbers	I/O	Definitions
PHOI	178	I	Sledge photo interrupt signal input.
SCSJ	179	O	Chip selection signal to RF chip (serial data enable).
SDATA	180	I/O	Data signal from/to RF chip.
SCLK	181	O	Serial clock source to RF chip.
DFCT	182	I	Defect flag input signal.
LDC	183	O	Laser diode on/off control output.
SPDON	184	O	Spindle power driver on/off control output.
GPIO[9:4]	187:192	I/O	General-purpose input/output used for servo control; (5V tolerant input).
EAUX[3:0]	193:196	I/O	Extended auxilliary ports; (5V tolerant input).
I <sup>2</sup> C DATA	199	I/O	I <sup>2</sup> C data I/O; (5V tolerant input).
AUX0		I/O	Auxiliary port (open collector); (5V tolerant input).
I <sup>2</sup> C_CLK	200	I/O	I <sup>2</sup> C clock I/O; (5V tolerant input).
AUX1		I/O	Auxiliary port (open collector); (5V tolerant input).
IOW#	201	O	I/O Write strobe (LCS1) (active-low).
HSYNC#		I/O	Horizontal sync (active-low); (5V tolerant input).
AUX2		I/O	Auxiliary port; (5V tolerant input).
IOR#	202	O	I/O Read strobe (LCS1) (active-low).
VSYNC#		I/O	Vertical sync (active-low); (5V tolerant input).
AUX3		I/O	Auxiliary port; (5V tolerant input).
C2PO	203	I	Error correction flag from CD; (5V tolerant input).
AUX4		I/O	Auxiliary port; (5V tolerant input).
AUX[5:6]	204, 205	I/O	Auxiliary ports; (5V tolerant input).
IR	206	I	Infrared remote control input; (5V tolerant input).
AUX7		I/O	Auxiliary port; (5V tolerant input).
RESET#	207	I	Reset input (active-low); (5V tolerant input).

## ES6698 DEVICE INTERFACES

Table 2 lists the device interfaces for the ES6698

**Table 2 ES6698 Device Interfaces**

Name	Pin Numbers	I/O	Definition
Audio Port Interface	101	I	Audio receive serial data input [RSD]; (5V tolerant input).
	102	I	Audio receive bit clock input [RBCK]; (5V tolerant input).
	103	I	Audio receive frame sync input [RWS]; (5V tolerant input).
	116	O	Audio transmit frame sync output [TWS].
	117, 118, 120, 121	O	Audio transmit serial data outputs [TSD[3:0]].
	122	I/O	Audio DAC master clock [MCLK].
	123	O	Audio transmit bit clock output [TBCK].
	124	O	Sony/Philips Digital Interface audio output [SPD_DOBM].
	125	I	Sony/Philips Digital Interface audio input [SPDIF_IN]; (5V tolerant input).
Auxiliary Port Interface	193:196	I/O	Extended auxilliary ports [EAUX[3:0]]; (5V tolerant input).
	199, 200	I/O	Open collectors [AUX[1:0]]; (5V tolerant input).
	201:206	I/O	Primary auxiliary port I/Os [AUX[7:2]]; (5V tolerant input).
Clock Interface and Reset	2	I	27-MHz crystal clock input [VID_XI].
	3	O	27-MHz crystal clock output [VID_XO]
	4	I	System clock [CLK].
	29	O	DRAM clock enable output [DSCK_EN].
	51	O	Output clock [DSCK] to video memory (DRAM).
	116:118	I	Clock frequency select PLL outputs [SEL_PLL[2:0]].
	207	I	Reset input (active-low) [RESET#]; (5V tolerant input).
Display Interface	106:110, 113:115	O	Pixel data outputs [YUV[7:0]].
	201	I/O	Horizontal sync [HSYNC#].
	202	I/O	Vertical sync [VSYNC#].
EPROM/Flash ROM and RISC Port Interface	55:60, 63:69, 72:77, 80:82	O	RISC port address bus [LA[21:0]] to EPROM or Flash memory.
	83:85	O	RISC port chip select outputs [LCS[2:0]#] to EPROM or Flash memory.
	89	O	RISC port low-byte write enable output [LWRL#] to EPROM or Flash memory.
	90	O	RISC port output enable [LOE#] to EPROM and Flash memory.
	91:94, 97:100	I/O	RISC port data bus [LD[7:0]] to EPROM or Flash memory; (5V tolerant input).
Filter and Reference Voltage Interface	106	I	Video DAC reference voltage input [VREF].
	107	I	Compensation input [COMP].
Front Panel Display Interface	206	I	Infrared remote control input [IR]; (5V tolerant input).

Name	Pin Numbers	I/O	Definition
General-Purpose	187:192	I/O	General-purpose I/O [GPIO[9:4]]; (5V tolerant input).
I <sup>2</sup> C Bus Interface	199	I/O	I <sup>2</sup> C data I/O [I2C_DATA]; (5V tolerant input).
	200	I/O	I <sup>2</sup> C clock I/O [I2C_CLK]; (5V tolerant input).
Power and Ground	1, 10, 19, 35, 44, 53, 62, 79, 96, 126, 185	P	I/O power supply [VD33].
	9, 18, 34, 43, 52, 61, 78, 95, 119, 127, 186, 208	G	I/O ground [VS33].
	26, 70, 86, 137, 197	G	Ground for core power [VSS].
	27, 71, 87, 138, 198	P	Core power supply [VDD].
	104	P	Power supply for PLL block. [VD33_PL].
	105	G	Ground for PLL block [VS33_PL].
	111	P	Power supply for video DAC [VD33_DA].
	112	G	Ground for video DAC [VS33_DA].
	143	G	Analog ground for ADC [AVSS_AD].
	147	P	Analog power supply for ADC [AVDD3_AD].
	152	P	Analog power supply for data slicer [AVDD3_DS].
	157	G	Analog ground for data slicer [AVSS_DS].
	158	G	Analog ground for data PLL [AVSS_PL].
	162	P	Analog power supply for data PLL [AVDD3_PL].
	167	G	Analog ground for DAC [AVSS_DA].
170	P	Analog power supply for DAC [AVDD3_DA].	
Serial Port Interface	203	I	C2PO error correction flag from CD [C2PO]; (5V tolerant input).
Servo Data Slicer Interface	153	I	Inverting input of data slicer [IPIN].
	154	I	Analog RF signal input after passing through equalizer (minus) [RFIN].
	155	I	Analog RF signal input after passing through equalizer (plus) [RFIP].
	156	O	Data slicer level output [DSSLV].

**Table 2 ES6698 Device Interfaces (Continued)**

Name	Pin Numbers	I/O	Definition
Servo DAC Interface	166	I/O	Auto wide range control VCO signal from/to AWRC DAC [AWRC].
	168	I/O	Central level of RFRP [RFRPCTR].
	169	O	Output voltage level for tray buffer IC [TRAY].
	171	O	Output voltage level for spindle buffer IC [SPINDLE].
	172	O	Output voltage level for focus buffer IC [FOCUS].
	173	O	Output voltage level for Sledge buffer IC (plus) [SLEGP].
	174	O	Output voltage level for Sledge buffer IC (minus) [SLEGN].
	175	O	Output voltage level for tracking buffer IC [TRACK].
	176	O	Test DA output [TESTDA].
Servo Comparator Interface	139	I	High-speed tracking error input [TEXI].
Servo ADC Interface	140	I	Test AD input [TESTAD].
	141	I	Sub-beam addition input signal [SBAD].
	142	I	Focus input error signal [FEI].
	144	I	Center error input signal [CEI].
	145	I	Tracking error input signal [TEI].
	146	I	RF ripple/envelope input signal [RFRP].
	148	O	2.1V reference voltage [VREF21].
	149	O	0.9V reference voltage [VREF09].
	150	I	1.5V reference voltage [VREF15].
Servo PLL Interface	151	I	Servo data PLL interface reference current generator. Connect a resistor between this pin and ground to set reference current [IREF].
	159	O	Servo data PLL phase detector filter pin number 1 [PDOFTR1].
	160	O	Servo data PLL output node of frequency detector charge pump [FDO].
	161	I	Servo data PLL input node of loop filter OP circuit FTROPI].
	163	I	Servo data PLL loop filter pin number 1 [PLLFTR1].
	164	I	Servo data PLL loop filter pin number 2 [PLLFTR2].
	165	O	Servo data PLL reference voltage output [VREF0].

**Table 2 ES6698 Device Interfaces (Continued)**

Name	Pin Numbers	I/O	Definition
Servo Control and Data Interface	133:136	O	To monitor servo status [FLAG[3:0]].
	177	I	Spindle hall sensor input [FGIN].
	178	I	Sledge photo interrupt signal input [PHOI].
	179	O	Chip selection signal to RF chip (serial data enable) [SCSJ].
	180	I/O	Data signal from/to RF chip [SDATA].
	181	O	Serial clock source to RF chip [SCLK].
	182	I	Defect flag input signal [DFCT].
	183	O	Laser diode on/off control output [LDC].
	184	O	Spindle power driver on/off control output [SPDON].
	187:192	I/O	General-purpose input/output used for servo control [GPIO[9:4]]; (5V tolerant input).
Servo DVD-RAM Interface	128	O	DVD-RAM wobble detector circuit clock source to preamp [WBLCLK].
	129	O	DVD-RAM wobble output [WBL].
	130	O	DVD-RAM land/groove flag [LG].
	131	I	DVD-RAM header position index 2 [IP2].
	132	I	DVD-RAM header position index 1 [IP1].
System Memory Interface	5:8, 11:17, 20	O	DRAM address bus [DMA[11:0]].
	21	O	Memory column address strobe output [DCAS#].
	22, 23	O	DRAM chip select outputs [DCS[1:0]#].
	24, 25, 28	O	Memory row address strobe output [DRAS[2:0]#].
	29	O	Memory output enable [DOE#].
	30	O	Memory write enable output [DWE#].
	31:33, 36:42, 45:50	I/O	Memory data bus [DB[15:0]].
	51	O	Output clock to DRAM [DSCK].
54	O	Memory data I/O mask output [DQM].	
Video DAC Interface	109	O	CVBS/chroma signal [FDAC] for simultaneous mode.
	110	O	Composite component signal [VDAC] for YUV mode.
	113	O	Luma component signal [YDAC] for YUV mode and Y/C processing.
	114	O	Chrominance component signal [CDAC] for Y/C processing.
	115	O	Chrominance component signal [UDAC] for YUV mode.

# □ DVD BLOCK DIAGRAM

## • ESS 3-CHANGER SYSTEM BLOCK DIAGRAM

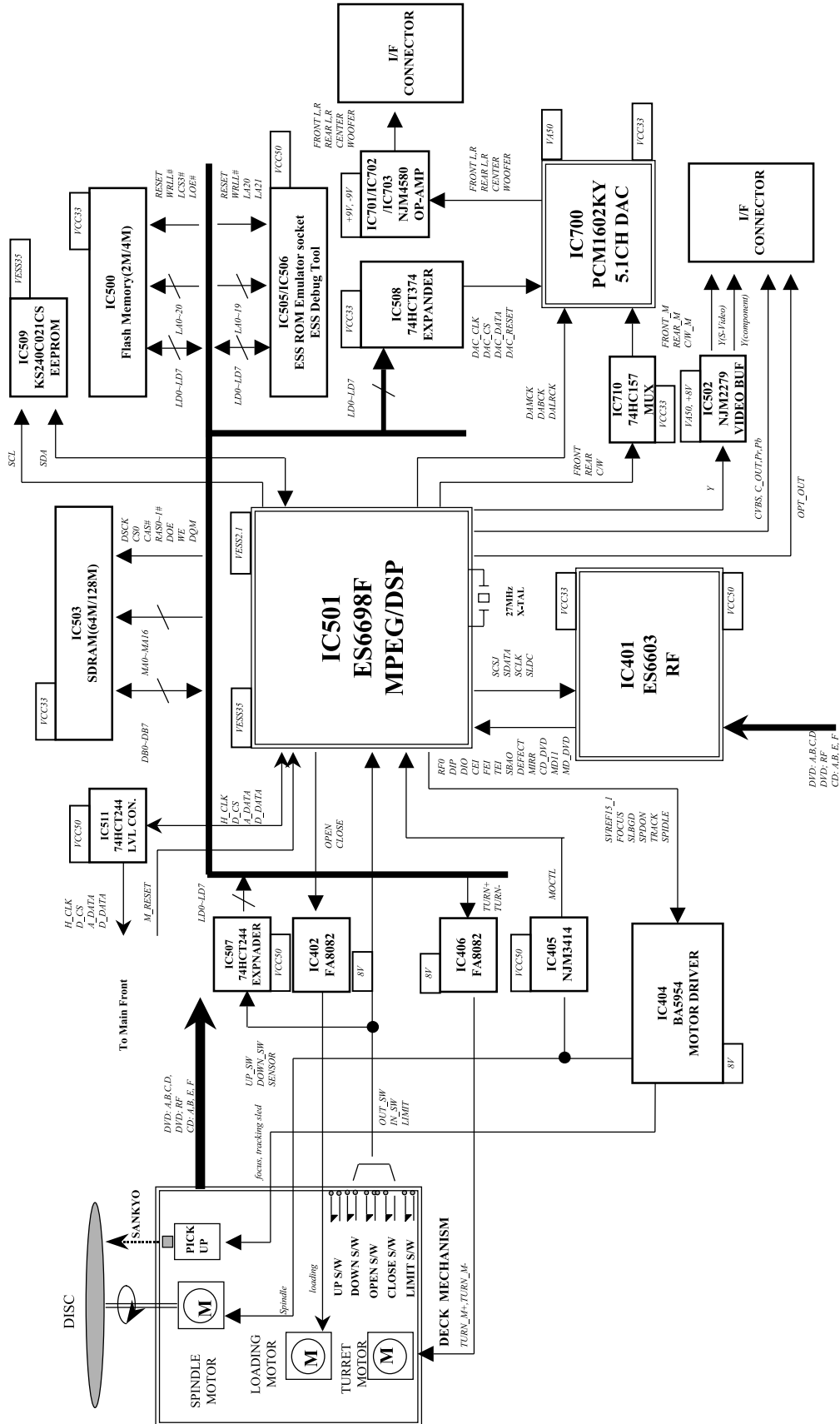

# • ESS 3-CHANGER MEMORY & HOST I/F BLOCK DIAGRAM

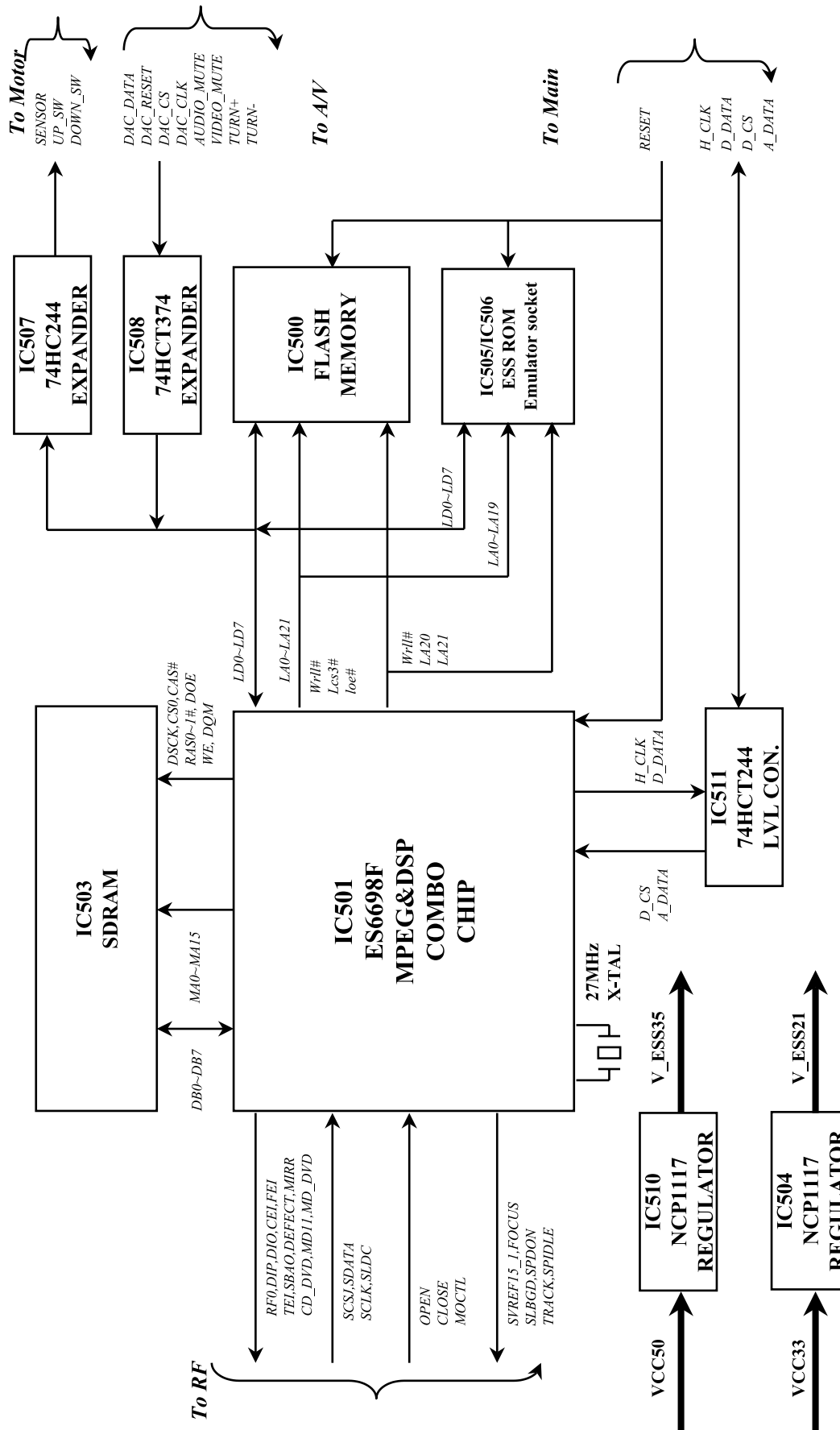



• **ESS 3-CHANGER SERVO & MOTOR BLOCK DIAGRAM**

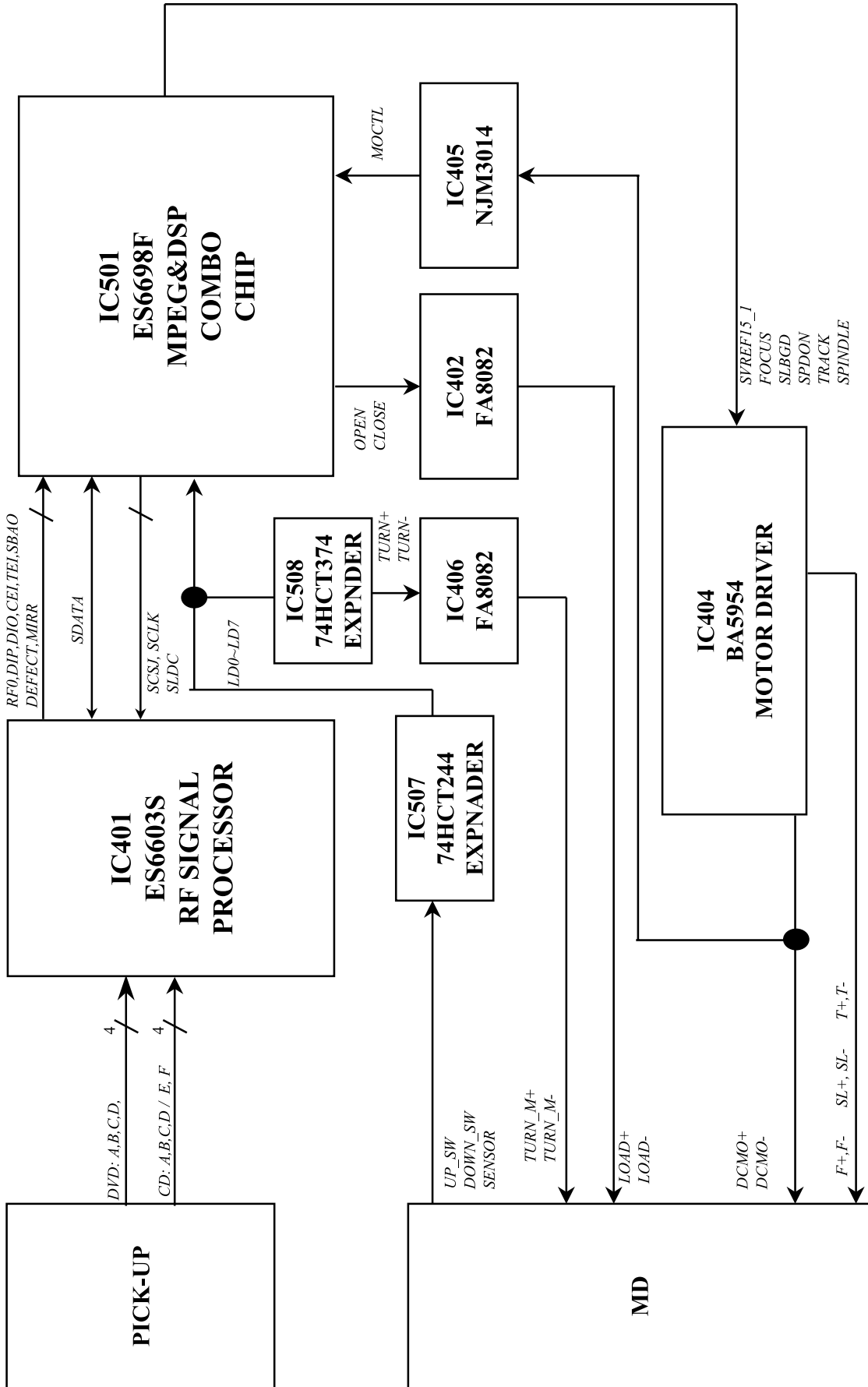

# • ESS 3-CHANGER A/V SYSTEM BLOCK DIAGRAM

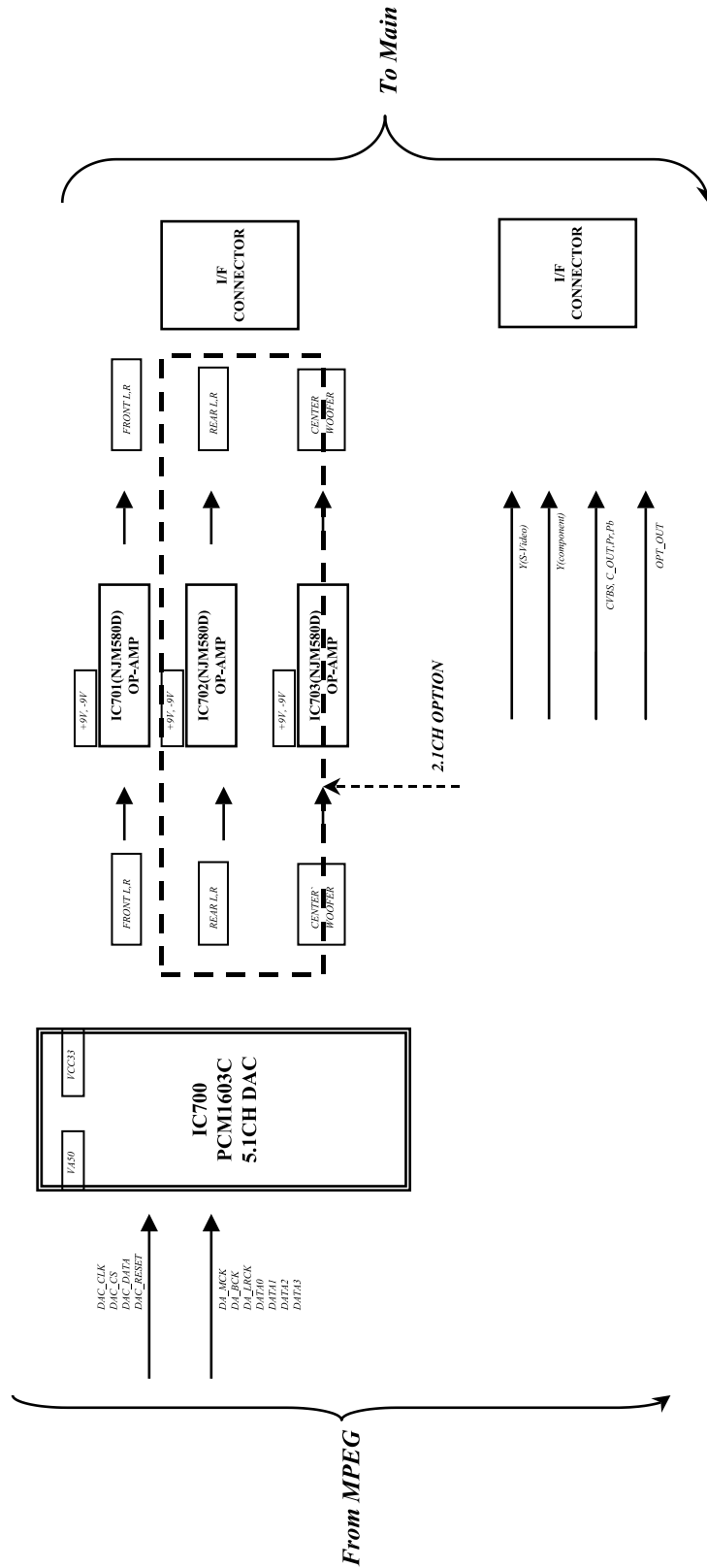

## □ REPAIRS REGARDING CD MECHANISM

### • IMPROVED MECHOD-WHEN THE TRAY GEARS WERE DISTORTED

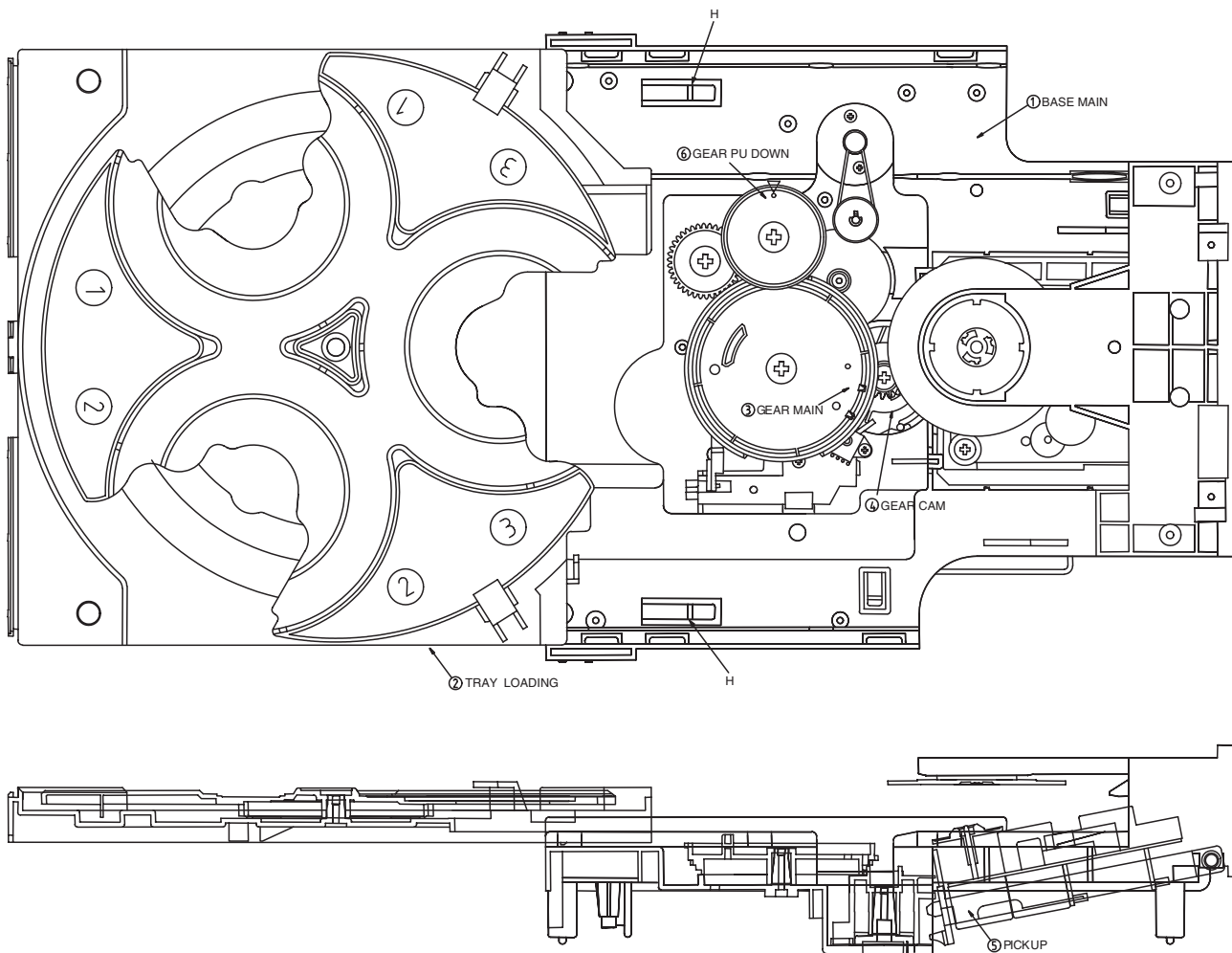

#### 1. How to open the tray

Push two hooks (H) of the BASE MAIN, and open the TRAY LOADING

#### 2. How to correct the distorted gears

(1) Turn GEAR MAIN until it clicks, if so that PICK-UP is downed completely

(2) The hold of GEAR FU DOWN array as the arrow of BASEMAIN

(3) Push the TRAY LOADING

# SCHEMATIC DIAGRAMS

## MPEG SCHEMATIC DIAGRAM

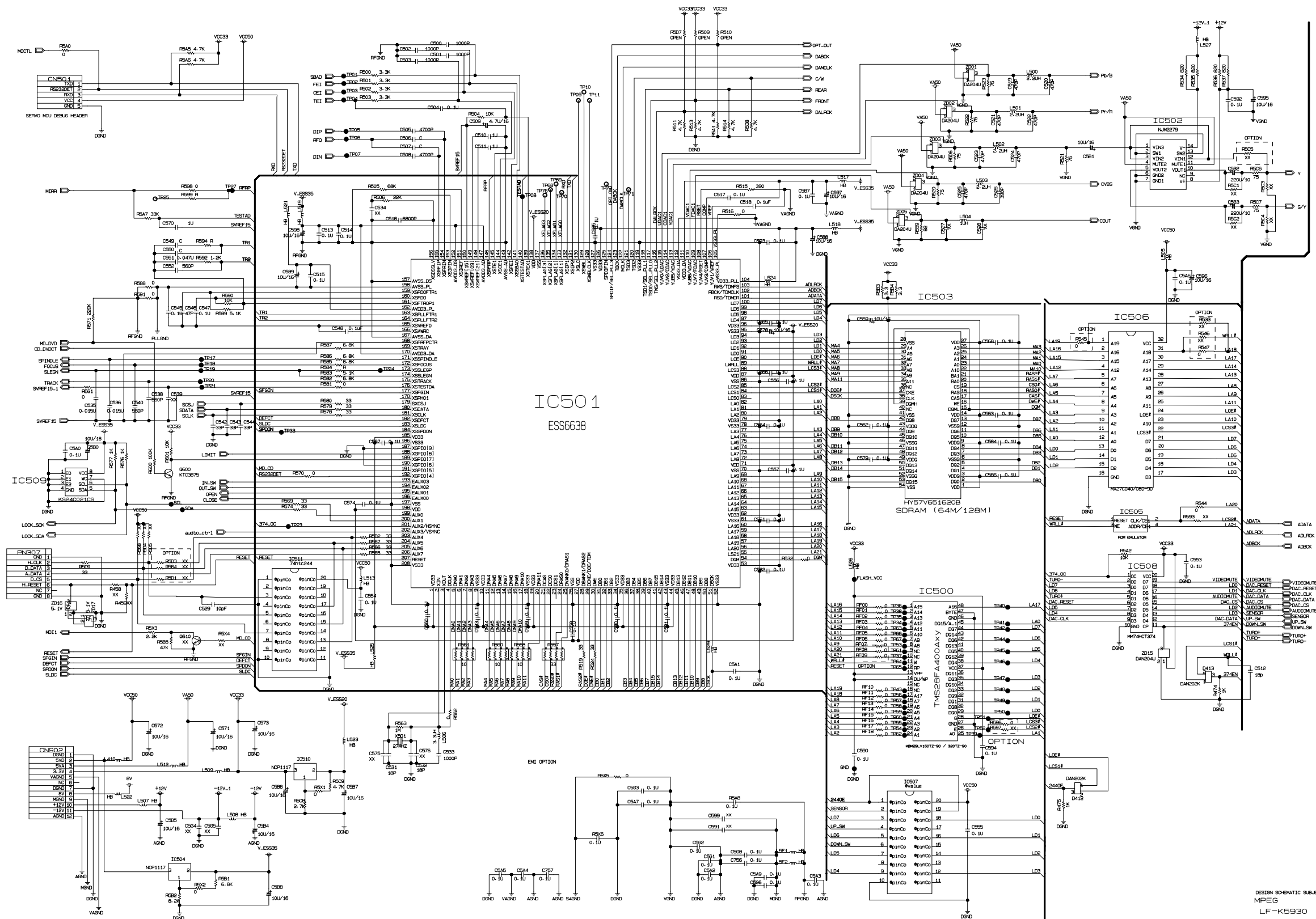

# • RF & SERVO SCHEMATIC DIAGRAM

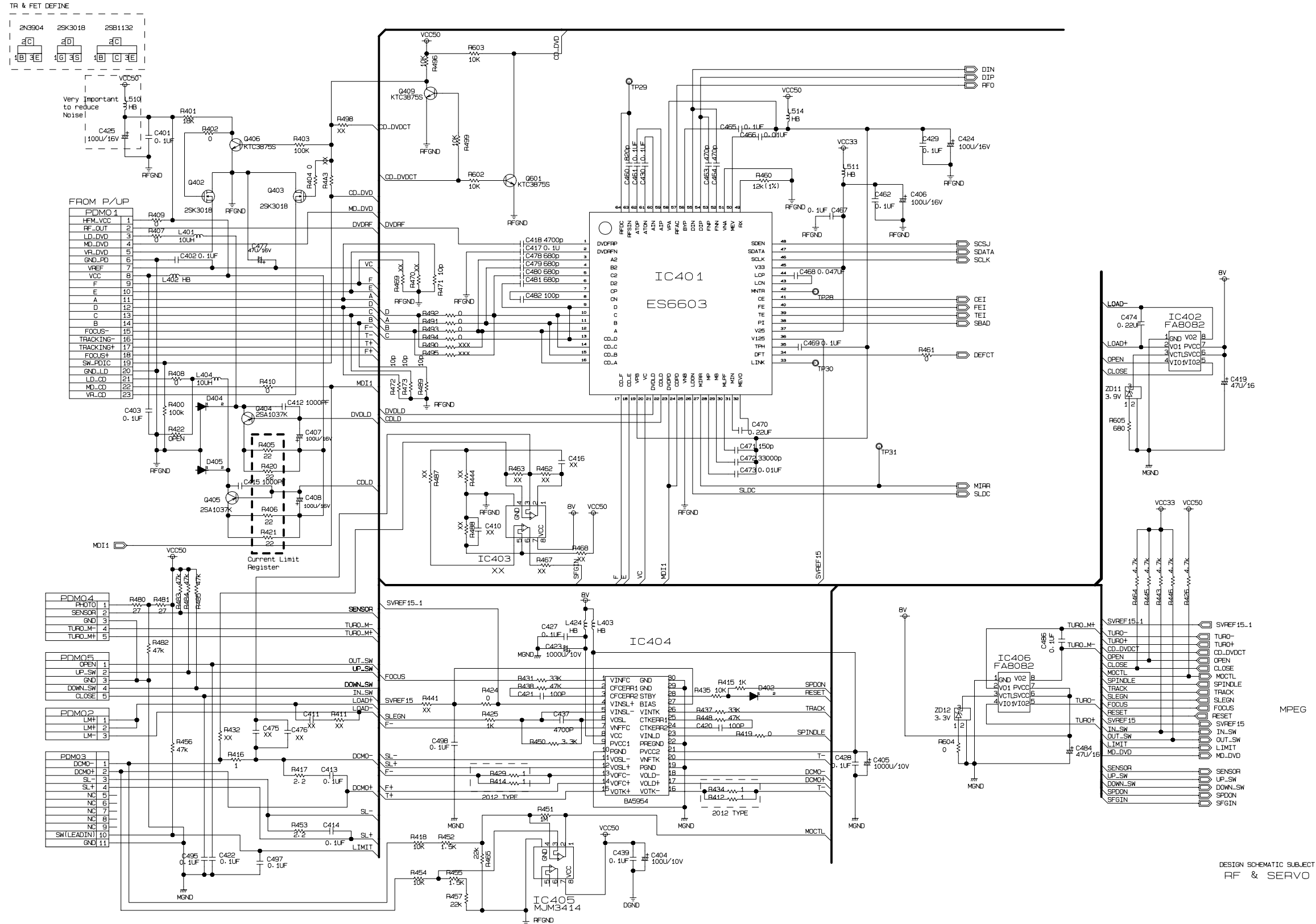

• I/O SCHEMATIC DIAGRAM

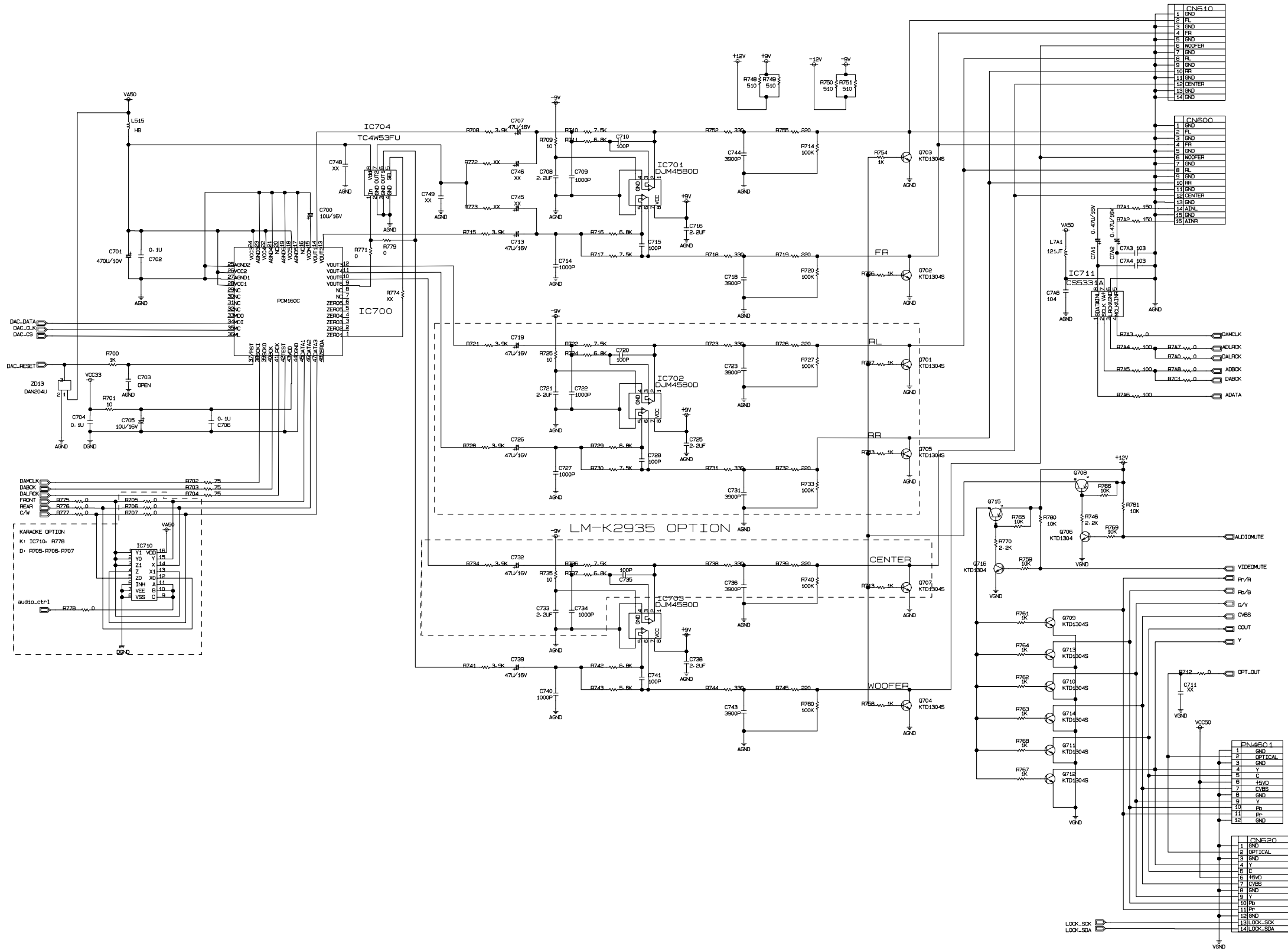

# PRINTED CIRCUIT DIAGRAMS

## MAIN P.C. BOARD (SOLDER SIDE)

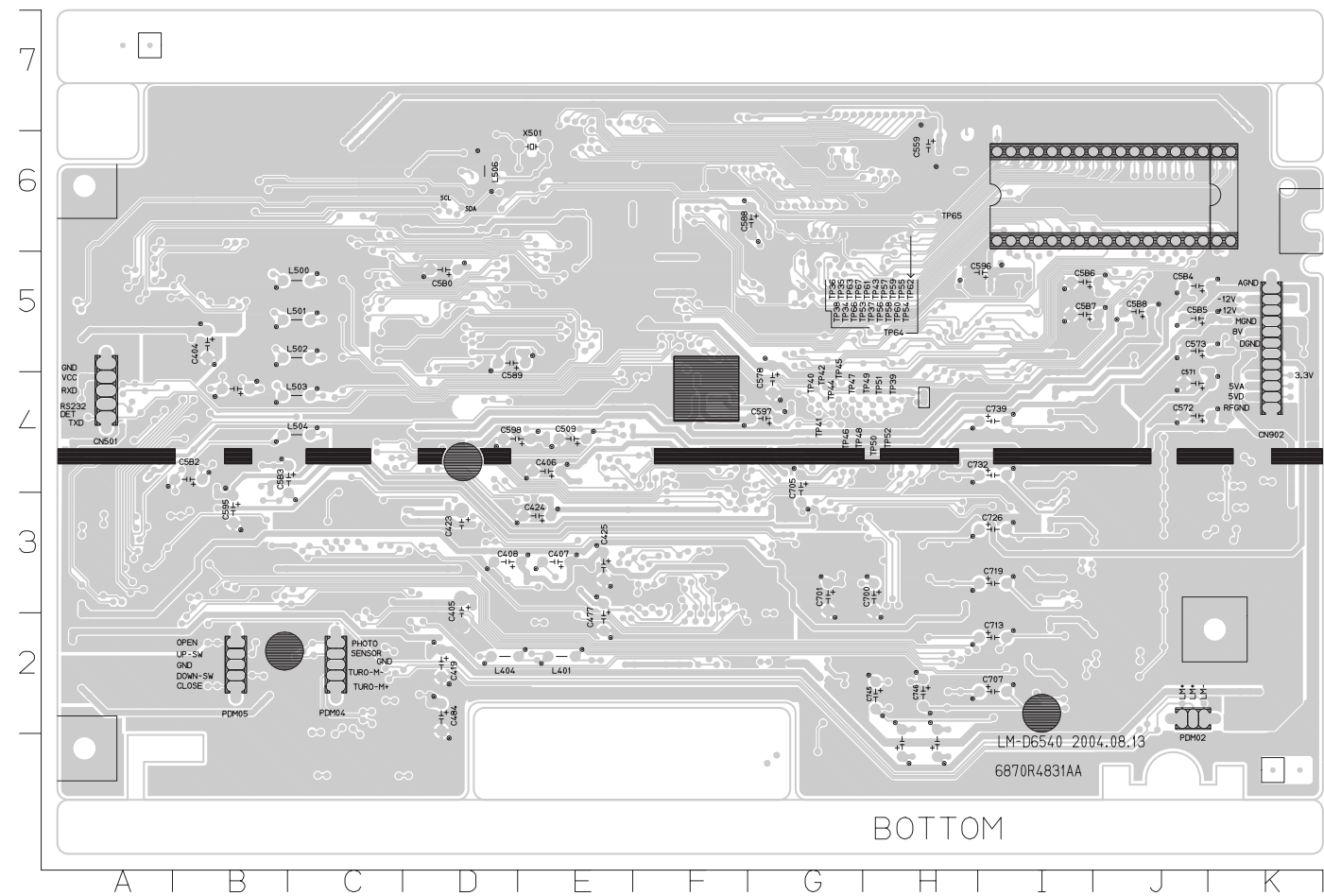

C401	G3	C479	F3	C543	H5	C593	F5	C718	B2	IC500	E5	L526	D4	R411	B2	R473	F3	R545	E5	R582	B5	R714	B2	R764	K3	TP03	F4
C402	F3	C480	F3	C544	H5	C594	E4	C719	C3	IC501	G5	L527	16	R412	H3	R474	C5	R546	C5	R583	D6	R715	D3	R765	J3	TP04	F4
C403	G2	C481	F3	C545	H5	C595	J3	C720	C3	IC502	J4	L529	F6	R414	H3	R475	D5	R547	C5	R584	D6	R716	C2	R766	J3	TP05	F4
C404	J5	C482	F3	C546	H5	C596	C5	C721	C3	IC503	E6	L5F1	F2	R415	13	R480	12	R557	G6	R585	E2	R717	C2	R767	K3	TP06	F3
C405	H3	C484	H2	C547	H5	C597	E4	C722	C3	IC504	B5	L5F2	H2	R416	11	R481	J2	R558	G6	R5C1	J4	R718	B2	R768	K3	TP07	F3
C406	G4	C486	12	C548	H5	C598	H4	C723	B3	IC505	A6	L7A1	E2	R417	11	R482	J2	R559	14	R5C2	J4	R719	B2	R769	K3	TP08	G4
C407	G3	C495	J2	C549	H5	C599	K2	C725	C3	IC506	C6	PDM01	F2	R418	J4	R483	J2	R560	G6	R5C3	J4	R720	B2	R770	J3	TP09	F4
C408	H3	C497	H1	C550	H5	C60A	H6	C726	C3	IC507	D5	PDM02	B2	R419	13	R484	J2	R561	G6	R5C4	J3	R721	D3	R771	D2	TP10	F4
C410	J3	C498	14	C551	H5	C6A1	F6	C727	C3	IC508	C5	PDM03	11	R420	G3	R485	J2	R562	G6	R5C5	J4	R722	B3	R772	D2	TP11	F4
C411	B2	C500	G4	C552	H5	C6A2	A4	C728	C3	IC509	H6	PDM04	12	R421	G3	R487	J3	R563	G6	R5C6	J4	R723	B3	R773	D2	TP17	H5
C412	G3	C501	G4	C553	C5	C6A3	E3	C731	B3	IC510	B5	PDM05	J2	R422	G2	R488	J3	R564	K5	R5C7	13	R724	C3	R774	D2	TP18	H5
C413	11	C502	G4	C554	J5	C6A4	E3	C732	C4	IC511	J5	PN307	K5	R424	13	R489	F3	R565	G6	R5C8	C5	R725	C3	R775	E4	TP19	H5
C414	12	C503	G4	C555	D5	C6A5	F4	C733	C4	IC700	E3	PN4601	K3	R425	14	R490	F3	R566	H6	R5C9	B5	R726	B3	R776	F4	TP20	H5
C415	H3	C504	G4	C556	F5	C6A6	C5	C734	C3	IC701	C2	Q402	F3	R426	K4	R491	F3	R567	G6	R5D1	K5	R727	B3	R777	F4	TP21	H5
C416	J2	C505	G4	C557	F5	C6A7	J6	C735	C4	IC702	C3	Q403	E3	R429	H3	R492	F3	R568	K5	R5D2	H6	R728	D3	R778	D5	TP23	C6
C417	F3	C506	H4	C558	G6	C6A8	K4	C736	B3	IC703	C4	Q404	G3	R431	13	R493	F3	R569	G6	R5D3	K6	R729	C3	R779	D2	TP24	G5
C418	F3	C507	H4	C559	D6	C6A9	K2	C738	C4	IC704	D2	Q405	H3	R432	J3	R494	F3	R570	H6	R5D4	K5	R730	C3	R780	J3	TP25	H5
C419	H2	C508	H4	C560	G6	C6B0	H5	C739	C4	IC710	D4	Q406	F3	R434	H3	R495	F3	R571	F2	R5D5	K5	R731	B3	R781	J3	TP27	H5
C420	13	C509	G4	C561	F6	C6B1	J4	C740	C4	IC711	D1	Q409	F3	R435	13	R496	E3	R574	G6	R5D6	15	R732	B3	R782	E4	TP28	F4
C421	13	C510	G4	C562	E6	C6B2	J4	C741	C4	L401	G2	Q600	H4	R437	13	R498	E3	R576	H6	R5D7	F4	R733	B3	R783	D1	TP29	F3
C422	J2	C511	G4	C563	E7	C6B3	14	C743	B4	L402	G2	Q601	E3	R438	13	R499	F3	R577	H6	R5D8	F4	R734	D3	R784	D1	TP30	G4
C423	H3	C512	C5	C564	F5	C6B4	B5	C744	B2	L403	H3	Q610	E2	R441	14	R4A3	E3	R578	H5	R5D9	K5	R735	C4	R7A3	E2	TP31	G3
C424	G3	C513	G4	C565	F5	C6B5	B5	C745	D2	L404	H2	Q701	B3	R443	J2	R500	G4	R579	H5	R5E1	H5	R736	C3	R7A4	E1	TP33	H5
C425	G3	C514	G4	C566	F5	C6B6	C5	C746	D2	L410	A4	Q702	B2	R444	J3	R501	G4	R580	H5	R5X1	C5	R737	C3	R7A5	E1	TP68	G4
C427	13	C515	G5	C567	H6	C6B7	C5	C748	E2	L424	H3	Q703	B2	R445	12	R502	G4	R581	H5	R5X2	B5	R738	B3	R7A6	E1	TP69	G4
C428	13	C516	H4	C568	D7	C6B8	B5	C749	D2	L500	15	Q704	B4	R446	J2	R503	G4	R582	H5	R5X3	E2	R739	B4	R7A7	E4	TP70	F4
C429	G3	C517	F4	C569	G6	C6C1	A6	C756	E1	L501	15	Q705	B3	R448	13	R504	G4	R583	H5	R5X4	E2	R740	B3	R7A8	E4	TP71	F5
C430	F3	C518	F4	C570	H5	C6C2	A6	C757	A2	L502	15	Q706	J3	R450	13	R505	G4	R584	H5	R5X5	K2	R741	D3	R7C1	E4	TP72	E1
C437	13	C519	15	C571	B4	C6C3	16	C7A1	D1	L503	14	Q707	B4	R451	J4	R506	H4	R585	H5	R5X6	K2	R742	C4	RF00	E6	TP73	F4
C439	J5	C520	J5	C572	B4	C6C4	B7	C7A2	D1	L504	14	Q708	J3	R452	J4	R509	F4	R586	G5	R600	H3	R743	C4	RF01	E6	TP74	E1
C460	F3	C521	15	C573	B5	C6C5	D7	C7A3	D1	L505	C5	Q709	K2	R453	12	R510	F4	R587	G5	R601	H4	R744	B4	RF02	E5	TP75	E2
C461	F3	C522	J5	C574	H6	C6C6	A5	C7A4	D1	L506	H6	Q710	K3	R454	K4	R511	F4	R588	H5	R602	E3	R745	B4	RF03	E5	TP76	G4
C462	F4	C523	15	C575	G7	C6C8	A4	C7A6	E2	L507	A5	Q711	K3	R455	K4	R513	F4	R589	H5	R603	E3	R746	J3	RF04	E5	X501	G6
C463	F3	C524	J5	C576	G7	C700	D3	CN501	K4	L508	A5	Q712	K3	R456	H1	R514	F4	R590	H5	R604	12	R748	C4	RF05	E5	ZD01	15
C464	F4	C525	14	C578	E4	C701	E3	CN600	A3	L509	A5	Q713	K3	R457	K4	R515	F4	R591	H5	R605	15	R749	C4	RF06	E5	ZD02	15
C465	F3	C526	J4	C579	E6	C702	E3	CN610	A3	L510	G3	Q714	K3	R458	16	R516	F4	R592	H5	R700	E4	R750	C4	RF07	E5	ZD03	15
C466	F4	C527	14	C580	F6	C703	E4	CN620	K3	L511	G4	Q715	J3	R459	16	R519	F7	R593	A5	R701	D4	R751	C4	RF08	E5	ZD04	14
C467	F4	C528	J4	C581	F6	C704	D4	CN902	A4	L512	A4	Q716	J3	R460	F4	R520	14	R594	H5	R702	E4	R752	B2	RF09	E5	ZD05	14
C468	F4	C529	K6	C582	F6	C705	E4	D402	13	L513	J5	R400	E3	R461	G4	R521	J5	R596	D4	R703	E4	R753	B3	RF10	E5	ZD11	12
C469	G4	C531	G7	C583	G6	C706	D4	D404	G2	L514	G3	R401	F3	R462	J2	R522	15	R597	D4	R704	E4	R754	B2	RF11	E5	ZD12	12
C470	G4	C532	G7	C584	E7	C707	C2	D405	H2	L515	E3	R402	F3	R463	J2	R523	15	R598	H5	R705	D4	R755	B2	RF12	E5	ZD13	E4
C471	G4	C533	H6	C585	F4	C708	C2	D412	D5	L517	E4	R403	E3	R464	H2	R524	F7	R599	H5	R706	D4	R756	B3	RF13	E5	ZD15	C5
C472	G4	C534	G4	C586	E7	C709	C2	D413	C5	L518	E6	R404	E3	R465	K4	R532	F6	R5A0	K4	R707	D3	R757	B3	RF14	E5	ZD16	K5
C473	G4	C535	H5	C587	F4	C710	C2	IC401	F3	L519	H4	R405	G3	R467	J3	R533	C7	R5A1	F4	R708	D3	R758	B4	RF15	E5	ZD17	K5
C474	12	C536	H5	C588	E6	C711	K4	IC402	12	L521	H4	R406	G3	R468	J3	R534	16	R5A2	C4	R709	C2	R759	J3	RF16	E5		
C475	J1	C538	H5	C589	H5	C713	C2	IC403	J3	L522	A5	R407	F3	R469	F3	R535	16	R5A5	K4	R710	B2	R760	B4	RF17	E5		
C476	J1	C539	H5	C590	D6	C714	C2	IC404	13	L523	C5																







## □ TAPE DECK MECHANISM (A/R & A/S : LEFT A/S DECK)

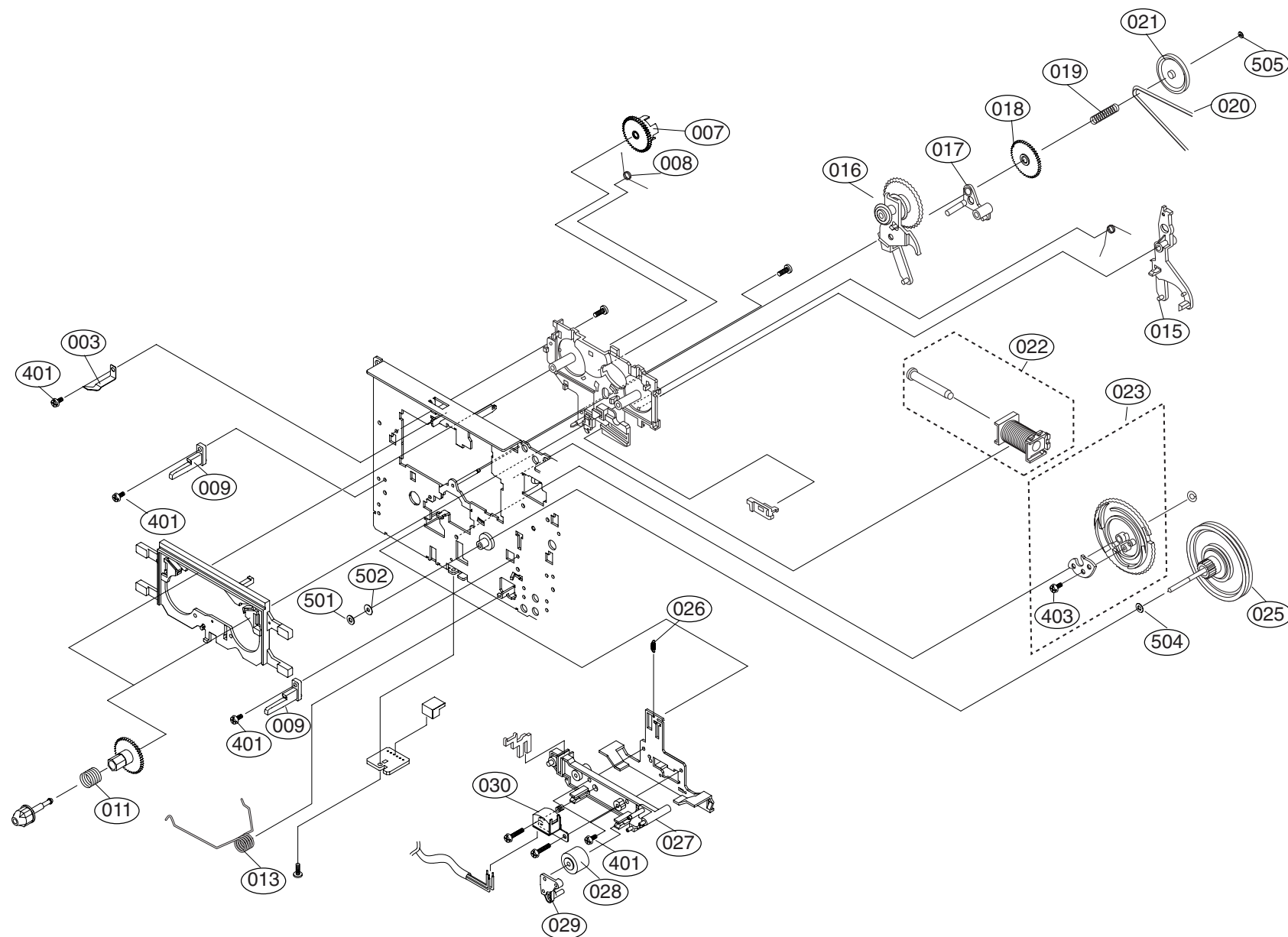

LOCA. NO.	LG PART NO.	DESCRIPTION	SPECIFICATION
A00	6720AG0002C	DECK,AUDIO	CWM42FR47 TOKYO PIGEON L-DOUBL
003	6768R-PP03A	DECK MECHANISM PARTS	33-160-4309 PIGEON PRESS CASSE
007	6768R-GP03B	DECK MECHANISM PARTS	50-222-4578 PIGEON GEAR IDLER
008	6768R-SP01F	DECK MECHANISM PARTS	01-082-4598 PIGEON SPRING CWL4
009	6768R-MP01C	DECK MECHANISM PARTS	50-219-4014 PIGEON MOLD CWL44
011	6768R-SP01A	DECK MECHANISM PARTS	01-081-4601 PIGEON SPRING CWL4
013	6768R-SP03A	DECK MECHANISM PARTS	01-082-4686 PIGEON SPRING CRM4
015	6768R-AP01A	DECK MECHANISM PARTS	50-268-3016 PIGEON ARM CWL44
016	6768R-GP01H	DECK MECHANISM PARTS	50-093-4503 PIGEON GEAR CRL442
017	6768R-AP01C	DECK MECHANISM PARTS	50-239-4072 PIGEON ARM CWL44
018	6768R-GP01J	DECK MECHANISM PARTS	50-222-4428 PIGEON GEAR CRL442
019	6768R-SP01P	DECK MECHANISM PARTS	01-081-4678 PIGEON SPRING CRL4
020	6768R-BP01C	DECK MECHANISM PARTS	02-083-4188 PIGEON BELT/FELT C
021	6768R-LP01C	DECK MECHANISM PARTS	50-223-4429 PIGEON PULLEY/FLYW
022	6768R-VP03A	DECK MECHANISM PARTS	50-093-4748 PIGEON SOLENOID AS
023	6768R-GP03A	DECK MECHANISM PARTS	50-093-4810 PIGEON GEAR ASSY C
025	6768R-JP03B	DECK MECHANISM PARTS	50-093-31009 PIGEON PULLEY/FLY
026	6768R-SP01D	DECK MECHANISM PARTS	01-080-4609 PIGEON SPRING CWL4
027	6768R-DP01A	DECK MECHANISM PARTS	50-259-3342 PIGEON LEVER CWL44
028	6768R-RP01A	DECK MECHANISM PARTS	22-027-41054 PIGEON ROLLER CWL
029	6768R-MP01A	DECK MECHANISM PARTS	50-219-4033 PIGEON MOLD CWL44
030	6768R-EP03C	DECK MECHANISM PARTS	T21V0P PIGEON HEAD CWM42FF30
401	6768R-CP01B	DECK MECHANISM PARTS	GSE20A2005 PIGEON SCREW CWL44
403	6768R-CP01D	DECK MECHANISM PARTS	GSL10A1704 PIGEON SCREW CWL44
501	6768R-WP03A	DECK MECHANISM PARTS	GWN19S035040 PIGEON WASHER CRM
502	6768R-WP03B	DECK MECHANISM PARTS	03-000-4532 PIGEON WASHER CRM4
504	6768R-WP01D	DECK MECHANISM PARTS	GWP21X045020 PIGEON WASHER CWL
505	6768R-WP01E	DECK MECHANISM PARTS	GWP12X030040S PIGEON WASHER CW

# □ TAPE DECK MECHANISM (A/R & A/S : RIGHT A/R DECK)

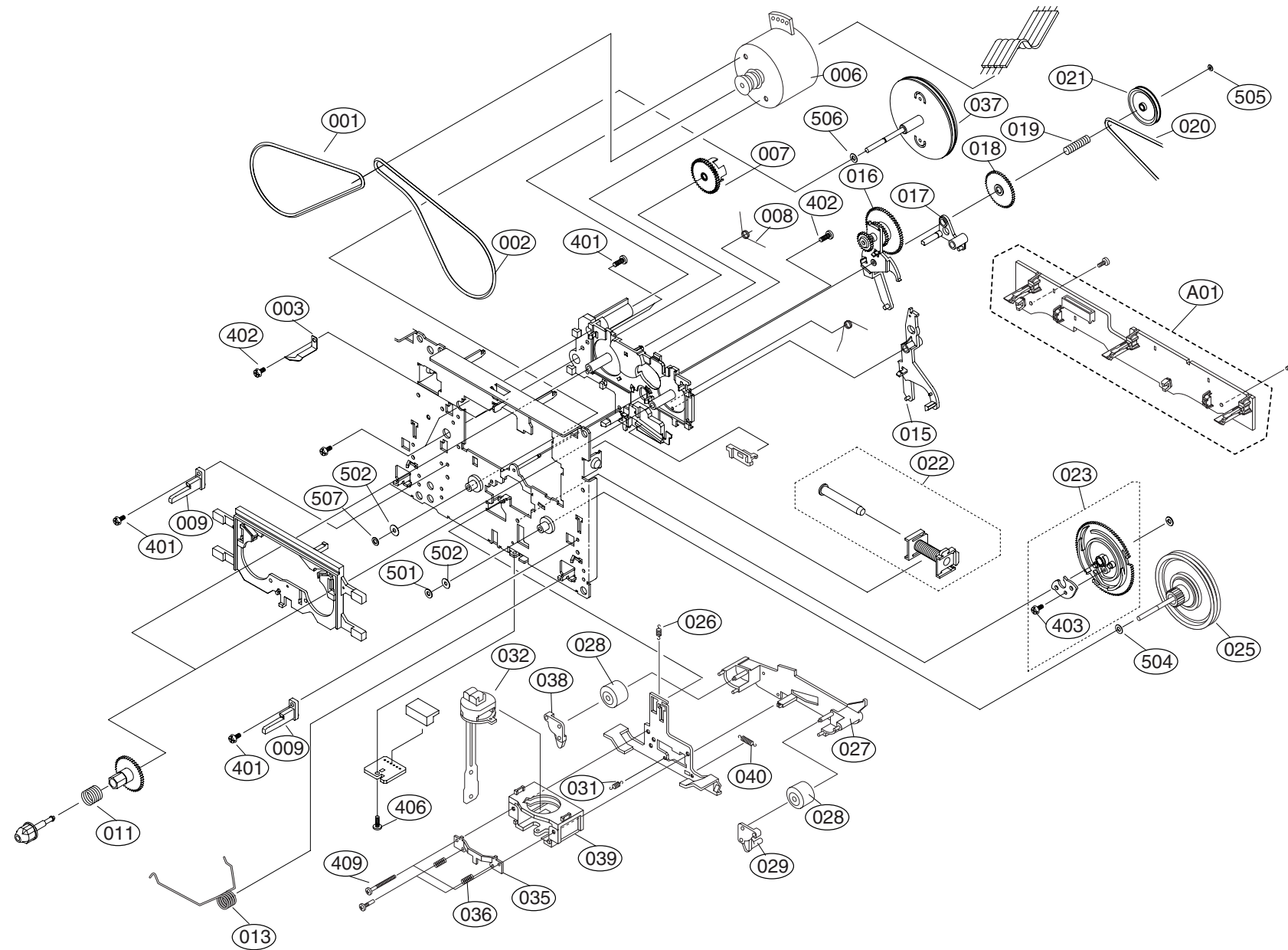

LOCA. NO.	LG PART NO.	DESCRIPTION	SPECIFICATION
A00	6720AG0002C	DECK,AUDIO	CWM42FR47 TOKYO PIGEON L-DOUBL
A01	6768R-UP03D	DECK MECHANISM PARTS	50-093-4895 PIGEON PWB UNIT CW
001	6768R-BP03D	DECK MECHANISM PARTS	02-083-4254 PIGEON BELT/FELT C
002	6768R-BP03E	DECK MECHANISM PARTS	02-083-4256 PIGEON BELT/FELT C
003	6768R-PP03A	DECK MECHANISM PARTS	33-160-4309 PIGEON PRESS CASSE
006	6768R-QP03C	DECK MECHANISM PARTS	50-093-4880 PIGEON MOTOR(ASSY)
007	6768R-GP03B	DECK MECHANISM PARTS	50-222-4578 PIGEON GEAR IDLER
008	6768R-SP01F	DECK MECHANISM PARTS	01-082-4598 PIGEON SPRING CWL4
009	6768R-MP01C	DECK MECHANISM PARTS	50-219-4014 PIGEON MOLD CWL44
011	6768R-SP01A	DECK MECHANISM PARTS	01-081-4601 PIGEON SPRING CWL4
013	6768R-SP03A	DECK MECHANISM PARTS	01-082-4686 PIGEON SPRING CRM4
015	6768R-AP01A	DECK MECHANISM PARTS	50-268-3016 PIGEON ARM CWL44
016	6768R-GP01H	DECK MECHANISM PARTS	50-093-4503 PIGEON GEAR CRL442
017	6768R-AP01C	DECK MECHANISM PARTS	50-239-4072 PIGEON ARM CWL44
018	6768R-GP01J	DECK MECHANISM PARTS	50-222-4428 PIGEON GEAR CRL442
019	6768R-SP01P	DECK MECHANISM PARTS	01-081-4678 PIGEON SPRING CRL4
020	6768R-BP01C	DECK MECHANISM PARTS	02-083-4188 PIGEON BELT/FELT C
021	6768R-LP01C	DECK MECHANISM PARTS	50-223-4429 PIGEON PULLEY/FLYW
022	6768R-VP03A	DECK MECHANISM PARTS	50-093-4748 PIGEON SOLENOID AS
023	6768R-GP03A	DECK MECHANISM PARTS	50-093-4810 PIGEON GEAR ASSY C
025	6768R-JP03B	DECK MECHANISM PARTS	50-093-31009 PIGEON PULLEY/FLY
026	6768R-SP01D	DECK MECHANISM PARTS	01-080-4609 PIGEON SPRING CWL4
027	6768R-DP01A	DECK MECHANISM PARTS	50-259-3342 PIGEON LEVER CWL44
028	6768R-RP01A	DECK MECHANISM PARTS	22-027-41054 PIGEON ROLLER CWL
029	6768R-MP01A	DECK MECHANISM PARTS	50-219-4033 PIGEON MOLD CWL44
031	6768R-SP04A	DECK MECHANISM PARTS	01-082-4731 PIGEON SPRING
032	6768R-EP04A	DECK MECHANISM PARTS	50-093-41007 PIGEON HEAD ASSY
035	6768R-PP04A	DECK MECHANISM PARTS	50-119-4915 PIGEON PRESS
036	6768R-SP04B	DECK MECHANISM PARTS	01-081-4730 PIGEON SPRING
037	6768R-JP03A	DECK MECHANISM PARTS	50-093-4674 PIGEON PULLEY/FLYW
038	6768R-MP01D	DECK MECHANISM PARTS	50-219-4034 PIGEON MOLD CWL44
039	6768R-MP02A	DECK MECHANISM PARTS	50-219-3900 PIGEON MOLD
040	6768R-SP01M	DECK MECHANISM PARTS	01-080-4607 PIGEON SPRING CWL4
401	6768R-CP01B	DECK MECHANISM PARTS	GSE20A2005 PIGEON SCREW CWL44
402	6768R-CP01A	DECK MECHANISM PARTS	GSE10A2003 PIGEON SCREW CWL44
403	6768R-CP01D	DECK MECHANISM PARTS	GSL10A1704 PIGEON SCREW CWL44
406	6768R-CP01G	DECK MECHANISM PARTS	GSE20A2004 PIGEON SCREW CWL44
409	6768R-CP02A	DECK MECHANISM PARTS	GSD10A2016 PIGEON SCREW
501	6768R-WP03A	DECK MECHANISM PARTS	GWN19S035040 PIGEON WASHER CRM
502	6768R-WP03B	DECK MECHANISM PARTS	03-000-4532 PIGEON WASHER CRM4
504	6768R-WP01D	DECK MECHANISM PARTS	GWP21X045020 PIGEON WASHER CWL
505	6768R-WP01E	DECK MECHANISM PARTS	GWP12X030040S PIGEON WASHER CW
506	6768R-WP01H	DECK MECHANISM PARTS	GWP23X040020 PIGEON WASHER CWL
507	6768R-WP01F	DECK MECHANISM PARTS	GWN21X040040 PIGEON WASHER CWL

## □ DECK MECHANISM EXPLODED VIEWS

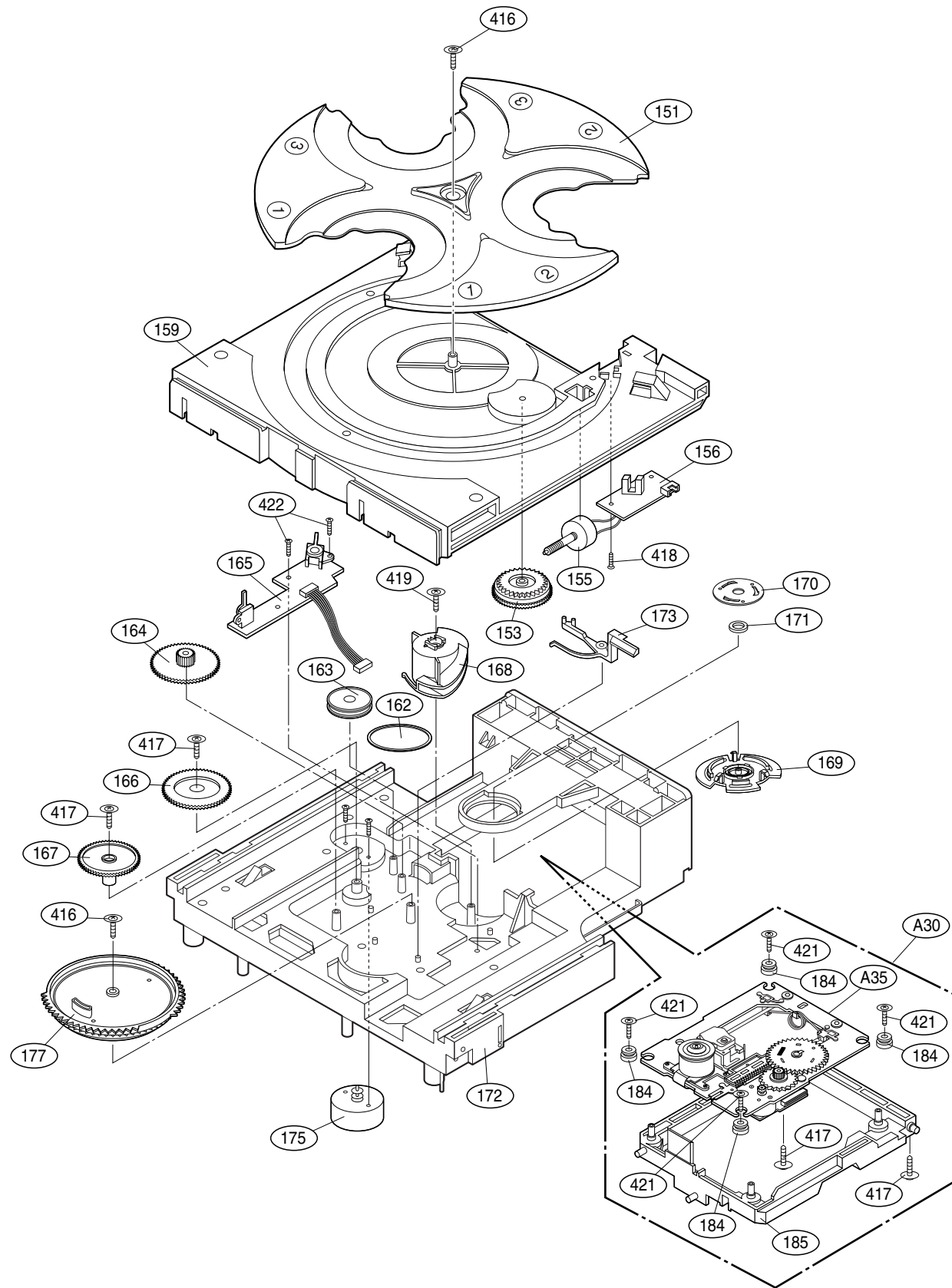

LOCA.NO	PART NO	DESCRIPTION	SPECIFICATION
A26	4405RCS006E	MECHANISM ASSEMBLY	DVM-H1513 HZ(DP-8-VE)DVD 3
A30	3041RBD003C	BASE ASSEMBLY	PU (DVM-H1513 DP-8-VE) HZ
A35	3041R-M016L	BASE ASSEMBLY	SLED(DP-8-VE) HZ
151	3390RB0002A	TRAY	DISC(CDM-H1503)
153	4470RB0005A	GEAR	TRAY (CDM-H1503)
155	4681RBA001B	MOTOR ASSEMBLY	HOME TRAY (CDM-H1503) MABUCHI
156	6871RF9211A	PWB(PCB) ASSEMBLY,FRONT	1503 T/D SENSOR
159	3390RB0001A	TRAY	LOADING(CDM-H1503)
162	4400SB0001A	BELT	AUDIO MAIN(CDM-H1303)
163	4470SB0003A	GEAR	PULLEY (CDM-H1303)
164	4470RB0003A	GEAR	LOADING (CDM-H1503)
165	6871RZ7036A	PWB(PCB) ASSEMBLY,OTHERS	CDM-H1503 UP/DW/OP/CL
166	4470RB0006A	GEAR	PU UP (CDM-H1503)
167	4470RB0007A	GEAR	PU DOWN (CDM-H1503)
168	4470RB0002A	GEAR	CAM (CDM-H1503)
170	3300R-0547A	PLATE	CLAMP
171	5016H-1016B	MAGNET	CLAMP(LDM-R608,10*5,1*1.5T)"
172	3040RB0005A	BASE	MAIN (CDM-H1503)
173	4510RB0001A	LEVER	S/W CLOSE
175	4680SBP001A	MOTOR(MECH)	OTHER . . .
177	4470RB0001A	GEAR	MAIN (CDM-H1503)
184	5040R-0075D	RUBBER	DAMPER DP7 (YAMAUCHI 30)
185	3040RBM001A	BASE	PU MOLD (DVM-H1513)
416	88H-0004	CD MECHA PARTS	3X12X12FNM
417	88H-0002	CD MECHA PARTS	3X9X12FZMY
418	353-025BAAA	SCREW,DRAWING	#NAME?
419	88H-0003	CD MECHA PARTS	3X12X10FZMY
420	353S353F	SCREW,DRAWING	#NAME?
421	1SZZH-1003A	SCREW,DRAWING	+ D2.0 6MM SWRCH16A/NIY 4.5MM
422	353-028H	SCREW	#NAME?



# SECTION 5. SPEAKER PART

□ MODEL : LMS-D2540V

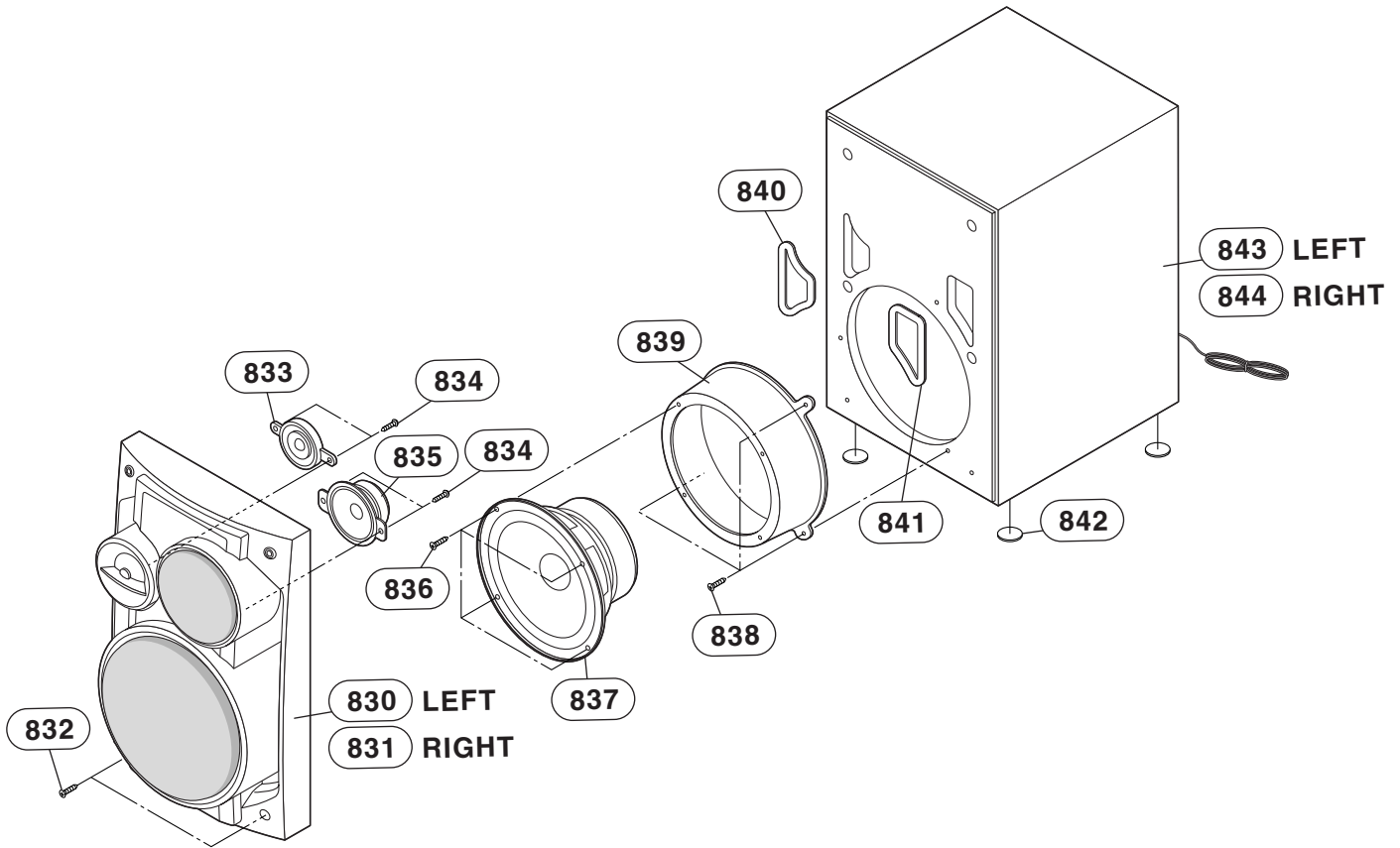

LOCA.NO.	PART NO	DESCRIPTION	SPECIFICATION	REMARKS
830	3720RMF106A	PANEL,FRONT	SPK LMS-D6540V MOLD FRONT PANE	
831	3720RMF107A	PANEL,FRONT	SPK LMS-D6540V MOLD RIGHT FRON	
832	353M050C	SCREW,DRAWING	BH 3.5X16 FBK	
833	6400RMXY01A	SPEAKER,GENERAL	(FE-376E) PIEZO LG 0OHM 0W 0DB	
834	353M025F	SCREW,DRAWING	TAPTITE, 3X8 FZMY	
835	6400TSMA02A	SPEAKER,TWEETER	CTR-50B55L SAMMI TWEETER(CONE)	
836	353M050M	SCREW,DRAWING	+ 2 D3.5 L10.0 MSWR3/FZY	
837	6400WSMJ07A	SPEAKER,WOOFER	CW-165B55L SAMMI WOOFER 6OHM 5	
839	4350RM0013A	RING	SPK LMS-D6540V MOLD WOOFER RIN	
840	4766RM0158A	FELT	LMS-D6540V BLACK FOR DUCT1	
841	4766RM0159A	FELT	LMS-D6540V BLACK FOR DUCT2	
842	3610RM0051A	FOOT	SPK LFS-K5930V OTHER PHI 20 X	
843	3091RMW125A	CABINET ASSEMBLY	SPK LMS-D6540V CABINET ASSY	
844	3091RMW125B	CABINET ASSEMBLY	SPK LMS-D6540V RIGHT CABINET A	

