

SERVICE MANUAL MODEL: LM-U1050A,LMS-U1050

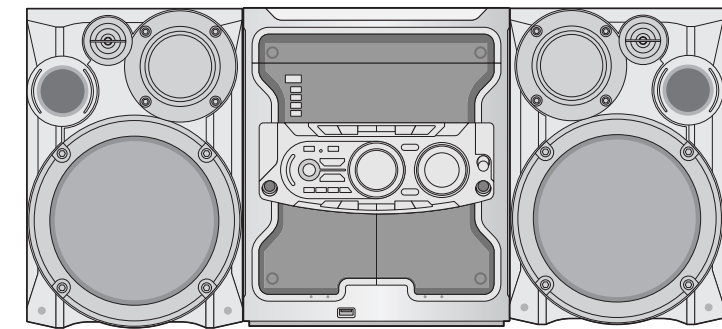

3CD CHANGER DVD KARAOKE SYSTEM **SERVICE MANUAL**



MODEL: LM-U1050A,LMS-U1050

[CONTENTS]

○ SECTION 1. GENERAL

- SERVICING PRECAUTIONS 1-2
- ESD PRECAUTIONS 1-4
- SPECIFICATIONS 1-5

○ SECTION 2. ELECTRICAL SECTION

- TROUBLESHOOTING GUIDE 2-1
- AUDIO PART TROUBLESHOOTING 2-3
- BLOCK DIAGRAM 2-27
- SCHEMATIC DIAGRAMS 2-28
- WIREING DIAGRAM 2-43
- PRINTED CIRCUIT DIAGRAMS 2-45

○ SECTION 3. EXPLODED VIEWS

- CABINET AND MAIN FRAME SECTION 3-1
- TAPE DECK MECHANISM (A/R & A/S : RIGHT A/R DECK) 3-3
- TAPE DECK MECHANISM (A/R & A/S : LEFT A/S DECK) 3-5
- CD MECHANISM 3-7

○ SECTION 4. SPEAKER PART

- SPEAKER PART 4-1

○ SECTION 5. REPLACEMENT PARTS LIST

- REPLACEMENT PARTS LIST 5-1

SECTION 1. GENERAL

SERVICING PRECAUTIONS

NOTES REGARDING HANDLING OF THE PICK-UP

1. Notes for transport and storage

- 1) The pick-up should always be left in its conductive bag until immediately prior to use.
- 2) The pick-up should never be subjected to external pressure or impact.

Storage in conductive bag

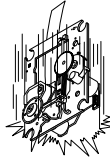
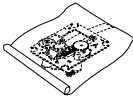

Drop impact

2. Repair notes

- 1) The pick-up incorporates a strong magnet, and so should never be brought close to magnetic materials.
- 2) The pick-up should always be handled correctly and carefully, taking care to avoid external pressure and impact. If it is subjected to strong pressure or impact, the result may be an operational malfunction and/or damage to the printed-circuit board.
- 3) Each and every pick-up is already individually adjusted to a high degree of precision, and for that reason the adjustment point and installation screws should absolutely never be touched.
- 4) Laser beams may damage the eyes!
Absolutely never permit laser beams to enter the eyes!
Also NEVER switch ON the power to the laser output part (lens, etc.) of the pick-up if it is damaged.

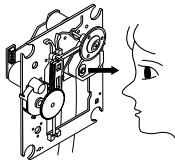

NEVER look directly at the laser beam, and don't let contact fingers or other exposed skin.

5) Cleaning the lens surface

If there is dust on the lens surface, the dust should be cleaned away by using an air bush (such as used for camera lens). The lens is held by a delicate spring. When cleaning the lens surface, therefore, a cotton swab should be used, taking care not to distort this.

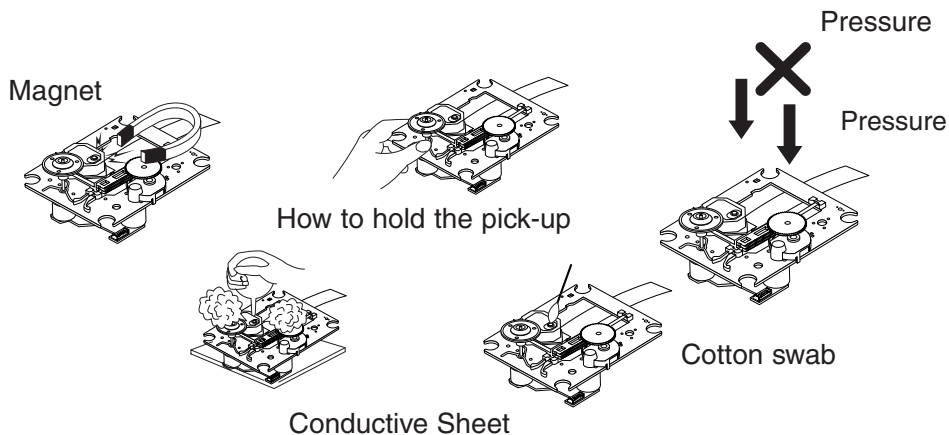

6) Never attempt to disassemble the pick-up.

Spring by excess pressure. If the lens is extremely dirty, apply isopropyl alcohol to the cotton swab. (Do not use any other liquid cleaners, because they will damage the lens.) Take care not to use too much of this alcohol on the swab, and do not allow the alcohol to get inside the pick-up.

• NOTES REGARDING COMPACT DISC PLAYER REPAIRS

1. Preparations

- 1) Compact disc players incorporate a great many ICs as well as the pick-up (laser diode). These components are sensitive to, and easily affected by, static electricity. If such static electricity is high voltage, components can be damaged, and for that reason components should be handled with care.
- 2) The pick-up is composed of many optical components and other high-precision components. Care must be taken, therefore, to avoid repair or storage where the temperature or humidity is high, where strong magnetism is present, or where there is excessive dust.

2. Notes for repair

- 1) Before replacing a component part, first disconnect the power supply lead wire from the unit
- 2) All equipment, measuring instruments and tools must be grounded.
- 3) The workbench should be covered with a conductive sheet and grounded.
When removing the laser pick-up from its conductive bag, do not place the pick-up on the bag. (This is because there is the possibility of damage by static electricity.)
- 4) To prevent AC leakage, the metal part of the soldering iron should be grounded.
- 5) Workers should be grounded by an armband (1M Ω)
- 6) Care should be taken not to permit the laser pick-up to come in contact with clothing, in order to prevent static electricity changes in the clothing to escape from the armband.
- 7) The laser beam from the pick-up should NEVER be directly facing the eyes or bare skin.

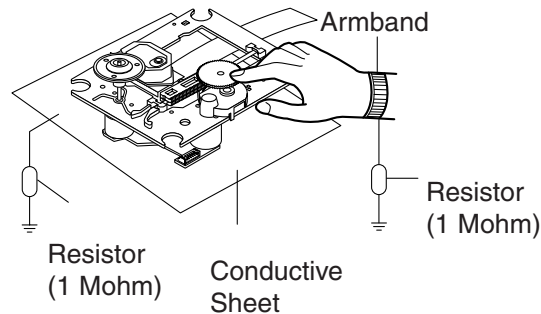

CLEARING MALFUNCTION

You can reset your unit to initial status if malfunction occur(button malfunction, display, etc.).

Using a pointed good conductor(such as driver), simply short the RESET jump wire on the inside of the volume knob for more than 3 seconds.

If you reset your unit, you must reenter all its settings(stations, clock, timer)

NOTE: 1. To operate the RESET jump wire, pull the volume rotary knob and release it.

2. If you wish to operate the RESET jump wire, it is necessary to unplug the power cord.

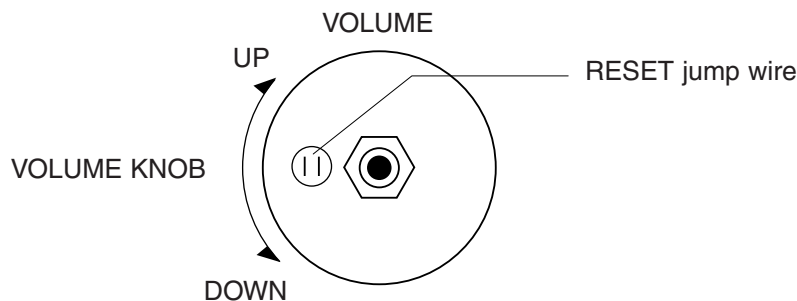

□ ESD PRECAUTIONS

• Electrostatically Sensitive Devices (ESD)



Some semiconductor (solid state) devices can be damaged easily by static electricity. Such components commonly are called Electrostatically Sensitive Devices (ESD). Examples of typical ESD devices are integrated circuits and some field-effect transistors and semiconductor chip components. The following techniques should be used to help reduce the incidence of component damage caused by static electricity.

1. Immediately before handling any semiconductor component or semiconductor-equipped assembly, drain off any electrostatic charge on your body by touching a known earth ground. Alternatively, obtain and wear a commercially available discharging wrist strap device, which should be removed for potential shock reasons prior to applying power to the unit under test.
2. After removing an electrical assembly equipped with ESD devices, place the assembly on a conductive surface such as aluminum foil, to prevent electrostatic charge buildup or exposure of the assembly.
3. Use only a grounded-tip soldering iron to solder or unsolder ESD devices.
4. Use only an anti-static solder removal device. Some solder removal devices not classified as "anti-static" can generate electrical charges sufficient to damage ESD devices.
5. Do not use freon-propelled chemicals. These can generate electrical charges sufficient to damage ESD devices.
6. Do not remove a replacement ESD device from its protective package until immediately before you are ready to install it. (Most replacement ESD devices are packaged with leads electrically shorted together by conductive foam, aluminum foil or comparable conductive materials).
7. Immediately before removing the protective material from the leads of a replacement ESD device, touch the protective material to the chassis or circuit assembly into which the device will be installed.

CAUTION : BE SURE NO POWER IS APPLIED TO THE CHASSIS OR CIRCUIT, AND OBSERVE ALL OTHER SAFETY PRECAUTIONS.

8. Minimize bodily motions when handling unpackaged replacement ESD devices. (Otherwise harmless motion such as the brushing together of your clothes fabric or the lifting of your foot from a carpeted floor can generate static electricity sufficient to damage an ESD device).

• CAUTION. GRAPHIC SYMBOLS

	THE LIGHTNING FLASH WITH APROWHEAD SYMBOL. WITHIN AN EQUILATERAL TRIANGLE, IS INTENDED TO ALERT THE SERVICE PERSONNEL TO THE PRESENCE OF UNINSULATED "DANGEROUS VOLTAGE" THAT MAY BE OF SUFFICIENT MAGNITUDE TO CONSTITUTE A RISK OF ELECTRIC SHOCK.
	THE EXCLAMATION POINT WITHIN AN EQUILATERAL TRIANGLE IS INTENDED TO ALERT THE SERVICE PERSONNEL TO THE PRESENCE OF IMPORTANT SAFETY INFORMATION IN SERVICE LITERATURE.

□ SPECIFICATIONS

[General]	Power supply	Refer to the back panel.	
	Power consumption	50 W	
	Mass	6.3kg	
	External dimensions (W x H x D)	273 x 326 x 366 mm	
[CD]	Laser	Semiconductor laser, wavelength 650 nm	
	Frequency response (audio)	40 - 18000 Hz	
	Signal-to-noise ratio (audio)	More than 70 dB (1 kHz)	
	Dynamic range (audio)	More than 70 dB	
	Harmonic distortion (audio)	0.7 % (1 kHz)	
[Tuner]	FM	Tuning Range	87.5-108.0MHz / 65-74MHz, 87.5-108.0MHz
		Intermediate Frequency	10.7 MHz
		Signal to Noise Ratio (Mono/Stereo)	60/55 dB
		Frequency Response	60 - 10000 Hz
	AM (MW)	Tuning Range	522 - 1620 kHz or 520 - 1720 kHz
		Intermediate Frequency	450 kHz
		Signal to Noise Ratio	35 dB
		Frequency Response	120-2000Hz
[Amplifier]	output Power	100x100 (4Ω/2ch THD, 10%)	
	T.H.D	0.5%	
	Frequency Response	42Hz - 2000KHz	
	Signal-to-noise ratio	75 dB	
[Speaker]	Type	3 Way 3 Speaker	
	Impedance	4Ω	
	Frequency Response	55 - 20000 Hz	
	Sound Pressure Level	85 dB/W (1m)	
	Rated Input Power	100 W	
	Max. Input Power	200 W	
	Net Dimensions (W x H x D)	227 x 327 x 272 mm	
	Net Weight	4.2kg	
TAPE	Tape Speed	4.75 cm/sec	
	Wow Flutter	0.25% (MTT -111, JIS-WTD)	
	F.F/REW. Time	120sec (C-60)	
	Frequency Response	125-8000Hz	
	Signal to Noise Ratio	40dB	
	Channel Separation	50dB(P/B)/45dB(R/P)	
	Erase Ratio	55dB (MTT-5511)	

NOTE : Specification are subject to change without notice in the course of product improvement.

SECTION 2. ELECTRICAL

TROUBLESHOOTING GUIDE

P-SENS PART CHECK

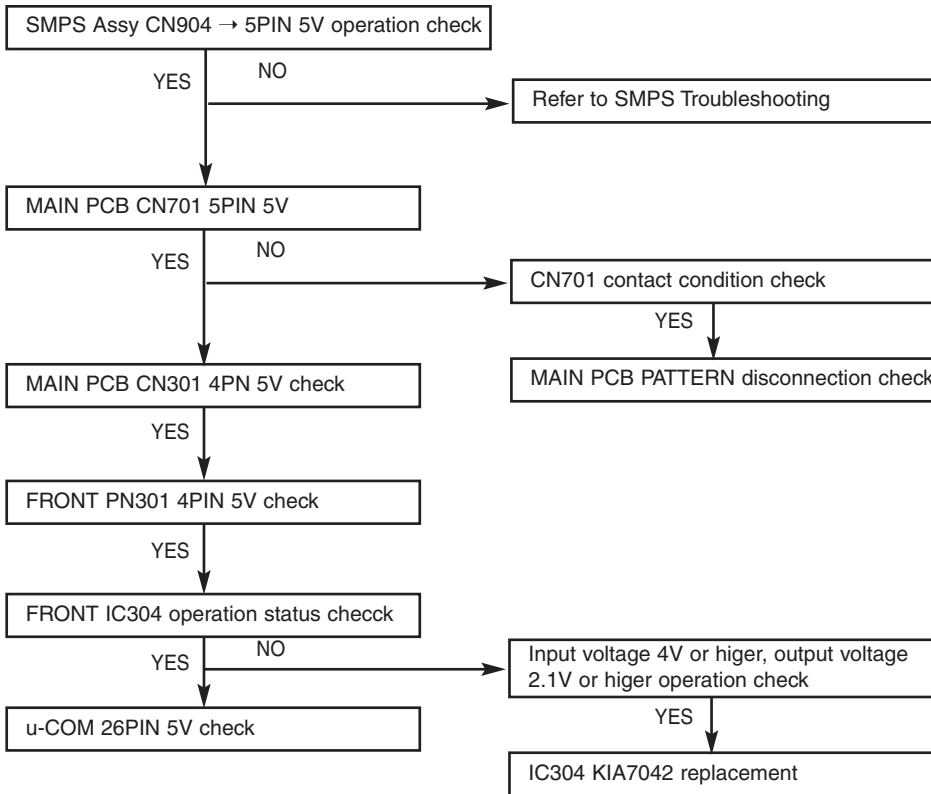

VKK CHECK

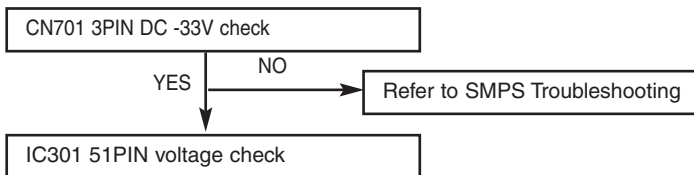

Muting circuit Troublrshooting (MUTE condition)

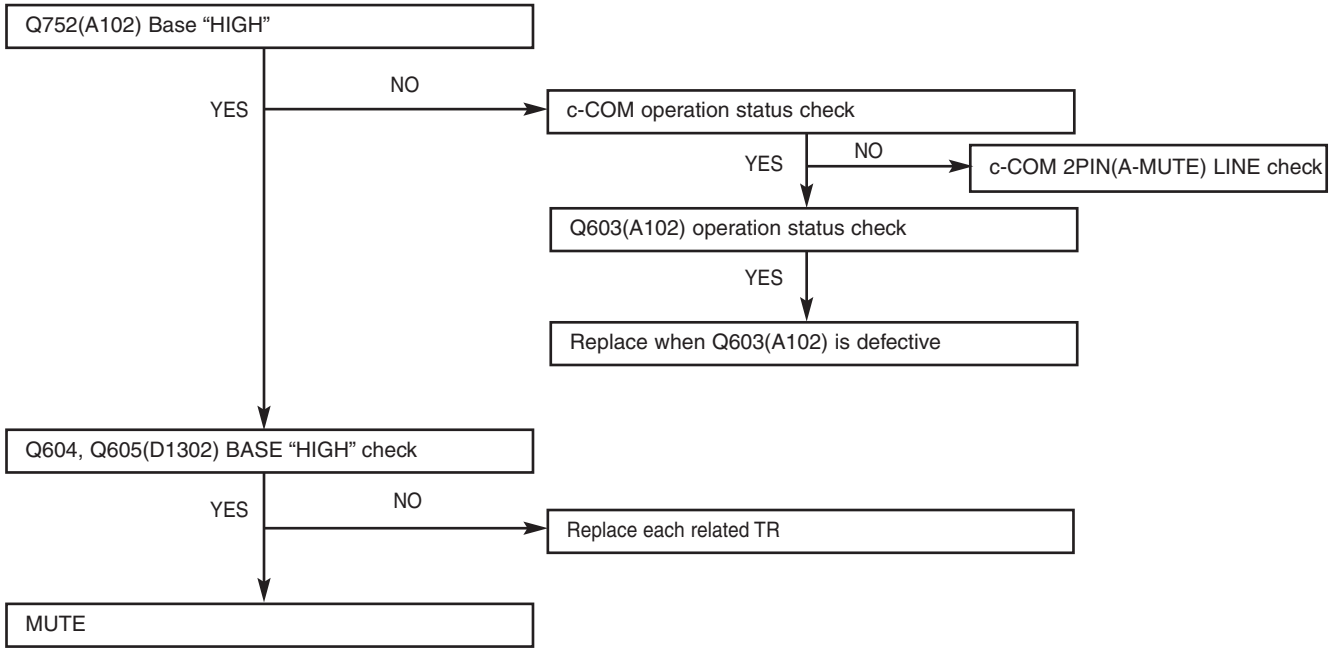

Unfelt voice

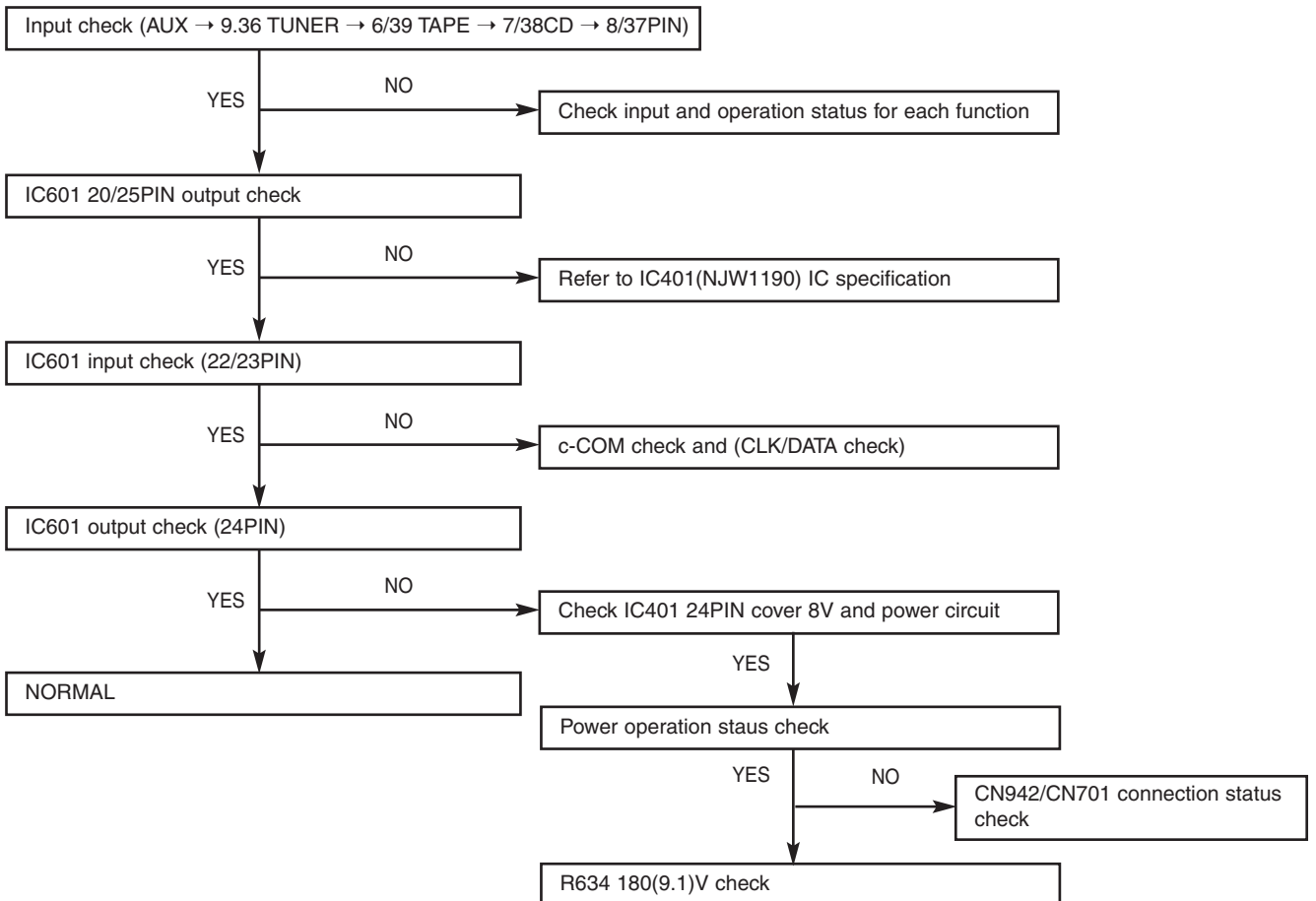

Specific FUNCTION MODE unfelt voice

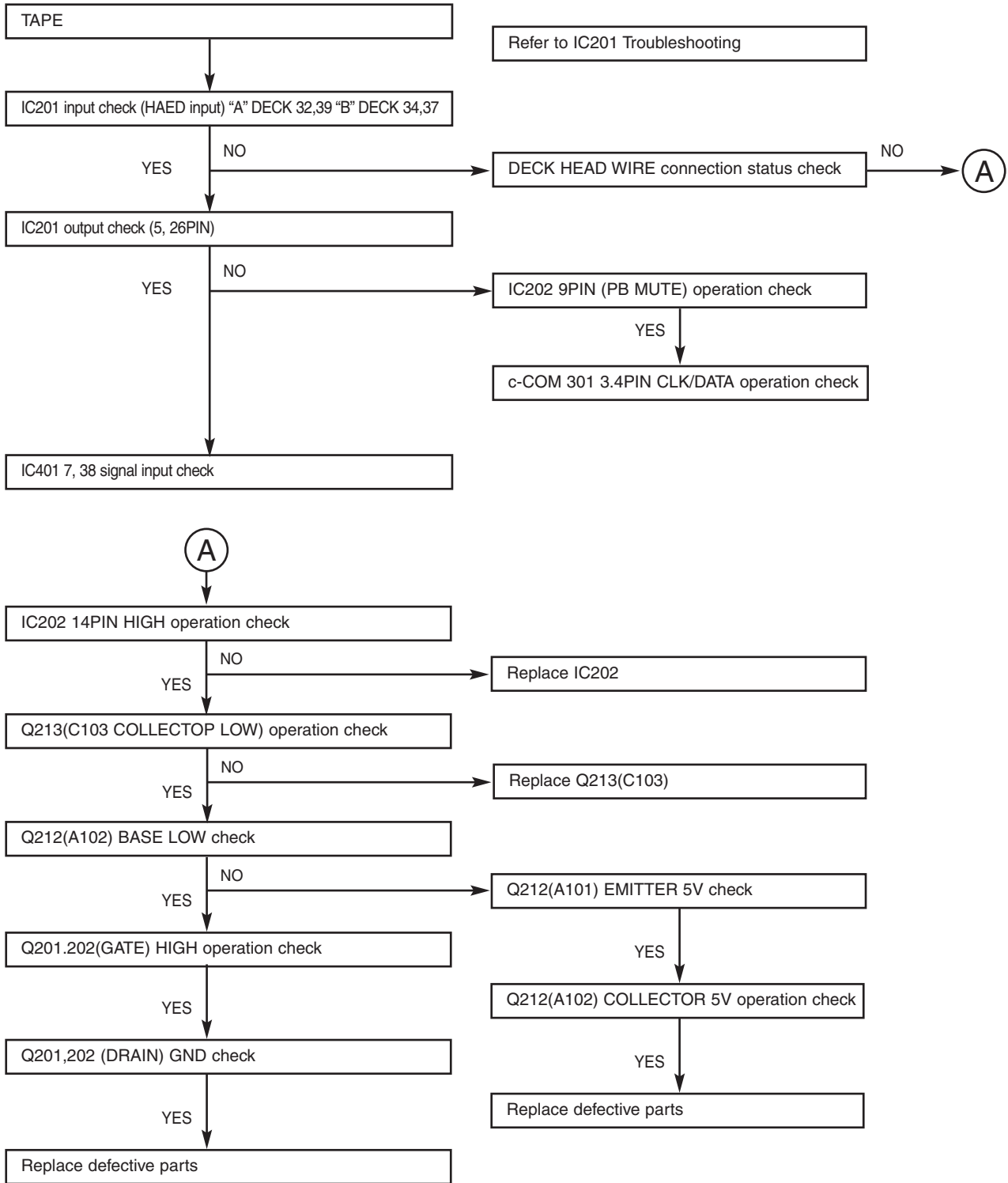

AUX

YES

JK601 signal input check

YES

IC401 9,36PIN signal input check

CD

YES

Check Cn601 1,3PIN signal anad Refer to CD Troubleshooting

YES

NO

MAIN PCB PATTERN check

IC601 8,3PIN signal input check

TUNER

YES

Refer to TUNERMODULE

YES

IC401 6,39PIN signal input check

MIC

YES

IC401 1PIN input check

YES

Refer to IC404 Toubleshooting

(B)

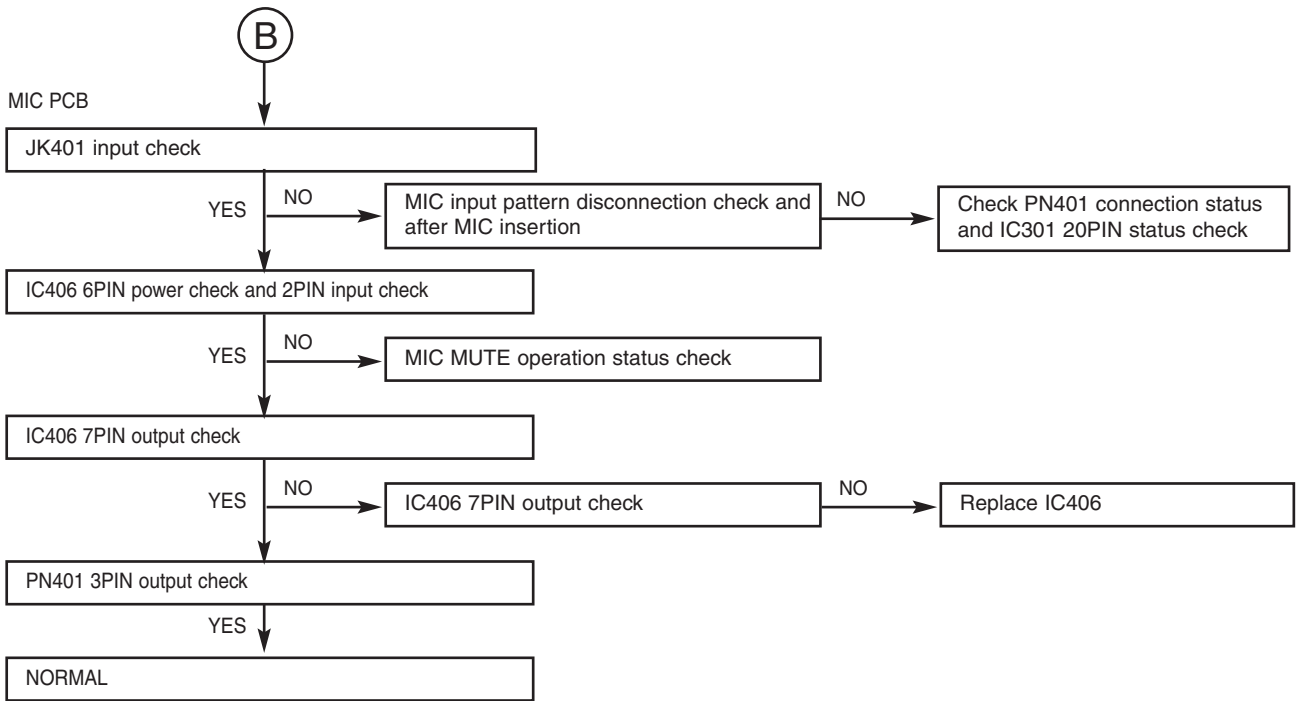

IC301 Troubleshooting

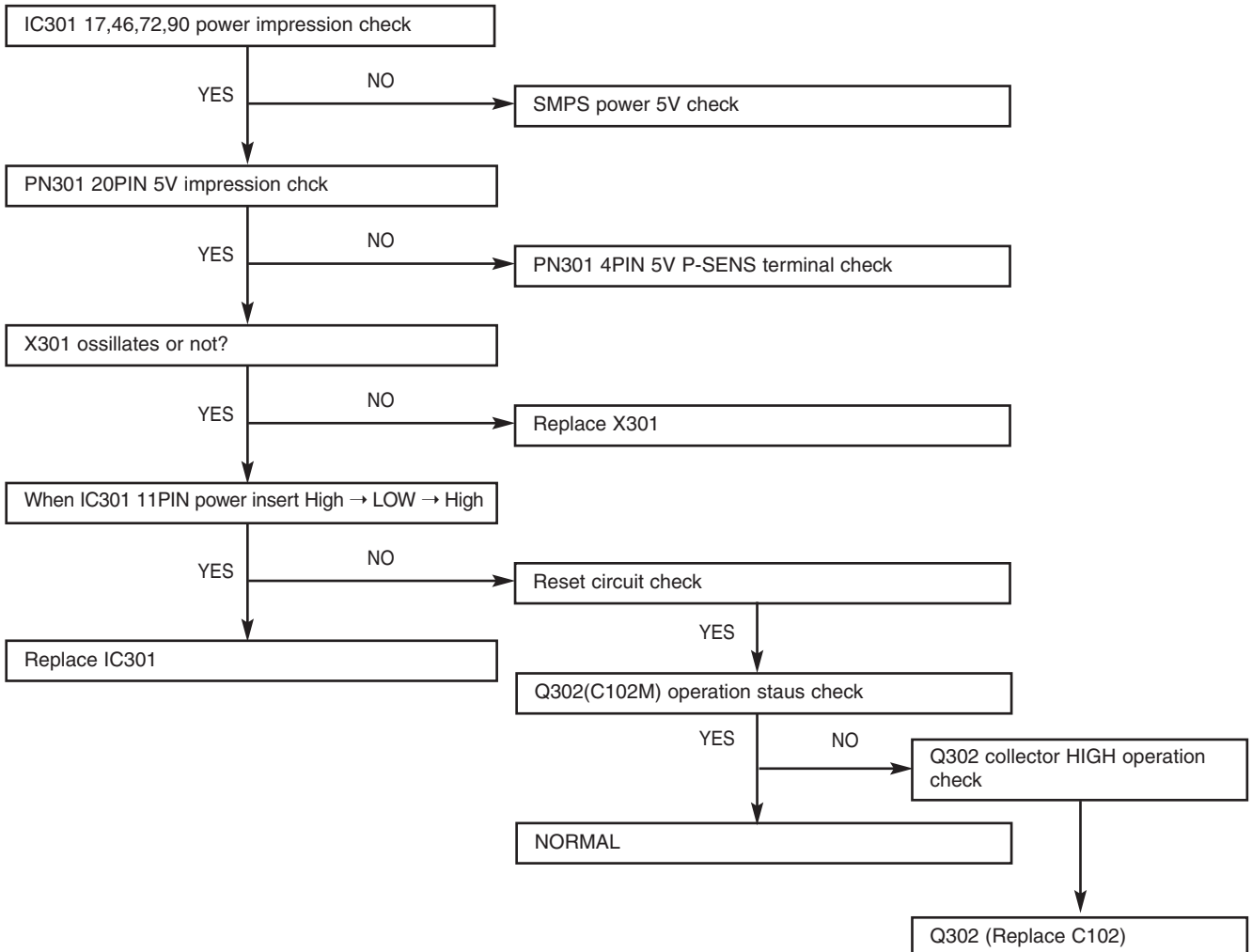

IC302, 202 (BU2090) Troubleshooting

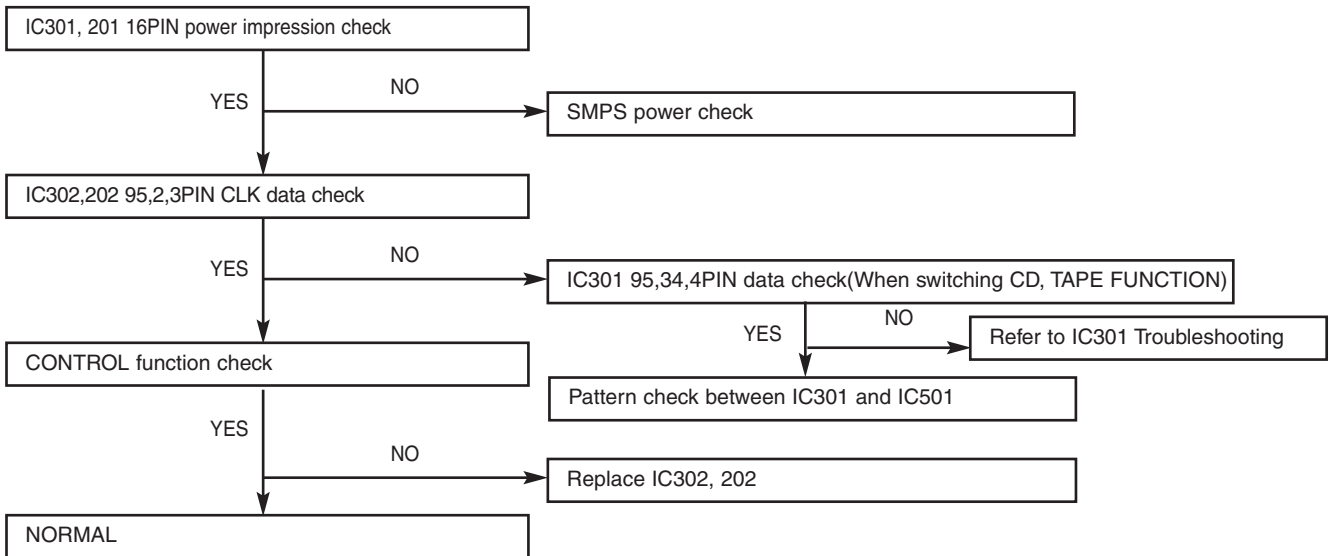

IC401 (NJW1190) Troubleshooting

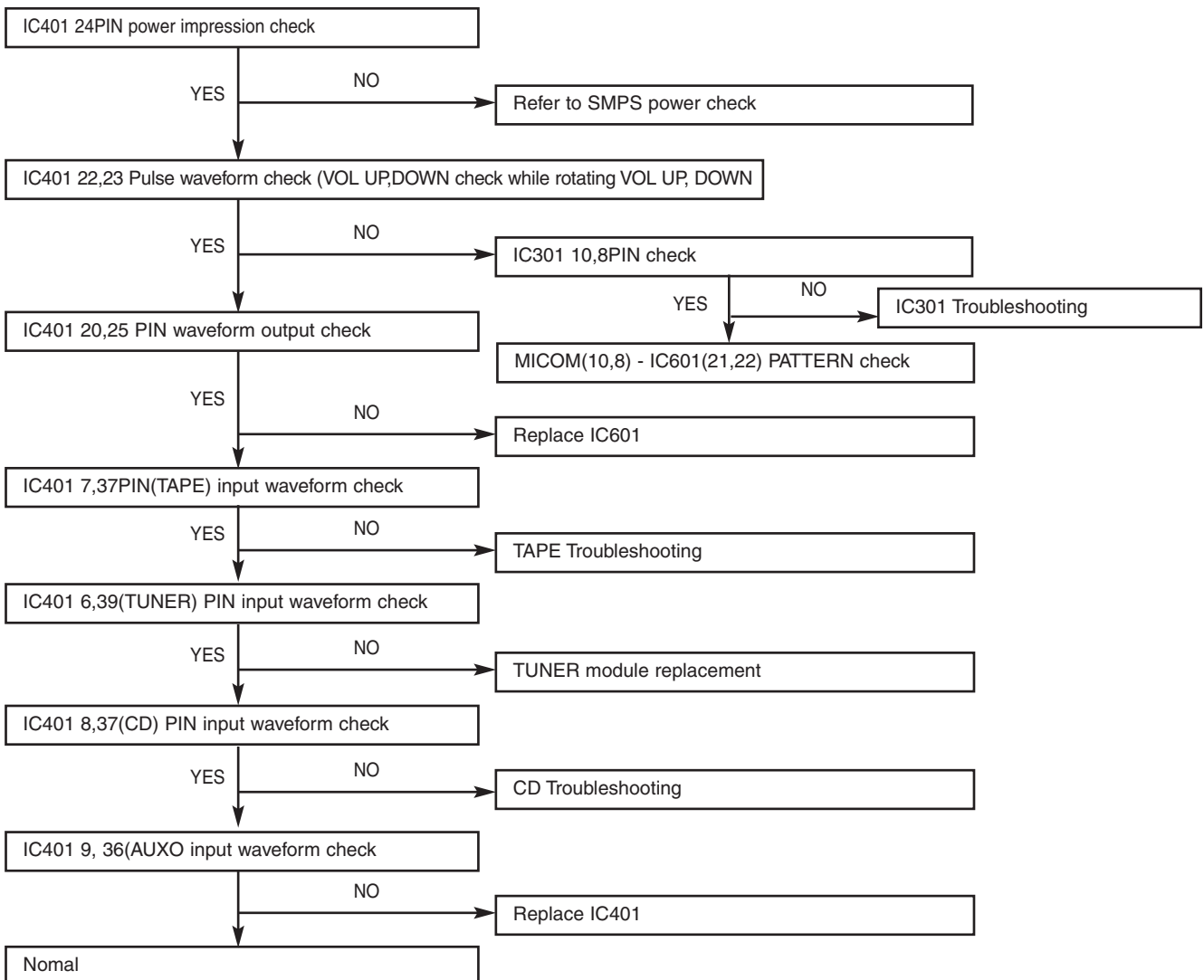

AMP MODULE Troubleshooting

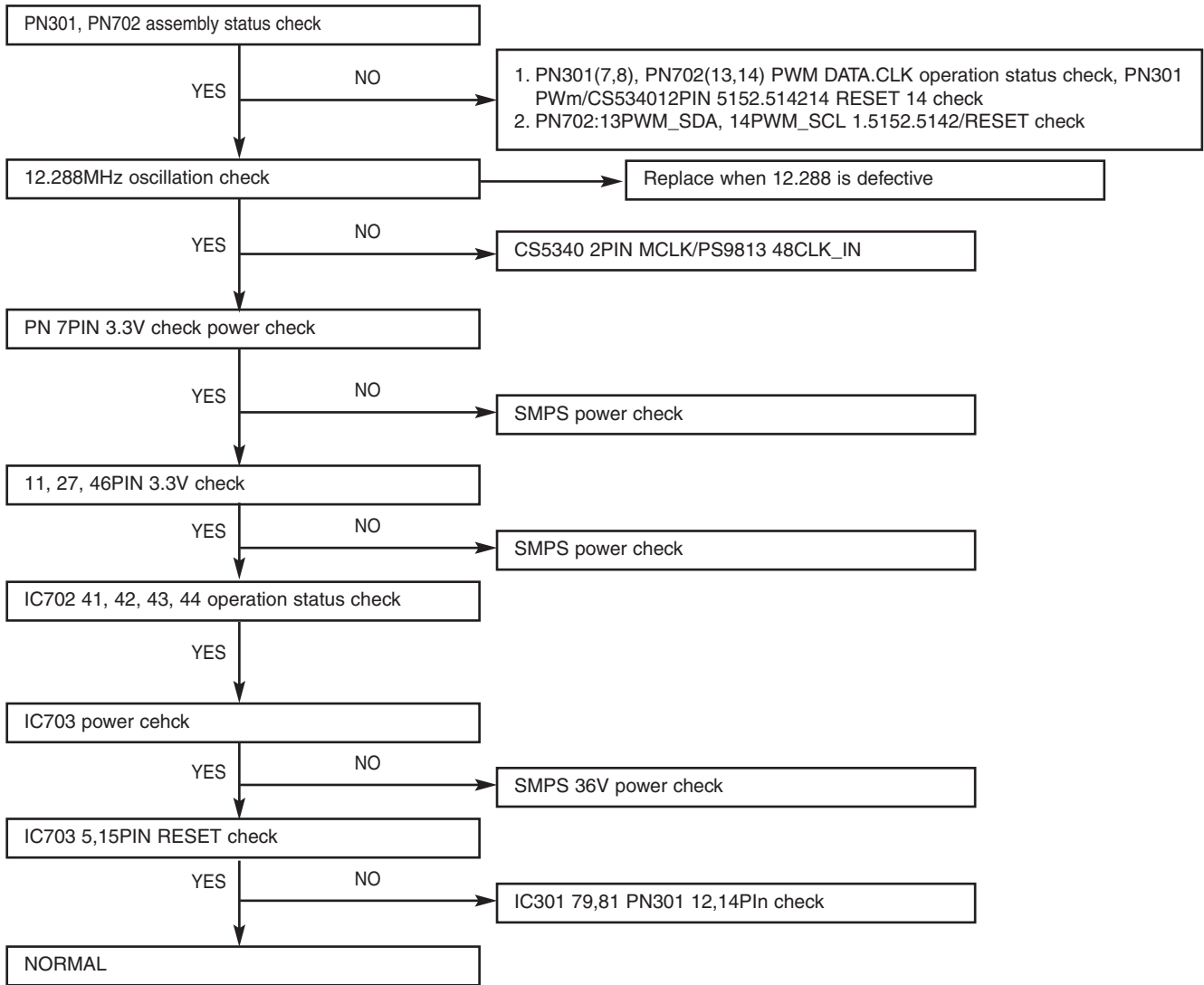

Play check

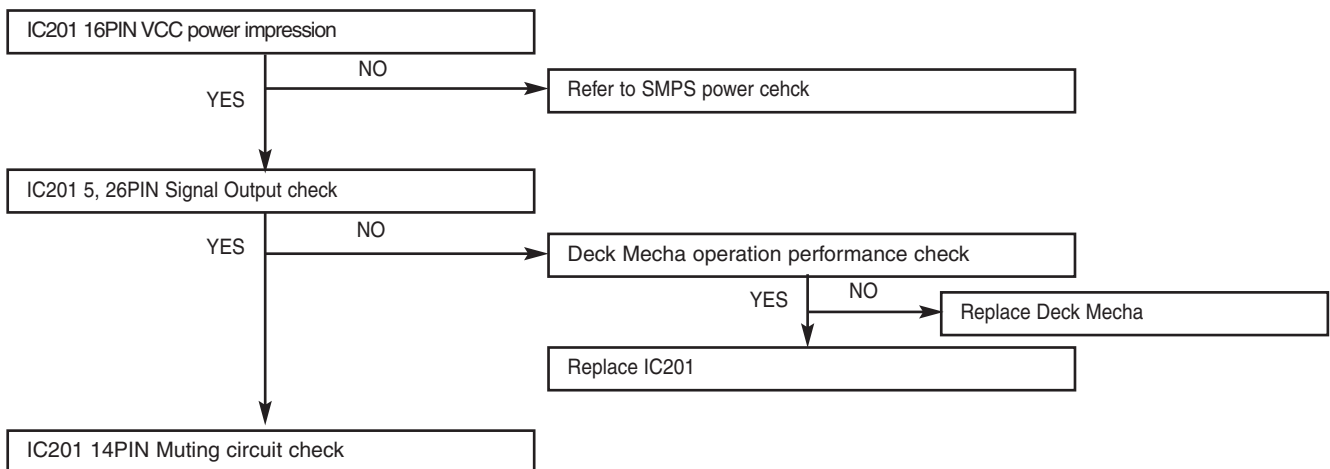

Rec check (Q252, Q202 ON :R273, R223 High)

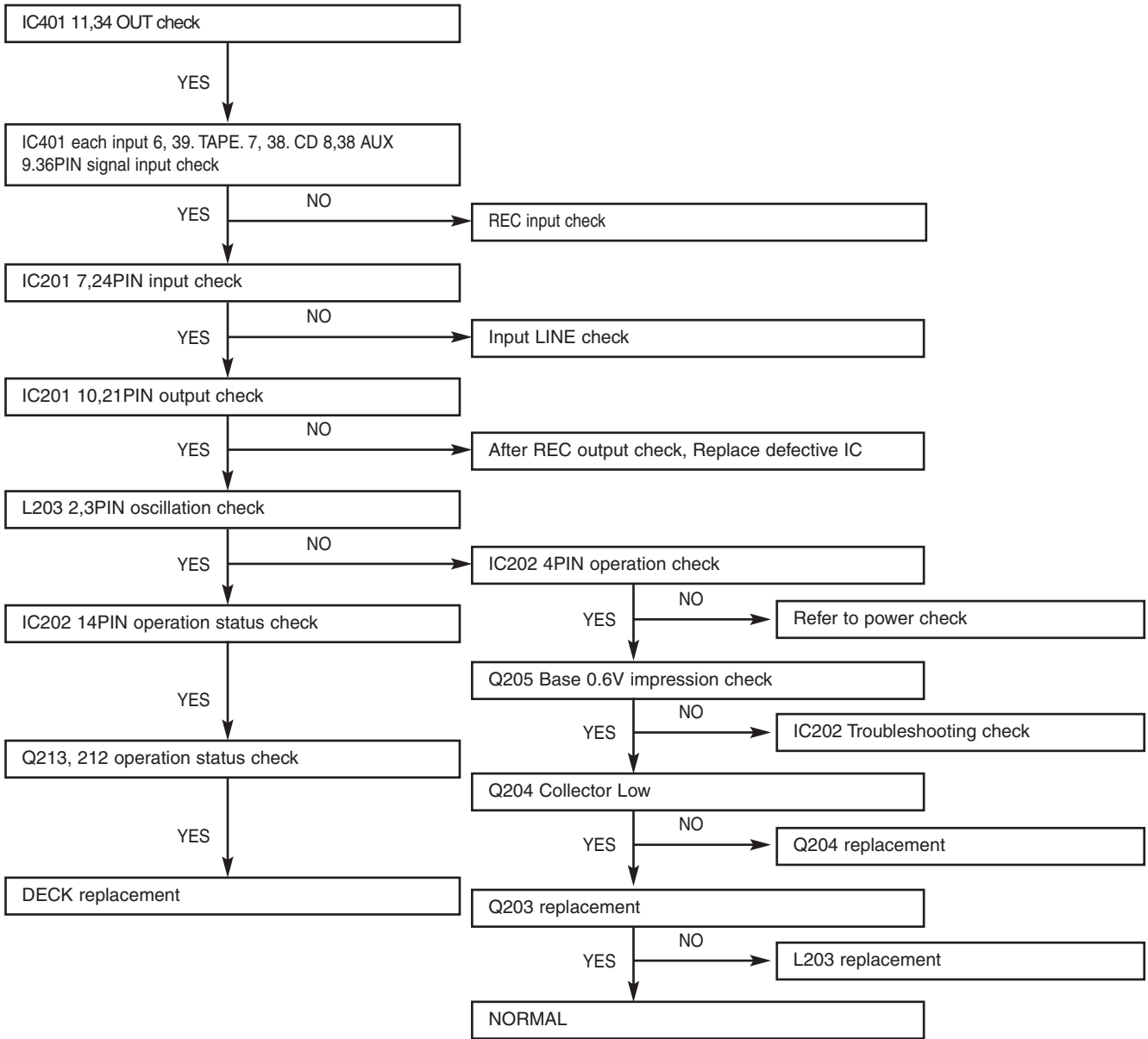

Dubbing check (“NORMAL or REC”//“HIGH”)

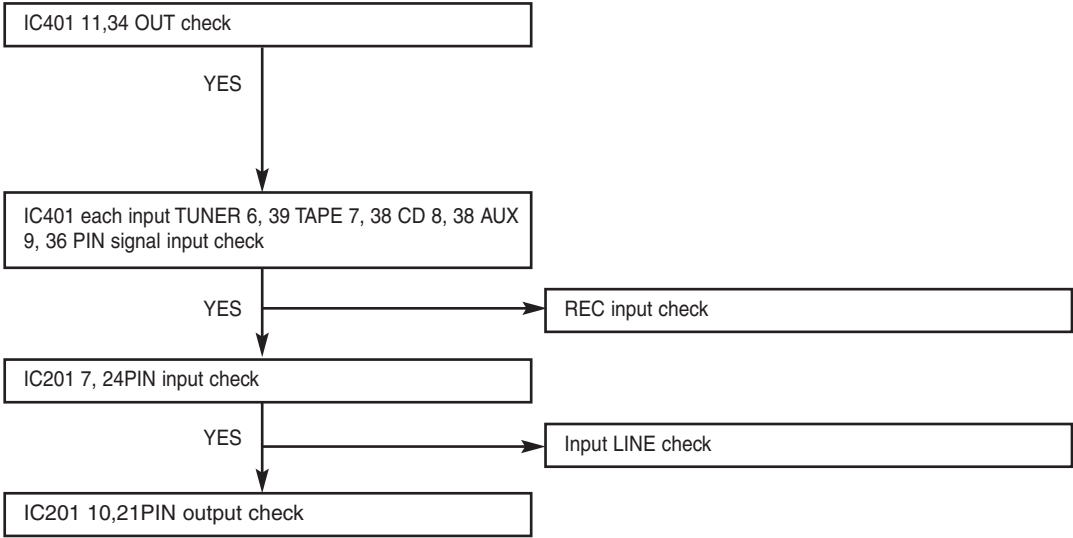

INTERNAL BLOCK DIAGRAM of ICs

• TAS5142 BLOCK DIAGRAM

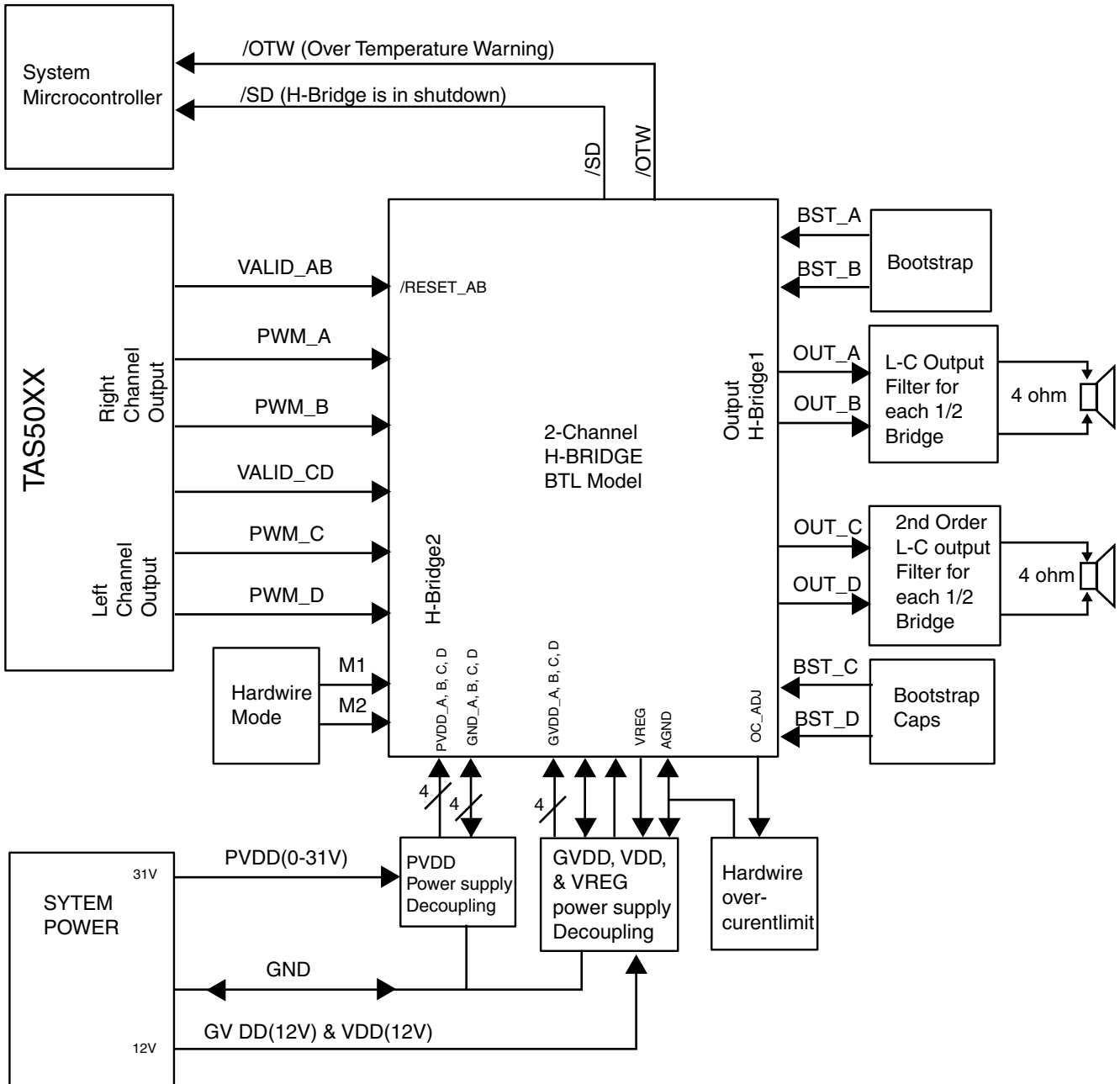

• HA12237F
BLOCK DIAGRAM

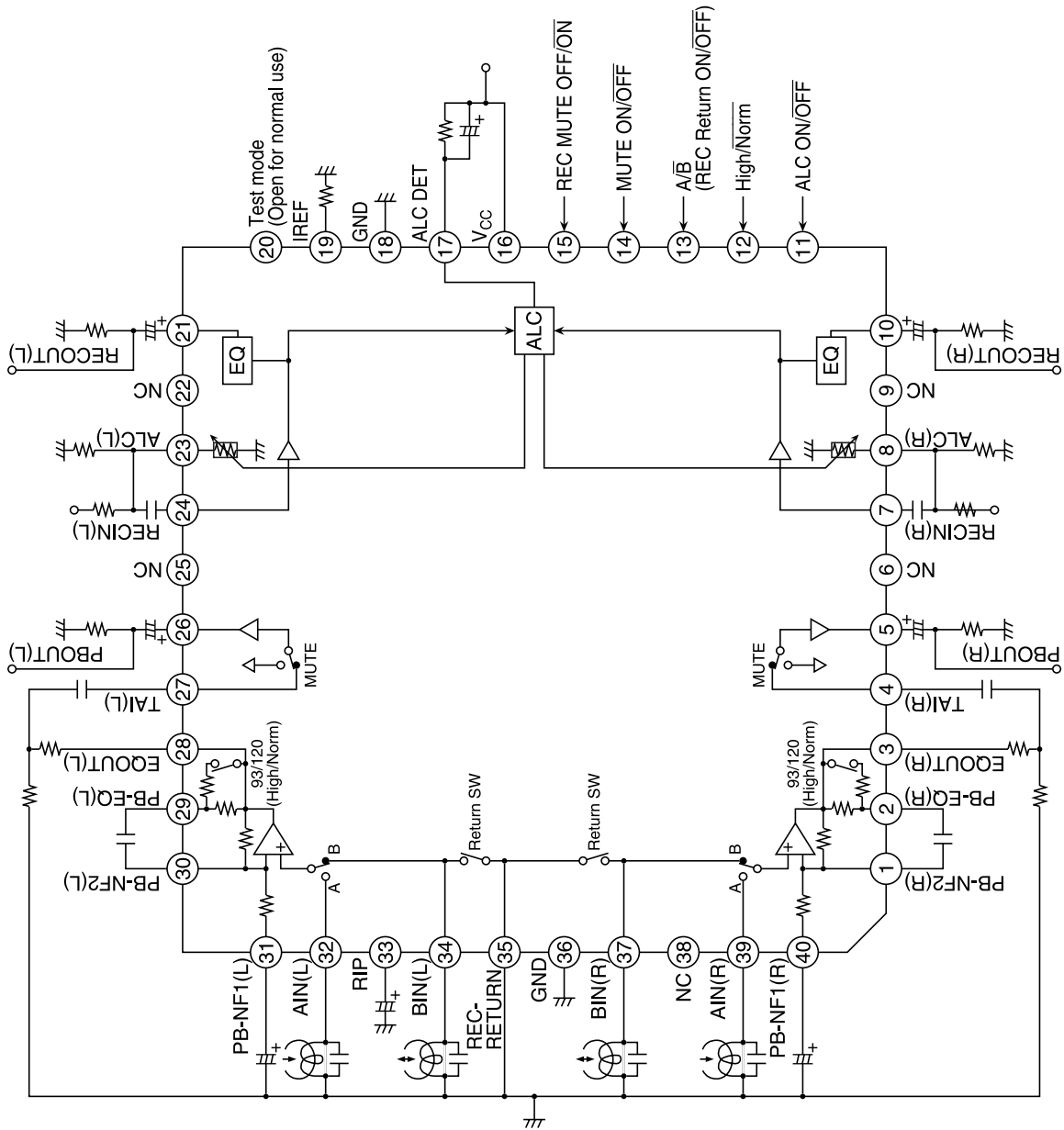

• **CS5340**
BLOCK DIAGRAM

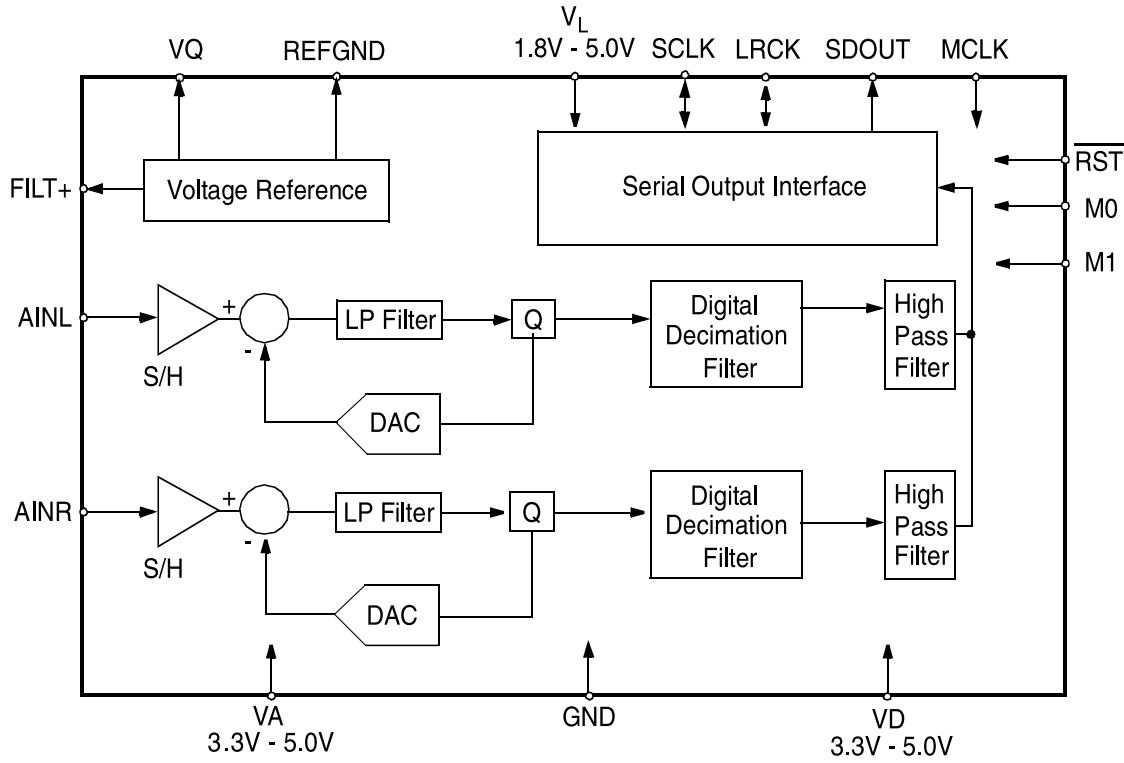

• **NJW1190**
BLOCK DIAGRAM

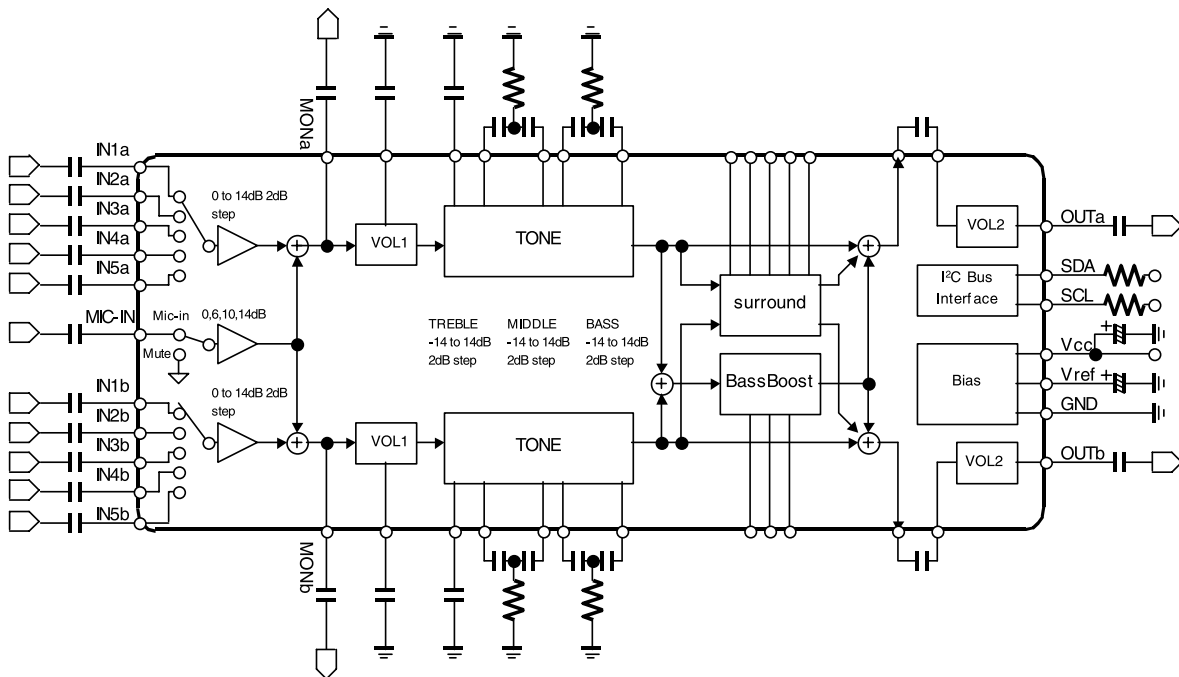

PIN FUNCTION (QFP48-P1)

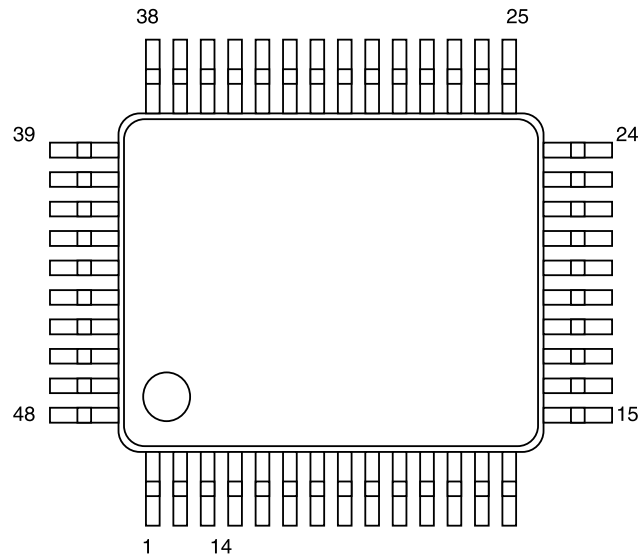

No.	SYMBOL	FUNCTION	No.	SYMBOL	FUNCT ION
1	N.C.	No Connection	25	N.C.	No Connection
2	IN 1a	Ach Input1	26	TONE-L2b	Bch Bass Filter2
3	IN 2a	Ach Input2	27	TONE-L1b	Bch Bass Filter1
4	IN 3a	Ach Input3	28	TONE-M2b	Bch Middle Filter2
5	IN 4a	Ach Input4	29	TONE-M1b	Bch Middle Filter1
6	IN 5a	Ach Input5	30	TONE-Hb	Bch Treble Filter
7	MONOUTa	Ach Monitor Output	31	VOL1-DCb	Bch Volume1 Switching Noise Rejection Capacitor
8	VOL1-DCa	Ach Volume1 Switching Noise Rejection Capacitor	32	MONOUTb	Bch Monitor Output
9	TONE-Ha	Ach Treble Filter	33	IN5b	Bch Input5
10	TONE-M1a	Ach Middle Filter1	34	IN 4b	Bch Input4
11	TONE-M2a	Ach Middle Filter2	35	IN 3b	Bch Input3
12	TONE-L1a	Ach Bass Filter1	36	IN 2b	Bch Input2
13	TONE-L2a	Ach Bass Filter2	37	IN 1b	Bch Input1
14	N.C.	No Connection	38	N.C.	No Connection
15	SROUTa	Ach Surround Output	39	BBFil3	Bass Boost Filter3
16	VOL2INa	Ach Volume2 Input	40	BBFil2	Bass Boost Filter2
17	O UTa	Ach Output	41	BBFil1	Bass Boost Filter1
18	G ND	GND	42	PSFil	Phase Shifter Filter
19	SC L	SCL Data Input (I ² C BUS)	43	Vref	Reference Voltage
20	SD A	SDA Data Input (I ² C BUS)	44	MIC-IN	Microphone Input
21	V +	Power Supply Pin	45	SRFil1	Surround Filter1
22	O UTb	Bch Output	46	SRFil2	Surround Filter2
23	VOL2INb	Bch Volume2 Input	47	VEFil1	Voice Enhancement Filter1
24	SROUTb	Bch Surround Output	48	VEFil2	Voice Enhancement Filter2

• **TAS5152**
SYSTEM BLOCK DIAGRAM

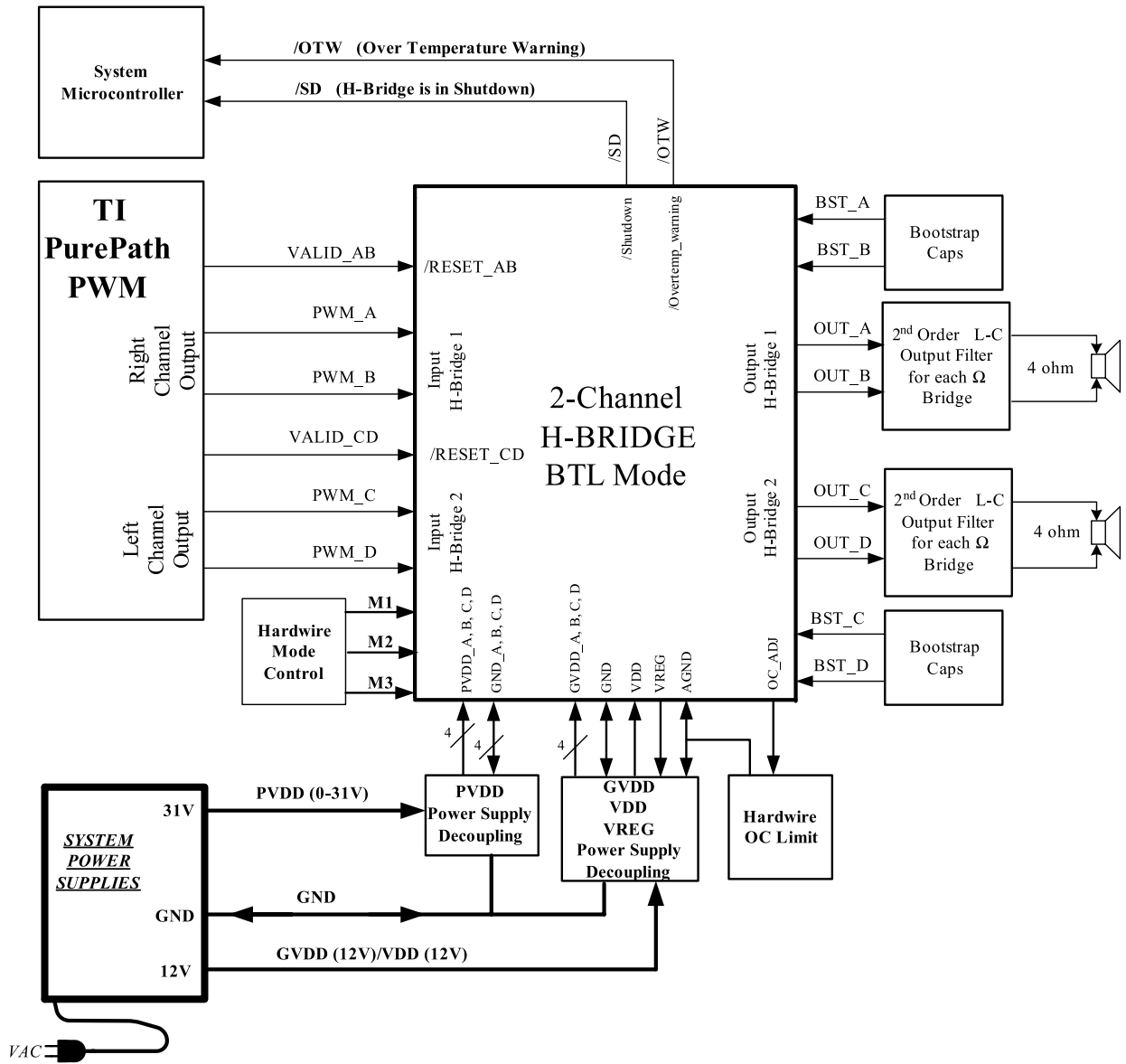

FUNCTIONAL BLOCK DIAGRAM

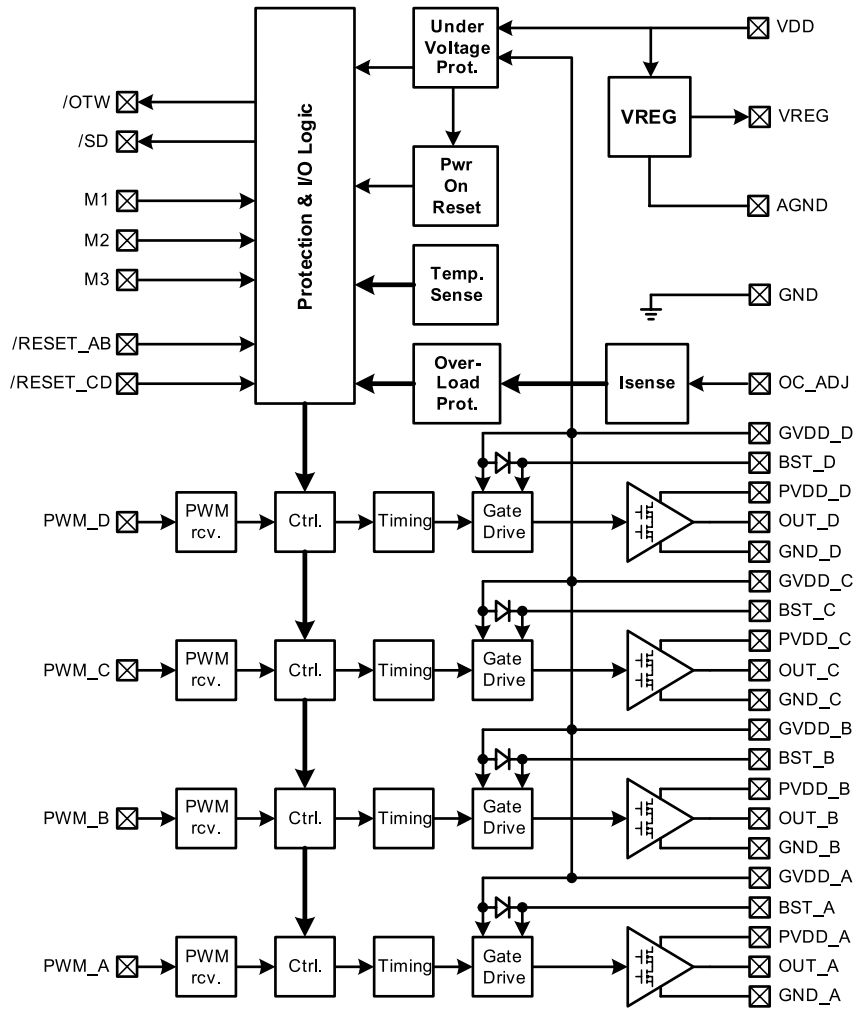

• **PS9813**
BLOCK DIAGRAM

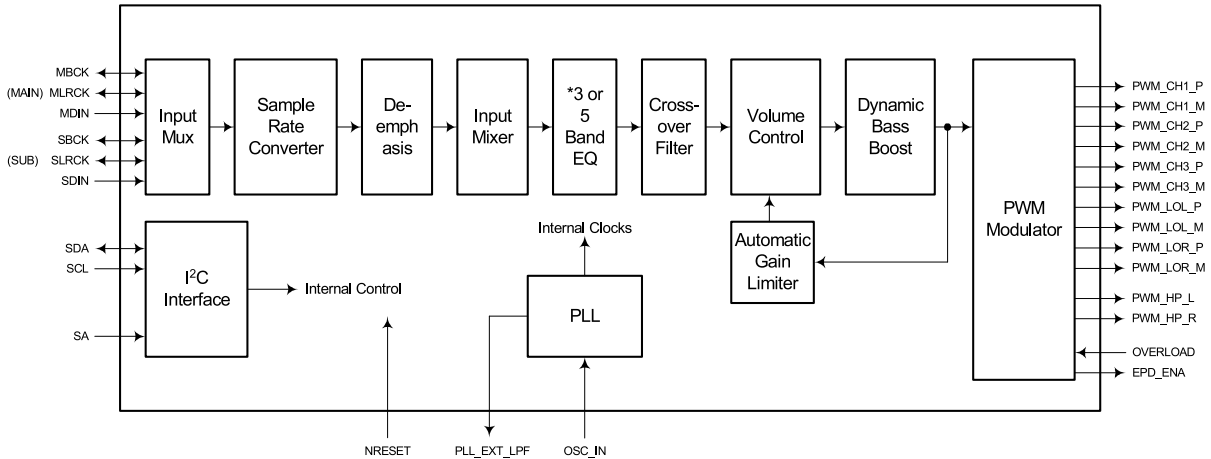

• **Pin Assignment**

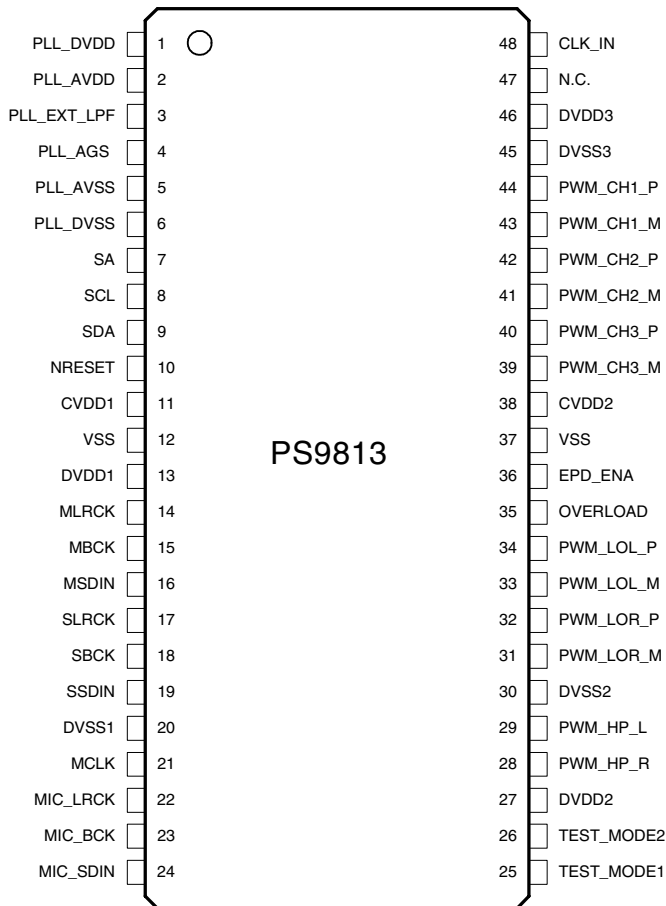

Pin Descriptions

Name	Pin NO.	Type	Description
Power and Ground			
PLL_AVDD	2	Analog Power	PLL analog power supply. 2.5V supply voltage.
PLL_AVSS	5	Analog Ground	PLL analog ground.
PLL_DVDD	1	PLL Power	PLL peripheral digital power supply. 2.5V supply voltage.
PLL_DVSS	6	PLL Ground	PLL digital ground.
PLL_AGS	4	PLL Ground	PLL Analog Ground Sensing.
VDD	11,38	Power	2.5V Digital power supply. Core power supply.
VSS	12, 37	Ground	Core digital ground.
IO_VDD	13,27,46	Power	3.3V Digital power supply. I/O power supply.
IO_VSS	12,20,30,45	Ground	I/O digital ground.
System Services			
/RESET	10 I		H/W reset signal. Active Low Schmitt-Trigger input. The Schmitt-Trigger input allows a slowly rising input to reset the chip reliably. The RESET signal must be asserted Low $\bar{1}$ during power up. De-assert High $\bar{1}$ for normal operation.
CLK_IN	48	I	External clock input. 12.288MHz is recommended. When the PLL_BYPASS is $\bar{1}$ LOW $\bar{1}$, the external clock input from CLK_IN is used as PLL reference clock source. The external oscillator generates 12.288MHz clock and the internal PLL generates 98.304MHz (12.288MHz x 8) system clock.
SA	7	I	Slave Address Set for Host Interface
PLL_EXT_LPF	3	Analog	External PLL low pass filter pin.
PCM Audio Input/Output Interface			
MLRCK	14	I/O	PCM Word clock (left-right clock) input/output of main 2-channel audio. User can select the master/slave mode of this signal. Schmitt-Trigger input.
MBCK	15	I/O	PCM bit clock input/output of main 2-channel audio. User can select the master/slave mode of this signal. Schmitt-Trigger input.
MSDIN	16	I	PCM serial data input of main 2-channel audio. Schmitt-Trigger input.
SLRCK	17	I/O	PCM Word clock (left-right clock) input/output of sub 2-channel audio. User can select the master/slave mode of this signal. Schmitt-Trigger input.
SBCK	18	I/O	PCM bit clock input/output of 2-channel audio. User can select the master/slave mode of this signal. Schmitt-Trigger input.
SBCK	18	I/O	PCM bit clock input/output of 2-channel audio. User can select the master/slave mode of this signal. Schmitt-Trigger input.
SSDIN	19	I/O	PCM serial data input of sub-channel audio. User can set this sub-channel data input pins to PCM serial data output pins. See the <i>Control Register Description</i> part.

Name	Pin NO.	Type	Description
PCM Audio Input/Output Interface			
MCLK	21	O	Main clock for external ADC. Clock frequency is 256fs.
MIC_LRCK	22	O	PCM Word clock (left-right clock) output of external microphone. Word clock rate is Fs(variable)
MIC_BCK	23	O	PCM bit clock output of external microphone. Bit clock frequency is 64 Fs (variable)
MIC_SDIN	24	I	PCM serial data input of external microphone. Schmitt-Trigger input.
PWM Audio Output			
PWM_CH1_P	44	O	Positive PWM output of channel 1.
PWM_CH1_M	43	O	Negative PWM output of channel 1.
PWM_CH2_P	42	O	Positive PWM output of channel 2.
PWM_CH2_M	41	O	Negative PWM output of channel 2.
PWM_CH3_P	40	O	Positive PWM output of channel 3.
PWM_CH3_M	39	O	Negative PWM output of channel 3.
PWM_LOL_P	34	O	Positive PWM output of Line out left
PWM_LOL_M	33	O	Negative PWM output of Line out left
PWM_LOR_P	32	O	Positive PWM output of Line out right
PWM_LOR_M	31	O	Negative PWM output of Line out right
PWM_HP_L	29	O	Positive PWM output of headphone left channel.
PWM_HP_R	28	O	Positive PWM output of headphone right channel.
System Control Interface			
SDA	9	I/O	SDA for I2C mode.
SCL	8	I	SCL for I2C mode. Schmitt-Trigger input.
Special Control Interface			
OVERLOAD	35	I	Power stage overload indication input. Polarity is programmable. Schmitt-Trigger input. When OVERLOAD is asserted, all PWM audio outputs go to $\bar{\text{LOW}}$ (if PWM_INVERT pin is $\bar{\text{LOW}}$). <i>Internal pull-down resistor.</i>
EPD_ENA	36	O	External amplifier power device enable output.
Test Mode			
TEST_MODE1	25	I	Test mode selection pin 1. In normal operation, it should be $\bar{\text{LOW}}$ or not connected. <i>Internal pull-down resistor.</i>
TEST_MODE2	26	I	Test mode selection pin 2. In normal operation, it should be $\bar{\text{LOW}}$ or not connected. <i>Internal pull-down resistor.</i>

• OTi-6888 (IC805)
BLOCK DIAGRAM

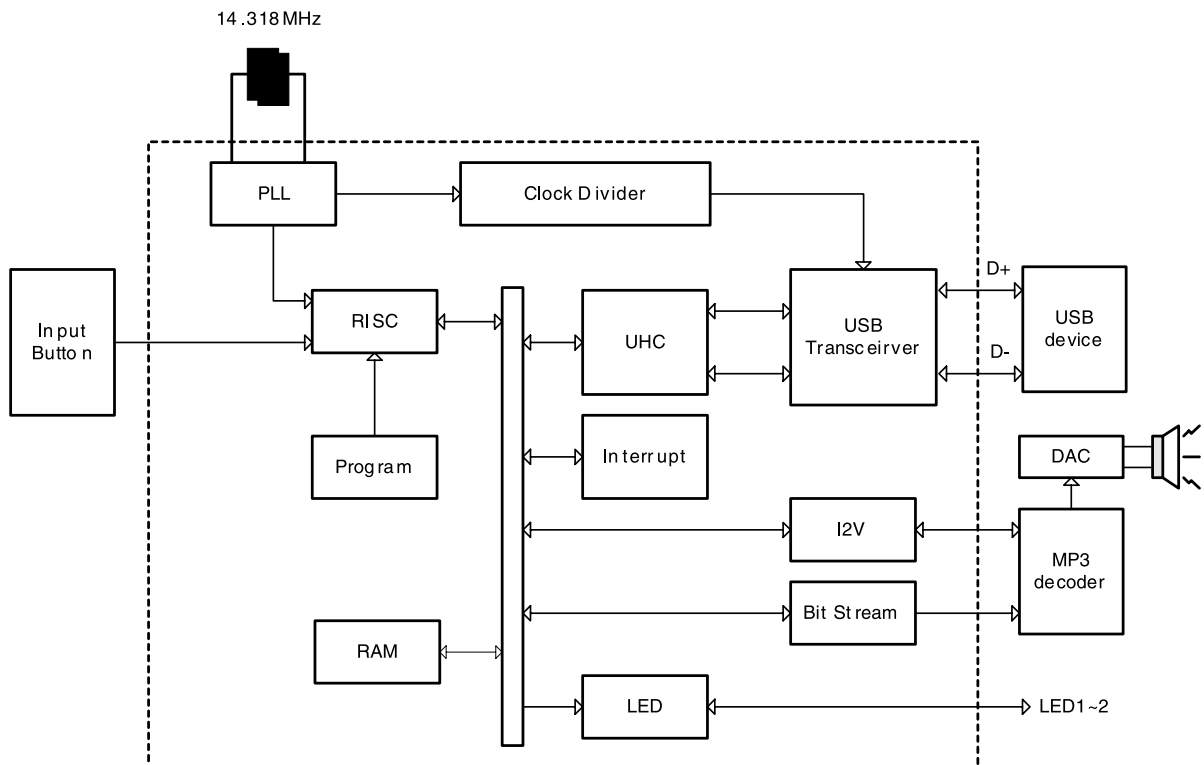

• **AM5810 (IC802)**
BLOCK DIAGRAM

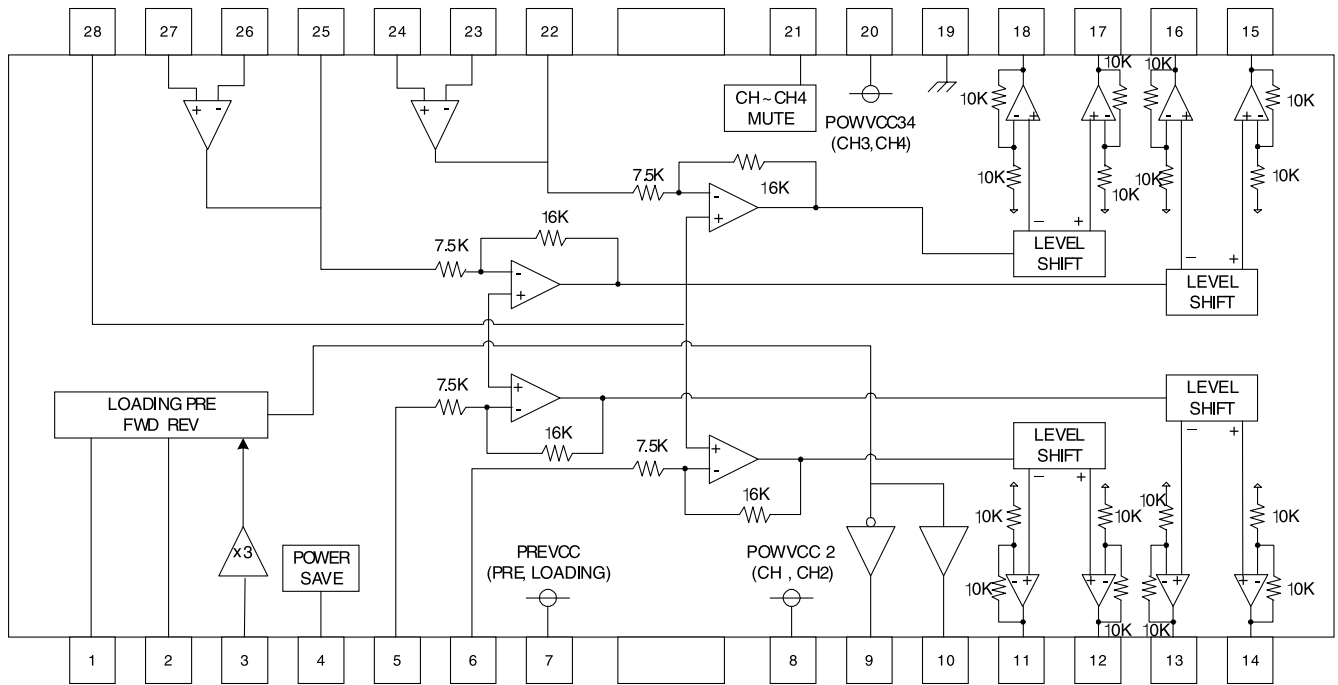

Pin configuration

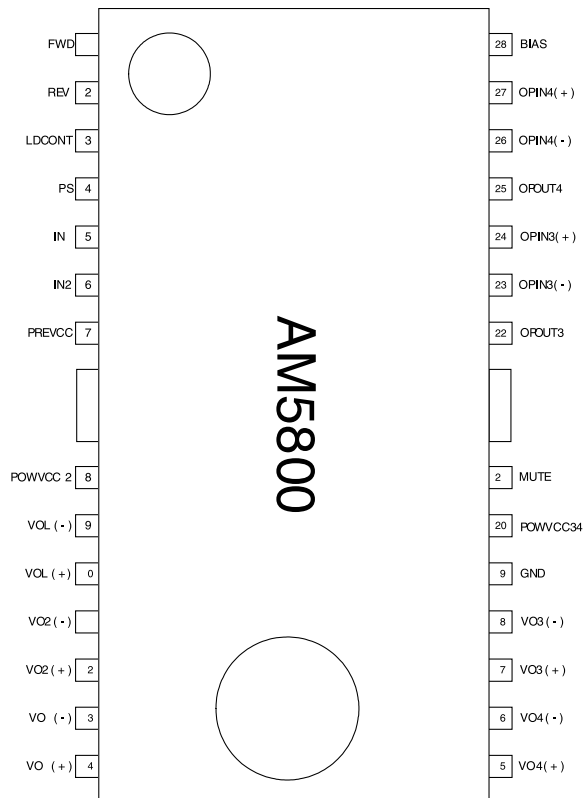

Pin Description

PIN No	Pin Name	Description
1	FWD	Input for loading forward
2	REV	Input for loading reverse
3	LDCONT	Output control terminal for loading
4	PS	Control terminal for power saving mode
5	IN1	Input 1 of CH1
6	IN2	Input 2 of CH2
7	PREVCC	Pre and loading unit power supply input terminal
8	POWVCC12	Power unit power supply input terminal (CH1, CH2)
9	VOL (-)	Inverted output of loading
10	VOL (+)	Not inverted output of loading
11	VO2 (-)	Inverted output of CH2
12	VO2 (+)	Not inverted output of CH2
13	VO1 (-)	Inverted output of CH1
14	VO1 (+)	Not inverted output of CH1
15	VO4 (+)	Not inverted output of CH4
16	VO4 (-)	Inverted output of CH4
17	VO3 (+)	Not inverted output of CH3
18	VO3 (-)	Inverted output of CH3
19	GND	Substrate ground
20	POWVCC34	Power unit power supply input terminal (CH3, CH4)
21	MUTE	Input for mute control
22	OPOUT3	Output of CH3 OP-ANP
23	OPIN3 (-)	Inverting input of CH3 OP-ANP
24	OPIN3 (+)	Not inverting input of CH3 OP-ANP
25	OPOUT4	Output of CH4 OP-ANP
26	OPIN4 (-)	Inverting input of CH4 OP-ANP
27	OPIN4 (+)	Not inverting input of CH4 OP-ANP
28	BIAS	Input of Bias-Amplifier

Application

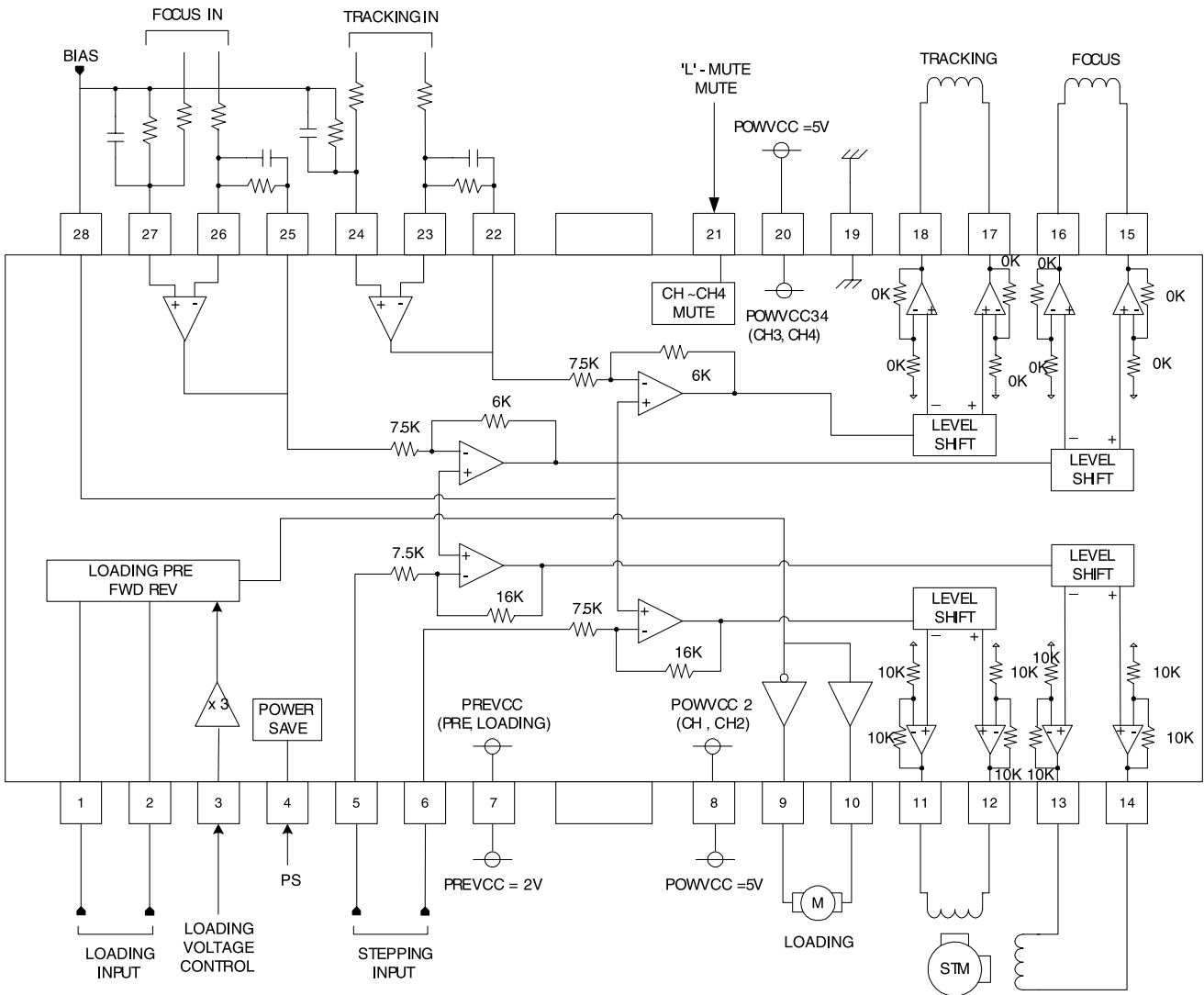

• OTi-6888
PIN CONFIGUARTION

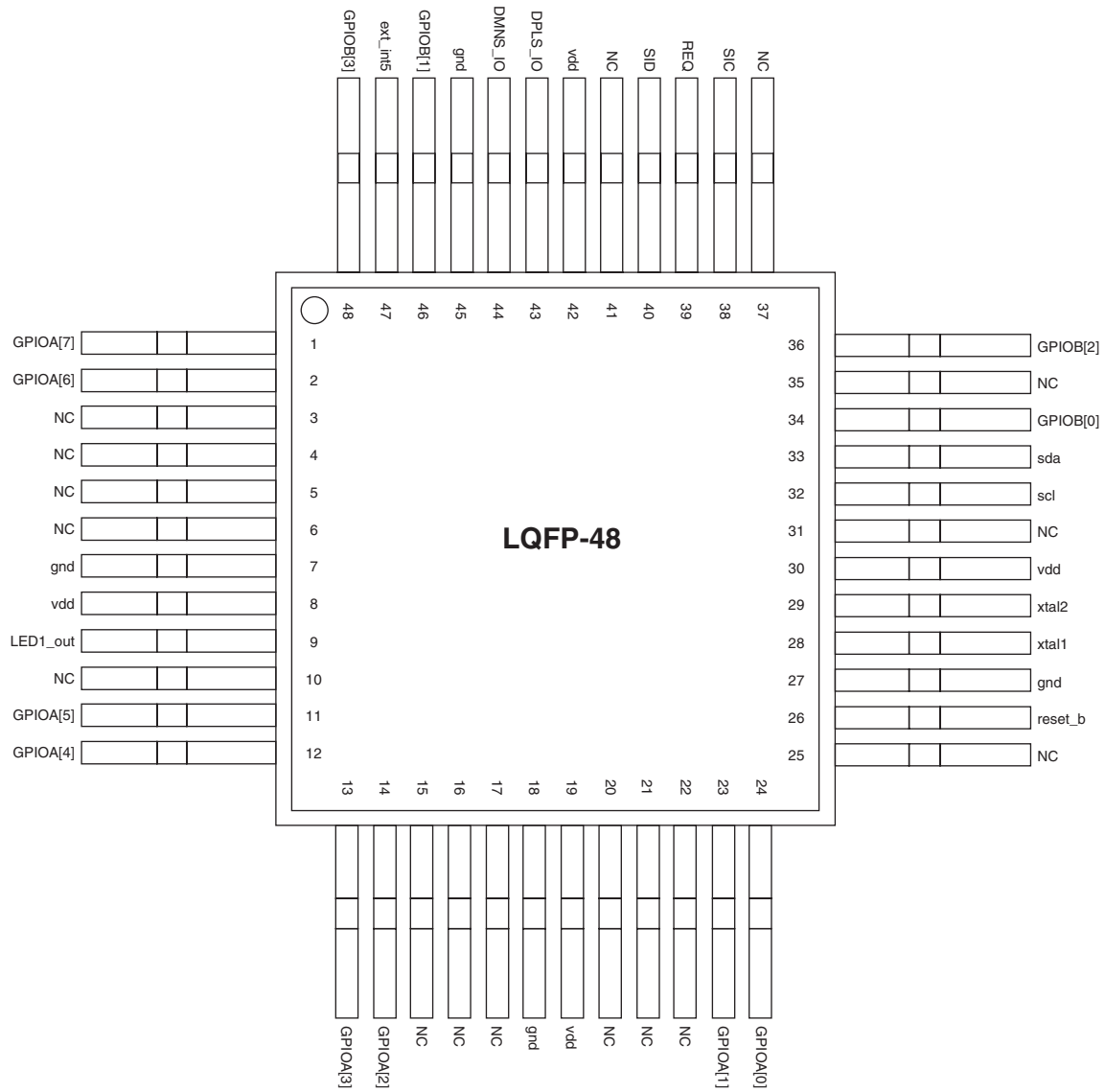

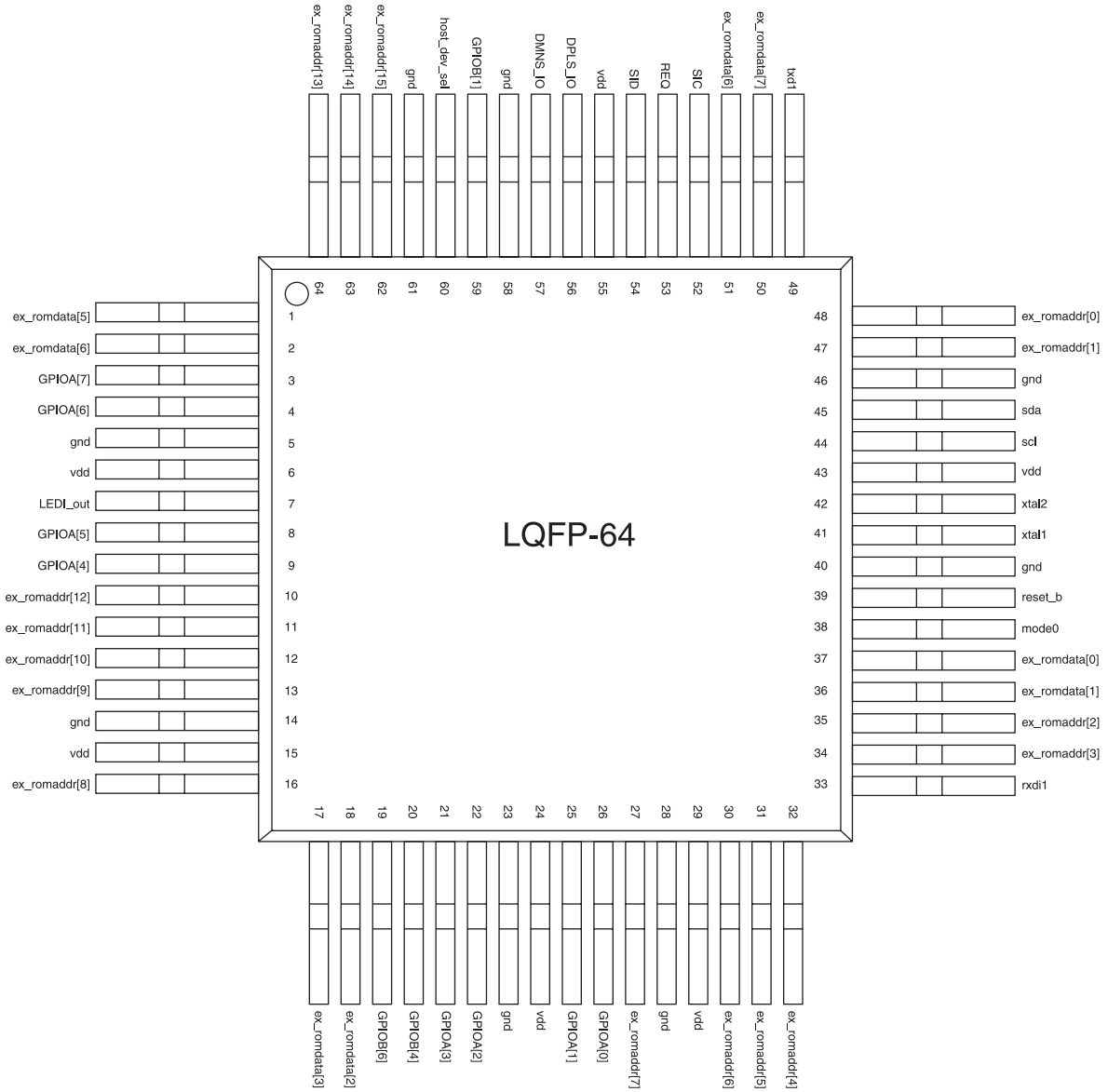

PIN DESCRIPTION

OTi-6888 has two different kinds of package, 48-pin and 64-pin. OTi-6888 with 48-pin package provides fundamental USB host function, however, it can provide external ROM functions if you choose 64-pin package.

Note: OTi-6888 with 48-pin package does not external ROM function.

Pin No.	Pin Name	Attribute	Description
1	GPIOA[7]	I/O	GPIO
2	GPIOA[6]	I/O	GPIO
3	NC		NC
4	NC		NC
5	NC		NC
6	NC		NC
7	gnd	I	gnd
8	vdd	I	vdd
9	LED1_out	O Status indication	
10	NC		NC
11	GPIOA[5]	I/O	GPIO
12	GPIOA[4]	I/O	GPIO
13	GPIOA[3]	I/O	GPIO
14	GPIOA[2]	I/O	GPIO
15	NC		NC
16	NC		NC
17	NC		NC
18	gnd	I	gnd
19	vdd	I	vdd
20	NC		NC
21	NC		NC
22	NC		NC
23	GPIOA[1]	I/O	GPIO
24	GPIOA[0]	I/O	GPIO
25	NC	O	NC
26	reset_b	I	Power on reset input , low active
27	gnd	I	gnd
28	xtal1	I	Crystal input
29	xtal2	O	Crystal output
30	vdd	I	vdd
31	NC		NC
32	scl	O	The clock pin for I2C
33	sda	I/O	The data pin for I2C
34	GPIOB[0]	I/O	GPIO
35	NC		NC
36	GPIOB[2]	I/O	GPIO
37	NC		NC
38	SIC	O	The clock pin for bit stream
39	REQ	I	The request pin for bit stream
40	SID	O	The data pin for bit stream
41	NC	O	NC
42	vdd	I	vdd
43	DPLS_IO	I/O	USB D+
44	DMNS_IO	I/O	USB D-
45	gnd	I	gnd
46	GPIOB[1]	I/O	GPIO
47	ext_int5	I	External interrupt input
48	GPIOB[3]	I/O	GPIO

Note : OTi-6888 with 64-pin package with External ROM functions.

Pin No.	Pin Name	Attribute	Description
1	ex_romdata [5]	I	ex_romdata_pad [5]
2	ex_romdata [4]	I	ex_romdata_pad [4]
3	GPIOA [7]	I/O	GPIOA_pad [7]
4	GPIOA [6]	I/O	GPIOA_pad [6]
5	gnd	I	gnd
6	vdd	I	vdd
7	LED1_out	O	LED1_out_pad
8	GPIOA [5]	I/O	GPIOA_pad [5]
9	GPIOA [4]	I/O	GPIOA_pad [4]
10	ex_romaddr [12]	O	ex_romaddr_pad [12]
11	ex_romaddr [11]	O	ex_romaddr_pad [11]
12	ex_romaddr [10]	O	ex_romaddr_pad [10]
13	ex_romaddr [9]	O	ex_romaddr_pad [9]
14	gnd	I	gnd
15	vdd	I	vdd
16	ex_romaddr [8]	I	ex_romaddr_pad [8]
17	ex_romdata [3]	I	ex_romdata_pad [3]
18	ex_romdata [2]	I	ex_romdata_pad [2]
19	GPIOB [6]	I/O	GPIOB_pad [6]
20	GPIOB [4]	I/O	GPIOB_pad [4]
21	GPIOA [3]	I/O	GPIOA_pad [3]
22	GPIOA [2]	I/O	GPIOA_pad [2]
23	gnd	I	gnd
24	vdd	I	vdd
25	GPIOA [1]	I/O	GPIOA_pad [1]
26	GPIOA [0]	I/O	GPIOA_pad [0]
27	ex_romaddr [7]	O	ex_romaddr_pad [7]
28	gnd	I	gnd
29	vdd	I	vdd
30	ex_romaddr [6]	O	ex_romaddr_pad [6]
31	ex_romaddr [5]	O	ex_romaddr_pad [5]
32	ex_romaddr [4]	O	ex_romaddr_pad [4]
33	rxdi1	I	rxdi1_pad
34	ex_romaddr [3]	O	ex_romaddr_pad [3]
35	ex_romaddr [2]	O	ex_romaddr_pad [2]
36	ex_romdata [1]	O	ex_romdata_pad [1]
37	ex_romdata [0]	O	ex_romdata_pad [0]
38	mode0	I	mode0_pad
39	reset_b	I	reset_b_pad
40	gnd	I	gnd
41	xtal1	I	xtal1_pad
42	xtal2	O	xtal2_pad
43	vdd	I	vdd
44	scl	O	scl_pad
45	sda	I/O	sda_pad
46	gnd	I	gnd
47	ex_romaddr [1]	O	ex_romaddr_pad [1]
48	ex_romaddr [0]	O	ex_romaddr_pad [0]
49	txd1	O	txd1_pad
50	ex_romdata [7]	I	ex_romdata_pad [7]
51	ex_romdata [6]	I	ex_romdata_pad [6]
52	SIC	O	SIC_pad
53	REQ	I	REQ_pad
54	SID	O	SID_pad
55	vdd	I	vdd
56	DPLS_IO	I/O	DPLS_IO_pad
57	DMNS_IO	I/O	DMNS_IO_pad
58	gnd	I	gnd
59	GPIOB [1]	I/O	GPIOB_pad [1]
60	host_dev_sel	I	host_dev_sel_pad
61	gnd	I	gnd
62	ex_romaddr [15]	O	ex_romaddr_pad [15]
63	ex_romaddr [14]	O	ex_romaddr_pad [14]
64	ex_romaddr [13]	O	ex_romaddr_pad [13]

□ BLOCK DIAGRAM

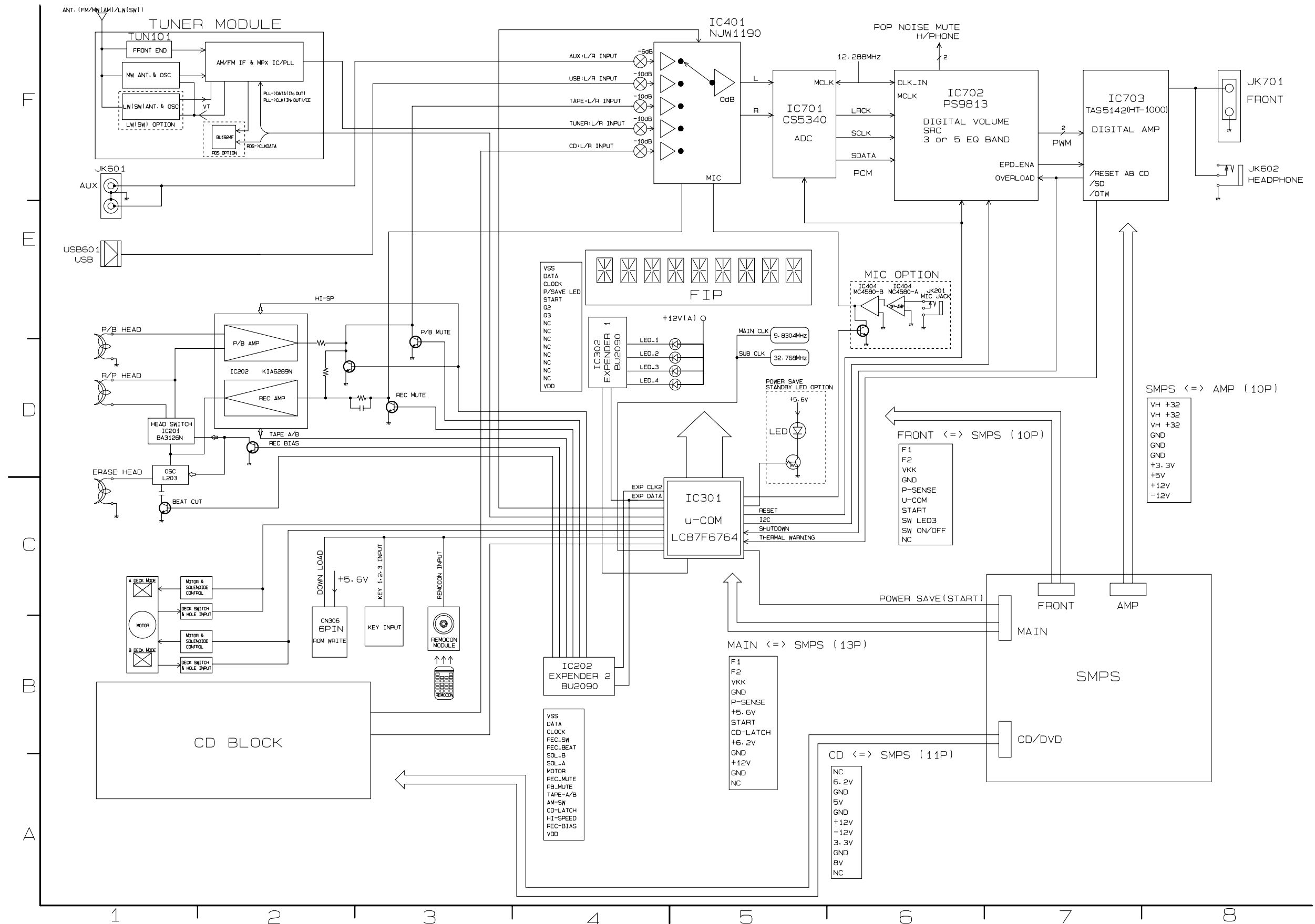

SCHEMATIC DIAGRAMS

MAIN SCHEMATIC DIAGRAM

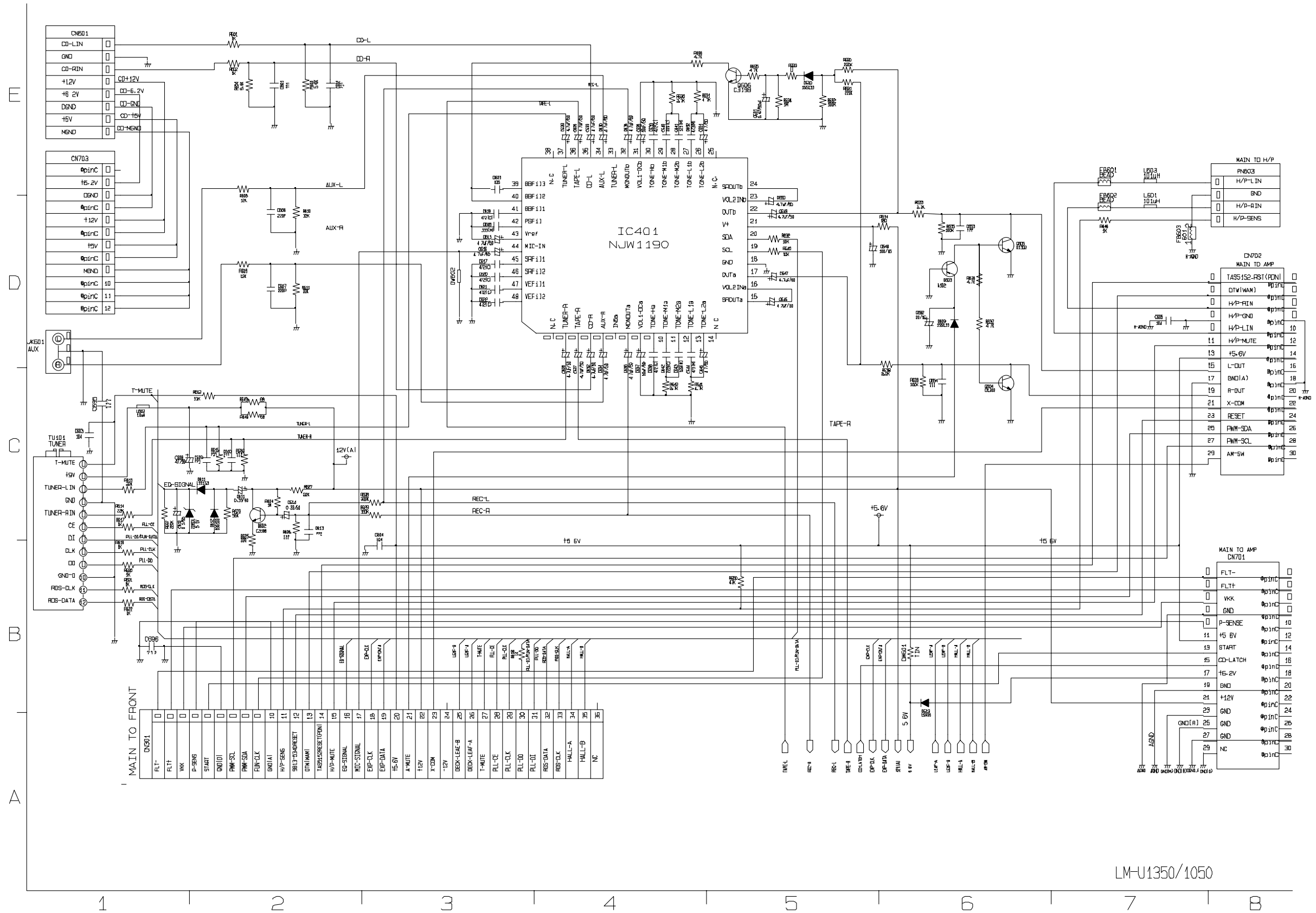

• DECK SCHEMATIC DIAGRAM

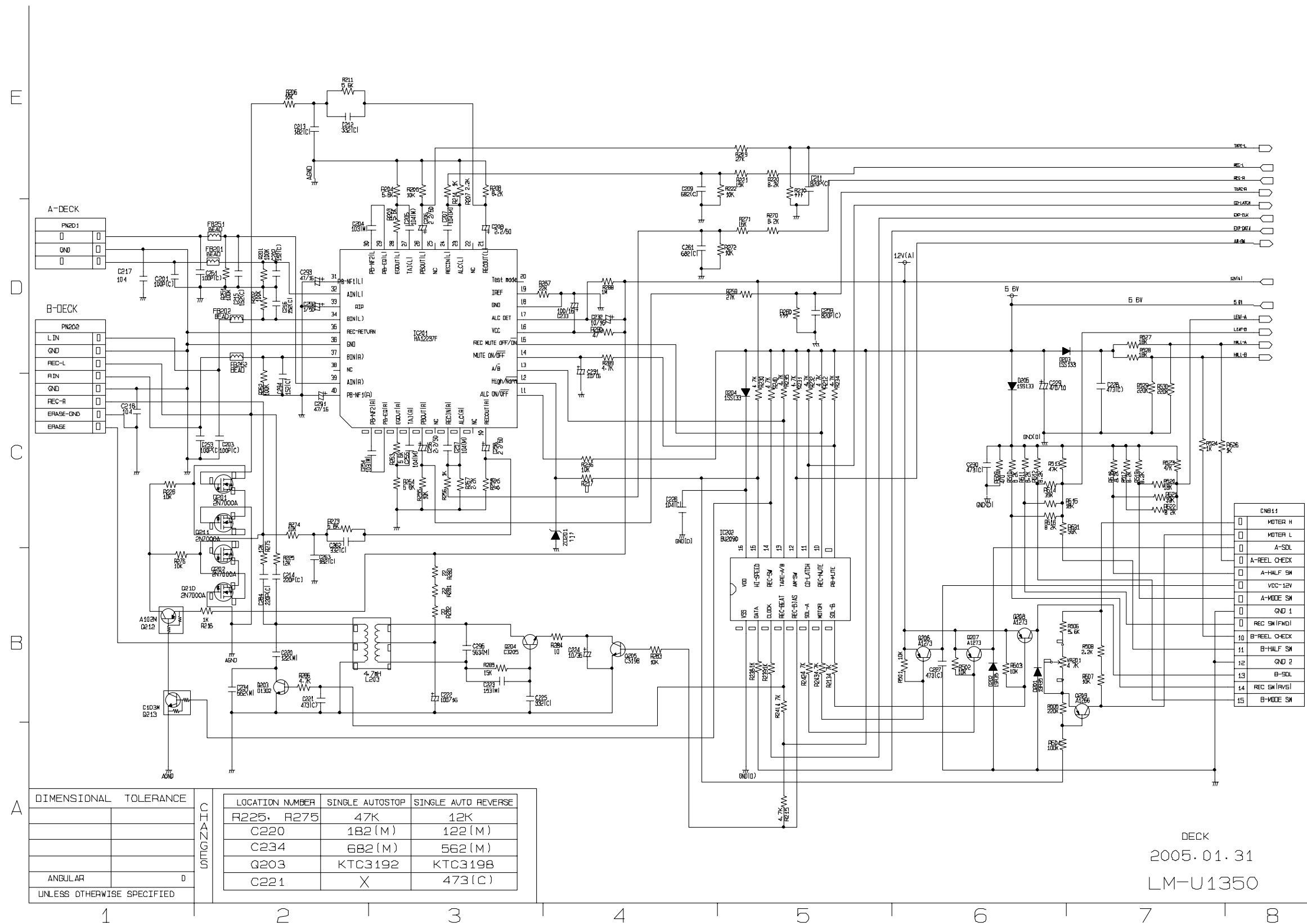

DIMENSIONAL TOLERANCE	
ANGULAR	D
UNLESS OTHERWISE SPECIFIED	

LOCATION NUMBER	SINGLE AUTOSTOP	SINGLE AUTO REVERSE
R225, R275	47K	12K
C220	182 (M)	122 (M)
C234	682 (M)	562 (M)
Q203	KTC3192	KTC3198
C221	X	473 (C)

DECK
2005.01.31
LM-U1350

• POWER SCHEMATIC DIAGRAM

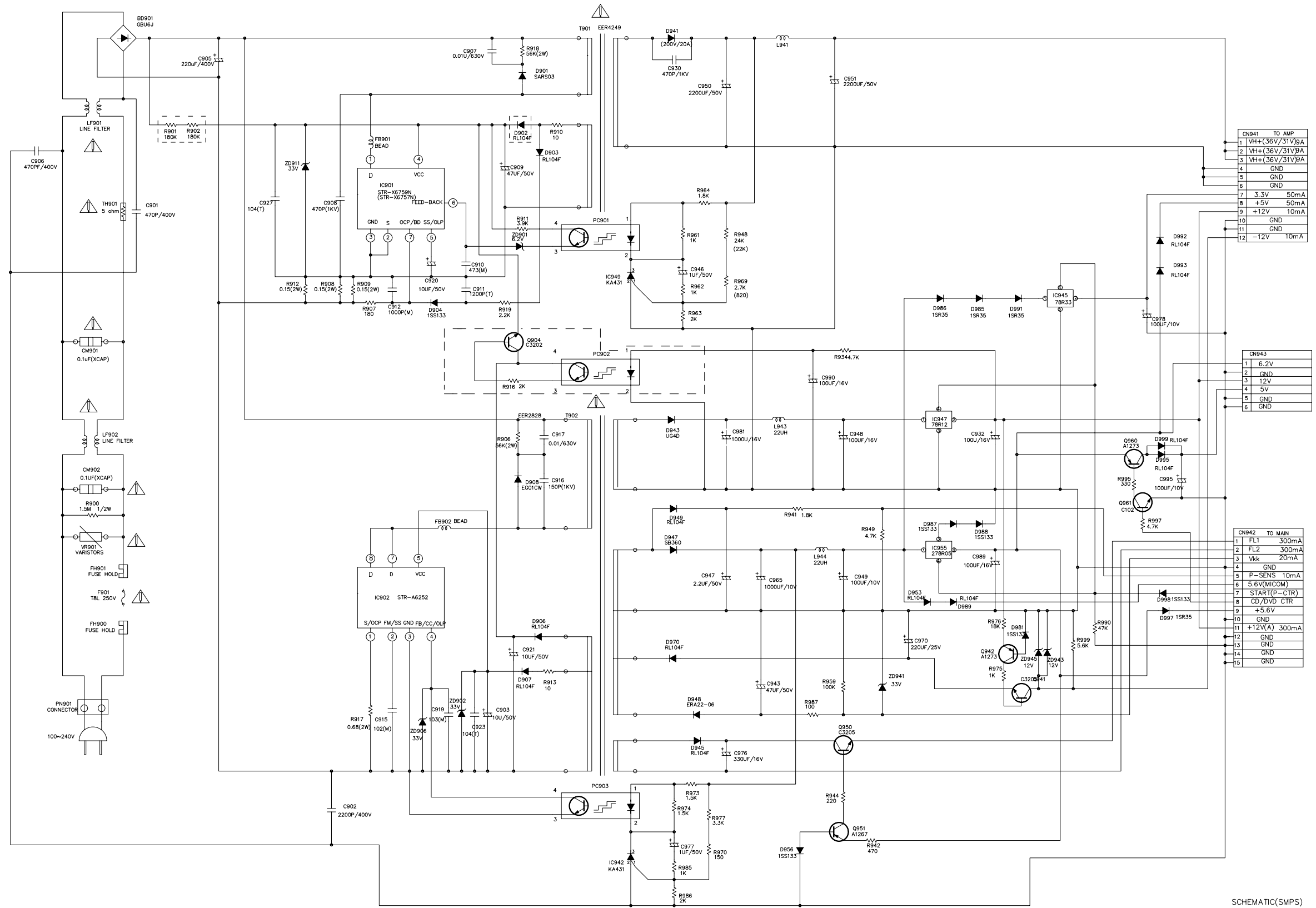

1	VH+(36V/31V)9A
2	VH+(36V/31V)9A
3	VH+(36V/31V)9A
4	GND
5	GND
6	GND
7	3.3V 50mA
8	+5V 50mA
9	+12V 10mA
10	GND
11	GND
12	-12V 10mA

1	6.2V
2	GND
3	12V
4	5V
5	GND
6	GND

1	FL1 300mA
2	FL2 300mA
3	Vkk 20mA
4	GND
5	P-SENS 10mA
6	5.6V(MICOM)
7	START(P-CTR)
8	CD/DVD CTR
9	+5.6V
10	GND
11	+12V(A) 300mA
12	GND
13	GND
14	GND
15	GND

• CDP SCHEMATIC DIAGRAM

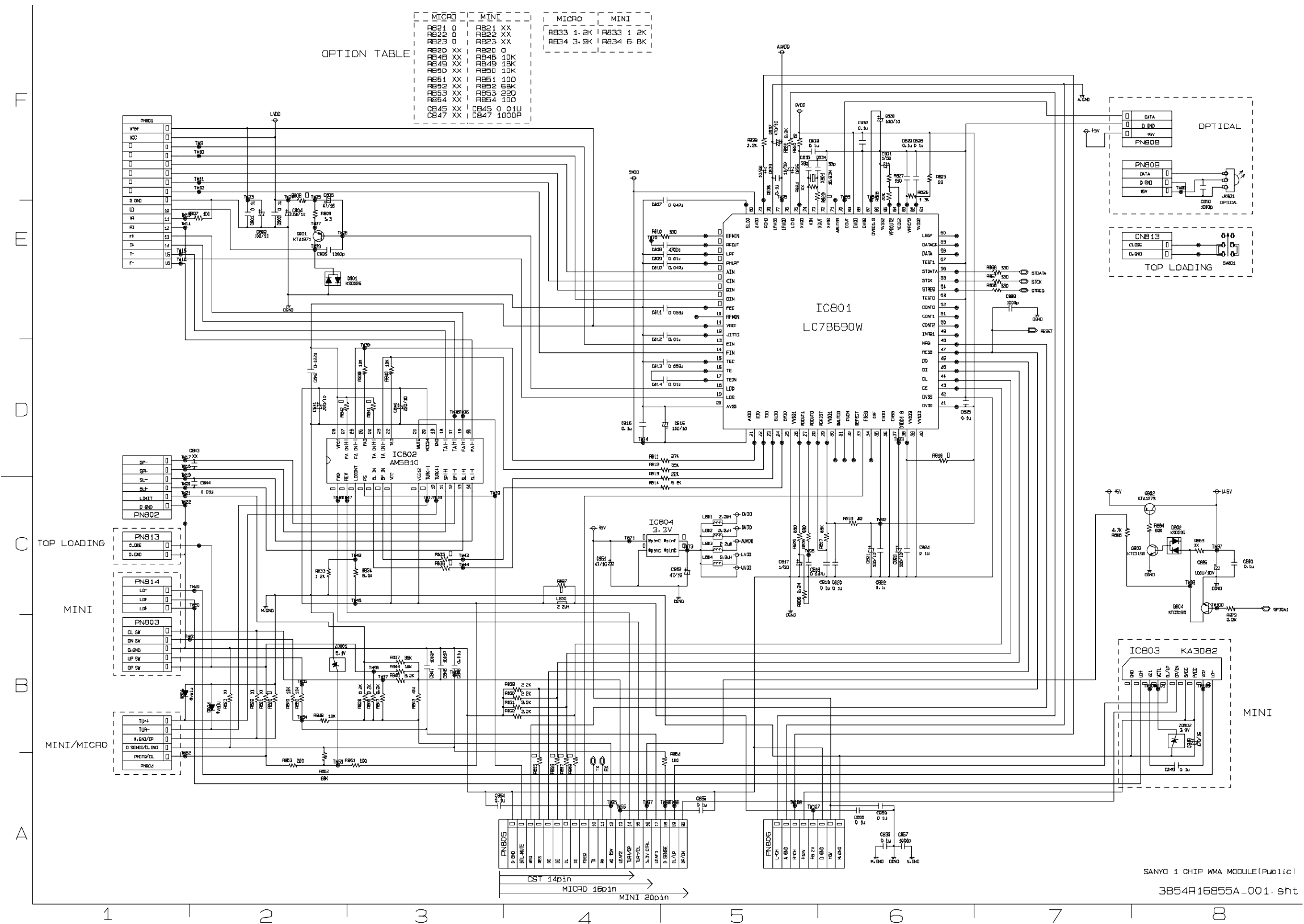

OPTION TABLE

MICRO		MINI	
RB21	00	RB21	XX
RB22	00	RB22	XX
RB23	00	RB23	XX
RB24	XX	RB24	10K
RB25	XX	RB25	10K
RB26	XX	RB26	10K
RB27	XX	RB27	10K
RB28	XX	RB28	10K
RB29	XX	RB29	10K
RB30	XX	RB30	10K
RB31	XX	RB31	100
RB32	XX	RB32	220
RB33	XX	RB33	220
RB34	XX	RB34	100
CB45	XX	CB45	0.01u
CB46	XX	CB46	100p
CB47	XX	CB47	1000p

• AMP SCHEMATIC DIAGRAM

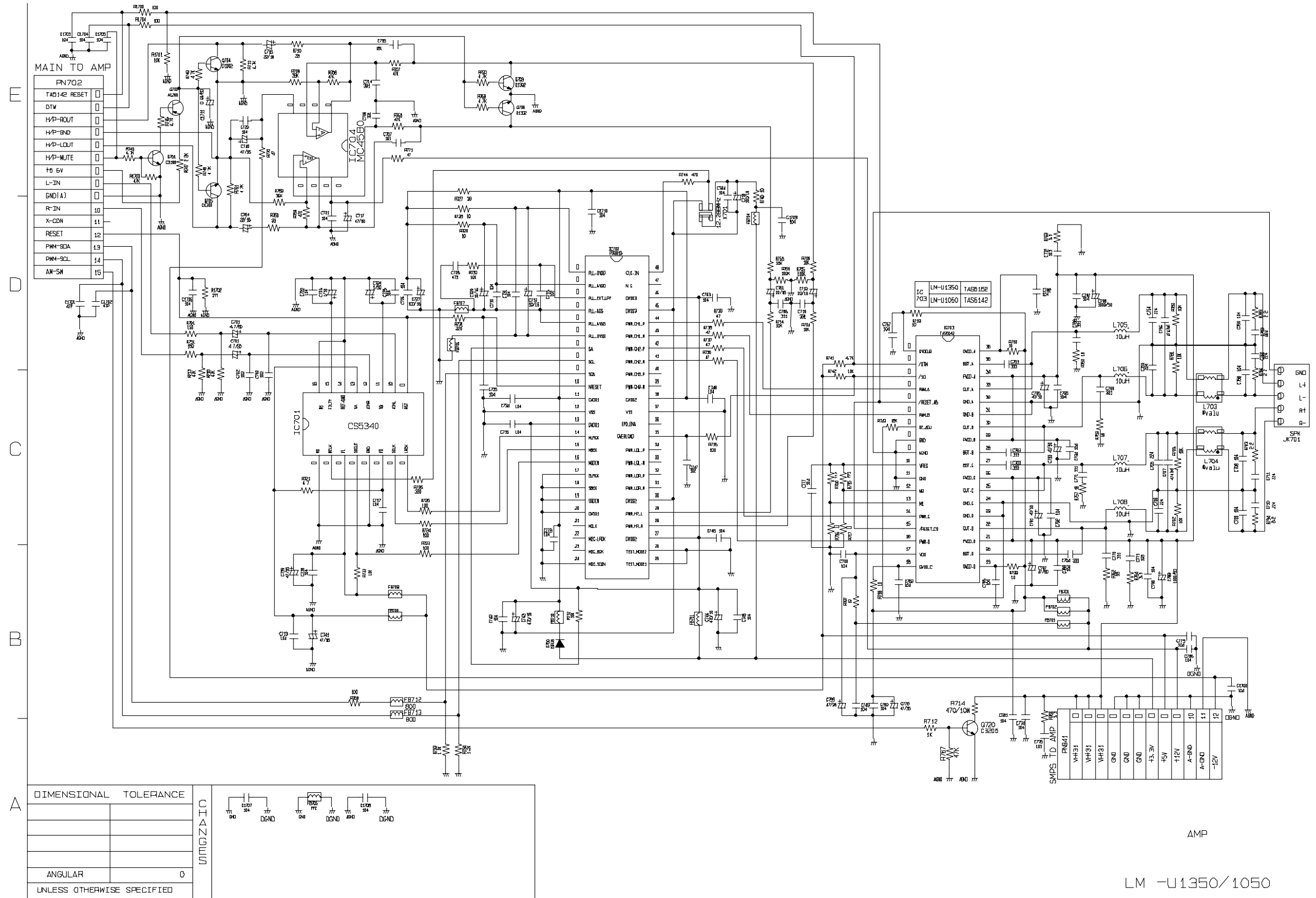

DIMENSIONAL TOLERANCE	
ANGULAR	0
UNLESS OTHERWISE SPECIFIED	

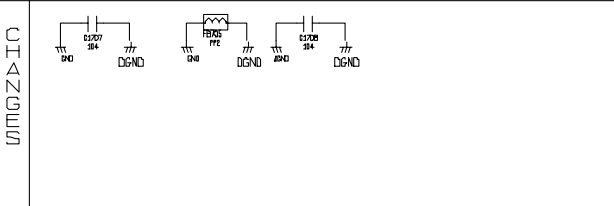

LM -U1350/1050

• MIC SCHEMATIC DIAGRAM

A

B

C

D

E

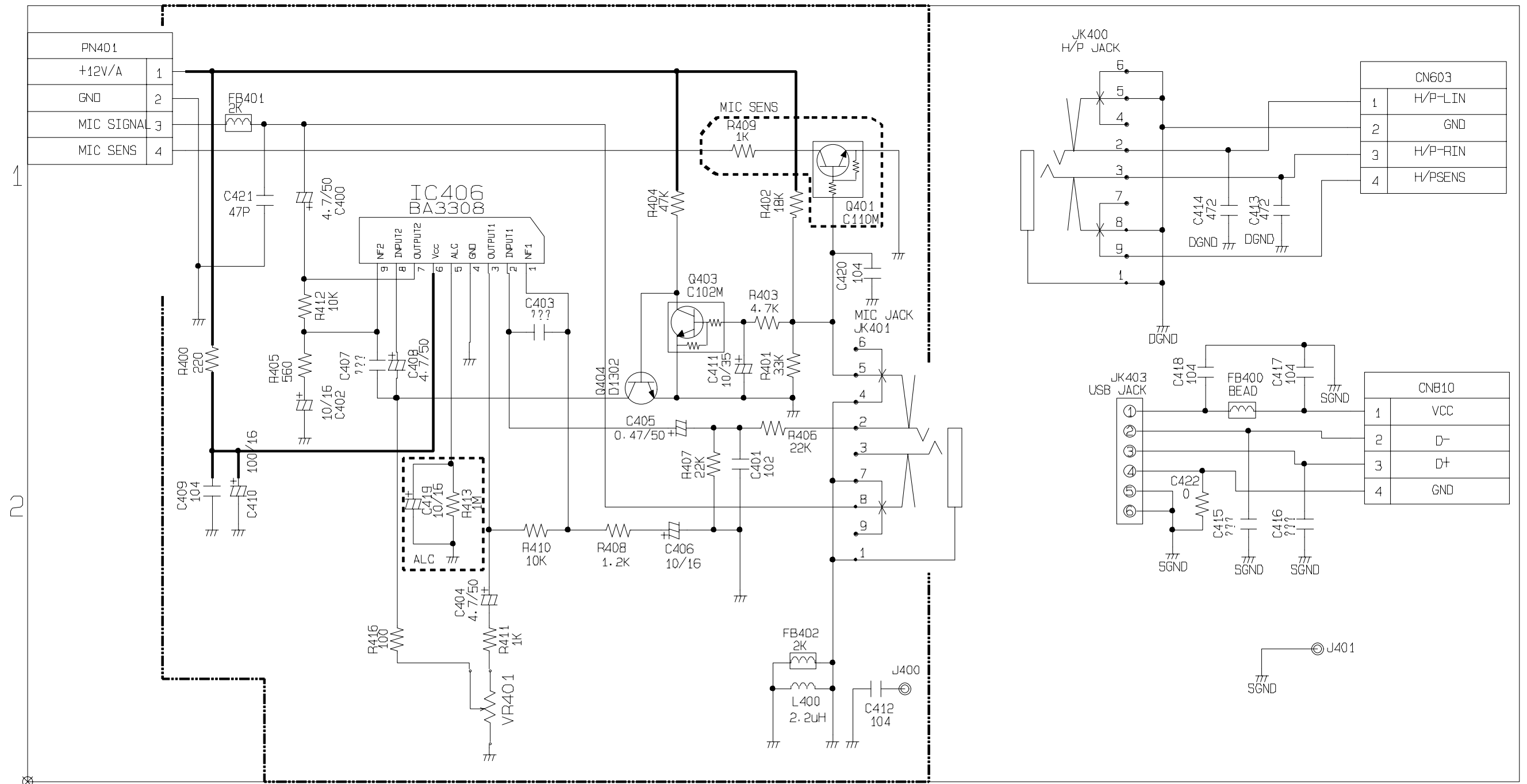

WIRING DIAGRAM

3CD CHANGER MECHANISM ASSY

LM-U1350 WIRING DIAGRAM

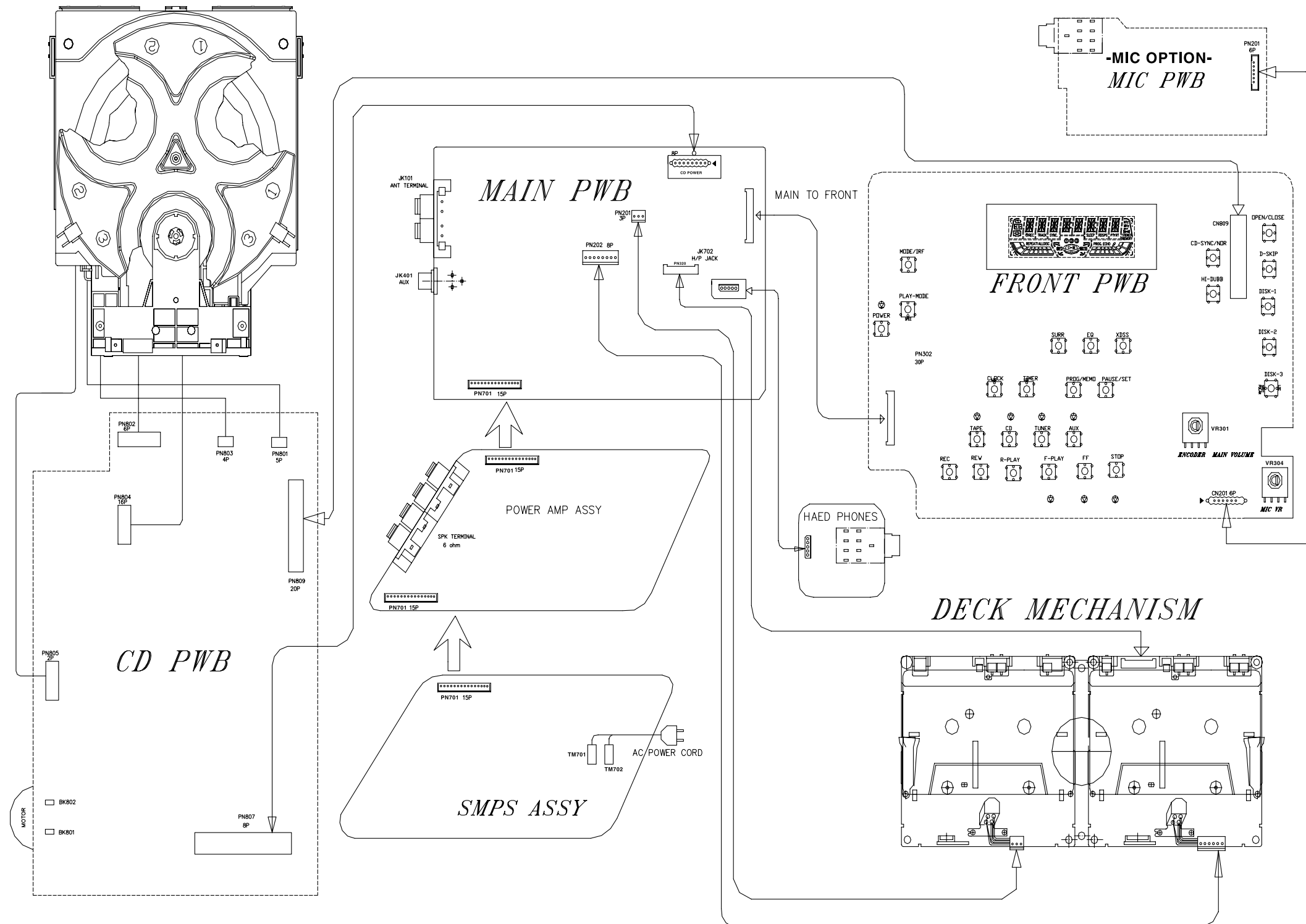

*KEC TR.

NAME	R1	R2	NAME	R1	R2
C102M	10K	10K	C111M	10K	
C103M	22K	22K			
C104M	47K	47K			
C110M	4.7K				

PRINTED CIRCUIT DIAGRAMS

MAIN P.C. BOARD (SOLDER SIDE)

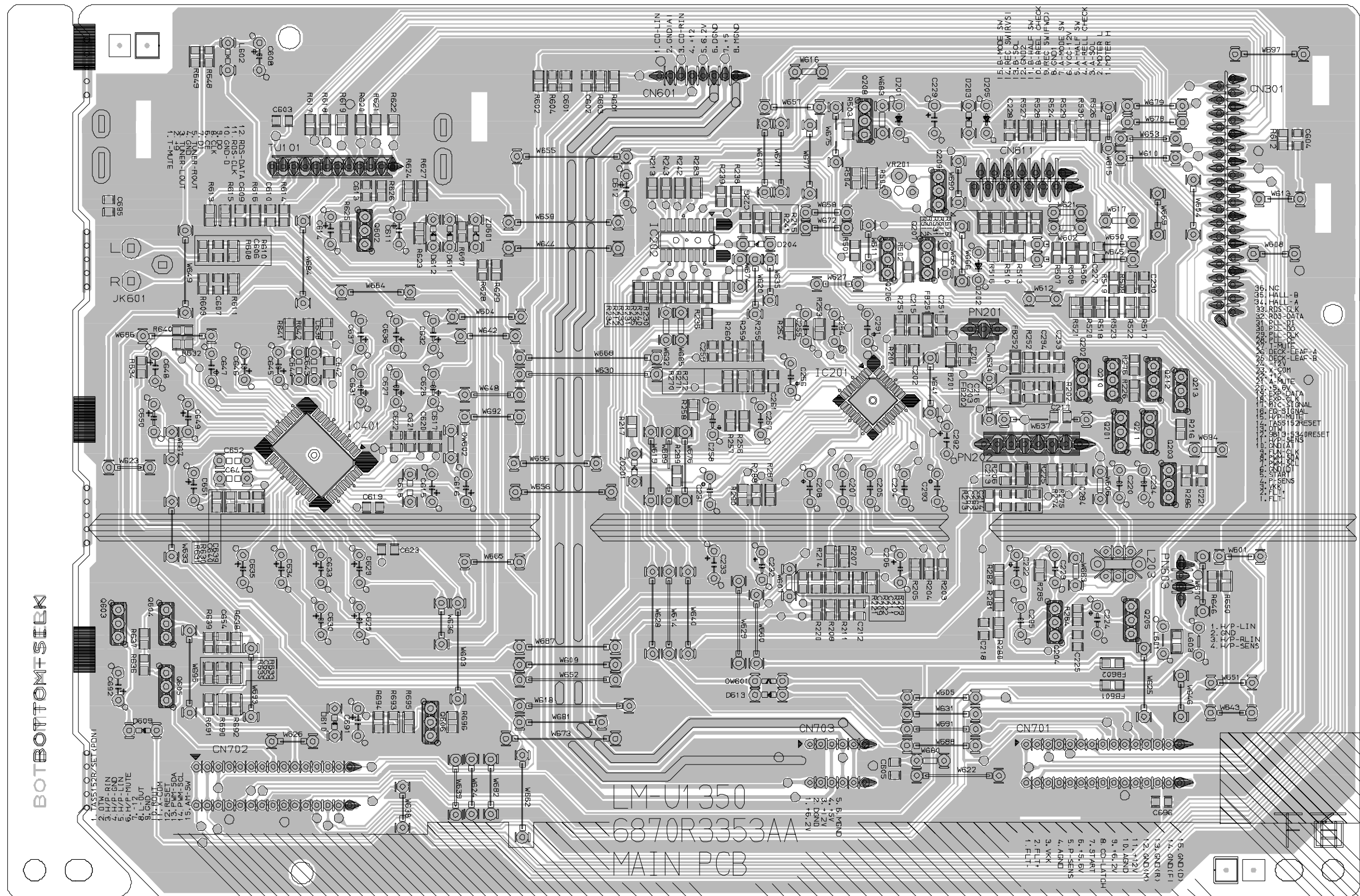

• MAIN P.C. BOARD (COMPONENT SIDE)

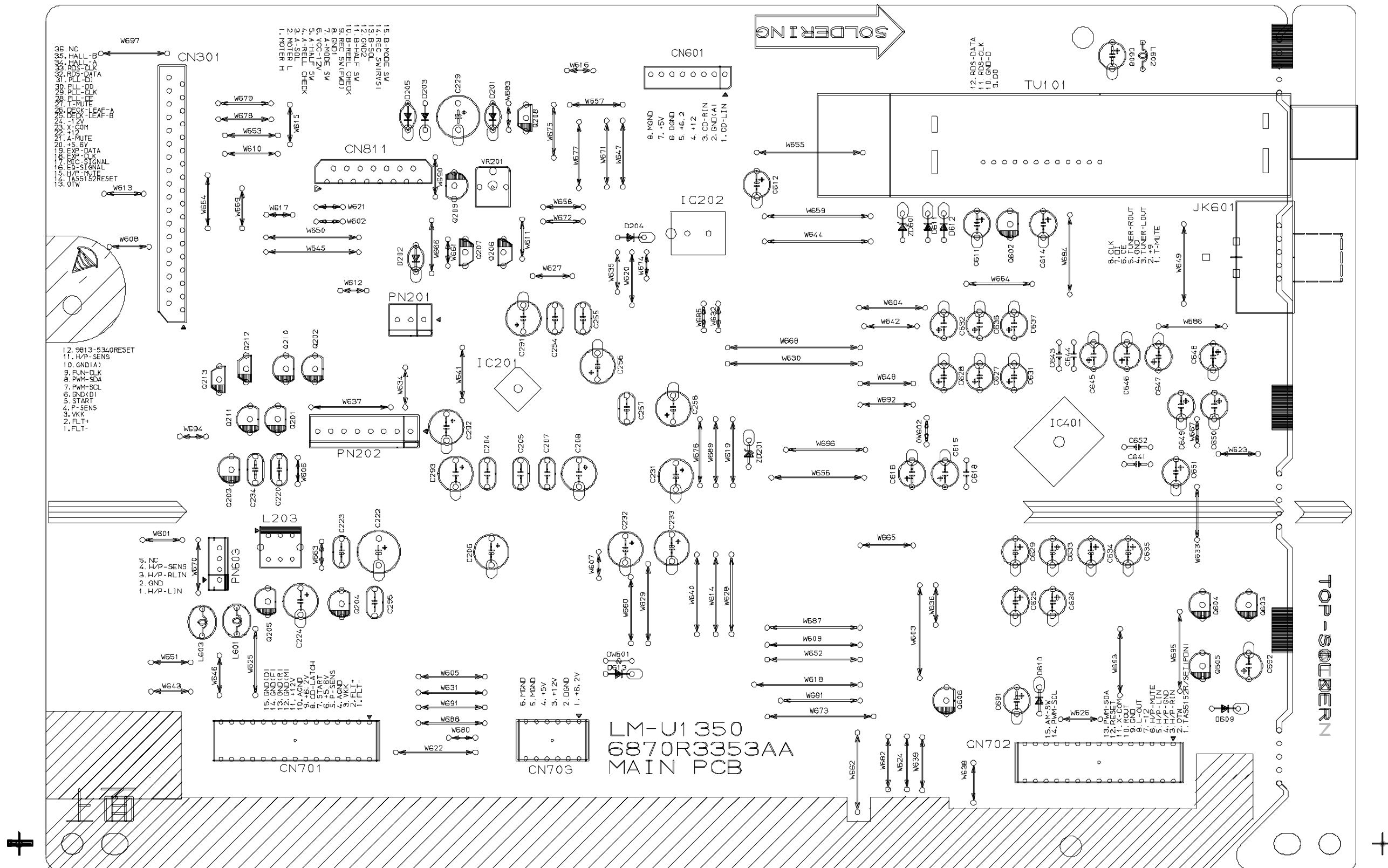

• FRONT P.C. BOARD(COMPONENT SIDE)

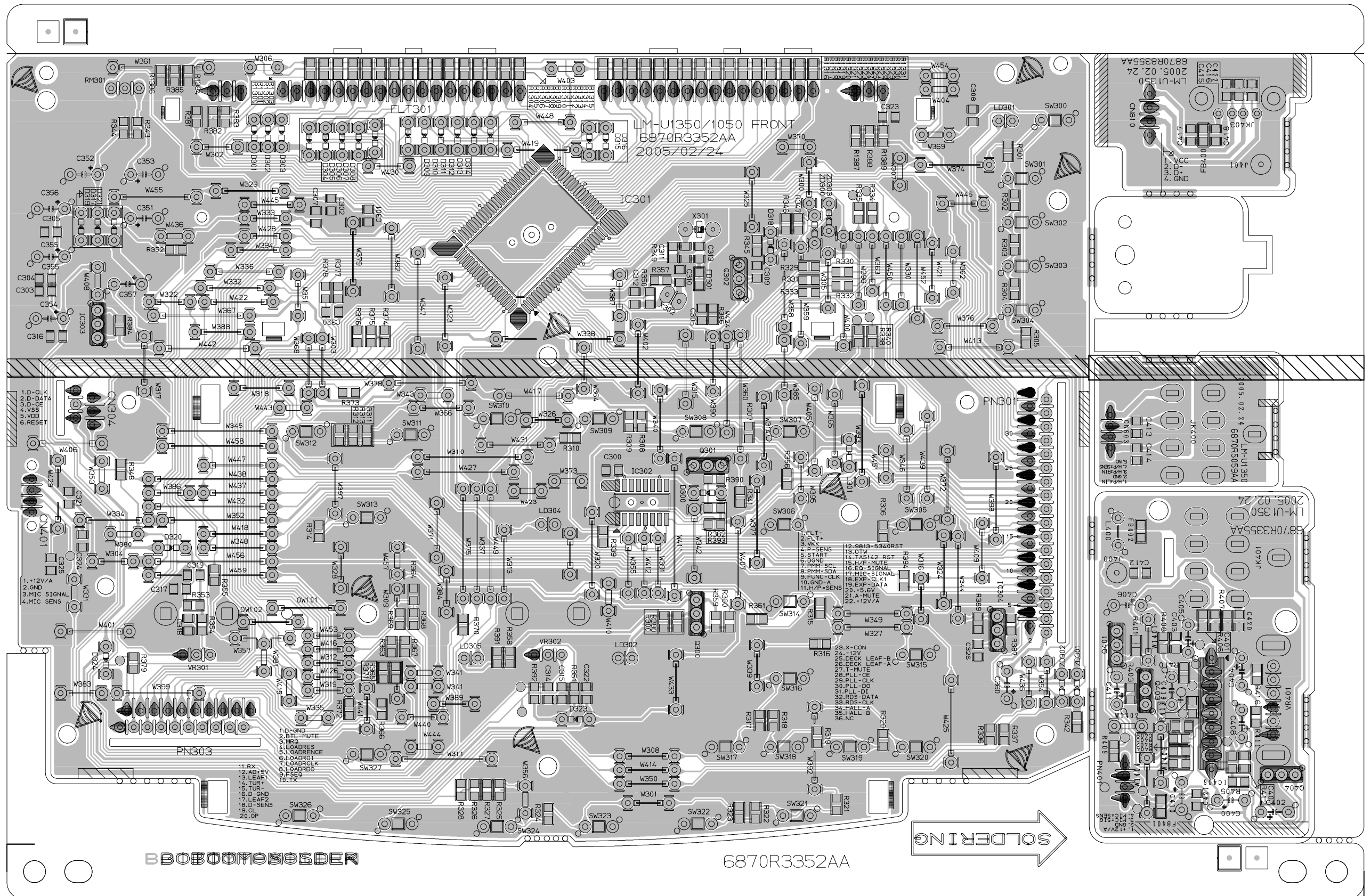

• FRONT P.C. BOARD(SOLDER SIDE)

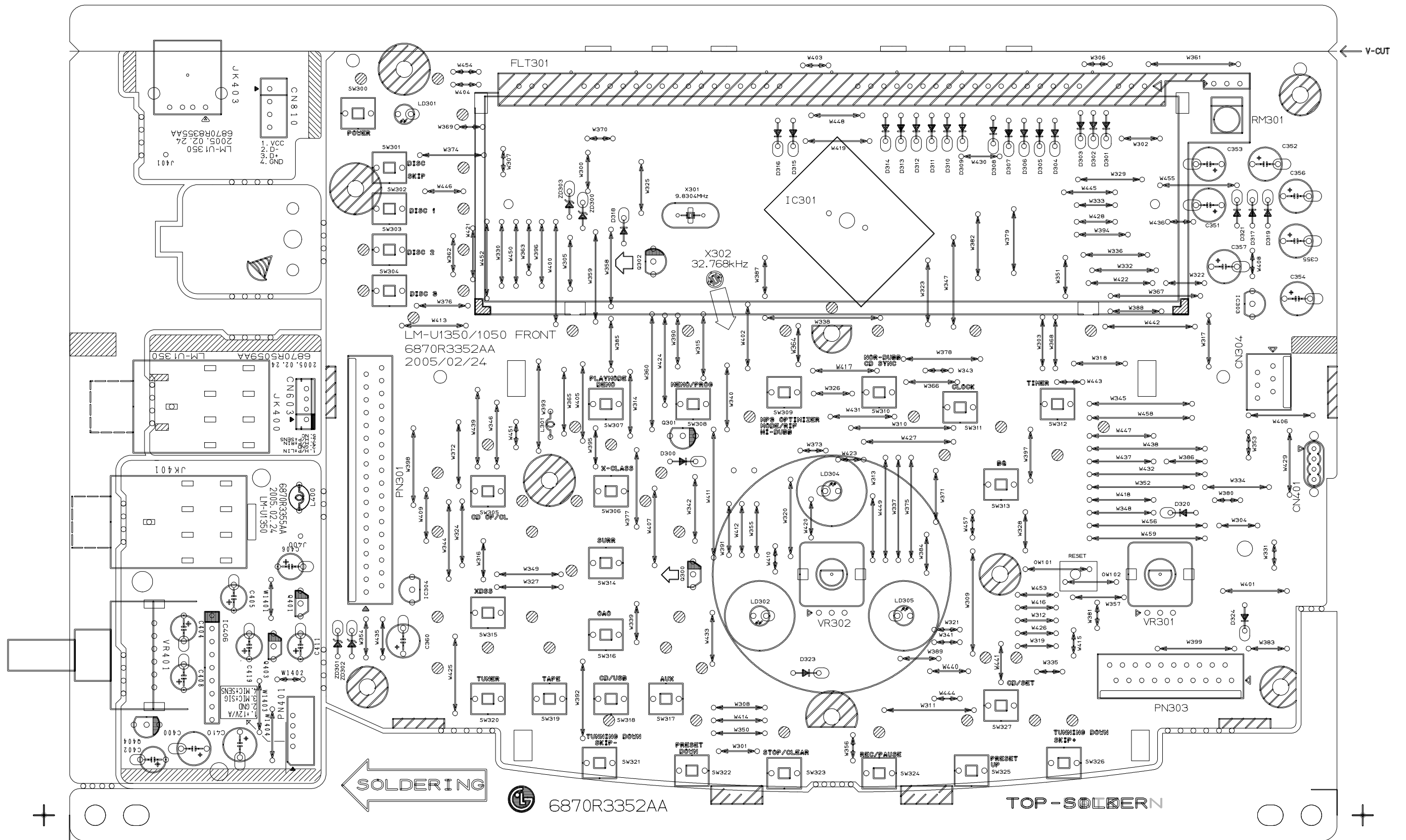

• CDP P.C. BOARD (COMPONENT SIDE)

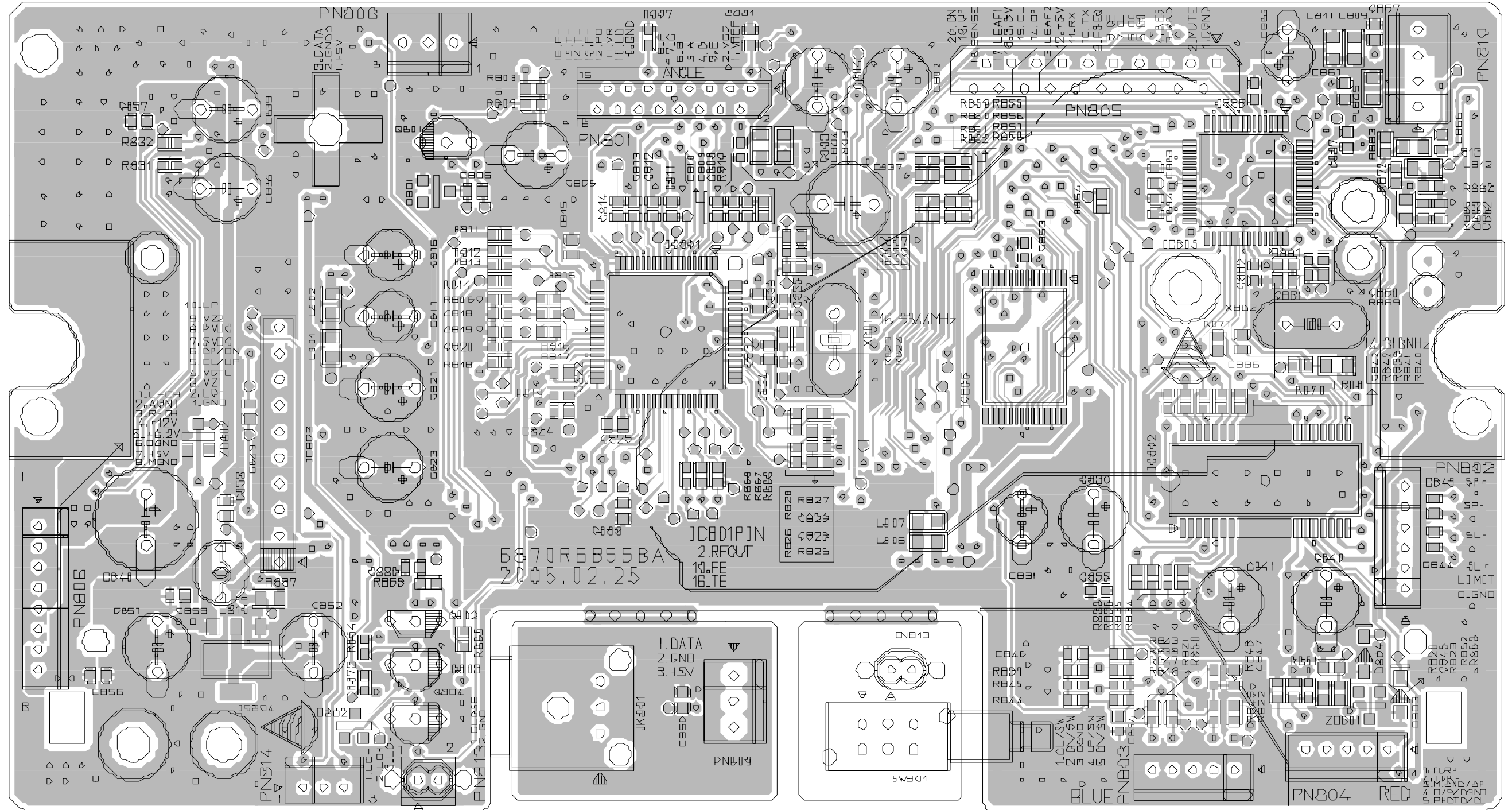

• CDP P.C. BOARD (SOLDER SIDE)

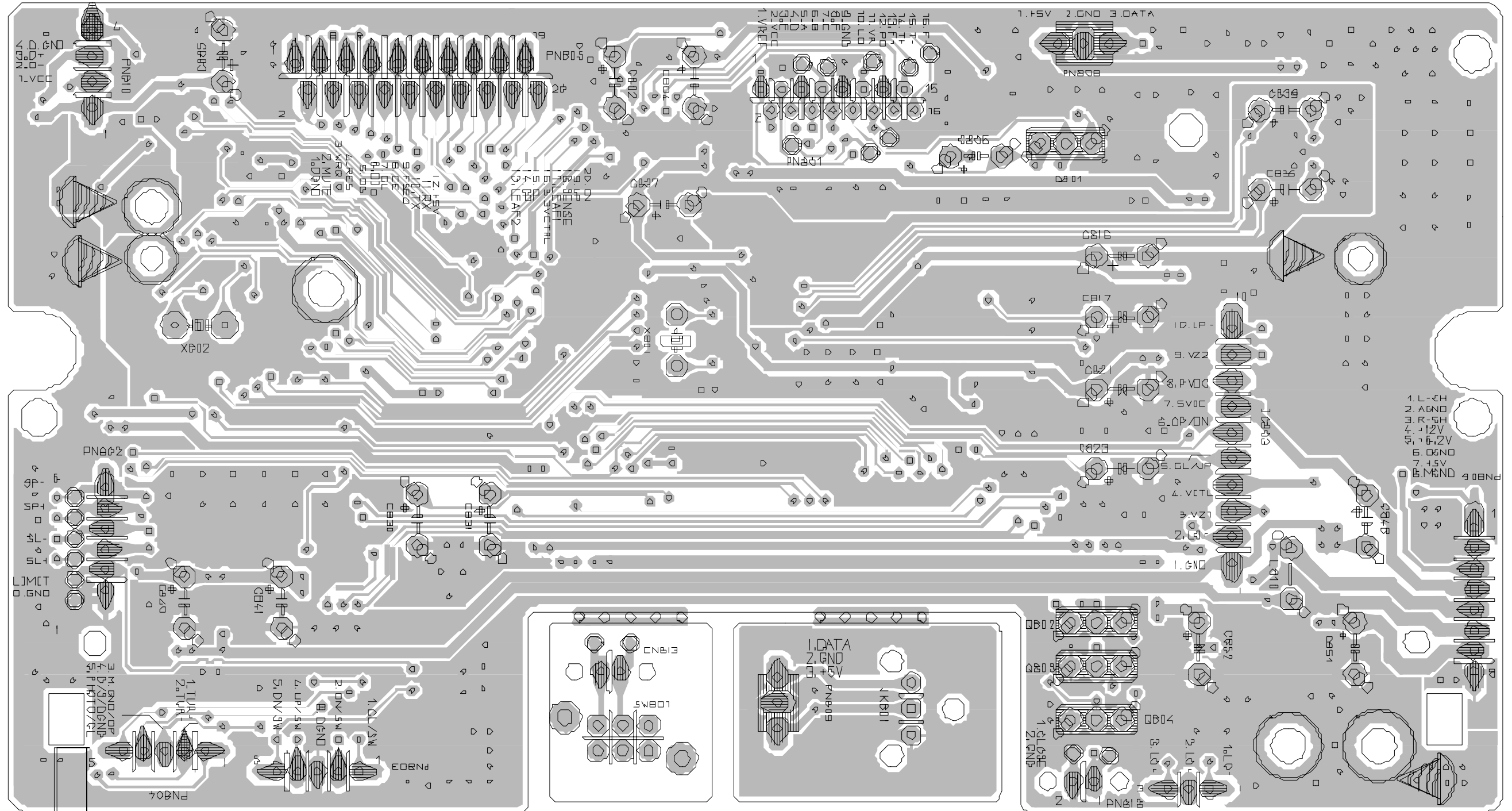

• AMP P.C. BOARD (SOLDER SIDE)

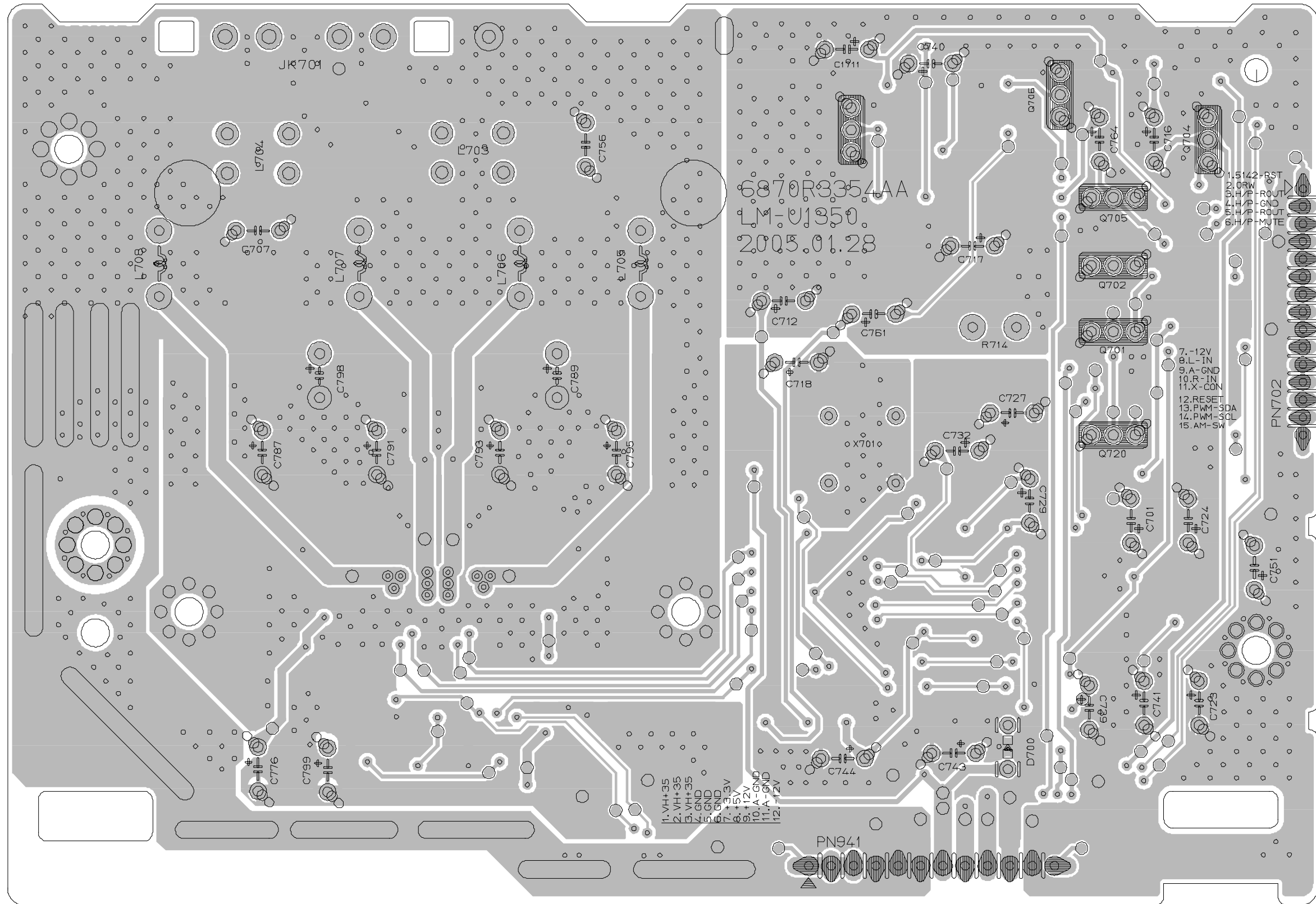

• AMP P.C. BOARD (COMPONENT SIDE)

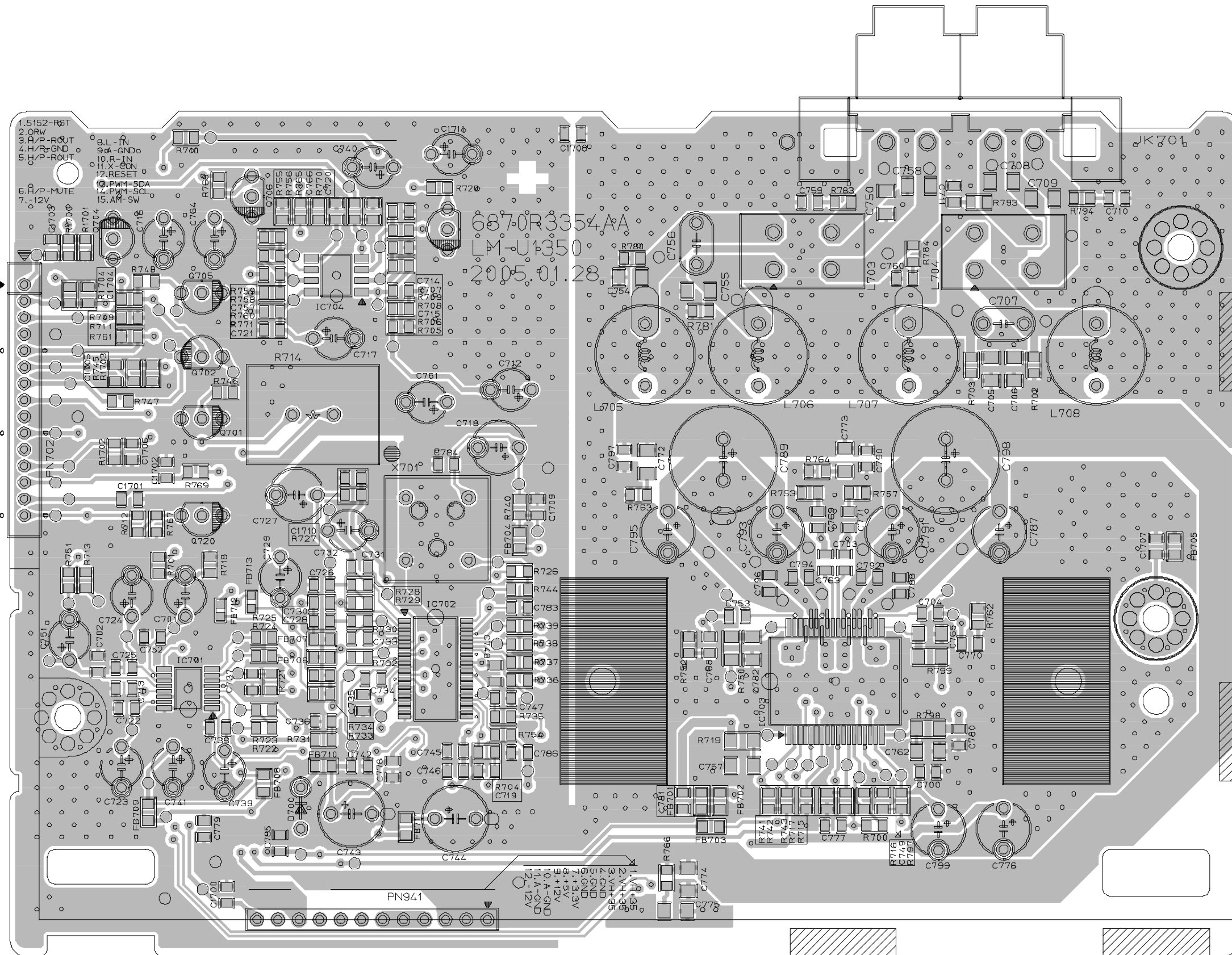

• TAPE DECK MECHANISM (A/R & A/S : RIGHT A/R DECK)

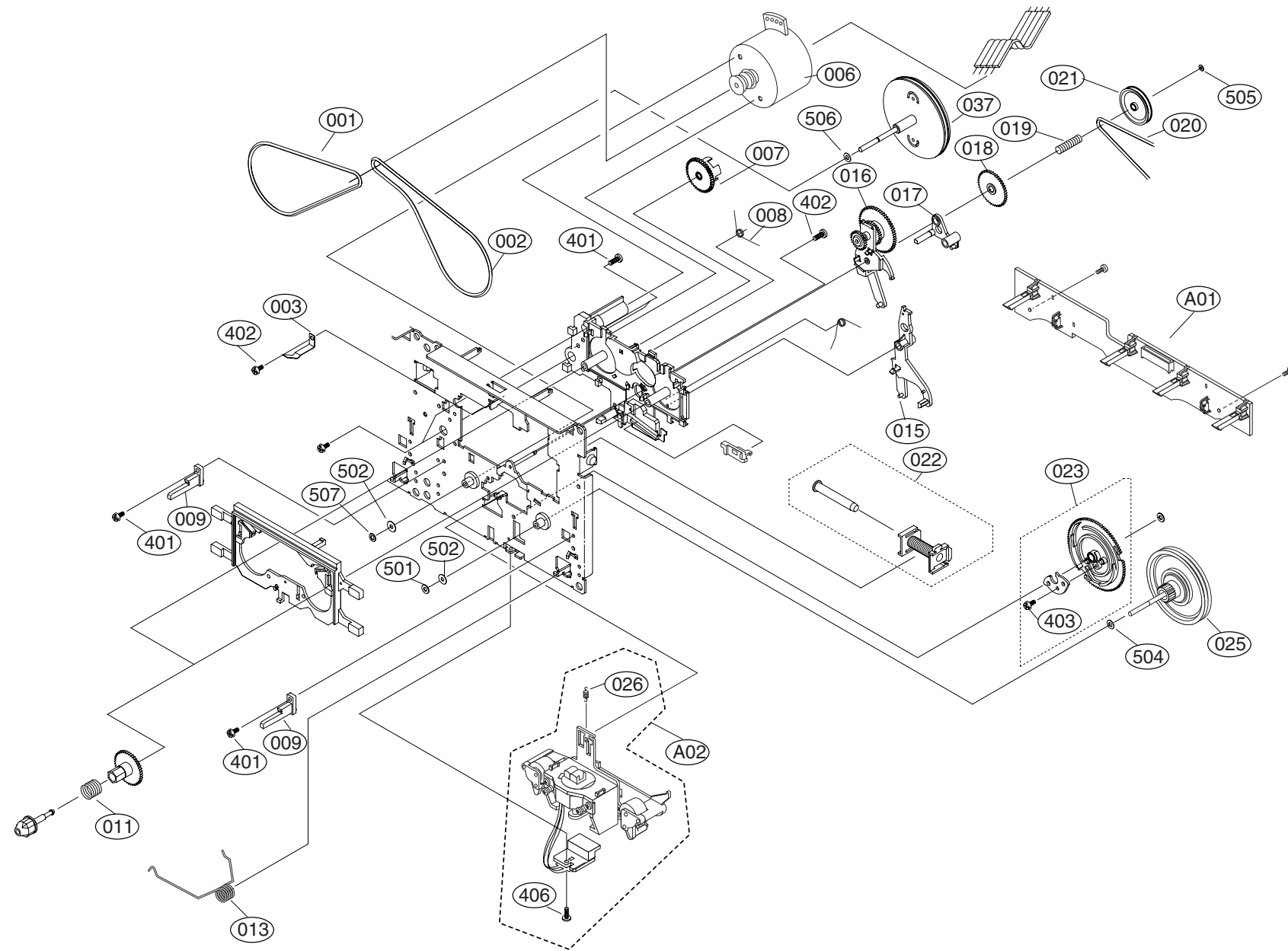

LOCA. NO.	LG PART NO.	DESCRIPTION	SPECIFICATION
A00	6720AG0008A	DECK,AUDIO	CWN42FR04 TOKYO PIGEON L-DOUBL
A01	6768R-UP04A	DECK MECHANISM PARTS	50-093-41285 PIGEON UNIT
A02	6768R-EP05A	DECK MECHANISM PARTS	50-093-41234 PIGEON HEAD ASSY
001	6768R-BP03D	DECK MECHANISM PARTS	02-083-4254 PIGEON BELT/FELT C
002	6768R-BP03E	DECK MECHANISM PARTS	02-083-4256 PIGEON BELT/FELT C
003	6768R-PP03A	DECK MECHANISM PARTS	33-160-4309 PIGEON PRESS CASSE
006	6768R-QP04A	DECK MECHANISM PARTS	50-093-41299 PIGEON MOTOR(ASSY
007	6768R-GP03B	DECK MECHANISM PARTS	50-222-4578 PIGEON GEAR IDLER
008	6768R-SP01F	DECK MECHANISM PARTS	01-082-4598 PIGEON SPRING CWL4
009	6768R-MP01C	DECK MECHANISM PARTS	50-219-4014 PIGEON MOLD CWL44
011	6768R-SP01A	DECK MECHANISM PARTS	01-081-4601 PIGEON SPRING CWL4
013	6768R-SP03A	DECK MECHANISM PARTS	01-082-4686 PIGEON SPRING CRM4
015	6768R-AP01A	DECK MECHANISM PARTS	50-268-3016 PIGEON ARM CWL44
016	6768R-GP01H	DECK MECHANISM PARTS	50-093-4503 PIGEON GEAR CRL442
017	6768R-AP01C	DECK MECHANISM PARTS	50-239-4072 PIGEON ARM CWL44
018	6768R-GP01J	DECK MECHANISM PARTS	50-222-4428 PIGEON GEAR CRL442
019	6768R-SP01P	DECK MECHANISM PARTS	01-081-4678 PIGEON SPRING CRL4
020	6768R-BP01C	DECK MECHANISM PARTS	02-083-4188 PIGEON BELT/FELT C
021	6768R-LP01C	DECK MECHANISM PARTS	50-223-4429 PIGEON PULLEY/FLYW
022	6768R-VP03A	DECK MECHANISM PARTS	50-093-4748 PIGEON SOLENOID AS
023	6768R-GP03A	DECK MECHANISM PARTS	50-093-4810 PIGEON GEAR ASSY C
025	6768R-JP03B	DECK MECHANISM PARTS	50-093-31009 PIGEON PULLEY/FLY
037	6768R-JP03A	DECK MECHANISM PARTS	50-093-4674 PIGEON PULLEY/FLYW
401	6768R-CP01B	DECK MECHANISM PARTS	GSE20A2005 PIGEON SCREW CWL44
402	6768R-CP01A	DECK MECHANISM PARTS	GSE10A2003 PIGEON SCREW CWL44
403	6768R-CP01D	DECK MECHANISM PARTS	GSL10A1704 PIGEON SCREW CWL44
407	6768R-CP01H	DECK MECHANISM PARTS	GSL20A2005 PIGEON SCREW CWL44
408	6768R-CP01J	DECK MECHANISM PARTS	03-300-4127 PIGEON SCREW CWL44
501	6768R-WP03A	DECK MECHANISM PARTS	GWN19S035040 PIGEON WASHER CRM
502	6768R-WP03B	DECK MECHANISM PARTS	03-000-4532 PIGEON WASHER CRM4
504	6768R-WP01D	DECK MECHANISM PARTS	GWP21X045020 PIGEON WASHER CWL
505	6768R-WP01E	DECK MECHANISM PARTS	GWP12X030040S PIGEON WASHER CW
506	6768R-WP01H	DECK MECHANISM PARTS	GWP23X040020 PIGEON WASHER CWL
507	6768R-WP01F	DECK MECHANISM PARTS	GWN21X040040 PIGEON WASHER CWL

• TAPE DECK MECHANISM (A/R & A/S : LEFT A/S DECK)

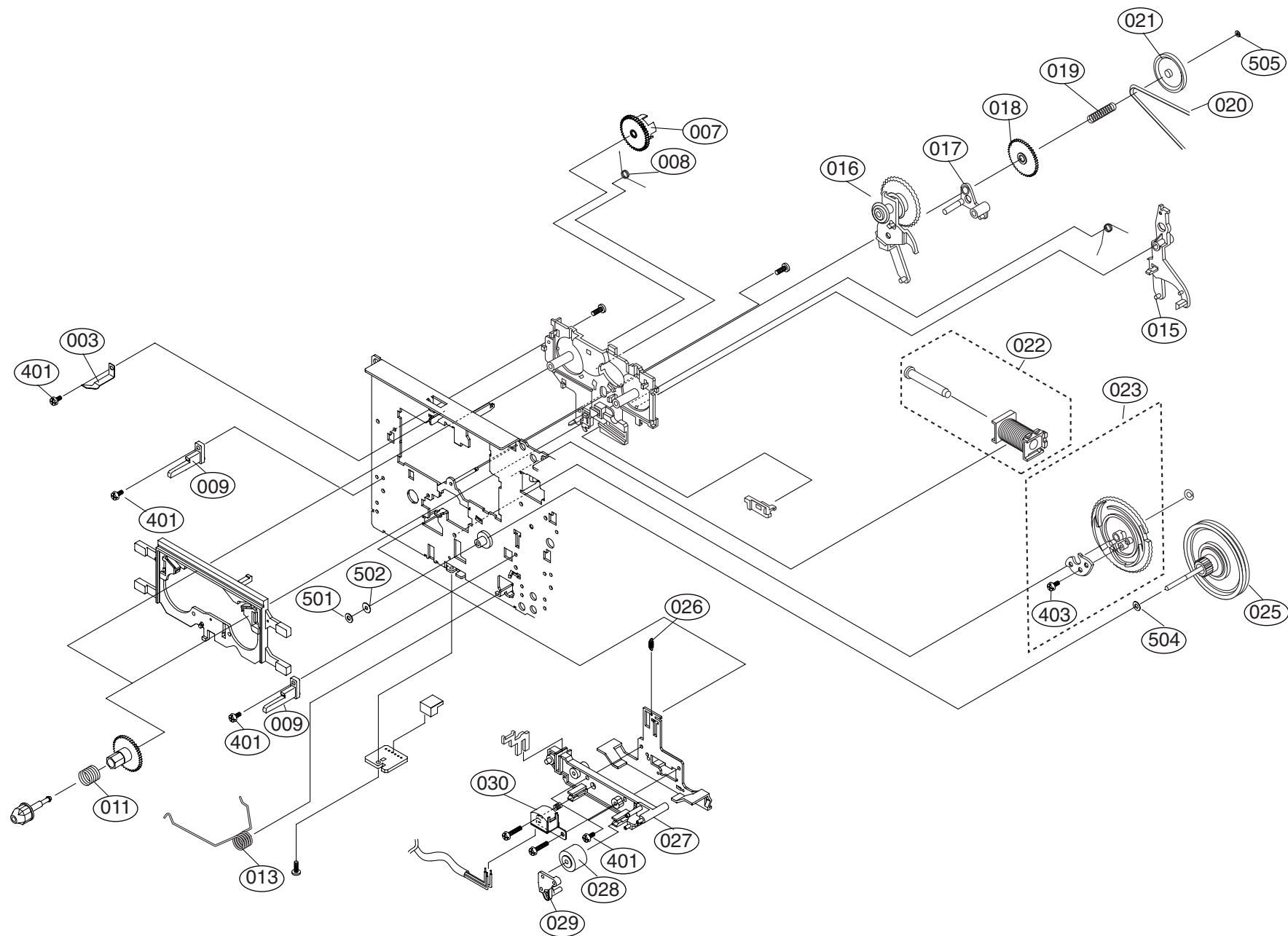

LOCA. NO.	LG PART NO.	DESCRIPTION	SPECIFICATION
A00	6720AG0008A	DECK,AUDIO	CWM42FR47 TOKYO PIGEON L-DOUBL
003	6768R-PP03A	DECK MECHANISM PARTS	33-160-4309 PIGEON PRESS CASSE
007	6768R-GP03B	DECK MECHANISM PARTS	50-222-4578 PIGEON GEAR IDLER
008	6768R-SP01F	DECK MECHANISM PARTS	01-082-4598 PIGEON SPRING CWL4
009	6768R-MP01C	DECK MECHANISM PARTS	50-219-4014 PIGEON MOLD CWL44
011	6768R-SP01A	DECK MECHANISM PARTS	01-081-4601 PIGEON SPRING CWL4
013	6768R-SP03A	DECK MECHANISM PARTS	01-082-4686 PIGEON SPRING CRM4
015	6768R-AP01A	DECK MECHANISM PARTS	50-268-3016 PIGEON ARM CWL44
016	6768R-GP01H	DECK MECHANISM PARTS	50-093-4503 PIGEON GEAR CRL442
017	6768R-AP01C	DECK MECHANISM PARTS	50-239-4072 PIGEON ARM CWL44
018	6768R-GP01J	DECK MECHANISM PARTS	50-222-4428 PIGEON GEAR CRL442
019	6768R-SP01P	DECK MECHANISM PARTS	01-081-4678 PIGEON SPRING CRL4
020	6768R-BP01C	DECK MECHANISM PARTS	02-083-4188 PIGEON BELT/FELT C
021	6768R-LP01C	DECK MECHANISM PARTS	50-223-4429 PIGEON PULLEY/FLYW
022	6768R-VP03A	DECK MECHANISM PARTS	50-093-4748 PIGEON SOLENOID AS
023	6768R-GP03A	DECK MECHANISM PARTS	50-093-4810 PIGEON GEAR ASSY C
025	6768R-JP03B	DECK MECHANISM PARTS	50-093-31009 PIGEON PULLEY/FLY
026	6768R-SP01D	DECK MECHANISM PARTS	01-080-4609 PIGEON SPRING CWL4
027	6768R-DP01A	DECK MECHANISM PARTS	50-259-3342 PIGEON LEVER CWL44
028	6768R-RP01A	DECK MECHANISM PARTS	22-027-41054 PIGEON ROLLER CWL
029	6768R-MP01A	DECK MECHANISM PARTS	50-219-4033 PIGEON MOLD CWL44
030	6768R-EP03C	DECK MECHANISM PARTS	T21V0P PIGEON HEAD CWM42FF30
401	6768R-CP01B	DECK MECHANISM PARTS	GSE20A2005 PIGEON SCREW CWL44
403	6768R-CP01D	DECK MECHANISM PARTS	GSL10A1704 PIGEON SCREW CWL44
501	6768R-WP03A	DECK MECHANISM PARTS	GWN19S035040 PIGEON WASHER CRM
502	6768R-WP03B	DECK MECHANISM PARTS	03-000-4532 PIGEON WASHER CRM4
504	6768R-WP01D	DECK MECHANISM PARTS	GWP21X045020 PIGEON WASHER CWL
505	6768R-WP01E	DECK MECHANISM PARTS	GWP12X030040S PIGEON WASHER CW

• CD MECHANISM

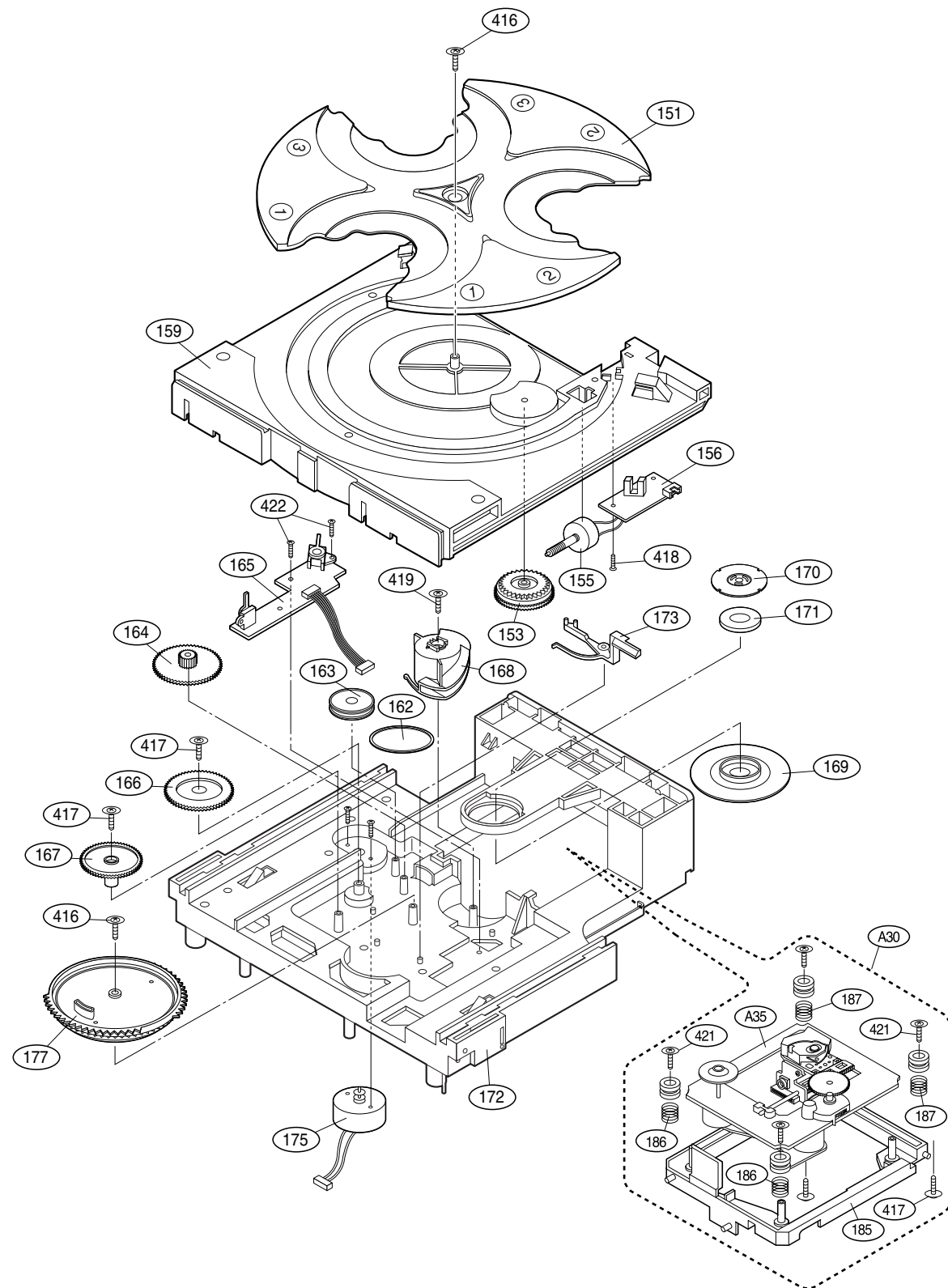

LOCA. NO.	LG PART NO.	DESCRIPTION	SPECIFICATION
A26	4405R-E008B	MECHANISM ASSEMBLY	LM-U1050/U1350 MP3 CD PWB + H1
A30	3041RB0002C	BASE ASSEMBLY	PU(SPRING DAMPER)
A35	6717RCA001B	PICK UP ASSEMBLY	KSM-213VLCM SONY FRONT LOADING
151	3390RB0002A	TRAY	DISC(CDM-H1503)
153	4470RB0005A	GEAR	TRAY (CDM-H1503)
155	4681RBA001B	MOTOR ASSEMBLY	HOME TRAY (CDM-H1503) MABUCHI
156	6871RF9211A	PWB(PCB) ASSEMBLY,FRONT	1503 T/D SENSOR
159	3390RB0001A	TRAY	LOADING(CDM-H1503)
162	4400R-0012A	BELT	DECK/MECHA MAIN CDM-H1503V OTH
163	4470R-0190A	GEAR	DECK/MECHA PULLEY CDM-H1503V M
164	4470RB0003A	GEAR	LOADING (CDM-H1503)
166	4470RB0006A	GEAR	PU UP (CDM-H1503)
167	4470RB0007A	GEAR	PU DOWN (CDM-H1503)
168	4470RB0002A	GEAR	CAM (CDM-H1503)
169	4860RB0002B	CLAMP	HOME CDM-H1503 MOLD CLAMP ASSY
172	3040RB0005A	BASE	MAIN (CDM-H1503)
173	4510RB0001A	LEVER	S/W CLOSE
175	4681RBA002A	MOTOR ASSEMBLY	HOME LOADING (PULLEY 8.6)
177	4470RB0001A	GEAR	MAIN (CDM-H1503)
184	4900RB0002A	DAMPER	HOME 3CD CHANGER MOLD RUBBER
185	3040SB0003A	BASE	PU(CDM-H1303)
186	4970RB0001A	SPRING	COIL 3 CD CHANGER
187	4970RB0001B	SPRING	COIL 50 3CD CHANGER
416	88H-0004	CD MECHA PARTS	3X12X12FNM
417	88H-0002	CD MECHA PARTS	3X9X12FZMY
418	353-025BAAA	SCREW,DRAWING	#NAME?
419	88H-0003	CD MECHA PARTS	3X12X10FZMY
420	353S353F	SCREW,DRAWING	#NAME?
421	6756SBX001A	CD MECHANISM PARTS	SCREW 2.6X10X10XFZMY CDM-H813
422	353-028H	SCREW	#NAME?

SECTION 4. SPEAKER SECTION

MODEL: LMS-U1050

