



P/N : 3829RAP006B

JULY, 2005

LG Electronics Inc.

SERVICE MANUAL MODEL: LM-U2350A, LMS-U2350, LM-U4050A, LMS-U4050, LMS-U4050W, LM-U5050A, LMS-U5050, LMS-U5050W, LMS-U5050S



3CD CHANGER HI-FI SYSTEM **SERVICE MANUAL**

CAUTION

BEFORE SERVICING THE UNIT, READ THE "SAFETY PRECAUTIONS" IN THIS MANUAL.

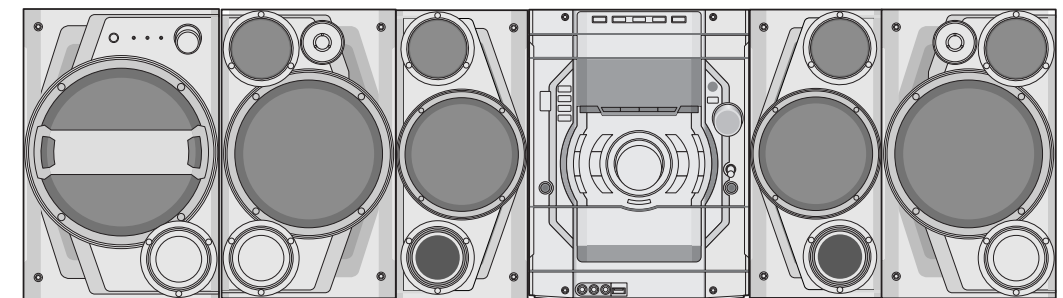

**MODEL: LM-U2350A, LMS-U2350
LM-U4050A, LMS-U4050, LMS-U4050W
LM-U5050A, LMS-U5050, LMS-U5050W, LMS-U5050S**

[CONTENTS]

○ SECTION 1. GENERAL

- SERVICING PRECAUTIONS 1-2
- ESD PRECAUTIONS 1-4
- SPECIFICATION 1-5

○ SECTION 2. ELECTRICAL SECTION

- ELECTRICAL TROUBLESHOOTING GUIDE 2-1
- INTERNAL BLOCK DIAGRAM of ICs 2-10
- BLOCK DIAGRAM 2-15
- SCHEMATIC DIAGRAMS 2-19
- WIREING DIAGRAM 2-43
- PRINTED CIRCUIT DIAGRAMS 2-45

○ SECTION 3. EXPLODED VIEWS

- CABINET AND MAIN FRAME SECTION 3-1
- TAPE DECK MECHANISM (A/R & A/S : RIGHT A/R DECK) 3-3
- TAPE DECK MECHANISM (A/R & A/S : LEFT A/S DECK) 3-5
- CD MECHANISM 3-7

○ SECTION 4. SPEAKER PART

- SPEAKER PART 4-1

○ SECTION 5. REPLACEMENT PARTS LIST

- REPLACEMENT PARTS LIST 5-1

SECTION 1. GENERAL

☐ SERVICING PRECAUTIONS

■ NOTES REGARDING HANDLING OF THE PICK-UP

1. Notes for transport and storage

- 1) The pick-up should always be left in its conductive bag until immediately prior to use.
- 2) The pick-up should never be subjected to external pressure or impact.

Storage in conductive bag

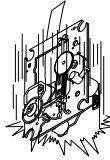
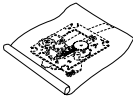

Drop impact

2. Repair notes

- 1) The pick-up incorporates a strong magnet, and so should never be brought close to magnetic materials.
- 2) The pick-up should always be handled correctly and carefully, taking care to avoid external pressure and impact. If it is subjected to strong pressure or impact, the result may be an operational malfunction and/or damage to the printed-circuit board.
- 3) Each and every pick-up is already individually adjusted to a high degree of precision, and for that reason the adjustment point and installation screws should absolutely never be touched.
- 4) Laser beams may damage the eyes!
Absolutely never permit laser beams to enter the eyes!
Also NEVER switch ON the power to the laser output part (lens, etc.) of the pick-up if it is damaged.

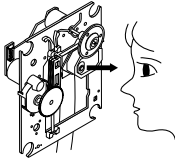

NEVER look directly at the laser beam, and don't let contact fingers or other exposed skin.

5) Cleaning the lens surface

If there is dust on the lens surface, the dust should be cleaned away by using an air bush (such as used for camera lens). The lens is held by a delicate spring. When cleaning the lens surface, therefore, a cotton swab should be used, taking care not to distort this.

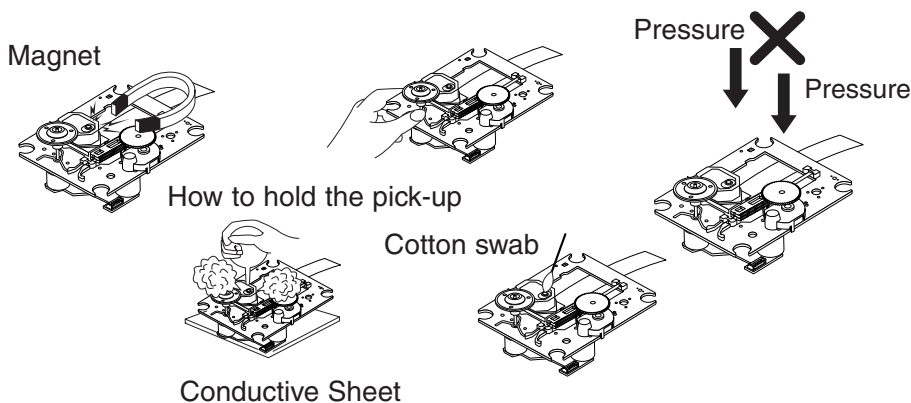

6) Never attempt to disassemble the pick-up.

Spring by excess pressure. If the lens is extremely dirty, apply isopropyl alcohol to the cotton swab. (Do not use any other liquid cleaners, because they will damage the lens.) Take care not to use too much of this alcohol on the swab, and do not allow the alcohol to get inside the pick-up.

■ NOTES REGARDING COMPACT DISC PLAYER REPAIRS

1. Preparations

- 1) Compact disc players incorporate a great many ICs as well as the pick-up (laser diode). These components are sensitive to, and easily affected by, static electricity. If such static electricity is high voltage, components can be damaged, and for that reason components should be handled with care.
- 2) The pick-up is composed of many optical components and other high-precision components. Care must be taken, therefore, to avoid repair or storage where the temperature of humidity is high, where strong magnetism is present, or where there is excessive dust.

2. Notes for repair

- 1) Before replacing a component part, first disconnect the power supply lead wire from the unit
- 2) All equipment, measuring instruments and tools must be grounded.
- 3) The workbench should be covered with a conductive sheet and grounded.
When removing the laser pick-up from its conductive bag, do not place the pick-up on the bag. (This is because there is the possibility of damage by static electricity.)
- 4) To prevent AC leakage, the metal part of the soldering iron should be grounded.
- 5) Workers should be grounded by an armband (1M Ω)
- 6) Care should be taken not to permit the laser pick-up to come in contact with clothing, in order to prevent static electricity changes in the clothing to escape from the armband.
- 7) The laser beam from the pick-up should NEVER be directly facing the eyes or bare skin.

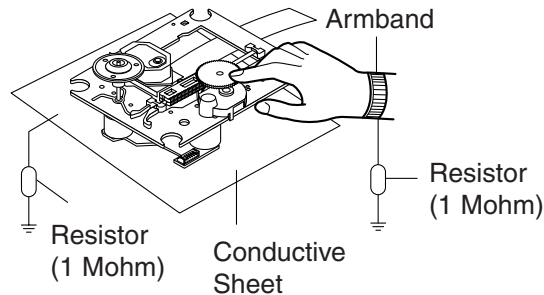

CLEARING MALFUNCTION

You can reset your unit to initial status if malfunction occur(button malfunction, display, etc.). Using a pointed good conductor(such as driver), simply short the RESET jump wire on the inside of the volume knob for more than 3 seconds.

If you reset your unit, you must reenter all its settings(stations, clock, timer)

- NOTE:** 1. To operate the RESET jump wire, pull the volume rotary knob and release it.
2. If you wish to operate the RESET jump wire, it is necessary to unplug the power cord.

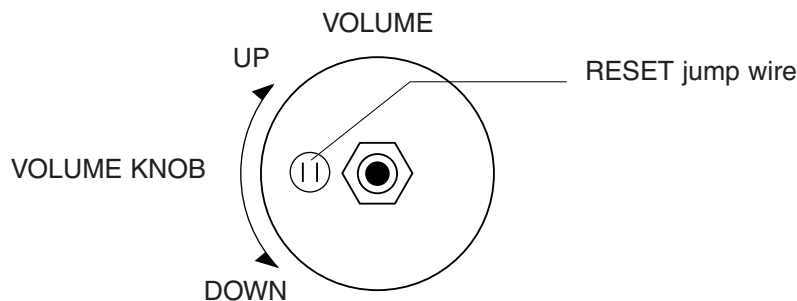

□ ESD PRECAUTIONS

■ Electrostatically Sensitive Devices (ESD)



Some semiconductor (solid state) devices can be damaged easily by static electricity. Such components commonly are called Electrostatically Sensitive Devices (ESD). Examples of typical ESD devices are integrated circuits and some field-effect transistors and semiconductor chip components. The following techniques should be used to help reduce the incidence of component damage caused by static electricity.

1. Immediately before handling any semiconductor component or semiconductor-equipped assembly, drain off any electrostatic charge on your body by touching a known earth ground. Alternatively, obtain and wear a commercially available discharging wrist strap device, which should be removed for potential shock reasons prior to applying power to the unit under test.
2. After removing an electrical assembly equipped with ESD devices, place the assembly on a conductive surface such as aluminum foil, to prevent electrostatic charge buildup or exposure of the assembly.
3. Use only a grounded-tip soldering iron to solder or unsolder ESD devices.
4. Use only an anti-static solder removal device. Some solder removal devices not classified as "anti-static" can generate electrical charges sufficient to damage ESD devices.
5. Do not use freon-propelled chemicals. These can generate electrical charges sufficient to damage ESD devices.
6. Do not remove a replacement ESD device from its protective package until immediately before you are ready to install it. (Most replacement ESD devices are packaged with leads electrically shorted together by conductive foam, aluminum foil or comparable conductive materials).
7. Immediately before removing the protective material from the leads of a replacement ESD device, touch the protective material to the chassis or circuit assembly into which the device will be installed.

CAUTION : BE SURE NO POWER IS APPLIED TO THE CHASSIS OR CIRCUIT, AND OBSERVE ALL OTHER SAFETY PRECAUTIONS.

8. Minimize bodily motions when handing unpackaged replacement ESD devices. (Otherwise harmless motion such as the brushing together of your clothes fabric or the lifting of your foot from a carpeted floor can generate static electricity sufficient to damage an ESD device).

CAUTION. GRAPHIC SYMBOLS

	THE LIGHTNING FLASH WITH APROWHEAD SYMBOL, WITHIN AN EQUILATERAL TRIANGLE, IS INTENDED TO ALERT THE SERVICE PERSONNEL TO THE PRESENCE OF UNINSULATED "DANGEROUS VOLTAGE" THAT MAY BE OF SUFFICIENT MAGNITUDE TO CONSTITUTE A RISK OF ELECTRIC SHOCK.
	THE EXCLAMATION POINT WITHIN AN EQUILATERAL TRIANGLE IS INTENDED TO ALERT THE SERVICE PERSONNEL TO THE PRESENCE OF IMPORTANT SAFETY INFORMATION IN SERVICE LITERATURE.

□ SPECIFICATIONS

SECTION		MODEL	LM-U5050	LM-U4050	LM-U2350
[General]	Power supply	Refer to the back panel of the unit.			
	Power consumption	200 W		110 W	
	Weight	8.5 kg			
	External dimensions (W x H x D)	280 x 370 x 400 mm			
[CD]	Frequency response	40 - 18000 Hz			
	Signal-to-noise ratio	75 dB			
	Dynamic range	70 dB			
[Tuner]	FM	Tuning Range	87.5 - 108.0 MHz or 65 - 74 MHz, 87.5 - 108.0 MHz		
		Intermediate Frequency	10.7 MHz		
		Signal to Noise Ratio	60/55 dB		
		Frequency Response	60 - 10000 Hz		
	AM (MW)	Tuning Range	522 - 1620 kHz or 520 - 1720 kHz		
		Intermediate Frequency	450 kHz		
		Signal to Noise Ratio	30 dB		
		Frequency Response	120 - 2000 Hz		
[Amp]	Output Power	Front : 270 W + 270 W (LM-U5050 model only) 250 W + 250 W (LM-U4050/U2350 model only) Surround : 110 W + 110 W (LM-U5050 model only) Subwoofer : 350 W (LM-U5050/U4050 model only)			
	T.H.D	0.7%			
	Frequency Response	42 - 20000 Hz			
	Signal-to-noise ratio	80 dB			
[TAPE]	Tape Speed	3000 ± 3 % (MTT-111. NORMAL-SPEED)			
	Wow Flutter	0.25 % (MTT -111, JIS-WTD)			
	F.F/REW Time	120 sec (C-60)			
	Frequency Response	125 - 8000 Hz			
	Signal to Noise Ratio	40 dB			
	Channel Separation	50 dB (P/B)/45 dB (R/P)			
	Erase Ratio	55dB (MTT-5511)			
[Speakers]	Speaker Name	Front speaker (L/R)		Surround speaker (L/R)	
		LMS-U5050	LMS-U4050/U2350	[LMS-U5050S]	
	Type	Bass Reflex 3Way 3 Speaker		Bass Reflex 2Way 2Speaker	
	Impedance	6Ω		24Ω	
	Frequency Response	55 - 20000 Hz		60 - 20000 Hz	
	Sound Pressure Level	86 dB/W (1m)		86 dB/W (1m)	
	Rated Input Power	270 W	250 W	110 W	
	Max. Input Power	540 W	500 W	220 W	
	Net Dimensions (W x H x D)	250 X 300 X 415 mm		187 X 258 X 415 mm	
Weight	9.3 kg		4.3 kg		
[Subwoofer]	Speaker Name	Subwoofer (LMS-U5050W/U4050W)			
	Type	1 Way 1 Speaker			
	Impedance	6Ω			
	Frequency Response	45 - 15000 Hz			
	Sound Pressure Level	84 dB/W (1m)			
	Rated Input Power	350 W			
	Max. Input Power	700 W			
	Net Dimensions (W x H x D)	279 X 320 X 415 mm			
Weight	10.0 kg				

SECTION 2. ELECTRICAL

□ ELECTRICAL TROUBLESHOOTING GUIDE

■ SMPS POWER CIRCUIT

P-SENS PART

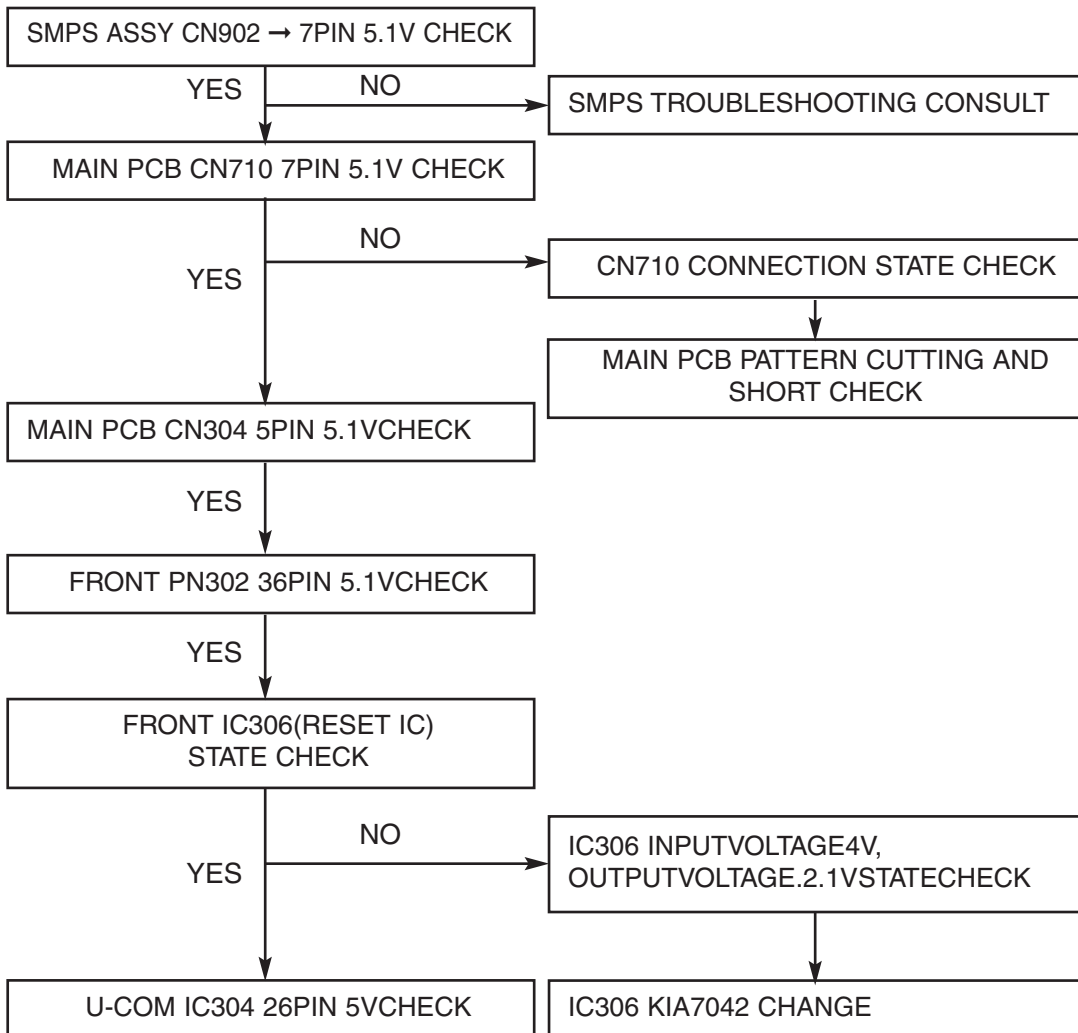

VKK CHECK

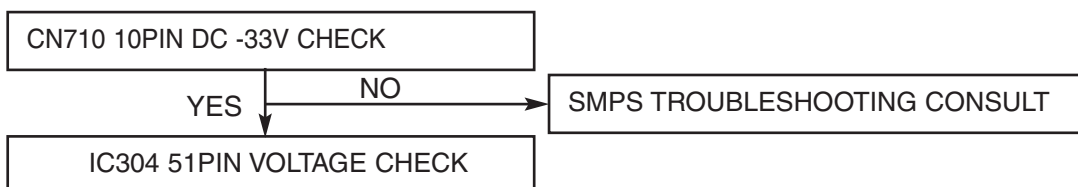

MICOM (IC301) CHECK

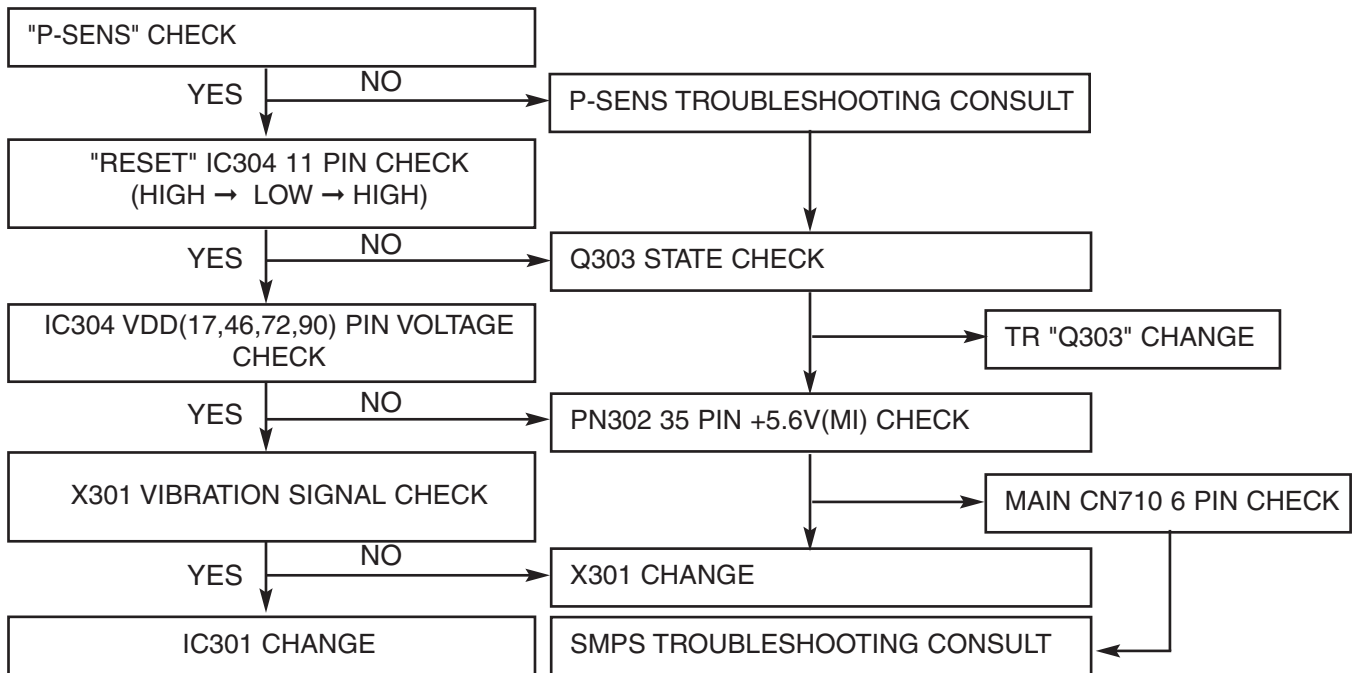

P-CTRL CHECK

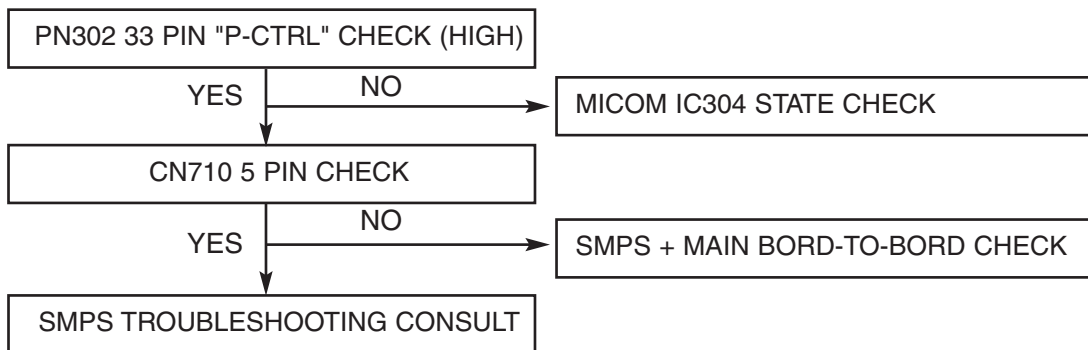

MUTING TROUBLESHOOTING (MUTE STATE)

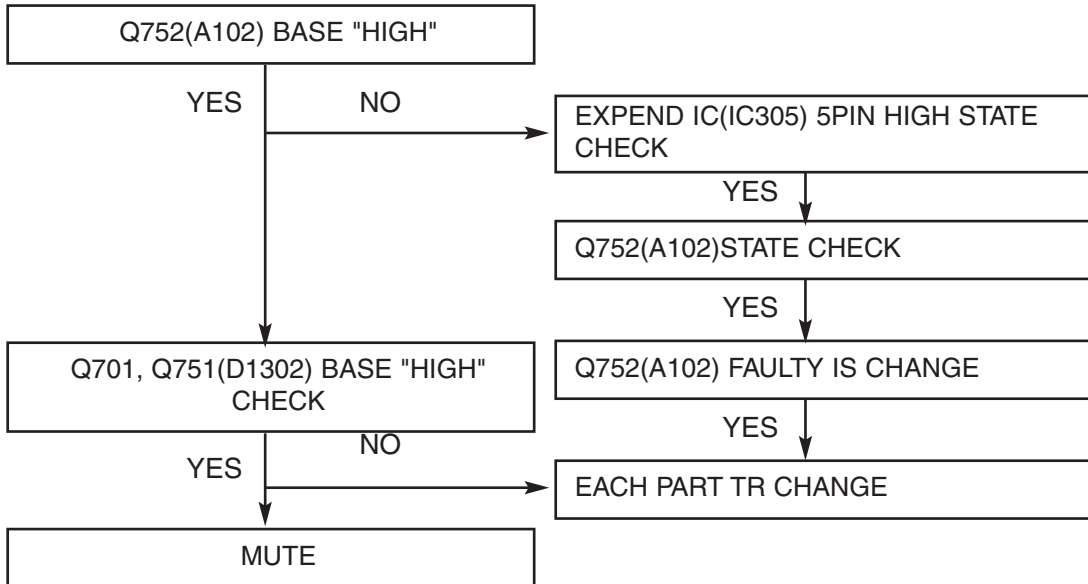

EXPEND IC(IC305/501/502) STATE

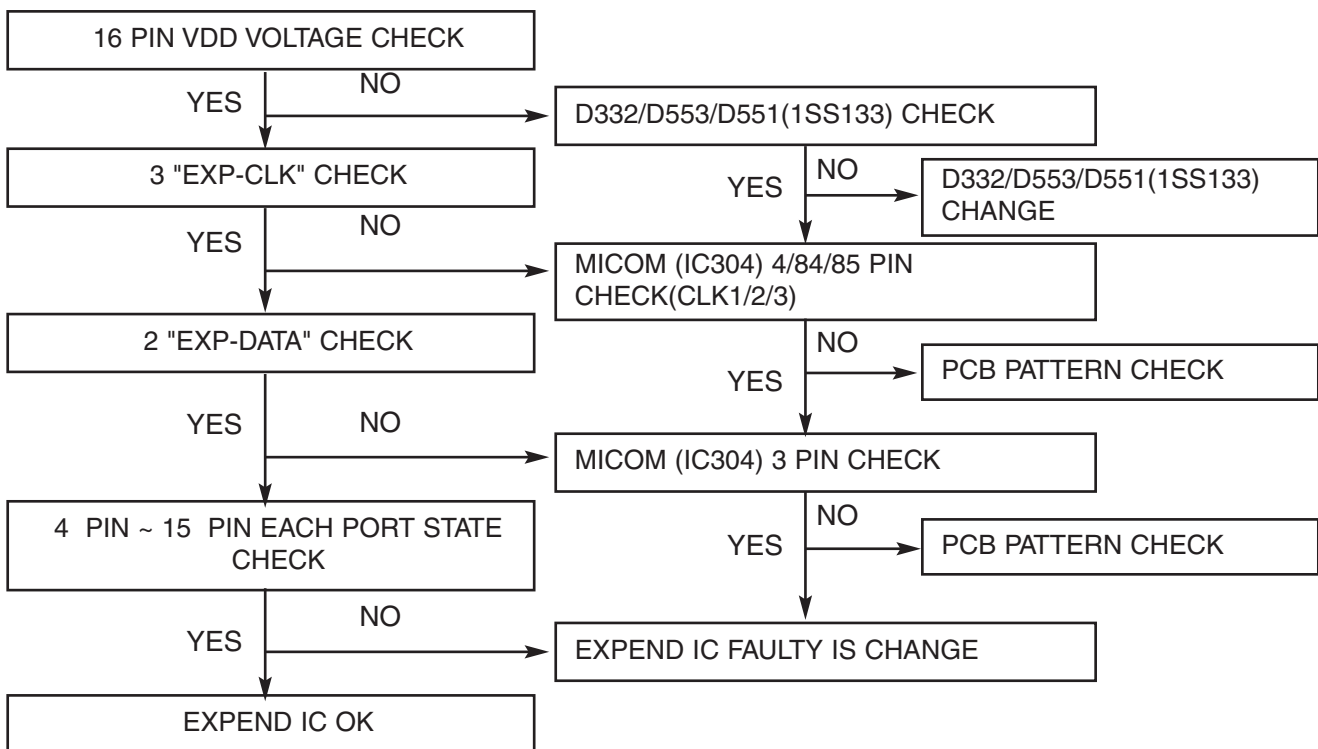

SPECIFIC FUNCTION MODE HAS NO SOUND (NJW1190) IC601

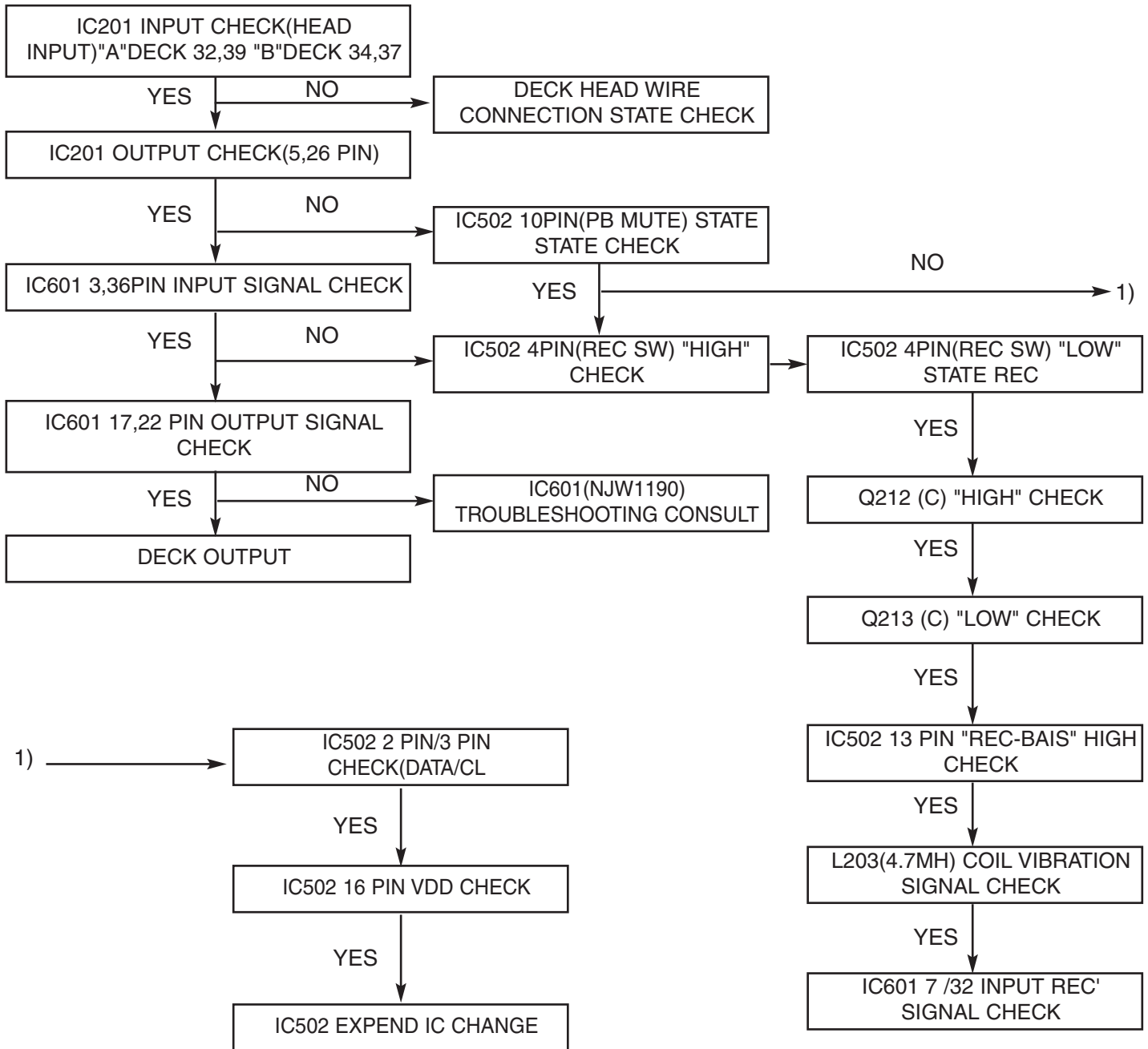

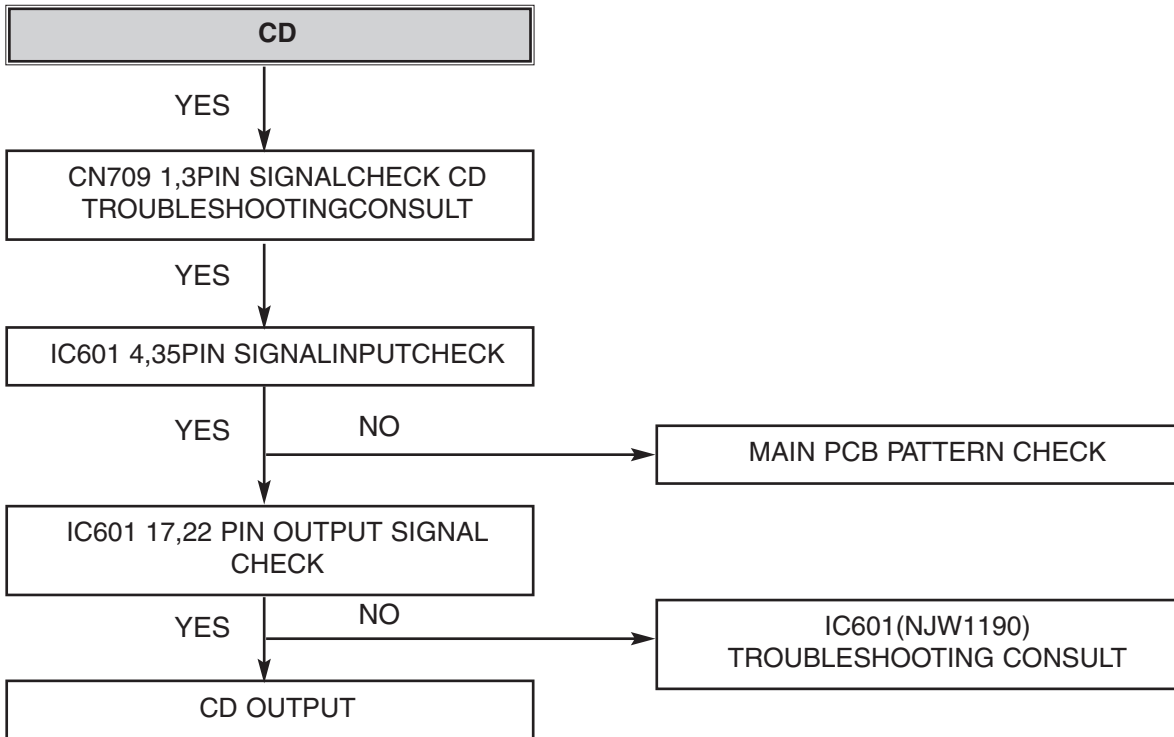
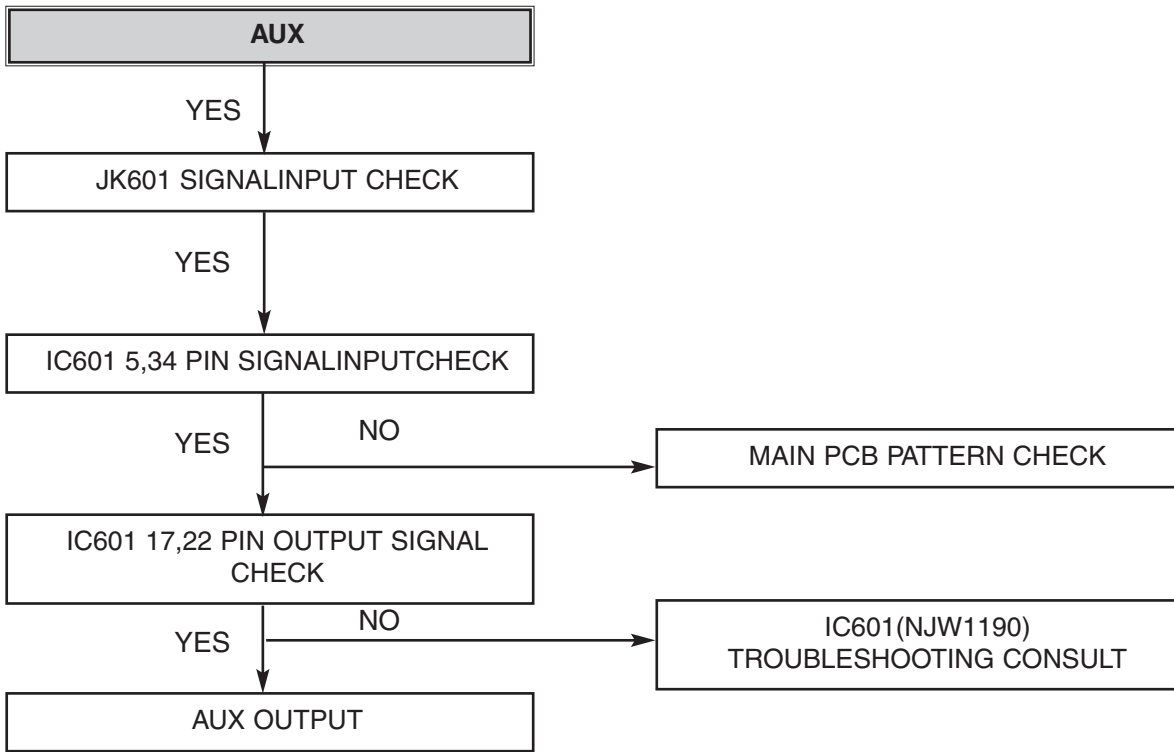

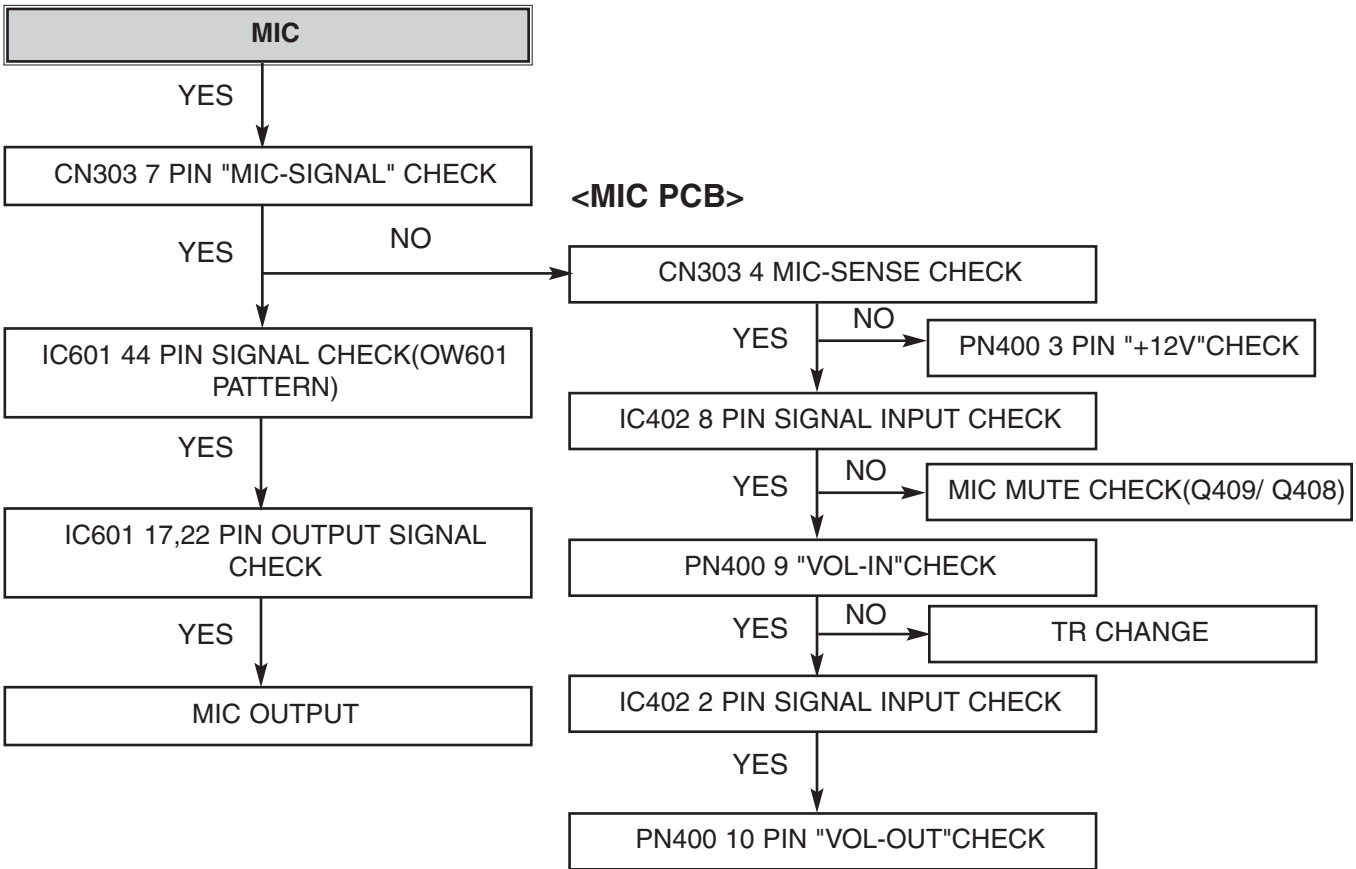
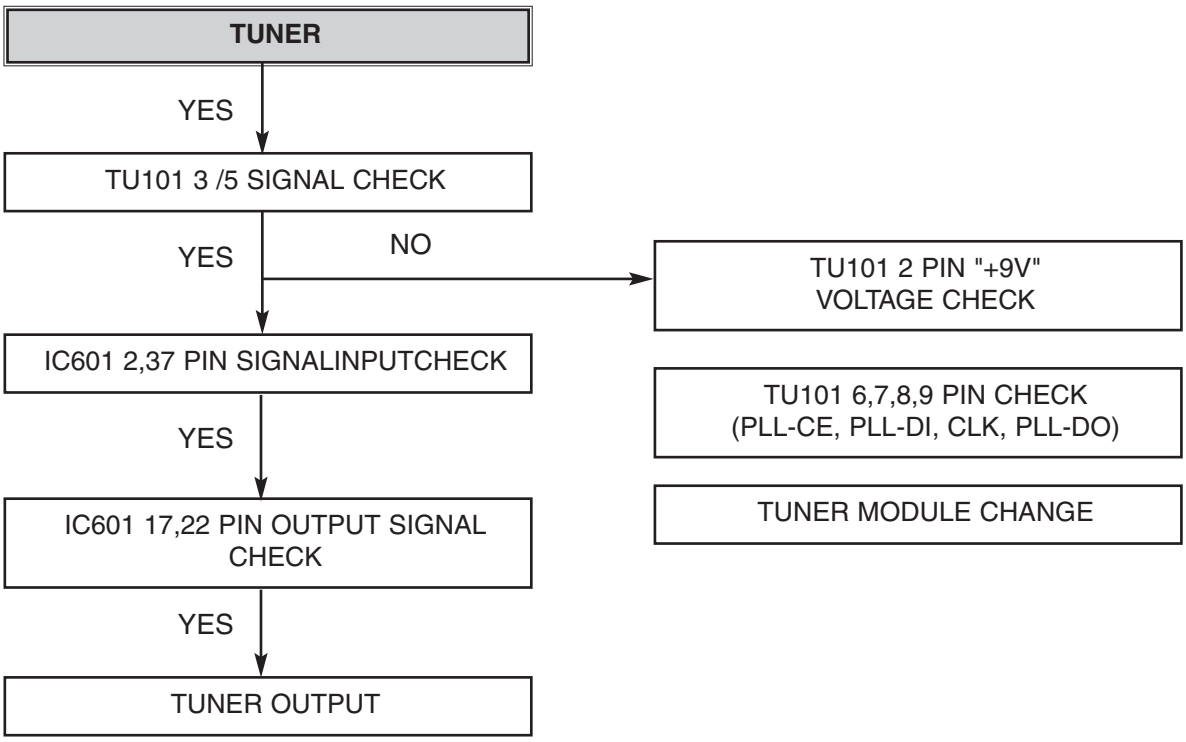

IC601(NJW1190) TROUBLESHOOTING

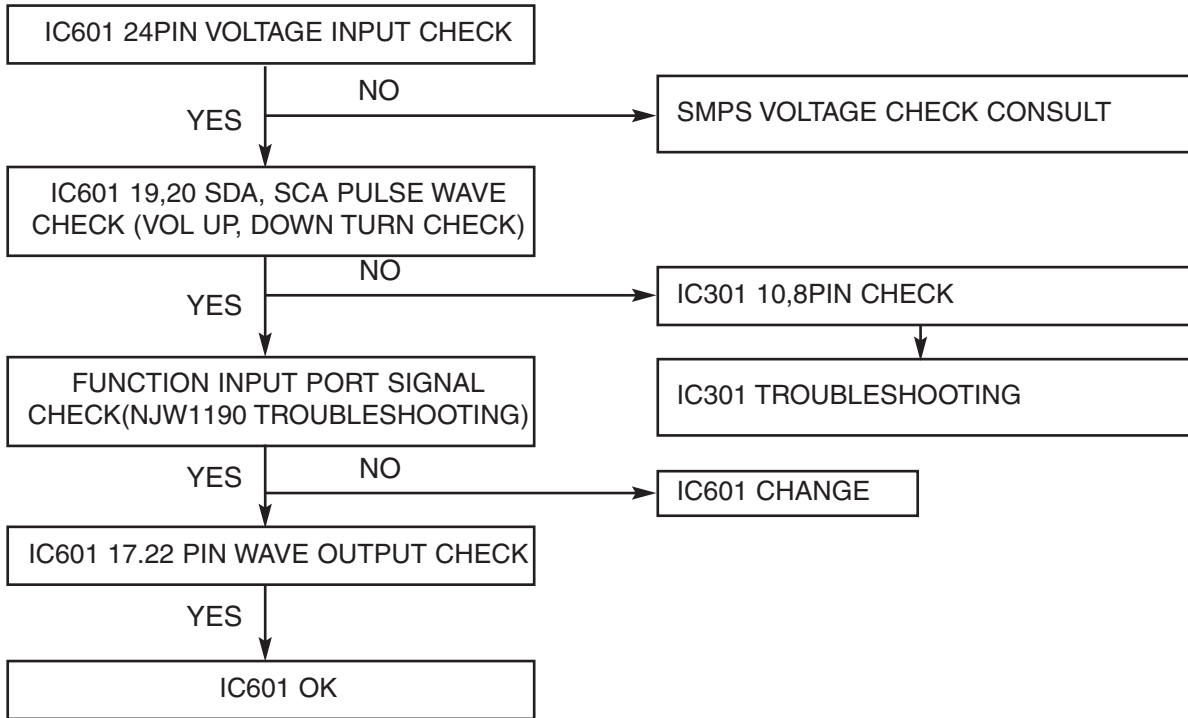

AMP MODULE TROUBLESHOOTING

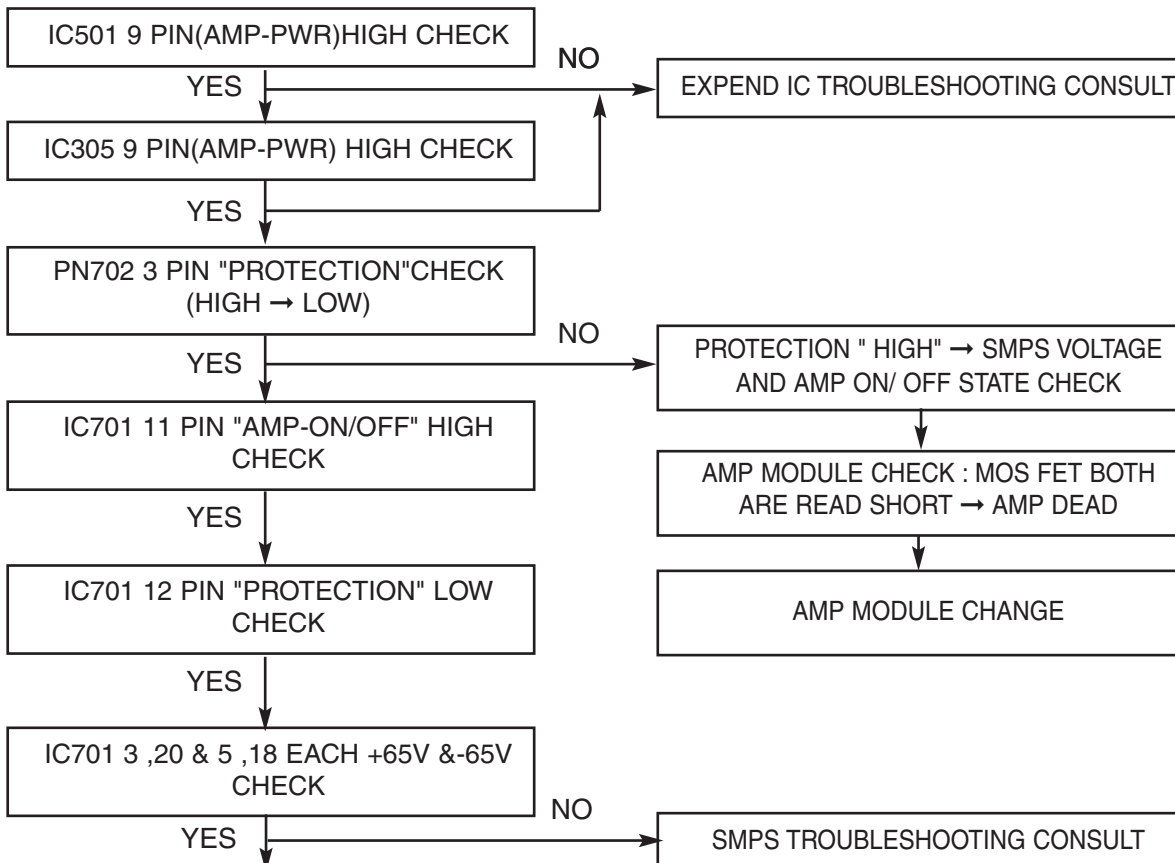

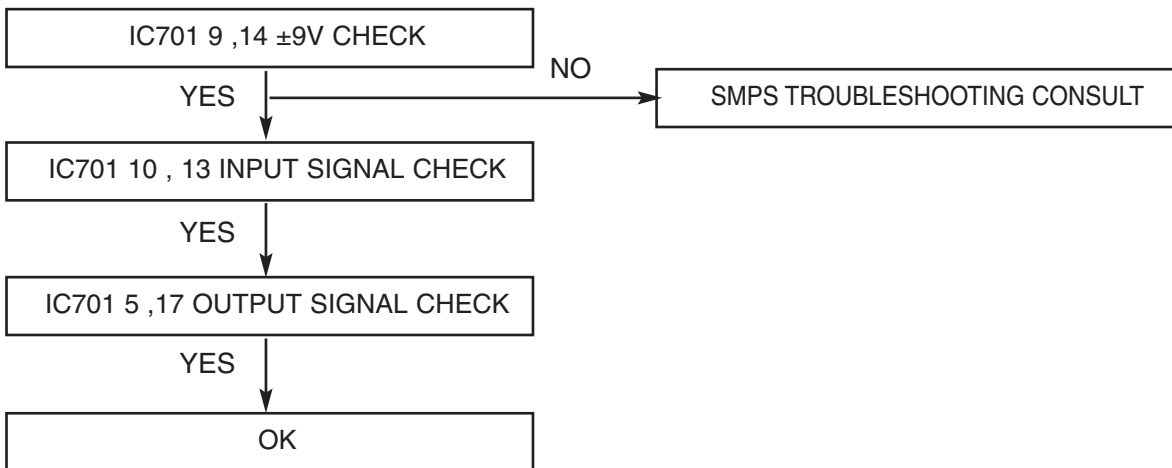

REC CHECK (Q252,Q202 ON :R273,R223 HIGH)

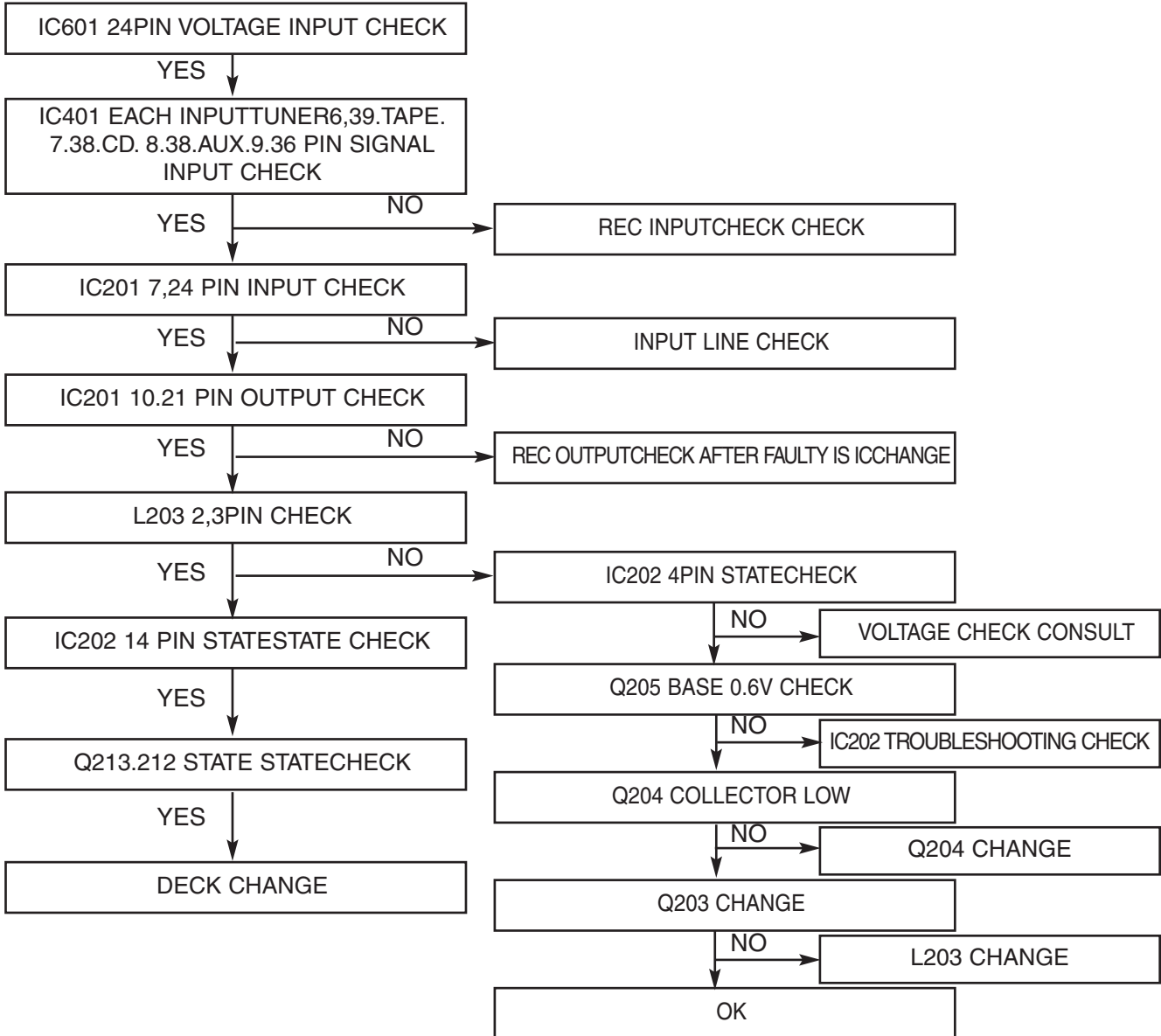

DUBBING CHECK ("NORMAL OR REC"// "HIGH")

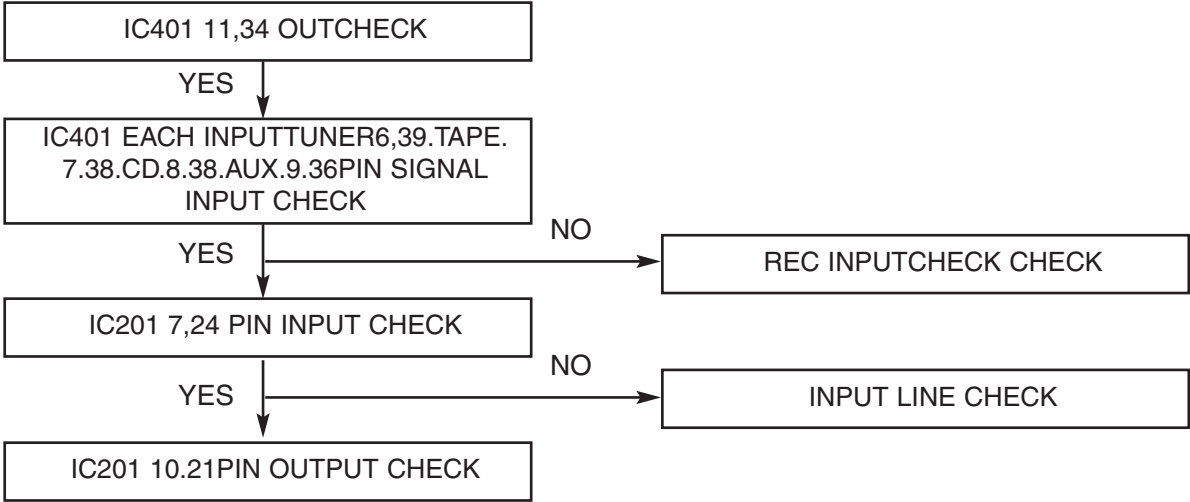

INTERNAL BLOCK DIAGRAM of ICs

• HA12237F BLOCK DIAGRAM

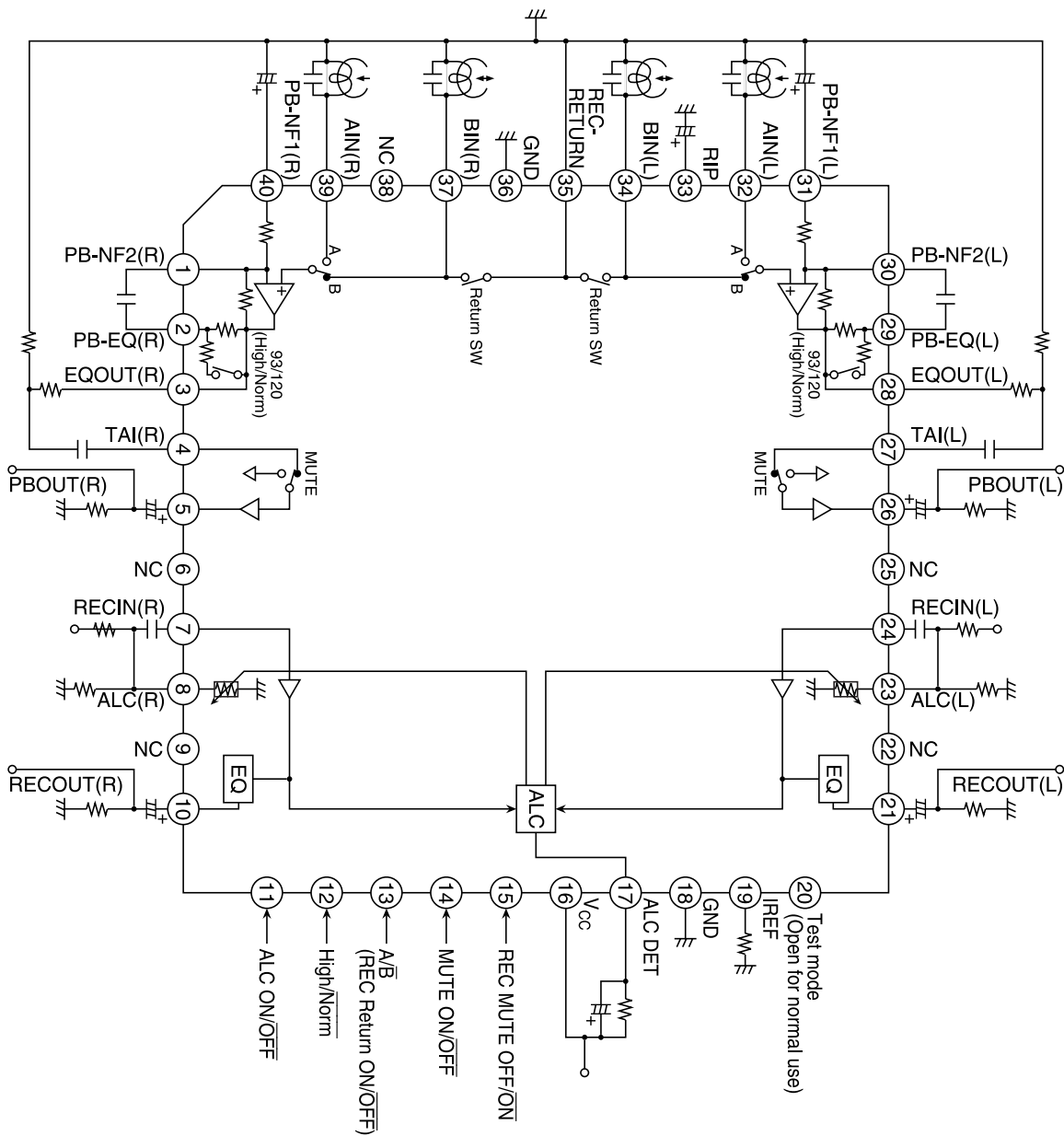

• NJW1190
BLOCK DIAGRAM

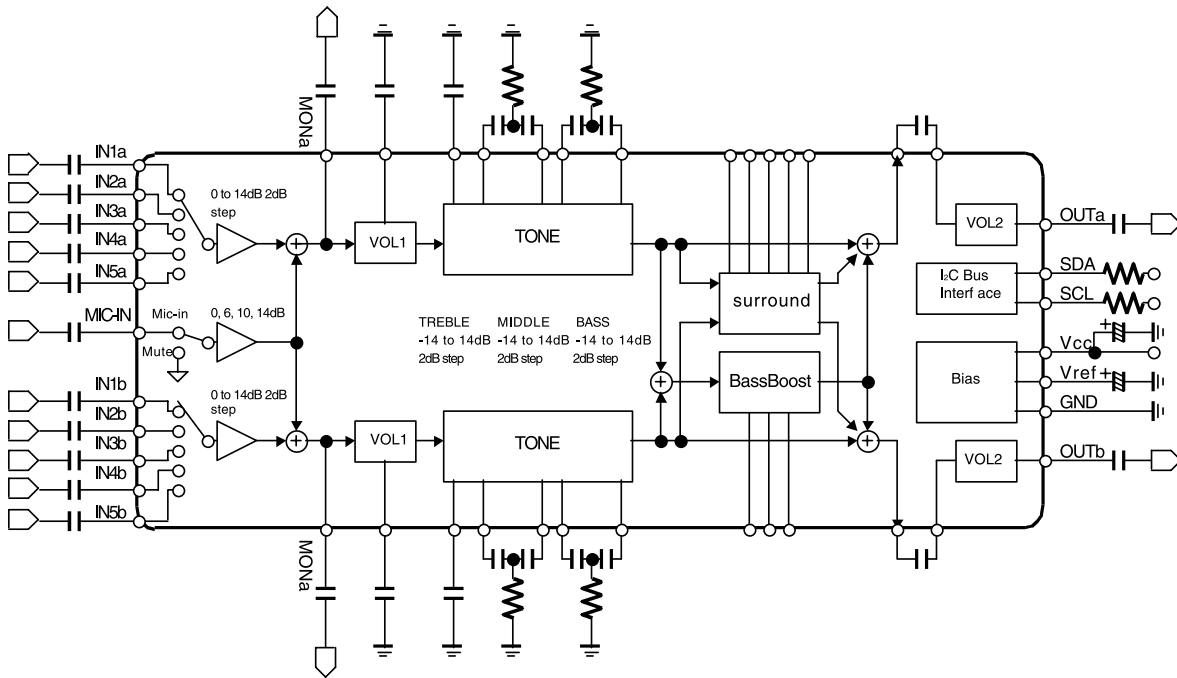

• AF330W20FS
BLOCK DIAGRAM

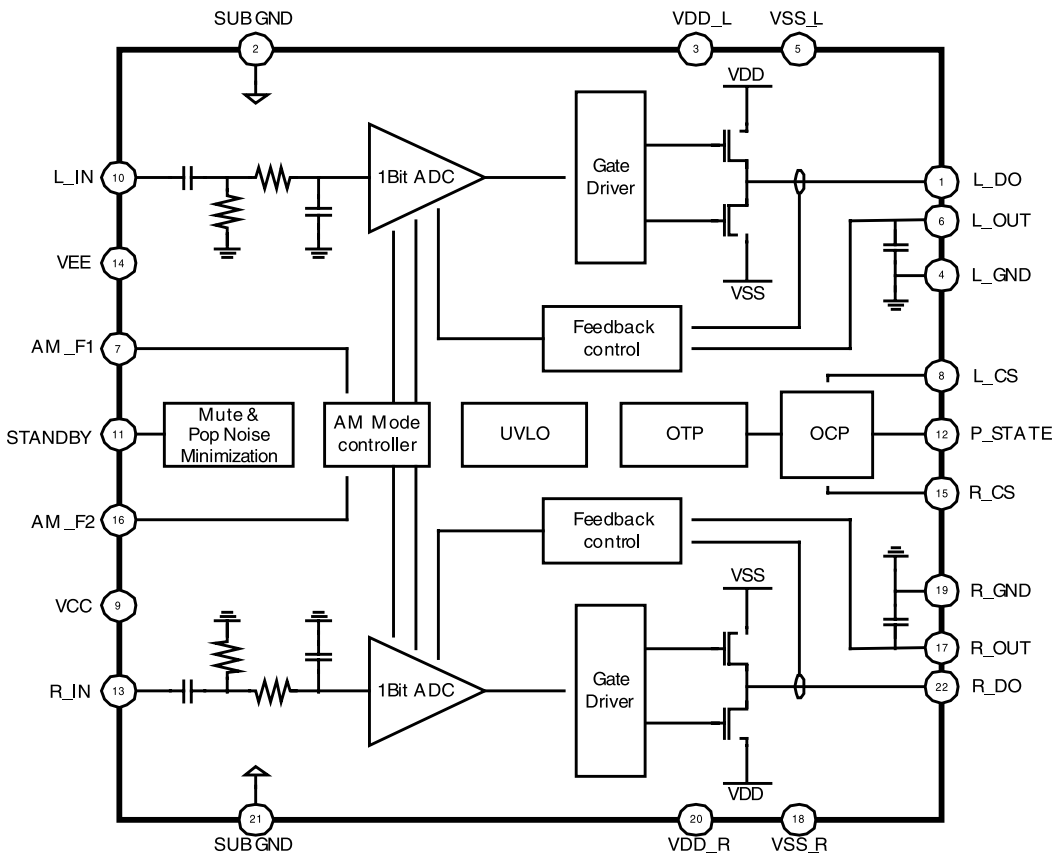

PIN CONFIGURATION

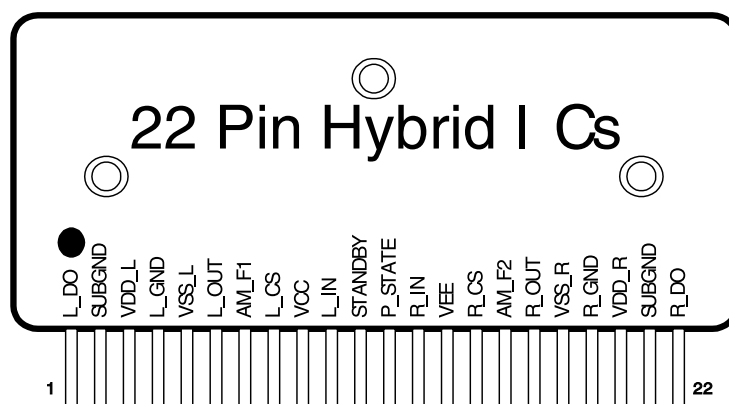

PIN DESCRIPTION

Pin Number	Symbol	Type	Description
1	L_DO	O	L-Channel Drain Output
2	SUBGND	G	Sub Ground
3	VDD_L	P	L-Channel Positive supply Voltage
4	L_GND	P	L-Channel Signal Ground
5	VSS_L	O	L-Channel Negative supply Voltage
6	L_OUT	G	L-Channel Audio Output
7	AM_F1	I	AM Mode control Input 1
8	L_CS	I	L-Channel Current Sense Input
9	VCC	P	Positive supply Voltage
10	L_IN	I	L-Channel Audio Input
11	STANDBY	I	ON/OFF control
12	P_STATE	O	Protection State
13	R_IN	I	R-Channel Audio Input
14	VEE	P	Negative supply Voltage
15	R_CS	I	R-Channel Current Sense Input
16	AM_F2	I	AM Mode control Input 2
17	R_OUT	G	R-Channel Audio Output
18	VSS_R	O	R-Channel Negative supply Voltage
19	R_GND	P	R-Channel Signal Ground
20	VDD_R	P	R-Channel Positive supply Voltage
21	SUBGND	G	Sub Ground
22	R_DO	O	R-Channel Drain Output

• **AF350W01FS**
BLOCK DIAGRAM

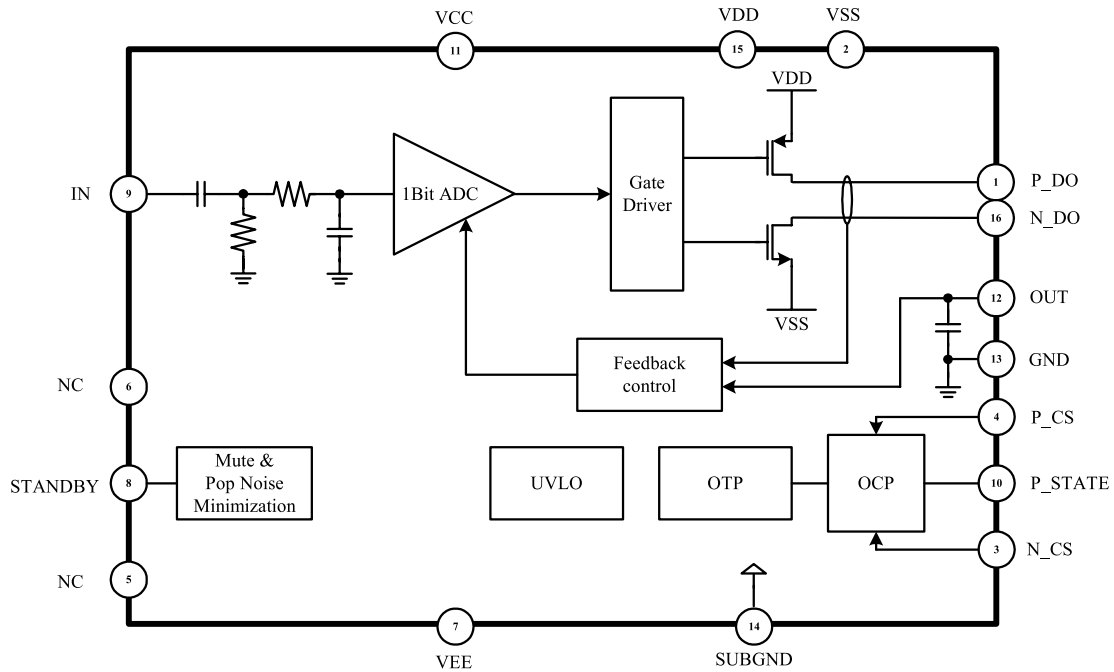

PIN CONFIGURATION

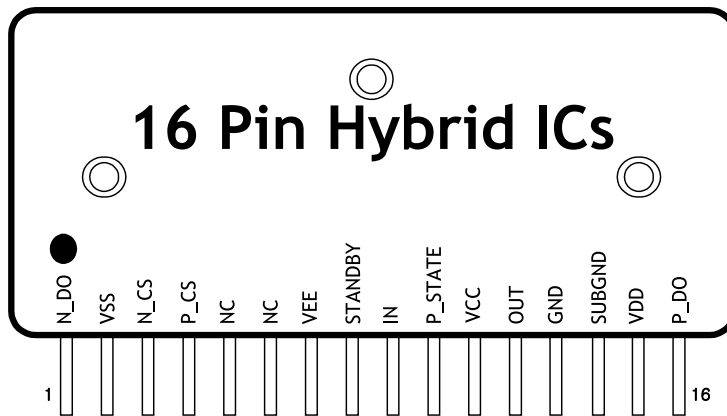

PIN DESCRIPTION

Pin Number	Symbol	Type	Description
1	N_DO	O	NMOS Drain Output
2	VSS	P	Negative supply Voltage
3	N_CS	I	NMOS Current Sense Input
4	P_CS	I	PMOS Current Sense Input
5	NC		
6	NC		
7	VEE	P	Negative supply Voltage
8	STANDBY	I	ON/OFF control
9	IN	I	Audio Input
10	P_STATE	O	Protection State
11	VCC	P	Positive supply Voltage
12	OUT	O	Audio Output
13	GND	G	Signal Ground
14	SUBGND	G	Sub Ground
15	VDD	P	Positive supply Voltage
16	P_DO	O	PMOS Drain Output

□ BLOCK DIAGRAM

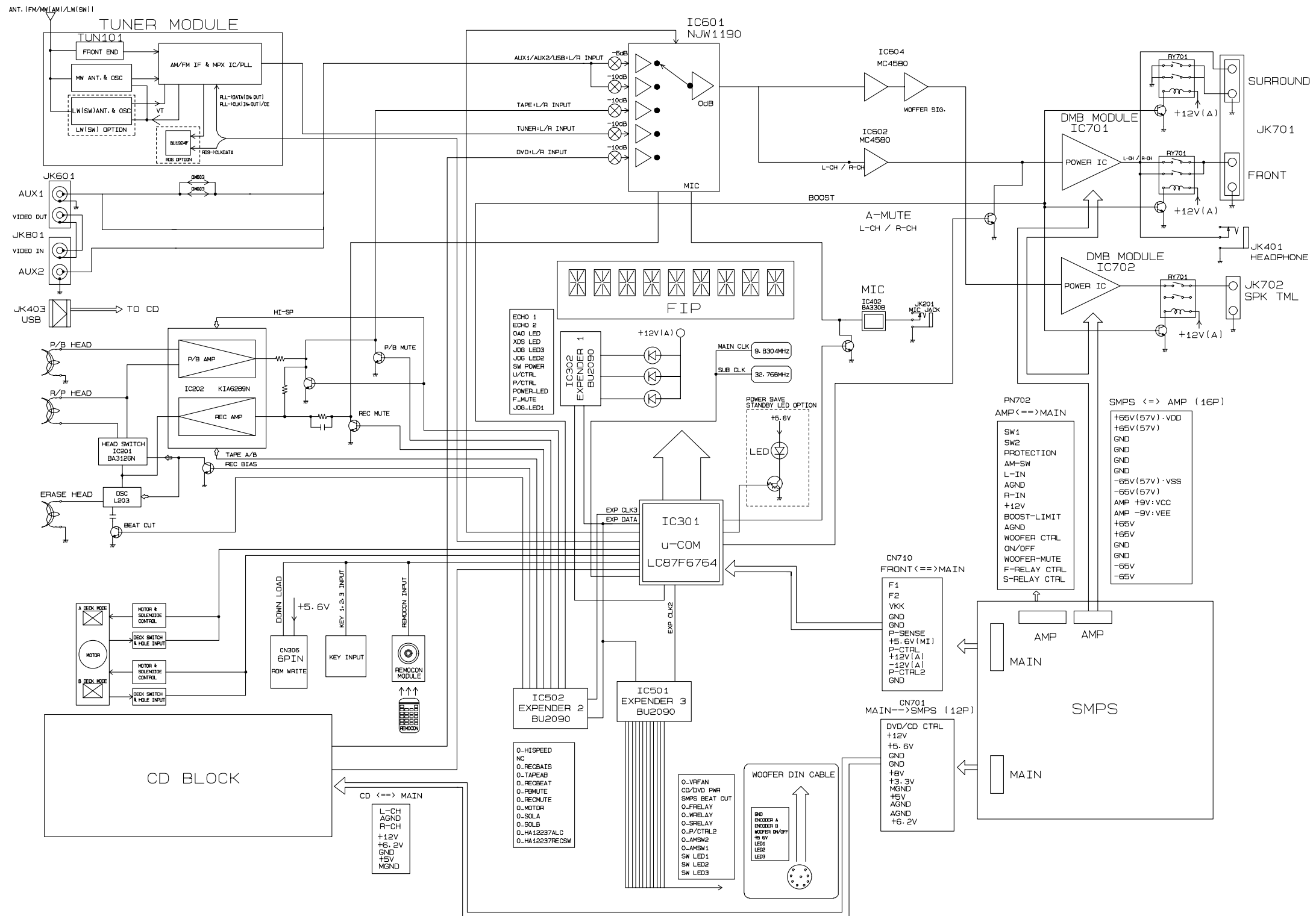

WMA_USB BLOCK DIAGRAM

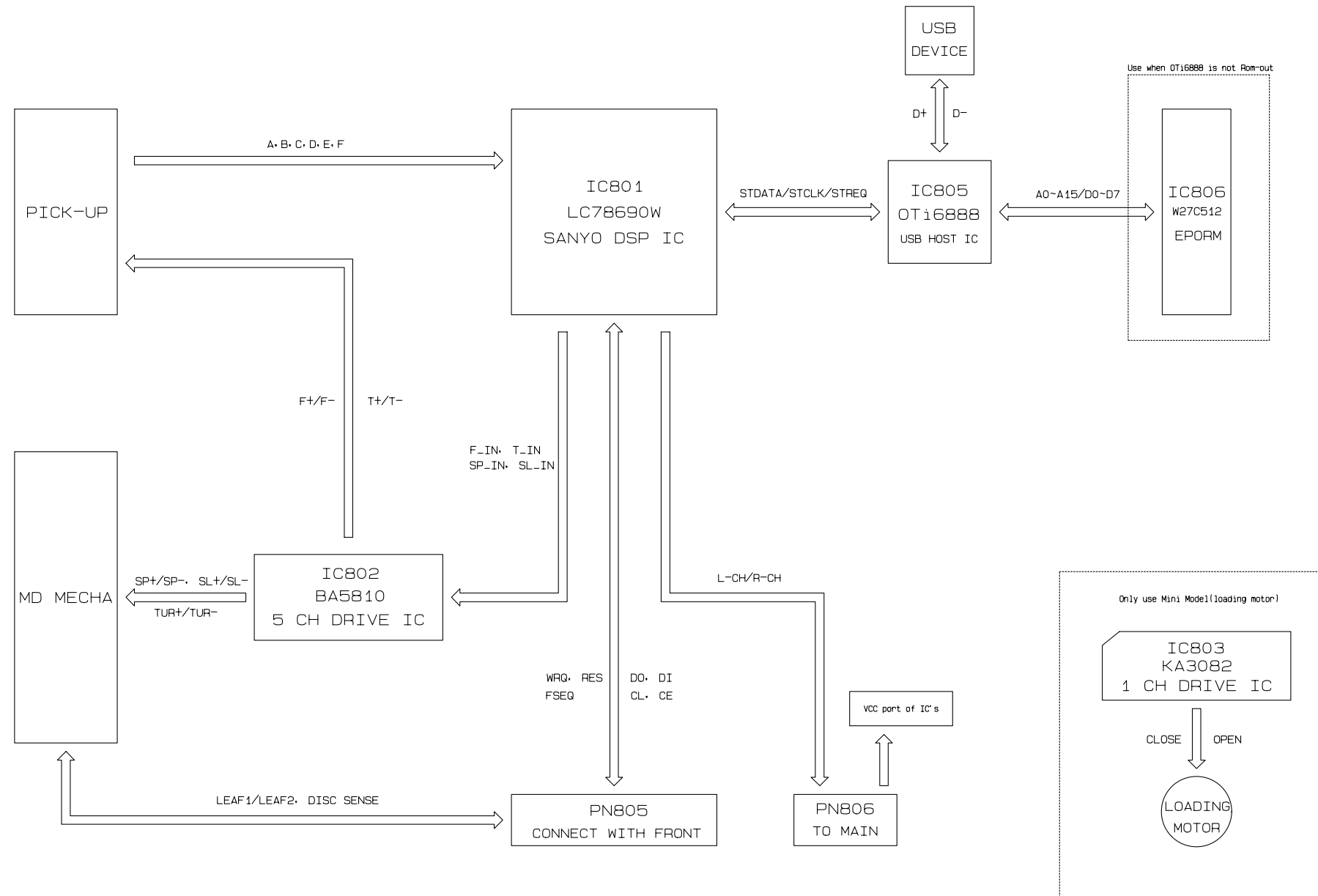

WMA + USB BLOCK DIAGRAM

3854R16855A_003.sht

SCHEMATIC DIAGRAMS

FRONT SCHEMATIC DIAGRAM

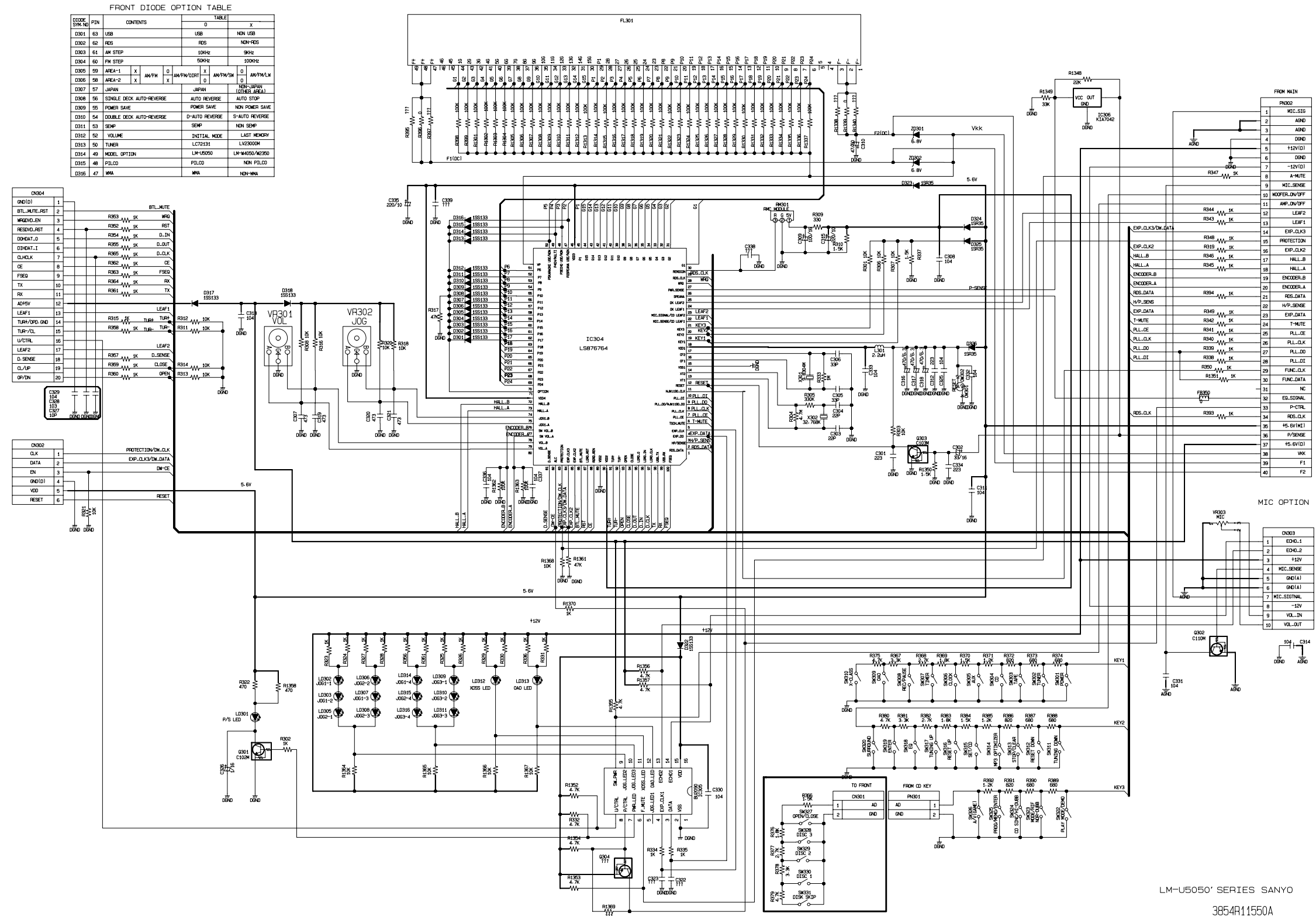

• MAIN SCHEMATIC DIAGRAM

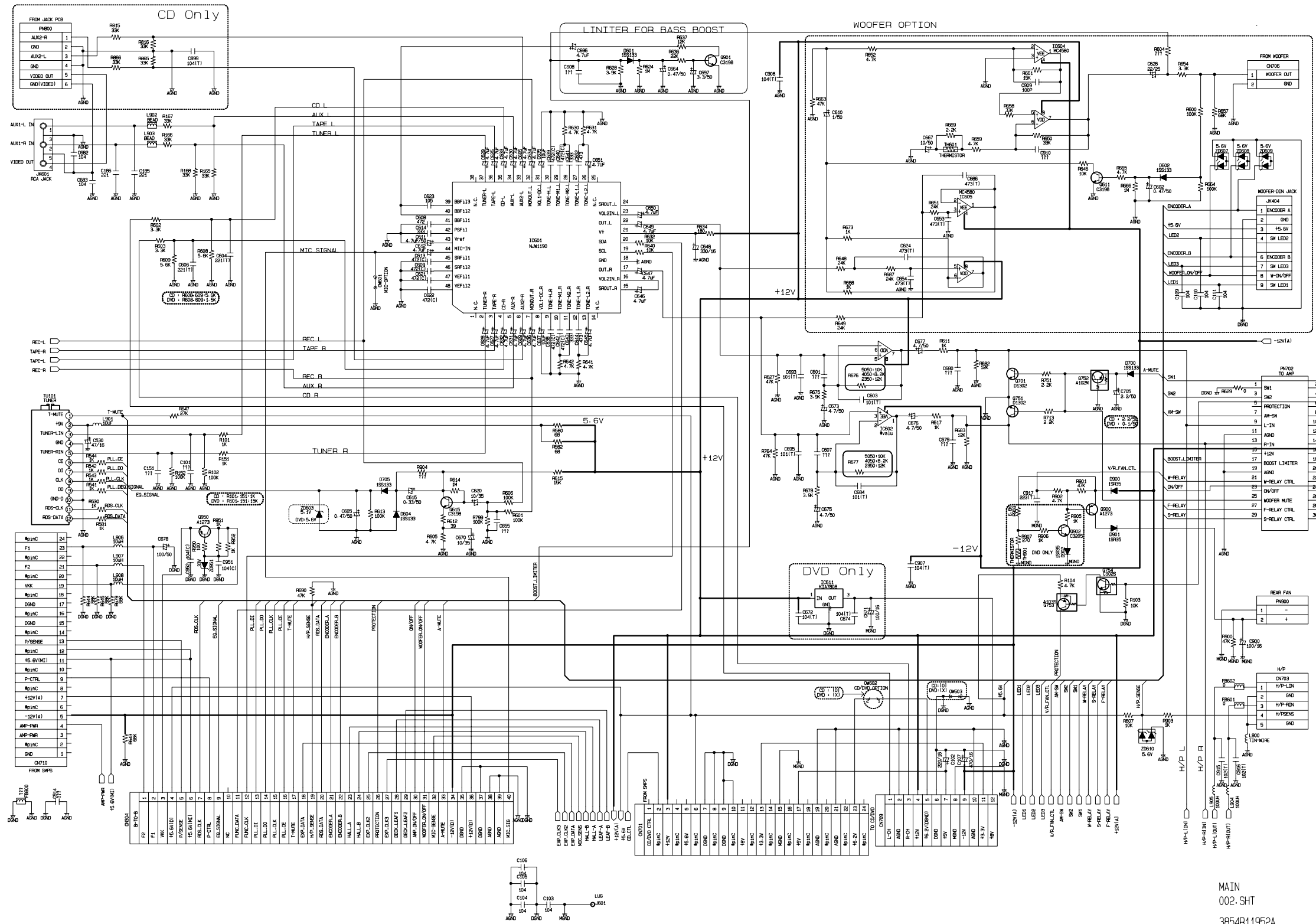

• DECK SCHEMATIC DIAGRAM

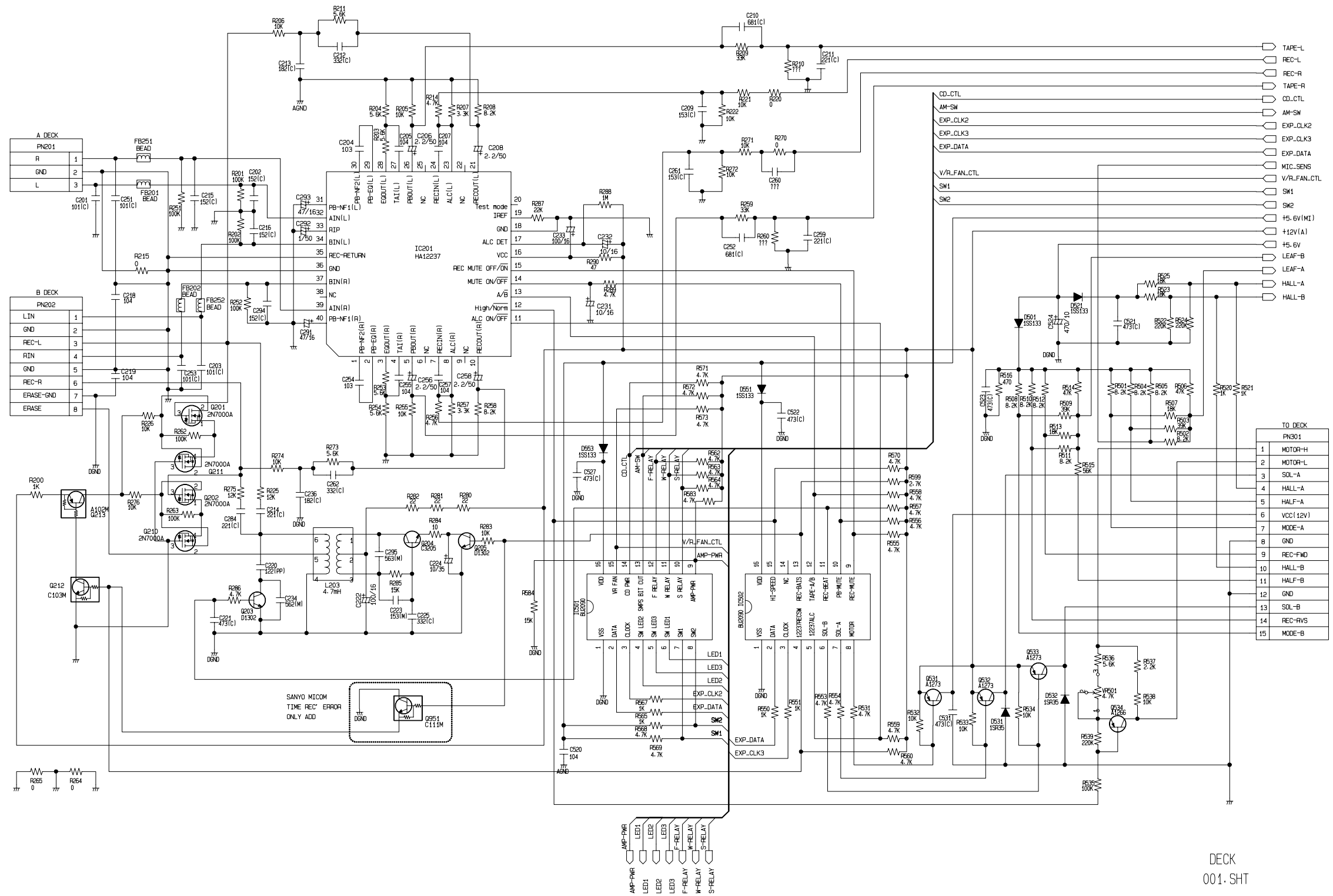

DECK
001.SHT
3854R1 1952A

• MIC SCHEMATIC DIAGRAM

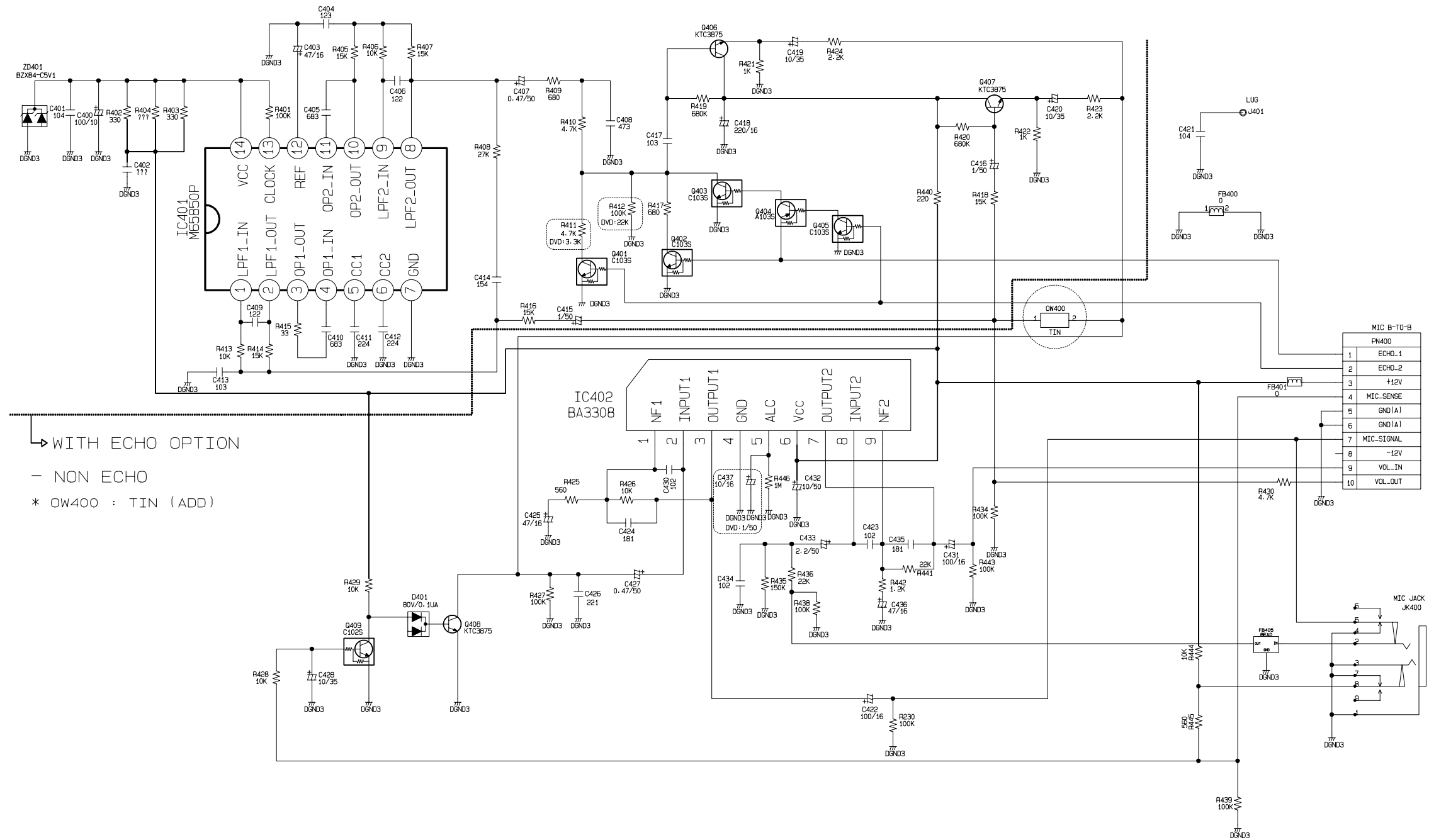

MIC B-T-O-B	
Pin	Label
1	ECHO_1
2	ECHO_2
3	+12V
4	MIC-SENSE
5	GND (A1)
6	GND (A1)
7	MIC-SIGNAL
8	-12V
9	VOL-IN
10	VOL-OUT

MIC
 004.SHT
 3854R11952A

• USB_AUX2_H/P SCHEMATIC DIAGRAM

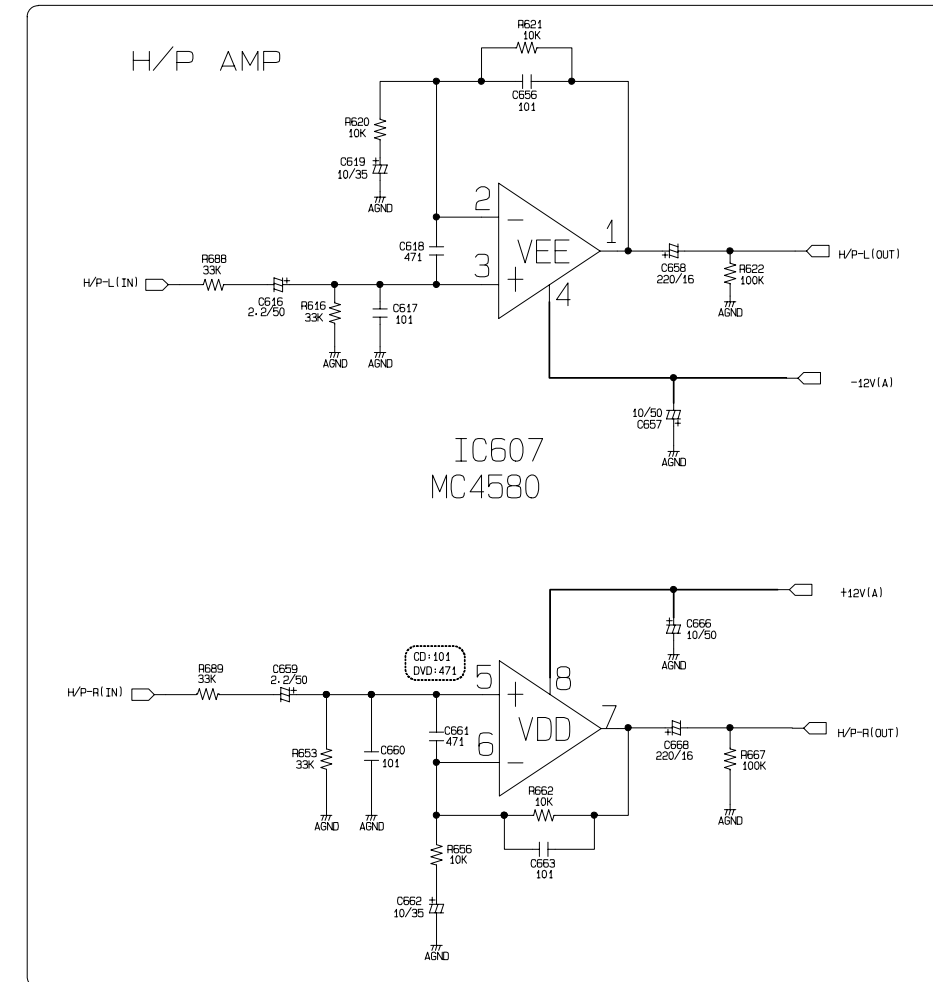
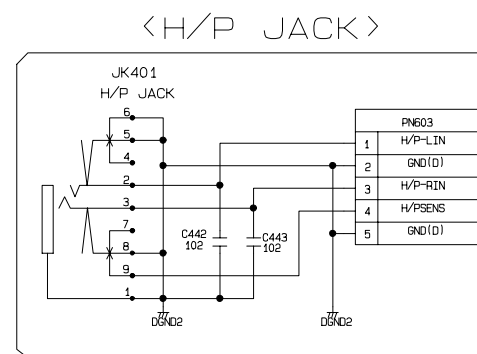
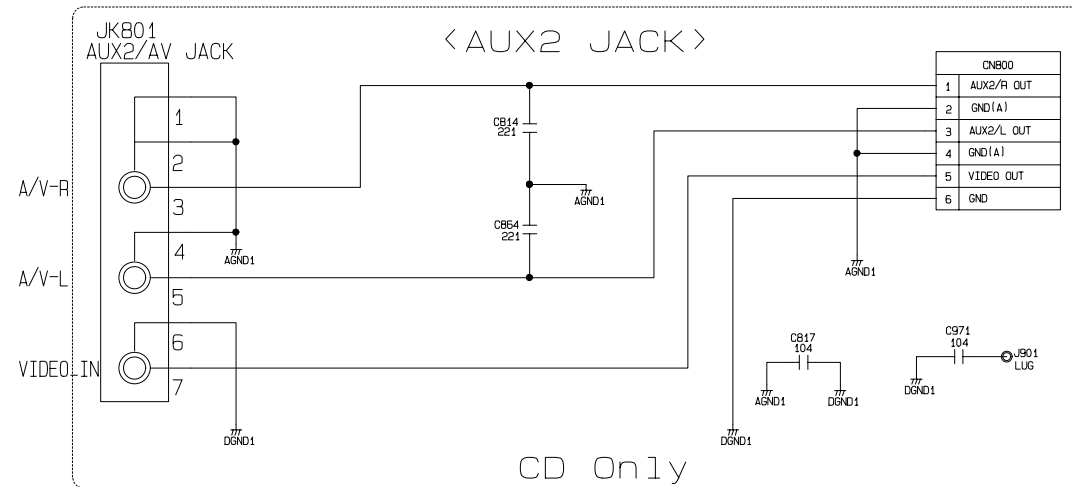
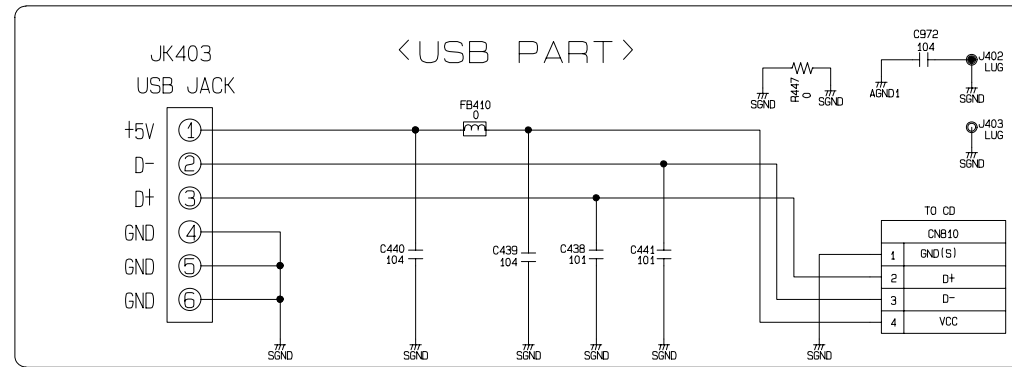

USB+AUX2+H/P
003. SHT
3854R1 1952A

• WOOFER AMP SCHEMATIC DIAGRAM

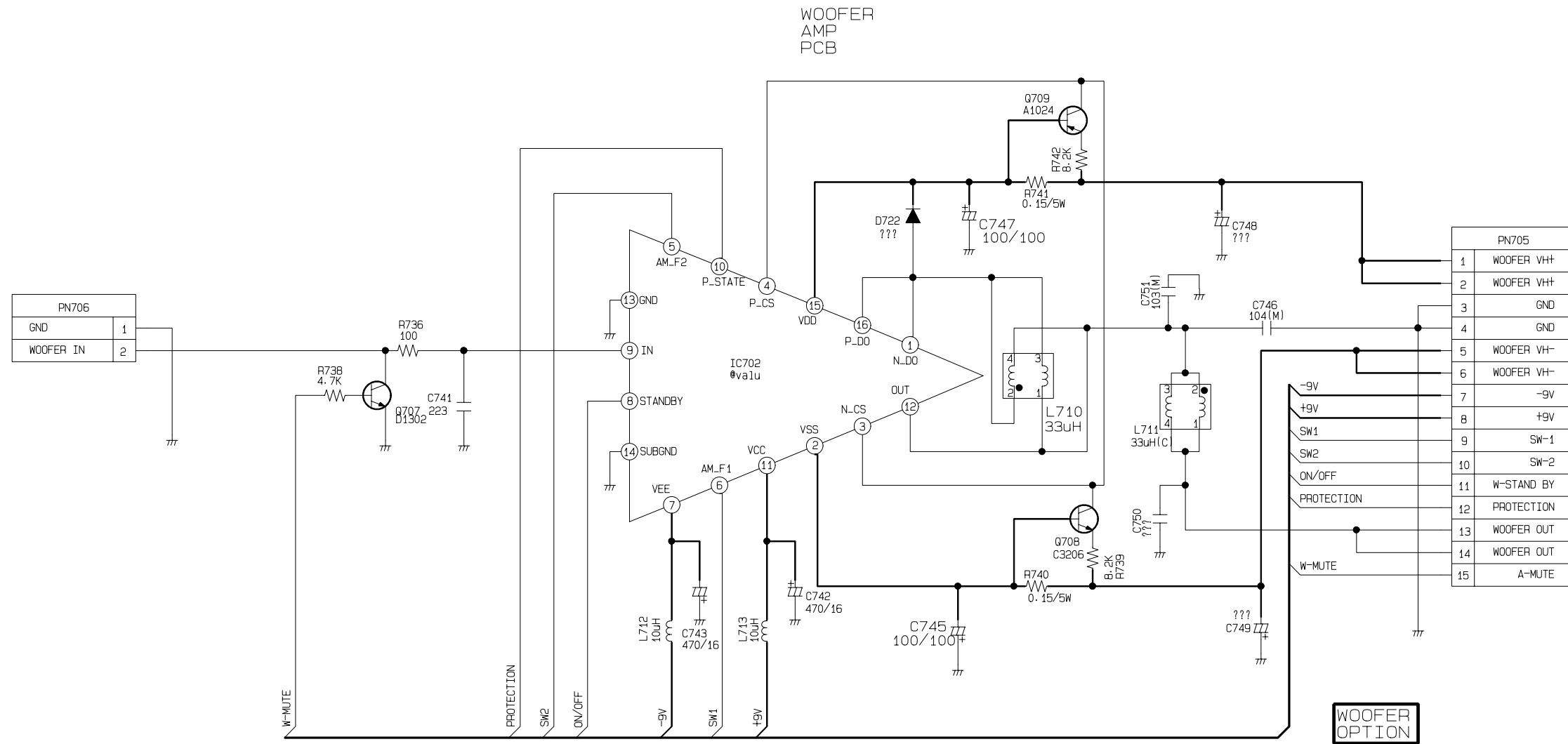

WOOFER AMP

3854R11955A

• AMP SCHEMATIC DIAGRAM

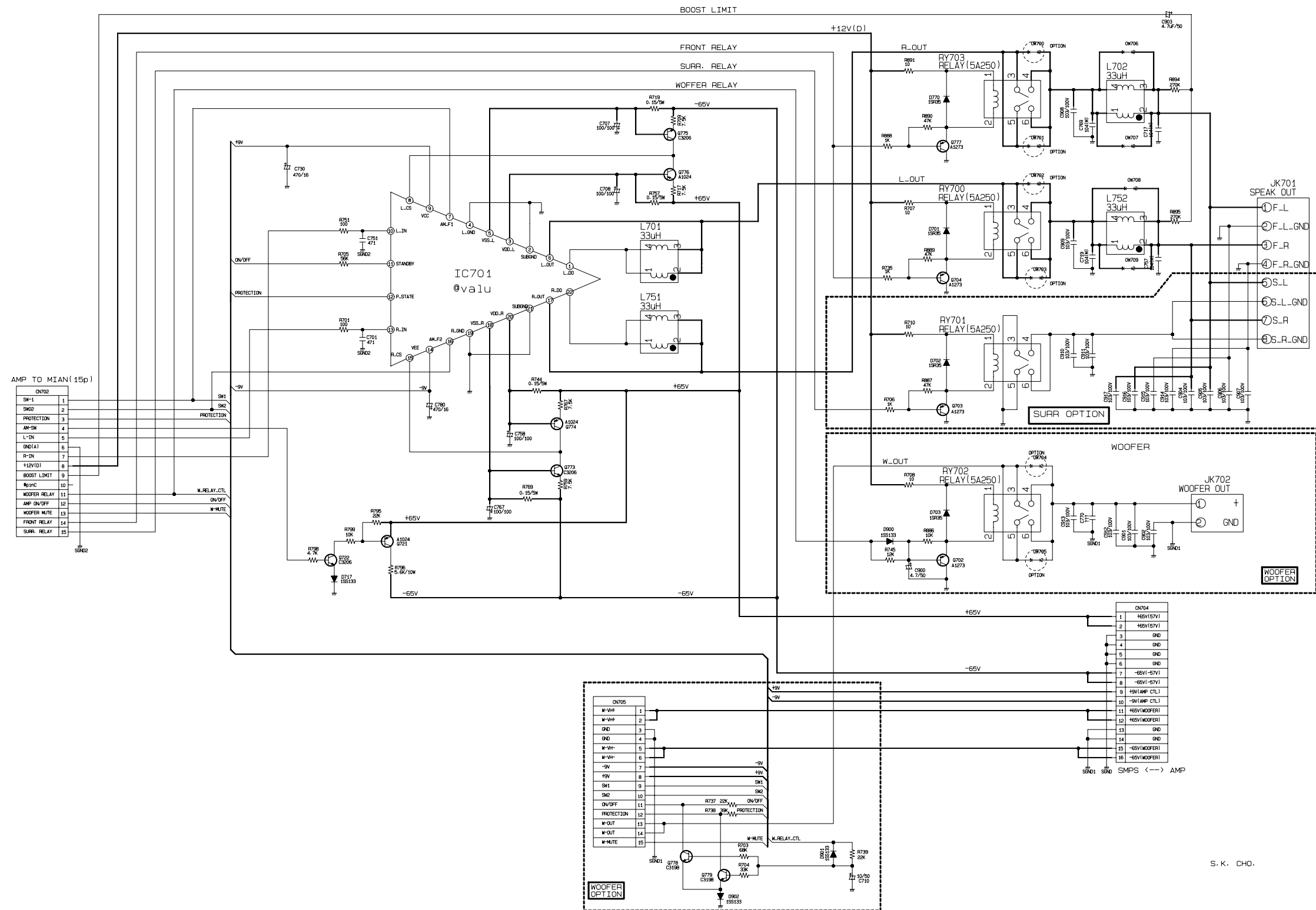

S. K. CHO.

• SUB POWER SCHEMATIC DIAGRAM

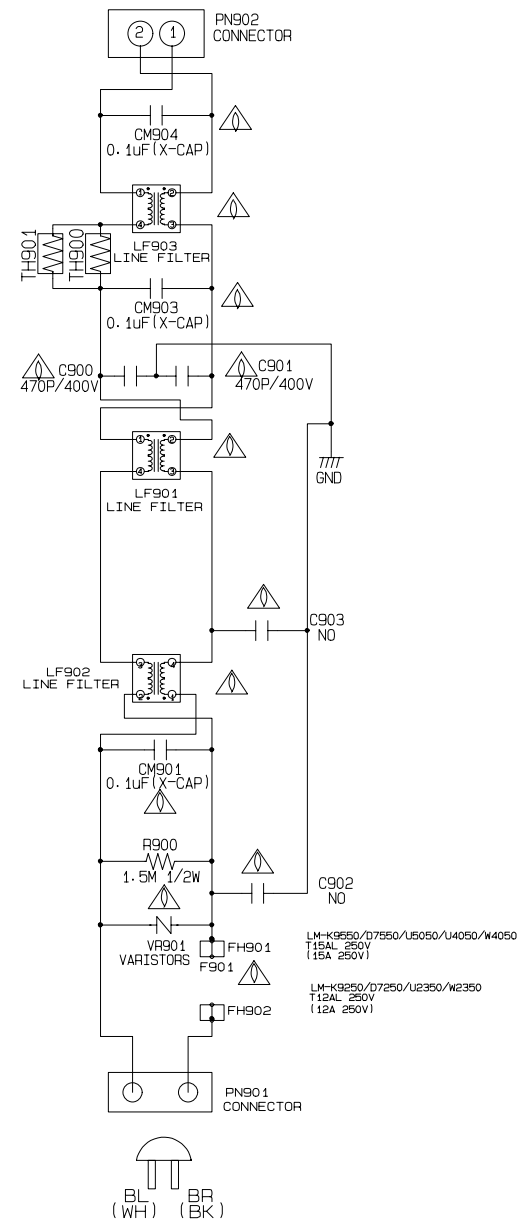

SCHEMATIC(SUB SMPS-WIDE)
 LM-K9550 series
 3854R19546A

• POWER SCHEMATIC DIAGRAM (LM-U5050/U4050/K9550/D7550)

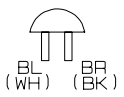
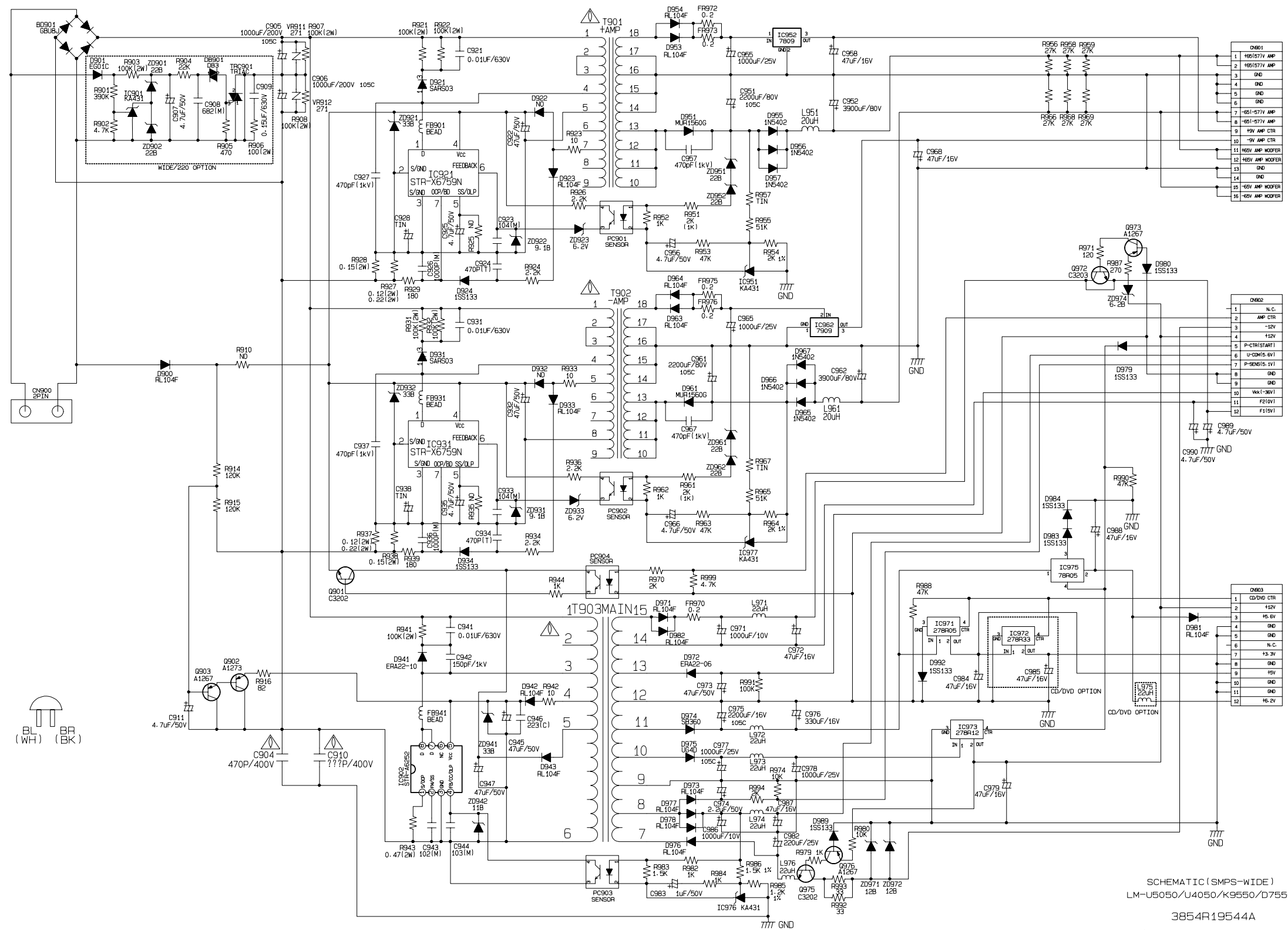

SCHEMATIC (SMPS-WIDE)
LM-U5050/U4050/K9550/D7550
3854R19544A

• POWER SCHEMATIC DIAGRAM (LM-U2350/K9250/D7250 SERIES)

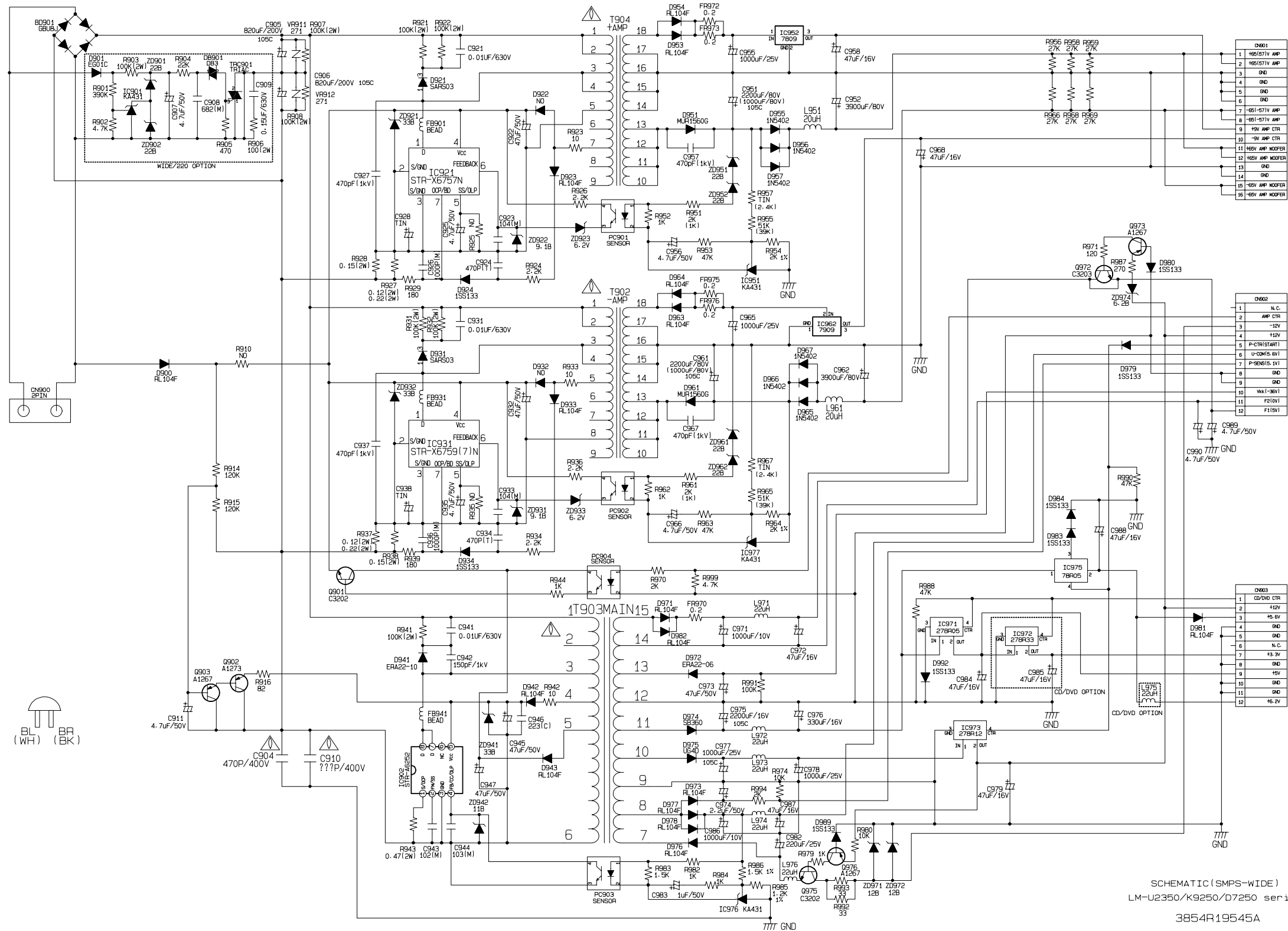

• CDP SCHEMATIC DIAGRAM

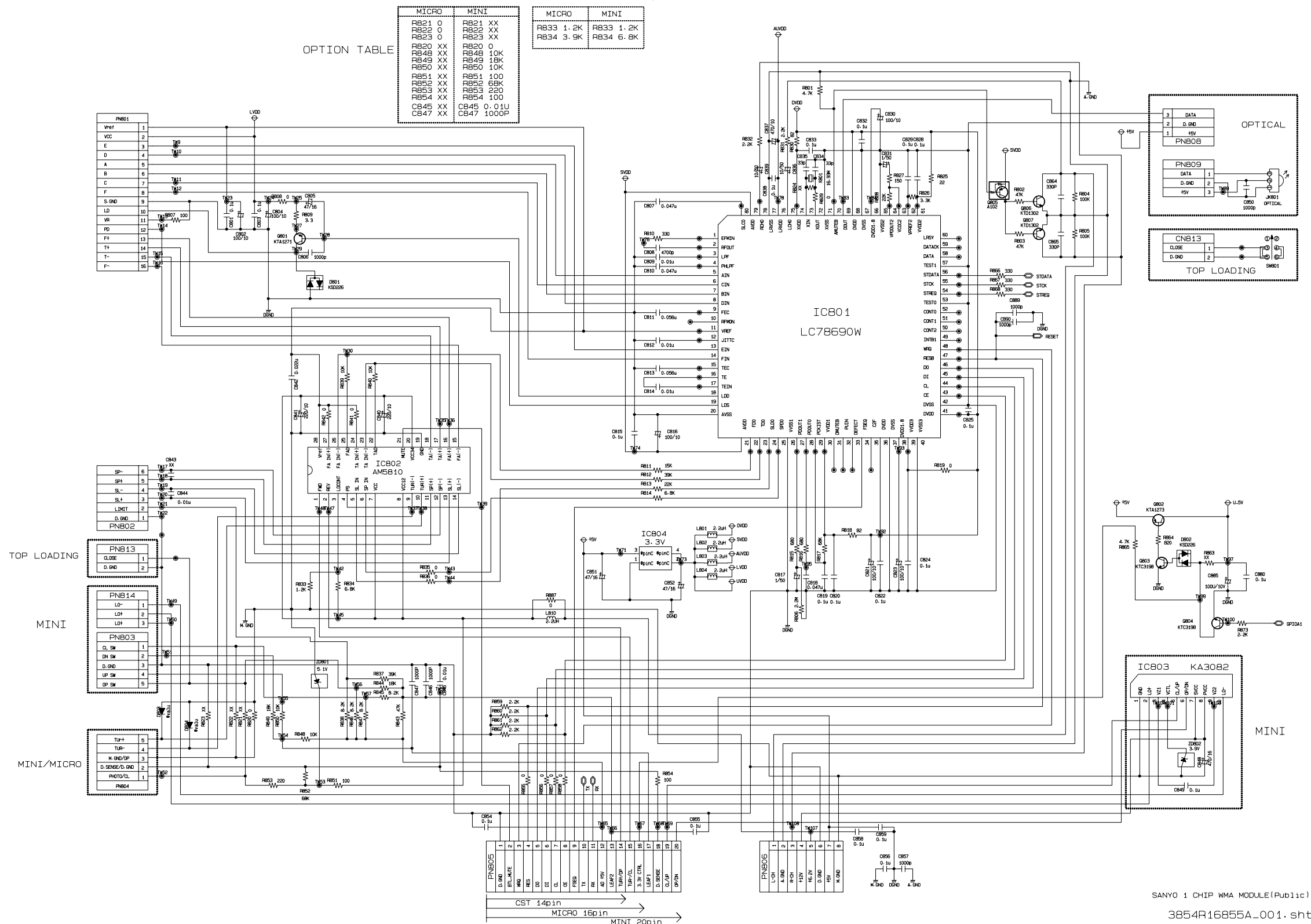

• USB SCHEMATIC DIAGRAM

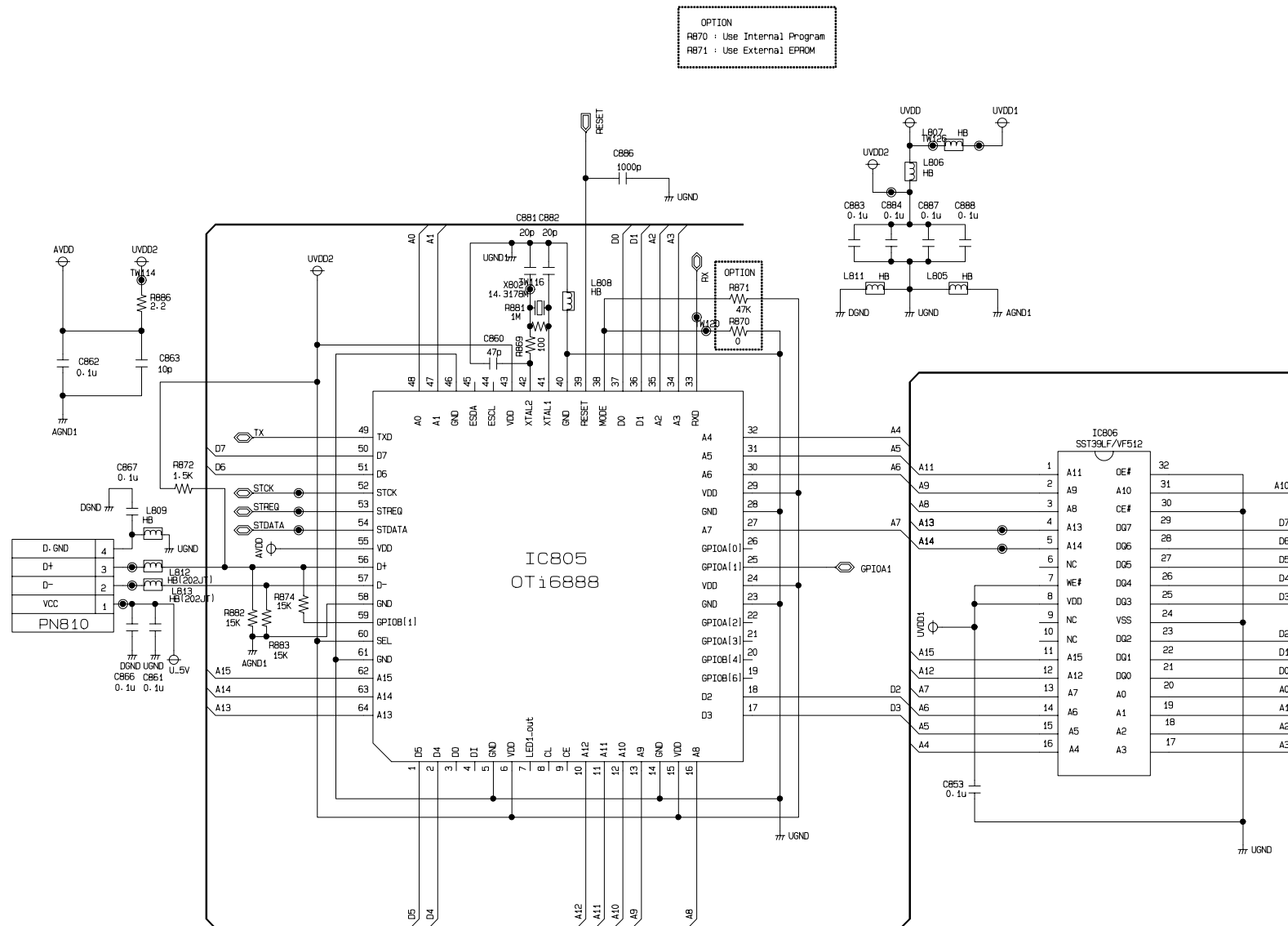

USB Part
 854R16855A_002.sht

WIRING DIAGRAMS

○ HIGH POWER MINI WIRING (LM-U5050/4050/2350)

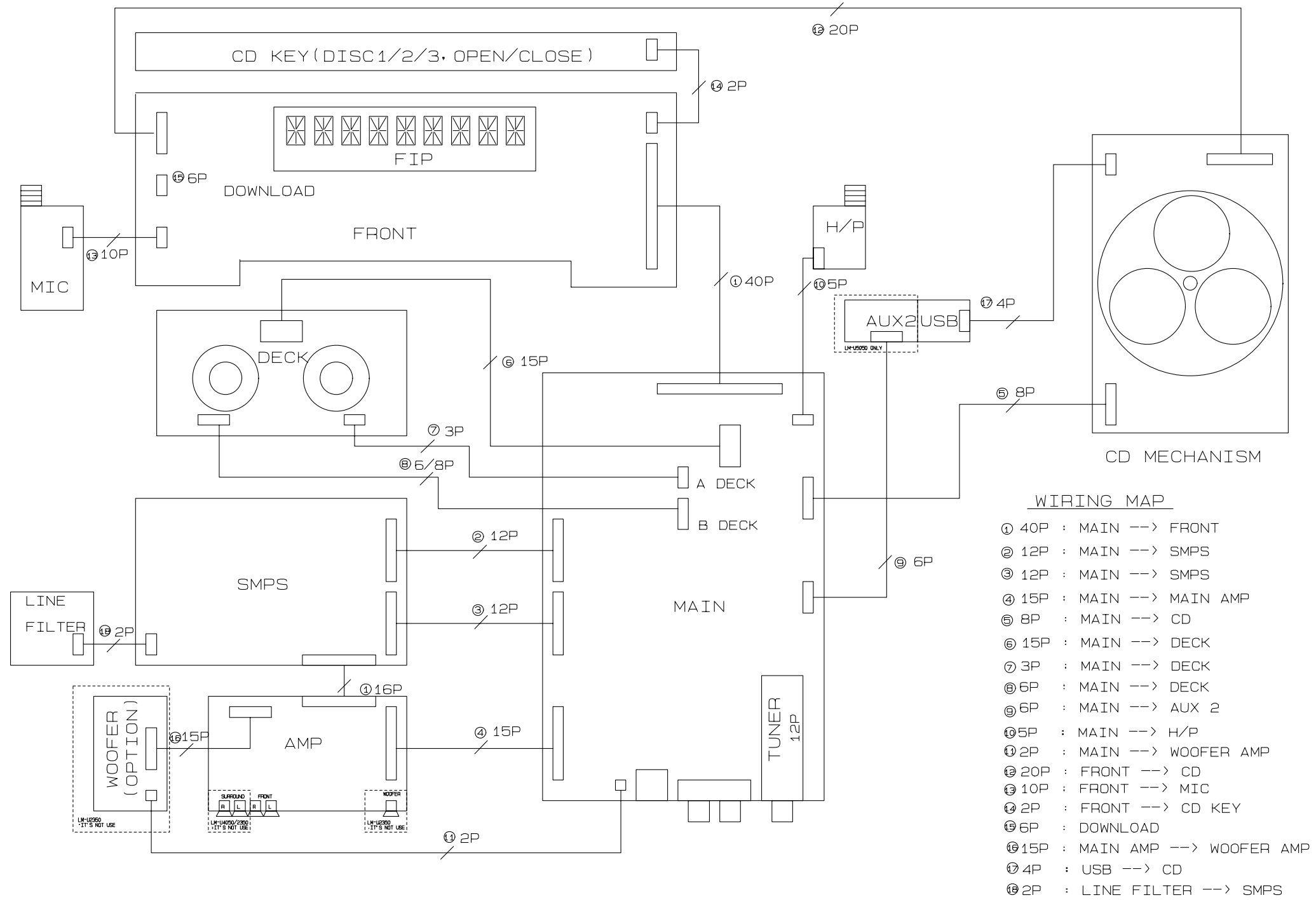

SD0401687

LM-U5050/W4050/W2350

PRINTED CIRCUIT DIAGRAMS

MAIN P.C. BOARD

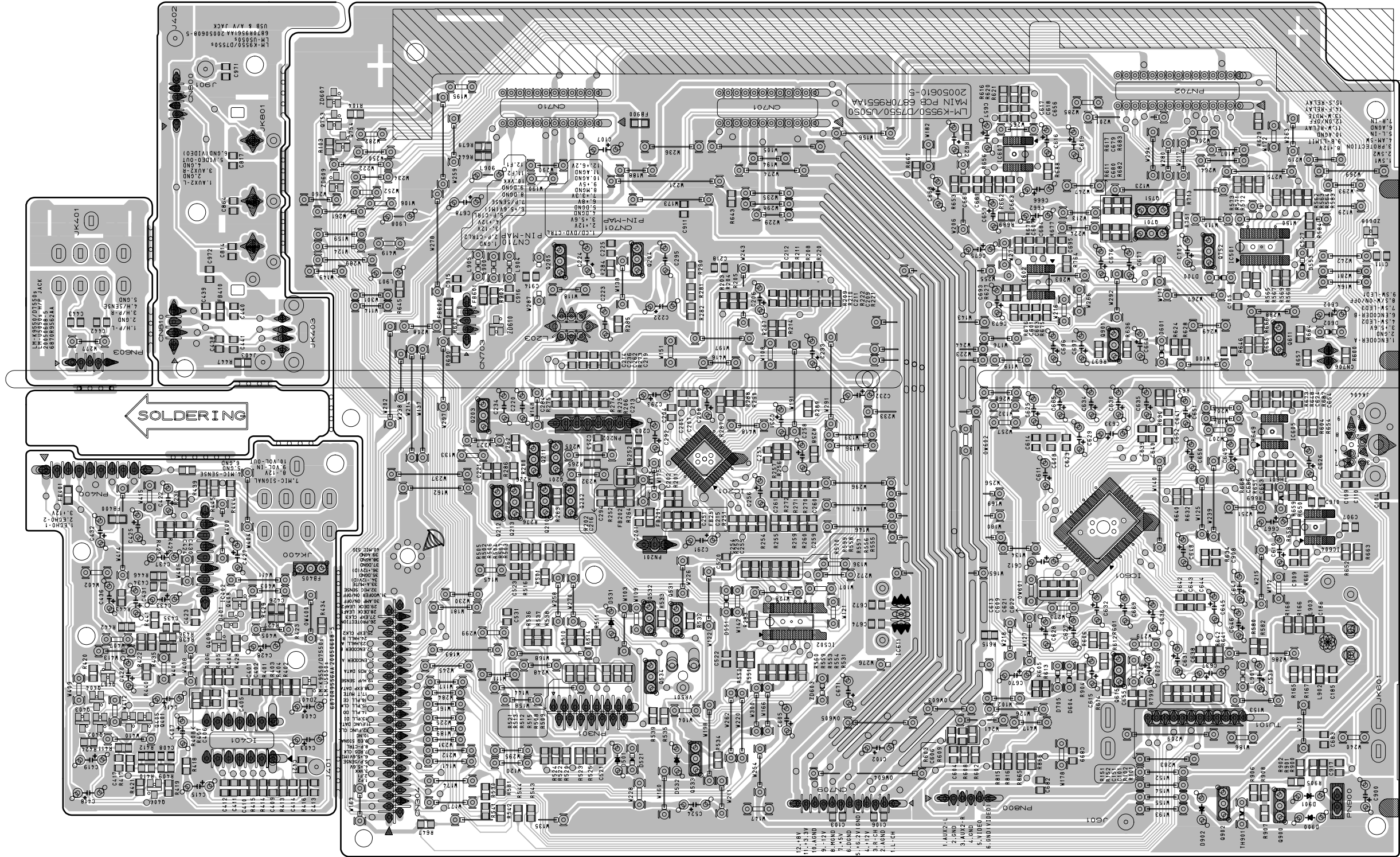

• MAIN AMP P.C. BOARD

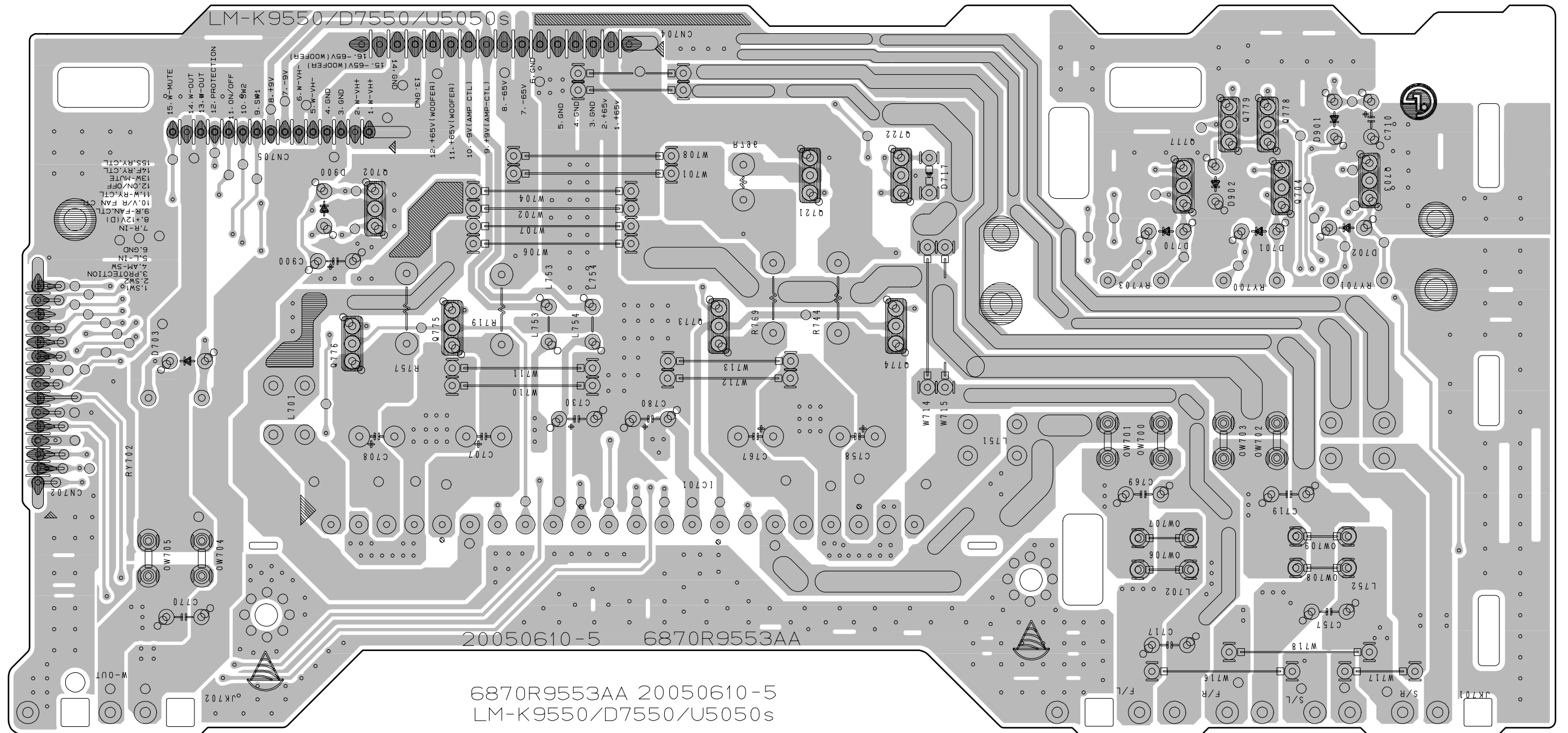

• FRONT P.C. BOARD

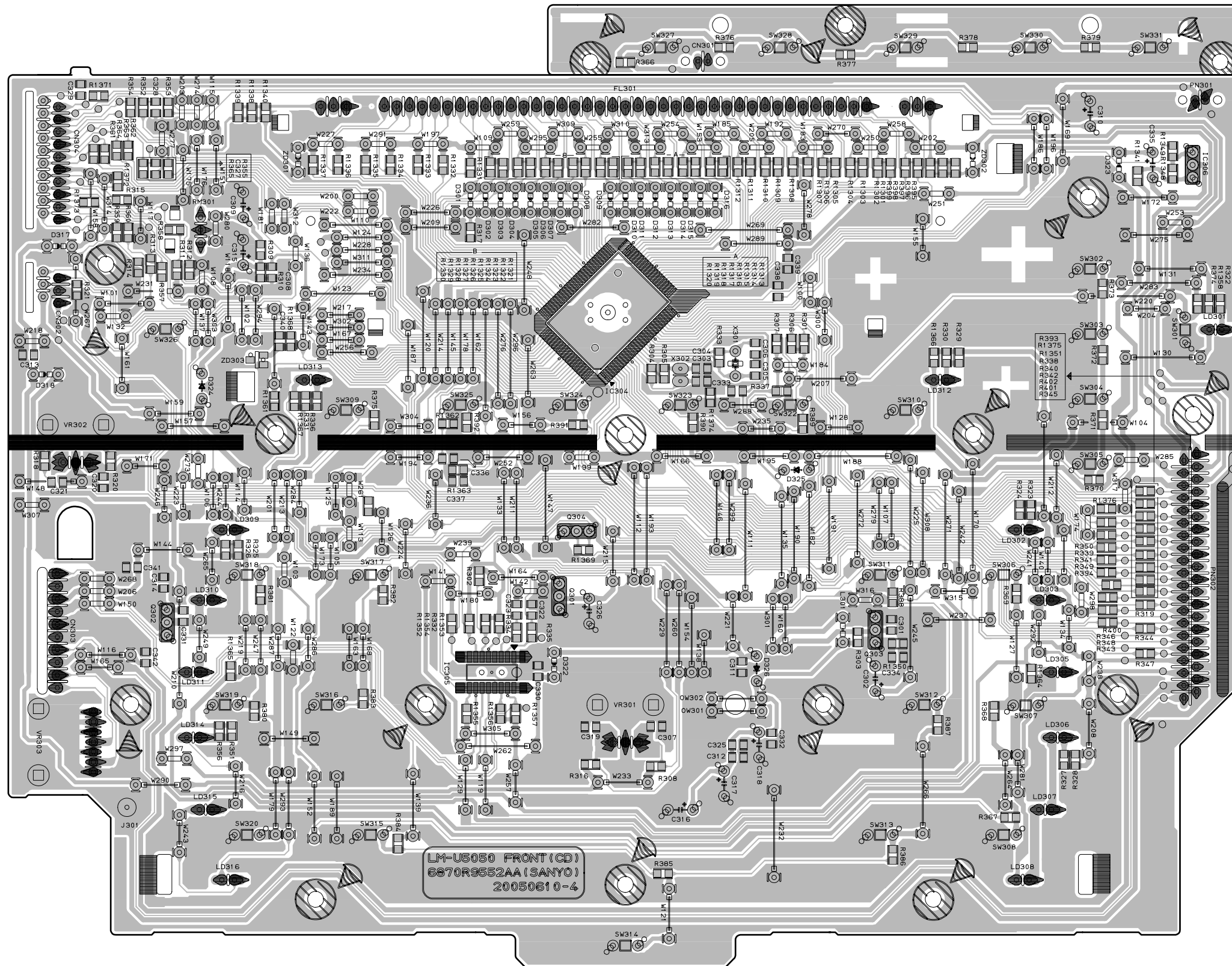

• CDP P.C. BOARD

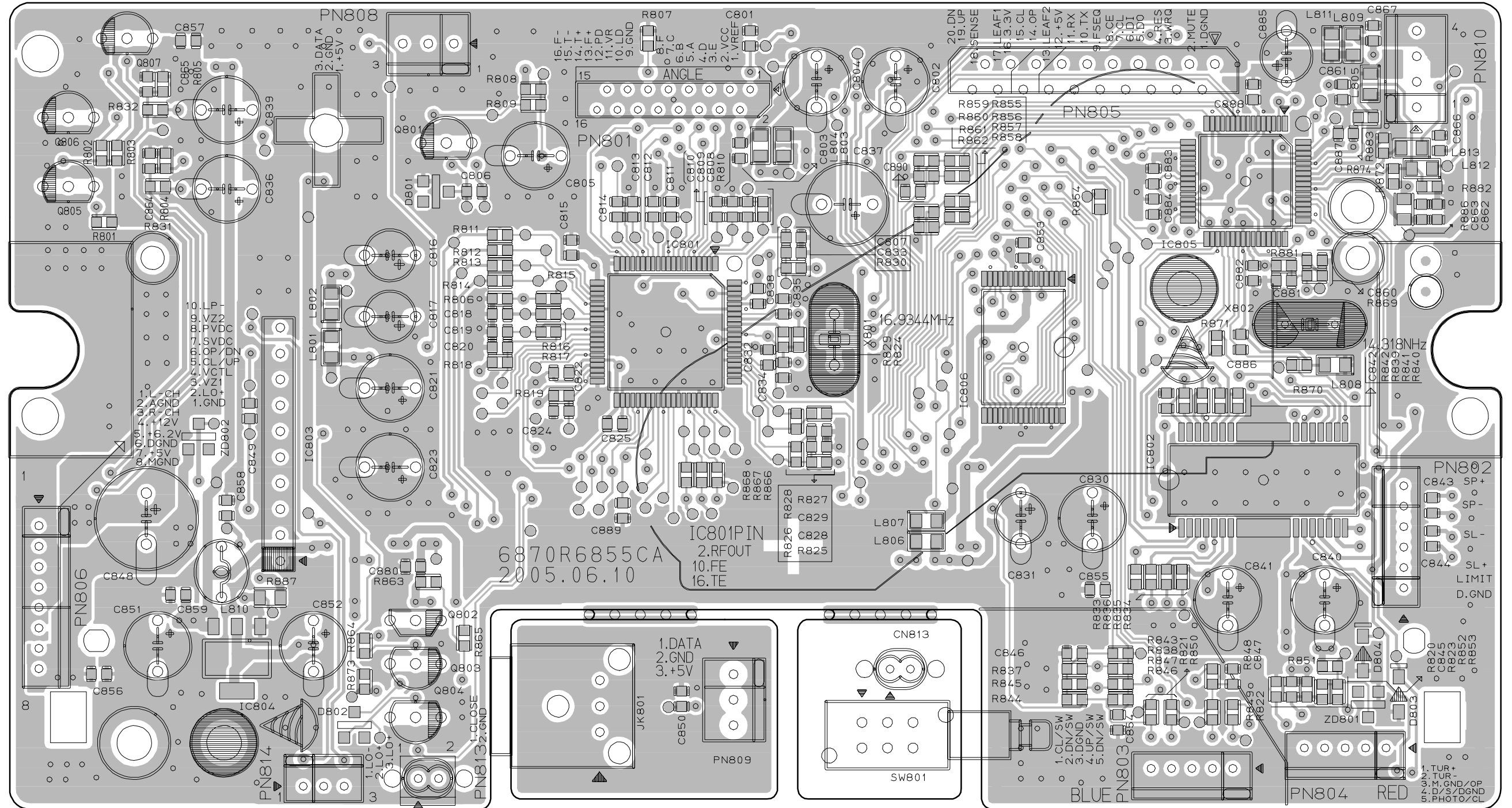

• CDP P.C. BOARD

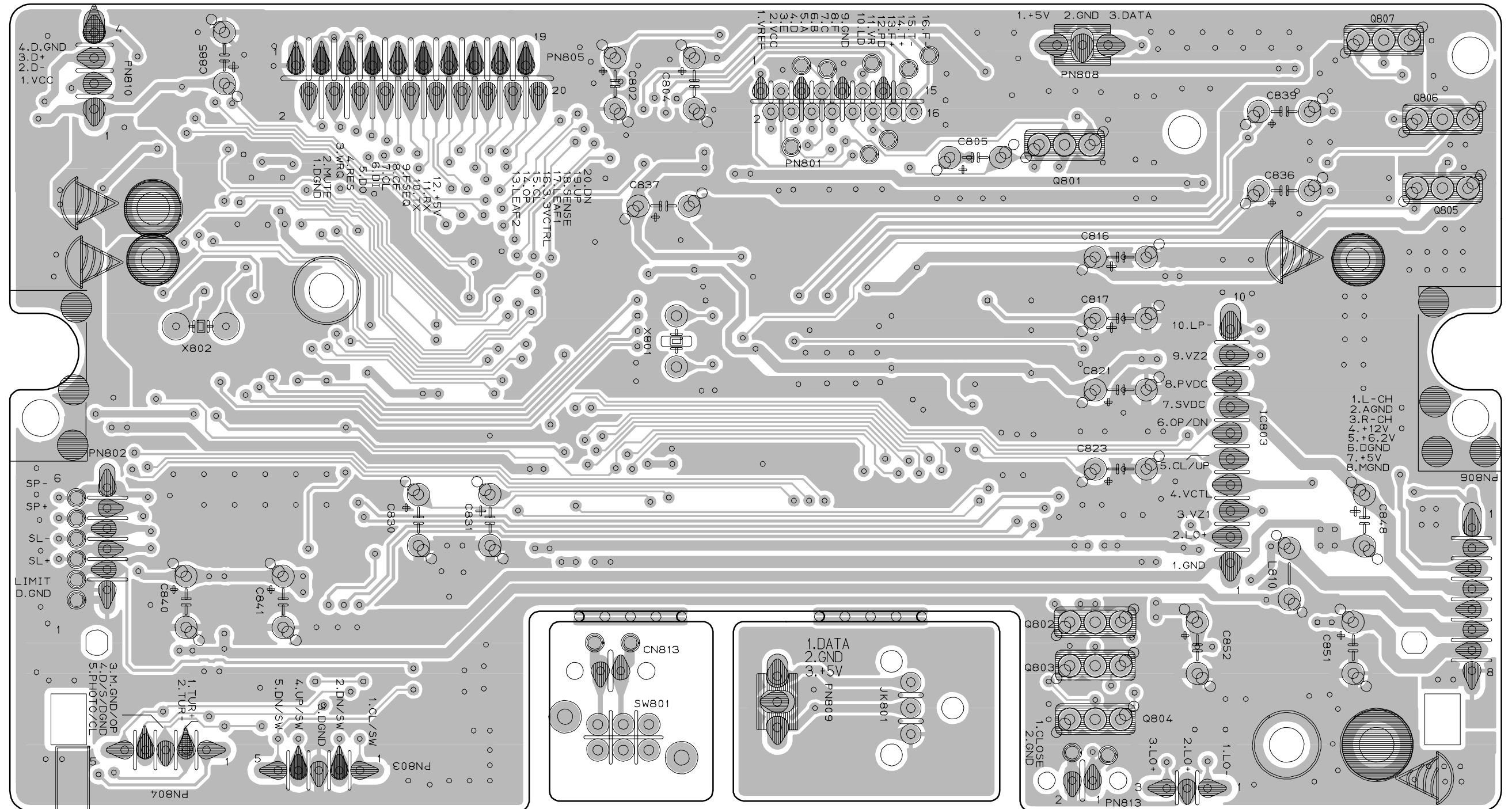

• POWER P.C. BOARD

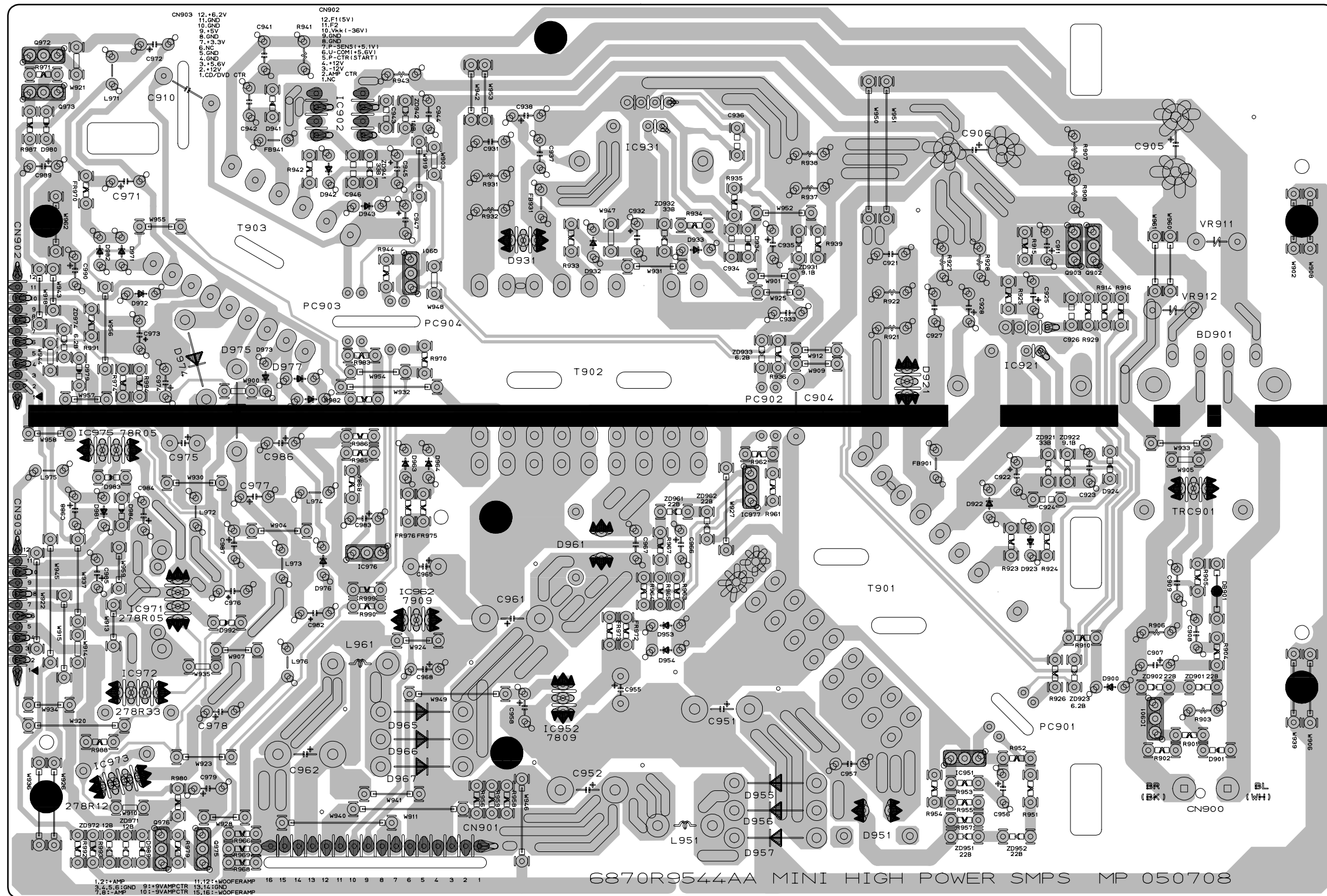

• POWER P.C. BOARD

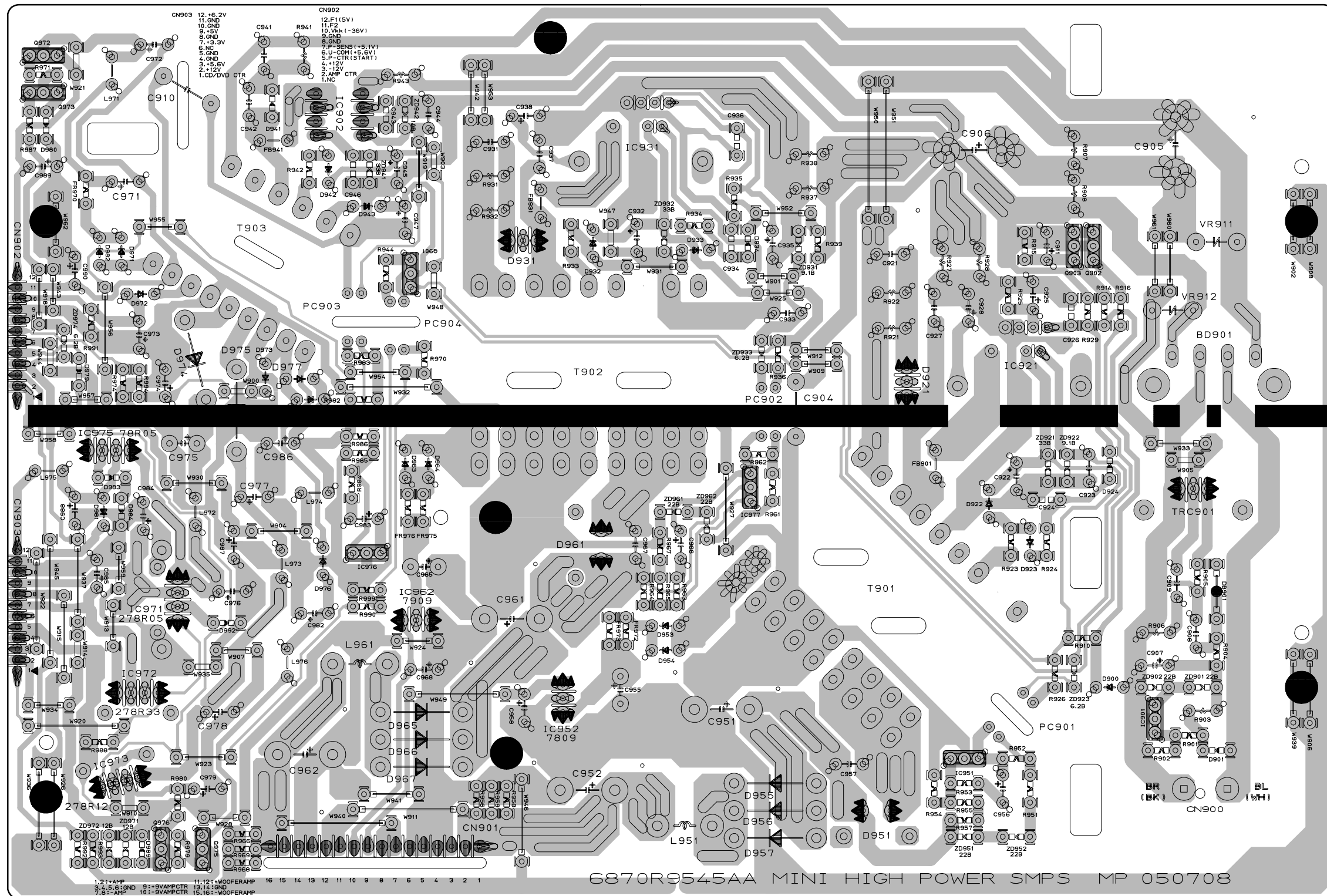

• SUB POWER P.C. BOARD

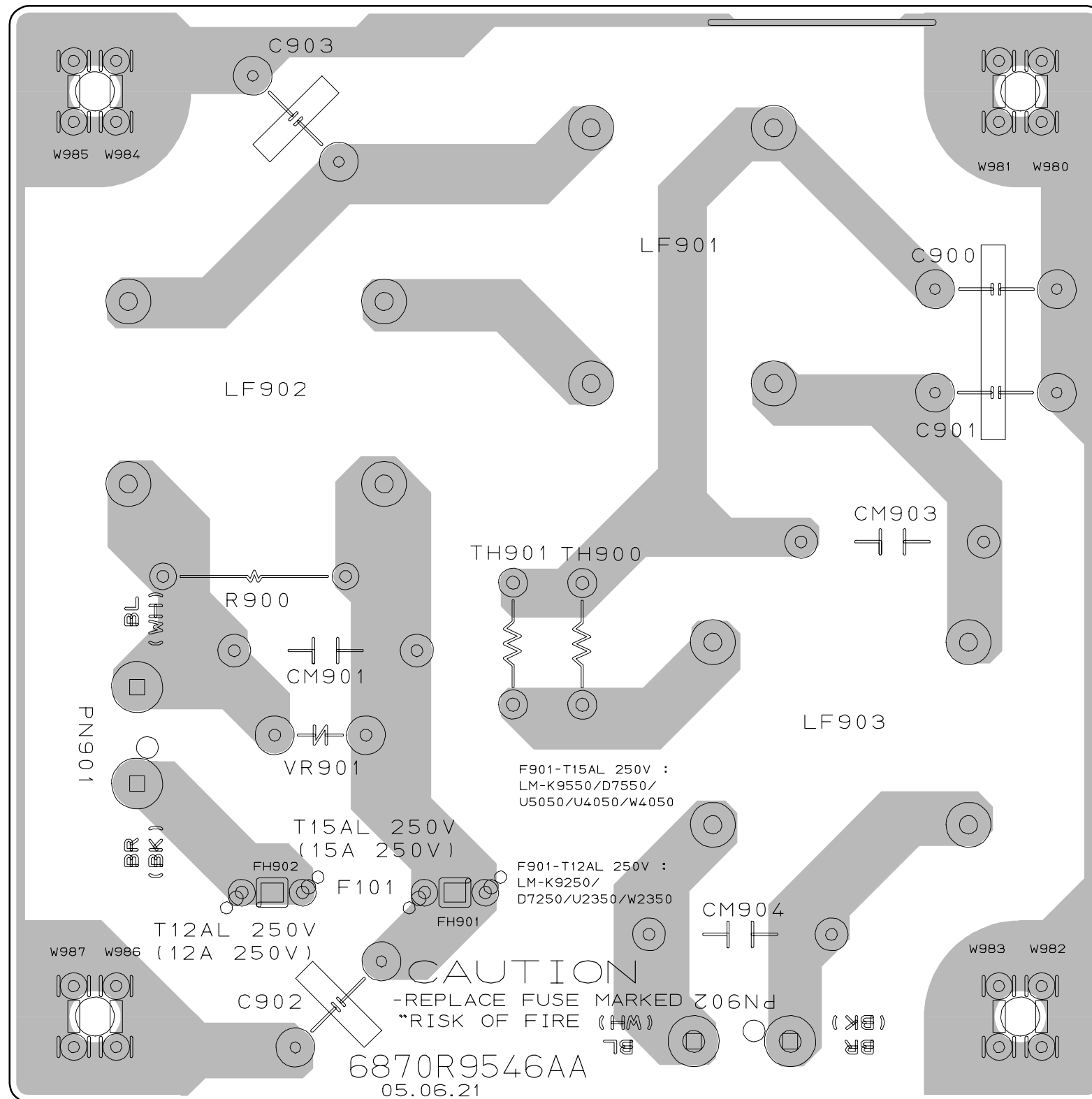

• WOOFER AMP P.C. BOARD

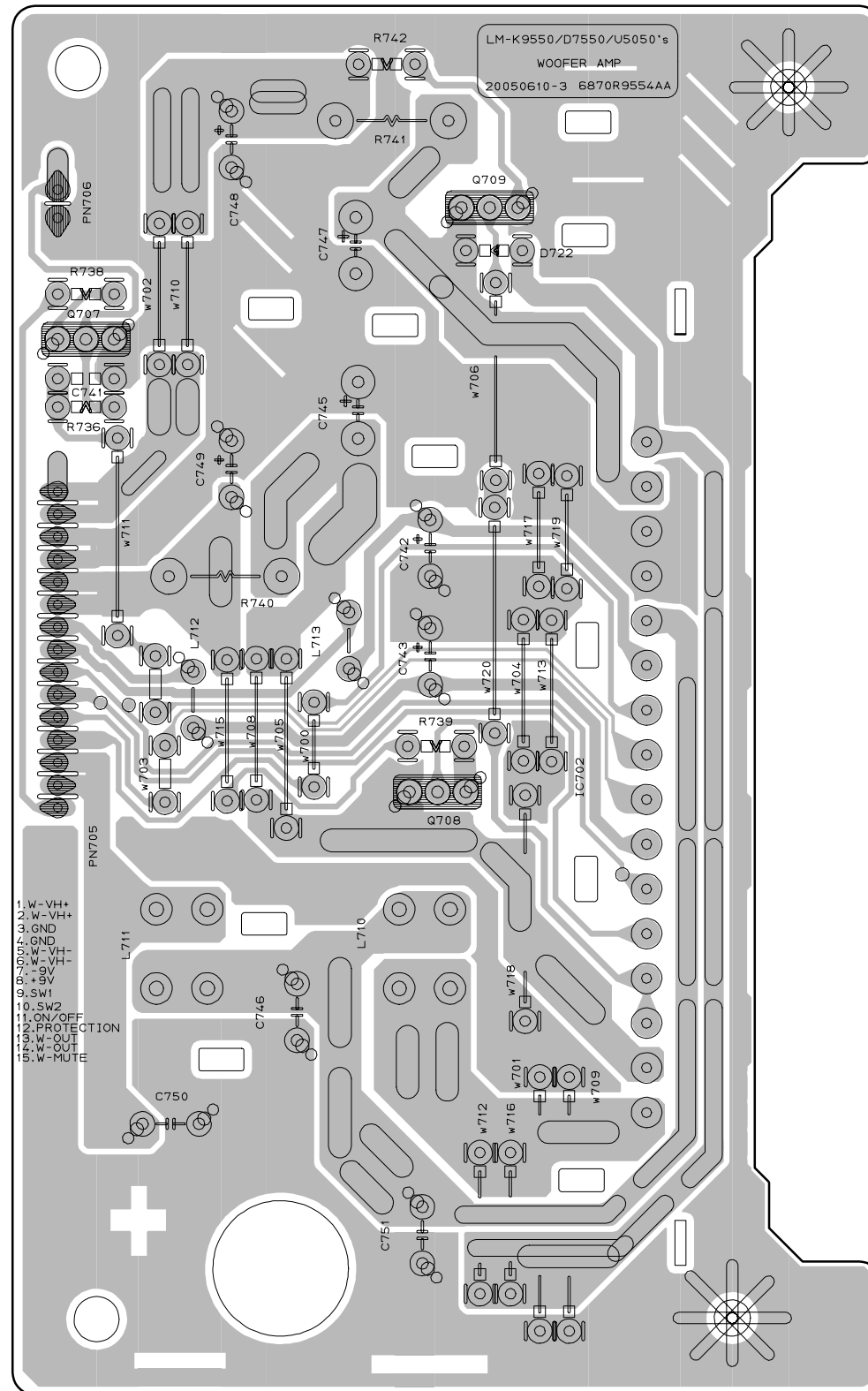

SECTION 3. EXPLODED VIEWS

• CABINET AND MAIN FRAME SECTION

Caution point
A50: Headphone + MIC + USB + Main array assembly pcb.

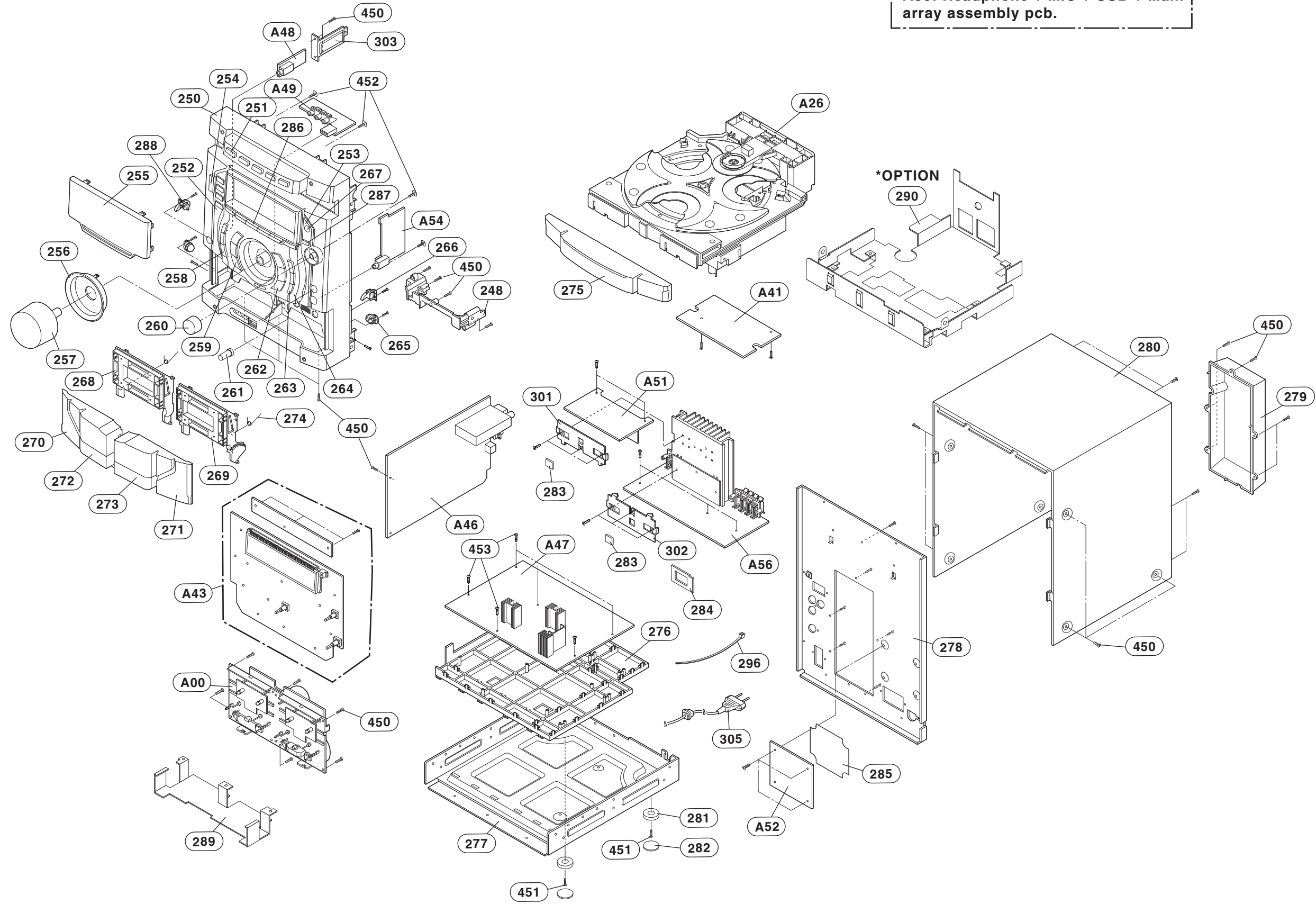

• TAPE DECK MECHANISM (A/R & A/S : RIGHT A/R DECK)

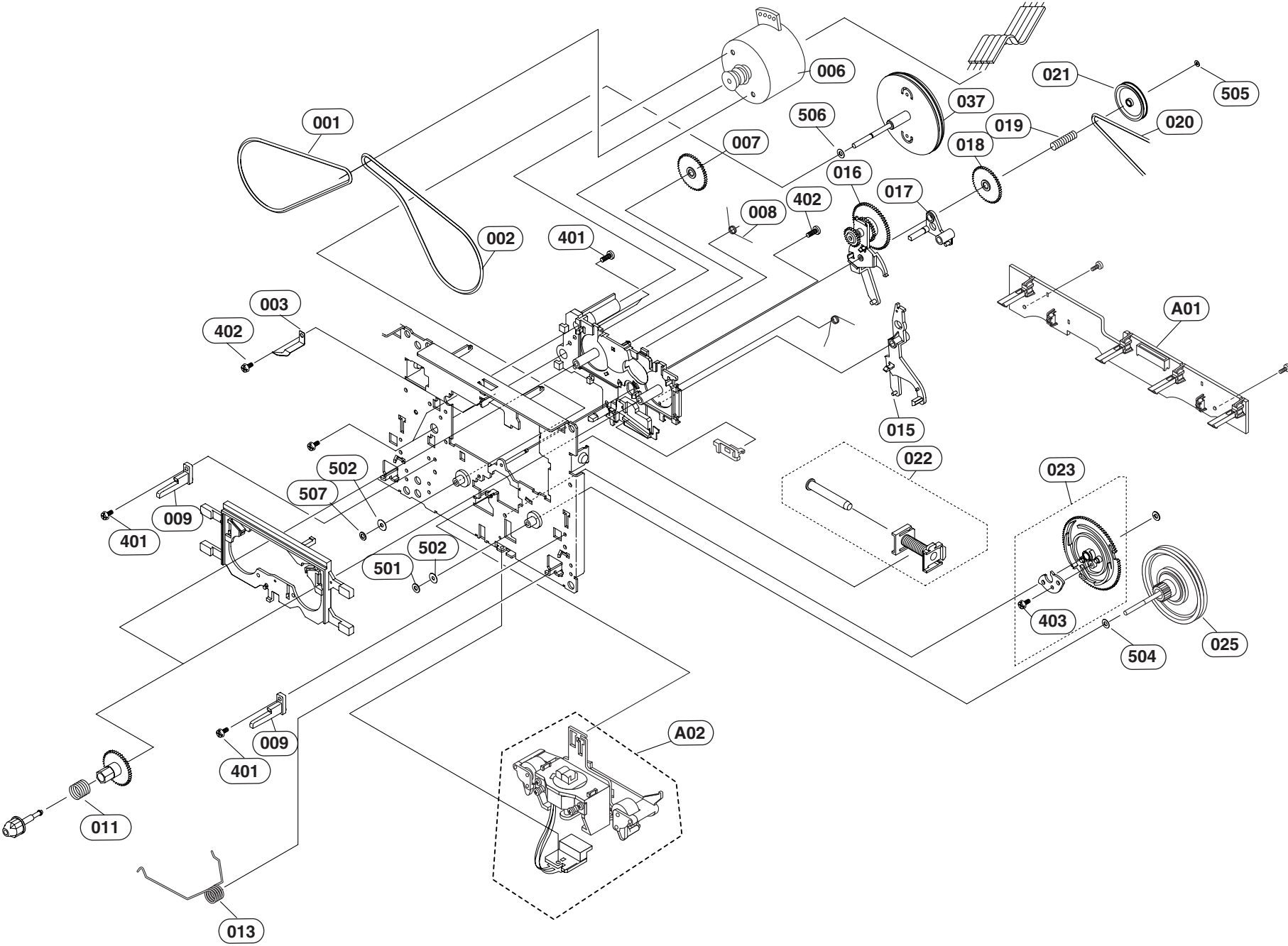

• TAPE DECK MECHANISM (A/R & A/S : LEFT A/R DECK)

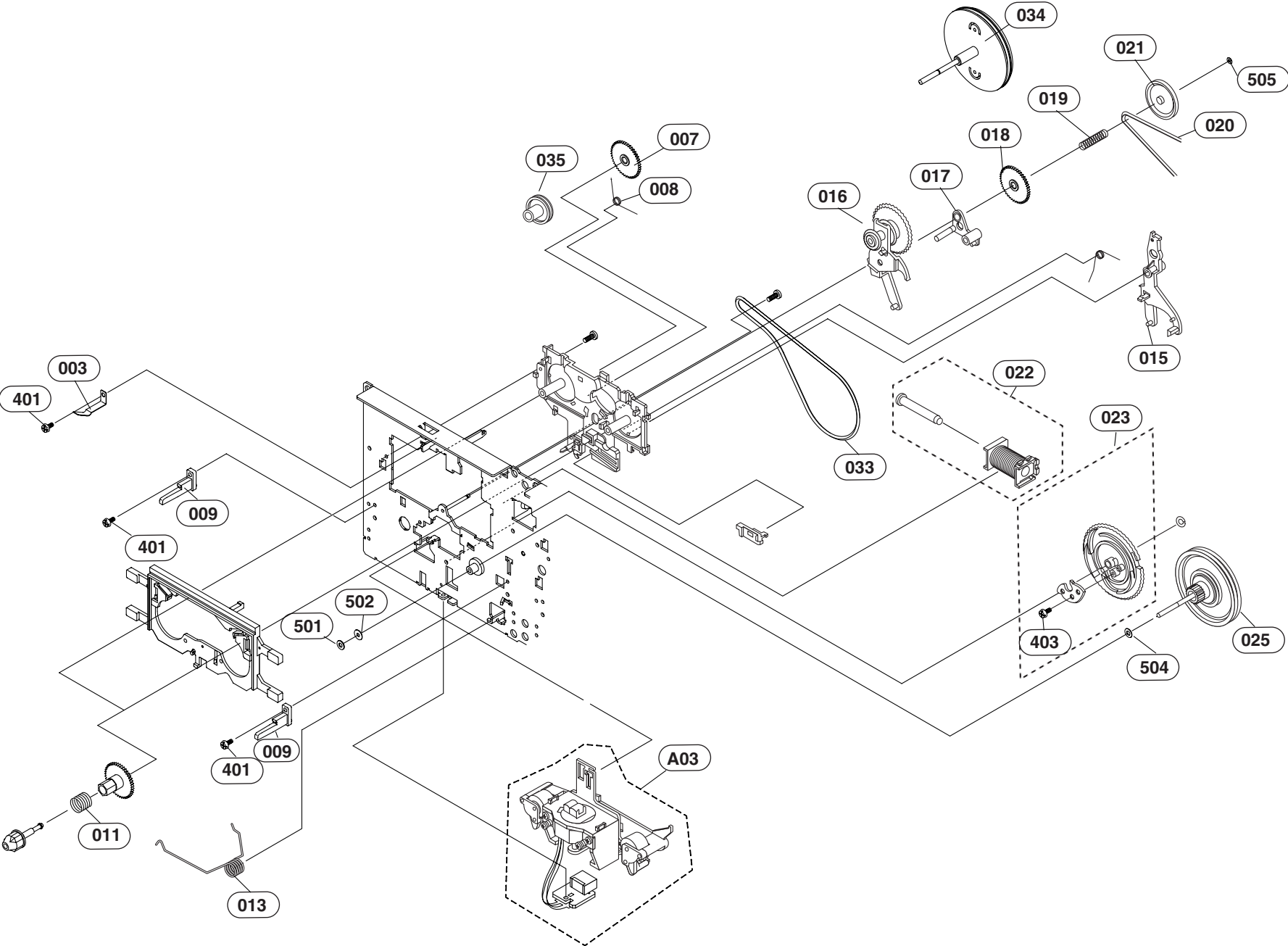

• CD MECHANISM

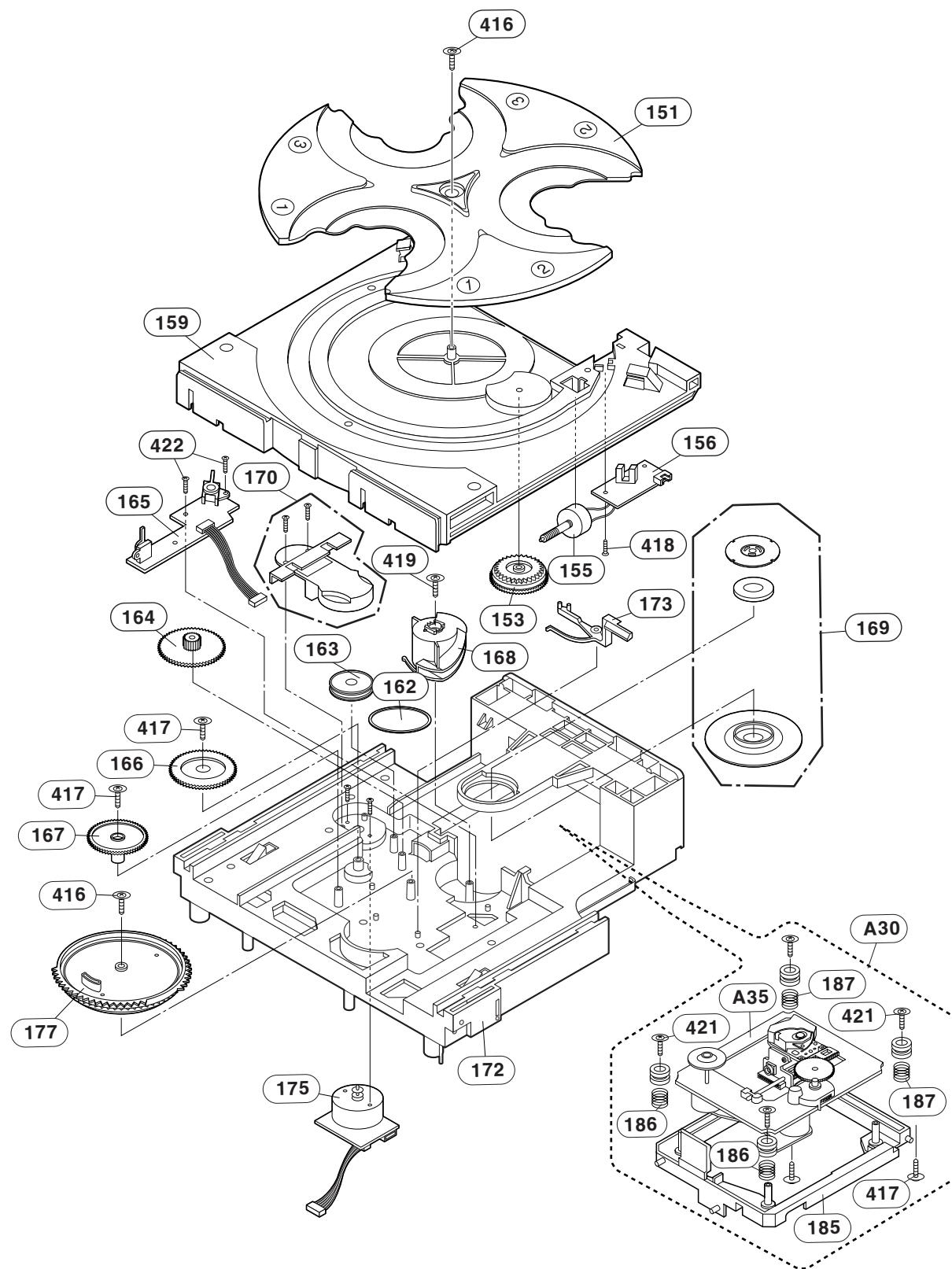

SECTION 4. SPEAKER SECTION

□ MODEL: LMS-U2350, LMS-U4050, LMS-U5050

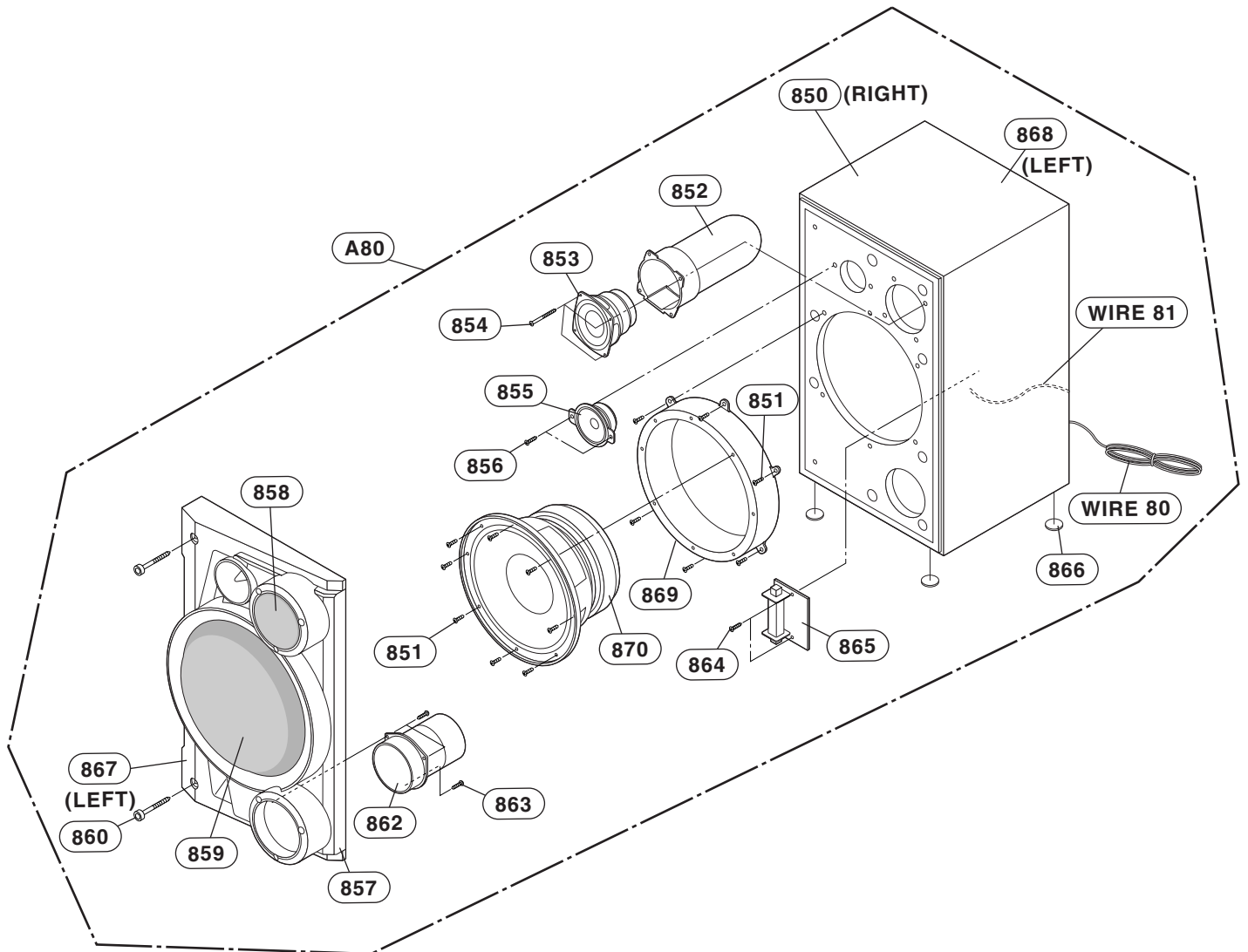

□ MODEL: LMS-U5050W, LMS-U4050W

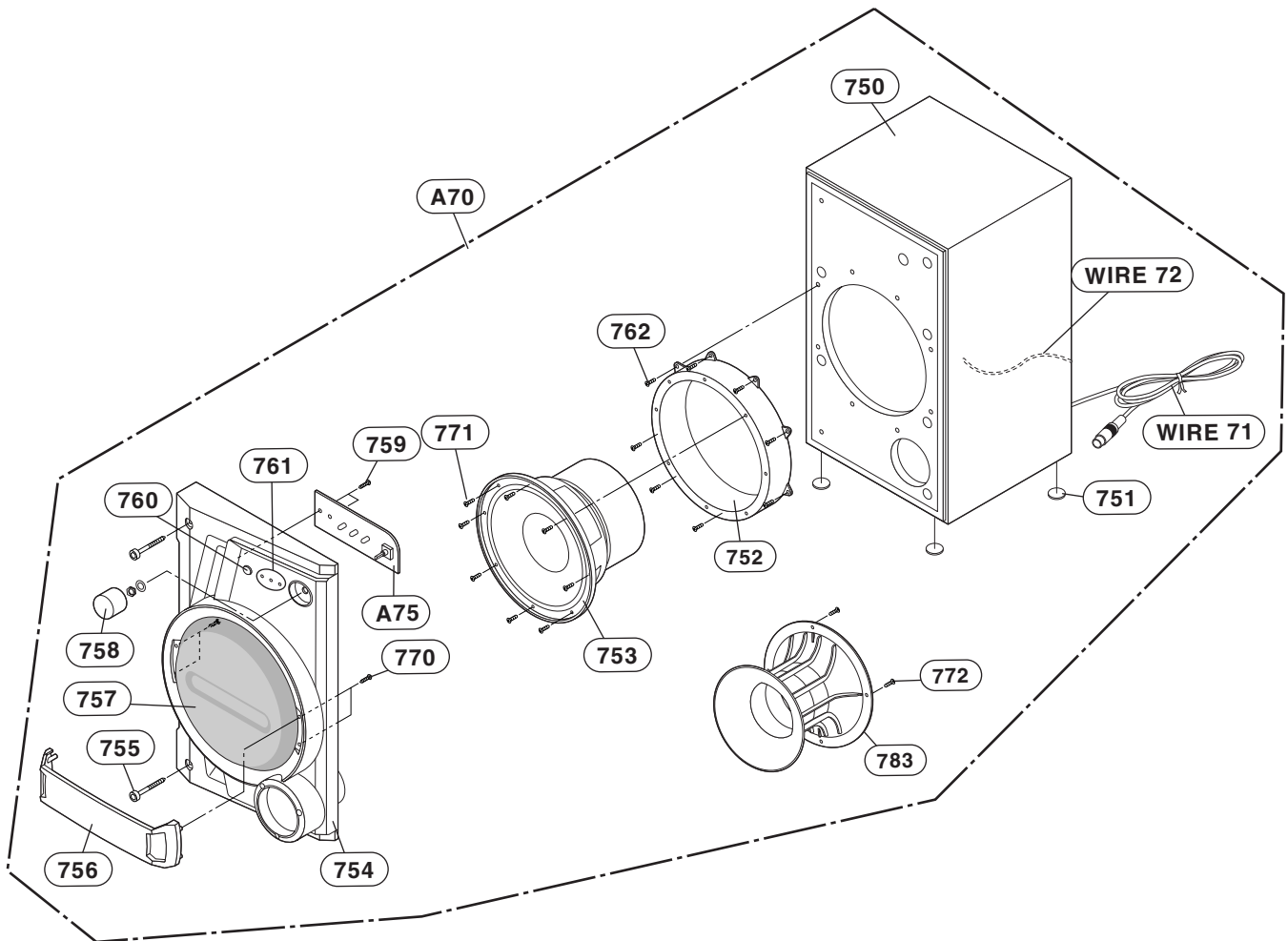

□ MODEL: LMS-U5050S

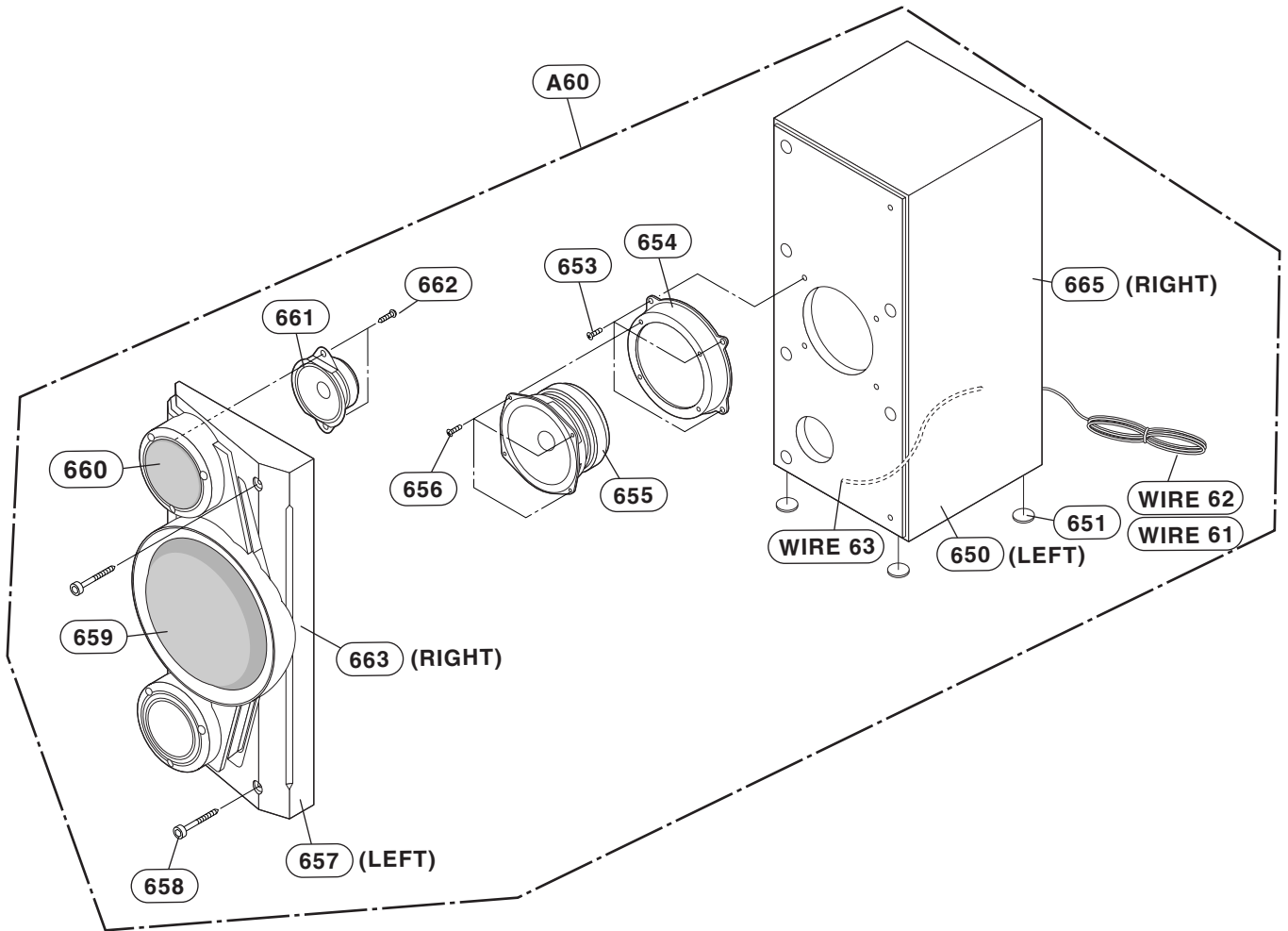

MEMO

A series of horizontal dotted lines spanning the width of the page, intended for handwritten notes.