

[CONTENTS]

○ SECTION 1. GENERAL

- SPECIFICATIONS 1-2

○ SECTION 2. ELECTRICAL

- ADJUSTMENTS 2-1
- TROUBLESHOOTING GUIDIE 2-2
- IC VOLTAGE SHEET 2-17
- BLOCK DIAGRAM 2-21
- SCHEMATIC DIAGRAM 2-23
- PRINTED CIRCUIT DIAGRAMS 2-31
- WIRING DIAGRAM 2-43

○ SECTION 3. EXPLODED VIEWS 3-1

○ SECTION 4. REPLACEMENT PARTS LIST 4-1

SECTION 1. GENERAL

□ SPECIFICATIONS

Remote Control Operation Range

Point the remote control at the remote sensor and press the buttons.

Distance: About 23 ft (7 m) from the front of the remote sensor.

Angle: About 30 ° in each direction of the front of the remote sensor.

SECTION		MODEL	LPC-LM340A/X, LPC-BM340A/X LPC-LM345A/X, LPC-BM345A/X
[General]	Power supply		Refer to the back panel of the unit.
	Power consumption		13W
	Mass		3.24kg
	External dimensions (W x H x D)		360 x 170 x 260mm
	Output Power		2.5W x 2
	Speakers		8Ω x 2
	Battery Operation		DC 12V, eight "C"(R14) and four "AA"(R6) batteries (not supplied)
[CD]	Frequency response		100 ~18000Hz
	Signal-to-noise ratio		59dB
	T.H.D		0.7%
[TUNER]	[FM]	Tuning Range	65~74MHz, 87.5~108MHz or 87.5 ~108MHz
		Intermediate Frequency	10.7MHz
		Antenna	Telescopic antenna
	[AM] (MW)	Tuning Range	522~1611kHz or 530 ~1610kHz
		Intermediate Frequency	450kHz
		Antenna	Ferrite bar antenna
[TAPE]	Recording System		4 Tracks 2 channel stereo
	Frequency Response		125 ~8000Hz
	Signal to Noise Ratio		40/45dB (REC/PLAY)

* Designs and specifications are subject to change without notice.

SECTION 2. ELECTRICAL

□ ADJUSTMENTS

1. TAPE DECK ADJUSTMENT

DECK MODE	TEST TAPE	TEST POINT	ADJUSTMENT	ADJUST FOR	DECK	ADJUST
PLAY BACK	MTT-114	SPEAKER Output	Azimuth adjusting screw	L/R Maximum	STOP	FWD: LEFT
					RVS	FWD: RIGHT RVS: LEFT

2. RECORD BIAS ADJUSTMENT

DECK MODE	TEST TAPE	TEST POINT	ADJUSTMENT	DECK	ADJUST FOR
REC MODE	MTT-5511	C241	L201	AUTO-RVS	85kHz±5kHz
				AUTO-STOP	60kHz±5kHz

❑ TROUBLESHOOTING GUIDE

1. CD

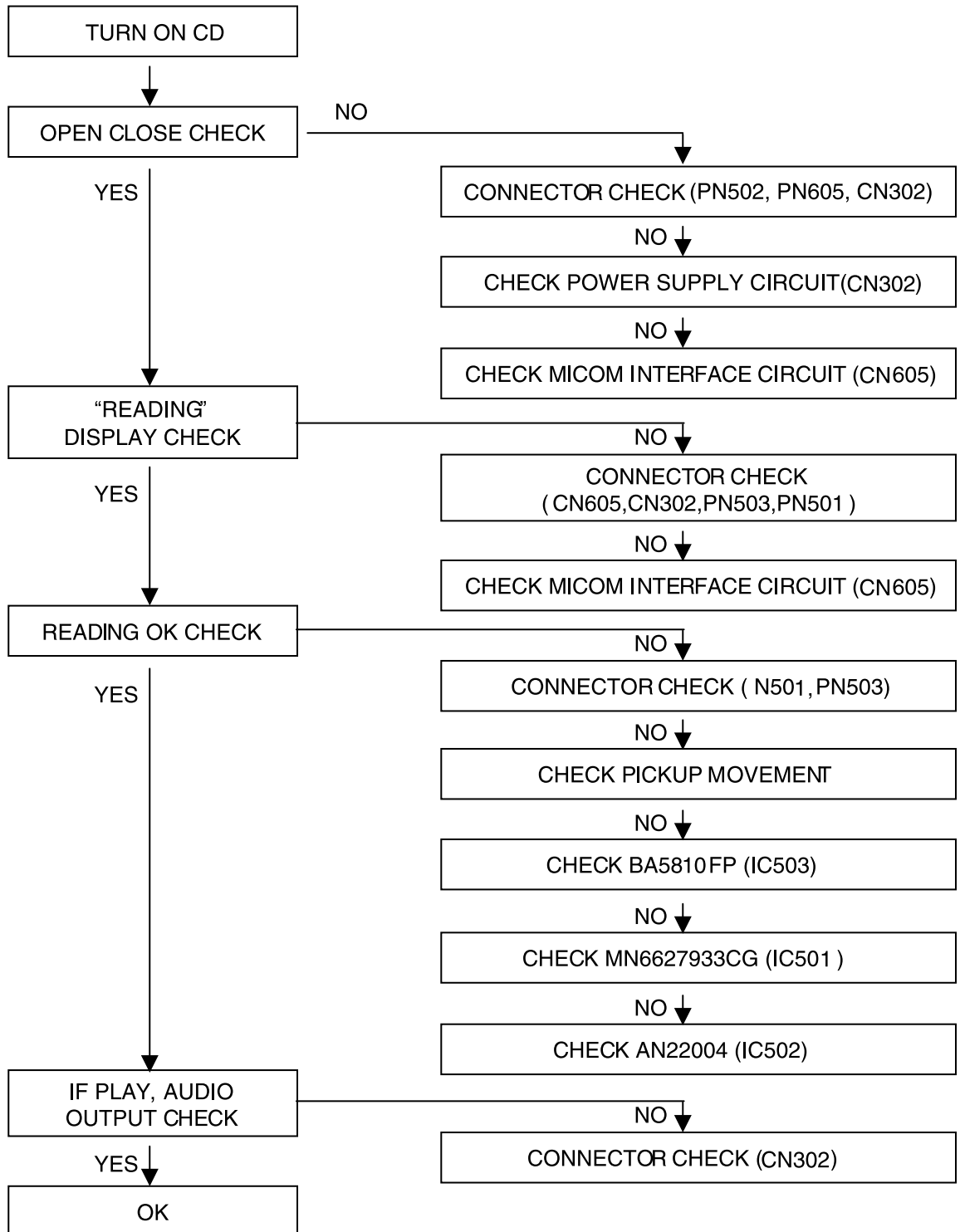

• OPEN COLOSE NG

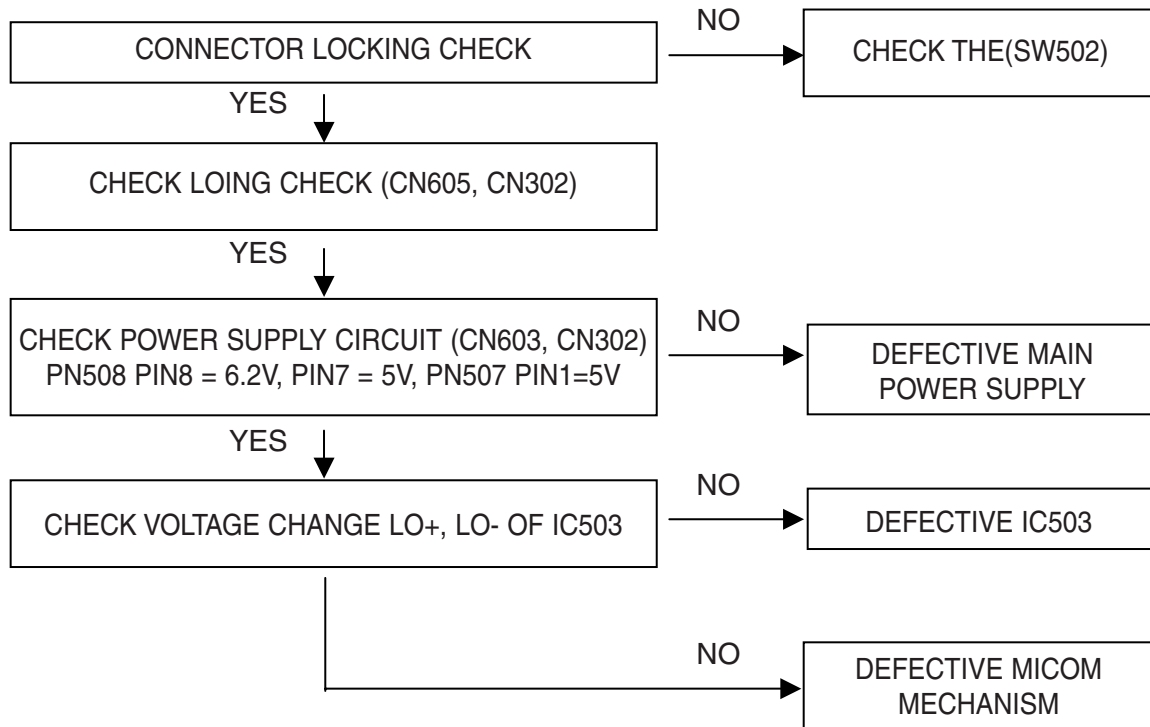

• **“READING” DISPLAY CHECK (=ONLY “CD” DISPLAY)**

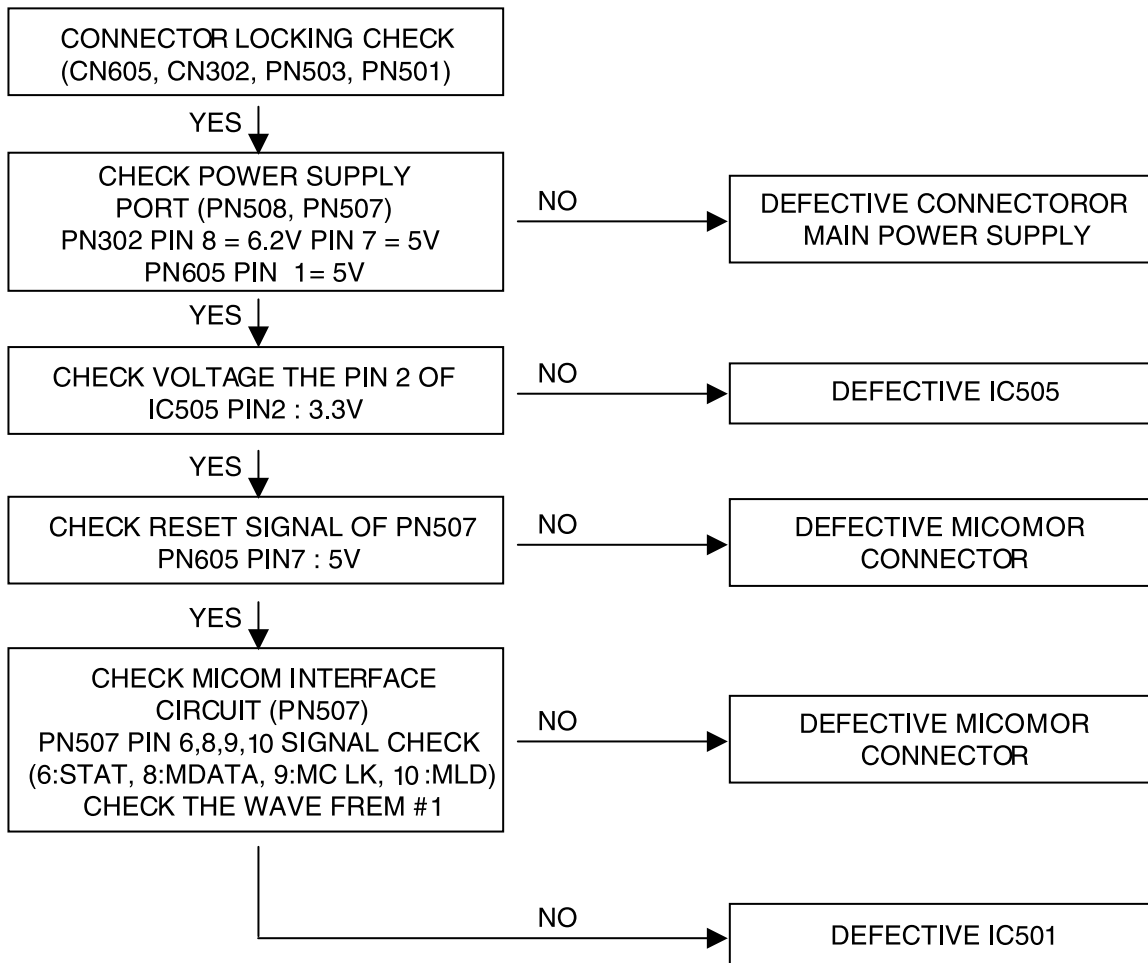

• **READING OK CHECK (= “ NO DISC ” DISPLAY)**

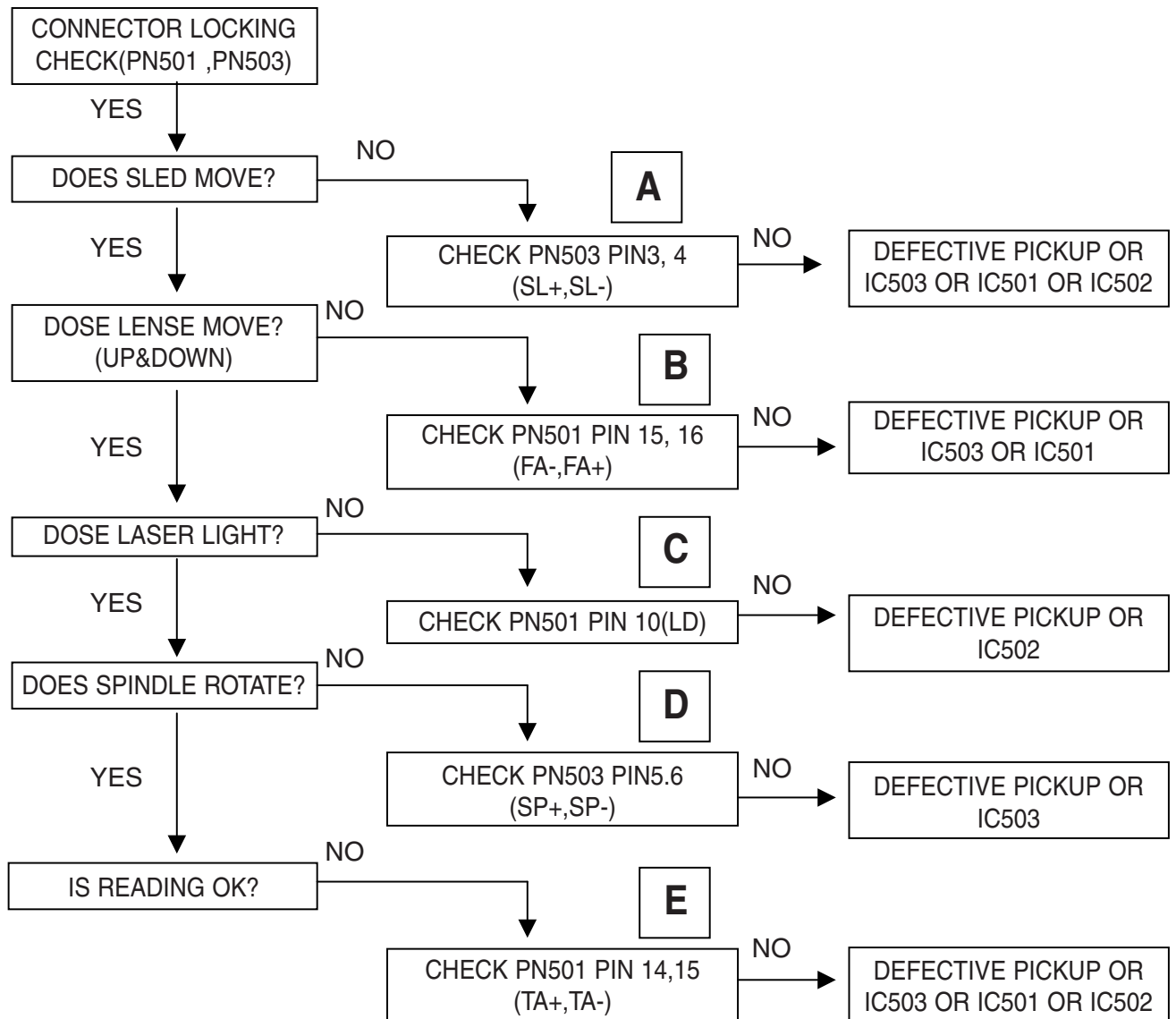

• **READING OK CHECK #A(="NO DISC" DISPLAY)**

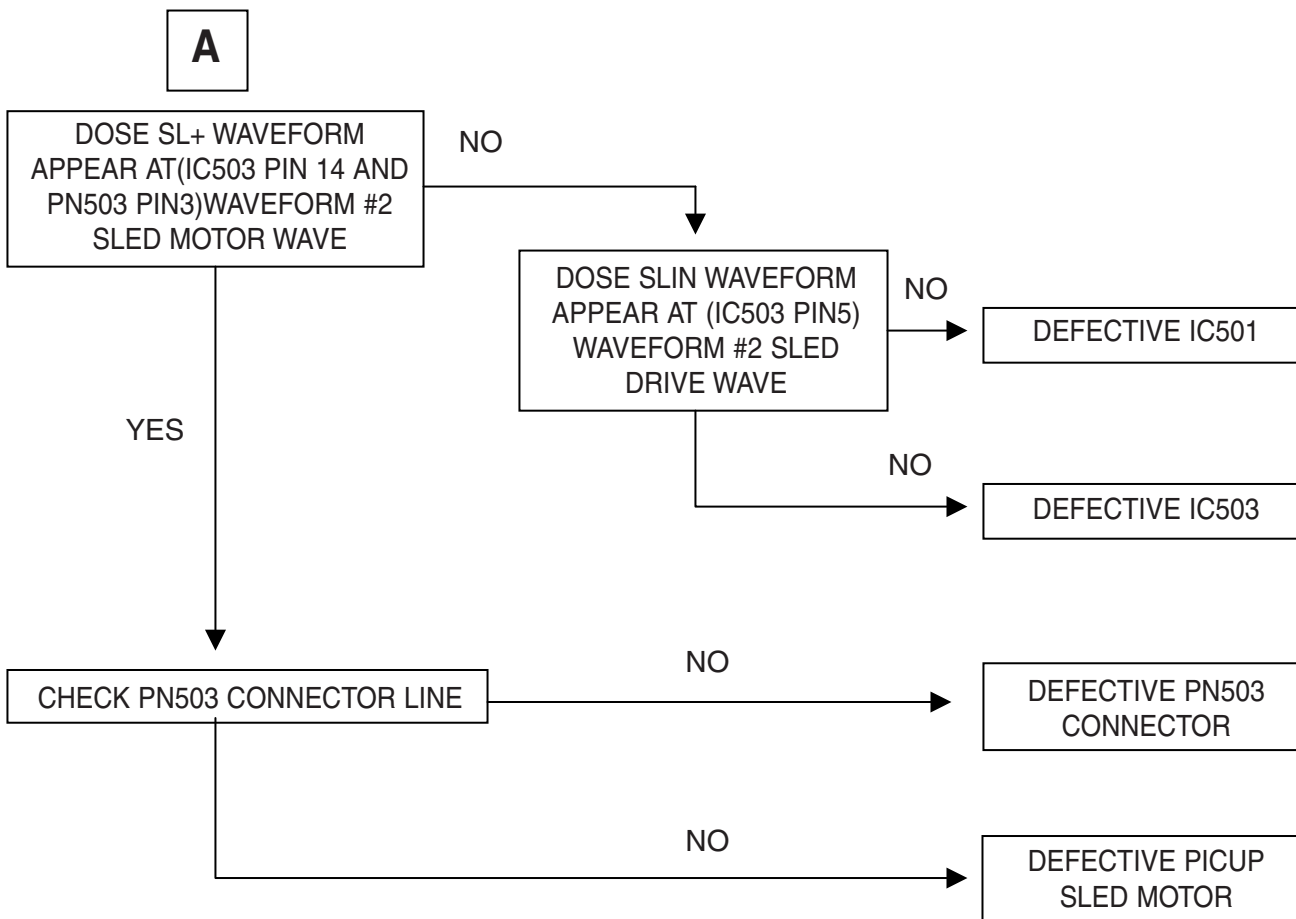

• **READING OK CHECK #B(="NO DISC" DISPLAY)**

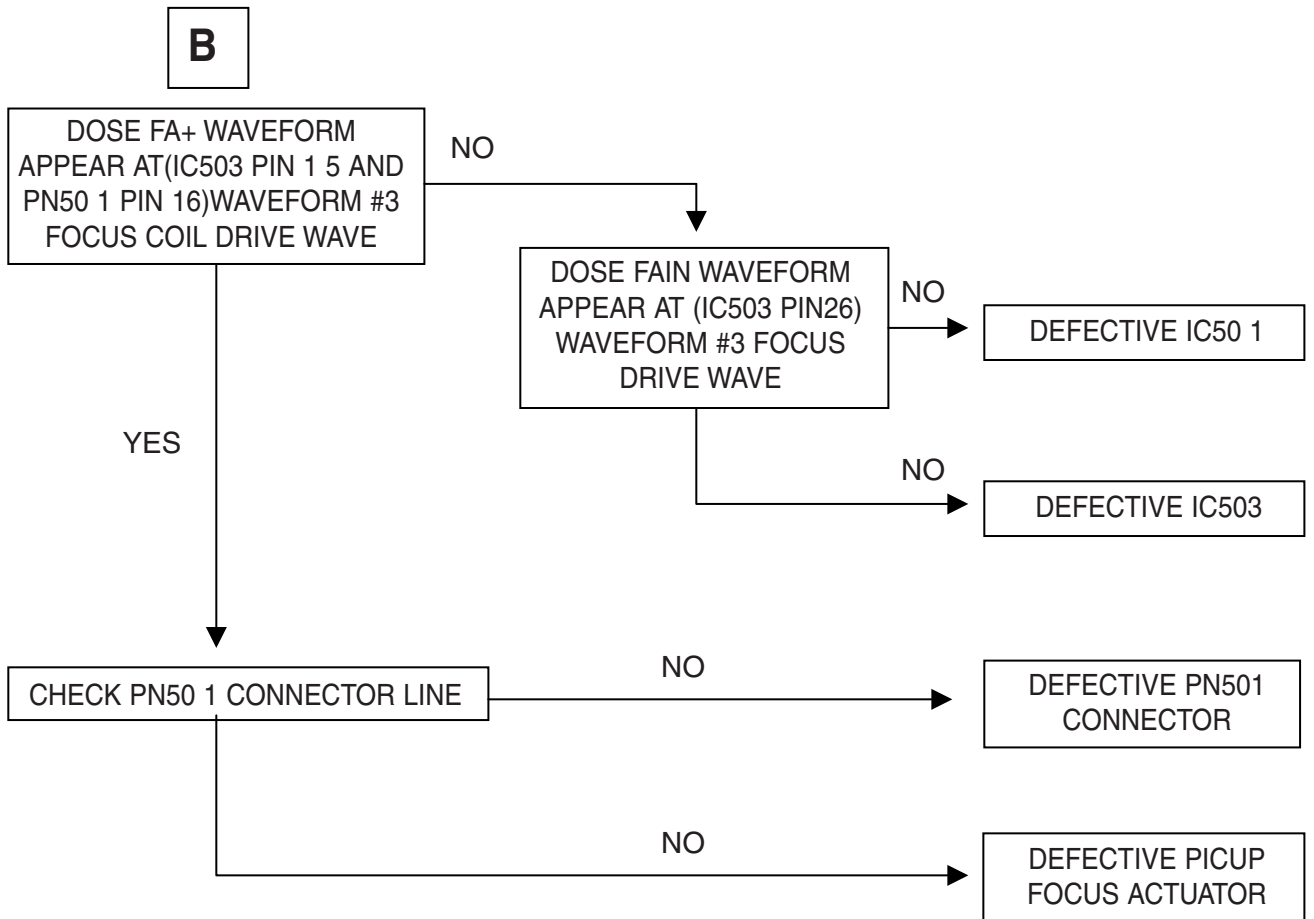

• **READING OK CHECK #C(="NO DISC" DISPLAY)**

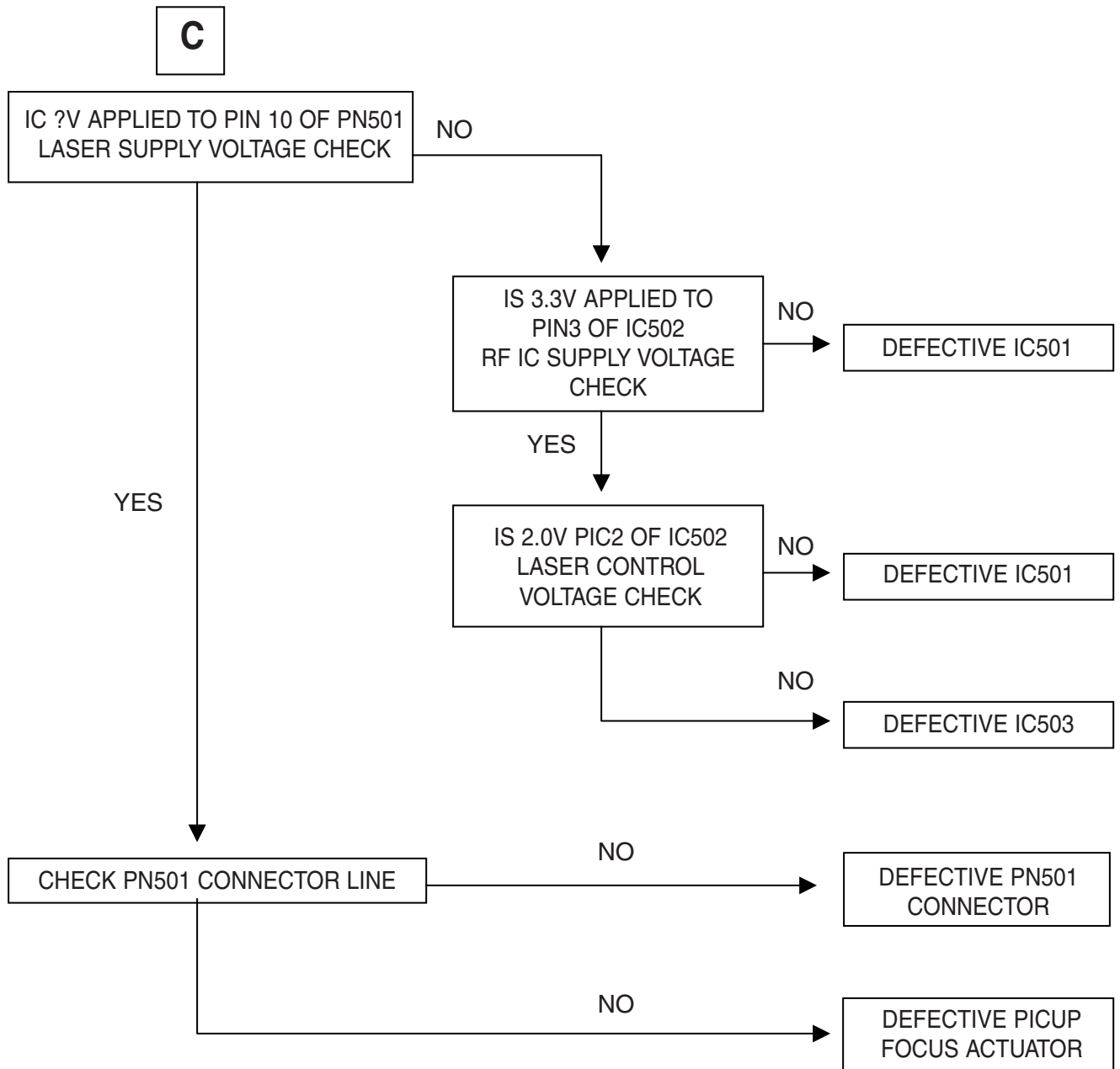

• **READING OK CHECK #D(="NO DISC" DISPLAY)**

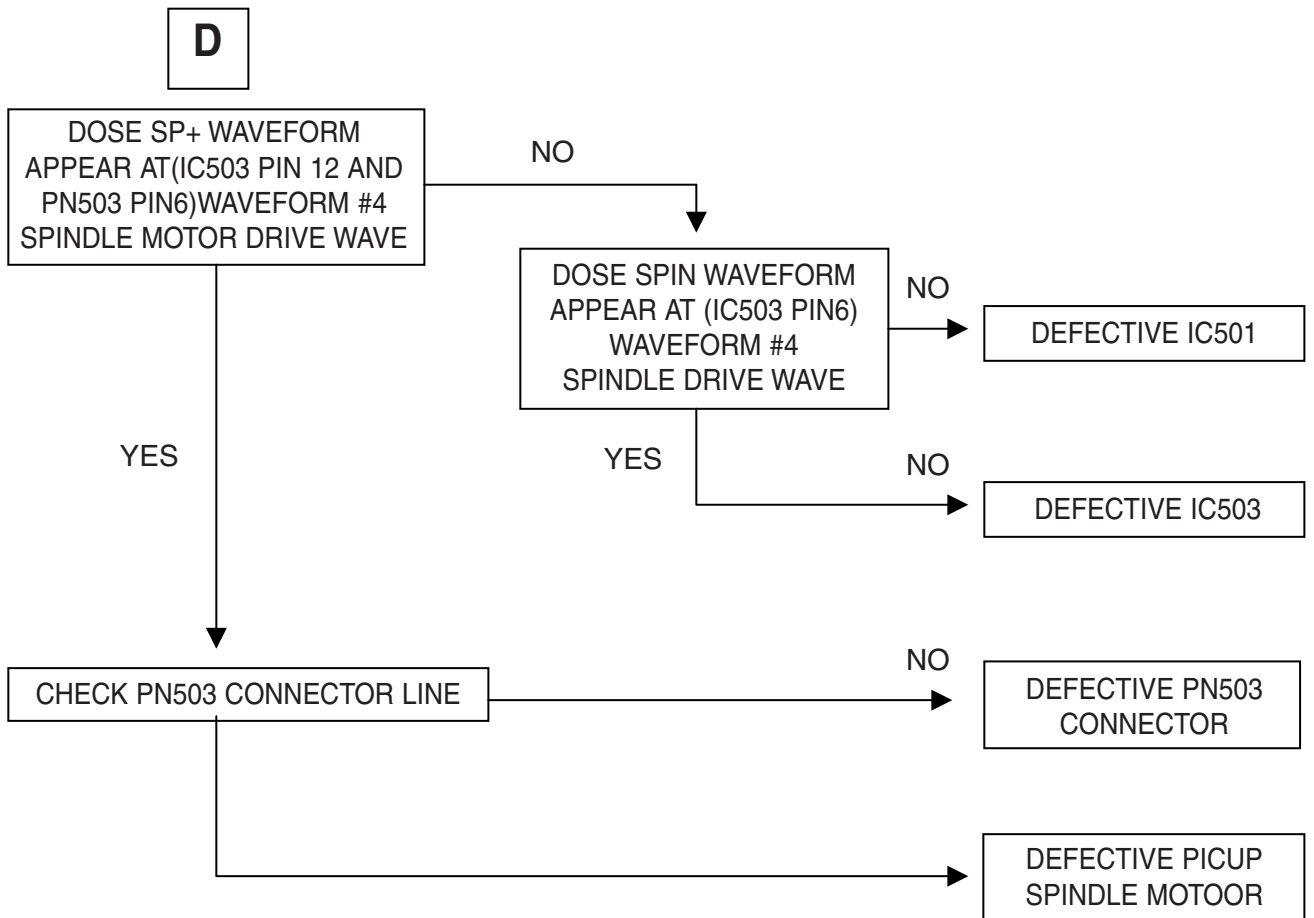

• **READING OK CHECK #E(="NO DISC" DISPLAY)**

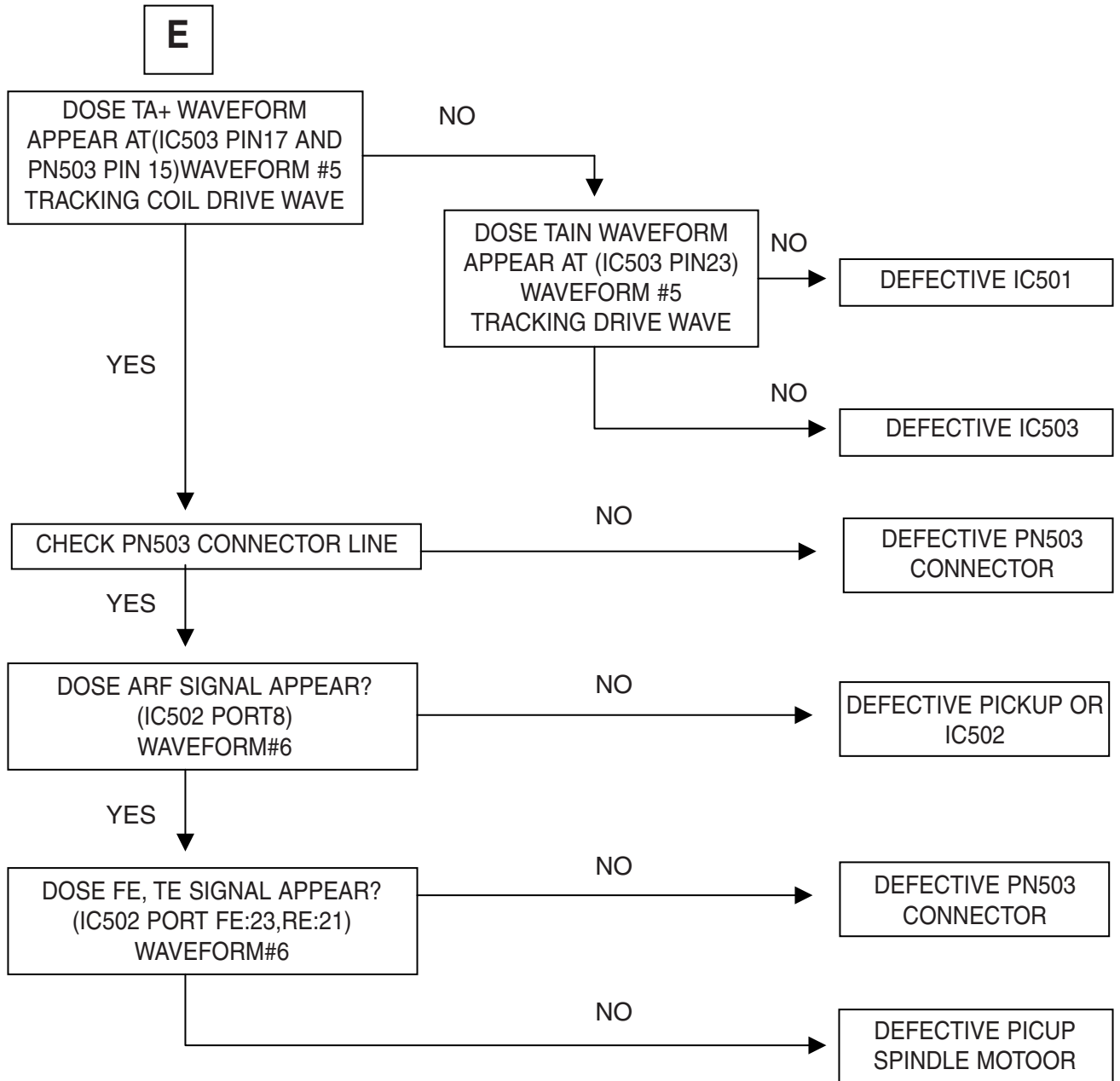

2. MAIN POWER

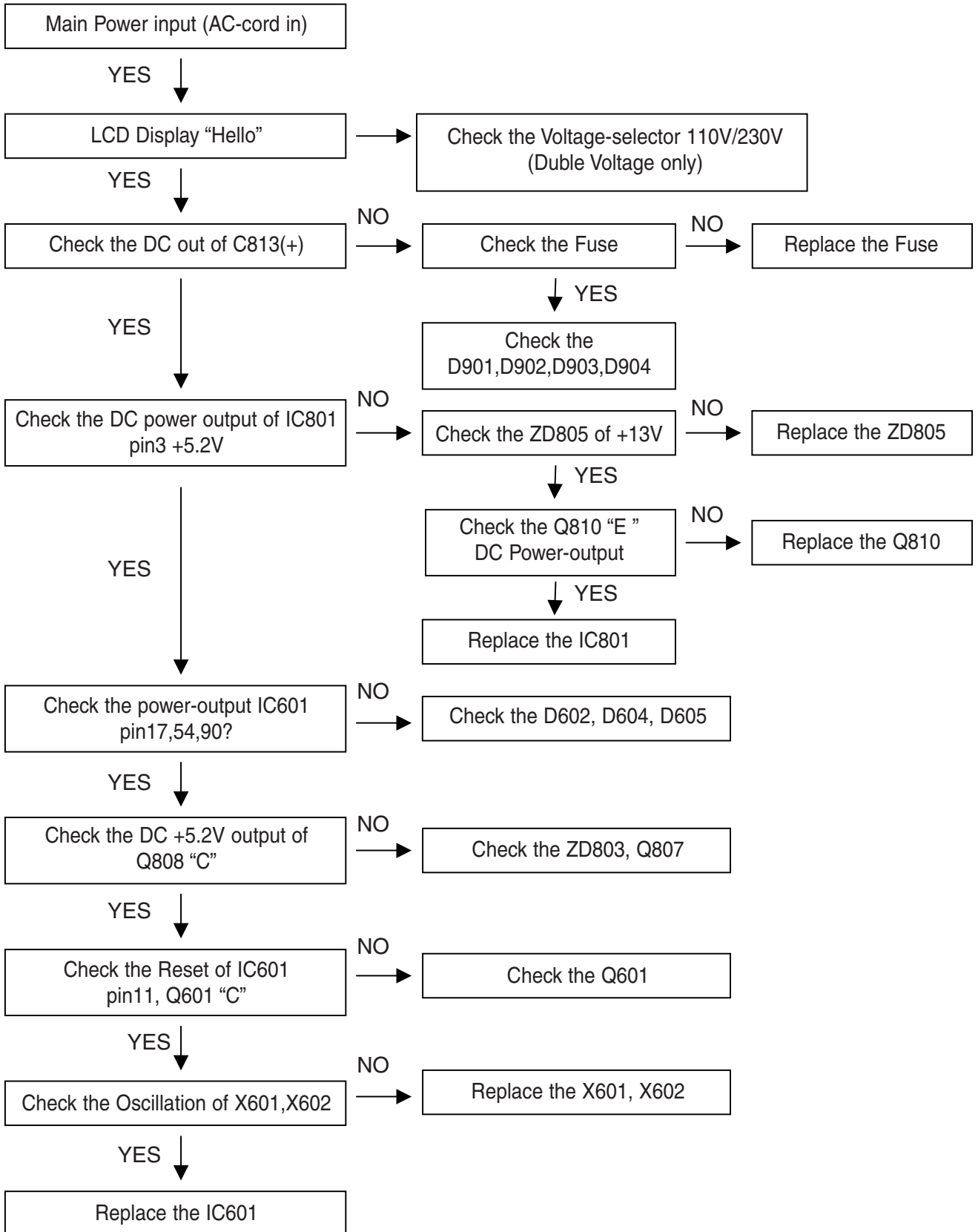

3. MUTING CIRCUIT(MUTE)

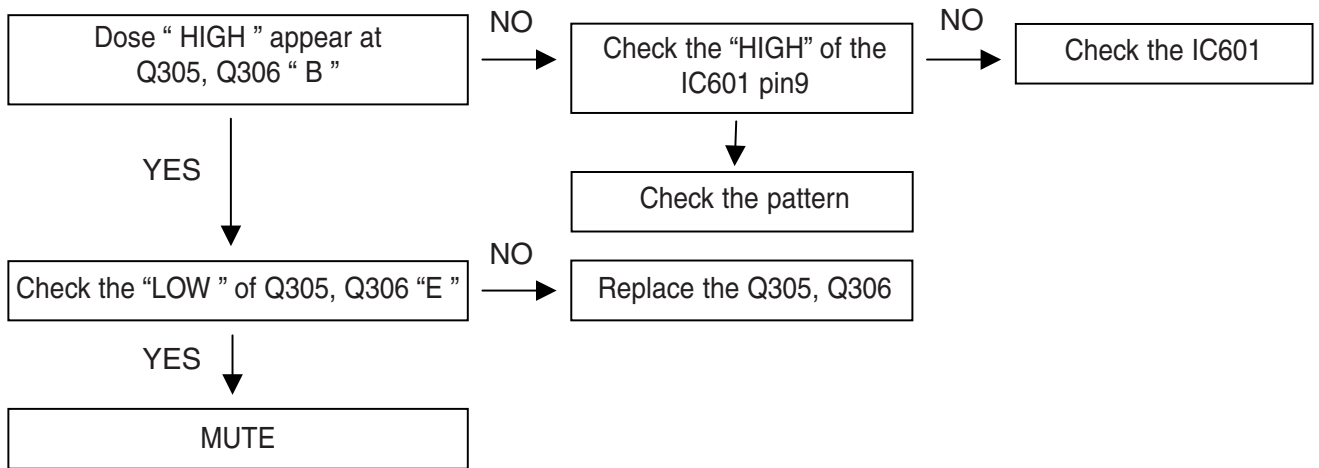

4. FUNCTION MODE AUDIO ABNORMAL

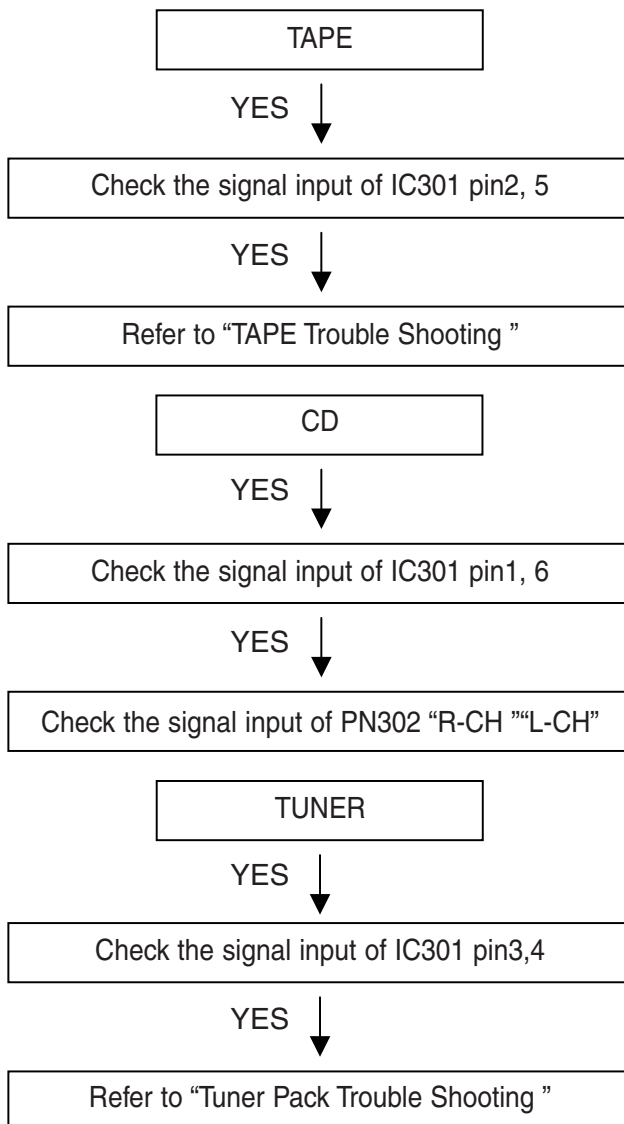

5. IC301

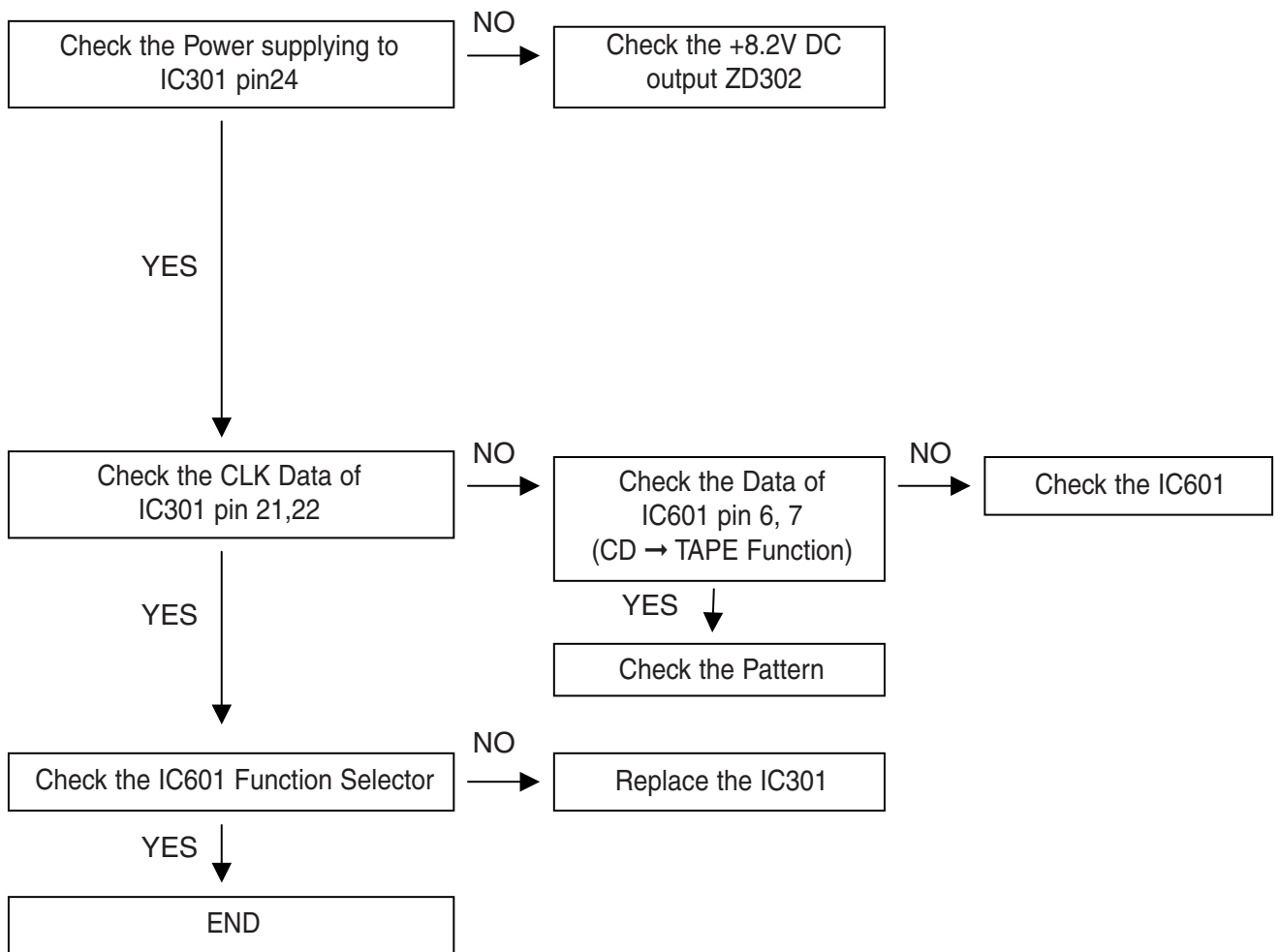

6. TUNER PACK

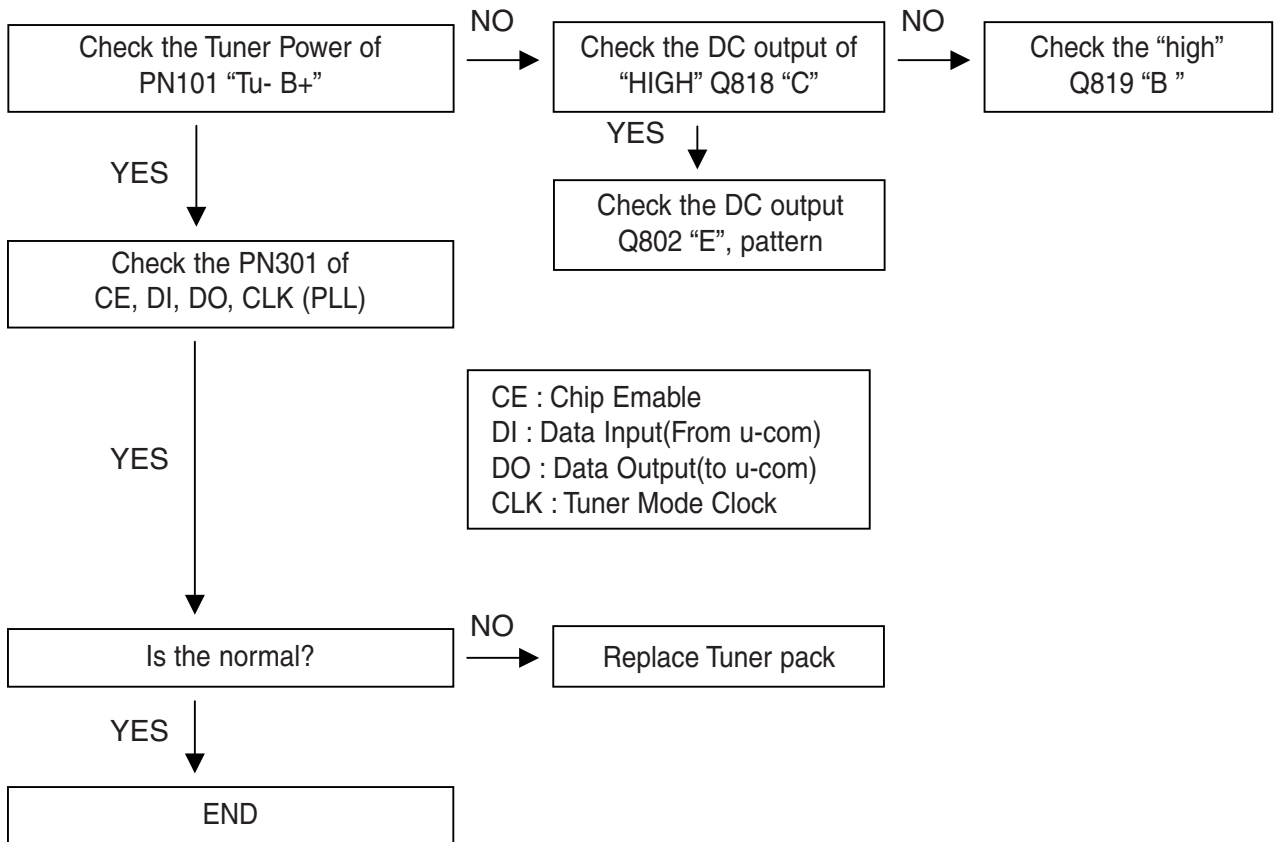

7. TAPE DECK

[Play]

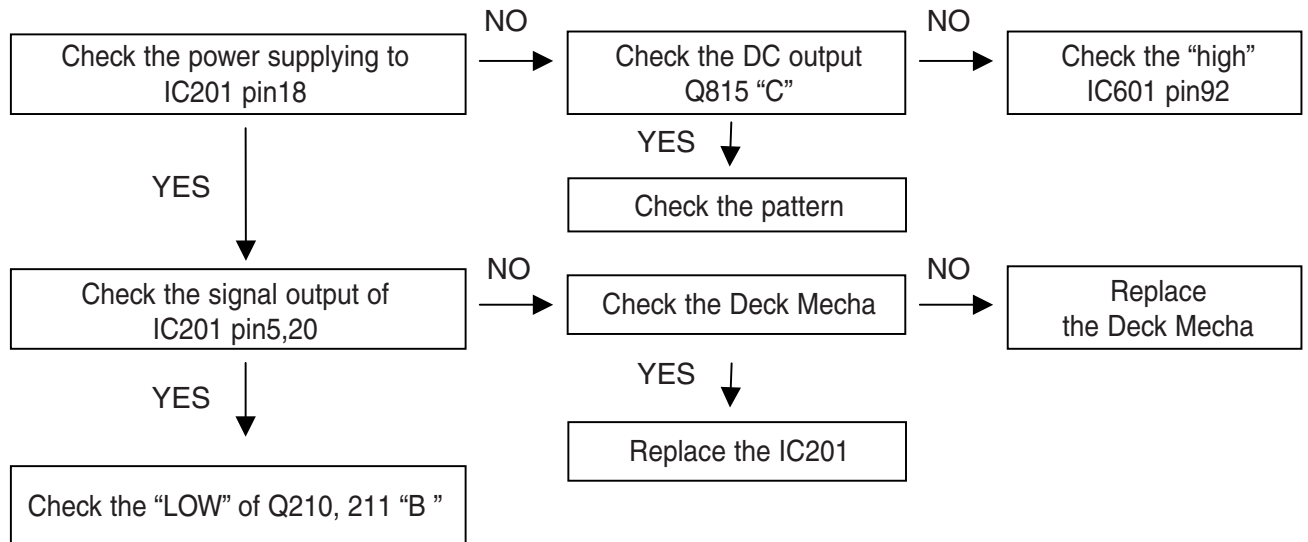

[REC]

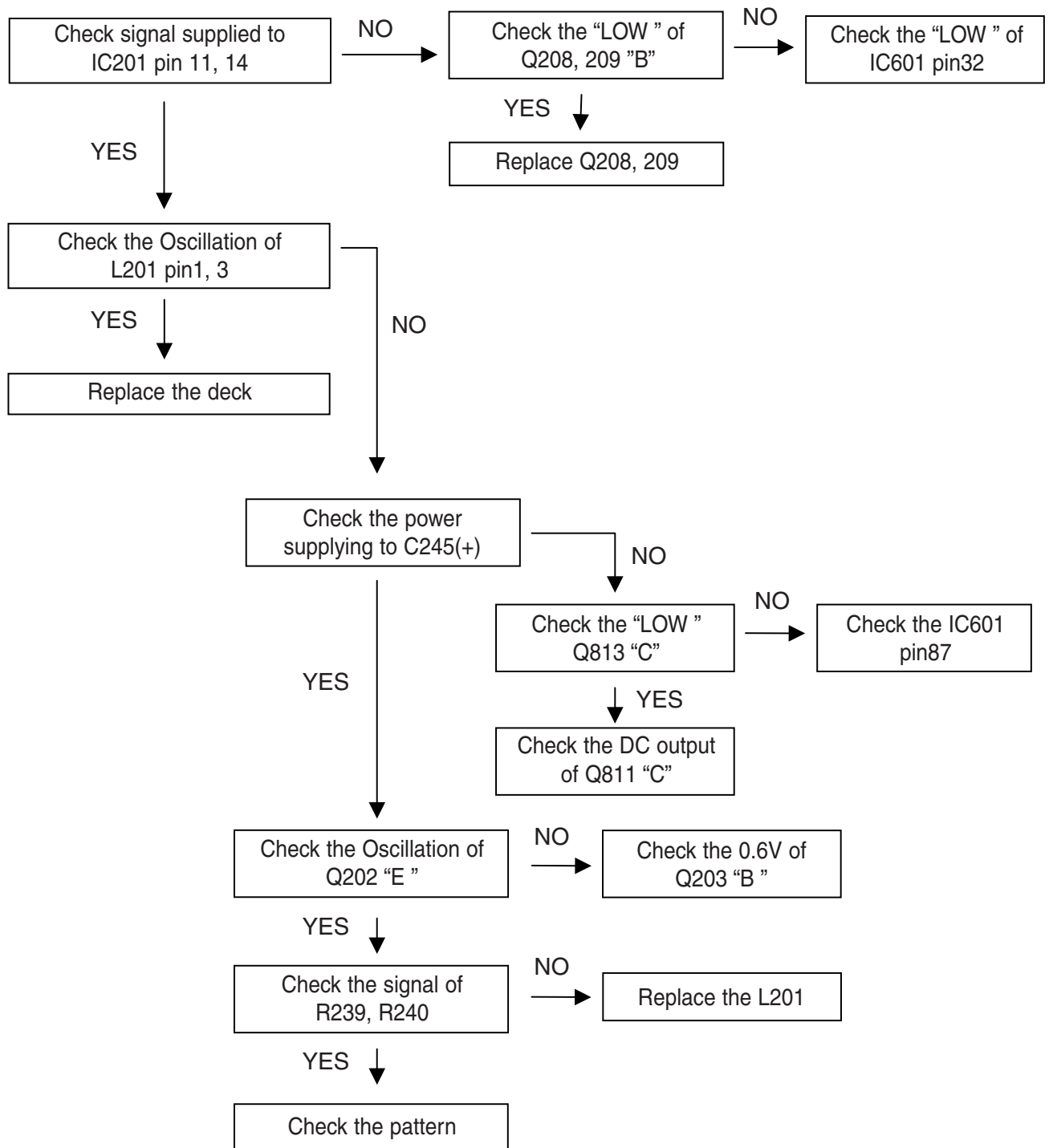

□ VOLTAGE SHEET

• IC201

1	2	3	4	5	6	7	8	9	10	11	12
0V	0V	1.3V	1.3V	1.4V	1.7V	0V	4.5V	2V	1.3V	0V	0V
13	14	15	16	17	18	19	20	21	22	23	24
0.8V	0V	1.3V	2V	1.4V	7.8V	7.5V	4V	1.3V	1.3V	0V	0V

• IC202

1	2	3	4	5	6	7	8
0V	0V	0V	5V	0V	7.8V	0V	0V

• IC301

1	2	3	4	5	6	7	8	9	10	11	12
3.9V	4.1V	4.1V	4.1V	4.1V	3.9V	4.1V	4.1V	4.1V	4.1V	4.1V	4.1V
13	14	15	16	17	18	19	20	21	22	23	24
4.1V	4.1V	4.1V	0V	0V	4.1V	4.1V	0V	0V	0V	4.1V	8.2V
25	26	27	28								
0V	3.4V	3.4V	4.1V								

• IC302

1	2	3	4	5	6	7	8	9	10	11	12
10.7V	6.1V	11V	5.8V	0.4V	0V	0V	0.7V	0V	9.1V	10.8V	12V

• IC501

1	2	3	4	5	6	7	8	9	10	11	12
0V	0V	0V	0V	3.3V	0V	0V	0V	0V	0V	0V	0V
13	14	15	16	17	18	19	20	21	22	23	24
0V	3.3V	3.3V	0V	0V	0V	0V	0V	0V	0V	0V	0V
25	26	27	28	29	30	31	32	33	34	35	36
0V	0V	0V	1.5V	1.5V	0V	0V	0V	0V	0V	1.6V	0V
37	38	39	40	41	42	43	44	45	46	47	48
1.7V	0V	3.3V	1.6V	1.6V	1.6V	1.6V	1.6V	1.6V	3.2V	0V	0V
49	50	51	52	53	54	55	56	57	58	59	60
0V	3.2V	0.8V	1.6V	1.6V	3.2V	1.4V	1.4V	0V	1.6V	0V	1.6V
61	62	63	64	65	66	67	68	69	70	71	72
3.2V	0V	0V	0V	0V	0V	1.5V	0V	0V	0V	0V	2.5V
73	74	75	76	77	78	79	80	81	82	83	84
0.25V	2.7V	0.25V	0V	0V	0V	1.6V	0V	2.7V	3.2V	0V	1.2V
85	86	87	88	89	90	91	92	93	94	95	96
1.6V	3.2V	1.6V	0V	0V	0V	0V	0V	0V	0V	0V	0V
97	98	99	100								
0V	3.2V	0V	0V								

• IC502

1	2	3	4	5	6	7	8	9	10	11	12
0V	2.1V	3.2V	0V	2.3V	2V	1.6V	1.5V	1.5V	1.5V	2V	1V
13	14	15	16	17	18	19	20	21	22	23	24
0V	0V	0V	3.2V	0V	1.6V	1.6V	1.6V	1.6V	1.6V	1.6V	0V
25	26	27	28	29	30	31	32				
1.6V	1.6V	1.6V	1.6V	1.6V	1.6V	1.6V	1.6V				

• IC503

1	2	3	4	5	6	7	8	9	10	11	12
0V	0V	1.2V	3.5V	1.6V	1.5V	6.3V	6.3V	0V	0V	3.6V	3V
13	14	15	16	17	18	19	20	21	22	23	24
3.3V	3.3V	2.9V	3.5V	3.2V	3.2V	0V	6.3V	3.5V	1.6V	1.6V	1.6V
25	26	27	28								
1.6V	1.6V	1.6V	1.6V								

• IC504

1	2	3	4	5	6	7	8	9	10	11	12
3.2V	0V	0V	0V	0V	0V	3.2V	0V	0V	0V	0V	0V
13	14	15	16	17	18	19	20	21	22	23	24
3.2V	3.2V	3.2V	3.2V	3.2V	3.2V	0V	0V	0V	0V	0V	0V
25	26	27	28	29	30	31	32	33	34	35	36
3.2V	0V	0V	0V	0V	0V	0V	0V	0V	3.2V	0V	3.2V
37	38	39	40	41	42	43	44	45	46	47	48
0V	3.2V	0V	0V	0V	0V	0V	3.2V	0V	0V	0V	0V
49	50										
0V	0V										

• IC601

1	2	3	4	5	6	7	8	9	10	11	12
4.4V	4.8V	4.8V	4.7V	4.7V	5.4V	0V	4.8V	4.8V	4.8V	2.3V	2.5V
13	14	15	16	17	18	19	20	21	22	23	24
0V	2.3V	2.4V	4.8V	4.8V	4.8V	0V	4.8V	4.8V	4.8V	0.3V	0.3V
25	26	27	28	29	30	31	32	33	34	35	36
0V	0.4V	0V	0V	0V	0V	0V	4.9V	0.1V	4.8V	0V	4.9V
37	38	39	40	41	42	43	44	45	46	47	48
0V	0V	0V	4.7V	0V	0V	0.4V	4.9V	0V	4.9V	0V	0V
49	50	51	52	53	54	55	56	57	58	59	60
4.7V	0V	0V	4.8V	0V	0V	4.9V	0V	0V	0V	0V	0V
61	62	63	64	65	66	67	68	69	70	71	72
0V	4.8V	4.8V	0V	0V	0V	0V	0V	0V	0V	4.8V	0V
73	74	75	76	77	78	79	80				
0V	0.2V	0.7V	0.1V	0V	0V	0V	4.8V				

• **Q201**

E	C	B
0V	0V	13.7V

• **Q202**

E	C	B
14V	14.3V	14.3V

• **Q203**

E	C	B
0V	13.9V	0V

• **Q204**

E	C	B
0V	14.4V	14.4V

• **Q205**

E	C	B
14.4V	14.4V	13.6V

• **Q206**

E	C	B
0V	0V	3.8V

• **Q207**

E	C	B
0V	14V	0V

• **Q208**

E	C	B
0V	0V	0.6V

• **Q209**

E	C	B
0V	0V	0.6V

• **Q210**

E	C	B
0V	0V	0.6V

• **Q211**

E	C	B
0V	0V	0.6V

• **Q308**

E	C	B
12.5V	12.5V	11.6V

• **Q309**

E	C	B
0V	3.8V	11.7V

• **Q802**

E	C	B
1.4V	6.4V	6.4V

• **Q307**

E	C	B
12.5V	12.5V	11.6V

• **Q310**

E	C	B
0V	4.9V	0V

• **Q311**

E	C	B
0V	4.9V	4.9V

• **Q803**

E	C	B
0V	6.4V	4.3V

• **Q804**

E	C	B
6.5V	9.9V	7V

• **Q807**

E	C	B
0V	0V	0.6V

• **Q808**

E	C	B
5.2V	5.2V	4.6V

• **Q810**

E	C	B
10V	13V	10.6V

• **Q811**

E	C	B
11.6V	12.3V	12.3

• **Q813**

E	C	B
0V	0V	0.6V

• **Q814**

E	C	B
8.8V	9.5V	11.8V

• **Q815**

E	C	B
8.2V	8.9V	8.9V

• **Q818**

E	C	B
8.3V	9V	9V

• **Q819**

E	C	B
0V	0V	4.3V

• **Q820**

E	C	B
8.7V	9V	8V

• **Q501**

E	C	B
1.9V	2.85V	2.2V

• **Q502**

E	C	B
3.3V	3.3V	2.5V

• **Q503**

E	C	B
3.3V	0V	4.4V

• **Q504**

E	C	B
0V	0V	0V

• **Q505**

E	C	B
0V	0V	0V

• **Q601**

E	C	B
0V	4.8V	0V

• **Q602**

E	C	B
0V	0V	0.6V

• **Q603**

E	C	B
0V	0.2V	4.7V

• **Q604**

E	C	B
3.9V	4.5V	4.5V

• **Q605**

E	C	B
0V	0V	4.5V

• **Q606**

E	C	B
5.5V	5.5V	0V

• **Q607**

E	C	B
0	0	0.6V

• **Q801**

E	C	B
0.2V	10V	5V

□ BLOCK DIAGRAM

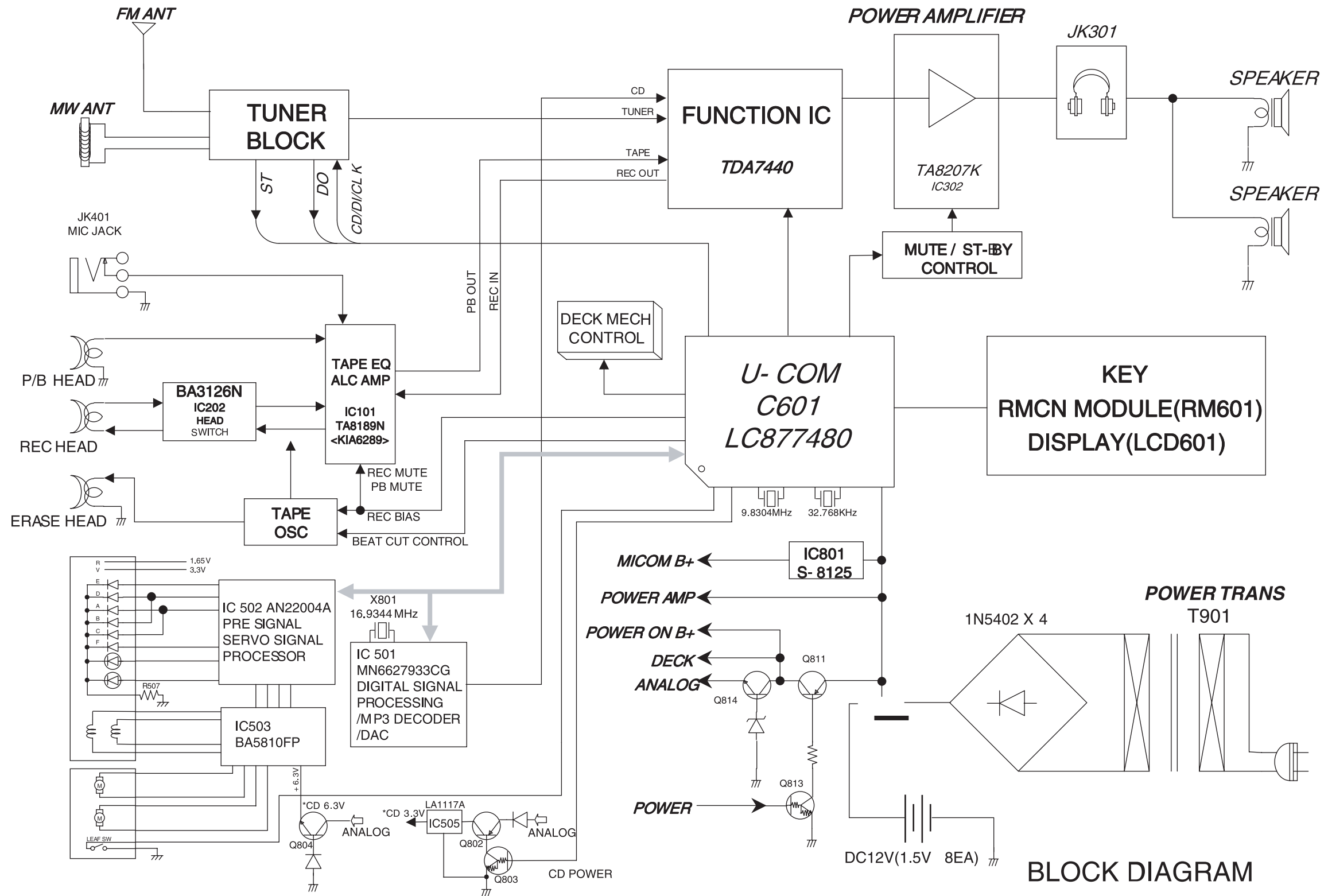

BLOCK DIAGRAM
MODEL : LPC- LM340

SCHEMATIC DIAGRAMS

1. MAIN SCHEMATIC DIAGRAM (POWER/EQ/AMP)

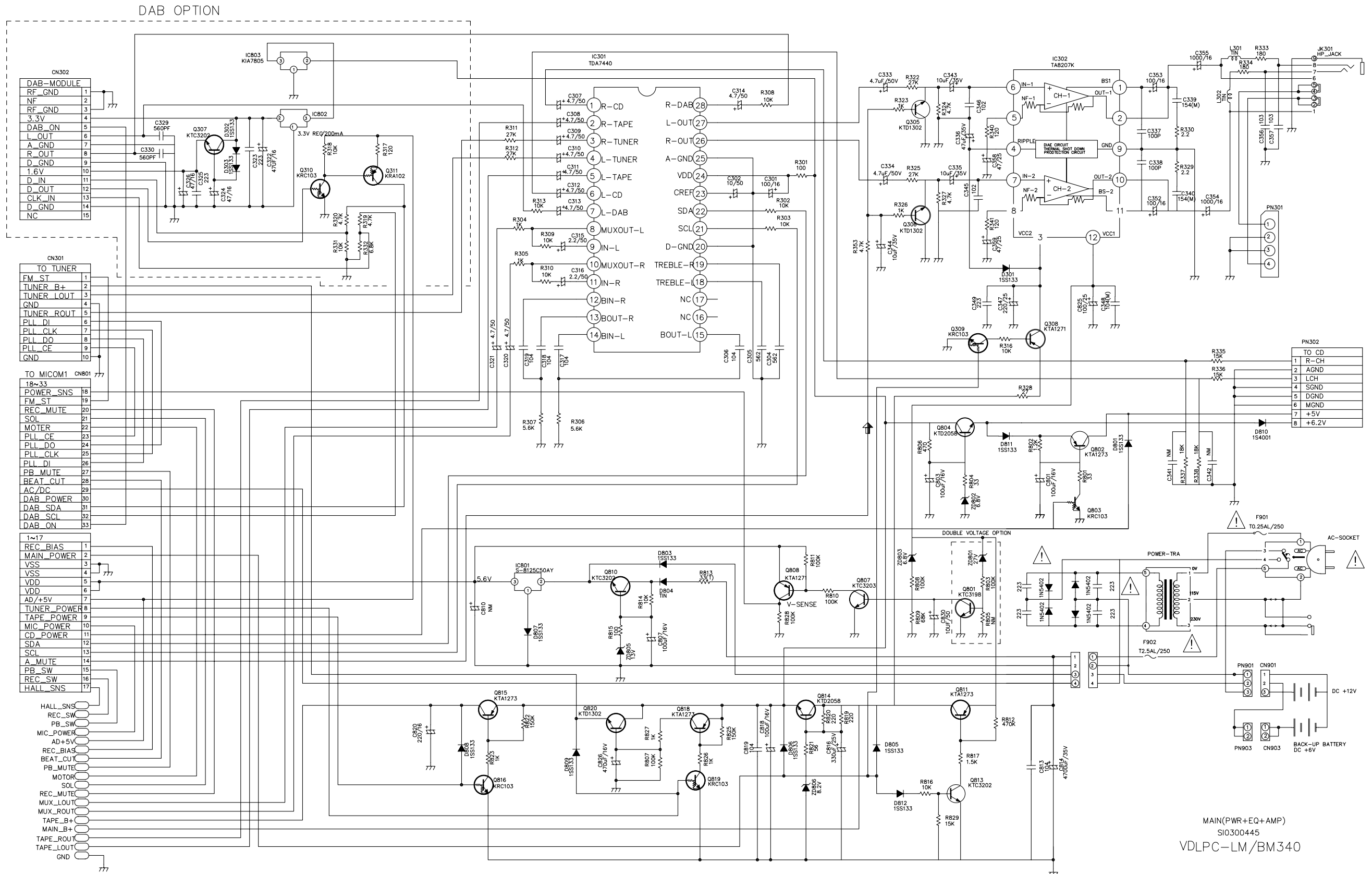

2. FRONT/MICOM SCHEMATIC DIAGRAM

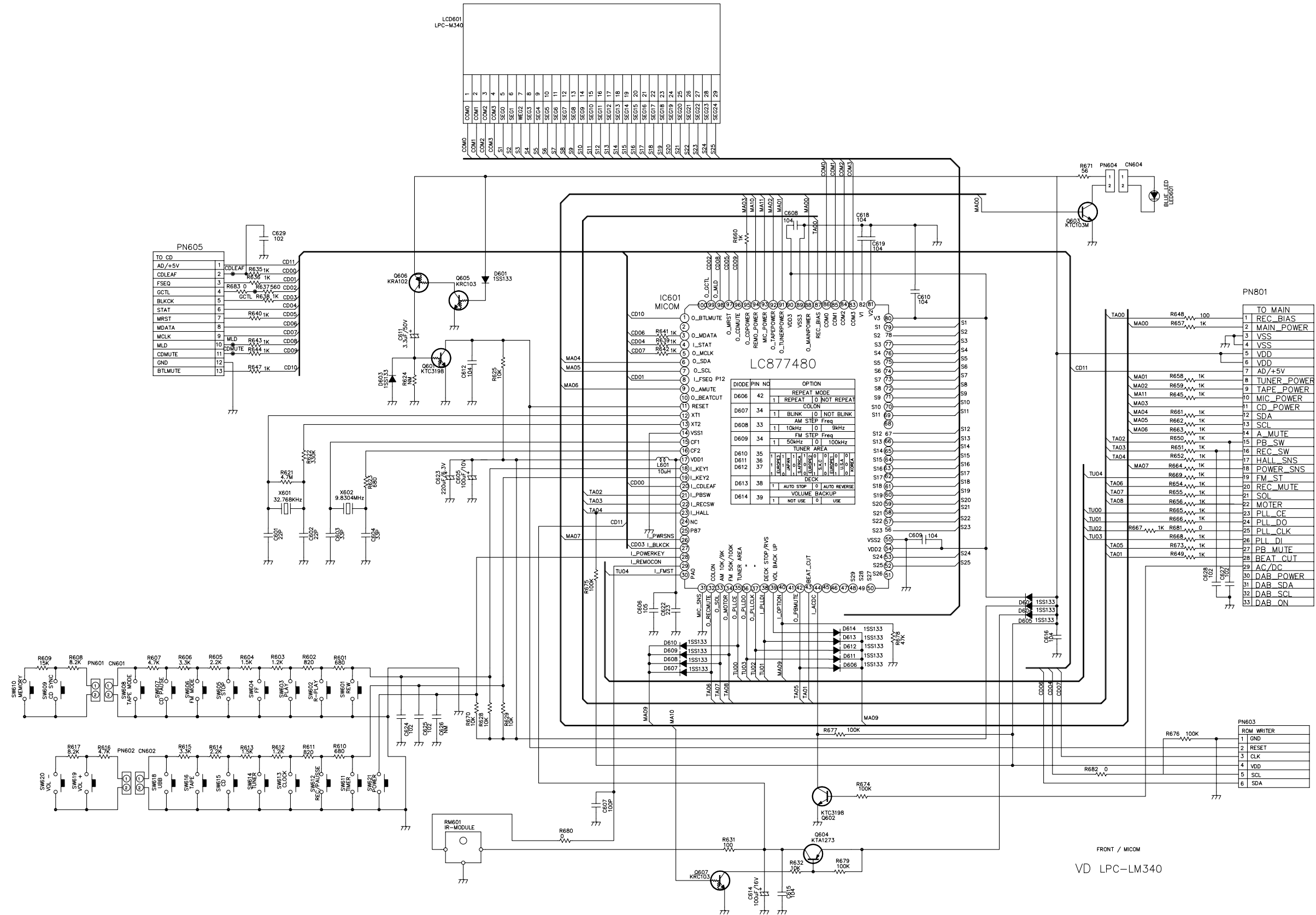

3. DECK SCHEMATIC DIAGRAM

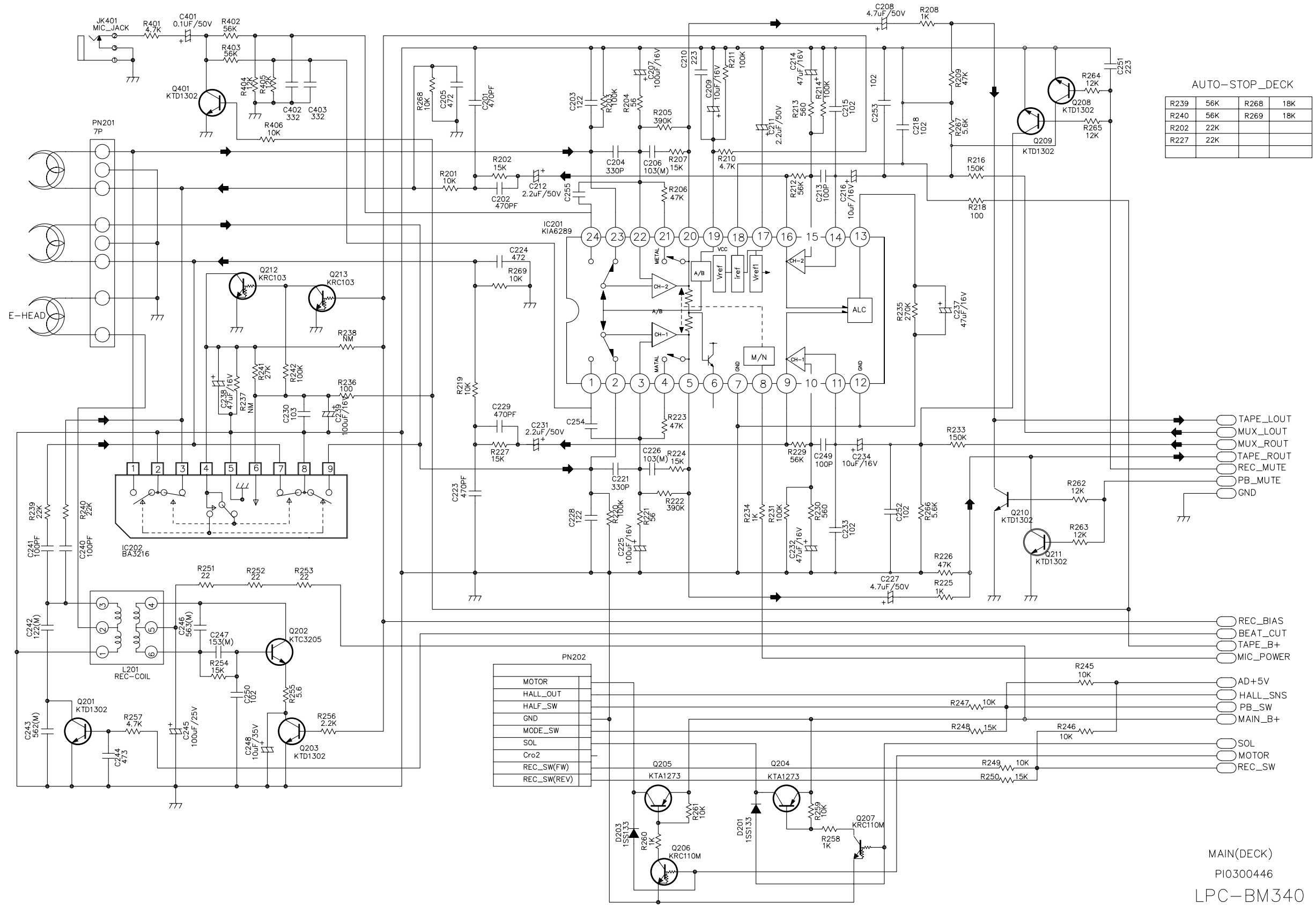

4. CDP SCHEMATIC DIAGRAM

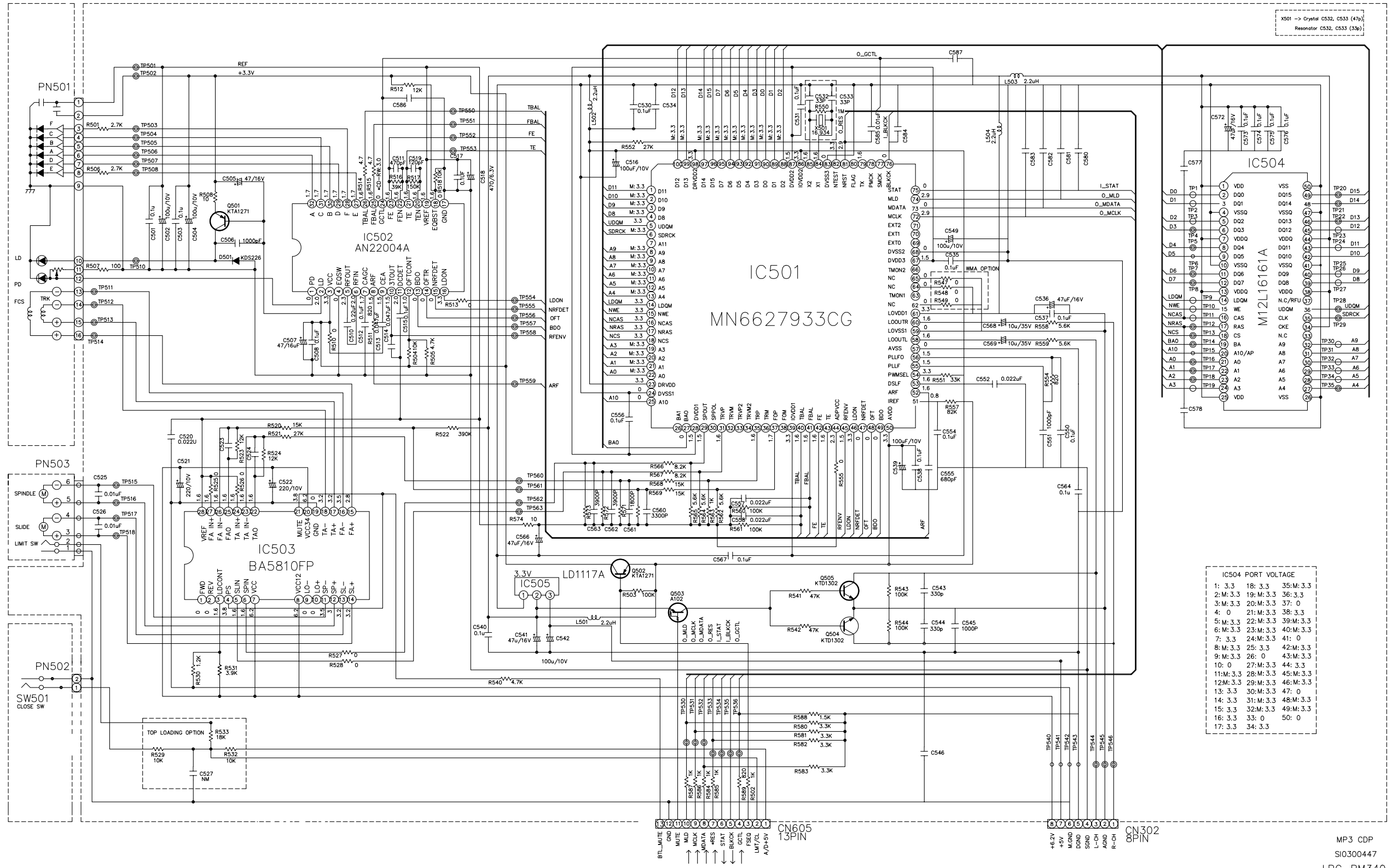

PRINTED CIRCUIT DIAGRAM

1. MAIN P.C. DIAGRAM (SOLDER SIDE)

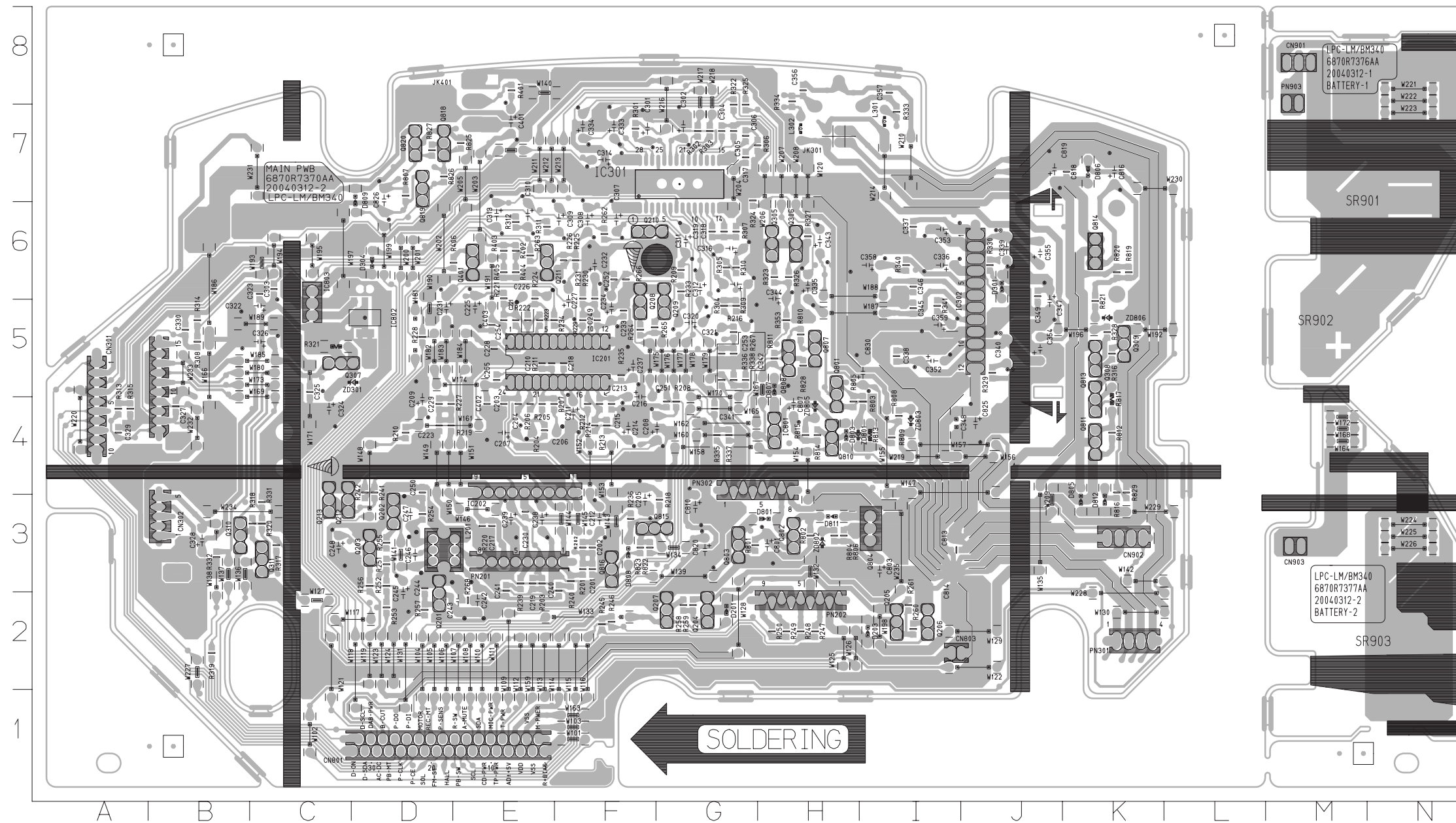

C201	F3	C402	E4	R249	H2	R329	J5
C202	F3	C403	E5	R250	H2	R330	J6
C203	E4	C813	I3	R251	D3	R331	C3
C204	E4	C819	K7	R252	D3	R332	B3
C210	E5	IC301	G7	R253	D2	R333	I7
C213	F4	IC802	D5	R254	D3	R334	H8
C215	F4	R201	F3	R255	D3	R335	G4
C217	E3	R202	F3	R256	D3	R336	G5
C218	F5	R203	E3	R257	D2	R337	G4
C219	E3	R204	E4	R258	G2	R338	G5
C221	E5	R205	E4	R259	G2	R340	I6
C223	D4	R206	E4	R260	I2	R341	I5
C228	E5	R207	E4	R261	I2	R353	H5
C229	D4	R208	G4	R262	F6	R401	E8
C230	E3	R209	G6	R263	E6	R402	E6
C233	F5	R210	D4	R264	F5	R403	E6
C240	F3	R211	E5	R265	F5	R404	E6
C241	E3	R212	F4	R266	F6	R405	E6
C244	D3	R213	F4	R267	G5	R406	E6
C249	F5	R214	F4	R268	E2	R801	G3
C250	D4	R216	G5	R301	F7	R802	H3
C251	G4	R218	G3	R302	G7	R803	I4
C252	F6	R219	D4	R303	G7	R804	H3
C253	G5	R220	E3	R304	G5	R805	H4
C254	E5	R221	E6	R305	G6	R806	H3
C255	E5	R222	E5	R306	H7	R807	D7
C303	G6	R223	E5	R307	G6	R808	I4
C304	G7	R224	E6	R308	B5	R809	I4
C305	G7	R225	F6	R309	G5	R810	H5
C306	G7	R226	F6	R310	G6	R811	H5
C317	G7	R227	D4	R311	E6	R812	K4
C318	G6	R228	D5	R312	E6	R814	H4
C319	G6	R229	F5	R313	A4	R815	H4
C323	C6	R230	F6	R314	B5	R816	K4
C325	C5	R231	F6	R315	A4	R819	K6
C327	B4	R233	G6	R316	K5	R820	K6
C329	A4	R234	E5	R317	C3	R821	K5
C330	B5	R235	F5	R318	C3	R822	F3
C337	I6	R236	F3	R319	B2	R823	F3
C338	I5	R239	E3	R320	C3	R825	E7
C341	G4	R240	F3	R322	G7	R826	D7
C342	G5	R241	D4	R323	H6	R827	D7
C345	I5	R242	D4	R324	G7	R828	H5
C346	I6	R245	F2	R325	G7	R829	K4
C349	J6	R246	F2	R326	H6		
C356	H8	R247	H2	R327	H6		
C357	I8	R248	H2	R328	K5		

1. MAIN P.C. DIAGRAM (COMPONENT SIDE)

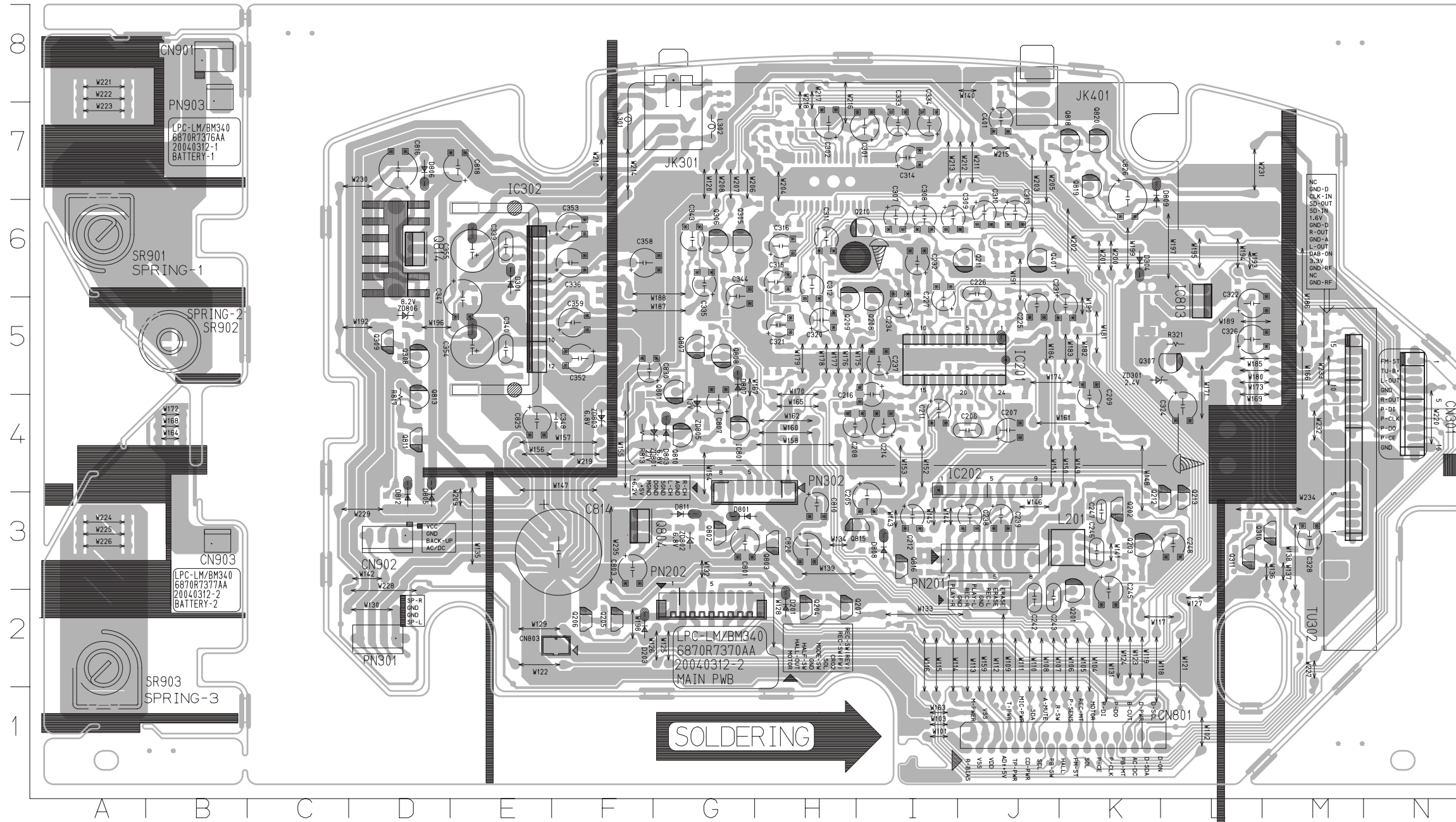

C205	I3	C347	E5	PN202	G2
C206	J4	C348	F4	PN301	D2
C207	J4	C352	F5	PN302	H4
C208	H4	C353	F6	PN903	B8
C209	K4	C354	E5	Q201	K2
C211	I4	C355	E6	Q202	K3
C212	I3	C358	F6	Q203	K3
C214	I4	C359	F5	Q204	H2
C216	I4	C401	J7	Q205	F2
C225	J5	C801	G3	Q206	F2
C226	J6	C803	F3	Q207	H2
C227	I5	C807	G4	Q208	I5
C231	K5	C810	H3	Q209	H5
C232	I6	C814	F3	Q210	I6
C234	I5	C816	E7	Q211	J6
C237	I5	C818	D7	Q212	L3
C238	J3	C820	H3	Q213	L3
C239	J3	C825	E4	Q305	G6
C242	J2	C826	K7	Q306	G6
C243	J2	C830	F5	Q307	L5
C245	K2	CN301	N5	Q308	D5
C246	K3	CN801	J1	Q309	D5
C247	K3	CN803	F2	Q310	M3
C248	L3	CN901	B8	Q311	L3
C301	I7	CN902	D3	Q401	J6
C302	H7	CN903	B3	Q801	G5
C307	I6	D201	H2	Q802	G3
C308	I6	D203	F2	Q803	H3
C309	I6	D301	E6	Q804	F3
C310	J6	D304	K6	Q807	G5
C311	H6	D801	G3	Q808	G5
C312	H6	D803	G4	Q810	G4
C313	J6	D805	D3	Q811	D4
C314	I7	D806	D7	Q813	D4
C315	H6	D807	G5	Q814	D6
C316	H6	D808	I3	Q815	I3
C320	H5	D809	K7	Q816	I3
C321	H5	D811	G3	Q818	K7
C322	L5	D812	D3	Q819	K7
C324	L4	IC201	J5	Q820	K7
C326	L5	IC202	I4	R321	L5
C328	M3	IC302	E6	R813	F4
C333	I7	IC801	G4	R817	D4
C334	I7	IC803	L5	TU302	M3
C335	G6	JK301	G8	ZD301	K5
C336	F6	JK401	J8	ZD801	G4
C339	E6	L201	K3	ZD802	G3
C340	E5	L301	F7	ZD803	F4
C343	G6	L302	G7	ZD805	G4
C344	G6	PN201	I3	ZD806	D5

2. FRONT P.C. DIAGRAM (SOLDER SIDE)

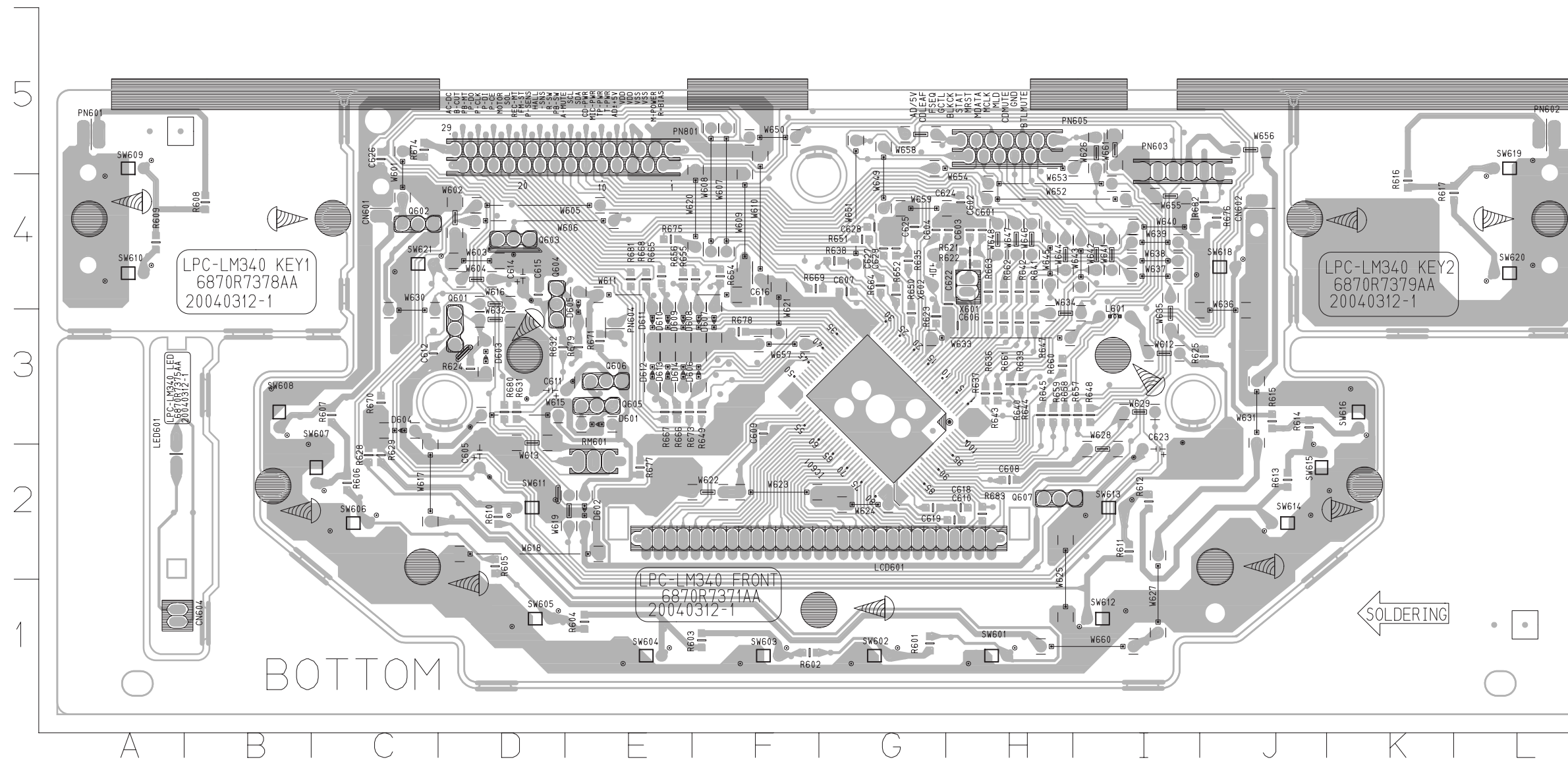

C601	H4	R629	C2
C602	H4	R631	D3
C603	H4	R632	D3
C604	G4	R635	G4
C606	H3	R636	H3
C607	G4	R637	H3
C608	H2	R638	G4
C609	F3	R639	H3
C610	H2	R640	H3
C612	C3	R641	H4
C615	D4	R642	H4
C616	F4	R643	H3
C618	H2	R644	H3
C619	G2	R645	H3
C622	H4	R647	H3
C624	H4	R648	I3
C625	G4	R649	F3
C626	C5	R650	G3
C627	G4	R651	G4
C628	G4	R652	G4
C629	G4	R654	F4
CDLEAF	G5	R655	F4
CDMUTE	H5	R656	E4
GCTL	H4	R657	I3
IC601	G3	R658	H3
MLD	H4	R659	H3
R601	G1	R660	H3
R602	F1	R661	H3
R603	F1	R662	H4
R604	E1	R663	H4
R605	D2	R664	G4
R606	C2	R665	E4
R607	C3	R666	E3
R608	B4	R667	E3
R609	A4	R668	E4
R610	D2	R669	F4
R611	I2	R670	C3
R612	I2	R671	E3
R613	J2	R673	E3
R614	J3	R674	C5
R615	J3	R675	E4
R616	K4	R676	J4
R617	L4	R677	E2
R621	H4	R678	F3
R622	H4	R679	E3
R623	G3	R680	D3
R624	D3	R681	E4
R625	J3	R682	J4
R628	C2	R683	H2

2. FRONT P.C. DIAGRAM (COMPONENT SIDE)

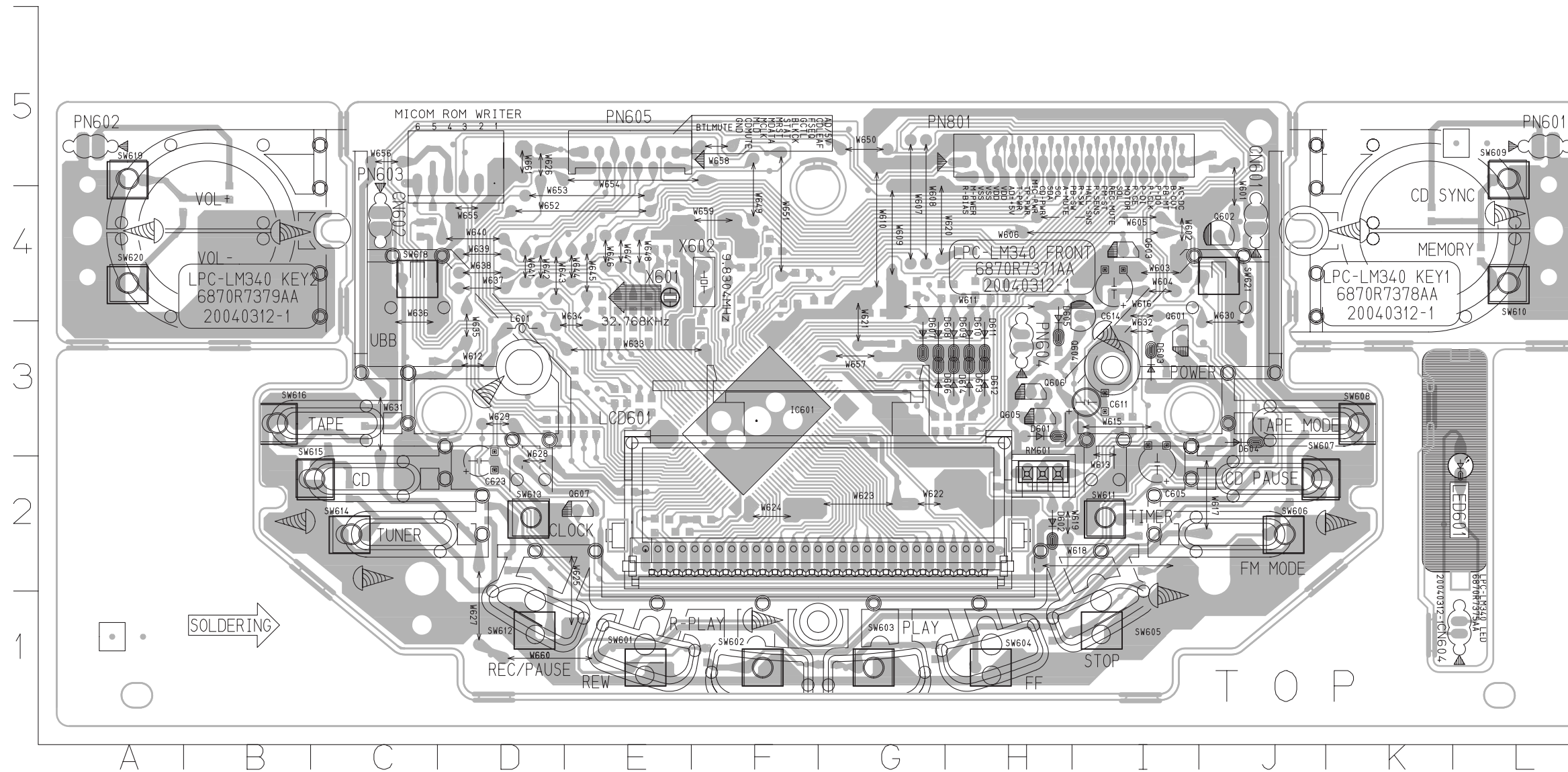

C605	I2
C611	I3
C614	I4
C623	D2
CN601	J4
CN602	C4
CN604	L1
D601	H3
D602	H2
D603	I3
D604	J3
D605	H4
D606	G3
D607	G3
D608	G3
D609	H3
D610	H3
D611	H3
D612	H3
D613	H3
D614	H3
L601	D3
LCD601	E2
LED601	L2
PN601	L5
PN602	A5
PN603	D5
PN604	H3
PN605	E5
PN801	H5
Q601	I3
Q602	J4
Q603	I4
Q604	I4
Q605	H3
Q606	H3
Q607	E2
RM601	H2
SW601	E1
SW602	F1
SW603	G1
SW604	H1
SW605	I1
SW606	J2
SW607	J2
SW608	K3
SW609	L5
SW610	L4
SW611	I2
SW612	D1
SW613	D2
SW614	C2
SW615	C2
SW616	B3
SW618	C4
SW619	A5
SW620	A4
SW621	J4
X601	E4
X602	F4

3. BATTERY/POWER P.C. DIAGRAM

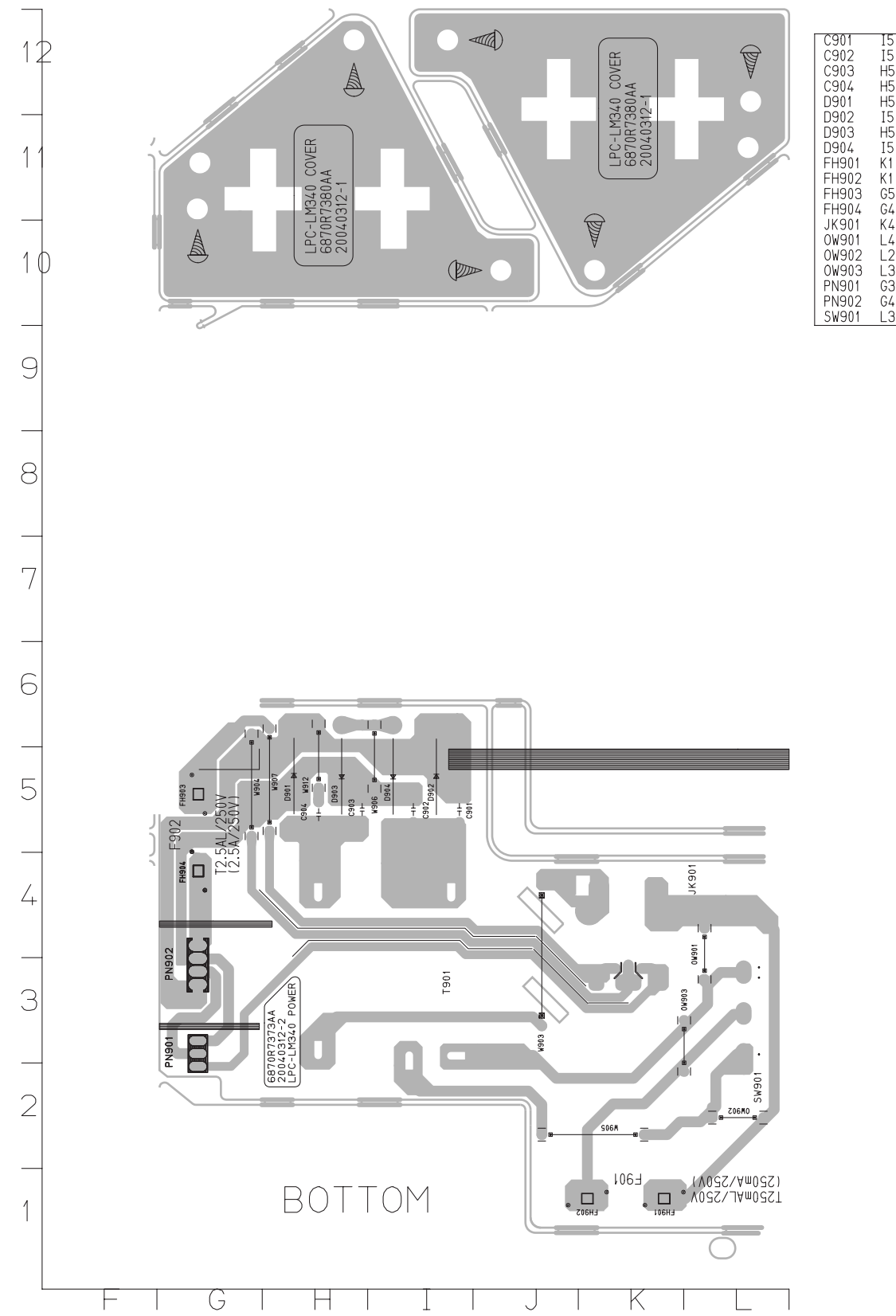

4. CD-MP3 P.C. DIAGRAM

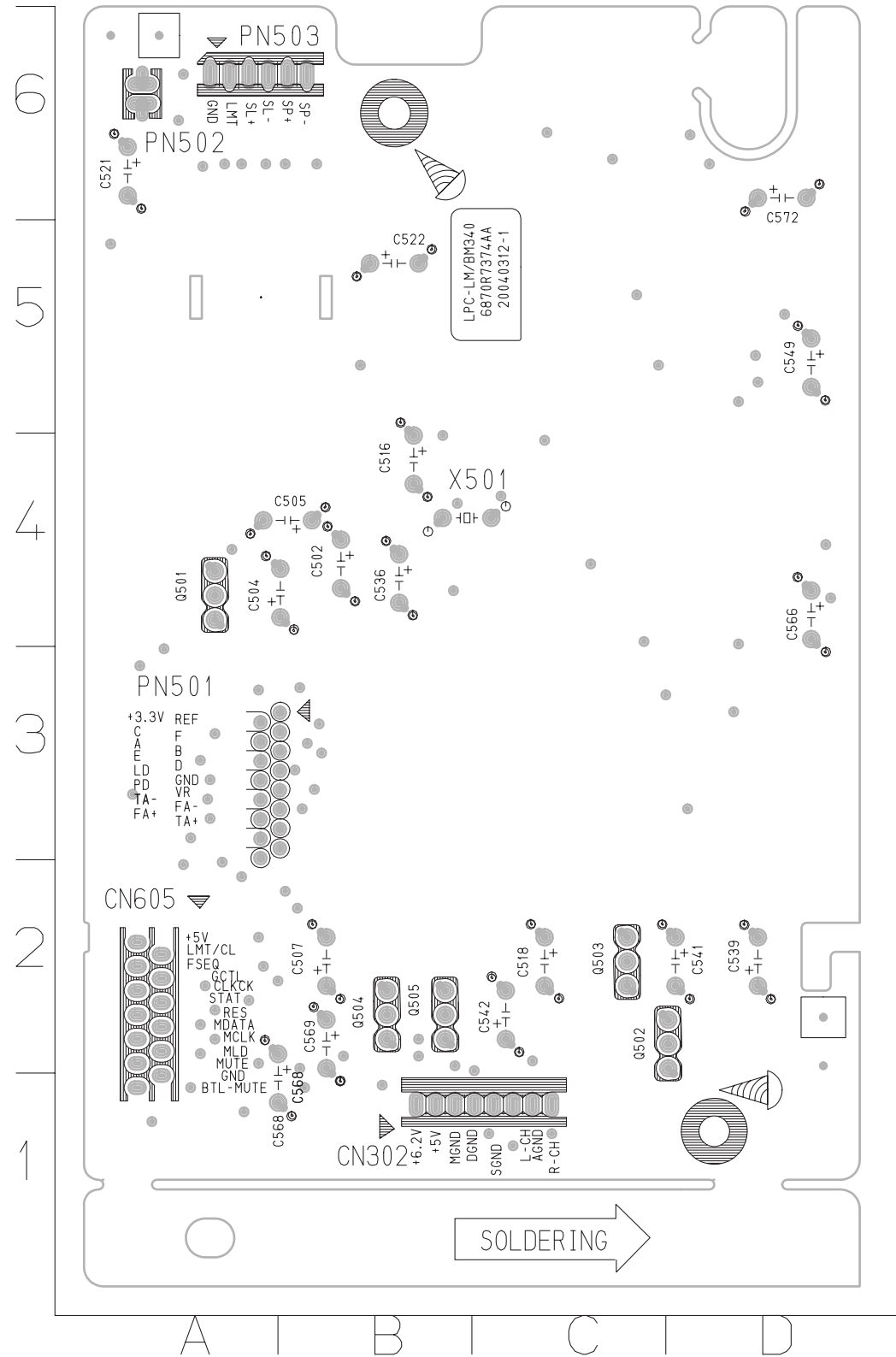

C501	A3	C546	C2	L501	C1	R533	A6	TP10	D5	TP515	B6
C502	B4	C549	D5	L502	B4	R540	A1	TP11	C6	TP516	A6
C503	B4	C550	C3	L503	C6	R541	B2	TP12	C6	TP517	A6
C504	B4	C551	C3	L504	B4	R542	B2	TP13	D6	TP518	A5
C505	B4	C552	D3	PN501	B3	R543	B2	TP14	D6	TP530	A1
C506	A4	C554	D3	PN502	A6	R544	B2	TP15	D6	TP531	A1
C507	B2	C555	D3	PN503	A6	R547	C3	TP16	D5	TP532	A3
C508	B3	C556	D5	Q501	A4	R548	C3	TP17	D5	TP533	A2
C510	C3	C557	D4	Q502	D2	R549	C3	TP18	D5	TP534	C4
C511	C2	C558	D4	Q503	C2	R550	B4	TP2	C6	TP535	A2
C512	C3	C560	D4	Q504	B2	R551	D3	TP20	C5	TP536	B2
C513	C3	C561	D4	Q505	B2	R552	C4	TP21	C5	TP540	A5
C514	C3	C562	D4	R501	B3	R554	C3	TP22	C5	TP541	C2
C515	C3	C563	D5	R502	A2	R555	D4	TP23	C5	TP542	C1
C516	B4	C564	C3	R503	D2	R557	D4	TP24	C5	TP543	C1
C517	C2	C566	D4	R504	B3	R558	B1	TP25	C5	TP544	B1
C518	C2	C567	D4	R505	B3	R559	B2	TP26	C5	TP545	B2
C519	C2	C568	B1	R506	C2	R560	D4	TP27	C5	TP546	B1
C520	B5	C569	B2	R507	B3	R561	D4	TP28	C5	TP550	D4
C521	A6	C572	D6	R508	A4	R562	D4	TP29	C5	TP551	C3
C522	B5	C573	C6	R510	B3	R563	D4	TP3	C6	TP552	C3
C523	B5	C574	C6	R511	C3	R564	D4	TP30	C5	TP553	C2
C524	B5	C575	D5	R512	C2	R565	D5	TP31	C5	TP554	D4
C525	B6	C576	C6	R513	C3	R566	D5	TP32	C5	TP555	C3
C526	A6	C577	C6	R514	C2	R567	D4	TP33	C5	TP556	C3
C527	A4	C578	C6	R515	C3	R568	D4	TP34	D5	TP557	D4
C530	C4	C580	C4	R516	C2	R569	D4	TP35	D5	TP558	C3
C531	C4	C581	C4	R517	C2	R571	D4	TP4	C6	TP559	C3
C532	C4	C582	C4	R518	C2	R572	D4	TP5	C5	TP560	B5
C533	B4	C583	C4	R520	B5	R573	D5	TP501	B5	TP561	B5
C534	C5	C584	C4	R521	B5	R574	D4	TP502	B2	TP562	A4
C535	C4	C585	C4	R522	B5	R580	A2	TP503	B2	TP563	A4
C536	B4	C586	C2	R523	B5	R581	A1	TP504	B2	TP6	C5
C537	C4	C587	C2	R524	B5	R582	A2	TP505	B2	TP7	C5
C538	D3	CN302	B1	R525	B5	R583	A2	TP506	B2	TP8	C5
C539	D2	CN605	A2	R526	B5	R584	A2	TP507	B2	TP9	D5
C540	C1	D501	A3	R527	A5	R585	A2	TP508	C2	X501	B4
C541	D2	IC501	C4	R528	A5	R586	A2	TP510	A3		
C542	C2	IC502	C3	R529	A4	R587	A2	TP511	B6		
C543	B2	IC503	A5	R530	A5	R588	A2	TP512	B6		
C544	B2	IC504	C5	R531	A5	R589	A2	TP513	B6		
C545	B4	IC505	C2	R532	A2	TP1	C6	TP514	A4		

WIRING DIAGRAM

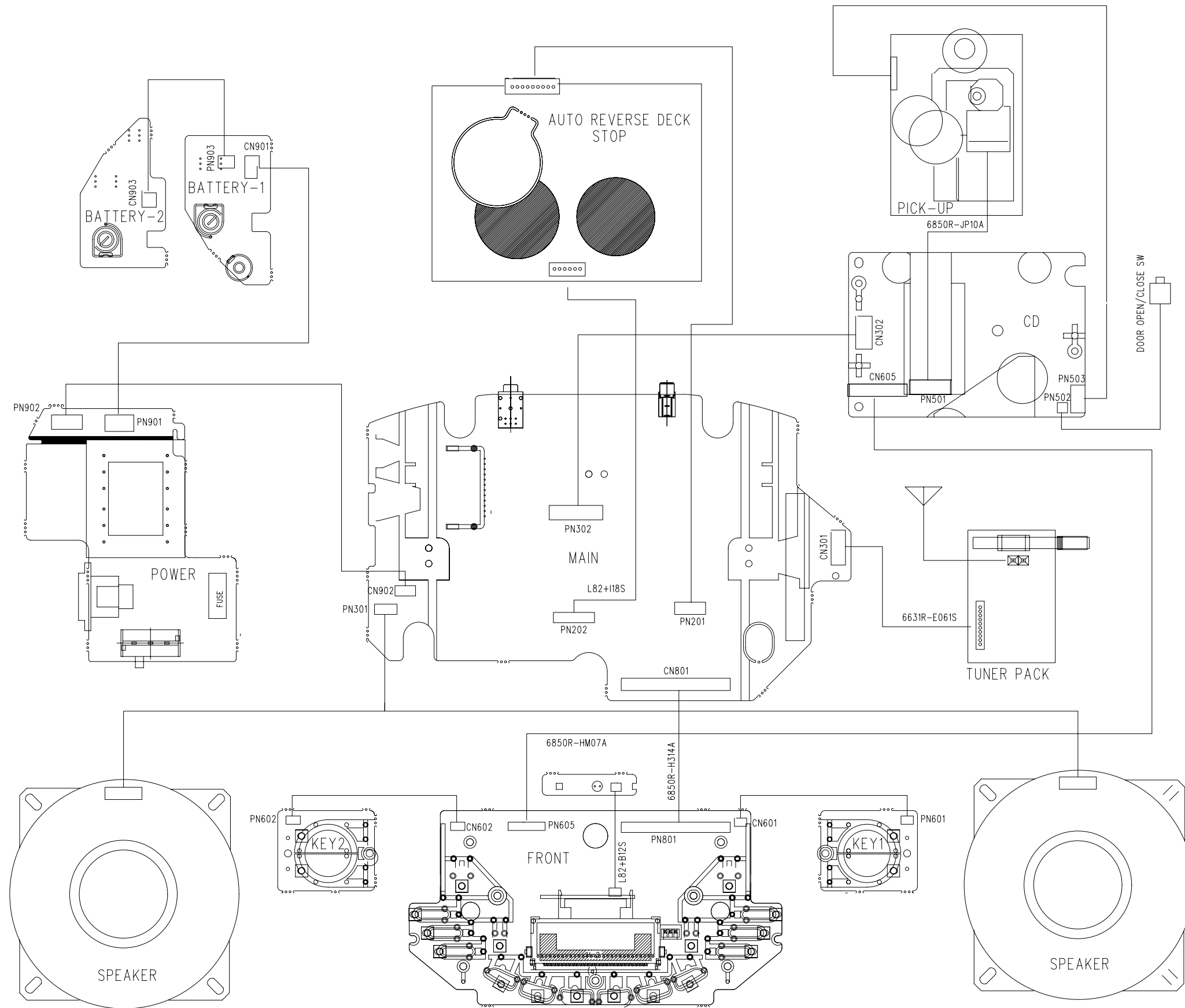

SECTION 3. EXPLODED VIEWS

NOTE) Refer to "SECTION 4 REPLACEMENT PARTS LIST" in order to look for the part number of each part.

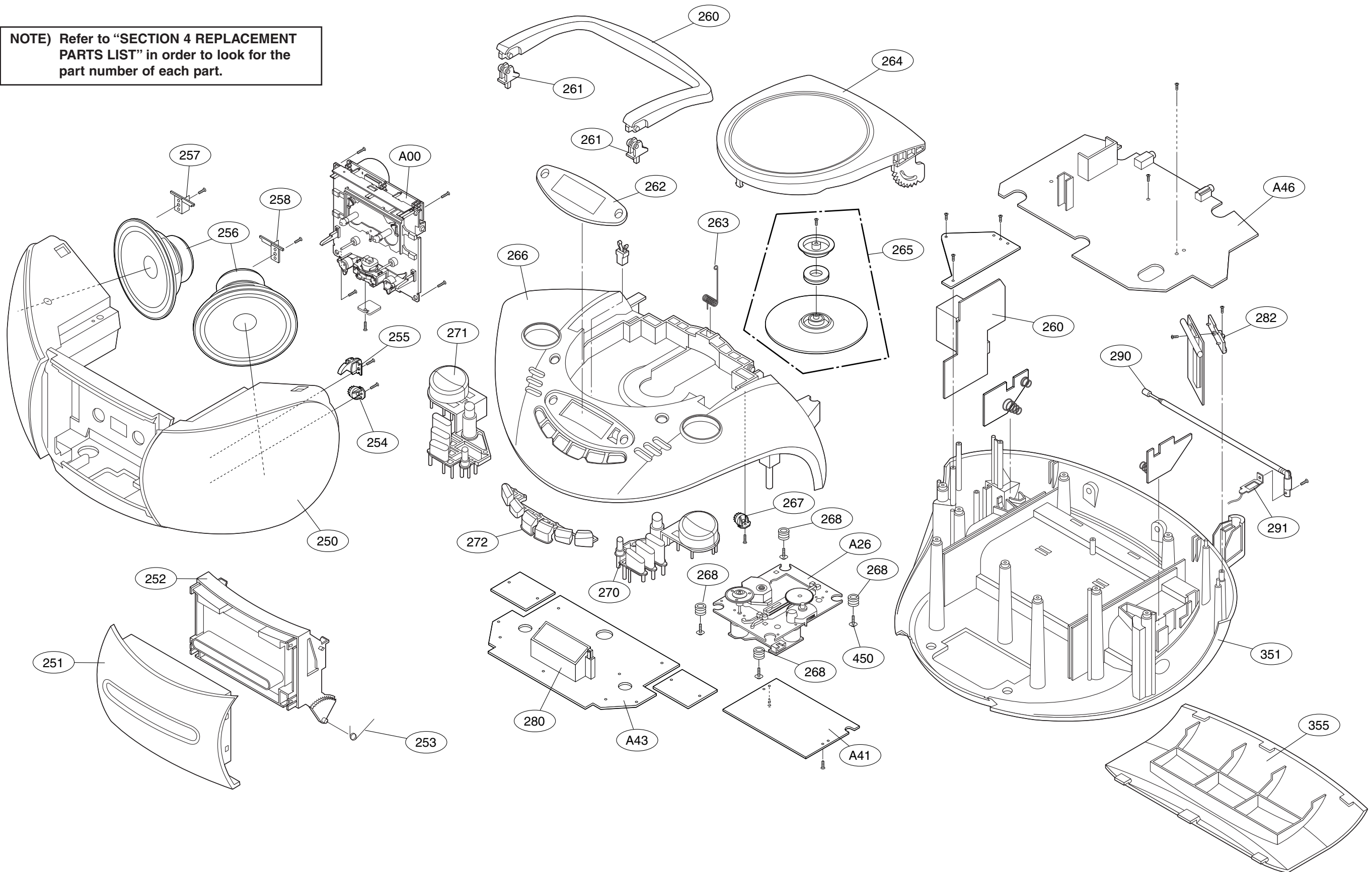

MEMO

MEMO