

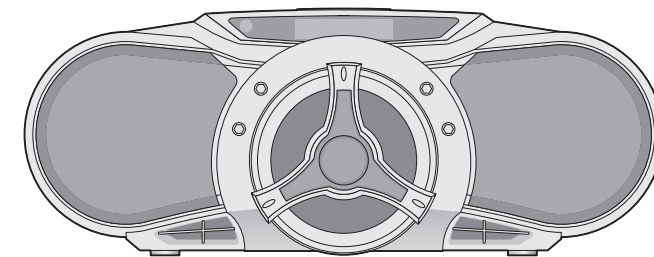

SERVICE MANUAL MODEL: LPC-LM440A/X LPC-LM445A/X



# MP3/CD LOGIC DECK CASSETTE RECORDER **SERVICE MANUAL**



**MODEL: LPC-LM440A/X  
LPC-LM445A/X**

LG Electronics Inc.

# [CONTENTS]

## ○ SECTION 1.GENERAL

- SERVICING PRECAUTIONS ..... 1-2
- ESD PRECAUTIONS ..... 1-4
- SPECIFICATION .....1-5
- IDENTIFICATIONS OFCONTROLS ..... 1-6

## ○ SECTION 2.ELECTRICAL SECTION

- ADJUSTMENT ..... 2-1
- TROUBLESHOOTING GUIDE ..... 2-2
- INTERNAL BLOCK DIAGRAM OF ICs ..... 2-17
- IC/TR VOLTAGE & PIN DESCRIPTION ..... 2-23
- BLOCK DIAGRAM ..... 2-27
- SCHEMATIC DIAGRAMS ..... 2-29
- WIRING DIAGRAM ..... 2-41
- PRINTED CIRCUIT BOARD DIAGRAM ..... 2-43

## ○ SECTION 3. EXPLODED VIEWS ..... 3-1

## ○ SECTION 4. REPLACEMENT PARTS ..... 4-1

# SECTION 1. GENERAL

## ☐ SERVICING PRECAUTIONS

### NOTES REGARDING HANDLING OF THE PICK-UP

#### 1. Notes for transport and storage

- 1) The pick-up should always be left in its conductive bag until immediately prior to use.
- 2) The pick-up should never be subjected to external pressure or impact.

Storage in conductive bag

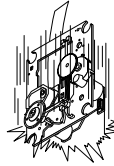
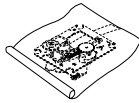

Drop impact

#### 2. Repair notes

- 1) The pick-up incorporates a strong magnet, and so should never be brought close to magnetic materials.
- 2) The pick-up should always be handled correctly and carefully, taking care to avoid external pressure and impact. If it is subjected to strong pressure or impact, the result may be an operational malfunction and/or damage to the printed-circuit board.
- 3) Each and every pick-up is already individually adjusted to a high degree of precision, and for that reason the adjustment point and installation screws should absolutely never be touched.
- 4) Laser beams may damage the eyes!  
Absolutely never permit laser beams to enter the eyes!  
Also NEVER switch ON the power to the laser output part (lens, etc.) of the pick-up if it is damaged.

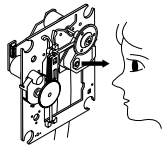

NEVER look directly at the laser beam, and don't let contact fingers or other exposed skin.

#### 5) Cleaning the lens surface

If there is dust on the lens surface, the dust should be cleaned away by using an air bush (such as used for camera lens). The lens is held by a delicate spring. When cleaning the lens surface, therefore, a cotton swab should be used, taking care not to distort this.

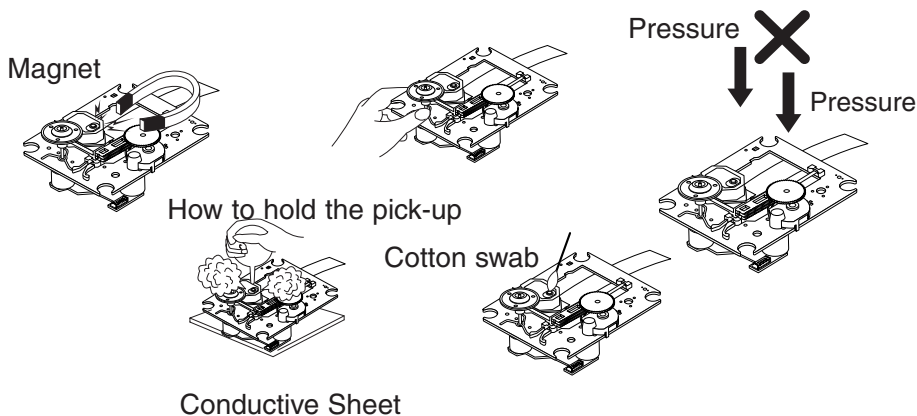

#### 6) Never attempt to disassemble the pick-up.

Spring by excess pressure. If the lens is extremely dirty, apply isopropyl alcohol to the cotton swab. (Do not use any other liquid cleaners, because they will damage the lens.) Take care not to use too much of this alcohol on the swab, and do not allow the alcohol to get inside the pick-up.

# NOTES REGARDING COMPACT DISC PLAYER REPAIRS

## 1. Preparations

- 1) Compact disc players incorporate a great many ICs as well as the pick-up (laser diode). These components are sensitive to, and easily affected by, static electricity. If such static electricity is high voltage, components can be damaged, and for that reason components should be handled with care.
- 2) The pick-up is composed of many optical components and other high-precision components. Care must be taken, therefore, to avoid repair or storage where the temperature or humidity is high, where strong magnetism is present, or where there is excessive dust.

## 2. Notes for repair

- 1) Before replacing a component part, first disconnect the power supply lead wire from the unit
- 2) All equipment, measuring instruments and tools must be grounded.
- 3) The workbench should be covered with a conductive sheet and grounded.  
When removing the laser pick-up from its conductive bag, do not place the pick-up on the bag. (This is because there is the possibility of damage by static electricity.)
- 4) To prevent AC leakage, the metal part of the soldering iron should be grounded.
- 5) Workers should be grounded by an armband (1M  $\Omega$ )
- 6) Care should be taken not to permit the laser pick-up to come in contact with clothing, in order to prevent static electricity changes in the clothing to escape from the armband.
- 7) The laser beam from the pick-up should NEVER be directly facing the eyes or bare skin.

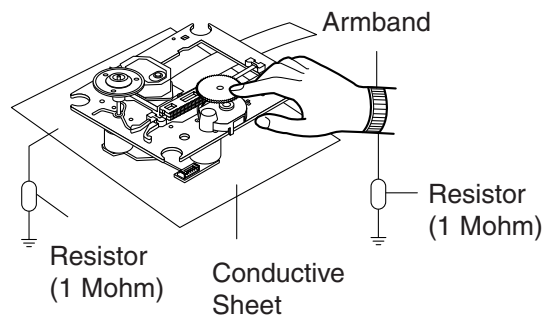

## □ ESD PRECAUTIONS

### Electrostatically Sensitive Devices (ESD)



Some semiconductor (solid state) devices can be damaged easily by static electricity. Such components commonly are called Electrostatically Sensitive Devices (ESD). Examples of typical ESD devices are integrated circuits and some field-effect transistors and semiconductor chip components. The following techniques should be used to help reduce the incidence of component damage caused by static electricity.

1. Immediately before handling any semiconductor component or semiconductor-equipped assembly, drain off any electrostatic charge on your body by touching a known earth ground. Alternatively, obtain and wear a commercially available discharging wrist strap device, which should be removed for potential shock reasons prior to applying power to the unit under test.
2. After removing an electrical assembly equipped with ESD devices, place the assembly on a conductive surface such as aluminum foil, to prevent electrostatic charge buildup or exposure of the assembly.
3. Use only a grounded-tip soldering iron to solder or unsolder ESD devices.
4. Use only an anti-static solder removal device. Some solder removal devices not classified as "anti-static" can generate electrical charges sufficient to damage ESD devices.
5. Do not use freon-propelled chemicals. These can generate electrical charges sufficient to damage ESD devices.
6. Do not remove a replacement ESD device from its protective package until immediately before you are ready to install it. (Most replacement ESD devices are packaged with leads electrically shorted together by conductive foam, aluminum foil or comparable conductive materials).
7. Immediately before removing the protective material from the leads of a replacement ESD device, touch the protective material to the chassis or circuit assembly into which the device will be installed.

**CAUTION : BE SURE NO POWER IS APPLIED TO THE CHASSIS OR CIRCUIT, AND OBSERVE ALL OTHER SAFETY PRECAUTIONS.**

8. Minimize bodily motions when handling unpackaged replacement ESD devices. (Otherwise harmless motion such as the brushing together of your clothes fabric or the lifting of your foot from a carpeted floor can generate static electricity sufficient to damage an ESD device).

### CAUTION. GRAPHIC SYMBOLS

	THE LIGHTNING FLASH WITH APROWHEAD SYMBOL. WITHIN AN EQUILATERAL TRIANGLE, IS INTENDED TO ALERT THE SERVICE PERSONNEL TO THE PRESENCE OF UNINSULATED "DANGEROUS VOLTAGE" THAT MAY BE OF SUFFICIENT MAGNITUDE TO CONSTITUTE A RISK OF ELECTRIC SHOCK.
	THE EXCLAMATION POINT WITHIN AN EQUILATERAL TRIANGLE IS INTENDED TO ALERT THE SERVICE PERSONNEL TO THE PRESENCE OF IMPORTANT SAFETY INFORMATION IN SERVICE LITERATURE.

## □ SPECIFICATIONS

SECTION		MODEL	LPC-LM440A LPC-LM445A
[General]		Power supply	Refer to the back panel of the unit.
		Power consumption	40W
		Mass	5.1kg
		External dimensions (W x H x D)	456 x 178 x 338 mm
		Output Power	5W X 2 , 10W
		Speakers	3.2Ω X 3
		Battery Operation	DC 12V, 8 "D"(R20) batteries (not supplied)
[CD]		Frequency response	100 - 18000 Hz
		Signal-to-noise ratio	65 dB
		T.H.D	0.5 %
[Tuner]	FM	Tuning Range	87.5 -108 MHz, 65 -74 MHz or 87.5 -108 MHz
		Intermediate Frequency	10.7 MHz
		Antenna	Telescopic antenna
	AM (MW)	Tuning Range	522 - 1620 kHz or 520 - 1720kHz
		Intermediate Frequency	450 kHz
		Antenna	Ferrite bar antenna
[TAPE]		Recording System	4 Tracks 2 channel stereo
		Frequency Response	125 - 8000Hz
		Signal to Noise Ratio	40/45dB (REC/PLAY)

Designs and specifications are subject to change without notice.

# IDENTIFICATIONS OF CONTROLS

## Front Front

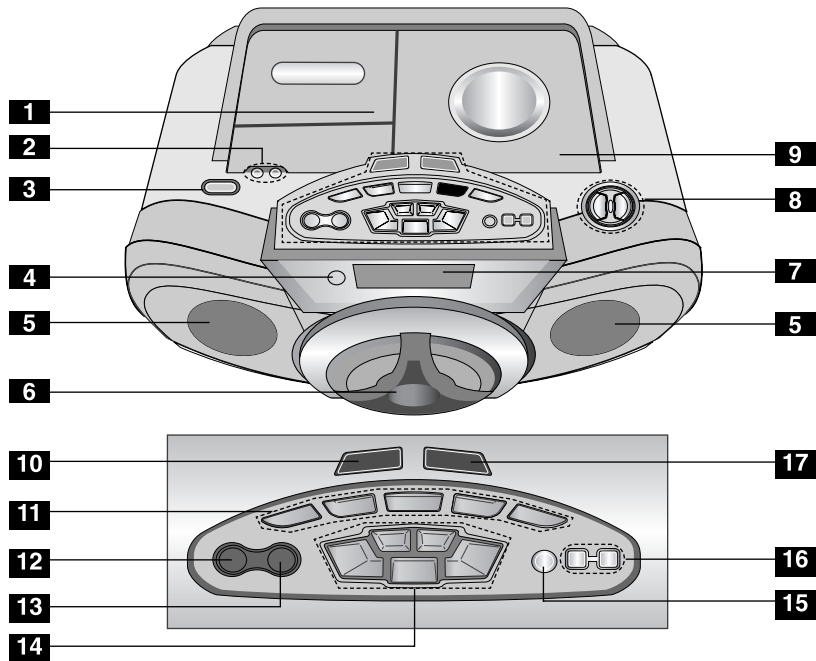

- |  |  |
|--|--|
| <ul style="list-style-type: none"> <li><b>1</b> TAPE DOOR (▲ PUSH EJECT)</li> <li><b>2</b> • CLOCK button</li> <li>• ⌚ TIMER button</li> <li><b>3</b> POWER (⏻ STANDBY/ON) button</li> <li><b>4</b> REMOTE SENSOR</li> <li><b>5</b> LEFT/RIGHT SPEAKER</li> <li><b>6</b> SUBWOOFER</li> <li><b>7</b> LCD (DISPLAY WINDOW)</li> <li><b>8</b> VOLUME (◀/▶) button</li> <li><b>9</b> CD OPEN/CLOSE (▲ PUSH EJECT) button</li> <li><b>10</b> POWER WOOFER button</li> <li><b>11</b> • TAPE button</li> <li>• CD button</li> <li>• TUNER/BAND button</li> <li>• CD SYNC. button</li> <li>• TAPE SPEED button</li> </ul> | <ul style="list-style-type: none"> <li><b>12</b> RECORD/RECORD PAUSE (REC/PAUSE) button</li> <li><b>13</b> PROGRAM/MEMORY (PROG./MEMORY) button</li> <li><b>14</b> • TUNING/TIME(-/+), CD SKIP/SEARCH (-/+), TAPE REWIND/FAST FORWARD (◀◀/▶▶) buttons</li> <li>• PRESET(UP/DOWN), CD PLAY (B) , TAPE PLAY (▶) [TAPE REVERSE PLAY (◀)button: LPC-LM445A/X] buttons.</li> <li>• STOP (■)/CLEAR button</li> <li><b>15</b> FM MODE/RIF/REPEAT button</li> <li><b>16</b> • SET/CD(⏏) button</li> <li>• TAPE MODE button : LPC-LM445A/X</li> <li>• COUNTER RESET (COUNT. RESET) button</li> <li><b>17</b> XDSS button</li> </ul> |
|--|--|

## Rear Panel

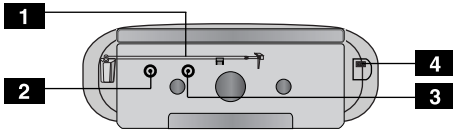

- 1** FM ANTENNA
- 2** MICROPHONE SOCKET -  $\phi$  3.5mm. (OPTIONAL)
- 3** HEADPHONE SOCKET (PHONES) -  $\phi$  3.5mm.
- 4** AC POWER INPUT SOCKET

## Bottom Panel

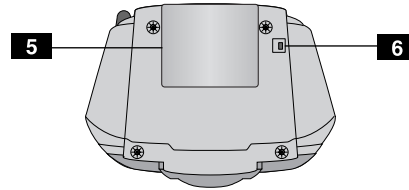

- 5** BATTERY COMPARTMENT
- 6** VOLTAGE SELECTOR : OPTIONAL

## Remote Control

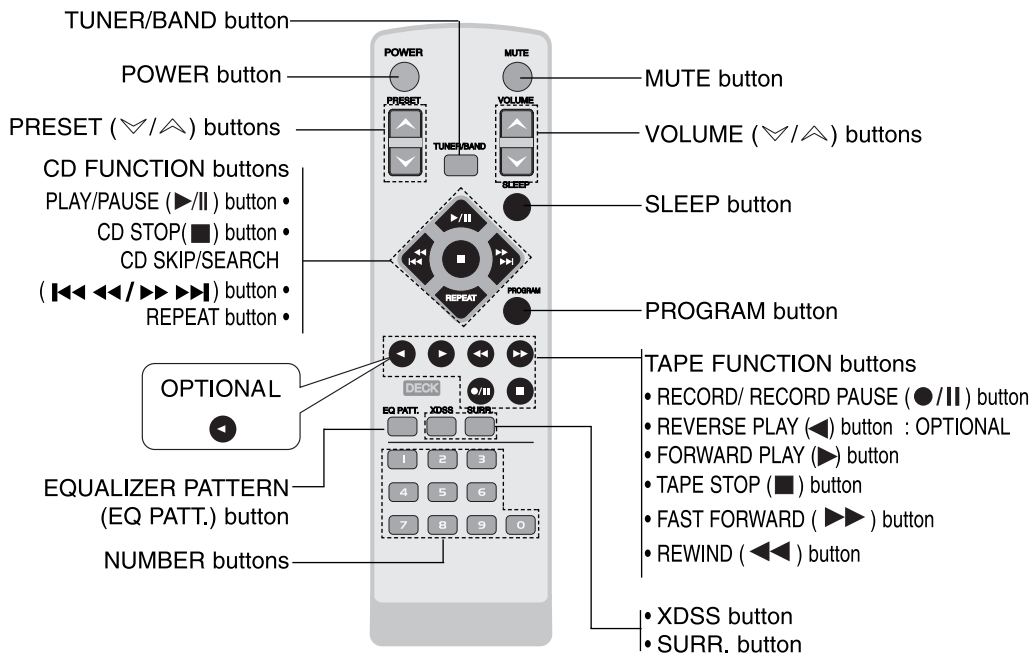





# SECTION 2. ELECTRICAL

## □ ADJUSTMENTS

### 1.TAPE DECK ADJUSTMENT

DECK MODE	TEST TAPE	TEST POINT	ADJUSTMENT	ADJUST FOR
PLAY BACK	MTT-114	L/R Output	Azimuth adjusting screw	L/R Maximum

### 2.RECORD BIAS ADJUSTMENT

DECK MODE	TEST TAPE	TEST POINT	ADJUSTMENT	ADJUST FOR
REC MODE	MTT-5511	C465 OR C415(DECK CIRCUIT B- POINT)	L405 AUTO-RVS AUTO-STOP	75KHz±5KHz 65KHz±5KHz

### 3.TAPE SPEED ADJUSTMENT

DECK MODE	TEST TAPE	TEST POINT	ADJUSTMENT	ADJUST FOR
PLAYBACK	MTT-111	L/R Output	SR490	3kHz±50Hz

# □ TROUBLESHOOTING GUIDE

## • CD PART

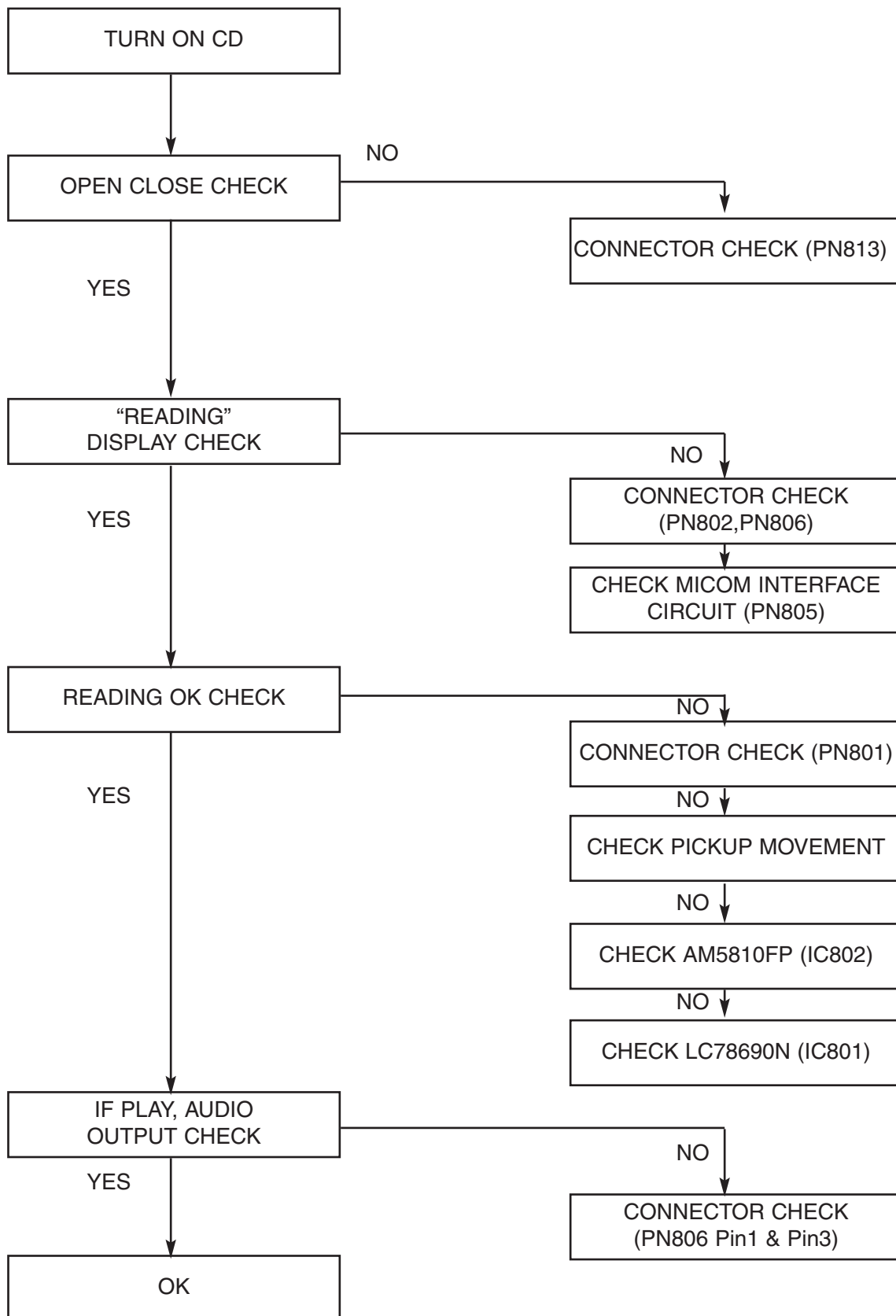

**OPEN COLOSE NG**

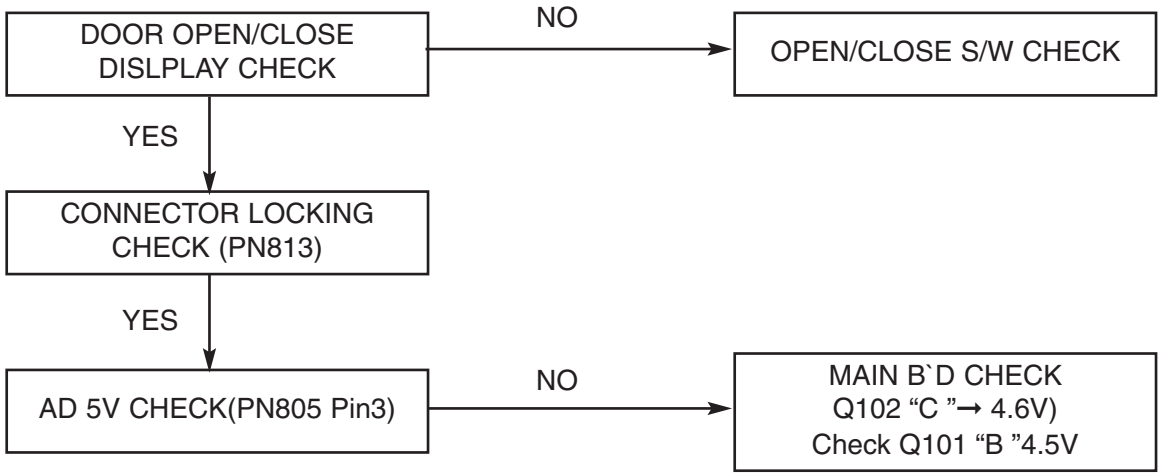

**“READING ”DISLPLAY CHECK (=ONLY “CD ”DISPLAY)**

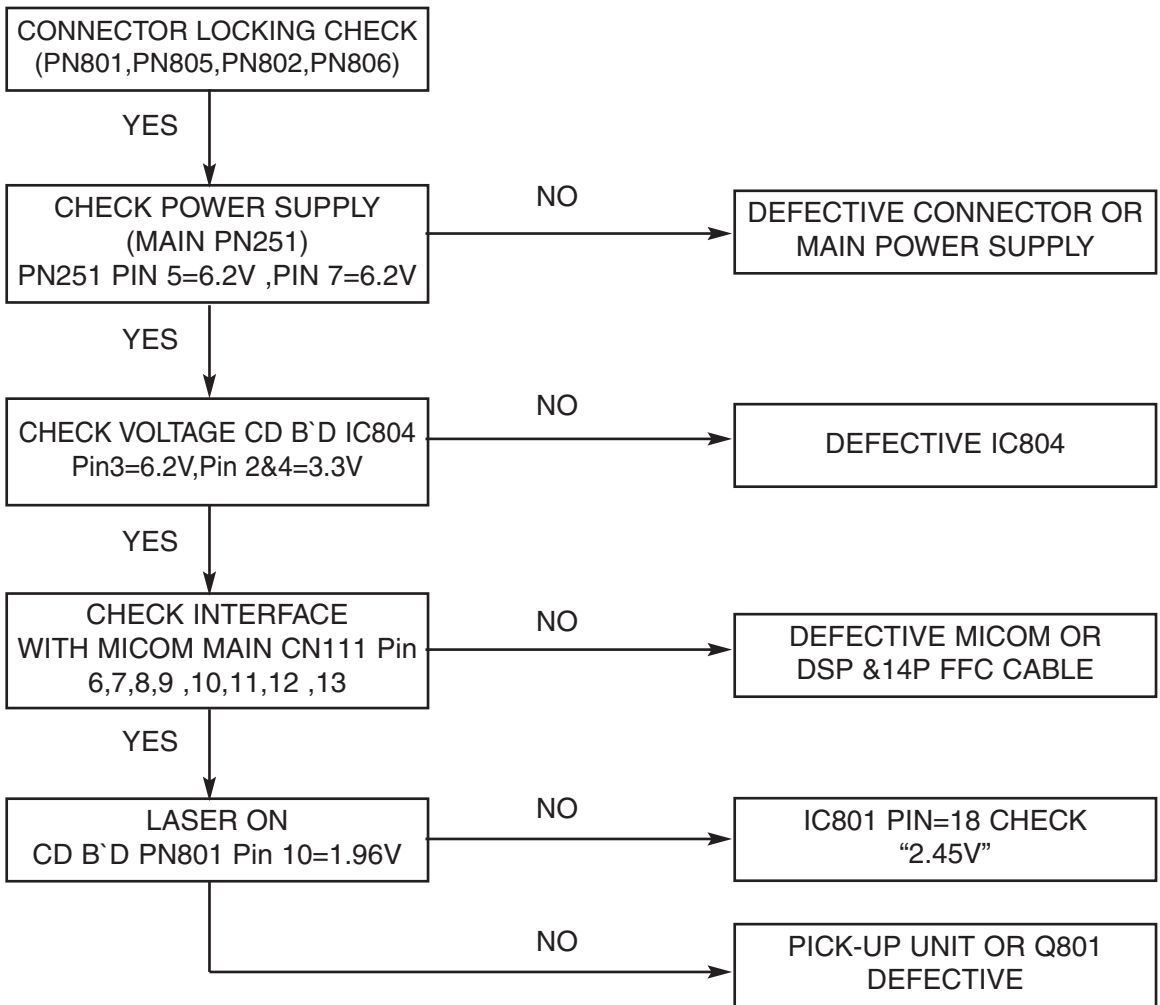

**READING OK CHECK (=“NO DISC ”DISPLAY)**

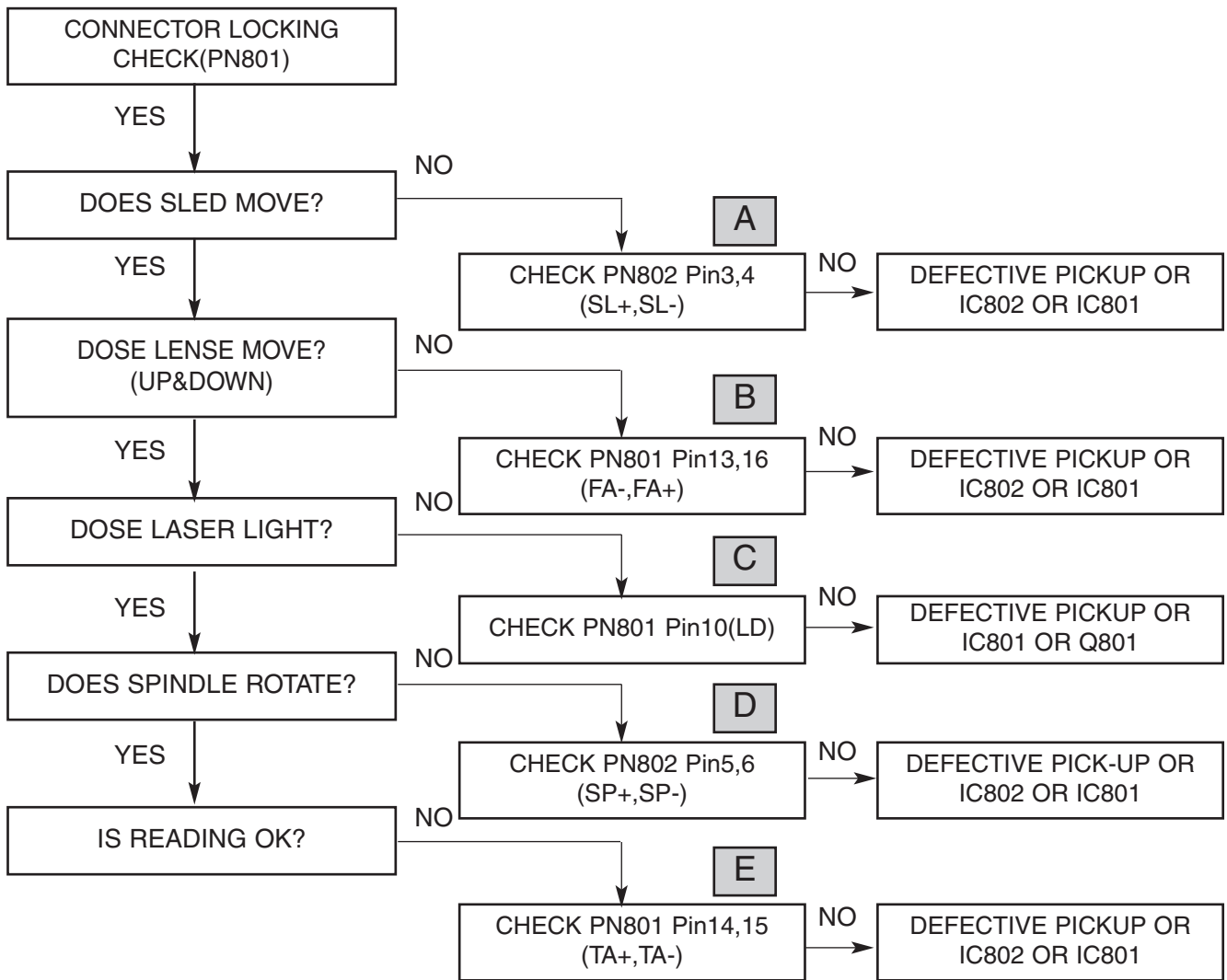

READING OK CHECK #A(="NO DISC "DISPLAY)

**A**

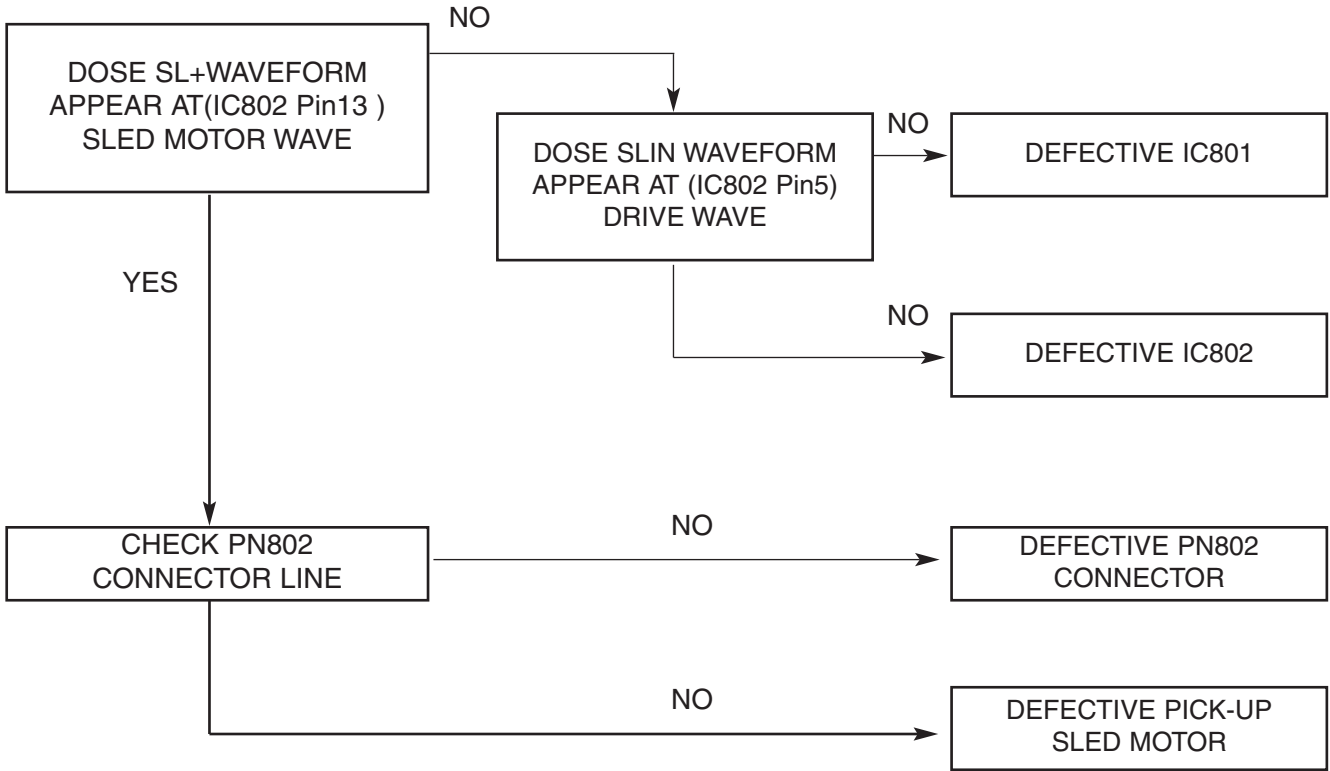

READING OK CHECK #B(="NO DISC "DISPLAY)

**B**

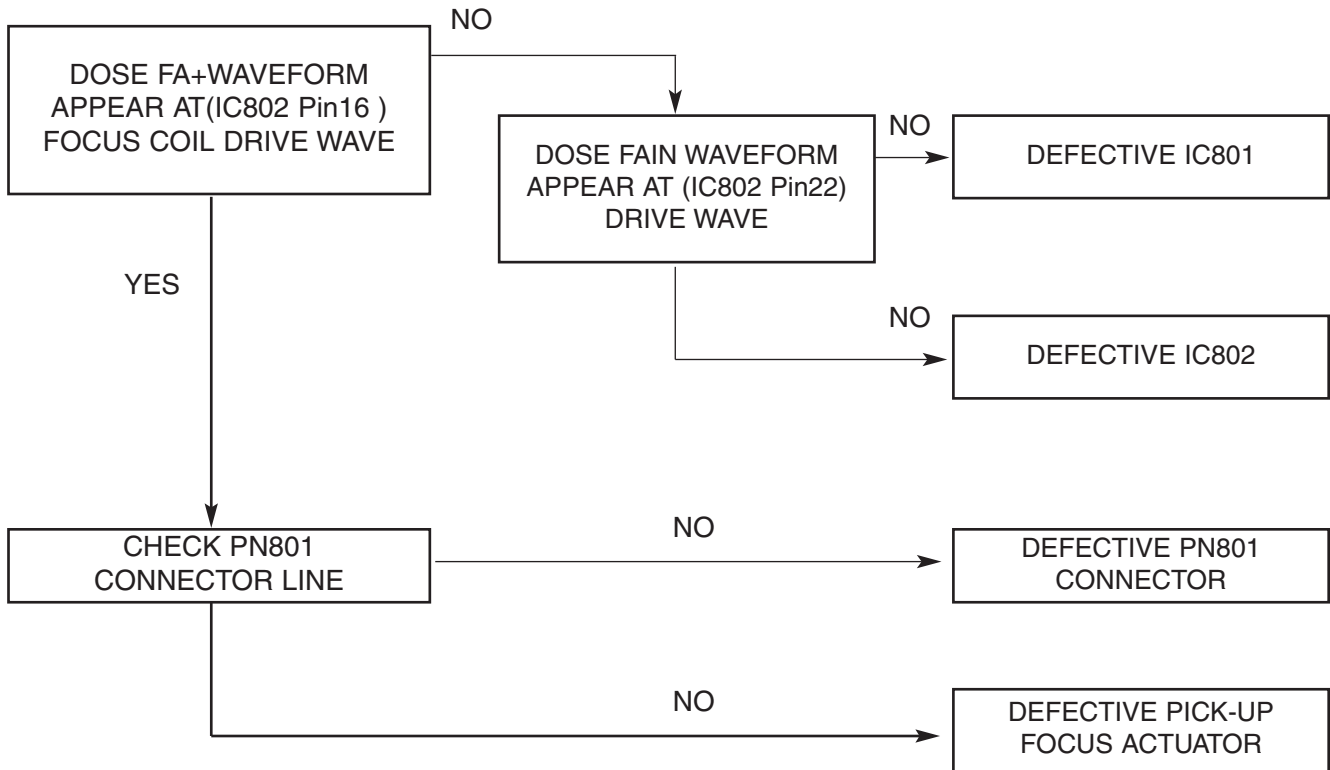

READING OK CHECK #C(="NO DISC "DISPLAY)

C

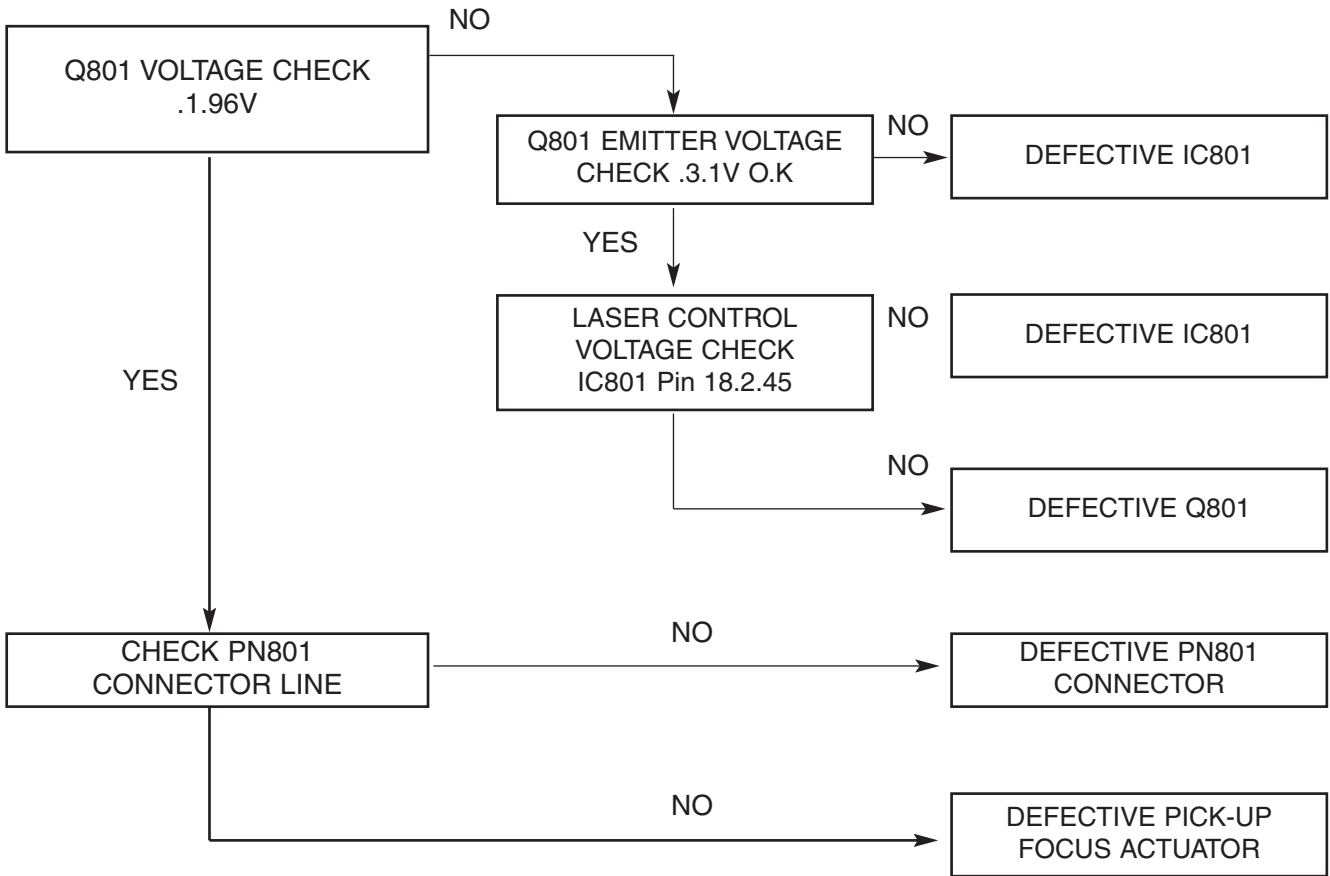



READING OK CHECK #D(="NO DISC "DISPLAY)

D

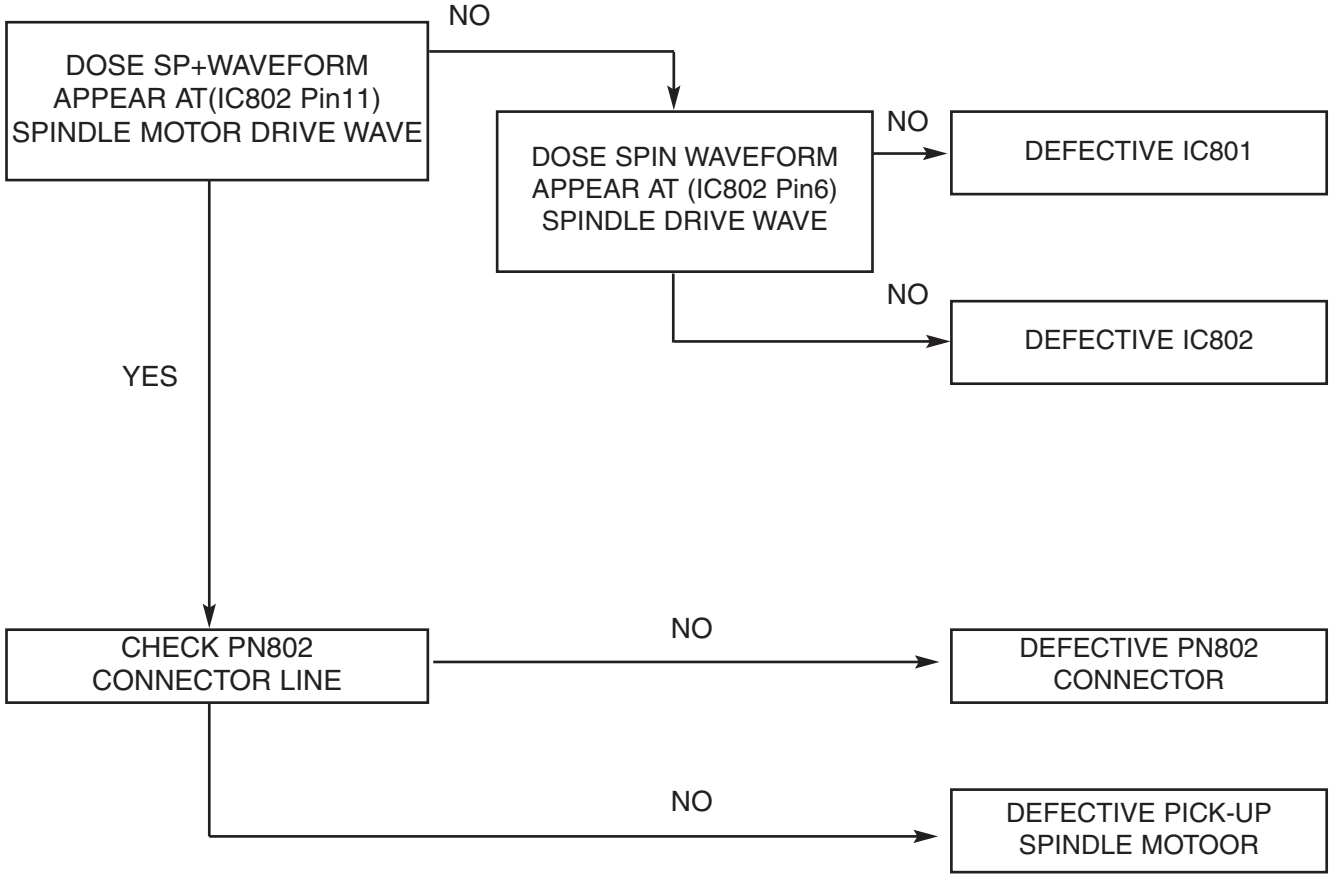

READING OK CHECK #E(="NO DISC "DISPLAY)

**E**

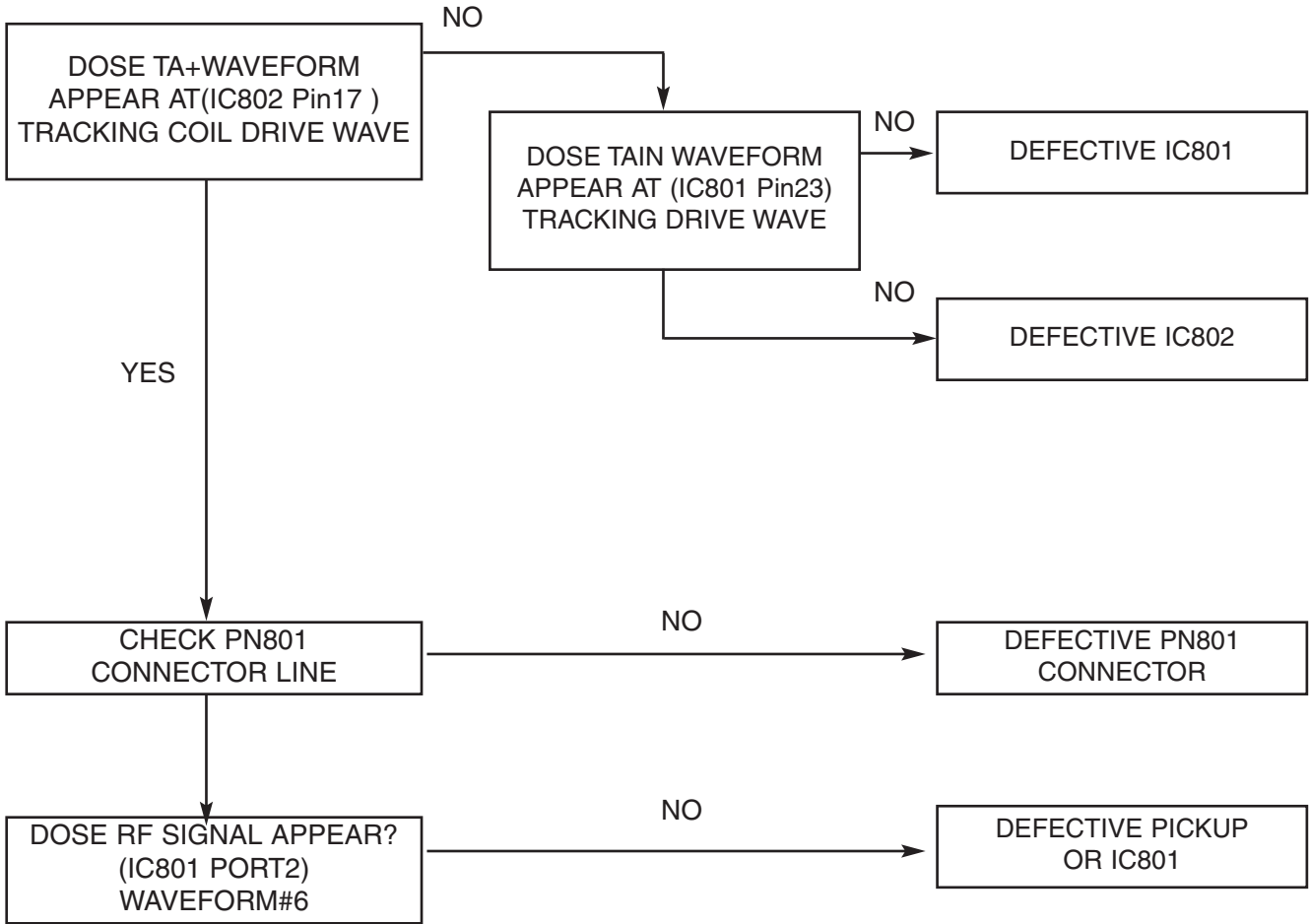

# • MAIN POWER

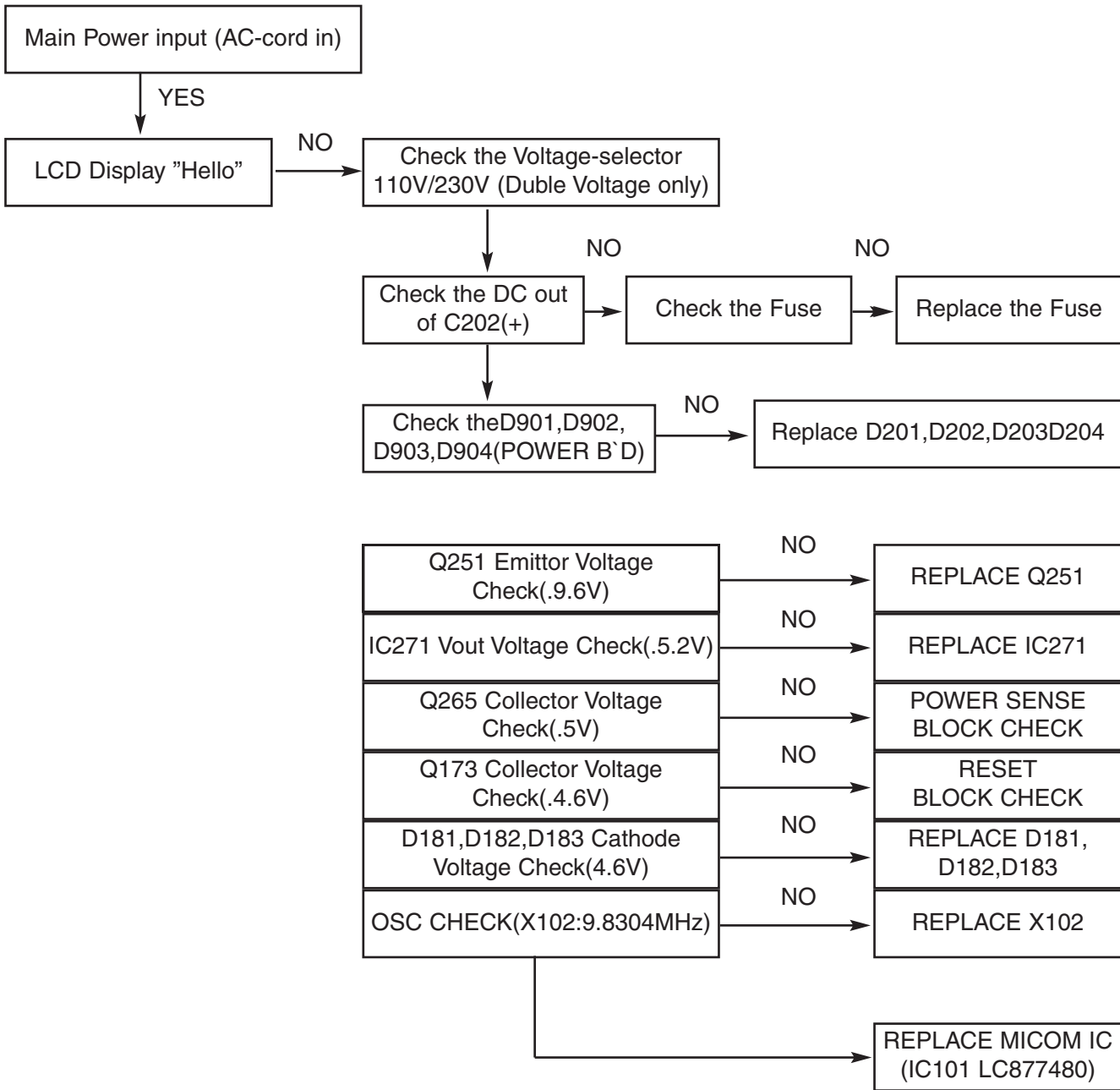

## • MUTING CIRCUIT(MUTE)

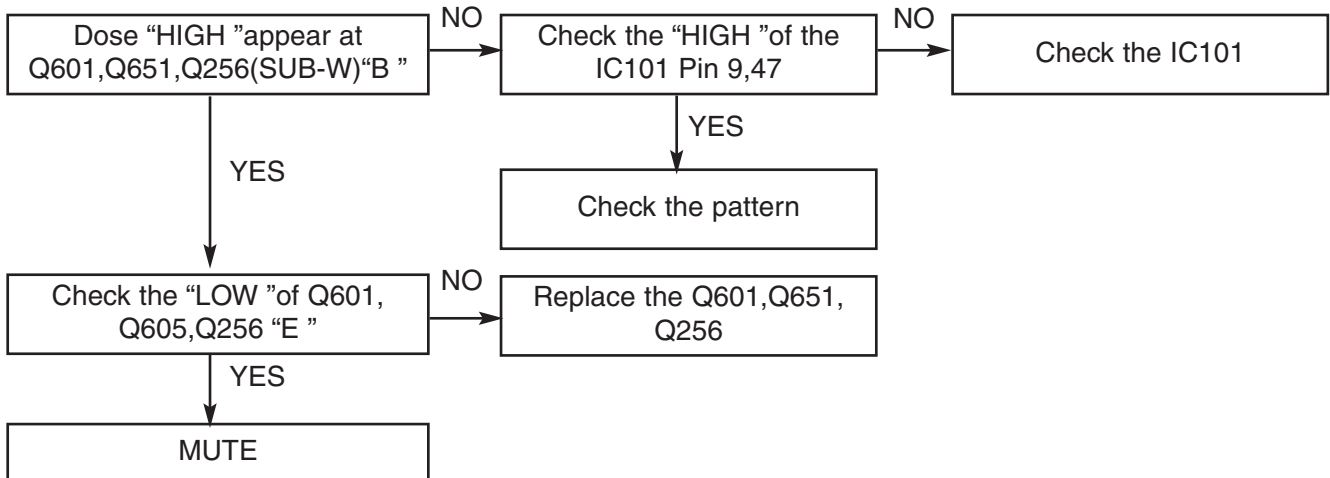

## • FUNCTION MODE AUDIO ABNORMAL

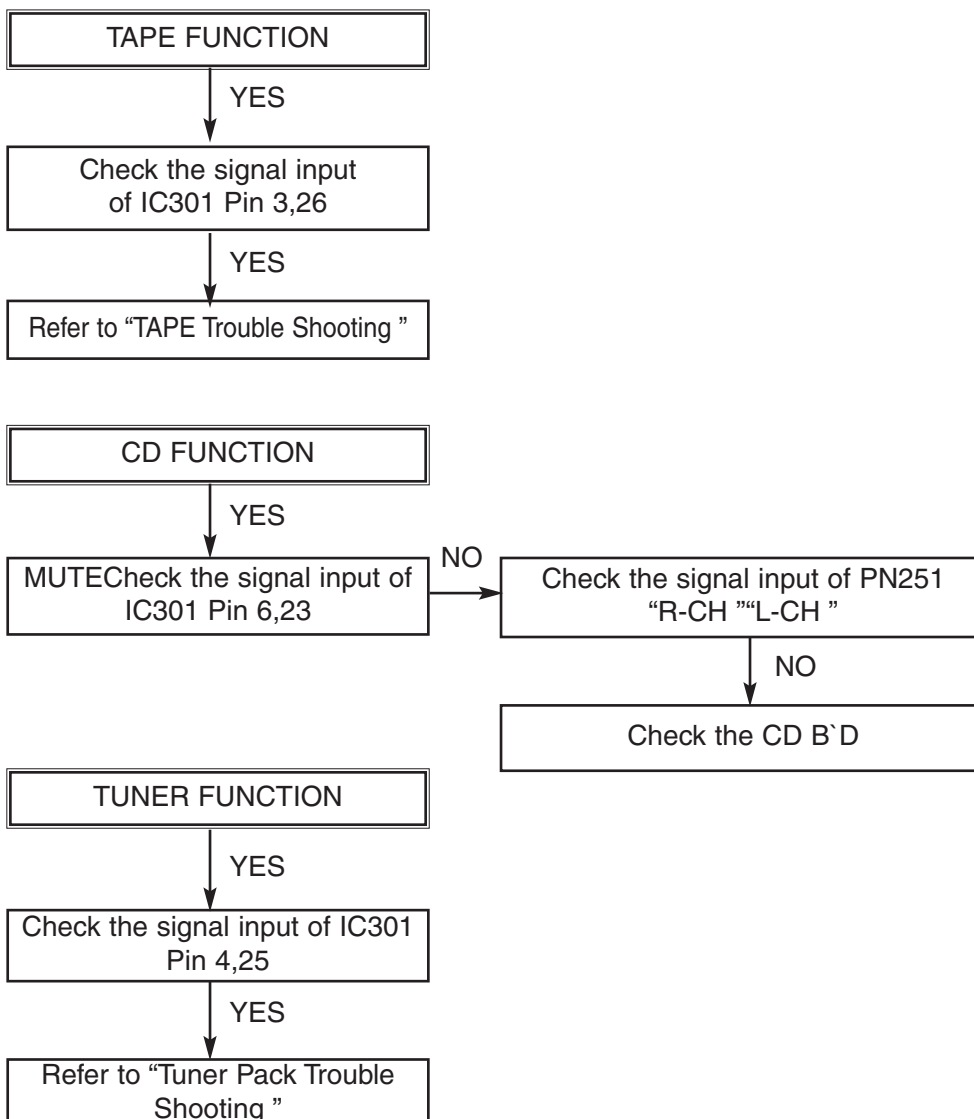

# • IC301 TROUBLESHOOTING

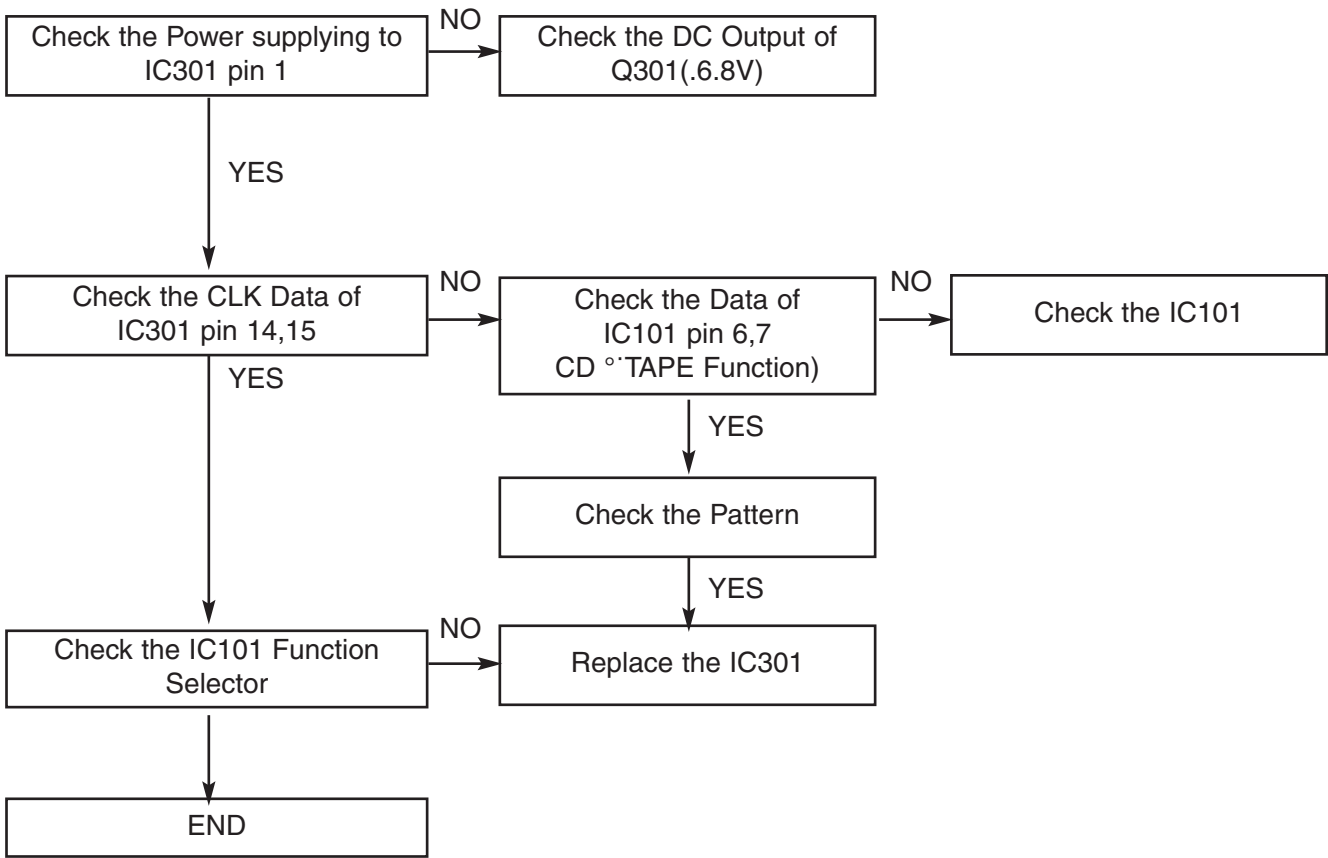

# • TUNER PACK TROUBLESHOOTING

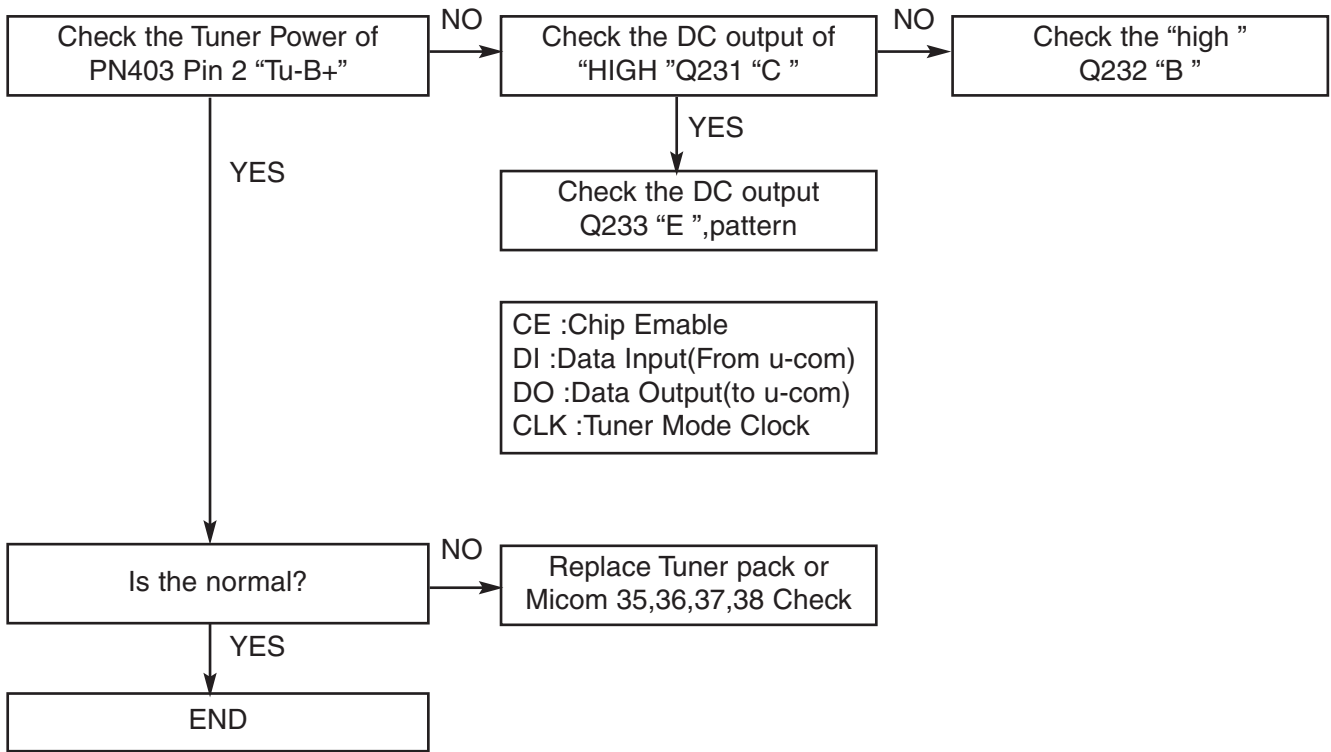

# • TAPE TROUBLESHOOTING

## 1) Play

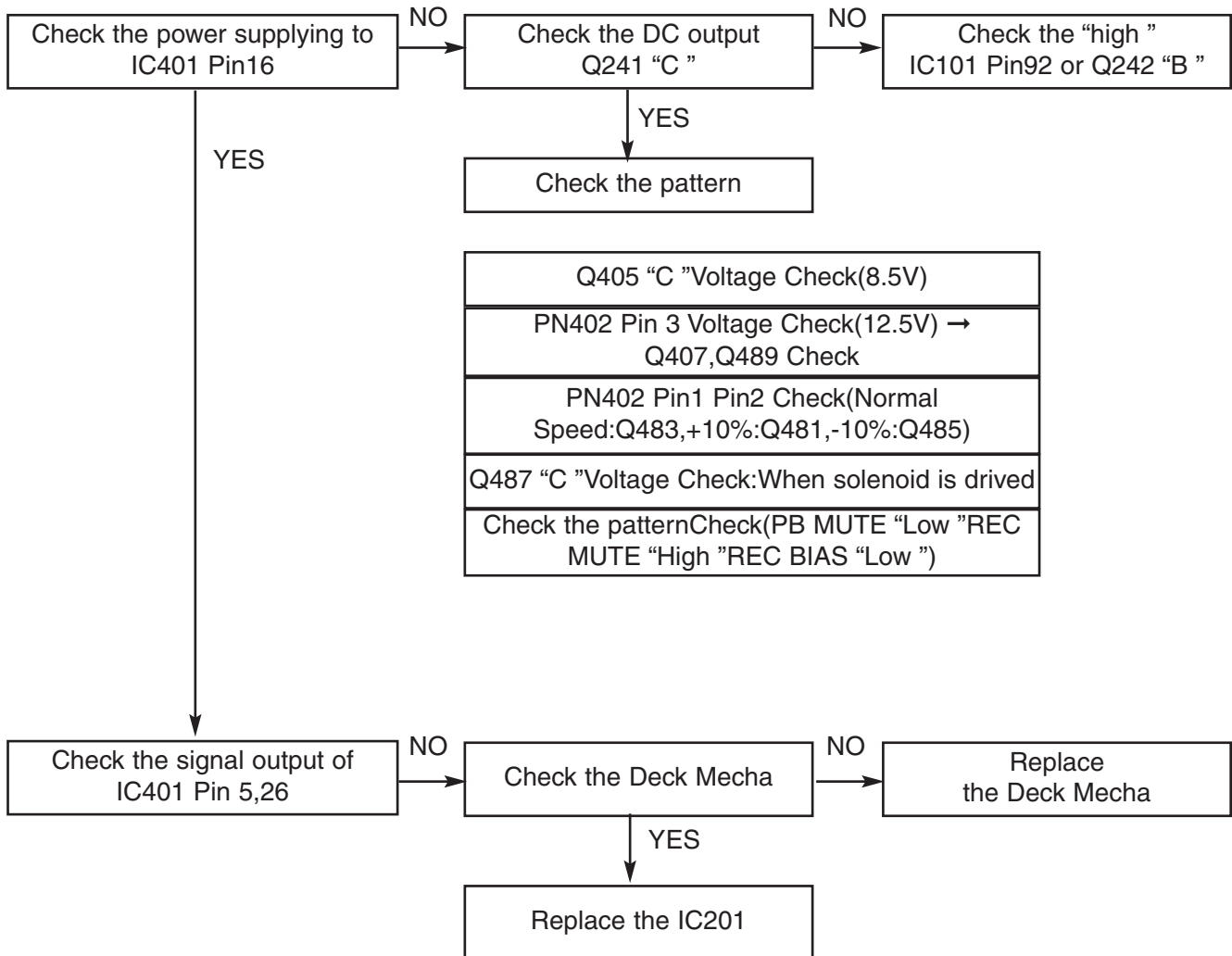

## 2) REC

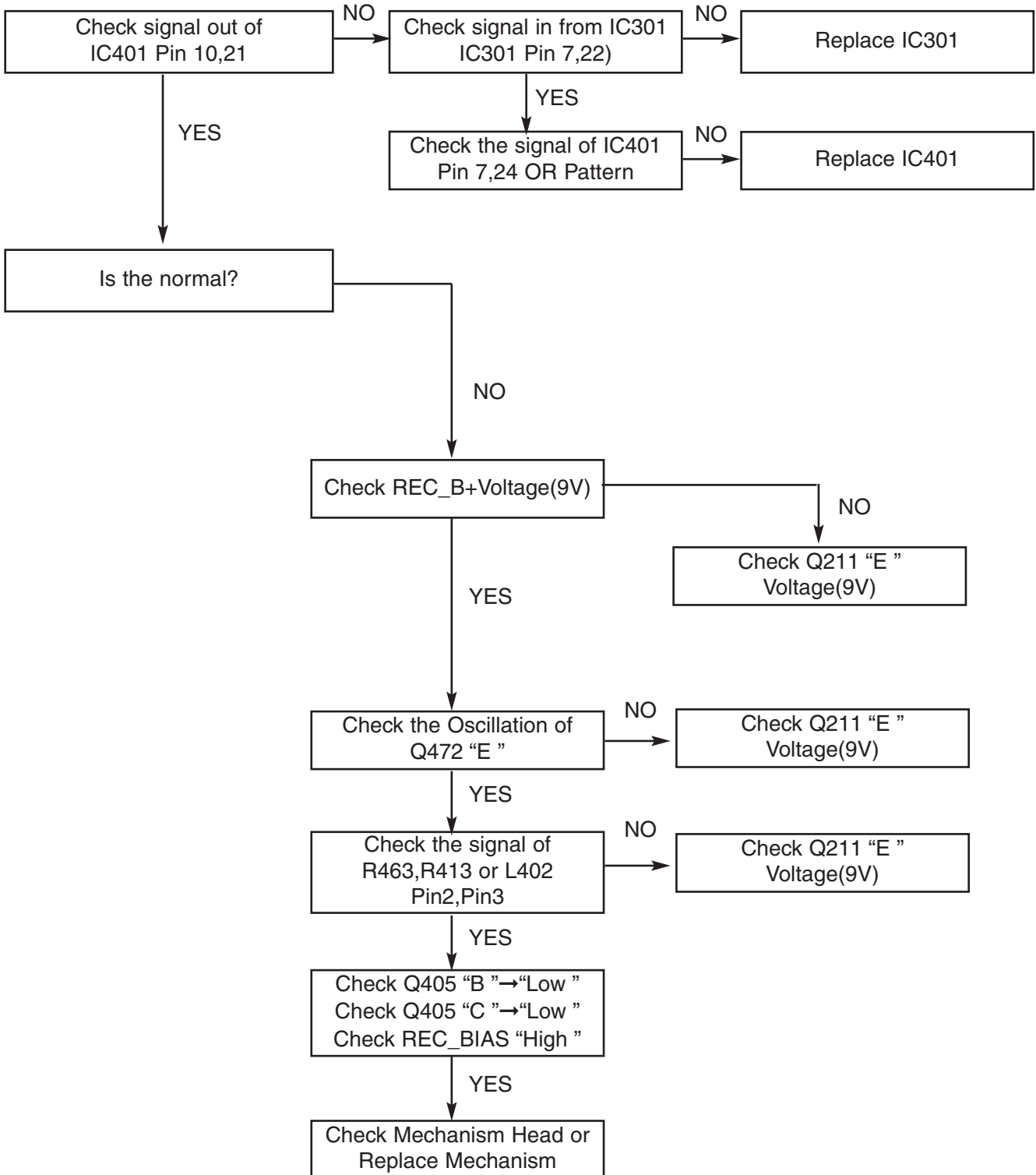



# • POWER IC TROUBLESHOOTING

## 1)2CH(L/R)

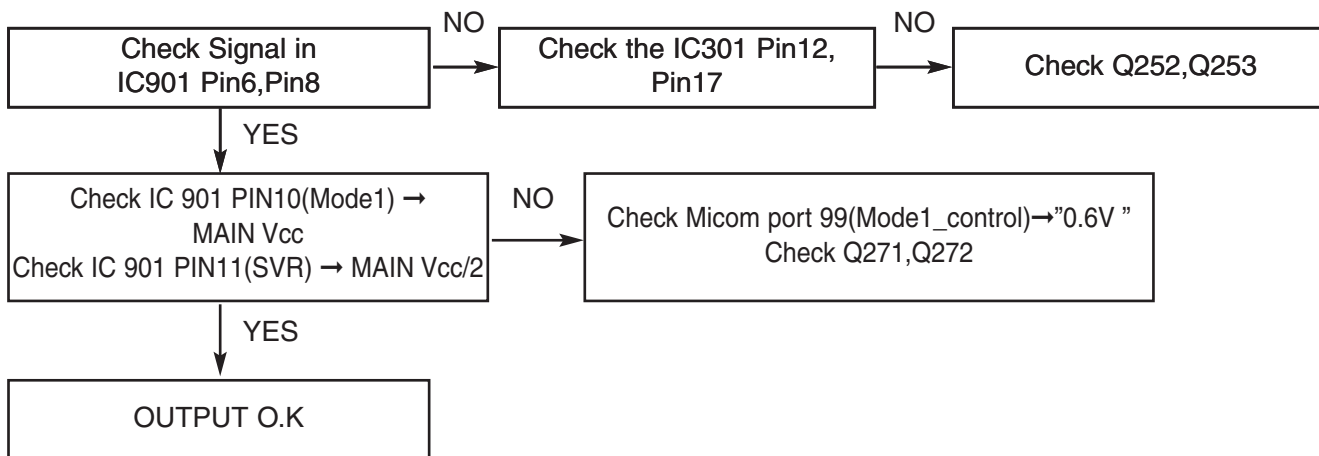

## 2)SUB-WOOFER

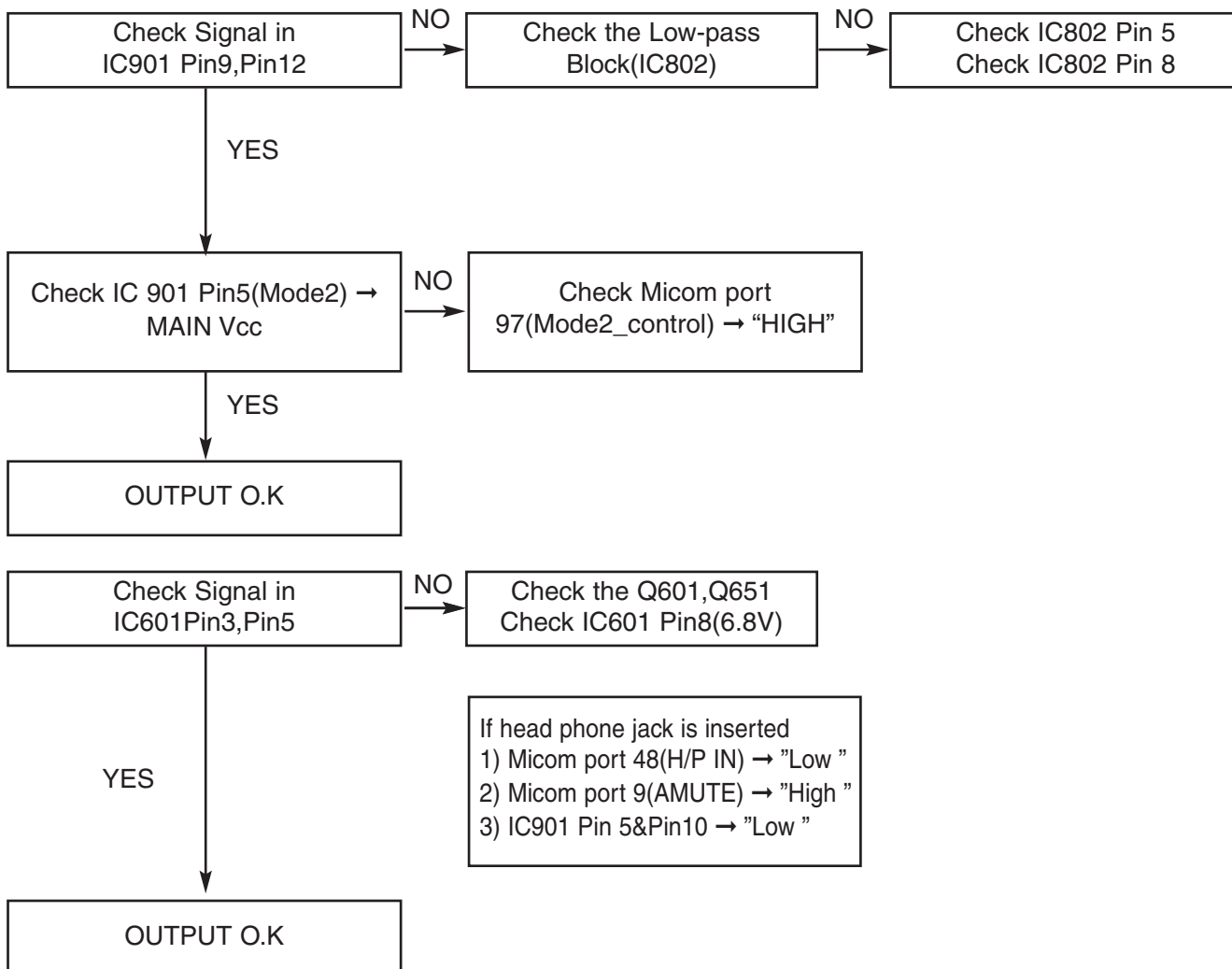

# INTERNAL BLOCK DIAGRAM OF ICs

## ■ TDA8947J

### • BLOCK DIAGRAM

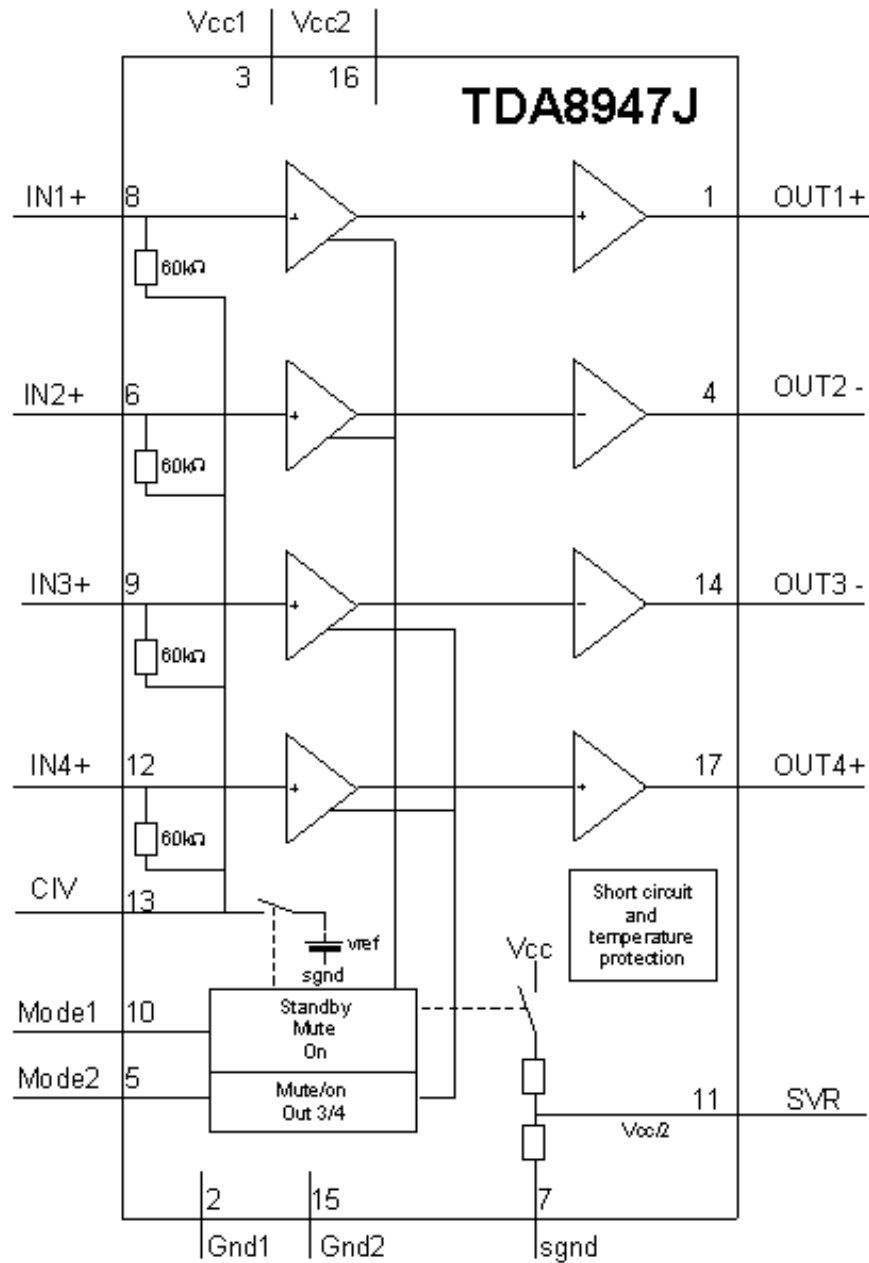

• PINNING INFORMATION

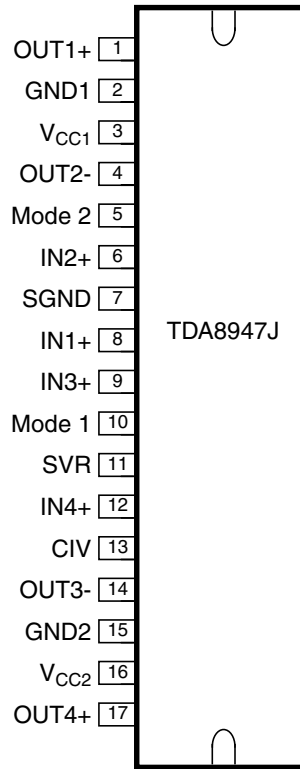

**Table 3: Pin description**

Symbol	Pin	Description
OUT1+	1	non inverted loudspeaker terminal 1
GND1	2	ground channel 1
V <sub>CC1</sub>	3	supply voltage channel 1
OUT2-	4	inverted loudspeaker terminal 2
Mode 2	5	mode selection of subwoofer (channel 3/4)
IN2+	6	input 2
SGND	7	signal ground
IN1+	8	input 1
IN3+	9	input 3
Mode 1	10	mode selection input (standby, mute, operating)
SVR	11	half supply voltage decoupling (ripple rejection)
IN4+	12	input 4
CIV	13	Common input voltage decoupling
OUT3-	14	inverted loudspeaker terminal 3
GND2	15	ground channel 2
V <sub>CC2</sub>	16	supply voltage channel 2
OUT4+	17	non inverted loudspeaker terminal 4

**TDA7468D**  
 • **BLOCK DIAGRAM**

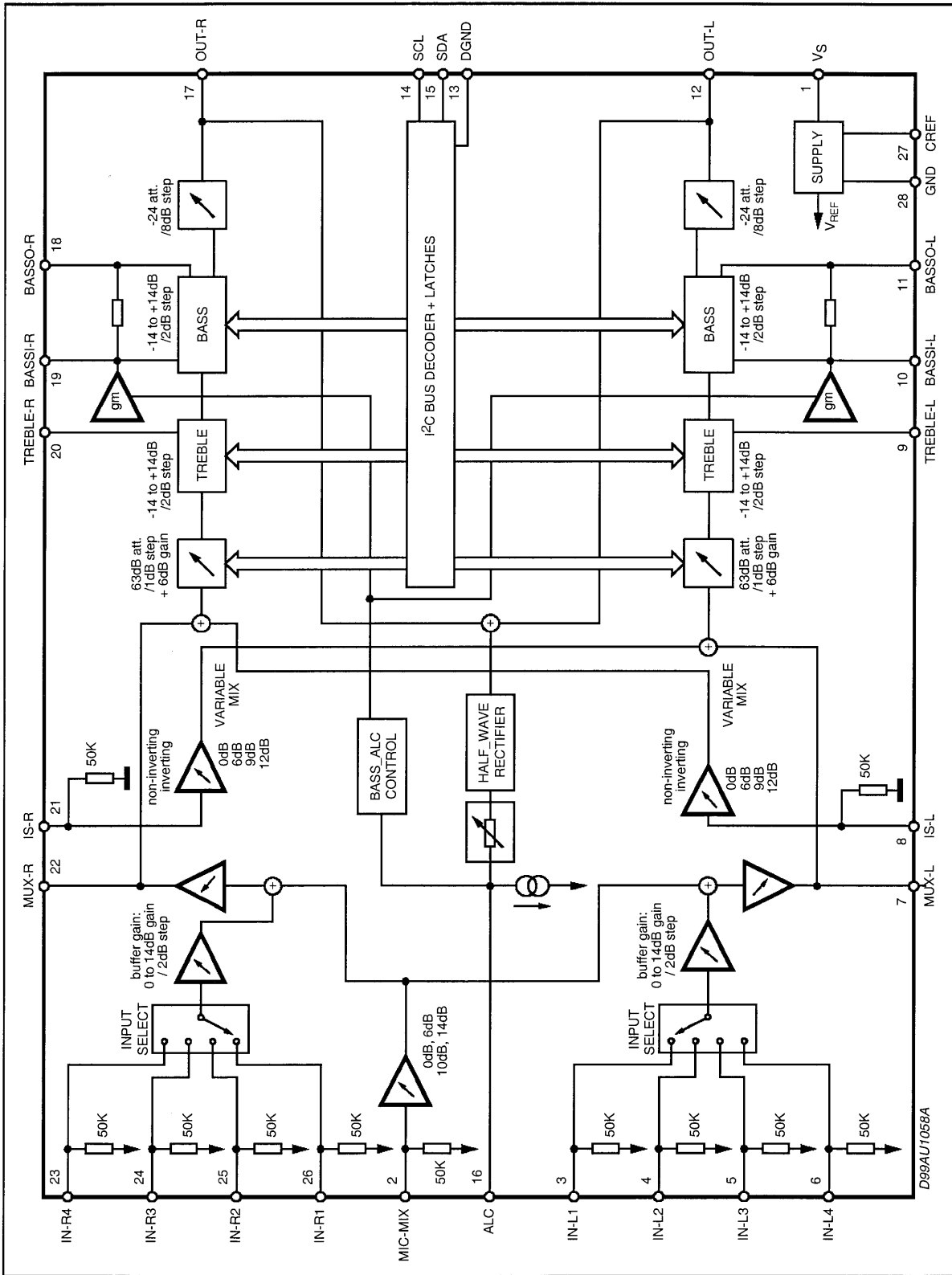

• PIN CONNECTION

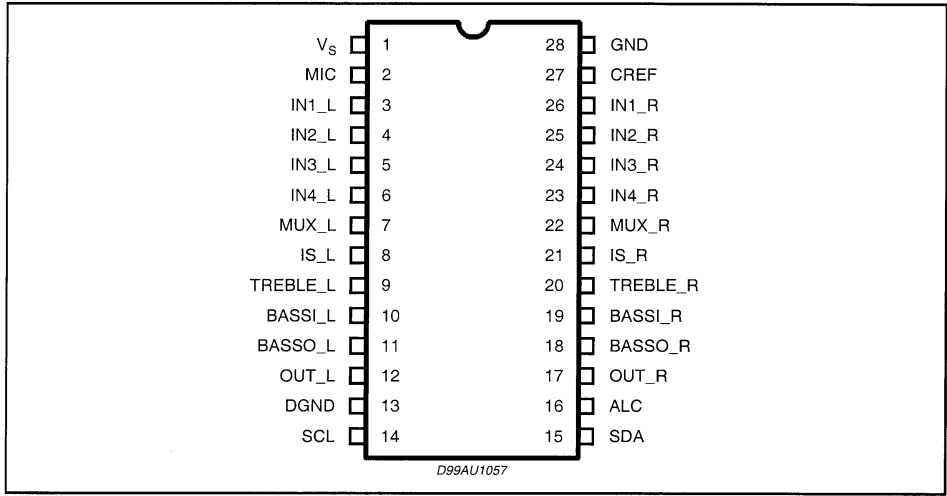

■ HA12237F

• BLOCK DIAGRAM

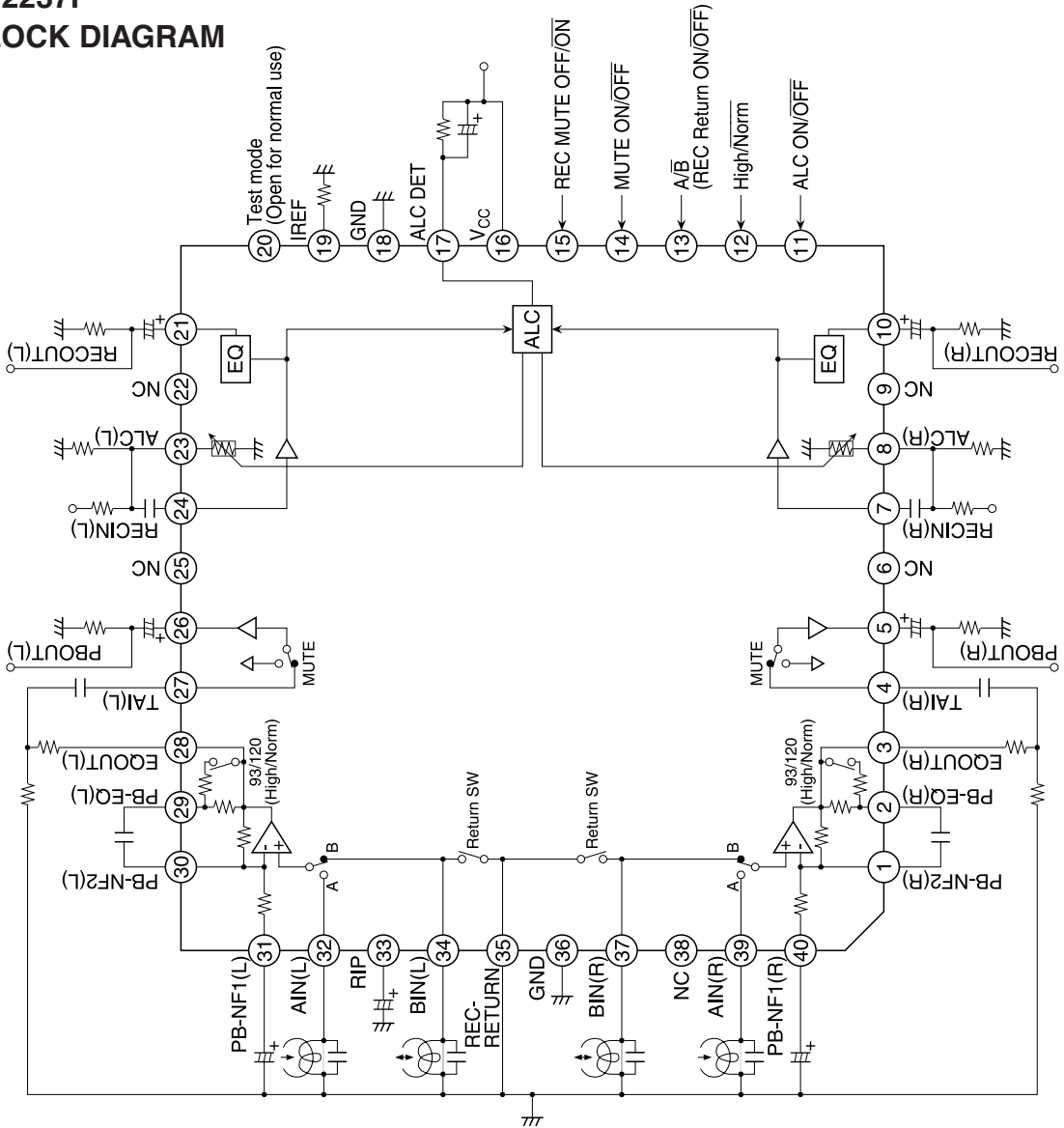

# AM5810(Motor Driver ICs)

## • BLOCK DIAGRAM

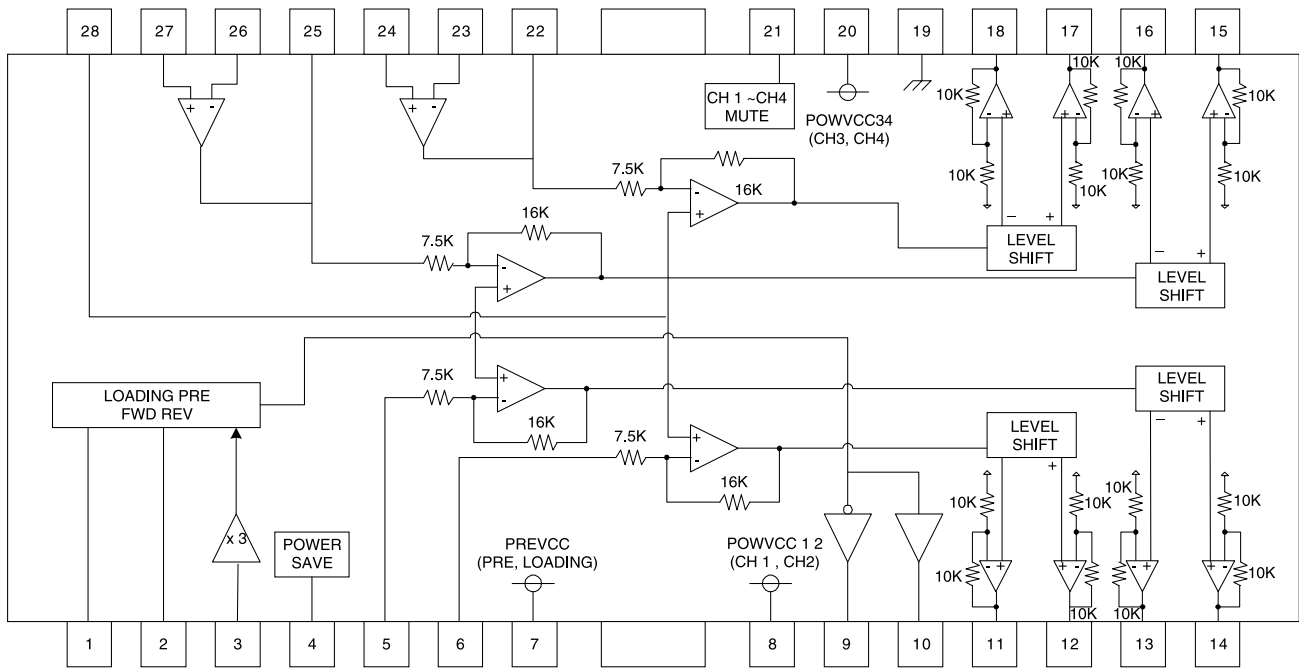

## • PIN CONFIGURATION

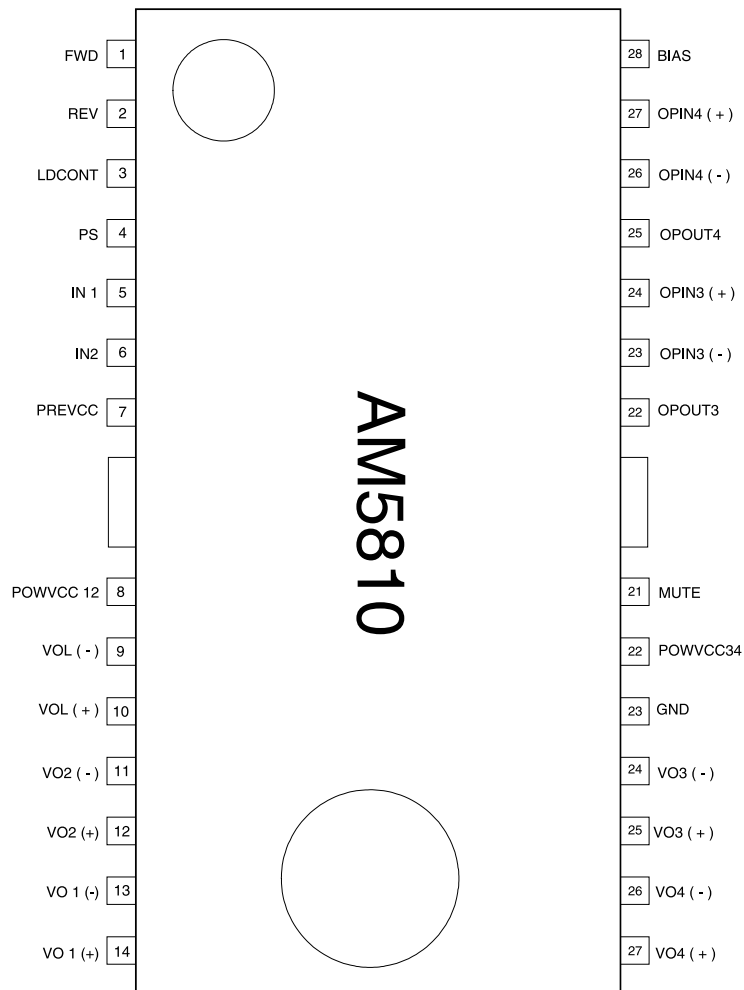

## • PIN DESCRIPTION

PIN No	Pin Name	Description
1	FWD	Input for loading forward
2	REV	Input for loading reverse
3	LDCONT	Output control terminal for loading
4	PS	Control terminal for power saving mode
5	IN1	Input 1 of CH1
6	IN2	Input 2 of CH2
7	PREVCC	Pre and loading unit power supply input terminal
8	POWVCC12	Power unit power supply input terminal (CH1, CH2)
9	VOL (-)	Inverted output of loading
10	VOL (+)	Not inverted output of loading
11	VO2 (-)	Inverted output of CH2
12	VO2 (+)	Not inverted output of CH2
13	VO1 (-)	Inverted output of CH1
14	VO1 (+)	Not inverted output of CH1
15	VO4 (+)	Not inverted output of CH4
16	VO4 (-)	Inverted output of CH4
17	VO3 (+)	Not inverted output of CH3
18	VO3 (-)	Inverted output of CH3
19	GND	Substrate ground
20	POWVCC34	Power unit power supply input terminal (CH3, CH4)
21	MUTE	Input for mute control
22	OPOUT3	Output of CH3 OP-ANP
23	OPIN3 (-)	Inverting input of CH3 OP-ANP
24	OPIN3 (+)	Not inverting input of CH3 OP-ANP
25	OPOUT4	Output of CH4 OP-ANP
26	OPIN4 (-)	Inverting input of CH4 OP-ANP
27	OPIN4 (+)	Not inverting input of CH4 OP-ANP
28	BIAS	Input of Bias-Amplifier

# □ IC/TR VOLTAGE & PIN DESCRIPTION

MAIN SECTION

(Measurement Condition:AC 230V/50Hz)

IC301

(Volume 10, Power on, Unload)

1	2	3	4	5	6	7	8	9	10	11	12	13	14	15
0	6.58	3.28	3.28	0	3.28	3.28	3.28	3.28	3.28	3.28	3.28	0	0	0
16	17	18	19	20	21	22	23	24	25	26	27	28		
3.24	3.28	3.28	3.28	3.28	3.28	3.28	3.28	0	3.28	3.28	3.28	0		

IC601

1	2	3	4	5	6	7	8
3.62	3.62	3.62	0	3.61	3.61	3.62	6.59

IC802

1	2	3	4	5	6	7	8
3.62	3.62	3.59	0	3.51	3.62	3.62	6.59

IC901

1	2	3	4	5	6	7	8	9	10	11	12	13	14	15
9.23	0	18.78	9.24	0	3.5	0	3.28	3.25	17.32	10.65	3.14	3.21	9.25	0
16	17													
18.79	9.24													

(5PIN:WOOFER ON 18.67V)

IC271

1(IN)	2(GND)	3(OUT)
9.41	0.21	5.22

Q301

E	C	B
6.58	8.54	7.3

Q302

E	C	B
0	1.19	0.65

Q303

E	C	B
3.19	4.63	3.76

Q601

E	C	B
0	0	0.65

Q651

E	C	B
0	0	0.65

(MUTE ON)

Q252

E	C	B
0	0	0.65

(MUTE ON)

Q253

E	C	B
0	0	0.65

(MUTE ON)

Q271

E	C	B
0	0	0.69

Q272

E	C	B
0	17.7	0

Q273

E	C	B
0	18.85	0

Q274

E	C	B
0	0	4.36

(S/W ON)

Q257

E	C	B
6.49	18.68	7.11

Q258

E	C	B
6.49	6.48	5.71

(CD MODE)

Q259

E	C	B
0	4.32	4.4

Q256

E	C	B
0	0	0.64

(S/W MUTE)

Q201

E	C	B
18.87	18.83	18.13

Q202

E	C	B
0	0.04	0.66

Q211

E	C	B
9.39	18.83	9.96

Q212

E	C	B
18.68	9.96	18.66

Q213

E	C	B
0	18.65	0

(BAT:4.4V)

Q231

E	C	B
9.4	9.3	8.62

(TUNER MODE)

Q232

E	C	B
0	0	4.38

(TUNER MODE)

Q233

E	C	B
8.26	9.38	8.97

(TUNER MODE)

Q241

E	C	B
9.48	9.47	8.76

(TAPE MODE)

Q242

E	C	B
0	0.09	4.25

(TUNER MODE)

Q263

E	C	B
0	0.63	0

Q262

E	C	B
0	0	0.63

Q265

E	C	B
4.68	4.67	4.13



Q251

E	C	B
9.42	18.12	10.02

DECK SECTION

IC401

1	2	3	4	5	6	7	8	9	10	11	12	13	14	15
0.63	2.98	2.95	4.43	4.51	0	4.2	0	0	4.47	5.79	0	0	0	0
16	17	18	19	20	21	22	23	24	25	26	27	28	29	30
8.86	8.33	0	1.26	3.93	4.45	0	0	4.45	0	4.53	4.45	2.95	2.95	0.63
31	32	33	34	35	36	37	38	39	40					
0.63	0	4.37	0	0	0	0	0	0	0.63	(REC MODE→13P:3.77,14P:4.43,15P:4.32)				

Q401

D	G	S
0	9.38	0

(REC:0V)

Q402

D	G	S
0	9.38	0

(REC:0V)

Q403

D	G	S
0	9.38	0

(REC:0V)

Q404

D	G	S
0	9.38	0

(REC:0V)

Q405

E	C	B
9.42	9.41	0

(REC:9.42/0/9.34)

Q406

E	C	B
0	0	4.35

(REC:0/9.33/0)

Q471

E	C	B
0	0	0

(AM REC&RIF ON:0/0/0.63)

Q472

E	C	B
9.05	9.39	9.38

(REC:1.75/6.57/1.64)

Q473

E	C	B
0	9.06	0

(REC:0/0.86/0.79)

Q481

E	C	B
7.78	7.77	7.14

(SPEED 10% UP)

Q482

E	C	B
0	0	4.36

(SPEED 10% UP)

Q483

E	C	B
8.27	8.25	7.61

(NORMAL SPEED)

Q484

E	C	B
0	0	4.37

(NORMAL SPEED)

Q485

E	C	B
8.7	8.67	8.04

(SPEED 10% DOWN)

Q486

E	C	B
0	0	4.37

(SPEED 10% DOWN)

Q487

E	C	B
18.32	18.3	17.8

(SOLENOID ON)

Q488

E	C	B
0	0	4.37

(SOLENOID ON)

Q489

E	C	B
12.78	12.75	12.04

(TAPE PLAY BACK & REC)

Q490

E	C	B
0	0	4.12

(TAPE PLAY BACK & REC)

Q407

E	C	B
12.77	18.31	13.34

MICOM SECTION

IC101

1	2	3	4	5	6	7	8	9	10	11	12	13	14	15
4.47	CLOCK	CLOCK	CLOCK	CLOCK	CLOCK	CLOCK	N.C	4.53	N.C	4.48	X-TAL	X-TAL	0	X-TAL
16	17	18	19	20	21	22	23	24	25	26	27	28	29	30
X-TAL	4.47	4.49	4.49	2.97	1.9	1.9	CLOCK	CLOCK	2.74	4.67	3.17	4.56	4.47	0
31	32	33	34	35	36	37	38	39	40	41	42	43	44	45
0	4.53	4.53	4.53	CLOCK	CLOCK	CLOCK	CLOCK	0	4.05	0	0	0	4.53	4.53
46	47	48	49	50	51	52	53	54	55	56	57	58	59	60
4.53	4.53	4.51	N.C	SEG	SEG	SEG	SEG	4.6	0	SEG	SEG	SEG	SEG	SEG
61	62	63	64	65	66	67	68	69	70	71	72	73	74	75
SEG	N.C	SEG	SEG	SEG	SEG	SEG	SEG	SEG	SEG	SEG	SEG	SEG	SEG	SEG
76	77	78	79	80	81	82	83	84	85	86	87	88	89	90
SEG	SEG	SEG	SEG	4.57	0	0	COM	COM	COM	COM	0	4.53	0	4.63

91	92	93	94	95	96	97	98	99	100
4.53	4.53	N.C	N.C	4.53	4.53	4.53	4.53	4.53	4.57

(1P:CD MODE,9P:MUTE ON,20P:CD DOOR OPEN 4.54 CLOSE 2.97,21P:PLAY 1.9 STOP 2.39 ,22P:F 2.8 R 2.39 F&R 1.87  
32P: PB 4.53 REC 0,33P:SOLENOID ON,34P:MOTOR ON,41P:AC 0 DC 4.5,42P:PB 0 REC 4.53,43P: AM REC& RIF ON 4.53  
44P:SPEED 10% UP,45P:NORMAL SPEED,46P:SPEED 10% DOWN,47P:WOOFER MUTE ON,48P:H/P OUT 4.51 H/P IN 1.2  
87P: PB 0 REC 4.53,91P:TUNER MODE,92P:TAPE MODE,95P:CD MODE,97P:WOOFER ON,98P:H/P MUTE ON,100P:CD MODE)

Q171

E	C	B
5.2	5.2	0

Q172

E	C	B
0	0	4.69

Q173

E	C	B
0	4.47	0

Q101

E	C	B
0	0	4.51

Q102

E	C	B
4.56	4.55	3.87

Q151

E	C	B
0	0	0.72

FONRT SECTION

Q111

E	C	B
0	0.24	4.5

(DC BAT:0/4.53/0)

CD SECTION

IC804

1	2	3	4
0	3.3	6.48	3.3

(CD PLAY MODE)

Q801

E	C	B
3.1	3.05	0

(CD PLAY MODE)



# □ BLOCK DIAGRAM

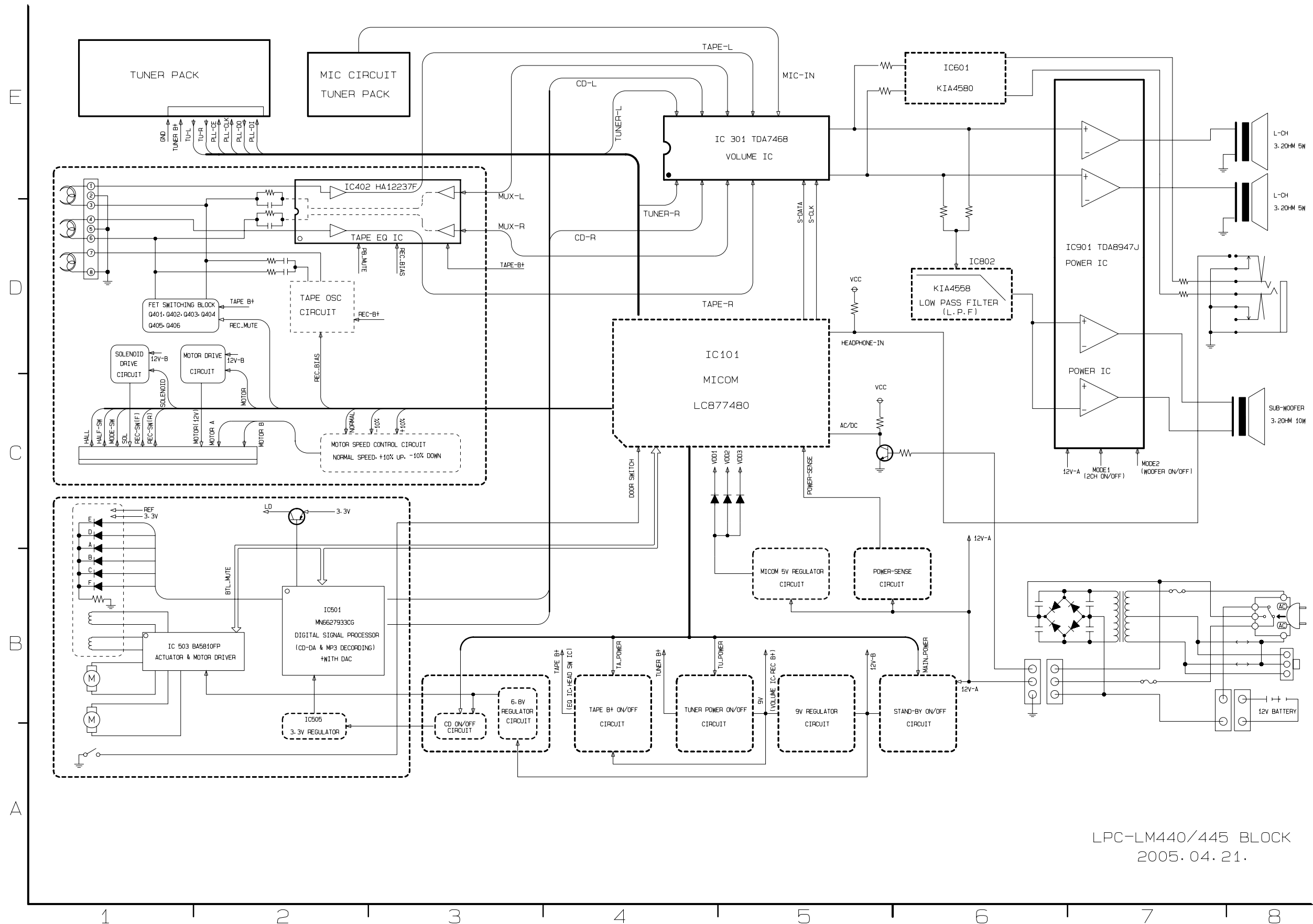

LPC-LM440/445 BLOCK  
2005.04.21.



# MICOM SCHEMATIC DIAGRAM

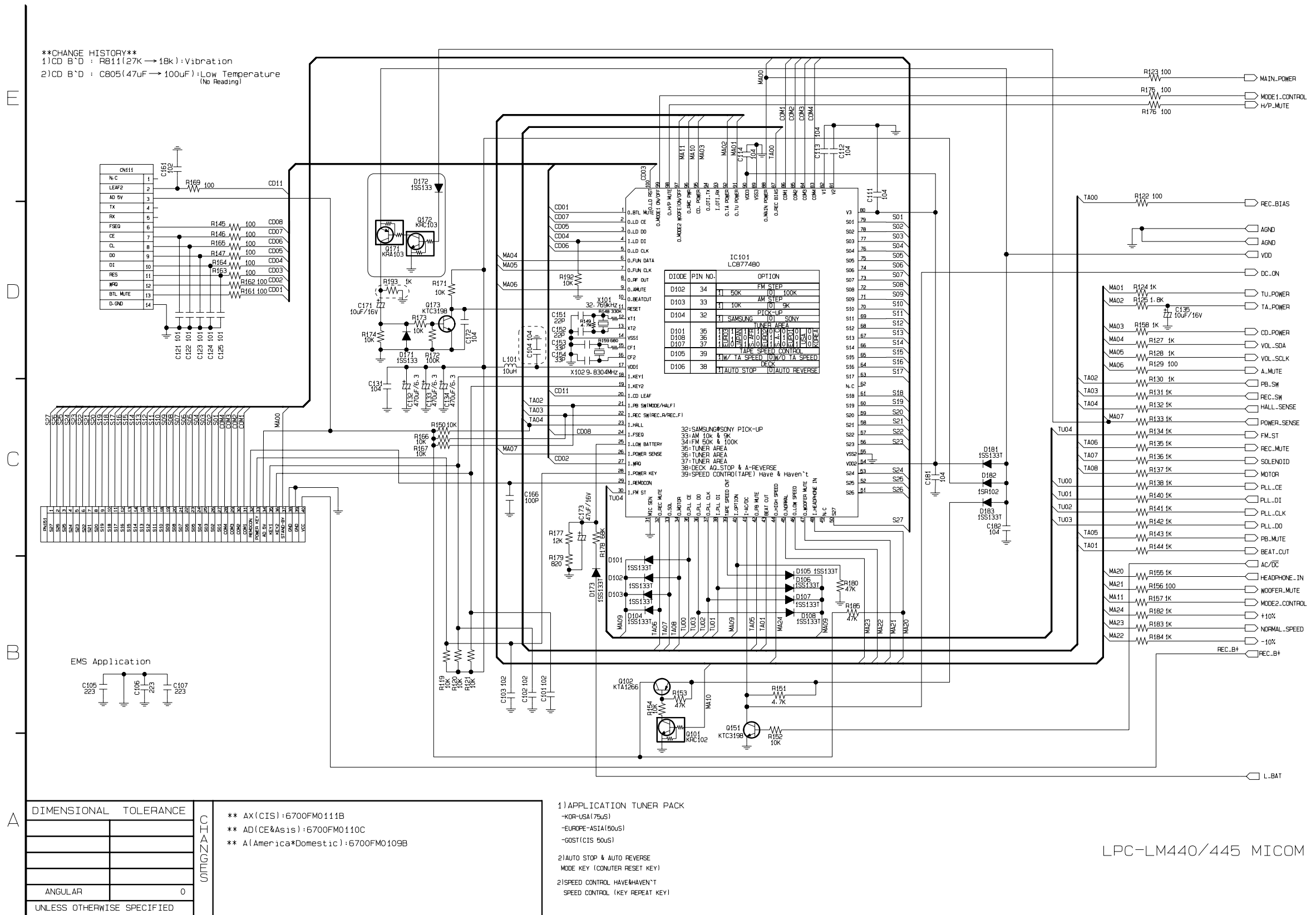

• KEY SCHEMATIC DIAGRAM

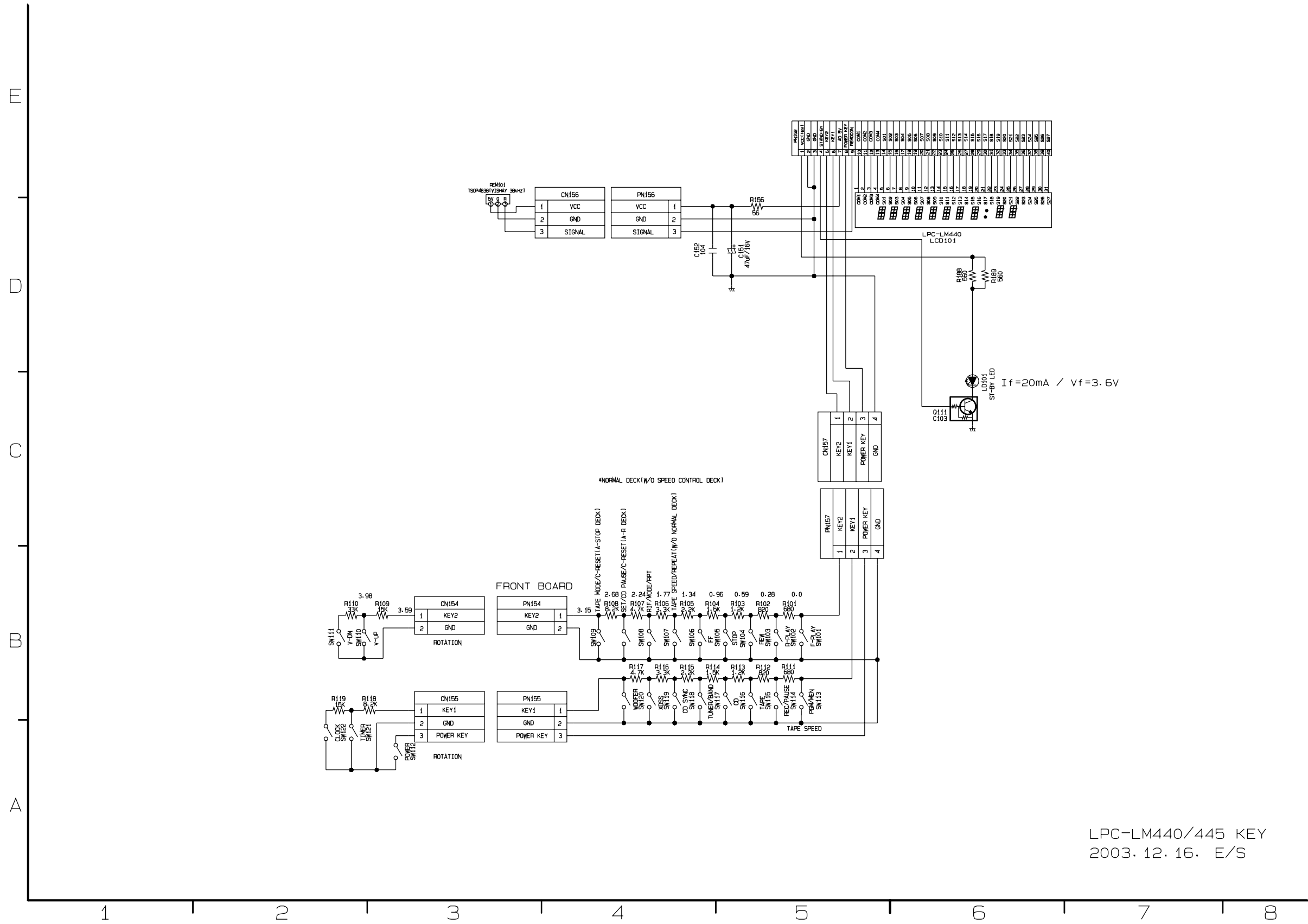

LPC-LM440/445 KEY  
 2003. 12. 16. E/S

• POWER SCHEMATIC DIAGRAM

E  
D  
C  
B  
A

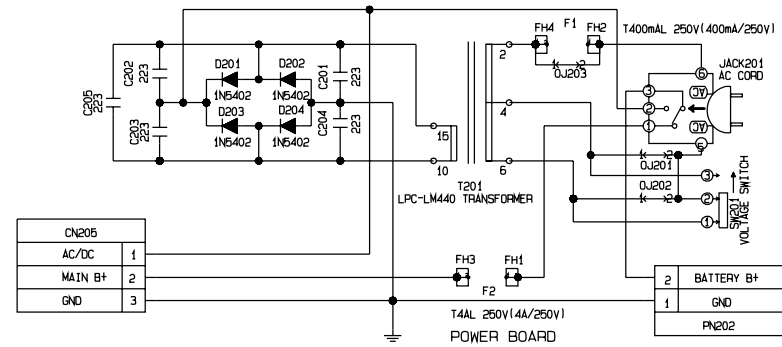

	115V	230	115/230
J201	0	x	x
J202	x	0	x

LPC-LM440/445 POWER  
2003. 12. 16. E/S

1 2 3 4 5 6 7 8



# • DECK SCHEMATIC DIAGRAM

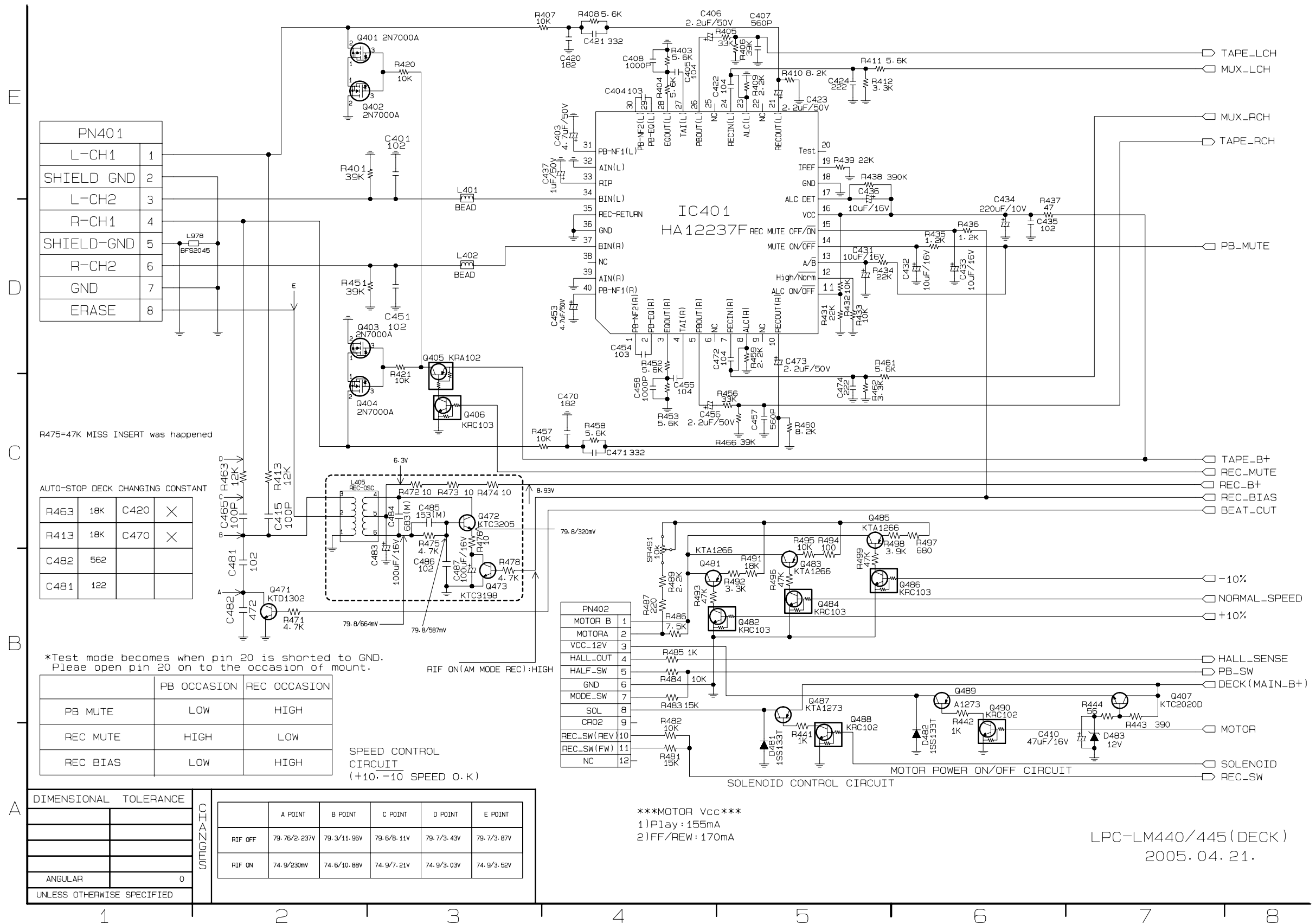









• FRONT P.C. BOARD

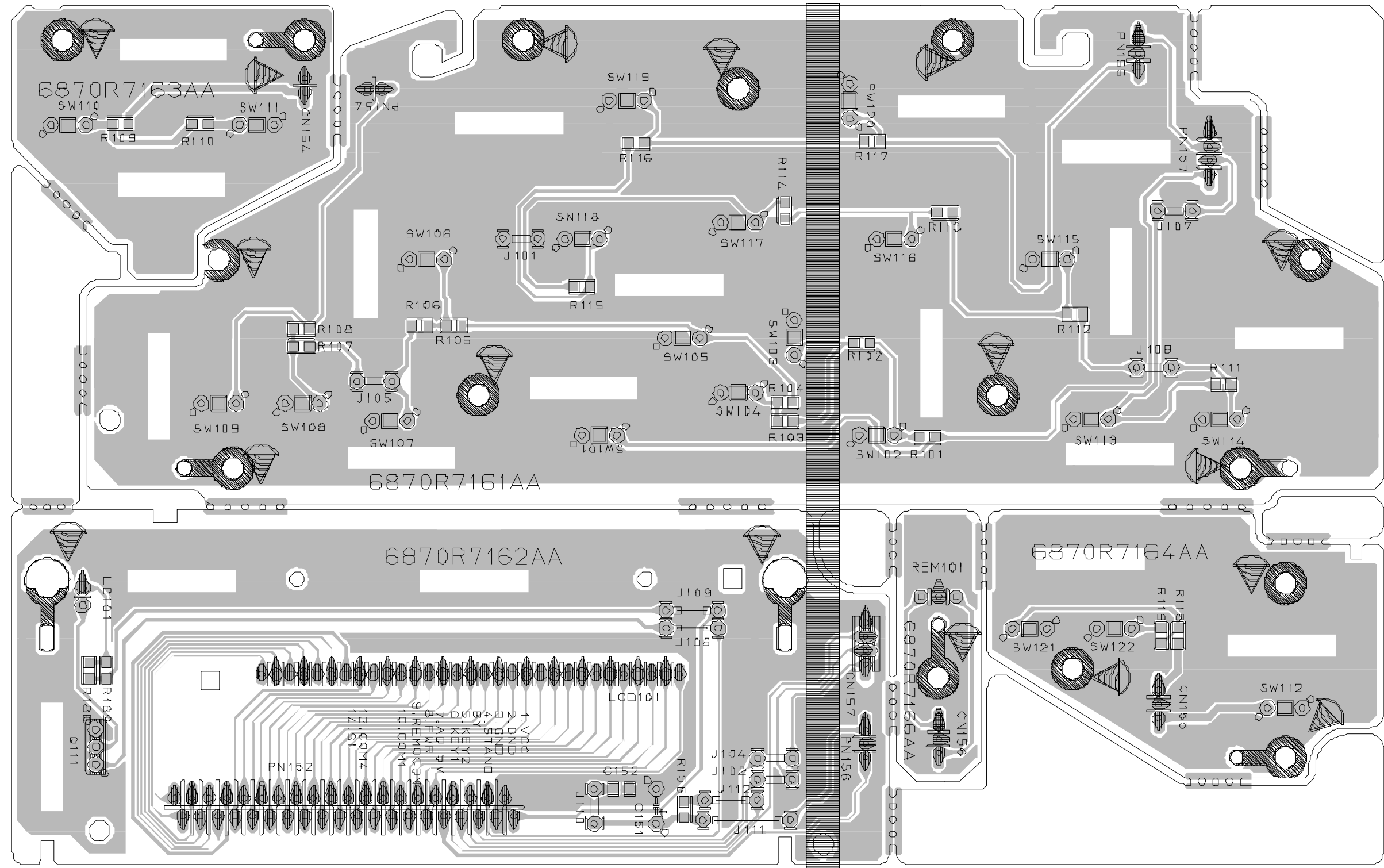

• CDP P.C. BOARD (COMPONENT SIDE)

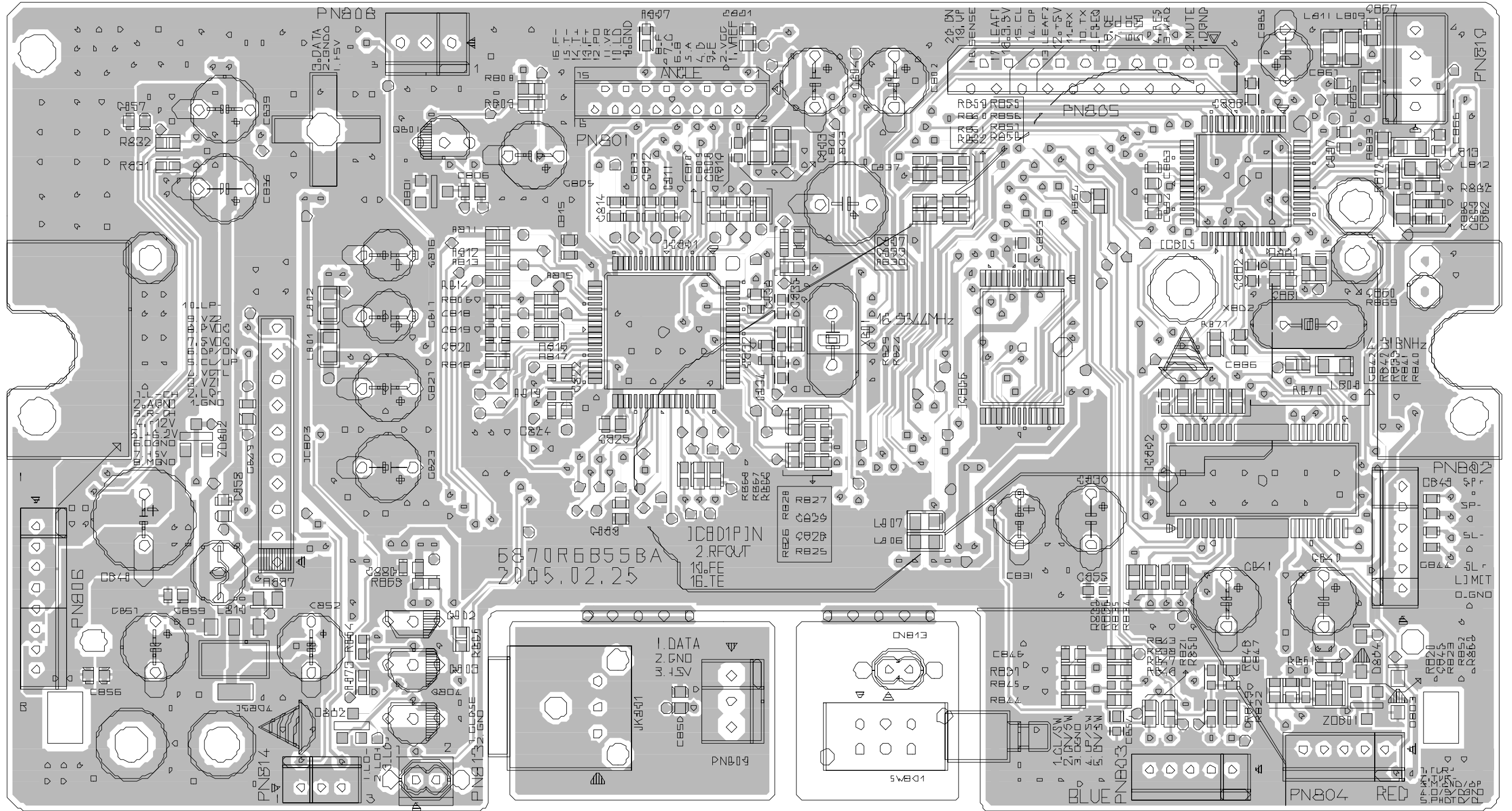



• POWER P.C. BOARD

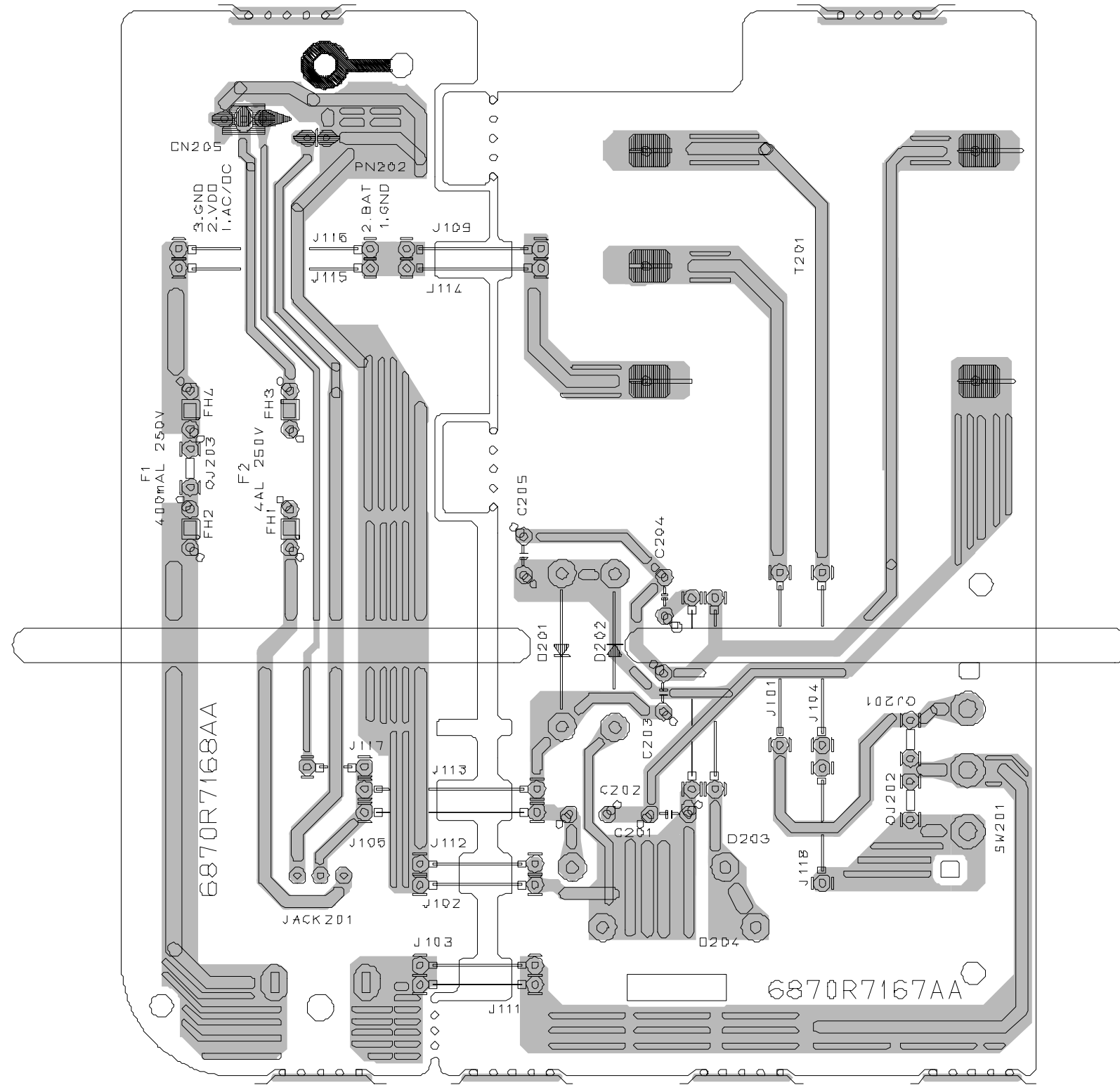



# SECTION 3. EXPLODED VIEWS

NOTE) Refer to SECTION 4 REPLACE-  
MENT PARTS LIST in order to look  
for the part number of each part.

**CAUTION**

Exposed blade will cause severe injury.

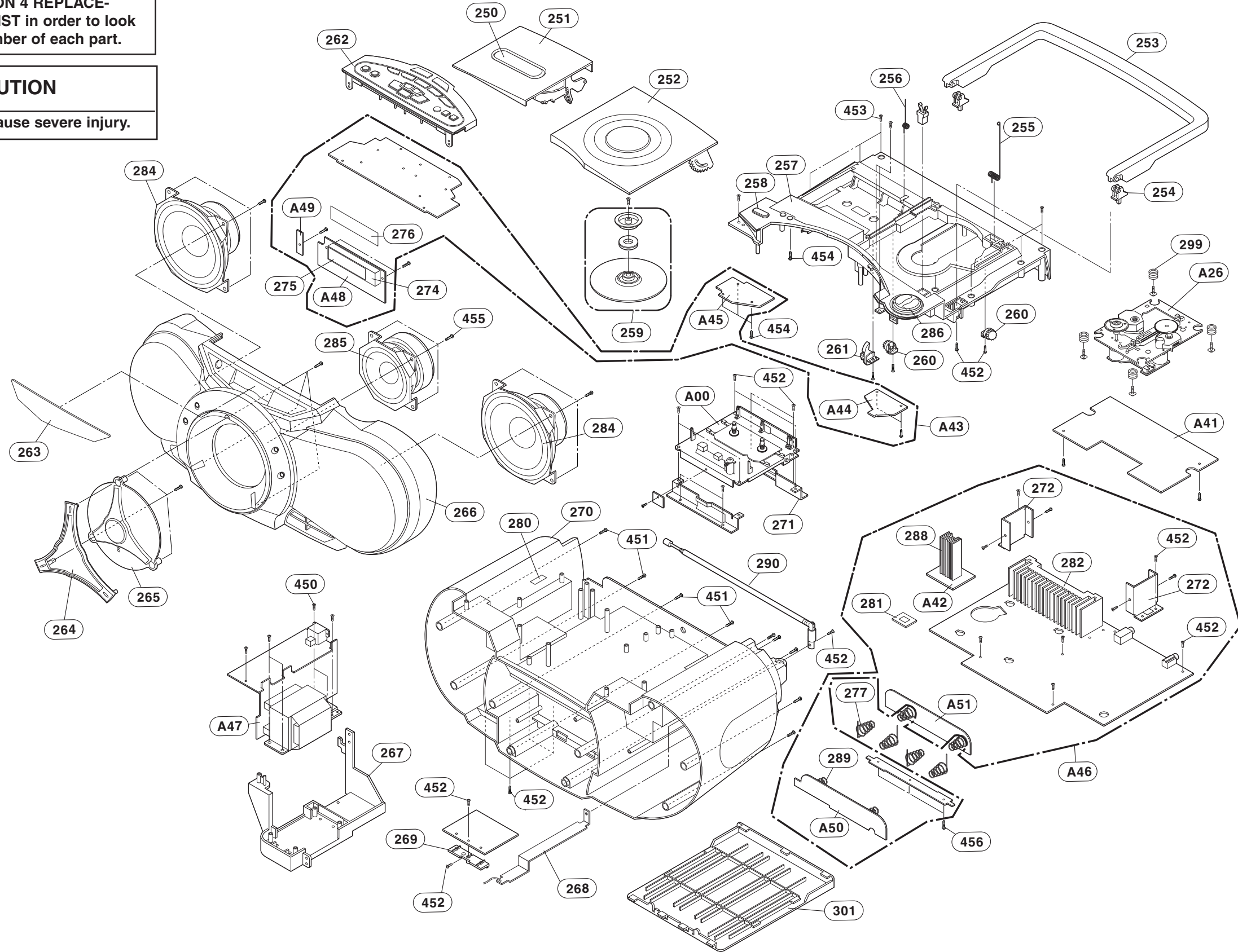

• DECK MECHANISM (LPC-LM440)

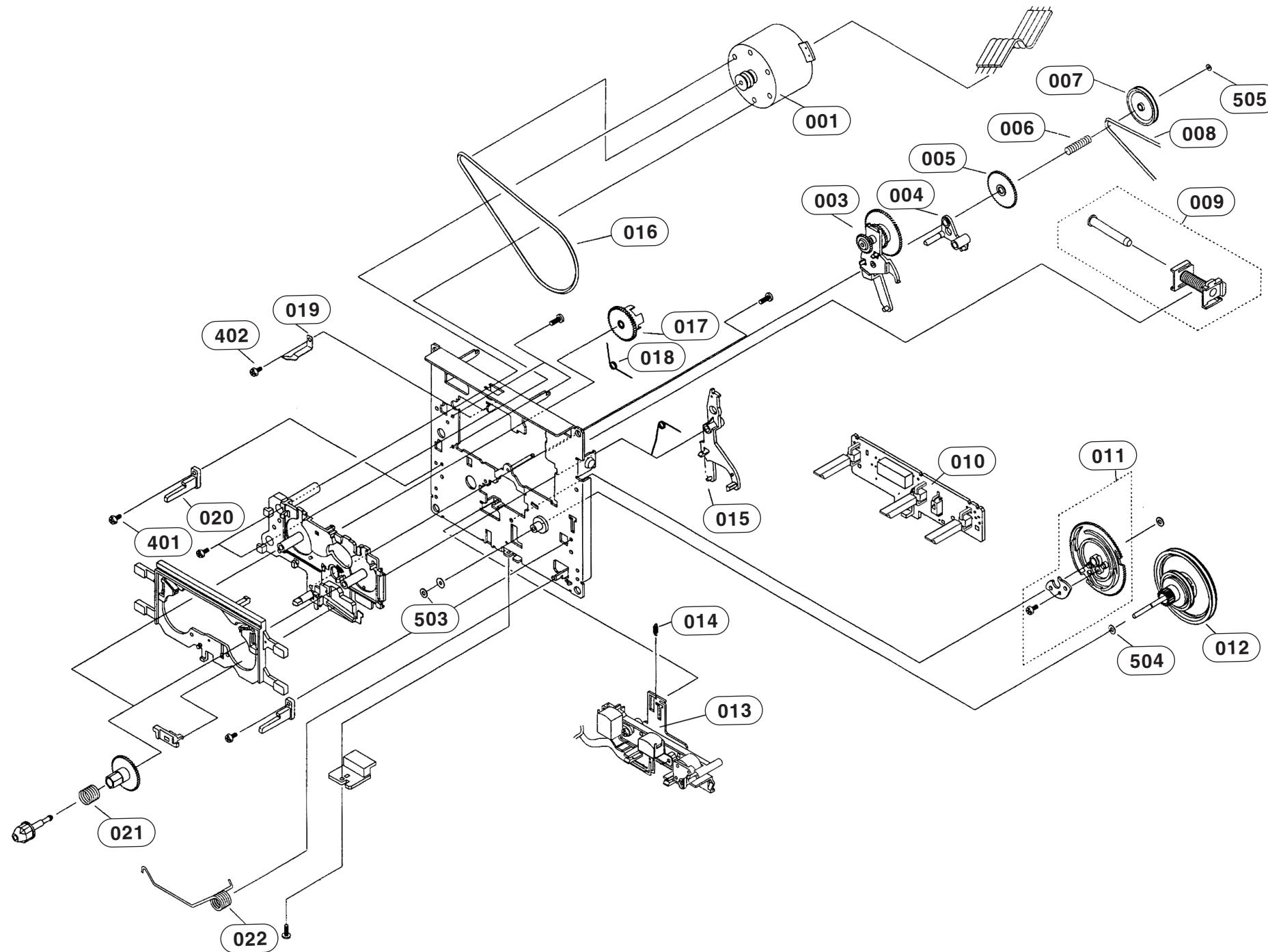

LOCA.NO.	PART NO.	DESCRIPTION	SPECIFICATION
A00	6720AF0013A	DECK,AUDIO	CFM3211 TOKYO PIGEON L-SINGLE
001	6768RZQP01A	DECK MECHANISM PARTS	50-093-41144 PIGEON CST MOTOR(
002	6768R-JP03A	DECK MECHANISM PARTS	50-093-4674 PIGEON PULLEY/FLYW
003	6768RZGP002A	DECK MECHANISM PARTS	50-093-41136 PIGEON GEAR ASSY CLUTCH
004	6768R-AP01C	DECK MECHANISM PARTS	50-239-4072 PIGEON ARM CWL44
005	6768R-GP01J	DECK MECHANISM PARTS	50-222-4428 PIGEON GEAR CRL442
006	6768R-SP01P	DECK MECHANISM PARTS	01-081-4678 PIGEON SPRING CRL4
007	6768R-LP01C	DECK MECHANISM PARTS	50-223-4429 PIGEON PULLEY/FLYW
008	6768R-BP01C	DECK MECHANISM PARTS	02-083-4188 PIGEON BELT/FELT C
009	6768RZVP02A	DECK MECHANISM PARTS	50-093-41073 PIGEON CST SOLENO
010	6768RZXP02A	DECK MECHANISM PARTS	50-093-41076 PIGEON SPECIAL PW
011	6768R-GP03A	DECK MECHANISM PARTS	50-093-4810 PIGEON GEAR ASSY C
012	6768RZJP01A	DECK MECHANISM PARTS	50-093-31032 PIGEON CST PULLEY
013	6768RZHP01A	DECK MECHANISM PARTS	50-093-4960 PIGEON HEAD ASSY C
014	6768R-SP01D	DECK MECHANISM PARTS	01-080-4609 PIGEON SPRING CWL4
015	6768R-AP01A	DECK MECHANISM PARTS	50-268-3016 PIGEON ARM CWL44
016	6768RZBP03A	DECK MECHANISM PARTS	02-083-4268 PIGEON BELT/FELT B
017	6768R-GP03B	DECK MECHANISM PARTS	50-222-4578 PIGEON GEAR IDLER
018	6768R-SP01F	DECK MECHANISM PARTS	01-082-4598 PIGEON SPRING CWL4
019	6768R-PP03A	DECK MECHANISM PARTS	33-160-4309 PIGEON PRESS CASSE
020	6768R-MP01C	DECK MECHANISM PARTS	50-219-4014 PIGEON MOLD CWL44
021	6768R-SP01A	DECK MECHANISM PARTS	01-081-4601 PIGEON SPRING CWL4
022	6768RZSP01A	DECK MECHANISM PARTS	01-082-4688 PIGEON CST SPRING
401	6768R-CP01B	DECK MECHANISM PARTS	GSE20A2005 PIGEON SCREW CWL44
402	6768R-CP01A	DECK MECHANISM PARTS	GSE10A2003 PIGEON SCREW CWL44
501	6768R-WP01F	DECK MECHANISM PARTS	GWN21X040040 PIGEON WASHER CWL
502	6768R-WP03B	DECK MECHANISM PARTS	03-000-4532 PIGEON WASHER CRM4
503	6768R-WP03A	DECK MECHANISM PARTS	GWN19S035040 PIGEON WASHER CRM
504	6768R-WP01D	DECK MECHANISM PARTS	GWP21X045020 PIGEON WASHER CWL
505	6768R-WP01E	DECK MECHANISM PARTS	GWP12X030040S PIGEON WASHER CW

• DECK MECHANISM (LPC-LM445)

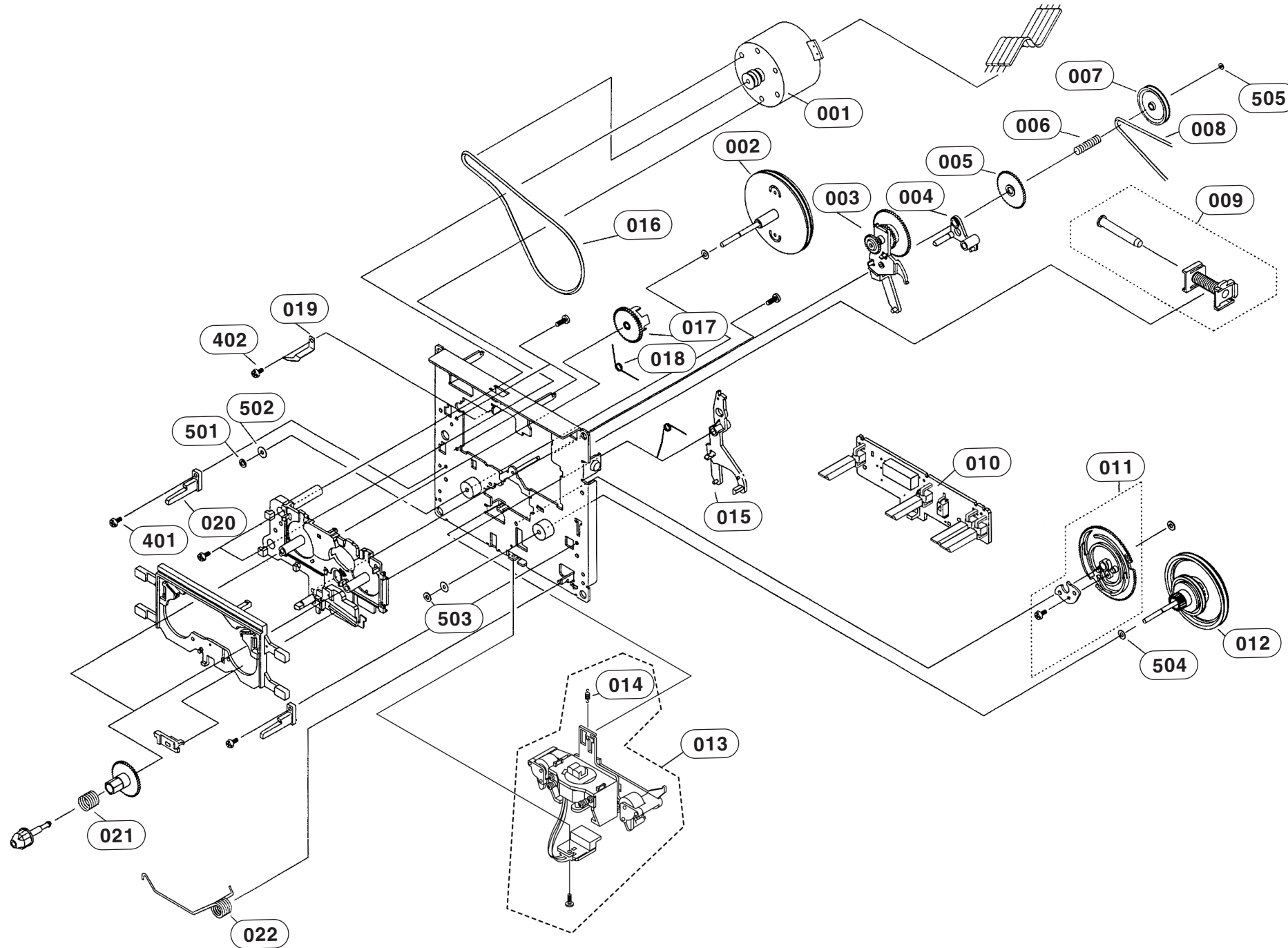

LOCA.NO.	PART NO.	DESCRIPTION	SPECIFICATION
A00	6720AF0014A	DECK,AUDIO	CRM3213 TOKYO PIGEON L-SINGLE
001	6768RZQP01A	DECK MECHANISM PARTS	50-093-41144 PIGEON CST MOTOR
002	6768R-JP03A	DECK MECHANISM PARTS	50-093-4674 PIGEON PULLEY/FLYW
003	6768RZGP002A	DECK MECHANISM PARTS	50-093-41136 PIGEON GEAR ASSY CLUTCH
004	6768R-AP01C	DECK MECHANISM PARTS	50-239-4072 PIGEON ARM CWL44
005	6768R-GP01J	DECK MECHANISM PARTS	50-222-4428 PIGEON GEAR CRL442
006	6768R-SP01P	DECK MECHANISM PARTS	01-081-4678 PIGEON SPRING CRL4
007	6768R-LP01C	DECK MECHANISM PARTS	50-223-4429 PIGEON PULLEY/FLYW
008	6768R-BP01C	DECK MECHANISM PARTS	02-083-4188 PIGEON BELT/FELT C
009	6768RZVP02A	DECK MECHANISM PARTS	50-093-41073 PIGEON CST SOLENO
010	6768RZXP01A	DECK MECHANISM PARTS	50-093-41073 PIGEON CST SPECIA
011	6768R-GP03A	DECK MECHANISM PARTS	50-093-4810 PIGEON GEAR ASSY C
012	6768RZJP01A	DECK MECHANISM PARTS	50-093-31032 PIGEON CST PULLEY
013	6768RZEP05A	DECK MECHANISM PARTS	50-093-4809 PIGEON CST HEAD AS
014	6768R-SP01D	DECK MECHANISM PARTS	01-080-4609 PIGEON SPRING CWL4
015	6768R-AP01A	DECK MECHANISM PARTS	50-268-3016 PIGEON ARM CWL44
016	6768RZBP02A	DECK MECHANISM PARTS	02-083-4267 PIGEON CST BELT/FE
017	6768R-GP03B	DECK MECHANISM PARTS	50-222-4578 PIGEON GEAR IDLER
018	6768R-SP01F	DECK MECHANISM PARTS	01-082-4598 PIGEON SPRING CWL4
019	6768R-PP03A	DECK MECHANISM PARTS	33-160-4309 PIGEON PRESS CASSE
020	6768R-MP01C	DECK MECHANISM PARTS	50-219-4014 PIGEON MOLD CWL44
021	6768R-SP01A	DECK MECHANISM PARTS	01-081-4601 PIGEON SPRING CWL4
022	6768RZSP01A	DECK MECHANISM PARTS	01-082-4688 PIGEON CST SPRING
401	6768R-CP01B	DECK MECHANISM PARTS	GSE20A2005 PIGEON SCREW CWL44
402	6768R-CP01A	DECK MECHANISM PARTS	GSE10A2003 PIGEON SCREW CWL44
501	6768R-WP01F	DECK MECHANISM PARTS	GWN21X040040 PIGEON WASHER CWL
502	6768R-WP03B	DECK MECHANISM PARTS	03-000-4532 PIGEON WASHER CRM4
503	6768R-WP03A	DECK MECHANISM PARTS	GWN19S035040 PIGEON WASHER CRM
504	6768R-WP01D	DECK MECHANISM PARTS	GWP21X045020 PIGEON WASHER CWL
505	6768R-WP01E	DECK MECHANISM PARTS	GWP12X030040S PIGEON WASHER CW