

[CONTENTS]

○ SECTION 1. GENERAL

- SERVICING PRECAUTIONS 1-2
- ESD PRECAUTIONS 1-4
- SPECIFICATION 1-5

○ SECTION 2. ELECTRICAL SECTION

- ADJUSTMENTS 2-1
- AUDIO PART ELECTRICAL TROUBLESHOOTING GUIDE 2-2
- BLOCK DIAGRAM 2-11
- SCHEMATIC DIAGRAMS 2-13
- IC/TR VOLTAGE SHEET 2-19
- WIREING DIAGRAM 2-21
- PRINTED CIRCUIT DIAGRAMS 2-23

○ SECTION 3. DVD PART ELECTRICAL TROUBLESHOOTING GUIDE

- TROUBLESHOOTING 3-1
- DETAILS AND WAVEFORMS ON SYSTEM TEST AND DEBUGGING 3-8
- DVD PART SCHEMATIC DIAGRAMS 3-21
- PRINTED CIRCUIT DIAGRAM 3-29

○ SECTION 4. EXPLODED VIEWS

- CABINET AND MAIN FRAME SECTION 4-1

○ SECTION 5. SPEAKER PART

- SPEAKER PART 5-1

○ SECTION 6. REPLACEMENT PARTS LIST

- REPLACEMENT PARTS LIST 6-1

SECTION 1. GENERAL

□ SERVICING PRECAUTIONS

NOTES REGARDING HANDLING OF THE PICK-UP

1. Notes for transport and storage

- 1) The pick-up should always be left in its conductive bag until immediately prior to use.
- 2) The pick-up should never be subjected to external pressure or impact.

Storage in conductive bag

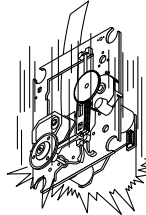
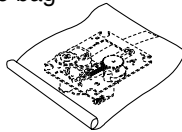

Drop impact

2. Repair notes

- 1) The pick-up incorporates a strong magnet, and so should never be brought close to magnetic materials.
- 2) The pick-up should always be handled correctly and carefully, taking care to avoid external pressure and impact. If it is subjected to strong pressure or impact, the result may be an operational malfunction and/or damage to the printed-circuit board.
- 3) Each and every pick-up is already individually adjusted to a high degree of precision, and for that reason the adjustment point and installation screws should absolutely never be touched.
- 4) Laser beams may damage the eyes!
Absolutely never permit laser beams to enter the eyes!
Also NEVER switch ON the power to the laser output part (lens, etc.) of the pick-up if it is damaged.

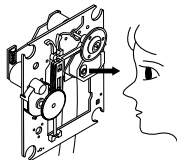

NEVER look directly at the laser beam, and don't let contact fingers or other exposed skin.

5) Cleaning the lens surface

If there is dust on the lens surface, the dust should be cleaned away by using an air bush (such as used for camera lens). The lens is held by a delicate spring. When cleaning the lens surface, therefore, a cotton swab should be used, taking care not to distort this.

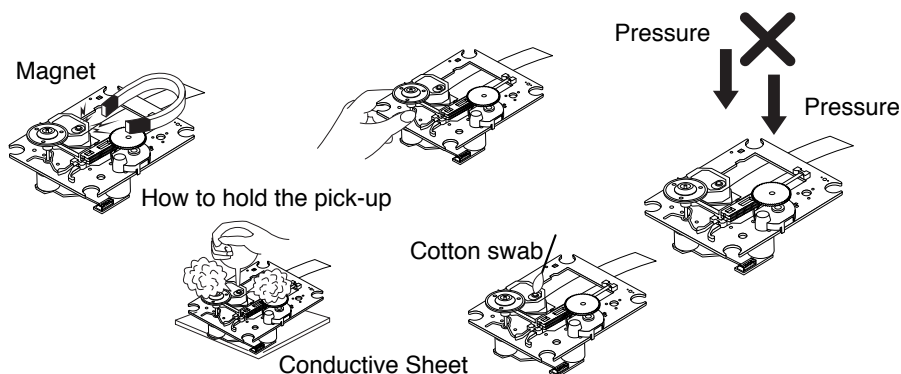

6) Never attempt to disassemble the pick-up.

Spring by excess pressure. If the lens is extremely dirty, apply isopropyl alcohol to the cotton swab. (Do not use any other liquid cleaners, because they will damage the lens.) Take care not to use too much of this alcohol on the swab, and do not allow the alcohol to get inside the pick-up.

NOTES REGARDING COMPACT DISC PLAYER REPAIRS

1. Preparations

- 1) Compact disc players incorporate a great many ICs as well as the pick-up (laser diode). These components are sensitive to, and easily affected by, static electricity. If such static electricity is high voltage, components can be damaged, and for that reason components should be handled with care.
- 2) The pick-up is composed of many optical components and other high-precision components. Care must be taken, therefore, to avoid repair or storage where the temperature of humidity is high, where strong magnetism is present, or where there is excessive dust.

2. Notes for repair

- 1) Before replacing a component part, first disconnect the power supply lead wire from the unit
- 2) All equipment, measuring instruments and tools must be grounded.
- 3) The workbench should be covered with a conductive sheet and grounded.
When removing the laser pick-up from its conductive bag, do not place the pick-up on the bag. (This is because there is the possibility of damage by static electricity.)
- 4) To prevent AC leakage, the metal part of the soldering iron should be grounded.
- 5) Workers should be grounded by an armband (1M Ω)
- 6) Care should be taken not to permit the laser pick-up to come in contact with clothing, in order to prevent static electricity changes in the clothing to escape from the armband.
- 7) The laser beam from the pick-up should NEVER be directly facing the eyes or bare skin.

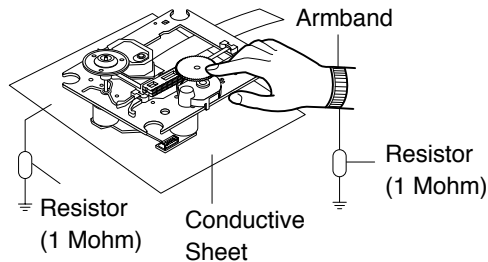

CLEARING MALFUNCTION

You can reset your unit to initial status if malfunction occur(button malfunction, display, etc.).

Using a pointed good conductor(such as driver), simply short the RESET jump wire on the inside of the volume knob for more than 3 seconds.

If you reset your unit, you must reenter all its settings(stations, clock, timer)

- NOTE:** 1. To operate the RESET jump wire, pull the volume rotary knob and release it.
2. If you wish to operate the RESET jump wire, it is necessary to unplug the power cord.

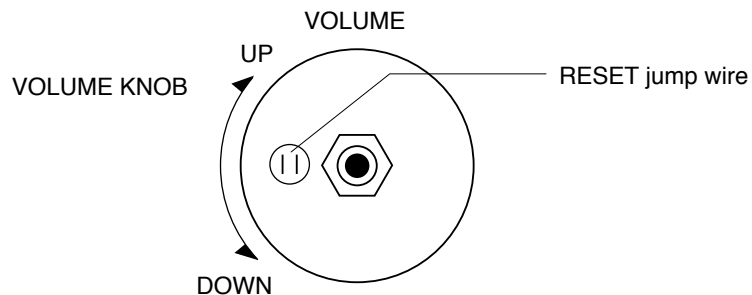

□ ESD PRECAUTIONS

Electrostatically Sensitive Devices (ESD)



Some semiconductor (solid state) devices can be damaged easily by static electricity. Such components commonly are called Electrostatically Sensitive Devices (ESD). Examples of typical ESD devices are integrated circuits and some field-effect transistors and semiconductor chip components. The following techniques should be used to help reduce the incidence of component damage caused by static electricity.

1. Immediately before handling any semiconductor component or semiconductor-equipped assembly, drain off any electrostatic charge on your body by touching a known earth ground. Alternatively, obtain and wear a commercially available discharging wrist strap device, which should be removed for potential shock reasons prior to applying power to the unit under test.
2. After removing an electrical assembly equipped with ESD devices, place the assembly on a conductive surface such as aluminum foil, to prevent electrostatic charge buildup or exposure of the assembly.
3. Use only a grounded-tip soldering iron to solder or unsolder ESD devices.
4. Use only an anti-static solder removal device. Some solder removal devices not classified as "anti-static" can generate electrical charges sufficient to damage ESD devices.
5. Do not use freon-propelled chemicals. These can generate electrical charges sufficient to damage ESD devices.
6. Do not remove a replacement ESD device from its protective package until immediately before you are ready to install it. (Most replacement ESD devices are packaged with leads electrically shorted together by conductive foam, aluminum foil or comparable conductive materials).
7. Immediately before removing the protective material from the leads of a replacement ESD device, touch the protective material to the chassis or circuit assembly into which the device will be installed.

CAUTION : BE SURE NO POWER IS APPLIED TO THE CHASSIS OR CIRCUIT, AND OBSERVE ALL OTHER SAFETY PRECAUTIONS.

8. Minimize bodily motions when handling unpackaged replacement ESD devices. (Otherwise harmless motion such as the brushing together of your clothes fabric or the lifting of your foot from a carpeted floor can generate static electricity sufficient to damage an ESD device).

[CAUTION. GRAPHIC SYMBOLS]

	THE LIGHTNING FLASH WITH APROWHEAD SYMBOL. WITHIN AN EQUILATERAL TRIANGLE, IS INTENDED TO ALERT THE SERVICE PERSONNEL TO THE PRESENCE OF UNINSULATED "DANGEROUS VOLTAGE" THAT MAY BE OF SUFFICIENT MAGNITUDE TO CONSTITUTE A RISK OF ELECTRIC SHOCK.
	THE EXCLAMATION POINT WITHIN AN EQUILATERAL TRIANGLE IS INTENDED TO ALERT THE SERVICE PERSONNEL TO THE PRESENCE OF IMPORTANT SAFETY INFORMATION IN SERVICE LITERATURE.

SECTION 2. ELECTRICAL SECTION

ADJUSTMENTS

This set has been aligned at the factory and normally will not require further adjustment. As a result, it is not recommended that any attempt is made to modify any circuit. If any parts are replaced or if anyone tampers with the adjustment, realignment may be necessary.

IMPORTANT

1. Check Power-source voltage.
2. Set the function switch to band being aligned.
3. Turn volume control to minimum unless otherwise noted.
4. Connect low side of signal source and output indicator to chassis ground unless otherwise specified.
5. Keep the signal input as low as possible to avoid AGC and AC action.

TAPE DECK ADJUSTMENT

1. AZIMUTH ADJUSTMENT

Deck Mode	Test Tape	Test Point	Adjustment	Adjust for
Palyback	MTT-114	Speaker Out	DECK Screw Azimuth Screw	Maximum

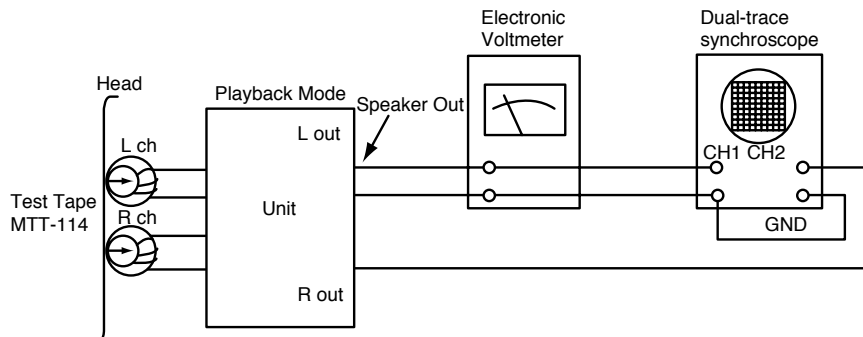
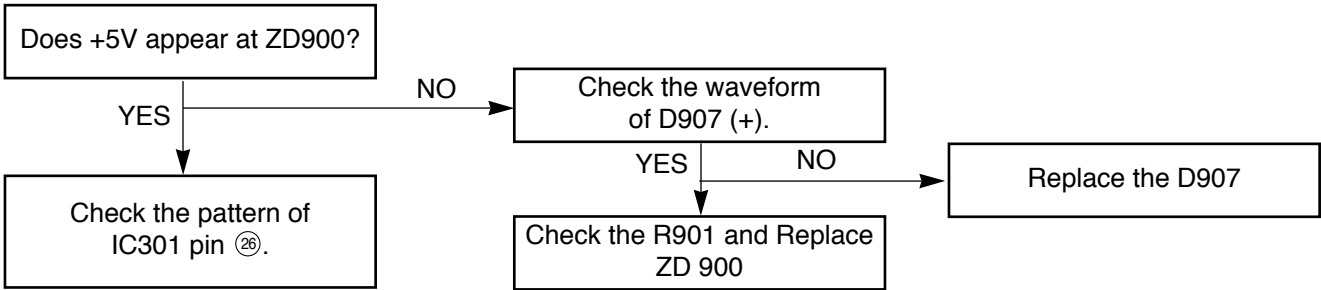

Figure 1. Azimuth Adjustment Connection Diagram

□ AUDIO PART ELECTRICAL TROUBLESHOOTING GUIDE

P-SENS PART



VKK PART

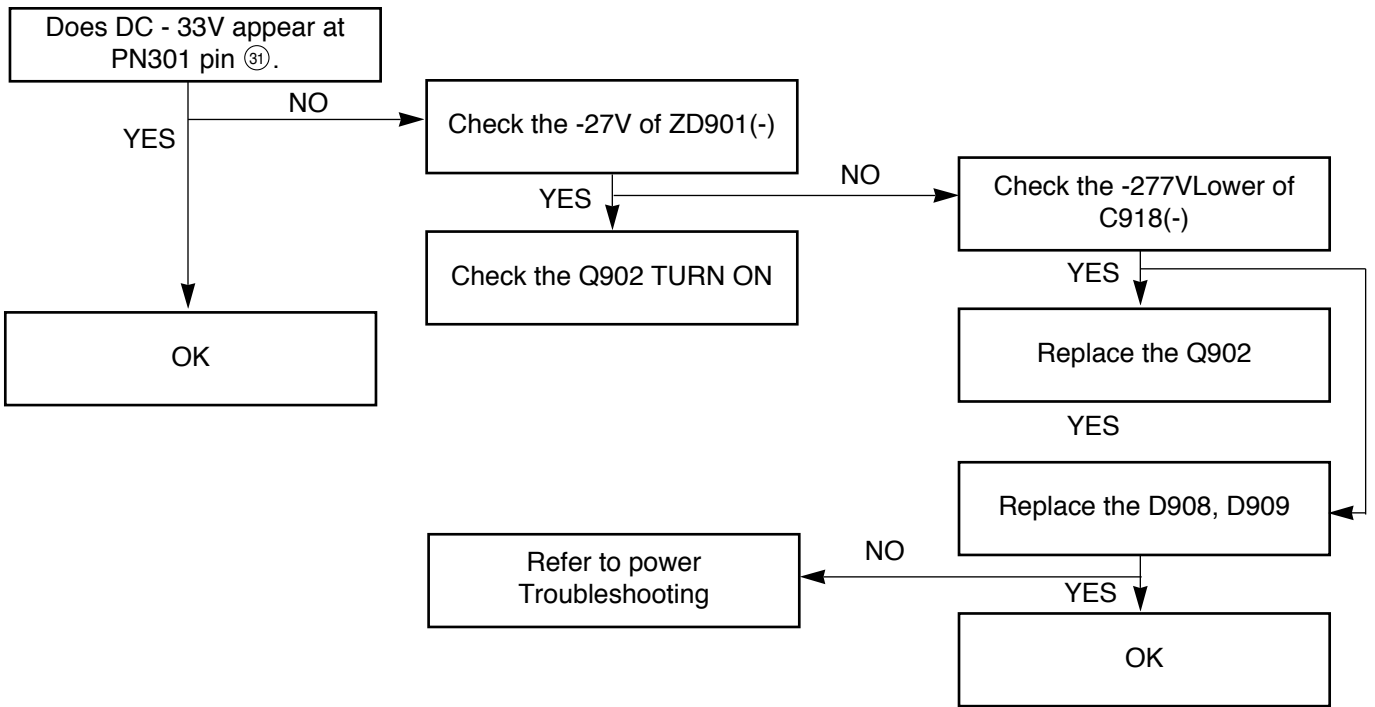

POWER CIRCUIT

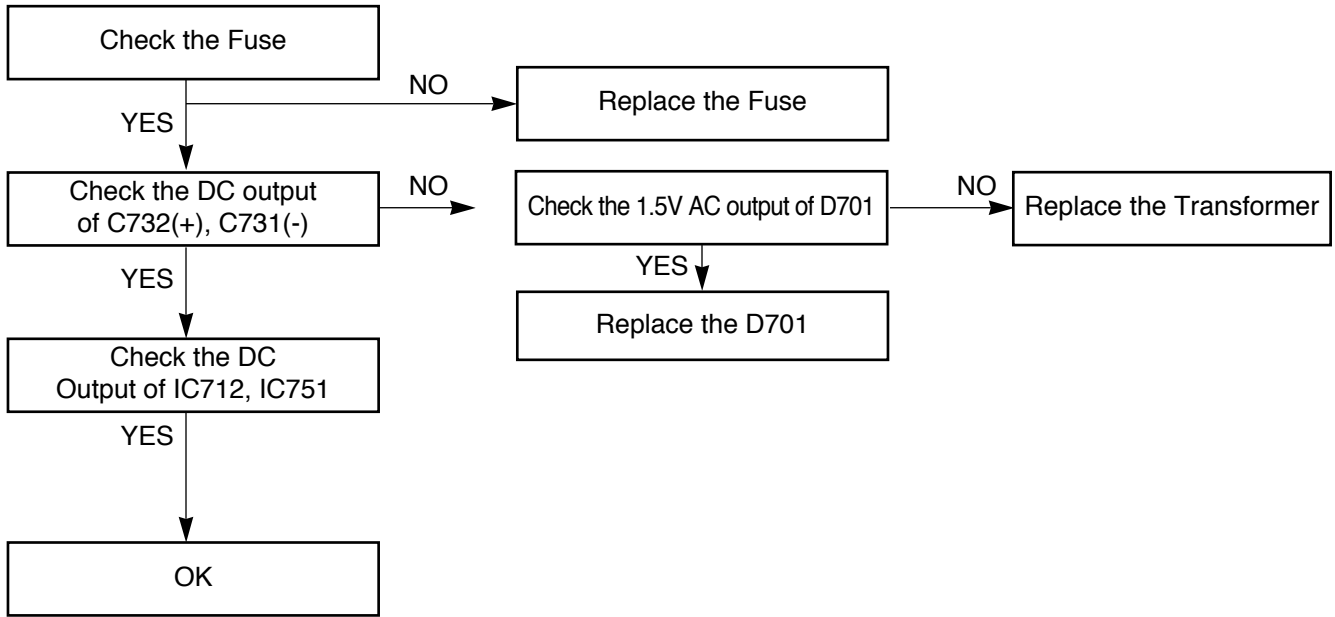

MUTING CIRCUIT (MUTE)

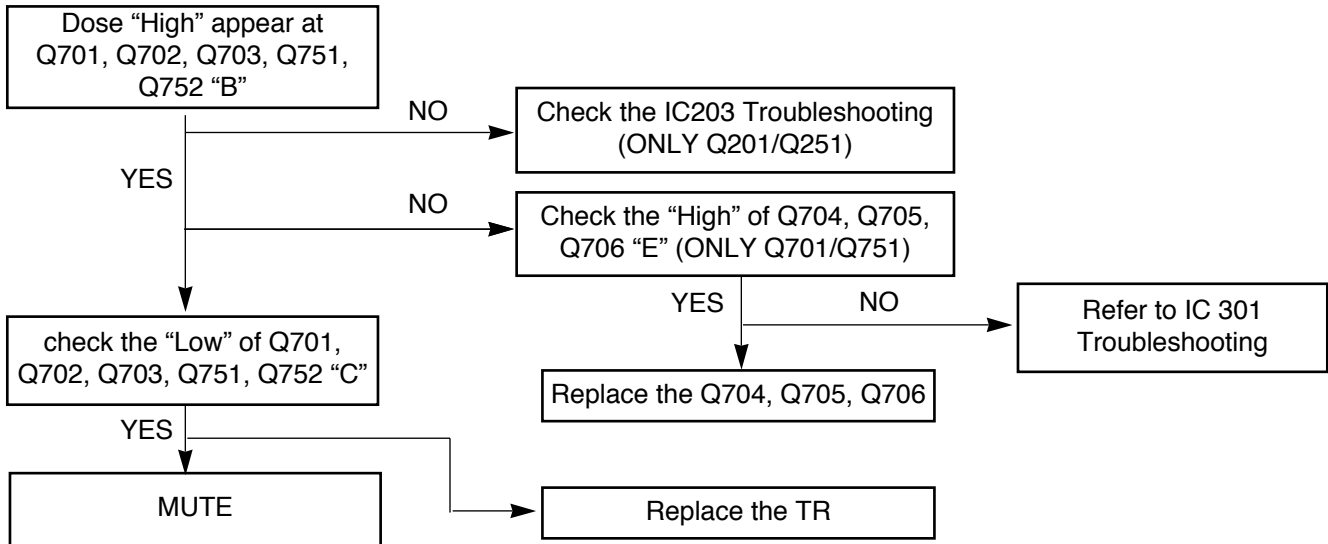

AUDIO ABNORMAL

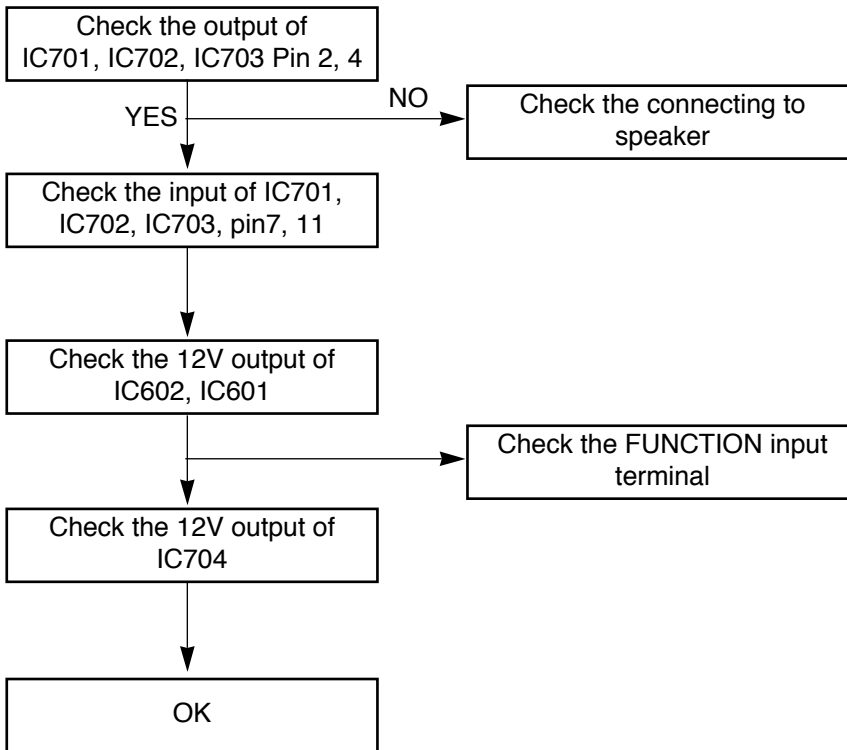

FUNCTION MODE AUDIO ABNORMAL

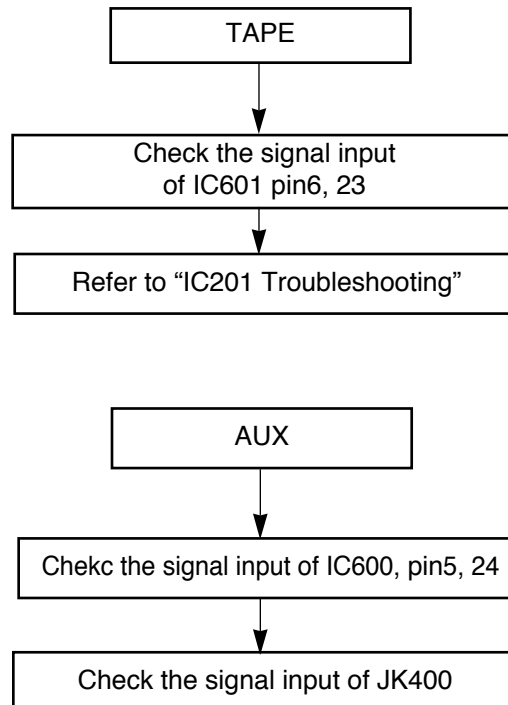

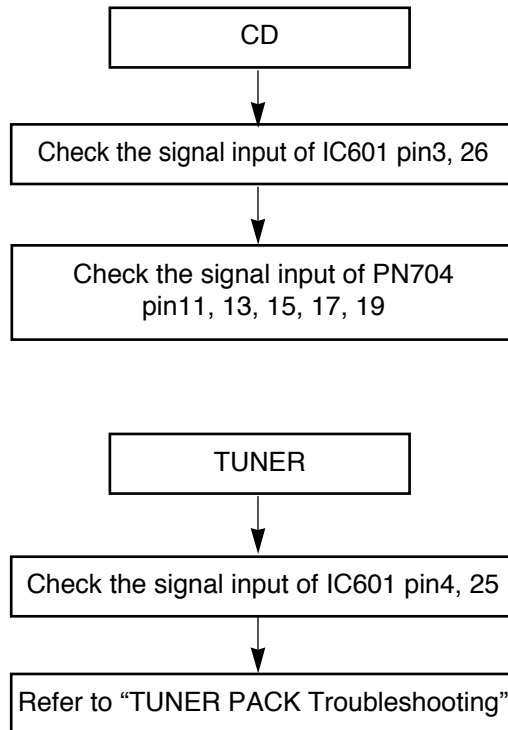

IC301 TROUBLESHOOTING

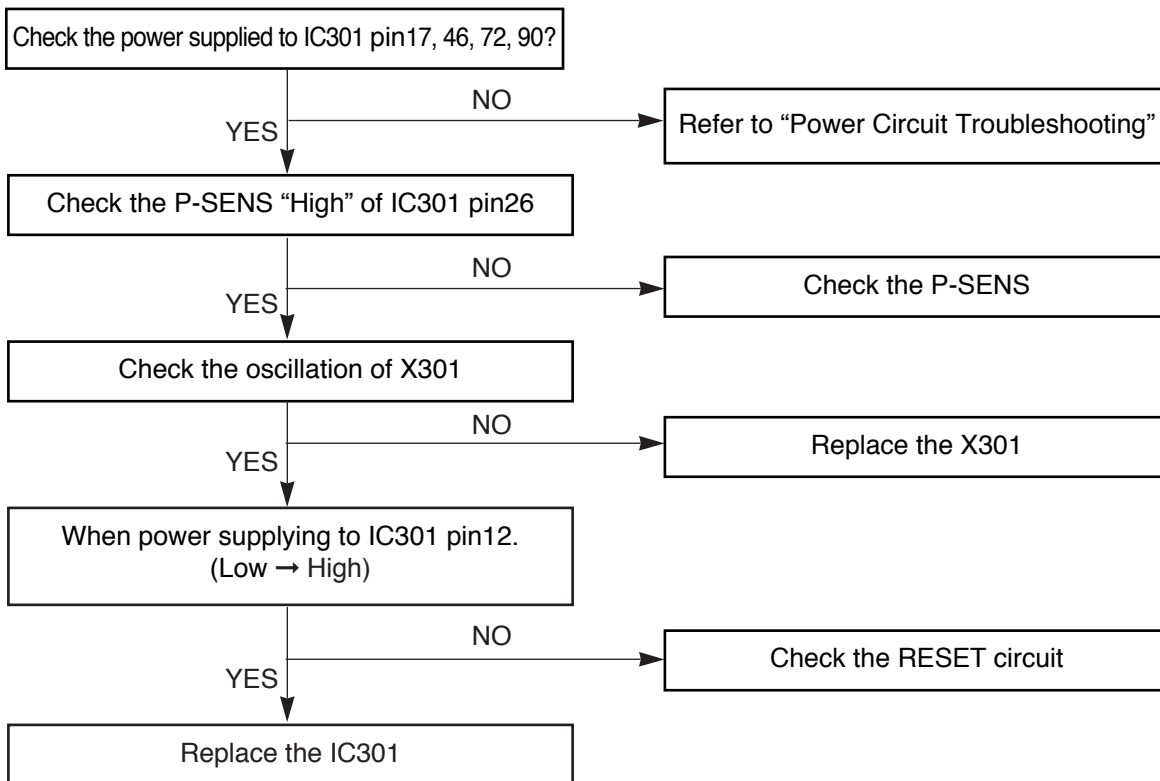

IC601 TROUBLESHOOTING

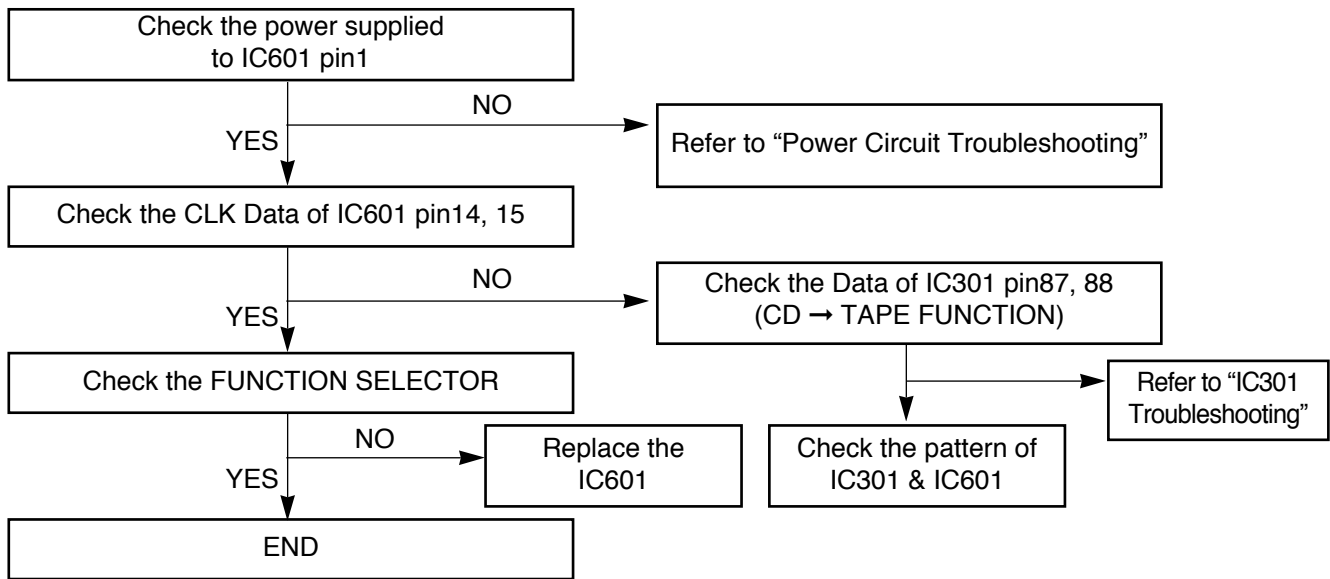

IC602 TROUBLESHOOTING

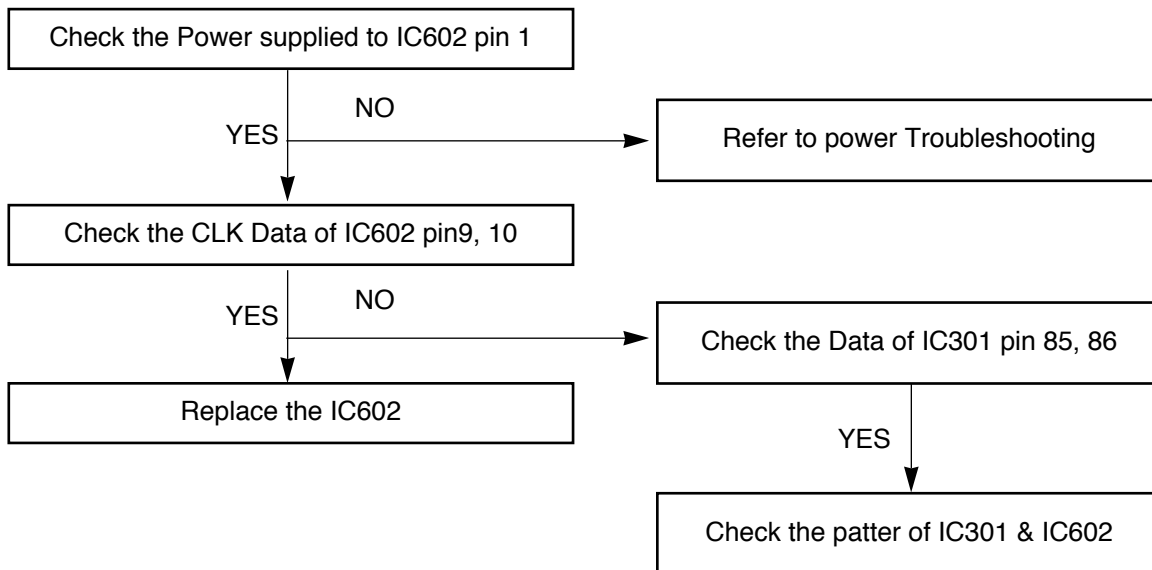

TUNER PACK TROUBLESHOOTING

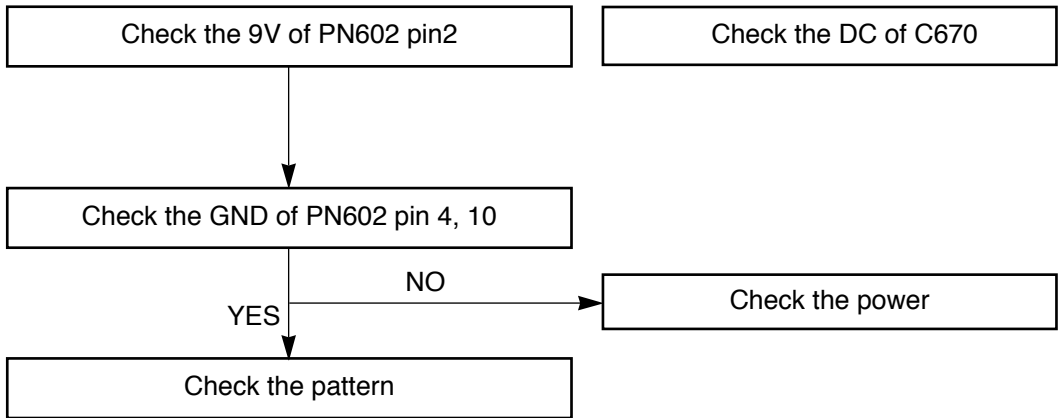

PLAY

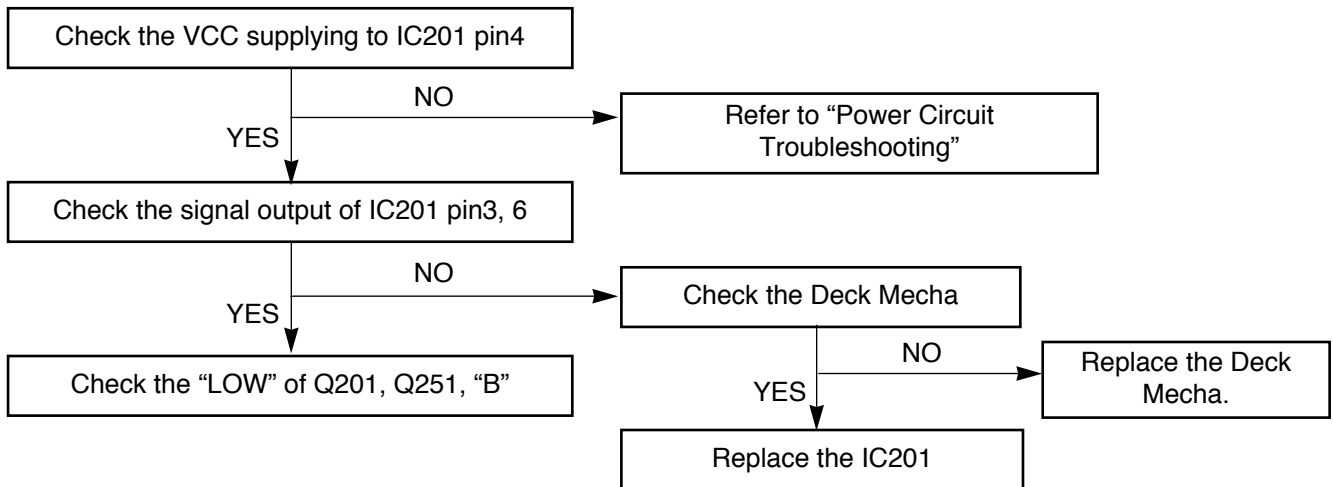

REC (Q252, Q202 ON / R273, R223 HIGH)

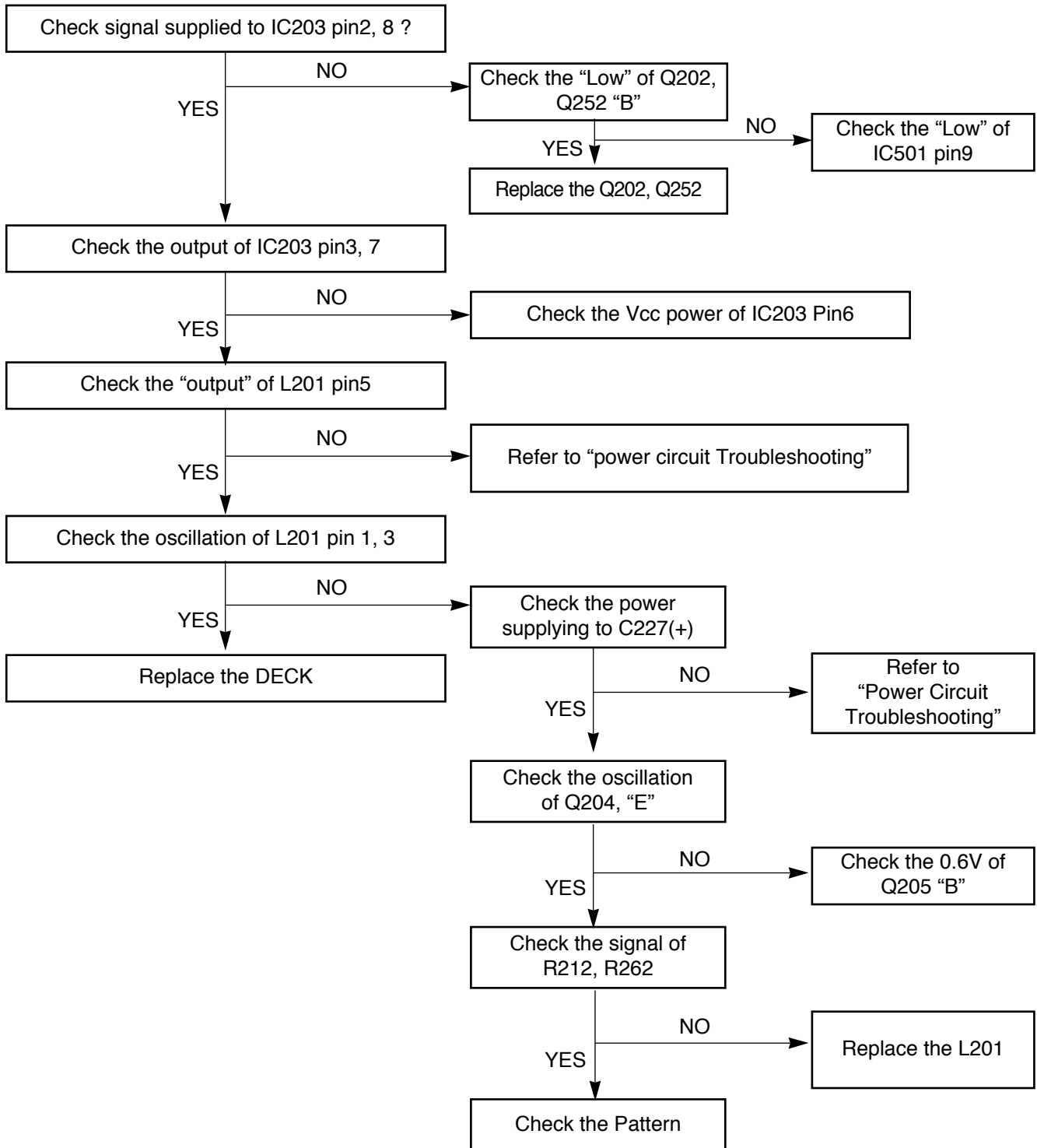

• POWER P.C. BOARD (SOLDER SIDE)

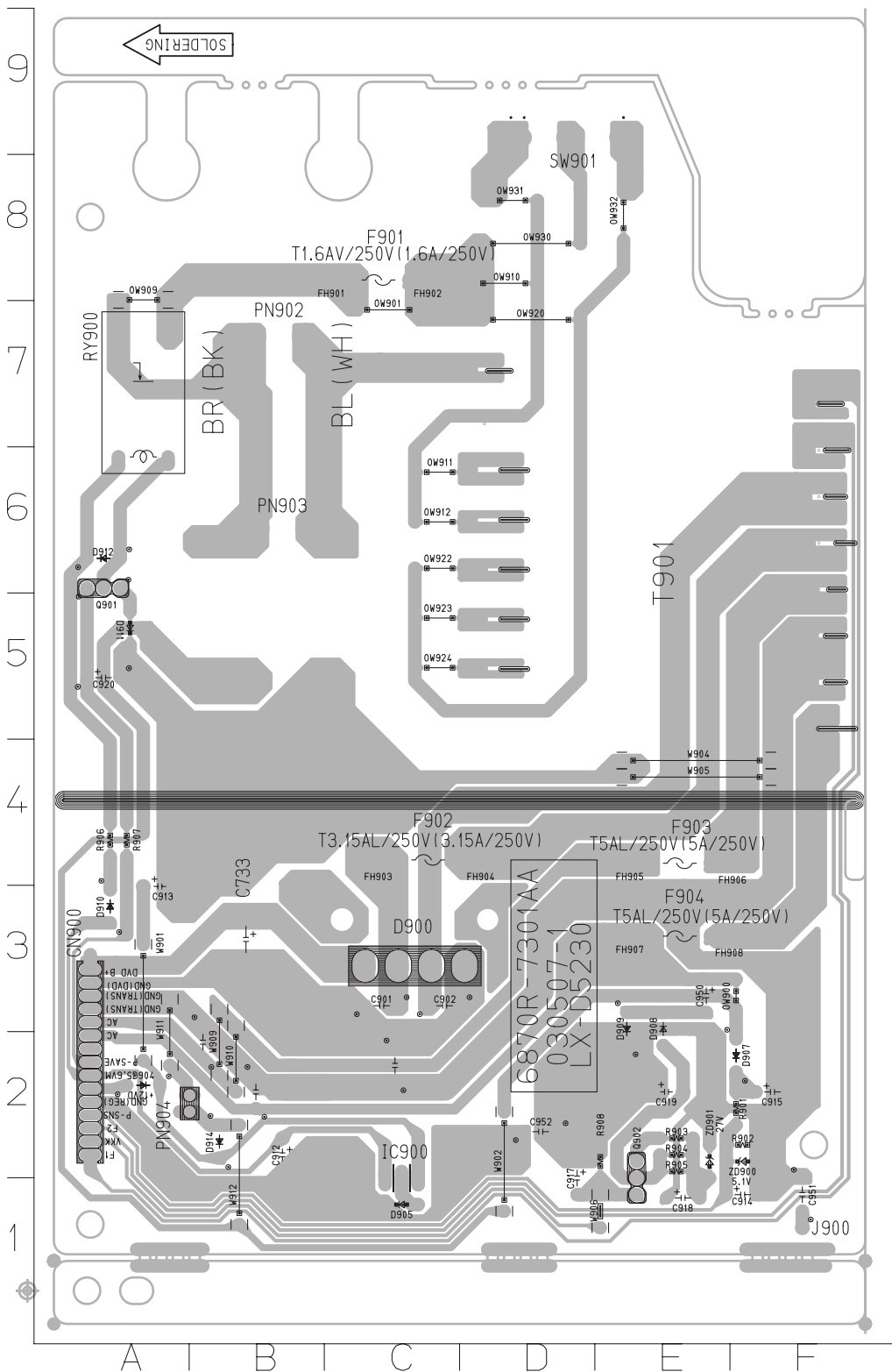

C901	C3
C902	C3
C912	B2
C913	A3
C914	F1
C917	D1
C918	E1
C919	E2
C920	A5
C950	E3
C951	F1
C952	D2
D904	A2
D905	C1
D907	F2
D908	E3
D909	E3
D910	A3
D911	A5
D912	A6
D914	B2
D915	F2
FH901	C8
FH902	C8
FH903	C4
FH904	D4
FH905	E4
FH906	E4
FH907	E3
FH908	E3
IC900	C1
OW900	F3
OW901	C7
OW909	A8
OW910	D8
OW911	C6
OW912	C6
OW920	D7
OW922	C6
OW923	C5
OW924	C5
OW930	D8
OW931	D8
OW932	E8
PN902	B7
PN903	B6
PN904	B2
Q901	A6
Q902	E1
R901	F2
R902	F2
R903	E2
R904	E2
R905	E2
R906	A4
R907	A4
R908	E2
RY900	A7
SW901	D9
T601	E6
ZD900	F2
ZD901	E2

SECTION 3. DVD PART ELECTRICAL TROUBLESHOOTING GUIDE

1. Power check flow

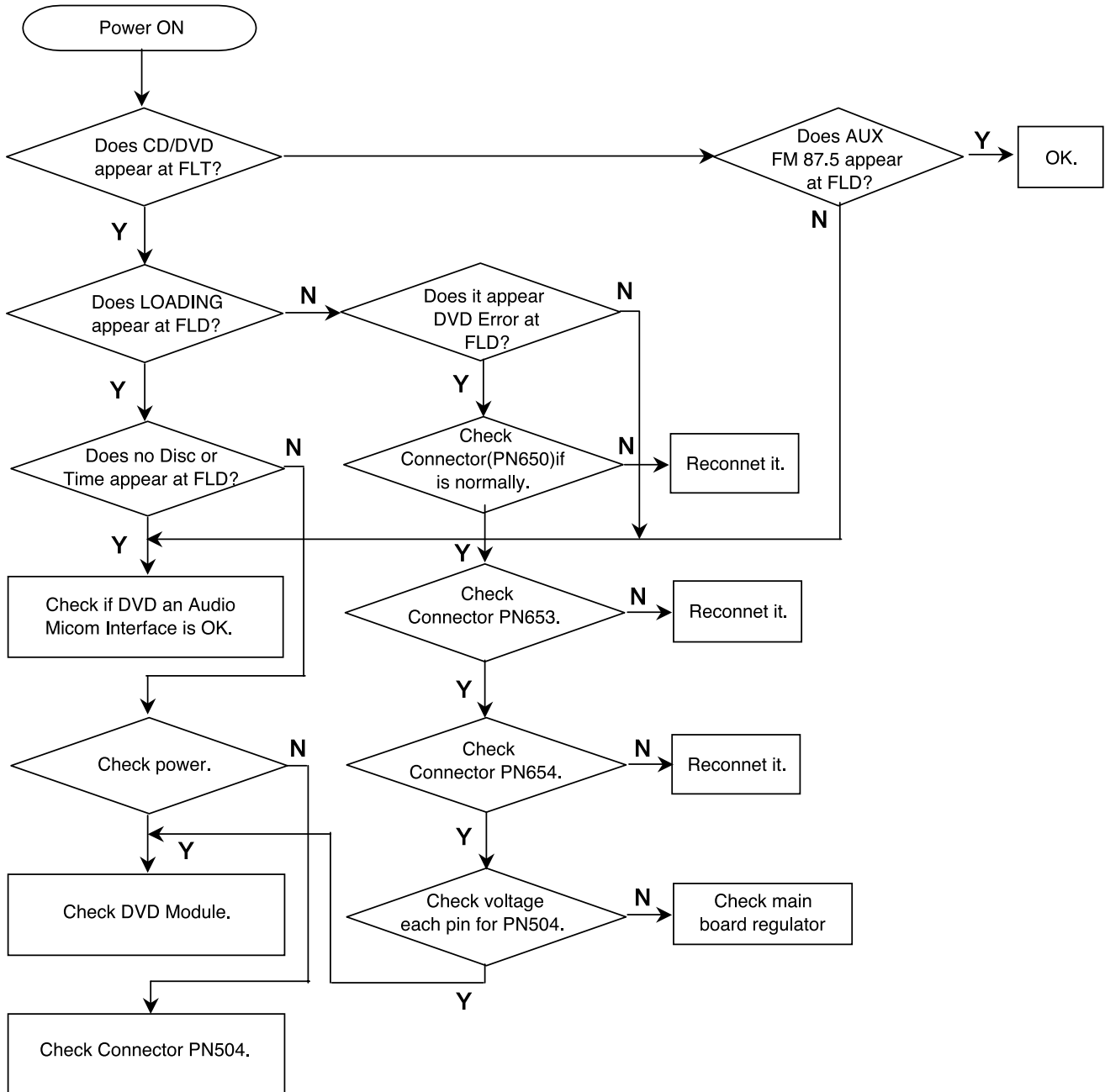

2. Test & debug flow

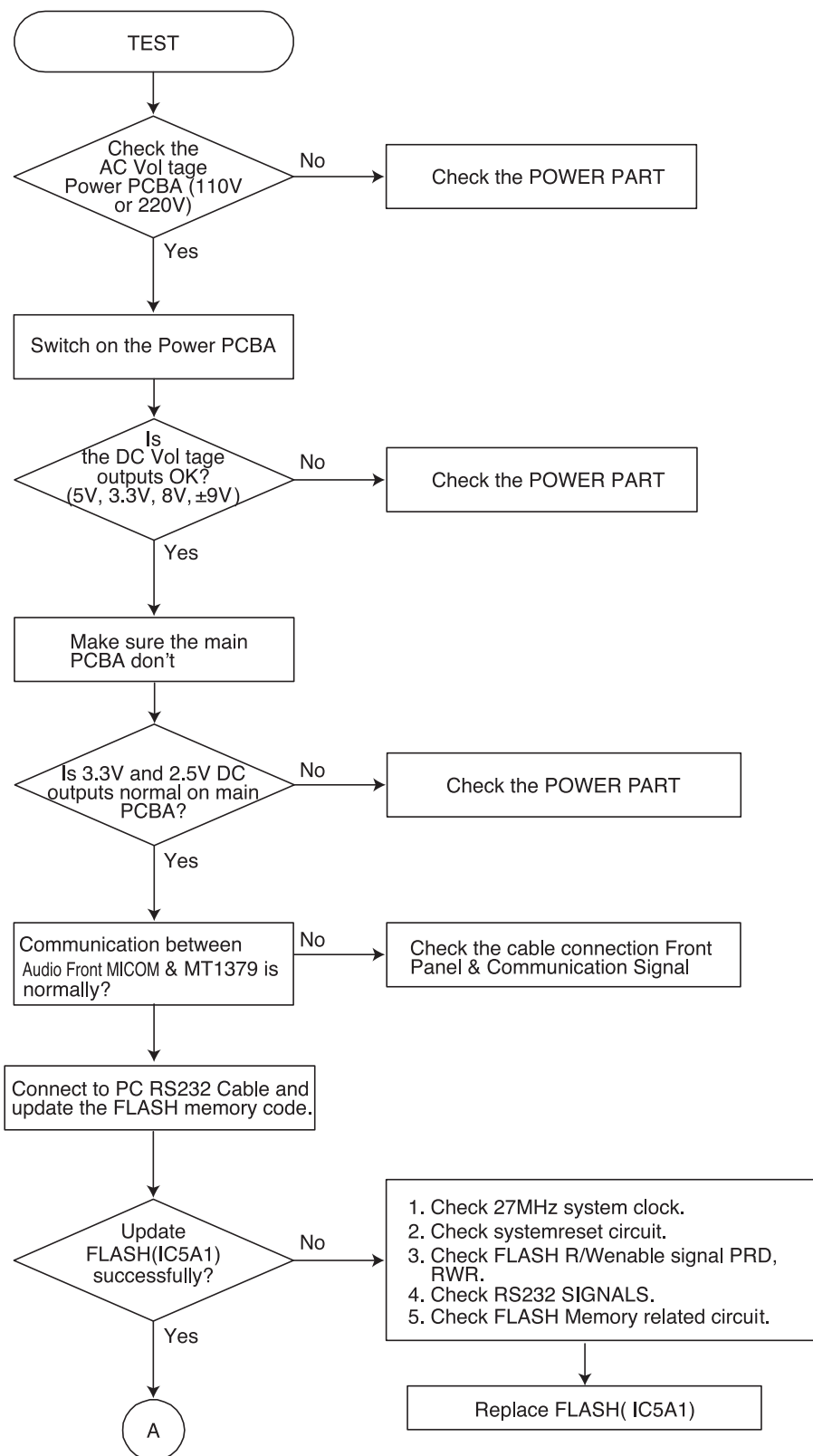

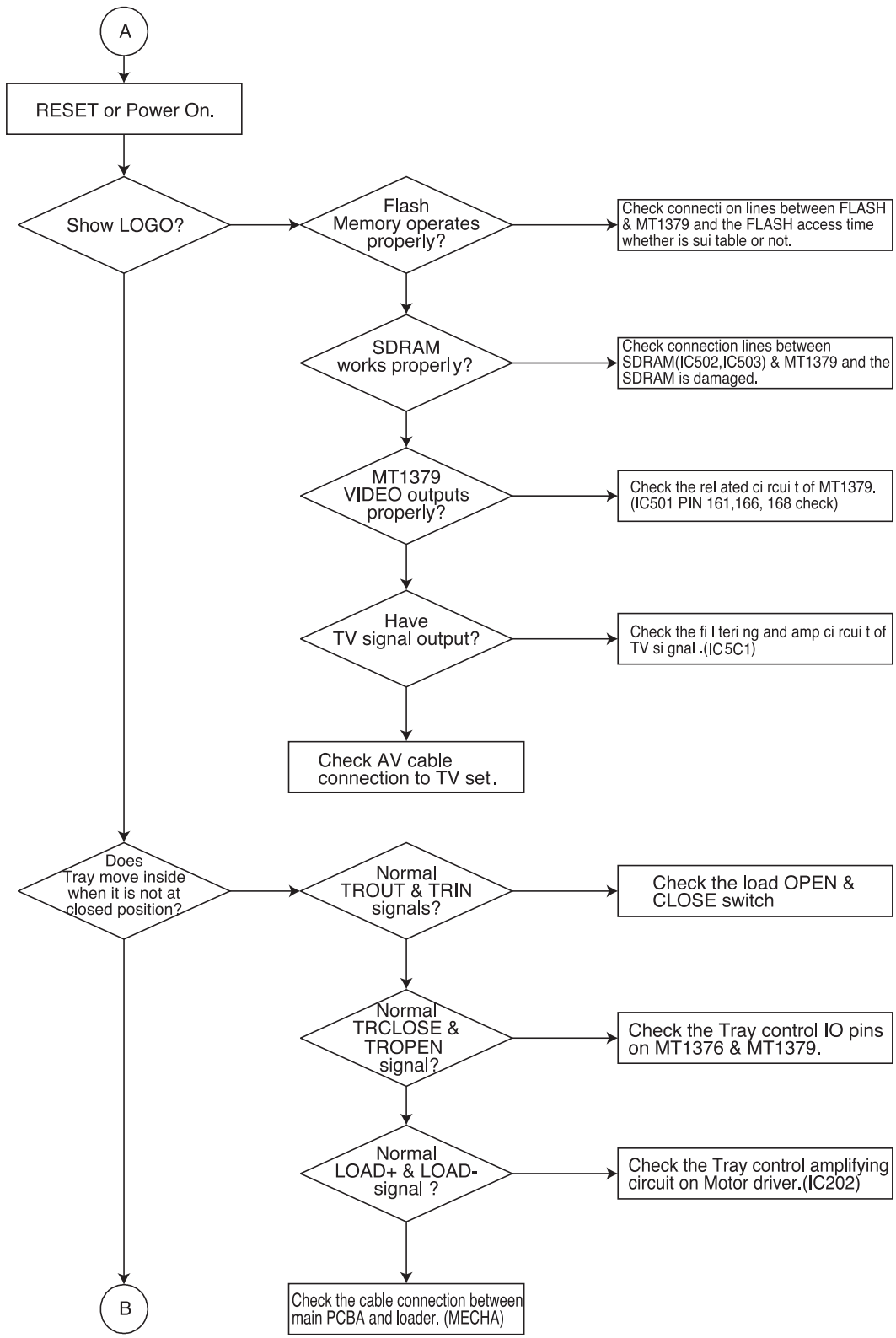

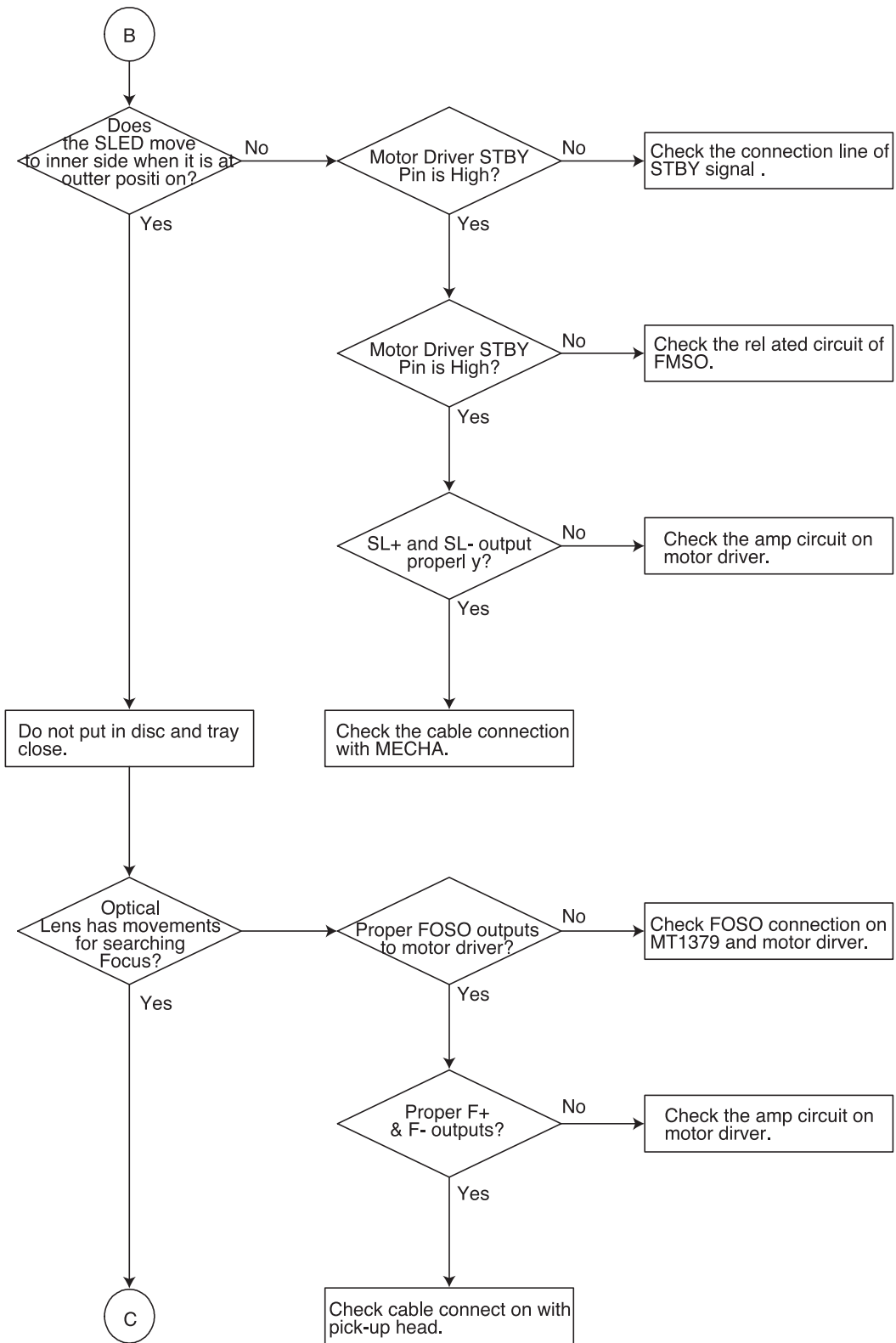

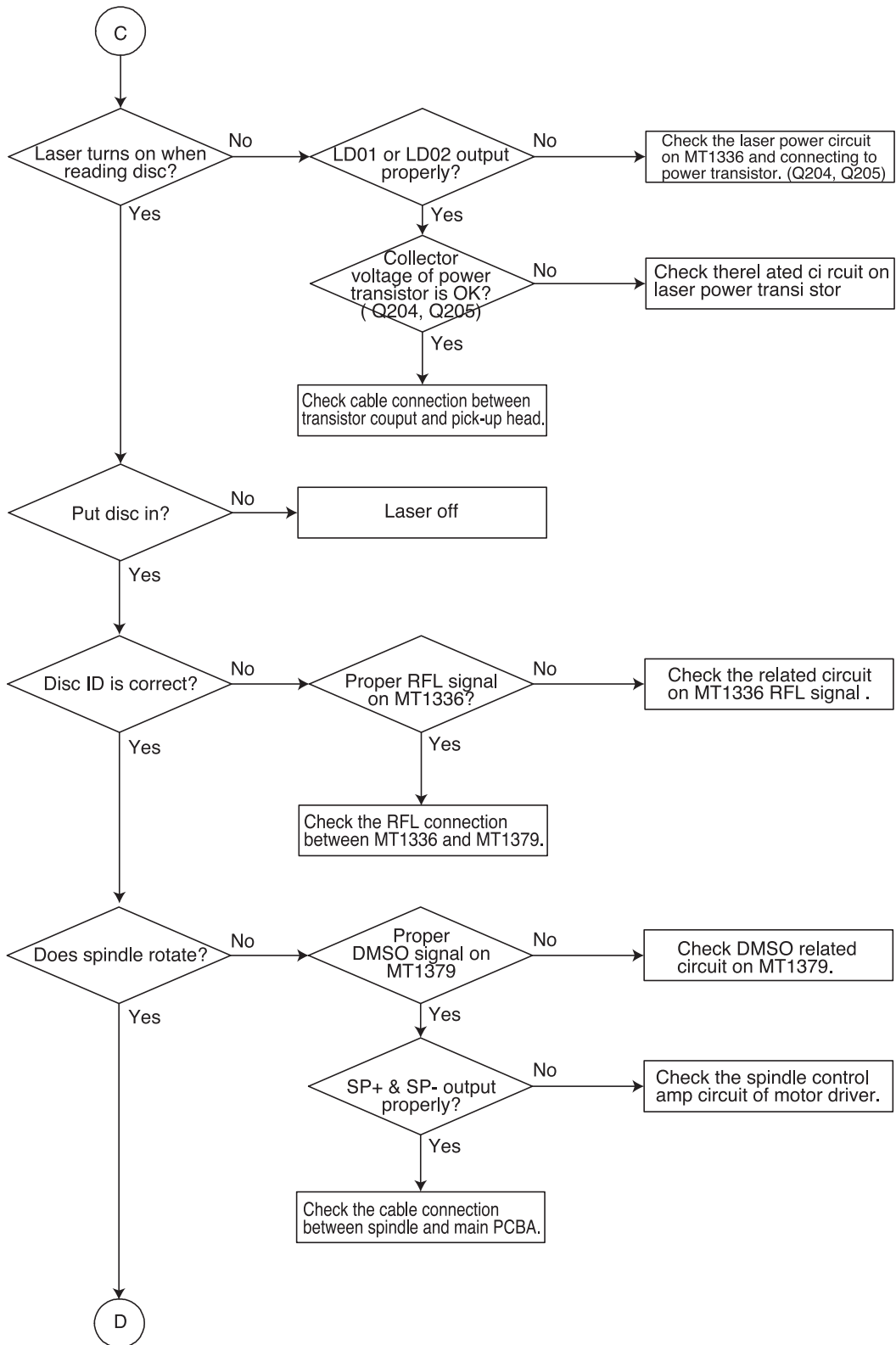

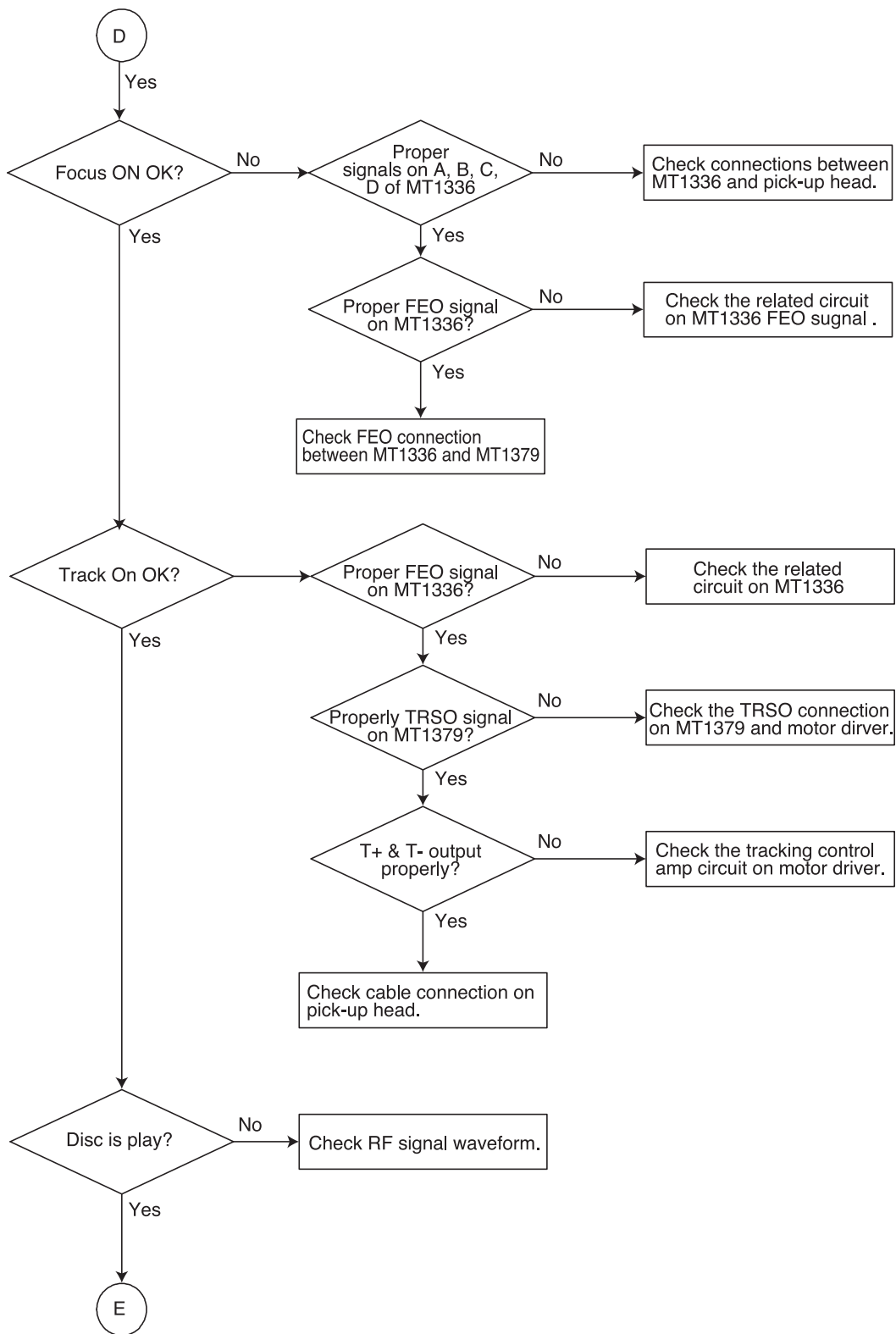

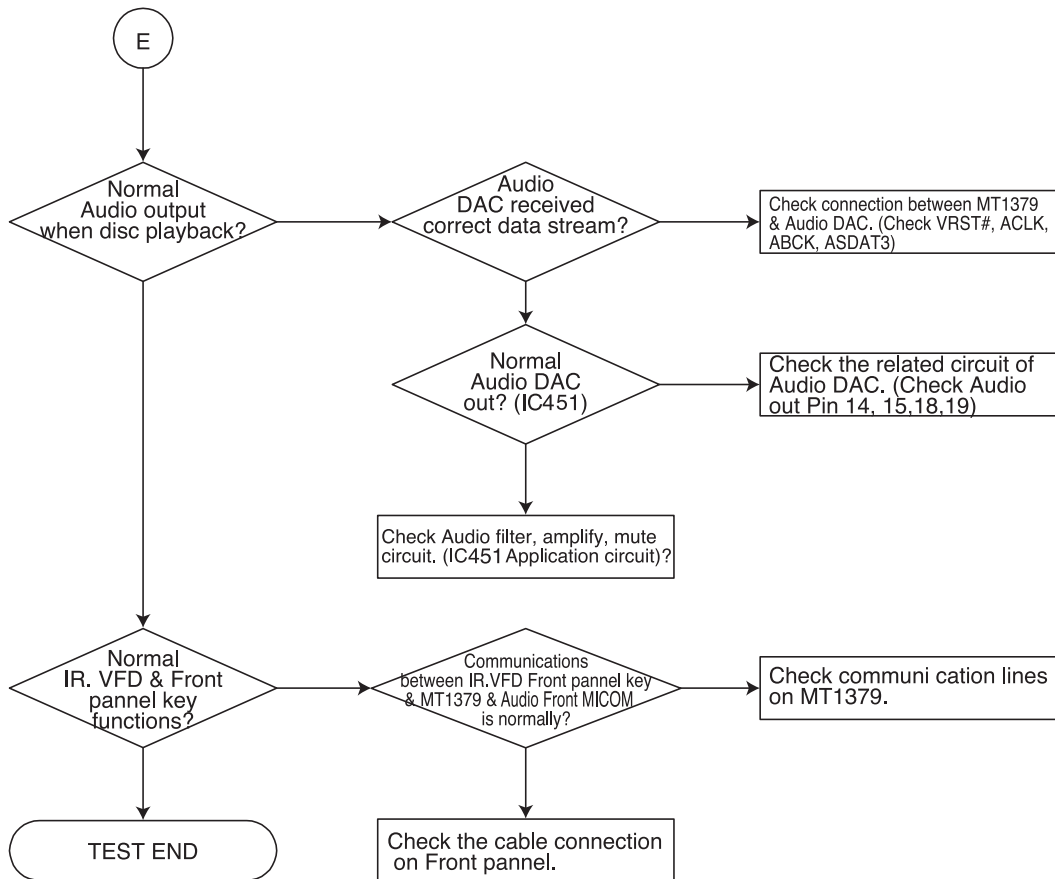

□ DETAILS AND WAVEFORMS ON SYSTEM TEST AND DEBUGGING

1. SYSTEM 27MHz CLOCK,RESET,FLASH R/W SIGNAL

1) MT1379 main clock is at 27MHz(X501)

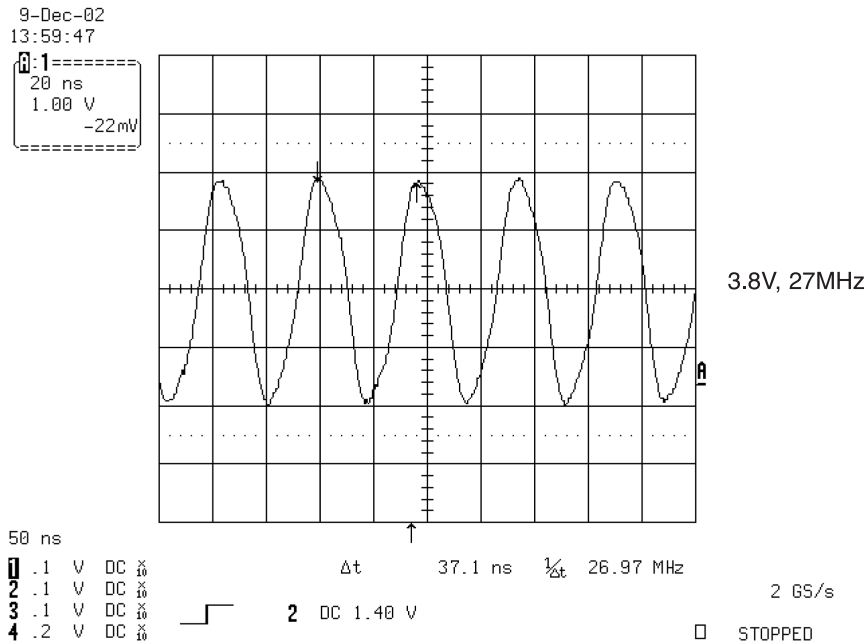

FIG 1-1

2) MT1336 reset is high active

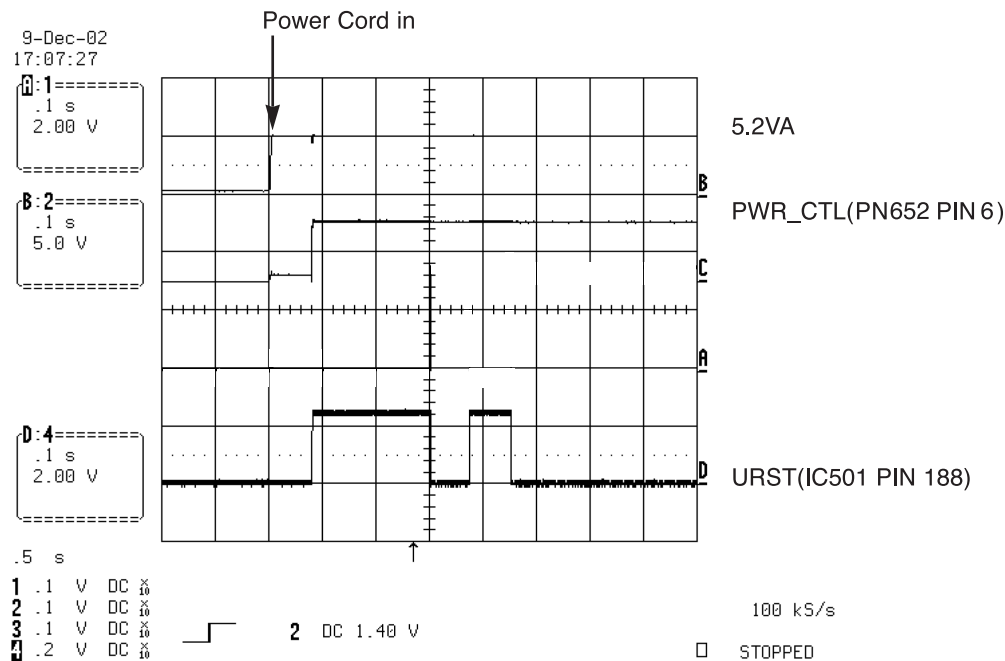

FIG 1-2

3) RS232 waveform during procedure(Downloading)

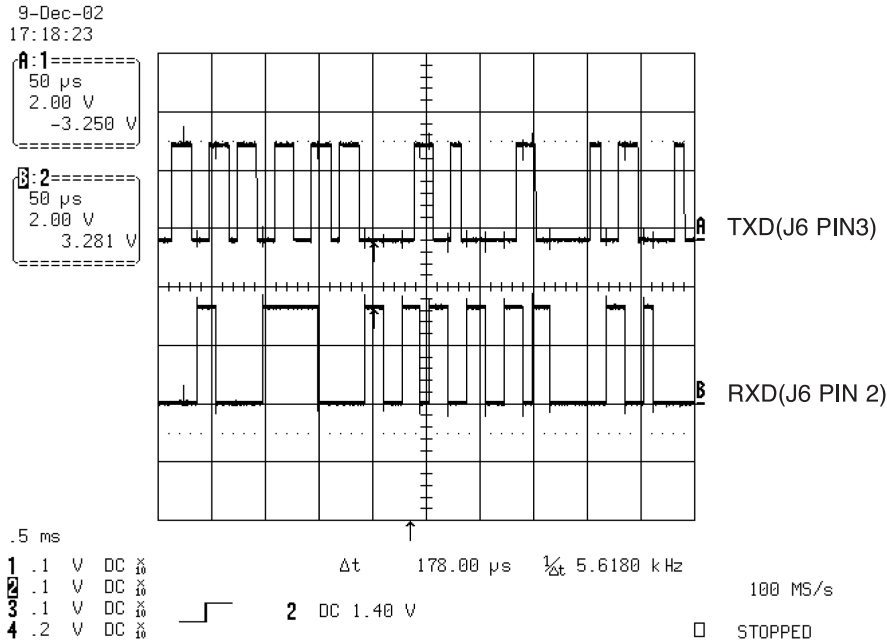

FIG 1-3

4) Flash R/W enable signal during download(Downloading)

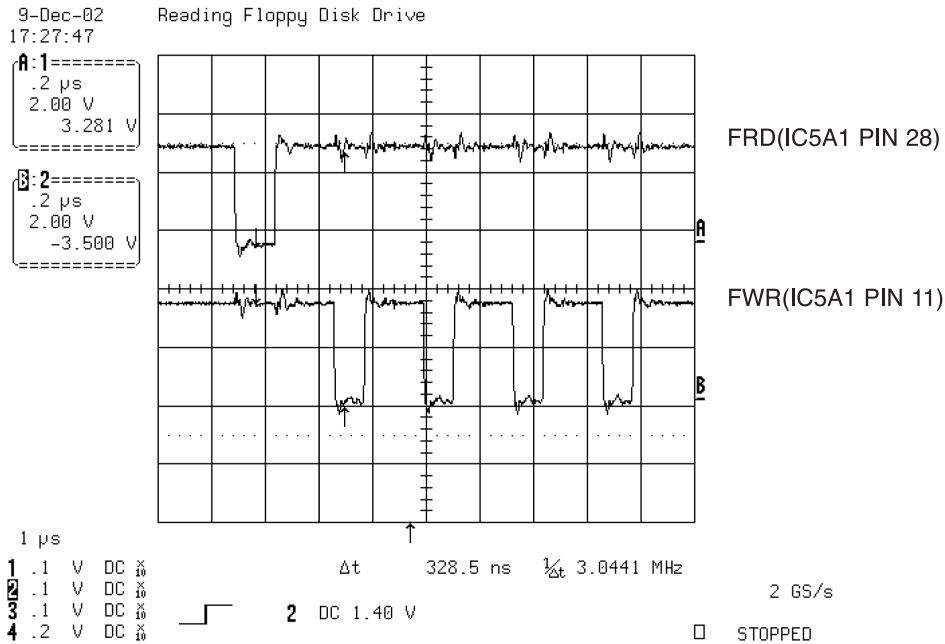

FIG 1-4

2. SDRAM CLOCK

1) MT1379 main clock is at 27MHz(X501)

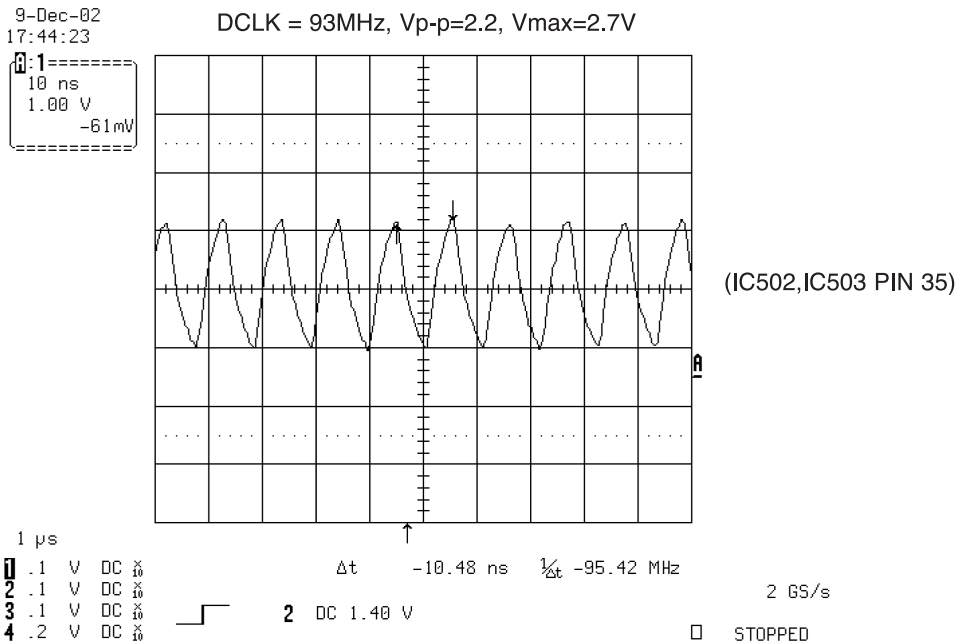

FIG 2-1

3. TRAY OPEN/CLOSE SIGNAL

1) Tray open/close waveform

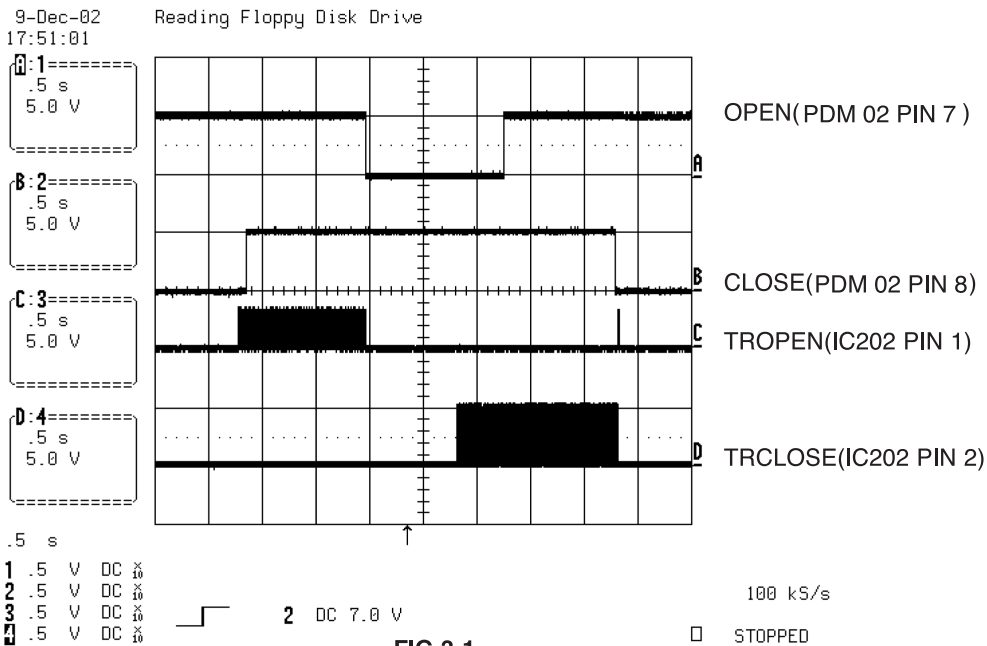

FIG 3-1

2) Tray close waveform

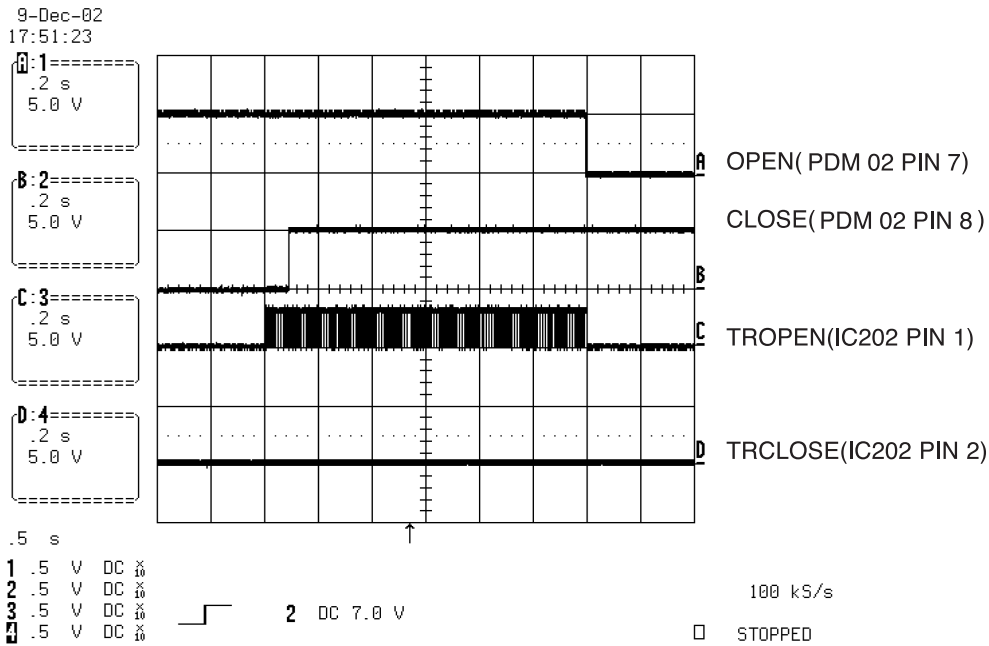

FIG 3-2

3) Tray open waveform

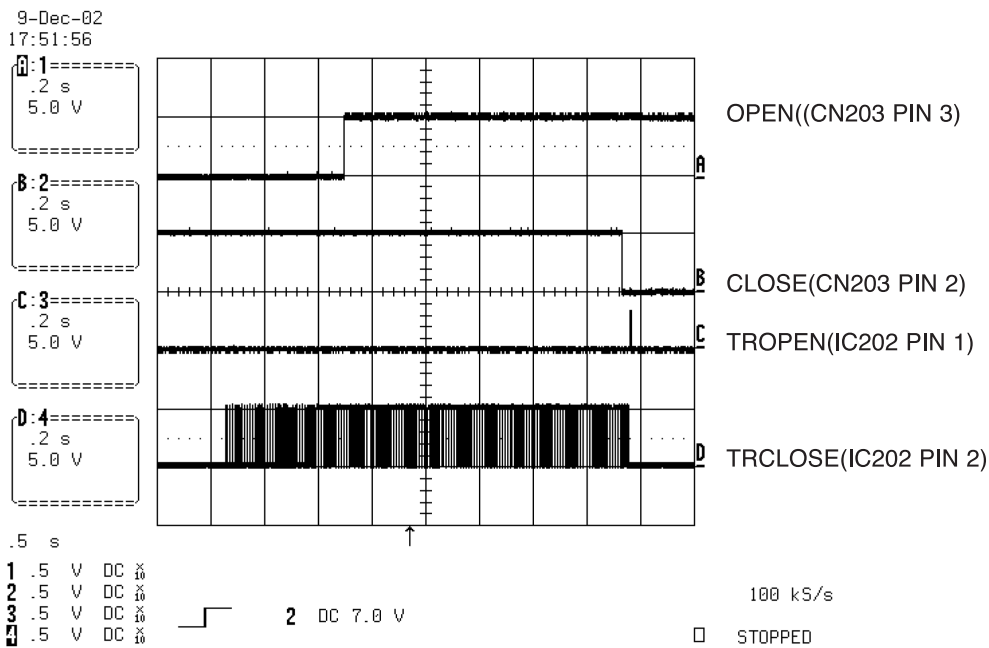

FIG 3-3

4. SLED CONTROL RELATED SIGNAL (NO DISC CONDITION)

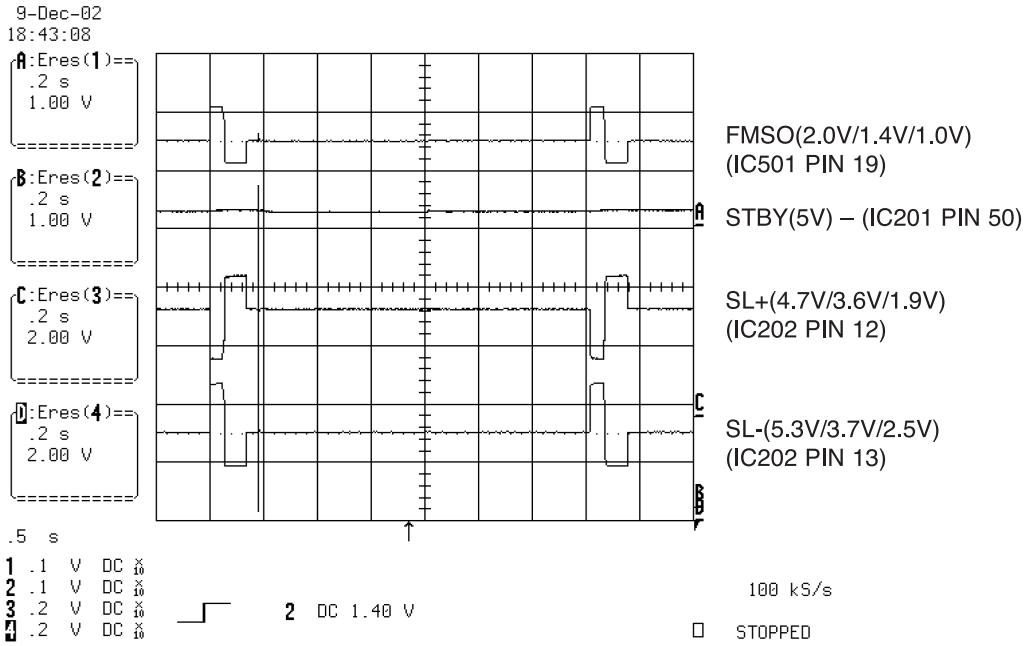

FIG 4-1

5. LENS CONTROL RELATED SIGNAL(NO DISC CONDITION)

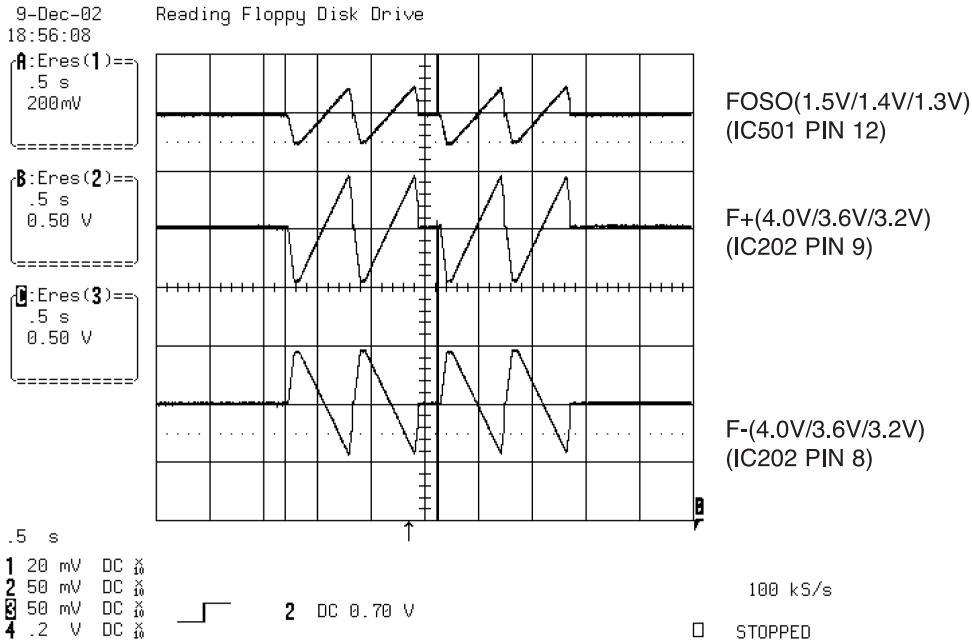

FIG 5-1

6. LASER POWER CONTROL RELATED SIGNAL (NO DISC CONDITION)

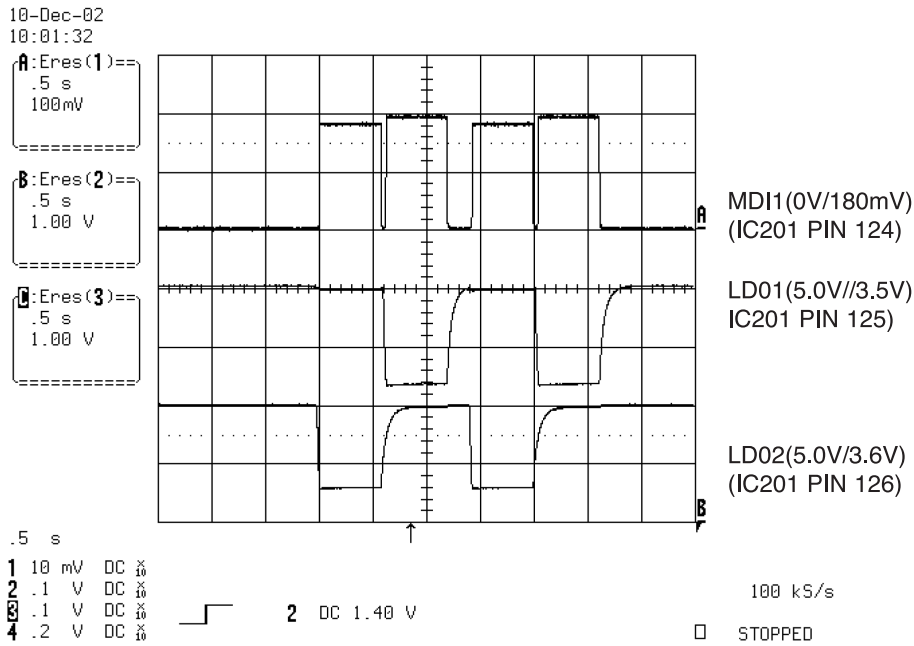

FIG 6-1

7. DISC TYPE JUDGEMENT WAVEFORM

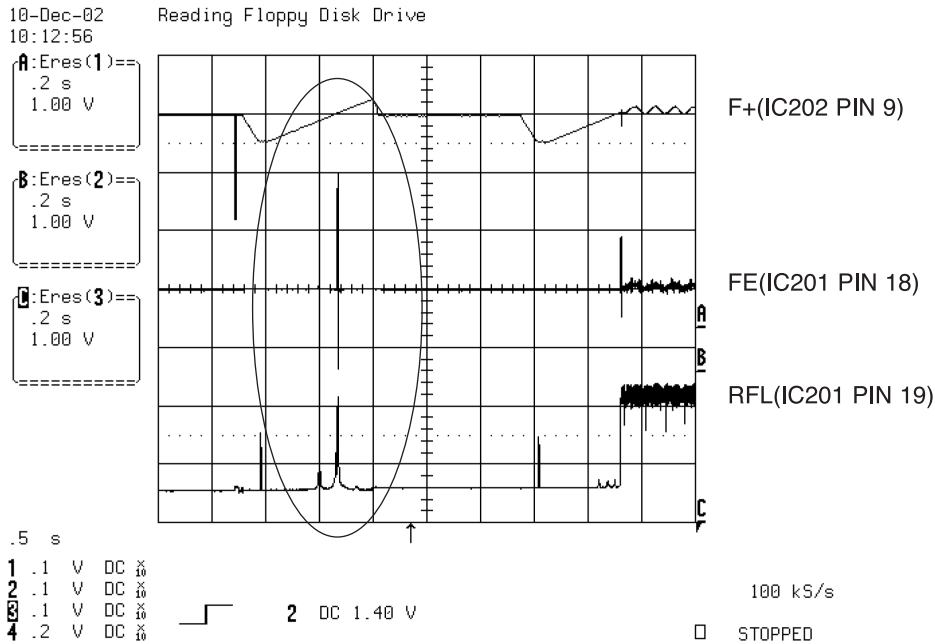

FIG 7-1 (DVD)

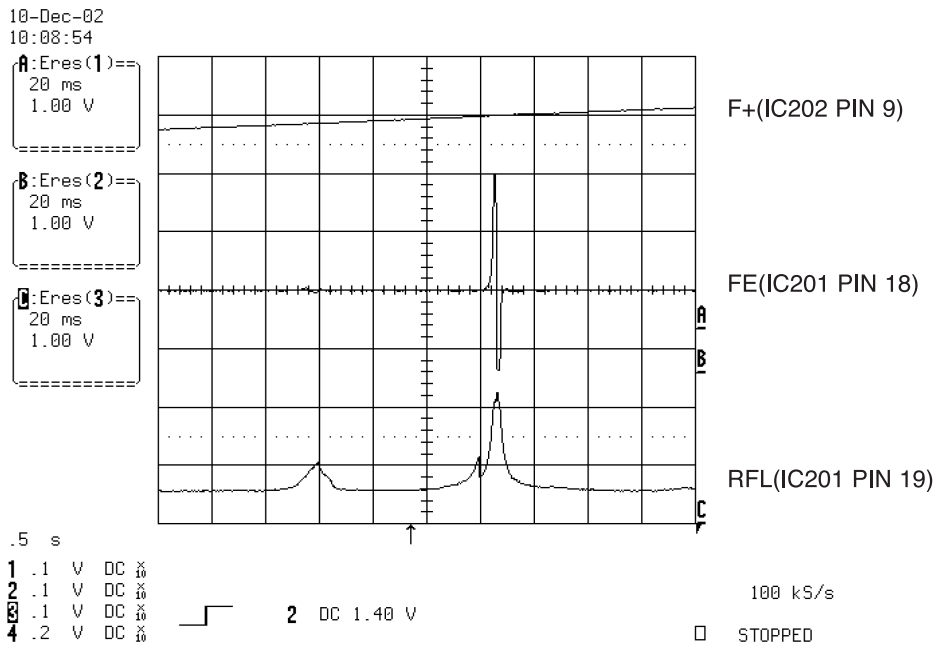

FIG 7-2 (DVD)

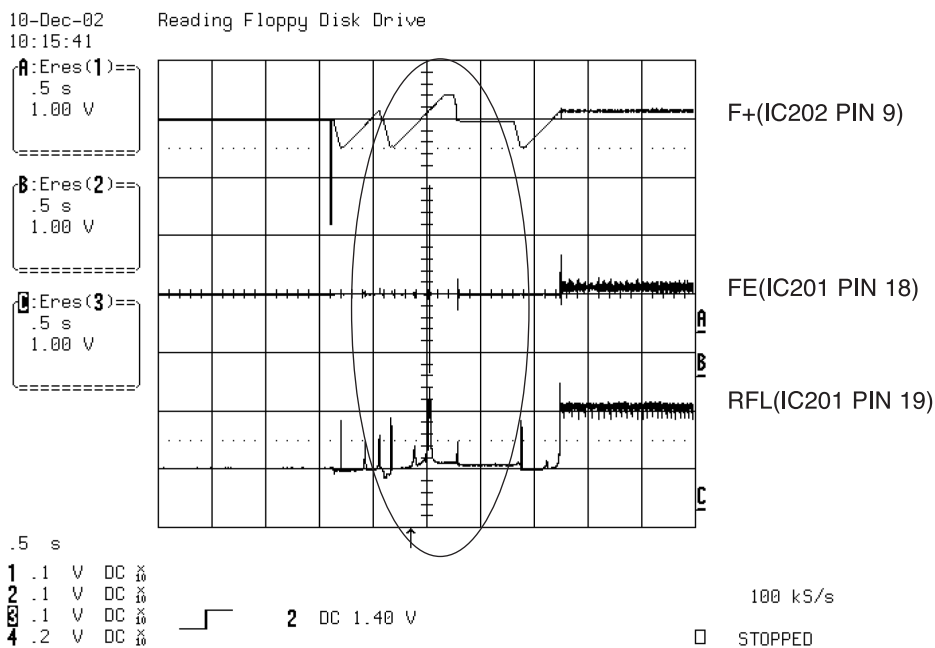

FIG 7-3 (CD)

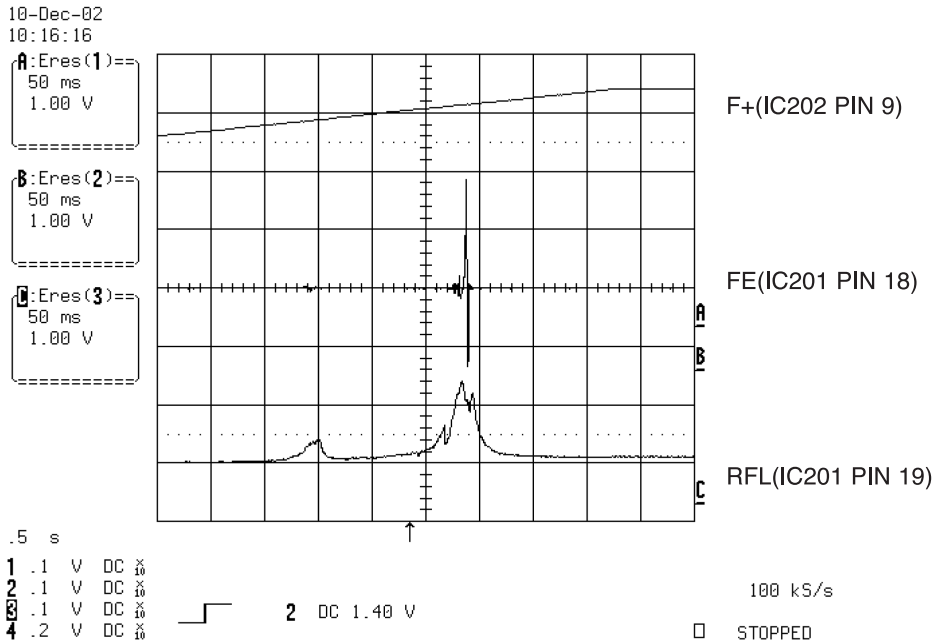

FIG 7-4 (CD)

8. FOCUS ON WAVEFORM

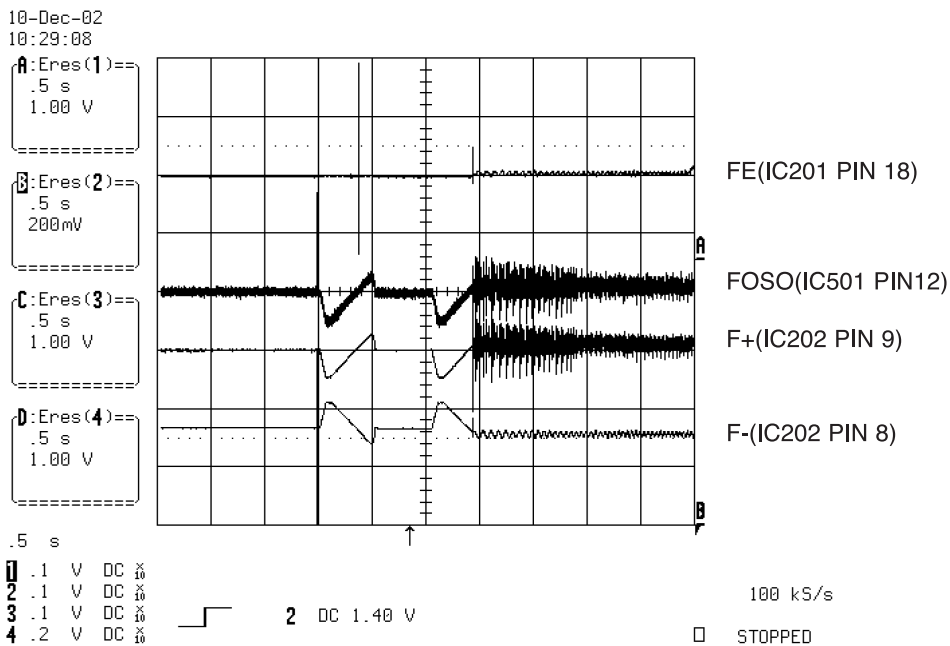

FIG 8-1 (DVD)

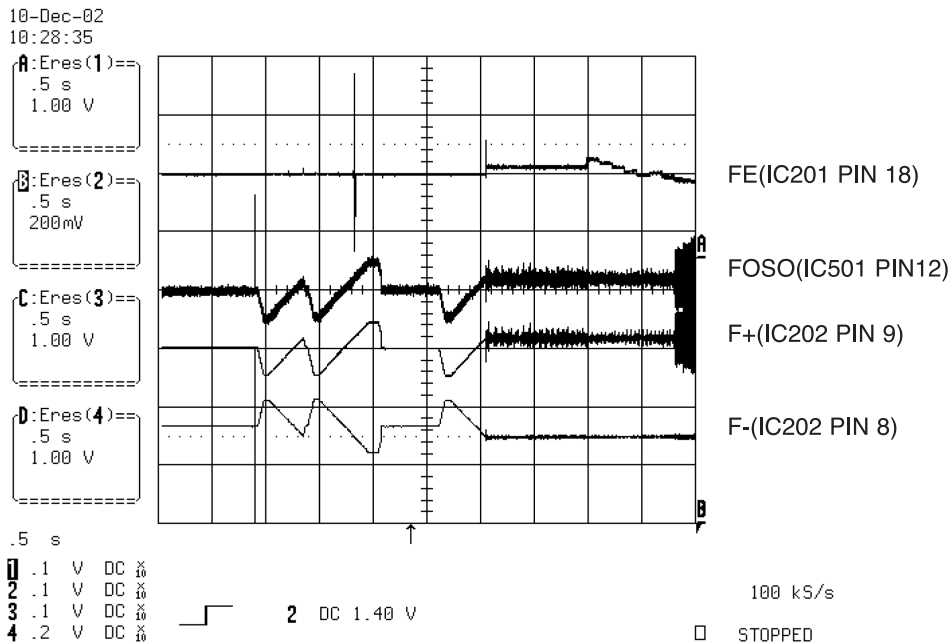

FIG 8-2 (CD)

9. SPINDLE CONTROL WAVEFORM (NO DISC CONDITION)

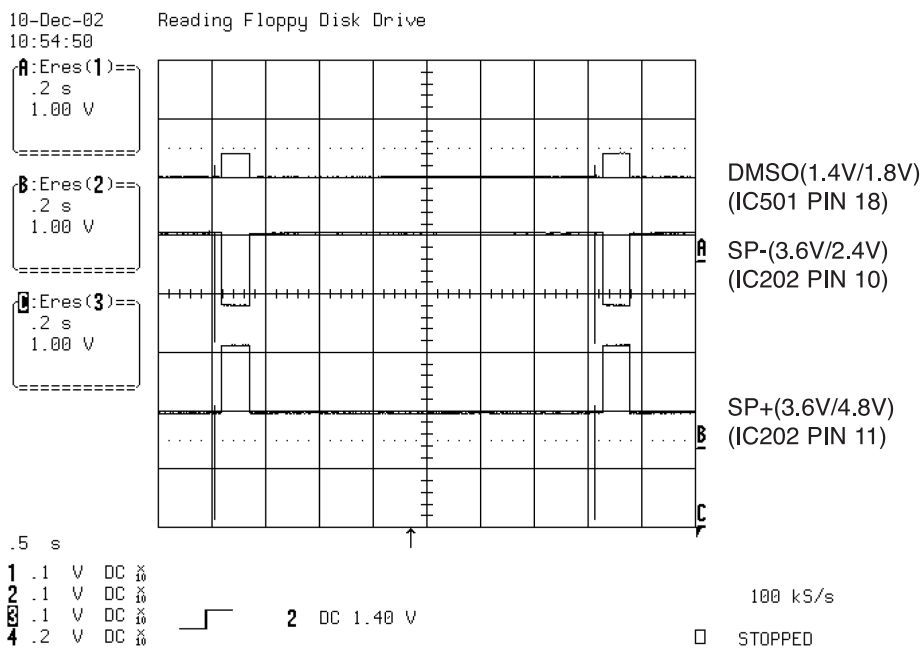

FIG 9-1

10. TRACKING CONTROL RELATED SIGNAL(System checking)

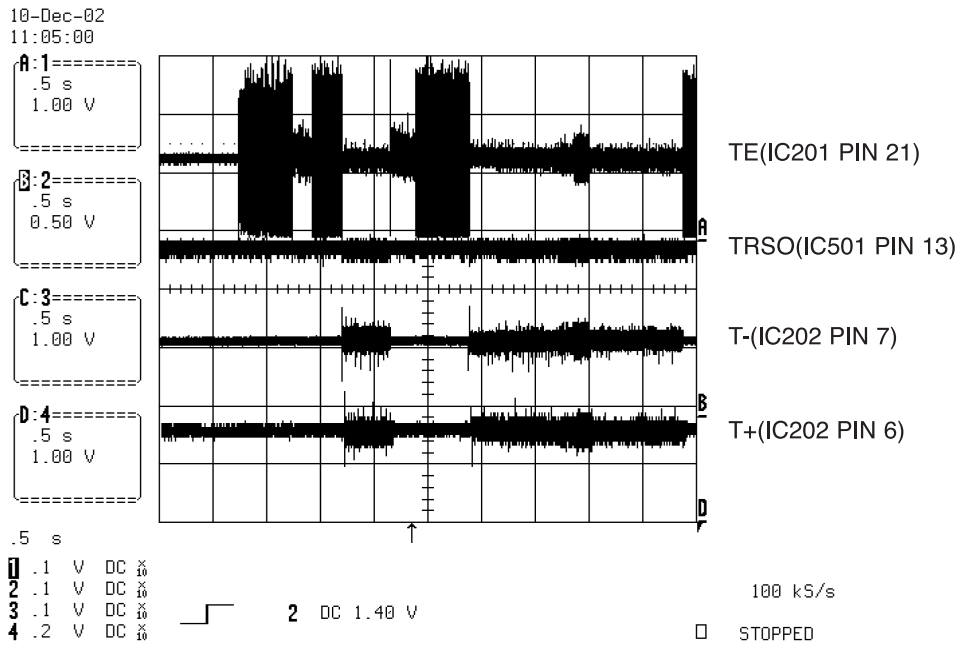

FIG 10-1(DVD)

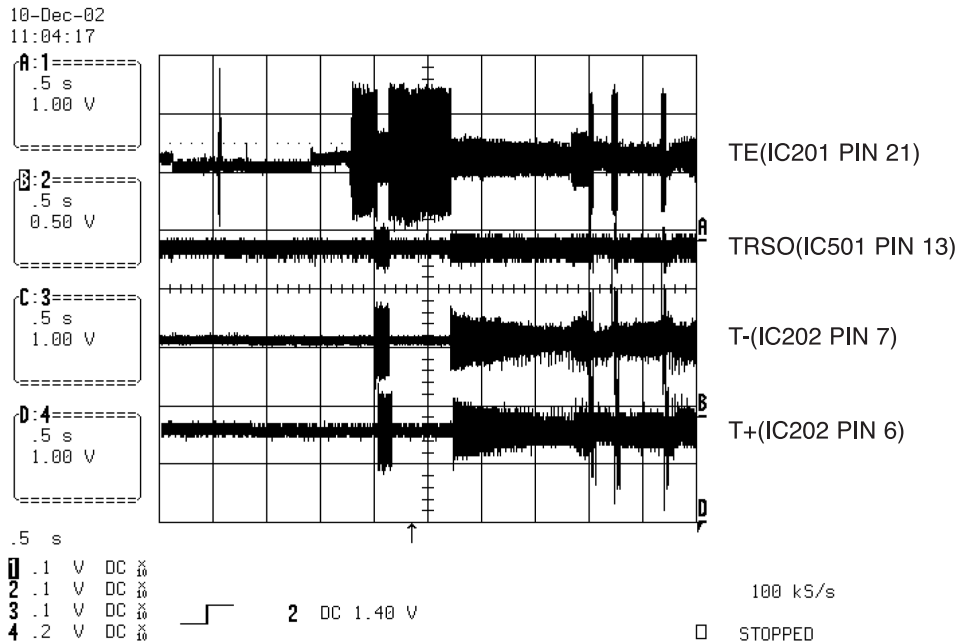

FIG 10-2(CD)

11. RF WAVEFORM

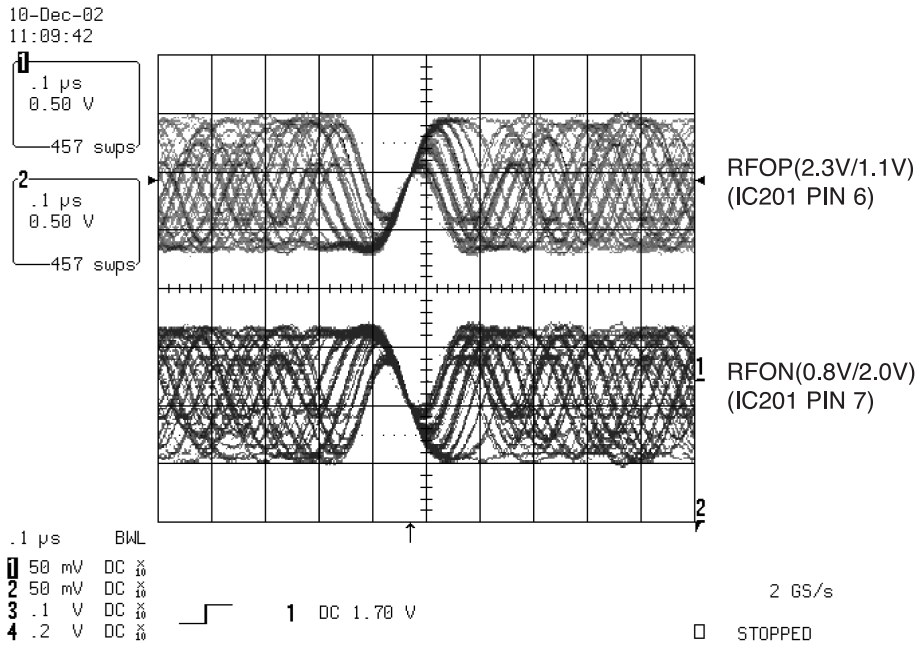

FIG 11-1

12. MT1379 AUDIO OPTICAL AND COAXIAL OUTPUT (ASPDIF)

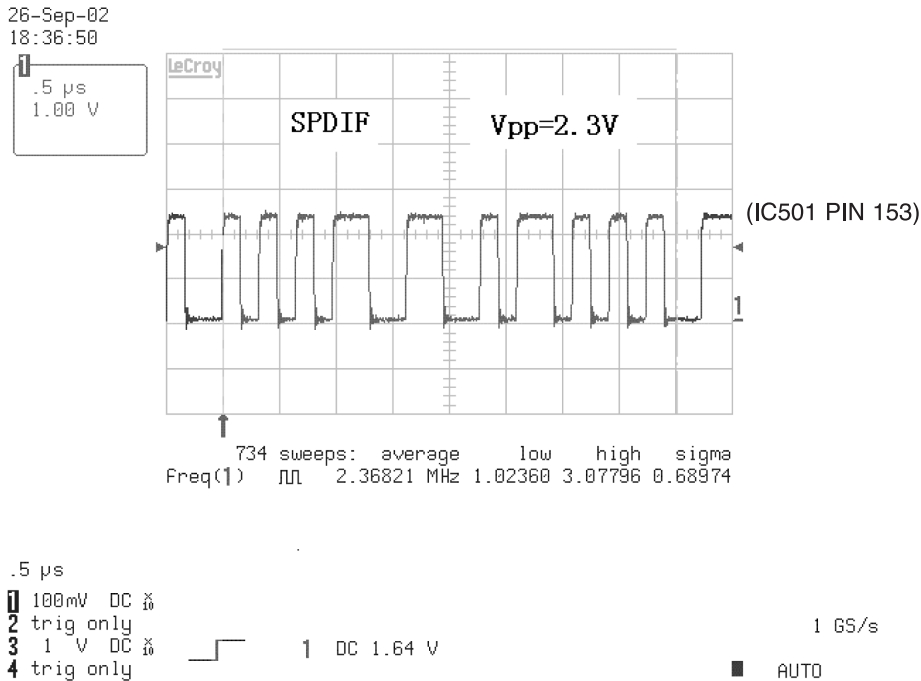

FIG 12-1

13. MT1379 VIDEO OUTPUT WAVEFORM

1) Full colorbar signal(CVBS)

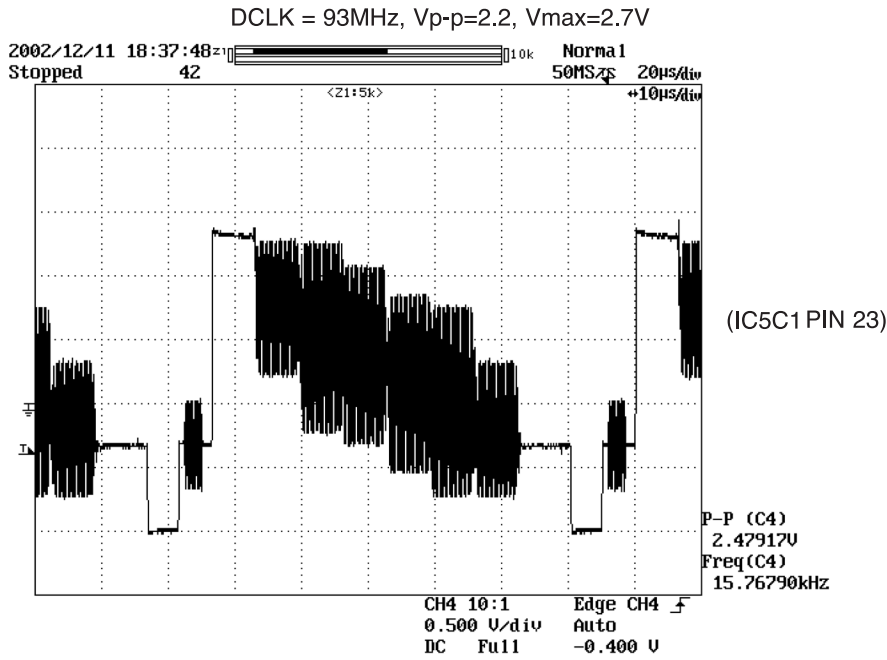

FIG 13-1

2) Y

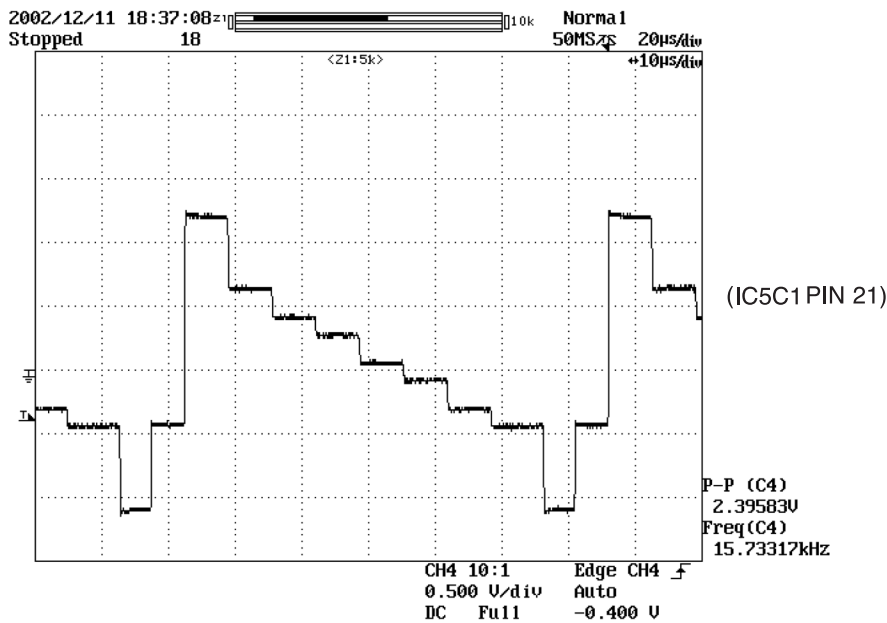

FIG 13-2

3) C

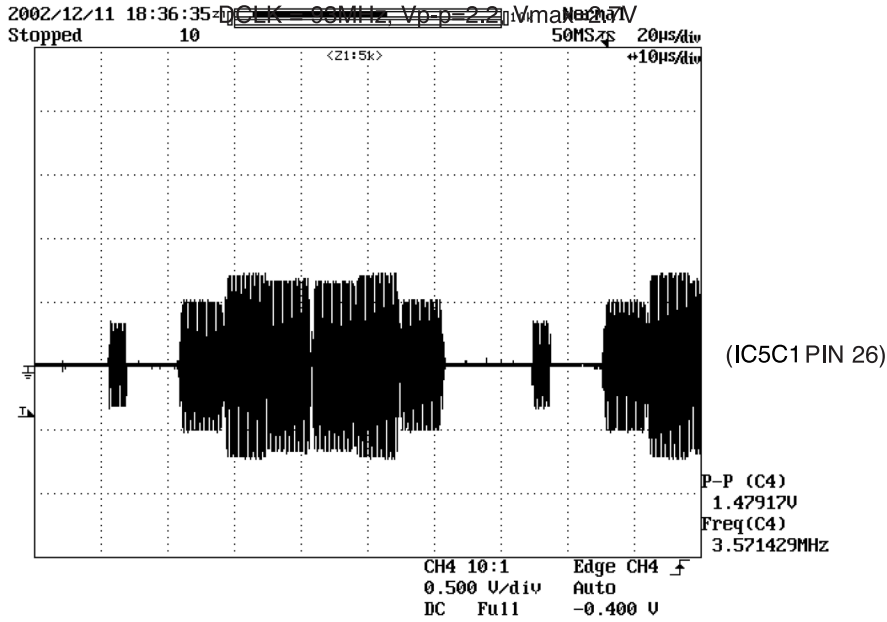

FIG 13-3

14. AUDIO OUTPUT FORM AUDIO DAC

1) Audio related Signal

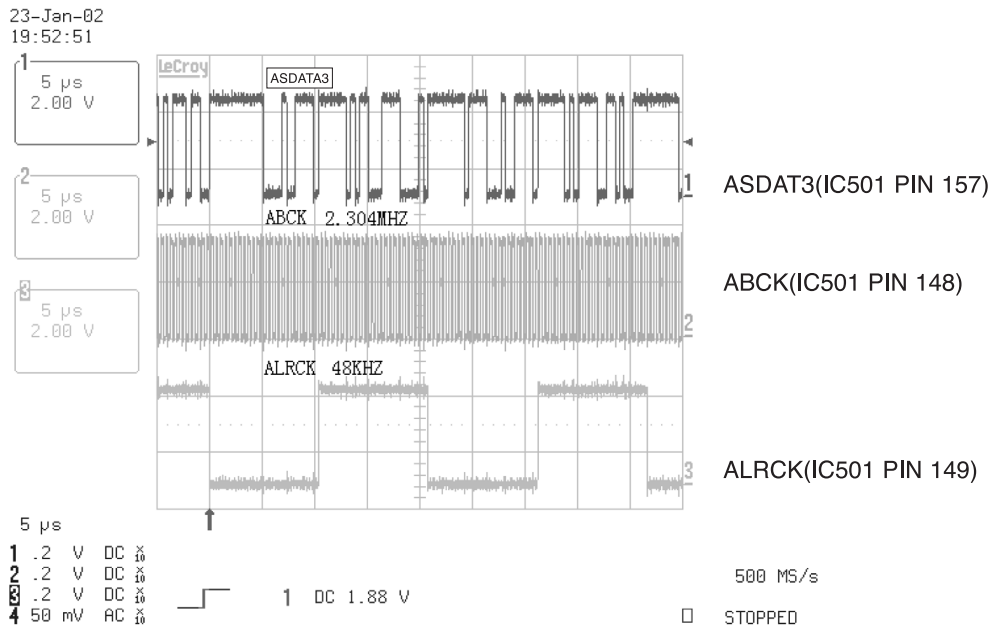
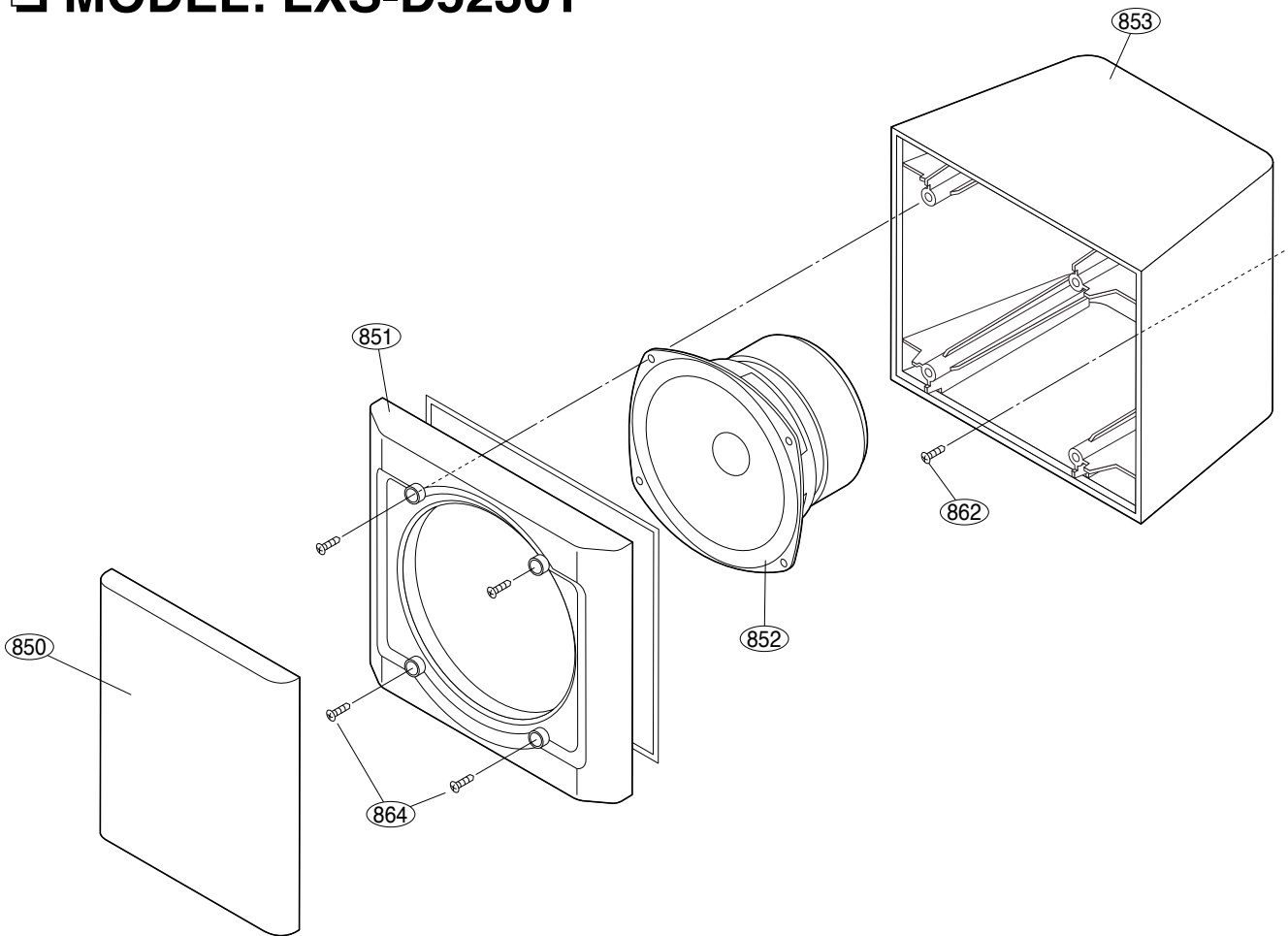

FIG 14-1

SECTION 5. SPEAKER SECTION

□ MODEL: LXS-D5230T



□ MODEL: LXS-D5230V

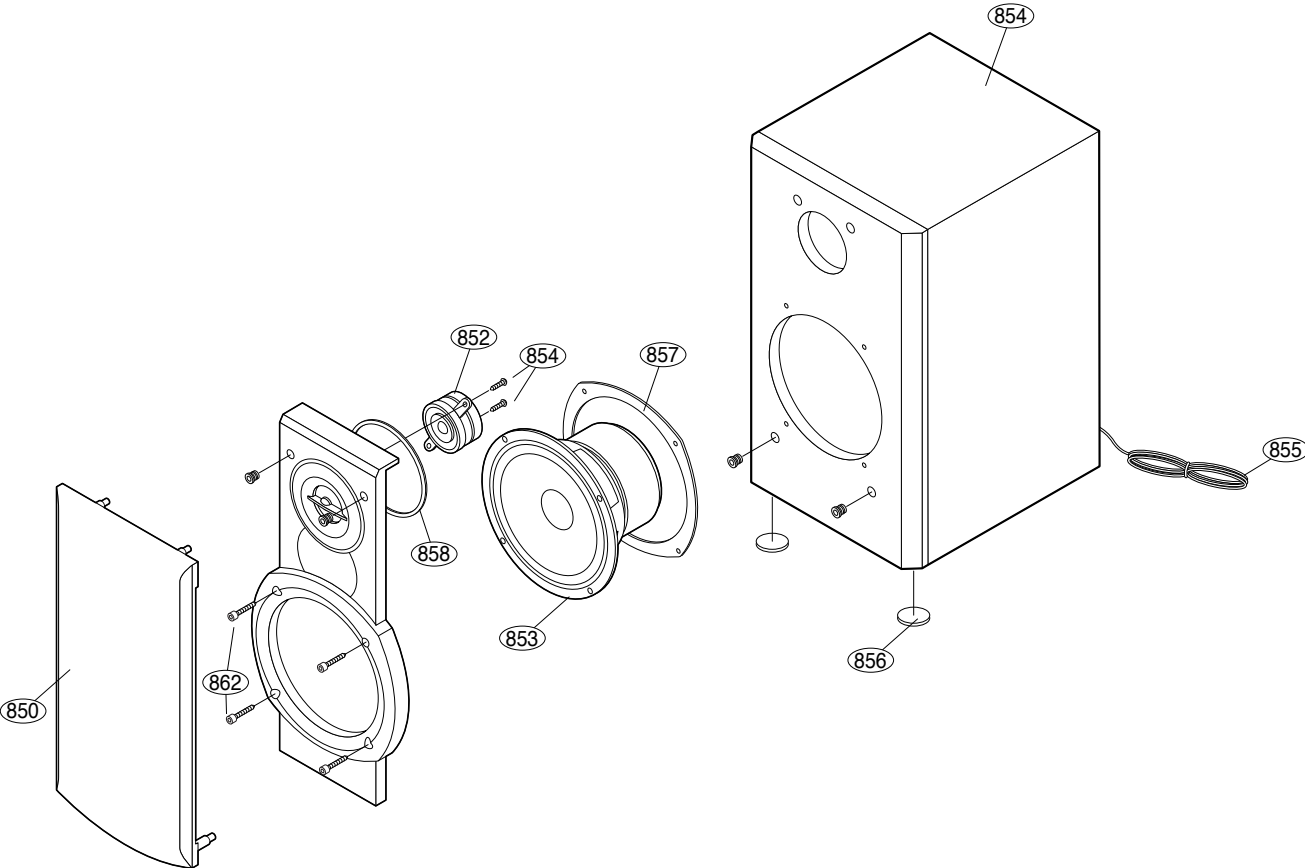

RUN DATE : 23.MAY.2003

□ MODEL: LXS-D5230C

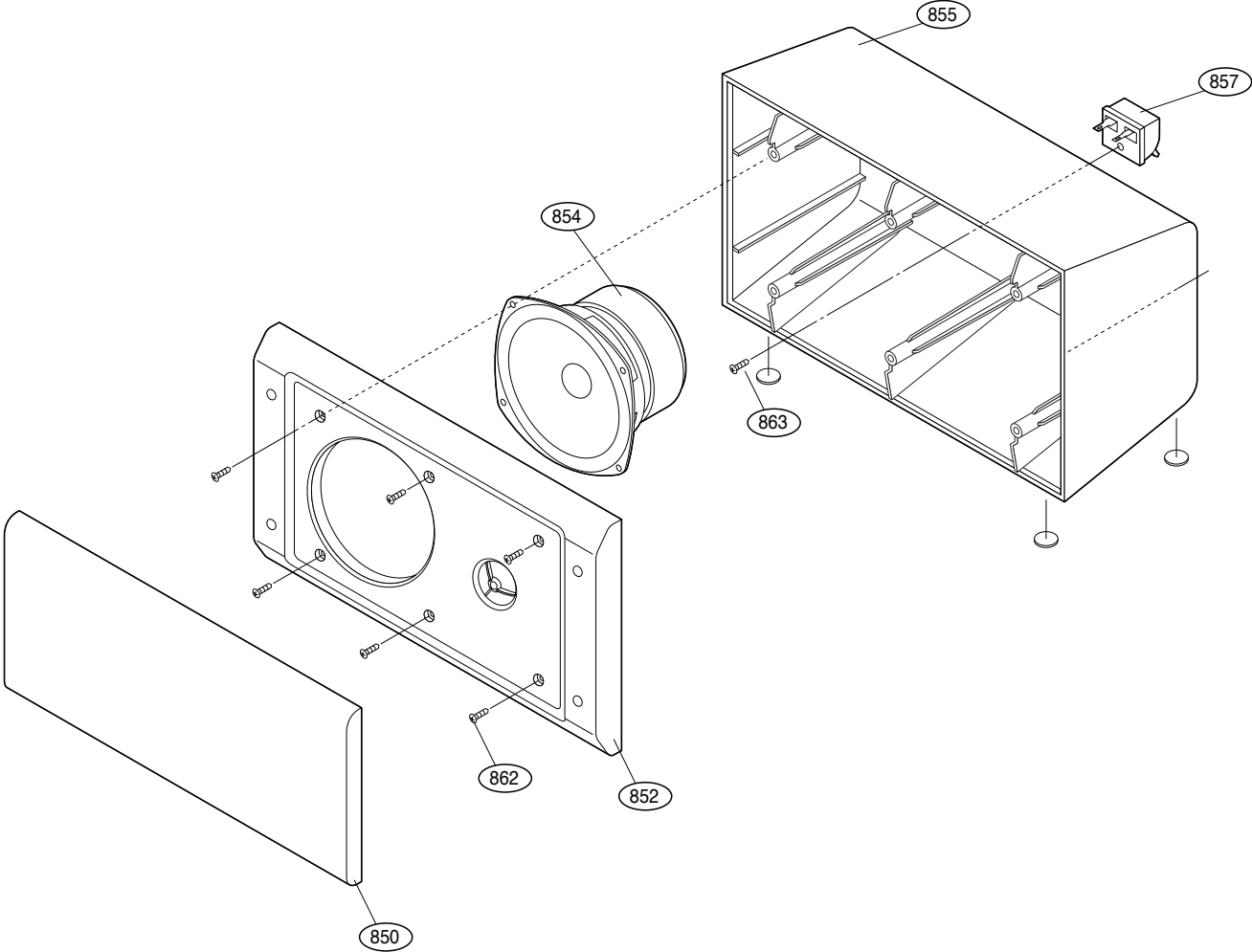

RUN DATE : 23.MAY.2003

□ BLOCK DIAGRAM

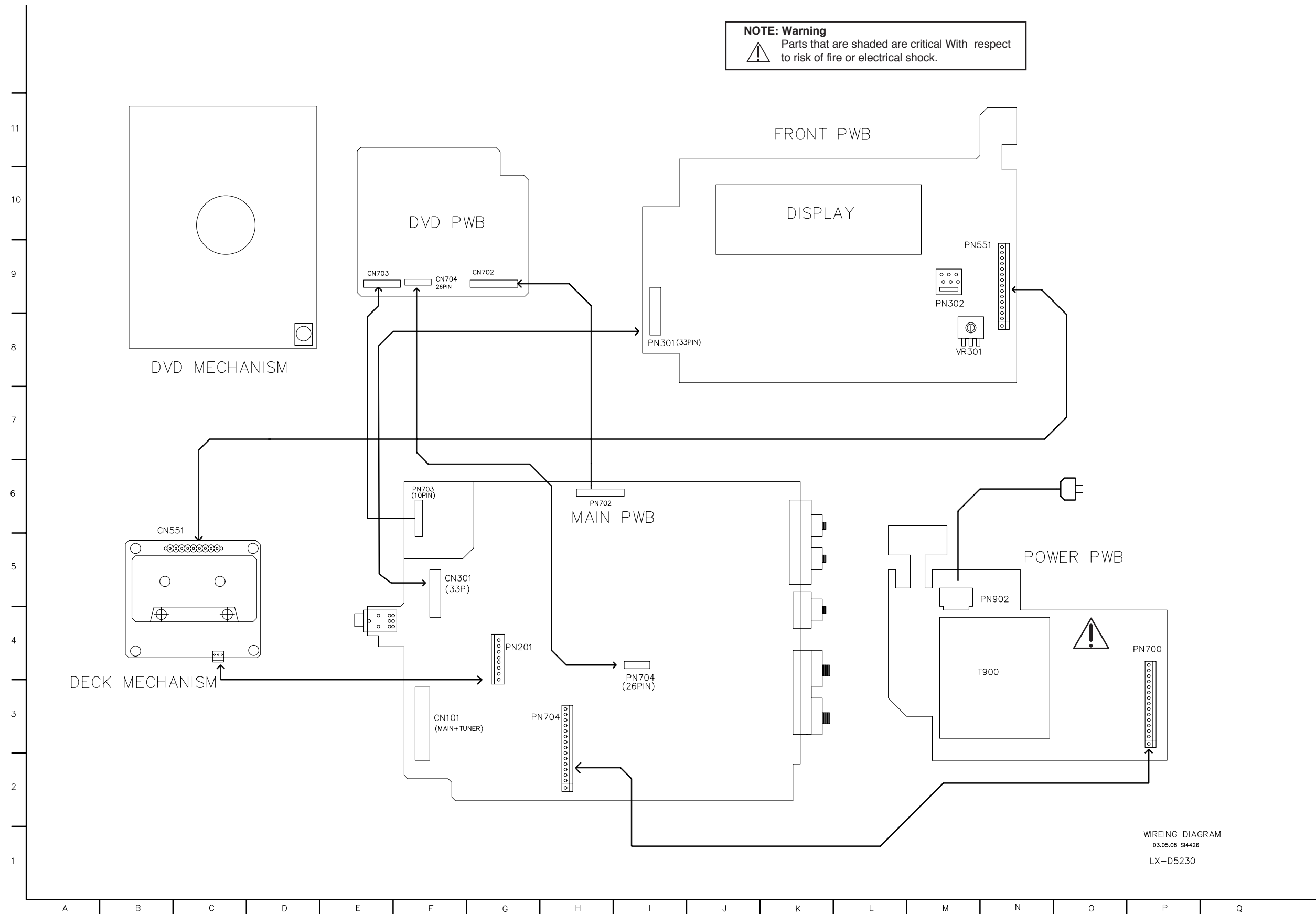

SCHEMATIC DIAGRAMS

MAIN SCHEMATIC DIAGRAM

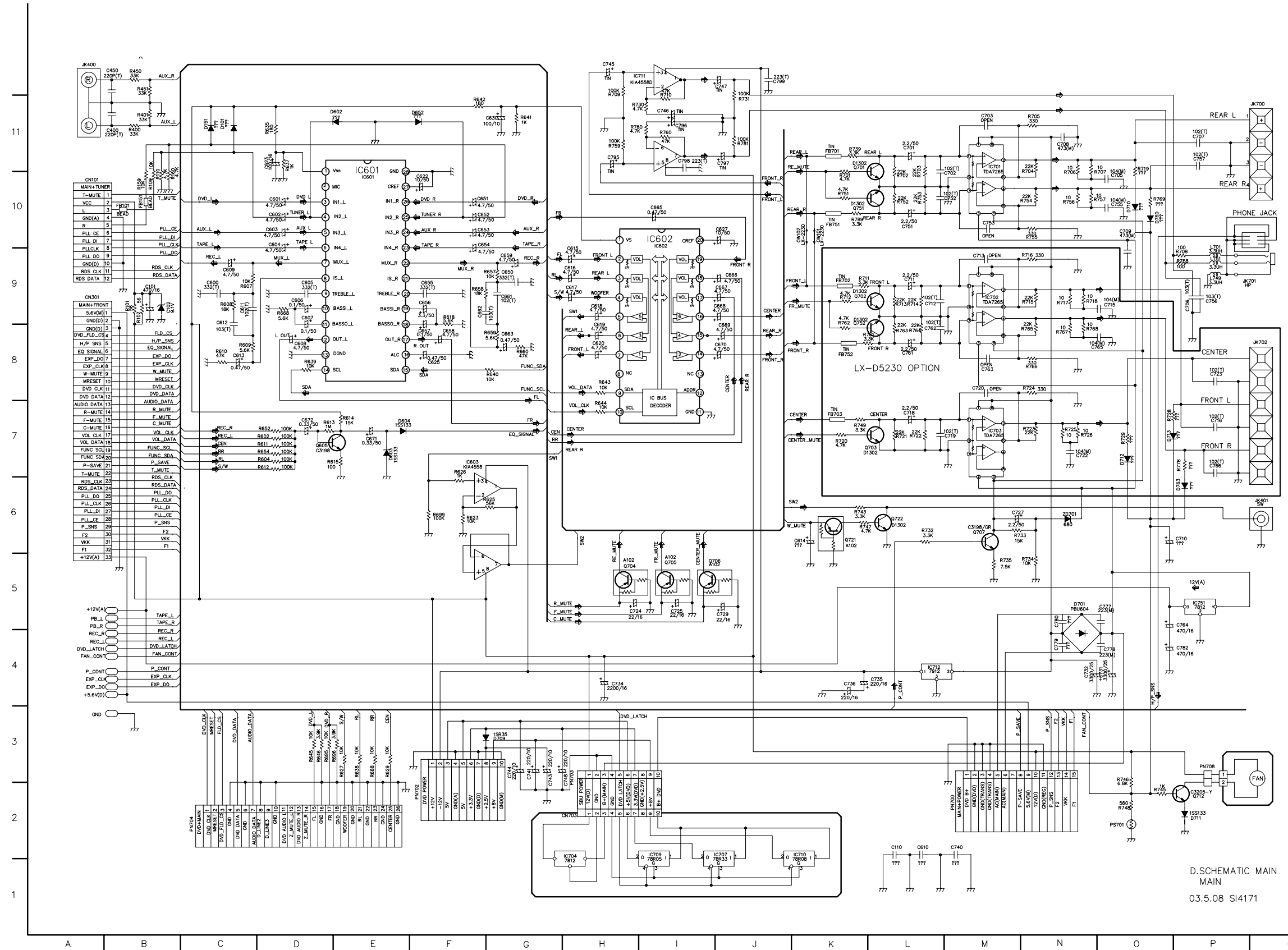

LOCATION GUIDE

C101	B9	C798	I11	R657	F9
C102	B9	C799	J12	R658	F9
C110	L2	CN101	A10	R659	F8
C400	B11	CN301	A9	R660	G8
C450	B12	CN703	H2	R668	D9
C600	C9	D101	C11	R688	D3
C601	D10	D151	C11	R695	D3
C602	D10	D602	D11	R696	E3
C603	D10	D603	E7	R699	F6
C604	D10	D604	E7	R701	K10
C605	D9	D652	F11	R702	L10
C606	D9	D701	N5	R703	L10
C607	D9	D709	G3	R704	N10
C608	D8	D710	O10	R705	N11
C609	C9	D711	G2	R706	N10
C610	L2	D712	O7	R707	N10
C611	C9	D713	O7	R708	P9
C612	C9	D760	O10	R709	H11
C613	C8	D763	P6	R710	I11
C614	K6	FB101	B10	R711	K9
C615	H9	FB151	B10	R712	K9
C616	H9	FB701	K11	R713	L9
C617	H9	FB702	K9	R714	L9
C618	H9	FB703	K7	R715	N9
C619	H8	FB751	K10	R716	N9
C620	H8	FB752	K8	R717	N9
C622	F10	IC601	E10	R718	N9
C623	D11	IC602	I10	R719	N10
C625	F8	IC603	F7	R720	K7
C627	O10	IC701	M11	R721	L7
C630	G11	IC702	M9	R722	L7
C650	G9	IC703	M7	R723	N7
C651	F10	IC704	H2	R724	N8
C652	F10	IC707	I2	R725	N7
C653	F10	IC709	I2	R726	N7
IC710	F10	IC710	K2	R728	O7
C655	F9	IC711	H12	R729	O7
C656	F9	IC712	L4	R730	H11
C657	F8	IC751	P5	R731	J11
C658	F8	JK400	A12	R732	L6
C659	G9	JK401	G6	R733	M6
C661	G9	JK700	O11	R734	N5
C662	F9	JK701	P9	R735	M5
C663	G8	JK702	O8	R739	K11
C665	O10	L701	P9	R743	K6
C666	J9	L749	P9	R745	O2
C667	J9	L751	P9	R746	O2
C668	J9	OW101	K10	R747	K6
C669	J8	OW102	K10	R748	O2
C670	J8	PN700	M2	R749	K7
C671	E7	PN702	F2	R751	K10
C672	O7	PN703	H2	R752	L10
C701	L11	PN704	C2	R753	L10
C702	M10	PN708	P3	R754	N10
C703	M11	PS701	O2	R755	N10
C705	O10	Q605	D7	R756	N10
C706	P9	Q701	K11	R757	N10
C707	P11	Q702	K9	R758	P9
C708	N11	Q703	K7	R759	H11
C709	O10	Q704	H5	R760	I11
C710	P6	Q705	I5	R761	K8
C711	L9	Q706	I5	R762	K8
C712	L9	Q717	M6	R763	L8
C713	M9	Q712	P2	R764	L8
C715	O9	Q721	K6	R765	N8
C716	P7	Q722	L6	R766	N8
C718	L7	Q751	K10	R767	N8
C719	M7	Q752	K8	R768	N8
C720	M8	C720	M8	R769	O10
C722	N7	R102	B9	R778	P7
C723	P8	R109	B10	R780	H11
C724	H5	R110	B10	R781	J11
C725	I5	R159	B10	R782	N8
C727	M6	R160	B10	R783	L8
C729	J5	R400	B11	R785	P9
C731	O4	R401	B11	R786	P7
C732	N4	R450	B12	R787	H11
C734	H4	R451	B12	R788	H11
C735	L4	R602	D7	R789	K10
C736	K4	R604	D7	ZD701	N6
C740	M2	R607	C9		
C741	G3	R608	C8		
C743	G2	R609	C8		
C744	G3	R610	C8		
C745	H12	R611	D7		
C746	I11	R612	D7		
C747	J12	R613	D7		
C748	H2	R614	E7		
C751	L10	R615	D7		
C752	M10	R618	F9		
C753	M10	R623	F6		
C755	O10	R625	F6		
C756	P9	R626	F7		
C757	P11	R627	F3		
C761	L8	R629	E3		
C762	L8	R635	D11		
C763	M8	R637	D11		
C764	P5	R638	E3		
C765	N8	R639	D8		
C766	P7	R640	G8		
C777	O5	R641	O11		
C778	O4	R642	F11		
C779	N4	R643	H8		
C780	N5	R644	H7		
C782	P4	R645	D3		
C785	D3	R646	D3		
C796	I11	R655	D7		
C797	J11	R654	D7		

D.SCHEMATIC MAIN
03.5.08 SI4171

FRONT SCHEMATIC DIAGRAM

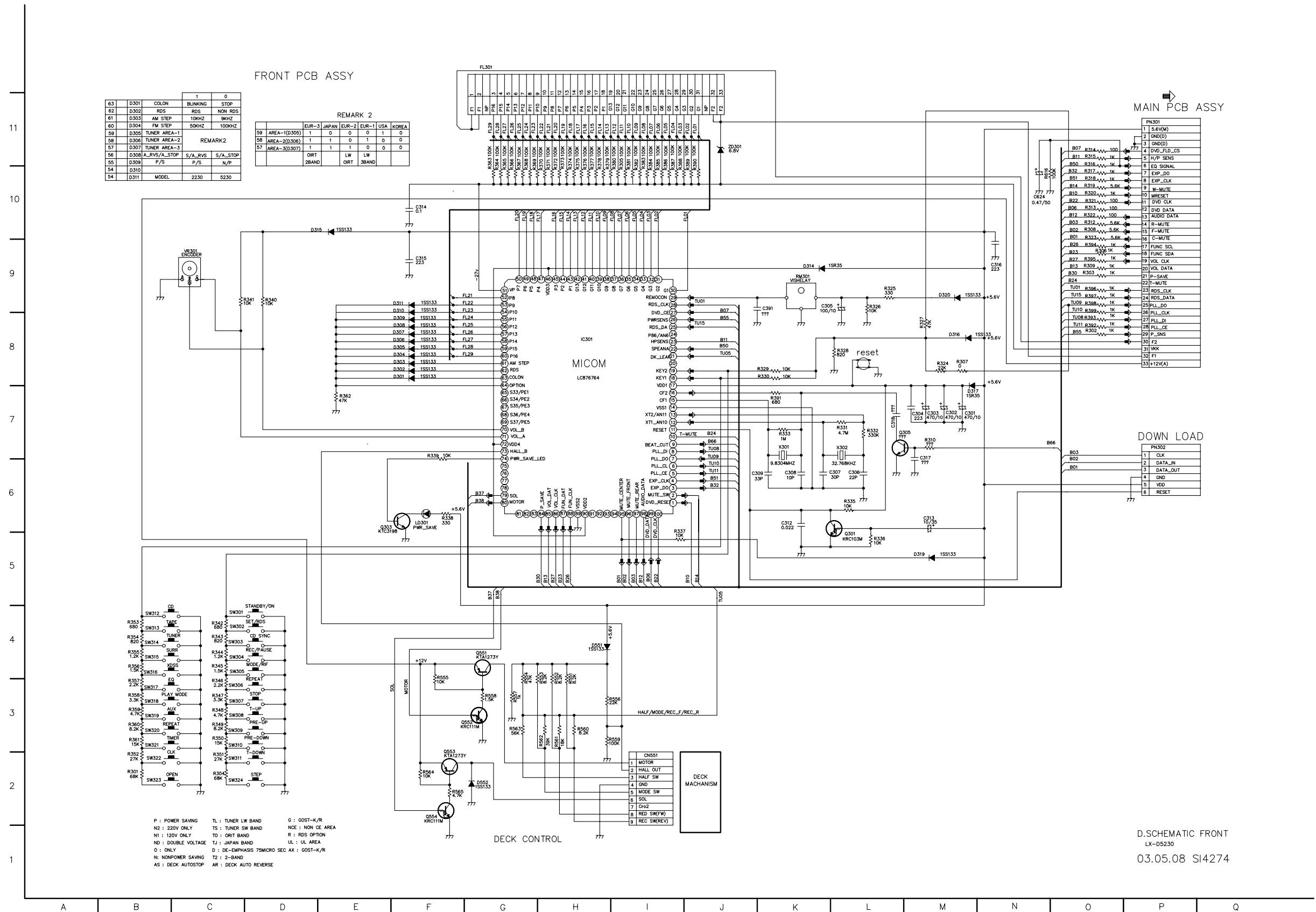

POWER SCHEMATIC DIAGRAM

NOTE: Warning
 Parts that are shaded are critical With respect to risk of fire or electrical shock.

NOTE:
 1. Shaded(■) parts are critical for safety. Replace only with specified part number.
 2. Voltages are DC-measured with a digital voltmeter during Play mode.

LOCATION GUIDE

C201	D9	Q902	M4
C202	D9	R201	D9
C203	E9	R202	E9
C204	E9	R203	E9
C205	F9	R204	E8
C206	F9	R205	F9
C208	G9	R207	F9
C209	H7	R208	G9
C210	E10	R209	H9
C211	C8	R210	E11
C212	B5	R211	C9
C213	C5	R212	B5
C214	D5	R213	C6
C215	E5	R214	C5
C216	E4	R215	E5
C217	F5	R216	E4
C218	F5	R217	E4
C219	F5	R218	F5
C220	G5	R219	G5
C221	G3	R220	G4
C222	D5	R221	D5
C223	D6	R222	D4
C224	A4	R223	D6
C225	B4	R224	D5
C226	B4	R225	C5
C227	C4	R226	C5
C228	C4	R227	A3
C229	C5	R228	C4
C230	D4	R229	D4
C231	C4	R230	D4
C251	D8	R251	D8
C252	E7	R252	E7
C253	E8	R253	E8
C254	E8	R254	E8
C255	F8	R255	F7
C256	F7	R257	F8
C258	G8	R258	G7
C262	B5	R259	H8
C263	C5	R262	B5
C264	D5	R263	B5
C265	E5	R264	C5
C267	F5	R265	E5
C268	F6	R266	F4
C269	F5	R268	F5
C270	G6	R269	G6
C551	H3	R270	G4
C733	L8	R550	I3
C901	M9	R551	I2
C902	M9	R552	J5
C912	L6	R553	J5
C913	M6	R555	J4
C914	L5	R556	J4
C915	M5	R557	J4
C917	L4	R901	M5
C918	M4	R902	M5
C919	N4	R903	M4
C920	P7	R904	M4
C950	N7	R905	M4
D551	I4	R906	O7
D900	M9	R907	O7
D904	M6	R908	L4
D905	M6	R900	P8
D906	M6	SW901	O8
D907	M5	T902	O6
D908	N4	ZD900	L5
D909	N4	ZD901	M4
D910	O7		
D911	P7		
D912	P8		
F901	P9		
F902	N9		
F903	N8		
F904	N8		
FB201	E9		
FB202	B5		
FB251	D7		
FB252	B5		
GND	Q10		
IC201	E9		
IC202	C6		
IC203	E6		
IC501	H3		
IC900	M6		
L201	C4		
OW900	N5		
OW901	P9		
OW909	P9		
OW910	O9		
OW911	O8		
OW912	O8		
OW920	O9		
OW922	O8		
OW923	O8		
OW924	O7		
OW931	O8		
OW932	O8		
Q201	H9		
Q202	C5		
Q203	B4		
Q204	D4		
Q205	D4		
Q251	H7		
Q252	F4		
Q501	J9		
Q901	P7		

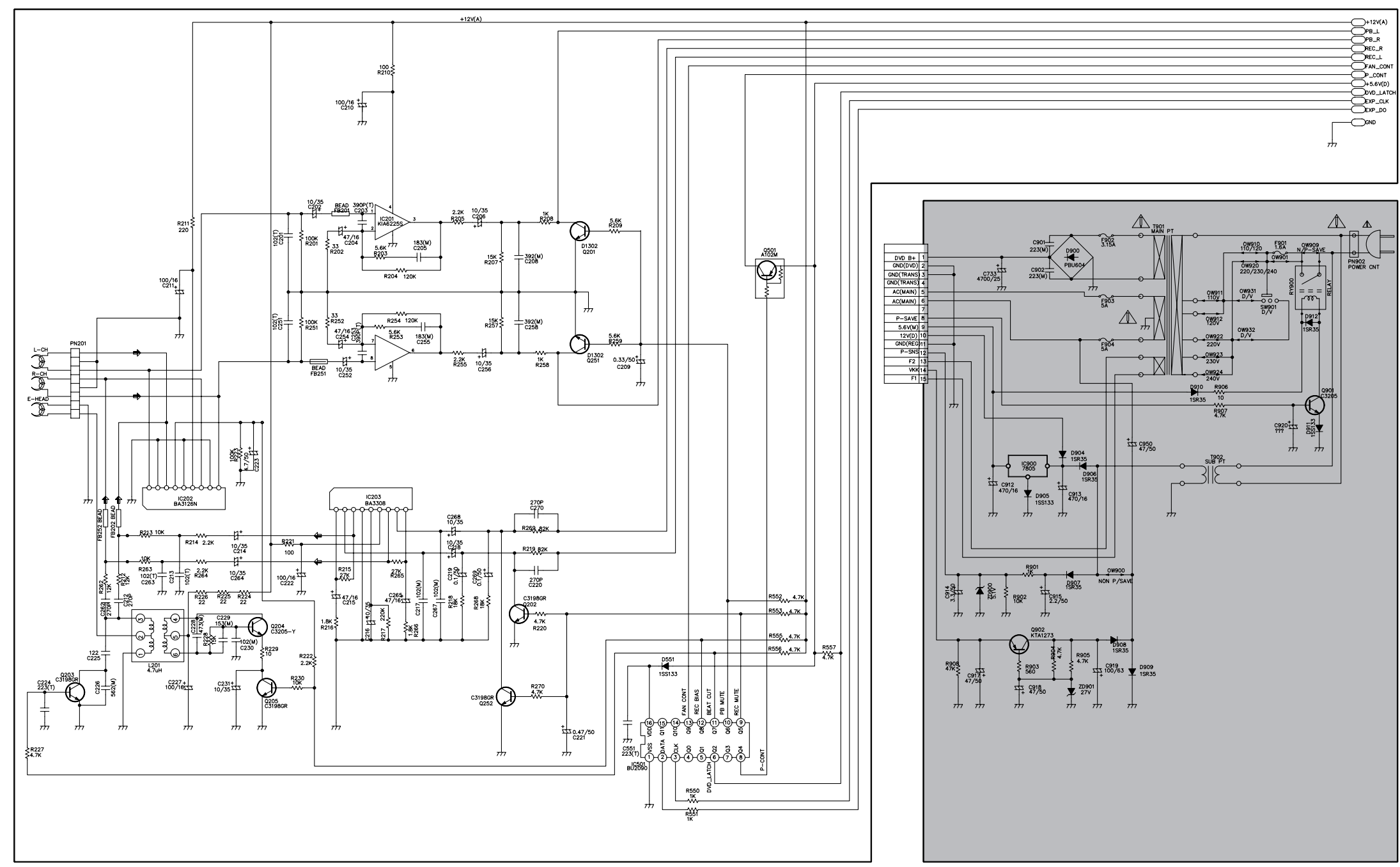

NO	SYMBOL	AUTOSHIP	AUTO-RYS
1	C225	182(PF)	122(PF)
2	C226	682(M)	562(M)
3	C224	X	223(T)
4	R212	47K	12K
5	R262	47K	12K

JACK/DECK
 03.05.08 SI4115
 LX-D5230

□ IC/TR VOLTAGE SHEET

IC	PIN NUM.	STOP	DVD PLAY	MIDI PLAY	
	1	-19.3	-19.3	-19.3	
IC701	2	-0.2	-0.2	-0.2	
IC702	3	19.0	19.0	19.0	
IC703	4	-18.4	-18.4	-18.4	
	5	7.7	7.7	7.7	
	6	-19.4	-19.4	-19.4	
	7	0.0	0.0	0.0	
	8	2.3	2.3	2.3	
	9	0.0	0.0	0.0	
	10	0.0	0.0	0.0	
	11	0.0	0.0	0.0	
	1	-11.5	-11.5	-11.5	
	IC712	2	-19.4	-19.4	-19.4
		3	0.0	0.0	0.0
1		0.0	0.0	0.0	
IC202	2	0.0	0.0	0.0	
	3	0.0	0.0	0.0	
	4	9.5	9.5	9.5	
	5	0.0	0.0	0.0	
	6	0.1	0.1	0.1	
	7	0.0	0.0	0.0	
	8	0.0	0.0	0.0	
	9	0.0	0.0	0.0	
	1	0.0	0.0	0.0	
IC201	2	1.3	1.3	1.3	
	3	0.7	0.7	0.7	
	4	3.4	3.4	3.4	
	5	0.0	0.0	0.0	
	6	11.4	11.4	11.4	
	7	3.5	3.5	3.5	
	8	1.7	1.7	1.7	
	9	1.3	1.3	1.3	
	1	1.8	1.8	1.8	
IC203	2	0.0	0.0	0.0	
	3	1.8	1.8	1.8	
	4	11.2	11.2	11.2	
	5	0.0	0.0	0.0	
	6	0.0	0.0	0.0	
	7	1.8	1.8	1.8	
	8	0.0	0.0	0.0	
	9	1.78	1.78	1.78	
	IC102	1	9.0	9.0	9.0
2		4.5	4.5	4.5	
3		4.5	4.5	4.5	
4		4.5	4.5	4.5	
5		4.5	4.5	4.5	
6		4.5	4.5	4.5	

IC	PIN NUM.	STOP	DVD PLAY	MIDI PLAY
	7	4.5	4.5	4.5
	8	0.0	0.0	0.0
	9	0.0	0.0	0.0
	10	0.0	0.0	0.0
	11	0.0	0.0	0.0
	12	0.0	0.0	0.0
	13	0.0	0.0	0.0
	14	4.5	4.5	4.5
	15	4.5	4.5	4.5
	16	4.5	4.5	4.5
	17	4.5	4.5	4.5
	18	4.5	4.5	4.5
	19	4.5	4.5	4.5
	20	4.5	4.5	4.5
IC501	1	0.0	0.0	0.0
	2	0.0	0.0	0.0
	3	0.0	0.0	0.0
	4	0.0	0.0	0.0
	5	0.0	0.0	0.0
	6	0.0	0.0	0.0
	7	0.0	0.0	0.0
	8	0.0	0.0	0.0
	9	4.4	4.4	4.4
	10	0.0	0.0	0.0
	11	0.0	0.0	0.0
	12	0.0	0.0	0.0
	13	2.4	2.4	2.4
	14	0.0	0.0	0.0
	15	0.0	0.0	0.0
	16	5.4	5.4	5.4
IC601	1	8.8	8.8	8.8
	2	4.4	4.4	4.4
	3	4.4	4.4	4.4
	4	4.4	4.4	4.4
	5	4.4	4.4	4.4
	6	4.4	4.4	4.4
	7	4.4	4.4	4.4
	8	4.4	4.4	4.4
	9	4.4	4.4	4.4
	10	4.4	4.4	4.4
	11	4.4	4.4	4.4
	12	4.4	4.4	4.4
	13	0.0	0.0	0.0
	14	0.0	0.0	0.0
	15	0.0	0.0	0.0
	16	4.4	4.4	4.4
	17	4.4	4.4	4.4

IC	PIN NUM.	STOP	DVD PLAY	MIDI PLAY
	18	4.4	4.4	4.4
	19	4.4	4.4	4.4
	20	4.4	4.4	4.4
	21	4.4	4.4	4.4
	22	4.4	4.4	4.4
	23	4.4	4.4	4.4
	24	4.4	4.4	4.4
	25	4.4	4.4	4.4
	26	4.4	4.4	4.4
	27	4.4	4.4	4.4
	28	0.0	0.0	0.0

WIRING DIAGRAM

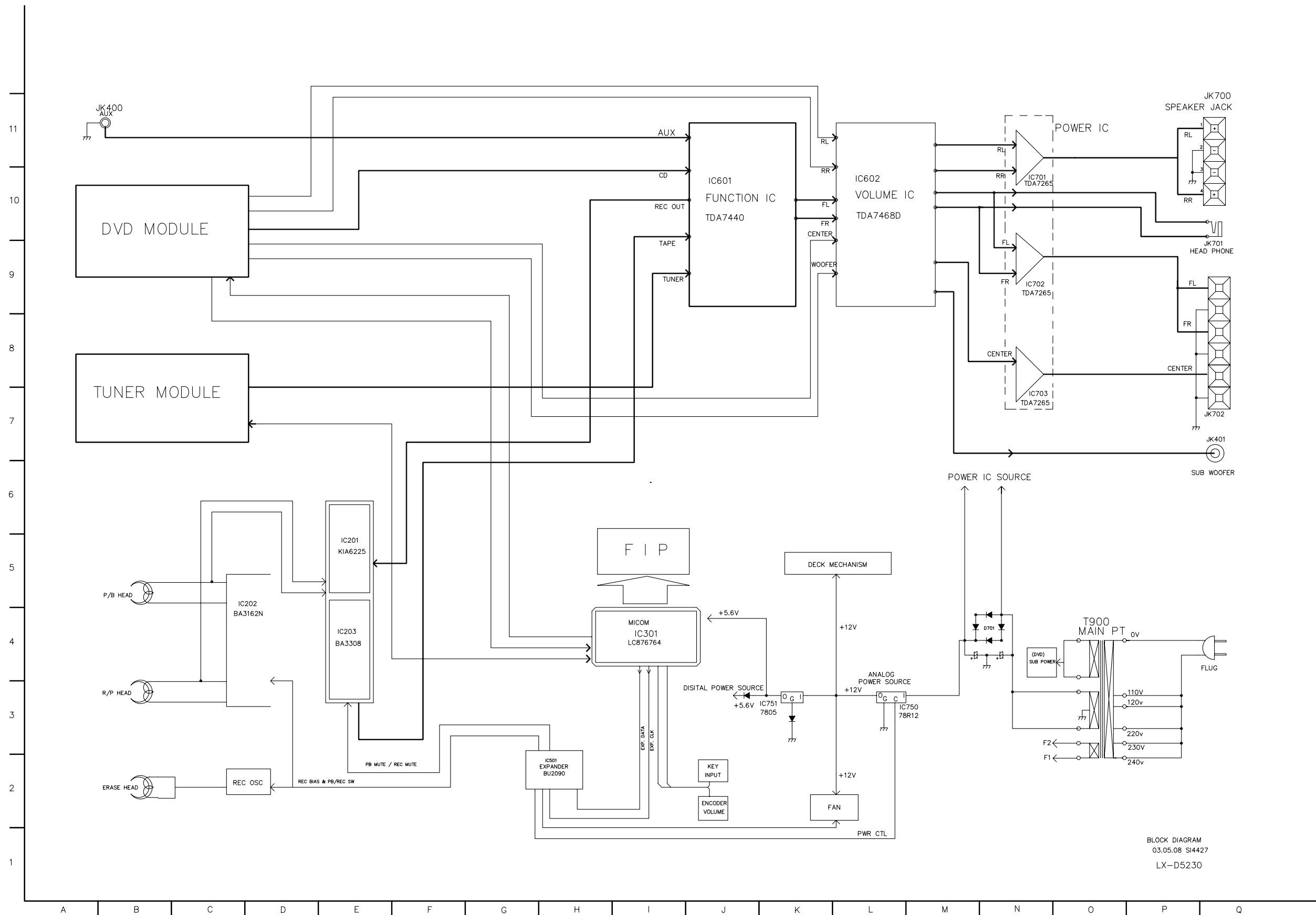

PRINTED CIRCUIT DIAGRAMS

MAIN P.C. BOARD(SOLDER SIDE)

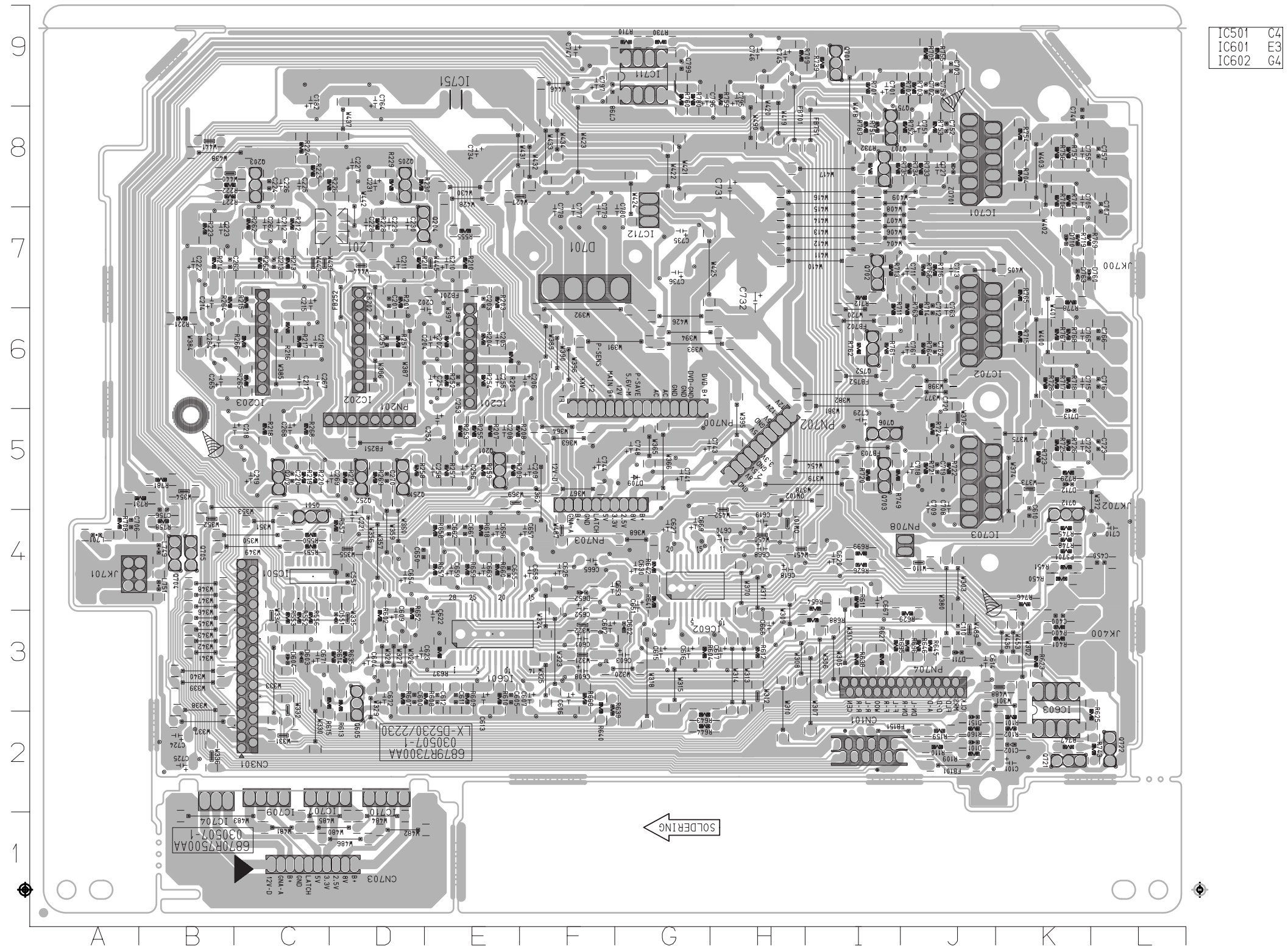

• MAIN P.C. BOARD(COMPONENT SIDE)

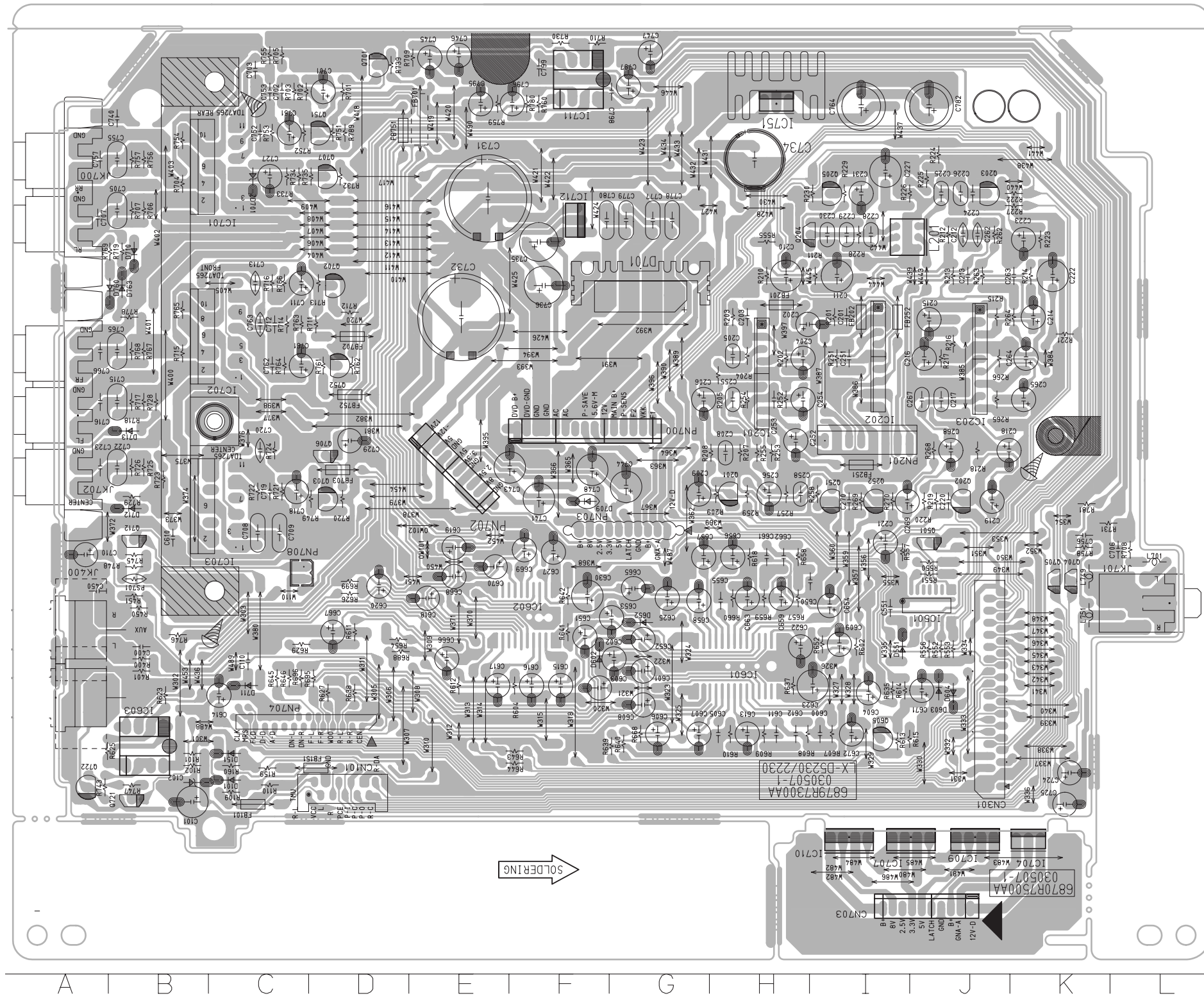

C101	B2	C607	G3	C723	A5	FB101	C2	Q707	D8	R401	B3	R710
C102	B2	C608	G3	C724	K2	FB151	D2	Q712	B4	R450	B4	R711
C110	C3	C609	I3	C725	K2	FB201	H7	Q721	B2	R451	B4	R712
C201	I7	C610	B4	C727	C8	FB202	I7	Q722	A2	R550	J4	R713
C202	H6	C611	H3	C729	D5	FB251	I5	Q751	D8	R551	J4	R714
C203	H7	C612	H3	C731	E8	FB252	I7	Q752	D6	R552	J3	R715
C204	H6	C613	H3	C732	E7	FB701	E8	R101	B2	R553	J3	R716
C205	H6	C614	C3	C734	H8	FB702	D6	R102	B2	R555	H7	R717
C206	G6	C615	F3	C735	F7	FB703	D5	R109	C2	R556	J3	R718
C208	H5	C616	F3	C736	F7	FB751	D8	R110	C2	R557	I4	R719
C209	G5	C617	E3	C740	B8	FB752	D6	R159	C2	R602	I3	R720
C210	H7	C618	E4	C741	F5	IC201	H6	R160	C2	R604	F3	R721
C211	I7	C619	E4	C743	F5	IC202	I7	R201	I7	R607	I3	R722
C212	J7	C620	D4	C744	G5	IC203	J7	R202	H6	R608	H3	R723
C213	J7	C622	H3	C745	E9	IC603	B3	R203	H7	R609	H3	R724
C214	K7	C623	I3	C746	E9	IC701	C8	R204	H6	R610	H3	R725
C215	J7	C625	G4	C747	G9	IC702	C6	R205	H6	R611	D4	R726
C216	J6	C627	F4	C748	F5	IC703	C4	R207	H5	R612	E3	R728
C217	J6	C630	F4	C751	C8	IC704	K2	R208	H5	R613	I3	R729
C218	J5	C650	I4	C752	C8	IC707	J2	R209	H5	R614	I3	R730
C219	J5	C651	F4	C753	C9	IC709	J2	R210	H7	R615	I3	R731
C220	J5	C652	G4	C755	B8	IC710	I2	R211	I7	R618	H4	R732
C221	I4	C653	G4	C756	K4	IC711	F9	R212	J7	R623	B3	R733
C222	K7	C654	I4	C757	A8	IC712	F7	R213	J7	R625	A2	R734
C223	K7	C655	H4	C761	C6	IC751	H9	R214	K7	R626	D4	R735
C224	J8	C656	H4	C762	C6	JK400	A4	R215	J7	R627	D3	R739
C225	J8	C657	G4	C763	C6	JK401	A3	R216	J6	R629	C3	R743
C226	J8	C658	G4	C764	I9	JK700	A8	R217	J6	R635	I3	R745
C227	I8	C659	H4	C765	B6	JK701	L4	R218	J5	R637	H3	R746
C228	I7	C661	H4	C766	A6	JK702	A6	R219	J5	R638	D3	R747
C229	I7	C662	H4	C777	G7	L201	I7	R220	J5	R639	G3	R748
C230	I7	C663	H4	C778	G7	L701	L4	R221	K6	R640	G3	R749
C231	I8	C665	G4	C779	G7	L749	K4	R222	K8	R641	F4	R751
C251	I6	C666	E3	C780	F7	L751	K4	R223	K7	R642	F4	R752
C252	H5	C667	D4	C782	J9	OW101	E4	R224	J8	R643	F2	R753
C253	H6	C668	E4	C795	E9	OW102	E5	R225	J8	R644	F2	R754
C254	H6	C669	F4	C796	F9	PN201	I5	R226	J8	R645	C3	R755
C255	H6	C670	E4	C797	G9	PN700	F5	R227	K8	R646	C3	R756
C256	H5	C671	J3	C798	G9	PN702	E5	R228	I7	R652	I3	R757
C258	H5	C672	I3	C799	F9	PN703	G5	R229	I8	R654	D4	R758
C262	J7	C701	D9	CN101	C2	PN704	C3	R230	I8	R657	H4	R759
C263	K7	C702	C9	CN301	J2	PN708	C4	R251	I6	R658	H4	R760
C264	K6	C703	C9	CN703	J1	PS701	B4	R252	H6	R659	H4	R761
C265	K6	C705	B8	D101	C2	Q201	H5	R253	H5	R660	H4	R762
C267	J6	C706	L4	D151	C2	Q202	J5	R254	H6	R668	G3	R763
C268	J5	C707	A7	D551	I3	Q203	J8	R255	H5	R688	D3	R764
C269	I5	C708	C5	D602	F3	Q204	I7	R257	H5	R695	D3	R765
C270	I5	C709	C5	D603	J3	Q205	I8	R258	I5	R696	C3	R766
C400	B3	C710	A4	D604	J3	Q251	I5	R259	H5	R699	D4	R767
C450	A4	C711	C7	D652	G4	Q252	I5	R262	J7	R701	D9	R768
C551	I4	C712	C6	D701	G7	Q501	J4	R263	J7	R702	C9	R769
C600	I3	C713	C7	D709	F5	Q605	I3	R264	K7	R703	C9	R778
C601	G3	C715	B6	D710	B7	Q701	D9	R265	J6	R704	B8	R780
C602	G3	C716	A6	D711	C3	Q702	D7	R266	J6	R705	C9	R781
C603	F3	C718	C5	D712	B5	Q703	D5	R268	J5	R706	B8	R789
C604	I3	C719	C5	D713	B5	Q704	K4	R269	I5	R707	B8	ZD701
C605	H3	C720	C5	D760	B7	Q705	K4	R270	I5	R708	L4	
C606	G3	C722	B5	D763	B7	Q706	D5	R400	B3	R709	E9	

• FRONT P.C. BOARD (SOLDER SIDE)

NOTE: Warning
 ⚠ Parts that are shaded are critical With respect to risk of fire or electrical shock.

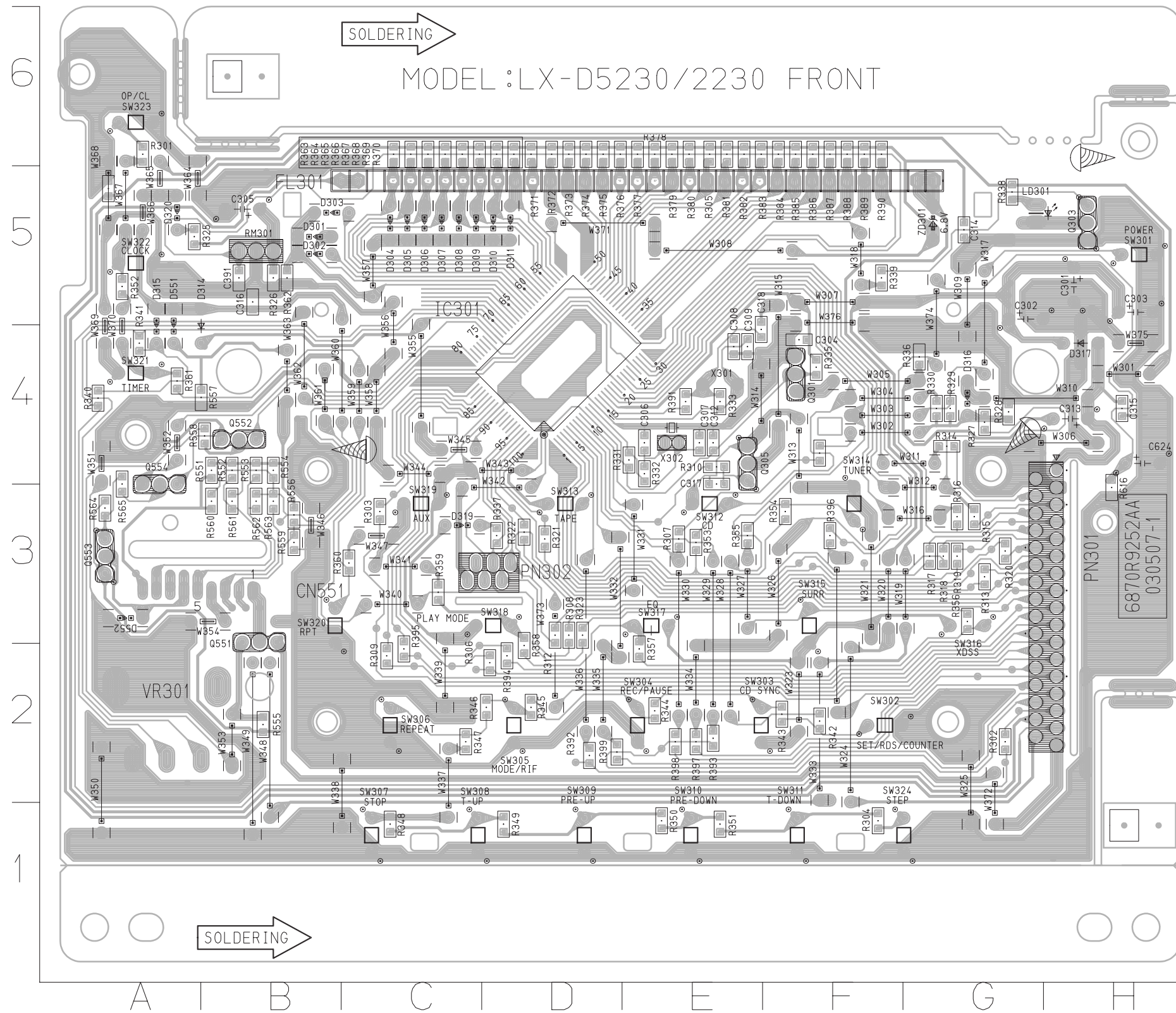

C304	F4	R331	E4	R375	D6
C306	E4	R332	E4	R376	D6
C307	E4	R333	E4	R377	E6
C308	E4	R335	F4	R378	E6
C309	E4	R336	G4	R379	E6
C312	E4	R337	D3	R380	E6
C314	G5	R338	G5	R381	E6
C315	H4	R339	F5	R382	E6
C316	B5	R340	A4	R383	E6
C317	E3	R341	A4	R384	F6
C318	E4	R342	F2	R385	F6
C391	B5	R343	F2	R386	F6
IC301	D4	R344	E2	R387	F6
		R345	D2	R388	F6
		R346	D2	R389	F6
R301	A6	R347	C2	R390	F6
R302	G2	R348	C1	R391	E4
R303	C3	R349	D1	R392	D2
R304	F1	R350	E1	R393	E2
R305	E6	R351	E1	R394	D2
R306	D2	R352	A5	R395	C2
R307	E3	R353	E3	R396	F3
R308	D3	R354	F3	R397	E2
R309	C2	R355	E3	R398	E2
R310	E4	R356	G3	R399	D2
R312	D3	R357	E2	R551	B4
R313	G3	R358	D2	R552	B4
R314	G4	R359	C3	R553	B4
R315	G3	R360	C3	R554	B4
R316	G3	R361	A4	R555	B2
R317	G3	R362	B5	R556	B3
R318	G3	R363	C6	R557	B4
R319	G3	R364	C6	R558	B4
R320	G3	R365	C6	R559	B3
R321	D3	R366	C6	R560	B3
R322	D3	R367	C6	R561	B3
R323	D3	R368	C6	R562	B3
R324	F4	R369	D6	R563	B3
R325	A5	R370	D6	R564	A3
R326	B5	R371	D6	R565	A3
R327	G4	R372	D6	R616	H3
R328	G4	R373	D6		
R329	G4	R374	D6		
R330	G4				

• FRONT P.C. BOARD (COMPONENT SIDE)

NOTE: Warning
 Parts that are shaded are critical With respect to risk of fire or electrical shock.

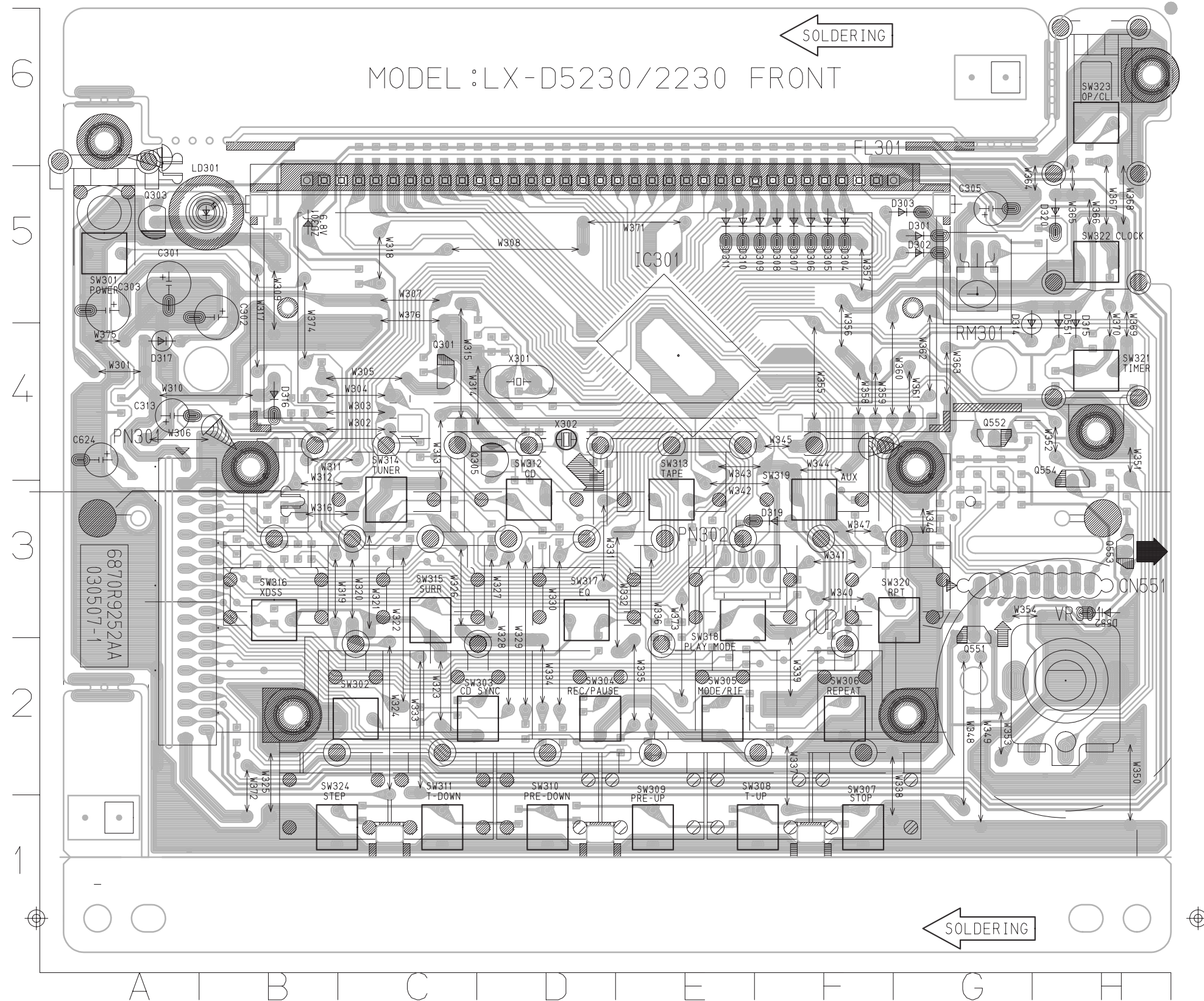

C301	A5	Q551	G3
C302	B5	Q552	G4
C303	A5	Q553	H3
C305	G5	Q554	H3
C313	A4	RM301	G5
C624	A4	SW301	A5
CN551	G3	SW302	C2
D301	G5	SW303	D2
D302	G5	SW304	D2
D303	G5	SW305	E2
D304	F5	SW306	F2
D305	F5	SW307	F1
D306	F5	SW308	F1
D307	F5	SW309	E1
D308	F5	SW310	D1
D309	F5	SW311	C1
D310	E5	SW312	D3
D311	E5	SW313	E3
D314	G4	SW314	C3
D315	H4	SW315	C3
D316	B4	SW316	B3
D317	A4	SW317	D3
D319	F3	SW318	E3
D320	H5	SW319	F3
D551	H4	SW320	G3
D552	H3	SW321	H4
FL301	G5	SW322	H5
LD301	B5	SW323	H6
PN301	A4	SW324	B1
PN302	E3	VR301	H2
Q301	C4	X301	D4
Q303	A5	X302	D4
Q305	D4	ZD301	B5

□ DVD PART SCHEMATIC DIAGRAMS

• MPEG SCHEMATIC DIAGRAM

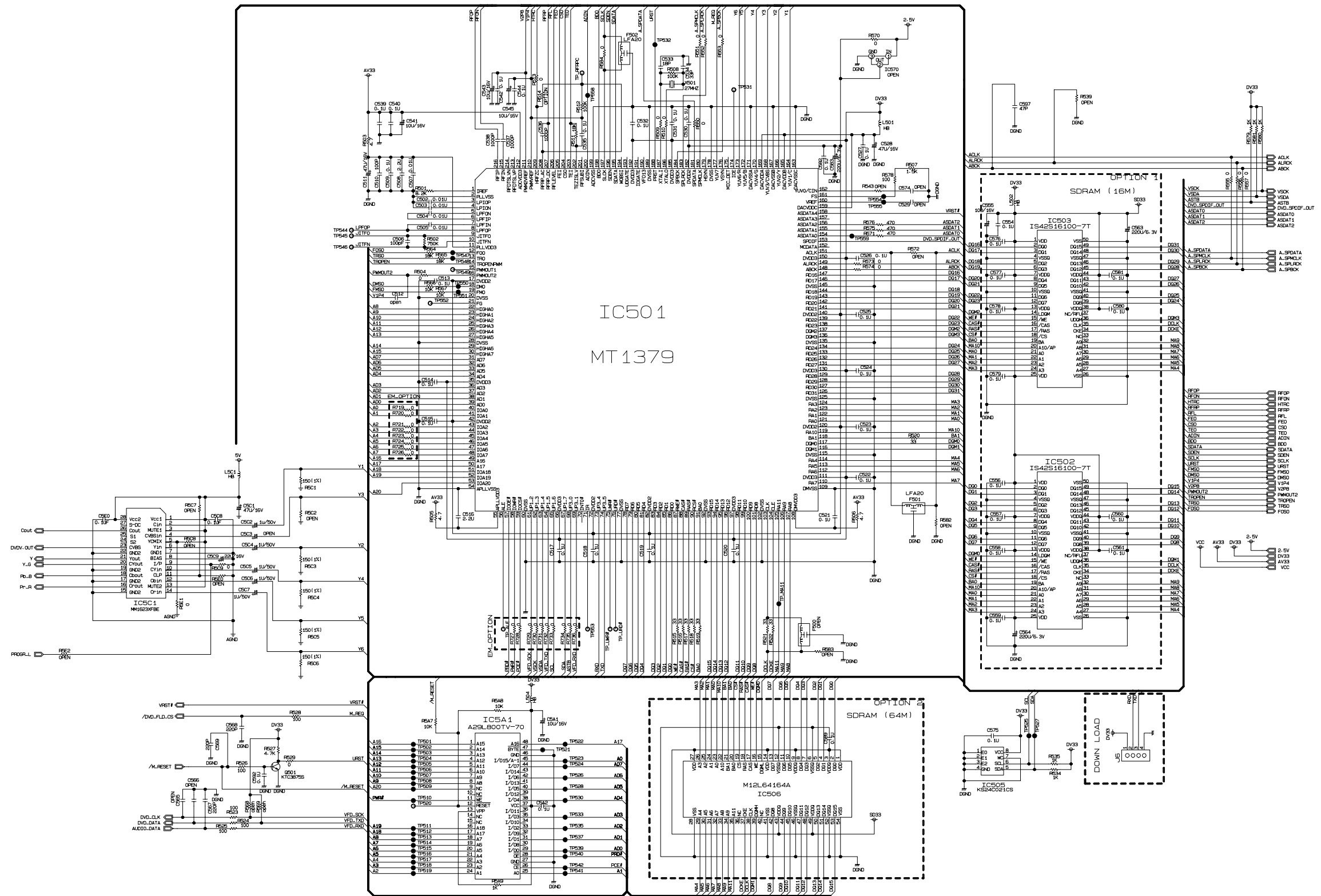

• AUDIO SCHEMATIC DIAGRAM

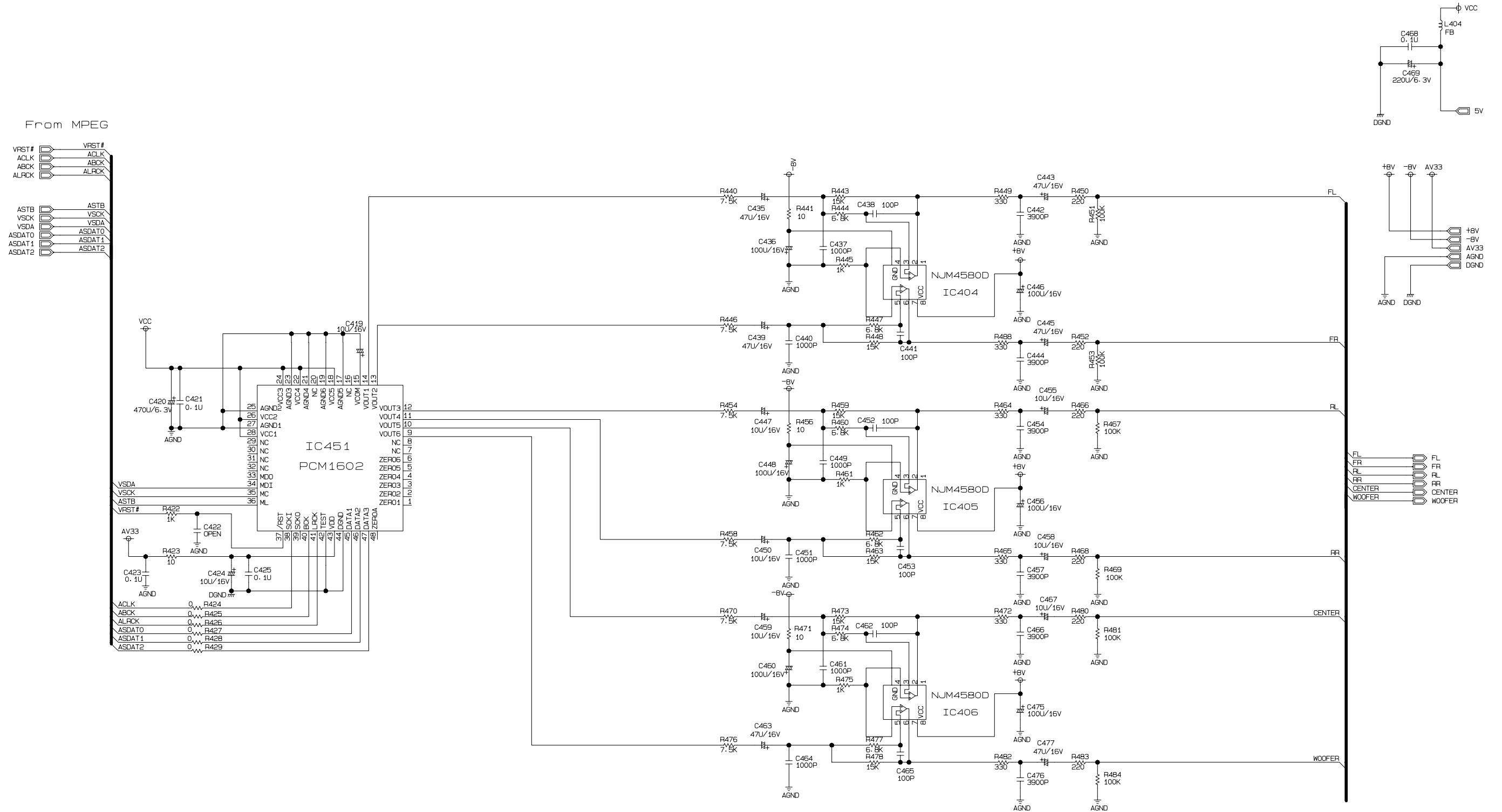

• INTERFACE SCHEMATIC DIAGRAM

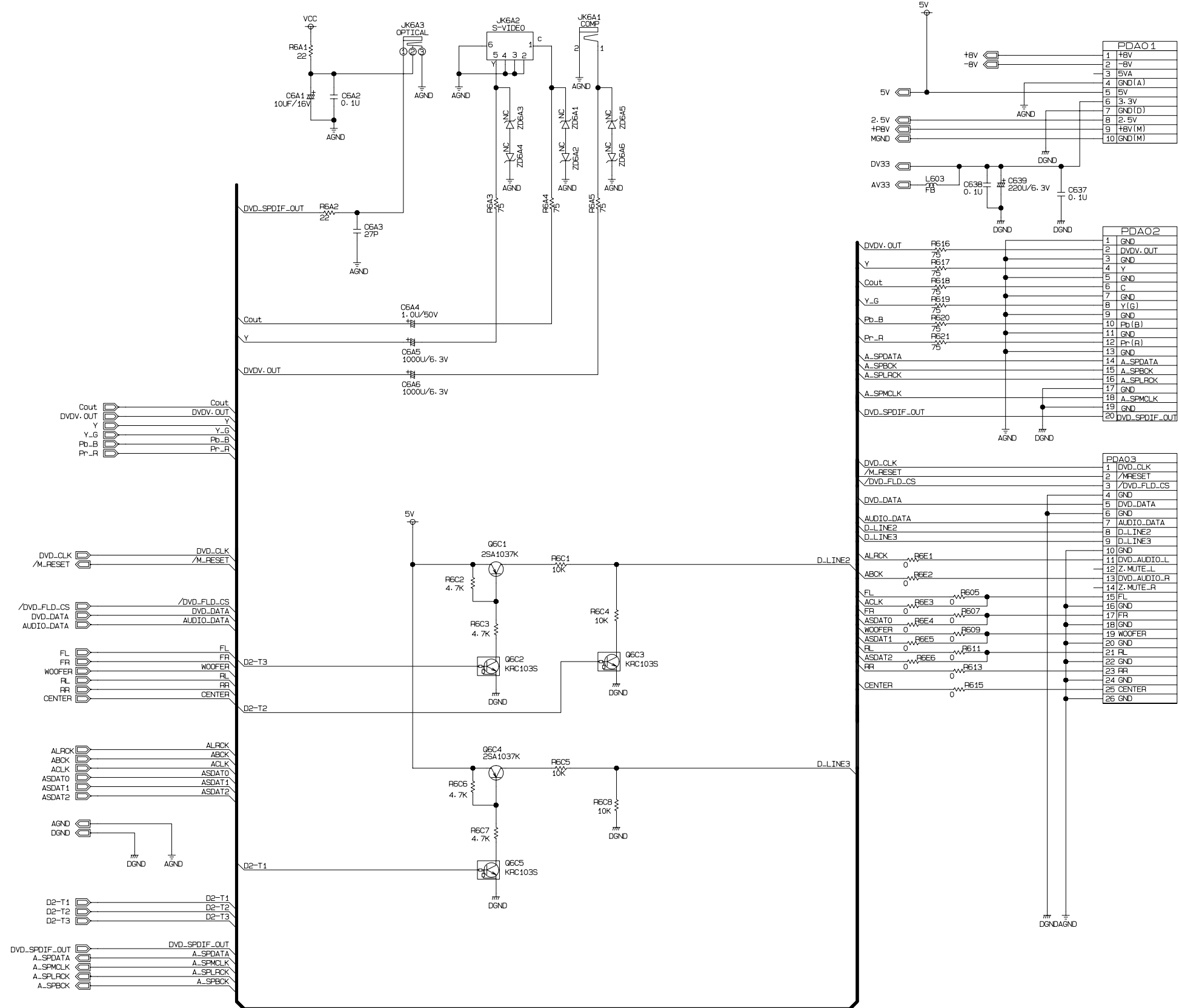

PRINTED CIRCUIT DIAGRAM

DVD P.C. BOARD(SOLDER SIDE)

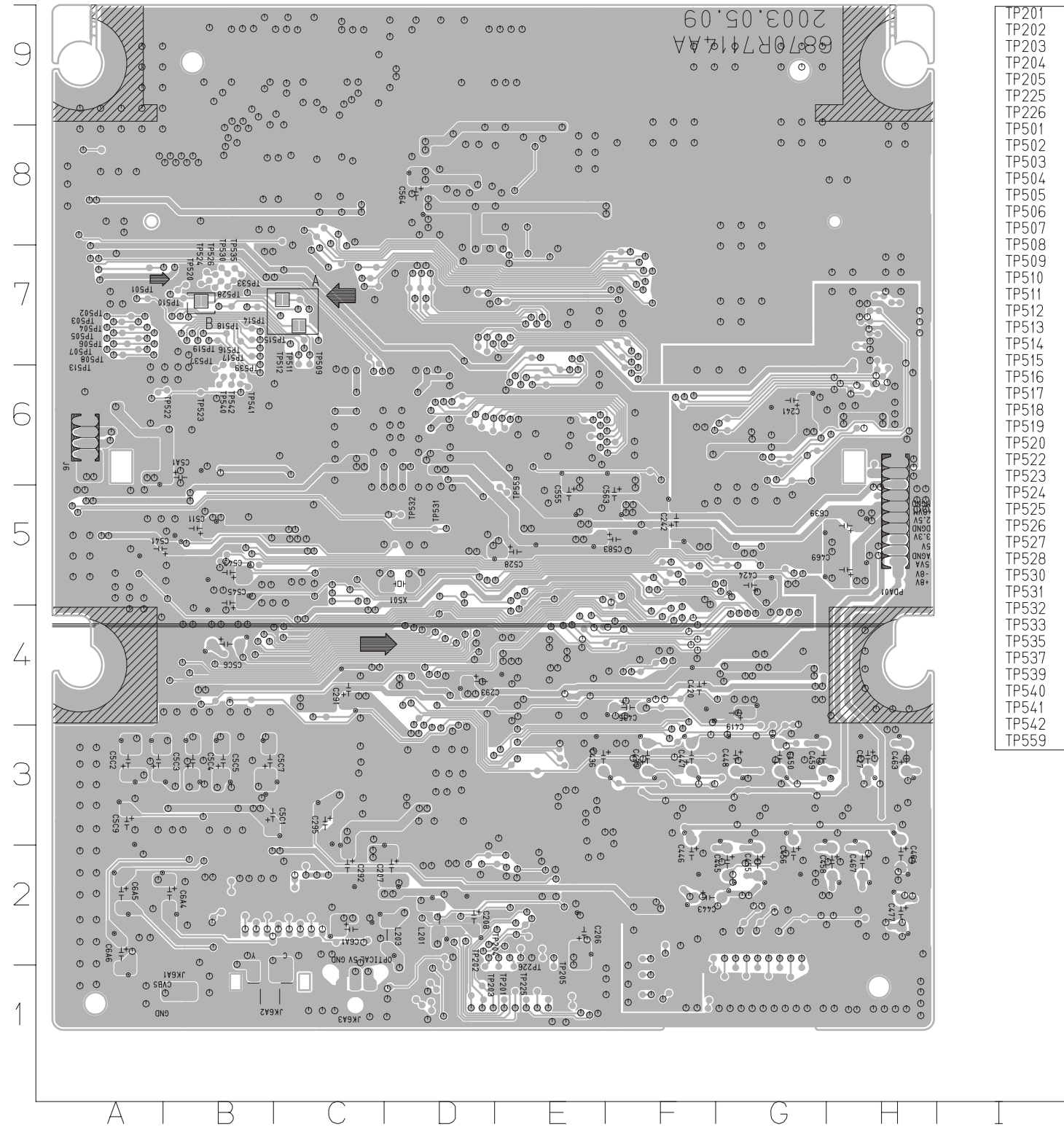

• DVD P.C. BOARD (COMPONENT SIDE)

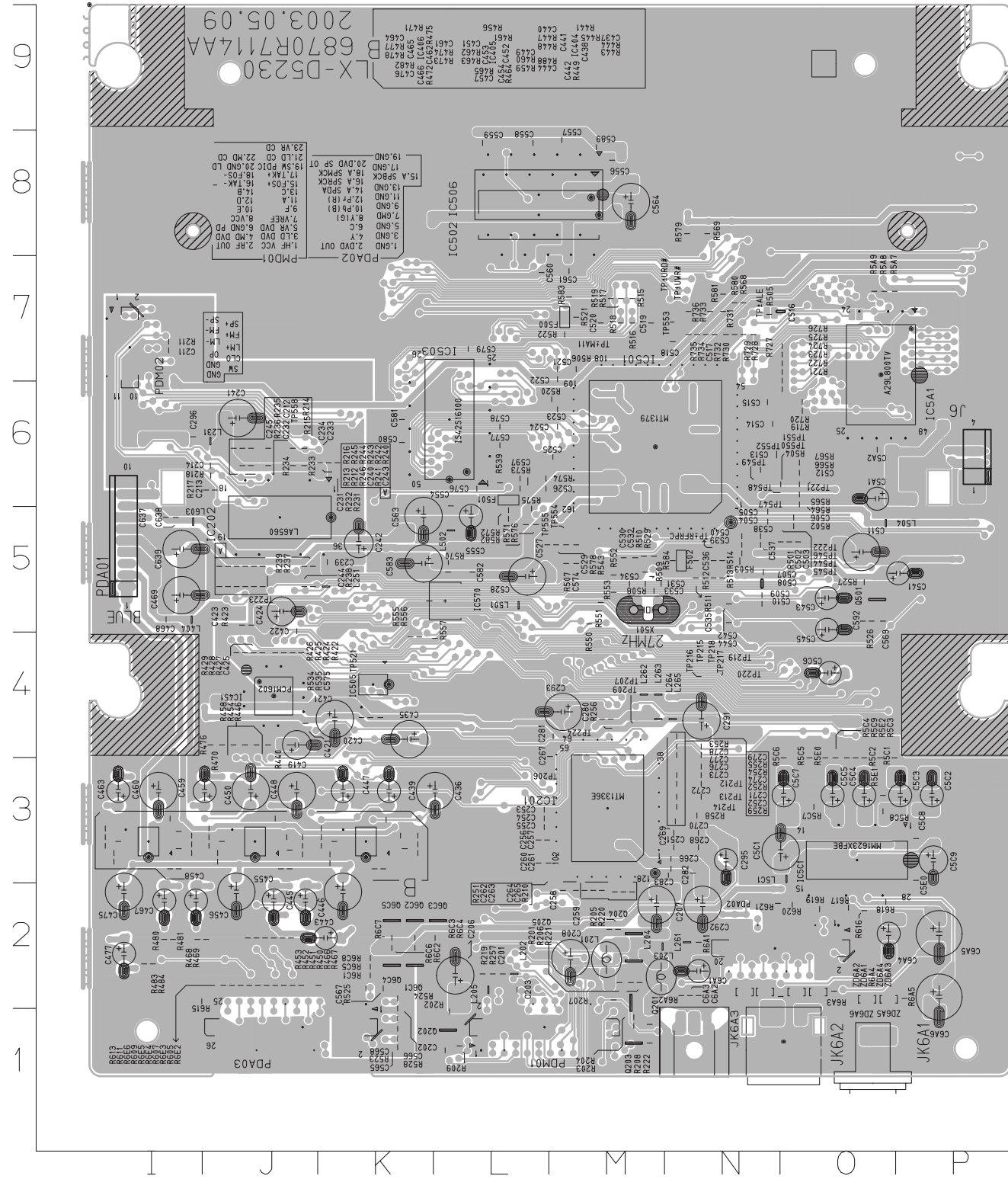

C201	L2	C435	K4	C529	M5	C6A6	P2	R210	M2	R462	J3	R566	O6	R720	O6
C202	L1	C436	L3	C530	M5	F500	M7	R211	I7	R463	J3	R567	O6	R721	O6
C203	L2	C437	K3	C531	M5	F501	L6	R212	J5	R464	J3	R568	N7	R722	O6
C206	L2	C438	K3	C532	M5	F502	N5	R213	J5	R465	J3	R569	N8	R723	O7
C207	M2	C439	K3	C533	M5	IC201	M3	R214	J6	R466	J2	R570	L5	R724	O7
C208	M2	C440	K3	C534	M5	IC202	J5	R215	J6	R467	J2	R571	L5	R725	O7
C211	I7	C441	K3	C535	N5	IC404	K3	R216	J5	R468	I2	R572	L5	R726	O7
C212	J6	C442	K3	C536	N5	IC405	J3	R217	J6	R469	J2	R573	L6	R727	N7
C213	J6	C443	K2	C537	N5	IC406	I3	R218	J6	R470	J4	R574	L6	R728	N7
C214	J6	C444	K3	C538	N5	IC451	J4	R219	L2	R471	I3	R575	L5	R729	N7
C231	K6	C445	J2	C539	N5	IC501	M6	R220	M2	R472	I3	R576	L5	R730	N7
C232	J6	C446	K2	C540	N5	IC502	L8	R221	M1	R473	I3	R578	M5	R731	N7
C233	J6	C447	K3	C541	P5	IC503	L6	R222	M1	R474	I3	R579	N8	R732	N7
C234	J6	C448	J3	C542	N5	IC505	K4	R231	K6	R475	I3	R580	N7	R733	N7
C239	K5	C449	J3	C543	O5	IC506	L8	R232	K6	R476	J4	R581	N7	R734	N7
C240	J5	C450	J3	C544	N5	IC570	L5	R233	J6	R477	I3	R582	L5	R735	N7
C241	J6	C451	J3	C545	O5	IC5A1	O7	R234	J6	R478	I3	R583	M7	R736	N7
C242	K5	C452	J3	C554	L6	IC5C1	O3	R235	J6	R480	I2	R584	N5	TP206	M3
C243	J5	C453	J3	C555	L5	J6	P6	R236	J6	R481	I2	R5A7	O7	TP207	M4
C244	J5	C454	J3	C556	M8	JK6A1	O1	R237	J5	R482	I3	R5A8	O7	TP209	M3
C245	J6	C455	J2	C557	M8	JK6A2	O1	R238	J5	R483	I2	R5A9	O7	TP212	N3
C251	N3	C456	J2	C558	L8	JK6A3	N1	R239	J5	R484	I2	R5C1	O3	TP213	N3
C252	N3	C457	J3	C559	L8	L201	M2	R240	J5	R488	K3	R5C2	O3	TP214	N3
C253	L3	C458	I2	C560	L7	L202	L2	R241	J5	R501	O5	R5C3	O3	TP215	N4
C254	L3	C459	J3	C561	M7	L203	M2	R242	J5	R502	O5	R5C4	O3	TP216	N4
C255	L3	C460	I3	C563	K5	L204	M2	R243	J5	R503	N5	R5C5	O3	TP217	N4
C256	L3	C461	I3	C564	M8	L205	L2	R244	J5	R504	O6	R5C6	O3	TP218	N4
C257	L3	C462	I3	C565	K1	L231	J6	R245	J5	R505	N7	R5C7	O3	TP219	N4
C258	M2	C463	I3	C566	K1	L251	K5	R246	J5	R506	M7	R5C8	O3	TP220	N4
C259	M2	C464	I3	C567	K2	L261	N2	R251	M2	R507	M5	R5C9	O3	TP221	O6
C260	L3	C465	I3	C568	K1	L262	M4	R252	N3	R508	M5	R5E0	O3	TP222	O5
C261	L3	C466	I3	C569	O5	L263	M4	R253	N4	R509	M5	R5E1	O3	TP223	J5
C262	M2	C467	I2	C574	M5	L264	M4	R254	N4	R510	M5	R5E2	O3	TP224	M4
C263	M2	C468	I5	C575	K4	L265	N4	R255	N4	R511	M5	R605	J2	TP521	K4
C264	M2	C469	I5	C576	L6	L404	I5	R256	M4	R512	N5	R607	J2	TP544	O5
C265	M2	C475	I2	C577	L6	L501	L5	R257	L2	R513	N5	R609	J2	TP545	O5
C266	N3	C476	I3	C578	L6	L502	L5	R258	N3	R514	N5	R611	J2	TP546	O5
C267	M4	C477	I2	C579	L7	L504	O5	R259	N3	R515	M7	R613	J2	TP547	N6
C268	N3	C502	O5	C580	K6	L5C1	O3	R422	J4	R516	M7	R615	I2	TP548	O6
C269	N3	C503	O5	C581	K6	L603	I5	R423	J5	R517	M7	R616	O2	TP549	N6
C270	N3	C504	N5	C582	L5	PDA01	I5	R424	J4	R518	M7	R617	O2	TP550	O6
C271	N3	C505	N5	C583	K5	PDA02	N2	R425	J4	R519	M7	R618	O2	TP551	O6
C272	N3	C506	O5	C589	M8	PDA03	J1	R426	J4	R520	M6	R619	O2	TP552	N6
C273	N3	C507	N5	C592	O5	PDM01	L1	R427	J4	R521	M7	R620	O2	TP553	N7
C274	N3	C508	N5	C597	L6	PDM02	I7	R428	J4	R522	M7	R621	N2	TP554	M5
C276	N3	C509	N5	C5A1	O6	Q201	M2	R429	J4	R523	K1	R6A1	N2	TP555	M5
C277	N3	C510	N5	C5A2	O6	Q202	L1	R440	J4	R524	K2	R6A2	N2	TP558	J6
C278	N4	C511	O5	C5C1	O3	Q203	M1	R441	K3	R525	K2	R6A3	O2	TP±ALE	N7
C279	N4	C512	O6	C5C2	P3	Q204	M2	R443	K3	R526	O5	R6A4	O2	TP±MA11	M7
C280	M4	C513	N6	C5C3	P3	Q205	M2	R444	K3	R527	O5	R6A5	P2	TP±RFRP	N5
C281	M4	C514	N6	C5C4	O3	Q501	O5	R445	K3	R528	K1	R6C1	K2	TP±URD#	N7
C282	N3	C515	N6	C5C5	O3	Q6C1	K2	R446	J4	R529	M5	R6C2	K2	TP±UWR#	N7
C283	N3	C516	O7	C5C6	O4	Q6C2	K2	R447	K3	R534	K4	R6C3	K2	X501	M5
C291	N4	C517	N7	C5C7	O3	Q6C3	L2	R448	K3	R535	K4	R6C4	L2	ZD6A1	N2
C292	N2	C518	N7	C5C8	P3	Q6C4	K2	R449	K3	R539	L6	R6C5	K2	ZD6A2	N2
C293	M4	C519	M7	C5C9	P3	Q6C5	K2	R450	J2	R543	M5	R6C6	K2	ZD6A3	O2
C295	N3	C520	M7	C5E0	P3	R201	M2	R451	J2	R550	M5	R6C7	K2	ZD6A4	O2
C296	I6	C521	M7	C637	I5	R202	L1	R452	J2	R551	M5	R6C8	K2	ZD6A5	O2
C419	J4	C522	M7	C638	I5	R203	M1	R453	J2	R552	M5	R6E1	K2	ZD6A6	O2
C420	K4	C523	M6	C639	I5	R204	M1	R454	J4	R553	M5	R6E2	J2		
C421	J4	C524	M6	C6A1	N2	R205	M2	R456	J3	R555	K4	R6E3	J2		
C422	J5	C525	M6	C6A2	N2	R206	M2	R458	J4	R556	K4	R6E4	J2		
C423	J5	C526	L6	C6A3	N2	R207	M2	R459	J3	R557	L4	R6E5	J2		
C424	J5	C527	L5	C6A4	O2	R208	M1	R460	J3	R564	O6	R6E6	J2		
C425	J4	C528	L5	C6A5	P2	R209	L1	R461	J3	R565	O6	R719	O6		

SECTION 4. EXPLODED VIEWS

□ CABINET AND MAIN FRAME SECTION

NOTE) Refer to "SECTION 6 REPLACEMENT PARTS LIST" in order to look for the part number of each part.

