

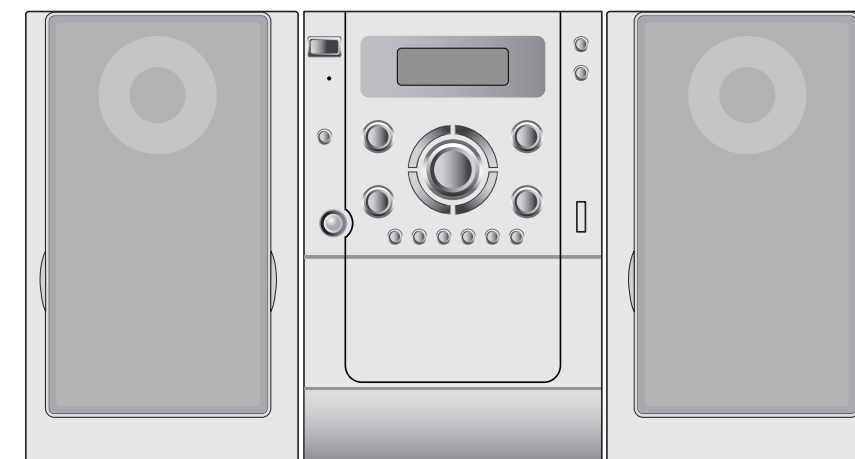

SERVICE MANUAL

MODEL : LX-U150X(LXU-150)

# MICRO COMPONENT SYSTEM SERVICE MANUAL



MODEL : LX-U150X (LXS-U150)

# [CONTENTS]

## ○ SECTION 1. GENERAL

- SERVICING PRECAUTIONS ..... 1-2
- ESD PRECAUTIONS ..... 1-4
- SPECIFICATION ..... 1-5

## ○ SECTION 2. ELECTRICAL

- ADJUSTMENTS ..... 2-1
- WAVEFORMS OF MAJOR CHECK POINT ..... 2-2
- TROUBLESHOOTING ..... 2-5
- BLOCK DIAGRAM ..... 2-23
- SCHEMATIC DIAGRAMS ..... 2-25
- WIRING DIAGRAM ..... 2-33
- PRINTED CIRCUIT DIAGRAMS ..... 2-35
- INTERNAL BLOCK DIAGRAM OF ICs ..... 2-43

## ○ SECTION 3. EXPLODED VIEWS

- CABINET AND MAIN FRAME SECTION ..... 3-1

## ○ SECTION 4. SPEAKER ..... 4-1

## ○ SECTION 5. REPLACEMENT PARTS LIST

- REPLACEMENT PARTS LIST ..... 5-1

# SECTION 1. GENERAL

## □ SERVICING PRECAUTIONS

### NOTES REGARDING HANDLING OF THE PICK-UP

#### 1. Notes for transport and storage

- 1) The pick-up should always be left in its conductive bag until immediately prior to use.
- 2) The pick-up should never be subjected to external pressure or impact.

Storage in conductive bag

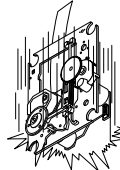
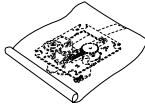

Drop impact

#### 2. Repair notes

- 1) The pick-up incorporates a strong magnet, and so should never be brought close to magnetic materials.
- 2) The pick-up should always be handled correctly and carefully, taking care to avoid external pressure and impact. If it is subjected to strong pressure or impact, the result may be an operational malfunction and/or damage to the printed-circuit board.
- 3) Each and every pick-up is already individually adjusted to a high degree of precision, and for that reason the adjustment point and installation screws should absolutely never be touched.
- 4) Laser beams may damage the eyes!  
Absolutely never permit laser beams to enter the eyes!  
Also NEVER switch ON the power to the laser output part (lens, etc.) of the pick-up if it is damaged.

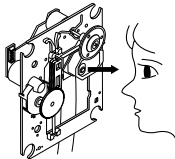

NEVER look directly at the laser beam, and don't let contact fingers or other exposed skin.

#### 5) Cleaning the lens surface

If there is dust on the lens surface, the dust should be cleaned away by using an air bush (such as used for camera lens). The lens is held by a delicate spring. When cleaning the lens surface, therefore, a cotton swab should be used, taking care not to distort this.

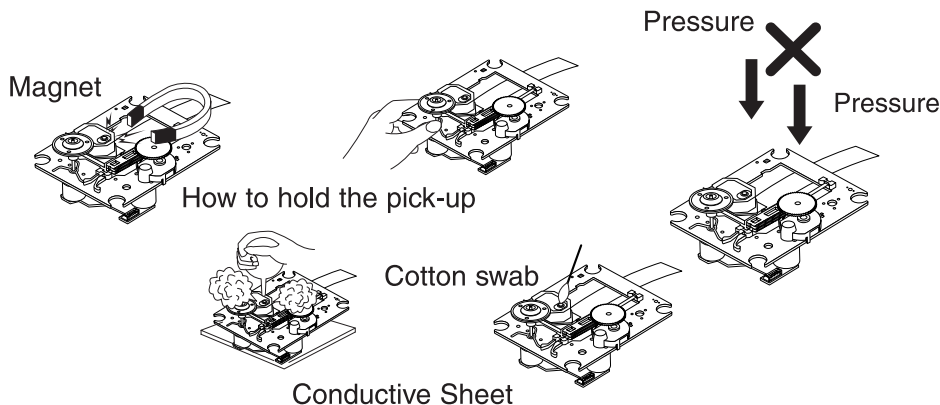

#### 6) Never attempt to disassemble the pick-up.

Spring by excess pressure. If the lens is extremely dirty, apply isopropyl alcohol to the cotton swab. (Do not use any other liquid cleaners, because they will damage the lens.) Take care not to use too much of this alcohol on the swab, and do not allow the alcohol to get inside the pick-up.

# NOTES REGARDING COMPACT DISC PLAYER REPAIRS

## 1. Preparations

- 1) Compact disc players incorporate a great many ICs as well as the pick-up (laser diode). These components are sensitive to, and easily affected by, static electricity. If such static electricity is high voltage, components can be damaged, and for that reason components should be handled with care.
- 2) The pick-up is composed of many optical components and other high-precision components. Care must be taken, therefore, to avoid repair or storage where the temperature of humidity is high, where strong magnetism is present, or where there is excessive dust.

## 2. Notes for repair

- 1) Before replacing a component part, first disconnect the power supply lead wire from the unit
- 2) All equipment, measuring instruments and tools must be grounded.
- 3) The workbench should be covered with a conductive sheet and grounded.  
When removing the laser pick-up from its conductive bag, do not place the pick-up on the bag. (This is because there is the possibility of damage by static electricity.)
- 4) To prevent AC leakage, the metal part of the soldering iron should be grounded.
- 5) Workers should be grounded by an armband (1M $\Omega$ )
- 6) Care should be taken not to permit the laser pick-up to come in contact with clothing, in order to prevent static electricity changes in the clothing to escape from the armband.
- 7) The laser beam from the pick-up should NEVER be directly facing the eyes or bare skin.

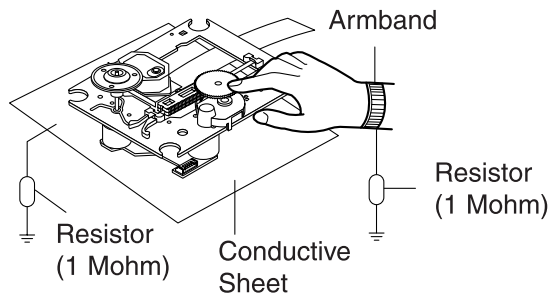

## CLEARING MALFUNCTION

You can reset your unit to initial status if malfunction occur(button malfunction, display, etc.).

Using a pointed good conductor(such as driver), simply short the RESET jump wire on the inside of the volume knob for more than 3 seconds.

If you reset your unit, you must reenter all its settings(stations, clock, timer)

**NOTE:** 1. To operate the RESET jump wire, pull the volume rotary knob and release it.

2. If you wish to operate the RESET jump wire, it is necessary to unplug the power cord.

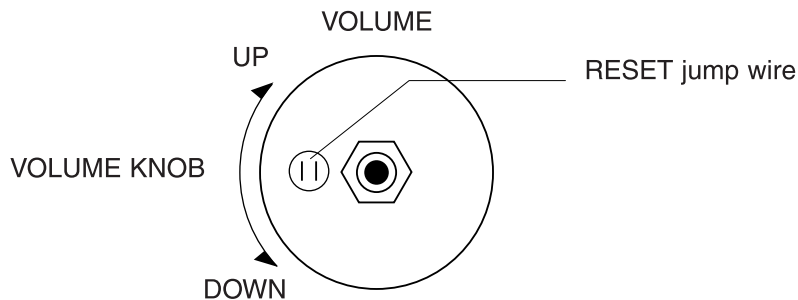

# □ ESD PRECAUTIONS

## Electrostatically Sensitive Devices (ESD)

Some semiconductor (solid state) devices can be damaged easily by static electricity. Such components commonly are called Electrostatically Sensitive Devices (ESD). Examples of typical ESD devices are integrated circuits and some field-effect transistors and semiconductor chip components. The following techniques should be used to help reduce the incidence of component damage caused by static electricity.

1. Immediately before handling any semiconductor component or semiconductor-equipped assembly, drain off any electrostatic charge on your body by touching a known earth ground. Alternatively, obtain and wear a commercially available discharging wrist strap device, which should be removed for potential shock reasons prior to applying power to the unit under test.
2. After removing an electrical assembly equipped with ESD devices, place the assembly on a conductive surface such as aluminum foil, to prevent electrostatic charge buildup or exposure of the assembly.
3. Use only a grounded-tip soldering iron to solder or unsolder ESD devices.
4. Use only an anti-static solder removal device. Some solder removal devices not classified as "anti-static" can generate electrical charges sufficient to damage ESD devices.
5. Do not use freon-propelled chemicals. These can generate electrical charges sufficient to damage ESD devices.
6. Do not remove a replacement ESD device from its protective package until immediately before you are ready to install it. (Most replacement ESD devices are packaged with leads electrically shorted together by conductive foam, aluminum foil or comparable conductive materials).
7. Immediately before removing the protective material from the leads of a replacement ESD device, touch the protective material to the chassis or circuit assembly into which the device will be installed.

**CAUTION : BE SURE NO POWER IS APPLIED TO THE CHASSIS OR CIRCUIT, AND OBSERVE ALL OTHER SAFETY PRECAUTIONS.**

8. Minimize bodily motions when handling unpackaged replacement ESD devices. (Otherwise harmless motion such as the brushing together of your clothes fabric or the lifting of your foot from a carpeted floor can generate static electricity sufficient to damage an ESD device).

## CAUTION. GRAPHIC SYMBOLS



THE LIGHTNING FLASH WITH APOWHEAD SYMBOL. WITHIN AN EQUILATERAL TRIANGLE, IS INTENDED TO ALERT THE SERVICE PERSONNEL TO THE PRESENCE OF UNINSULATED "DANGEROUS VOLTAGE" THAT MAY BE OF SUFFICIENT MAGNITUDE TO CONSTITUTE A RISK OF ELECTRIC SHOCK.



THE EXCLAMATION POINT WITHIN AN EQUILATERAL TRIANGLE IS INTENDED TO ALERT THE SERVICE PERSONNEL TO THE PRESENCE OF IMPORTANT SAFETY INFORMATION IN SERVICE LITERATURE.

## □ SPECIFICATIONS

SECTION	MODEL	LX-U150A/D/X	
<b>General</b>	Power supply	Refer to the back panel of the unit	
	Power consumption	20W	
	Mass	3kg	
	External dimensions(WxHxD)	146x238x251mm	
<b>CD</b>	Frequency Response	40 ~ 18000Hz	
	Signal-to-noise ratio	60dB	
	Dynamic Range	60dB	
<b>TUNER</b>	<b>FM</b>	Tuning Range	87.5 ~ 108.0MHz or 65 ~74MHz, 87.5 ~ 108.0MHz
		Intermediate Frequency	10.7MHz
		Signal-to-noise ratio	55/50dB(Mono/Stereo)
		Frequency Response	60 ~ 1000Hz
	<b>AM</b>	Tuning Range	522 ~ 1620kHz or 520 ~ 1720kHz
		Intermediate Frequency	450kHz
		Signal-to-noise ratio	35dB
		Frequency Response	100 ~ 1800Hz
<b>AMP</b>	Output Power	5W + 5W	
	T.H.D	0.5%	
	Frequency Response	60 ~ 20000Hz	
	Signal-to-noise ratio	60dB	
<b>TAPE</b>	Tape Speed	4.75cm/sec	
	Wow Flutter	0.3%(MTT-111, JIS-WTD)	
	F.F/REW time	120sec(C-60)	
	Frequency Response	250 ~ 8000 Hz	
	Signal-to-noise ratio	40dB(P/B)/38dB(R/P)	
	Channel Separation	32dB(P/B)/30dB(R/P)	
	Erase Ratio	50dB(MTT-5511)	
<b>SPEAKER</b>	<b>MODEL</b>	<b>LXS-U150</b>	
	Type	1Way 1 Speaker	
	Impedance	4Ω	
	Frequency Response	100 ~ 18000Hz	
	Sound Pressure Level	86dB/W(1m)	
	Rated Input Power	5W	
	Max.Input Power	10W	
	Net Dimension(WxHxD)	146x238x185mm	
	Net weight	1.4kg	

**NOTE : Specification are subject to change without notice in the course of product improvement.**

# MEMO

# SECTION 2. ELECTRICAL

## □ ADJUSTMENTS

This set has been aligned at the factory and normally will not require further adjustment. As a result, it is not recommended that any attempt is made to modificate any circuit. If any parts are replaced or if anyone tampers with the adjustment, realignment may be necessary.

### IMPORTANT

1. Check Power-source voltage.
2. Set the function switch to band being aligned.
3. Turn volume control to minimum unless otherwise noted.
4. Connect low side of signal source and output indicator to chassis ground unless otherwise specified.
5. Keep the signal input as low as possible to avoid AGC and AC action.

### TAPE DECK ADJUSTMENT

	Item	Test Tape	Test Point	Adjustment	Adjust for	Remark
1	Azimuth	MTT-114	Speaker out	Azimuth Screw	Maximum	
2	Bias Frequency	Tape Rec	Tape Rec	L201	65V ± 5kHz	

### TUNER ADJUSTMENT

	Item	Test Frequency	Test Point	Adjustment	Adjust for	Remark
1	DC Voltage	FM 98MHz 60dBuV	Oscilloscope	L104	0V ± 50mV	R145
2	AM IF	AM 603kHz 80dBu	Speaker out	L103	Maximum	Maximum Waveform



# □ WAVEFORMS OF MAJOR CHECK POINT

#1. MICOM INTERFACE WAVEFORM

(PN805 PIN 3, 4, 5, 6) during power on

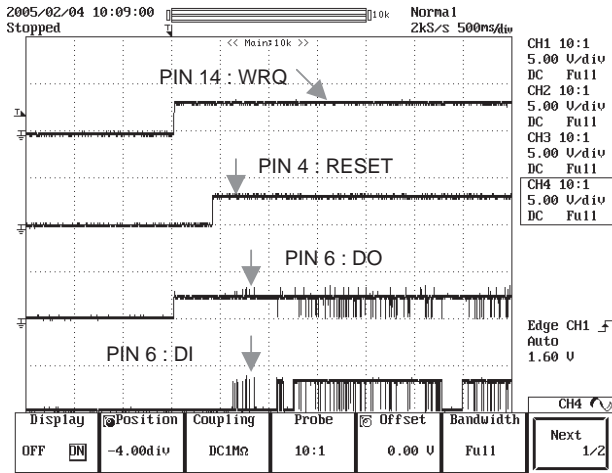

#1. MICOM INTERFACE WAVEFORM

(PN805 PIN 3, 4, 5, 6) during normal play

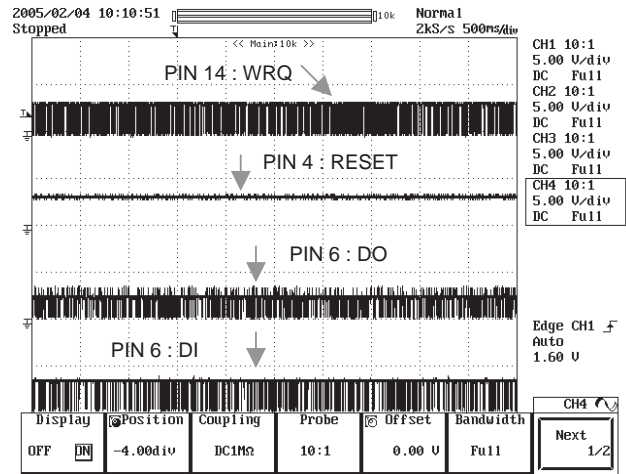

#1. MICOM INTERFACE WAVEFORM

(PN805 PIN 7, 8, 9) during power on

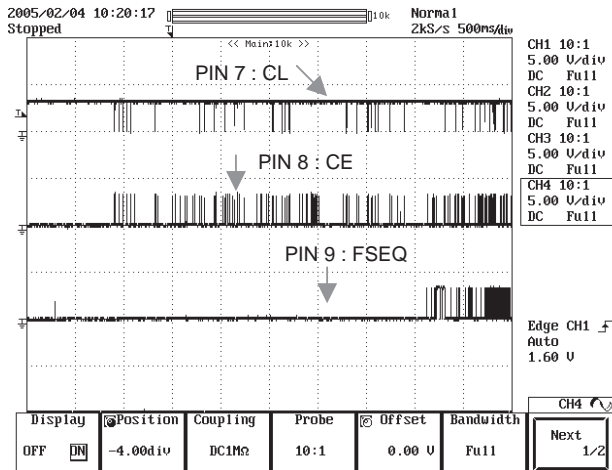

#1. MICOM INTERFACE WAVEFORM

(PN805 PIN 7, 8, 9) during normal play

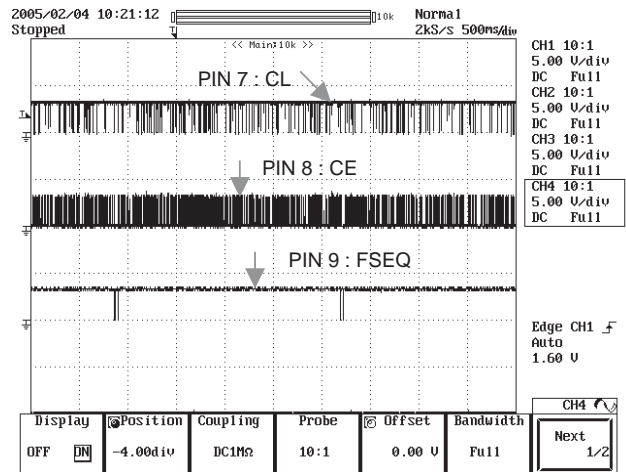

#2. SLED DRIVE AND MOTOR WAVEFORM  
(IC802 PIN 5, 13) when focus search

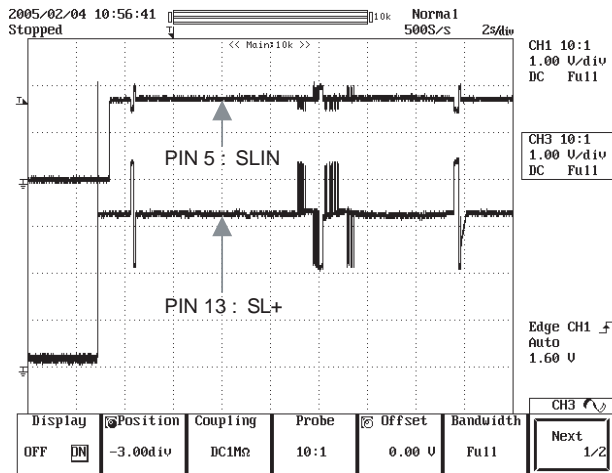

#2. SLED DRIVE AND MOTOR WAVEFORM  
(IC802 PIN 5, 13) during normal play

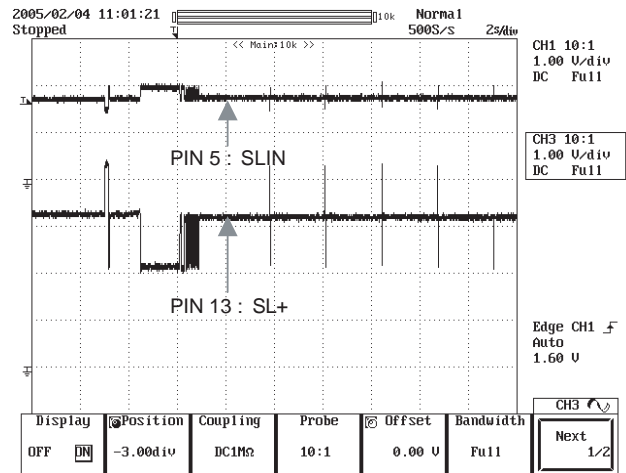

#3. FOCUS DRIVE AND MOTOR WAVEFORM  
(IC802 PIN 25, IC802 PIN 16)

- When focus search failed or there is no disc on tray

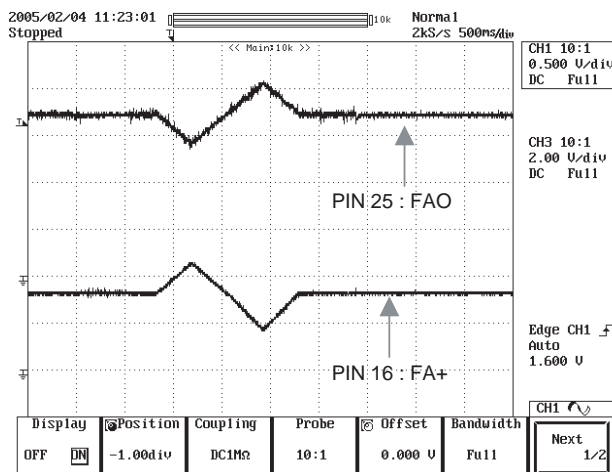

#3. FOCUS DRIVE AND MOTOR WAVEFORM  
(IC802 PIN 25, IC802 PIN 16)

- There is disc on tray and focus search success

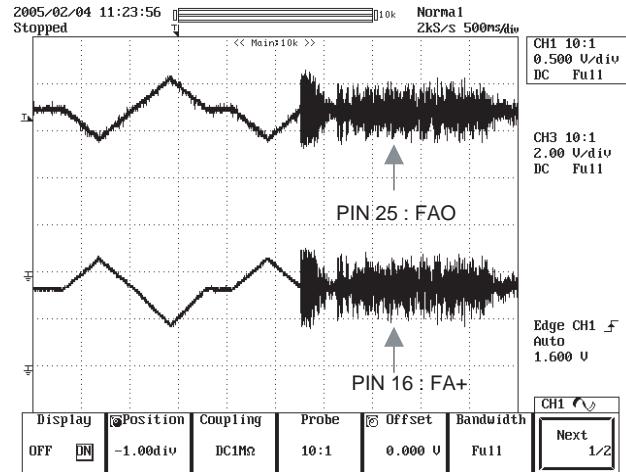

#4. SPINDLE DRIVE AND MOTOR WAVEFORM

(IC802 PIN 6, 11) when TOC reading

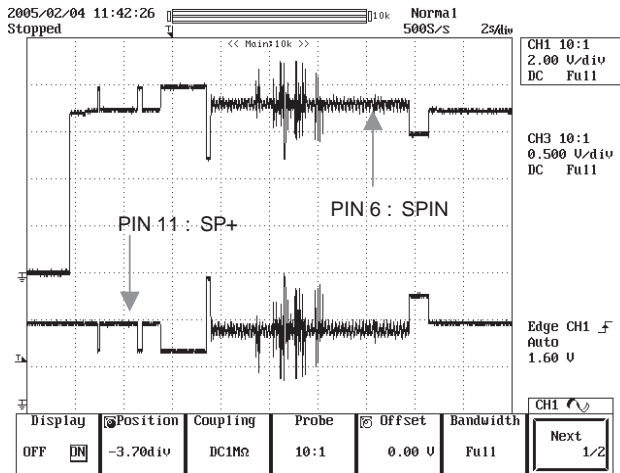

#5. TRACK DRIVE AND MOTOR WAVEFORM

(IC802 PIN 22, IC802 PIN 17) during normal play

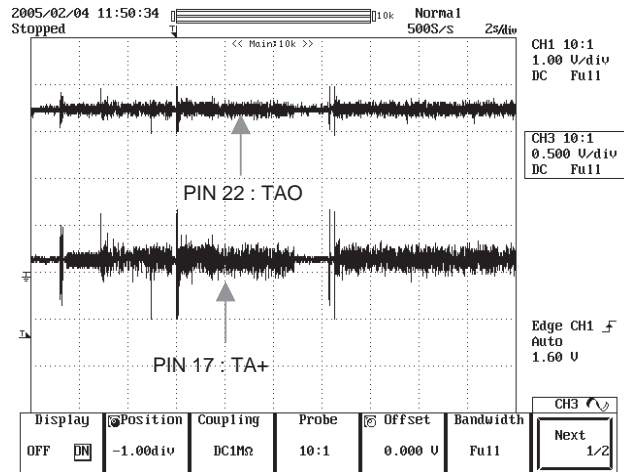

#6. RF, FOCUS AND TRACKING ERROR WAVEFORM

(IC801 PIN 2, 10, 16) during normal play

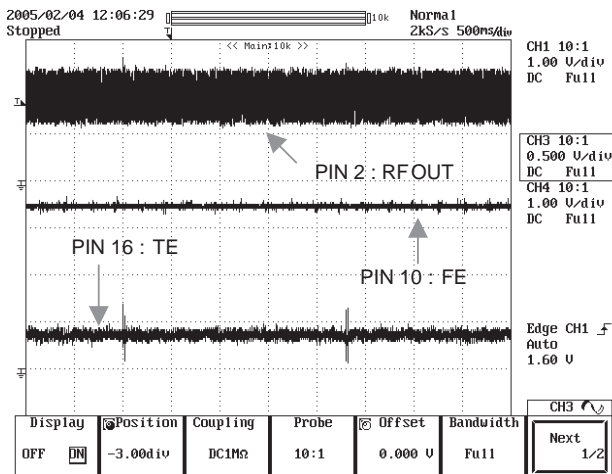

# ❑ TROUBLESHOOTING

## • AUDIO PART

### P-SENS PART

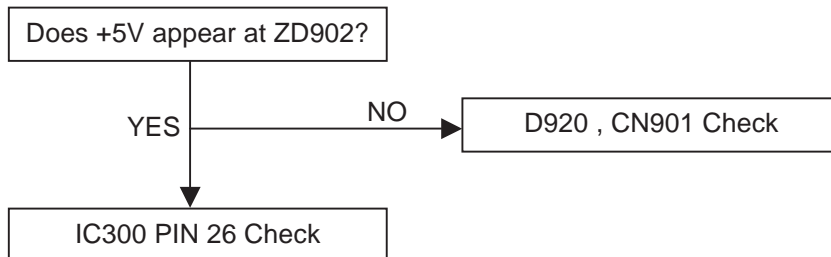

### POWER CIRCUIT

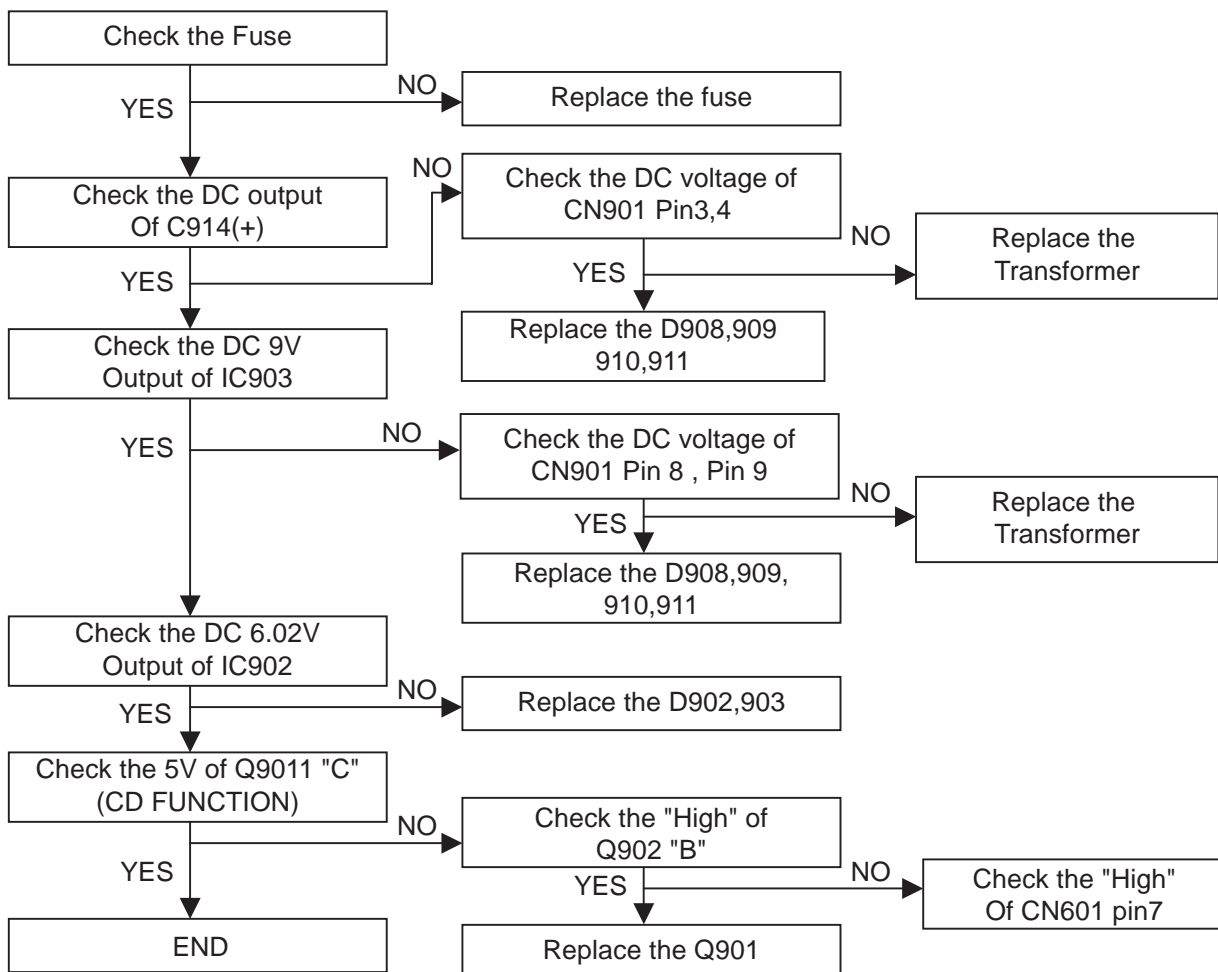

## MUTING CIRCUIT(MUTE)

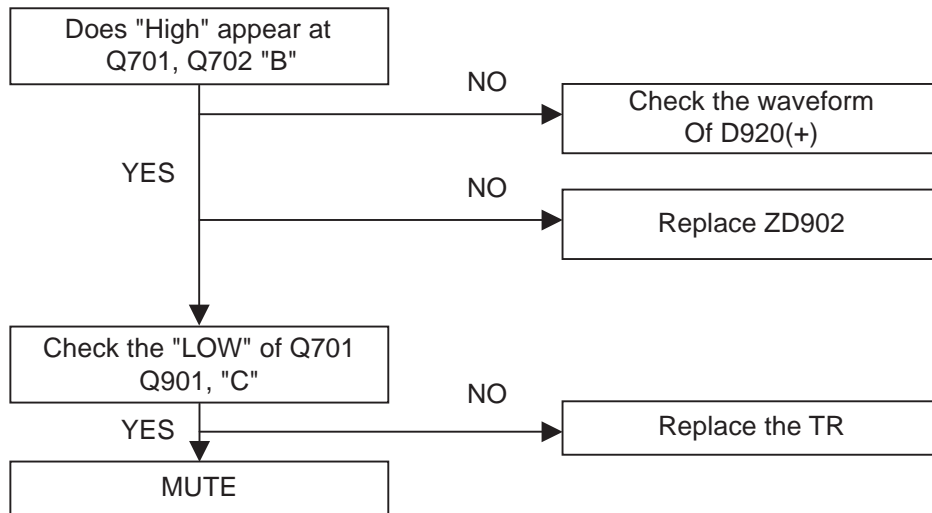

## AUDIO ABNORMAL

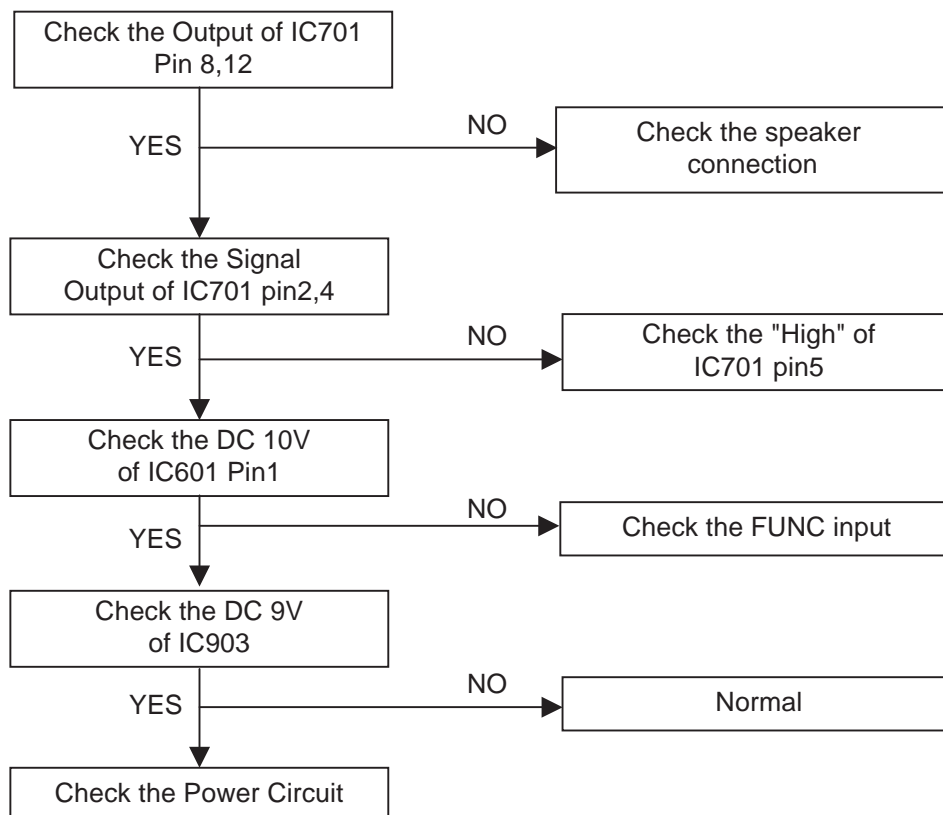

# FUNCTION MODE AUDIO ABNORMAL

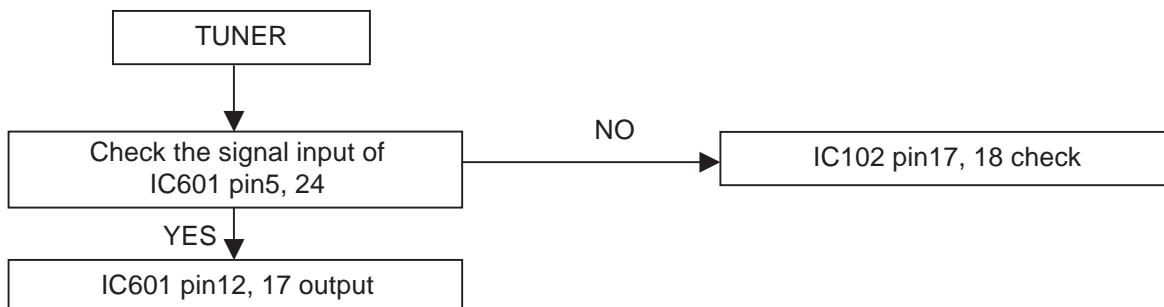
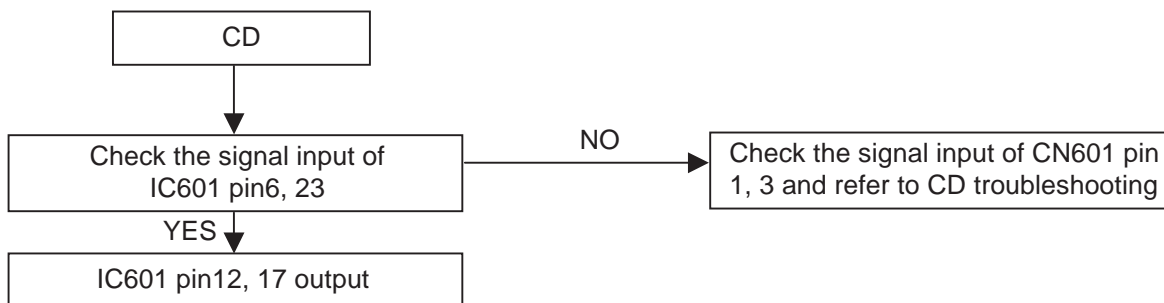
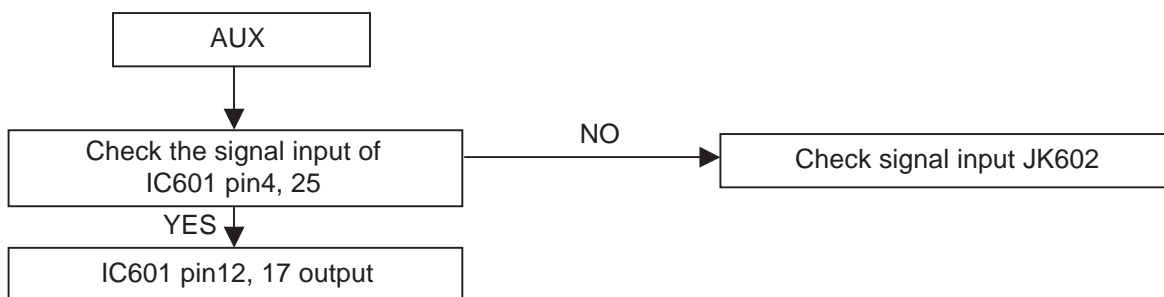
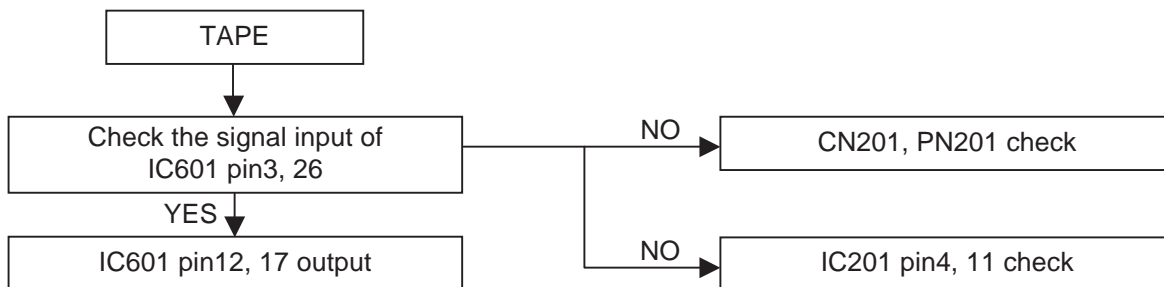

## IC301 TROUBLESHOOTING

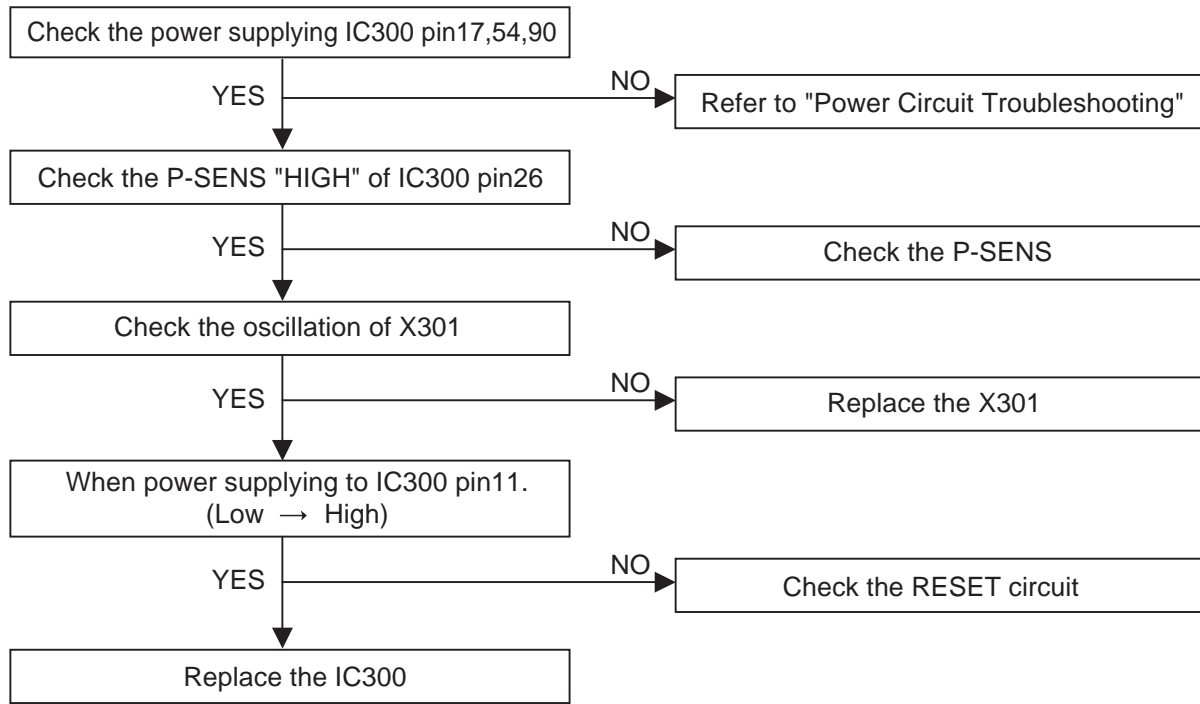

## IC601 TROUBLESHOOTING

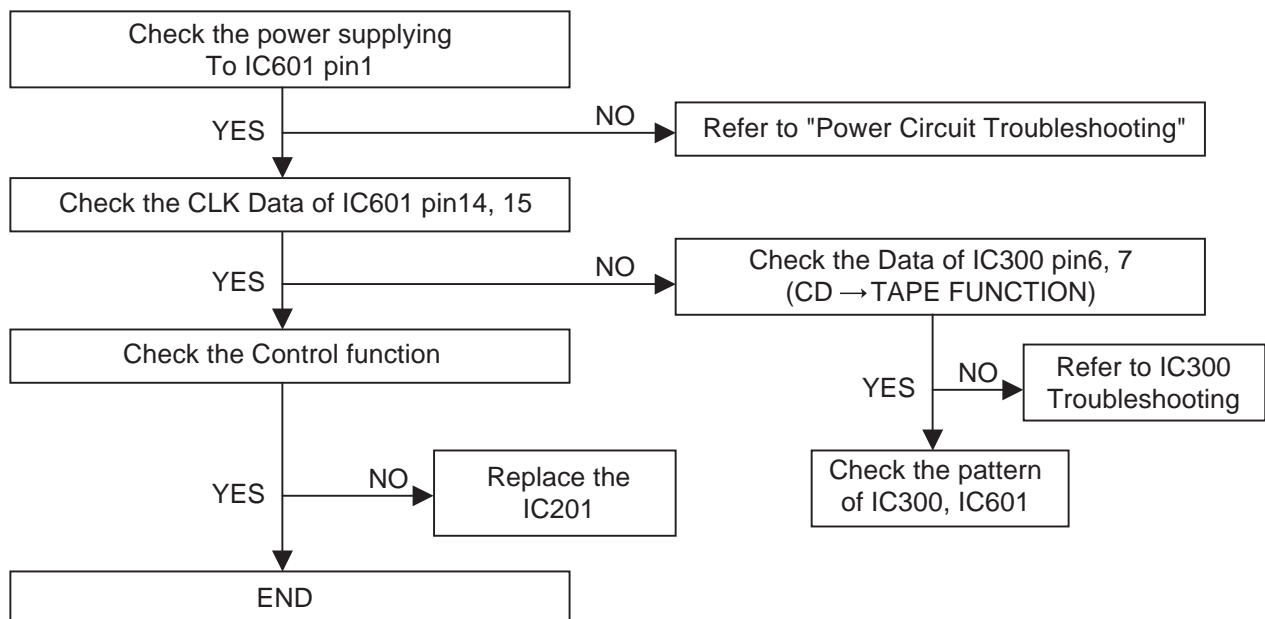

## IC103 TROUBLESHOOTING

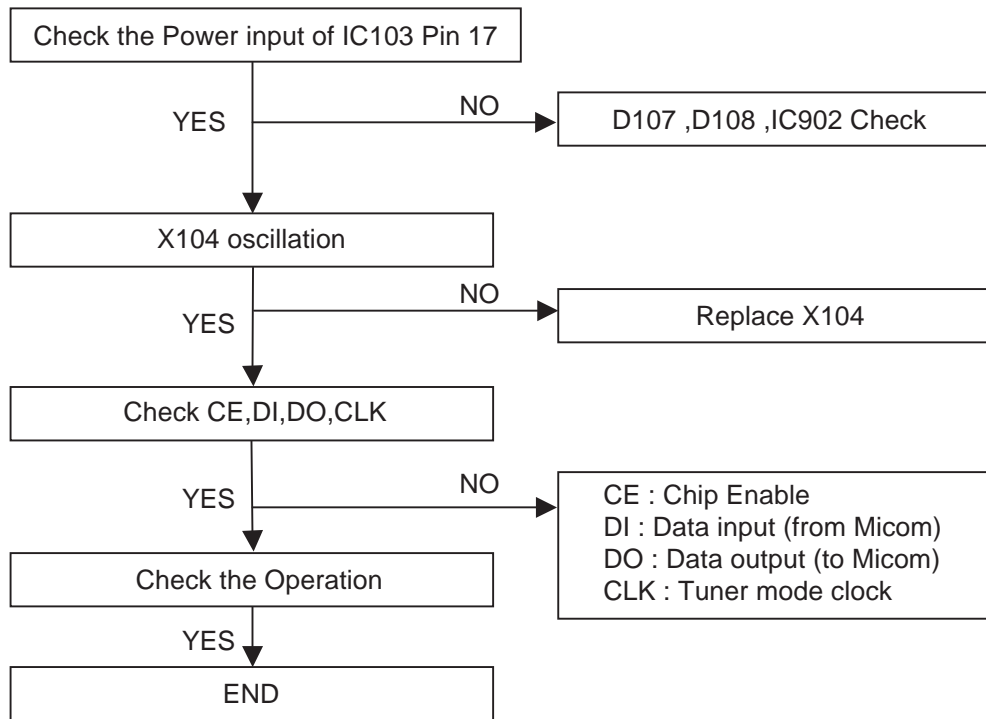

## AM COIL TROUBLESHOOTING

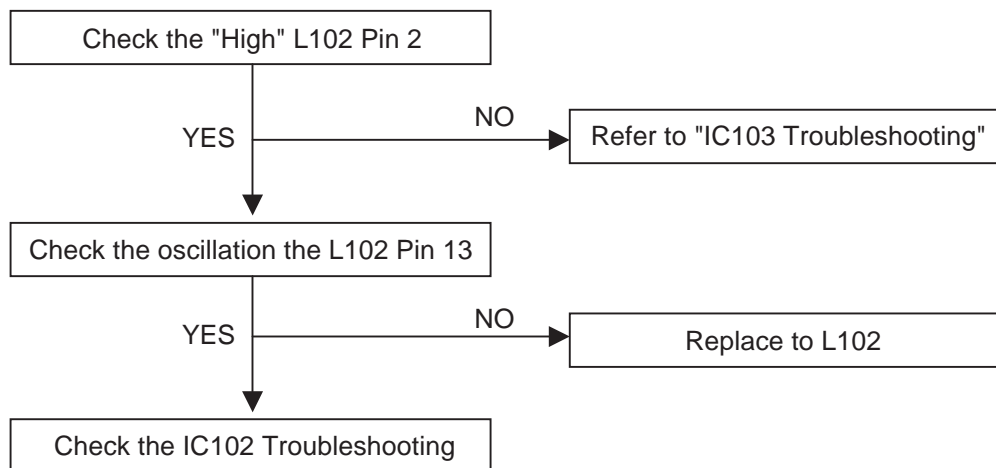



## FM(TU101) TROUBLESHOOTING

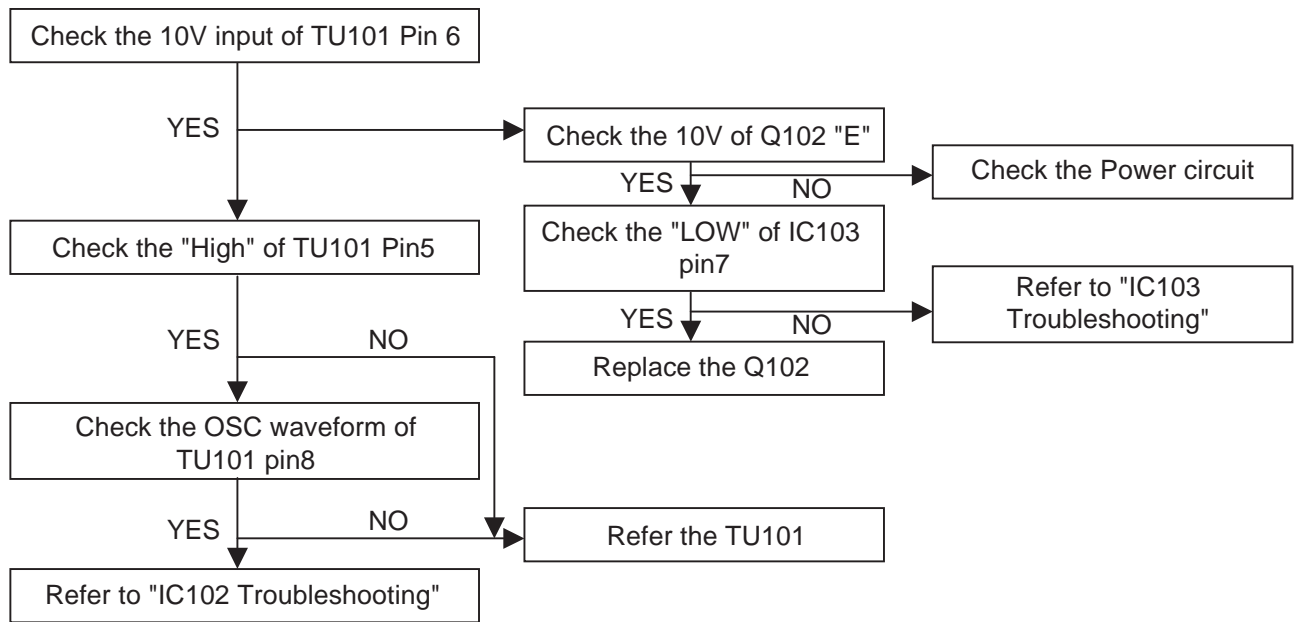

## IC 102 TROUBLESHOOTING

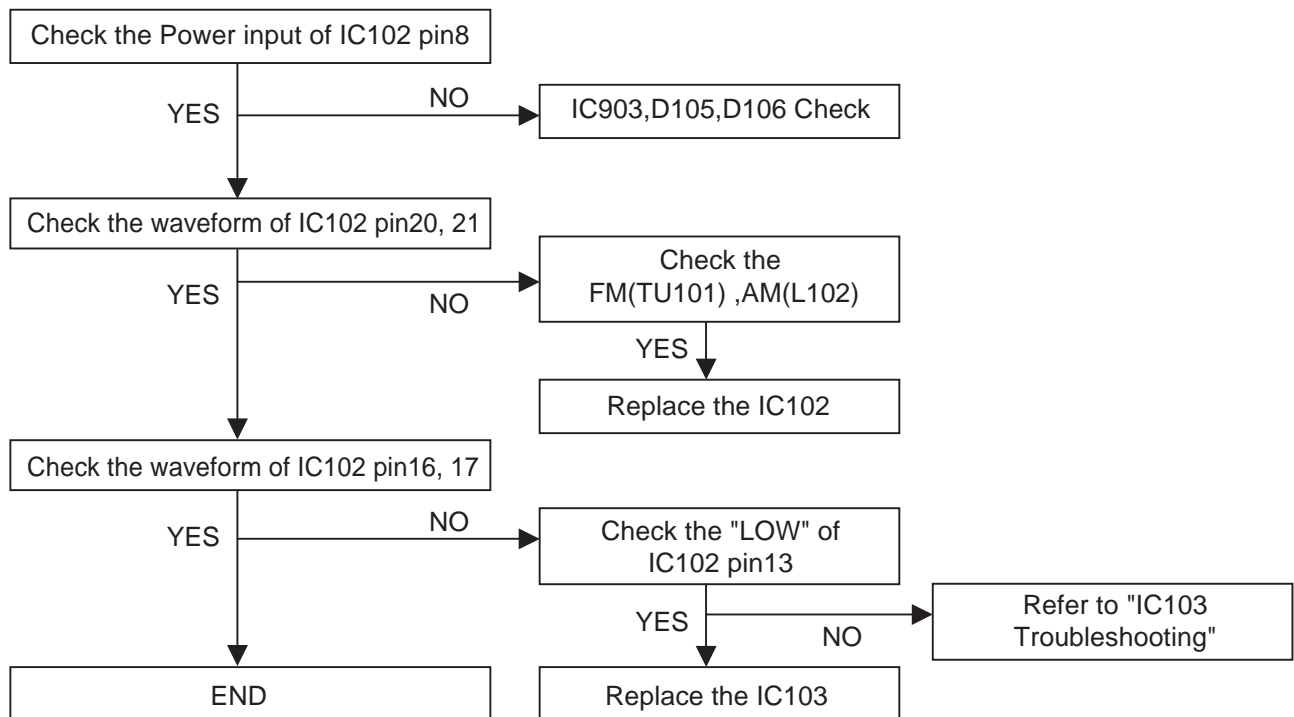

## DECK PLAY

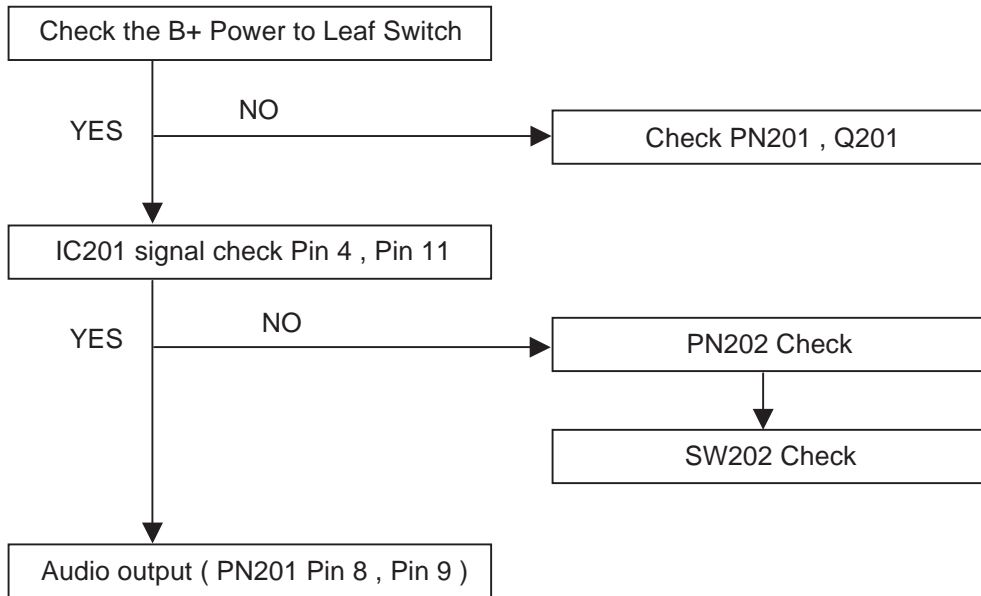

## RECORDING

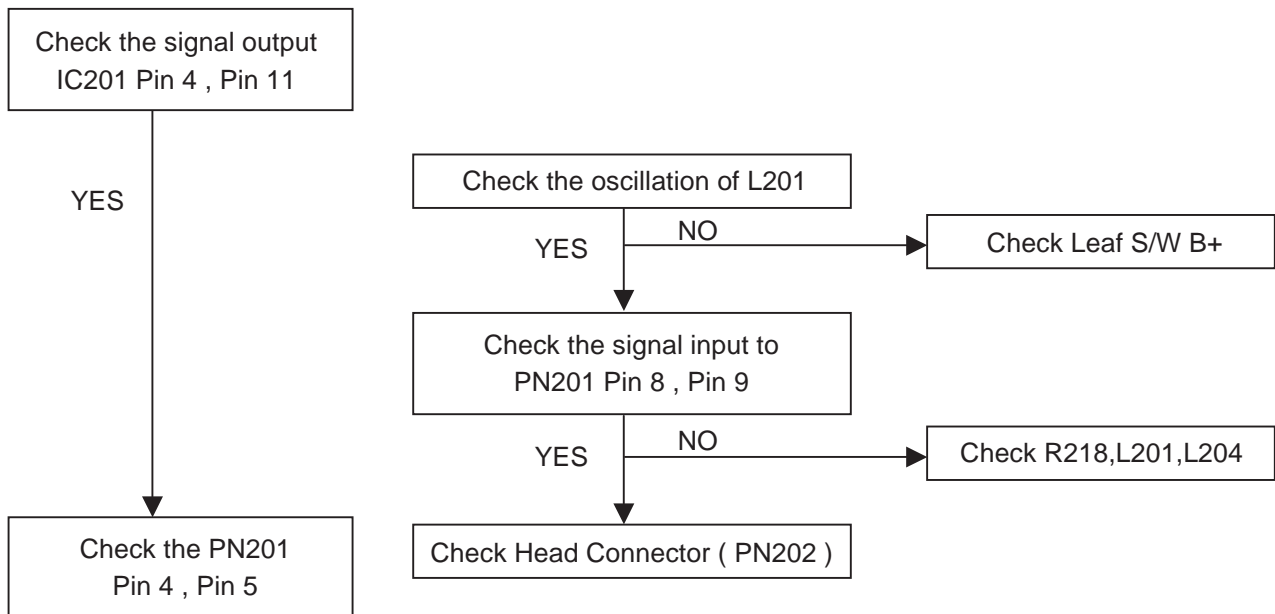

# • CD PART

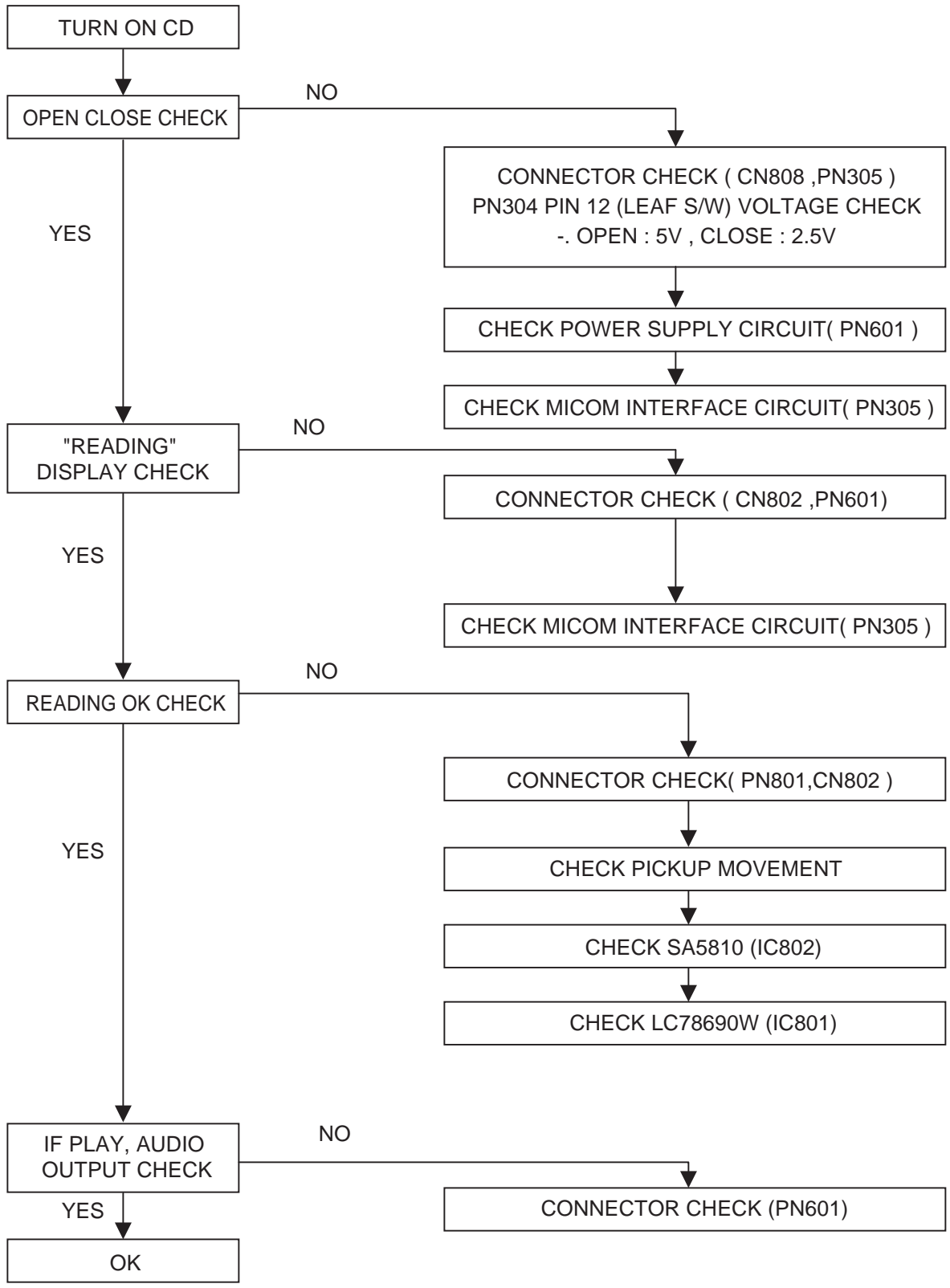

## OPEN CLOSE NG

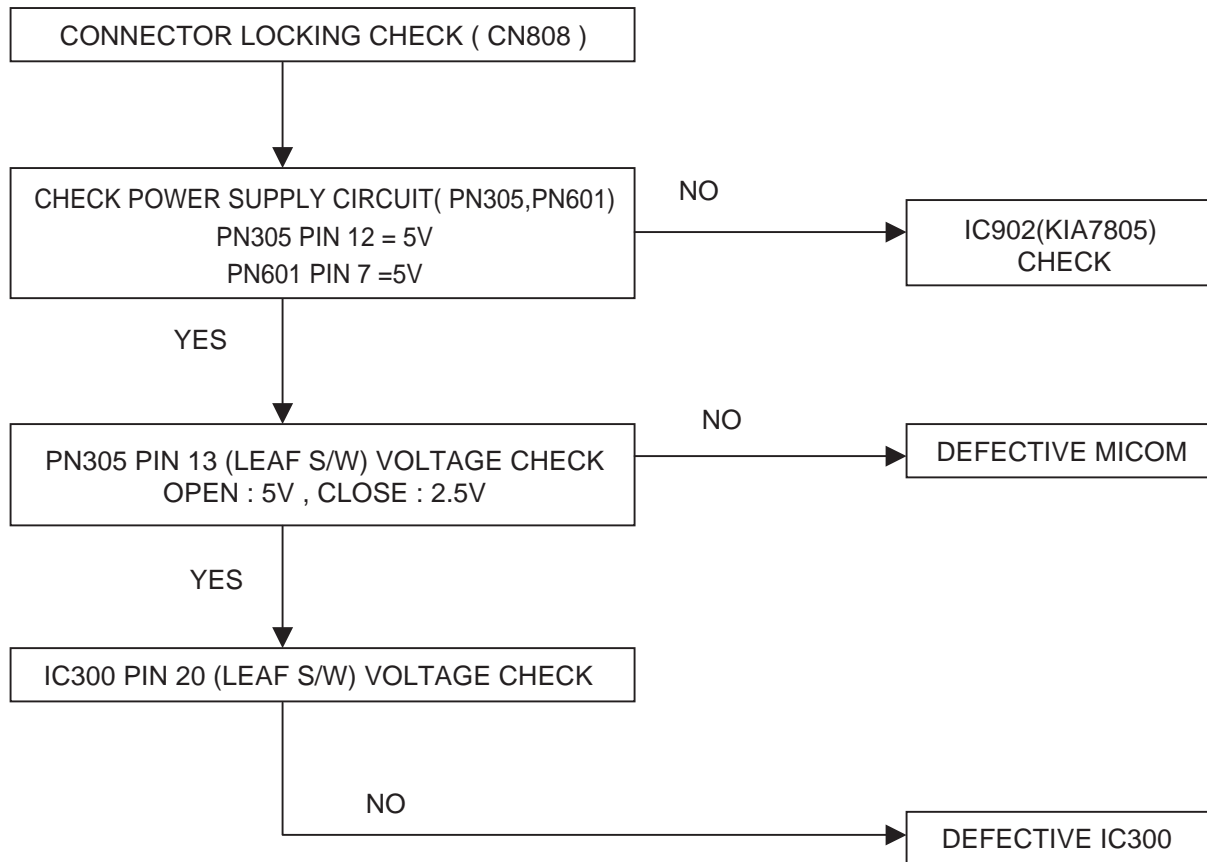

# "READING" DISPLAY CHECK (= ONLY "CD" DISPLAY)

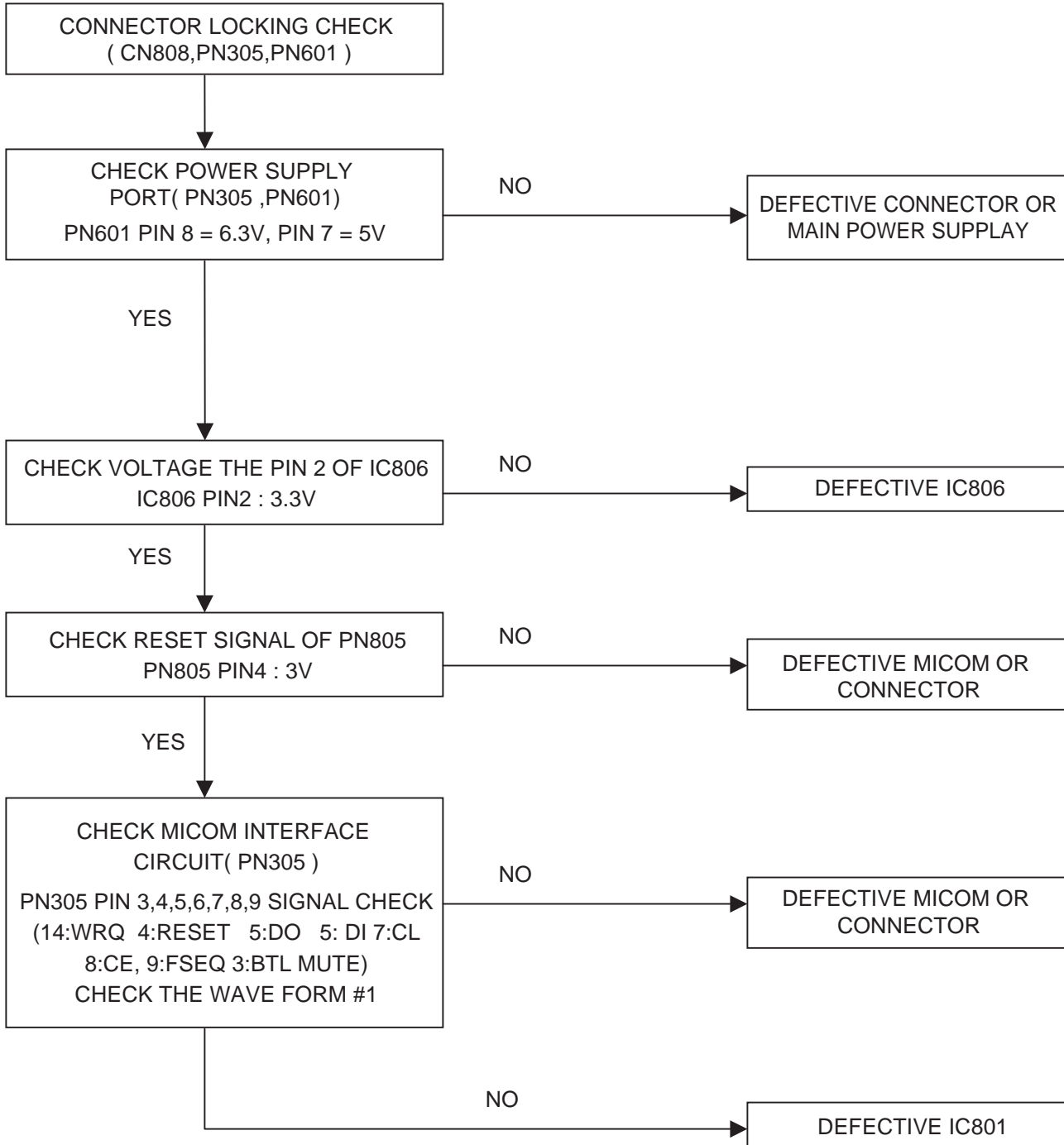

# READING OK CHECK (= "NO DISC" DISPLAY)

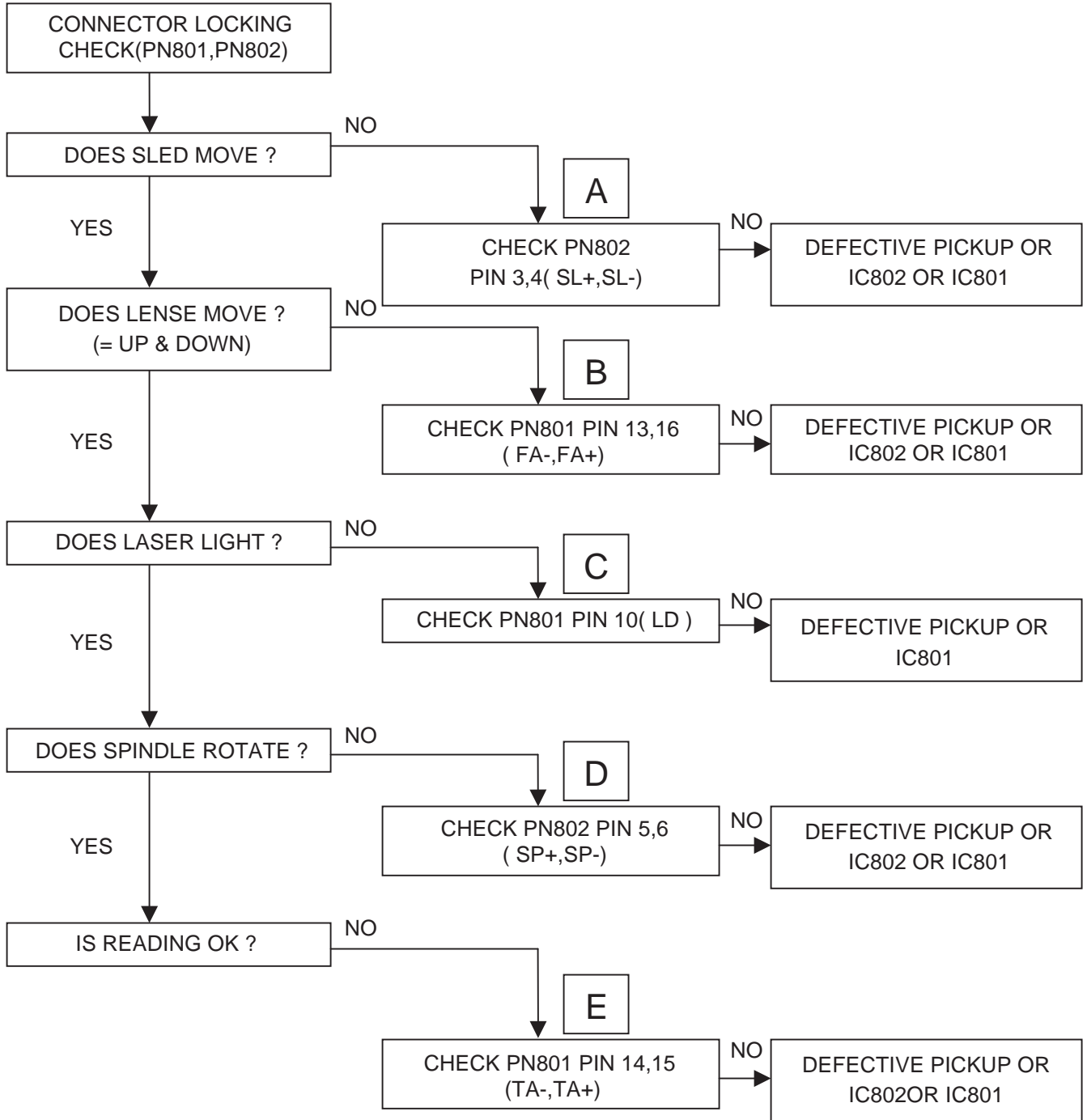

**READING OK CHECK #A  
(= "NO DISC" DISPLAY)**

A

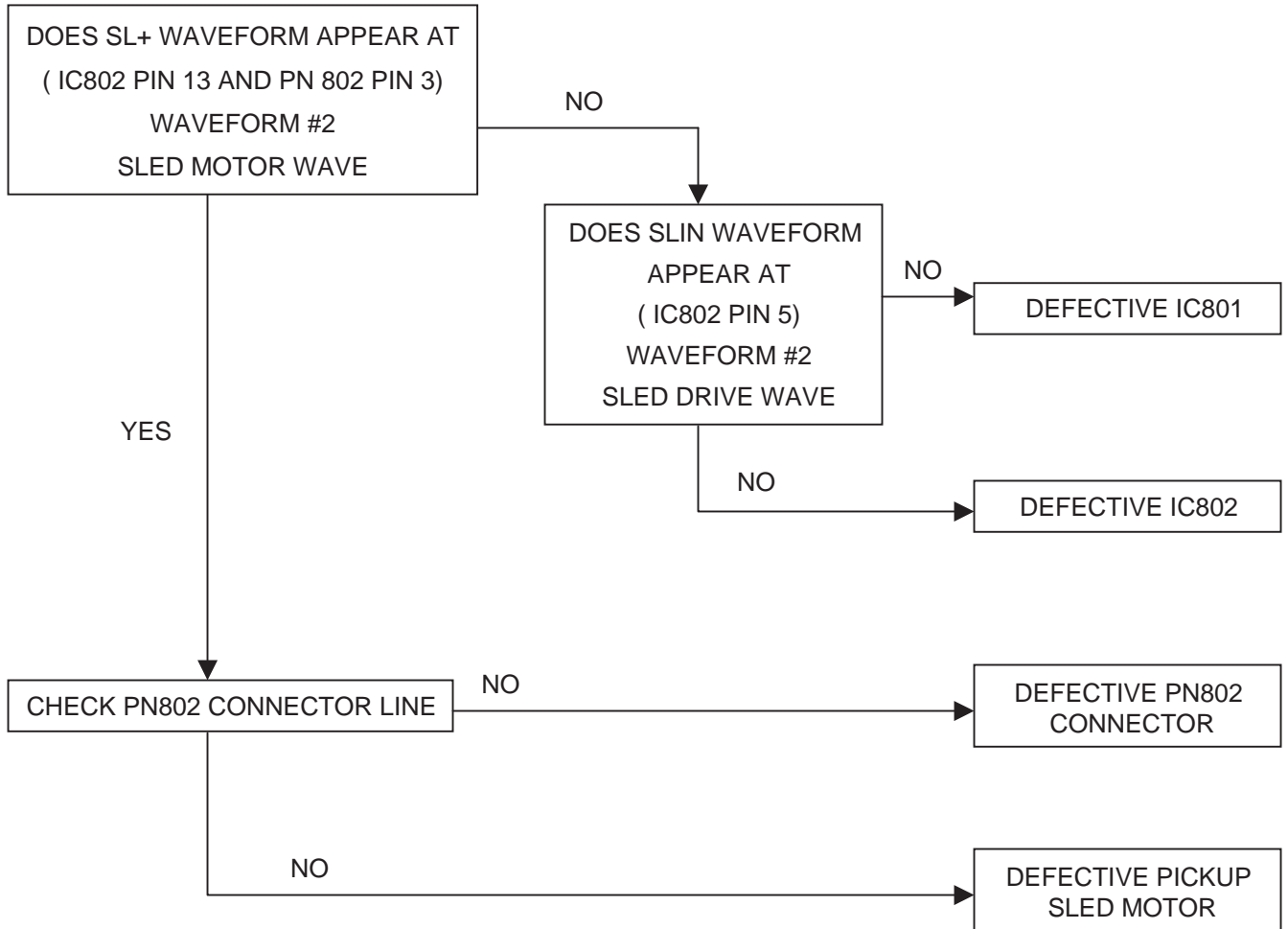

**READING OK CHECK #B  
(= "NO DISC" DISPLAY)**

**B**

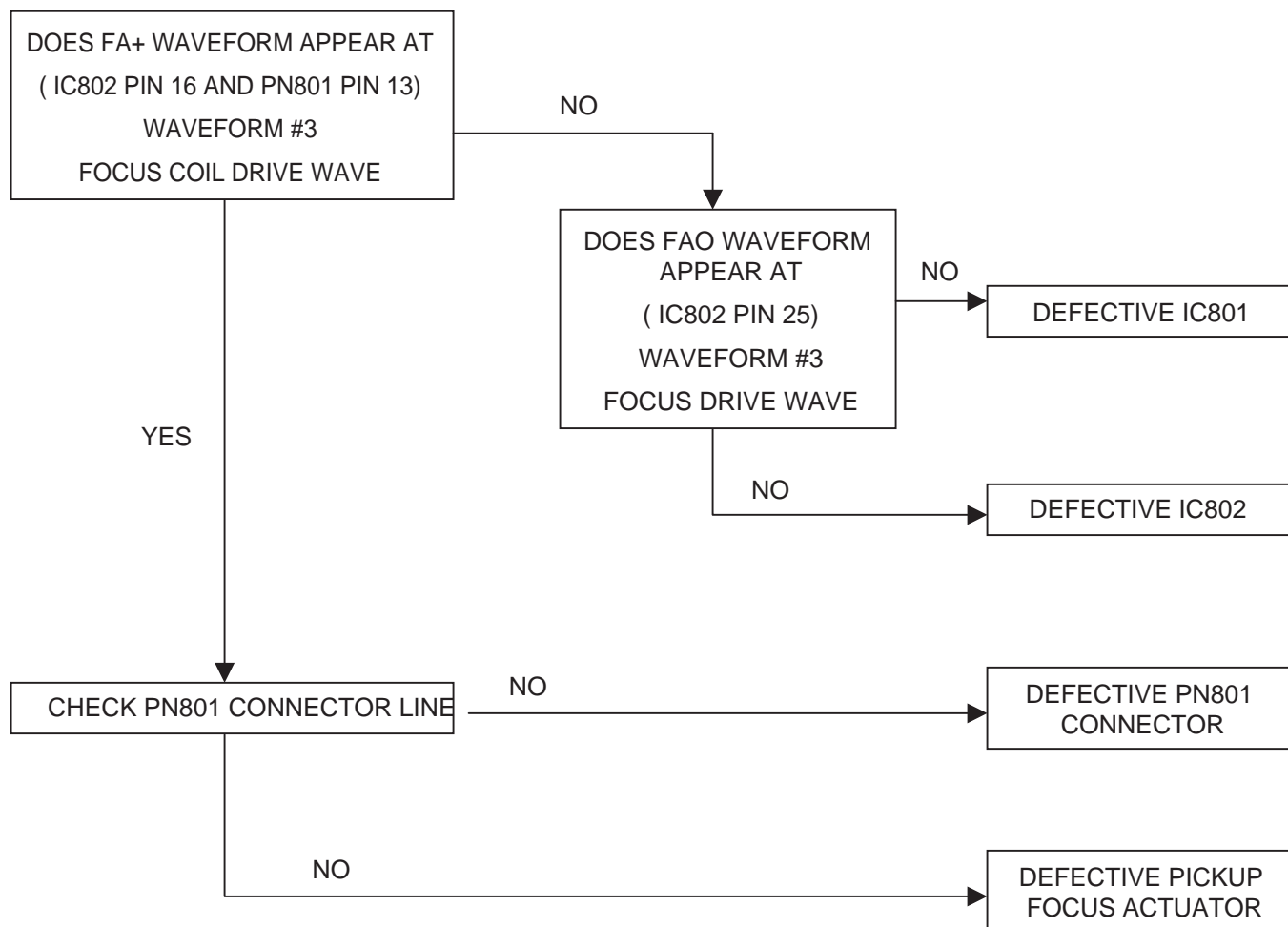



# READING OK CHECK #C (= "NO DISC" DISPLAY)

C

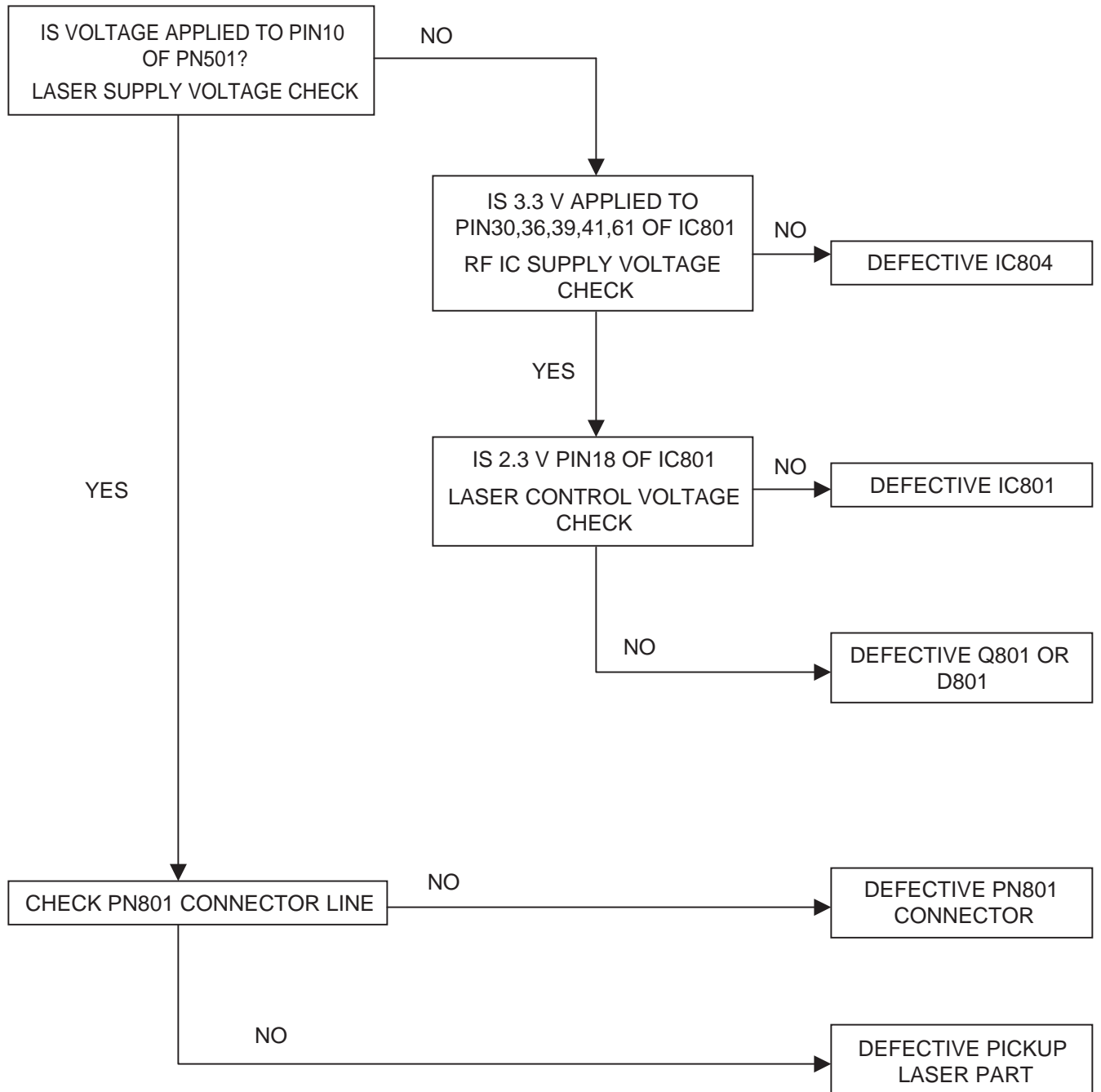

# READING OK CHECK #D (= "NO DISC" DISPLAY)

D

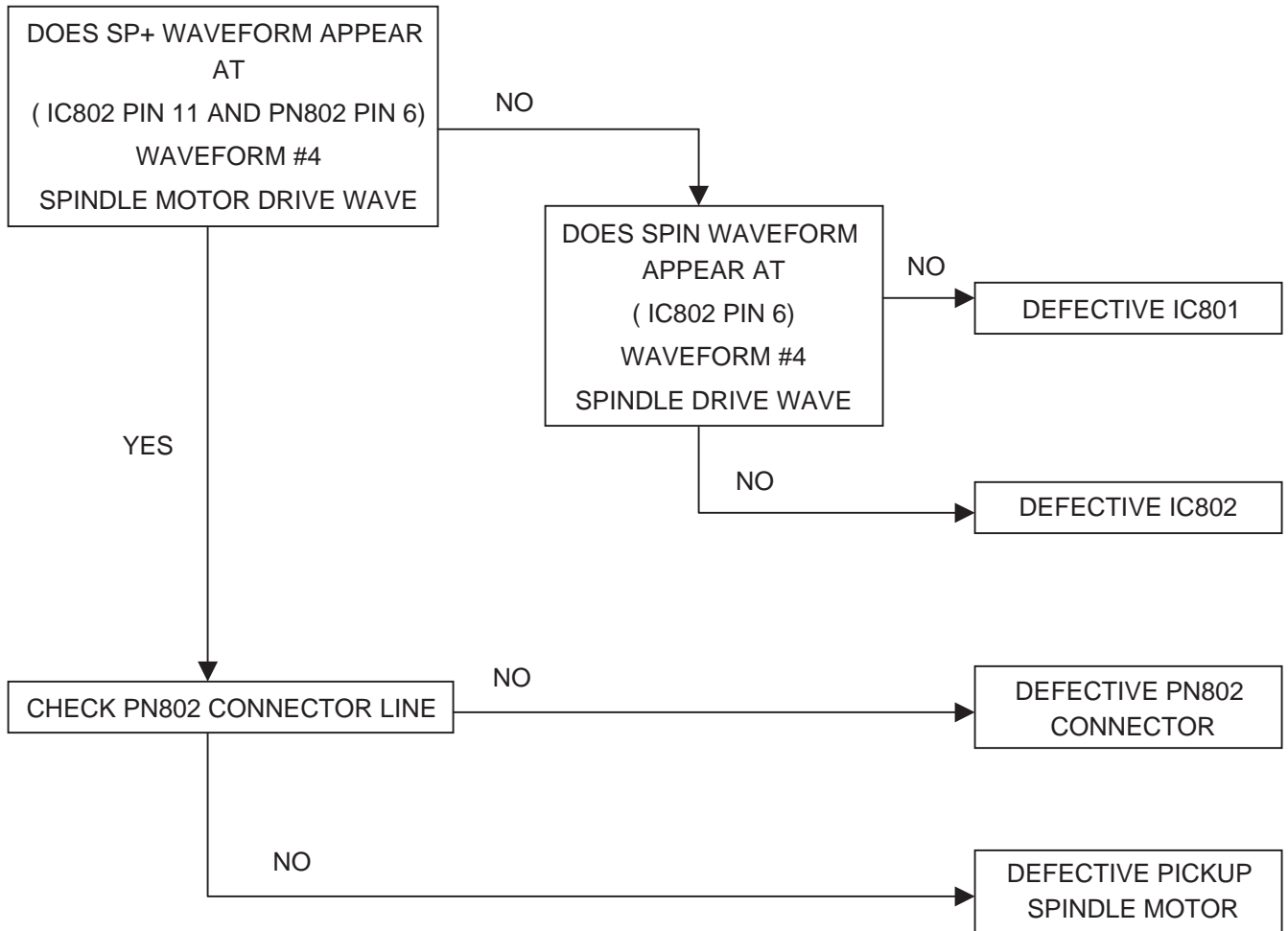

# READING OK CHECK #E (= "NO DISC" DISPLAY)

E

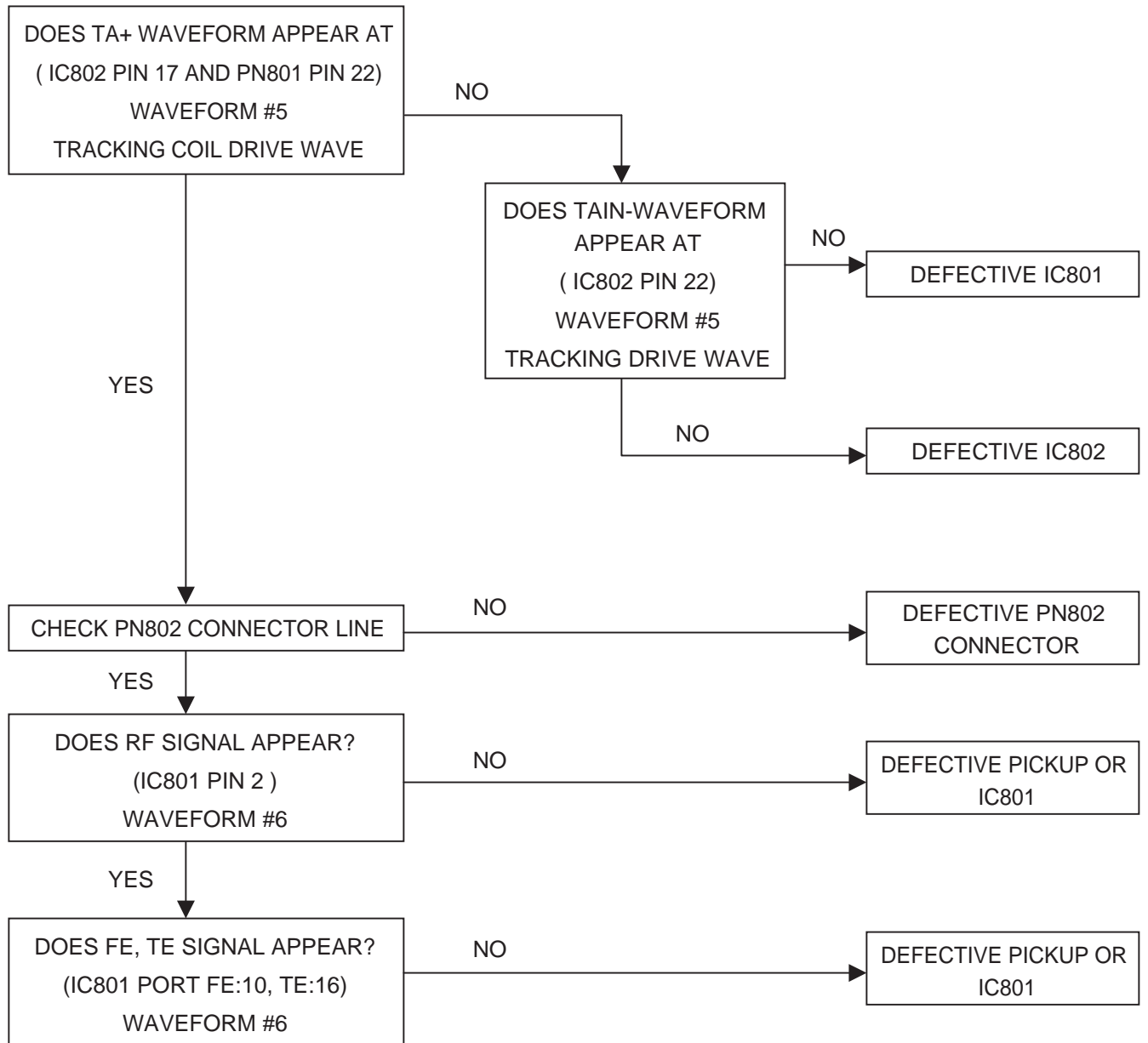

# • USB PART

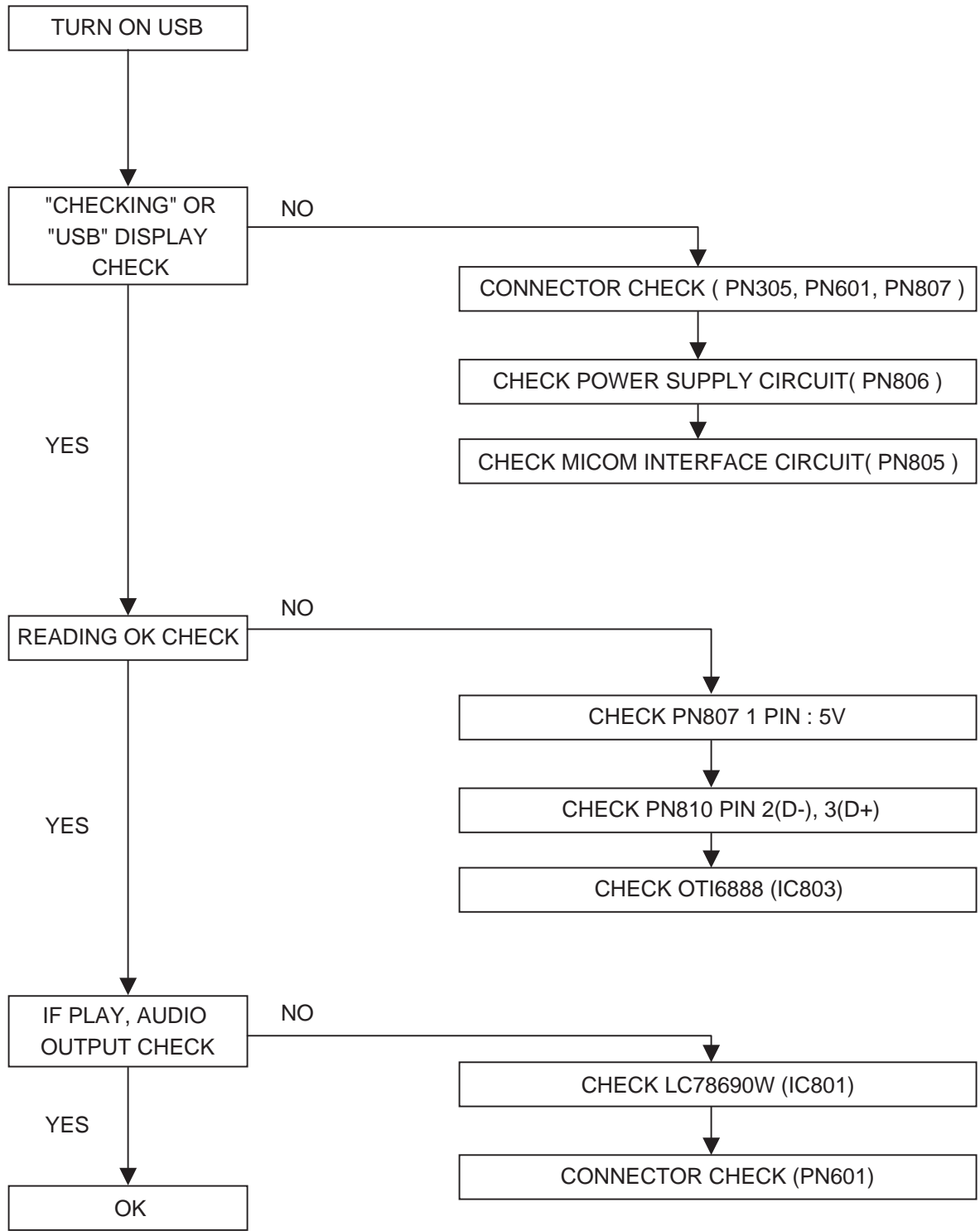

# MEMO

# □ BLOCK DIAGRAM

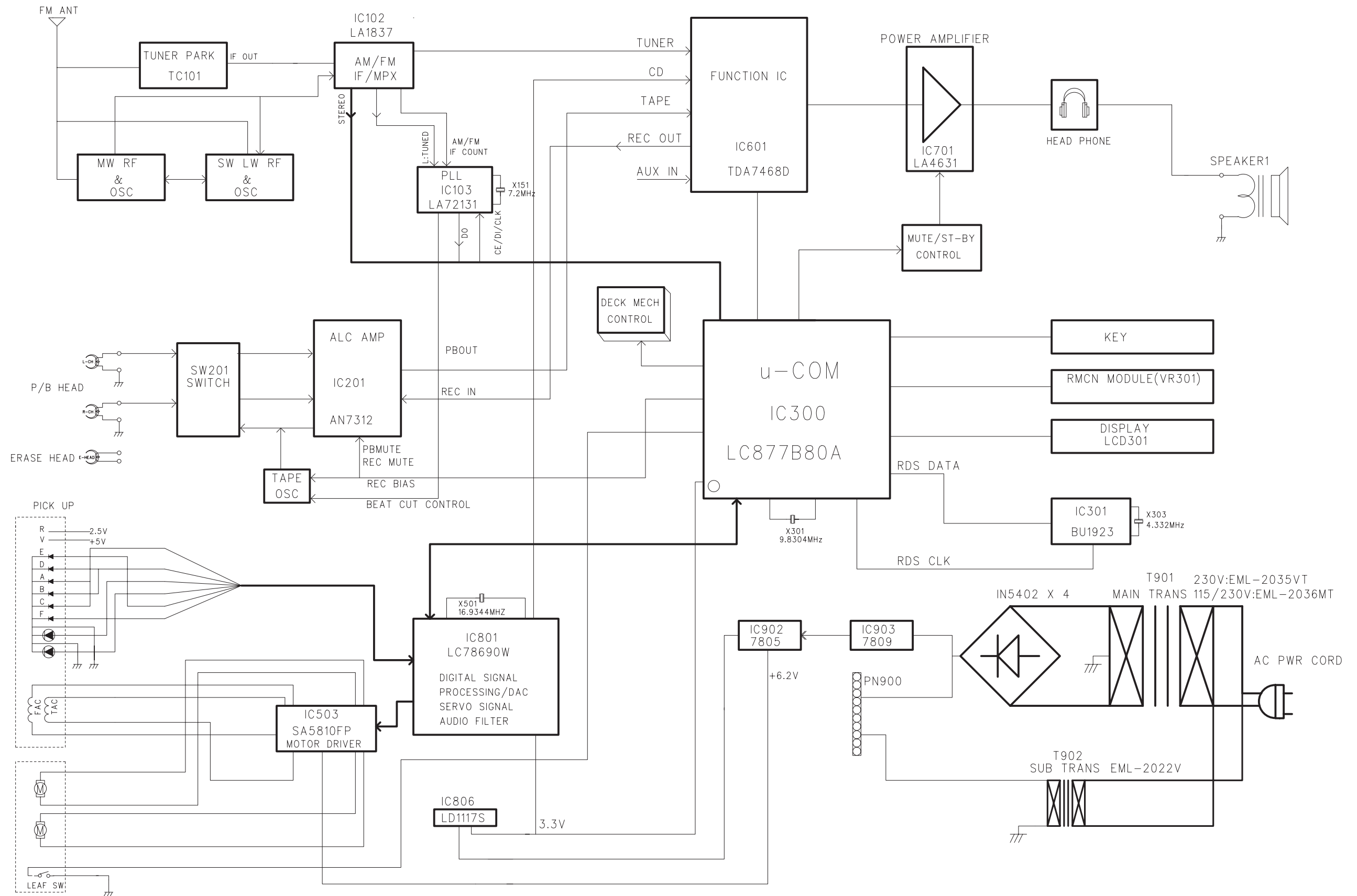

# SCHEMATIC DIAGRAMS

## MAIN & DECK SCHEMATIC DIAGRAM

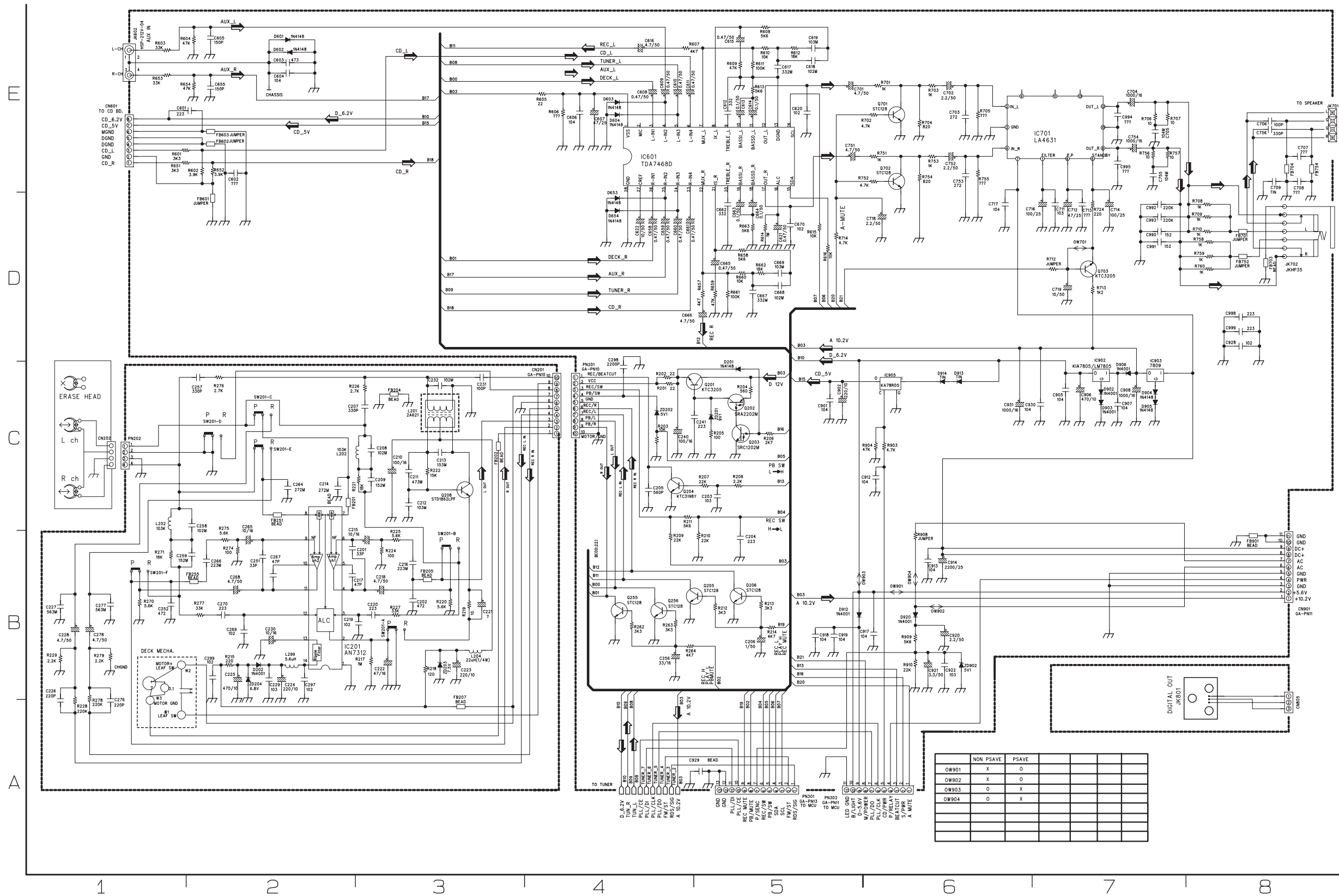

# • CD & USB SCHEMATIC DIAGRAM

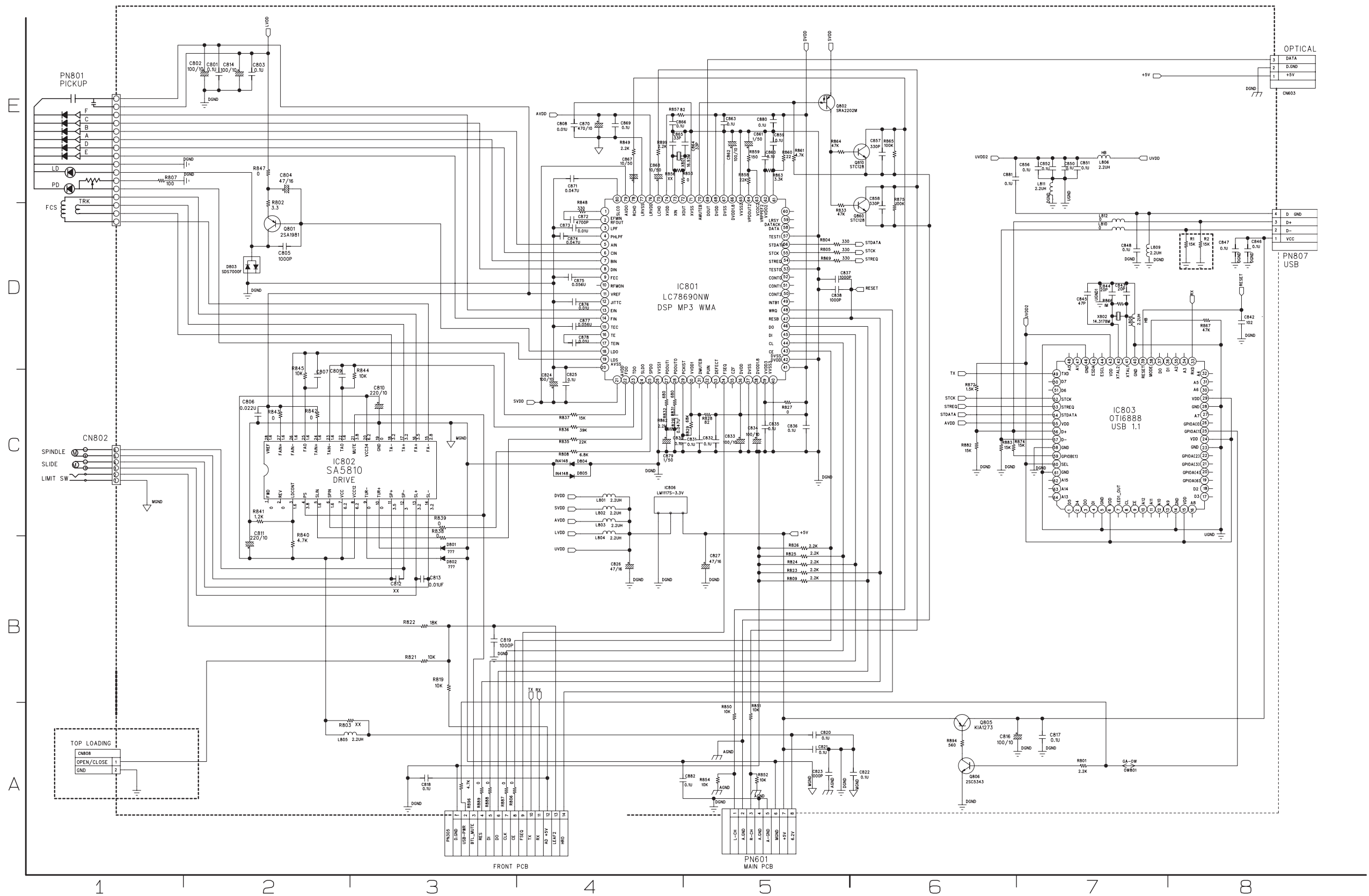



• FRONT, POWER & USB SCHEMATIC DIAGRAM

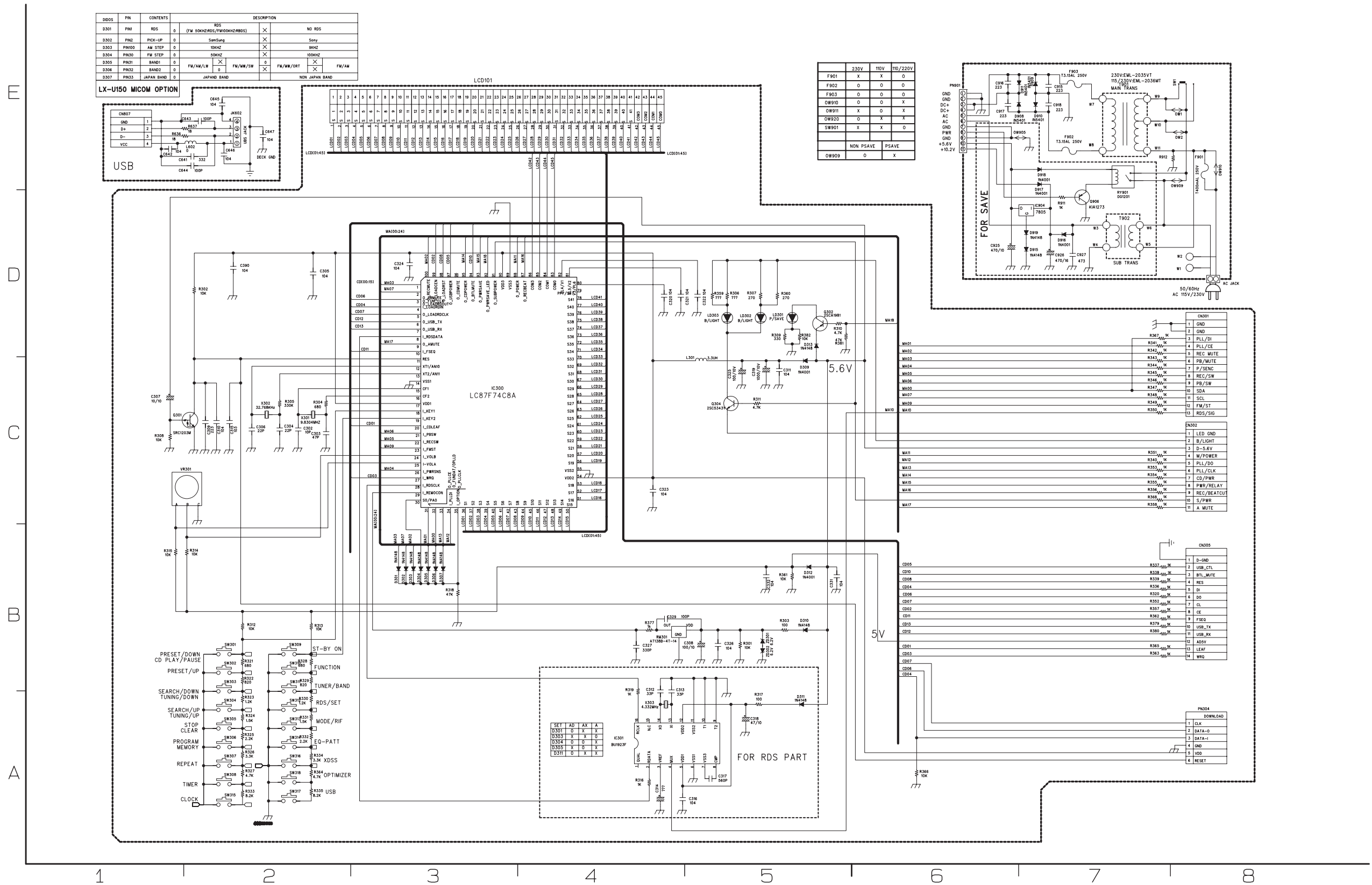

DD05	FN	CONTENTS	DESCRIPTION
D301	FN1	RDS	RDS NO RDS
D302	FN2	PICK-UP	Sony
D303	FN100	AM STEP	50KHZ
D304	FN30	FM STEP	50KHZ
D305	FN31	BAND1	FM/AM/LW
D306	FN32	BAND2	FM/AM/SH
D307	FN33	JAPAN BAND	JAPAN BAND NON JAPAN BAND

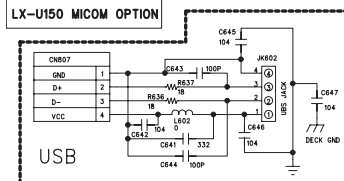

	230V	110V	110/220V
F901	X	X	0
F902	0	0	0
OW910	0	0	X
OW911	X	0	X
OW920	0	X	X
SW901	X	X	0
OW909	0	X	X

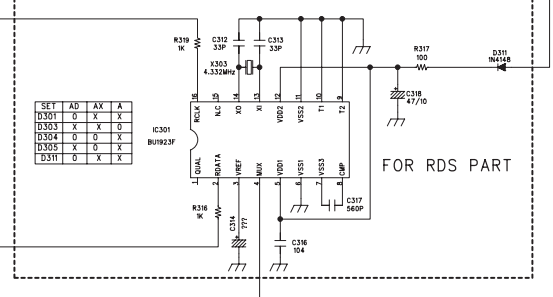
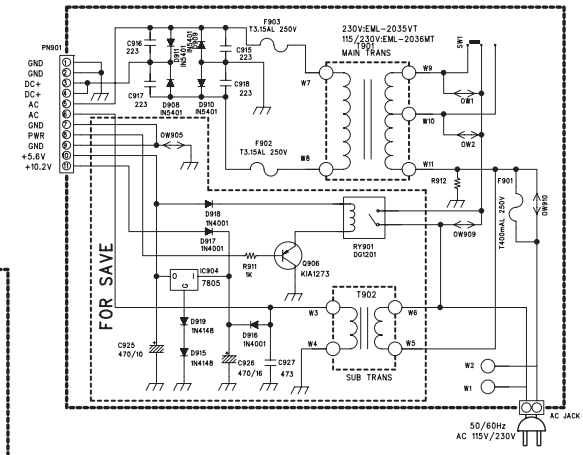

# • TUNER SCHEMATIC DIAGRAM

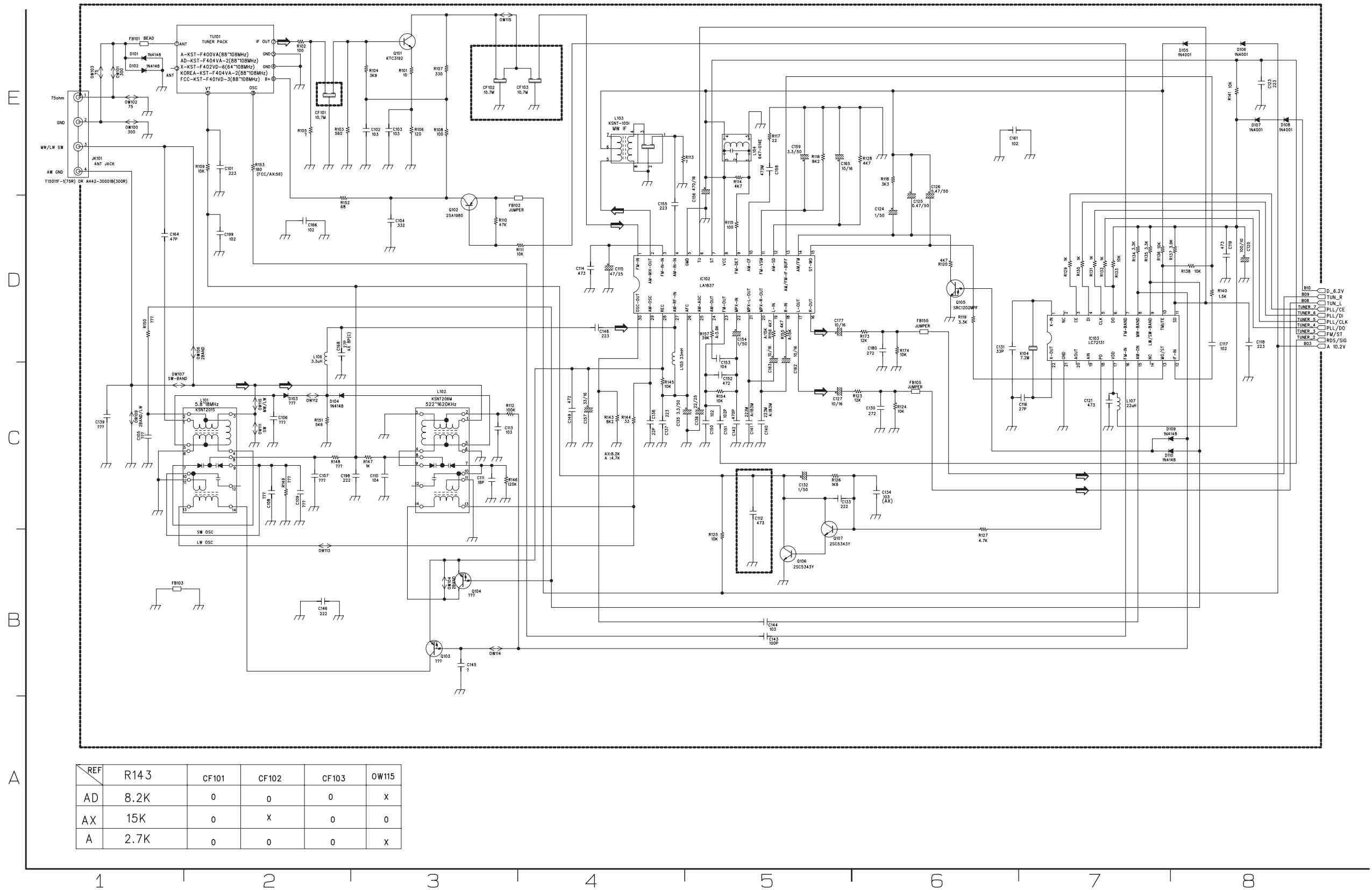

# WIRING DIAGRAM

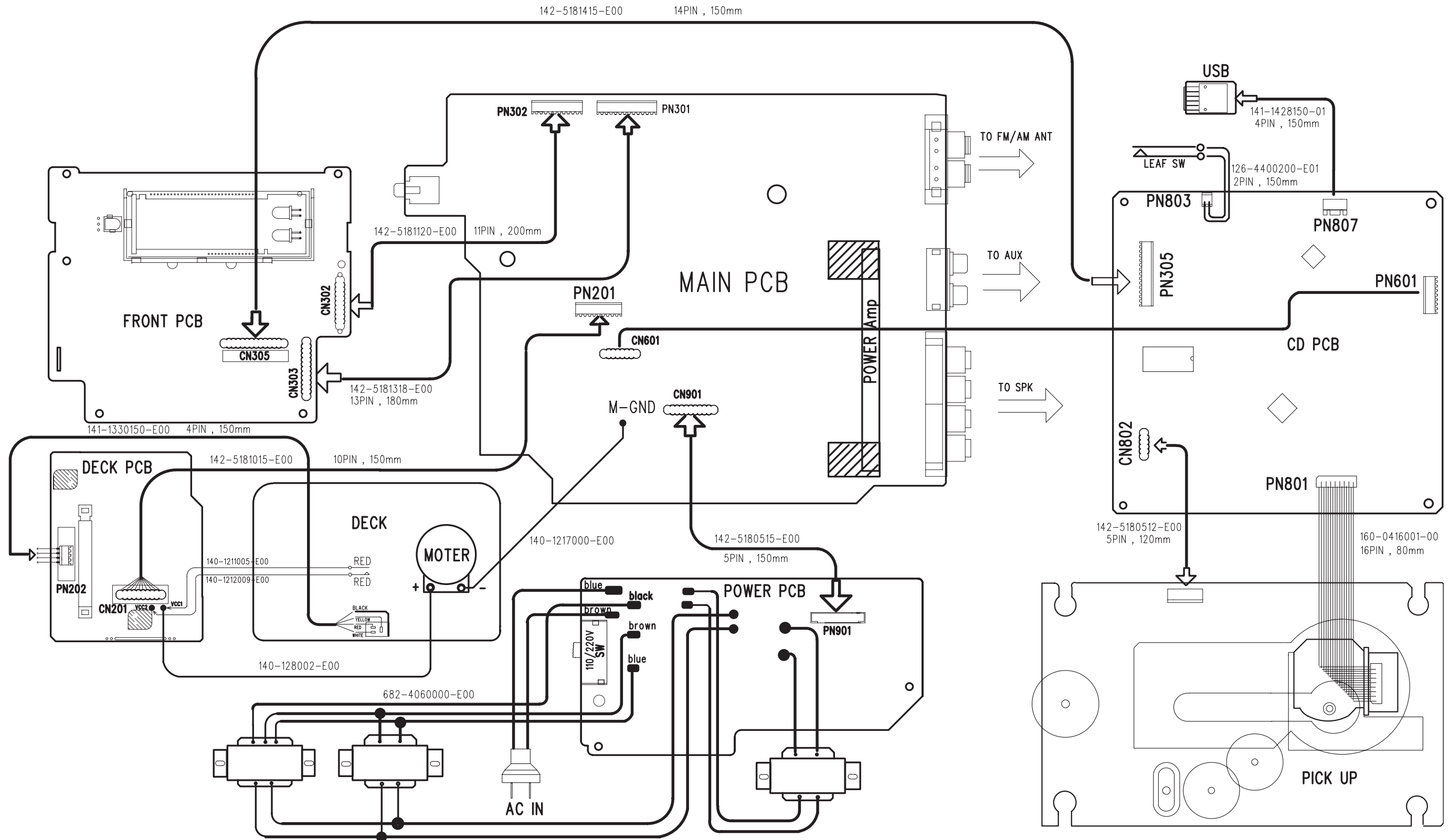

# PRINTED CIRCUIT DIAGRAMS

## FRONT, POWER & USB P.C. BOARD (Top View)

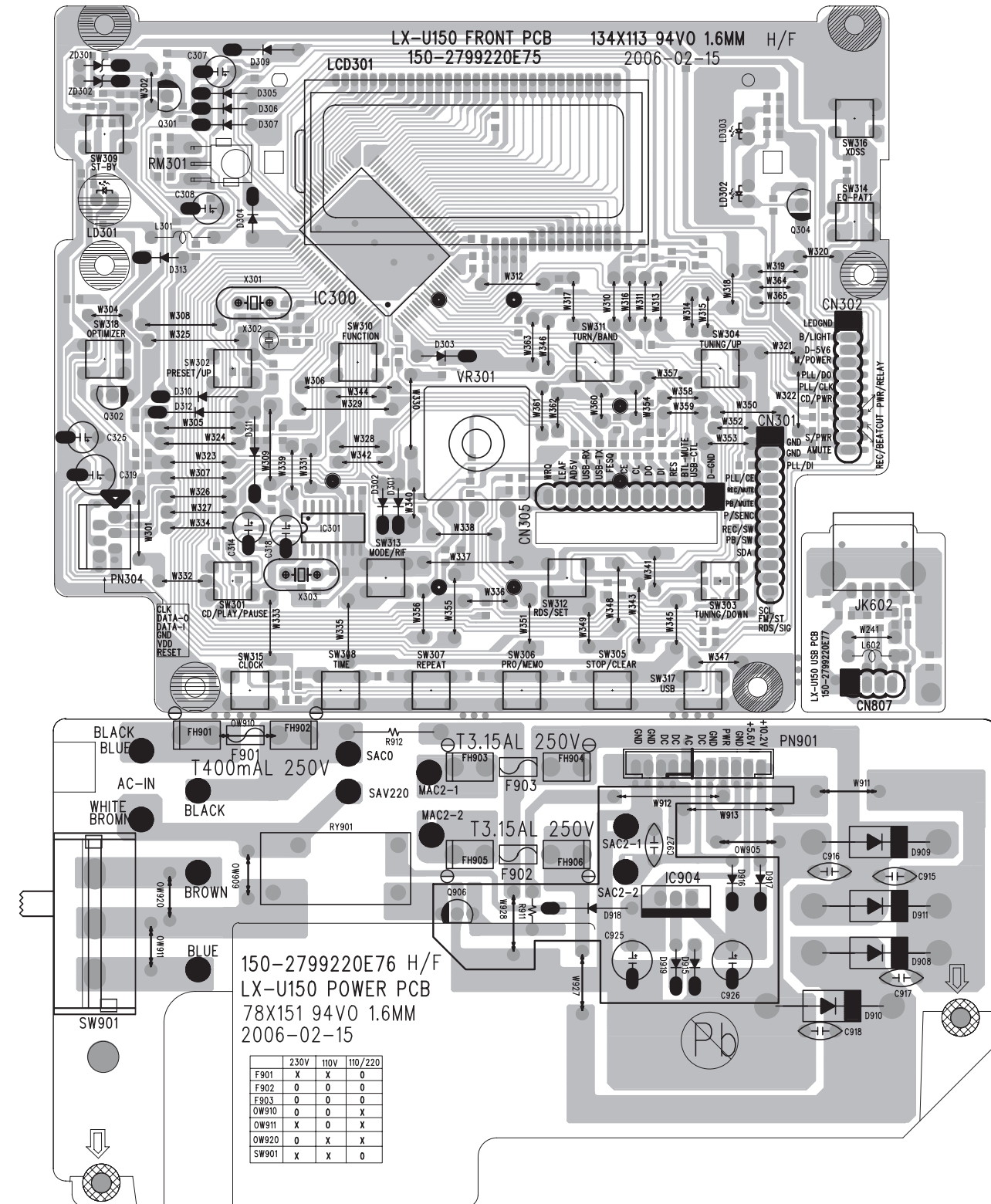

## FRONT, POWER & USB P.C. BOARD (Bottom View)

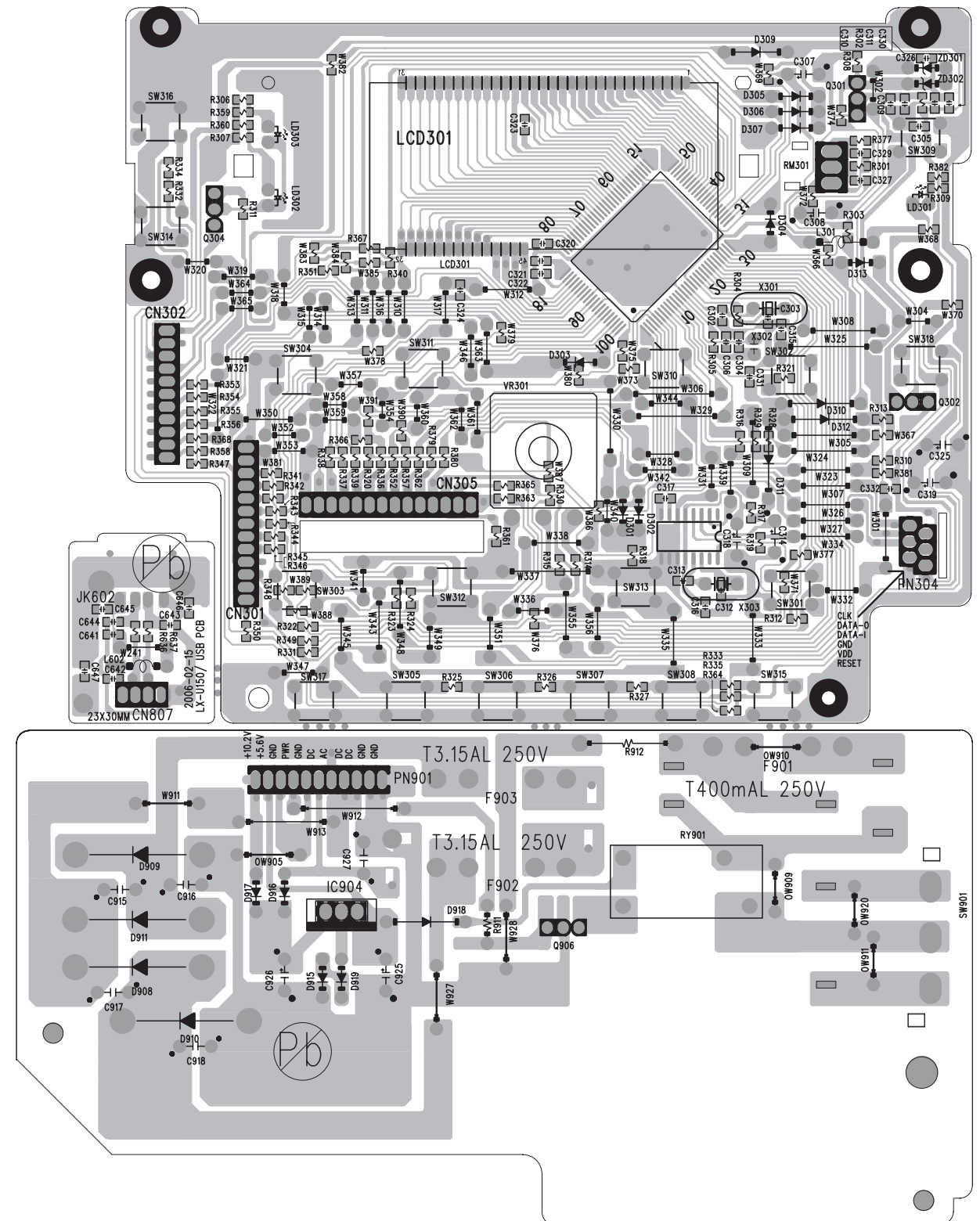







• MAIN/DECK P.C. BOARD (Bottom View)

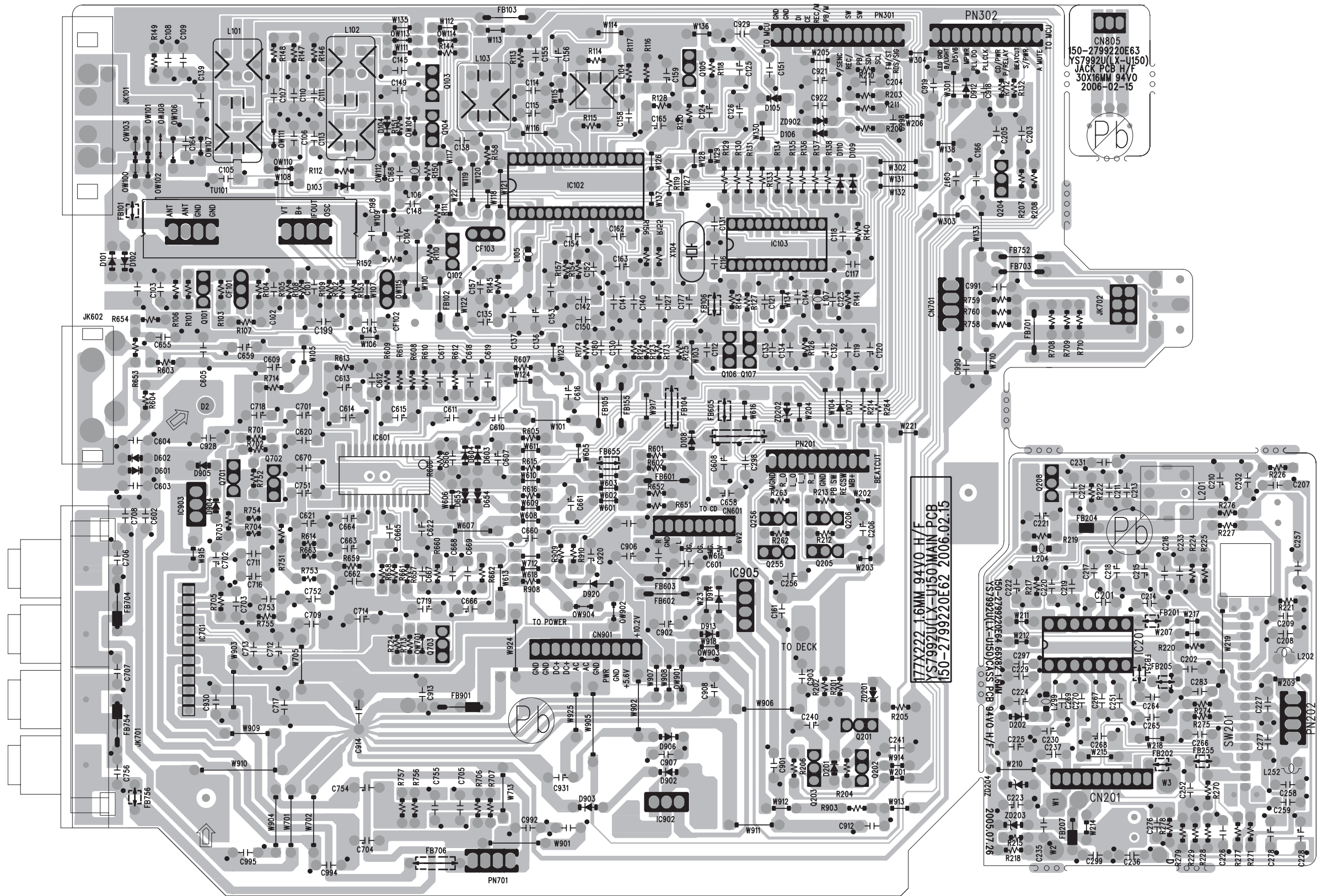

• CD P.C. BOARD(Top View)

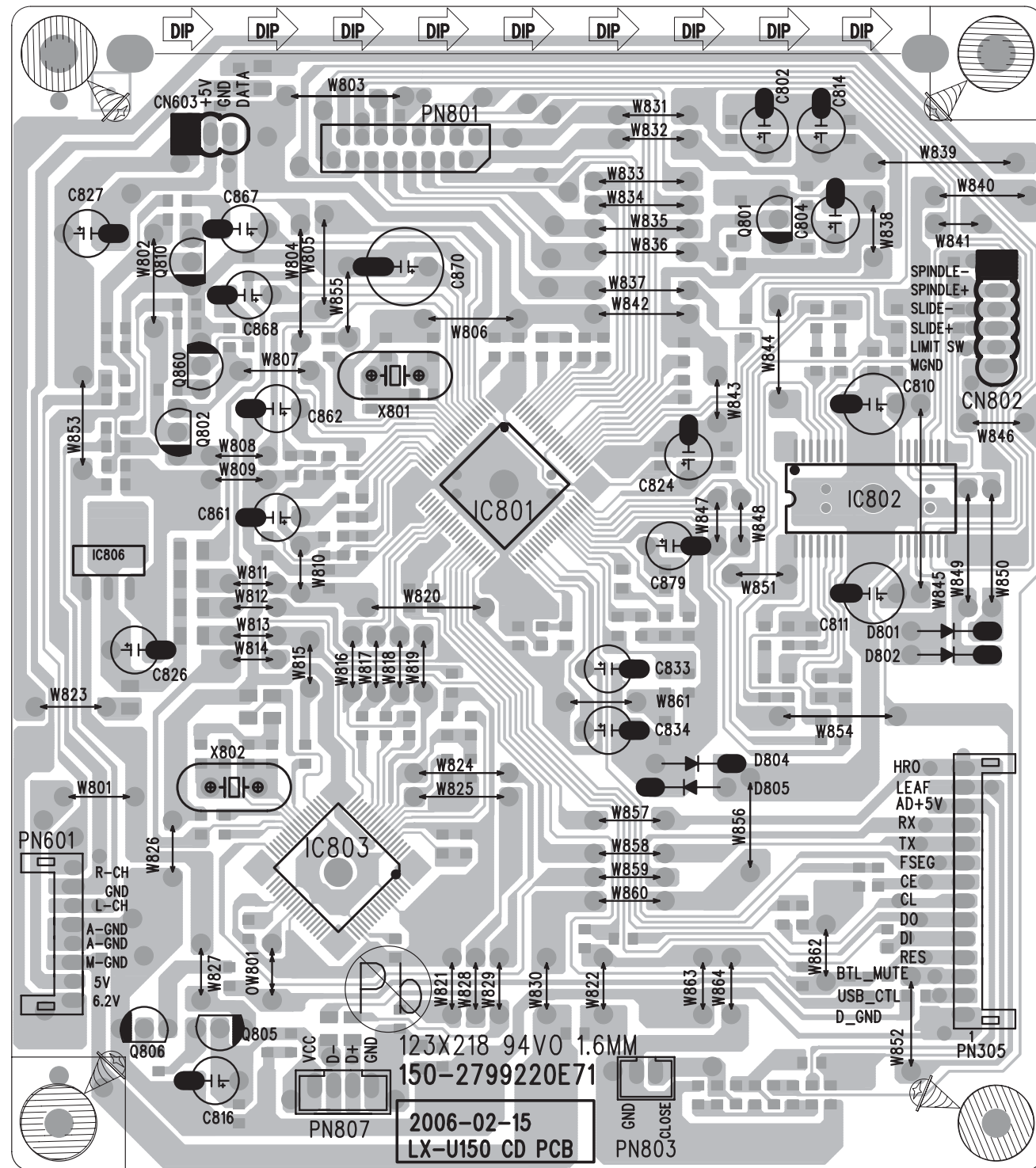

• CD P.C. BOARD(Bottom View)

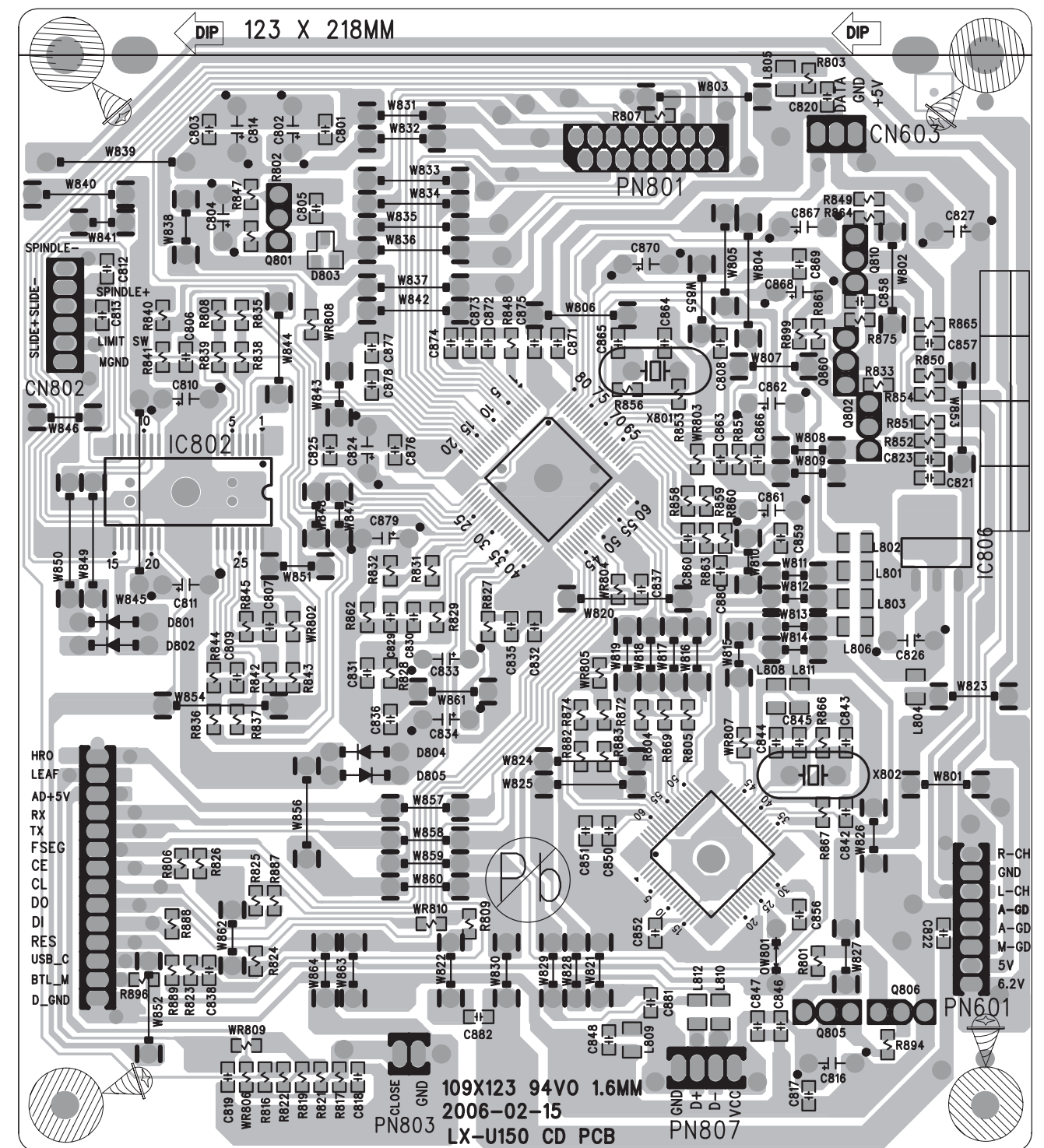



# INTERNAL BLOCK DIAGRAM OF ICs

## IC300 LC877B80A

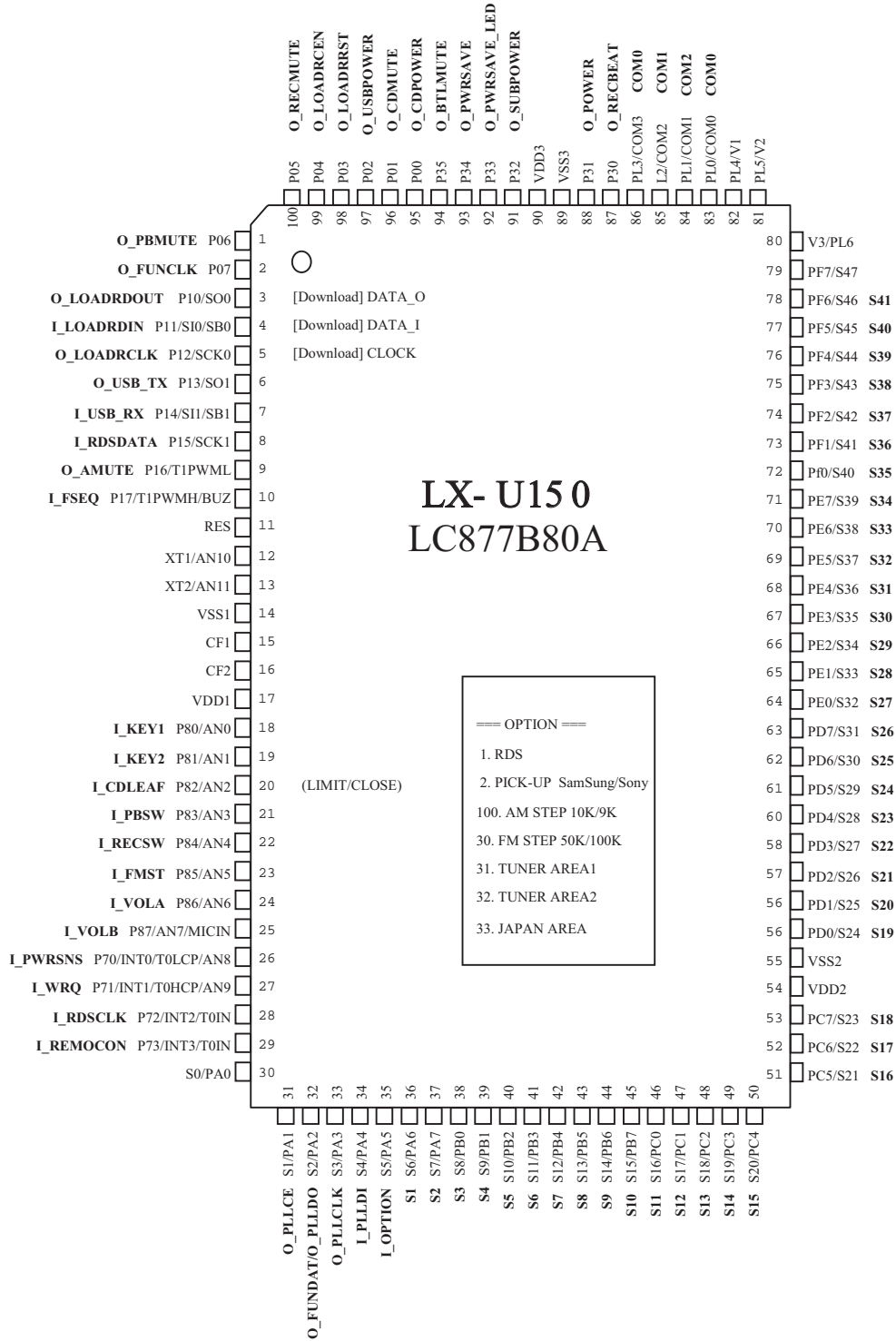



# IC601 TDA7468D

## 1) BLOCK DIAGRAM

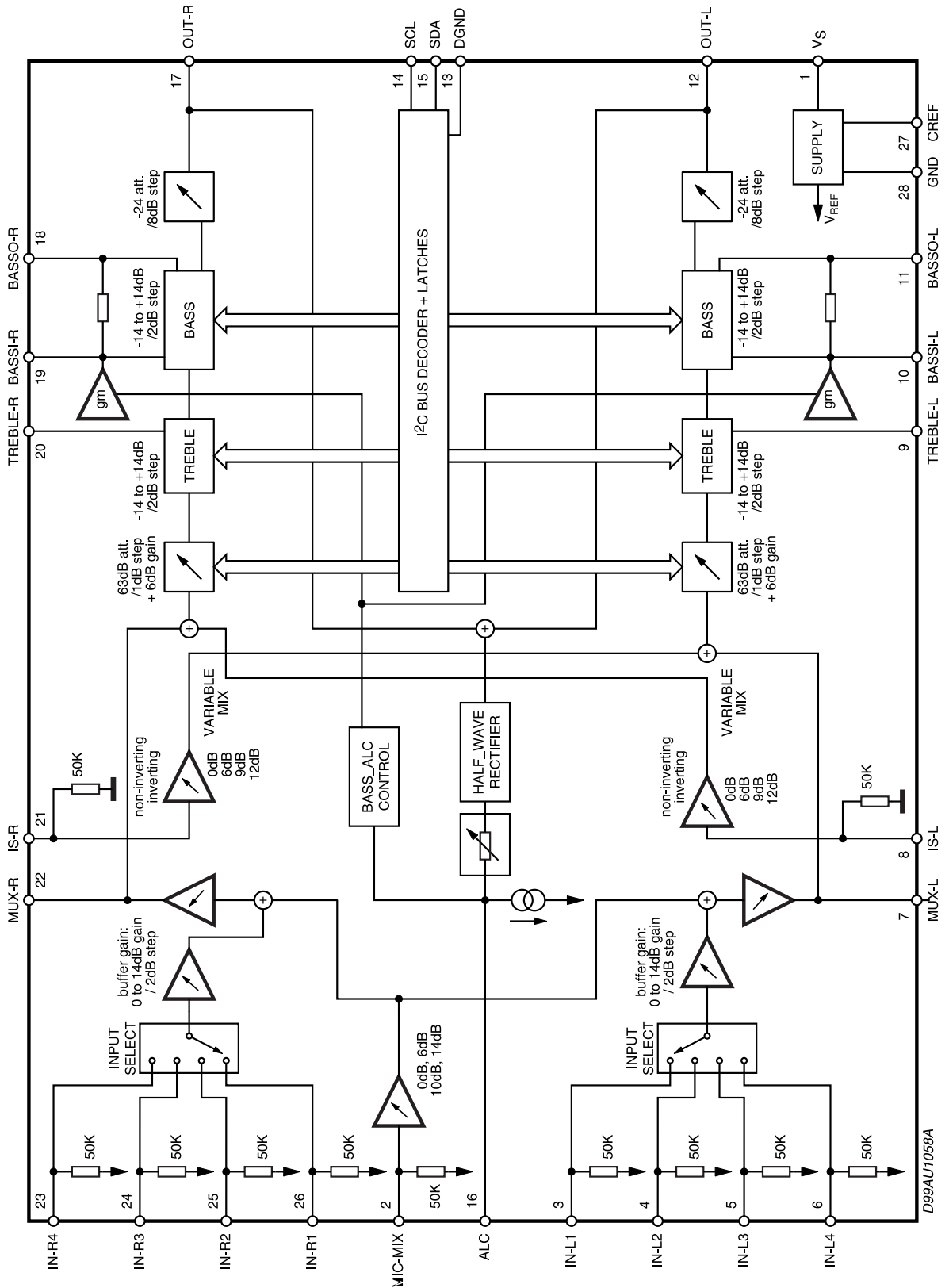

D99AU1058A

## 2) PIN COFIGURATION

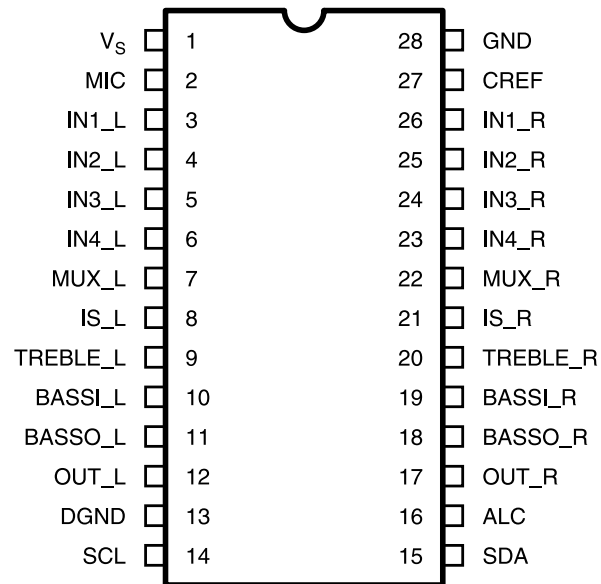

D99AU1057

# IC301 BU1923F

## 1) BLOCK DIAGRAM

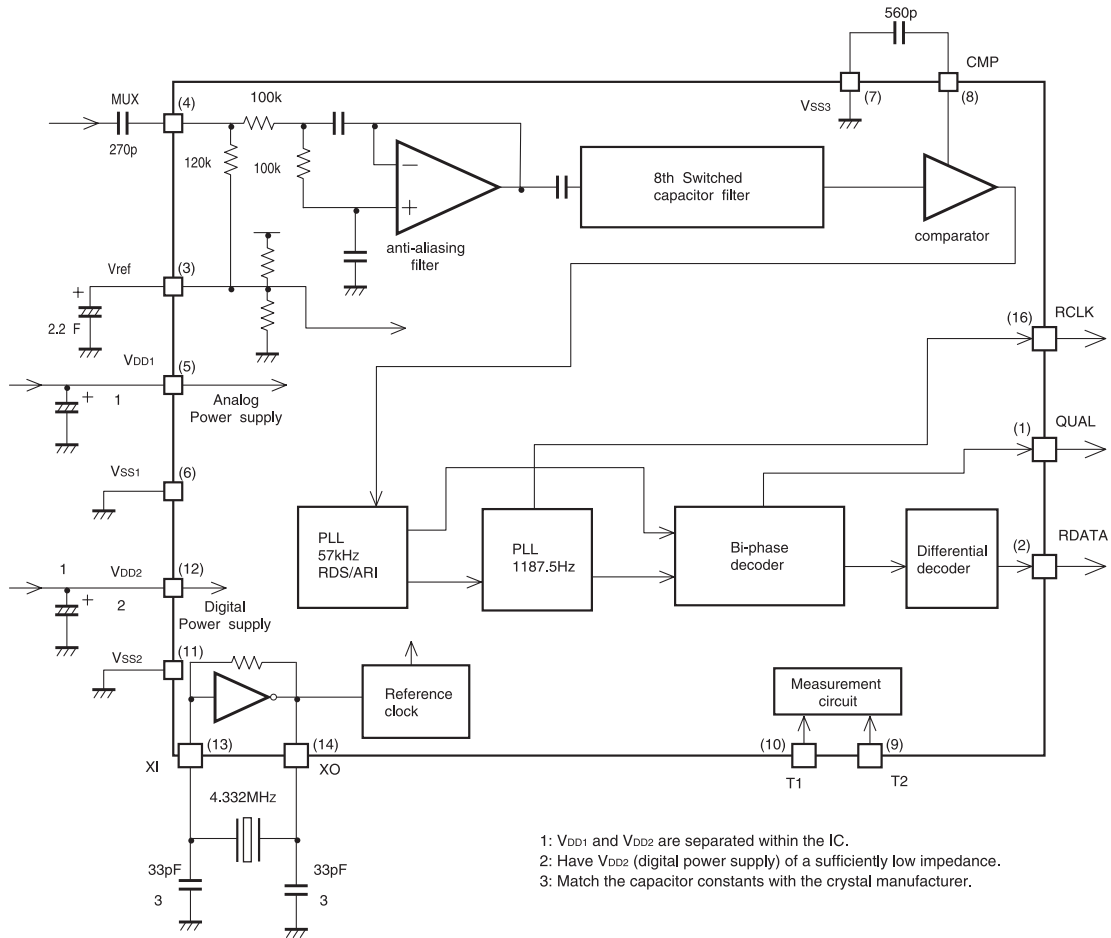

## 2) PIN COFIGURATION

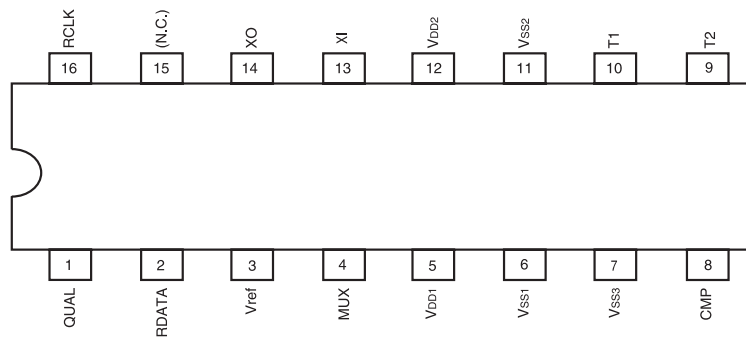

# IC102 LA1837

## 1) BLOCK DIAGRAM

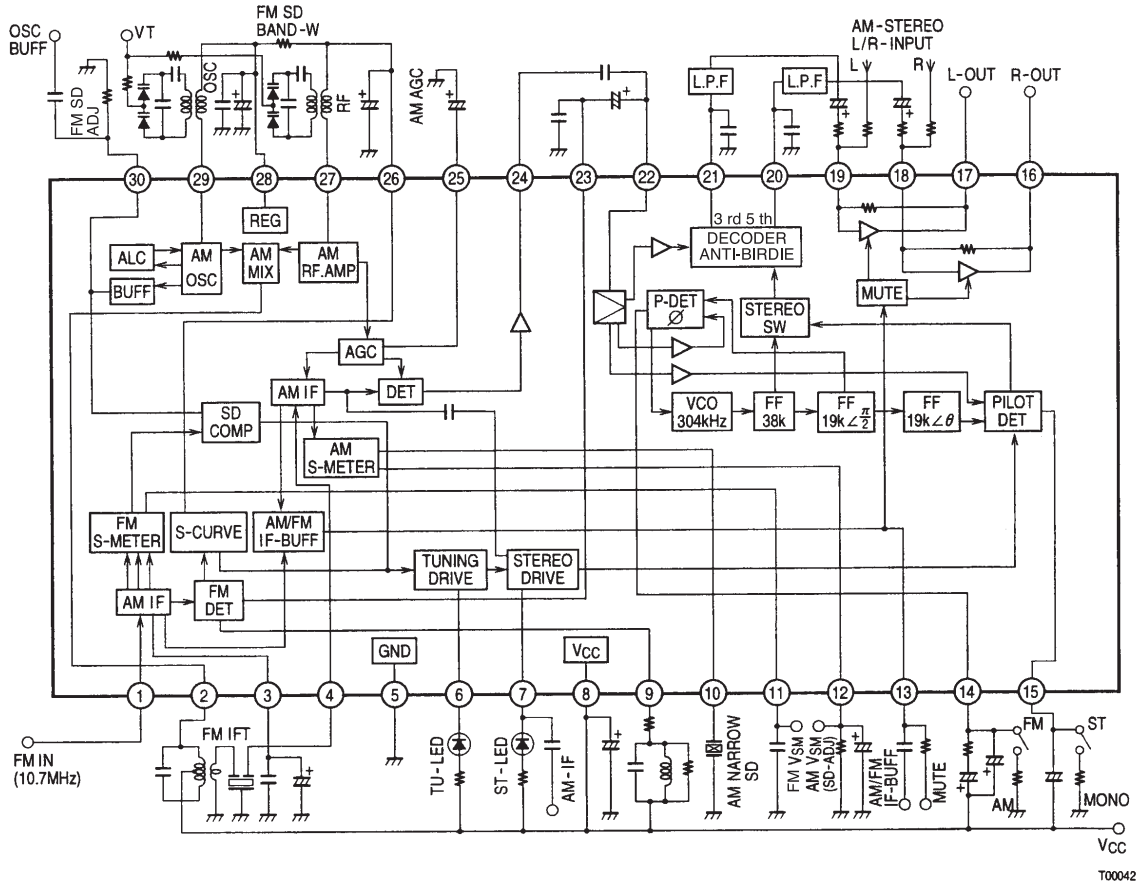

## 2) TEST CIRCUIT DIAGRAM

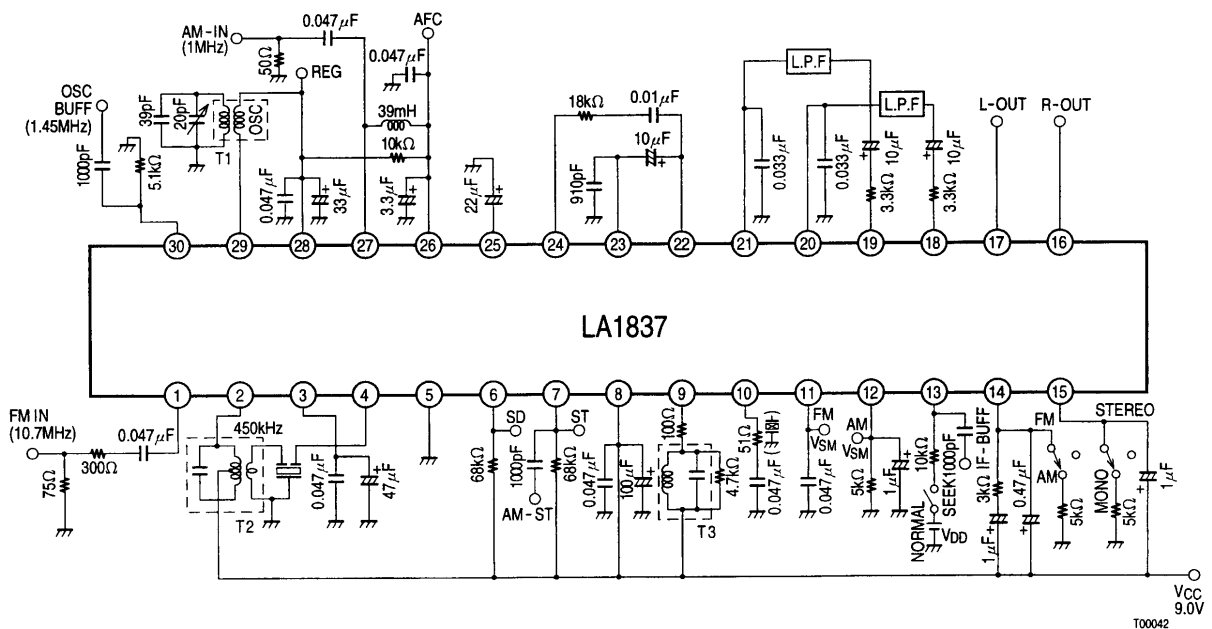

# IC103 LC72131

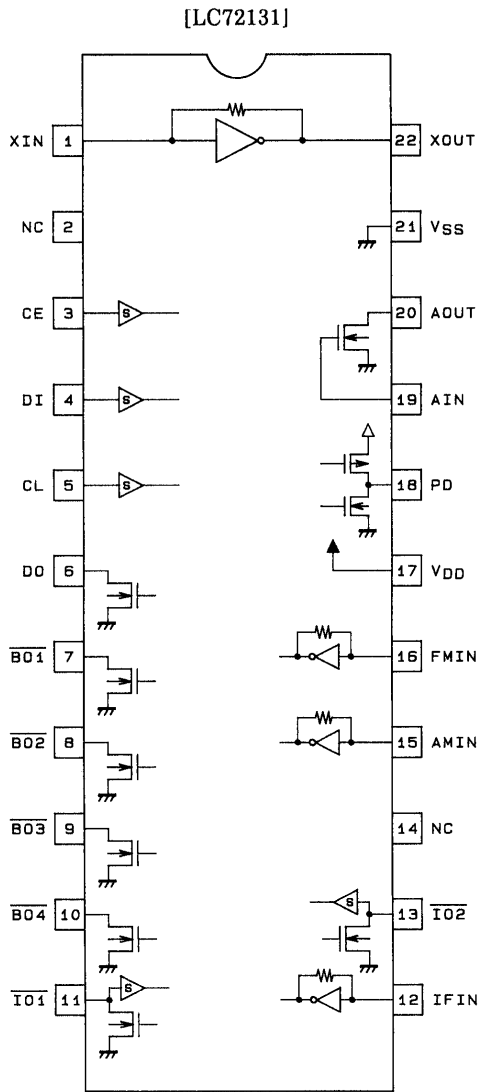

Top view

■ IC201 AN7312

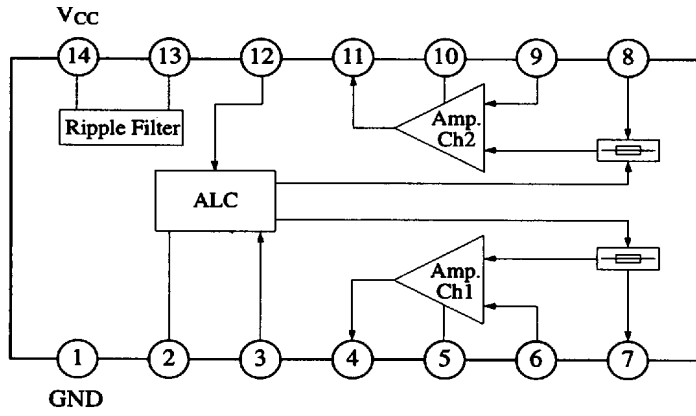

■ IC701 LA4631

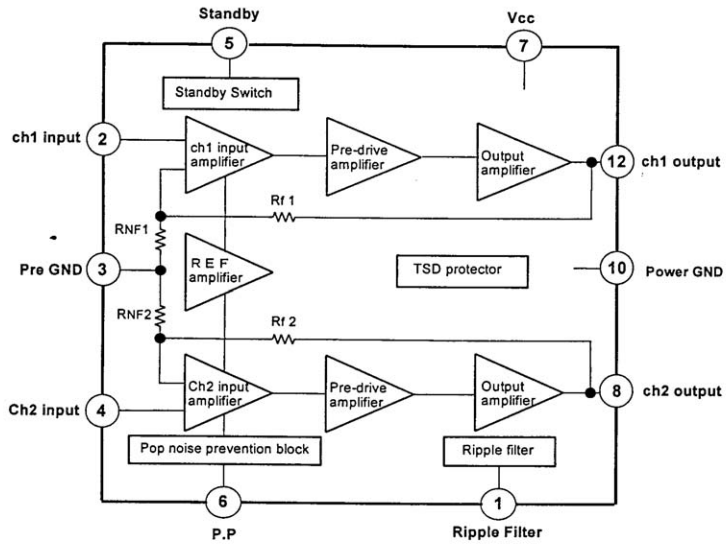

# IC503 SA5810

## 1) PIN COFIGURATION

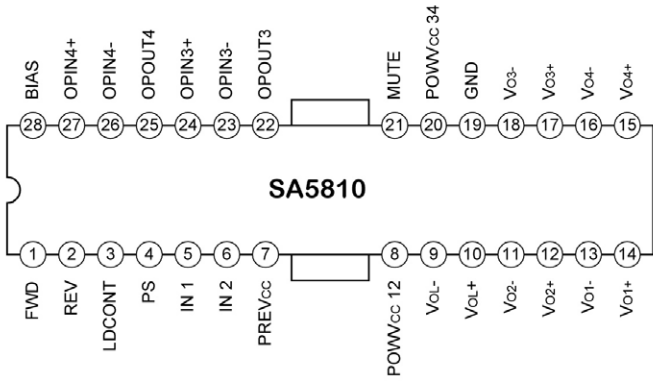

## 2)BLOCK DIAGRAM

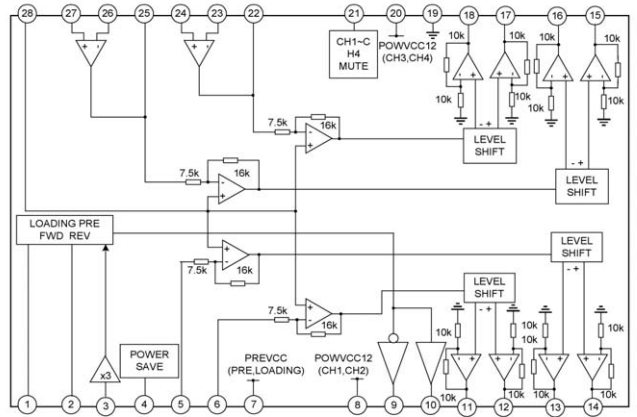

# IC801 LC78690W

## 1) PIN COFIGURATION

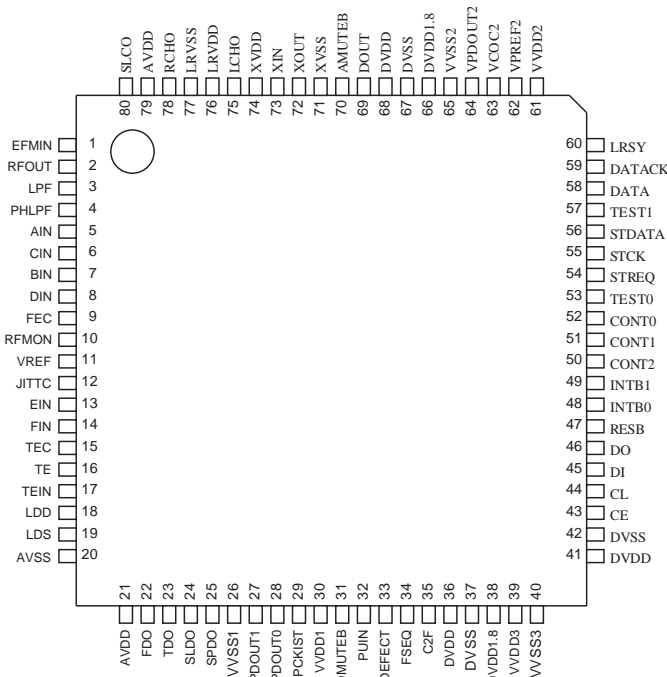

## 2)BLOCK DIAGRAM

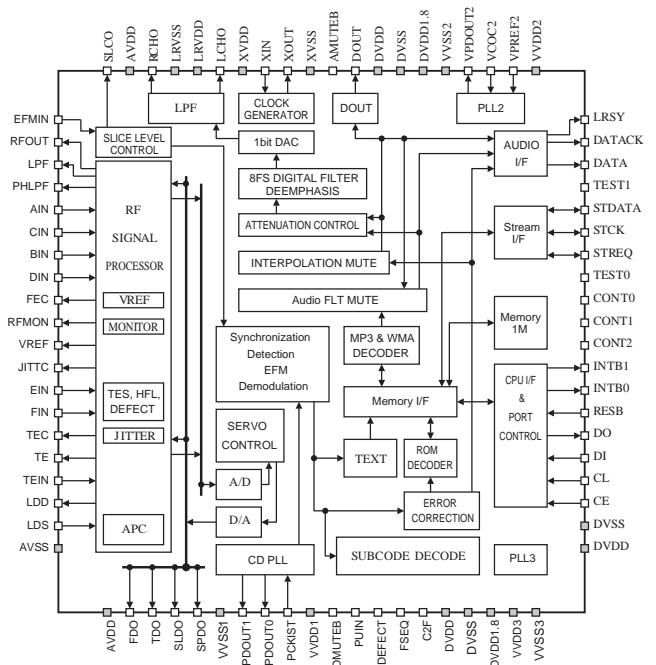

# SECTION 3. EXPLODED VIEWS

## CABINET AND MAIN FRAME SECTION

NOTE) Refer to "SECTION 5 REPLACEMENT PARTS LIST" in order to look for the part number of each part.

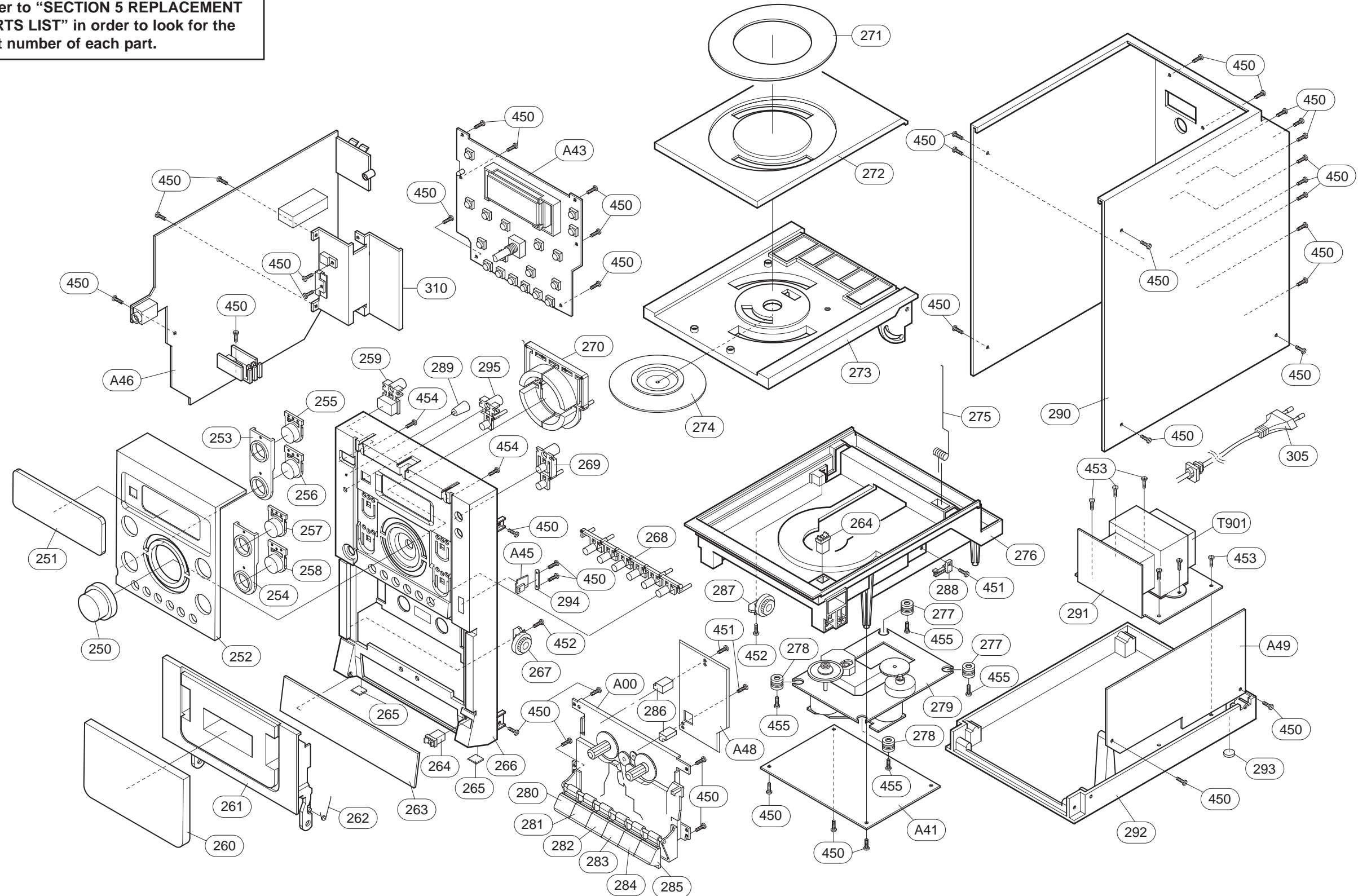



MEMO

MEMO

# SECTION 4. SPEAKER SECTION

□ MODEL: LXS-U150

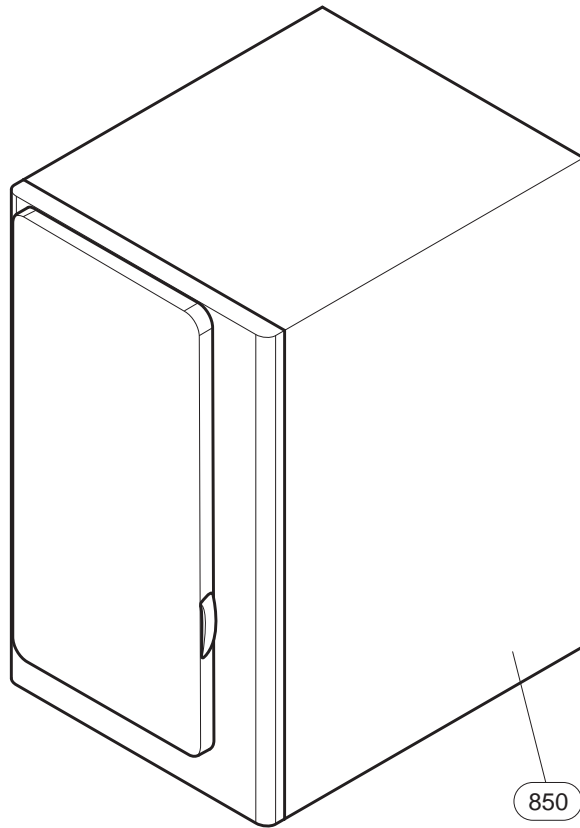

# MEMO