

SERVICE MANUAL MODEL: LX-U250A, LXS-U250

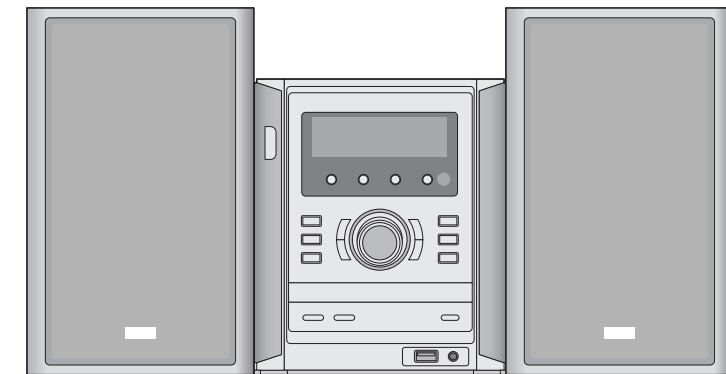

MICRO COMPONENT SYSTEM **SERVICE MANUAL**



MODEL: LX-U250A, LXS-U250

[CONTENTS]

○ SECTION 1. GENERAL

- SERVICING PRECAUTIONS 1-2
- ESD PRECAUTIONS 1-4
- SPECIFICATIONS 1-5

○ SECTION 2. ELECTRICAL

- TROUBLESHOOTING GUIDE 2-1
- WAVEFORMS OF MAKOR CHECK POINT 2-10
- INTERNAL BLOCK DIAGRAM of ICs 2-22
- BLOCK DIAGRAM 2-29
- SCHEMATIC DIAGRAMS 2-33
- WIRING DIAGRAM 2-45
- PRINTED CIRCUIT DIAGRAMS 2-47

○ SECTION 3. EXPLODED VIEWS

- CABINET AND MAIN FRAME SECTION 3-1
- SINGLE DECK MECHANISM 3-3
- CD MECHANISM 3-5

○ SECTION 4. SPEAKER SECTION

- MODEL: LXS-U250, LXS-W250 4-1

○ SECTION 5. REPLACEMENT PARTS LIST

- REPLACEMENT PARTS LIST 5-1

SECTION 1. GENERAL

SERVICING PRECAUTIONS

NOTES REGARDING HANDLING OF THE PICK-UP

1. Notes for transport and storage

- 1) The pick-up should always be left in its conductive bag until immediately prior to use.
- 2) The pick-up should never be subjected to external pressure or impact.

Storage in conductive bag

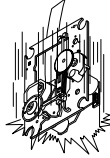
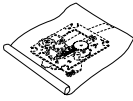

Drop impact

2. Repair notes

- 1) The pick-up incorporates a strong magnet, and so should never be brought close to magnetic materials.
- 2) The pick-up should always be handled correctly and carefully, taking care to avoid external pressure and impact. If it is subjected to strong pressure or impact, the result may be an operational malfunction and/or damage to the printed-circuit board.
- 3) Each and every pick-up is already individually adjusted to a high degree of precision, and for that reason the adjustment point and installation screws should absolutely never be touched.
- 4) Laser beams may damage the eyes!
Absolutely never permit laser beams to enter the eyes!
Also NEVER switch ON the power to the laser output part (lens, etc.) of the pick-up if it is damaged.

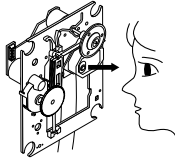

NEVER look directly at the laser beam, and don't let contact fingers or other exposed skin.

5) Cleaning the lens surface

If there is dust on the lens surface, the dust should be cleaned away by using an air bush (such as used for camera lens). The lens is held by a delicate spring. When cleaning the lens surface, therefore, a cotton swab should be used, taking care not to distort this.

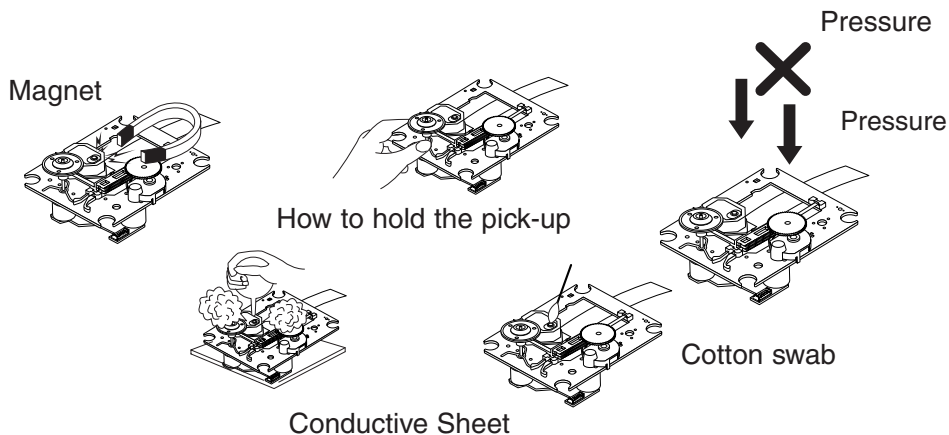

6) Never attempt to disassemble the pick-up.

Spring by excess pressure. If the lens is extremely dirty, apply isopropyl alcohol to the cotton swab. (Do not use any other liquid cleaners, because they will damage the lens.) Take care not to use too much of this alcohol on the swab, and do not allow the alcohol to get inside the pick-up.

• NOTES REGARDING COMPACT DISC PLAYER REPAIRS

1. Preparations

- 1) Compact disc players incorporate a great many ICs as well as the pick-up (laser diode). These components are sensitive to, and easily affected by, static electricity. If such static electricity is high voltage, components can be damaged, and for that reason components should be handled with care.
- 2) The pick-up is composed of many optical components and other high-precision components. Care must be taken, therefore, to avoid repair or storage where the temperature or humidity is high, where strong magnetism is present, or where there is excessive dust.

2. Notes for repair

- 1) Before replacing a component part, first disconnect the power supply lead wire from the unit
- 2) All equipment, measuring instruments and tools must be grounded.
- 3) The workbench should be covered with a conductive sheet and grounded.
When removing the laser pick-up from its conductive bag, do not place the pick-up on the bag. (This is because there is the possibility of damage by static electricity.)
- 4) To prevent AC leakage, the metal part of the soldering iron should be grounded.
- 5) Workers should be grounded by an armband (1M Ω)
- 6) Care should be taken not to permit the laser pick-up to come in contact with clothing, in order to prevent static electricity changes in the clothing to escape from the armband.
- 7) The laser beam from the pick-up should NEVER be directly facing the eyes or bare skin.

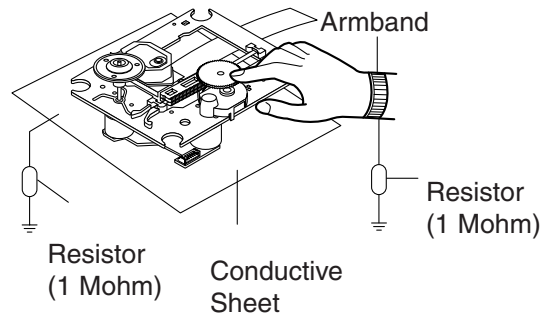

CLEARING MALFUNCTION

You can reset your unit to initial status if malfunction occur(button malfunction, display, etc.).

Using a pointed good conductor(such as driver), simply short the RESET jump wire on the inside of the volume knob for more than 3 seconds.

If you reset your unit, you must reenter all its settings(stations, clock, timer)

NOTE: 1. To operate the RESET jump wire, pull the volume rotary knob and release it.

2. If you wish to operate the RESET jump wire, it is necessary to unplug the power cord.

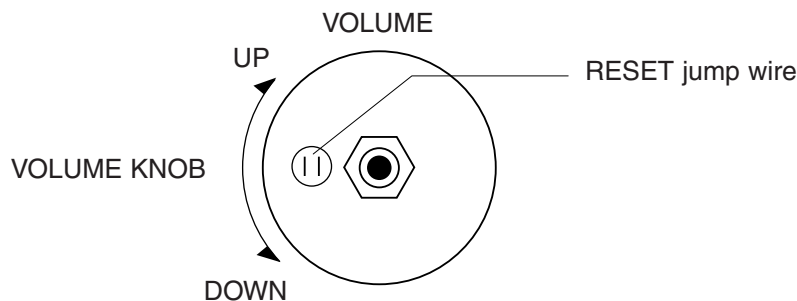

□ ESD PRECAUTIONS

• Electrostatically Sensitive Devices (ESD)



Some semiconductor (solid state) devices can be damaged easily by static electricity. Such components commonly are called Electrostatically Sensitive Devices (ESD). Examples of typical ESD devices are integrated circuits and some field-effect transistors and semiconductor chip components. The following techniques should be used to help reduce the incidence of component damage caused by static electricity.

1. Immediately before handling any semiconductor component or semiconductor-equipped assembly, drain off any electrostatic charge on your body by touching a known earth ground. Alternatively, obtain and wear a commercially available discharging wrist strap device, which should be removed for potential shock reasons prior to applying power to the unit under test.
2. After removing an electrical assembly equipped with ESD devices, place the assembly on a conductive surface such as aluminum foil, to prevent electrostatic charge buildup or exposure of the assembly.
3. Use only a grounded-tip soldering iron to solder or unsolder ESD devices.
4. Use only an anti-static solder removal device. Some solder removal devices not classified as "anti-static" can generate electrical charges sufficient to damage ESD devices.
5. Do not use freon-propelled chemicals. These can generate electrical charges sufficient to damage ESD devices.
6. Do not remove a replacement ESD device from its protective package until immediately before you are ready to install it. (Most replacement ESD devices are packaged with leads electrically shorted together by conductive foam, aluminum foil or comparable conductive materials).
7. Immediately before removing the protective material from the leads of a replacement ESD device, touch the protective material to the chassis or circuit assembly into which the device will be installed.

CAUTION : BE SURE NO POWER IS APPLIED TO THE CHASSIS OR CIRCUIT, AND OBSERVE ALL OTHER SAFETY PRECAUTIONS.

8. Minimize bodily motions when handing unpackaged replacement ESD devices. (Otherwise harmless motion such as the brushing together of your clothes fabric or the lifting of your foot from a carpeted floor can generate static electricity sufficient to damage an ESD device).

• CAUTION. GRAPHIC SYMBOLS

	THE LIGHTNING FLASH WITH APROWHEAD SYMBOL. WITHIN AN EQUILATERAL TRIANGLE, IS INTENDED TO ALERT THE SERVICE PERSONNEL TO THE PRESENCE OF UNINSULATED "DANGEROUS VOLTAGE" THAT MAY BE OF SUFFICIENT MAGNITUDE TO CONSTITUTE A RISK OF ELECTRIC SHOCK.
	THE EXCLAMATION POINT WITHIN AN EQUILATERAL TRIANGLE IS INTENDED TO ALERT THE SERVICE PERSONNEL TO THE PRESENCE OF IMPORTANT SAFETY INFORMATION IN SERVICE LITERATURE.

□ SPECIFICATIONS

[General]	Power supply	Refer to the back panel of the unit.	
	Power consumption	60W	
	Mass	4.4kg	
	External dimensions (W x H x D)	170 x 195 x 323mm	
[CD/VCD/DVD]	Laser	Semiconductor laser, wavelength 650 nm	
	Frequency response (audio)	40 - 18000 Hz	
	Signal-to-noise ratio (audio)	More than 70 dB (1 kHz)	
	Dynamic range (audio)	More than 70 dB	
	Harmonic distortion (audio)	0.7 % (1 kHz)	
[Tuner]	FM	Tuning Range	87.5-108.0MHz/65-74MHz, 87.5-108.0MHz
		Intermediate Frequency	10.7 MHz
		Signal to Noise Ratio (Mono/Stereo)	60/55 dB
		Frequency Response	60 - 10000 Hz
	AM (MW)	Tuning Range	522-1620kHz or 520 -1720kHz
		Intermediate Frequency	450kHz
		Signal to Noise Ratio	35dB
		Frequency Response	100 - 1800Hz
[Amplifier]	output Power	20+20 (6Ω x 2ch)	
	T.H.D	0.2%	
	Frequency Response	40Hz - 25KHz	
	Signal-to-noise ratio	80 dB	
[Speaker]	Type	2 Way 2 Speaker	
	Impedance	6Ω	
	Frequency Response	90 - 20000Hz	
	Sound Pressure Level	87 dB/W (1m)	
	Rated Input Power	20W	
	Max. Input Power	40W	
	Net Dimensions (W x H x D)	160 x 250 x 186 mm	
Net Weight	2.1Kg		
TAPE	Tape Speed	3 kHz ± 3%	
	Wow Flutter	0.25% (MTT -111, JIS-WTD)	
	F.F/REW. Time	120sec (C-60)	
	Frequency Response	250 - 8000Hz	
	Signal to Noise Ratio	43dB(P/B)/43dB(R/B)	
	Channel Separation	50dB(P/B)/45dB(R/P)	
	Erase Ratio	55dB (MTT-5511)	

NOTE : Specification are subject to change without notice in the course of product improvement.

SECTION 2. ELECTRICAL

TROUBLESHOOTING GUIDE

CD PART

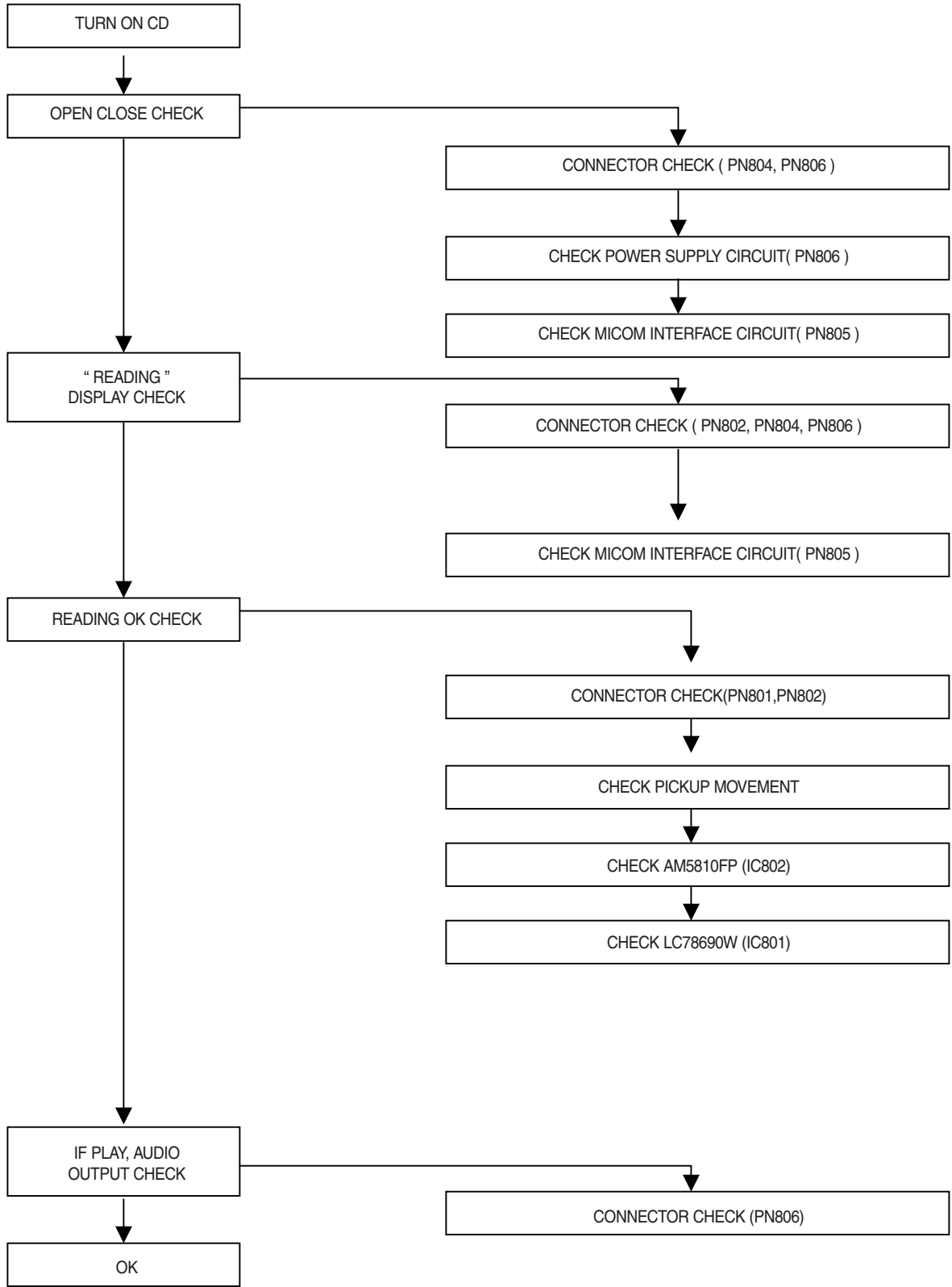

OPEN CLOSE NG

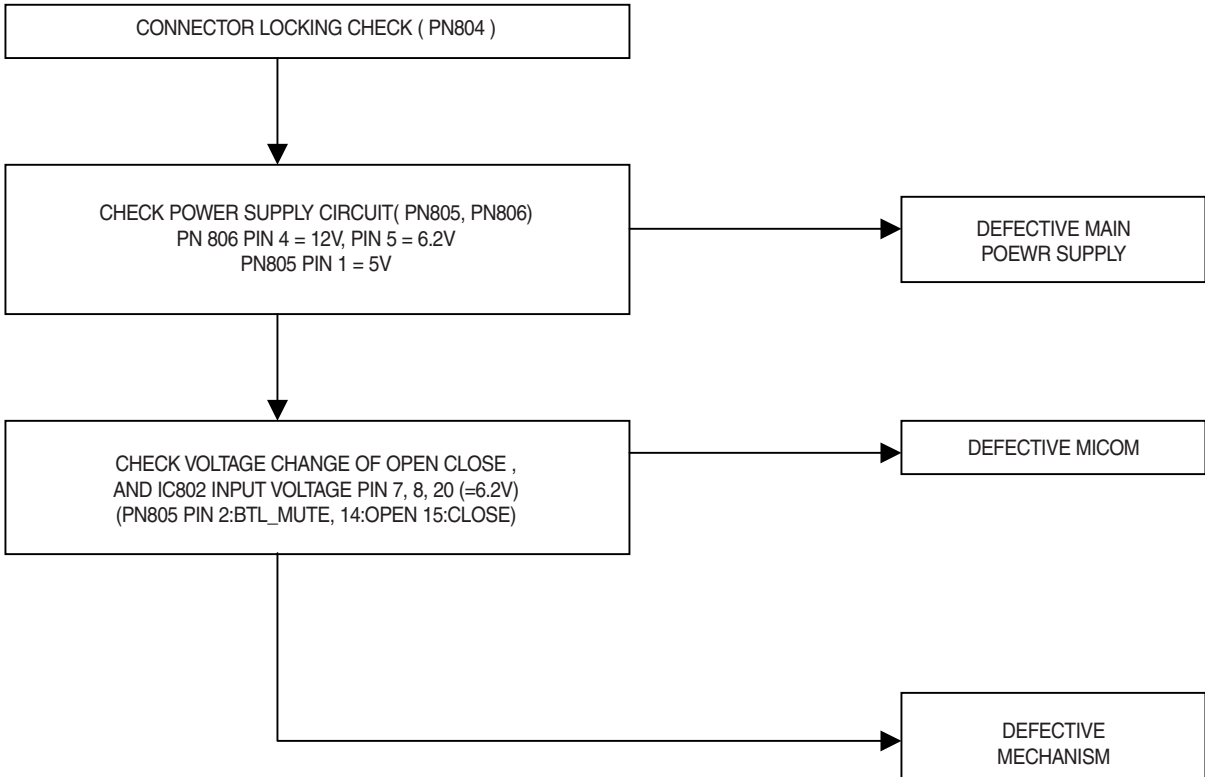

**“ READING ” DISPLAY CHECK
(= ONLY “CD “DISPLAY)**

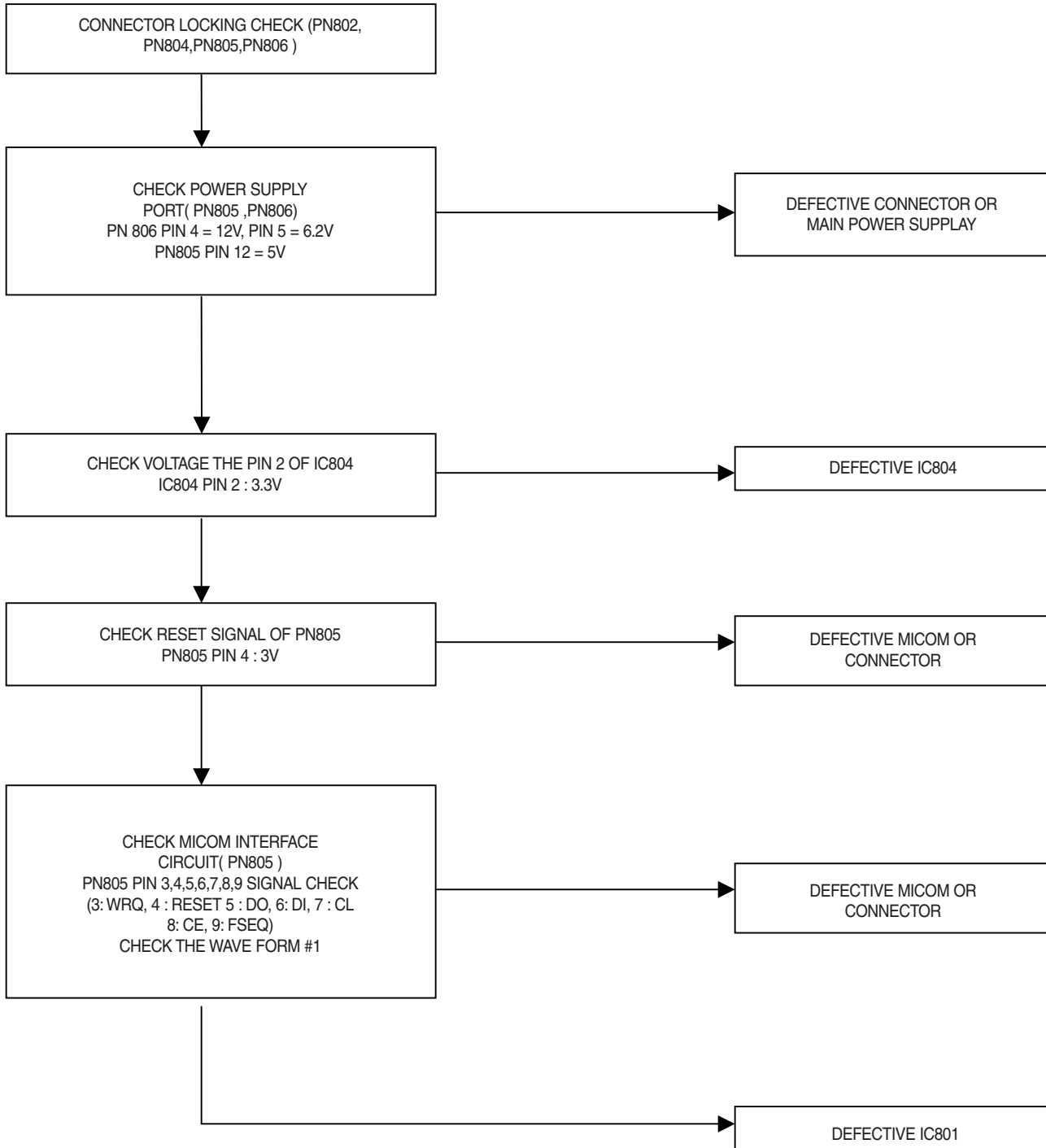

**READING OK CHECK
(= "NO DISC" DISPLAY)**

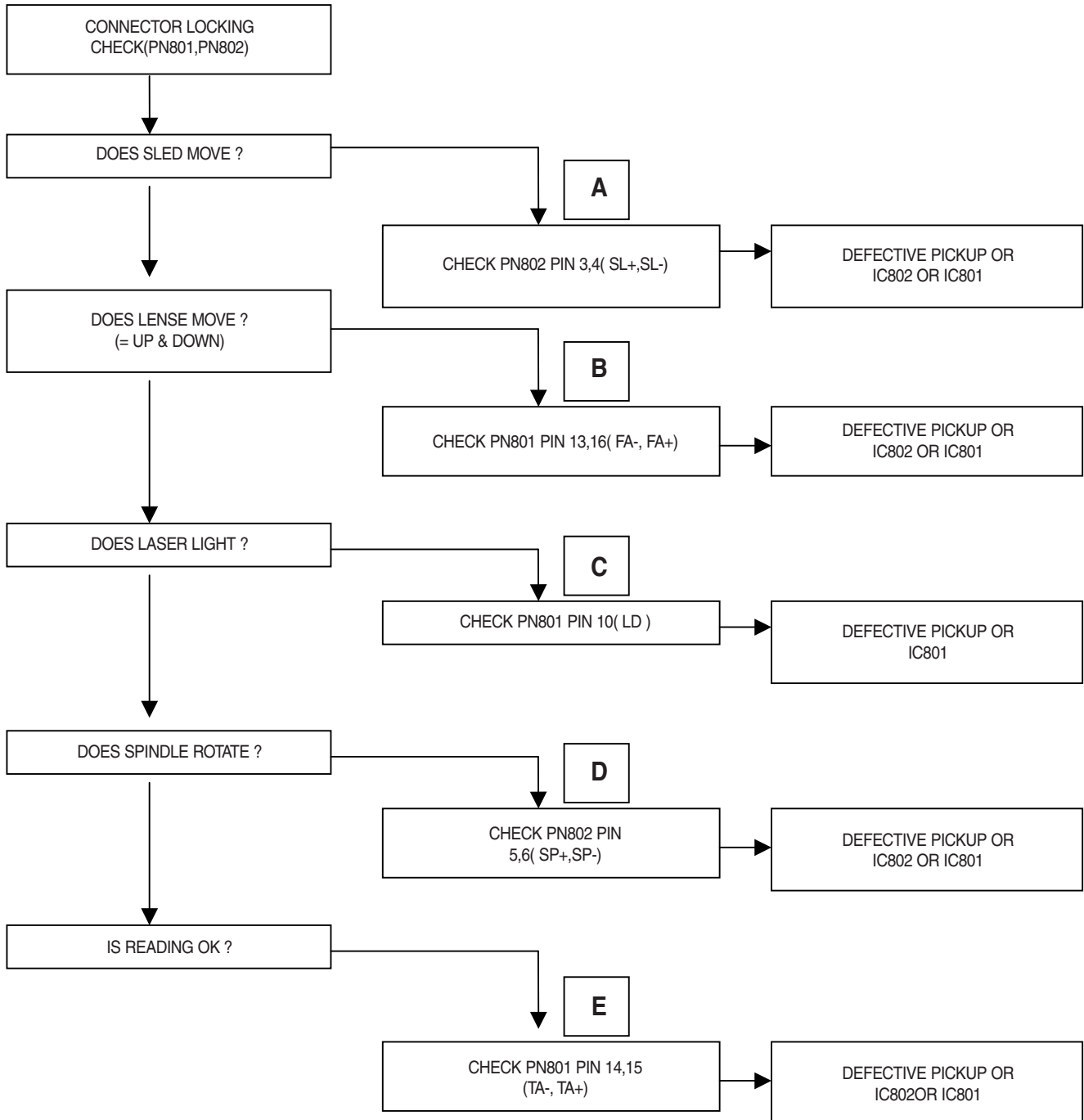

**READING OK CHECK #A
(= "NO DISC" DISPLAY)**

A

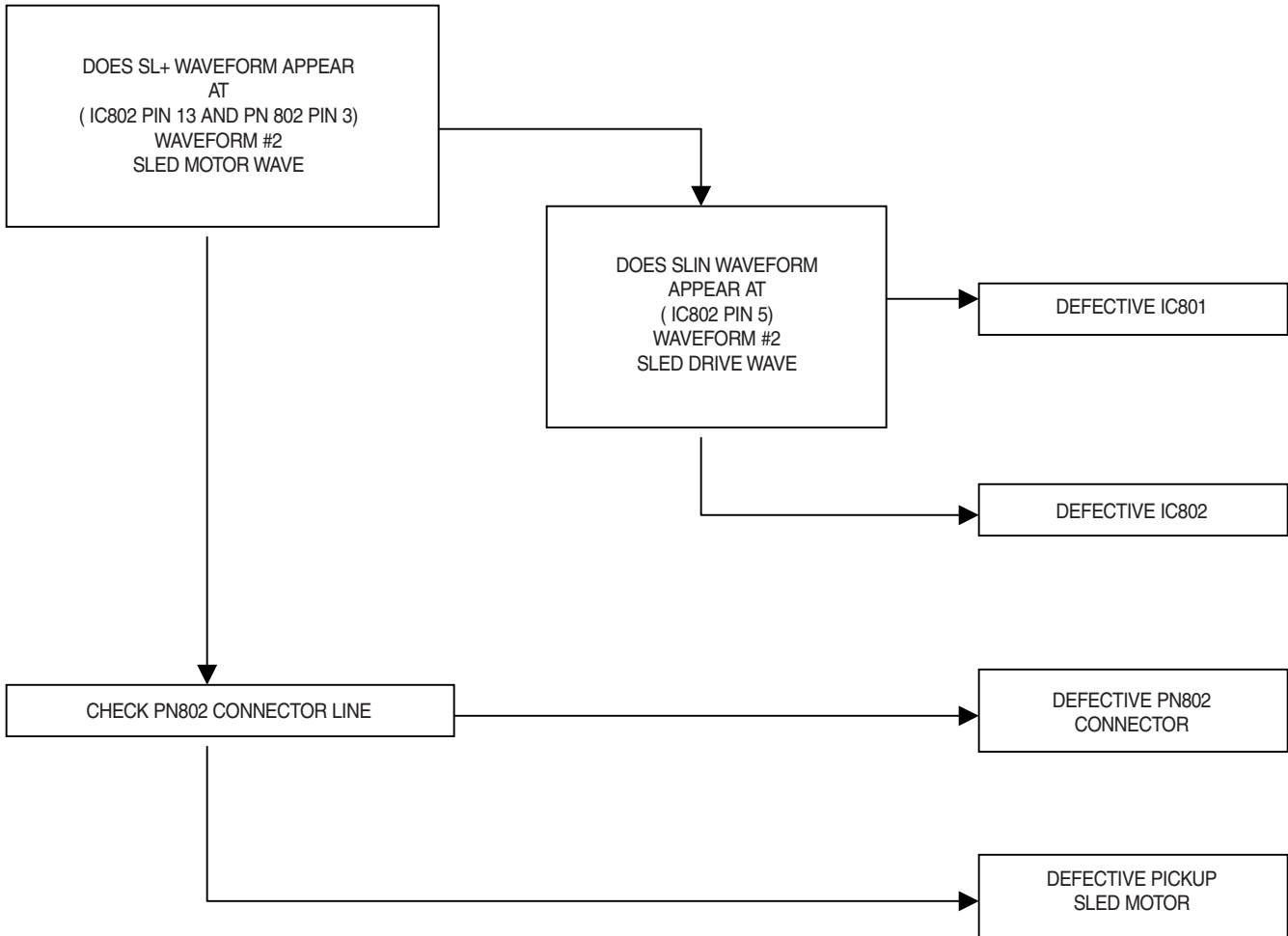

**READING OK CHECK #B
(= "NO DISC" DISPLAY)**

B

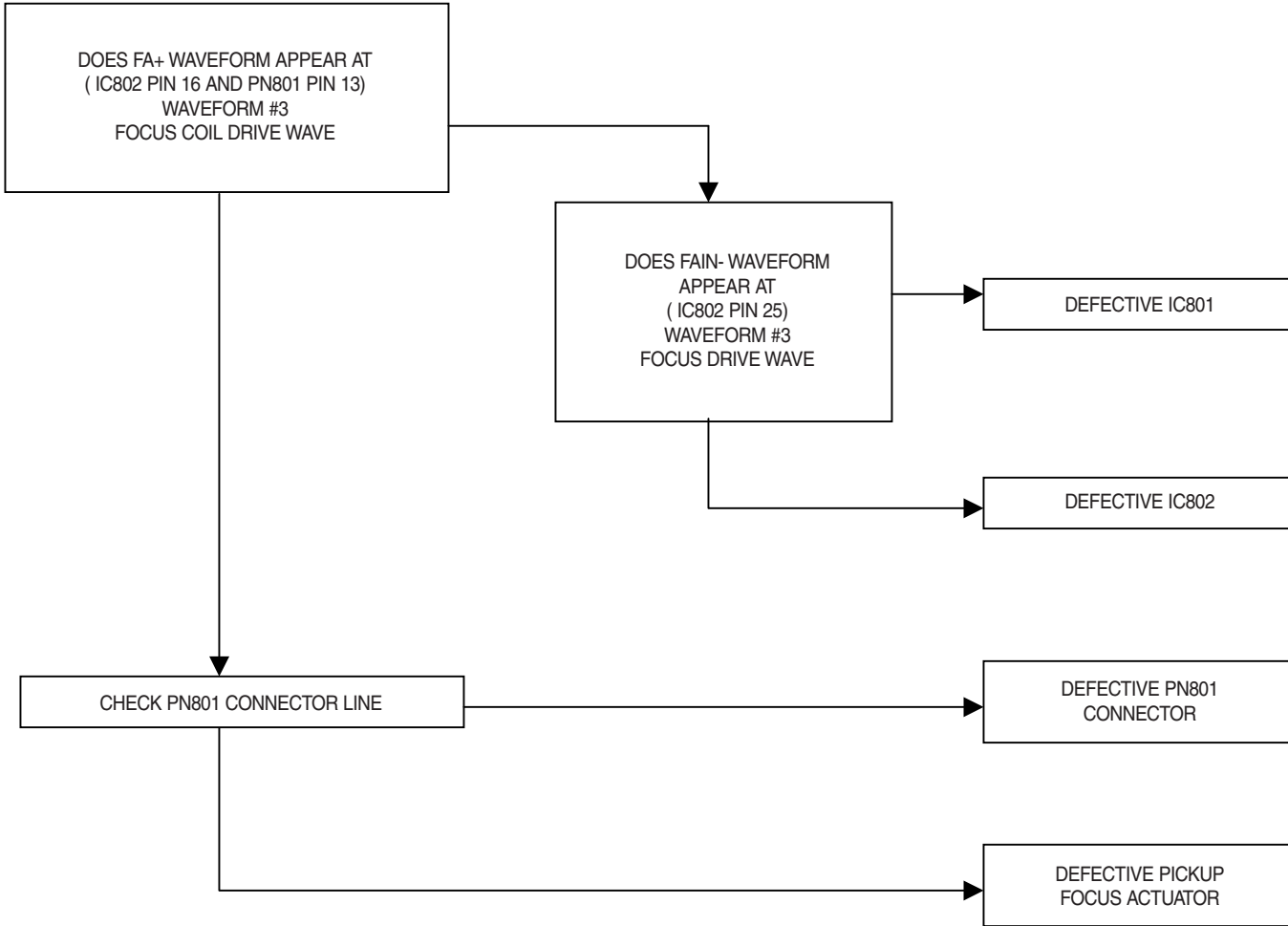

**READING OK CHECK #C
(= "NO DISC" DISPLAY)**

C

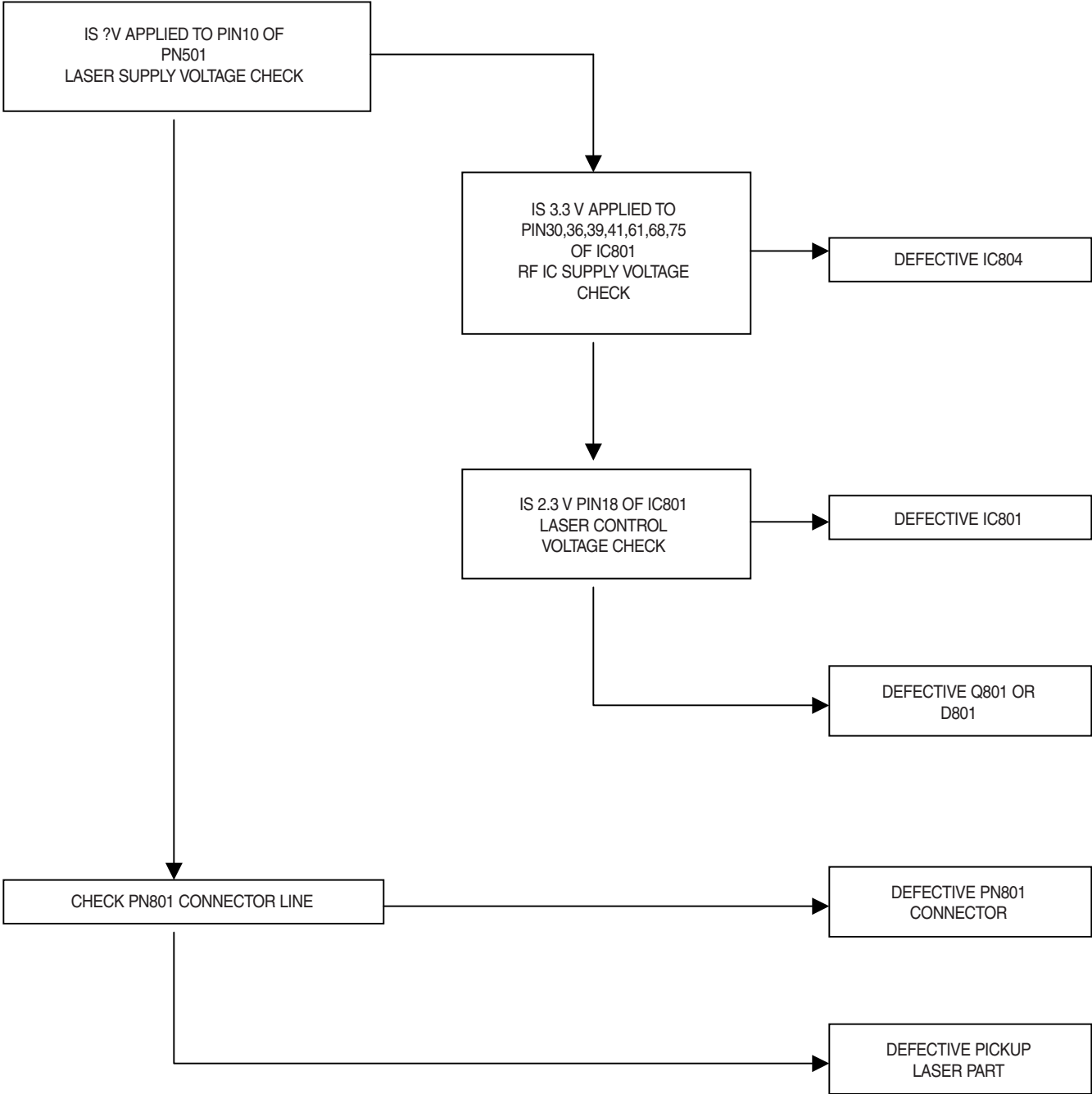

**READING OK CHECK #D
(= "NO DISC" DISPLAY)**

D

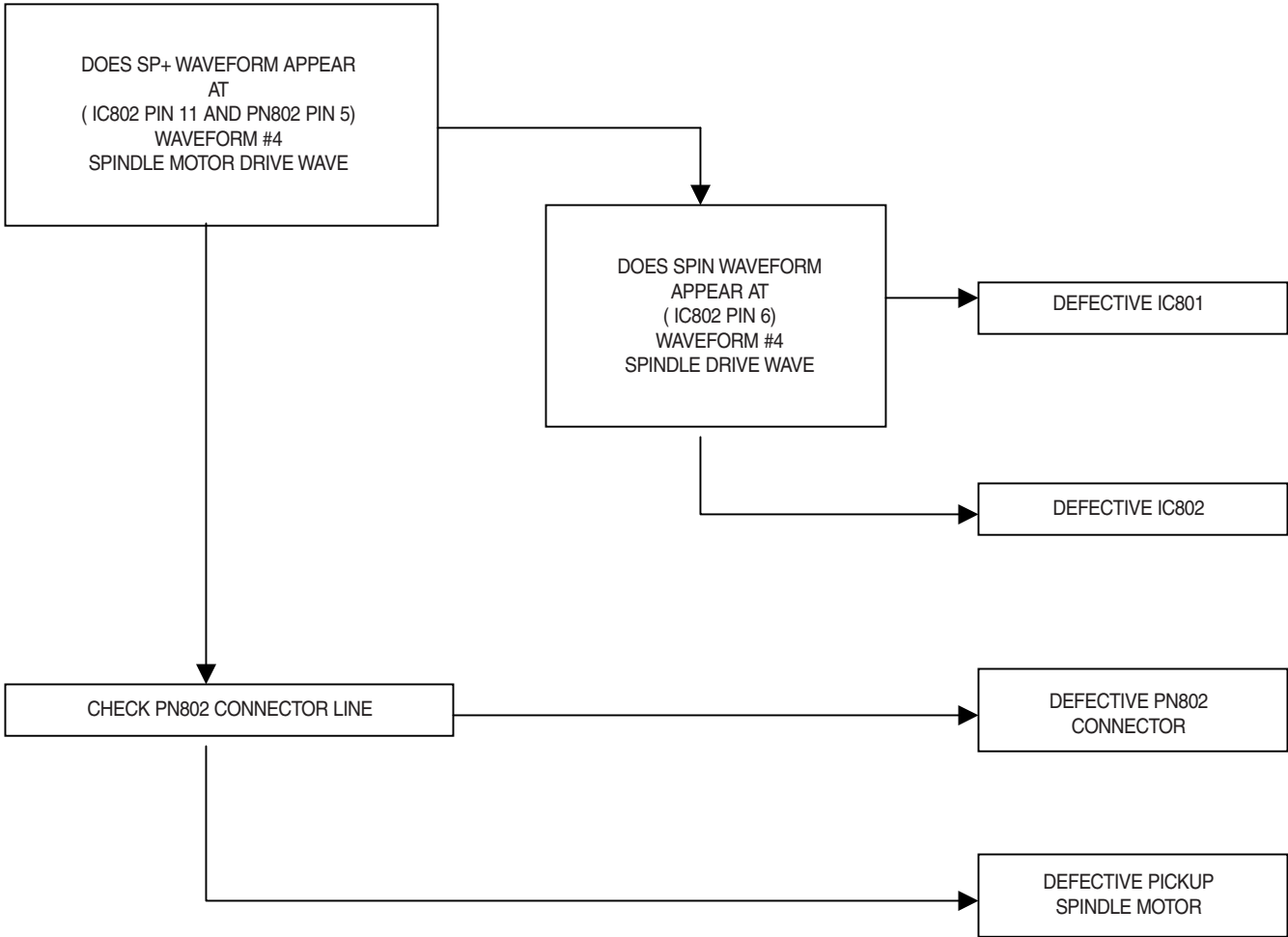

**READING OK CHECK #E
(= "NO DISC" DISPLAY)**

E

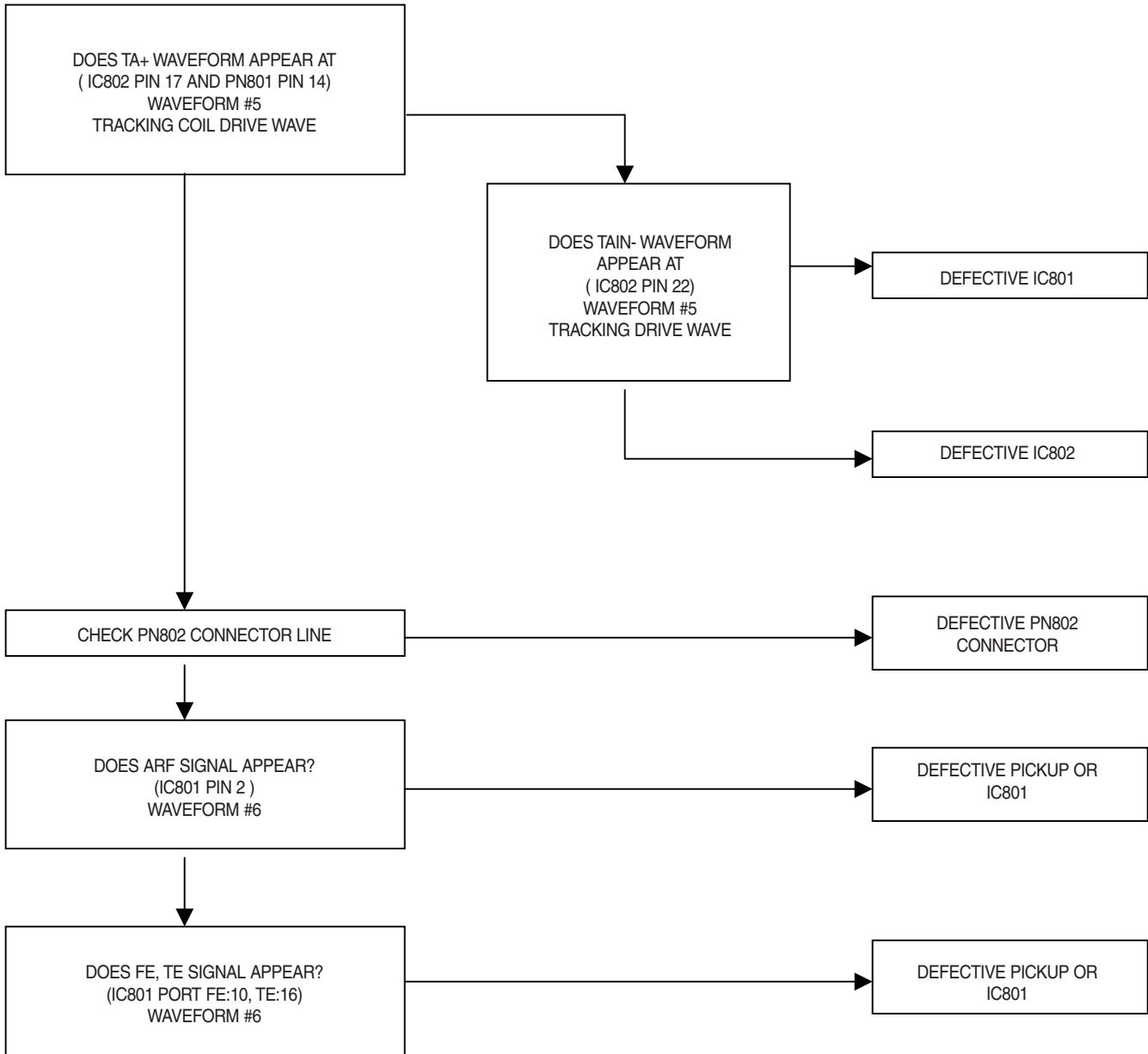

□ WAVEFORMS OF MAKOR CHECK POINT

#1. MICOM INTERFACE WAVEFORM
(PN805 PIN 3, 4, 5, 6) during power on

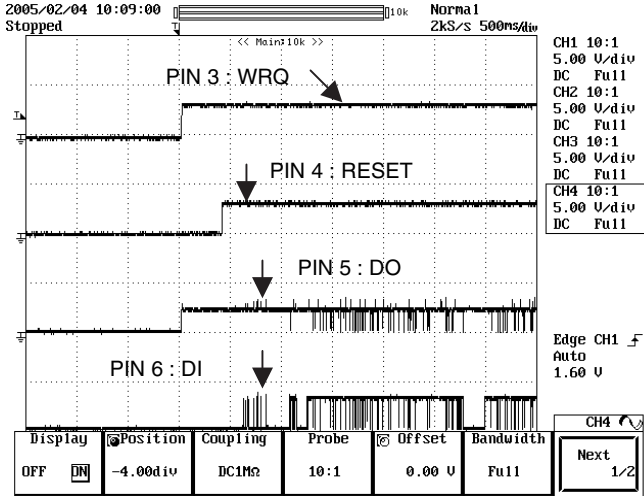

#1. MICOM INTERFACE WAVEFORM
(PN805 PIN 3, 4, 5, 6) during normal play

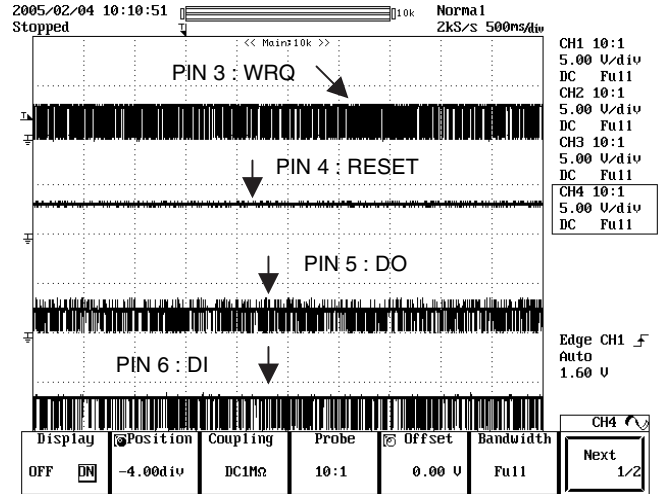

#1. MICOM INTERFACE WAVEFORM
(PN805 PIN 7, 8, 9) during power on

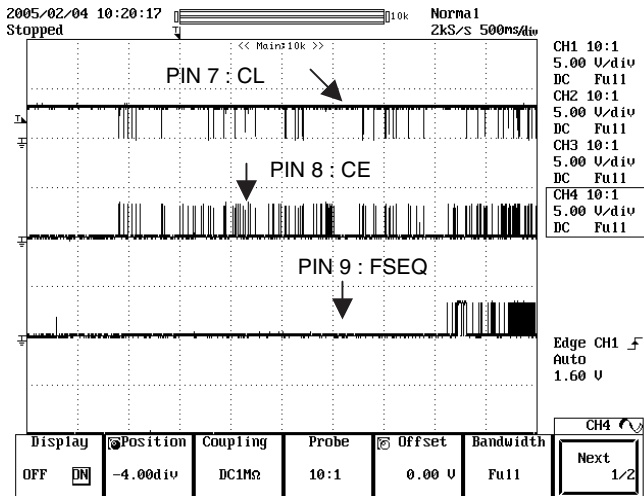

#1. MICOM INTERFACE WAVEFORM
(PN805 PIN 7, 8, 9) during normal play

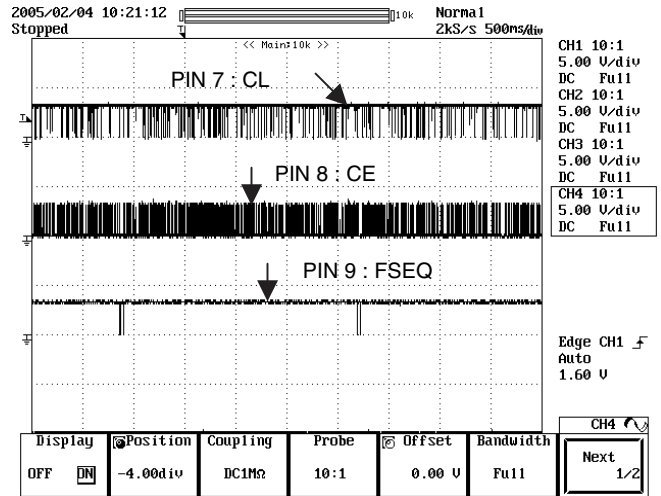

#2. SLED DRIVE AND MOTOR WAVEFORM
(IC802 PIN 5, 13) when focus search

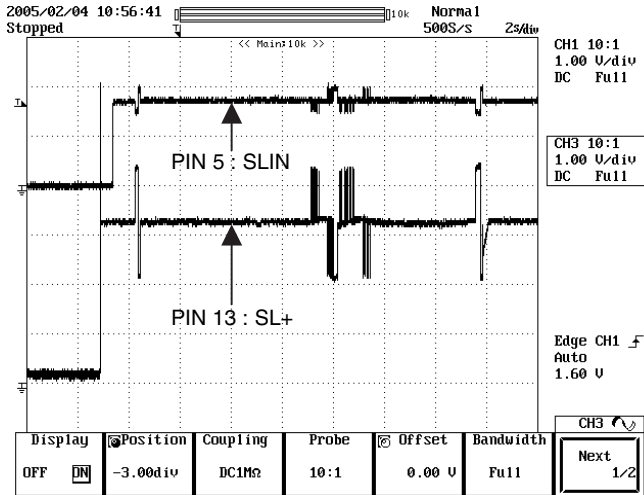

#2. SLED DRIVE AND MOTOR WAVEFORM
(IC802 PIN 5, 13) during normal play

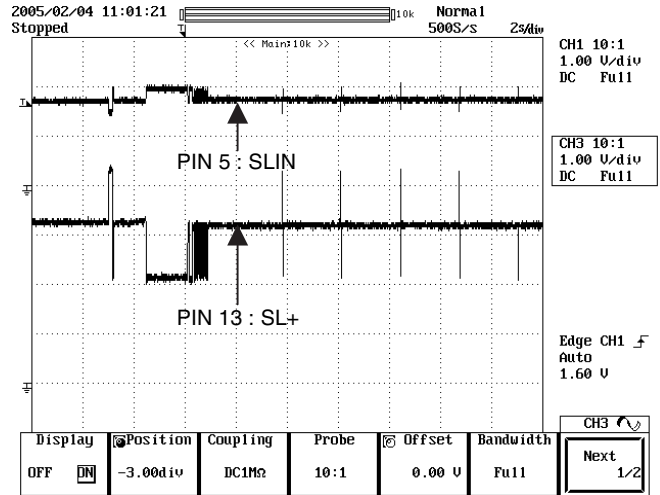

#3. FOCUS DRIVE AND MOTOR WAVEFORM
(IC802 PIN 25, IC802 PIN 16)

- When focus search failed or there is no disc on tray

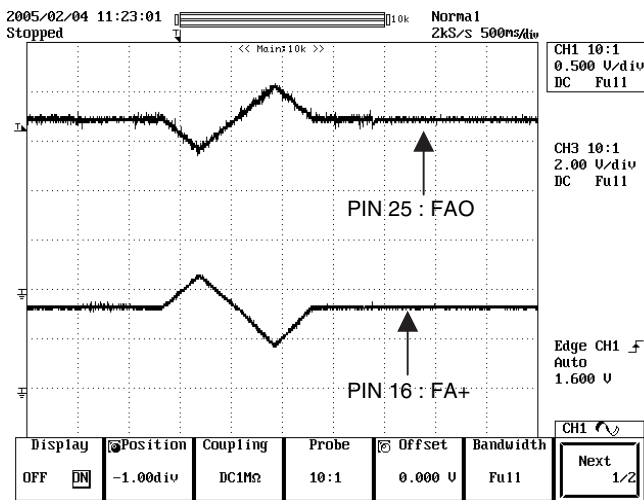

#3. FOCUS DRIVE AND MOTOR WAVEFORM
(IC802 PIN 25, IC802 PIN 16)

- There is disc on tray and focus search success

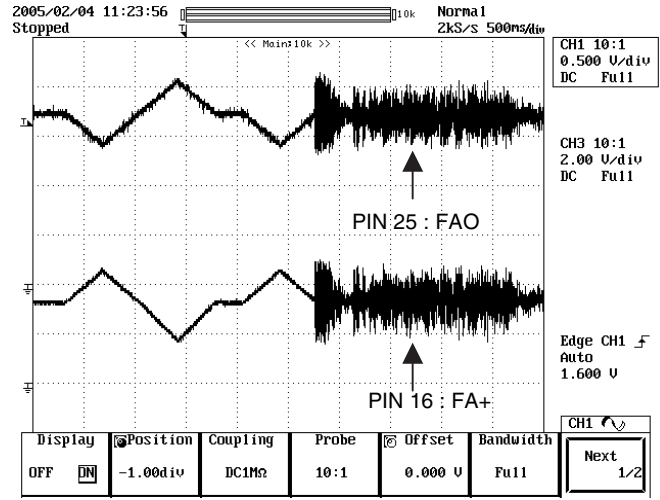

#4. SPINDLE DRIVE AND MOTOR WAVEFORM
(IC802 PIN 6, 11) when TOC reading

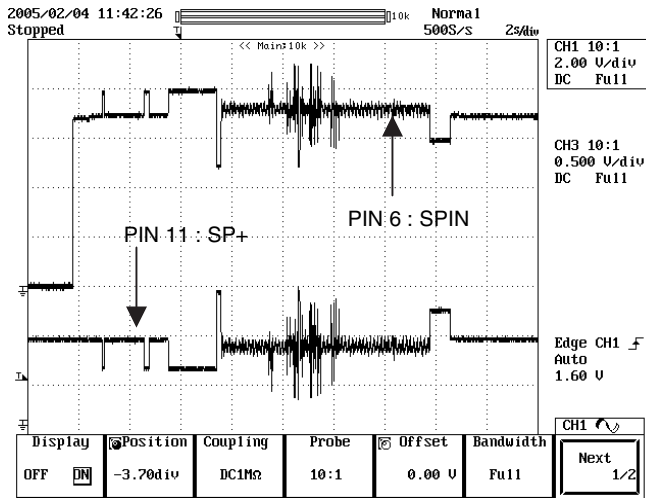

#5. TRACK DRIVE AND MOTOR WAVEFORM
(IC802 PIN 22, 17) during normal play

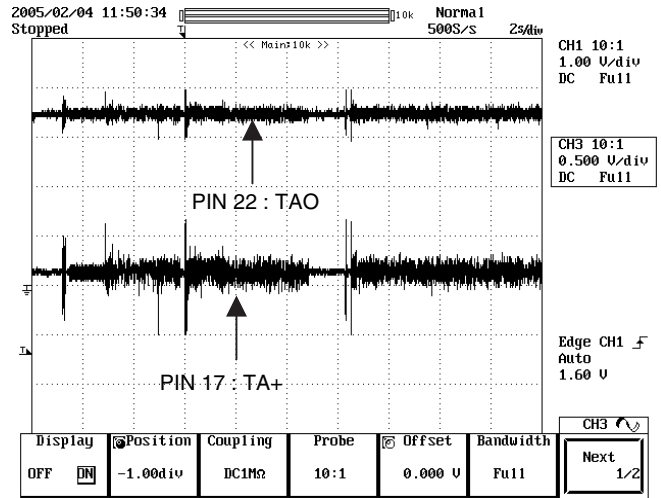

#6. RF, FOCUS AND TRACKING ERROR WAVEFORM
(IC801 PIN 2, 10, 16) during normal play

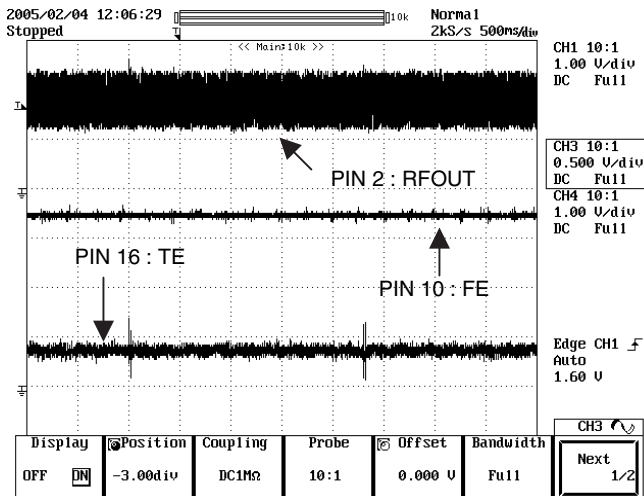

USB PART

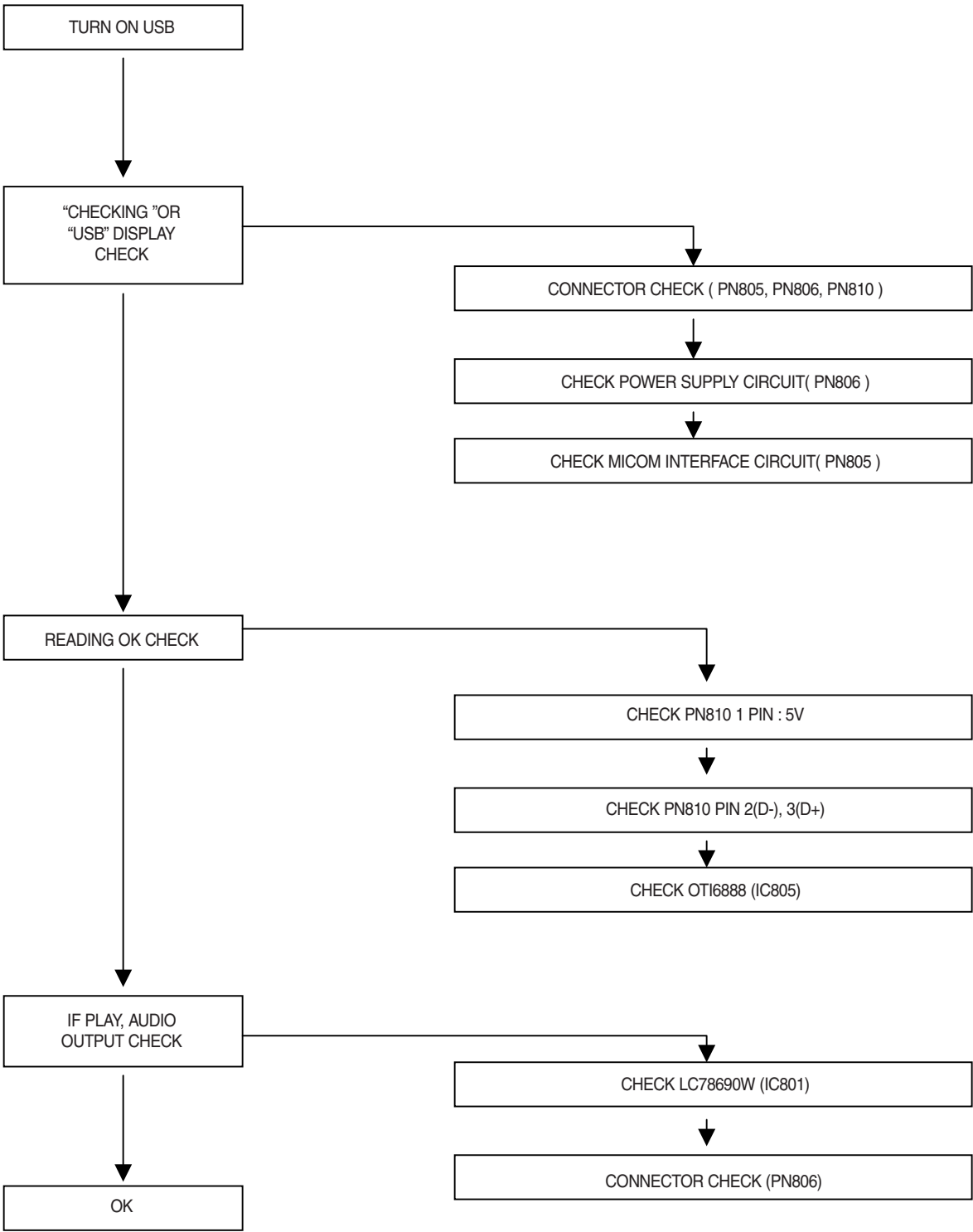

P-SENS CHECK

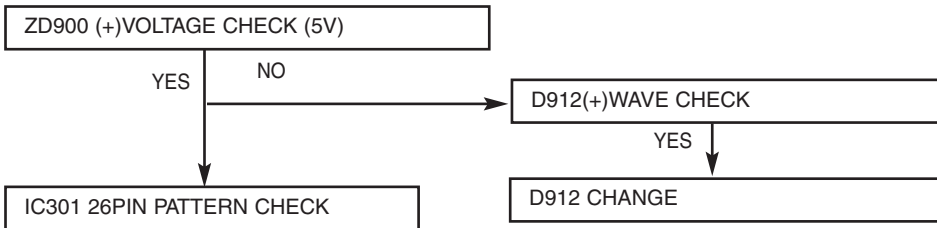

VKK CHECK

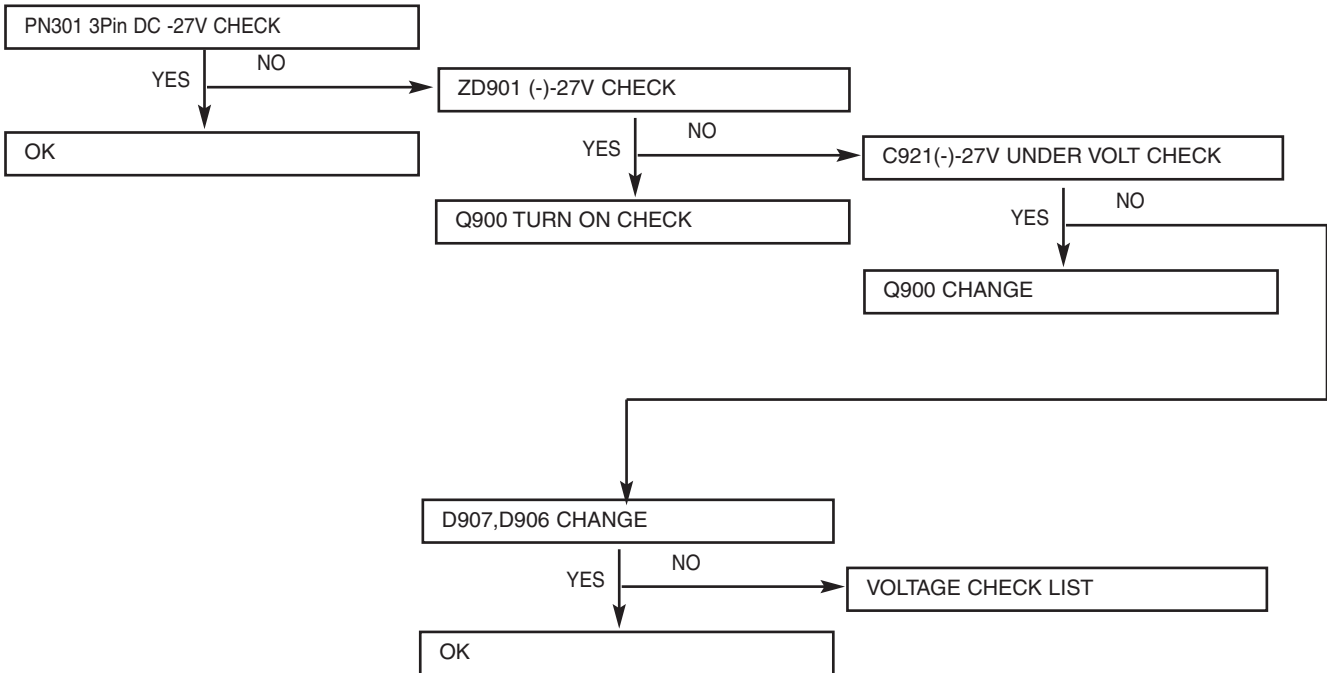

VOLTAGE CHECK

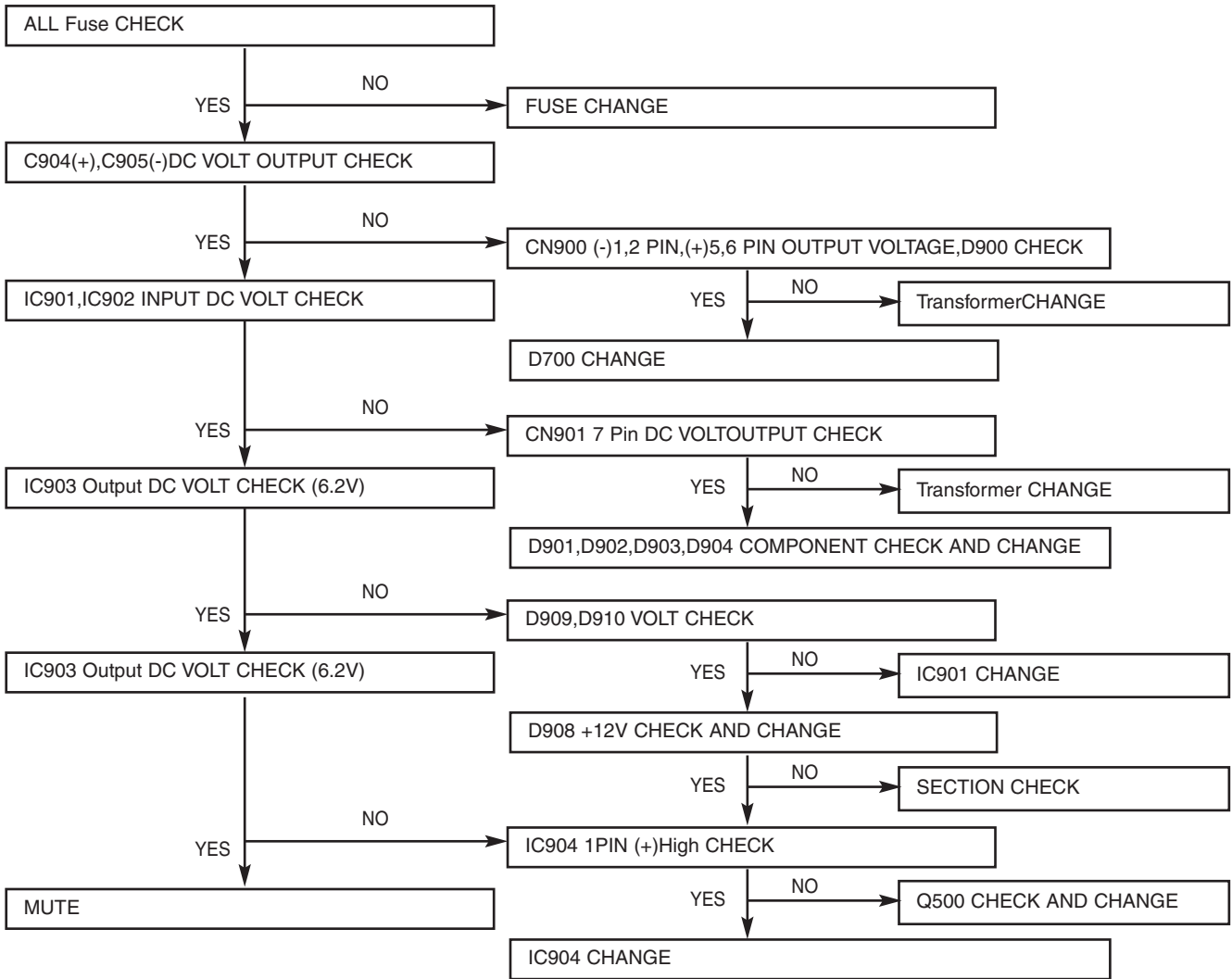

Muting CIRCUIT Troubleshooting (MUTE CONDITION)

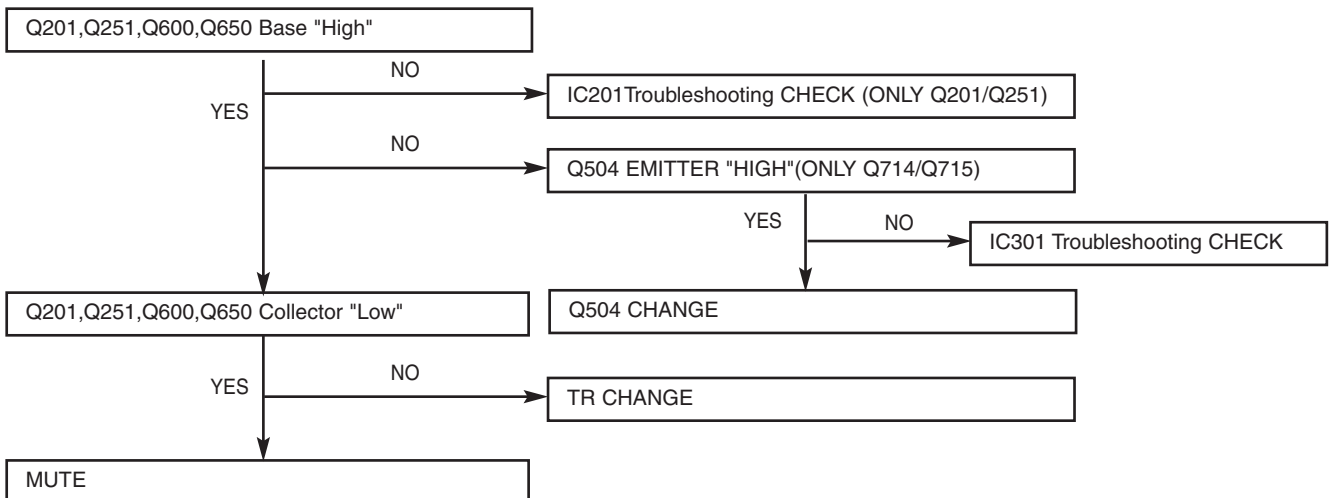

NO SOUND

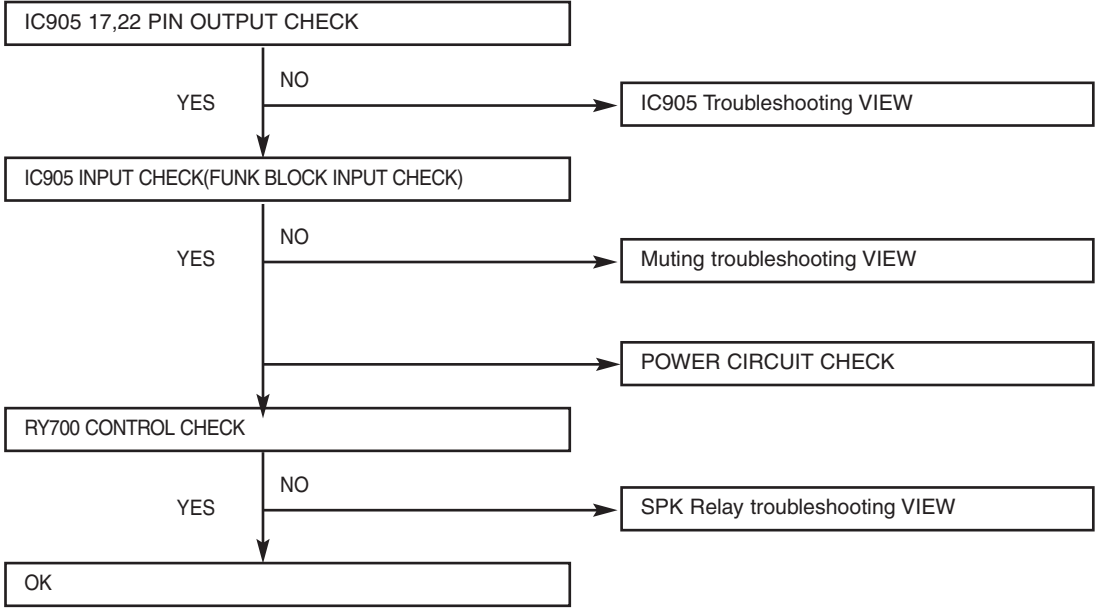

SPK Relay Troubleshooting (ONLY LX-W550` s)

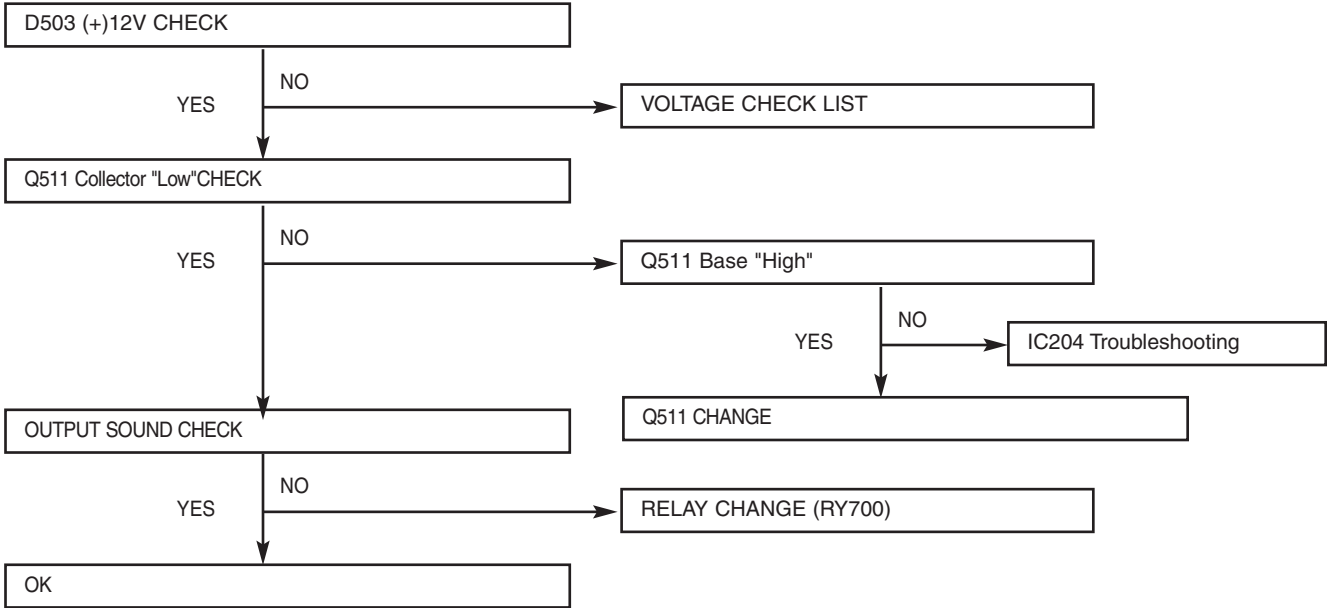

FUNCTION MODE (NO SOUND)

TAPE

YES

IC905 3,36PIN INPUT SIGNAL CHECK

YES

IC204 Troubleshooting

AUX

YES

IC905 5,34 PIN INPUT SIGNAL CHECK

YES

JK600 INPUT CHECK

CD

YES

IC905 4,35 PIN INPUT SIGNAL CHECK

YES

CD Troubleshooting

TUNER

YES

IC905 2,37 PIN INPUT SIGNAL CHECK

YES

IC102 Troubleshooting

DAB/L BAND/DAB+L

YES

IC905 6,33 PIN INPUT SIGNAL CHECK

YES

IC102 Troubleshooting

IC301 Troubleshooting

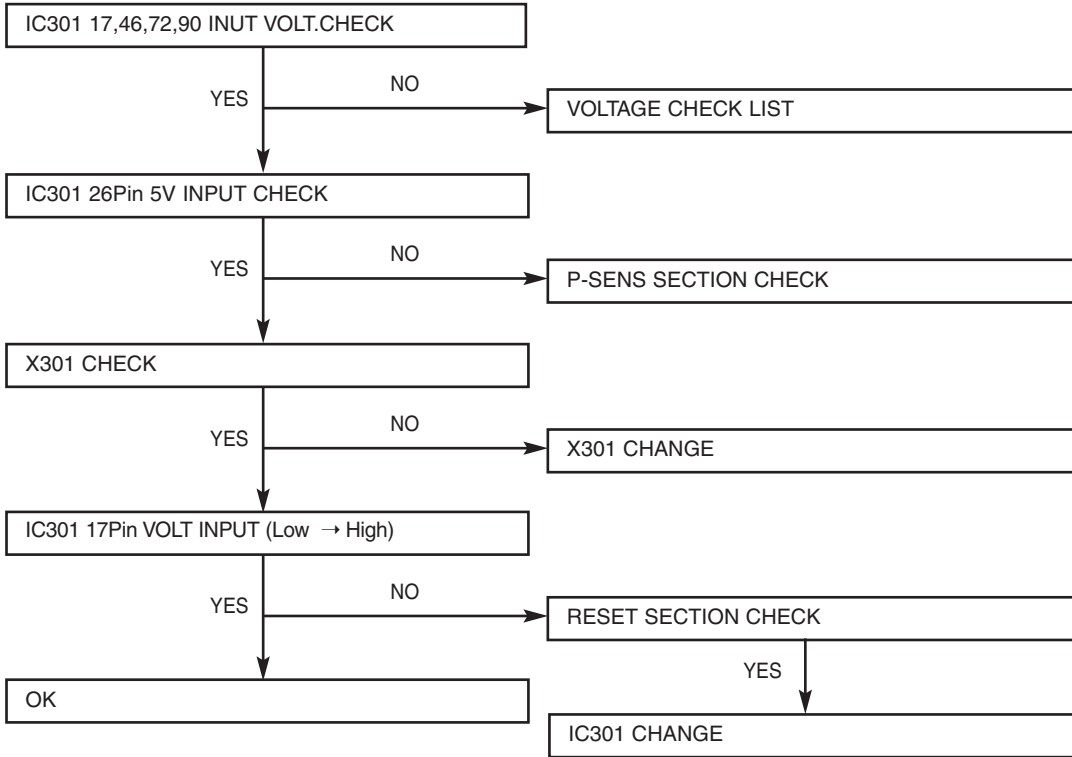

IC204 Troubleshooting

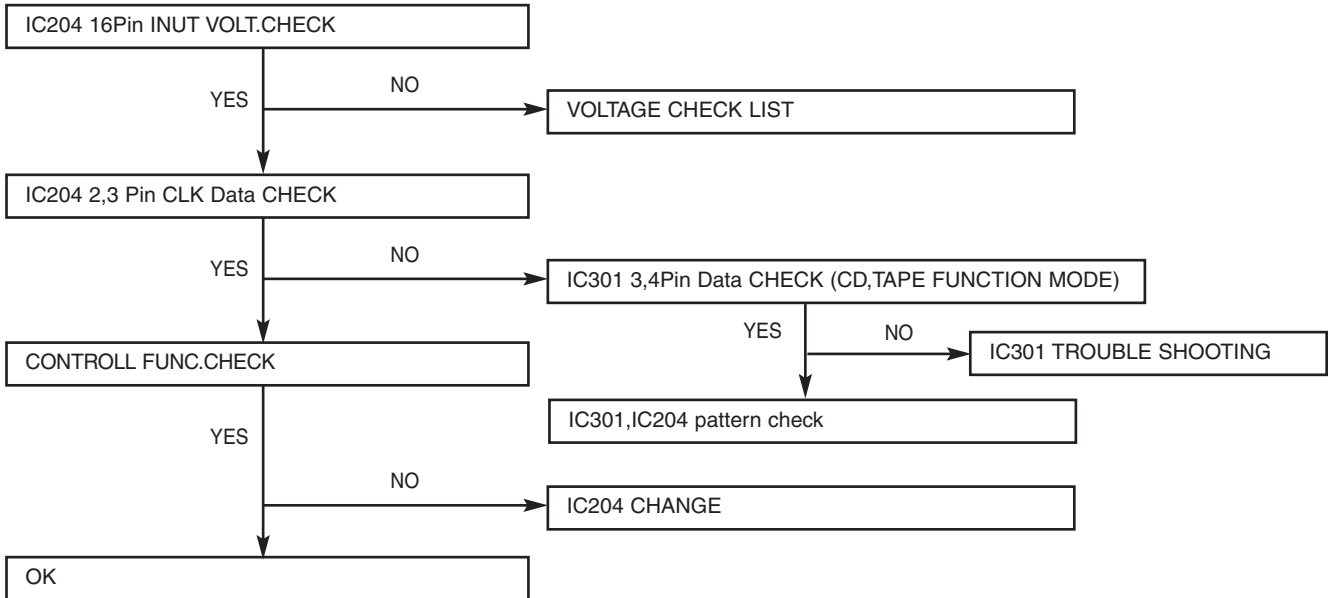

IC905 Troubleshooting

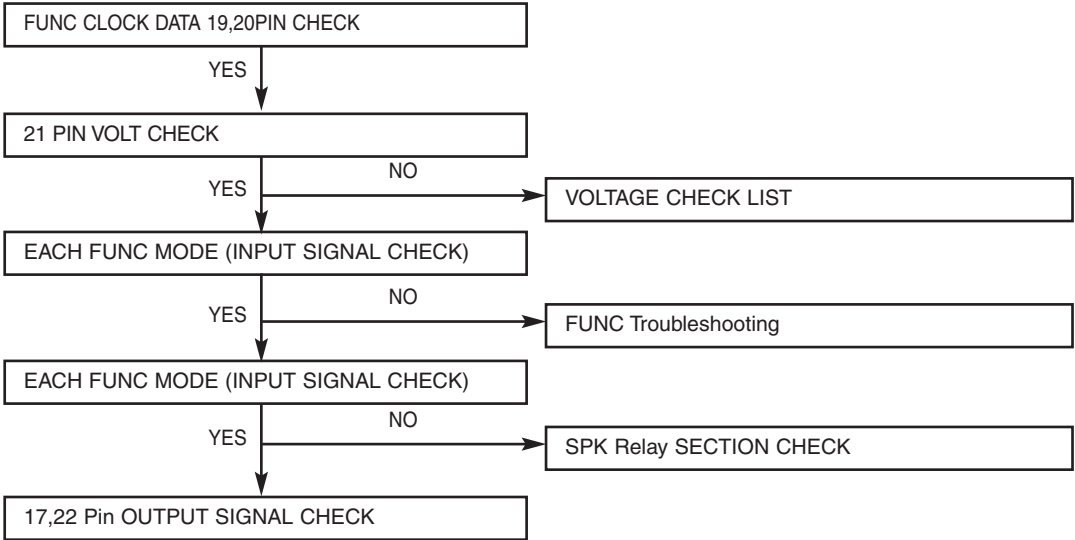

FM(TUN600)CHECK

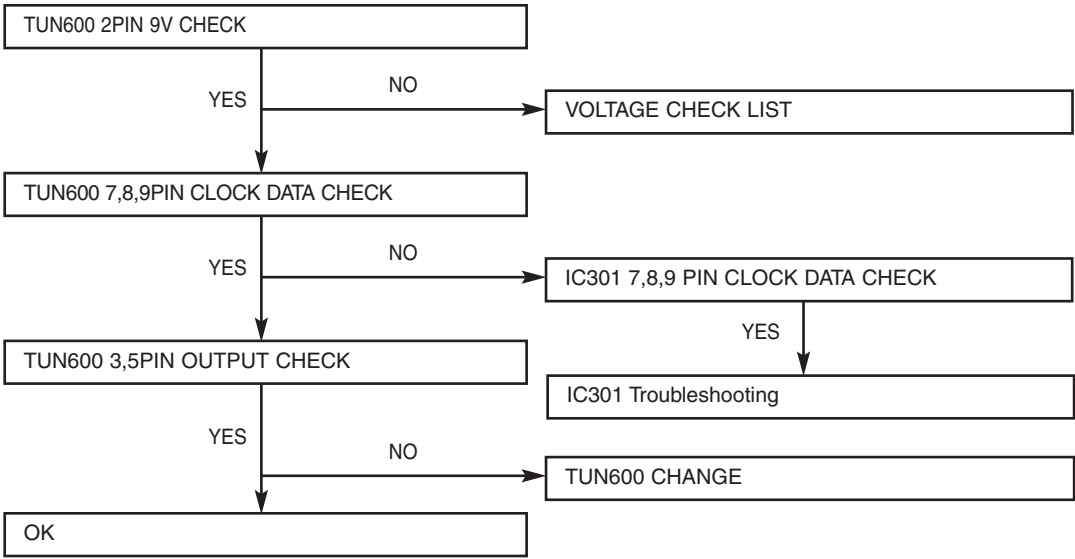

PLAY MODE CHECK

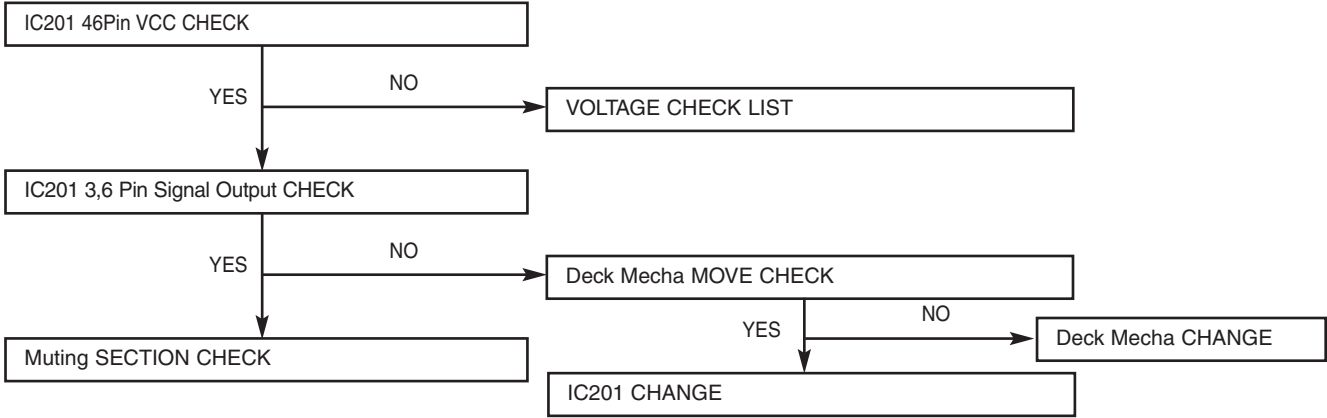

REC CHECK (Q202,Q252 ON:R220,270 HIGH)

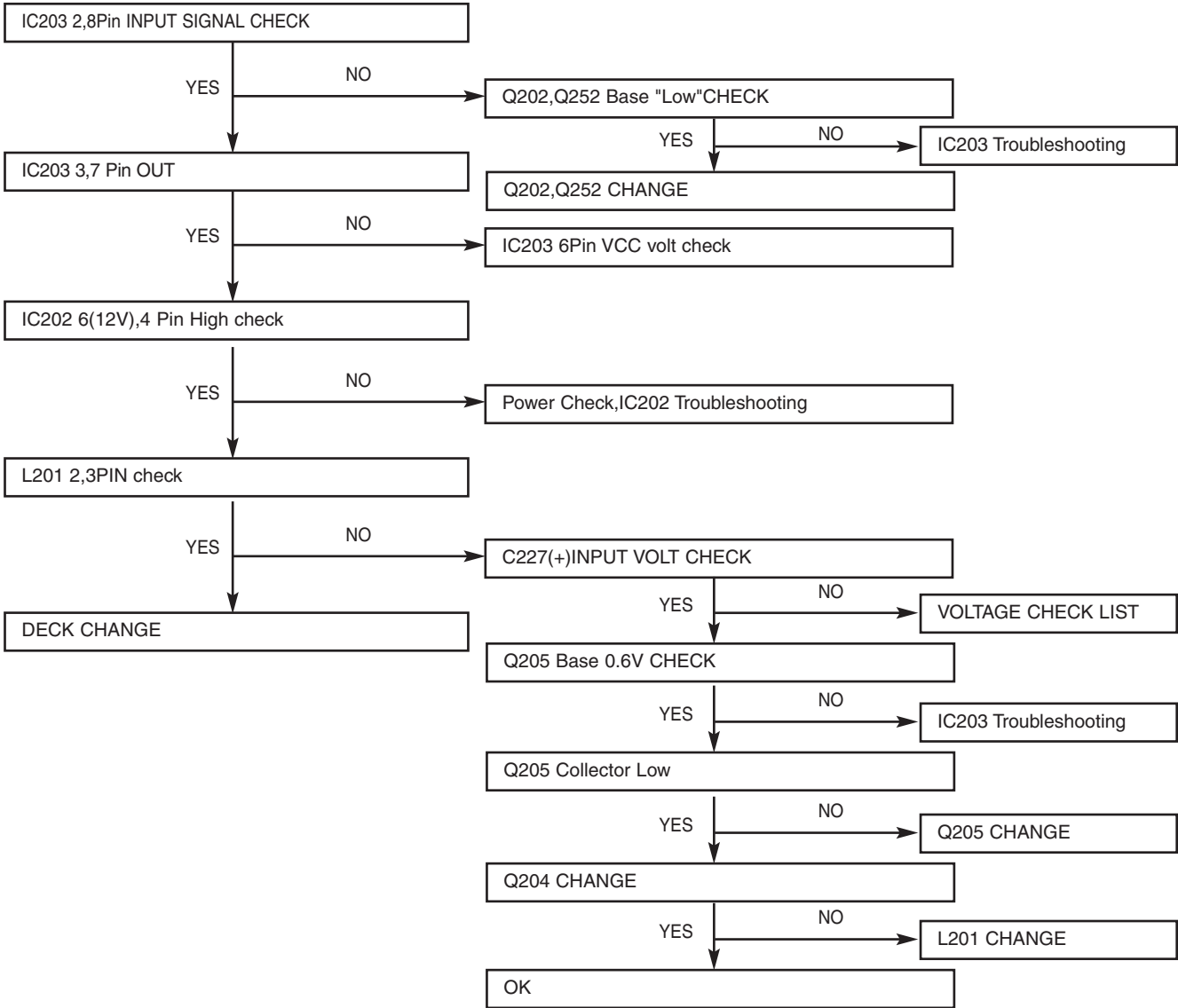

DAB/DAB+L /L BAND(DAB600,DAB600L)CHECK (ONLY DAB series MODEL)

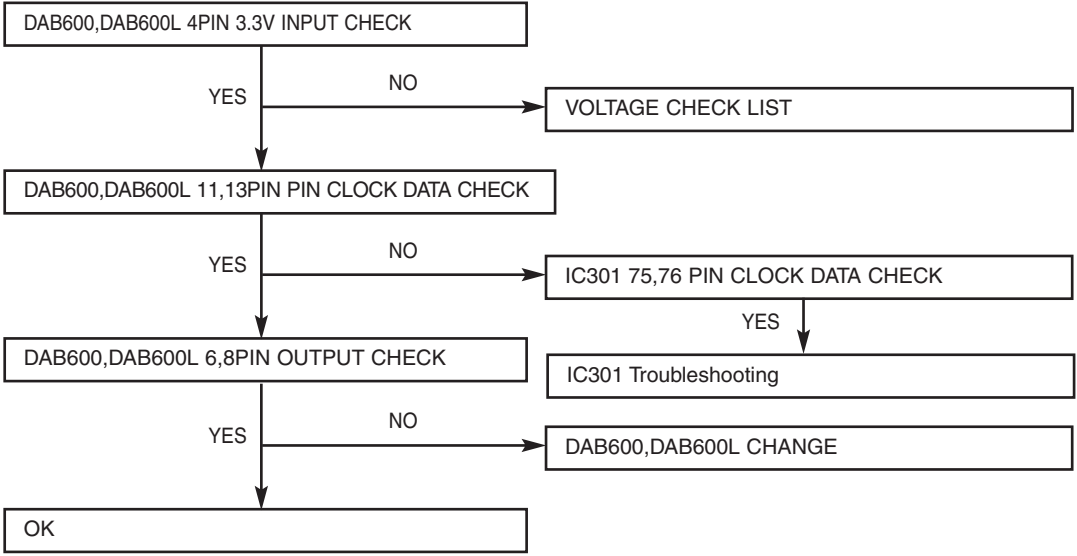

INTERNAL BLOCK DIAGRAM of ICs

• NJW1190 BLOCK DIAGRAM

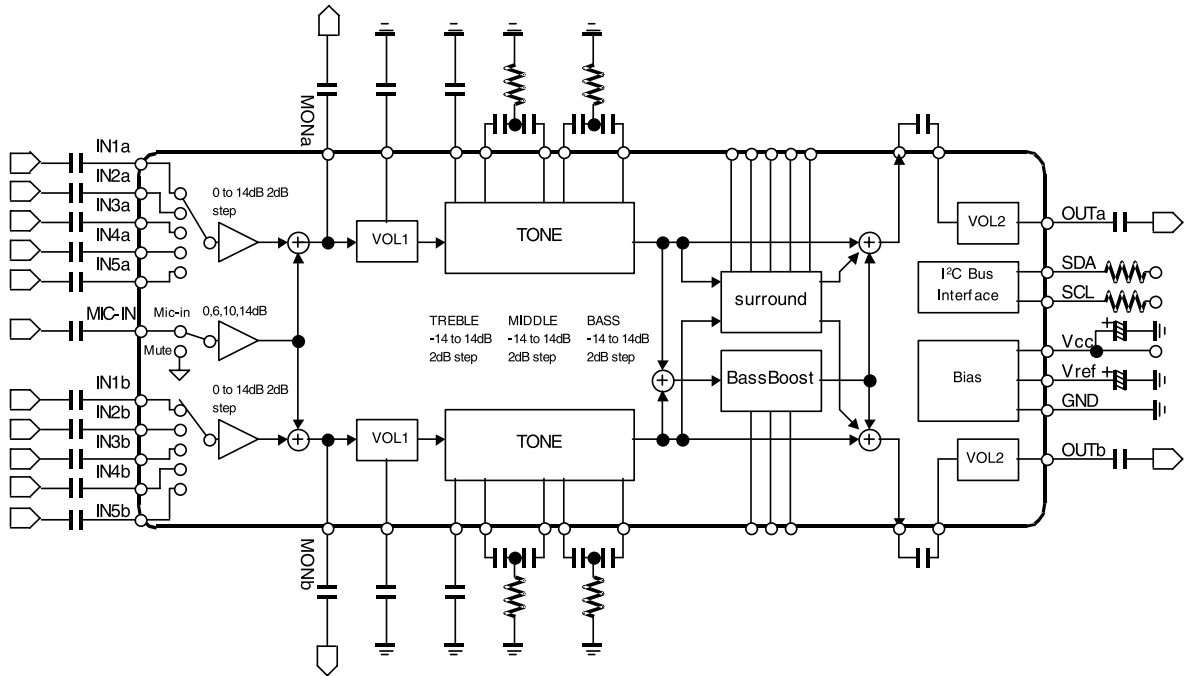

PIN FUNCTION (SSOP44)

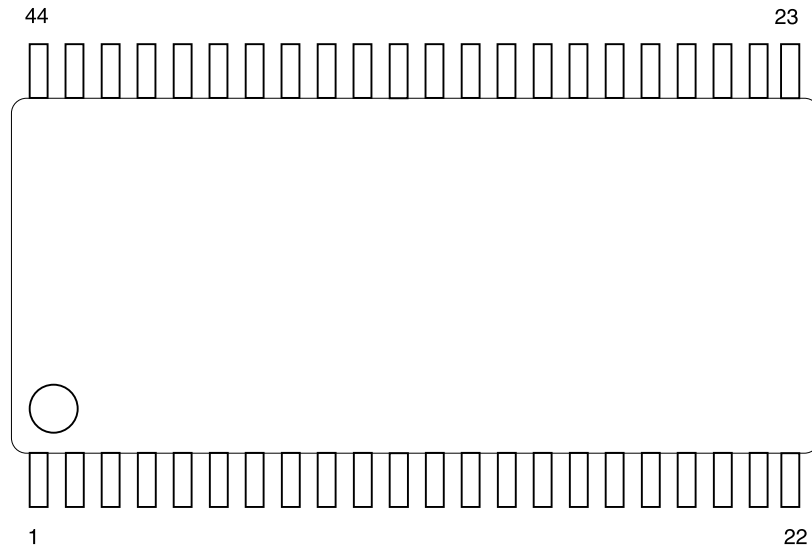

No.	SYMBOL	FUNCTION	No.	SYMBOL	FUNCT ION
1	M IC-IN	Microphone Input	23	SD A	SDA Data Input (I ² C BUS)
2	SR Fil1	Surround Filter1	24	V*	Power Supply Pin
3	SR Fil2	Surround Filter2	25	O UTb	Bch Output
4	VEFil1	Voice Enhancement Filter1	26	VOL2INb	Bch Volume2 Input
5	VEFil2	Voice Enhancement Filter2	27	SROUTb	Bch Surround Output
6	IN 1a	Ach Input1	28	TONE-L2b	Bch Bass Filter2
7	IN 2a	Ach Input2	29	TONE-L1b	Bch Bass Filter1
8	IN 3a	Ach Input3	30	TONE-M2b	Bch Middle Filter2
9	IN 4a	Ach Input4	31	TONE-M1b	Bch Middle Filter1
10	IN 5a	Ach Input5	32	TONE-Hb	Bch Treble Filter
11	MONOUTa	Ach Monitor Output	33	VOL1-DCb	Bch Volume1 Switching Noise Rejection Capacitor
12	VOL1-DCa	Ach Volume1 Switching Noise Rejection Capacitor	34	MONOUTb	Bch Monitor Output
13	TONE-Ha	Ach Treble Filter	35	IN5b	Bch Input5
14	TONE-M1a	Ach Middle Filter1	36	IN 4b	Bch Input4
15	TONE-M2a	Ach Middle Filter2	37	IN 3b	Bch Input3
16	TONE-L1a	Ach Bass Filter1	38	IN 2b	Bch Input2
17	TONE-L2a	Ach Bass Filter2	39	IN 1b	Bch Input1
18	SROUTa	Ach Surround Output	40	BBFil3	Bass Boost Filter3
19	VOL2INa	Ach Volume2 Input	41	BBFil2	Bass Boost Filter2
20	OUTa	Ach Output	42	BBFil1	Bass Boost Filter1
21	GND	GND	43	PSFil	Phase Shifter Filter
22	SCL	SCL Data Input (I ² C BUS)	44	Vref	Reference Voltage

PIN FUNCTION (QFP48-P1)

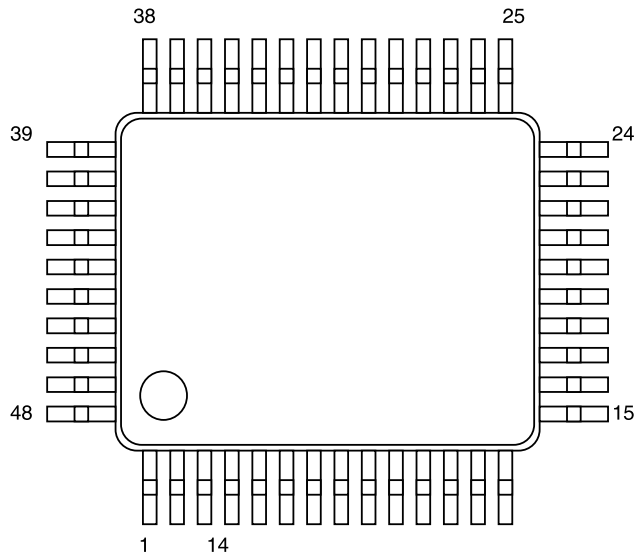

No.	SYMBOL	FUNCTION	No.	SYMBOL	FUNCTION
1	N.C.	No Connection	25	N.C.	No Connection
2	IN1a	Ach Input1	26	TONE-L2b	Bch Bass Filter2
3	IN2a	Ach Input2	27	TONE-L1b	Bch Bass Filter1
4	IN3a	Ach Input3	28	TONE-M2b	Bch Middle Filter2
5	IN4a	Ach Input4	29	TONE-M1b	Bch Middle Filter1
6	IN5a	Ach Input5	30	TONE-Hb	Bch Treble Filter
7	MONOUTa	Ach Monitor Output	31	VOL1-DCb	Bch Volume1 Switching Noise Rejection Capacitor
8	VOL1-DCa	Ach Volume1 Switching Noise Rejection Capacitor	32	MONOUTb	Bch Monitor Output
9	TONE-Ha	Ach Treble Filter	33	IN5b	Bch Input5
10	TONE-M1a	Ach Middle Filter1	34	IN4b	Bch Input4
11	TONE-M2a	Ach Middle Filter2	35	IN3b	Bch Input3
12	TONE-L1a	Ach Bass Filter1	36	IN2b	Bch Input2
13	TONE-L2a	Ach Bass Filter2	37	IN1b	Bch Input1
14	N.C.	No Connection	38	N.C.	No Connection
15	SROUTa	Ach Surround Output	39	BBFi3	Bass Boost Filter3
16	VOL2INa	Ach Volume2 Input	40	BBFi2	Bass Boost Filter2
17	OUTa	Ach Output	41	BBFi1	Bass Boost Filter1
18	GND	GND	42	PSFi1	Phase Shifter Filter
19	SCL	SCL Data Input (I ² C BUS)	43	Vref	Reference Voltage
20	SDA	SDA Data Input (I ² C BUS)	44	MIC-IN	Microphone Input
21	V ⁺	Power Supply Pin	45	SRFi1	Surround Filter1
22	OUTb	Bch Output	46	SRFi2	Surround Filter2
23	VOL2INb	Bch Volume2 Input	47	VEFi1	Voice Enhancement Filter1
24	SROUTb	Bch Surround Output	48	VEFi2	Voice Enhancement Filter2

• IC805
BLOCK DIAGRAM

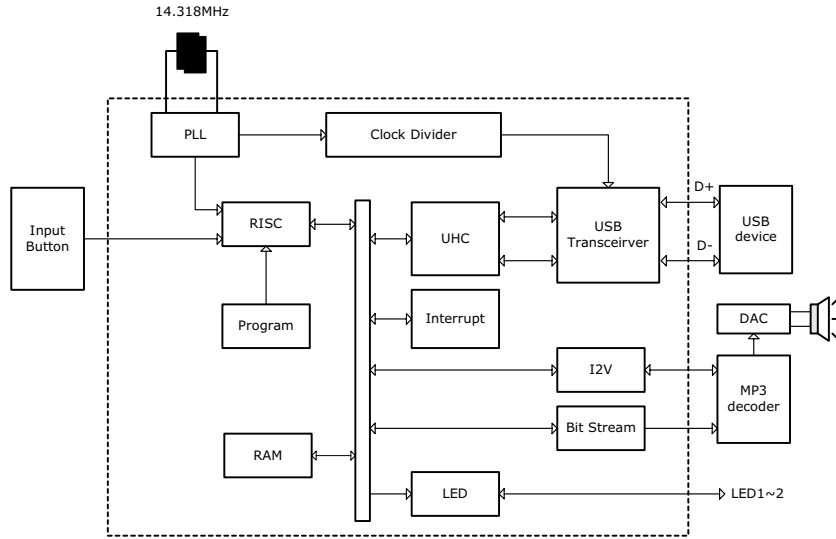

• PIN CONFIGURATION

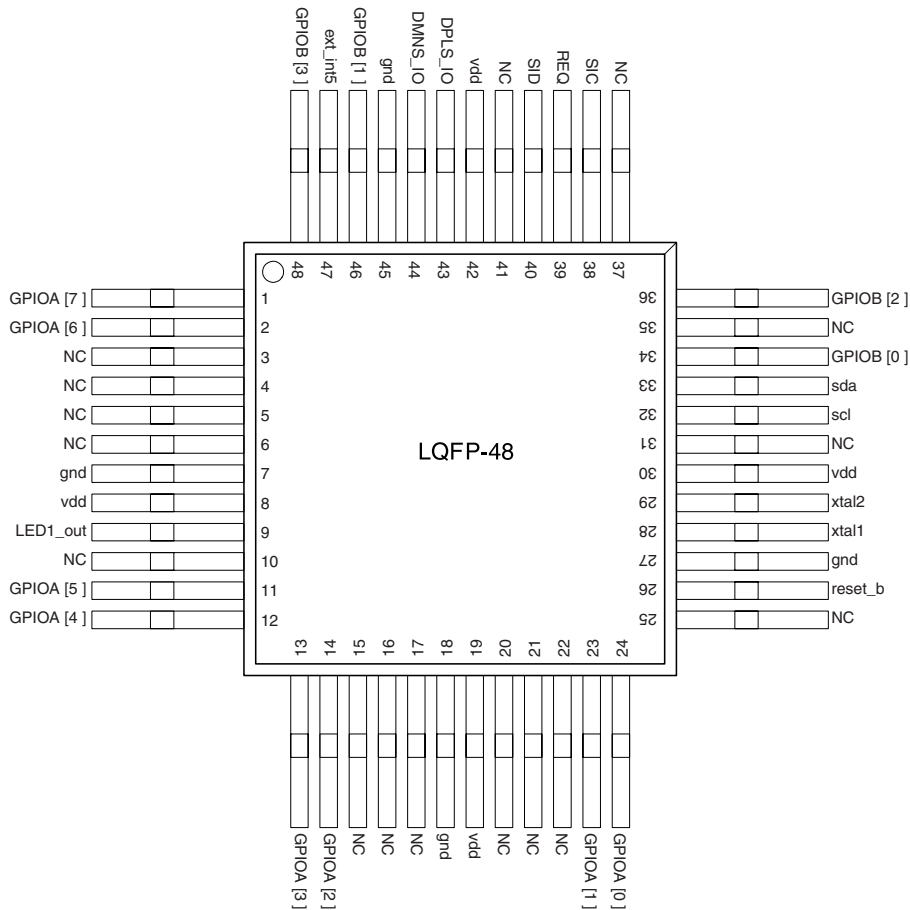

PIN CONFIGURATION

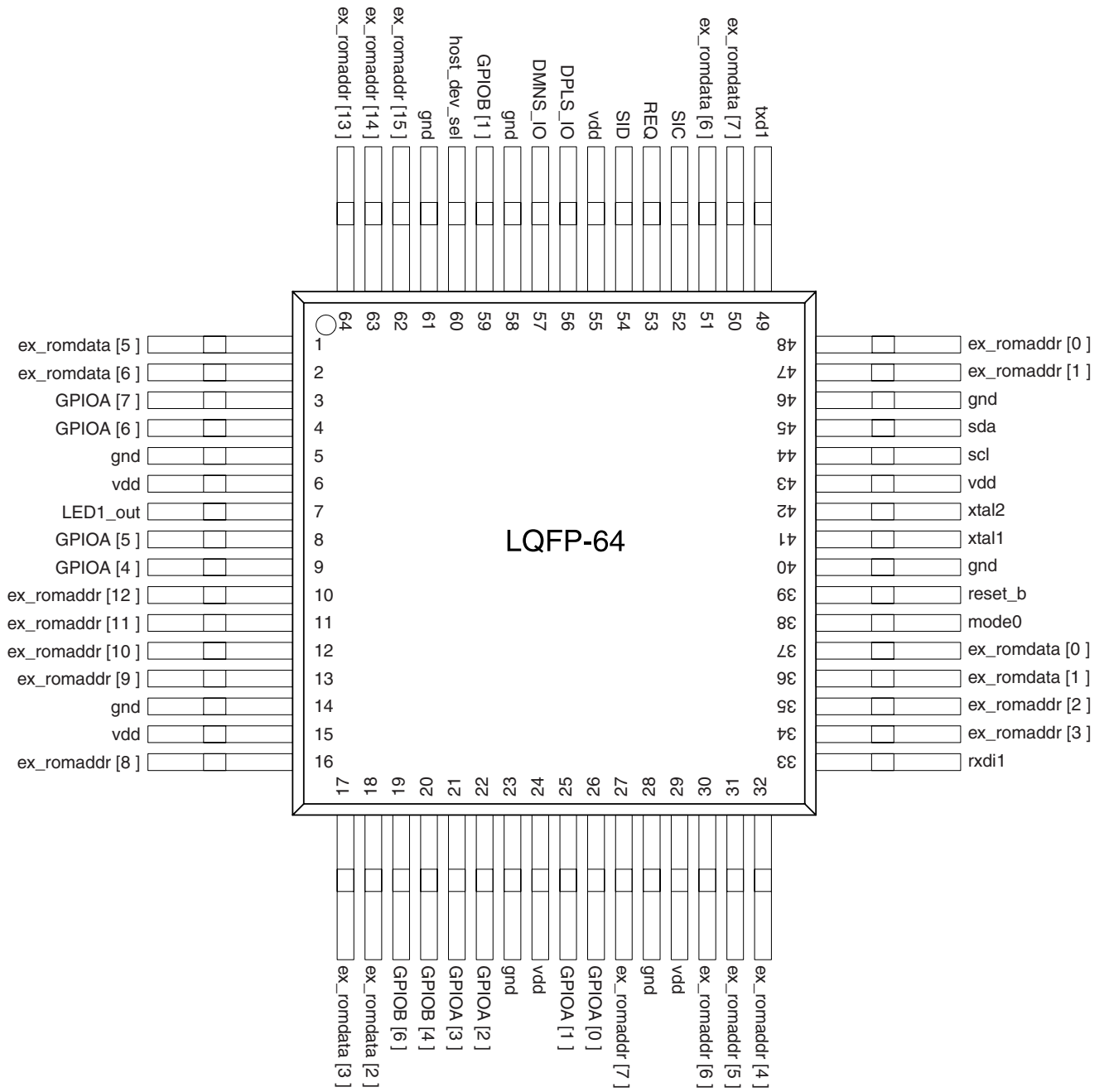

• **AM5810 (IC802)**
BLOCK DIAGRAM

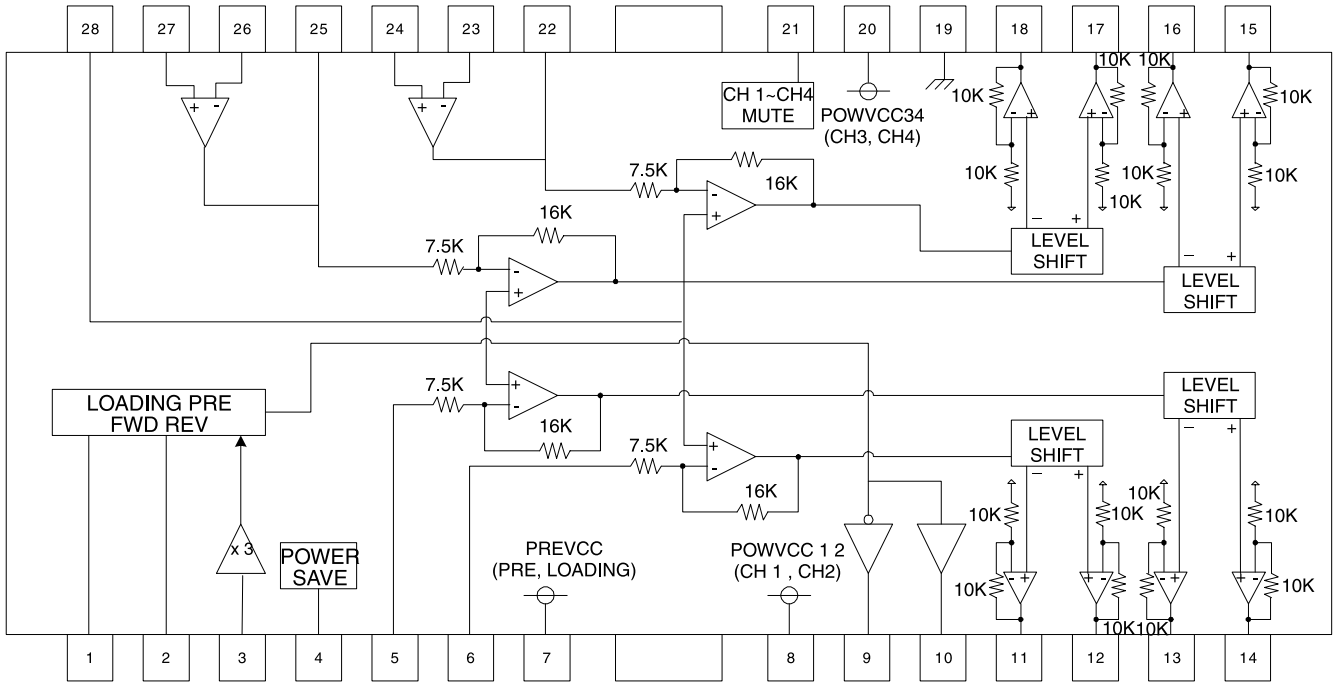

PIN CONFIGURATION

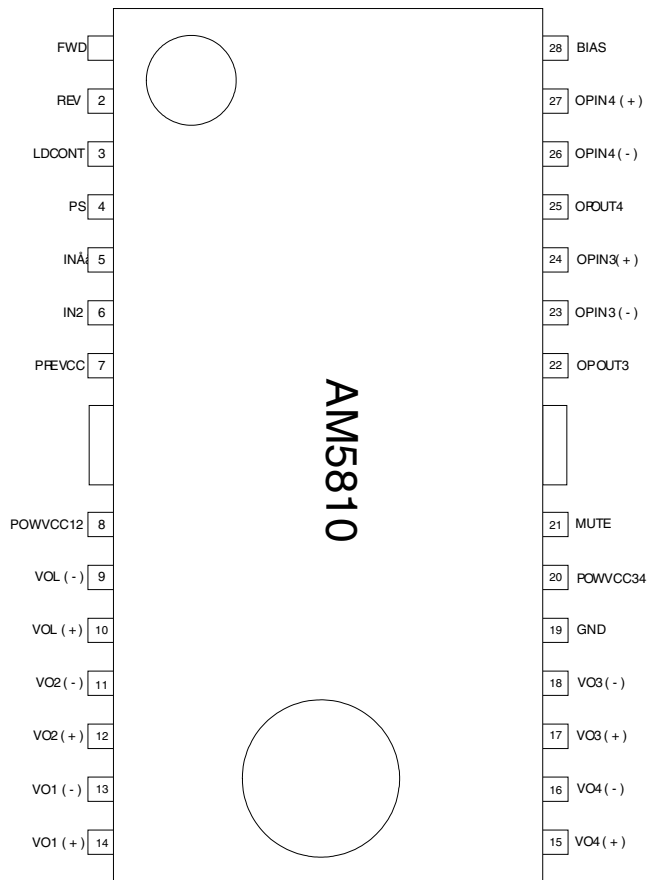

PIN DESCRIPTION

PIN No	Pin Name	Description
1	FWD	Input for loading forward
2	REV	Input for loading reverse
3	LDCONT	Output control terminal for loading
4	PS	Control terminal for power saving mode
5	IN1	Input 1 of CH1
6	IN2	Input 2 of CH2
7	PREVCC	Pre and loading unit power supply input terminal
8	POWVCC12	Power unit power supply input terminal (CH1, CH2)
9	VOL (-)	Inverted output of loading
10	VOL (+)	Not inverted output of loading
11	VO2 (-)	Inverted output of CH2
12	VO2 (+)	Not inverted output of CH2
13	VO1 (-)	Inverted output of CH1
14	VO1 (+)	Not inverted output of CH1
15	VO4 (+)	Not inverted output of CH4
16	VO4 (-)	Inverted output of CH4
17	VO3 (+)	Not inverted output of CH3
18	VO3 (-)	Inverted output of CH3
19	GND	Substrate ground
20	POWVCC34	Power unit power supply input terminal (CH3, CH4)
21	MUTE	Input for mute control
22	OPOUT3	Output of CH3 OP-AMP
23	OPIN3 (-)	Inverting input of CH3 OP-AMP
24	OPIN3 (+)	Not inverting input of CH3 OP-AMP
25	OPOUT4	Output of CH4 OP-AMP
26	OPIN4 (-)	Inverting input of CH4 OP-AMP
27	OPIN4 (+)	Not inverting input of CH4 OP-AMP
28	BIAS	Input for reference voltage

□ BLOCK DIAGRAM

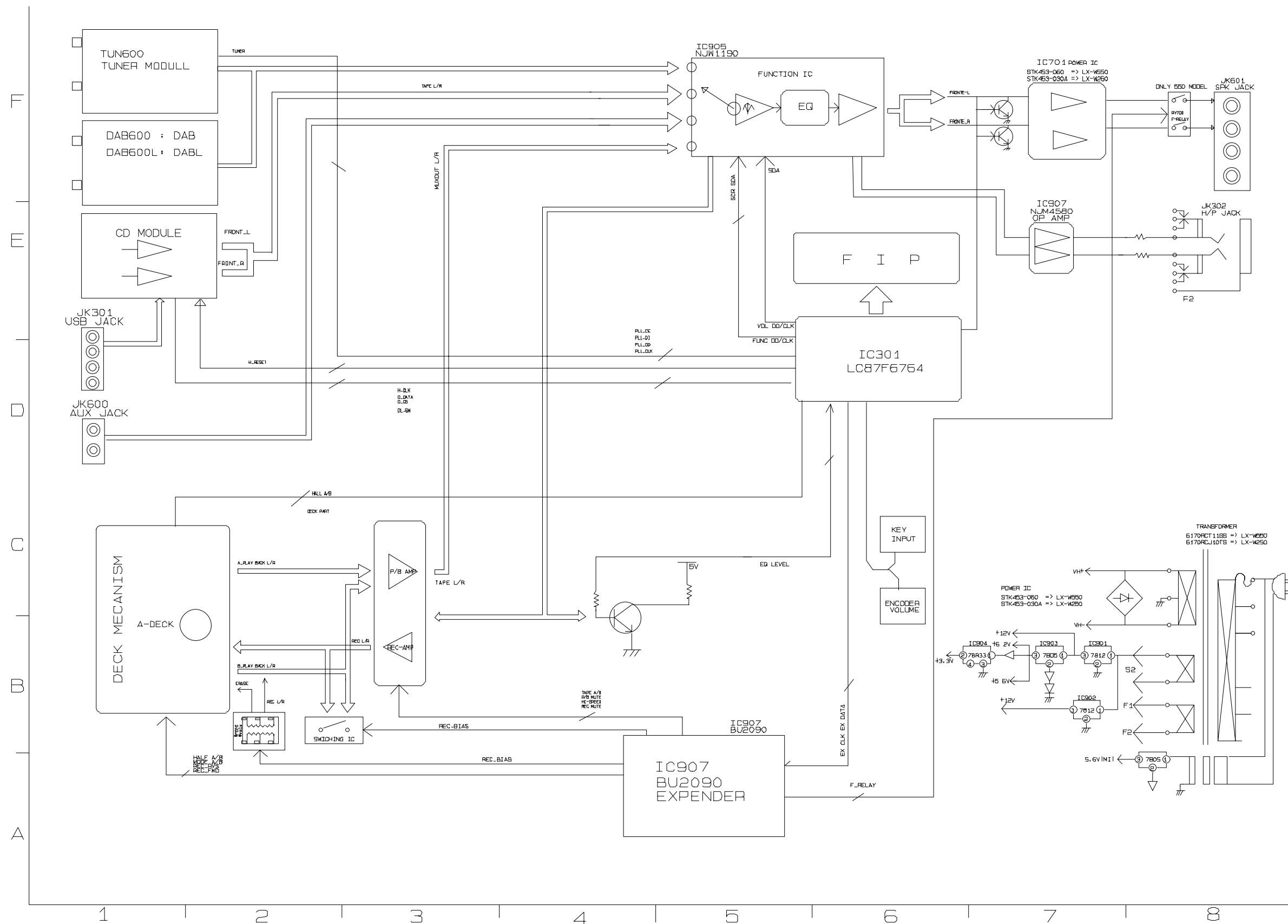

• WMA/USB BLOCK DIAGRAM

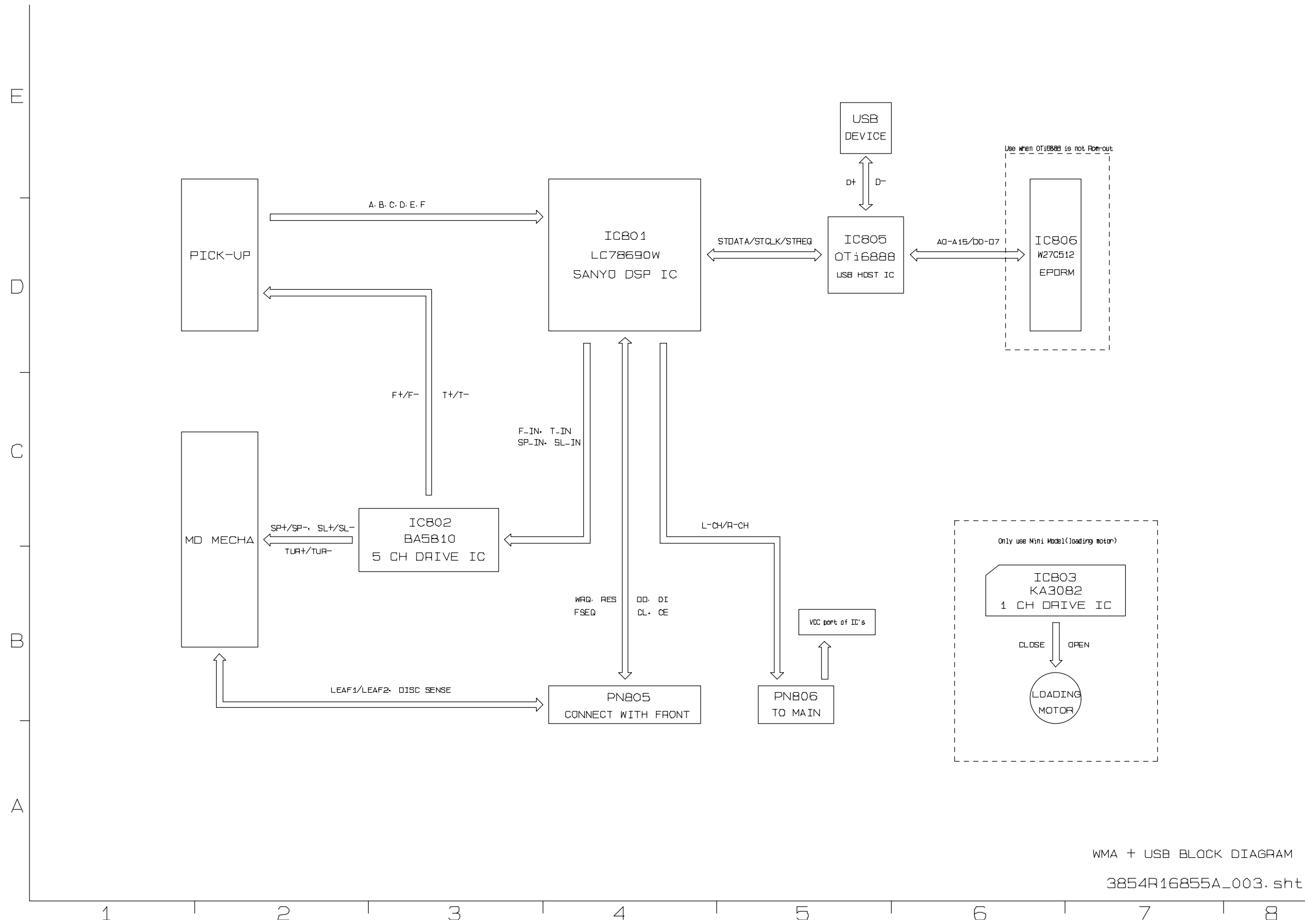

SCHEMATIC DIAGRAMS

MAIN SCHEMATIC DIAGRAM

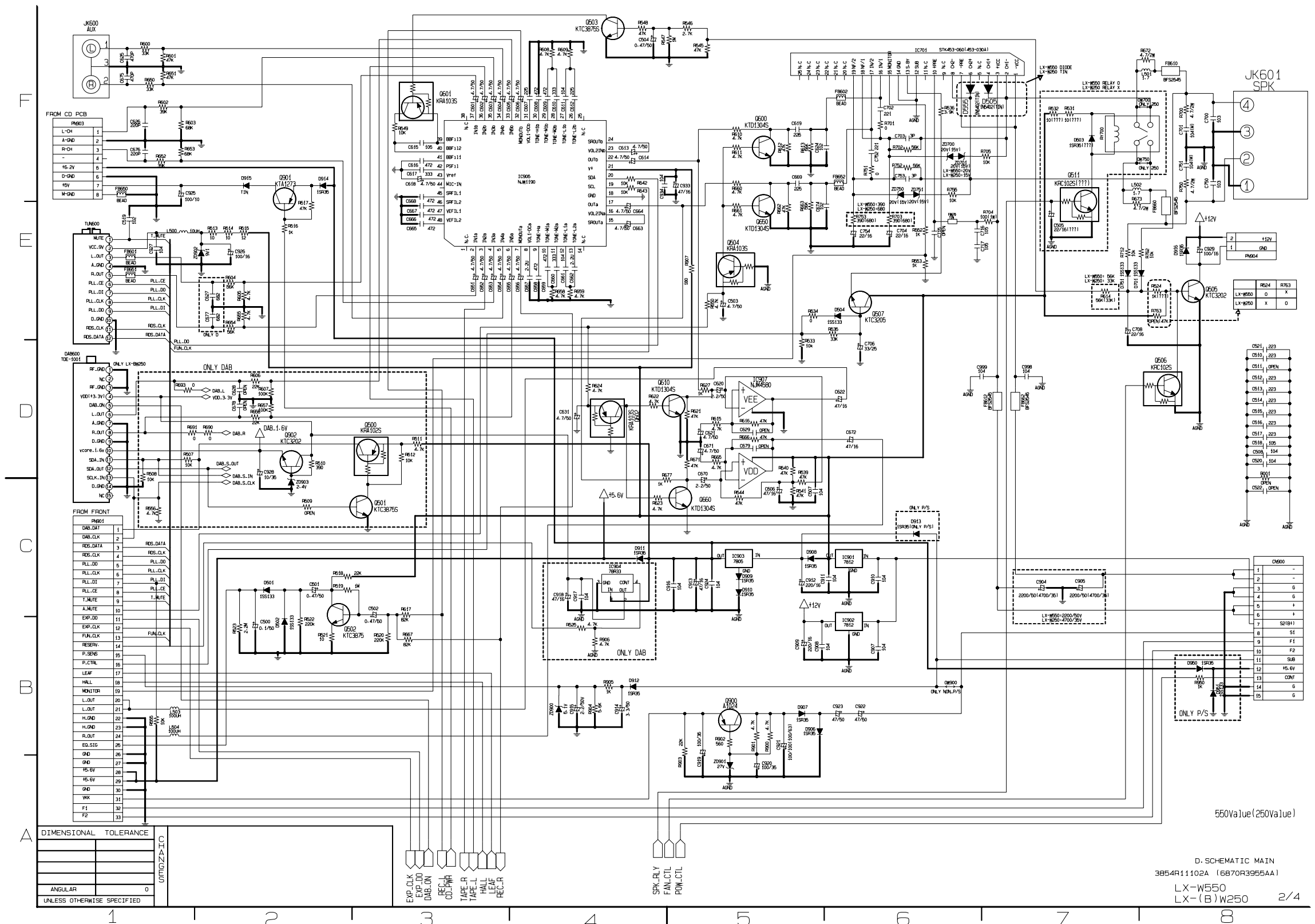

FRONT SCHEMATIC DIAGRAM

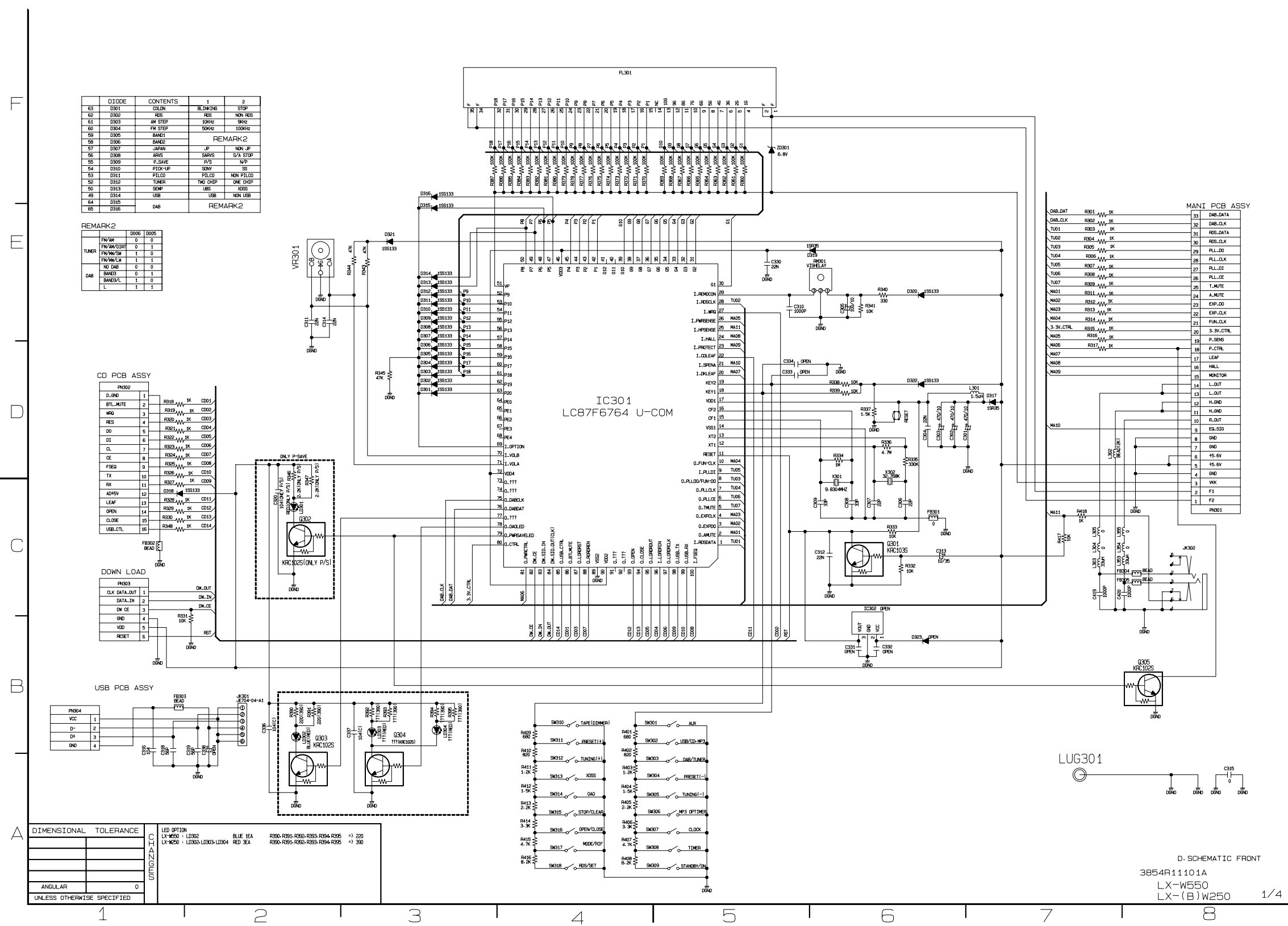

DIODE	CONTENTS	1	2
63	D301	COLDN	BLINKING STOP
62	D302	RES	RES NON RES
61	D303	AM STEP	50KHZ 90KZ
60	D304	FM STEP	50KHZ 100KHZ
59	D305	BANK1	
58	D306	BANK2	REMARK2
57	D307	JAPAN	NON JP
56	D308	ARKS	BARKS S/A STOP
55	D309	P-SAVE	V/S V/S
54	D310	PICK-UP	SONY SS
53	D311	PILCO	NON PILCO
52	D312	TUNER	TAC CHIP ONE CHIP
50	D313	SWP	RES
49	D314	USB	NON USB
64	D315	DAB	REMARK2
65	D316		

REMARK2

	D006	D005
FM/AM	0	0
FM/AM/DM	0	1
FM/AM/DM	1	0
FM/AM/LM	1	1
NO DAB	0	0
BANK1	0	1
BANK2/L	1	0
L	1	1

CD PCB ASSY

PN302			
D_IN0	1	R318	1K CD01
BTL_MUTE	2	R319	1K CD02
MPG	3	R320	1K CD03
RES	4	R321	1K CD04
DI	5	R322	1K CD05
CL	6	R323	1K CD06
CE	7	R324	1K CD07
FSED	8	R325	1K CD08
TX	9	R326	1K CD10
EX	11	R327	1K CD09
ADHSV	12	R328	1K CD11
LEAF	13	R329	1K CD12
OPEN	14	R330	1K CD13
CLOSE	15	R331	1K CD14
USB_CTL	16	R332	1K CD14

DOWN LOAD

PN303			
CLK_DATA_OUT	1	DM_OUT	DM_IN
DATA_IN	2	DM_CE	
DM_CE	3		
GND	4		
VDD	5		
RESET	6		

USB PCB ASSY

PN304			
VCC	1		
D-	2		
D+	3		
GND	4		

DIMENSIONAL TOLERANCE

UNIT	VALUE
ANGULAR	0

UNLESS OTHERWISE SPECIFIED

LED OPTION

LED	OPTION
LX-W550	L3302
LX-W250	L3303-L3304

BLUE SEA R300-R394 R392-R393 R394 R395 => 220
RED SEA R300-R394 R392-R393 R394 R395 => 390

MANI PCB ASSY

MANI	MANI	MANI	MANI
DAB_DAT	R301	1K	33 DAB_DATA
DAB_CLK	R302	1K	32 DAB_CLK
TU01	R303	1K	31 RES_DATA
TU02	R304	1K	30 RES_CLK
TU03	R305	1K	29 PLL_DD
TU04	R306	1K	28 PLL_OI
TU05	R307	1K	27 PLL_OI
TU06	R308	1K	26 PLL_CE
TU07	R309	1K	25 T_MUTE
MA01	R310	1K	24 A_MUTE
MA02	R311	1K	23 EXP_DD
MA03	R312	1K	22 EXP_CLK
MA04	R313	1K	21 FUN_CLK
3-3V_CTRL	R314	1K	20 3-3V_CTRL
MA05	R315	1K	19 P_SENS
MA06	R316	1K	18 P_CTRL
MA07	R317	1K	17 LEAF
MA08			16 HALL
MA09			15 MONITOR
			14 L_OUT
			13 H_OUT
			12 H_SND
			11 R_OUT
			10 EQ_S10
			9 GND
			8 GND
			7 GND
			6 15.6V
			5 15.6V
			4 GND
			3 WK
			2 P1
			1 P2

D. SCHEMATIC FRONT
3854R11101A
LX-W550
LX-(B)W250 1/4

WIRING DIAGRAM

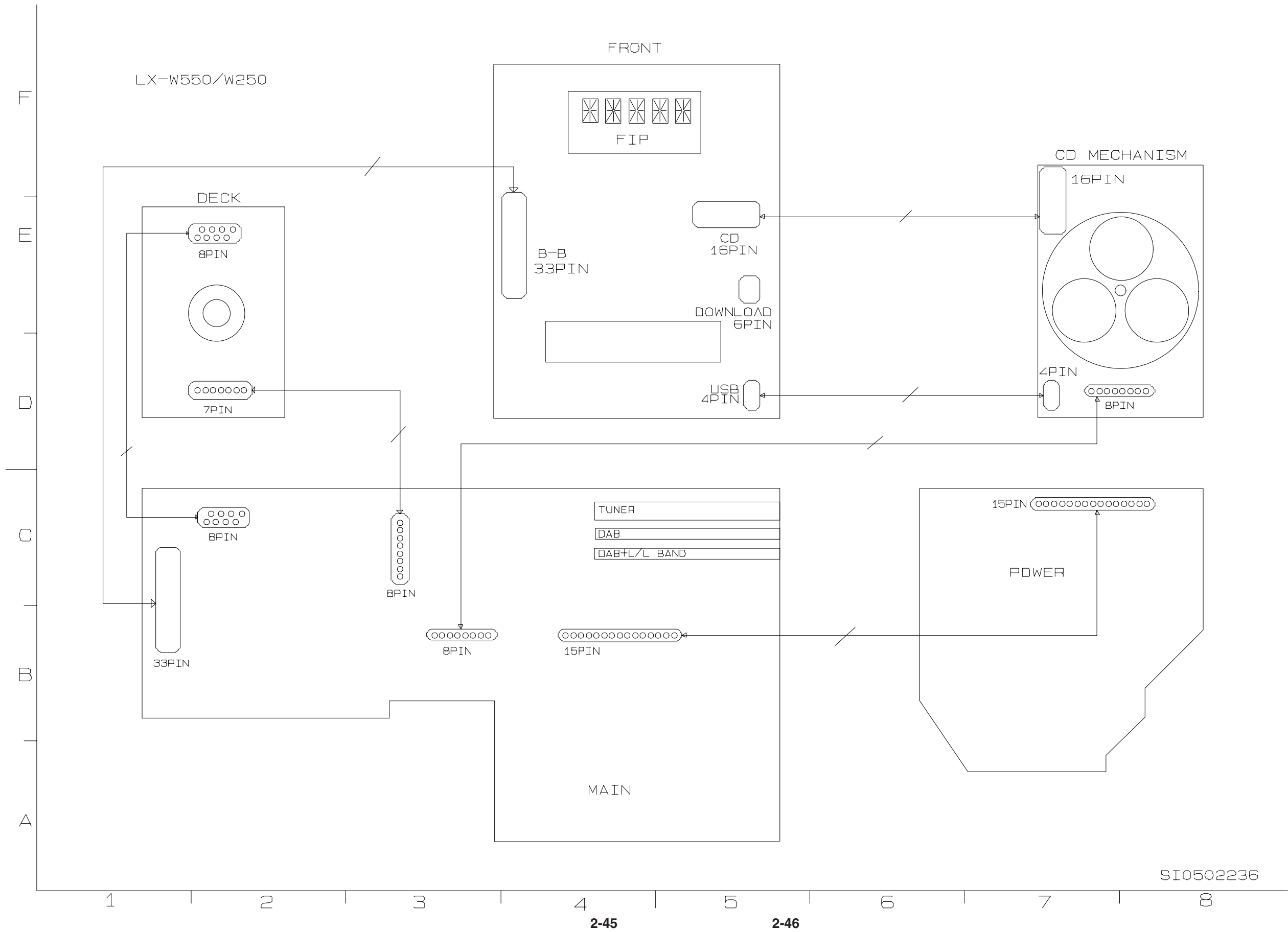

PRINTED CIRCUIT DIAGRAMS

MAIN P.C. BOARD

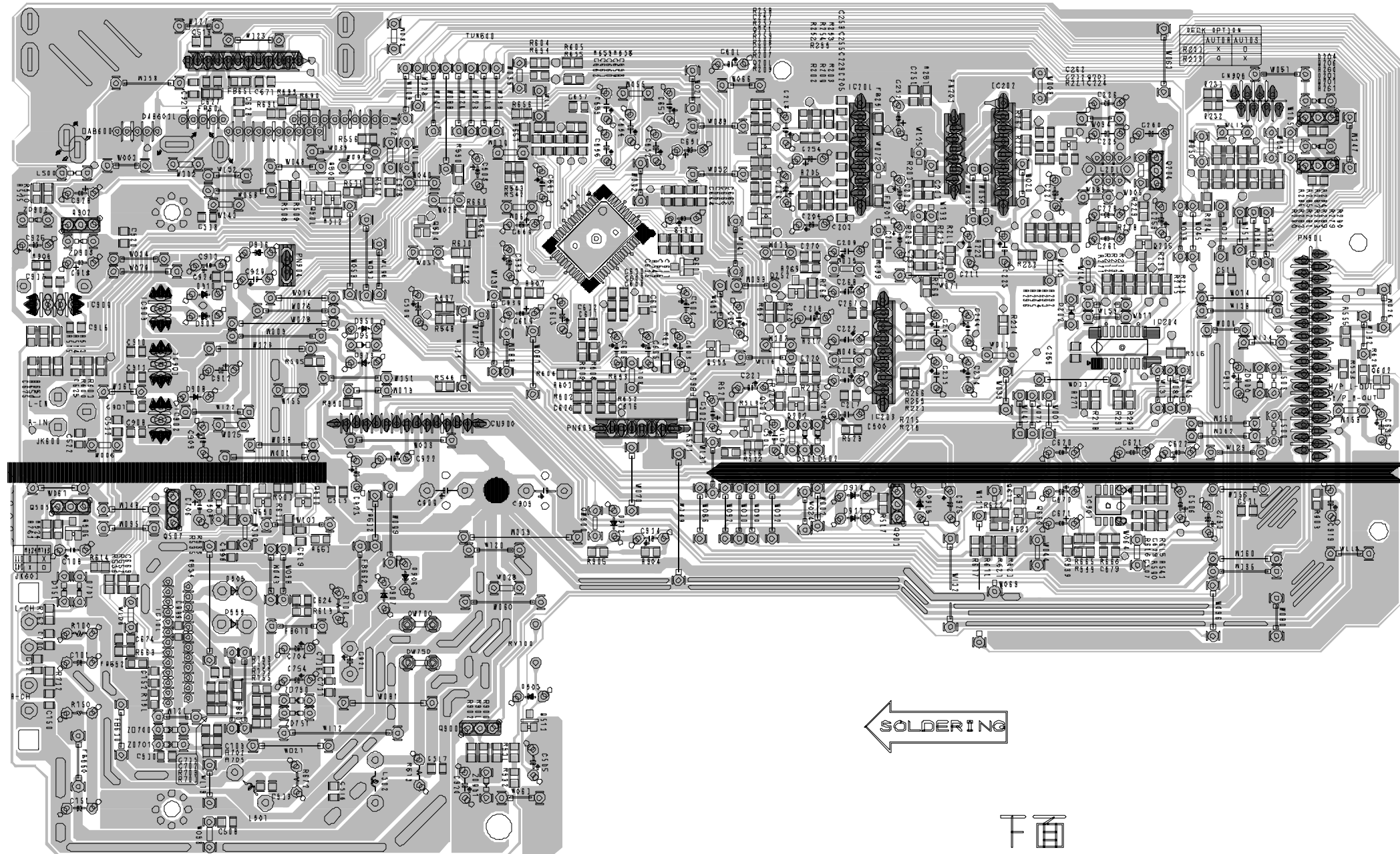

• FRONT P.C. BOARD

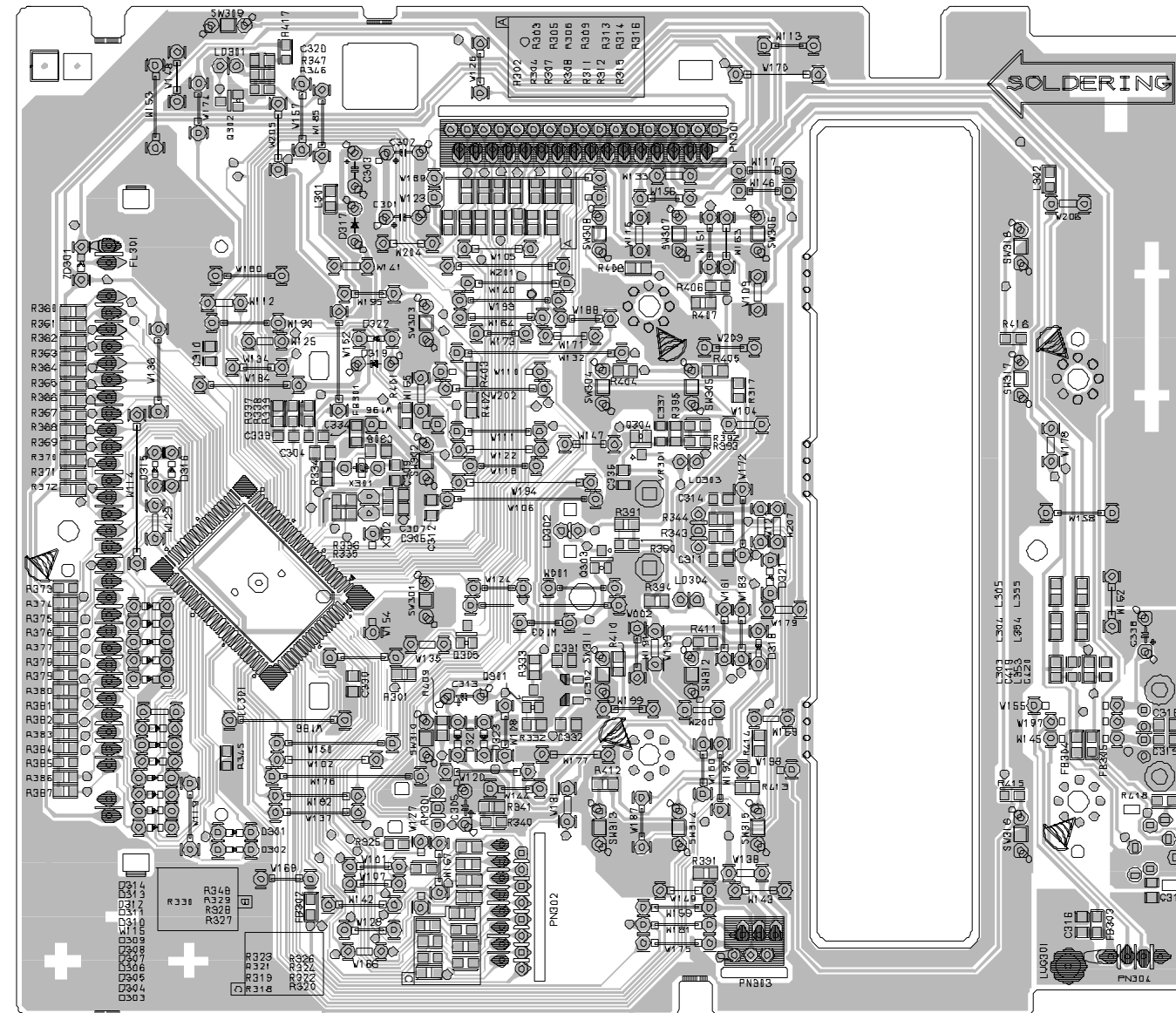

• CDP P.C. BOARD (COMPONENT SIDE)

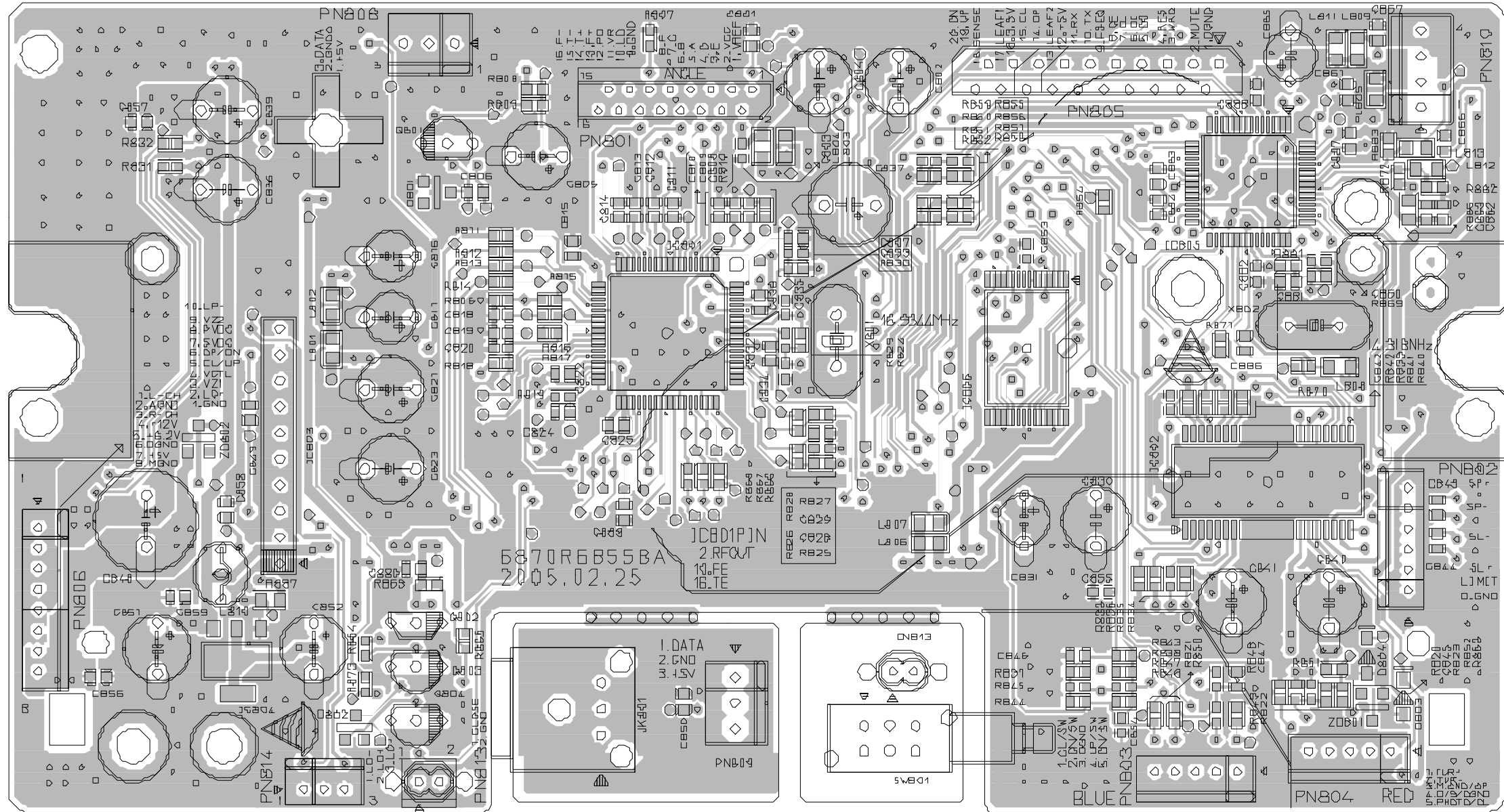

• LINEAR POWER

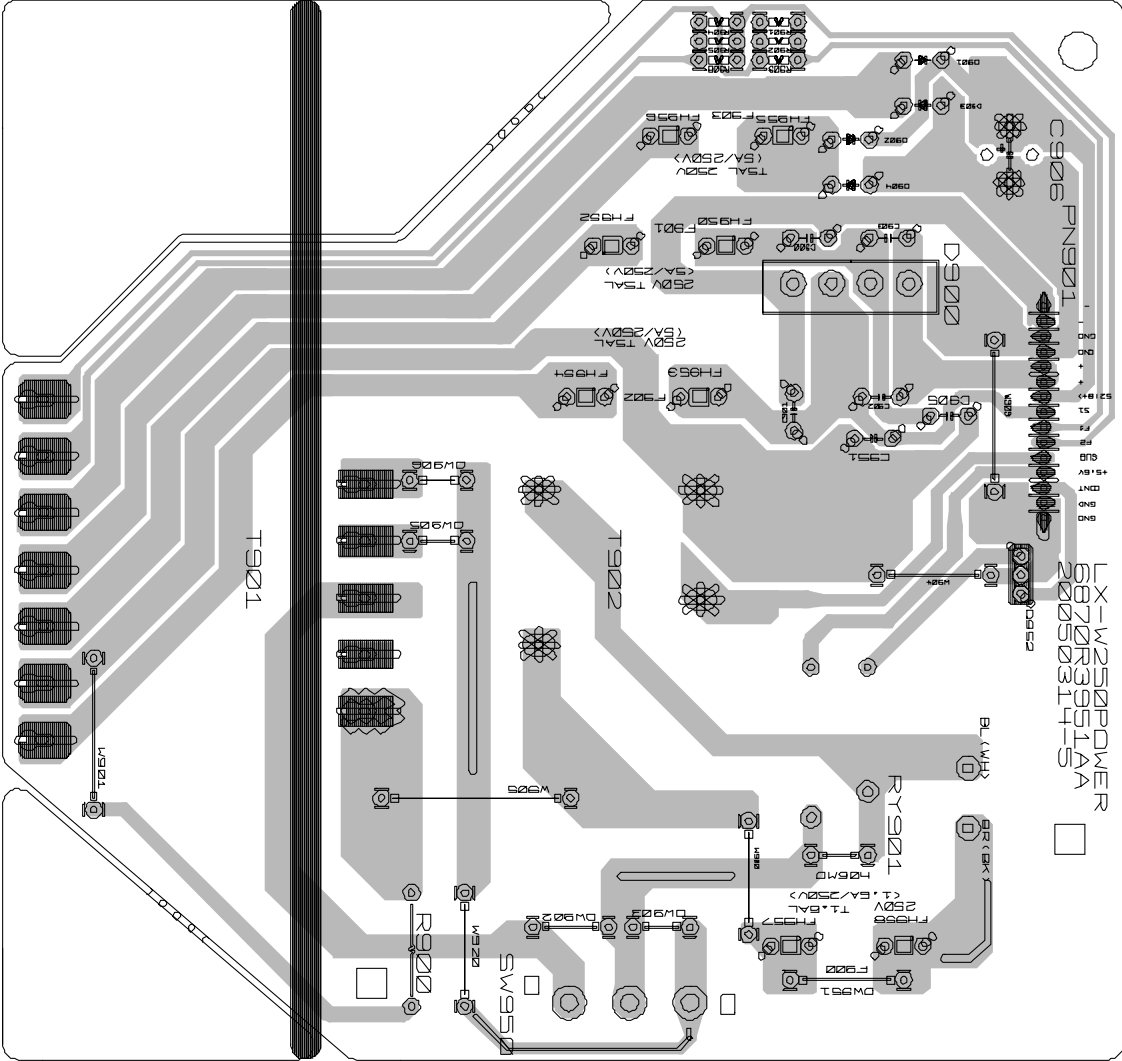

SECTION 3. EXPLODED VIEWS

CABINET AND MAIN FRAME SECTION

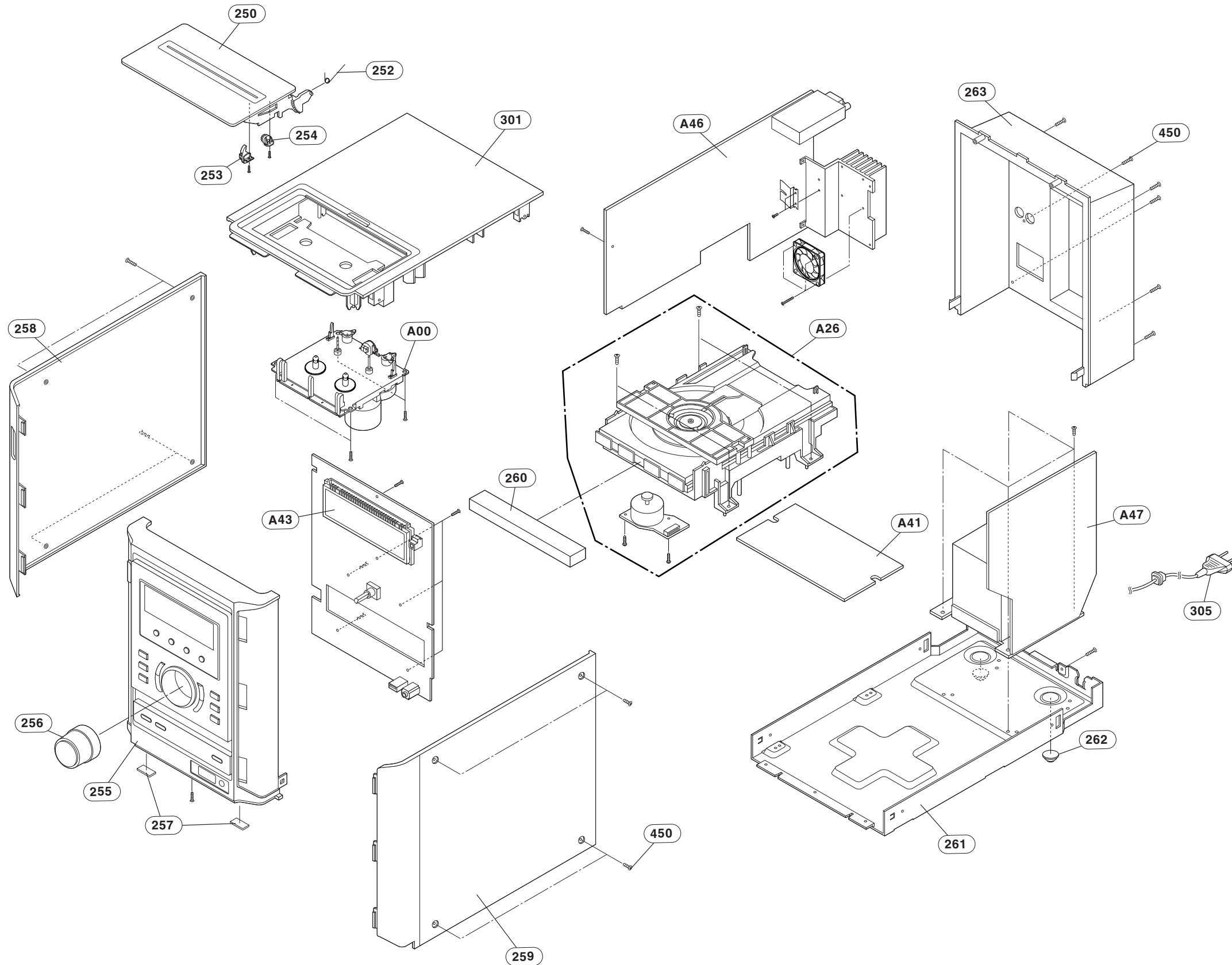

• SINGLE DECK MECHANISM

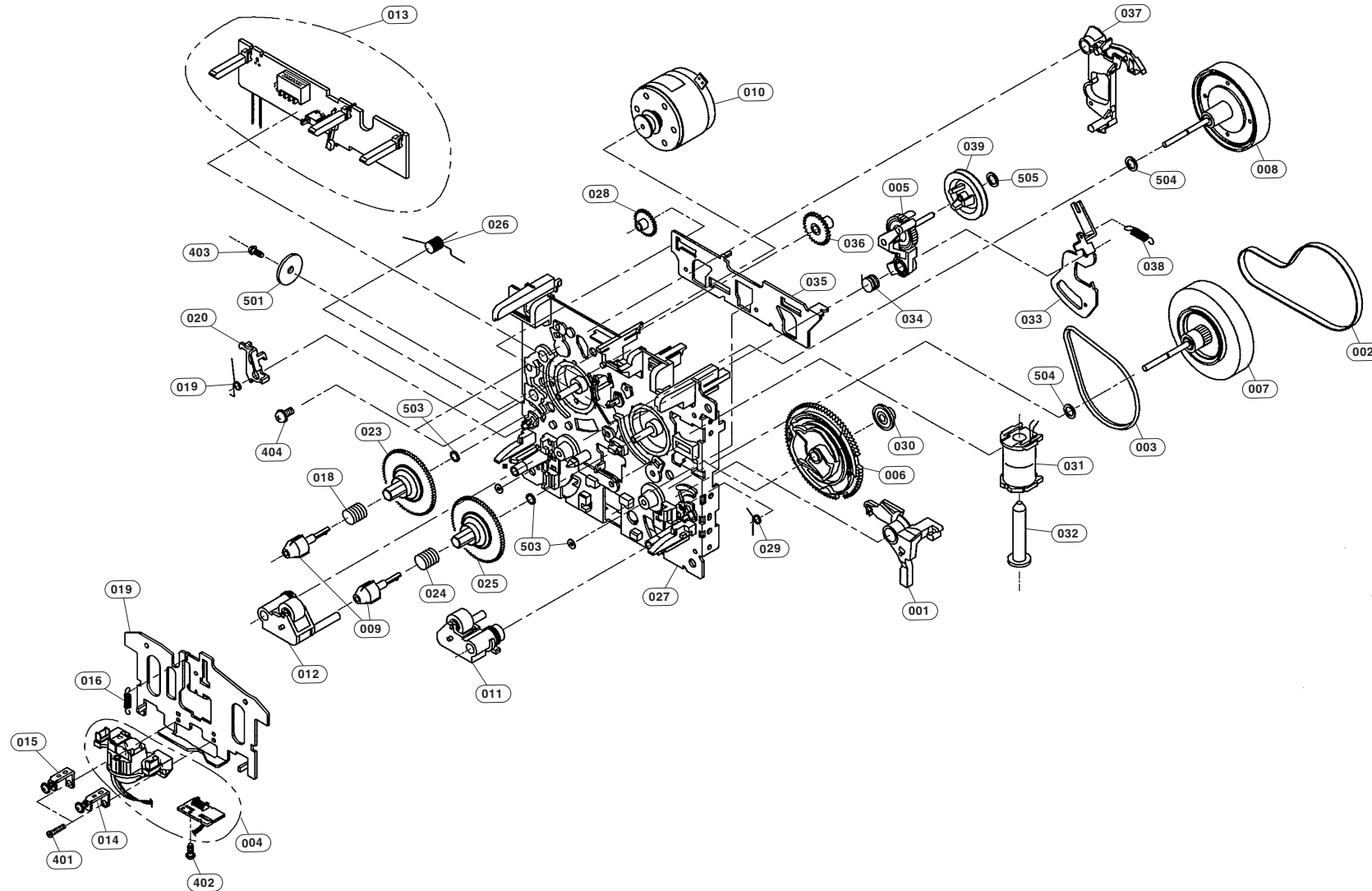

LOCA. NO.	LG PART NO.	DESCRIPTION	SPECIFICATION
A00	6720AF0007A	"DECK,AUDIO"	CMAL1Z2 ALPS L-SINGLE A/RVS
001	6768RZAA04A	DECK MECHANISM PARTS	FD58P- ALPS ARM PLAY
002	6768RZBA04A	DECK MECHANISM PARTS	FF19U-31 ALPS BELT/FELT A/R A/
003	6768RZBA05A	DECK MECHANISM PARTS	FF19S-31 ALPS BELT/FELT A/R
004	6768RZEA01A	DECK MECHANISM PARTS	F513-927 ALPS HEAD ASSY A/R
005	6768RZGA03A	DECK MECHANISM PARTS	F522-063 ALPS GEAR A/R A/S
006	6768RZGA04A	DECK MECHANISM PARTS	FD58M- ALPS GEAR CAM
007	6768RZJA03A	DECK MECHANISM PARTS	FR26D- ALPS PULLEY/FLYWHEEL AS
008	6768RZJA04A	DECK MECHANISM PARTS	FR25M- ALPS PULLEY/FLYWHEEL AS
009	6768RZMA02A	DECK MECHANISM PARTS	FD53M- ALPS MOLD REEL
010	6768RZQA03A	DECK MECHANISM PARTS	F525-381 ALPS MOTOR(ASSY) A/R
011	6768RZRA01A	DECK MECHANISM PARTS	F514-133 ALPS ROLLER A/R
012	6768RZRA02A	DECK MECHANISM PARTS	F514-134 ALPS ROLLER A/R
013	6768RZXA02A	DECK MECHANISM PARTS	F567-726 ALPS SPECIAL A/R
014	6768RZPA03A	DECK MECHANISM PARTS	F512-128 ALPS PRESS PLATE BASE
015	6768RZPA02A	DECK MECHANISM PARTS	F512-127 ALPS PRESS PLATE BASE
016	6768RZSA01A	DECK MECHANISM PARTS	FK32T- ALPS SPRING HB
017	6768RZPA04A	DECK MECHANISM PARTS	FC61K- ALPS PRESS HEAD BASE
018	6768RZSA04A	DECK MECHANISM PARTS	FK32U- ALPS SPRING REEL L
019	6768RZSA02A	DECK MECHANISM PARTS	FK32N- ALPS SPRING INTERLOCK L
020	6768RZAA05A	DECK MECHANISM PARTS	FC61P- AKPS ARM INTERLOCK L
023	6768RZMA04A	DECK MECHANISM PARTS	FD52W- ALPS MOLD REEL BASE RVS
024	6768RZSA05A	DECK MECHANISM PARTS	FK32V- ALPS SPRING REEL R
025	6768RZMA03A	DECK MECHANISM PARTS	FD52W- ALPS MOLD REEL BASE
026	6768RZSA03A	DECK MECHANISM PARTS	FK34Y- ALPS SPRING B/C
027	6768RZSA03A	DECK MECHANISM PARTS	FK34Y- ALPS SPRING B/C
028	6768RZPA05A	DECK MECHANISM PARTS	F612-234 ALPS PRESS CHASSIS BA
029	6768RZGA05A	DECK MECHANISM PARTS	FD53K- ALPS GEAR PLAY(A)
030	6768RZMA05A	DECK MECHANISM PARTS	FD59F- ALPS MOLD BUSH
031	6768RZVA01A	DECK MECHANISM PARTS	F765-303 ALPS SOLENOID BLK
032	6768RZVA02A	DECK MECHANISM PARTS	FL41S- ALPS SOLENOID PLUNGER
033	6768RZPA07A	DECK MECHANISM PARTS	FC65W- ALPS PRESS LEVER F/R
034	6768RZSA07A	DECK MECHANISM PARTS	FK35K- ALPS SPRING CAM
035	6768RZPA06A	DECK MECHANISM PARTS	FC61L- ALPS PRESS PLATE SLIDE
036	6768RZGA06A	DECK MECHANISM PARTS	FD60L- ALPS GEAR FF(E)
037	6768RZMA06A	DECK MECHANISM PARTS	FD58T- ALPS MOLD LEVER BRAKE
038	6768RZSA08A	DECK MECHANISM PARTS	FK35E- ALPS SPRING ARM F/R
039	6768RZJA06A	DECK MECHANISM PARTS	FD60B- ALPS PULLEY/FLYWHEEL AS
401	6768RZCA01A	DECK MECHANISM PARTS	KG194E36A ALPS SCREW 2.0X6
402	6768RZCA02A	DECK MECHANISM PARTS	KG194E34A ALPS SCREW 2.0X4
403	6768RZCA03A	DECK MECHANISM PARTS	KG194E28 ALPS SCREW 2.6X4
404	6768RZCA04A	DECK MECHANISM PARTS	FG114E14A ALPS SCREW 2.6X5
501	6768RZWA01A	DECK MECHANISM PARTS	FC67N- ALPS WASHER BRACKET DEC
502	6768RZWA02A	DECK MECHANISM PARTS	UJ16F- ALPS WASHER 1.75X0.4
503	6768RZWA03A	DECK MECHANISM PARTS	FJ111-35 ALPS WASHER 4.1X0.25
504	6768RZWA04A	DECK MECHANISM PARTS	FJ111-30 ALPS WASHER 2.6X0.25
505	6768RZWA05A	DECK MECHANISM PARTS	FJ111-17 ALPS WASHER 1.7X0.25

• CD MECHANISM

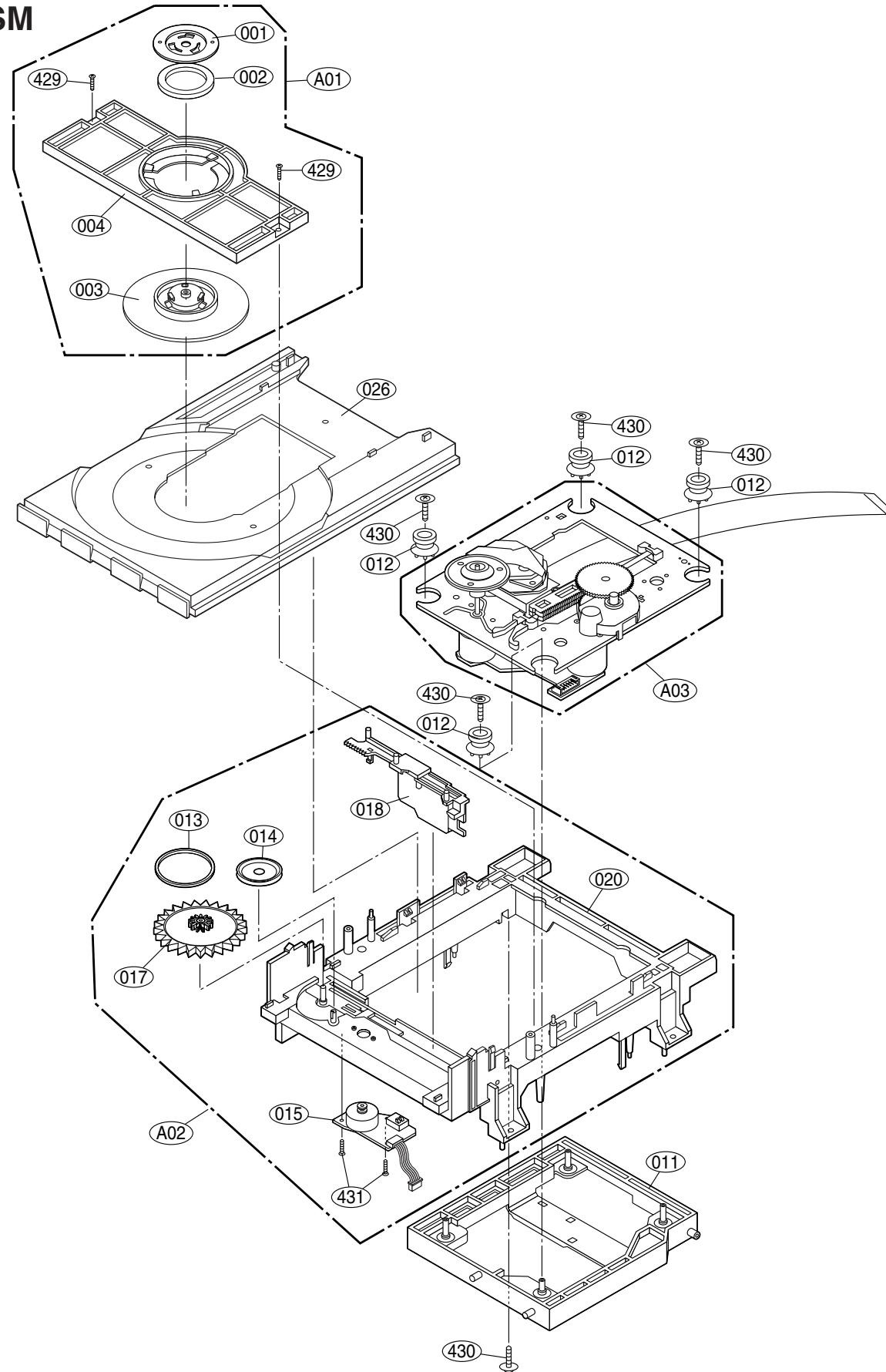

LOCA. NO.	LG PART NO.	DESCRIPTION	SPECIFICATION
A26	6721RJ0570A	DECK ASSEMBLY,AUDIO	HOME LX-W550(W250)/LF-U850-HZ
A01	4860RB0002B	CLAMP	HOME CDM-H1503 MOLD CLAMP ASSY
A02	4405RCD002A	MECHANISM ASSEMBLY	MAIN LOADING CDM-310 CDP
A03	6717R-A002A	PICK UP ASSEMBLY	CMS-D77SG6 SAMSUNG TOP LOADING
001	3550SB0001A	COVER	HOME PLATE PRESS (CDM-H1303)
002	524-012AAAA	COVER	HOME CLAMP MAGNET OTHER (030X
003	4860RB0002A	CLAMP	HOME CDM-H1503 MOLD DISC
004	4930R-0526A	HOLDER	HOME CDM-310 MOLD CLAMP
011	3040R-0073A	BASE	P/U (CDM-300)
012	5040R-0131A	RUBBER	HOME CDM-310 OTHER DAMPER
013	4400R-0006B	BELT	DECK/MECHA DP2-5, DP7C,DP7A OT
014	4470R-0055A	GEAR	PULLEY
015	6871RC2016A	PWB(PCB)ASSEMBLY,CD	LOADING(CDM-300)
017	4470R-0056A	GEAR	LOADING
018	4974R-0023A	GUIDE	UP/DOWN
020	3040R-M059A	BASE	MAIN CDM-310 MOLD
026	3390R-0028A	TRAY	HOME CDM-310 MOLD DISC
429	1SZZR-0012A	SCREW,DRAWING	B-TITE
430	6756SBX001A	CD MECHANISM PARTS	SCREW 2.6X10X10XFZMY CDM-H813
431	1SZZH-1007B	SCREW,DRAWING	+ D2.0 6MM SWRCH16A/ZNBK 4MM 1

SECTION 4. SPEAKER SECTION

MODEL: LXS-U250

