

Service Manual

General Description
Adjustment Procedures
Block / Schematic Diagrams
Exploded Views / Parts List

Digital Versatile Disc



CLASS 1
LASER PRODUCT

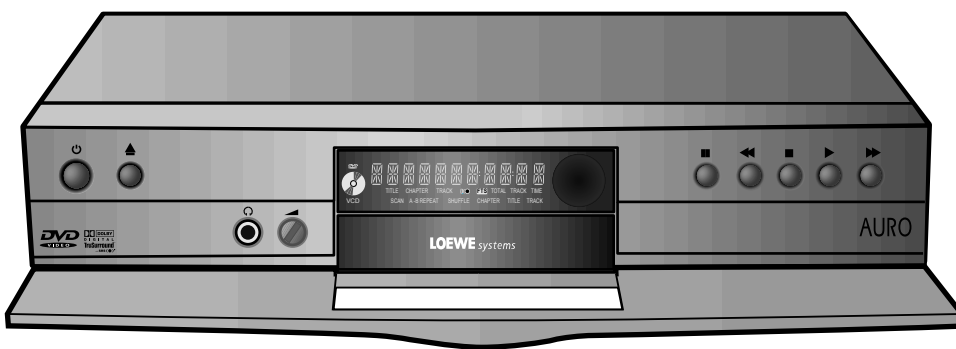

LOEWE systems
DVD-Player
Auro
Art.-Nr. 59502

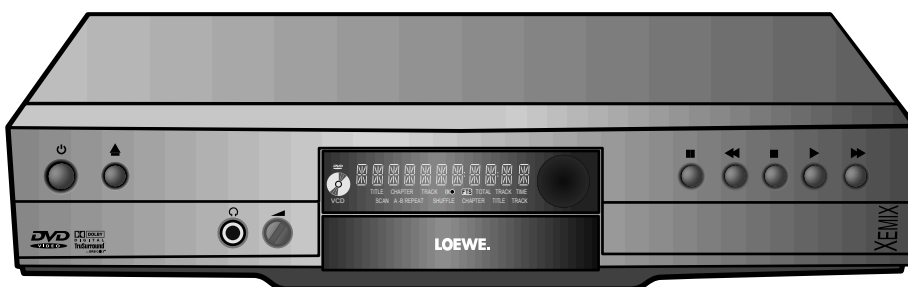

LOEWE.
DVD-Player
Xemix
Art.-Nr. 59501

LOEWE.

GB 230-90347.911

1. Technical specifications

1.1 General:

Mains voltage	: 230V (196 - 263V AC)
Mains frequency	: 50 Hz -60Hz
Power consumption	: 20W
Power consumption standby	: <10W (≤5W for low power standby; without P50)

1.2 Audio performance

Test equipment	: Audio Precision
Testdiscs	: CDDA: Philips audio signal testdisc 1 : VCD: Philips A/V testdisc & ABEX A/V testdisc : DVD: Philips LVP09.00 audio testdisc

1.3 Line output

1.3.1 'Normal' mode (stereo)

Output voltage	:
2 channel mode	: 2Vrms +/- 1.5dB
5.1 channel Dolby	: 1.41 +/- 1.5 dB
Channel unbalance (1kHz)	: <0.85dB
Crosstalk	:
1kHz	: >105dB
20Hz-20kHz	: > 95dB
Frequency response	:
20Hz- 12kHz	: +/- 0.1dB max
Signal to noise ratio	: >100 dB
Dynamic range	:
1kHz	: >90dB
20Hz-20kHz	: >88dB
Distortion and noise	:
1kHz	: >90dB
20Hz-20kHz	: >80dB
Intermodulation distortion	: >87dB
Phase non linearity	: +/- 1° max.
Level non linearity	: +/- 0.5dB max.
Mute (spin-up, pause, access)	: >100dB
Outband attenuation	: > 50dB above 25kHz

1.3.2 'Center on' mode (mono)

Output voltage	: 2Vrms typ
Channel unbalance (1kHz)	: <0.85dB
Crosstalk:	: mono
Frequency response(20Hz- 12kHz)	: 0.1dB max
Signal to noise ratio	: >85 dB
Dynamic range 20Hz-20kHz	: >85 dB
Distortion and noise 20Hz-20kHz	: >80 dB
Intermodulation distortion	: >87 dB
Phase non linearity	: not applicable
Level non linearity	: +/- 1 dB
Mute (spin-up, pause, access)	: >100dB
Outband attenuation	: > 50dB above 25kHz
Centerdelay adjusting	: 0-5 msec (steps 1 msec)

1.6 Video performance

1.4 6-channel output

1.4.1 Front Line out(channel 1 and 2)

fully according to PQR class III	:
Output voltage	:
channel mode	: 1.41Vrms +/- 1.5dB
5.1 channel Dolby	: 1.41V +/- 1.5 dB
Channel unbalance (1kHz)	: <0.85dB
Crosstalk	:
1kHz	: >105dB
20Hz-20kHz	: > 95dB
Frequency response 20Hz- 12kHz	: +/- 0.1dB max
Signal to noise ratio	: >100 dB
Dynamic range	:
1kHz	: >90dB
20Hz-20kHz	: >88dB
Distortion and noise	:
1kHz	: >90dB
20Hz-20kHz	: >80dB
Intermodulation distortion	: >87dB
Phase non linearity	: +/- 1° max.
Level non linearity	: +/- 0.5dB max.
Mute (spin-up, pause, access)	: >100dB
Outband attenuation	: > 50dB above 25kHz

1.4.2 Surround channels (channel 3,4,5 and 6)

Surround channels are according to dolby group C products (*1)	:
Testequipment: audio precision (*2)	:
LFE + Center + Rear line out	:
Output voltage	:
2 channel mode	: muted
5.1 channel Dolby	: 1.41Vrms +/-1.5dB : Adjustable 0.7V-2.82 V
	: (+/- 6dB to front channels)
Channel unbalance	: <0.85 dB
Signal to noise ratio	: >100 dB (A-weighted)
Dynamic range	: >85 dB
Distortion and noise	: >80 dB (90 typical)
Crosstalk:	: >95 dB (*3)
*1	: referenced to dolby digital licensee information manual version 2.0
*2	: measured in normal mode and with balance control neutral
*3	: crosstalk from channels 1,3,5(channel 1 is ref) to 2,4,6(measured channels)

1.5 Headphone output

According PQR1 IMS	:
30mW at 32 Ohm load.	:
Headphone impedance: 8-2000 Ohm	:

VCD testdisc	: Philips A/V disc & ABEX A/V disc
--------------	------------------------------------

DVD testdisc : Philips MPTD PAL
CVP0213 / Philips
LVP10.00 video
testdisc

1.6.1 CVBS

Fully according PQR3 IMS
Video output : 1Vpp(0.1V into 75
Ohm)

1.6.2 S-video (Y/C)

Fully according PQR3 IMS
1 - GND
2 - GND
3 - Y 1Vpp +/- 0.1V into 75 Ohm
4 - C burst 300mVpp +1/-4dB into 75
Ohm
Aspect ratio switching by DC on C(pin4).
Connector type : 4 pin mini- DIN

1.7 Scart

Fully according PQR3 IMS
Connector implementation according EN50049-1; color =
black; dual SCART
Fully according to prEN1057-2-1
Signal switching is P50 controlled; supported features of mode
3 see survey of applicable standards.

1.7.1 SCART II (connected to TV)

Pin signals:
1 - Audio R 1.8V RMS
2 - Audio R
3 - Audio L 1.8V RMS
4 - Audio GND
5 - Blue/Chroma GND
6 - Audio L
7 - Blue out/
Chroma in 0.7Vpp +/- 0.1V into 75 Ohm (*)
8 - Function
switch <2V = TV
>4.5V / <7V = asp. ratio 16:9 DVD
>9.5V / <12V = asp. ratio 4:3 DVD
9 - Green GND
10- Nc
11- Green 0.7Vpp +/- 0.1V into 75 Ohm (*)
12- Nc
13- Red/Chroma GND
14- Fast switch GND
15- Red out/
Chroma out 0.7Vpp +/- 0.1V into 75 Ohm (*)
+/- 3dB 0.3Vpp in case of Chroma
16- Fast switch
RGB/ CVBS or Y <0.4V into 75 Ohm = CVBS
>1V / <3V into 75 Ohm = RGB
17- Y/CVBS GND
18- Fast
switching GND
19- CVBS/Y/RGB
sync 1Vpp +/- 0.1V into 75 Ohm (*)
20- CVBS/Y
21- Shield

1.7.2 SCART I (connected to AUX)

Pin signals:
1 - Audio R 1.8V RMS

2 - Audio R
3 - Audio L 1.8V RMS
4 - Audio GND
5 - Blue/Chroma GND
6 - Audio L
7 - Blue in/
Chroma out +/- 3dB 0.3vpp Chroma (burst)
8 - Function
switch
9 - Green GND
10- P50 Control
11- Green
12- Nc
13- Red/Chroma GND
14- Fast switch GND
15- Red in/
Chroma in
16- Fast switch
RGB/ CVBS
or Y
17- CVBS GND
18- Fast
switching GND
19- CVBS/Y/RGB
sync 1Vpp +/- 0.1V into 75 Ohm (*)
20- CVBS/Y
21- Shield
(* for 100% white

1.8 Digital output

1.8.1 Coaxial

CDDA/ LPCM (incl MPEG1) : According IEC958
MPEG2, AC3 audio : According IEC1937
Remark:
DTS audio output mode is only available on "digital out"

1.8.2 Optical

Identical to coaxial

1.9 Dimensions and weight

Place and height of feet : acc. to Loewe
Harmonisation line
Apparatus tray closed : WxDxH: 435 x 315x
75/88
Apparatus tray open : WxDxH: 435 x 442 x
75/88
Weight without packaging : ca. 4 Kg
Weight in packaging : ca. 6 Kg

1.10 Laser output power & wavelength

1.10.1 DVD

Output power : 7mW
Wavelength : 650nm

1.10.2 CD

Output power : 10mW
Wavelength : 785nm

2. Warnings and Laser safety instructions

GB WARNING

All ICs and many other semi-conductors are susceptible to electrostatic discharges (ESD). Careless handling during repair can reduce life drastically.

When repairing, make sure that you are connected with the same potential as the mass of the set via a wrist wrap with resistance.

Keep components and tools also at this potential.

ESD



NL WAARSCHUWING

Alle IC's en vele andere halfgeleiders zijn gevoelig voor elektrostatische ontladingen (ESD).

Onzorgvuldig behandelen tijdens reparatie kan de levensduur drastisch doen verminderen.

Zorg ervoor dat u tijdens reparatie via een polsband met weerstand verbonden bent met hetzelfde potentiaal als de massa van het apparaat.

Houd componenten en hulpmiddelen ook op hetzelfde potentiaal.

F ATTENTION

Tous les IC et beaucoup d'autres semi-conducteurs sont sensibles aux décharges statiques (ESD).

Leur longévité pourrait être considérablement écourtée par le fait qu'aucune précaution n'est prise à leur manipulation.

Lors de réparations, s'assurer de bien être relié au même potentiel que la masse de l'appareil et enfiler le bracelet serti d'une résistance de sécurité.

Veiller à ce que les composants ainsi que les outils que l'on utilise soient également à ce potentiel.

D WARNUNG

Alle IC und viele andere Halbleiter sind empfindlich gegen elektrostatische Entladungen (ESD).

Unvorsichtige Behandlung bei der Reparatur kann die Lebensdauer drastisch vermindern.

Sorgen sie dafür, das Sie im Reparaturfall über ein Pulsarmband mit Widerstand mit dem Massepotential des Gerätes verbunden sind.

Halten Sie Bauteile und Hilfsmittel ebenfalls auf diesem Potential.

I AVVERTIMENTO

Tutti IC e parecchi semi-conduttori sono sensibili alle scariche statiche (ESD).

La loro longevita potrebbe essere fortemente ridatta in caso di non osservazione della piu grande cauzione alla loro manipolazione.

Durante le riparazioni occorre quindi essere collegato allo stesso potenziale che quello della massa dell'apparecchio tramite un braccialetto a resistenza.

Assicurarsi che i componenti e anche gli utensili con quali si lavora siano anche a questo potenziale.

GB

Safety regulations require that the set be restored to its original condition and that parts which are identical with those specified be used.

NL

Veiligheidsbepalingen vereisen, dat het apparaat in zijn oorspronkelijke toestand wordt terug gebracht en dat onderdelen, identiek aan de gespecificeerde worden toegepast.

D

Bei jeder Reparatur sind die geltenden Sicherheitsvorschriften zu beachten. Der Originalzustand des Gerats darf nicht verändert werden. Für Reparaturen sind Original-Ersatzteile zu verwenden.

I

Le norme di sicurezza esigono che l'apparecchio venga rimesso nelle condizioni originali e che siano utilizzati pezzi di ricambiaggio idetici a quelli specificati.

F

Les normes de sécurité exigent que l'appareil soit remis à l'état d'origine et que soient utilisées les pièces de rechange identiques à celles spécifiées.

SHOCK, FIRE HAZARD SERVICE TEST:

CAUTION: After servicing this appliance and prior to returning to customer, measure the resistance between either primary AC cord connector pins (with unit NOT connected to AC mains and its Power switch ON), and the face or Front Panel of product and controls and chassis bottom,

Any resistance measurement less than 1 Megohms should cause unit to be repaired or corrected before AC power is applied, and verified before return to user/customer.

Ref.UL Standard NO.1492.

NOTE ON SAFETY:

Symbol : Fire or electrical shock hazard. Only original parts should be used to replace any part with symbol Any other component substitution (other than original type), may increase risk or fire or electrical shock hazard.

LASER SAFETY

This unit employs a laser. Only a qualified service person should remove the cover or attempt to service this device, due to possible eye injury.

LASER DEVICE UNIT

Type:	SemiconductorlaserGaAIAs
Wave length:	650 nm (DVD) 780 nm (VCD/CD)
Output Power:	7 mW (DVD) 10 mW (VCD/CD)
Beam divergence:	60 degree



USE OF CONTROLS OR ADJUSTMENTS OR PERFORMANCE OF PROCEDURE OTHER THAN THOSE SPECIFIED HEREIN MAY RESULT IN HAZARDOUS RADIATION EXPOSURE.

AVOID DIRECT EXPOSURE TO BEAM

WARNING

The use of optical instruments with this product will increase eye hazard.
Repair handling should take place as much as possible with a disc loaded inside the player

WARNING LOCATION: INSIDE ON LASER COVERSIELD

CAUTION VISIBLE AND INVISIBLE LASER RADIATION WHEN OPEN AVOID EXPOSURE TO BEAM
ADVARSEL SYNLIG OG USYNLIG LASERSTRÅLING VED ÅBNING UNDGÅ UDSÆTTELSE FOR STRÅLING
ADVARSEL SYNLIG OG USYNLIG LASERSTRÅLING NÅR DEKSEL ÅPNES UNNGÅ EKSPONERING FOR STRÅLEN
VARNING SYNLIG OCH OSYNLIG LASERSTRÅLNING NÅR DENNA DEL ÅR ÖPPNAD BETRakta EJ STRÅLEN
VARO! AVATT AESSA OLET ALTTIINA NÄKYVÄLLE JA NÄKYMÄTT ÖMÄLLE LASER SÄTEILYLLE. ÄLÄ KATSO SÄTEESEEN
VORSICHT SICHTBARE UND UNSICHTBARE LASERSTRAHLUNG WENN ABDECKUNG GEÖFFNET NICHT DEM STRAHL AUSSETZEN
DANGER VISIBLE AND INVISIBLE LASER RADIATION WHEN OPEN AVOID DIRECT EXPOSURE TO BEAM
ATTENTION RAYONNEMENT LASER VISIBLE ET INVISIBLE EN CAS D'OUVERTURE EXPOSITION DANGEREUSE AU FAISCEAU

Warning for powersupply on position 1005

The primary side of the powersupply including the heatsink carries live mains voltage when the player is connected to the mains even when the player is switched off !

This primary area is not shielded so it is possible to touch copper tracks and/or components when servicing the player. Service personnel have to take precautions to prevent touching this area or components in this area .

The primary side of the powersupply has been indicated with a lightning stroke and a stripe-marked printed on the printed wiring board

Note:

The screws on the basic Engine (position 82 in on the exploded view drawing) may never be touched removed or re-adjusted.

Handle the Basic engine with care when the unit has to be exchanged!

The mechanism of the basic engine is very sensitive for dropping or shocks

3. Service hints

The DVD module(Basic Engine and the mono board) has to be exchanged completely in case of failure. A new module for Xemix can be ordered with codenumber 291-90350.969 for Region Code 4 (Australia), 291-90350.970 for Region Code 5 (Russia), and 291-90350.968 for all European countries Region Code 2. A new module for Auro can be ordered with codenumber 291-90350.988 for Region Code 4 (Australia), 291-90350.989 for Region Code 5 (Russia),and 291-90350.987 for all European countries Region Code 2.

Return the defective unit complete assembled in original package to Loewe Consumer Service in Kronach.

6. DIAGNOSTIC SOFTWARE : SCRIPT INTERFACES

6.1 DEALER SCRIPT

6.1.2 Contents of Dealer Script

6.1.1 Purpose of Dealer Script

The dealer script can give a diagnosis on a standalone DVD player; no other equipment is needed to perform a number of hardware tests to check if the DVD player is faulty. The diagnosis is simply a "error" or "pass" message; no indication is given of faulty hardware modules. Only tests within the scope of the diagnostic software will be executed hence only faults within this scope can be detected.

The dealer script executes all diagnostic nuclei that do not need any user interaction and are meaningful on a standalone DVD player.

The nuclei called in the dealer script are the following (the number after each nucleus name corresponds with the number being on the local display when the nucleus is executed during the dealer script):

Nucleus		Description
VideoColSetupComm	9	Checks the I2C interface with the RGB video processor on the Audio/Video board (only for DVD players with RGB video processor).
VideoScartSwComm	8	Checks the I2C interface with the scart switch on the Audio/Video board
PapChksFl	7	Calculate and verify checksum of FLASH memory.
PapDramWrR	6	Pattern test of all locations in the DRAM(s).
PapI2cDisp	5	Checks the I2C interface with the slave processor on the display PCB.
PapS2bEcho	4	Checks the I2C interface to the basic engine.
PapI2cNvram	3	Checks the I2C interface with the NVRAM.
PapNvramWrR	2	Pattern test of all locations in the NVRAM
CompSdramWrR	1	Pattern test of all locations in the SDRAM(s).

CL 96532065_001.eps
120799

Figure 6-1

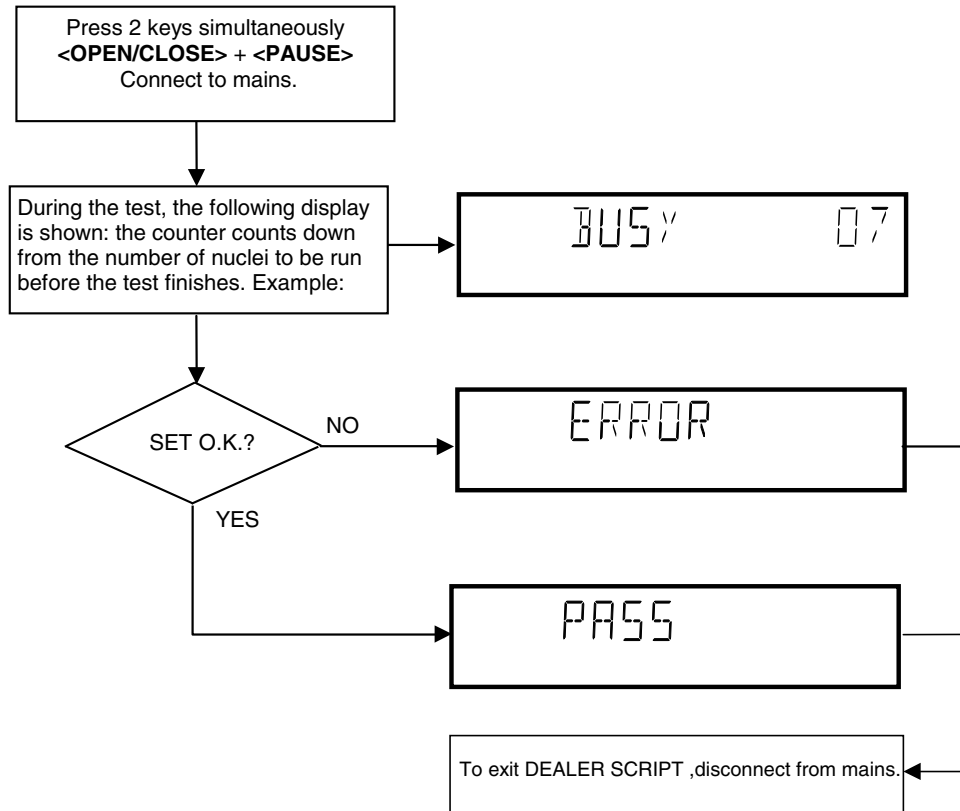

CL96532126_013.eps
261099

Figure 6-2

6.2 PLAYER SCRIPT

6.2.1 Purpose of Player Script

The Player script will give the opportunity to perform a test that will determine which of the DVD player's modules are faulty, to read the error log and error bits and to perform an endurance loop test. To successfully perform the tests, the DVD player must be connected to a tv set to check the output of a number of nuclei. For DVDv2b a multi-channel amplifier, a set of 6 boxes and an external video source are necessary to test. To be able to check results of certain nuclei, the player script expects some interaction of the user (i.e. to approve a test picture or a test sound). Some nuclei (e.g. nuclei that test functionality of the Basic Engine module) require that the DVD player itself is opened, to enable the user to observe moving parts and approve their movement visually. Only tests within the scope of the diagnostic software will be executed hence only faults within this scope can be detected.

6.2.2 Contents of Player Script

The player script contains all nuclei that are useful on a DVD player that is connected to a tv-set and help to determine which module of the DVD player is faulty, as well as to read out the contents of the error logs.

6.2.3 Structure of Player Script

The player script consists of a set of nuclei testing the three hardware modules in the DVD player: the Display PWB, the Digital PWB and the Basic Engine. Nuclei run by the player test need some user interaction; in the next paragraph this interaction is described. The player test is done in two phases:

1. Interactive tests: this part of the player test depends strongly on user interaction and input to determine nucleus results and to progress through the full test. Reading the error log and error bits information can be useful to determine any errors that occurred recently during normal operation of the DVD player.
2. The loop test will perform the same nuclei as the dealer test, but it will loop through the list of nuclei indefinitely.

6.2.4 Survey

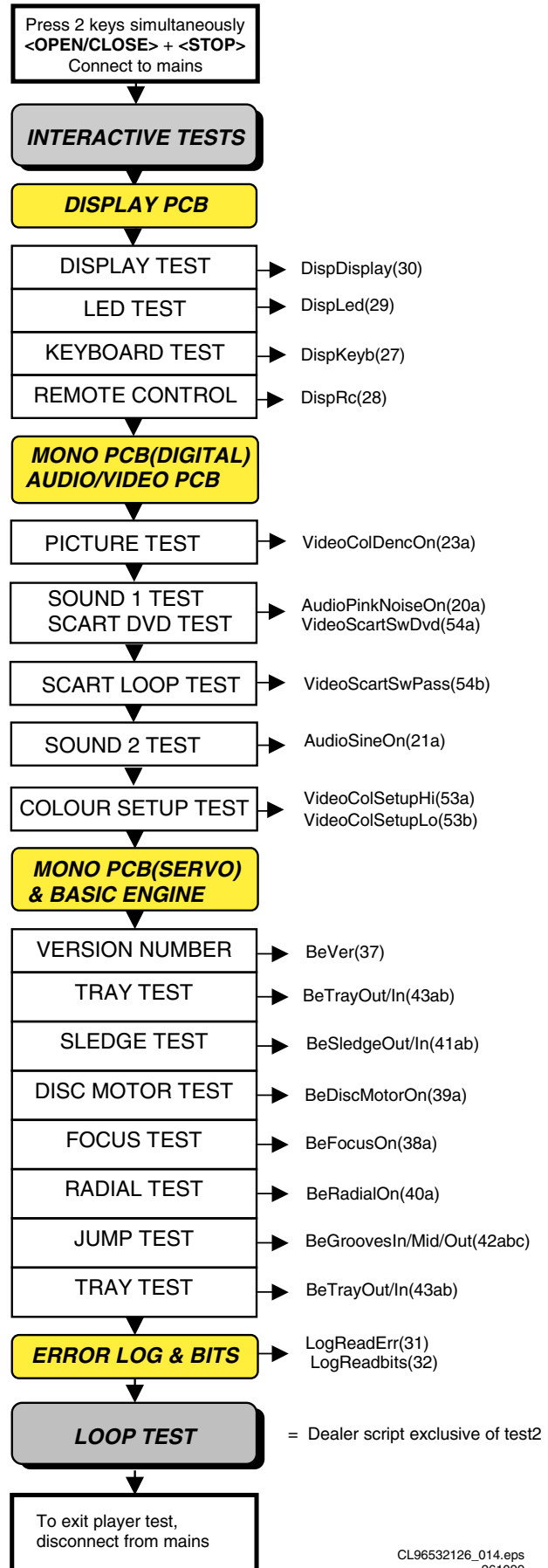

Figure 6-3

6.3 INTERACTIVE TESTS

6.3.1 DISPLAY PCB

DISPLAY TEST

The display test is performed by nucleus DispDisplay. By putting a series of test patterns on the local display, the local display is tested. To step through all different patterns, the user must either press PLAY (pattern is ok) or PAUSE (pattern was incorrect) to proceed to the next pattern. The display of patterns is continued in a cyclic manner until the user presses NEXT. If the user presses NEXT before all display patterns are tested, the DispDisplay nucleus will return TRUE (display test successful).

LED TEST

The LED(s) on the DVD player is (are) tested by nucleus DispLed. The user must check if the LED(s) is (are) lighted; if it is, press PLAY, if it is not, press PAUSE. By pressing NEXT the script will proceed to the next test. If the user presses NEXT before PLAY or PAUSE, the DispLed nucleus will return TRUE (LED test successful).

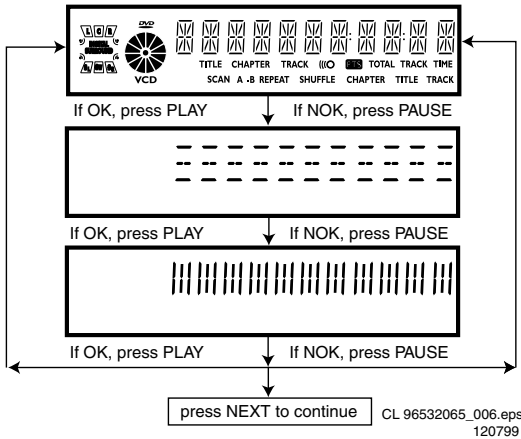

Figure 6-4

KEYBOARD TEST

The keyboard of the DVD player is tested by nucleus DispKeyb. The user is expected to press all keys on the local keyboard once. The code of the key pressed is shown on the local display (1 hexadecimal digit) immediately followed by a (hexadecimal) number indicating how many times that key has been pressed. Example of the local display during this test:

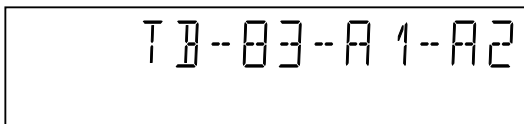

Figure 6-5

The key-codes displayed on the local display will scroll from right to left when the display gets full, the text "tb-" will remain on display.

key id.	key
0	PLAY
1	NEXT
2	PREVIOUS
3	PAUSE
4	STOP
5	OPEN/CLOSE
6	3D-SOUND
A	STANDBY

CL96532126_015.eps
261099

Figure 6-6

If any keys are detected more than once (due to hardware error), the key-code is displayed twice (or more), with the second digit increased by 1. If the user does not press all keys minimally once (in any order), the DispKeys nucleus will return FALSE and cause an error in the overall result of the player script. The user can leave the keyboard test by pressing the NEXT key on the local display of the DVD player for at least one full second. The result of the keyboard test is shown on local display as follows:

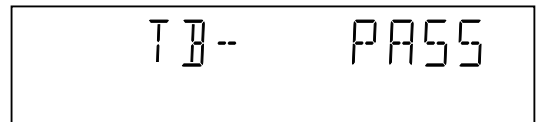

CL 96532065_009.eps
120799

Figure 6-7

Or

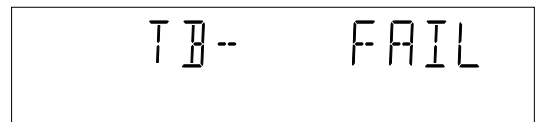

CL 96532065_010.eps
120799

Figure 6-8

Pressing NEXT on the local keyboard again will proceed to the next text.

REMOTE CONTROL TEST

The remote control of the DVD player is tested by nucleus DispRc. The user must press any key on the remote control just once. The codes of the key pressed will be shown on the local display in hexadecimal format. Example:

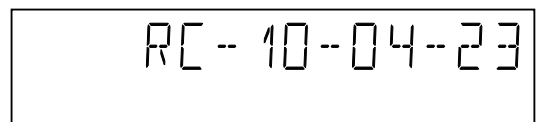

CL 96532065_011.eps
120799

Figure 6-9

In this example 23 is the hexadecimal code of the pressed RC key. The user can leave the remote-control test by pressing NEXT on the local keyboard of the DVD player. The remote control test is successful if a code was received before the user pressed the NEXT key; pressing the NEXT key before pressing a key on the remote control gives an error in the remote control

test (note that the remote control test will also fail if a key on the remote control was pressed but no code was received). The remote control test does not check upon the contents of the received code, that is it will not be checked if the received code matches the key pressed. If desired, the user can manually check this code by using a code-table for the remote control key-codes.

RC Key id	Hexadecimal code
STANDBY	C
STOP	31
PLAY	2C
PLAY BACKWARD	2D
PAUSE	30
STEP FORWARD	F6
STEP BACKWARD	F5
FORWARD	28
FORWARD 4X	DF
FORWARD 8X	E0
BACKWARD	29
BACKWARD 4X	DE
BACKWARD 8X	DD
SLOW	22
SLOW 2	D8
SLOW BACKWARD	23
SLOW BACKWARD 2	DB
NEXT	20
PREVIOUS	21
CURSOR UP	58
CURSOR DOWN	59
CURSOR LEFT	5A
CURSOR RIGHT	5B
OK	5C
0	0
1	1
2	2
3	3
4	4
5	5
6	6
7	7
8	8
9	9
TOGGLE	C8
ANGLE	85
AUDIO	4E
SUBTITLES	4B
SUBTITLE ON/OFF	E3
ROOT MENU	54
TITLE MENU	71
MENU	D1
SETUP MENU	82
OSD ON/OFF	F
RETURN	83
RESUME	D7
SCAN	2A
SHUFFLE	1C
REPEAT	1D
A/B REPEAT	3D
TOGGLE SCART	43
OPEN/CLOSE	42
FTS	FB
KARAOKE	E4
OPTION	FA

CL 96532065_012.eps
120799

Figure 6-10

After pressing NEXT, the result of the remote control test is displayed on the local display of the DVD player as follows:

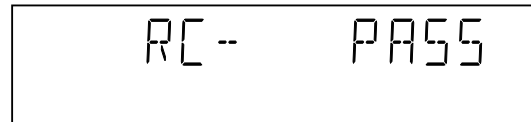

CL 96532065_013.eps
120799

Figure 6-11

Or

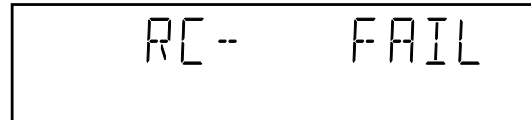

CL 96532065_014.eps
120799

Figure 6-12

Pressing NEXT on the local keyboard again will proceed to the next test.

6.3.2 MONO PCB DIGITAL PART

PICTURE TEST

The picture test is performed by putting a predefined picture (colour bar) on the display (nucleus VideoColDencOn) and asking the user for confirmation. The display will show the following message:

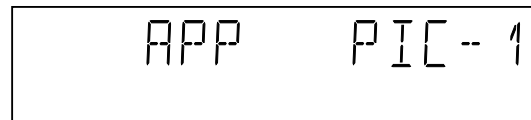

CL 96532065_015.eps
120799

Figure 6-13

By pressing PLAY the user confirms the test, pressing PAUSE will indicate the picture was invisible or incorrect. Pressing NEXT will proceed to the next test

SOUND 1 & SCART DVD TEST

The first soundtest is performed by starting a pink noise sound that needs confirmation from the user (nucleus AudioPinkNoiseOn); the display will show the following message very shortly:

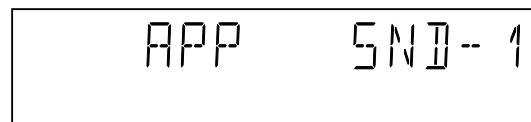

CL 96532065_016.eps
120799

Figure 6-14

This sound will only be audible from version cut3.1 of Sti5505(item7503 on mono board) onwards. After starting up sound 1, SCART loop-trough will be simultaneously active during this test. SCART loop-trough will be measured with the aid of an external video source. When entering the SCART loop-trough, the local display indicates:



CL 96532065_017.eps
120799

Figure 6-15

On the TV screen a colour bar (generated by nucleus VideoCoIDencOn) is visual and the internally generated pinknoise is audible. By pressing PLAY the user confirms the test, pressing PAUSE will indicate the sound was inaudible or incorrect. Pressing NEXT will proceed to the next test; if the user presses NEXT without pressing PLAY or PAUSE first, the result of this test will be TRUE (sound ok). By pressing the NEXT button there will be switched over to the external source, this must become now visible on the TV screen (using the SCART). The local display indicates:



CL 96532065_018.eps
120799

Figure 6-16

The internally generated colour bar is still available on the CVBS and Y/C outputs. And the pinknoise-signal is still available on the cinch audio outputs. By pressing the PREV button, the internal generated colour bar becomes visual again. The test can be left by pressing the NEXT key for more than one second.

SOUND 2 TEST

The second soundtest is performed by producing a sine sound (nucleus AudioSineOn). The signal can be stopped by pressing the STOP-key. The display will show the following message:



CL 96532065_019.eps
120799

Figure 6-17

By pressing PLAY the user confirms the test, pressing PAUSE will indicate that something went wrong. Pressing NEXT will proceed to the next; if the user presses NEXT without pressing PLAY or PAUSE first, the result of this test will be TRUE (sound ok).

Colour set-up test

The colour set-up test is performed by putting the internally generated colour bar in different settings on the TV screen. The first colour bar will be displayed in setting 1. The display will show the following message:



CL96532126_016.eps
261099

Figure 6-18

By pressing the NEXT button, you can go to the second setting. The local display indicates:



CL96532126_017.eps
261099

Figure 6-19

By pressing the PREVIOUS button, the colour bar with the first setting becomes visual again. By pressing PLAY the user confirms the test, pressing PAUSE will indicate that something went wrong. The test can be left by pressing the NEXT key for more than one second; if the user presses NEXT without pressing PLAY or PAUSE first, the result of this test will be TRUE (colour set-up ok).

6.3.3 BASIC ENGINE

VERSION NUMBER

In the basic engine tests, the version number of the Basic Engine will be shown first, as the following example:

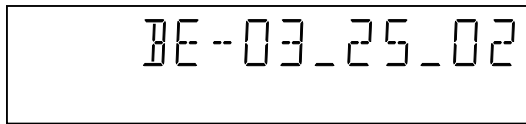

CL 96532126_018.eps
261099

Figure 6-20

By pressing the NEXT key, the Basic Engine tests are started.

TRAY TEST

First, the tray is tested. The purpose of this test is also to give the user the opportunity to put a disc in the tray of the DVD player. Some tests on the Basic Engine require that a disc(e.g. DVD MPTD test disc) is present in the player. At the end of the Basic Engine tests this tray test will be repeated solely to enable the user to remove the disc in the tray. The local display will look as follows:

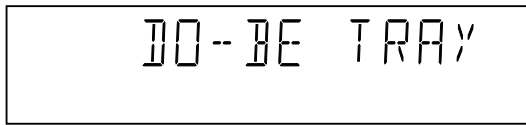

CL 96532065_021.eps
120799

Figure 6-21

By pressing PLAY or PAUSE the user can toggle the position of the tray. Note that this test will not contribute to the test result of the Basic Engine. Pressing NEXT will proceed to the next test, after the tray has been closed (by the software) if it was open.

SLEDGE TEST(visual test)

The second Basic Engine test tests the sledge; the user can move the sledge as many times as desired by using PLAY (nucleus BeSledgeOut) and PAUSE (nucleus BeSledgeIn). Pressing NEXT on the local keyboard proceeds to the next test. Note that this test will not contribute to the test result of the Basic Engine. The local display will look as follows during the sledge test:

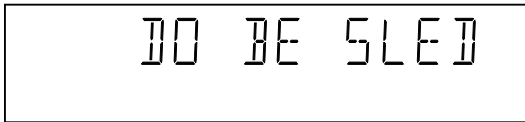

CL 96532065_022.eps
120799

Figure 6-22

DISC MOTOR TEST(visual test)

The third Basic Engine test tests the disc motor (nucleus BeDiscMotorOn); the local display looks as follows:

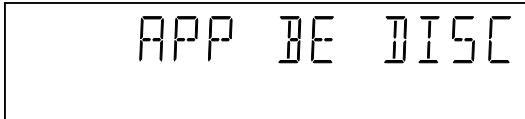

CL 96532065_023.eps
120799

Figure 6-23

By pressing PLAY the user confirms that the disc motor is running; pressing PAUSE indicates the disc motor does not work. Pressing NEXT proceeds to the next test, after a reset of the disc motor (nucleus BeDiscMotorOff). If the user presses NEXT before pressing PLAY or PAUSE, the result of this test will be TRUE (disc motor is running).

FOCUS TEST(visual test)

The fourth Basic Engine test tests the focussing; first focussing is turned on by calling nucleus BeFocusOn. The display will look as follows:

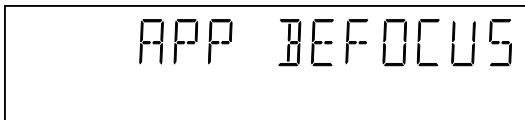

CL 96532065_024.eps
120799

Figure 6-24

By pressing PLAY the user confirms that the focussing was successful; pressing PAUSE indicates a focussing failure. Pressing NEXT proceeds to the next test after a reset of the focussing (nucleus BeFocusOff); if NEXT is pressed before PLAY or PAUSE, the result of this test will be TRUE (focus successful).

RADIAL TEST(visual & listening test)

The fifth Basic Engine test tests the radial functionality (nucleus BeRadialOn); the local display looks as follows:

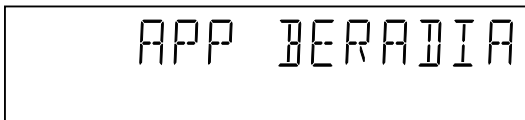

CL 96532065_025.eps
120799

Figure 6-25

By pressing PLAY the user confirms that the radial function worked; pressing PAUSE indicates the function does not work. Pressing NEXT proceeds to the next test, after a reset of the radial (nucleus BeRadialOff). If the user presses NEXT before pressing PLAY or PAUSE, the result of this test will be TRUE (radial successful).

JUMP TEST(listening test)

The sixth and last Basic Engine test tests the jumping by calling nuclei BeGroovesIn, BeGroovesMid and BeGroovesOut. During this test, the local display looks as follows:

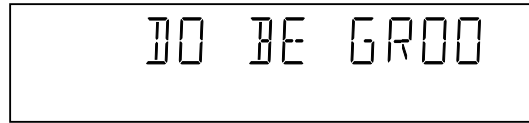

CL 96532065_026.eps
120799

Figure 6-26

The user can switch between the three different types of groove settings by pressing PLAY (forward to next nucleus in the list In-Mid-Out) or PAUSE (backward in the list In-Mid-Out). This is done in a cyclic manner; note that this test will not contribute to the test result of the Basic Engine. Pressing NEXT proceeds to the next test, after the disc motor has been shut off with a call to nucleus BeDiscMotorOff.

TRAY TEST

As a last action for the Basic Engine tests, the tray test is repeated. The local display will look as follows:

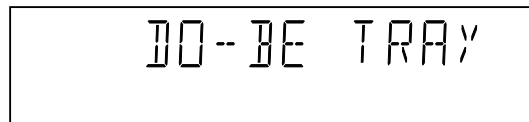

CL 96532065_027.eps
120799

Figure 6-27

This test is meant to give the user the opportunity to remove the disc in the tray. The tray position can be toggled using the PLAY and PAUSE key. The tray will be closed (by the software, if it is open) before proceeding to the next test when the user presses the NEXT key.

ERROR LOG

Reading the error log and error bits information can be useful to determine any errors that occurred recently during normal operation of the DVD player. Reading the error log is done by nucleus LogReadErr. The display during the errorlog readout looks as follows :

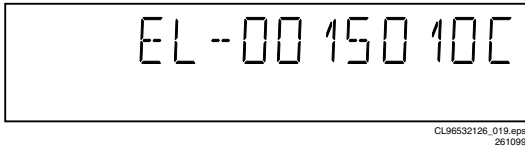

Figure 6-28

By pressing PLAY or PAUSE the user can move forward or backward (respectively) through the logged error codes. The highlighted number indicates which errorcode is currently on display (in the example above, errorcode number 4 is displayed). If "0000" is displayed at all positions, the error log is empty. Display of the logged errors is done in a cyclic manner. The errorcode with the lowest highlighted number is the most

recent. By pressing NEXT on the local keyboard, the user can proceed to the next test.

ERROR BITS

Reading the error bits is done by nucleus LogReadBits. The display during the errorbits readout looks as follows:

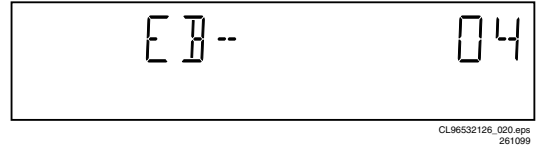

Figure 6-29

Only the set errorbits will be shown by their (decimal) number. Refer to the appropriate documentation for the explanation of each bit number. If the display only shows "EB-0", no error bits were set. By pressing NEXT the user can continue to the next test.

See table below:

Error log / bits table	Read ERROR LOG in player script	Read ERROR BITS in player script
Basic engine errors	Value:	Value:
Command to the Basic Engine not allowed in this state or unknown command	150101	8
Parameter(s) from the command to the Basic Engine is not valid	150102	7
Sledge could not be moved to the inner home position	150103	6
Focus failure	150104	5
Turntable motor could not be reached within timeout	150105	4
Radial servo could get on track on the disc	150106	3
PLL could not lock in the accessing or tracking state	150107	2
Subcode or sector information could not be read	150108	1
requested subcode could not be found	150109	16
Tray could not be closed or opened completely	15010A	15
TOC could not be read within timeout	15010B	14
The requested seek on the disc could not be executed	15010C	13
A requested lead is not on the disc	15010D	12
A non existing burst cutting area is requested	15010E	11
S2b communication error	1501F0	10
S2b communication error	1501F1	9
S2b communication error	1501F3	24
S2b communication error	1501F4	23
S2b communication error	1501F5	22
Digital PWB errors		
Communication error with the Sti 5505	90000	32
Communication error with the Sti 5505	90001	31
Display processor errors		
Communication error with the display processor	190000	40

6.3.4 LOOP TEST

At the start of the loop test, the display will show the result of the interactive player test:

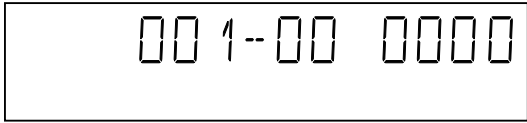

Figure 6-30

The left side of the display contains a 3-digit code, which can have a value between 000 and 111. These values are to be interpreted as follows:

Displayed Value	Indication for each module		
	Basic Engine	Mono PCB	Display PCB
000	ok	ok	ok
001	ok	ok	faulty
010	ok	faulty	ok
011	ok	faulty	faulty
100	faulty	ok	ok
101	faulty	ok	faulty
110	faulty	faulty	ok
111	faulty	faulty	faulty

Figure 6-31

The loop test will perform the same nuclei as the dealer test, but it will loop through the list of nuclei indefinitely. The display of the DVD player will display not only the three digits indicating correct/faulty modules and the last found error code (as mentioned, faults are detected as far as they can be within the scope of the diagnostic software), but also a loop counter indicating how many times the loop has been gone through. Example:

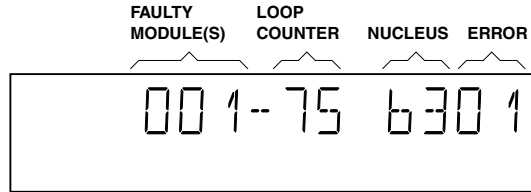

Figure 6-32

The number after the hyphen indicates the number of times the loop test has been performed; the 4 digits at the right side of the display show the last error that was found when running the loop test: the leftmost two digits of this code indicate which nucleus resulted in a fault; the rightmost two digits refer to the faultcode within that nucleus. For further explanation of this error code, see list of error codes below.

ERROR CODES LOOP TEST

ERROR CODE	NUCLEUS NUMBER	ERROR DESCRIPTION
0601	6	Calculated checksum of FLASH is not correct
0901	9	The DVD DRAM is faulty
1101	11	I2C bus busy before start
1102		NVRAM access time-out
1103		No NVRAM Acknowledge
1104		NVRAM reply time-out
1201	12	I2C bus busy
1202		I2C bus not working
1203		Slave controller not responding
1204		Slave response is not correct
1301	13	Parity error from basic engine to serial
1302		Parity error from serial to basic engine
1303		No communication between serial and basic engine
1304		Communication time-out error
1601	16	The SDRAM is faulty
5201	52	I2c bus busy
5202		I2c bus not working
5203		Colour setup controller not responding
5204		Colour setup controller response not correct
5401	54	I2c bus busy
5402		I2c bus not working
5403		Scart switch controller not responding
5404		Scart switch controller response not correct

Figure 6-33

7. Servicing DVD module and MONO board

7.1 Replacing DVD module

The DVD module(Basic Engine and the mono board) has to be exchanged completely in case of failure. A new module for Xemix can be ordered with codenumber 291-90350.969 for Region Code 4 (Australia), 291-90350.970 for Region Code 5 (Russia), and 291-90350.968 for all European countries Region Code 2. A new module for Auro can be ordered with codenumber 291-90350.988 for Region Code 4 (Australia), 291-90350.989 for Region Code 5 (Russia),and 291-90350.987 for all European countries Region Code 2. Return the defective unit complete assembled in original package to Loewe Consumer Service in Kronach.

7.2 Reprogramming of new mono boards.

Caution

This information is confidential and may not be distributed. Only a qualified service person should reprogram the mono board.

After replacement of the mono board, all the customer settings and also the region code will be lost. Reprogramming of the mono board will put the player back in the state in which it has left the factory, i.e. with the default settings and the allowed region code.

Reprogramming is limited to 25 times.
When the counter reaches 25, reprogramming is not possible anymore
Reprogramming will be done by way of the remote control.
Put the player in stop mode, no disc loaded.
Press the following keys on the remote control:
<PLAY> followed by numerical keys <2> <7> <4>
The display shows: "-----"

Press now successively the following keys :

LDV 501L/001 <0><0><1> <0><0><0><0><0><0><0><0><0><0>
LDV 501U/001 <0><0><1> <0><0><0><0><0><0><0><0><0><0>
LDV 502L/001 <0><0><2> <0><0><0><0><0><0><0><0><0><0>
LDV 502U/001 <0><0><2> <0><0><0><0><0><0><0><0><0><0>

Press <PLAY> again.
The TV screen will become BLUE during a short time to confirm that the digital board has been reprogrammed, then the set goes to standby mode.

CL96532158_016.eps
170200

Figure 7-1

7.3 Reset of Virgin Mode

After the player has been powered up for test by the dealer, it would have gone through the Virgin Mode. It is possible to reset the settings made during that mode before the delivery of player to the customer. This can be done as shown in the following diagram:

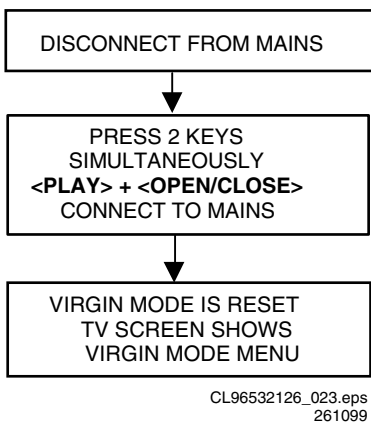

Figure 7-2

TRADE MODE

When the player is in Trade Mode, the player cannot be controlled by means of the front key buttons, but only by means of the remote control.

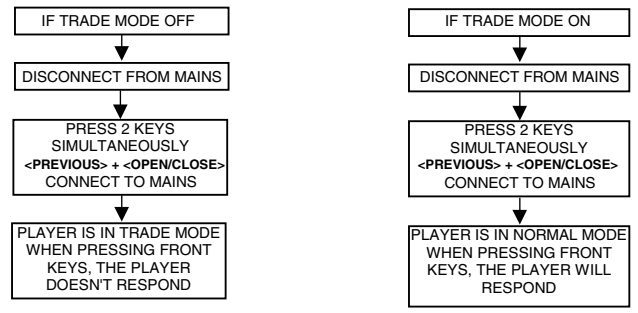

Figure 7-3

8. Test instructions Display board

8.1 Display board

8.1.1 Introduction

These test instructions are written for all versions of the display PCB 396-90348.973.
The contents of the PCB can be split up into next blocks:

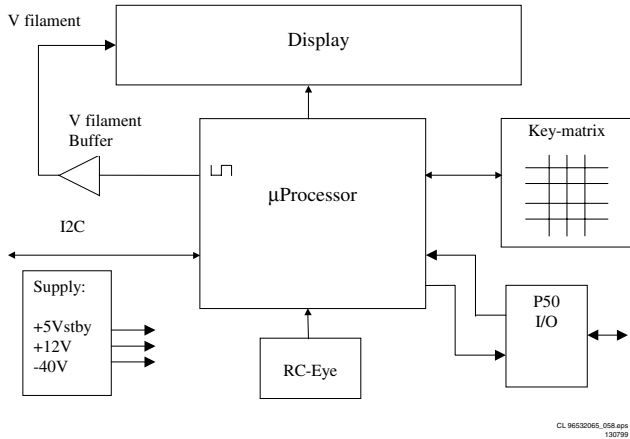

Figure 8-1

8.1.2 Functionality description:

The essential component of the display PCB is the uP (slave). This slave works on an 8MHz resonator and has a reset circuit that is triggered by the +5Vstby. After the reset pulse, the standby control line will release the reset of the host uP. This host uP will then initialise the slave. In addition, when going to stand-by, the slave will put the host uP in reset. When the slave receives the right IR or key code to leave the standby mode, the reset of the host uP will be released.

Other slave functions are:

- Square signal generator to generate the filament voltage, which is required for an AC FTD.
- Generates the grid and segment scanning for the FTD.
- Generates a scanning grid for the keys (separated from display scanning).
- Has inputs for RC (RC5 and RC6) and P50 (P50 controller is built in).

8.1.3 General

- Oscilloscope measurements have been carried out using a Philips PM3392A.
- Impedance of measuring-equipment should be $> 1M\Omega$.
- To do correct measurements we recommend to use supply 396-90350.937, which is used in all "second generation B" DVD-players. Make sure that the main 3.3V has a 0.7A load.

8.1.4 Reset

Check next reset timing with an oscilloscope at pin 10 of the (processor).

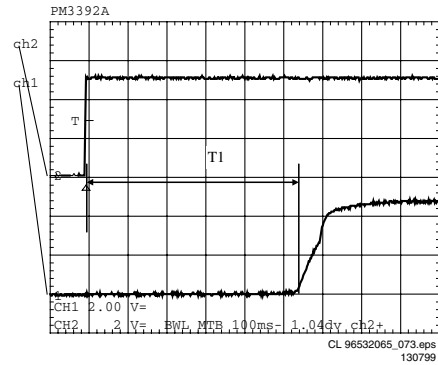

Figure 8-2

Timing: $400\text{msec} < T1 < 700\text{msec}$.
CH1: +5Vstby voltage at power on.
CH2: Voltage at pin 10.

8.1.5 Display steering

Check next timing and level for all grid-lines (G1 r G14).

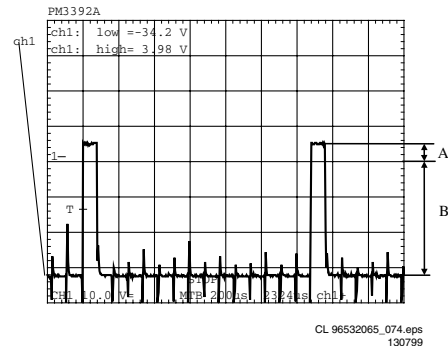

Figure 8-3

1. Check level A: +4V5 (10% for grid lines 1 => 11)
2. Check level A: +4V0 (10% for grid lines 12 => 14)
3. Check level B: -33V (10%)
4. Check timing and levels of segment-lines P1 r P10:

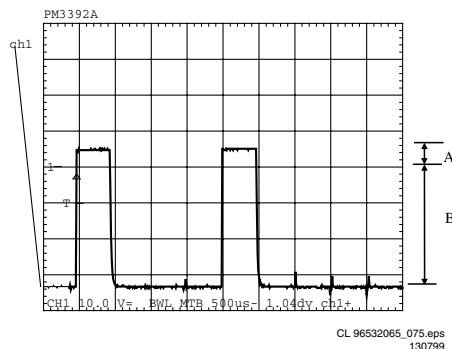

Figure 8-4

Level A: +4V5 (10%)
 Level B: -33V (10%)
 The data on these segment lines depend on the characters that are displayed.
 The characters can be set by sending I2C commands to the display.
 See the Slave URS how to send a display command.

1. Check the voltage at the P50 output connector 1118-5: 4V9 (5%).
2. Check also the uP P50 input (uP pin 20): 5V (5%).
3. Connect the P50 line (connector 1118-5) to ground.
4. Check again the uP P50 input (uP pin 20): <0V3.

8.1.6 Key-matrix

Connect a extra 10k(pull-up to pin 36 en 37 of the (P and check next matrix scanning at these pins.

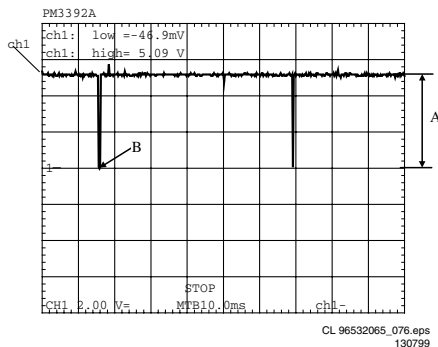

Figure 8-5

Level A: 5.0V (7%)
 Level B: 0V (200mV)
 Check matrix scanning from pin 26 until 33 of the (P.
 The results should be the same as the diagram above.

8.1.7 I.R. receiver

Check at pin 23 of the (P if this line switches from low (< 0.3V) to high (> 4.5V), while pressing a key on a Loewe DVD remote control.

8.1.8 Karaoke interface

The karaoke interface (4 lines) is a single direction communication.
 This means that it consists of four uP output lines.
 The interface can be checked by setting or resetting these output-ports via the I2C bus.
 Send next command via the I2C bus:
 Address : 0x70
 Command byte : 0x24
 Data byte : xxxxabcd
 Wherea : a = Karaoke reset.
 : b = Karaoke data.
 : c = Karaoke clock.
 : d = Karaoke strobe.

8.1.9 P50 interface

P50 is a bi-directional serial interface, which is used for communication between video equipment. For European sets, this communication goes via pin 10 of the scart-bus. In other regions, it can be a cinch bus at the back of the set.

1. Keep the uP in reset by short-circuiting emitter and collector of transistor 7108, via resistor 3100 and 3104 transistor 7101 is switched on.
2. Check the voltage at the P50 output connector 1118-5: < 200mV.

When the reset is released the uP output-pin becomes low and transistor 7101 is switched off.

9. Current mode power supply

9.1 Blockdiagram

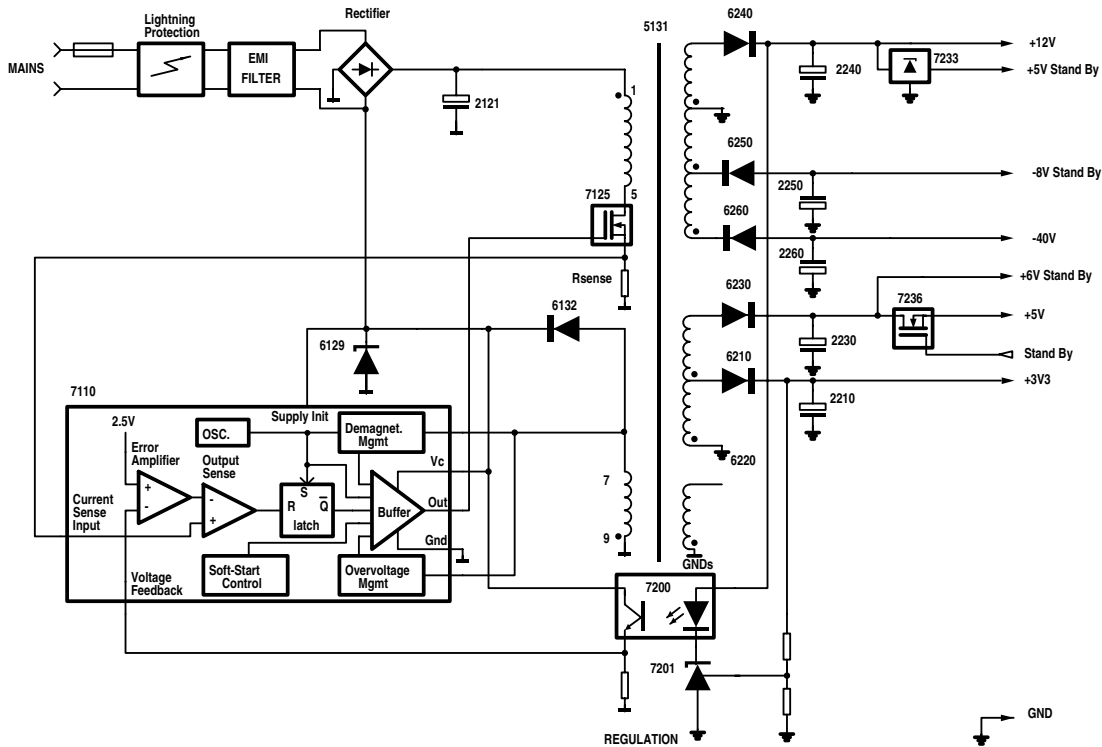

CL 96532065_064.eps
130799

Figure 9-1

9.1.1 Function description of the current mode power supply

MOSFET 7125 is used as a power switch controlled by the controller IC 7110. When the switch is closed, energy is transferred from the mains into the transformer. This energy is then supplied to the load when the switch is opened. By control of the switched-on time, the energy transferred in each cycle is regulated so that the output voltages are independent of load or input voltage variations. The controlling device MC44603P is an integrated pulse width modulator. A clock signal initiates power pulses at a fixed frequency. The termination of each output pulse occurs when an analogue of the inductor current reaches a threshold established by the error signal. In this way the error signal actually controls the peak inductor current on cycle-by-cycle basis.

9.2 General description of MC44603

The MC44603 is an enhanced high performance controller that is specifically designed for Off-line and dc-to dc converter applications. This device has the unique ability of automatically changing operating modes if the converter output is overloaded, unloaded, or shorted. The MC44603 has several distinguishing features when compared to conventional SMPS controllers. These features consist of a foldback facility for overload protection, a standby mode when the converter output is slightly loaded, a demagnetisation detection for reduced switching stresses on transistor and diodes, and a high current totem pole output ideally suited for driving a power MOSFET. It

can also be used for driving a bipolar transistor in low power converters. It is optimised to operate in discontinuous mode but can also operate in continuous mode. Its advanced design allows use in current mode or voltage mode control applications.

9.3 Pin connections

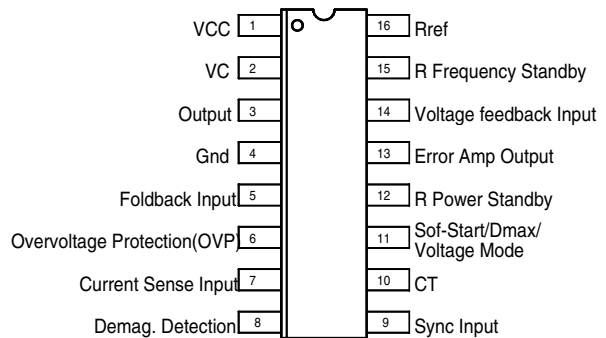

CL 96532065_065.eps
261099

Figure 9-2

9.4 Blockdiagram of MC44603

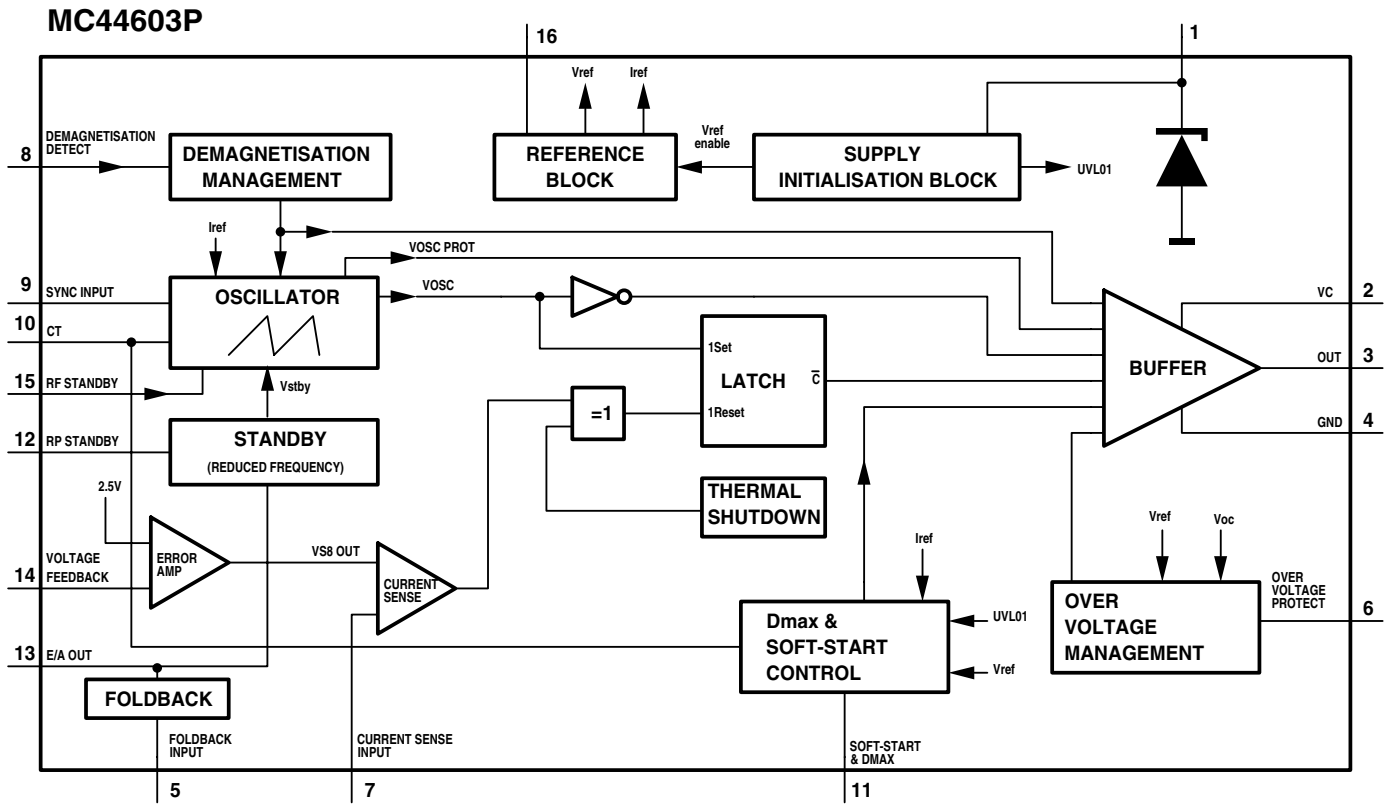

CL 96532065_066.eps
130799

Figure 9-3

9.5 Pin function description

Pin function description

Pin	Name	Description
1	VCC	This pin is the positive supply of the IC. The operating voltage range after start-up is 9.0 to 14.5 V.
2	VC	The output high state (VOH) is set by the voltage applied to this pin.
3	Output	Peak currents up to 750 mA can be sourced or sunk, suitable for driving either MOSFET or Bipolar transistors.
4	Gnd	The groundpin is a single return, typically connected back to the power source.
5	Foldback Input	The foldback function provides overload protection.
6	Overvoltage Protection	When the overvoltage protection pin receives a voltage greater than 2.5V, the device is disabled and requires a complete restart sequence.
7	Current Sense Input	A voltage proportional to the current flowing into the power switch is connected to this input.
8	Demagnetisation Detection	A voltage delivered by an auxiliary transformer winding provides to the demagnetisation pin an indication of the magnetisation state of the flyback transformer. A zero voltage detection corresponds to complete core saturation.
9	Synchronisation Input	The synchronisation input pin can be activated with either a negative pulse going from a level between 0.7V and 3.7V to Gnd or a positive pulse going from a level between 0.7V and 3.7V up to a level higher than 3.7V. The oscillator runs free when Pin 9 is connected to Gnd.
10	C_T	The normal mode oscillator frequency is programmed by the capacitor C_T choice together with the R_{ref} resistance value. C_T , connected between Pin 10 and Gnd, generates the oscillator sawtooth.
11	Soft-Start/Dmax/Voltage-Mode	A capacitor, resistor or a voltage source connected to this pin limits the switching duty-cycle. This pin can be used as a voltage mode control input. By connecting Pin 11 to Ground, the MC44603 can be shut down.
12	RP Standby	A voltage level applied to the RP Standby pin determines the output power level at which the oscillator will turn into the reduced frequency mode of operation (i.e. standby mode). An internal hysteresis comparator allows to return in the normal mode at a higher output power level.
13	E/A Out	The error amplifier output is made available for loop compensation.
14	Voltage Feedback	This is the inverting input of the Error Amplifier. It can be connected to the switching power supply output through an optical (or other) feedback loop.
15	RF Standby	The reduced frequency or standby frequency programming is made by the RF Standby resistance choice.

Figure 9-4

9.6 Operating description

The input voltage V_{cc} (pin 1) is monitored by a comparator with hysteresis, enabling the circuit at 14.5V and disabling the circuit below 7.5V. The error amplifier compares a voltage V_{fb} (pin 14) related to the output voltage of the power supply, with an internal 2.5V reference. The current sense comparator compares the output of the error amplifier with the switch current I_{sense} (pin 7) of the power supply. The output of the current sense comparator resets a latch, which is set every cycle by the oscillator. The output stage is a totem pole, capable of driving a MOSFET directly.

9.6.1 Start-up sequence

t1: Charging the capacitor at V_{cc}

C2129 will be charged via R3123 and R3134, C2133 and C2111 via R3129. The output is switched off during $t1$.

t2: Charging of output capacitors

When the input voltage of the IC exceeds 14.5V, the circuit is enabled and starts to produce output pulses. The current consumption of the circuit increases to about 17mA, depending on the external loads of the IC. At first, the capacitor at the V_{cc} pin will discharge because the primary auxiliary voltage, coming from winding 7-9 is below the V_{cc} voltage. At some moment during $t2$, the primary auxiliary voltage reaches the same level as V_{cc} . The V_{cc} voltage is now determined by this primary auxiliary voltage.

t3: regulation

The output voltage of the power supply is in regulation

t4: overload

When the output is shorted, the supply voltage of the circuit will decrease and after some time drop below the lower threshold voltage. At that moment, the output will be disabled and the process of charging the V_{cc} capacitor starts again. If the output is still shorted at the next $t2$ phase, the complete start-and stop sequence will repeat. The power supply comes in a hiccup mode

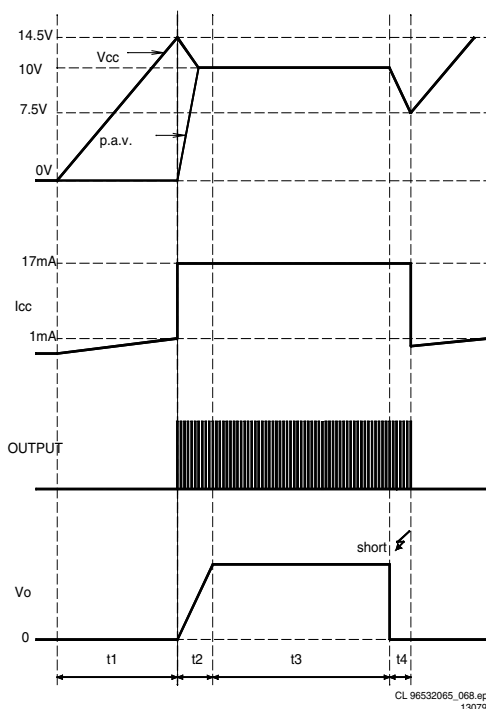

Figure 9-5 Start-up sequence

9.7 Regulation

Figure B shows the most relevant signals during the regulation phase of the power supply.

The oscillator voltage ramps up and down between $V1$ and $V2$. The voltage at the current sense terminal is compared every cycle with the output of the error amplifier V_{comp} . The output is switched off when the current sense level exceeds the level at the output of the error amplifier.

1. TimeON phase : A drain current will flow from the positive supply at pin 1 of the transformer through the transformer's primary winding, the MOSFET and R_{sense} to ground. As the positive voltage at pin 1 of the transformer is constant, the current will increase linearly and create a ramp dependent on the mains voltage and the inductance of the primary winding. A certain amount of energy is stored in the transformer in the form of a magnetic field. The polarity of the voltages at the secondary windings is such that the diodes are non-conducting.
2. TimeDIODE phase : When the MOSFET is switched off, energy is no longer supplied to the transformer. The inductance of the transformer now tries to maintain the current which has been flowing through it at a constant level. The polarity of the voltage from the transformer therefore becomes reversed. This results in a current flow through the transformer's secondary winding via the diodes, electrolytic capacitors and the load. This current is also ramp shaped but decreasing.
3. TimeDEAD phase : when the stored energy has been supplied to the load, the current in the secondary windings stops flowing. At this point the drain voltage of the MOSFET will drop to the voltage of C2121 with a ringing caused by the Drain-Source capacitance with the primary inductance.

The oscillator will start a next cyclus which consists of the described three phases. The time of the different phases depends on the mains voltage and the load.

TimeDEAD is maximum at an input of 400VDC and minimum load, it will be zero at an input of 100VDC and overload.

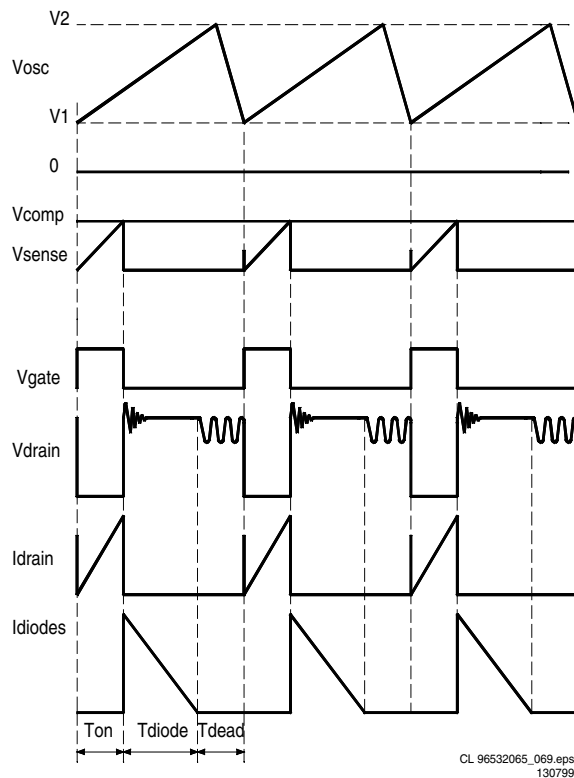
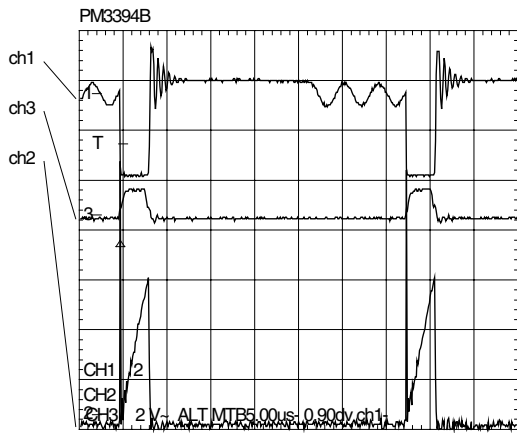
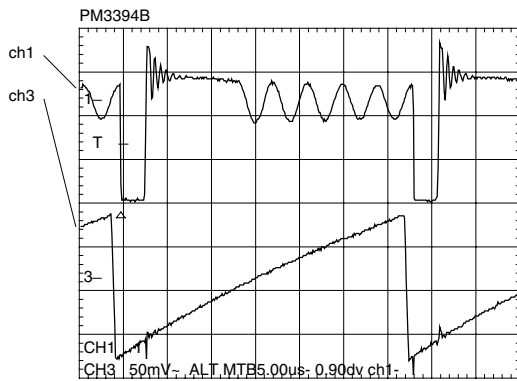

Figure 9-6 Regulation

9.8 Oscillograms



ch1 : Drain voltage
ch2 : Drain current
ch3 : Gate voltage



ch1 : Drain voltage
ch2 : Oscillator voltage

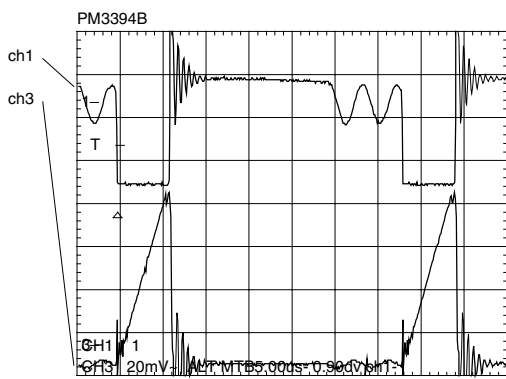

ch1 : Drain voltage
ch3 : Sense voltage

CL 96532065_070.eps
130799

Figure 9-7

9.9 Circuit description

9.9.1 Input circuit

The input circuit consists of a lightning protection circuit and an EMI filter.

The lightning protection comprises R3120, gasarrestor 1125 and R3124. The EMI filter is formed by C2120, L5120, C2125 and C2126. It prevents inflow of noises into the mains.

9.9.2 Primary rectifier/smoothing circuit

The AC input is rectified by rectifier bridge 6120 and smoothed into C2121. The voltage over C2121 is approximately 300V. It can vary from 100V to 390V.

9.9.3 Start circuit and Vcc supply

This circuit is formed by R3123, R3134, C2129, D6129, R3129, R3111, C2133 and C2111.

When the power plug is connected to the mains voltage, the stabilised voltage over D6129(24V) will charge C2133 via R3129. When the voltage reaches 14.5V across C2111, the control circuit of IC7110 is turned on and the regulation starts. During regulation, Vcc of IC7110 will be supplied by the rectified voltage from winding 7-9 via R3135, D6132 and C2133.

9.9.4 Control circuit

The control circuit exists of IC7110, C2102, 2104, 2107, 2109, 2110, R3102, 3103, 3104, 3107, 3108, 3109 and 3110. The frequency of the oscillator is defined by C2102 and R3110.

Power switch circuit

This circuit comprises MOSFET 7125, Rsense 3126, 3127 and 3128, R3125, C2127, L5125, R3112 and R3113. R3125 is a pull-down resistor to remove static charges from the gate of the MOSFET.

9.9.5 Regulation circuit

The regulation circuit comprises opto-coupler 7200 which isolates the error signal from the control IC on the primary side and a reference component 7201. The TL431(7201) can be represented by two components:

- a very stable and accurate reference diode
- a high gain amplifier

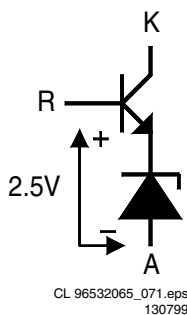

Figure 9-8

TL431 will conduct from cathode to anode when the reference is higher than the internal reference voltage of about 2.5V. If the reference voltage is lower, the cathode current is almost zero. The cathode current flows through the LED of the opto-coupler. The collector current of the opto-coupler flows through R3106, producing an error voltage, connected to voltage feedback pin 14 of IC7110.

9.9.6 Demagnetisation

The auxiliary winding (7-9) voltage is used to detect magnetic saturation of the transformer core and connected via R3101 to pin 8 of IC7110. During the demagnetisation phase, the output will be disabled.

9.9.7 Overvoltage protection circuit

This circuit consist of D6114, C2114, R3115 and R3116. When the regulation circuit is interrupted due to an error in the control loop, the regulated output voltage will increase (overvoltage). This overvoltage is sensed on the primary winding 7-9.

When an overvoltage longer than 2.0 (s) is detected, the output is disabled until VCC is removed and then re-applied. The power supply will come in a hiccup mode as long as the error in the control loop is present.

9.9.8 Secondary rectifier/smoothing circuit

There are 5 rectifier/smoothing circuits on the secondary side. Each voltage depends on the number of windings of the transformer.

The +5Vstby power supply is derived from the +12Vstby by voltage regulator 7233, C2233 and L5233.

The -5V voltage is regulated by voltage regulator 7259 and will be switched off via D6256, T7256 and T7255 during standby (control signal STAND BY is high). When jumper 4250 is mounted instead of this circuit, a supply voltage -8Vstby will be present at pin 9 of connector 0205.

The +5V power supply is derived from +6Vstby by the loader-up circuit formed by MOSFET 7236, reference component 7237, R3236, R3237 and C2239. This voltage will be switched off during STAND BY via T7235.

The 3V3 power supply is regulated by the control loop (7201, 7200, 7110) of the switched mode PSU.

10. List of abbreviations

SIGNAL NAME	DESCRIPTION		
0/6/12	Scart switch control signal A/V board. 0V : loop through (AUX to TV), 6V : play 16:9 format, 12V : play 4:3 format	Y_ENC	Buffered Luma input from DVD monoboard
B	Buffered Video input Blue from DVD monoboard	Y_OUT	Luma output to S-Video output buffer
B/C SWITCHING	Circuit for bi-directional switching of Blue and Chroma on dual scart. Switches between virtual ground (75 ohm) and video output buffer.	YCVBSIN_AUX	Luma or CVBS input from AUX-scart
BC_AUX	Blue or Chroma input from AUX-scart	YCVBSIN_TV	Luma or CVBS input from TV-scart
BC_TV	Blue or Chroma output to TV-scart	YCVBSOUT_AUX	Luma or CVBS output to AUX-scart
BO	Blue output from RGB video processor	YCVBSOUT_TV	Luma or CVBS output to TV-scart
BOUT_TV	Blue output to TV-scart		
C_ENC	Buffered Chroma input from DVD monoboard		
C_OUT	Chroma output to S-Video output buffer		
CENTER	Control signal from monoboard to switch STEREO OUTPUT cinch to mono.		
CVBS	Buffered Composite video input from DVD monoboard		
DC_OFF	Control signal to switch off -8Vstby and +12Vstby during standby		
DIG_OUT	Digital out		
FBIN_AUX	Fast blanking input from AUX-scart		
FBOUT_TV	Fast blanking output to TV-scart		
G	Buffered Video input Green from DVD monoboard		
GIN_AUX	Video input Green from AUX-scart		
GO	Green output from RGB video processor		
GOUT_TV	Video output Green to TV-scart		
HP_L	Headphone left output		
HP_R	Headphone right output		
HSYNC	Horizontal synchronization for RGB video processor.		
KILL	Kill control signal for audio outputs and for soft mute of DAC		
LIN_AUX	Audio input left from AUX-scart		
LIN_TV	Audio input left from TV-scart		
LOUT_AUX	Audio output left to AUX-scart		
LOUT_TV	Audio output left to TV-scart		
LRCLK	Left/Right clock		
P50	Bi-directional interface used for communication between video equipment		
PCM_CLK	Audio system clock for DAC		
PCM_OUT[0:2]	Audio serial output data		
R	Buffered Video input Red from DVD monoboard		
RCIN_TV	Red or Chroma input from TV-scart		
RCOUT_TV	Red or Chroma output to TV-scart		
RIN_AUX	Audio input right from AUX-scart		
RIN_TV	Audio input right from TV-scart		
RO	Red output from RGB video processor		
ROUT_AUX	Audio output right to AUX-scart		
ROUT_TV	Audio output right to TV-scart		
SCL	I2C bus clock		
SCLK	Audio serial bit clock		
SDA	I2C bus data		
ST_L	Stereo left output (not used)		
ST_R	Stereo right output (not used)		
STEREO_L	Audio cinch output left		
STEREO_MUTE	Control signal from monoboard to switch on stereo mute circuit (option)		
STEREO_R	Audio cinch output right		

11. IC-descriptions



STV6410

AUDIO/VIDEO SWITCH MATRIX

- I²C BUS CONTROL
- STANDBY MODE

VIDEO SECTION

- 5 CVBS INPUTS, 4 CVBS OUTPUTS (ONE WITH SELECTABLE CHROMA TRAP FILTER)
- 5 Y/C INPUTS, 3 Y/C OUTPUTS
- 6dB GAIN ON ALL CVBS/Y AND C OUTPUTS
- 1 Y/C ADDER
- 2 RGB/FB INPUTS, 1 RGB/FB OUTPUT WITH 6dB ADJUSTABLE GAIN
- VIDEO MUTING ON ALL THE OUTPUTS
- 3 SLOW BLANKING INPUTS/OUTPUTS
- SYNC BOTTOM CLAMP ON ALL CVBS/Y AND RGB INPUTS, AVERAGE ON C INPUTS
- BANDWIDTH : 15MHz
- CROSSTALK : 60dB Typ.

AUDIO SECTION

- 5 STEREO INPUTS, 4 STEREO OUTPUTS (TWO WITH LEVEL ADJUSTMENT)
- MONO SOUND OUTPUT
- MONO SOUND CAPABILITY ON TV OUTPUTS
- AUDIO MUTING ON ALL THE OUTPUTS

DESCRIPTION

The STV6410 is a highly integrated I²C bus-controlled audio and video switch matrix, optimized for use in digital set-top box applications. It provides all the audio and video routings required in a full three scart set-top box design. It is also fully pin compatible with STV6411, the two scart version.

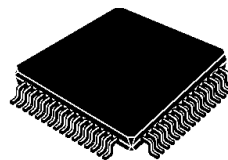

TQFP64
(Plastic Quad Flat Pack)

ORDER CODE : STV6410D

PIN CONNECTIONS

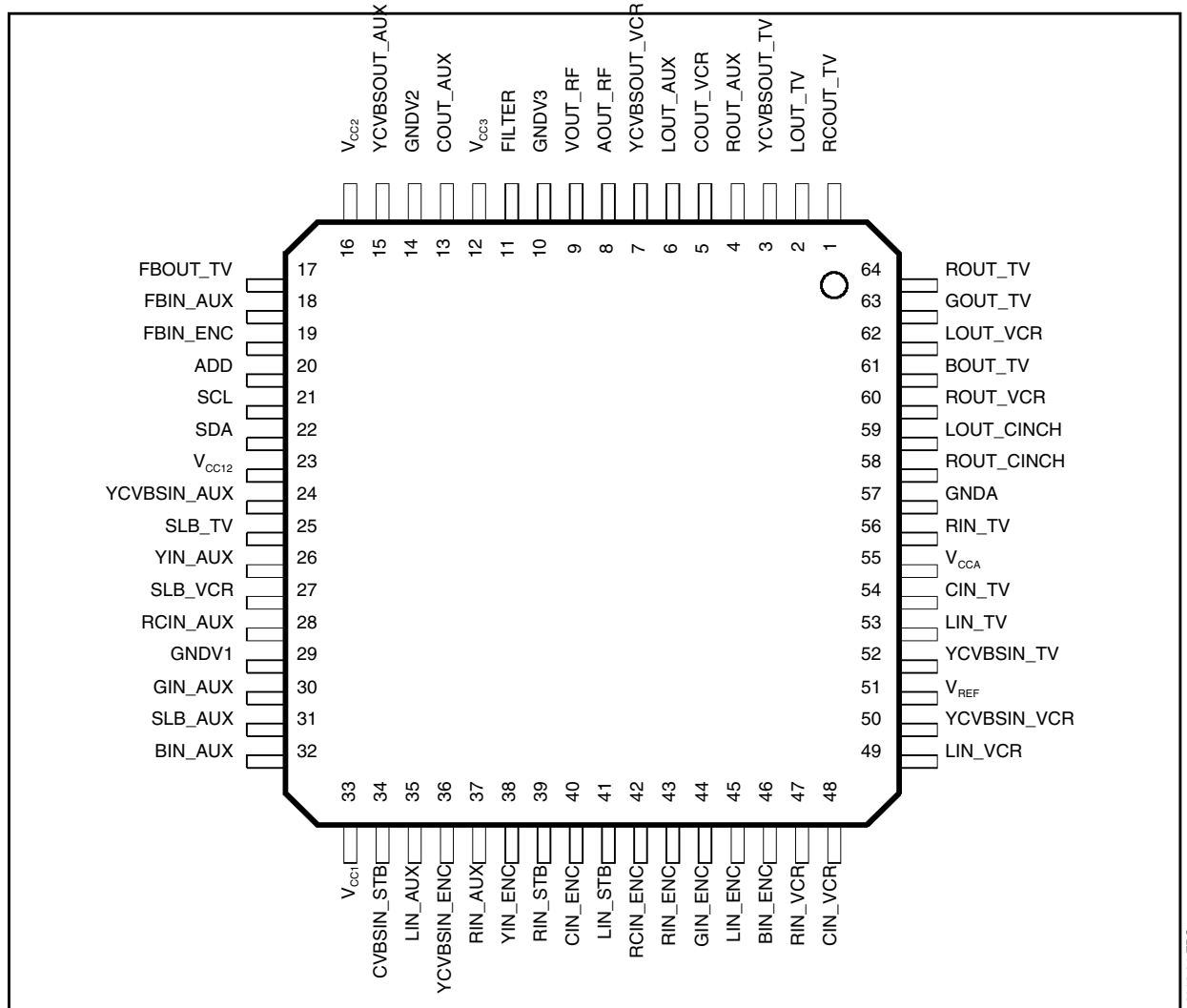

6410-01.EPS

PIN LIST

Pin Number	Symbol	Description
1	RCOUT_TV	Red/chroma Output, to TV Scart
2	LOUT_TV	Audio Left Output, to TV Scart
3	YCVBSOUT_TV	Y/CVBS Output, to TV scart
4	ROUT_AUX	Audio Right Output, to AUX Scart
5	COUT_VCR	Chroma Output, to VCR Scart
6	LOUT_AUX	Audio Left Output, to AUX Scart
7	YCVBSOUT_VCR	Y/CVBS Output, to VCR Scart
8	AOUT_RF	Audio (L+R) Output to RF Modulator
9	VOUT_RF	Video (CVBS) Output to RF Modulator
10	GNDV3	Video Switches Ground 3
11	FILTER	Chroma Trap Filter
12	V _{CCV3}	Video Switches Supply 3 (8V)
13	COUT_AUX	Chroma Output, to AUX Scart
14	GNDV2	Video Switches Ground 2
15	YCVBSOUT_AUX	Y/CVBS Output, to AUX Scart

6410-01.TBL

PIN LIST (continued)

Pin Number	Symbol	Description
16	V _{ccv2}	Video Switches Supply 2 (8V)
17	FBOU _{TV}	Fast Blanking Output, to TV Scart
18	FBIN _{AUX}	Fast Blanking Input, from AUX Scart
19	FBIN _{ENC}	Fast Blanking Input, from Encoder
20	ADD	I ₂ C Bus IC Address Programmation
21	SCL	I ₂ C Bus Clock
22	SDA	I ₂ C Bus Data
23	V _{cc12}	Slow Blanking Power Supply (12V)
24	YCVBSIN _{AUX}	Y/CVBS Input from AUX Scart
25	SLB _{TV}	Slow Blanking Input/Output from TV
26	YIN _{AUX}	Y Input, from AUX Scart
27	SLB _{VCR}	Slow Blanking Input/Output from VCR
28	RCIN _{AUX}	Red/Chroma Input, from AUX Scart
29	GNDV1	Video Switches Ground 1
30	GIN _{AUX}	Green Input, from AUX Scart
31	SLB _{AUX}	Slow Blanking Input/Output from AUX
32	BIN _{AUX}	Blue Input, from AUX Scart
33	V _{ccv1}	Video Switches Supply 1 (8V)
34	CVBSIN _{STB}	CVBS Input from STB
35	LIN _{AUX}	Audio Left Input, from AUX Scart
36	YCVBSIN _{ENC}	Y/CVBS Input from Encoder
37	RIN _{AUX}	Audio Right Input, from AUX Scart
38	YIN _{ENC}	Y Input, from Encoder
39	RIN _{STB}	Audio Right Input, from STB
40	CIN _{ENC}	Chroma Input, from Encoder
41	LIN _{STB}	Audio Left Input, from STB
42	RCIN _{ENC}	Red/Chroma Input, from Encoder
43	RIN _{ENC}	Audio Right Input, from Encoder
44	GIN _{ENC}	Green Input, from Encoder
45	LIN _{ENC}	Audio Left Input, from Encoder
46	BIN _{ENC}	Blue Input, from Encoder
47	RIN _{VCR}	Audio Right Input, from VCR Scart
48	CIN _{VCR}	Chroma Input, from VCR Scart
49	LIN _{VCR}	Audio Left Input, from VCR
50	YCVBSIN _{VCR}	Y/CVBS Input from VCR Scart
51	V _{REF}	Voltage Reference Decoupling
52	YCVBSIN _{TV}	Y/CVBS Input, from TV Scart
53	LIN _{TV}	Audio Left Input, from TV Scart
54	CIN _{TV}	Chroma Input, from TV Scart
55	V _{CCA}	Audio Switches Supply (8V)
56	RIN _{TV}	Audio right input, from TV Scart
57	GND _A	Audio Switches Ground
58	ROUT _{CINCH}	Audio Right Output, to CINCH
59	LOUT _{CINCH}	Audio Left Output, to CINCH
60	ROUT _{VCR}	Audio Right Output, to VCR sCart
61	BOUT _{TV}	Blue Output, to TV Scart
62	LOUT _{VCR}	Audio Left Output, to VCR Scart
63	GOUT _{TV}	Green Output, to TV Scart
64	ROUT _{TV}	Audio Right Output, to TV Scart

6410-01.TBL

BLOCK DIAGRAM

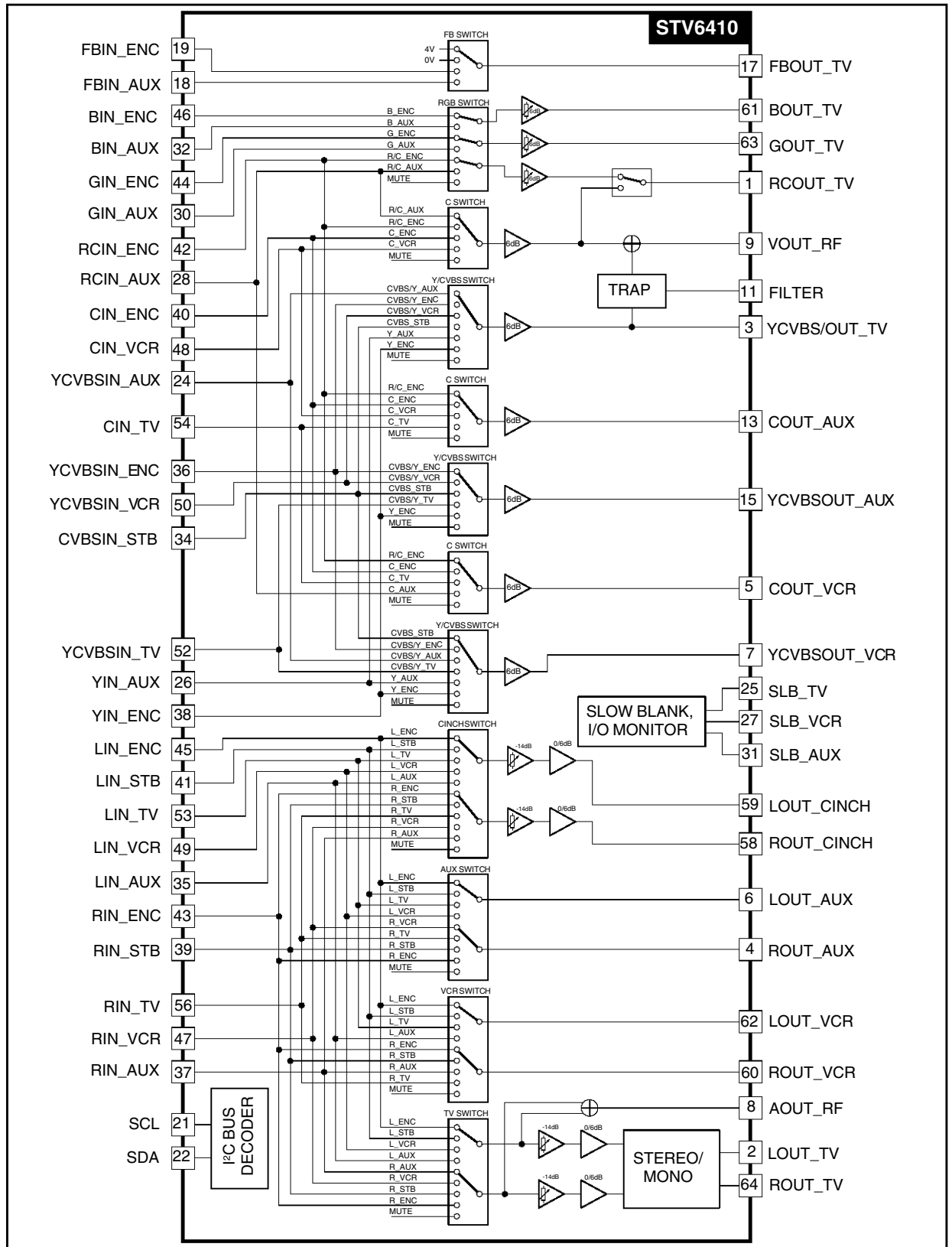

641002.EPS

RGB video processor with automatic cut-off control and gamma adjust

TDA4780

FEATURES

- Gamma adjust
- Dynamic black control (adaptive black)
- All input signals clamped on black-levels
- Automatic cut-off control, alternative: output clamping on fixed levels
- Three adjustable reference voltage levels via I²C-bus for automatic cut-off control
- Luminance/colour difference interface
- Two luminance input levels allowed
- Two RGB interfaces controlled by either fast switches or by I²C-bus
- Two peak drive limiters, selection via I²C-bus
- Blue stretch, selection via I²C-bus
- Luminance output for scan velocity modulation (SCAVEM)
- Extra luminance output; same pin can be used as hue control output e.g. for the TDA4650 and TDA4655
- Non standard operations like 50 Hz/32 kHz are also possible
- Either 2 or 3 level sandcastle pulse applicable
- High bandwidth for 32 kHz application
- White point adjusts via I²C-bus
- Average beam current and improved peak drive limiting
- Two switch-on delays to prevent discoloration during start-up
- All functions and features programmable via I²C-bus
- PAL/SECAM or NTSC matrix selection.

GENERAL DESCRIPTION

The TDA4780 is a monolithic integrated circuit with a luminance and a colour difference interface for video processing in TV receivers. Its primary function is to process the luminance and colour difference signals from a colour decoder which is equipped e.g. with the multistandard decoder TDA4655 or TDA9160 plus delay line TDA4661 or TDA4665 and the Picture Signal Improvement (PSI) IC TDA467X or from a feature module.



The required input signals are:

- Luminance and negative colour difference signals
- 2 or 3-level sandcastle pulse for internal timing pulse generation
- I²C-bus data and clock signals.

Two sets of analog RGB colour signals can also be inserted, e.g. one from a peritelevision connector (SCART plug) and the other one from an On-Screen Display (OSD) generator. The TDA4780 has I²C-bus control of all parameters and functions with automatic cut-off control of the picture tube cathode currents. It provides RGB output signals for the video output stages. In clamped output mode it can also be used as an RGB source.

The main differences with the sister type TDA4680 are:

- Additional features, namely gamma adjust, adaptive black, blue stretch and two different peak drive limiters
- The measurement lines are triggered by the trailing edge of the vertical component of the sandcastle pulse
- I²C-bus receiver only. Automatic white level control is not provided; the white levels are determined directly by the I²C-bus data.
- The TDA4780 is pin compatible (except pin 18) with the TDA4680. The I²C-bus slave address can be used for both ICs. When a function of the TDA4780 is not included in the TDA4680, the I²C-bus command is not executed. Special commands (except control bit FSWL) for the TDA4680 will be ignored by the TDA4780.

RGB video processor with automatic cut-off control and gamma adjust

TDA4780

BLOCK DIAGRAM

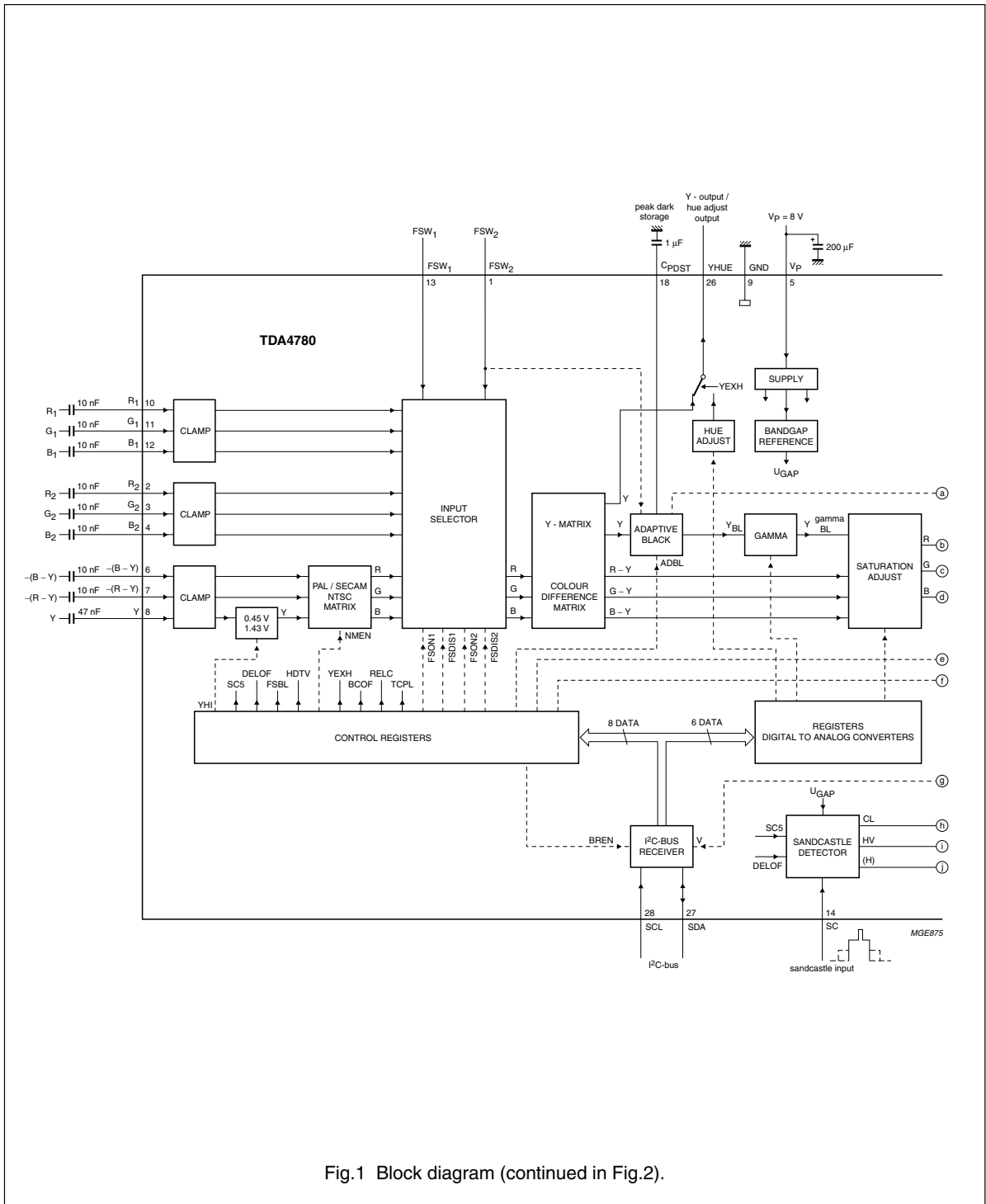

Fig.1 Block diagram (continued in Fig.2).

RGB video processor with automatic cut-off control and gamma adjust

TDA4780

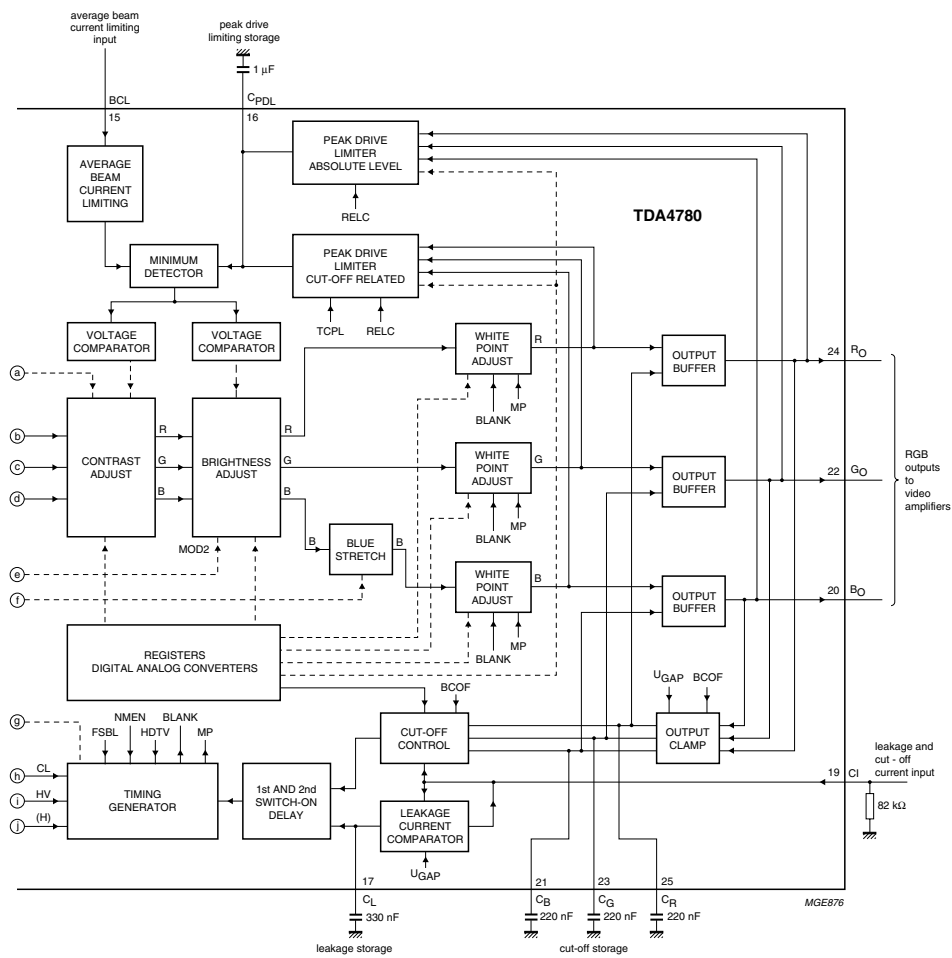

Fig.2 Block diagram (continued from Fig.1).

 RGB video processor with automatic
cut-off control and gamma adjust

TDA4780

PINNING

SYMBOL	PIN	DESCRIPTION
FSW2	1	Fast switch 2 input
R2	2	Red input 2
G2	3	Green input 2
B2	4	Blue input 2
VP	5	Supply voltage
-(B – Y)	6	Colour difference input –(B – Y)
-(R – Y)	7	Colour difference input –(R – Y)
Y	8	Luminance input
GND	9	Ground
R1	10	Red input 1
G1	11	Green input 1
B1	12	Blue input 1
FSW1	13	Fast switch 1 input
SC	14	Sandcastle pulse input
BCL	15	Average beam current limiting input
CPDL	16	Storage capacitor for peak limiting
CL	17	Storage capacitor for leakage current compensation
CPDST	18	Storage capacitor for peak dark
CI	19	Cut-off measurement input
BO	20	Blue output
CB	21	Blue cut-off storage capacitor
GO	22	Green output
CG	23	Green cut-off storage capacitor
RO	24	Red output
CR	25	Red cut-off storage capacitor
YHUE	26	Y-output/hue adjust output
SDA	27	I2C-bus serial data input/acknowledge output
SCL	28	I2C-bus serial clock input

RGB video processor with automatic cut-off control and gamma adjust

TDA4780

FUNCTIONAL DESCRIPTION

Signal input stages

The TDA4780 contains 3 sets of input signal stages for:

1. Luminance/colour-difference signals:
 - a) Y: 0.45 V (p-p) VBS or 1.43 V (p-p) VBS, selectable via I²C-bus.
 - b) $-(R - Y)$: 1.05 V (p-p).
 - c) $-(B - Y)$: 1.33 V (p-p).

The capacitively coupled signals are matrixed to RGB signals by either a PAL/SECAM or NTSC matrix (selected via I²C-bus).

2. (RGB)₁ signals (0.7 V (p-p) VB), capacitively coupled (e.g. from external source).
3. (RGB)₂ signals (0.7 V (p-p) VB), capacitively coupled (e.g. videotext, OSD).

All input signals are clamped in order to have the same black levels at the signal switch input. Displayed signals must be synchronous with the sandcastle pulse.

Signal switches

Both fast signal switches can be operated by switching pins (e.g. SCART facilities) or set via the I²C-bus. With the pin FSW₁ the Y-CD signals or the (RGB)₁ signals can be selected, with pin FSW₂ the above selected signals or the (RGB)₂ signals are enabled. During the vertical and horizontal blanking time an artificial black level equal to the clamped black level is inserted in order to clip off the sync pulse of the luminance signal and to suppress hum during the cut-off measurement time and eliminate noise during these intervals.

Saturation, contrast and brightness adjust

Saturation, contrast and brightness adjusts are controlled via the I²C-bus and act on Y, CD as well as on RGB input signals. Gamma acts on the luminance content of the input signals.

Gamma adjust

The gamma adjust stage has a non-linear transmission characteristic according to the formula $y = x^{\text{gamma}}$, where x represents the input and y the output signal. If gamma is smaller than unity, the lower parts of the signal are amplified with higher gain.

Adaptive black (ADBL)

The adaptive black stage detects the lowest voltage of the luminance component of the internal RGB signals during the scanning time and shifts it to the nominal black level. In order to keep the nominal white level the contrast is increased simultaneously.

Blue stretch (BLST)

The blue stretch channel gets additional amplification if the blue signal is greater than 80% of the nominal signal amplitude. In the event the white point is shifted towards higher colour temperature so that white parts of a picture seem to be brighter.

Measurement pulse and blanking stage

During the vertical and horizontal blanking time and the measurement period the signals are blanked to an ultra black level, so the leakage current of the picture tube can be measured and automatically compensated for.

During the cut-off measurement lines (one line period for each R, G or B) the output signal levels are at cut-off measurement level.

The vertical blanking period is timed by the sandcastle pulse. The measurement pulses (leakage, R, G and B) are triggered by the negative going edge of the vertical pulse of the sandcastle pulse and start after the following horizontal pulse.

The IC is prepared for $2f_H$ (32 kHz) application.

Output amplifier and white adjust potentiometer

The RGB signals are amplified to nominal 2 V (p-p), the DC-levels are shifted according to cut-off control. The nominal signal amplitude can be varied by $\pm 50\%$ by the white point adjustment via the I²C-bus (individually for RGB respect).

RGB video processor with automatic cut-off control and gamma adjust

TDA4780

Automatic cut-off control

During leakage measurement time the leakage current is compensated in order to get a reference voltage at the cut-off measurement info pin. This compensation value is stored in an external capacitor. During cut-off current measurement times for the R, G and B channels, the voltage at this pin is compared with the reference voltage, which is individually adjustable via I²C-bus for each colour channel. The control voltages that are derived in this way are stored in the external feedback capacitors. Shift stages add these voltages to the corresponding output signals. The automatic cut-off control may be disabled via the I²C-bus. In this mode the output voltage is clamped to 2.5 V. Clamping periods are the same as the cut-off measurement periods.

Signal limiting

The TDA4780 provides two kinds of signal limiting. First, an average beam limiting, that reduces signal level if a certain average is exceeded. Second, a peak drive limiting, that is activated if one of the RGB signals even shortly exceeds a via I²C-bus adjusted threshold. The latter can be either referred to the cut-off measurement level of the outputs or to ground.

When signal limiting occurs, contrast is reduced, and at minimum contrast brightness is reduced additionally.

Sandcastle decoder and timer

A 3-level detector separates the sandcastle pulse into combined line and field pulses, line pulses, and clamping pulses. The timer contains a line counter and controls the cut-off control measurement.

Application with a 2-level 5 V sandcastle pulse is possible.

Switch on delay circuit

After switch on all signals are blanked and a warm up test pulse is fed to the outputs during the cut-off measurement lines. If the voltage at the cut-off measurement input exceeds an internal level the cut-off control is enabled but the signal remains still blanked. In the event of output clamping, the cut-off control is disabled and the switch on procedure will be skipped.

Y output and hue adjust

The TDA4780 contains a D/A converter for hue adjust. The analog information can be fed, e.g. to the multistandard decoder TDA4650 or TDA4655. This output pin may be switched to a Y output signal, which can be used for scan velocity modulation (SCAVEM). The Y output is the Y input signal or the matrixed (RGB) input signal according to the switch position of the fast switch.

I²C-bus

The TDA4780 contains an I²C-bus receiver for control function.

ESD protection

The Pins are provided with protection diodes against ground and supply voltage (see Chapter "Internal pin configurations"). I²C-bus input pins do not shunt the I²C-bus signals in the event of missing supply voltage.

EMC

The pins are protected against electromagnetic radiation.

Loewe Service Europa • Europe

Benelux

Loewe Opta Benelux NV/SA
LuitenantLippenslaan 54 B
B-2140 Antwerpen
Tel. 0902-88002
Fax 03-2354837

Loewe Opta Nederland B.V.
Ravenswade 54A1
NL-3439 LD Nieuwegein (Utrecht)
Tel. 030-803773
Fax 030-803327

Dänemark

Semi-Tech Consumer Electronics (Denmark)
AS
Hørskættens 3
DK-2630 Taastrup
Tel. 43597777
Fax 43597700

Deutschland

LOEWE OPTA GmbH
Service und Logistik / Zentrale Kronach
96305 Kronach • Postfach 1554
96317 Kronach • Industriestrasse 11
Tel. 0180-5221800
Fax 0180-5221806
DxJ-Tln.-Nr. 0926199
Internet: <http://www.loewe.de>

Frankreich

Sorep Import S.A. Loewe Opta
11 Rue de la Durance
BP 954
F-67029 Strasbourg Cédex 1
Tel. 3-88797250
Fax 3-88797259

Griechenland

SOUNDHELLASSA.
Kleanthous Str. 10
GR-54642 Thessaloniki
Tel. 0030-31-856100
Fax 0030-31-856300

Grossbritannien

Linn Products Limited
Floors Road, Waterfoot,
Eaglesham,
Glasgow G76 0EP
Tel. 0141-3077777
Fax 0141-6444262

GLS

Service Center Loewe
ul. Verkhnyaya Maslovka, d. 29
RUS-125083 Moscow
Tel. 095-2125043, 9566764
Fax 095-2124710

Italien

General Trading Trust SpA
Via Volturmo 10/12 - Scala B
I-50019 Sesto Fiorentino (FI)
Tel. 055-300342
Fax 055-300343

Malta

Mirage Holdings LTD
Flamingo Complex
Cannon Road
M-Qormi
Tel. 497182
Fax 445983

Norwegen

CableCom AS
Bekkevn, 9
N-3218 Sandefjord
Tel. 033/483348
Fax 033/483333

Österreich

Robert Bosch AG
Postfach 146
A-1011 Wien
Tel. 01-797224500
Fax 01-797224599

Pimgruber
Elektronik Service & Vertriebsges. m.b.H.
Dauphinestr. 226
A-4030 Linz
Tel. 0732/387282-0
Fax 0732/387282-0

Polen

PPHUPAROSSp.zo.o.
ul. Ustronie 1-3
PL-50-302 Wrocław
Tel. 071-3222014, 3222017
Fax 071-3221061

Portugal

Videoacustica
Comercio e Representacoes de
Equipamentos Electronicos S.A.
Estrada Circunvalacao
Apartado 3127
P-1301-902 Lisboa Codex
Tel. 01-4170004
Fax 01-4188093

Schweden

Elektronikservice i GBG AB
Frickullagatan 23
S-41262 Göteborg
Tel. 031-811486
Fax 031-812770

Schweiz

Tellon AG
Rütistrasse 26
CH-8952 Schlieren
Tel. 01-7321511
Fax 01-7301502

Slowenien

Jadran Export Import D.D.
Partizanska cesta 69
SL-6210 Sezana
Tel. 067-391402, 391406
Fax 067-391400

Spanien & Kanarische Inseln

Gaplasa S.A.
Conde de Torroja, 25
E-28022 Madrid
Tel. 01-7482960
Fax 01-3291675

Tschechische Republik

Tipa Spol. SR. O.
Dolní náměstí 9
CZ-74601 Opava
Tel. 0653-624404
Fax 0653-623147

Ungarn

Annex
Kereskedelmi Részvénytársaság
H-1119 Budapest, Fehérvári út. 44
Tel. 01-2066000
Fax 01-3826040

Zypern

Pangratis Liveras & Son LTD
Liveras Building
7 Ajax Street
Saint Omologite
CY-Nicosia
Tel. 02-663496
Fax 02-664212, 667936

Loewe Service Übersee • Overseas

Australien

International Dynamics
RIFLTD
(Wholesale) PTY LTD
78-80 Herald Street
AUS-Cheltenham, Victoria 3192
Tel. 03-95850522
Fax 03-95850179

Israel

RIFLTD
29, Izhak Sade Street
IRS - Tel Aviv 67213
Tel. 03-6240555
Fax 03-6240303

Ver. Arabische Emirate

Super Trading Establishment
P.O. Box 46409
Abu Dhabi, United Arab Emirates
Tel. 02-748787
Fax 02-741156

USA

SENSORYS SCIENCE CORP.
7835 East McClain Drive,
Scottsdale,
Arizona
USA 85260-1732
Tel. 602-9983400
Fax 602-9514404

Änderungen vorbehalten
Subject to modification

Loewe-Vertragswerkstätten • Loewe establishments

Berlin

VHF Fernsehendienst GmbH
Ulrich Capito
Ebersstraße 78
10827 Berlin/Schöneberg
Tel. 030/2133006
Fax 030/2133007

Hamburg

Michael Hinz
Audio-Video-TV-Service
Antonie-Möbis-Weg 5
22523 Hamburg
Tel. 040/5708010
Fax 040/5708017

Niedersachsen

Video Electronic Service
Inh. Gerhard Will
Uhlenhort 81a
21435 Stelle
Tel. 04174/71880
Fax 04174/718824

Niedersachsen

Wolfgang Schütte GmbH
TV-HiFi-Meisterwerkstatt
Bernhardstr. 36
26122 Oldenburg
Tel. 0441/502035
Fax 0441/508487

Niedersachsen

DW-Service GmbH
Haltenhoffstraße 52-54
30167 Hannover
Tel. 0511/714073
Fax 0511/7000997

Nordrhein-Westfalen

TSW-Techn. Service Wenzel
Klingenbergerstraße 38-40
32756 Detmold
Tel. 05231/39513
Fax 05231/39613

Nordrhein-Westfalen

Jürgen Wolber
Electronic-Service
Weißenburgerstraße 52
40476 Düsseldorf
Tel. 0211/443456
Fax 0211/464433

Nordrhein-Westfalen

HVSLösbar GmbH
Hauert 16
44227 Dortmund
Tel. 0231/9753333
Fax 0231/97533350

Nordrhein-Westfalen

EWS Elektronik-Service
Dipl.-Ing. Fred Wenzel
Auf der Jüchen 2
51069 Köln
Tel. 0221/6801585
Fax 0221/6801588

Rheinland-Pfalz

Hans Krempf/Haustechnik GmbH
August-Horch-Straße 14
56070 Koblenz
Tel. 0261/8909-0
Fax 0261/83074

Hessen

VAD Video- und Audio-Dienst
Ostring 7
65205 Wiesbaden-Nordenstadt
Tel. 06122/909180
Fax 06122/909150

Hessen

Femseh-Kessler
Veckerhagener Straße 58
34233 Fuldatal
Tel. 0561/813001, 813002, 813003
Fax 0561/819185

Baden-Württemberg

AVS-Zerweck GmbH
Heppenheimer Straße 31-33
68309 Mannheim
Tel. 0621/7280611
Fax 0621/7280610

Baden-Württemberg

AV-Technik Wagner Zerweck GmbH
Schulze-Delitzsch-Straße 16
70565 Stuttgart
Tel. 07111/7800423
Fax 07111/7800426

Baden-Württemberg

Pavlek Service-Center
Rilkestraße 5
71229 Leonberg
Tel. 07152/905116, 905117
Fax 07152/905118

Baden-Württemberg

Autronic Electronic-Service GmbH
Greschbachstraße 29
76229 Karlsruhe
Tel. 0721/6299128
Fax 0721/6299195

Baden-Württemberg

CES Consumer-Electronic-Service GmbH
Königsberger Straße 12
78628 Rottweil
Tel. 0741/2490
Fax 0741/249274

Bayern

Jürgen Drössler
Fernseh-Video-Service
Lerchenstraße 8
80995 München
Tel. 089/35716831
Fax 089/35716838

Bayern

Norbert Nickl
Kopernikusstraße 21/23
90459 Nürnberg
Tel. 0911/4466460
Fax 0911/4466414

Mecklenburg

Wolfgang Schubert
Lange Reihe 38b
17121 Loitz
Tel. 039998/10577
Fax 039998/10566

Mecklenburg

Wilhelm Meissner GmbH
Dorfstraße 1
18107 Lichtenhagen-Dorf
Tel. 038209/81950
Fax 038209/81951

Mecklenburg

Service-Center Baumeister
Neue Reuhe 14
18190 Sanitz
Tel. 0381/7600062
Fax 0381/7600063

Brandenburg

Ihlefeldt Sehen und Hören
Berliner Str. 8
14532 Güterfelde
Tel. 03329/62192
Fax 03329/62296

Sachsen-Anhalt

Schwanbeck & Gall GmbH
Weißenfelser Straße 1
06712 Zeitz
Tel. 03441/86210
Fax 03441/86211

Sachsen-Anhalt

Service-Partner Völkel
Camotstraße 27
39120 Magdeburg
Tel. 0391/628777
Fax 0391/6287719

Sachsen

GKK Elektronik Service GmbH
Hoimühlenstraße 25
01187 Dresden
Tel. 0351/4213424
Fax 0351/4226826

Sachsen

HVSLösbar GmbH
Landsberger Straße 23
04157 Leipzig
Tel. 0341/9126070
Fax 0341/9126071

Sachsen

Semmler GmbH
Schulstraße 36
09337 Hohenstein-Ernstthal
Tel. 03723/65200
Fax 03723/652028

Thüringen

Audio-Video-Elektrik
Service GmbH
Lange Brücke 35
99084 Erfurt
Tel. 0361/5626285
Fax 0361/6430871

Thüringen

Gärtner-Elektronik-GmbH & Co.KG
Saalbahnstraße 21
07743 Jena
Tel. 03641/40840
Fax 03641/408429

Die wichtigsten Rufnummern der Zentrale Kronach:
The most important phone numbers of the Kronach headquarters

	Telefon:	FAX
Ersatzteilbestellungen:	(01 80) 522 1800	(01 80) 522 1806
Status von Reparaturen:	(01 80) 522 1805	(0 92 61) 99 412
Support Farbfernsehen:	(01 80) 522 1801	(0 92 61) 99 730
Support Video/Camcorder	(01 80) 522 1802	(0 92 61) 99 730
Support Telefone/Telekom.	(01 80) 522 1803	(0 92 61) 99 730
Support HiFi:	(01 80) 522 1804	(0 92 61) 99 730
Support Home MultiMedia	(01 80) 522 1807	(0 92 61) 99 730

Loewe-Service und Logistik

LOEWE OPTA GmbH
Service + Logistik
Zentrale Kronach
96305 Kronach • Postfach 1554
96317 Kronach • Industriestraße 11

Hinweis! Ersatzteilbestellung nur über
Service + Logistik / Zentrale 96317
Kronach

Note! Spare parts orders only through
Service + Logistics / Headquarters in
Kronach

CL96532158_014.pdf
091299

4. Block and wiring diagram, dismantling, exploded view and oscillograms

Blockdiagram

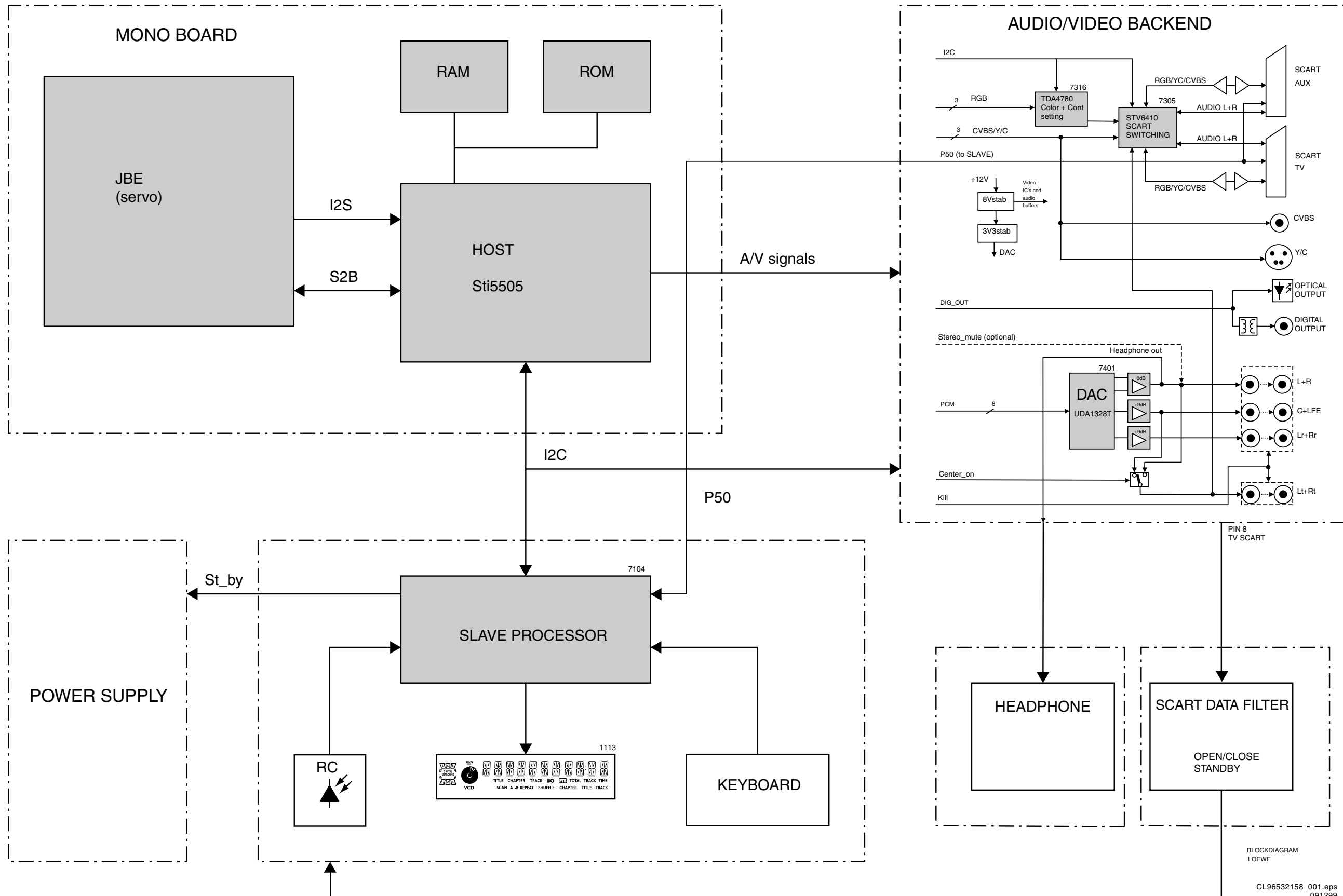

Dismantling instructions

DISMANTLING INSTRUCTIONS

See exploded view for item numbers

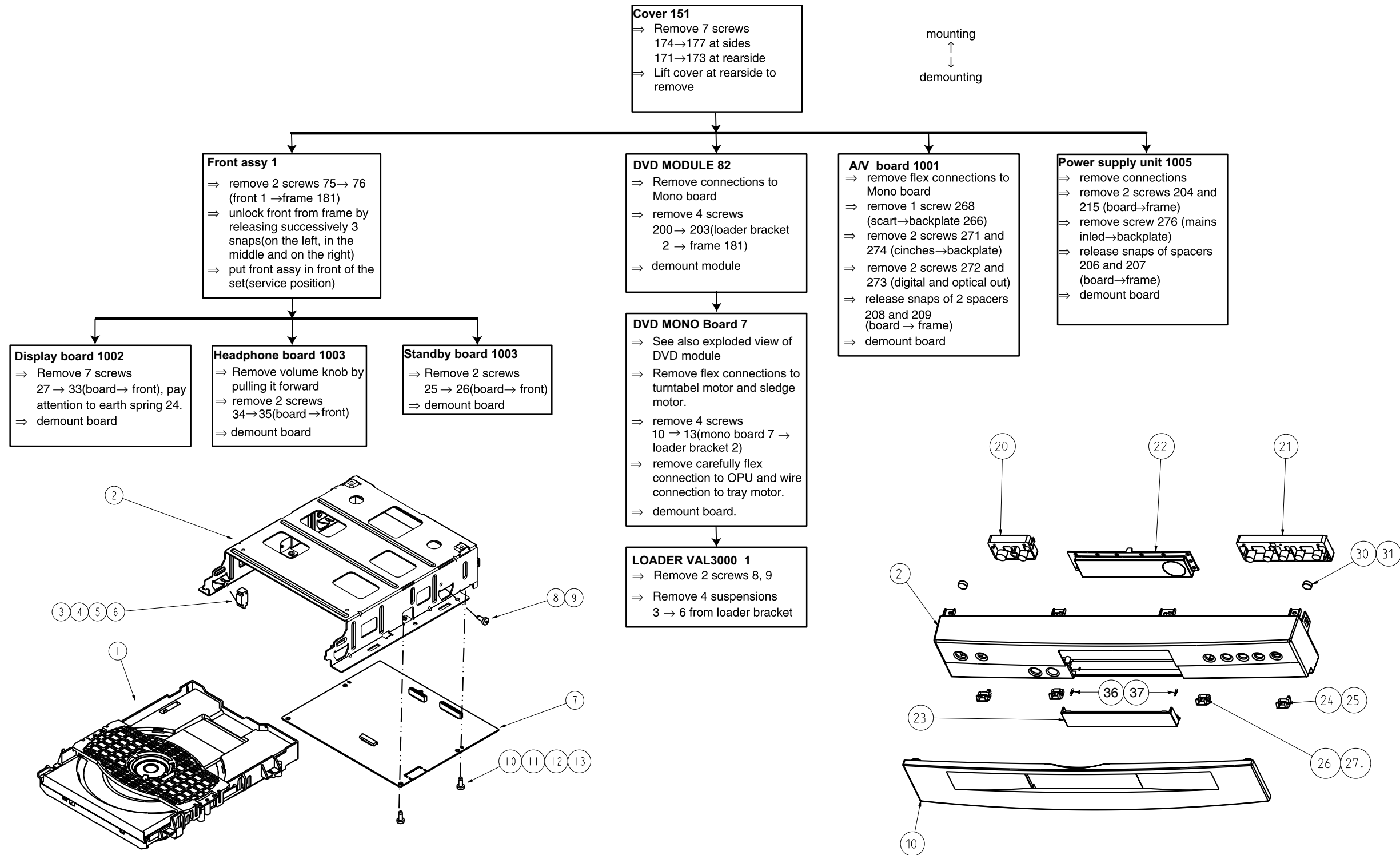

Exploded view

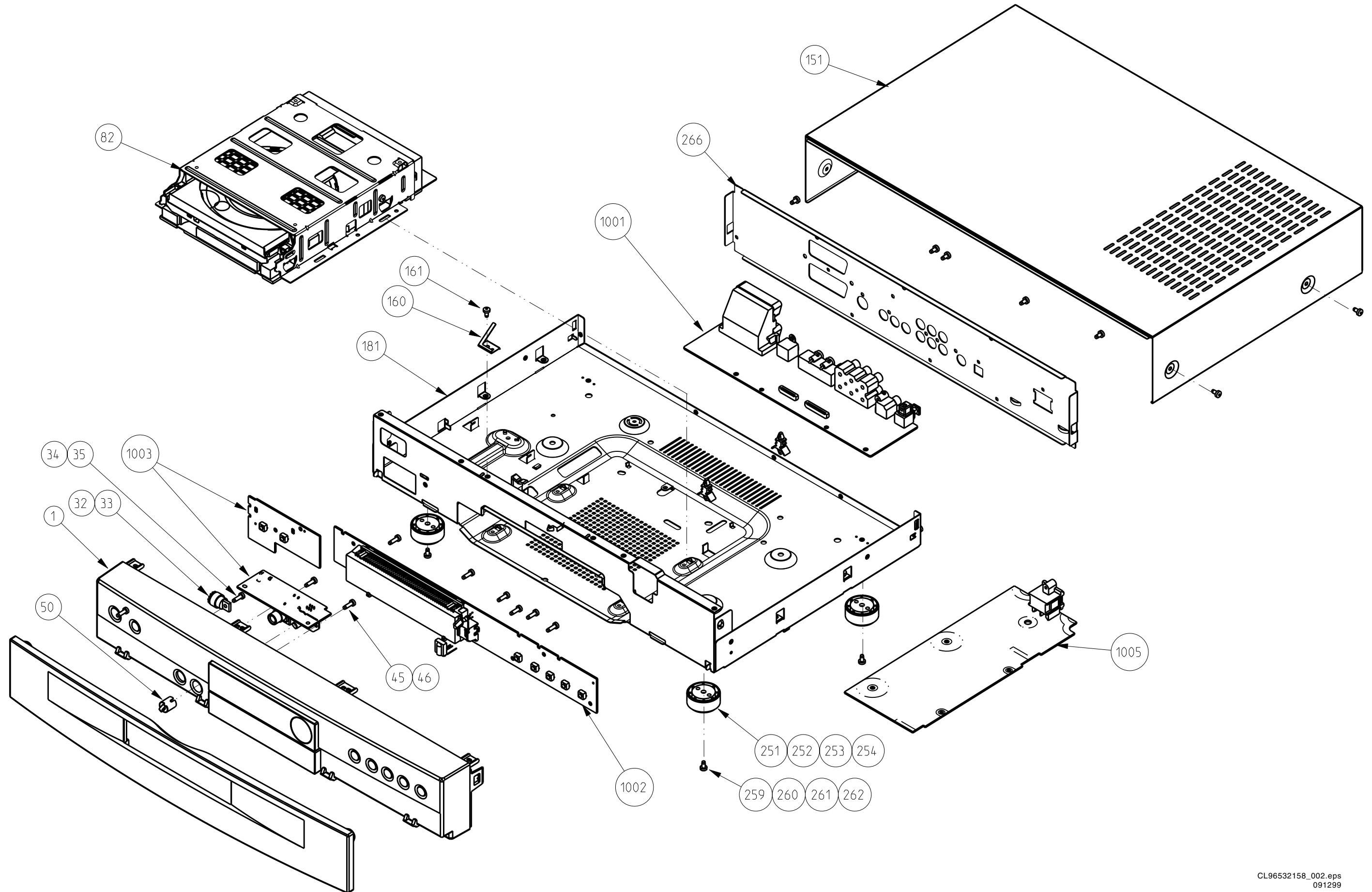

Exploded view

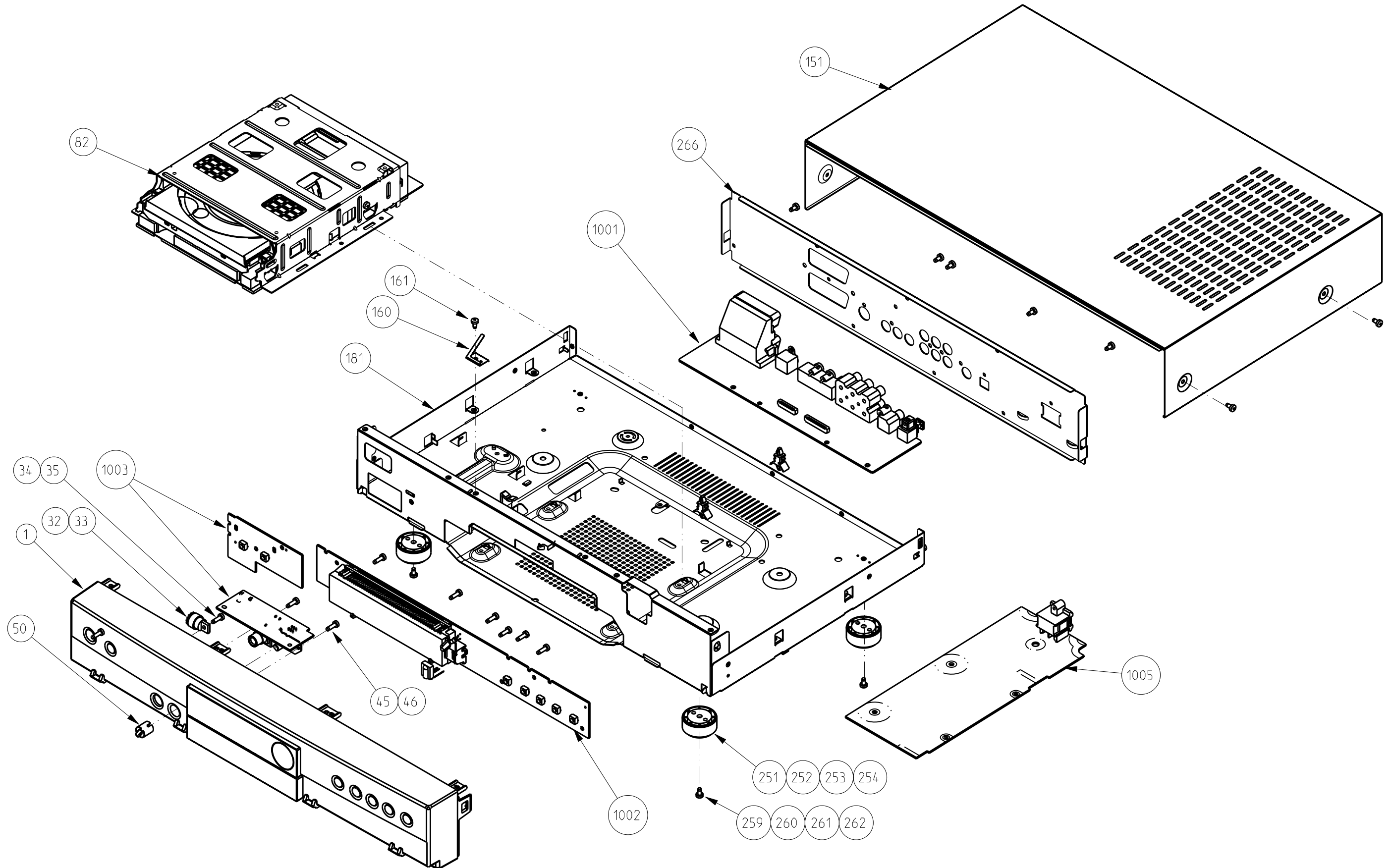

Wiring diagram

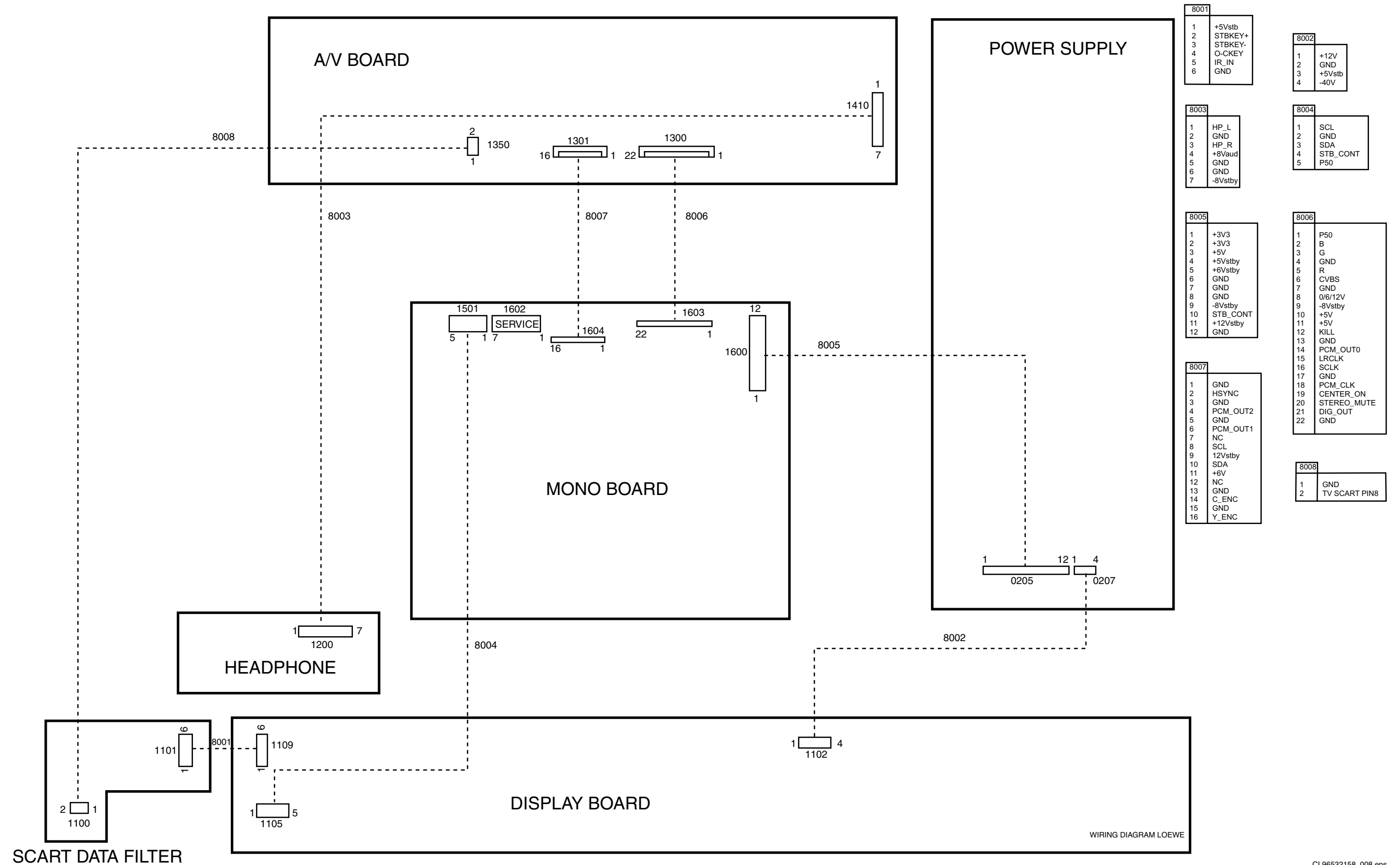

WIRING DIAGRAM LOEWE

5. Electrical diagrams and Print-layouts

Power supply

POWER SUPPLY

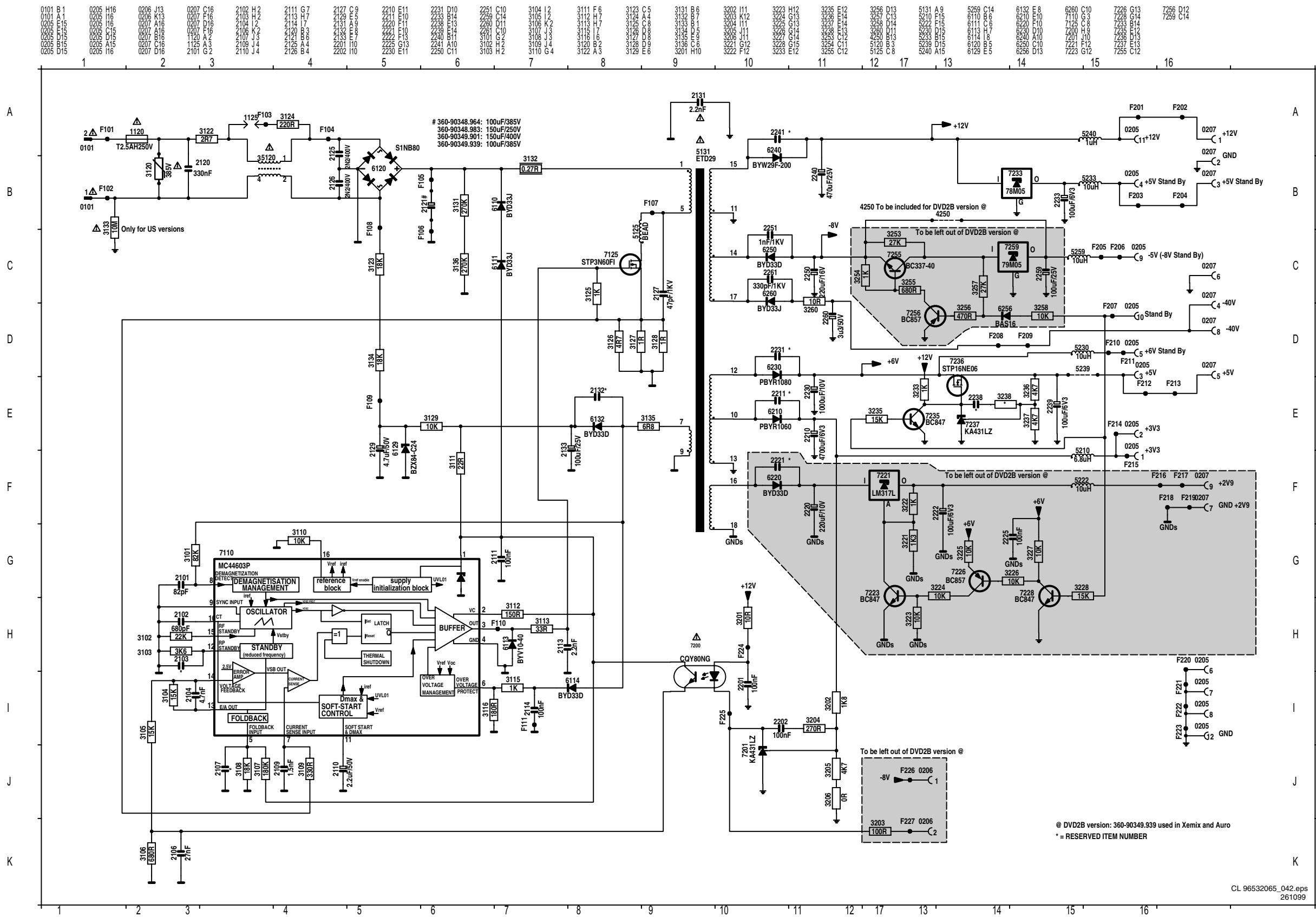

Power supply

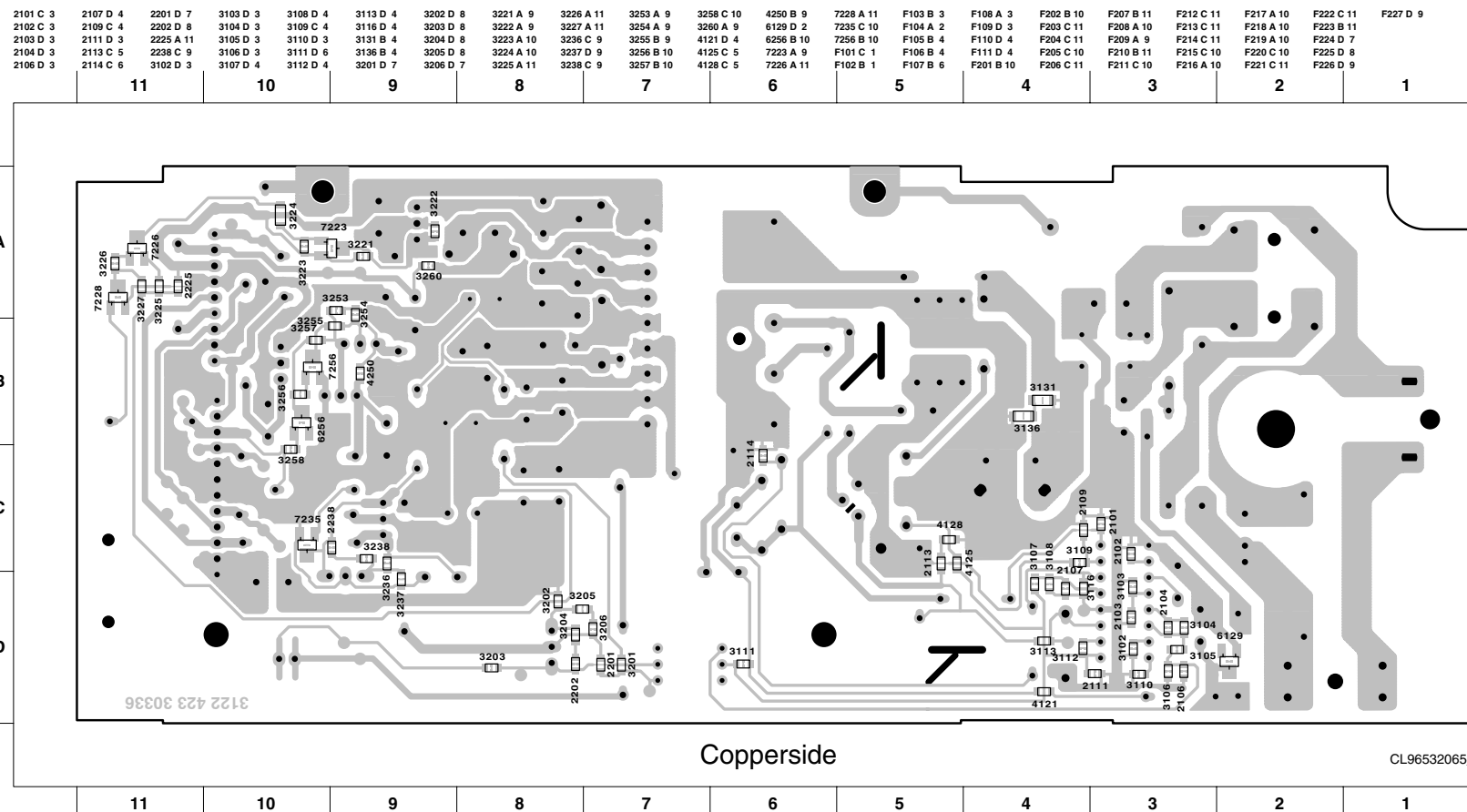
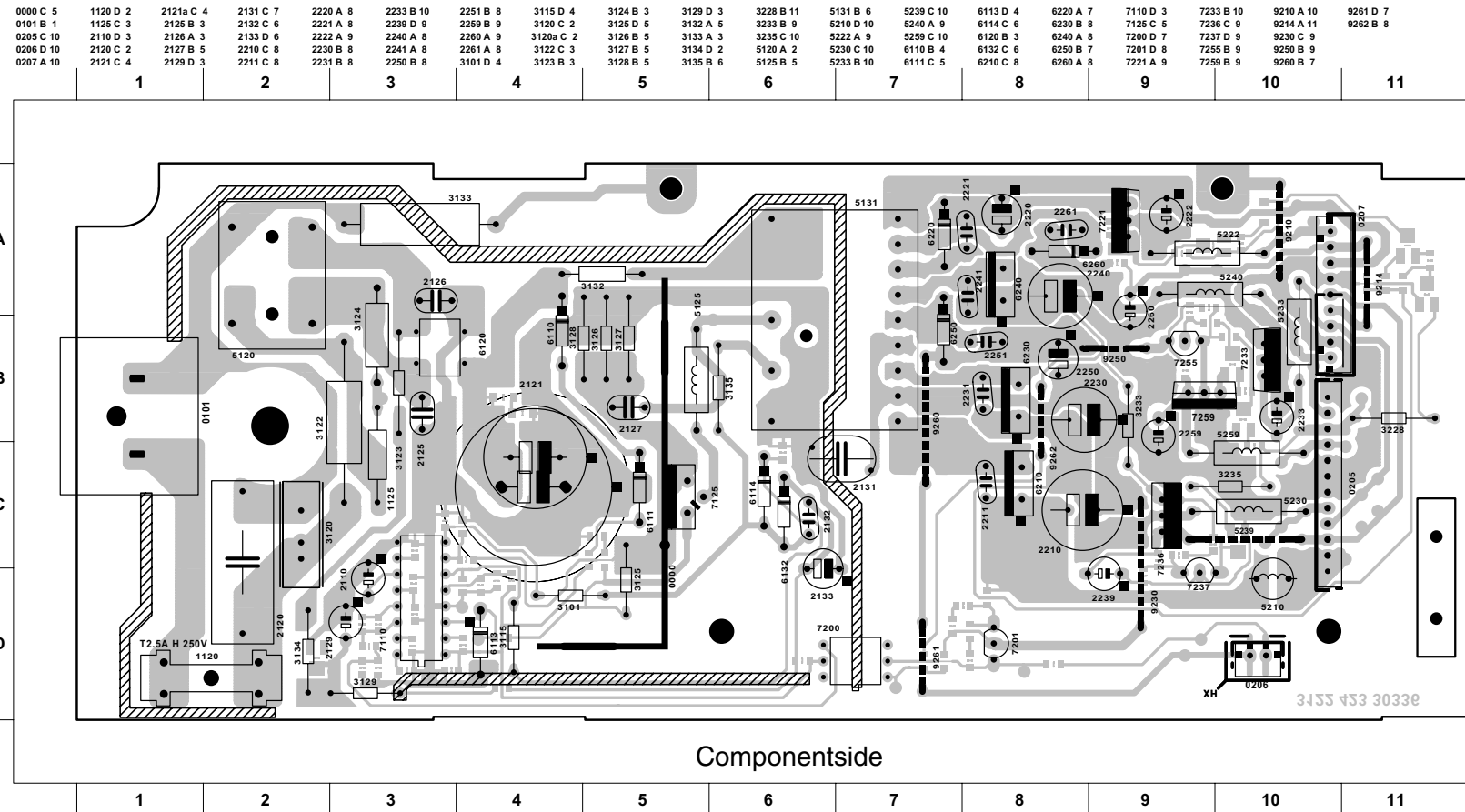

Headphone panel and standby PWB

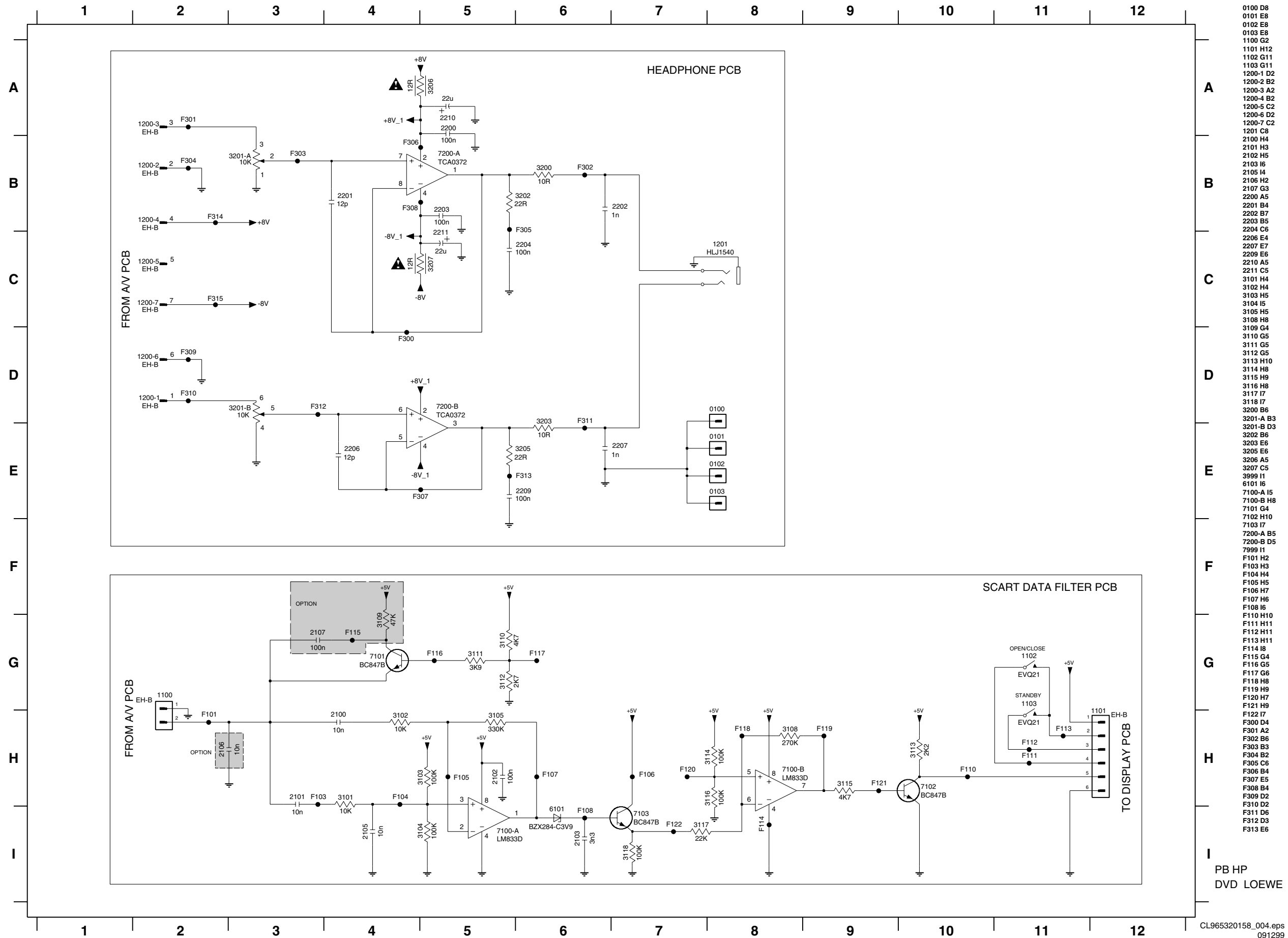

Display

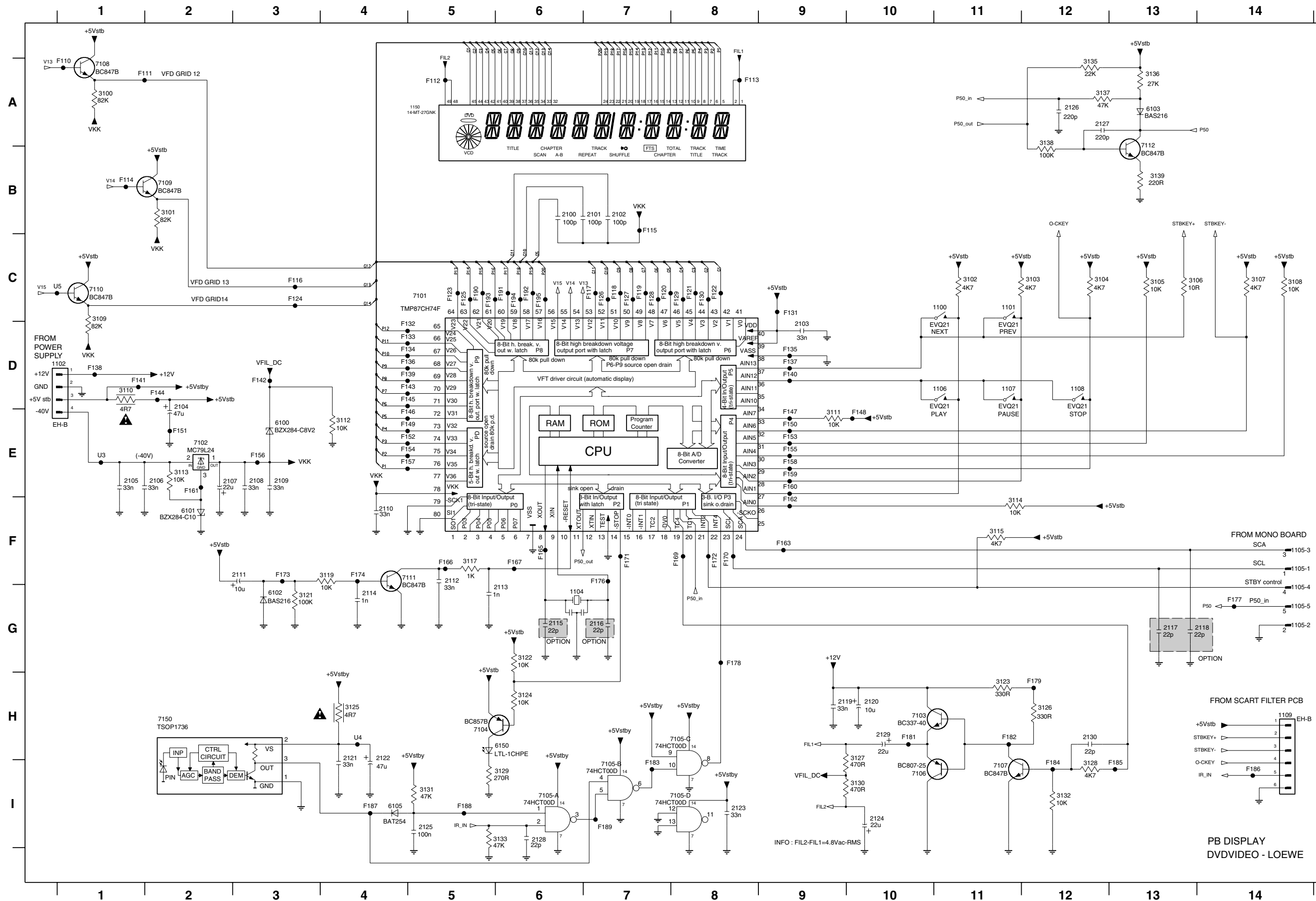

- 1100 C11
- 1101 C11
- 1102 D1
- 1104 G6
- 1105-1 F14
- 1105-2 G14
- 1105-3 F14
- 1105-4 G14
- 1105-5 G14
- 1106 D11
- 1107 D11
- 1108 D12
- 1109 H14
- 1150 A5
- 2100 B6
- 2101 B7
- 2102 B7
- 2103 D9
- 2104 D2
- 2105 E1
- 2106 E2
- 2107 E2
- 2108 E3
- 2109 E3
- 2110 F4
- 2111 F3
- 2112 F5
- 2113 F6
- 2114 G4
- 2115 G6
- 2116 G7
- 2117 G13
- 2118 G14
- 2119 H9
- 2120 H10
- 2121 H4
- 2122 H4
- 2123 H8
- 2124 I10
- 2125 I5
- 2126 A12
- 2127 A12
- 2128 I6
- 2129 H10
- 2130 H12
- 3100 A1
- 3101 B2
- 3102 C11
- 3103 C12
- 3104 C12
- 3105 C13
- 3106 C13
- 3107 C14
- 3108 C14
- 3109 C1
- 3110 D1
- 3111 E9
- 3112 E4
- 3113 E2
- 3114 F11
- 3115 F11
- 3117 F5
- 3119 F4
- 3121 G3
- 3122 G6
- 3123 H11
- 3124 H6
- 3125 H4
- 3126 H12
- 3127 H10
- 3128 I12
- 3129 I6
- 3130 I10
- 3131 I5
- 3132 I12
- 3133 I6
- 3135 A13
- 3136 A13
- 3137 A12
- 3138 A12
- 3139 B13
- 6100 E3
- 6101 F2
- 6102 G3
- 6103 A13
- 6105 I4
- 6150 H6
- 7101 C5
- 7102 E2
- 7103 H10
- 7104 H5
- 7105-A I6
- 7105-B I7
- 7105-C H7
- 7105-D I7
- 7106 I10
- 7107 I11
- 7108 A1
- 7109 B2
- 7110 C1
- 7111 F4
- 7112 B13
- 7150 H2

Display PWB

1100 A9 1101 A8 1102 A6 1104 A4 1105 A1 1106 A9 1107 A7 1108 A8 1109 A1 1150 A3 2104 A6 2107 A6 2111 A8 2120 A9 2122 A6 2124 A9 2129 A9 6150 A6 7102 A6 7103 A9 7150 A6

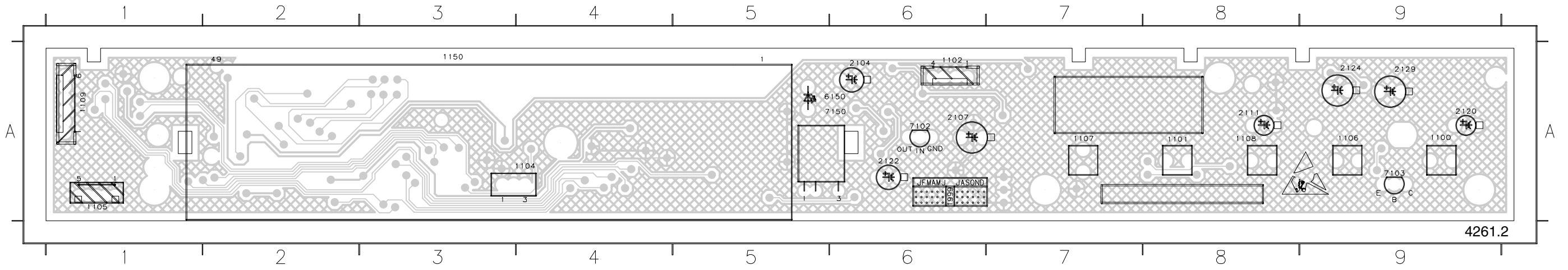

2100 A8 2105 A4 2110 A6 2115 A6 2119 A1 2126 A7 3100 A8 3104 A2 3108 A2 3109 A8 3110 A8 3111 A8 3112 A3 3113 A3 3114 A3 3115 A3 3116 A3 3117 A6 3118 A2 3119 A2 3120 A2 3121 A2 3122 A4 3123 A1 3124 A1 3125 A1 3126 A1 3127 A1 3128 A3 3129 A3 3130 A3 3131 A5 3132 A1 3133 A9 3134 A9 3135 A9 3136 A9 3137 A9 3138 A9 3139 A9 3140 A9 3141 A9 3142 A9 3143 A9 3144 A9 3145 A9 3146 A9 3147 A9 3148 A9 3149 A9 3150 A9 3151 A9 3152 A9 3153 A9 3154 A9 3155 A9 3156 A9 3157 A9 3158 A9 3159 A9 3160 A9 3161 A9 3162 A9 3163 A9 3164 A9 3165 A9 3166 A9 3167 A9 3168 A9 3169 A9 3170 A9 3171 A9 3172 A9 3173 A9 3174 A9 3175 A9 3176 A9 3177 A9 3178 A9 3179 A9 3180 A9 3181 A9 3182 A9 3183 A9 3184 A9 3185 A9 3186 A9 3187 A9 3188 A9 3189 A9 3190 A9 3191 A9 3192 A9 3193 A9 3194 A9 3195 A9 3196 A9 3197 A9 3198 A9 3199 A9 7999 A6

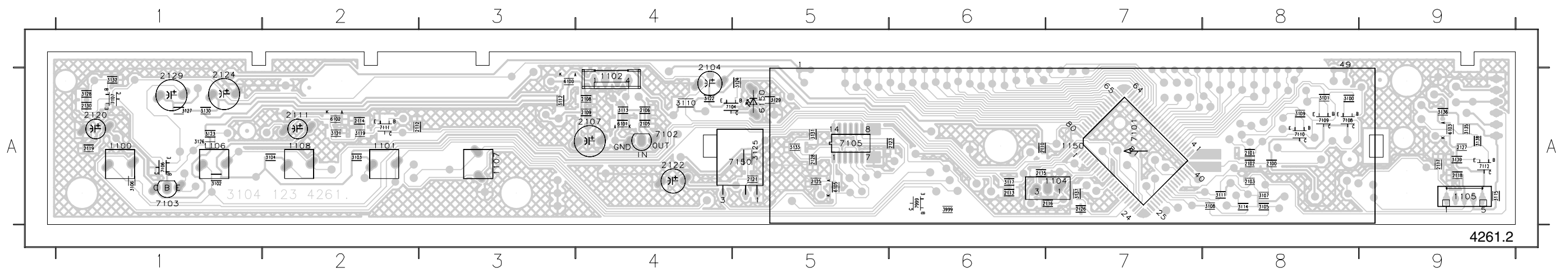

TROUBLESHOOTING DISPLAY BOARD

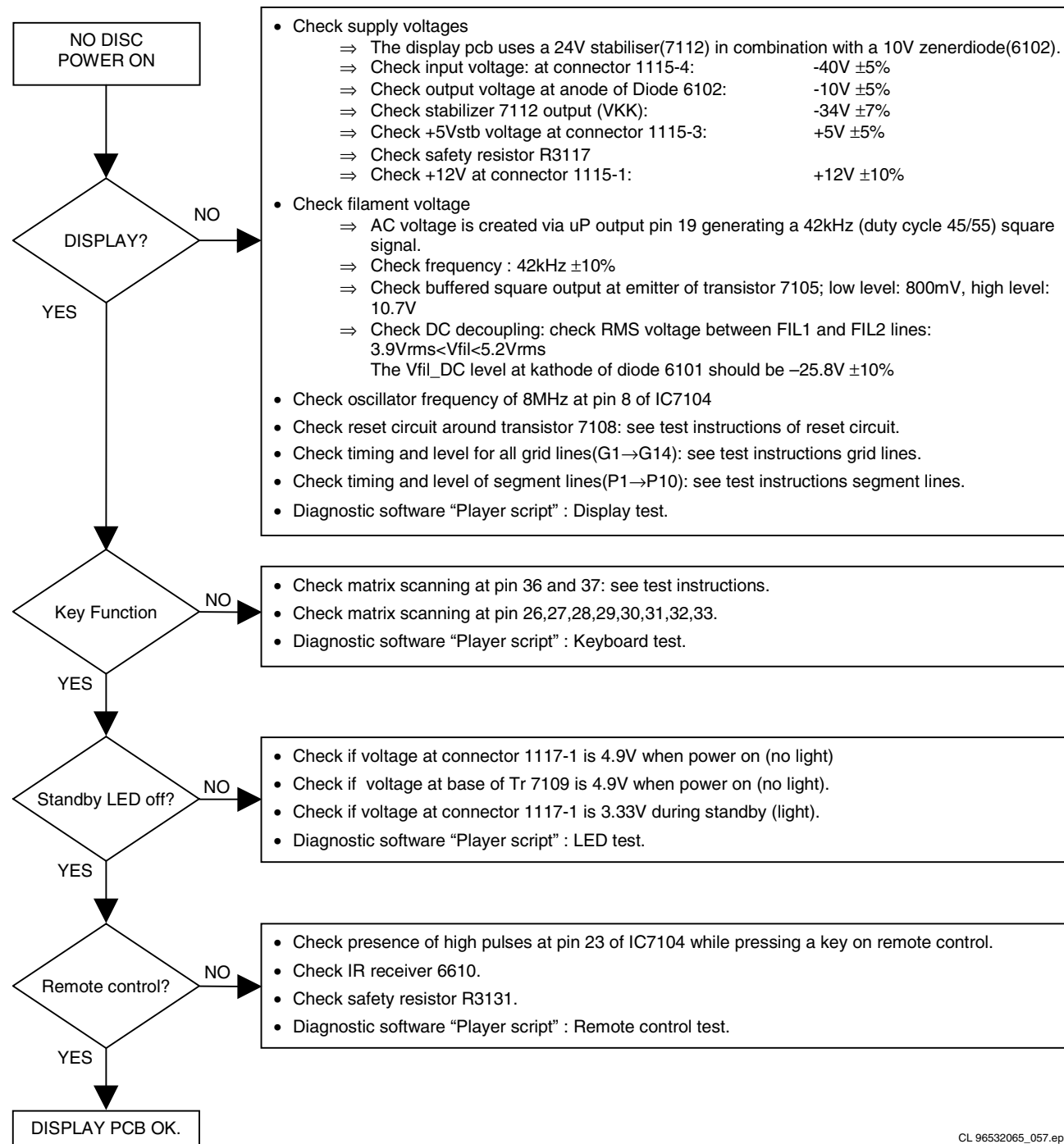

CL 96532065_057.eps
130799

TROUBLESHOOTING A/V BOARD

Testing of A/V board can be done using diagnostic software "Player script". Mono board is used to generate a sound with the sound tests SND-1 and SND-2 or a VIDEO signal with the picture test PIC-1. Functional control of scart switching and RGB video processing is also possible. See description in chapter "Diagnostic Software: Script Interfaces"

AUDIO PART

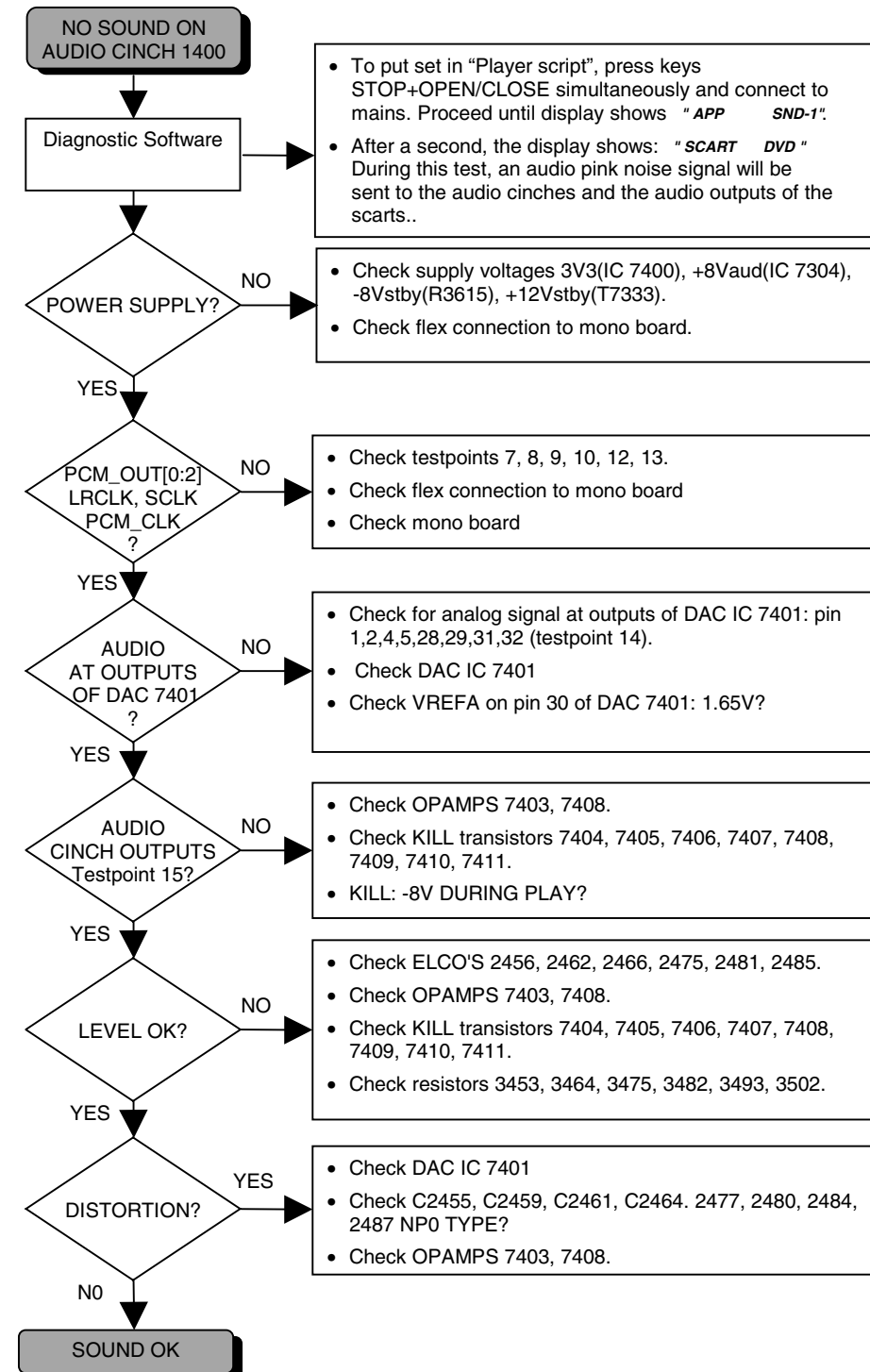

CL96532126_002.eps
261099

Audio-1

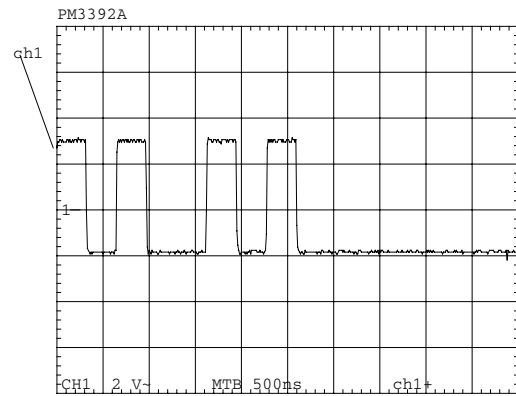

TP7: PCM_OUT0

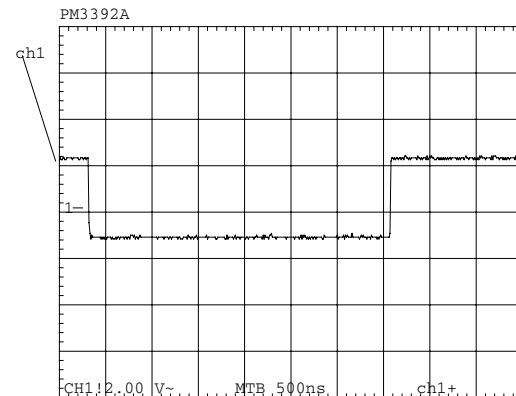

TP12: PCM_OUT2

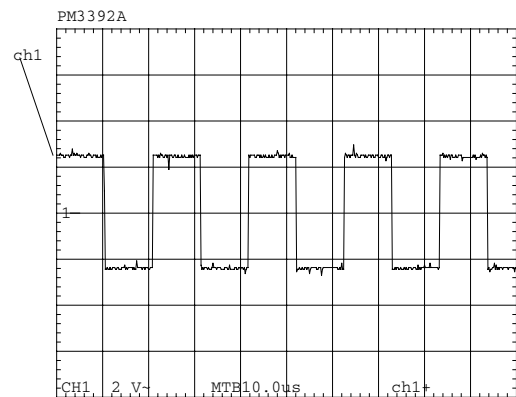

TP8: LRCLK

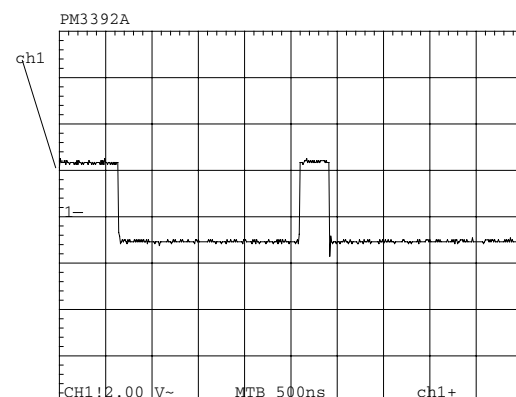

TP13: PCM_OUT1

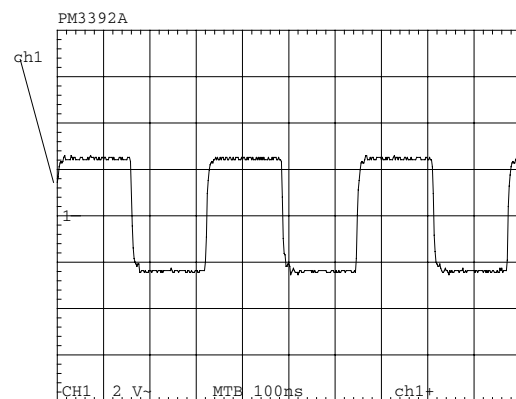

TP9: SCLK

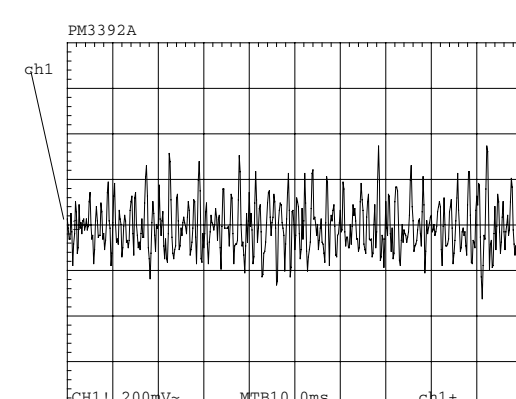

TP14: ANALOG OUT DAC (PINK NOISE)

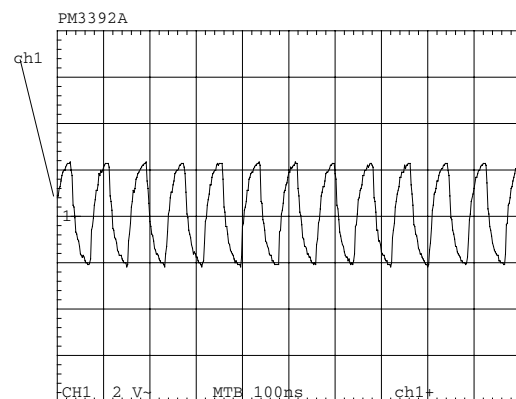

TP10: PCM_CLK

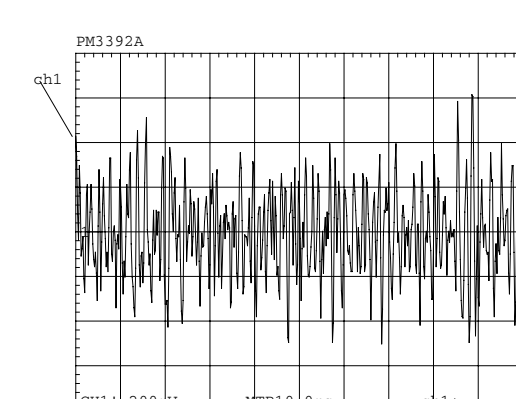

TP15: ANALOG OUT AUDIO CINCH (PINK NOISE)

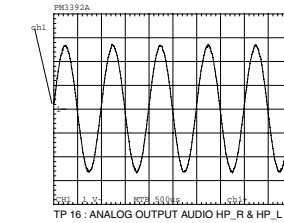

TP16: ANALOG OUTPUT AUDIO HP_R & HP_L

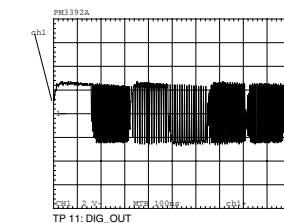

TP11: DIG_OUT

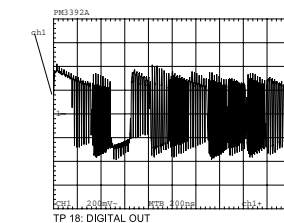

TP18: DIGITAL OUT

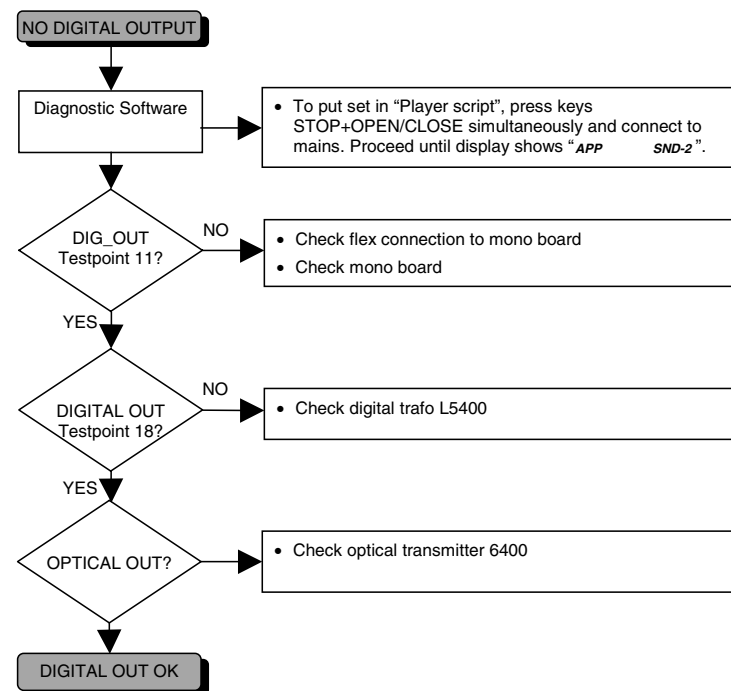
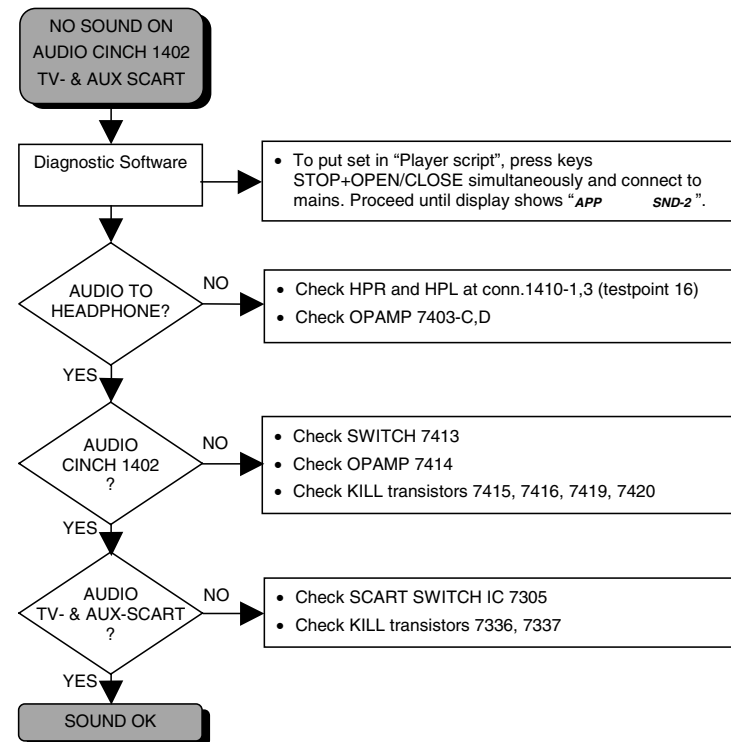

Video-1

VIDEO PART

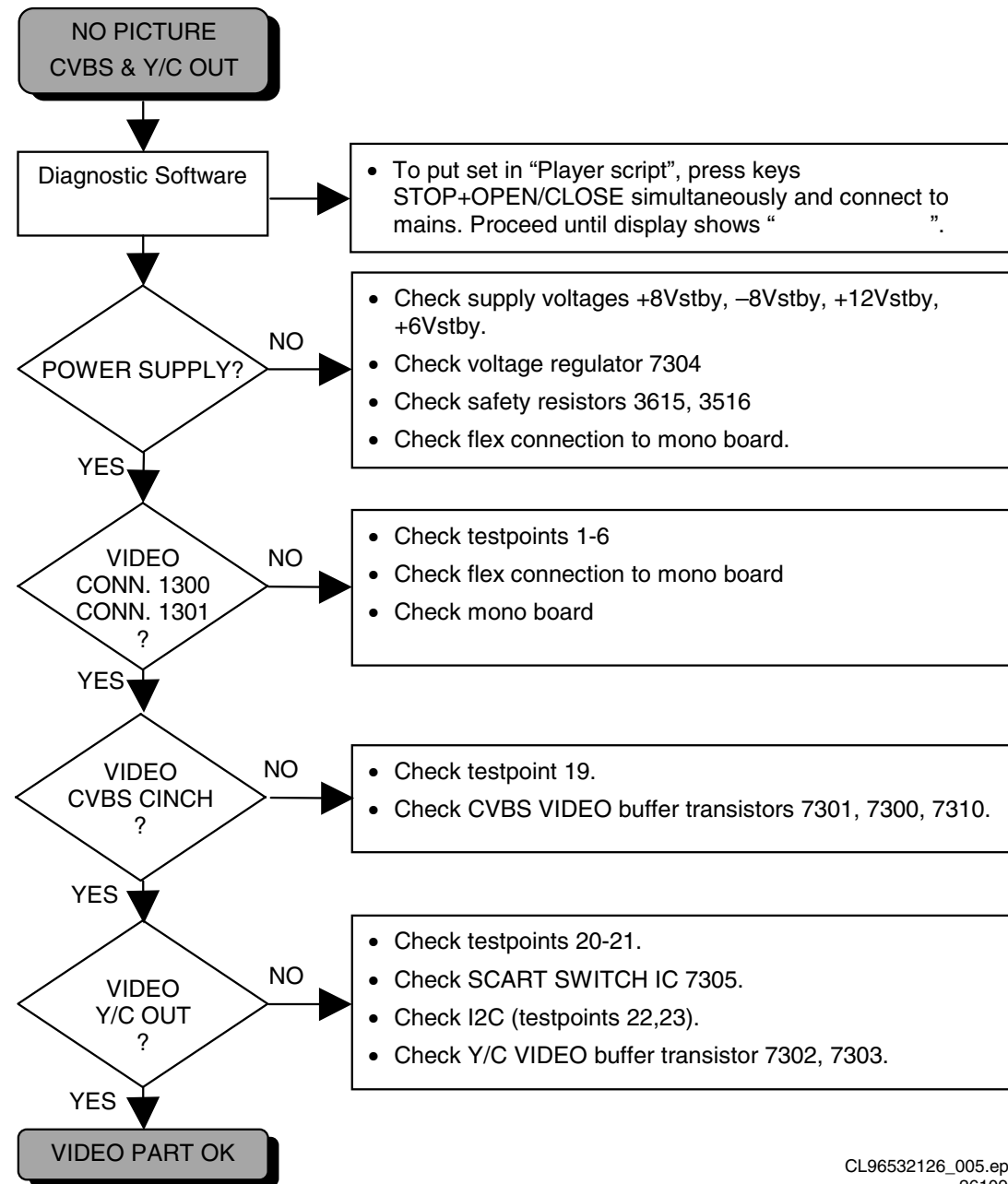

CL96532126_005.eps
261099

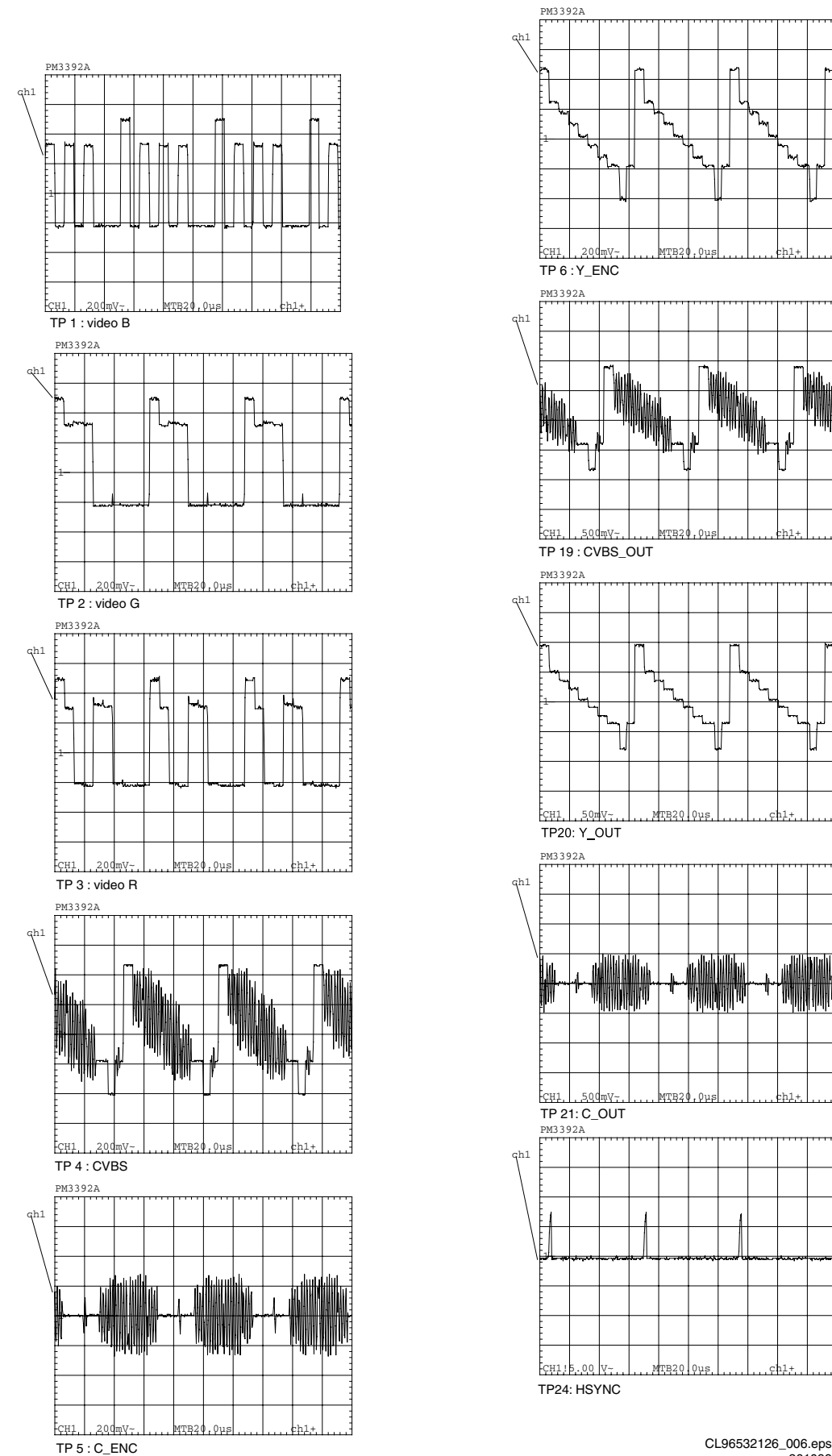

CL96532126_006.eps
261099

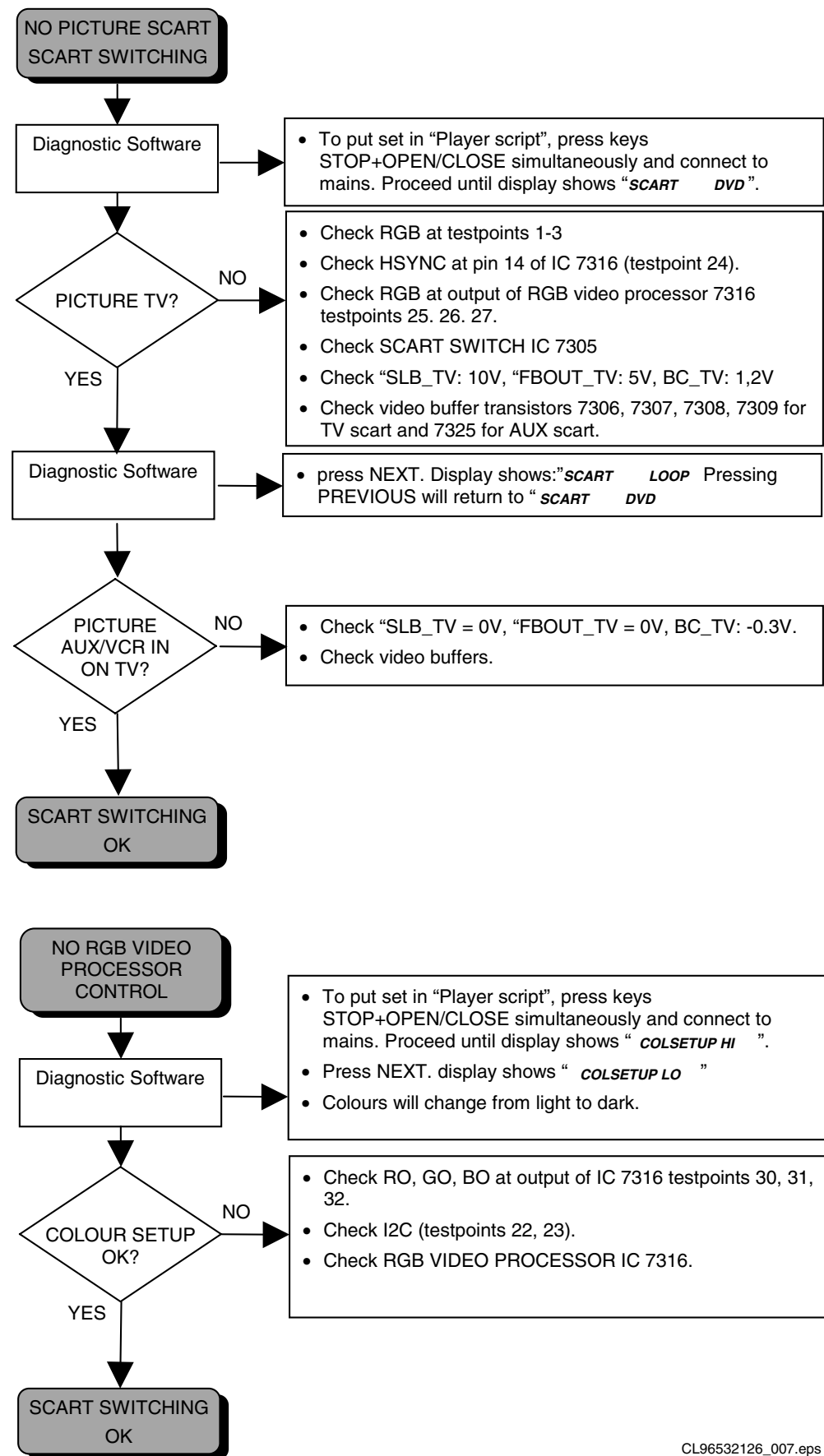

Video-2

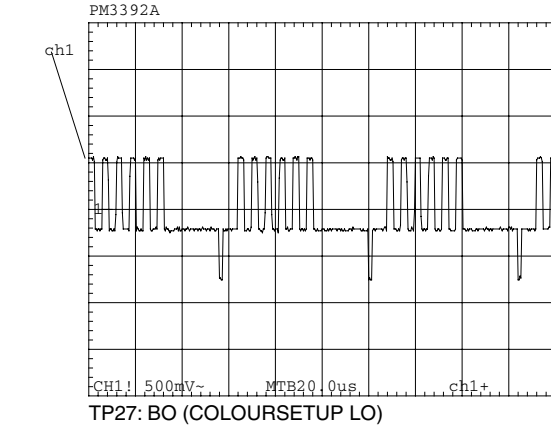
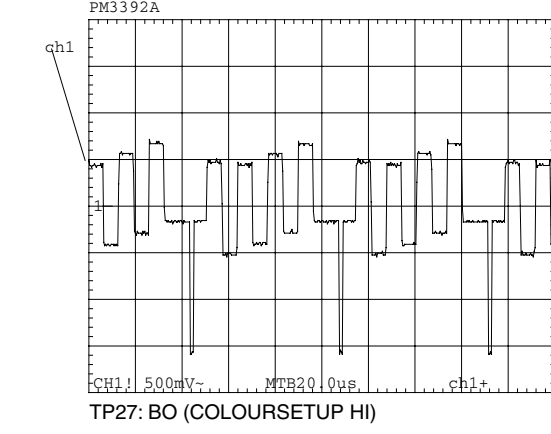
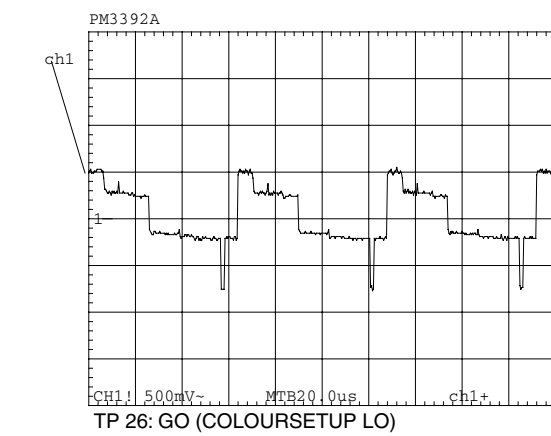
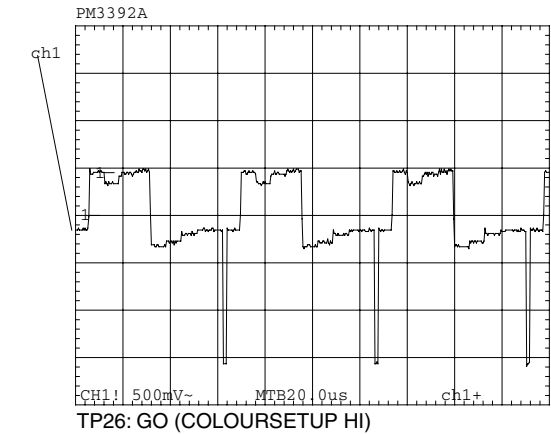
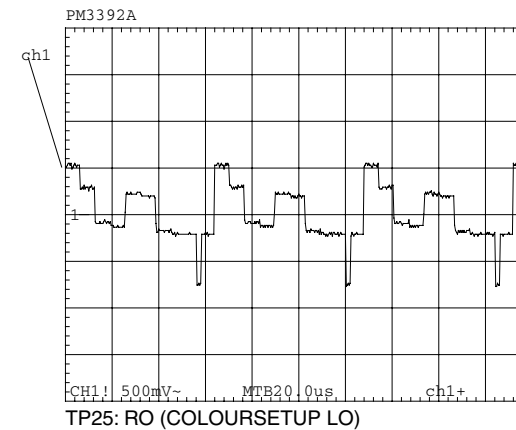
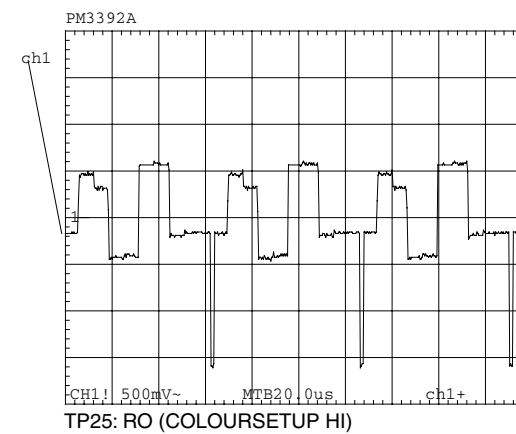
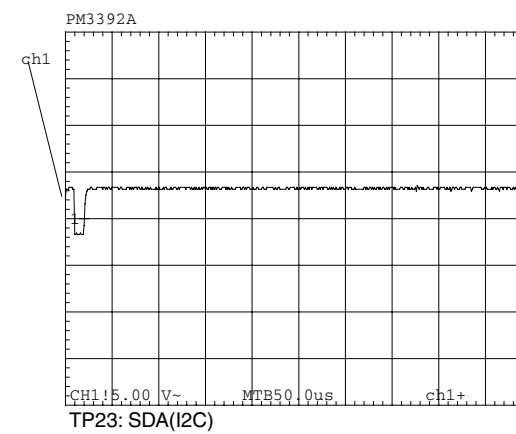
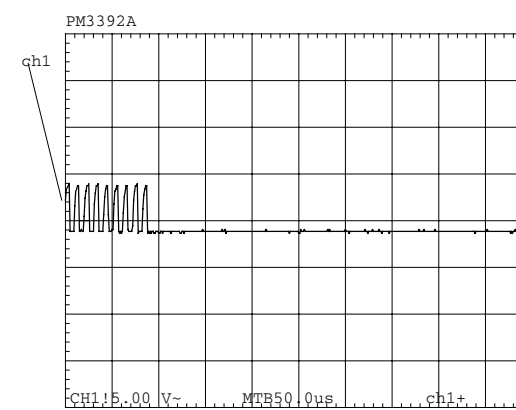

1300-1 A1	1301-14 G1	2360 D10	2373 G14	2389 C3	2401 E9	2419 B3	3350 C7	3414 E4	3612 H7	3621 F2	4304 F13	7316 C4	7999 H10	F118 C12	F129 C15	F142 D1	F158 E11	F173 F12	F196 C5	F215 D9	F230 E4	F260 A1	F270 A3	F279 F2
1300-2 C1	1301-15 E1	2361 D11	2374 G3	2390 D4	2403 E9	3321 D10	3352 B5	3415 E4	3613 H6	3622 F1	4305 F13	7322 F4	F105 A1	F119 C13	F130 D1	F143 D15	F159 E15	F176 G13	F200 C5	F217 C4	F231 E9	F261 E15	F271 B2	F280 F2
1300-3 C1	1301-16 E1	2362 D11	2379 C5	2391 D3	2405 F6	3322 D10	3353 C5	3418 F6	3614 H7	3623 F2	4307 A8	7329 H6	F106 C1	F120 H4	F131 C10	F144 G1	F160 E11	F177 G14	F201 C5	F221 D4	F233 E9	F262 E2	F272 B2	F281 G1
1300-5 C1	1301-2 D1	2363 E15	2380 C6	2392 D9	2406 F7	3321 B8	3400 D3	3419 F6	3615 A3	3624 F1	4308 A8	7330 H7	F109 C1	F121 H5	F132 C15	F146 C15	F161 E15	F180 G14	F202 C6	F223 D4	F237 E6	F263 E11	F273 B2	F282 C14
1300-6 G1	1301-8 D1	2364 E15	2381 C7	2393 D4	2407 F8	3334 C8	3401 D3	3420 F8	3616 B2	3625 G1	4309 A8	7331 A2	F110 C1	F122 C13	F135 E1	F150 E1	F162 E11	F181 G13	F203 C6	F224 D9	F238 E7	F265 H7	F274 B1	F301 B1
1300-8 A1	1301-9 E1	2365 E15	2384 C3	2394 D9	2412 H4	3338 H13	3403 D3	3424 F4	3617 B1	3626 A2	6302 B1	7332 B2	F112 G2	F123 C14	F136 C15	F151 E11	F168 F13	F182 G3	F204 C7	F225 D4	F242 E7	F266 H7	F275 E2	
1300-9 A1	1301-9 E1	2367 F12	2386 C9	2397 D4	2415 E1	3339 H13	3404 D3	3433 H4	3618 B2	3627 E2	6303 B1	7333 F2	F113 A1	F124 C14	F138 D1	F153 E11	F169 F13	F185 A10	F211 C4	F226 D9	F243 E8	F267 H7	F276 E3	
1301-10 D1	2352 C13	2370 G3	2387 C3	2398 D3	2416 E11	3340 H14	3405 D3	3461 H6	3619 B2	3628 F2	7304 H3	7334 F2	F116 C13	F125 C14	F139 D11	F154 C15	F170 F12	F188 A10	F213 C9	F227 D4	F244 F4	F268 H6	F277 F2	
1301-13 D1	2354 H3	2372 G13	2388 D9	2400 E4	2417 D15	3341 H14	3406 E3	3611 H6	3620 E3	3999 H9	7305 C11	7335 G1	F117 C12	F128 D1	F141 D11	F156 C15	F172 F12	F189 A10	F214 C4	F228 D4	F249 F4	F269 A2	F278 F1	

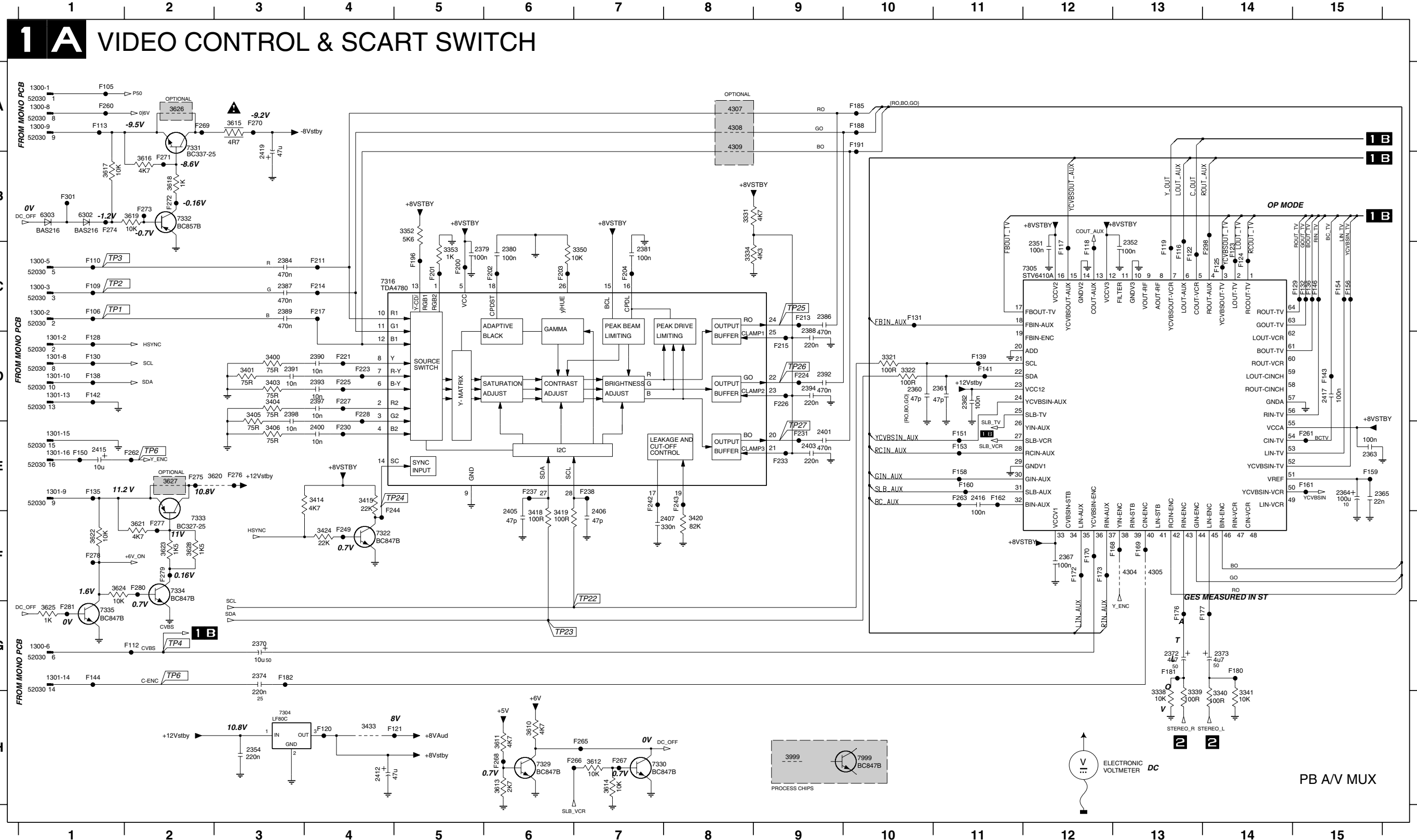

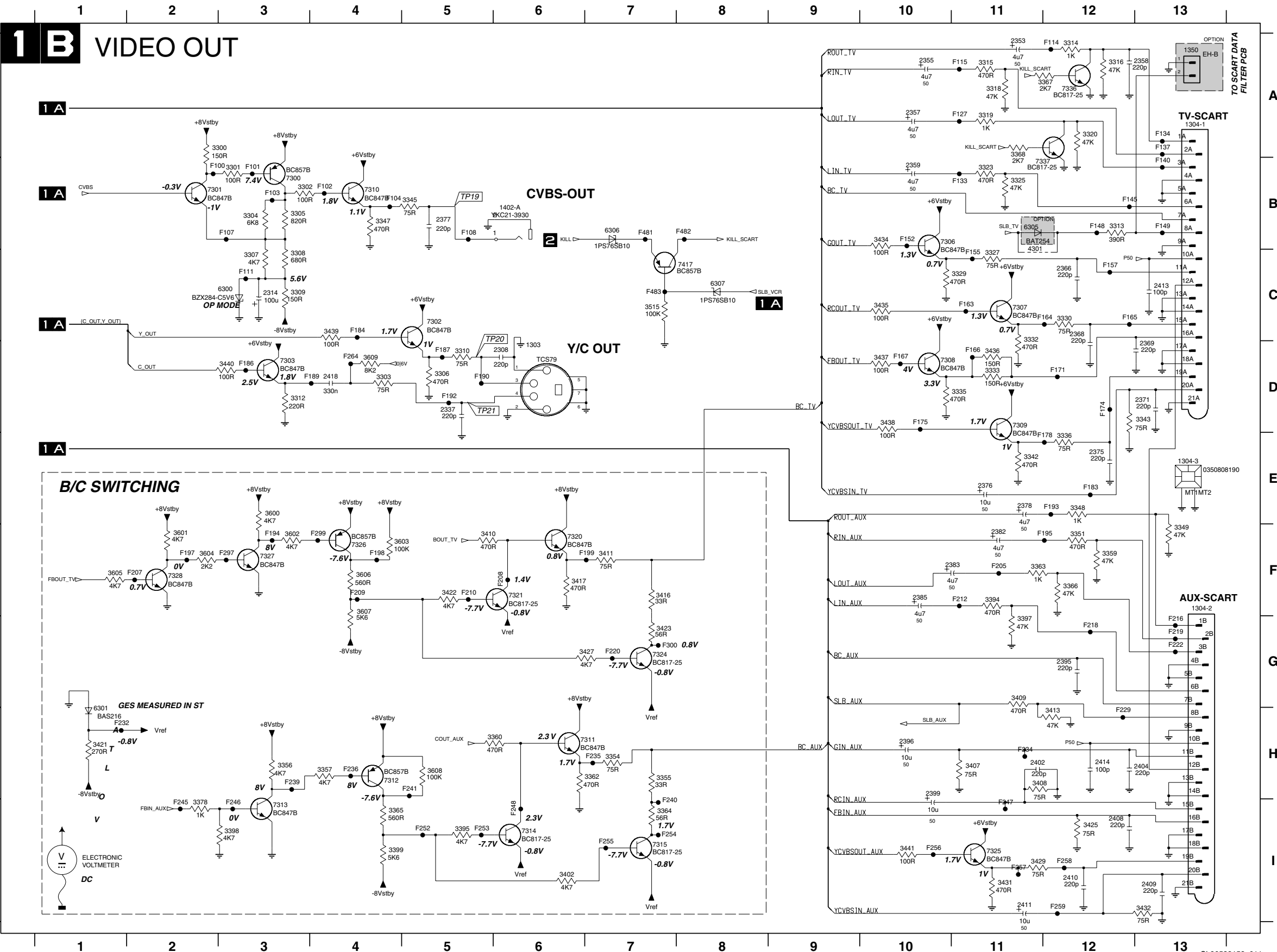

- 1303 D6
- 1304-1 A13
- 1304-2 F13
- 1304-3 E13
- 1350 A13
- 1402-A B6
- 2308 D6
- 2314 C3
- 2337 D5
- 2353 A11
- 2355 A10
- 2357 A10
- 2358 A13
- 2359 B10
- 2366 C12
- 2368 C12
- 2369 C13
- 2371 D13
- 2375 E12
- 2376 E11
- 2377 B5
- 2378 E11
- 2382 F11
- 2383 F11
- 2385 F10
- 2395 G12
- 2396 H10
- 2399 H10
- 2402 H11
- 2404 H13
- 2408 I12
- 2409 I13
- 2410 I12
- 2411 I11
- 2413 C13
- 2414 H12
- 2418 D4
- 3300 A3
- 3301 B3
- 3302 B3
- 3303 C3
- 3304 B3
- 3305 B3
- 3306 D5
- 3307 C3
- 3308 C3
- 3309 C3
- 3310 D5
- 3312 D3
- 3313 B12
- 3314 A12
- 3315 A11
- 3316 A12
- 3318 A11
- 3319 A11
- 3320 A12
- 3323 B11
- 3325 B11
- 3327 C11
- 3329 C11
- 3330 C12
- 3332 D11
- 3333 D11
- 3335 D11
- 3336 E12
- 3342 E11
- 3343 D13
- 3345 B5
- 3347 B4
- 3348 E12
- 3349 F13
- 3351 F12
- 3352 H7
- 3355 H7
- 3356 H3
- 3357 H4
- 3359 F12
- 3360 H6
- 3362 H7
- 3363 F11
- 3364 F7
- 3365 I4
- 3366 F12
- 3367 A12
- 3368 A11
- 3378 I2
- 3394 F11
- 3395 I5
- 3397 G11
- 3398 I3
- 3399 I4
- 3402 I6
- 3407 H11
- 3408 H11
- 3409 G11
- 3410 F5
- 3411 F7
- 3413 H12
- 3416 F7
- 3417 F6
- 3421 H1
- 3422 F5
- 3423 G7
- 3425 I12
- 3427 G7
- 3429 I11
- 3431 I1
- 3432 I13
- 3434 B10
- 3435 C10
- 3436 D11
- 3437 D10
- 3438 D10
- 3439 C4
- 3440 D3
- 3441 I10
- 3515 C7
- 3600 E3
- 3601 F2
- 3602 F3
- 3603 F4
- 3604 F2
- 3605 F1
- 3606 F4
- 3607 F4
- 3608 H5
- 3609 D4
- 4301 C11
- 6300 C3
- 6301 H1
- 6305 B11
- 6306 B7
- 6307 C8
- 7300 B3
- 7301 B2
- 7302 C5
- 7303 D3
- 7306 B10
- 7307 C11
- 7308 D10
- 7309 D11
- 7310 B4
- 7311 H6
- 7312 H4
- 7313 I3
- 7314 I6
- 7315 I7
- 7320 F6
- 7321 F6
- 7324 G7
- 7325 I11
- 7326 F4
- 7327 F3
- 7328 F2
- 7336 A12
- 7337 B11
- 7417 C8
- F100 B2
- F101 B3
- F102 B4
- F103 B3
- F104 B4
- F107 B3
- F108 B5
- F109 B5
- F111 C3
- F114 A12
- F115 A11
- F116 C12
- F117 D12
- F118 E12
- F119 D5
- F120 F4
- F121 D12
- F122 G13
- F123 H12
- F124 H11
- F125 I5
- F126 D5
- F127 A11
- F128 G13
- F129 G12
- F130 G7
- F131 C7
- F132 B8
- F133 C7
- F134 B7
- F135 C7
- F136 C7
- F137 C7
- F138 C7
- F139 C7
- F140 B3
- F141 B3
- F142 B3
- F143 B3
- F144 B3
- F145 B3
- F146 B3
- F147 B3
- F148 B3
- F149 B3
- F150 B3
- F151 B3
- F152 B3
- F153 B3
- F154 B3
- F155 B3
- F156 B3
- F157 B3
- F158 B3
- F159 B3
- F160 B3
- F161 B3
- F162 B3
- F163 B3
- F164 B3
- F165 B3
- F166 B3
- F167 B3
- F168 B3
- F169 B3
- F170 B3
- F171 B3
- F172 B3
- F173 B3
- F174 B3
- F175 B3
- F176 B3
- F177 B3
- F178 B3
- F179 B3
- F180 B3
- F181 B3
- F182 B3
- F183 B3
- F184 B3
- F185 B3
- F186 B3
- F187 B3
- F188 B3
- F189 B3
- F190 B3
- F191 B3
- F192 B3
- F193 B3
- F194 B3
- F195 B3
- F196 B3
- F197 B3
- F198 B3
- F199 B3
- F200 B3
- F201 B3
- F202 B3
- F203 B3
- F204 B3
- F205 B3
- F206 B3
- F207 B3
- F208 B3
- F209 B3
- F210 B3
- F211 B3
- F212 B3
- F213 B3
- F214 B3
- F215 B3
- F216 B3
- F217 B3
- F218 B3
- F219 B3
- F220 B3
- F221 B3
- F222 B3
- F223 B3
- F224 B3
- F225 B3
- F226 B3
- F227 B3
- F228 B3
- F229 B3
- F230 B3
- F231 B3
- F232 B3
- F233 B3
- F234 B3
- F235 B3
- F236 B3
- F237 B3
- F238 B3
- F239 B3
- F240 B3
- F241 B3
- F242 B3
- F243 B3
- F244 B3
- F245 B3
- F246 B3
- F247 B3
- F248 B3
- F249 B3
- F250 B3
- F251 B3
- F252 B3
- F253 B3
- F254 B3
- F255 B3
- F256 B3
- F257 B3
- F258 B3
- F259 B3
- F260 B3
- F261 B3
- F262 B3
- F263 B3
- F264 B3
- F265 B3
- F266 B3
- F267 B3
- F268 B3
- F269 B3
- F270 B3
- F271 B3
- F272 B3
- F273 B3
- F274 B3
- F275 B3
- F276 B3
- F277 B3
- F278 B3
- F279 B3
- F280 B3
- F281 B3
- F282 B3
- F283 B3
- F284 B3
- F285 B3
- F286 B3
- F287 B3
- F288 B3
- F289 B3
- F290 B3
- F291 B3
- F292 B3
- F293 B3
- F294 B3
- F295 B3
- F296 B3
- F297 B3
- F298 B3
- F299 B3
- F300 B3
- F301 B3
- F302 B3
- F303 B3
- F304 B3
- F305 B3
- F306 B3
- F307 B3
- F308 B3
- F309 B3
- F310 B3
- F311 B3
- F312 B3
- F313 B3
- F314 B3
- F315 B3
- F316 B3
- F317 B3
- F318 B3
- F319 B3
- F320 B3
- F321 B3
- F322 B3
- F323 B3
- F324 B3
- F325 B3
- F326 B3
- F327 B3
- F328 B3
- F329 B3
- F330 B3
- F331 B3
- F332 B3
- F333 B3
- F334 B3
- F335 B3
- F336 B3
- F337 B3
- F338 B3
- F339 B3
- F340 B3
- F341 B3
- F342 B3
- F343 B3
- F344 B3
- F345 B3
- F346 B3
- F347 B3
- F348 B3
- F349 B3
- F350 B3
- F351 B3
- F352 B3
- F353 B3
- F354 B3
- F355 B3
- F356 B3
- F357 B3
- F358 B3
- F359 B3
- F360 B3
- F361 B3
- F362 B3
- F363 B3
- F364 B3
- F365 B3
- F366 B3
- F367 B3
- F368 B3
- F369 B3
- F370 B3
- F371 B3
- F372 B3
- F373 B3
- F374 B3
- F375 B3
- F376 B3
- F377 B3
- F378 B3
- F379 B3
- F380 B3
- F381 B3
- F382 B3
- F383 B3
- F384 B3
- F385 B3
- F386 B3
- F387 B3
- F388 B3
- F389 B3
- F390 B3
- F391 B3
- F392 B3
- F393 B3
- F394 B3
- F395 B3
- F396 B3
- F397 B3
- F398 B3
- F399 B3
- F400 B3
- F401 B3
- F402 B3
- F403 B3
- F404 B3
- F405 B3
- F406 B3
- F407 B3
- F408 B3
- F409 B3
- F410 B3
- F411 B3
- F412 B3
- F413 B3
- F414 B3
- F415 B3
- F416 B3
- F417 B3
- F418 B3
- F419 B3
- F420 B3
- F421 B3
- F422 B3
- F423 B3
- F424 B3
- F425 B3
- F426 B3
- F427 B3
- F428 B3
- F429 B3
- F430 B3
- F431 B3
- F432 B3
- F433 B3
- F434 B3
- F435 B3
- F436 B3
- F437 B3
- F438 B3
- F439 B3
- F440 B3
- F441 B3
- F442 B3
- F443 B3
- F444 B3
- F445 B3
- F446 B3
- F447 B3
- F448 B3
- F449 B3
- F450 B3
- F451 B3
- F452 B3
- F453 B3
- F454 B3
- F455 B3
- F456 B3
- F457 B3
- F458 B3
- F459 B3
- F460 B3
- F461 B3
- F462 B3
- F463 B3
- F464 B3
- F465 B3
- F466 B3
- F467 B3
- F468 B3
- F469 B3
- F470 B3
- F471 B3
- F472 B3
- F473 B3
- F474 B3
- F475 B3
- F476 B3
- F477 B3
- F478 B3
- F479 B3
- F480 B3
- F481 B3
- F482 B3
- F483 B3
- F484 B3
- F485 B3
- F486 B3
- F487 B3
- F488 B3
- F489 B3
- F490 B3
- F491 B3
- F492 B3
- F493 B3
- F494 B3
- F495 B3
- F496 B3
- F497 B3
- F498 B3
- F499 B3
- F500 B3

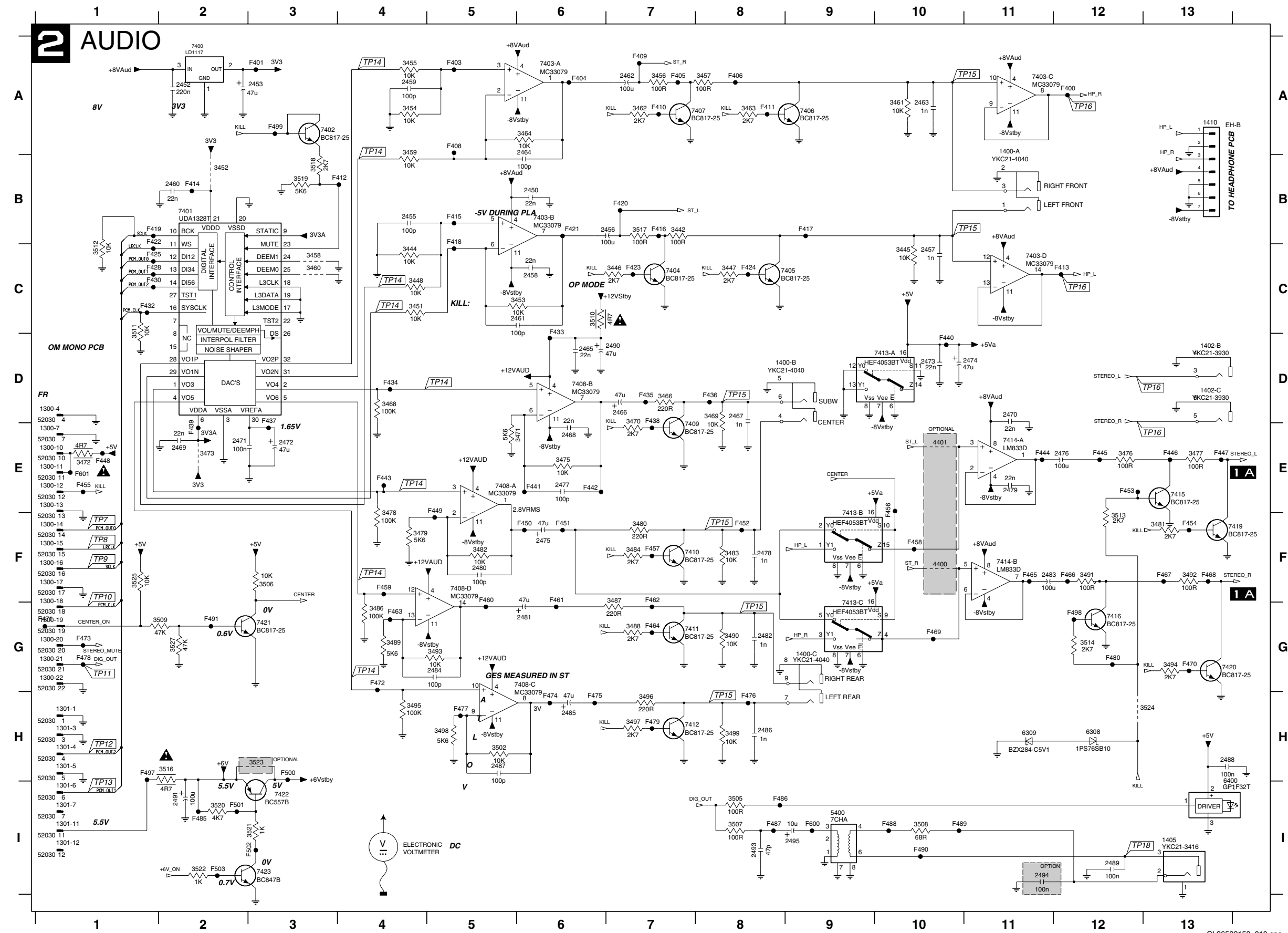

1300-10 E1	3494 G13	F459 F4
1300-11 E1	3495 H4	F460 F5
1300-12 E1	3496 H7	F461 F6
1300-13 E1	3497 H7	F462 F7
1300-14 F1	3498 H5	F463 G4
1300-15 F1	3499 H8	F464 G7
1300-16 F1	3502 H5	F465 F11
1300-17 F1	3505 I8	F466 F12
1300-18 G1	3506 F3	F467 F13
1300-19 G1	3507 I8	F468 F13
1300-20 G1	3508 I10	F469 G10
1300-21 G1	3509 G2	F470 G13
1300-22 G1	3510 C6	F471 G1
1300-4 D1	3511 C1	F472 G4
1300-7 E1	3512 C1	F473 G1
1301-1 H1	3513 F12	F474 H6
1301-11 H1	3514 G12	F475 H6
1301-12 H1	3516 H2	F476 H8
1301-3 H1	3517 B7	F477 H5
1301-4 H1	3518 B3	F478 G1
1301-5 H1	3519 B3	F479 H7
1301-6 H1	3520 I2	F480 G12
1301-7 H1	3521 I3	F481 G12
1400-A A11	3524 H1	F482 I8
1400-B D9	3523 H3	F487 I8
1400-C G9	3524 H13	F488 I10
1402-B D13	3525 F1	F489 I10
1402-C D13	3527 G2	F490 I10
1405 I13	4400 F10	F491 G2
1410 A13	4401 E10	F492 G7
2450 B6	5400 B6	F498 G12
2452 A2	6308 H12	F499 A3
2453 A3	6309 H11	F500 H3
2455 B4	6400 I13	F501 I2
2456 B7	7400 A2	F502 I3
2457 C10	7401 B2	F503 I2
2458 A3	7402 A3	F504 A3
2459 A4	7403-A A6	F505 A6
2460 B2	7403-B B6	F601 E1
2461 C6	7403-C A11	
2462 A7	7403-D C11	
2463 A10	7404 C7	
2464 A6	7405 C8	
2465 D6	7406 A9	
2466 D7	7407 A7	
2467 D8	7408-A E5	
2468 E6	7408-B D6	
2469 E2	7408-C G5	
2470 D11	7408-D F5	
2471 E2	7409 E7	
2472 E3	7410 F7	
2473 D10	7411 G7	
2474 D11	7412 H7	
2475 F6	7413-A D10	
2476 E12	7413-B F9	
2477 E6	7413-C G9	
2478 F8	7414-A E11	
2479 E11	7414-B F11	
2480 F13	7415 E13	
2481 G6	7416 G12	
2482 G8	7419 F13	
2483 F11	7420 G13	
2484 G5	7421 G3	
2485 H6	7422 I3	
2486 H8	7423 I3	
2487 H5	7424 A12	
2488 H13	F401 A3	
2489 I12	F403 A5	
2490 D7	F404 A6	
2491 I2	F405 A7	
2493 I8	F406 A8	
2494 H11	F408 A5	
2495 I9	F409 A7	
3442 B7	F410 A7	
3444 C4	F411 A8	
3445 C10	F412 B4	
3446 C7	F413 C12	
3447 C8	F414 B2	
3448 C4	F415 B5	
3451 C4	F416 B7	
3452 B2	F417 B9	
3453 C6	F418 B5	
3454 A4	F419 B1	
3455 A4	F420 B7	
3456 A7	F421 B6	
3457 A8	F422 B1	
3458 C3	F423 C7	
3459 B4	F424 C8	
3460 C3	F425 C1	
3461 A10	F426 C1	
3462 A7	F430 C1	
3463 A8	F432 C1	
3464 A6	F433 C6	
3465 D7	F434 D4	
3468 D4	F435 D7	
3469 D8	F436 D8	
3470 E7	F437 D3	
3471 E5	F438 D7	
3472 E1	F439 E2	
3473 E2	F440 D10	
3475 E6	F441 E6	
3476 E12	F442 E6	
3477 E13	F443 E4	
3478 E4	F444 E11	
3479 F4	F445 E12	
3480 F7	F446 E13	
3481 F13	F447 F13	
3482 F5	F448 F5	
3483 F8	F449 E5	
3484 F7	F450 F6	
3486 G4	F451 F6	
3487 G7	F452 F8	
3488 G7	F453 E12	
3489 G4	F454 F13	
3490 G8	F455 E1	
3491 F12	F456 E10	
3492 F13	F457 F7	
3493 G5	F458 F10	

