

SERVICEANLEITUNG

Service Manual. Manuel de Service. Manuale di Servizio.
Instrucciones de servicio. Service-instructies.

DVD Recorder

230- 90434.934

CENTROS 1202

Art.-Nr. 65501

CENTROS 1272

Art.-Nr. 65511



CENTROS 1202 / CENTROS 1272

LOEWE.

CONTENTS

SECTION 1 SUMMARY

SECTION 2 CABINET & MAIN CHASSIS

SECTION 3 ELECTRICAL

SECTION 4 PARTS LIST

SECTION 1

SUMMARY

CONTENTS

NEW FUNCTIONS OF DVD-RECORDER	1-2
PRODUCT SAFETY SERVICING GUIDELINES FOR VIDEO PRODUCTS.....	1-3
SERVICING PRECAUTIONS	1-4
• General Servicing Precautions	
• Insulation Checking Prodedure	
• Electrostatically Sensitive Devices	
SERVICE INFORMATION FOR EEPROM IC SETTING	1-5
SPECIFICATIONS	1-6

NEW FUNCTIONS OF DVD-RECORDER

• SUMMARY OF PRODUCT

- RECORDING FUNCTION OF DVD-RW AND DVD-R SPECIFICATIONS
 - DVD-RW: VIDEO MODE AND VR MODE RECORD AVAILABLE
 - DVD-R :VIDEO MODE RECORD AVAILABLE
- DIGITAL DUBBING FUNCTION OF DV CAMCORDER BY USING DV TERMINAL (IEEE1394)
 - RECORD, PLAY, FF/REW FUNCTION BY REMOTE CONTROL OF DV CAMCORDER
- DVD PROGRESSIVE PLAY RESPONSE
- VARIOUS FUNCTION RESPONSE OF DVD RECORDING (DISC NAVIGATION AND CONVENIENT PLAY, EDIT FUNCTION)
- OUTSIDE INPUT AND TV RECORDING AVAILABLE
 - RECORDING SCREEN QUALITY :VR(HQ, SQ, LQ), VIDEO(HQ, SQ)
- TV RESERVE RECORDING FUNCTION (AUTO MODE SETTING AVAILABLE FOR RECORDING IN ACCORDANCE WITH THE REMAINING DISC SPACE IN RESERVATION)

SUMMARIZED EXPLANATION OF MAIN FUNCTION

- DVD RECORDING FUNCTION(VR MODE RECORD / VIDEO MODE RECORD)
 - 1) VR MODE RECORD : MANUAL MODE RECORDING IN ACCORDANCE WITH VARIOUS EDITING FUNCTION, REMAINING DISC SPACE AND PROGRAM TIME DVD-RW DISC RECORDED IN THE VR MODE CAN BE PLAYED WITH A DVD PLAYER CORRESPONDING TO THE DVD-RW THERE IS ALSO A PLAYER TO BE PLAYED THROUGH FINALIZING. FOR THE DVD-RW, RECORDING AND EDITING IS AVAILABLE AT THE SAME DEVICE EVEN AFTER FINALIZING.
 - 2) VIDEO MODE RECORDING : THERE IS NO EDITING FUNCTION SUCH AS VR MODE RECORDING BUT VIDEO MODE RECORDING IS PLAYED IN A GAME DEVICE (FOR EXAMPLE, "PLAY STATION 2") WITH PC, DVD PLAY FUNCTION CORRESPONDING TO DVD PLAYER, CAR DVD, DVD-ROM. TO PLAY IN ANOTHER DEVICE, FINALIZING IS REQUIRED. RECORDING, EDITING AND EDITING IS NOT POSSIBLE AFTER FINALIZING. HOWEVER, RECORDING IS ALLOWED AT THE DVD-RW DISC IF ERASING THE TITLE FINALLY RECORDED AFTER FINALIZING.
 - 3) RECORDING MODE INITIALIZATION (A KIND OF FORMATTING): BEGINS INITIALIZATION AFTER SELECTING RECORDING MODE AS VR OR VIDEO MODE BY USING INITIALIZATION FUNCTION OF THE DISC SETTING MENU. INITIALIZES DEFAULT AS VR MODE FOR DVD-RW. RECORDS IT AS VIDEO MODE WITHOUT INITIALIZATION FOR VIDEO MODE.
 - 4) FINALIZE: BEGINS FINALIZE AT THE DISC SETTING MENU DURING STOP.

PRODUCT SAFETY SERVICING GUIDELINES FOR VIDEO PRODUCTS

IMPORTANT SAFETY NOTICE

This manual was prepared for use only by properly trained audio-video service technicians.

When servicing this product, under no circumstances should the original design be modified or altered without permission from LOEWE Electronics Corporation. All components should be replaced only with types identical to those in the original circuit and their physical location, wiring and lead dress must conform to original layout upon completion of repairs.

Special components are also used to prevent x-radiation, shock and fire hazard. These components are indicated by the letter "x" included in their component designators and are required to maintain safe performance. No deviations are allowed without prior approval by LOEWE Electronics Corporation.

Circuit diagrams may occasionally differ from the actual circuit used. This way, implementation of the latest safety and performance improvement changes into the set is not delayed until the new service literature is printed.

CAUTION: Do not attempt to modify this product in any way. Never perform customized installations without manufacturer's approval. Unauthorized modifications will not only void the warranty, but may lead to property damage or user injury.

Service work should be performed only after you are thoroughly familiar with these safety checks and servicing guidelines.

GRAPHIC SYMBOLS



The exclamation point within an equilateral triangle is intended to alert the service personnel to important safety information in the service literature.



The lightning flash with arrowhead symbol within an equilateral triangle is intended to alert the service personnel to the presence of noninsulated "dangerous voltage" that may be of sufficient magnitude to constitute a risk of electric shock.



The pictorial representation of a fuse and its rating within an equilateral triangle is intended to convey to the service personnel the following fuse replacement caution notice:

CAUTION: FOR CONTINUED PROTECTION AGAINST RISK OF FIRE, REPLACE ALL FUSES WITH THE SAME TYPE AND RATING AS MARKED NEAR EACH FUSE.

SERVICE INFORMATION

While servicing, use an isolation transformer for protection from AC line shock. After the original service problem has been corrected, make a check of the following:

FIRE AND SHOCK HAZARD

1. Be sure that all components are positioned to avoid a possibility of adjacent component shorts. This is especially important on items transported to and from the repair shop.
2. Verify that all protective devices such as insulators, barriers, covers, shields, strain reliefs, power supply cords, and other hardware have been reinstalled per the original design. Be sure that the safety purpose of the polarized line plug has not been defeated.
3. Soldering must be inspected to discover possible cold solder joints, solder splashes, or sharp solder points. Be certain to remove all loose foreign particles.
4. Check for physical evidence of damage or deterioration to parts and components, for frayed leads or damaged insulation (including the AC cord), and replace if necessary.
5. No lead or component should touch a high current device or a resistor rated at 1 watt or more. Lead tension around protruding metal surfaces must be avoided.
6. After reassembly of the set, always perform an AC leakage test on all exposed metallic parts of the cabinet (the channel selector knobs, antenna terminals, handle and screws) to be sure that set is safe to operate without danger of electrical shock. **DO NOT USE A LINE ISOLATION TRANSFORMER DURING THIS TEST.** Use an AC voltmeter having 5000 ohms per volt or more sensitivity in the following manner: Connect a 1500 ohm, 10 watt resistor, paralleled by a .15 mfd 150V AC type capacitor between a known good earth ground water pipe, conduit, etc.) and the exposed metallic parts, one at a time. Measure the AC voltage across the combination of 1500 ohm resistor and .15 mfd capacitor. Reverse the AC plug by using a non-polarized adaptor and repeat AC voltage measurements for each exposed metallic part. Voltage measured must not exceed 0.75 volts RMS. This corresponds to 0.5 milliamp AC. Any value exceeding this limit constitutes a potential shock hazard and must be corrected immediately.

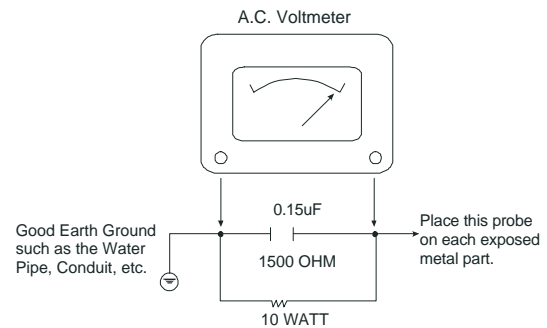

TIPS ON PROPER INSTALLATION

1. Never install any receiver in a closed-in recess, cubbyhole, or closely fitting shelf space over, or close to, a heat duct, or in the path of heated air flow.
2. Avoid conditions of high humidity such as: outdoor patio installations where dew is a factor, near steam radiators where steam leakage is a factor, etc.
3. Avoid placement where draperies may obstruct venting. The customer should also avoid the use of decorative scarves or other coverings that might obstruct ventilation.
4. Wall- and shelf-mounted installations using a commercial mounting kit must follow the factory-approved mounting instructions. A product mounted to a shelf or platform must retain its original feet (or the equivalent thickness in spacers) to provide adequate air flow across the bottom. Bolts or screws used for fasteners must not touch any parts or wiring. Perform leakage tests on customized installations.
5. Caution customers against mounting a product on a sloping shelf or in a tilted position, unless the receiver is properly secured.
6. A product on a roll-about cart should be stable in its mounting to the cart. Caution the customer on the hazards of trying to roll a cart with small casters across thresholds or deep pile carpets.
7. Caution customers against using extension cords. Explain that a forest of extensions, sprouting from a single outlet, can lead to disastrous consequences to home and family.

SERVICING PRECAUTIONS

CAUTION : Before servicing the DVD Recorder covered by this service data and its supplements and addends, read and follow the **SAFETY PRECAUTIONS**. **NOTE** : if unforeseen circumstances create conflict between the following servicing precautions and any of the safety precautions in this publications, always follow the safety precautions.

Remembers Safety First:

General Servicing Precautions

1. Always unplug the DVD Recorder AC power cord from the AC power source before:
 - (1) Removing or reinstalling any component, circuit board, module, or any other assembly.
 - (2) Disconnection or reconnecting any internal electrical plug or other electrical connection.
 - (3) Connecting a test substitute in parallel with an electrolytic capacitor.
Caution : A wrong part substitution or incorrect polarity installation of electrolytic capacitors may result in an explosion hazard.
2. Do not spray chemicals on or near this DVD Recorder or any of its assemblies.
3. Unless specified otherwise in this service data, clean electrical contacts by applying an appropriate contact cleaning solution to the contacts with a pipe cleaner, cotton-tipped swab, or comparable soft applicator. Unless specified otherwise in this service data, lubrication of contacts is not required.
4. Do not defeat any plug/socket B+ voltage interlocks with which instruments covered by this service manual might be equipped.
5. Do not apply AC power to this DVD Recorder and/or any of its electrical assemblies unless all solid-state device heat sinks are correctly installed.
6. Always connect test instrument ground lead to the appropriate ground before connection the test instrument positive lead. Always remove the test instrument ground lead last.

Insulation Checking Procedure

Disconnect the attachment plug from the AC outlet and turn the power on. Connect an insulation resistance meter(500V) to the blades of the attachment plug. The insulation resistance between each blade of the attachment plug and accessible conductive parts (Note 1) should be more than 1M-ohm.

Note 1 : Accessible Conductive Parts including Metal panels, Input terminals, Earphone jacks, etc.

Electrostatically Sensitive (ES) Devices

Some semiconductor (solid state) devices can be damaged easily by static electricity. Such components commonly are called Electrostatically Sensitive (ES) Devices. Examples of typical ES devices are integrated circuits and some field effect transistors and semiconductor chip components.

The following techniques should be used to help reduce the incidence of component damage caused by static electricity.

1. Immediately before handling any semiconductor component or semiconductor-equipped assembly, drain off any electrostatic charge on your body by touching a known earth ground. Alternatively, obtain and wear a commercially available discharging wrist strap device, which should be removed for potential shock reasons prior to applying power to the unit under test.
2. After removing an electrical assembly equipped with ES devices, place the assembly on a conductive surface such as aluminum foil, to prevent electrostatic charge buildup or exposure of the assembly.
3. Use only a grounded-tip soldering iron to solder or unsolder ES devices.
4. Use only an anti-static solder removal device. Some solder removal devices not classified a "anti-static" can generate electrical charges sufficient to damage ES devices.
5. Do not use freon-propelled chemicals. These can generate electrical charge sufficient to damage ES devices.
6. Do not remove a replacement ES device from its protective package until immediately before you are ready to install it. (Most replacement ES devices are packaged with leads electrically shorted together by conductive foam, aluminum foil, or comparable conductive material).
7. Immediately before removing the protective material from the leads of a replacement ES device, touch the protective material to the chassis or circuit assembly into which the device will be installed.

Caution : Be sure no power is applied to the chassis or circuit, and observe all other safety precautions.

8. Minimize bodily motions when handling unpackaged replacement ES devices. (Normally harmless motion such as the brushing together of your clothes fabric or the lifting of your foot from a carpeted floor can generate static electricity sufficient to damage an ES device.)

SERVICE INFORMATION FOR EEPROM IC SETTING

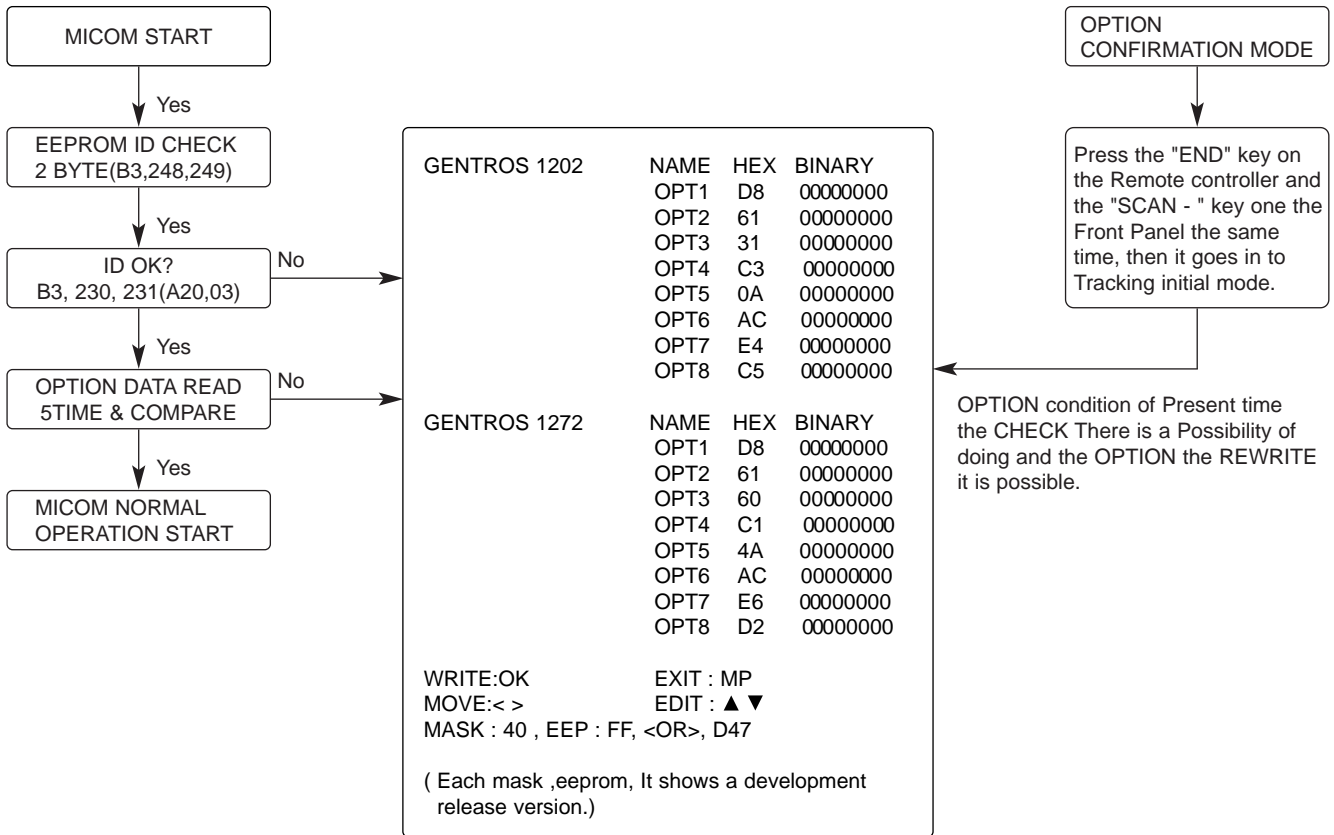

*** EEPROM INITIAL ***

- SETUP is displayed in the field if pressing the Front "SCAN-" Key with the Remocon "END" key pressed in the status of powering on.
- AUTO SEARCH is done since the initial screen of ACMS is serviced if powering on.

SPECIFICATIONS

• GENERAL

Power requirements	AC 200-240V, 50/60 Hz
Power consumption	44W
Dimensions (approx.) (approx.)	430 X 92 X 382.5 mm (16.9 x 3.6 x 15 inches) (w x h x d) Mass 6.4 kg (14.1 lbs)
Operating temperature	5°C to 35°C (41°F to 95°F)
Operating humidity	5 % to 90 %
Television system	PAL B/G colour system
Recording format	PAL

• RECORDING

Recording format	DVD VideoRecording, DVD-VIDEO
Recordable discs	DVD-ReRecordable, DVD-Recordable
Recordable time	Approx. 1 hour (HQ mode), 2 hours (SQ mode), 4 hours (LQ mode)

Video recording format

Sampling frequency	27MHz
Compression format	MPEG 2

Audio recording format

Sampling frequency	48kHz
Compression format	Dolby Digital

• DVD SPECIFICATIONS

Laser system	Semiconductor laser
Frequency response	DVD (PCM 48 kHz): 8 Hz to 22 kHz, CD: 8 Hz to 20 kHz
Signal-to-noise ratio	More than 100 dB
Harmonic distortion	Less than 0.008%
Dynamic range	More than 95 dB

• INPUTS

AERIAL IN	Aerial input, 75 ohms
VIDEO IN	1.0 Vp-p 75 ohms, sync negative, RCA jack x 2 / SCART
AUDIO IN	0 dBm more than 47 kohms, RCA jack (L, R) x 2 / SCART
DV IN	4 pin (i.LINK/IEEE 1394 standard)

• OUTPUTS

VIDEO OUT	1 Vp-p 75 Ω, sync negative, RCA jack x 1
S-VIDEO OUT	(Y) 1.0 V (p-p), 75 Ω, negative sync, Mini DIN 4-pin x 1 (C) 0.3 V (p-p) 75 Ω
COMPONENT VIDEO OUT	(Y) 1.0 V (p-p), 75 Ω, negative sync, RCA jack x 1 (Pb)/(Pr) 0.7 V (p-p), 75 Ω, RCA jack x 2
Audio output (digital audio)	0.5 V (p-p), 75 Ω, RCA jack x 1
Audio output (optical audio)	5 V (p-p), 75 Ω, Optical connector x 1
Audio output (analog audio)	2.0 Vrms (1 KHz, 0 dB), 600 Ω, RCA jack (L, R) x 1 / SCART

• ACCESSORY:

Video cable	1	Audio cable	1
RF Coaxial Cable.....	1	Blank DVD-R disc2
Remote control	1	Batteries2

SECTION 2
CABINET & MAIN CHASSIS

CONTENTS

EXPLODED VIEWS2-2

- 1. Cabinet and Main Frame Section2-2**
- 2. Deck Mechanism Section(MTK)2-3**

EXPLODED VIEWS

1. Cabinet and Main Frame Section

NOTES) ⚠ Warning
Parts that are shaded are critical
With respect to risk of fire or
electrical shock.

5
4
3
2
1

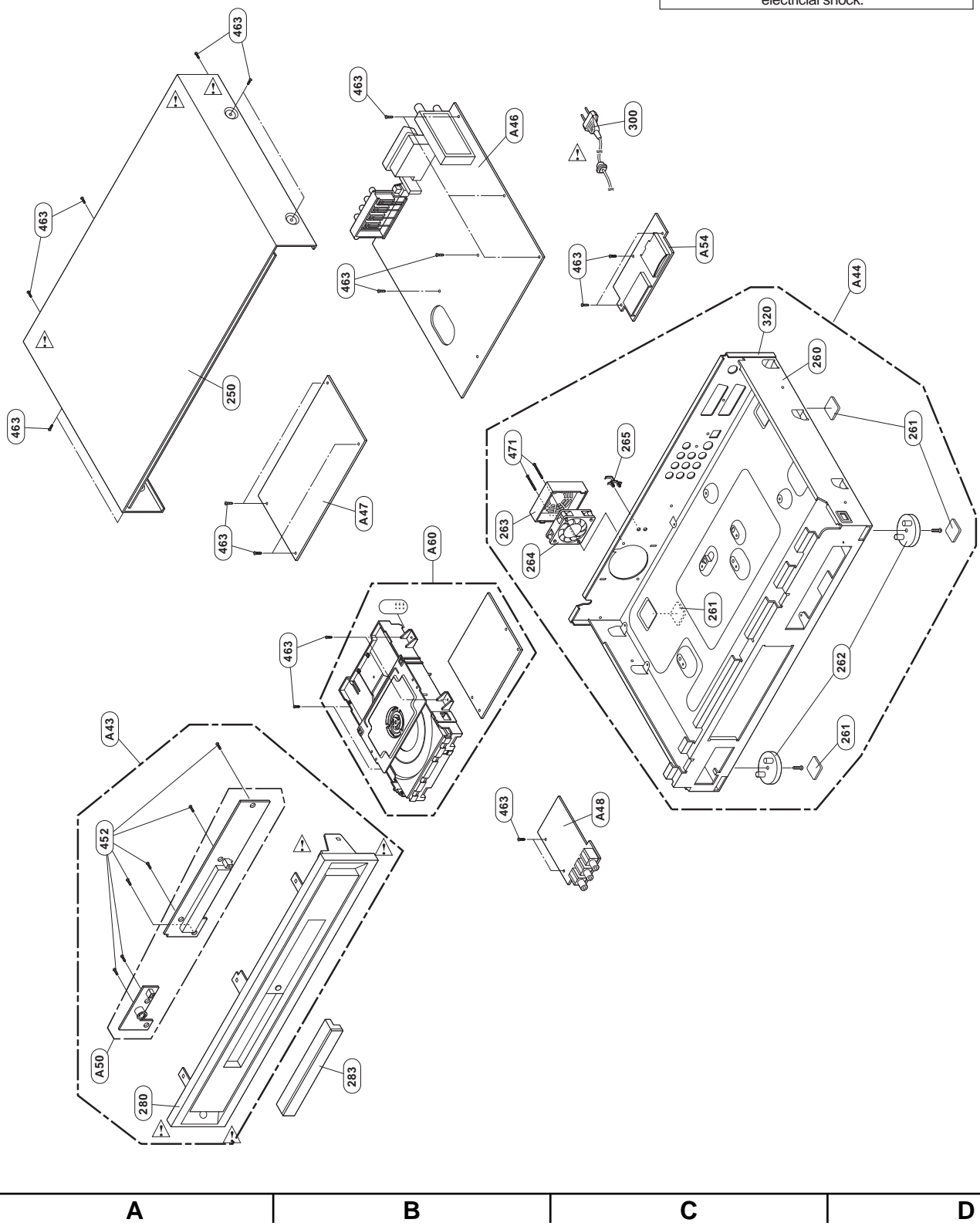

2. DECK MECHANISM SECTION(MTK)

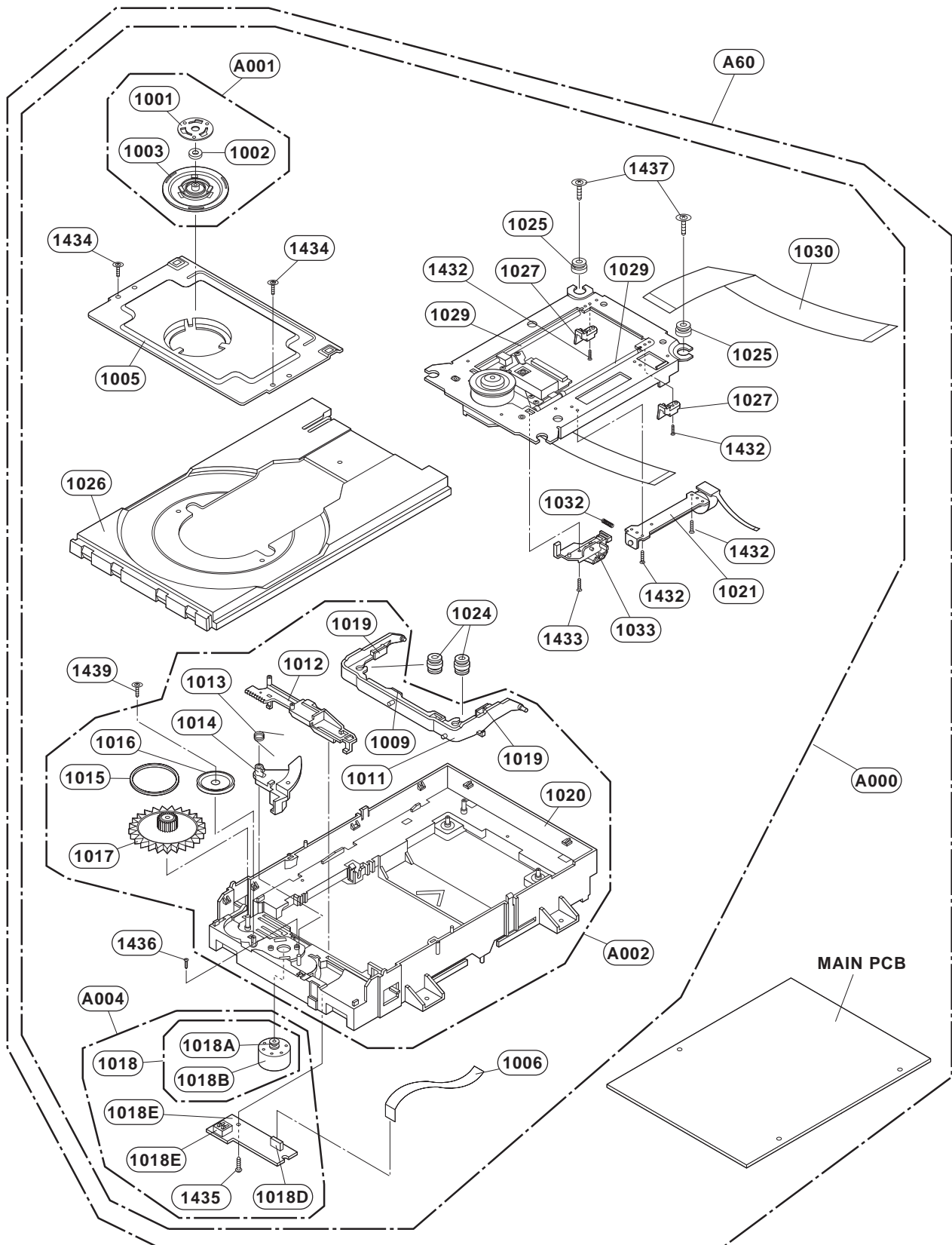

SECTION 3 ELECTRICAL CONTENTS

VDR PART

ELECTRICAL TROUBLESHOOTING GUIDE	3-2
BLOCK DIAGRAMS	3-18
1. POWER(SMPS) BLOCK DIAGRAM	3-18
2. VIDEO BLOCK DIAGRAM_PAL	3-20
3. AUDIO BLOCK DIAGRAM PAL	3-22
CIRCUIT DIAGRAMS	3-24
1. POWER CIRCUIT DIAGRAM	3-24
2. I/O MICOM CIRCUIT DIAGRAM	3-26
3. TUNER/MPX/ADC/DAC/JACK CIRCUIT DIAGRAM	3-28
4. HDMI CIRCUIT DIAGRAM	3-30
5. MPEG CIRCUIT DIAGRAM	3-32
6. TIMER/KEY CIRCUIT DIAGRAM	3-34
7. FRONT AV JACK CIRCUIT DIAGRAM	3-36
8. FRONT AV JACK_DV+SUPER CIRCUIT DIAGRAM	3-38
• CIRCUIT VOLTAGE CHART	3-40
PRINTED CIRCUIT DIAGRAMS	3-44
1. MAIN P.C.BOARD(TOP SIDE)	3-44
2. MAIN P.C.BOARD(BOTTOM SIDE)	3-46
3. JACK P.C.BOARD	3-48
4. FRONT P.C.BOARD	3-48
5. KEY TIMER P.C.BOARD	3-50
6. POWER P.C.BOARD	3-50

MTK LOADER PART

ELECTRICAL TROUBLESHOOTING GUIDE	3-52
BLOCK DIAGRAMS & DESCRIPTION	3-66
1. SERVO SYSTEM BLOCK DIAGRAM	3-66
2. MT1816 BLOCK DIAGRAM	3-67
3. MT1818 BLOCK DIAGRAM	3-68
CIRCUIT DIAGRAMS	3-69
1. RF CIRCUIT DIAGRAM	3-69
2. DSP CIRCUIT DIAGRAM	3-71
PRINTED CIRCUIT DIAGRAMS	3-73
1. MAIN P.C.BOARD(TOP SIDE)	3-73

VDR PART

ELECTRICAL TROUBLESHOOTING GUIDE

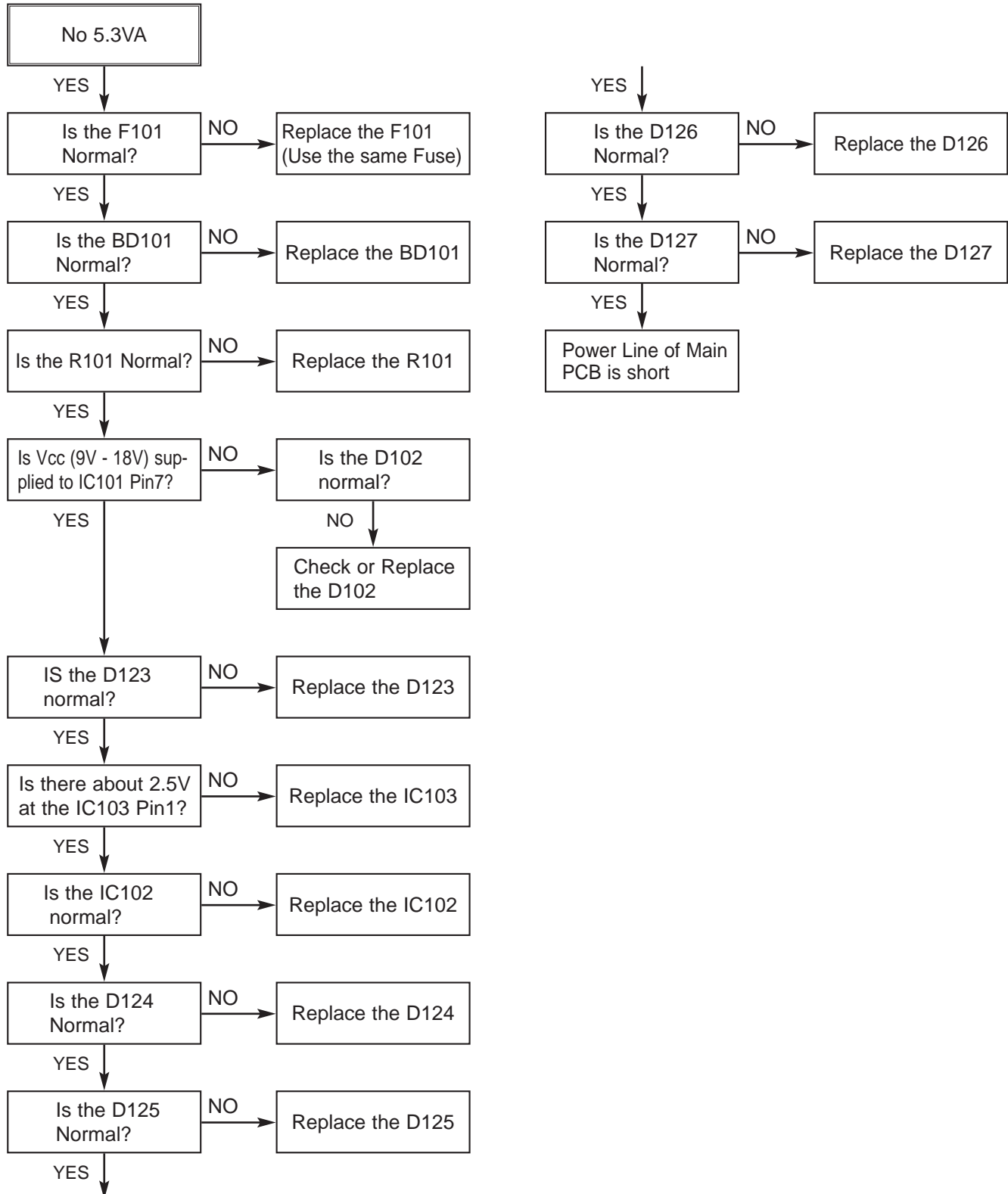

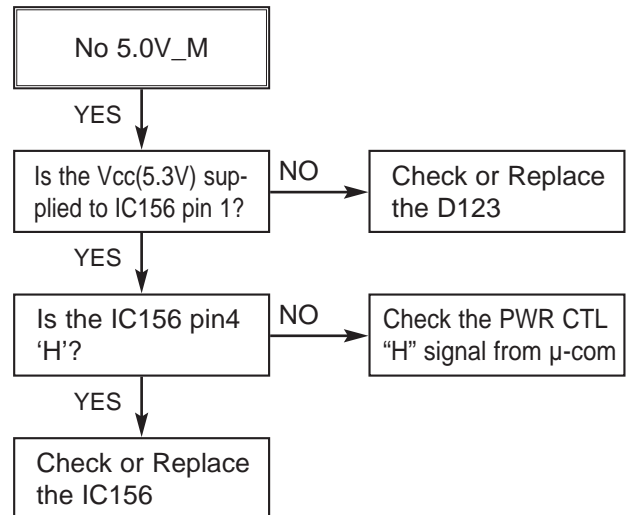
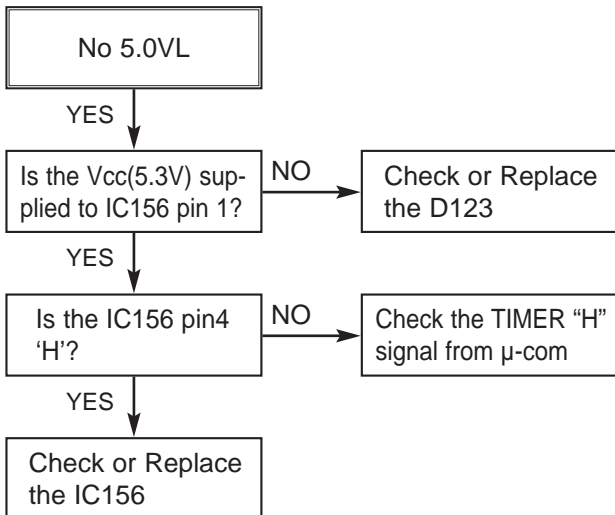
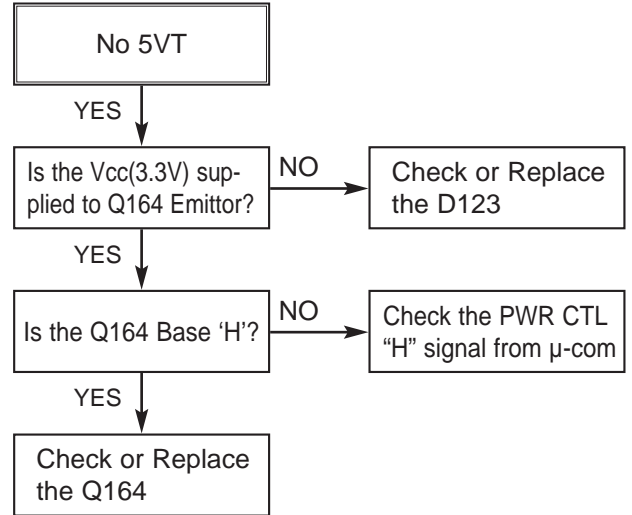
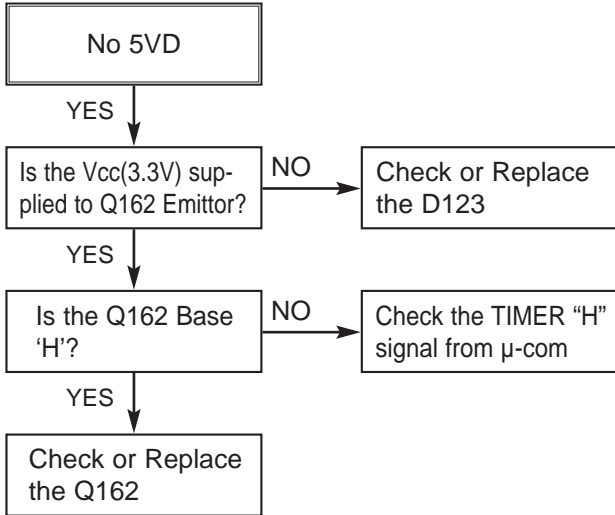

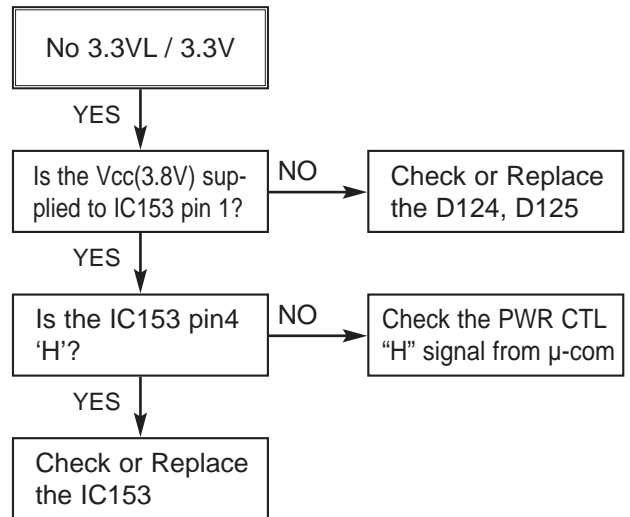
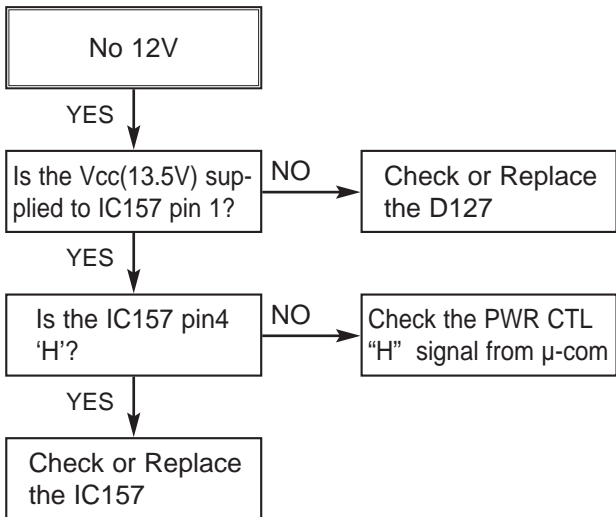
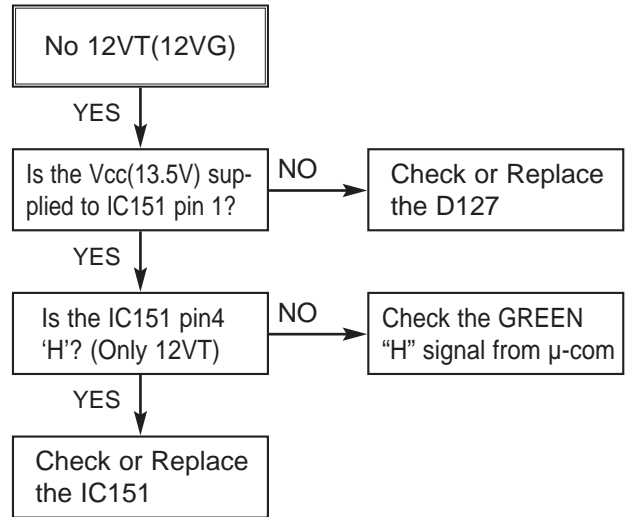
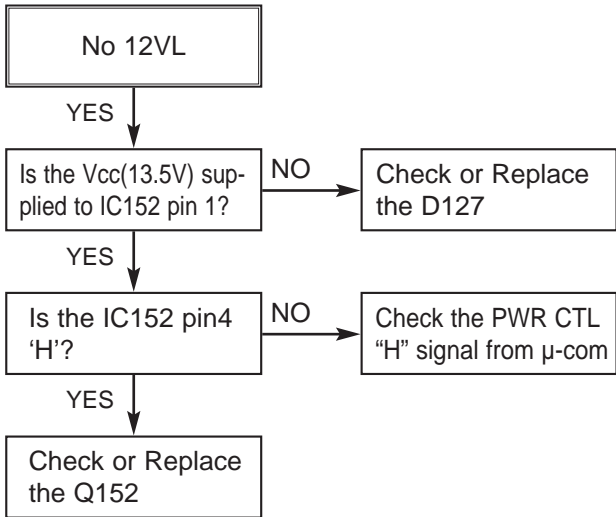

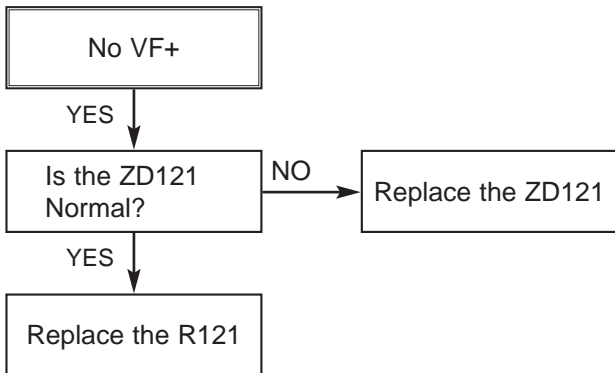
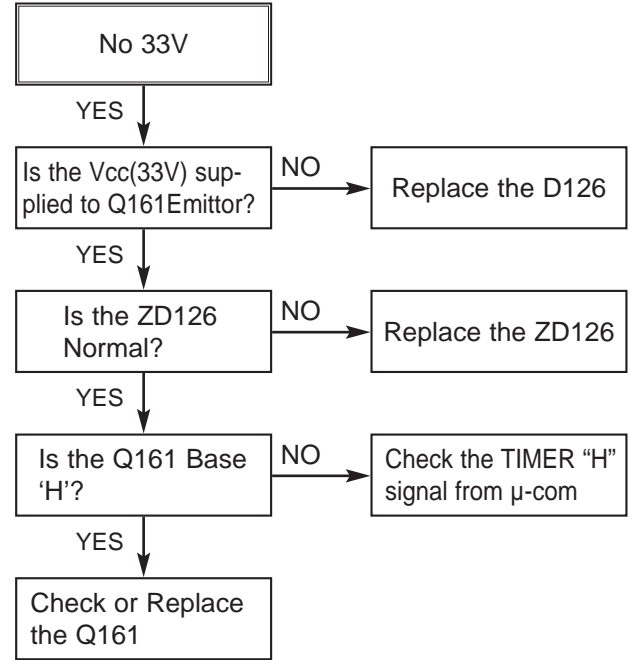
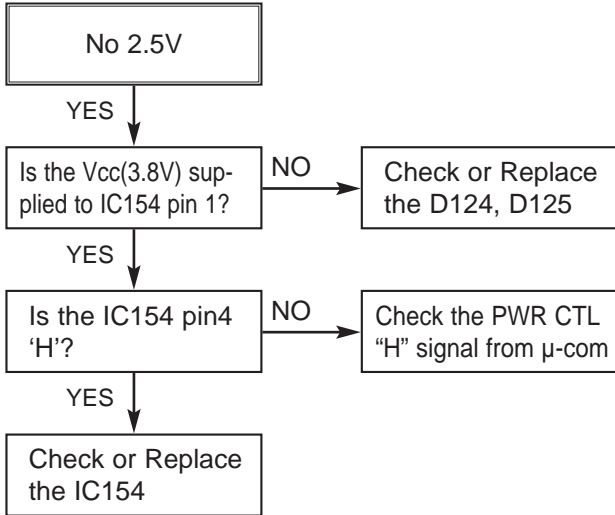

SYSTEM Section

LOEWE logo not displayed at
POWER ON

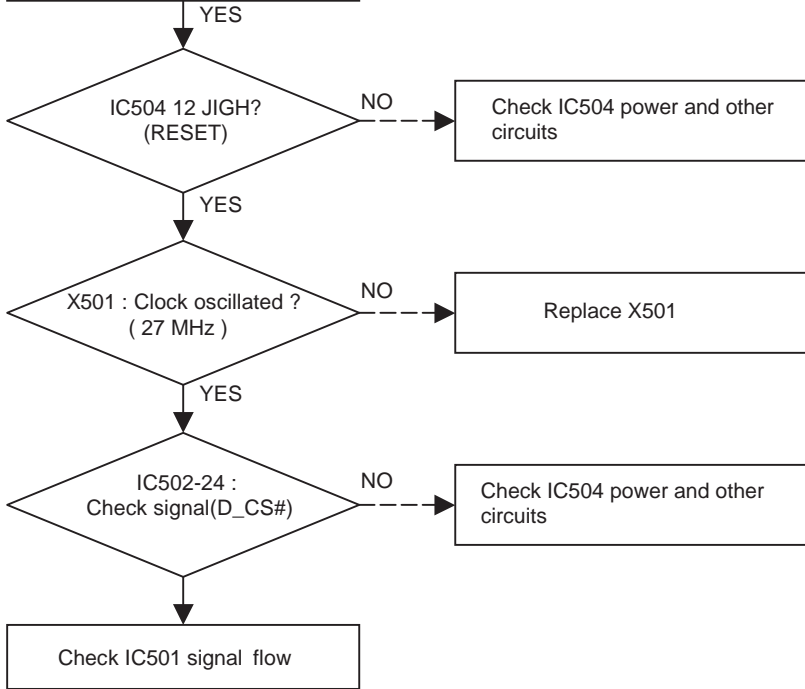

DISC not recognized

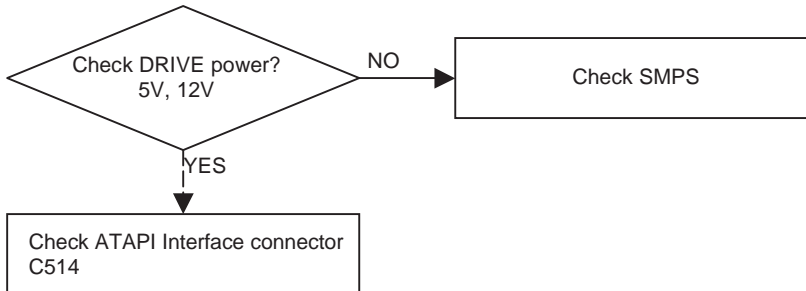

When playing DISC, no audio output

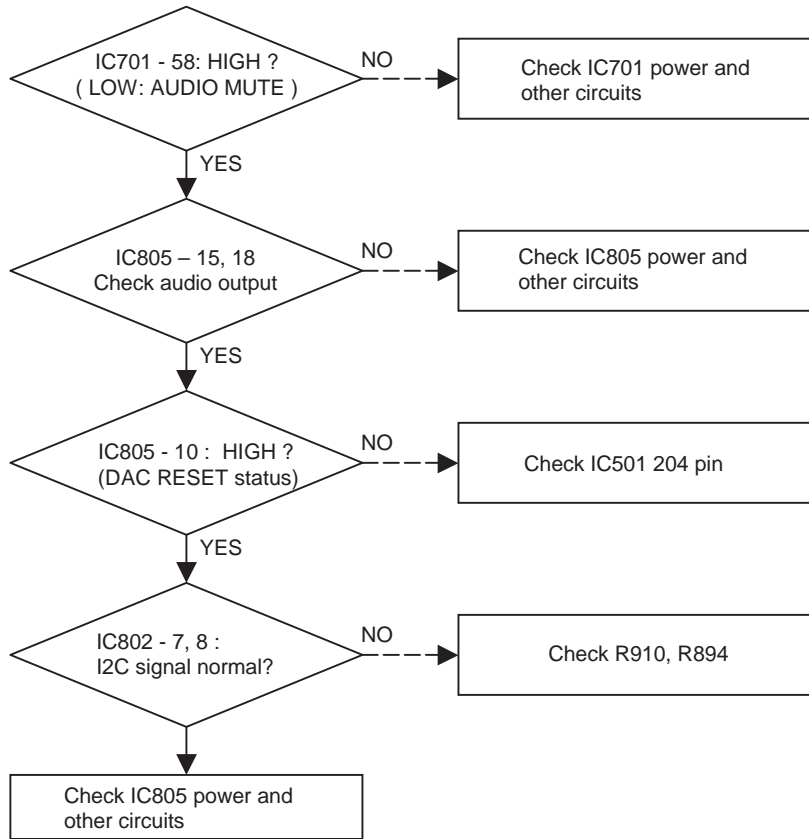

No OPTICAL / DIGITAL output

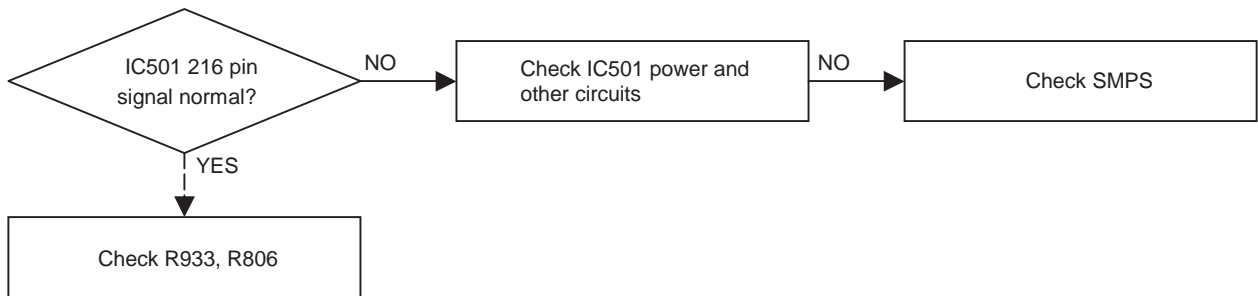

No TUNER audio output

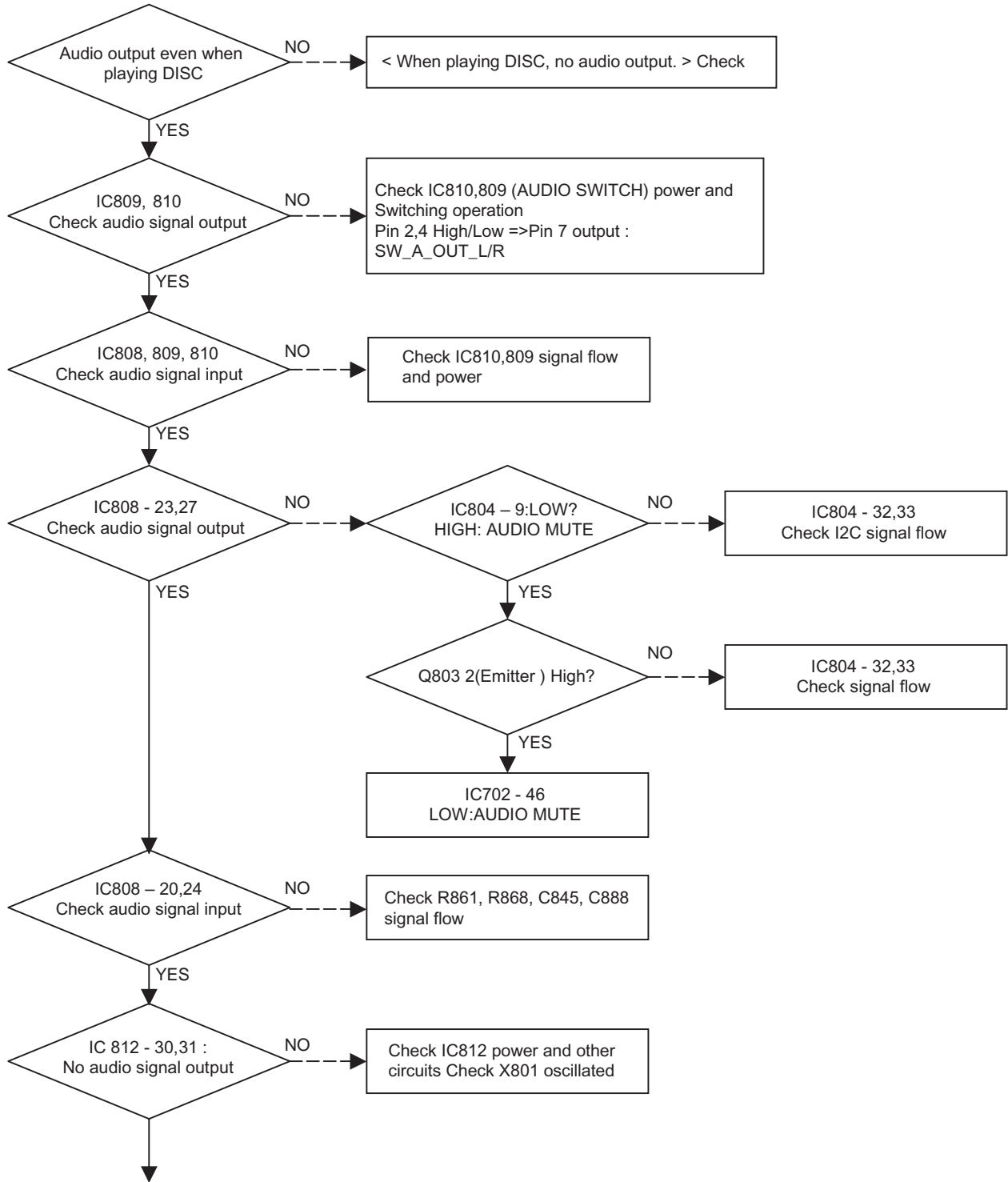

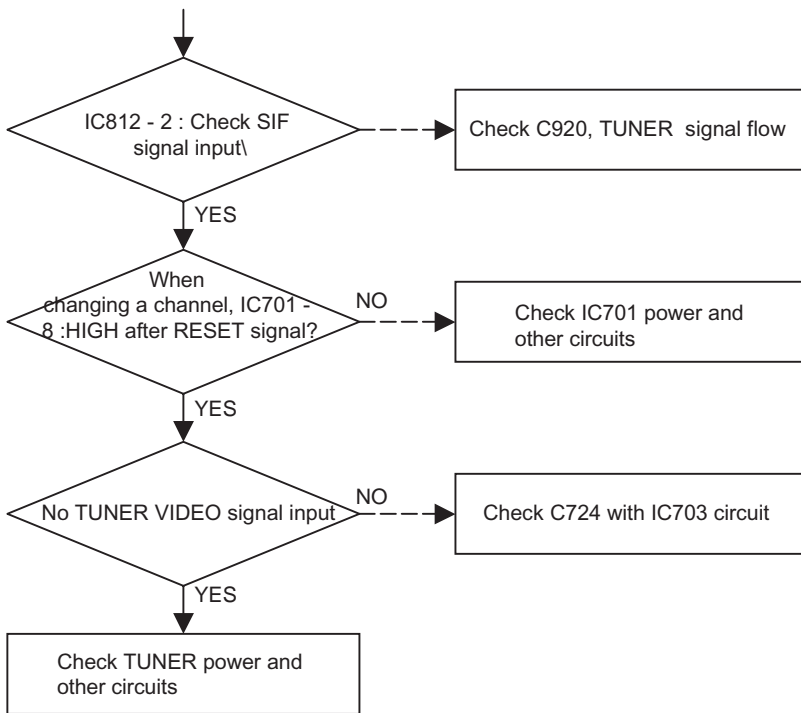

No external input 1 audio

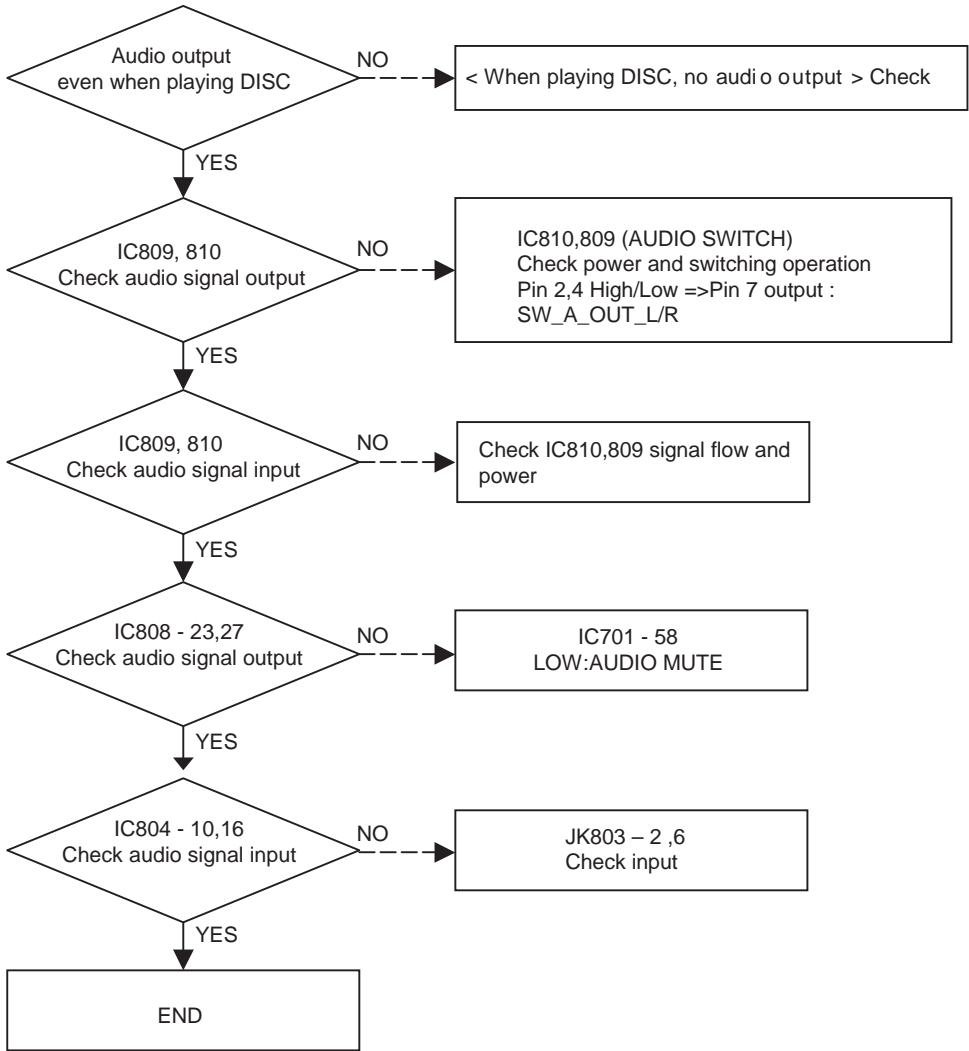

No external input 2 audio

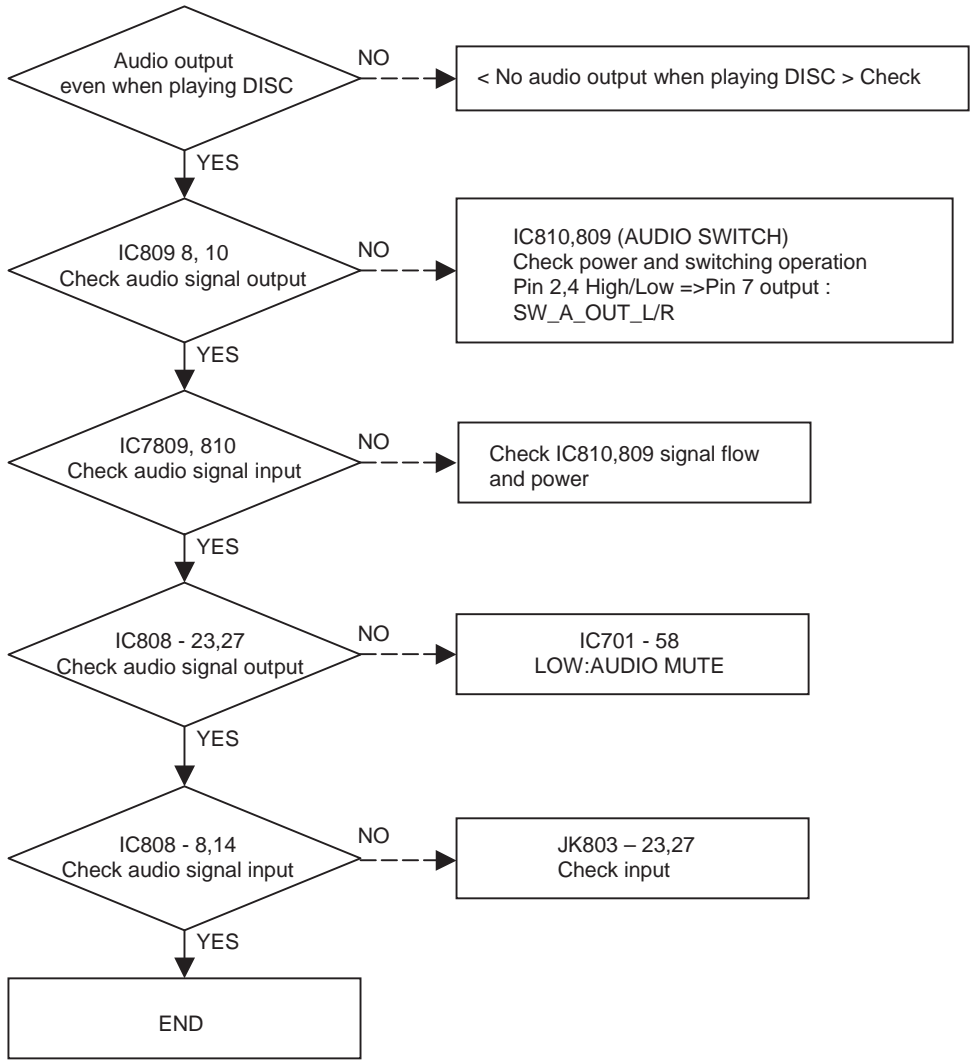

No external input 3 audio

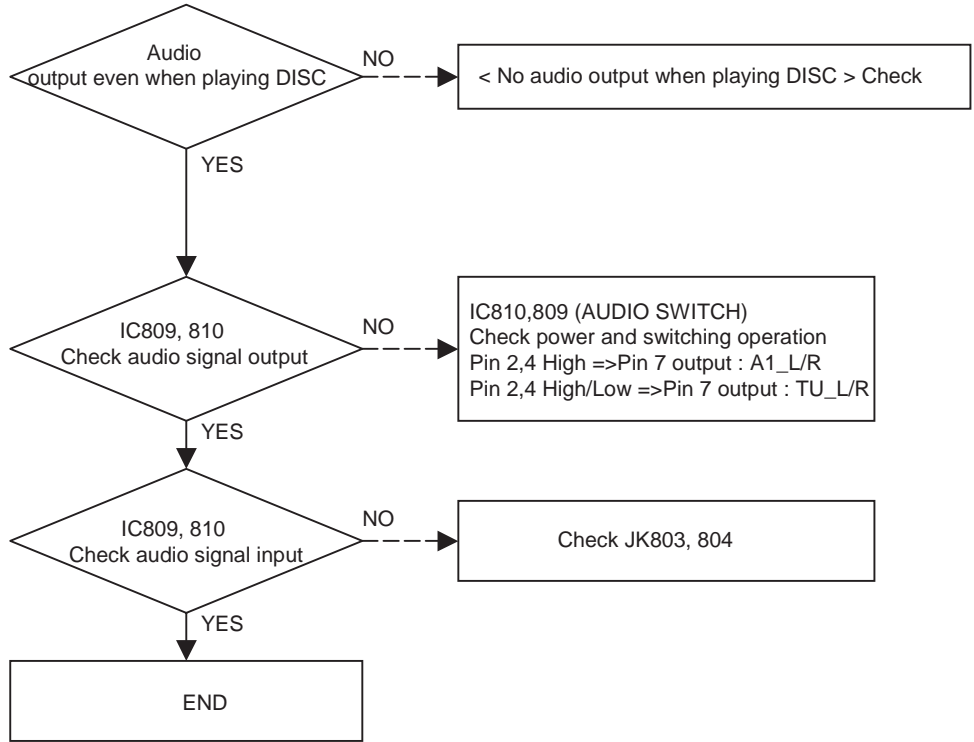

No external input 4 audio

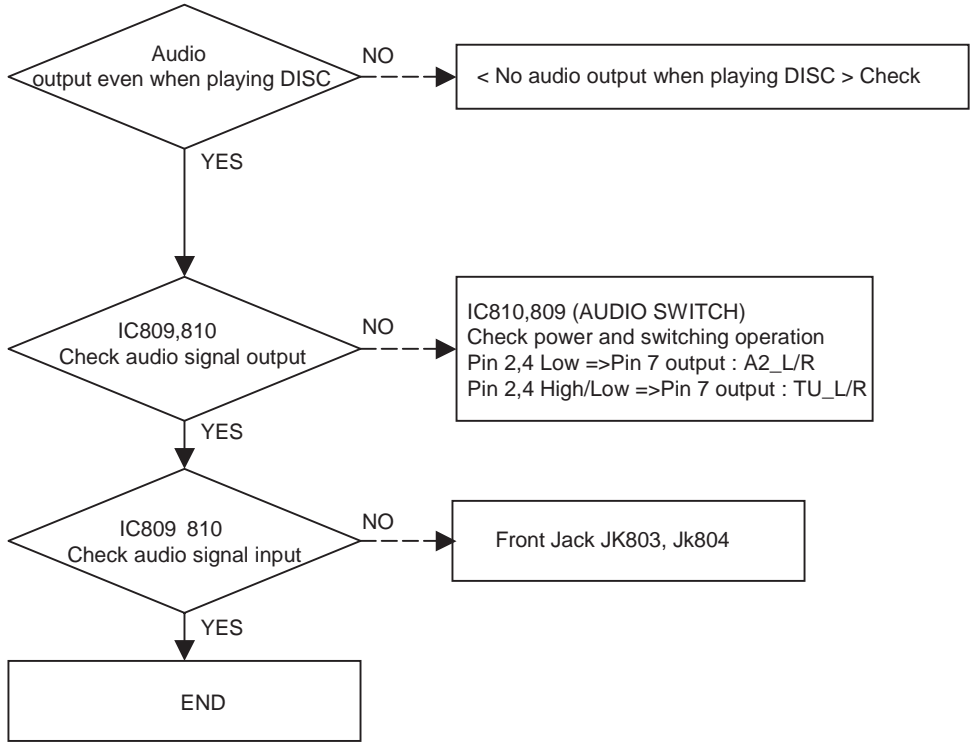

No RGB /
Component video signal when playing DISC

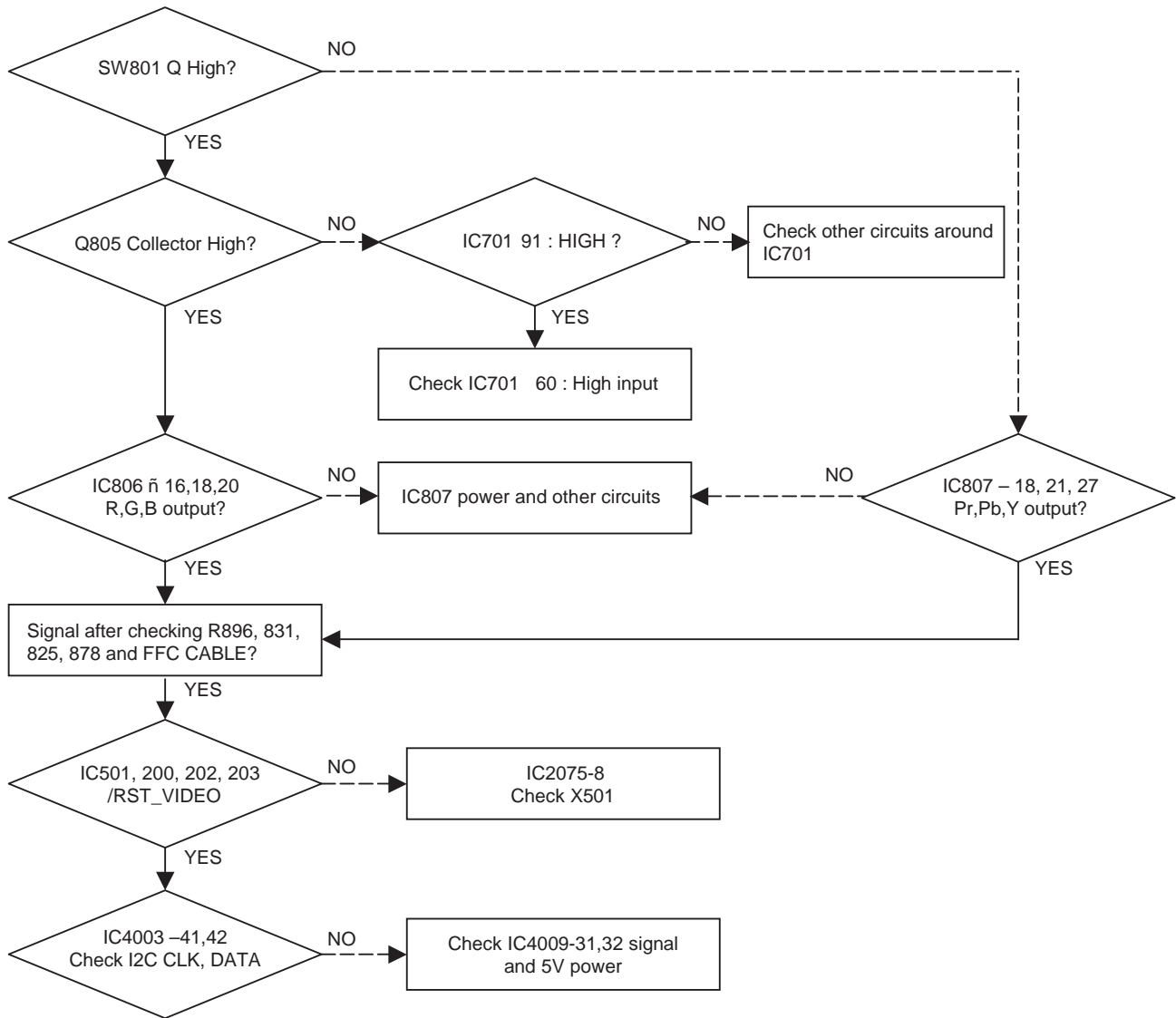

No COMPOSIT / S-VIDEO signal when playing DISC

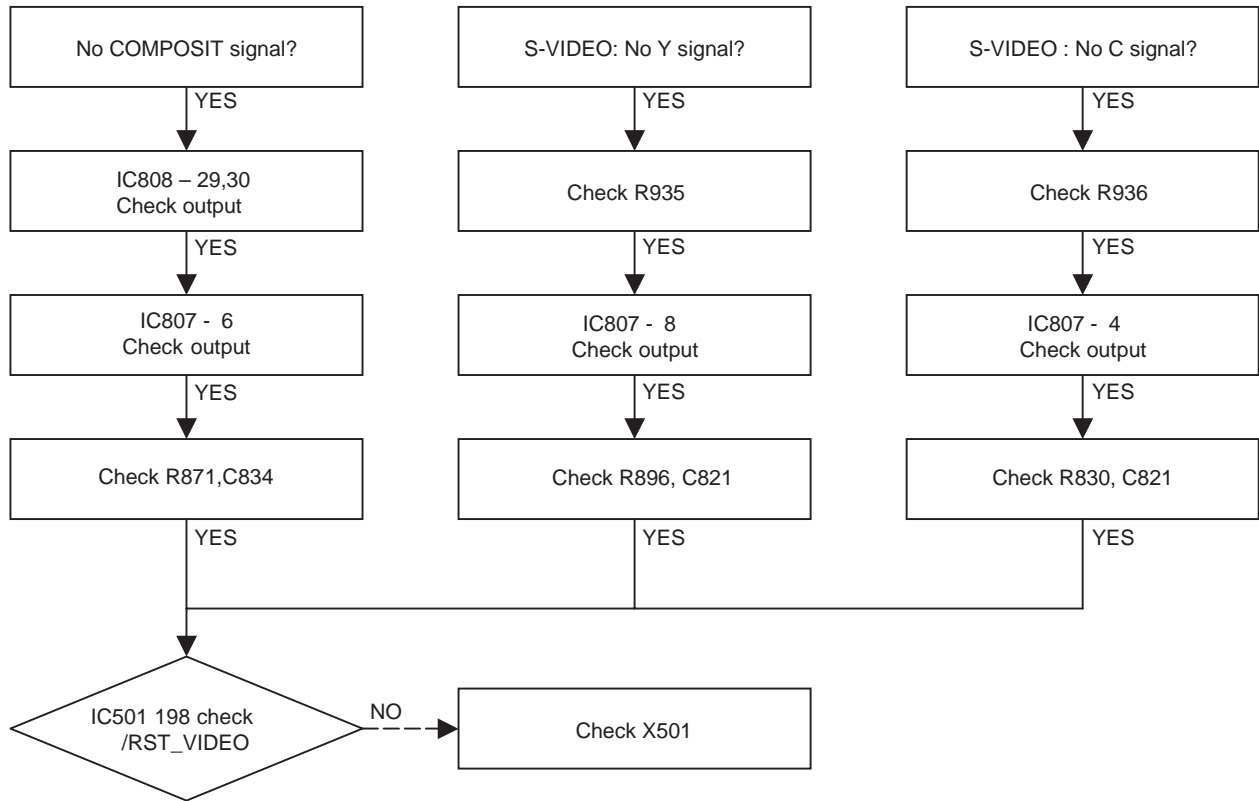

No TV , external input video signal

When connecting Tuner,
no TV video signal

YES

Check Tuner power and other
circuits

YES

Check IC808 - 28 (input) and
31 (output)

YES

IC831, 7(output)

NO

Check IC831, 6

YES

IC501, 256

NO

Check X501, power

YES

< When playing DISC, no COMPONENT, COMPOSIT/S-VIDEO signal > Check

No video signal of external input 1/2
(Rear Comosite input)

YES

Check IC808 - 1,3(input) and 31
(output).

YES

No video signal of external input 3/4
(Front S-VIDEDO / Comosite input)

YES

IC501 246, 248
Check signal input

YES

No DV(IEEE 1394) input (video/audio) signal

Check DV_JACK and CABLE connection

YES

IC507 - 27, 28, 29, 30
Check signal input

YES

IC507 -37 : HIGH?
(/RST_PHY)

NO

Check L509 Voltage

YES

Check IC507 - 2 Clock?
BIO_PHY_CLK

NO

Check X503 Clock
24.576 MHz

YES

IC3048 => IC1099
Check BIO_PHY_DATA/CLK
signal

NO

Check IC507 power and
other circuits

YES

< When playing DISC, No COMPONENT, COMPOSIT/S-VIDEO signal > Check

BLOCK DIAGRAMS

1. POWER(SMPS) BLOCK DIAGRAM

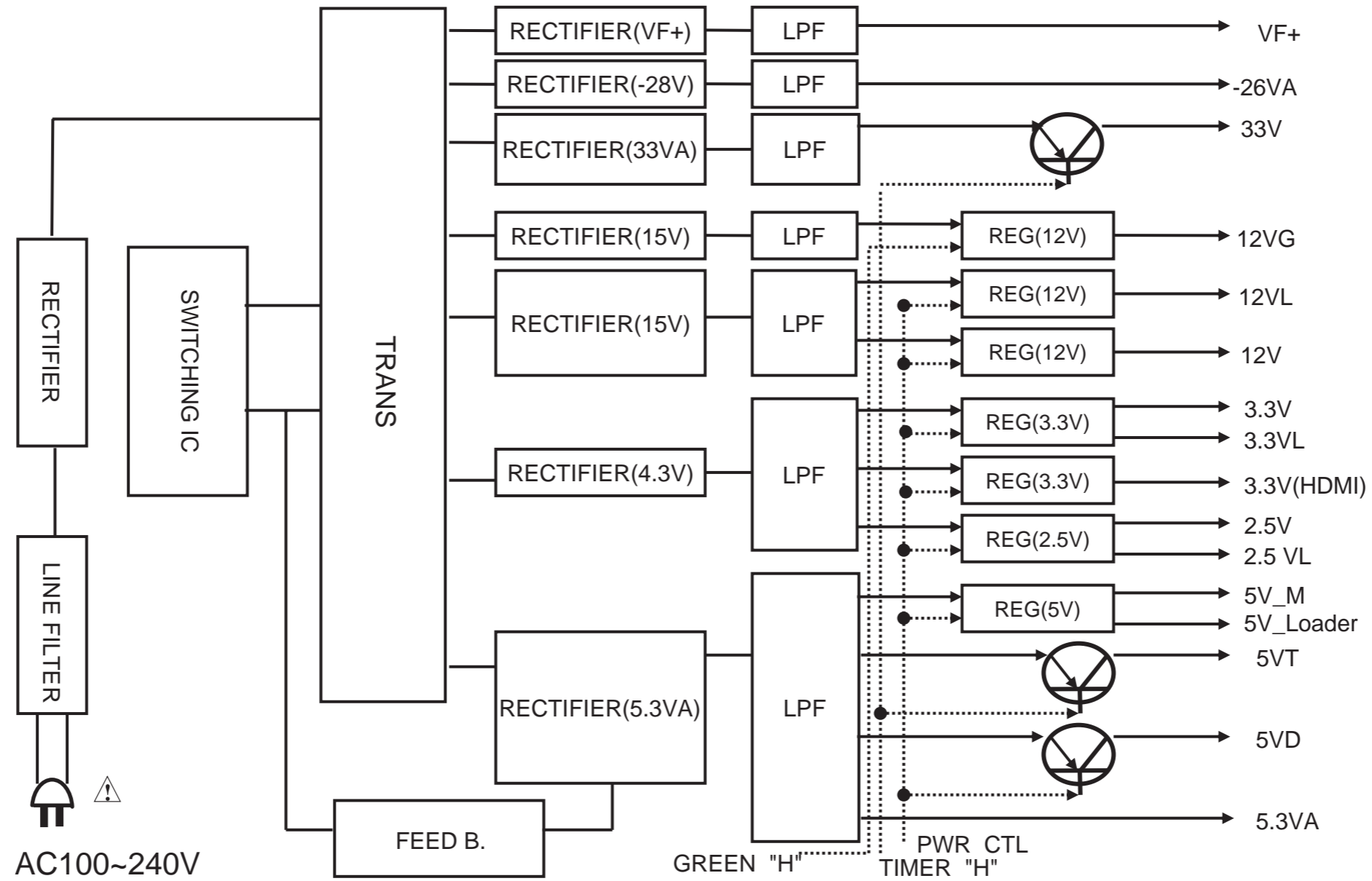

NOTES) ⚠ Warning
 Parts that are shaded are critical
 With respect to risk of fire or
 electrical shock.

2. VIDEO BLOCK DIAGRAM_PAL

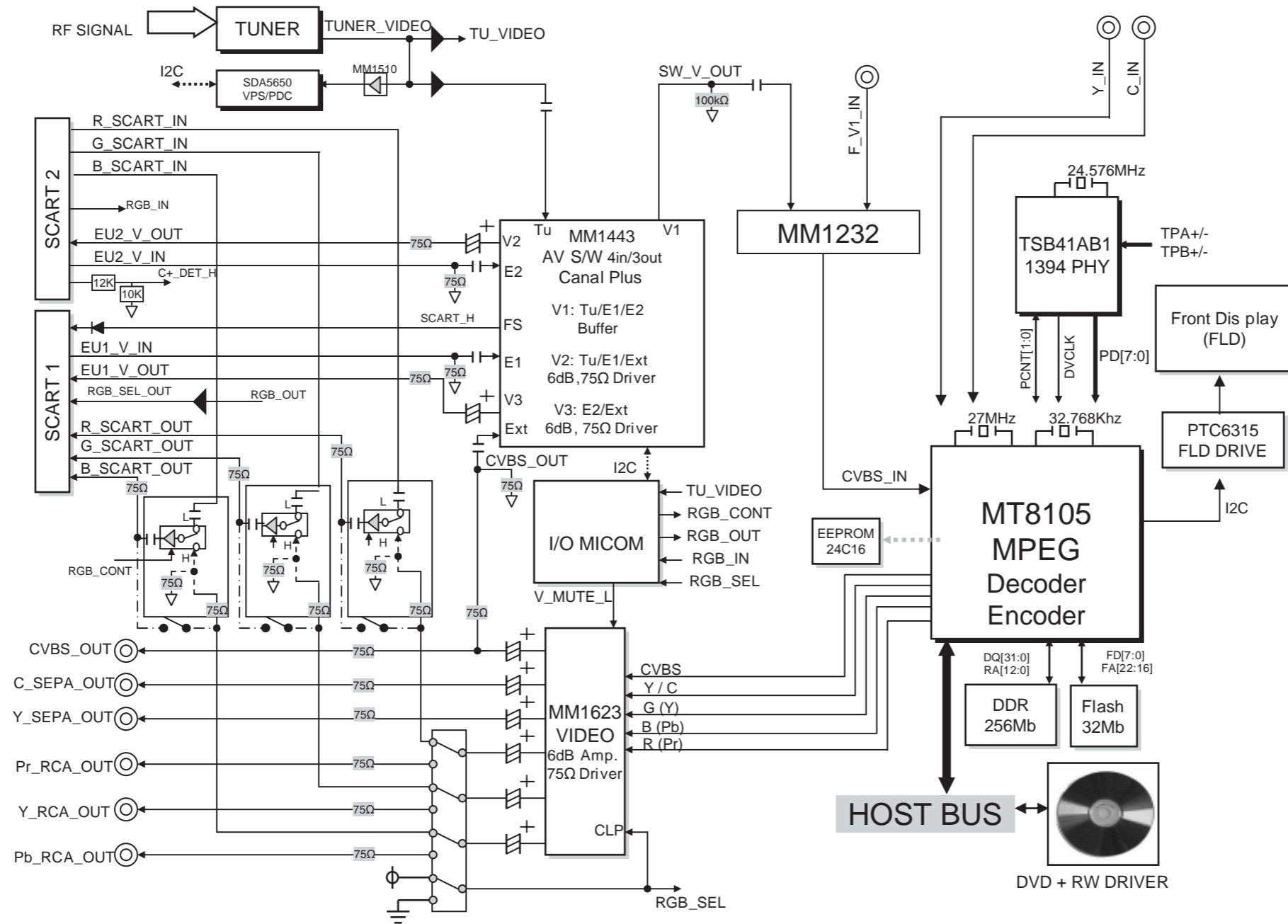

3. AUDIO BLOCK DIAGRAM PAL

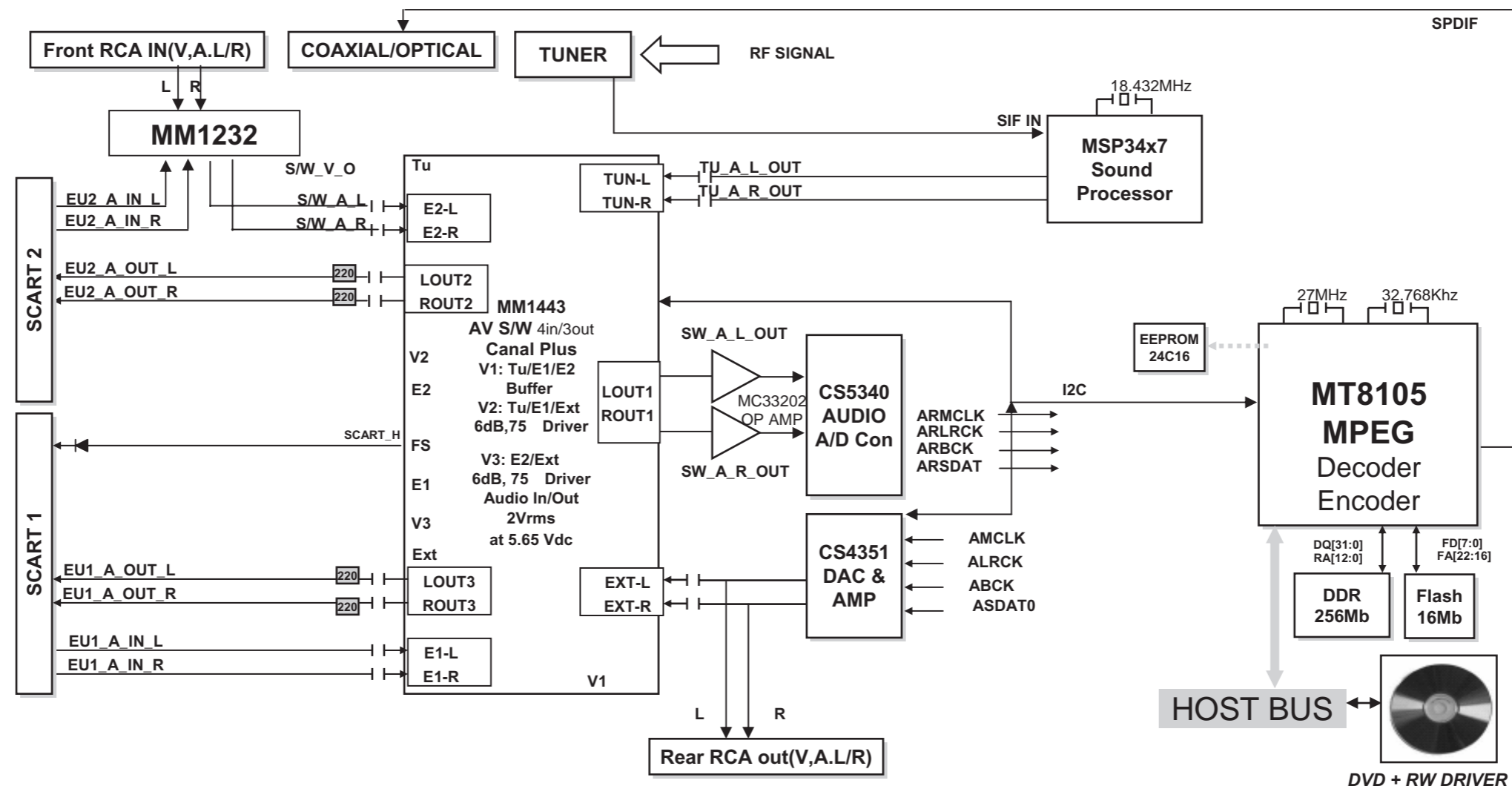

CIRCUIT DIAGRAMS

1. POWER CIRCUIT DIAGRAM

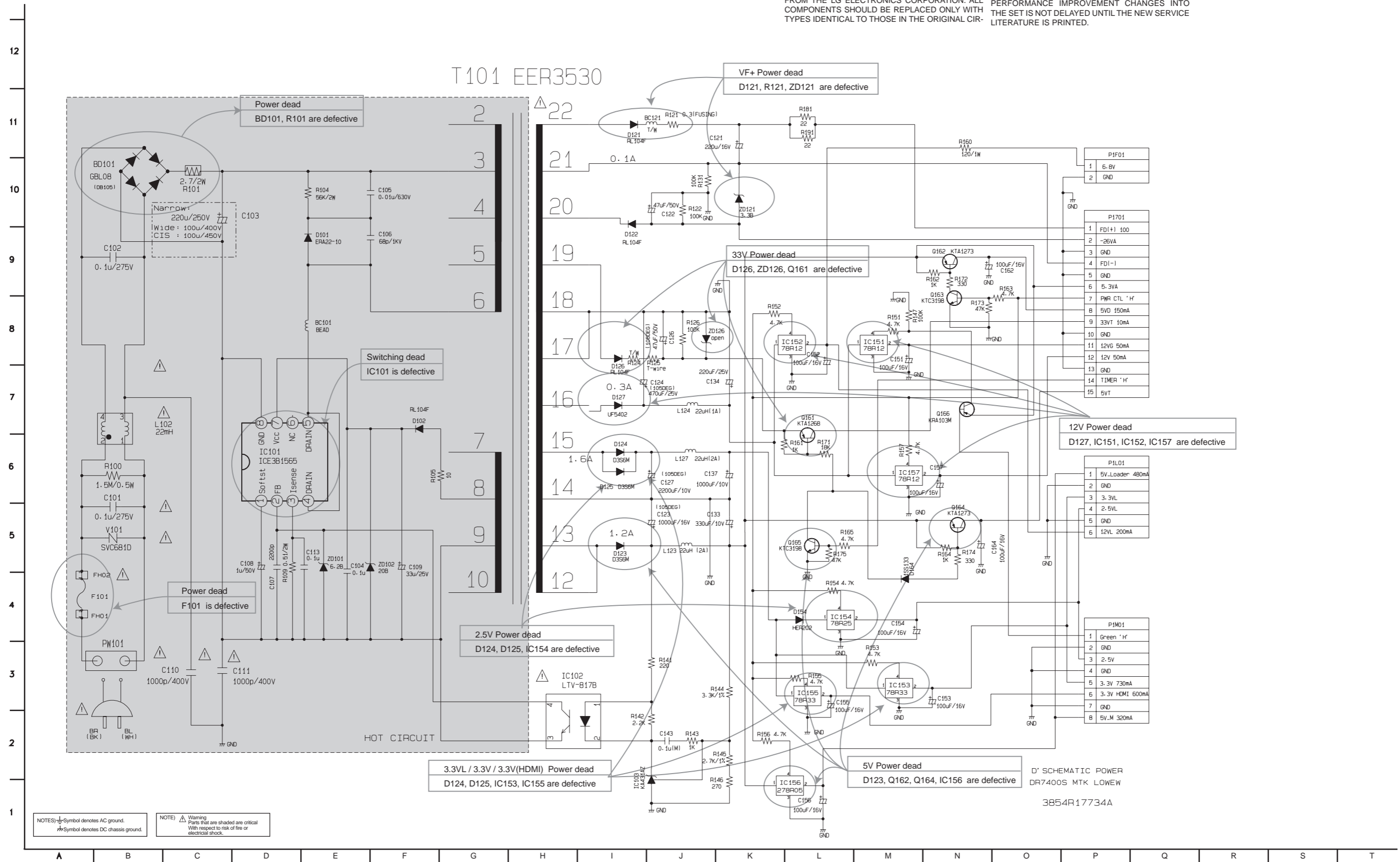

2. I/O MICOM CIRCUIT DIAGRAM

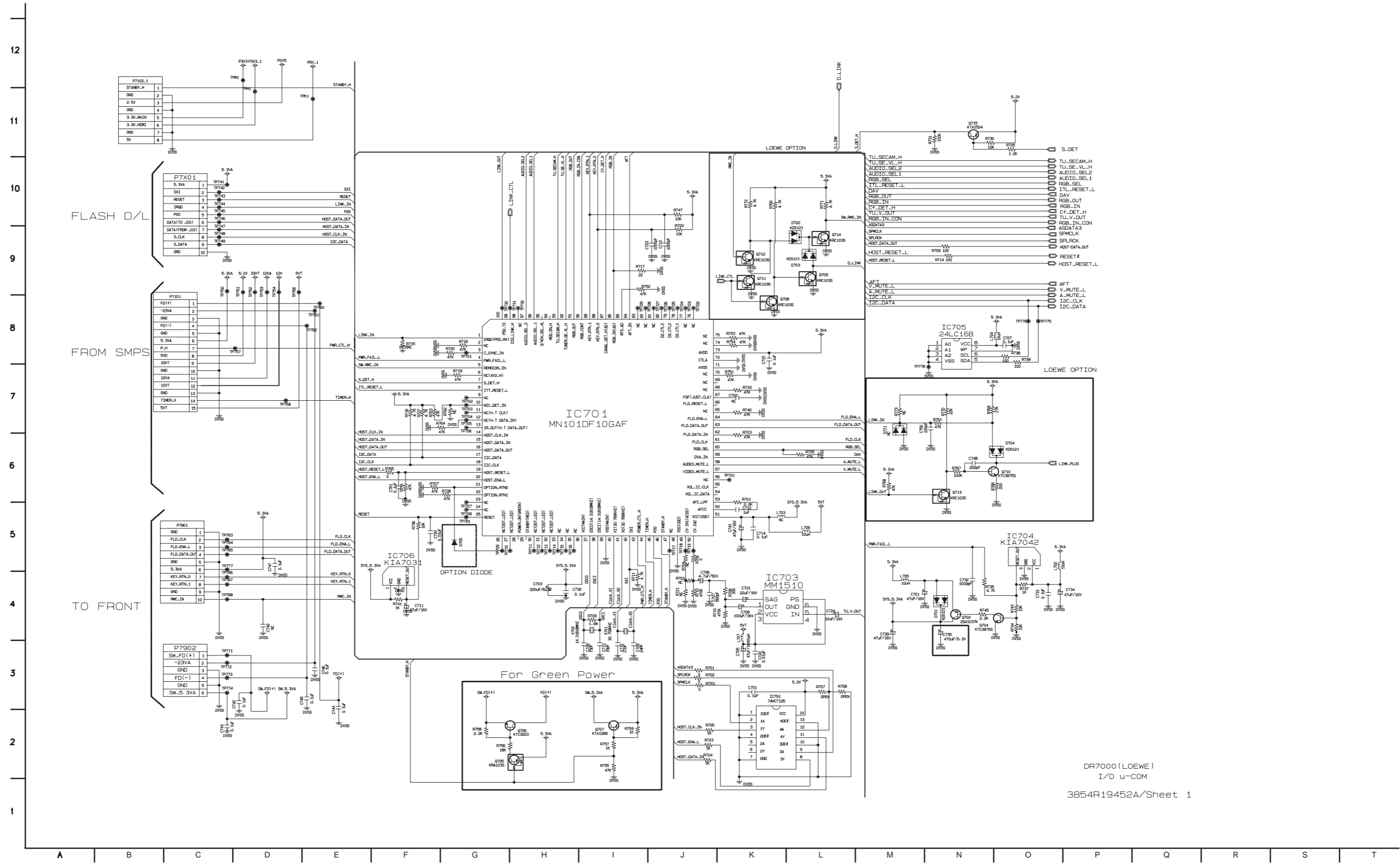

DR7000 (LOEWE)
I/O u-COM
3854R19452A/Sheet 1

3. TUNER/MPX/ADC/DAC/JACK CIRCUIT DIAGRAM

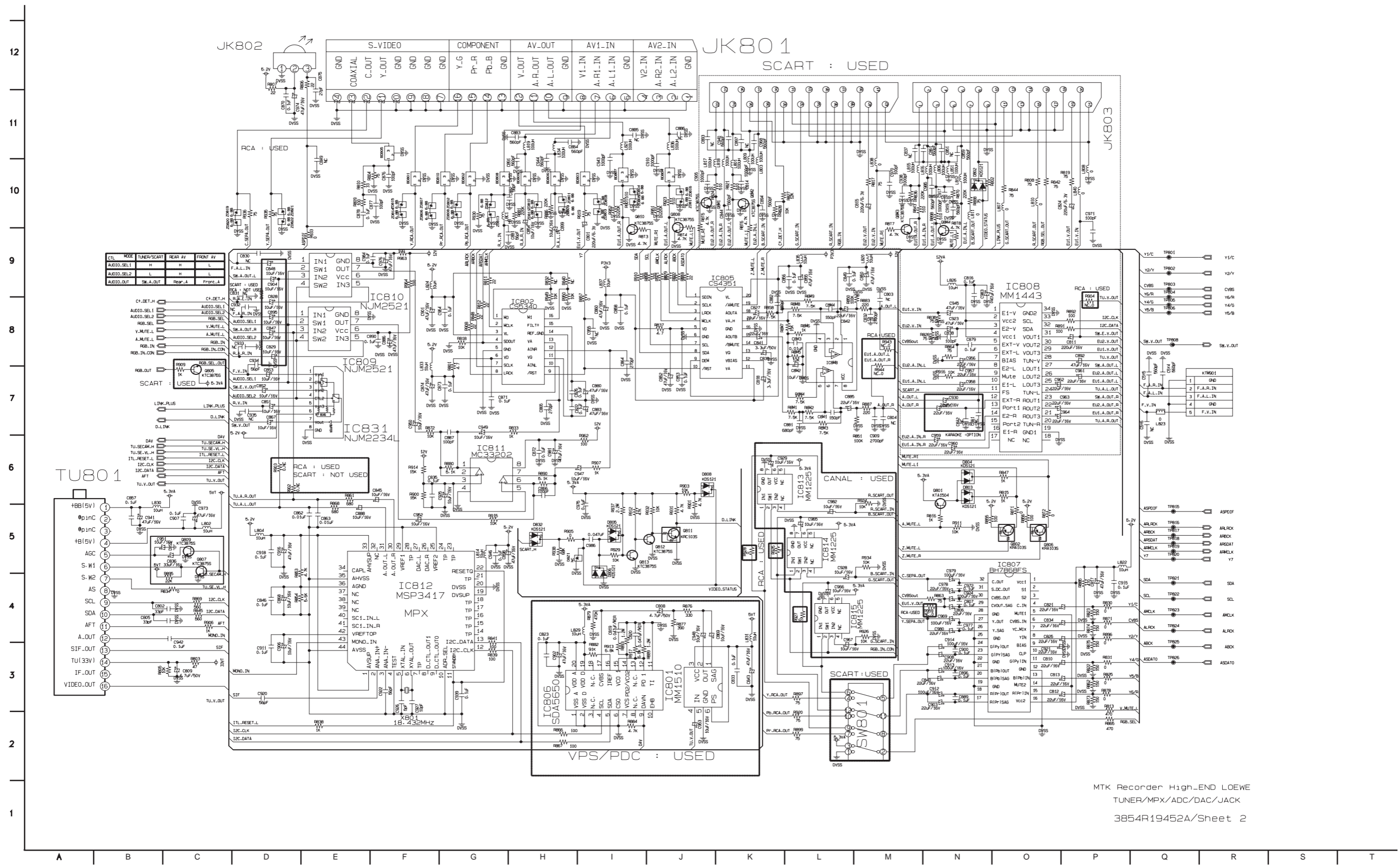

MTK Recorder High-END LOEWE
TUNER/MPX/ADC/DAC/JACK
3854R19452A/Sheet 2

4. MPEG CIRCUIT DIAGRAM

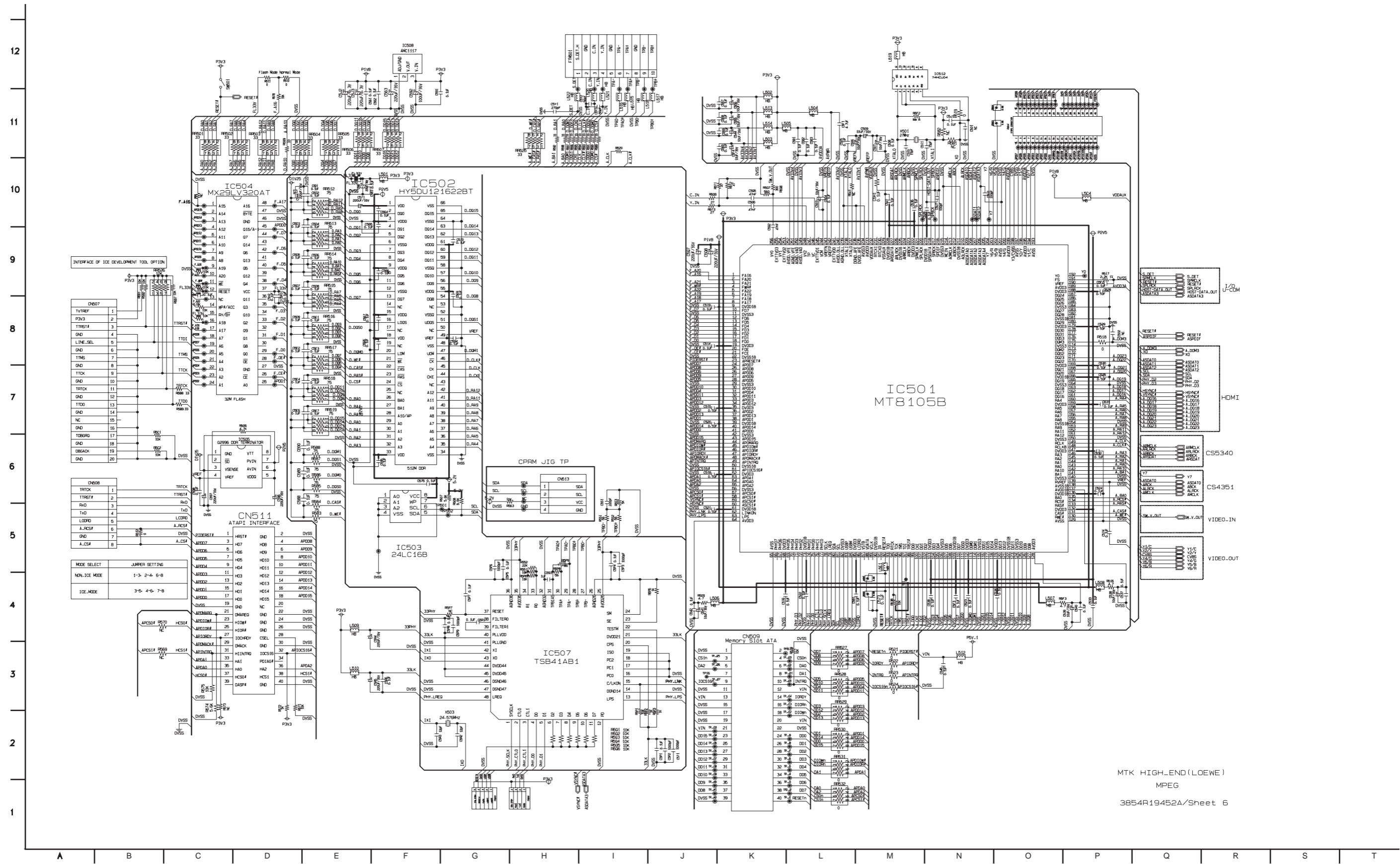

4. TIMER/KEY CIRCUIT DIAGRAM

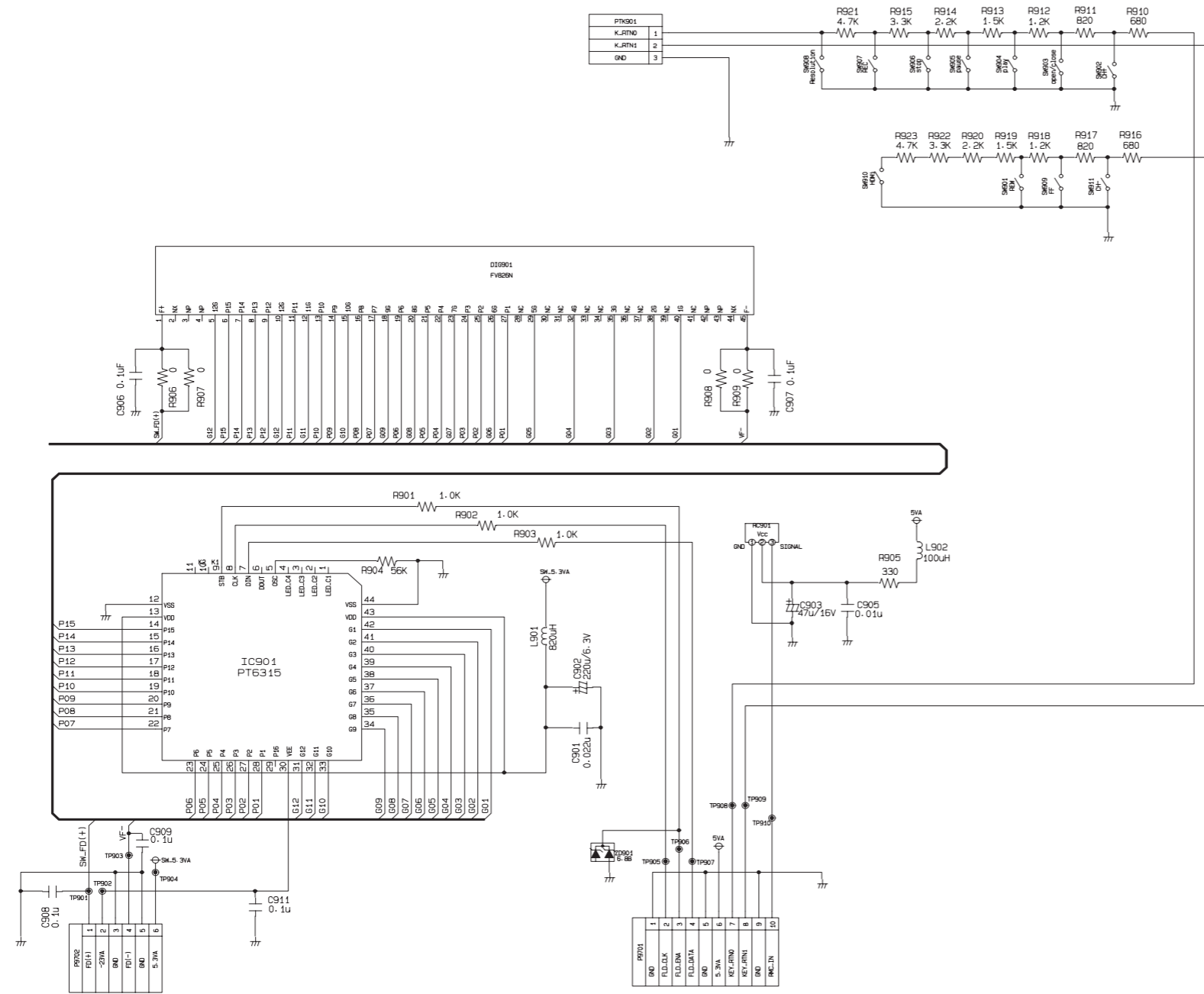

MTK RECORDER LOEWE
 TIMER/KEY BOARD_Sheet 1
 3854R19454A

6. FRONT AV JACK CIRCUIT DIAGRAM

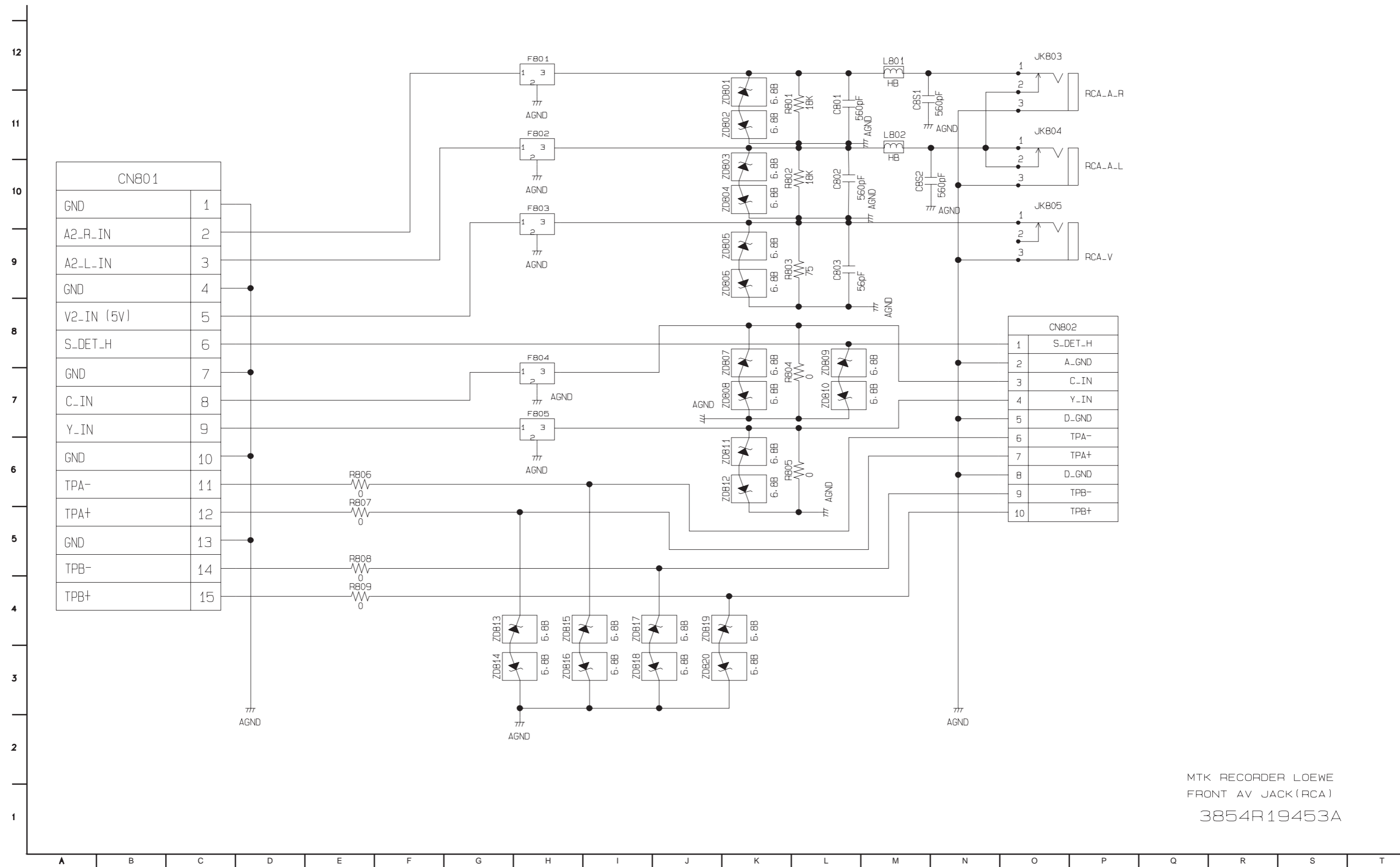

MTK RECORDER LOEWE
 FRONT AV JACK(RCA)
 3854R19453A

7. FRONT AV JACK_DV+SUPER CIRCUIT DIAGRAM

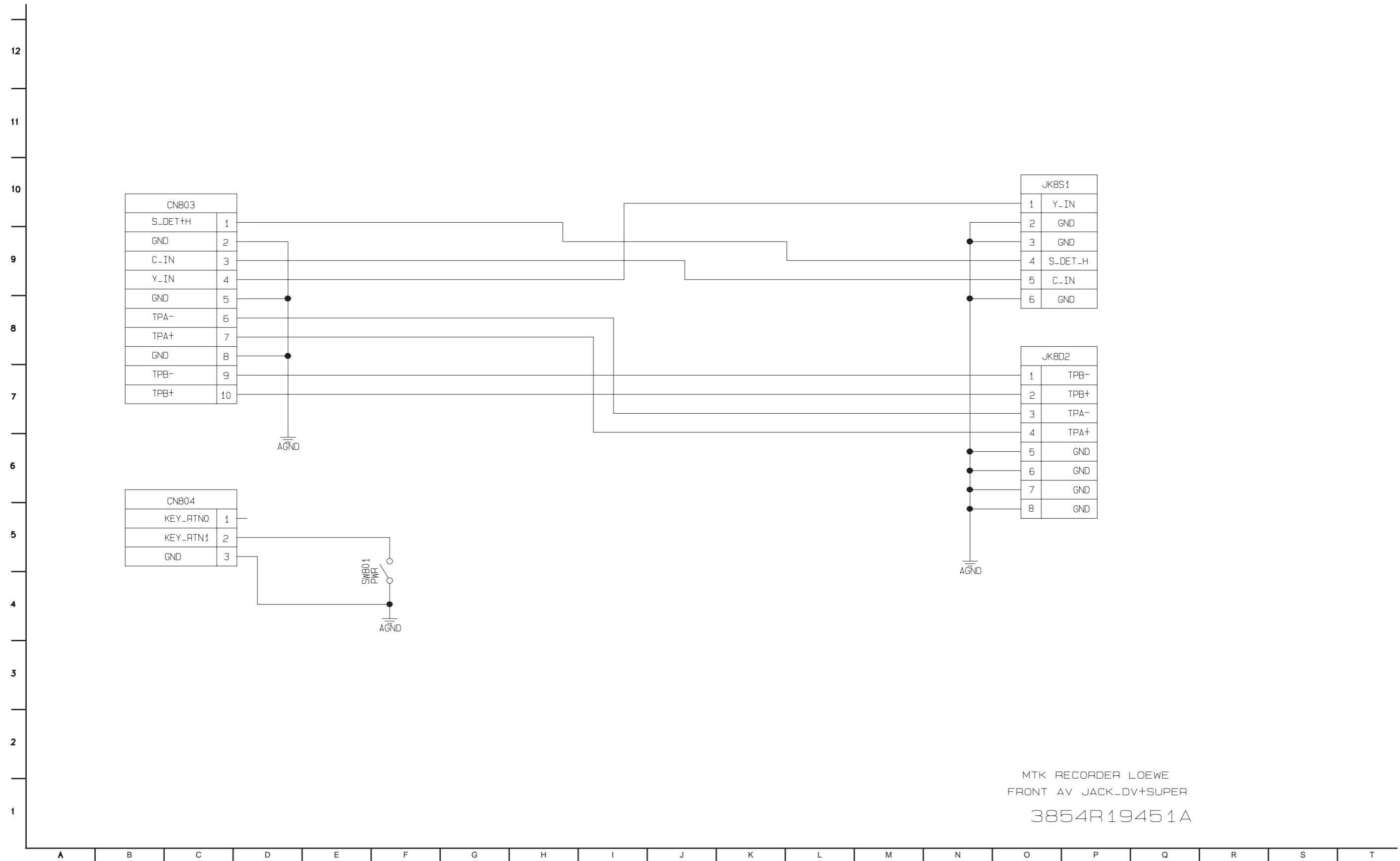

MTK RECORDER LOEWE
FRONT AV JACK_DV+SUPER

3854R19451A

PRINTED CIRCUIT DIAGRAMS

1. MAIN P.C.BOARD (TOP SIDE)

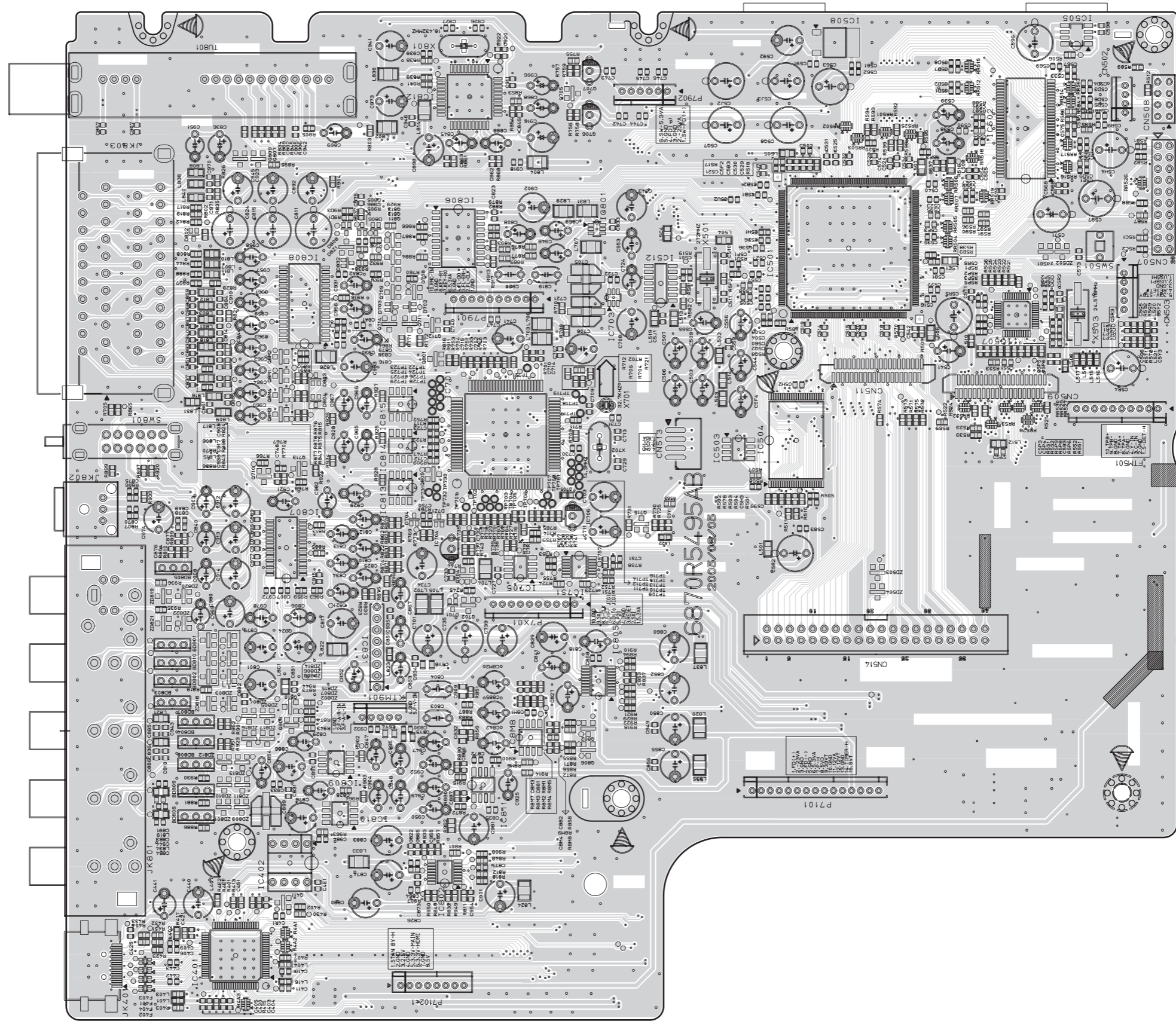

2. MAIN P.C.BOARD (BOTTOM SIDE)

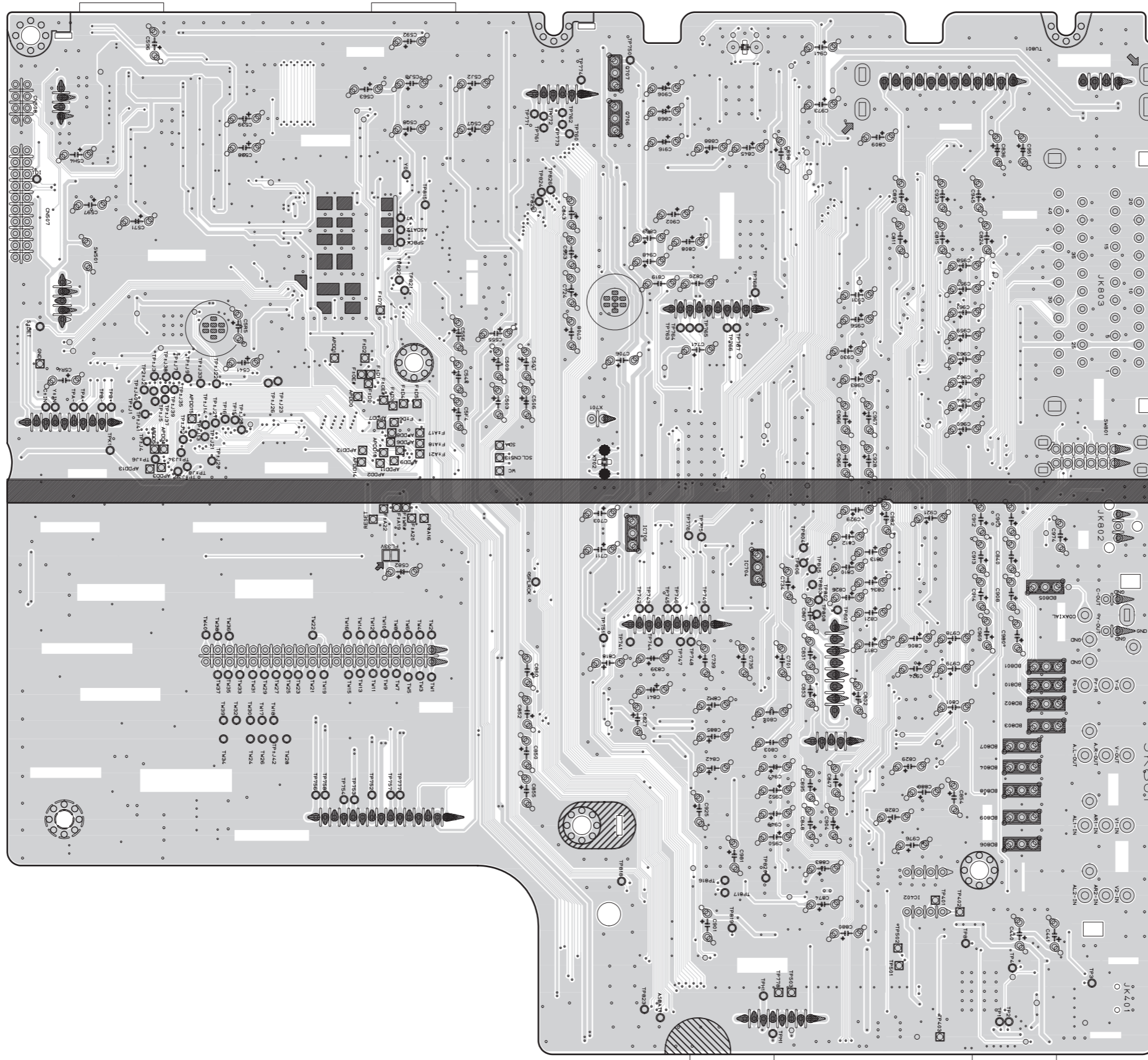

**3. JACK P.C.BOARD
(TOP SIDE)**

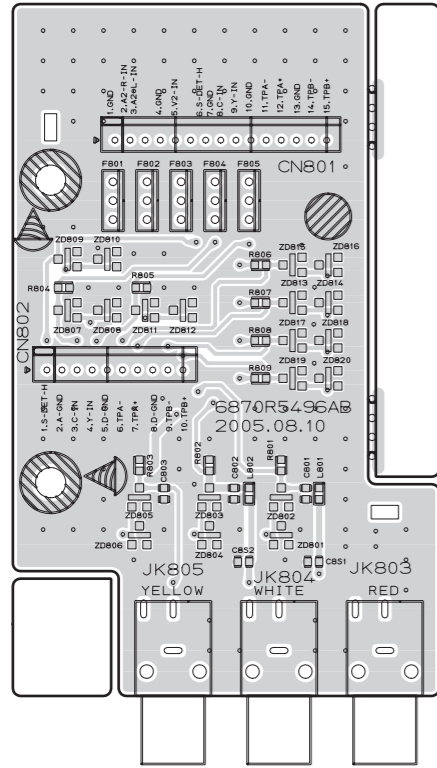

(BOTTOM SIDE)

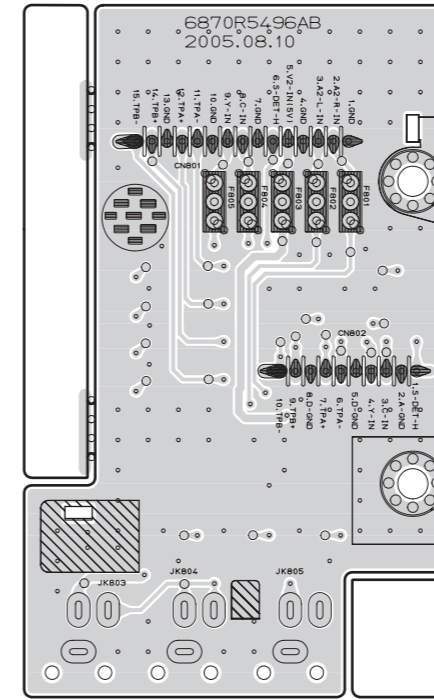

**4. FRONT P.C.BOARD
(TOP SIDE)**

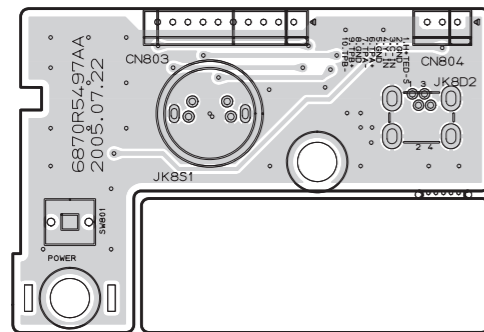

(BOTTOM SIDE)

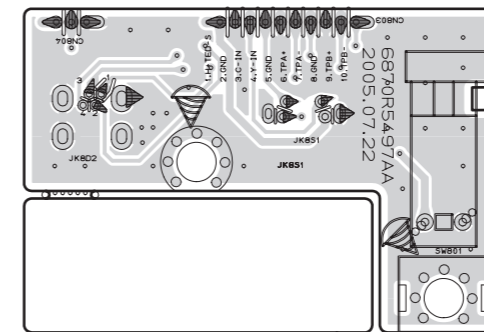

5. KEY TIMER P.C.BOARD (TOP SIDE)

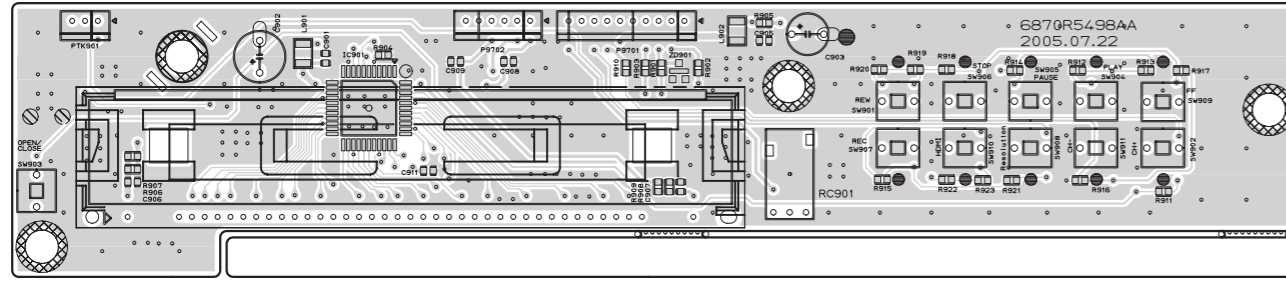

(TOP SIDE)

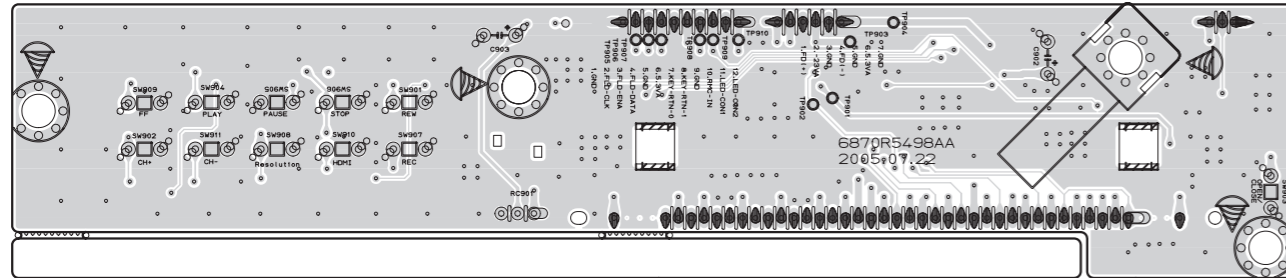

6. POWER P.C.BOARD

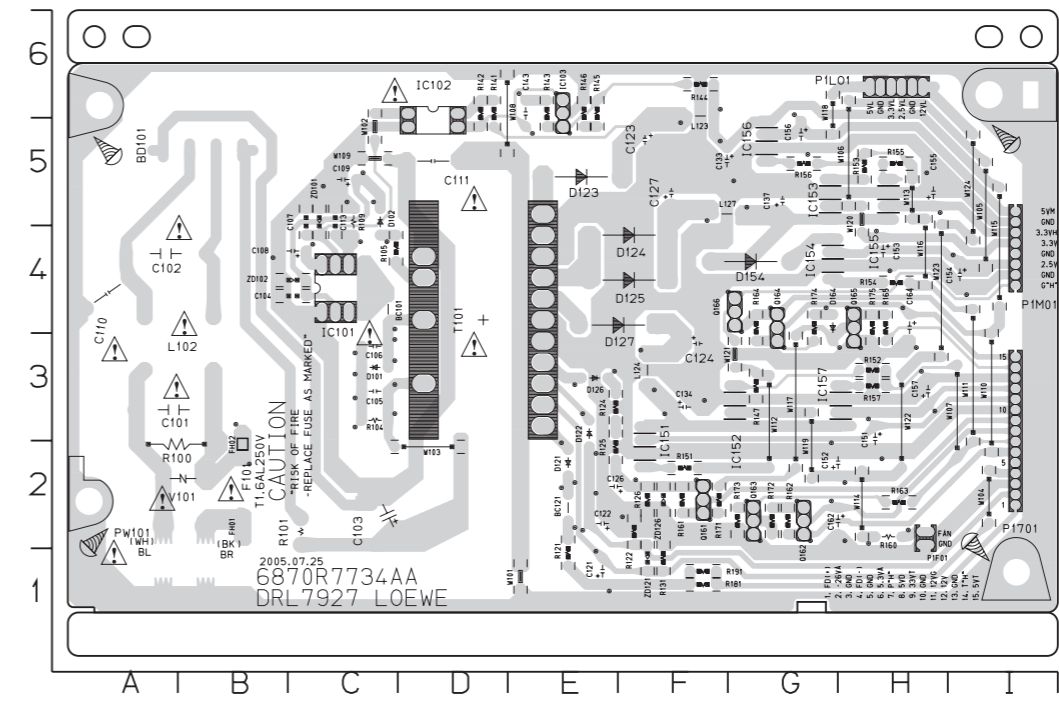

NOTES) ⚠ Warning
Parts that are shaded are critical
With respect to risk of fire or
electrical shock.

MTK LOADER PART ELECTRICAL TROUBLESHOOTING GUIDE

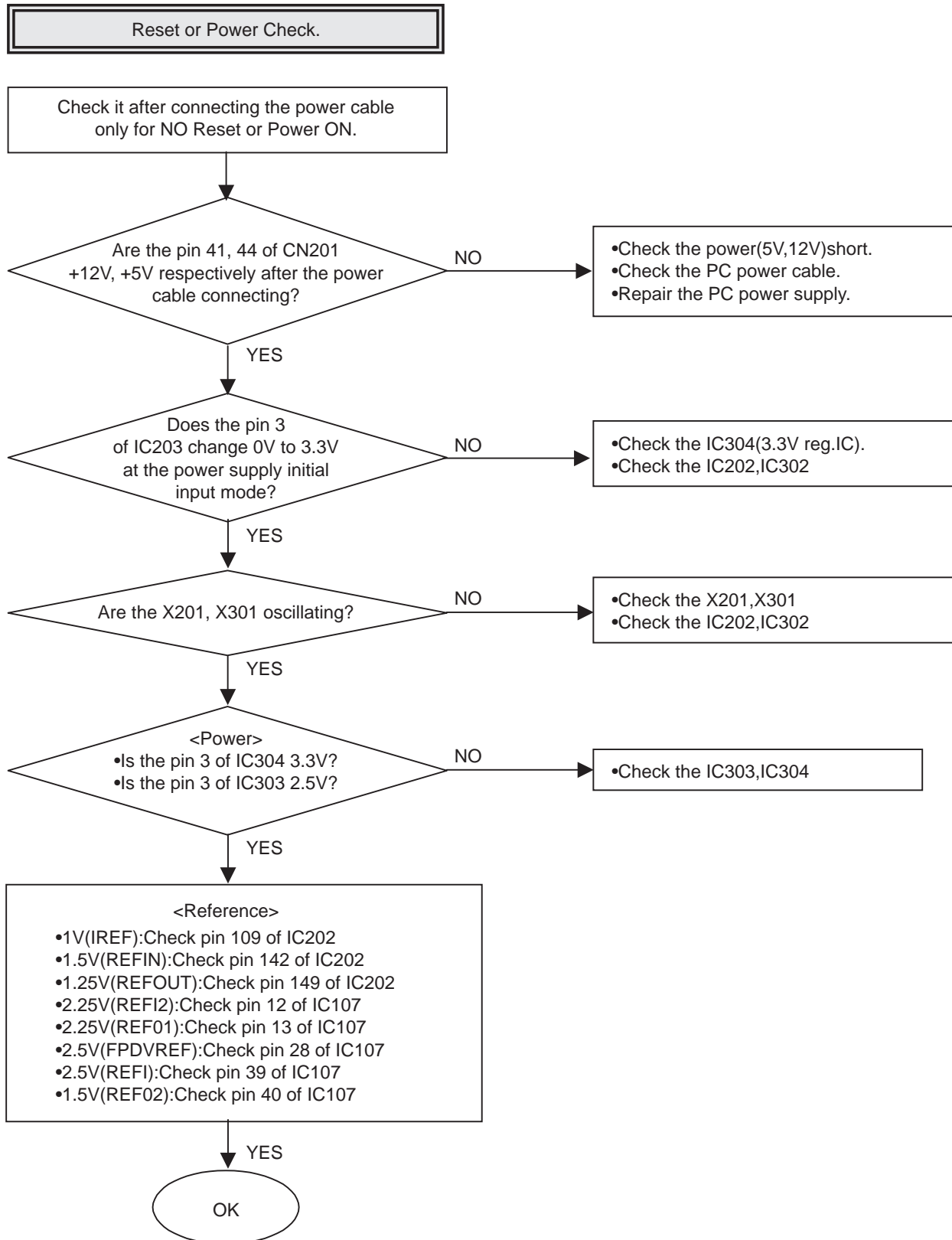

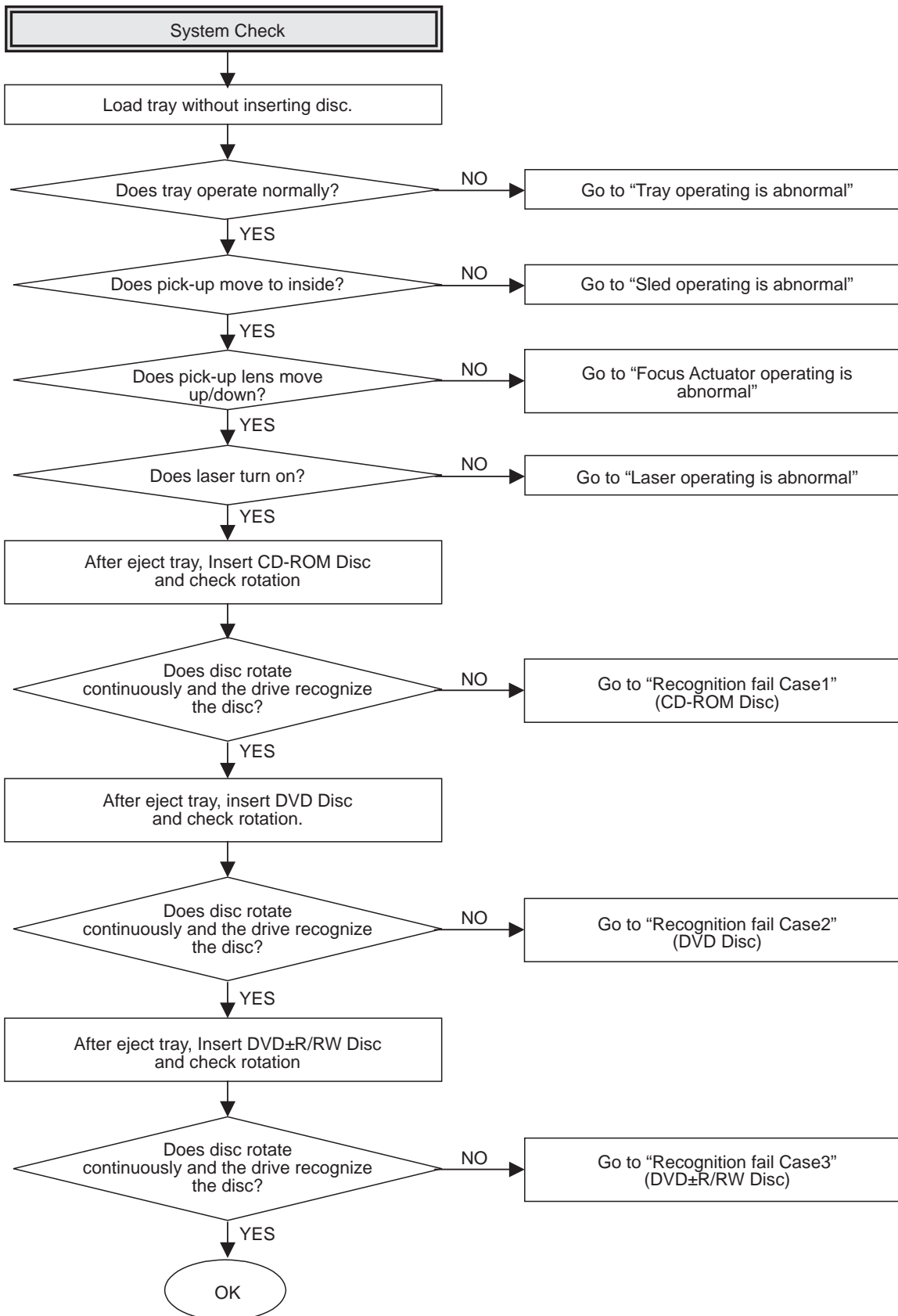

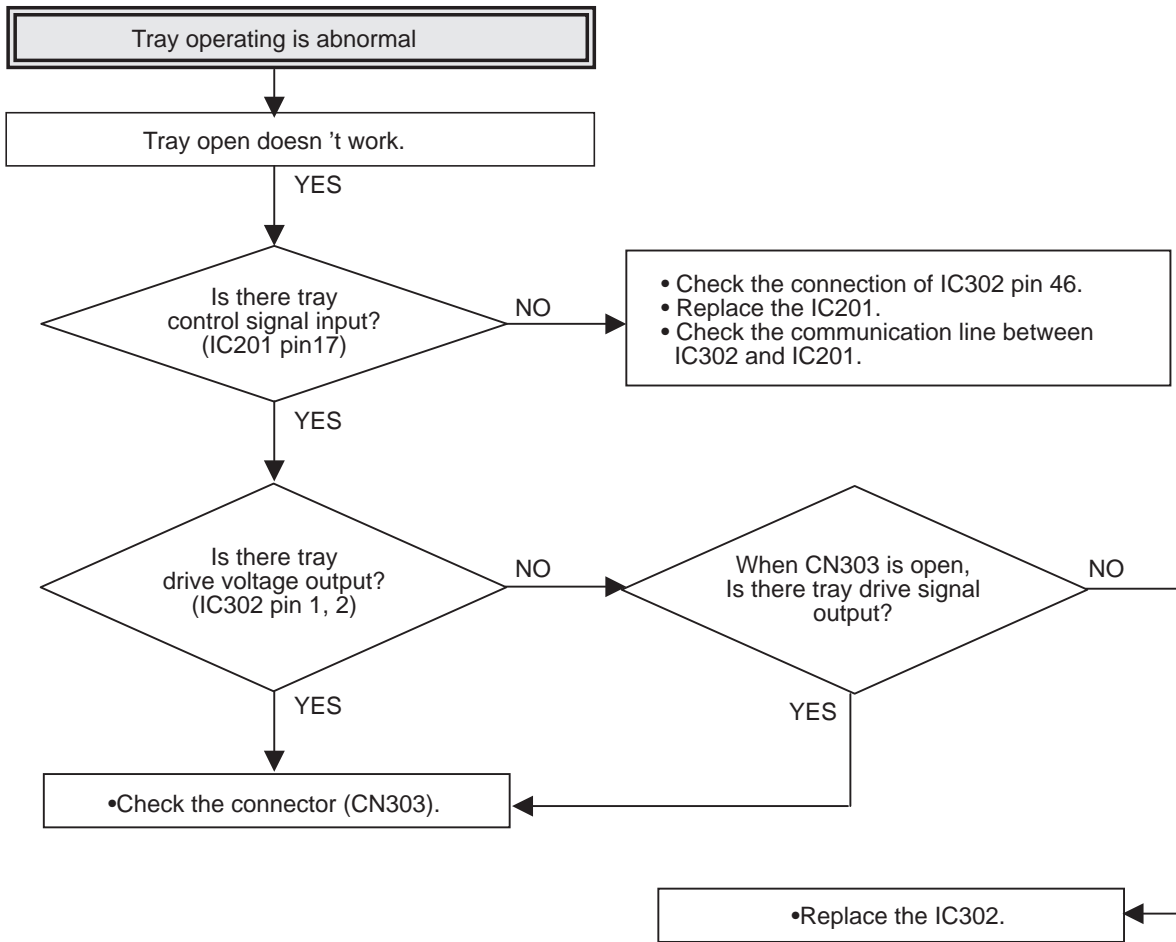

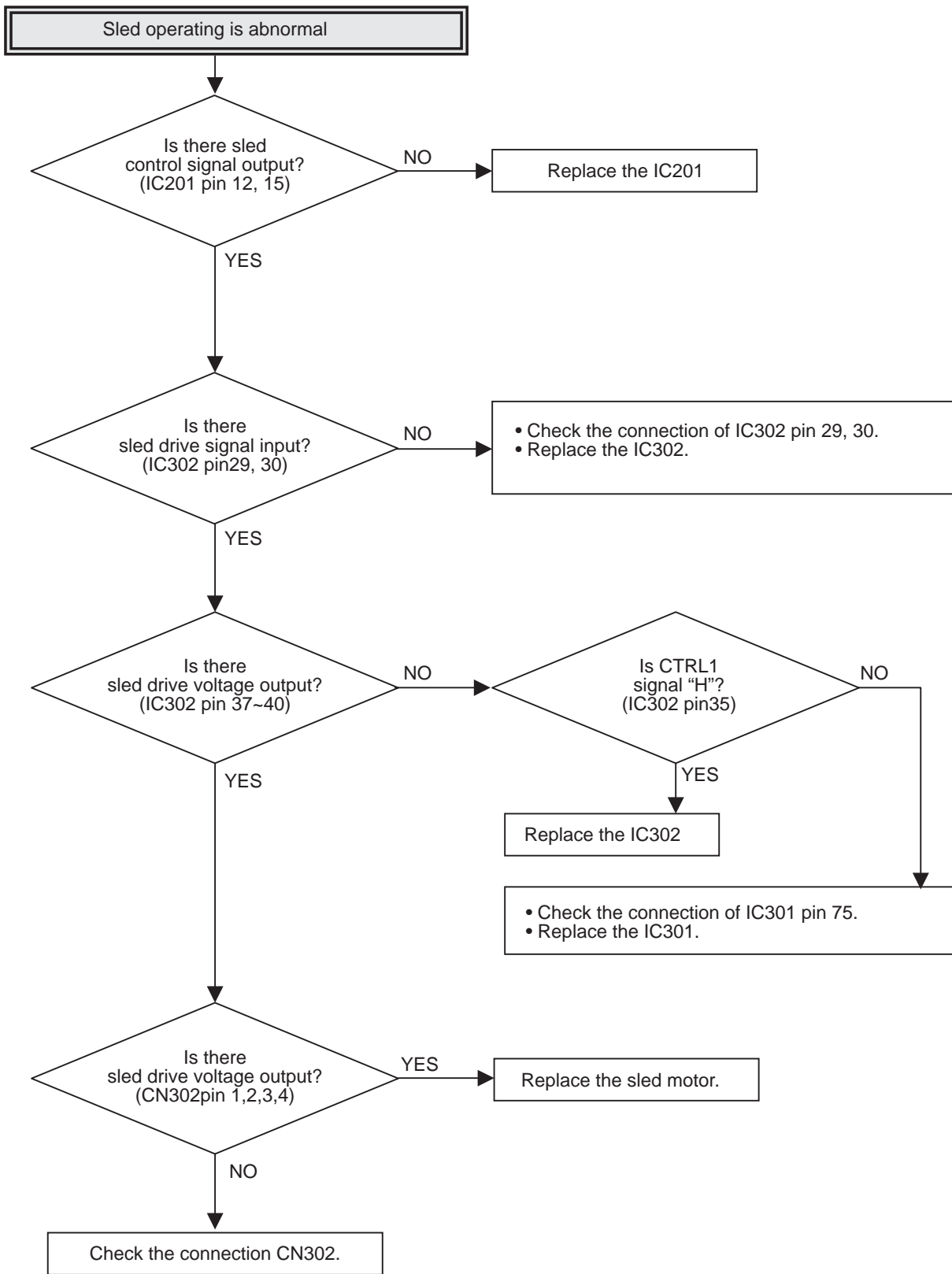

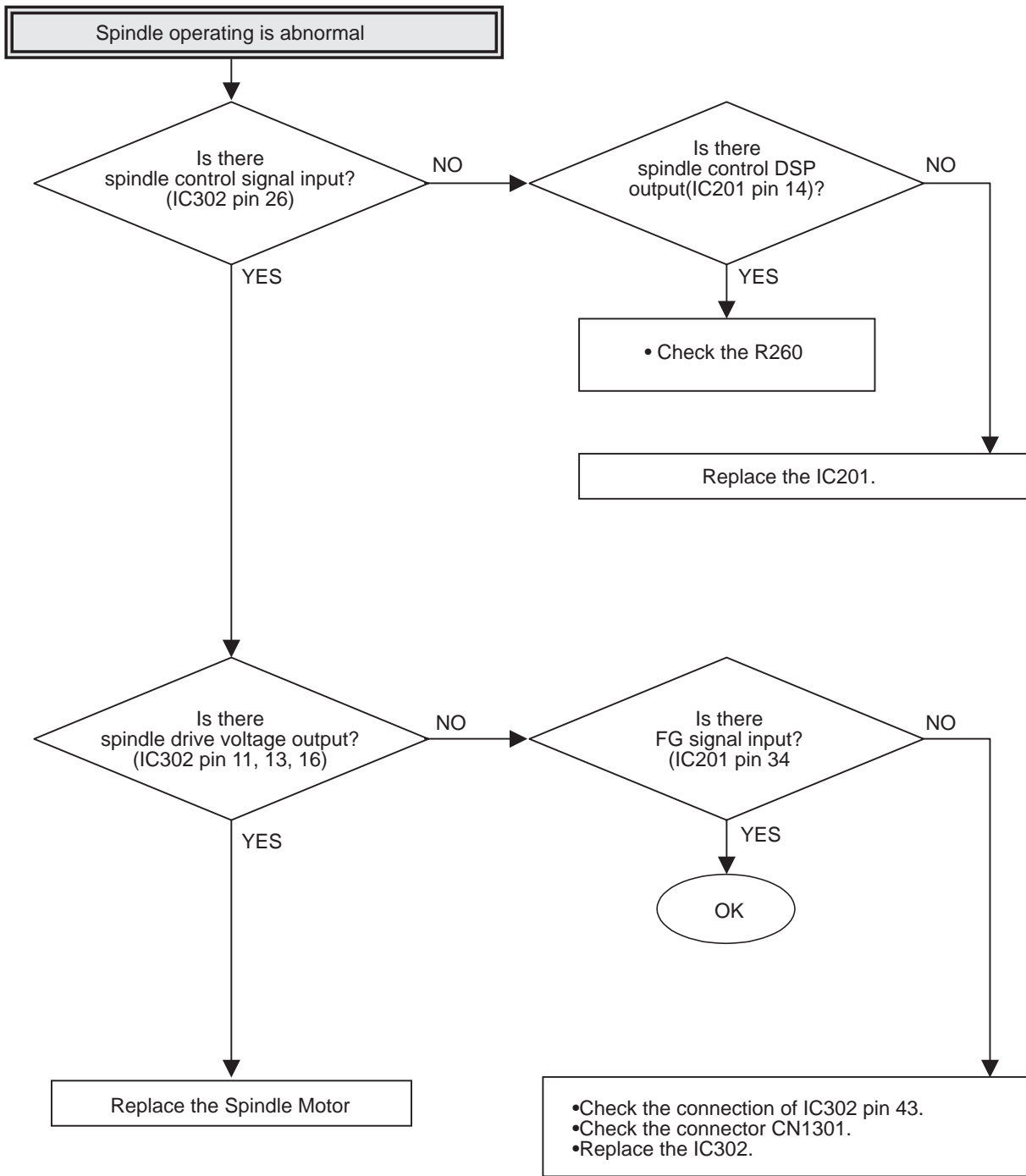

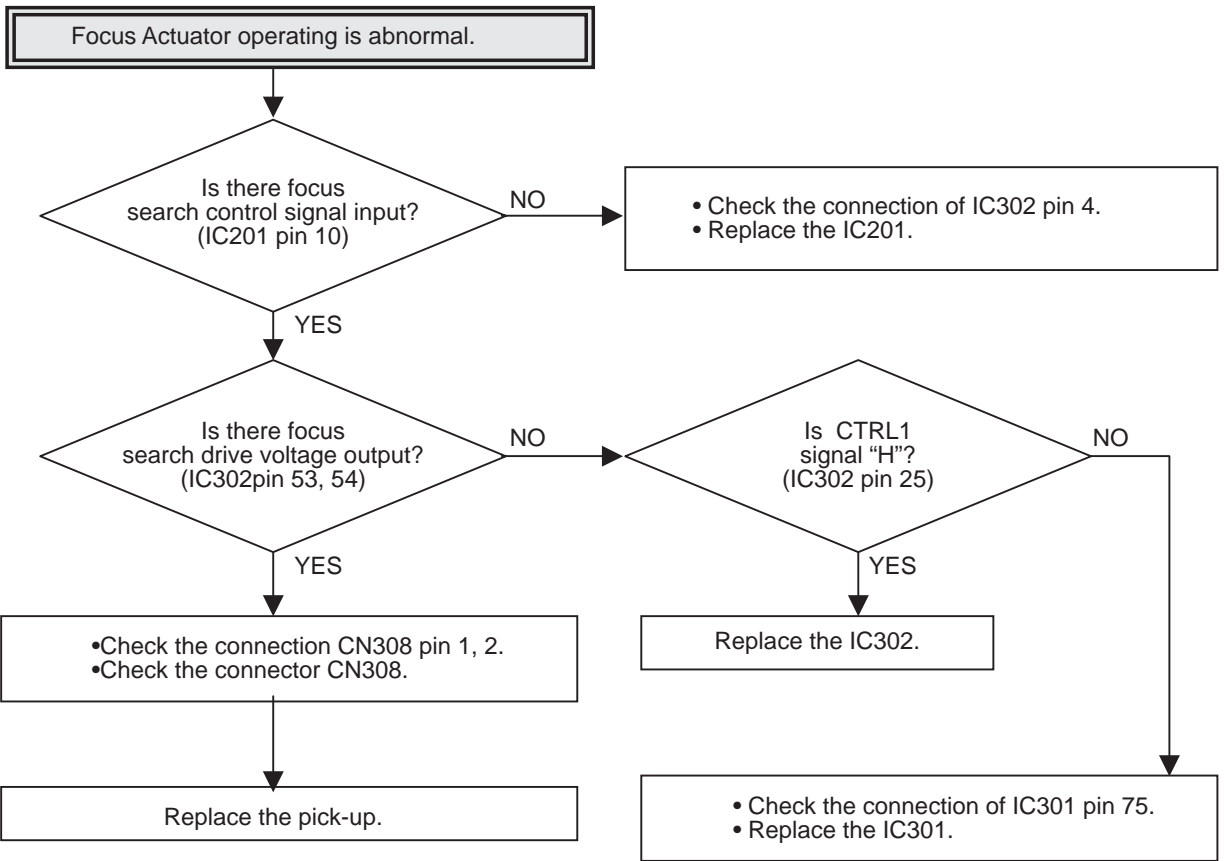
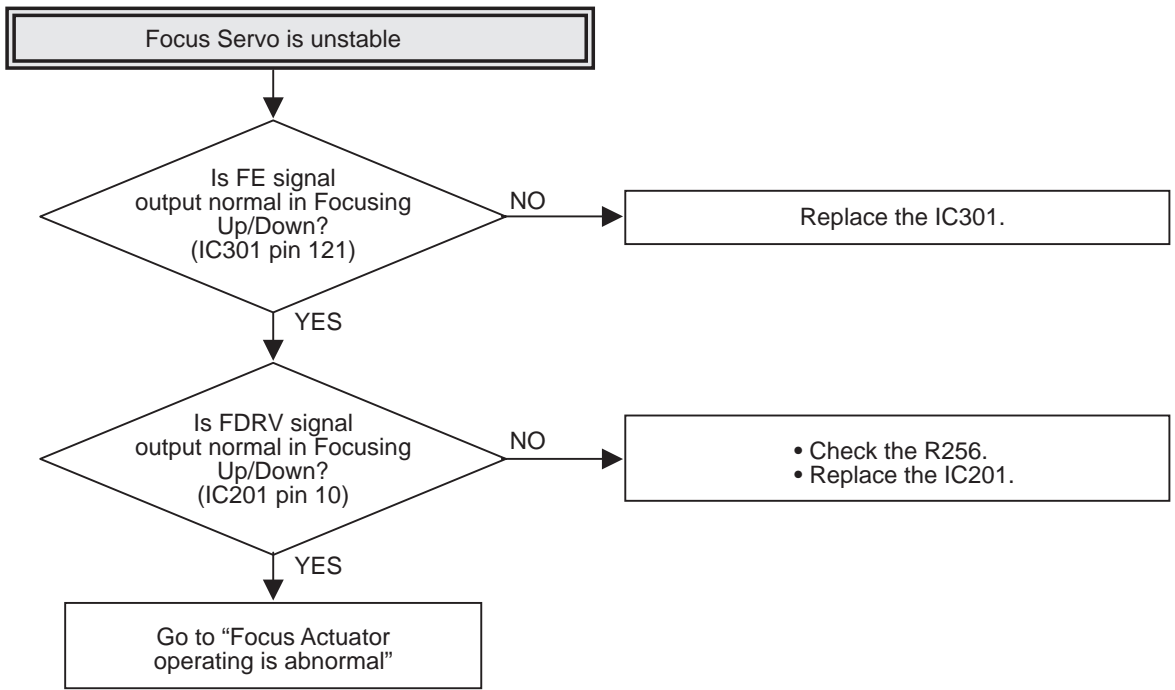

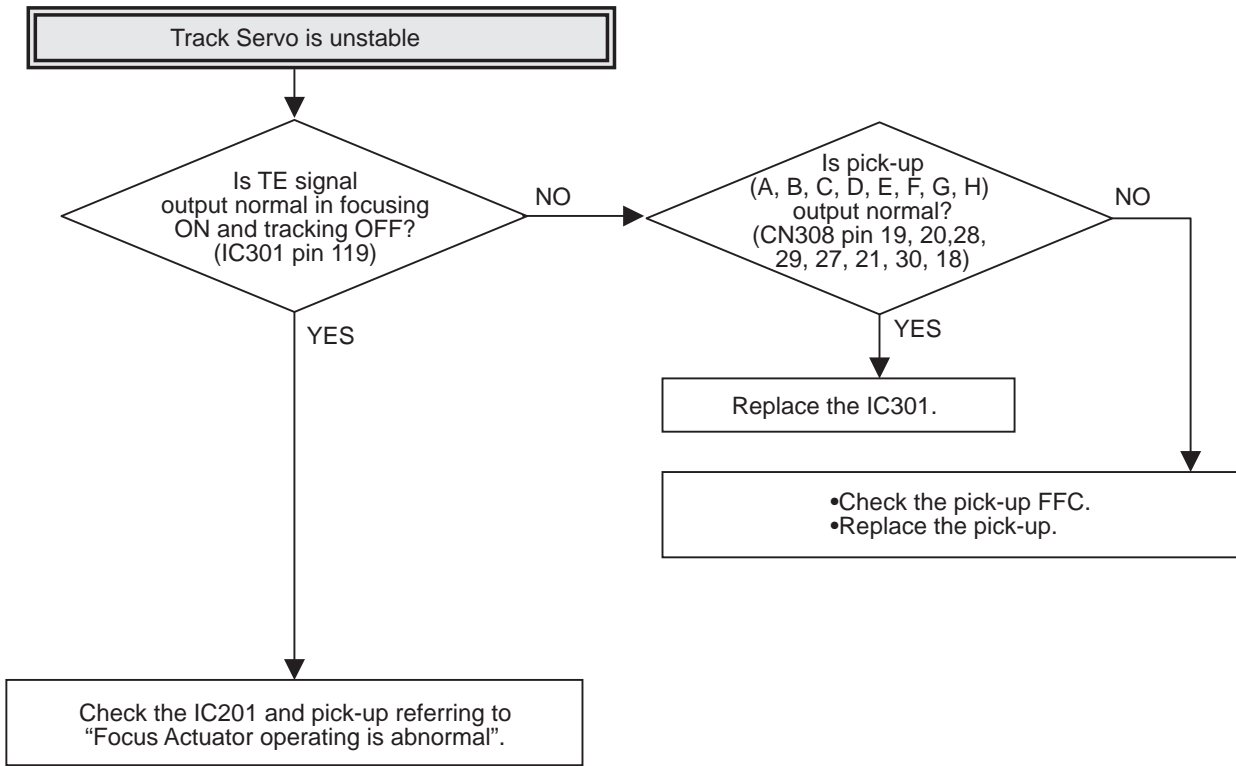

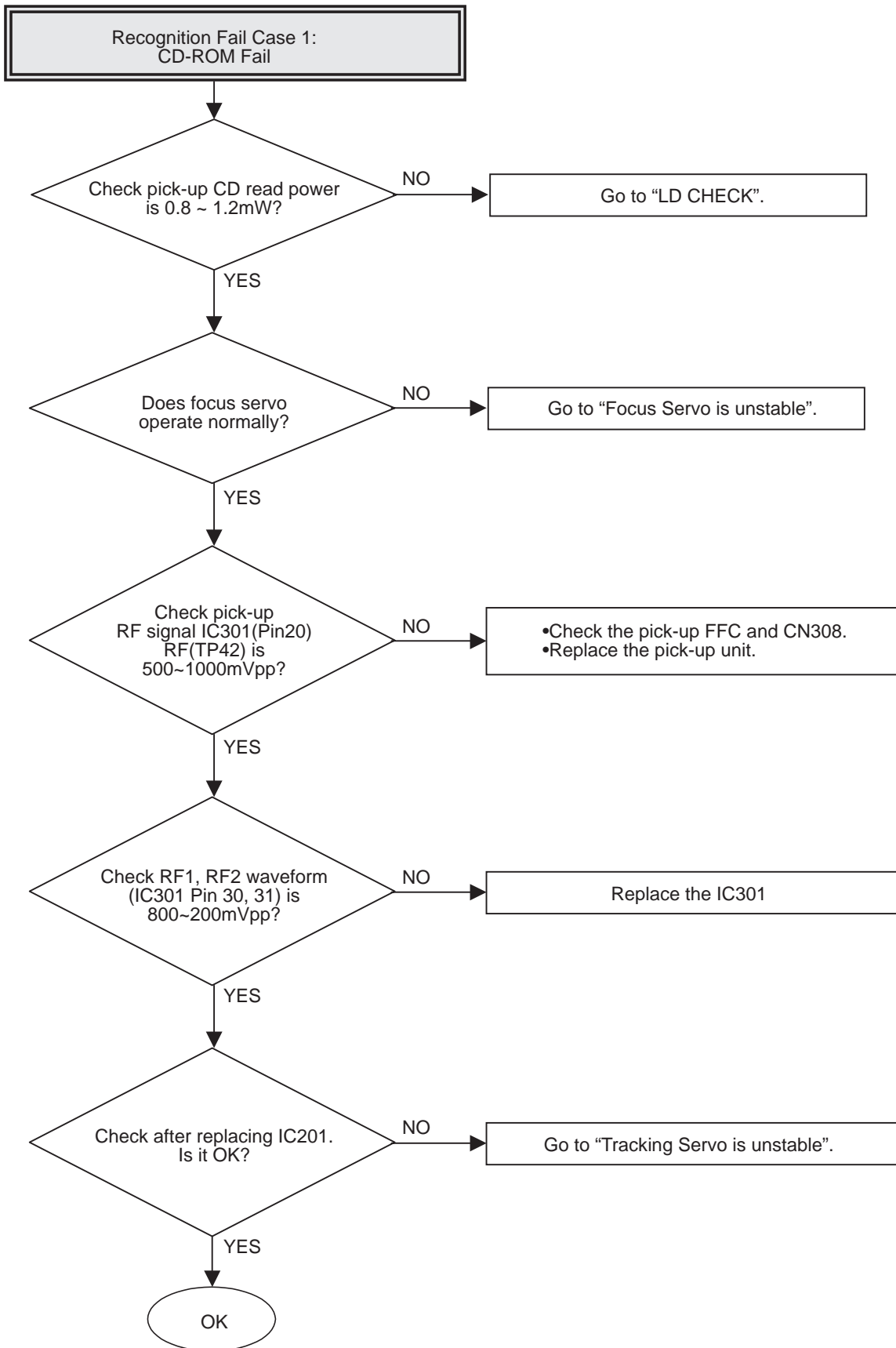

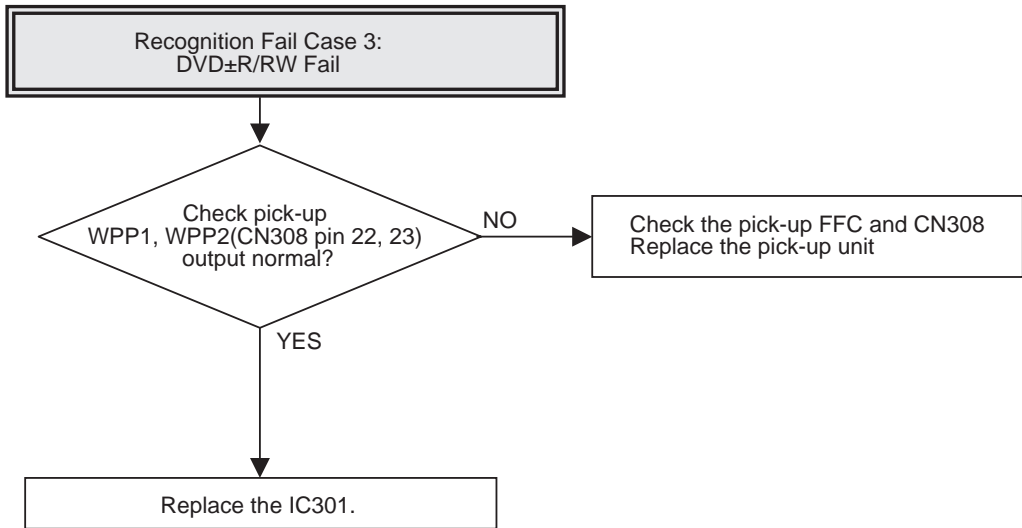
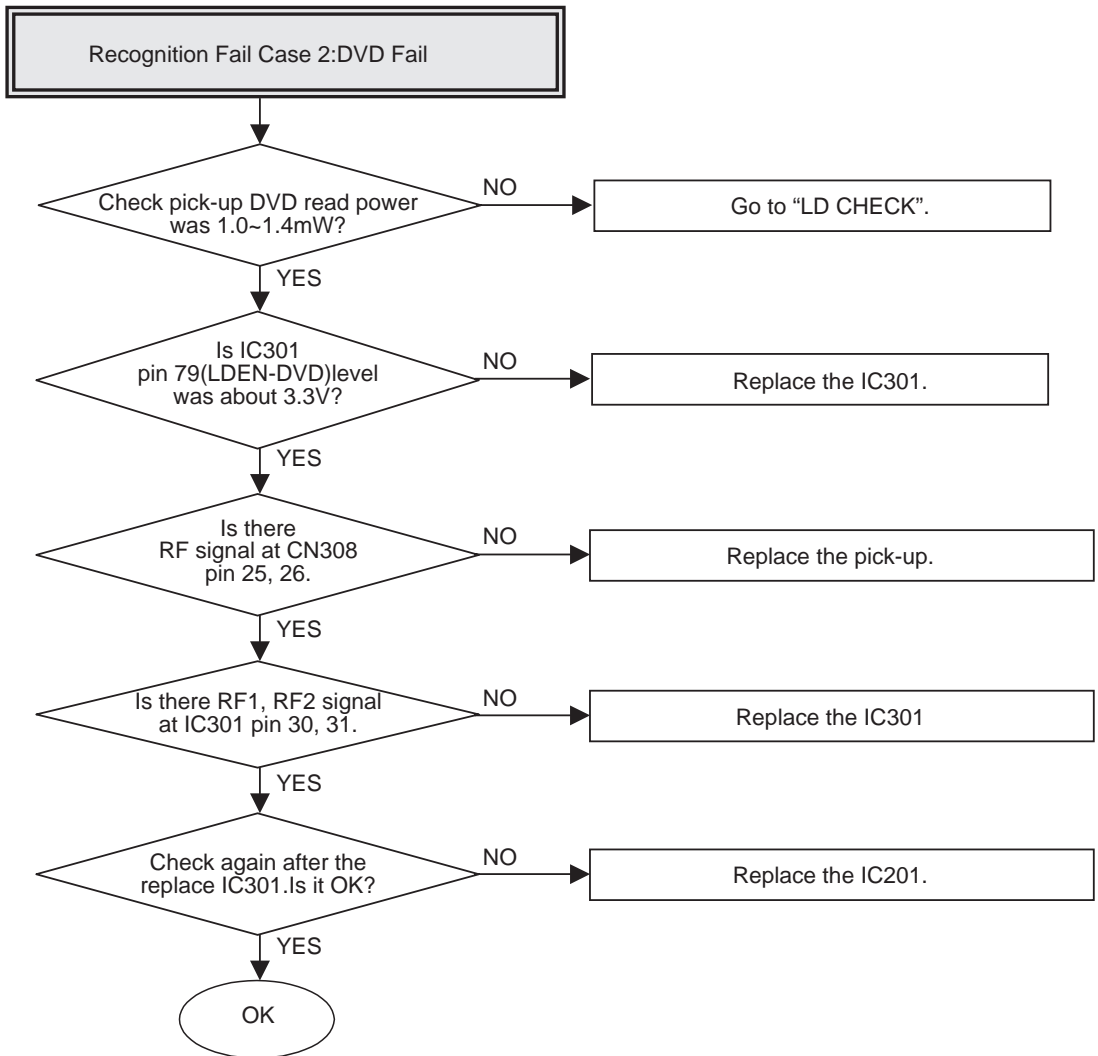

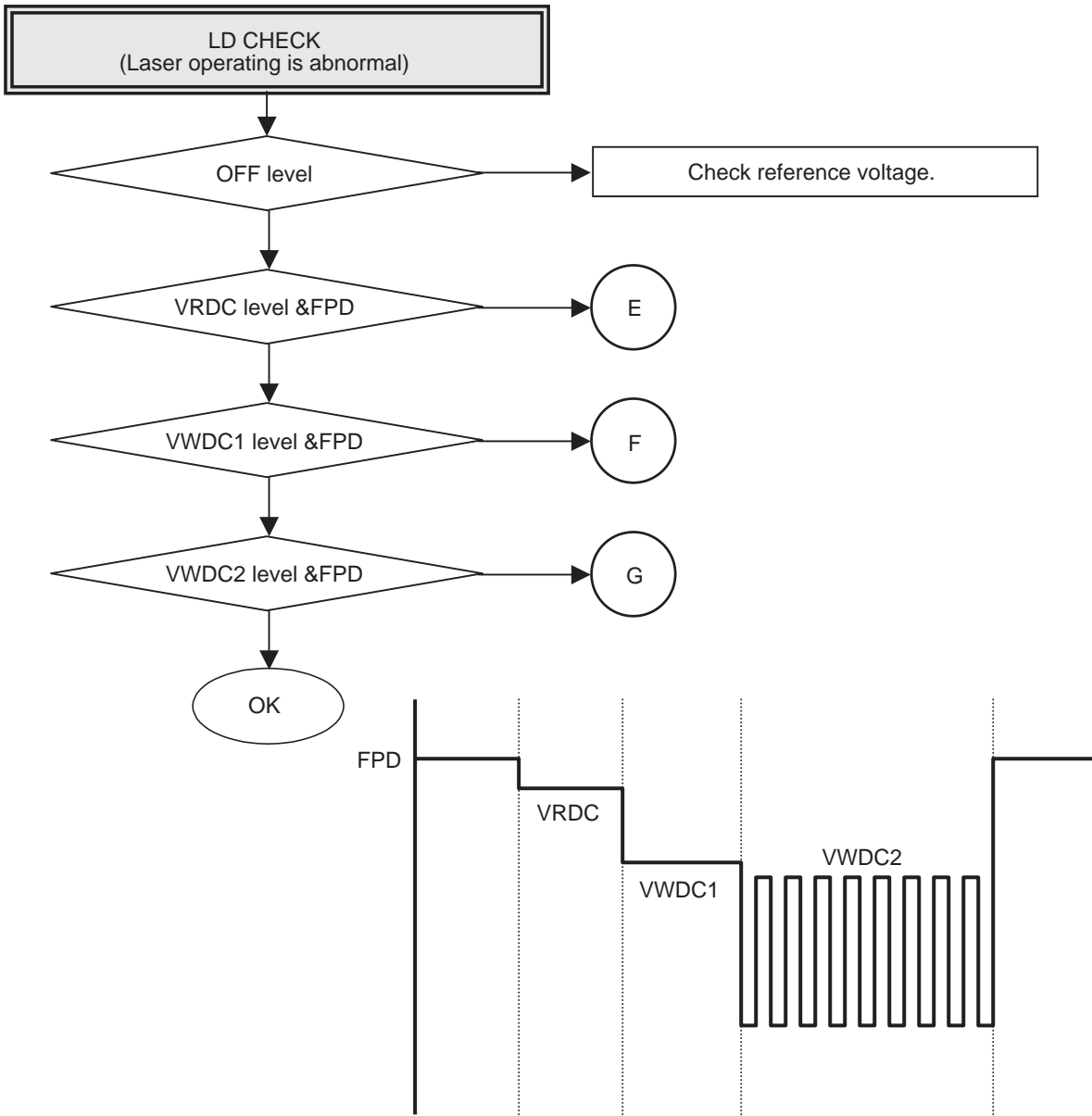

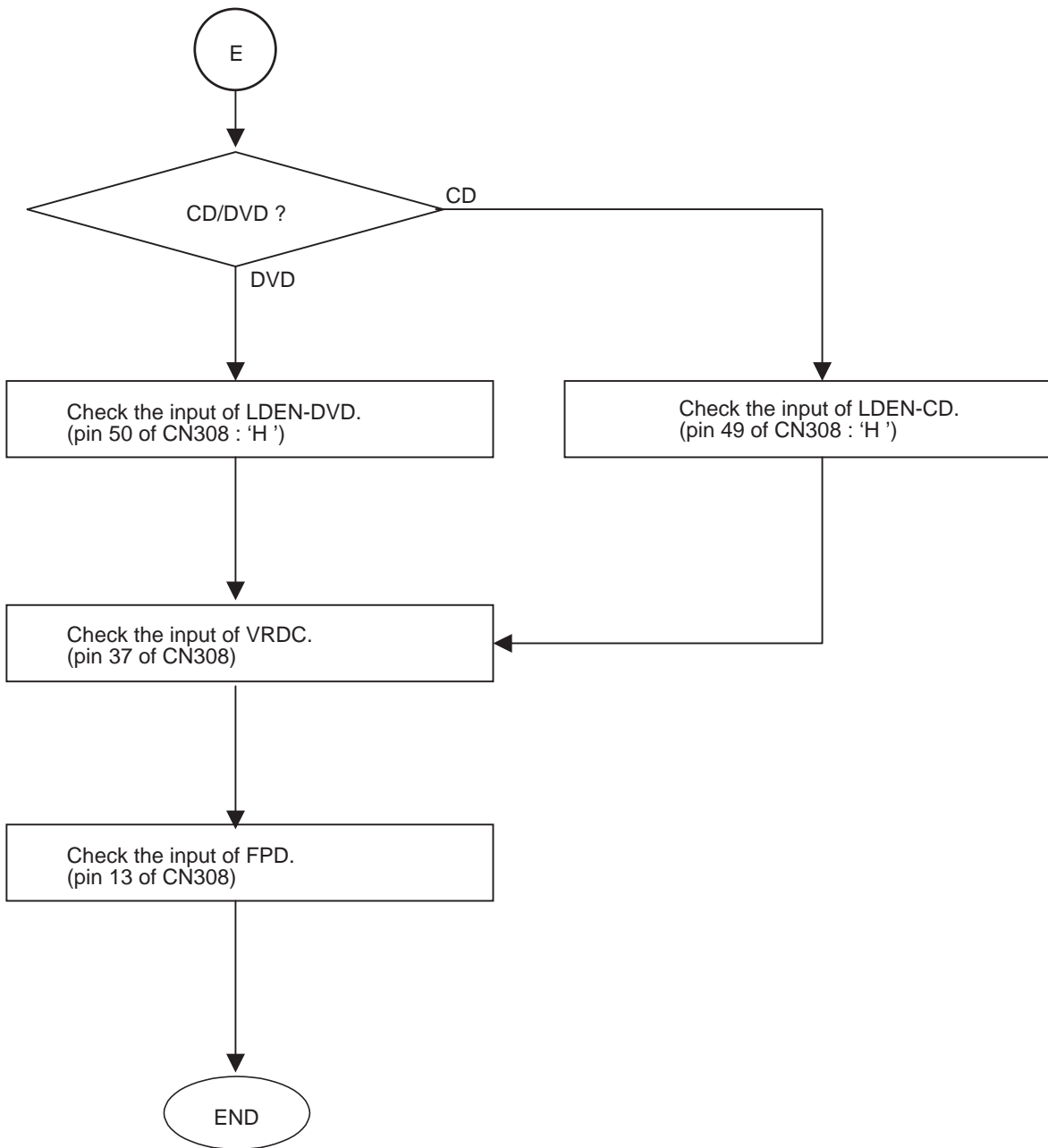

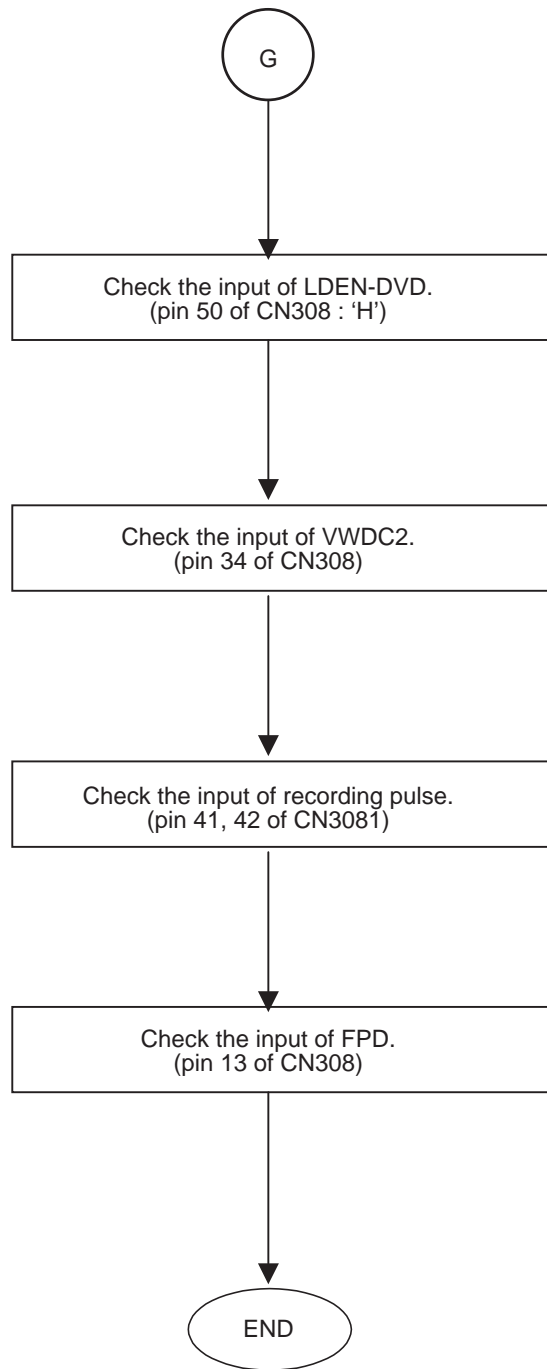
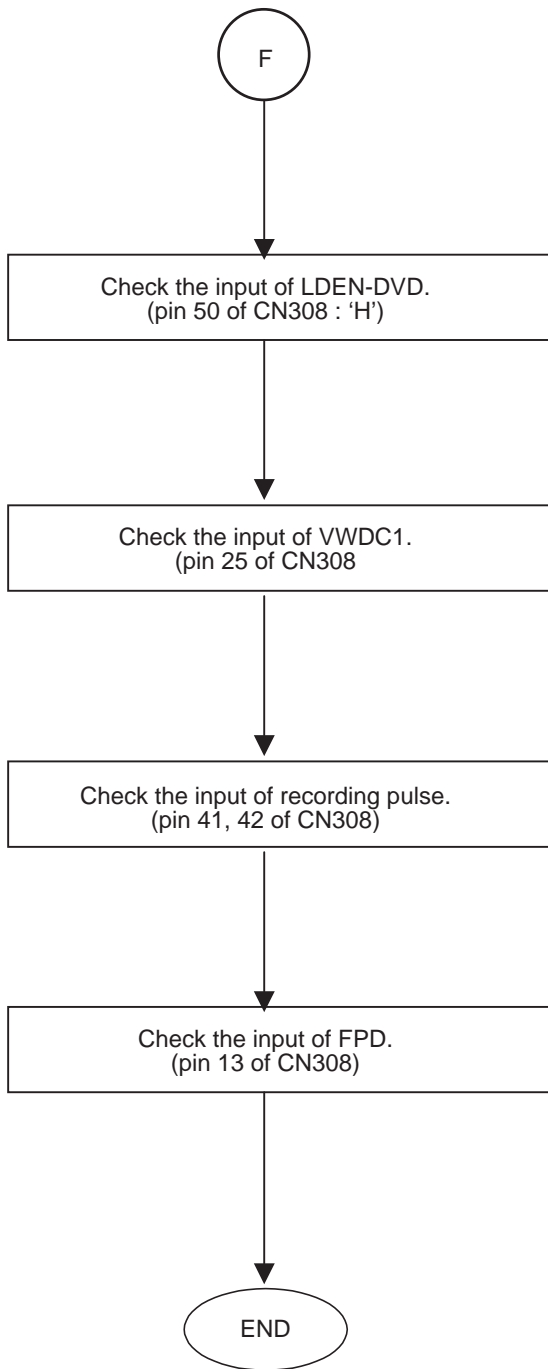

In case of writing fail.

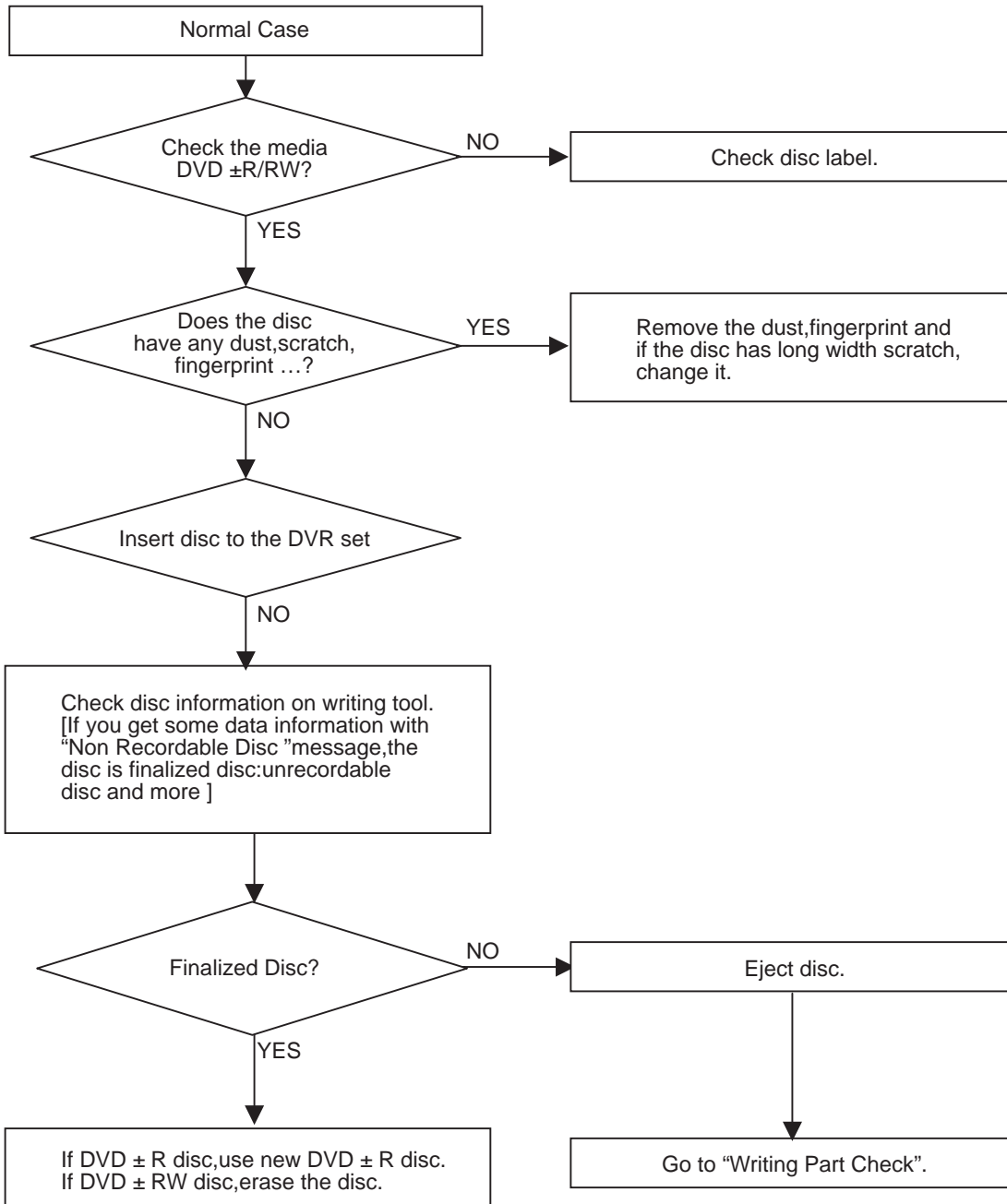

Writing Part Check

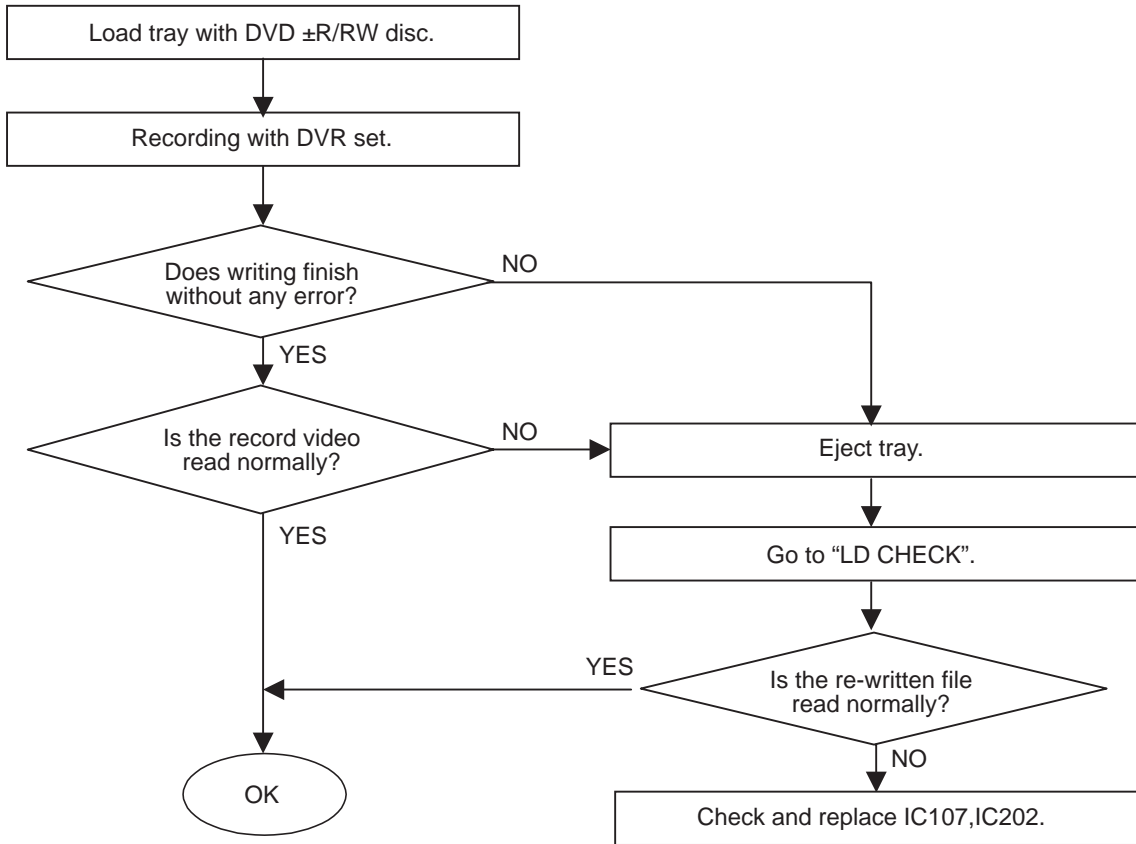

BLOCK DIAGRAMS

1. SERVO SYSTEM BLOCK DIAGRAM

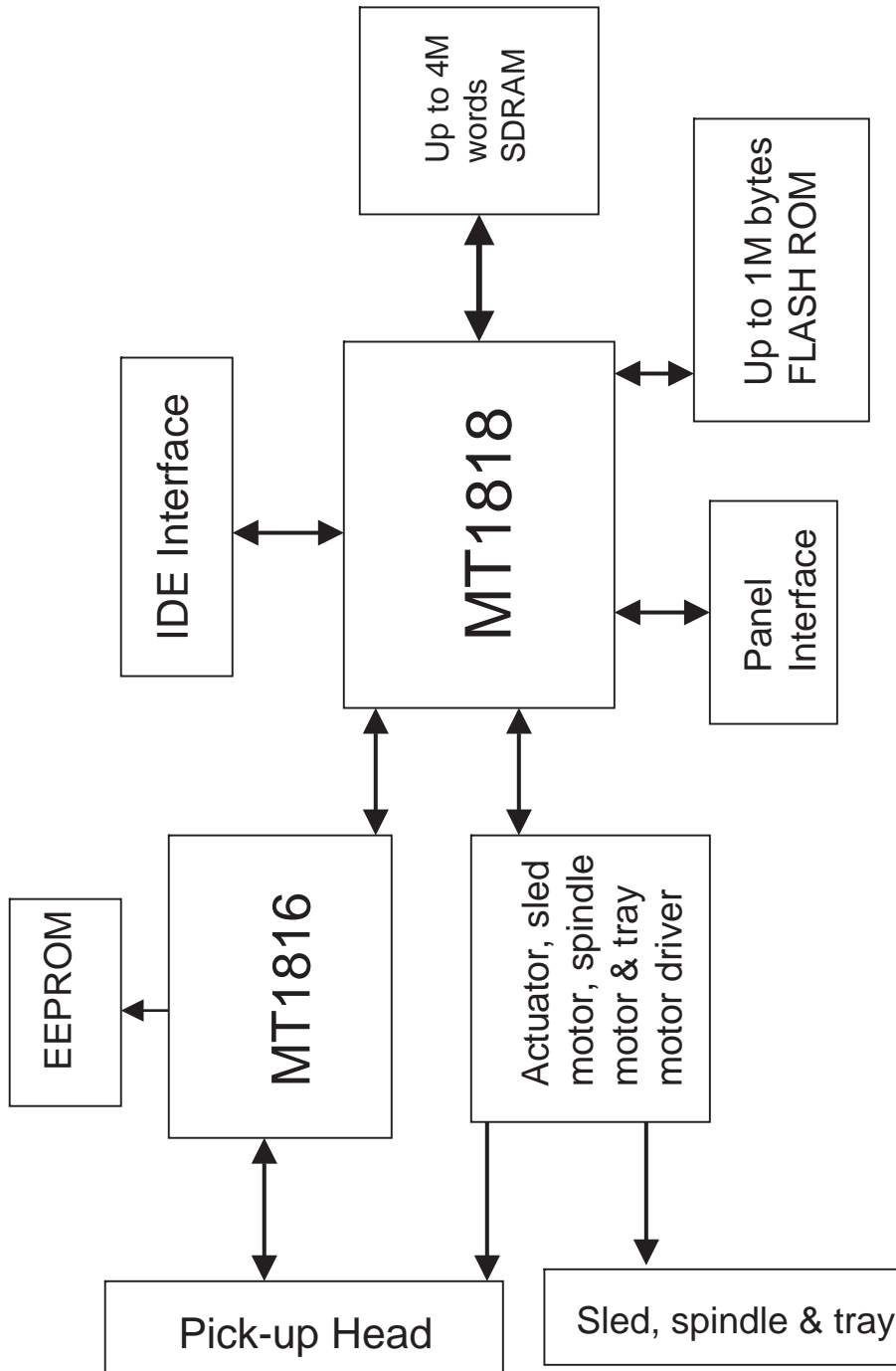

2. MT1816 BLOCK DIAGRAM

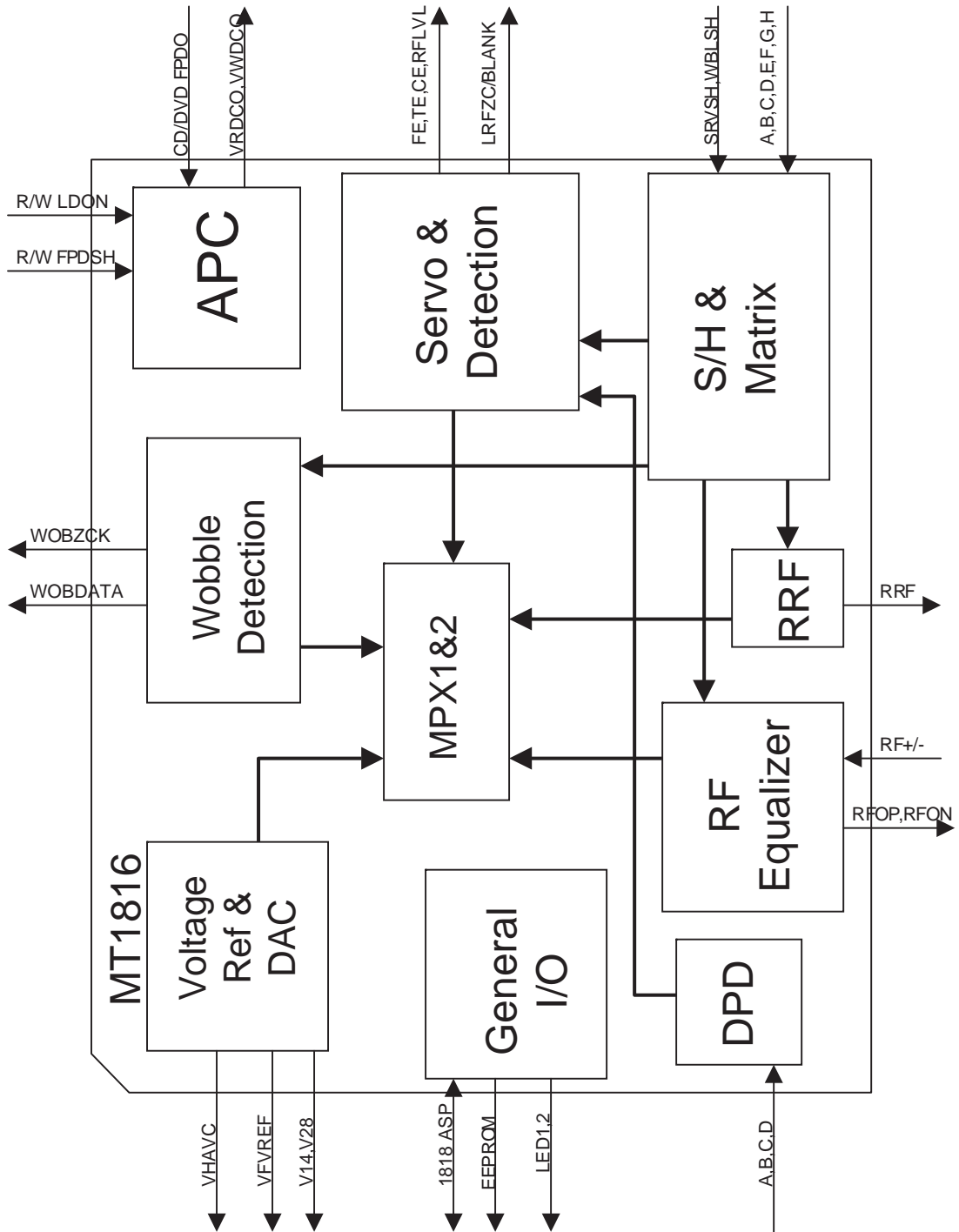

3. MT1818 BLOCK DIAGRAM

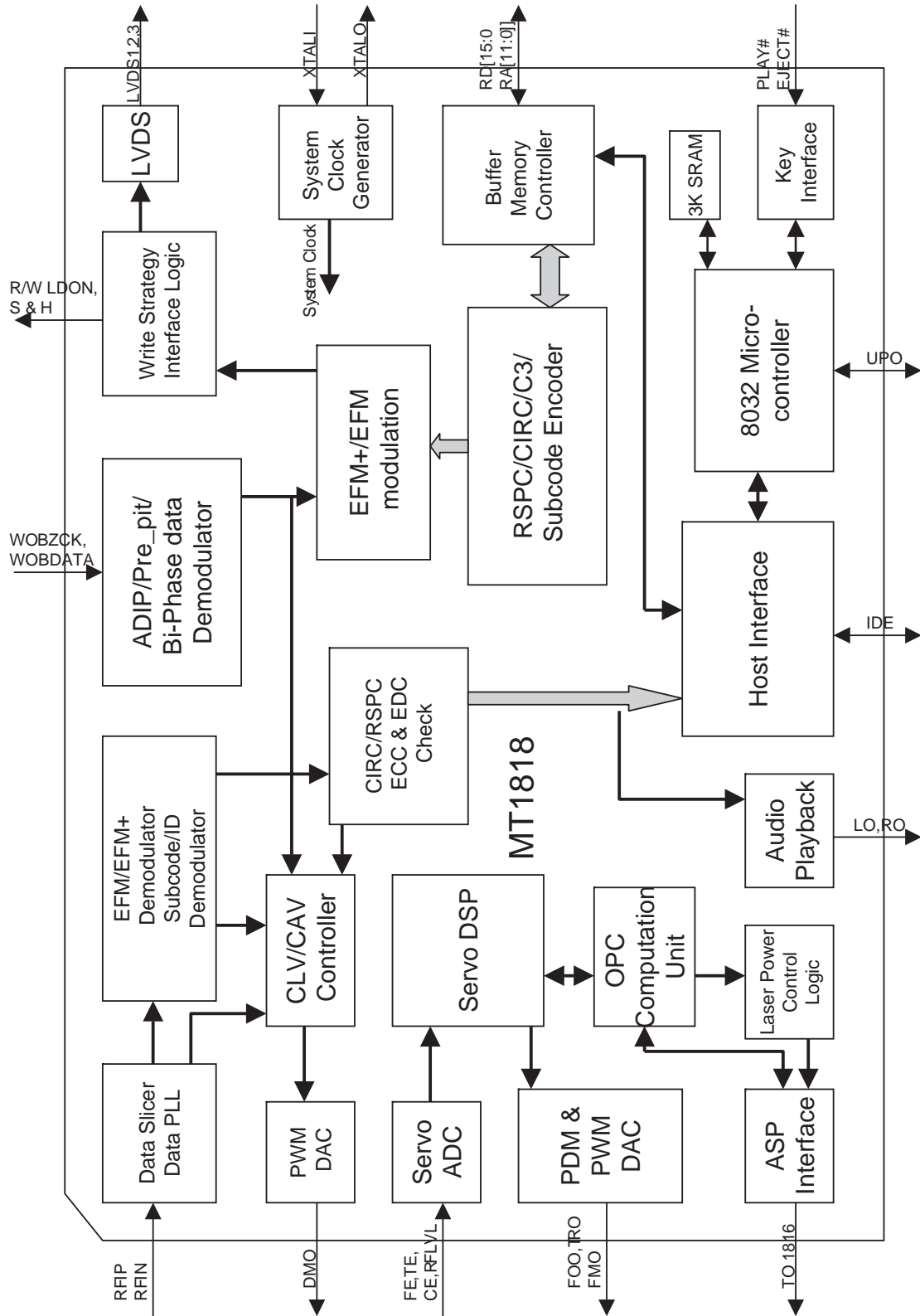

CIRCUIT DIAGRAMS

1. RF CIRCUIT DIAGRAM

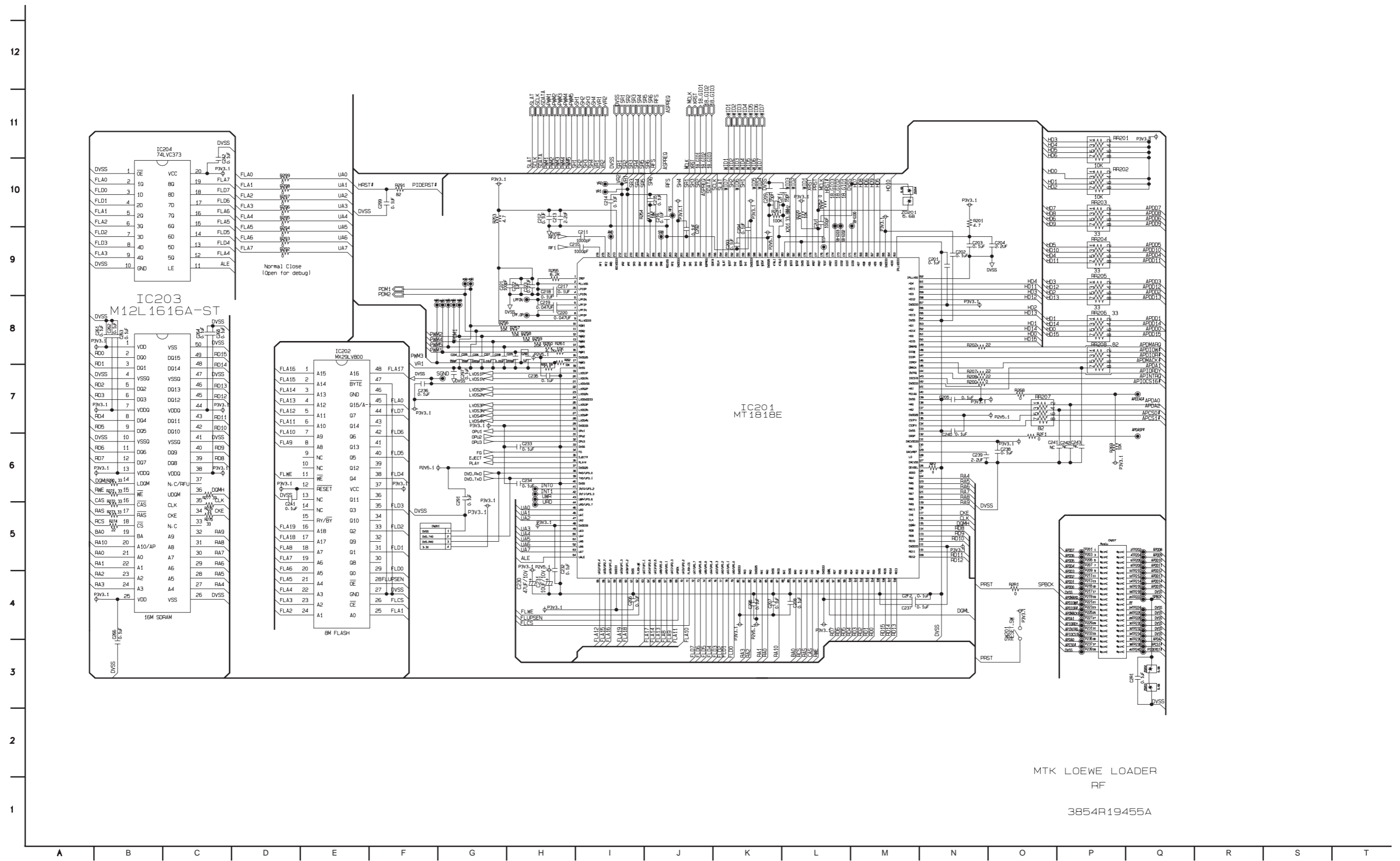

MTK LOEWE LOADER
RF
3854R19455A

2. DSP CIRCUIT DIAGRAM

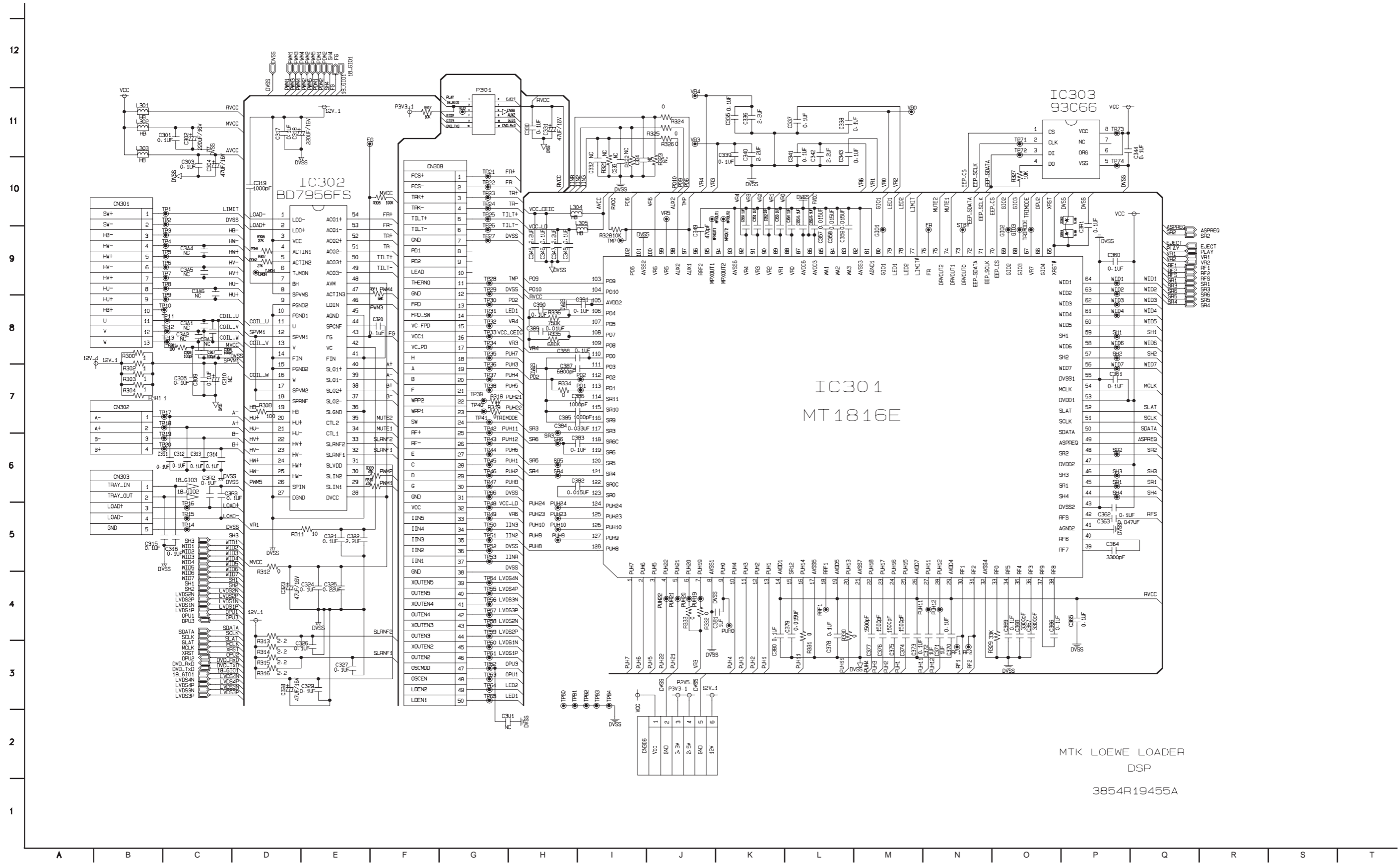

MTK LOEWE LOADER
DSP
3854R19455A

WIRING DIAGRAM

