

ULTIMATE HIGH FIDELITY STEREO COMPONENT

**RUHMANN**

**CL35/III**

CONTROL CENTER

**SERVICE MANUAL**

CIRCUIT DESCRIPTION

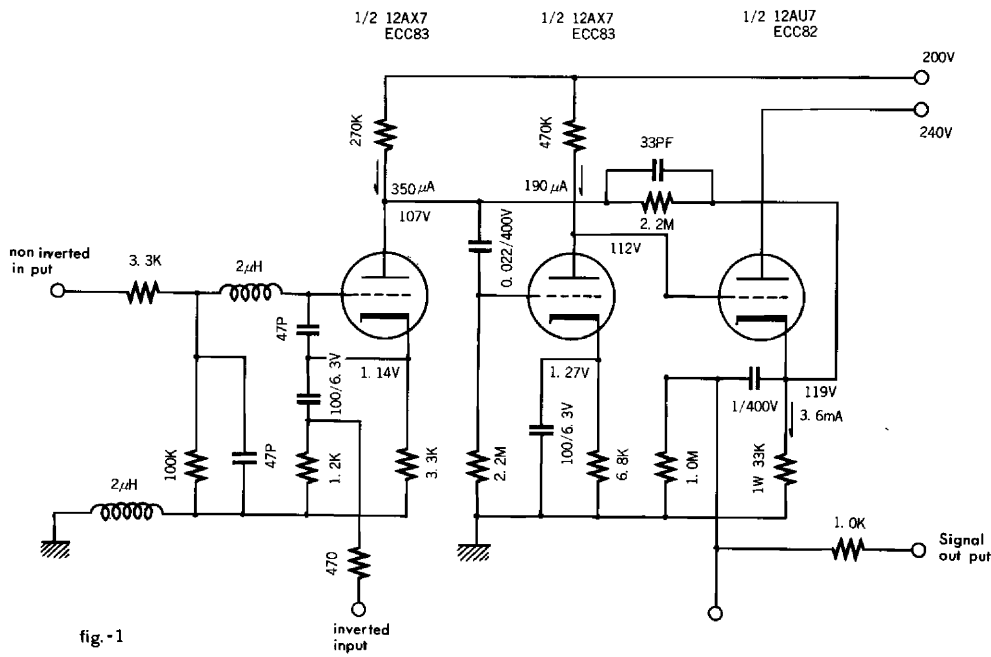

fig-1  
Equalizer Amplifier

Equalizer Amp.

The circuit is shown in the Fig. 1. This amp has not standard method of Feedback, about which special explanation is made hereunder.

Fig. 2 shows its concept, wherein A-3 means cathode-follower with its gain at 0dB. While A-2 has +39dB and therefore the gain is +39dB thru A-2 and A-3.

At A-1 the output impedance is 110K ohms by means of electric feedback from the cathode side. Local feedback by 2.2M ohms can be stipulated as the formula  $\text{Beta} = 1/19.8$  and amount of NF is 14dB. Therefore the gain is +25dB thru A-2 and A-3, and input impedance becomes 210K ohms.

At A-1 load is 120K ohms and gain is +32dB, and therefore the total gain is 57dB.

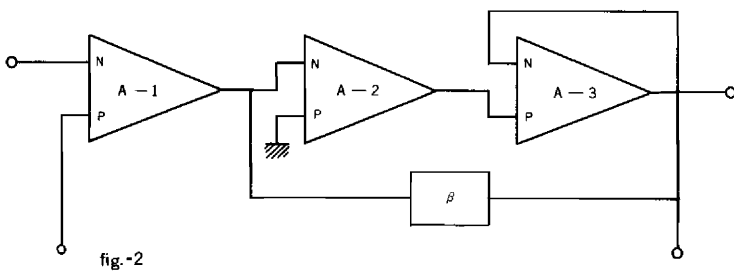

fig-2

Fig. 3 shows R.I.A.A. complex. The total NF shall not be levied below the cut-off frequency of 50Hz. In the case of triode it is possible to suppress the distortion below the sensing level under small signals. The present operation point lies at the total distortion balance.

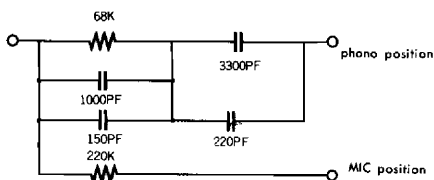

fig-3

This amp. plays the role of mic. amp. as well.

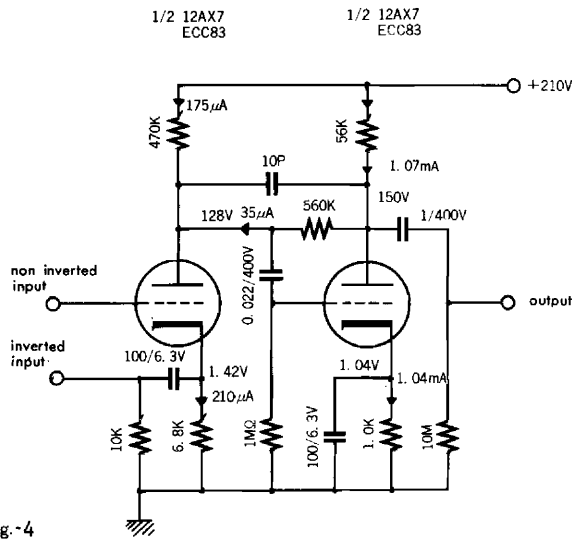

fig-4

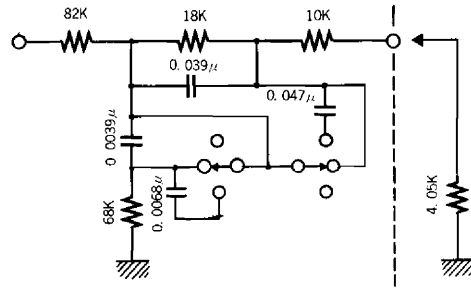

fig-5

Flat Amp.

Fig. 4 shows the circuit, where the 2nd stage is constituted by dual amps of local feedback. The feedback circuit is shown in Fig. 5. Low Frequency Trimmer operation is done by the feedback circuit. At the ⊕ position roll-off takes place at 100Hz and cut-off takes place at 250Hz, while at the ⊖ position cut-off commences at 100Hz and roll-off starts at 220Hz.

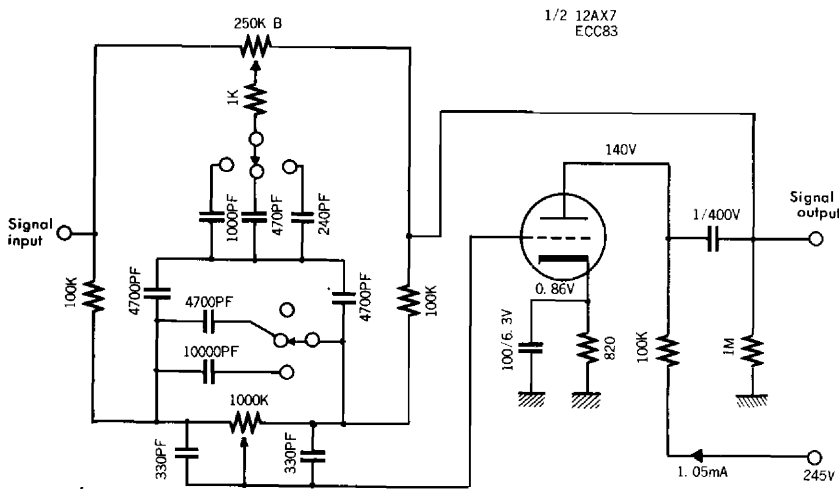

fig-6

Tone Control

Made of LUX's exclusive NF type. All circuits are shown in Fig. 6. This is standard tone control with LUX amps. Incidentally operation of tubes at this stage depends on distortion and level of grid current.

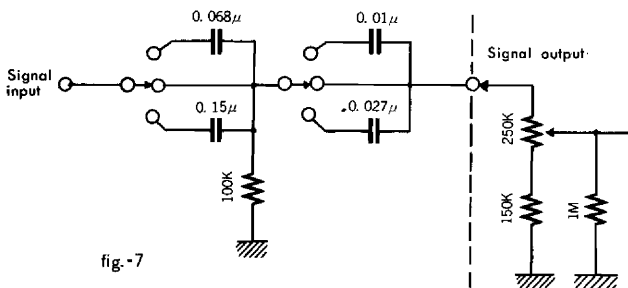

fig-7

Low Cut Filter

As per Fig. 7. this is -12dB/oct. filter composed by 2-stage coupling of CR. This filter frequency depends on the level set volume, and the standard point lies at the 5th decrement from the max. position (-6dB).

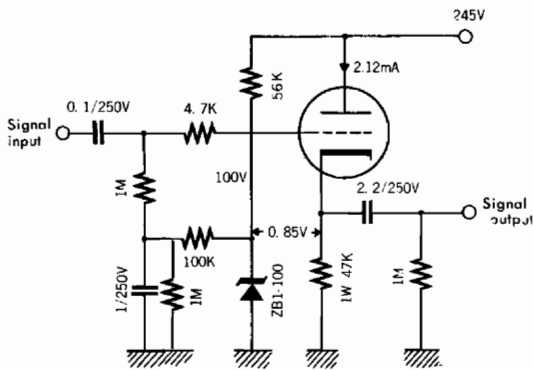

fig.-8

Output Amp.

Composed by cathode-follower as per Fig. 8. The bias is fixed at this stage. Noise of zener is reduced down to the allowable level by high cut filter.

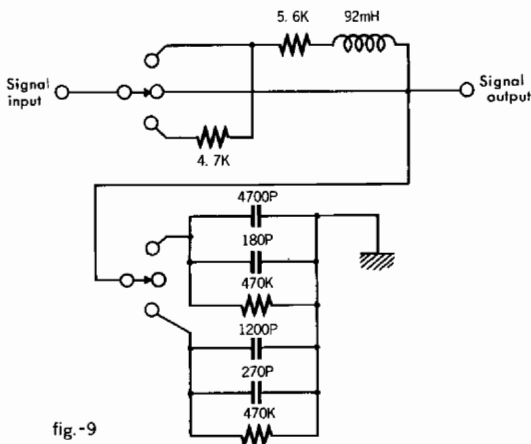

fig.-9

High Cut Filter

Shown by Fig. 9, and attenuates -12dB/oct. by means of LC. The filter frequency is decided in view of load and 100K ohms + 200pF (main input impedance and shield wire).

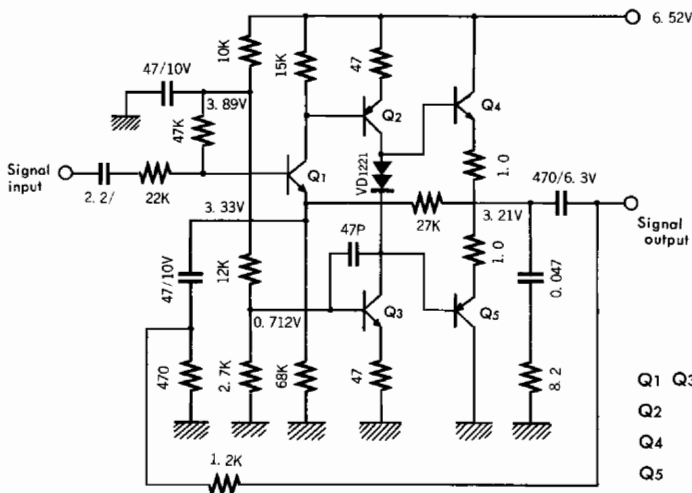

fig.-10

Headphone Amp.

Fig. 10 shows whole circuit, which is made by whole stage direct coupled pure complementary SEPP configuration. Q2 retains the fixed current load triggered by Q3 and yields the output of about 100mW into 8 ohms.

- Q1 Q3: 2SC1222
- Q2 : 2SA640
- Q4 : 2SC375
- Q5 : 2SA562

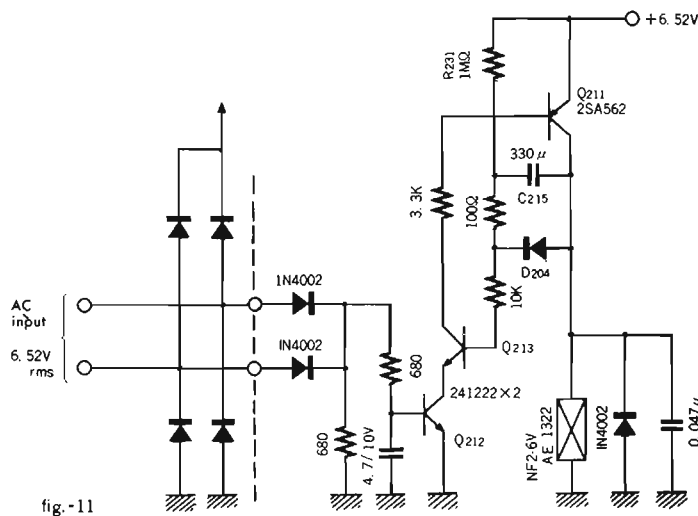

fig.-11

Time Delay Circuit

The circuit is shown by Fig. 11. Power supply section is common to headphone amp and pilot lamp.

Q212 is put into operation the instant the power is switched on. As to Q213 bias is gradually given on the base through R231 and C215. To activate it some 0.4V is needed. When the power supply is 100% 0.4V equals 6%. To charge 6%, T/CR is needed by 6% which corresponds to 24 sec. (CR = 400uF.Kohms).

Q211 is activated when Q213 is turned on, and relay functions to break allowing the Pre Out terminal to be open from short-circuiting.

Q212 is turned off the instant the power is switched off, and then Q213 and Q211 are turned off to let the relay contact make and short-circuited.

Thenafter the base current of Q213 is supplied by D204.

PB-667

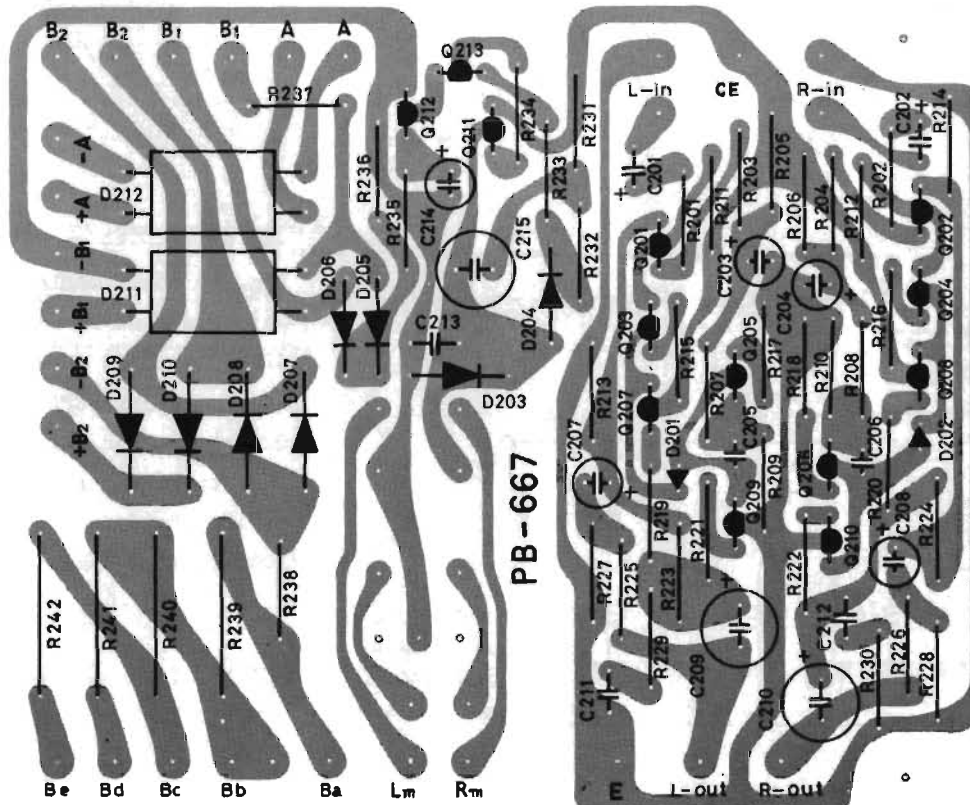

MODEL CL35/III REPLACEMENT PARTS LIST

PB-668/669

Description	TYPE	QUANTITY
1. Printed Circuit Board	PB-667	1
2. Diode	SD-1B	4
3. "	1N4002	3
4. "	M4E	2
5. "	1K188	1
6. Varistor	VD-1221	2
7. Transistor	2SA562Y	3
8. "	2SA640	2
9. "	2SC735Y	2
10. "	2SC1222E	6
11. Electrolytic	25V 4.7uF	1
12. "	10V 47 uF	4
13. "	6.3V 470uF	2
14. "	10V 330uF M (NON POLAR)	1
15. Tantalum	10V 2.2uF	2
16. Polyester Film	50V 0.047uF	3
17. Ceramic	50V 47pF	2
18. Resistor	10K +-5% 1W	2
19. "	2.2K "	2
20. "	1K "	1
21. "	270K " 1/2W	1
22. "	1M3 " 1/4W	1
23. "	68K "	1
24. "	47K "	2
25. "	27K "	2
26. "	22K "	2
27. "	15K "	2
28. "	12K "	2
29. "	10K "	2
30. "	3.3K "	3
31. "	2.7K "	1
32. "	1.2K "	2
33. "	680 "	2
34. "	470 "	2
35. "	100 "	1
36. "	47 "	4
37. "	8.2 "	2
38. "	1 "	5
39. Relay	6V 2 circuit transfer(AE1322)	1

1	Resistor	2.2M	+5%	1/2W	4
2	"	1 M	"	"	14
3	"	560K	"	"	2
4	"	470K	"	"	8
5	"	220K	"	"	2
6	"	150K	"	"	2
7	"	100K	"	"	8
8	"	82K	"	"	2
9	"	68K	"	"	4
10	"	56K	"	"	4
11	"	18K	"	"	2
12	"	10K	"	"	4
13	"	6.8K	"	"	4
14	"	5.6K	"	"	2
15	"	4.7K	"	"	2
16	"	3.3K	"	"	4
17	"	1.2K	"	"	2
18	"	1K	"	"	4
19	"	820	"	"	2
20	"	470	"	"	2
21	"	47K	"	1W	2
22	"	33K	"	"	2
23	"	270K	"	1/2W low noise	2
24	Metalised Film	400V	1 uF		4
25	"	400V	0.1uF		2
26	"	400V	0.022uF		4
27	"	250V	2.2uF		2
28	"	250V	1 uF		2
29	"	250V	0.1uF		2
30	Polyester Film	50 V	0.15uF		2
31	"	50 V	0.068uF		2
32	"	50 V	0.039uF		2
33	"	50 V	0.027uF		2
34	"	50 V	0.01uF		2
35	"	50 V	0.0039uF		2
36	Styrol	125V	3300pF		2
37	"	125V	1000pF		2
38	"	125V	220pF		2
39	"	125V	150pF		2
40	"	50 V	4700pF		2
41	"	50 V	1200pF		2
42	"	50 V	270pF		2
43	"	50 V	180pF		2
44	Ceramic	50 V	47pF		4
45	"	500V	33pF		2
46	"	500V	10pF		2
47	Zener Diode	100W 1W (ZB1-100)			2
48	Electrolytic	6.3V 100uF (tubler type)			10
49	Coil	92mH (7-1174)			2
50	"	2uH (L-01)			4
51	Printed Circuit Board	PB-668			1
52	"	PB-669			1

BLOCK DIAGRAM

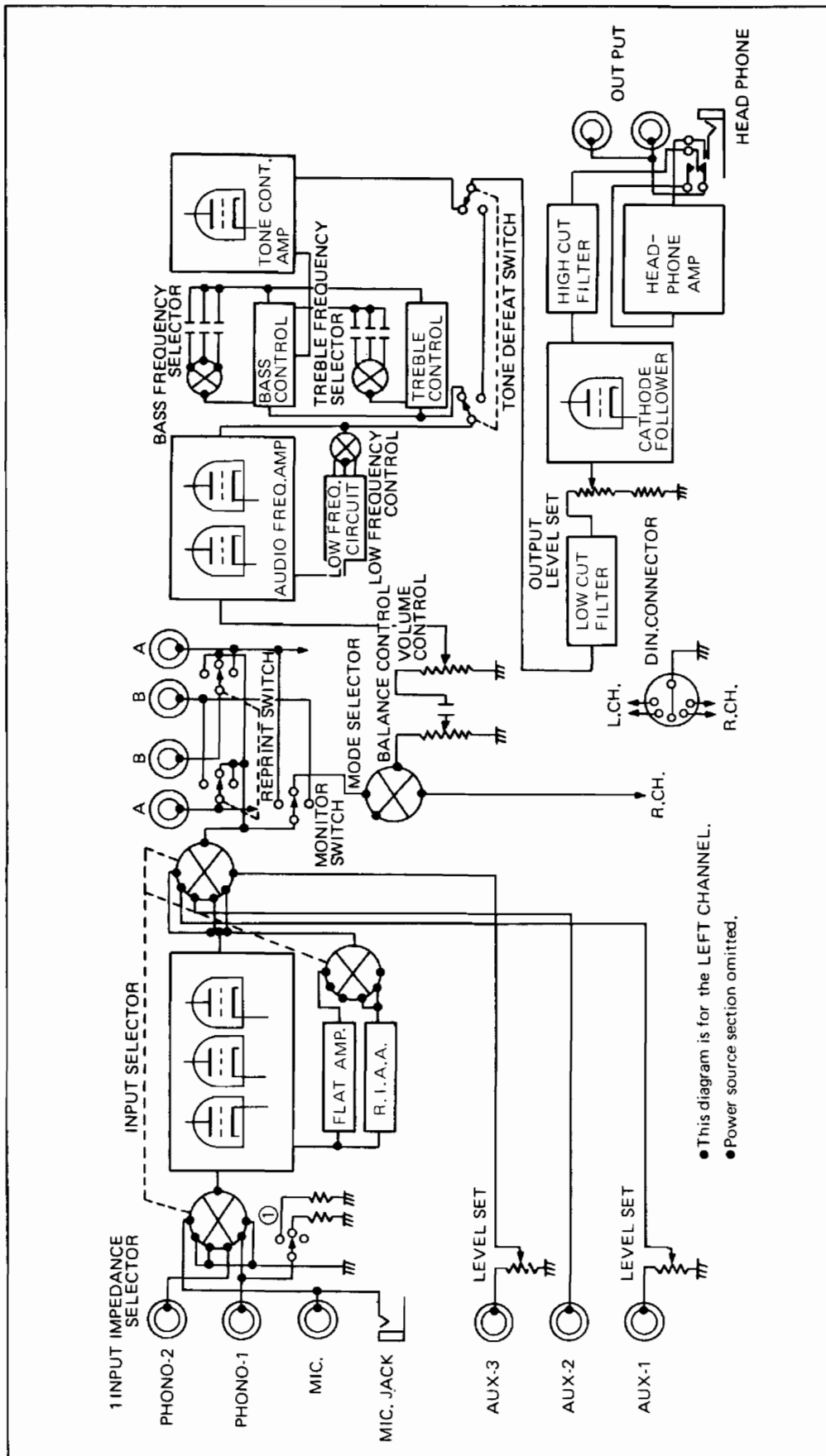

# SPECIFICATIONS

Tubes:	12AX7 (6), 12AU7 (1)
Frequency Response:	15Hz – 40,000Hz (–1dB)
T.H.D.:	no more than 0.06% (rated output: 2V)
Output Voltage:	Max. 15V (distortion 0.3%)
Output Impedance:	550-ohms
Input Sensitivity: (output ; 1V, output level max.)	phono-1 1.4mV phono-2 1.4mV aux-1 140mV (variable) aux-2 140mV aux-3 140mV (variable) microphone 0.7mV
Input Impedance:	phono-1 100K ohms, 50K ohms, 30K ohms phone-2 50K ohms aux-1 100K ohms aux-2 150K ohms aux-3 100K ohms microphone 50K ohms
S/N Ratio:	better than 64dB (phono-1 & 2) better than 77dB (aux-1 & 2 & 3) better than 60dB (microphone)
Equalizer:	R.I.A.A. (strandard deviation $\pm$ 0.3%)
Tone Control:	LUX type NF system with defeat position
Bass:	150Hz, 300Hz, 600Hz
Treble:	1.5KHz, 3KHz, 6KHz
Filter:	Low cut 25Hz, 60Hz High cut 7KHz, 12KHz
Low Frequency Trimmer:	100Hz – 800Hz ( $\pm$ 0.8dB, 250Hz)
Attenuator:	–20dB
Accessories:	Tape Monitor Circuit, Phono Input Impedance Selector, Socket for step-up transformer, Headphone Circuit
Dimensions:	476 (19-1/25'')W x 275(11'')D x 190 (7-3/5'')Hmm
Weight:	Net 12Kgs (26.40 lbs) Gross 14Kgs (30.8 lbs)

Specifications and appearance design subject to possible change without notice.



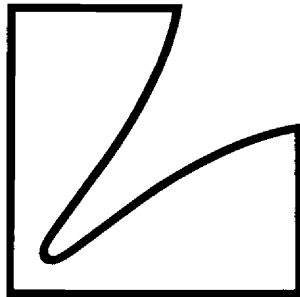

**LUX CORPORATION, JAPAN**

**HEAD OFFICE & FACTORY**  
1-8-31 NAGAHASHI, NISHINARI-KU OSAKA  
PHONE:632 0031 CABLE:LUXELECT OSAKA  
TELEX:J63694

**LUX AUDIO OF AMERICA LTD.**

200 Aerial Way, Syosset, New York 11791. U.S.A.  
PHONE: (516) 822-7070

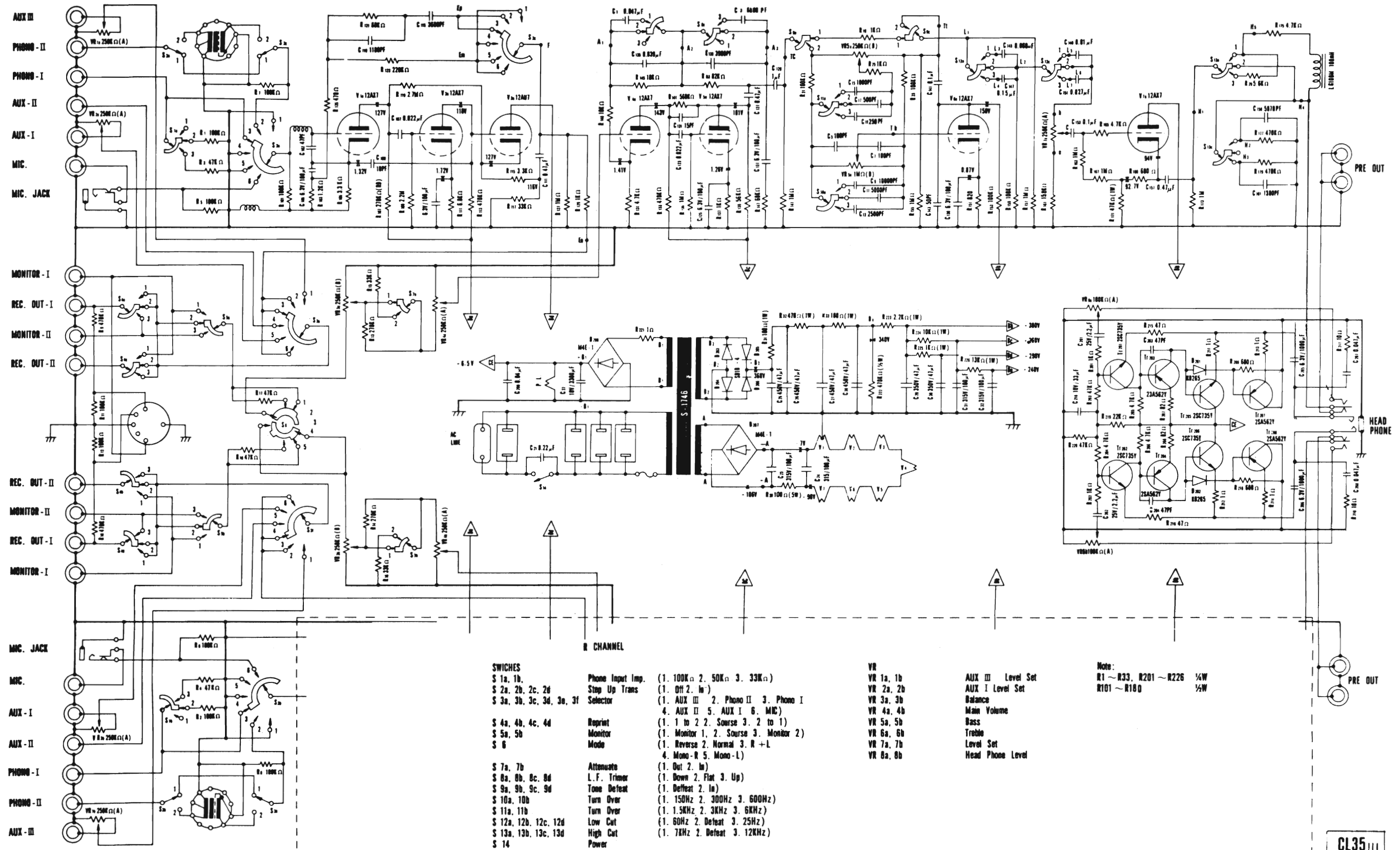

- SWITCHES**
- S 1a, 1b. Phone Input Imp.
  - S 2a, 2b, 2c, 2d. Stop Up Trans
  - S 3a, 3b, 3c, 3d, 3e, 3f. Selector
  - S 4a, 4b, 4c, 4d. Reprint
  - S 5a, 5b. Monitor
  - S 6. Mode
  - S 7a, 7b. Attenuate
  - S 8a, 8b, 8c, 8d. L.F. Trimer
  - S 9a, 9b, 9c, 9d. Tone Defeat
  - S 10a, 10b. Turn Over
  - S 11a, 11b. Turn Over
  - S 12a, 12b, 12c, 12d. Low Cut
  - S 13a, 13b, 13c, 13d. High Cut
  - S 14. Power

- Phone Input Imp.** (1. 100KΩ 2. 50KΩ 3. 33KΩ)  
**Stop Up Trans** (1. Off 2. In)  
**Selector** (1. AUX III 2. Phono II 3. Phono I 4. AUX II 5. AUX I 6. MIC)  
**Reprint** (1. 1 to 2 2. Source 3. 2 to 1)  
**Monitor** (1. Monitor 1, 2. Source 3. Monitor 2)  
**Mode** (1. Reversa 2. Normal 3. R + L 4. Mono-R 5. Mono-L)  
**Attenuate** (1. Out 2. In)  
**L.F. Trimer** (1. Down 2. Flat 3. Up)  
**Tone Defeat** (1. Defeat 2. In)  
**Turn Over** (1. 150Hz 2. 300Hz 3. 600Hz)  
**Turn Over** (1. 1.5KHz 2. 3KHz 3. 6KHz)  
**Low Cut** (1. 60Hz 2. Defeat 3. 25Hz)  
**High Cut** (1. 7KHz 2. Defeat 3. 12KHz)  
**Power**

- VR**
- VR 1a, 1b. AUX III Level Set
  - VR 2a, 2b. AUX I Level Set
  - VR 3a, 3b. Balance
  - VR 4a, 4b. Main Volume
  - VR 5a, 5b. Bass
  - VR 6a, 6b. Treble
  - VR 7a, 7b. Level Set
  - VR 8a, 8b. Head Phone Level

**Note:**  
 R1 ~ R33, R201 ~ R226 1/4W  
 R101 ~ R180 1/2W

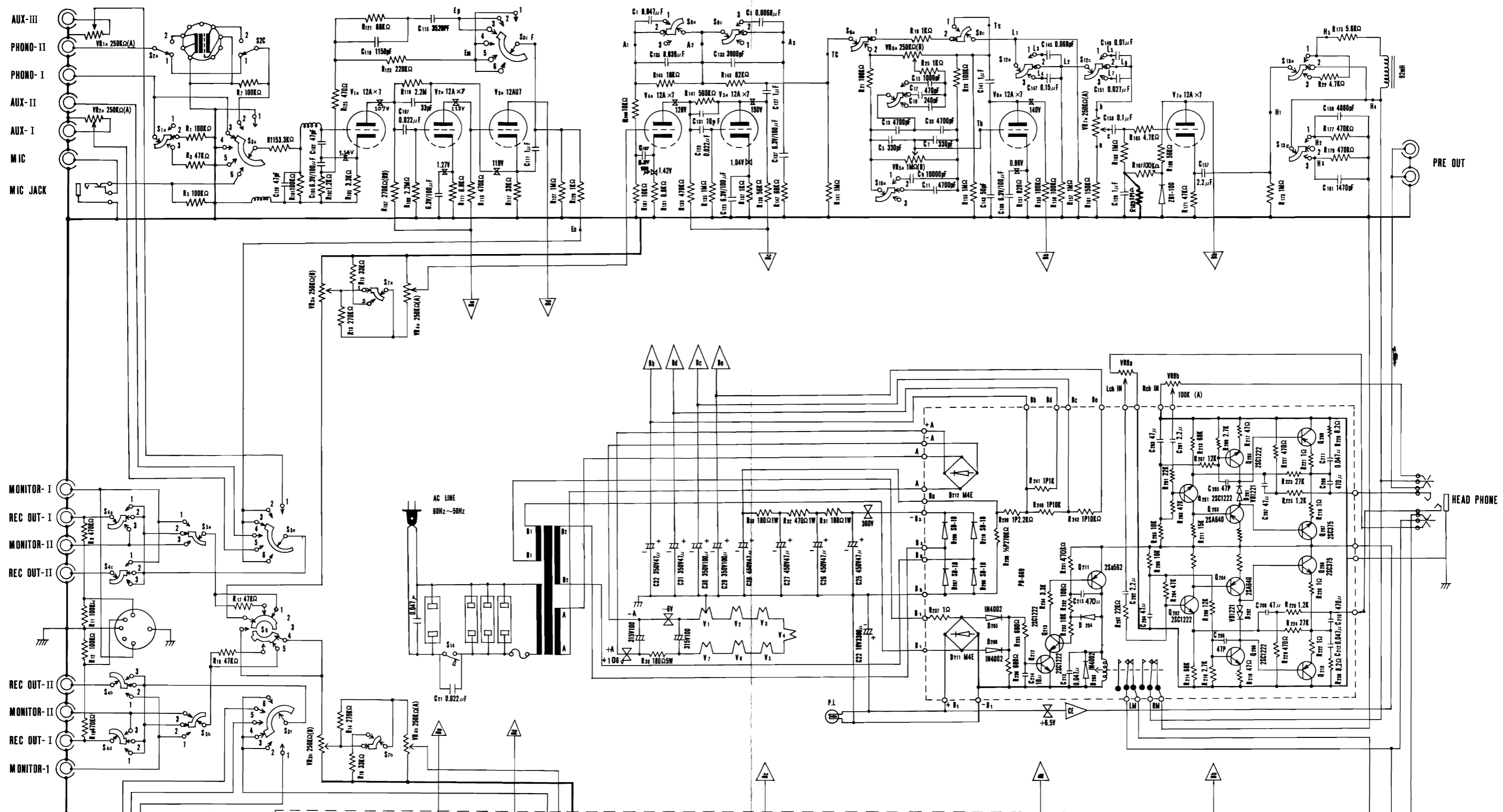

- S1 a, 1b, Phono Input Imp (1.100KΩ 2.50K 3.33K)
- S2 a, 2b, 2c, 2d, Stop Up Trans (1.1n 2.0H)
- S3 a, 3b, 3c, 3d, 3e, 3f, Selector (1.AuxIII, 2.PhonoII, 3.PhonoI, 4.AUXII, 5.AUXI, 6.MIC)
- S4 a, 4b, 4c, 4d, Reprint (1.No2, 2.Source, 3.Tot)
- S5 a, 5b, Monitor (1.Monitor1, 2.Source, 3.Monitor2)
- S6 Attenuate (1.Reverse, 2.Normal, 3.R+L, 4.MonoR, 5.MonoL)
- S7 a, 7b, L.F.Trimer (1.0n, 2.1n)
- S8 a, 8b, 8c, 8d, Tone Defeat (1.0n, 2.1n)
- S8 a, 8b, 8c, 8d, Turn Over (1.Down, 2.Flat, 3.Up)
- S10 a, 10b, Turn Over (1.0n, 2.1n)
- S11 a, 11b, Low Cut (1.150Hz, 2.300Hz, 3.600Hz)
- S12 a, 12b, 12c, 12d, High Cut (1.1.5KHz, 2.3KHz, 3.6KHz)
- S13 a, 13b, 13c, 13d, High Cut (1.60Hz, 2.Defeat, 3.25Hz)
- S14 Power (1.7KHz, 2.Defeat, 3.12Hz)

- VR 1a, 1b AUX III Level Set
- VR 2a, 2b AUX I Level Set
- VR 3a, 3b Balance
- VR 4a, 4b Main Volume
- VR 5a, 5b Bass
- VR 6a, 6b Treble
- VR 7a, 7b Level Set
- VR 8a, 8b Head Phone Level

PRE OUT

HEAD PHONE

PRE OUT