

SERVICE MANUAL

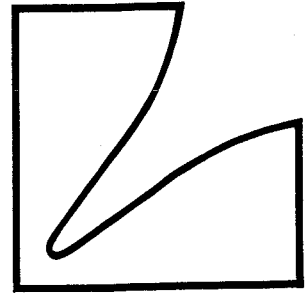

Compact Disc Player

D-117

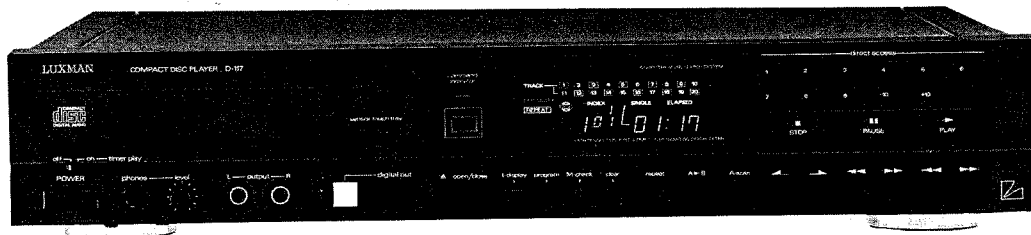

Contents

Specifications	2
Parts Locations and Disassembly Instructions	3 to 4
Adjustment Procedures	5 to 8
Adjustment Locations	9
Block Diagram	10
Parts Layout on P. C. Boards and Wiring Diagram (1/2) (JA, AD and UZ model only)	11 to 13
Parts Layout on P. C. Boards and Wiring Diagram (2/2) (UQ model only)	14 to 16
Schematic Diagram (1/2)	17 to 19
Schematic Diagram (2/2)	20 to 22
Electrical Parts List	23 to 27
Cabinet Assembly Parts List	28
Exploded View (Cabinet)	29 to 30
Exploded View (CD Mechanism)	31 to 32
CD Mechanism Assembly Parts List	33
Packing Assembly Parts List	34
Packing Method View	34
Semi-Conductor Lead Identifications	35 to 43

Specifications

CD SECTION

Systems	Optical (Compact Disc System)
Quantizing Bit Number	16 Bit Linear System
Channels	2 Channels, Stereo
Pick-up	Semiconductor Laser Pick-up
Output Voltage	2V \pm 1dB
Frequency Response	4~20kHz \pm 1dB
T.H.D (1kHz)	0.008%
S/N	91dB
Dynamic Range	88dB
Separation (1kHz)	82dB
Head-phone Output Voltage (1kHz, 10dB/8 ohm)	300mV
Power Supply	AC100V, 50/60Hz (JA Model only) AC120/220/240V, 50Hz (AD Model only) AC120V, 60Hz (UZ and UQ Model only)
Power Consumption	15W
Semiconductors	24 IC's, 26 Transistors, 2 FETs, 10 Diodes, 8 Zener Diodes (JA, AD and UZ Model only) 24 IC's, 25 Transistors, 2 FETs, 10 Diodes, 8 Zener Diodes (UQ Model only)
Dimension (W \times H \times D)	438 \times 85 \times 314mm
Weight	5kg

COMPACT DISC

Track Pitch	1.6 μ m
Modulation Frequency	44.1kHz
Transfer Rate	4.3218M Bit/sec.
Dimension	120 \times 1.2mm

NOTE : Due to continuing product improvement, specifications and design are subject to change without notice.

Parts Locations and Disassembly Instructions

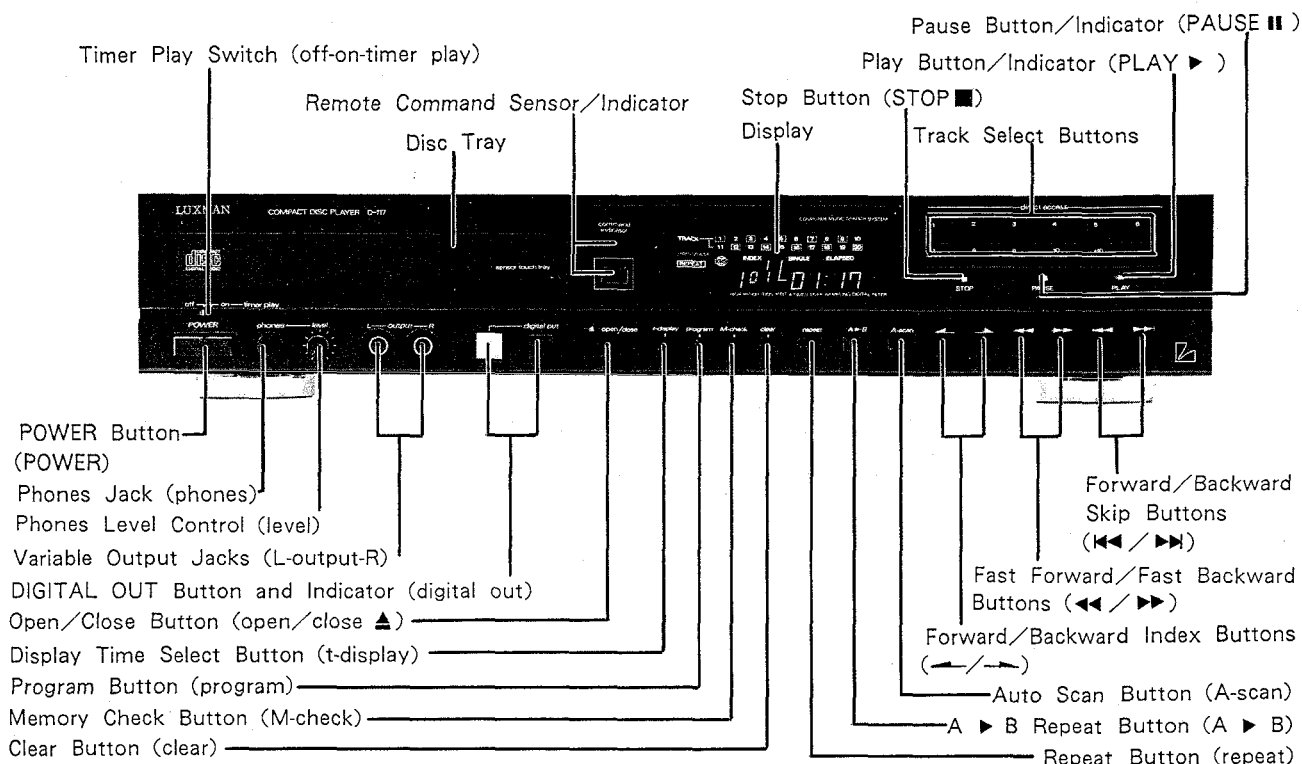

Figure 1

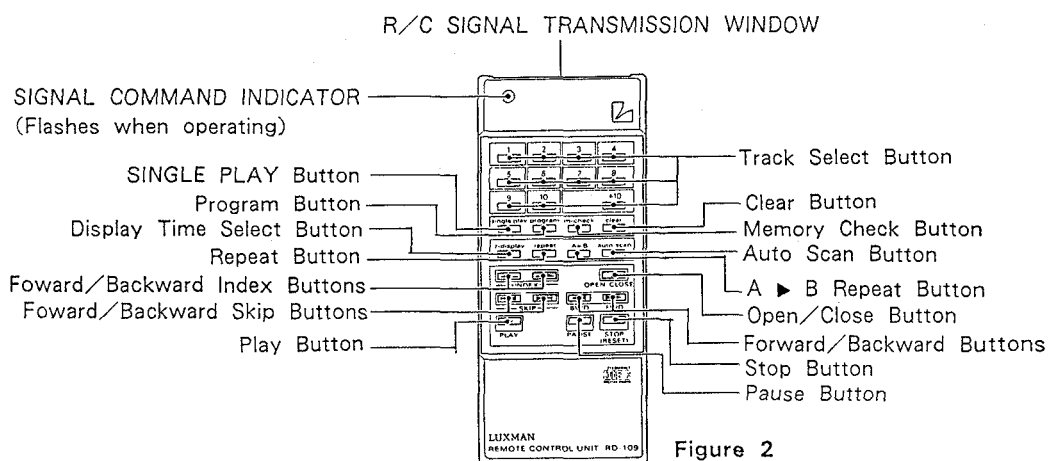

Figure 2

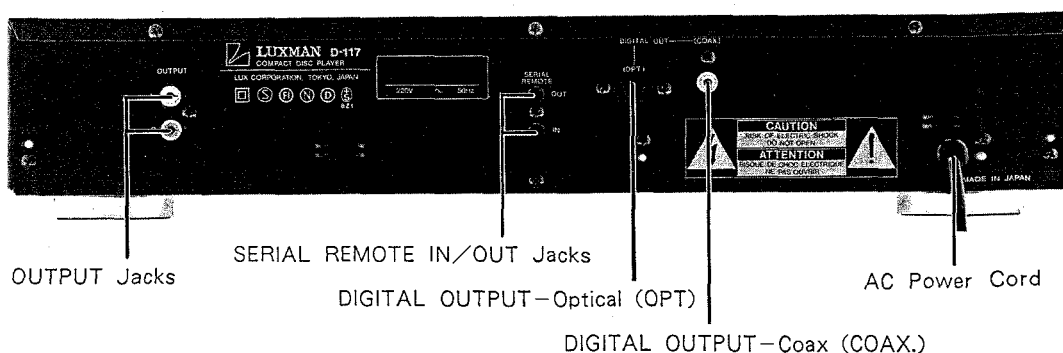

Figure 3

1. Removal of CD Mechanism

- (1) Open the disc tray.
- (2) Remove the panel tray in the arrow direction as shown in Figure 5.
- (3) Remove five screws marked "O" as shown in Figure 4.
- (4) Disconnect all wires from the CD Mechanism.

1. CDメカニズムの外し方

- (1) ディスク・トレイを引き出します。
- (2) トレー・パネルを上へ引き上げてディスク・トレイから外します。(5図参照)
- (3) 5本のネジ (O印) を外します。(4図参照)
- (4) CDメカニズムに接続している全てのリード線を外します。

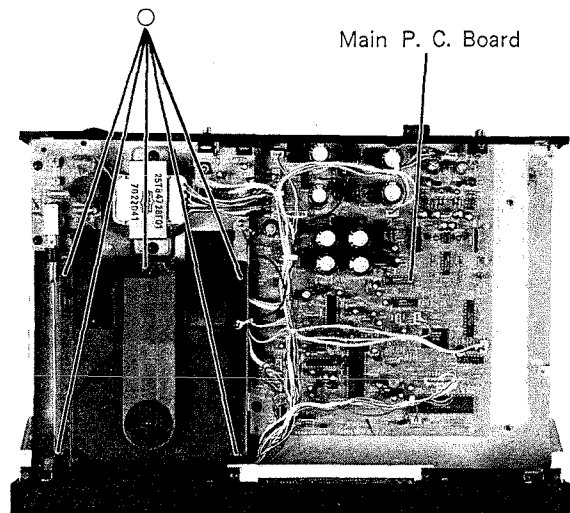

Figure 4
< 図4 >

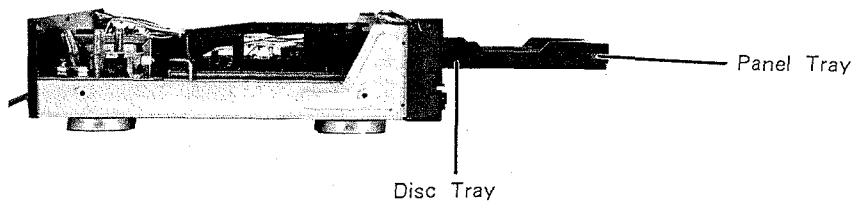

Figure 5
< 図5 >

2. Removal of FL/KEY Board P. C. Board

- (1) After removal of front panel, remove thirteen hooks as shown in Figure 6.
- (2) Disconnect one connector from the Main P. C. Board.

2. FL・キーボード基板

- (1) フロント・パネルをセットから外してから、13ヶ所のフックを外します。(6図参照)。
- (2) メイン基板とFL・キーボード基板を接続しているコネクターを全て外します。

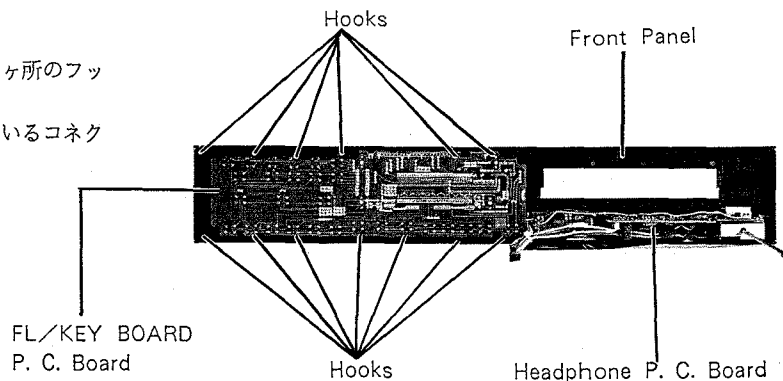

Figure 6
< 図6 >

Adjustment Procedures

1. CD SECTION (1) Connections

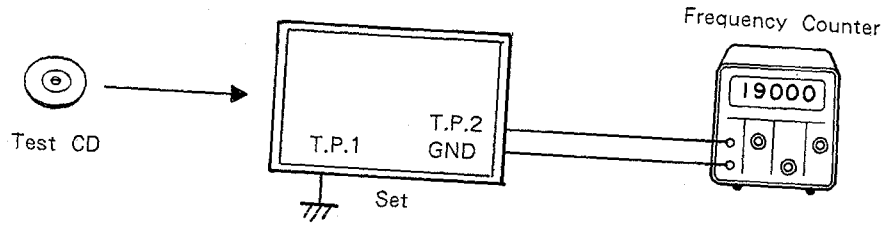

Figure 7

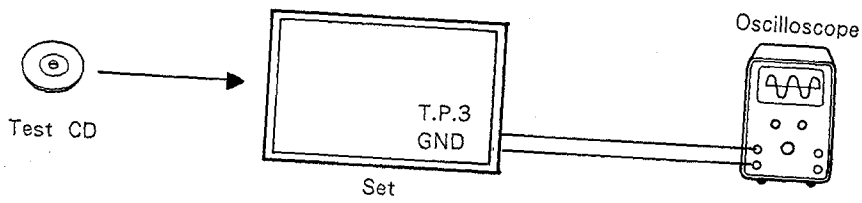

Figure 8

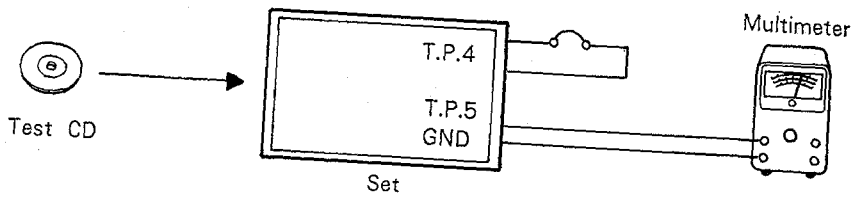

Figure 9

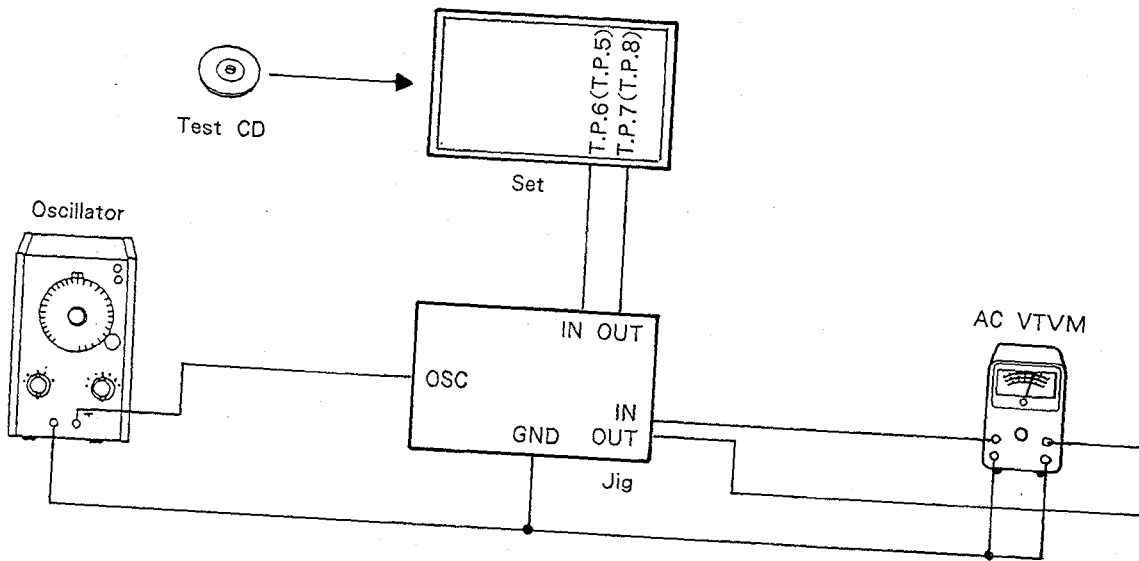

Figure 10

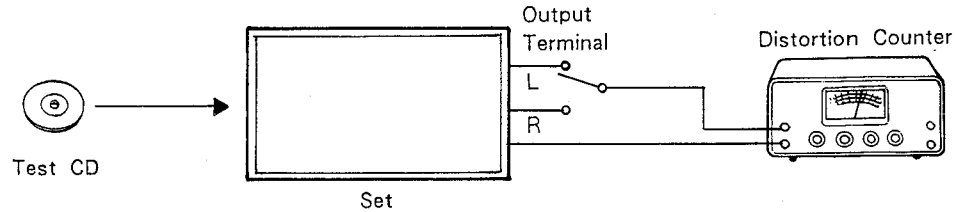

Figure 11

(2) Adjustment Procedures

Step	Description	Connection	Oscillator	Test Point	Adjustment
1	VCO Adjustment	Figure 7	—	T.P.1 T.P.2	Connect T.P.1 to ground and adjust VR1303 so that the frequency is $8.643\text{MHz} \pm 10\text{kHz}$.
2	Focus Bias Adjustment	Figure 8	—	T.P.3	Adjust VR1202 for the oscilloscope waveform to show maximum.
3	Tracking Error Balance Adjustment	Figure 9	—	T.P.4 T.P.5	Shortcircuit T.P.4, turn VR1301 fully counter-clockwise and adjust VR1201 so that the voltage is $0 \pm 50\text{mV}$. After adjustment set VR1301 at approximately its center position.
4	Tracking Gain Adjustment	Figure 10	1kHz 200mV	T.P.6 T.P.7	Adjust VR1302 so that two arms of the valve voltmeter just meet each other.
5	Focus Gain Adjustment	Figure 10	1kHz 200mV	T.P.5 T.P.8	Adjust VR1301 so that two arms of the valve voltmeter just meet each other.
6	Distortion Adjustment	Figure 11	—	Output Terminal	Adjust VR1401 for distortion to be minimum.

調整方法

1. コンパクト・ディスク

(1) 接続図

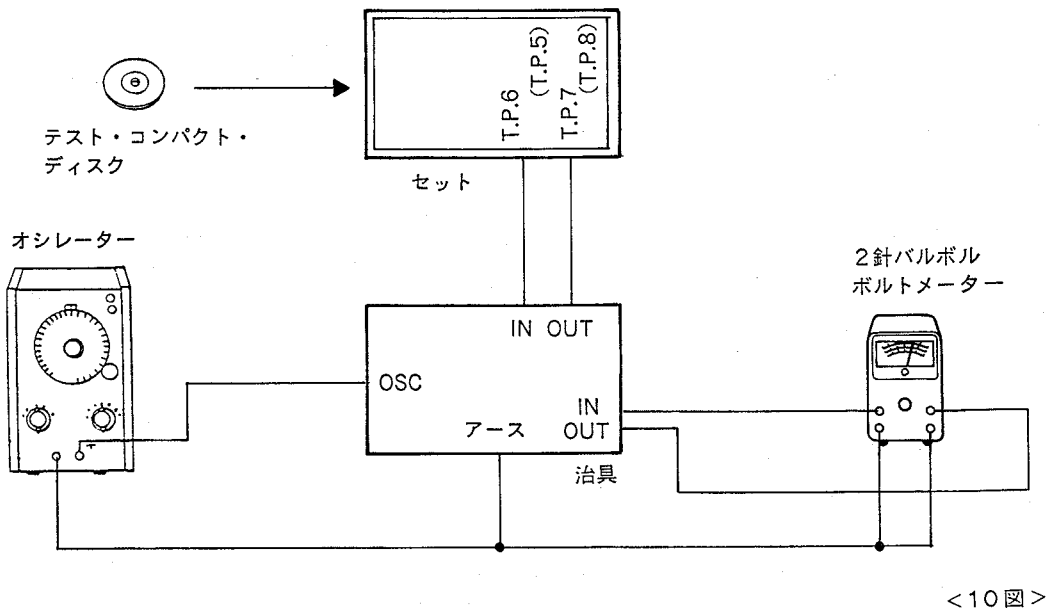
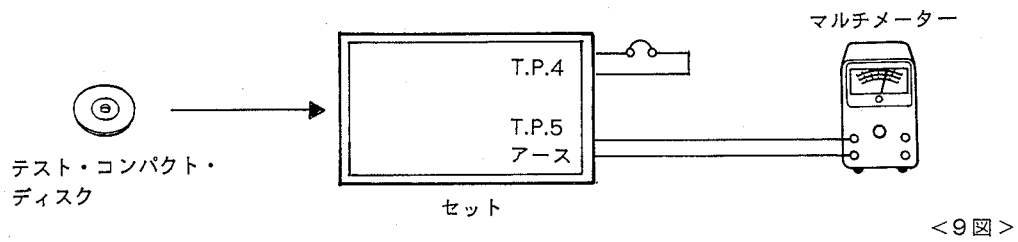
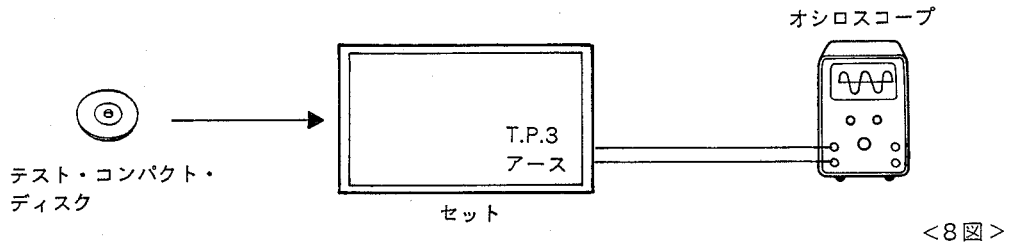
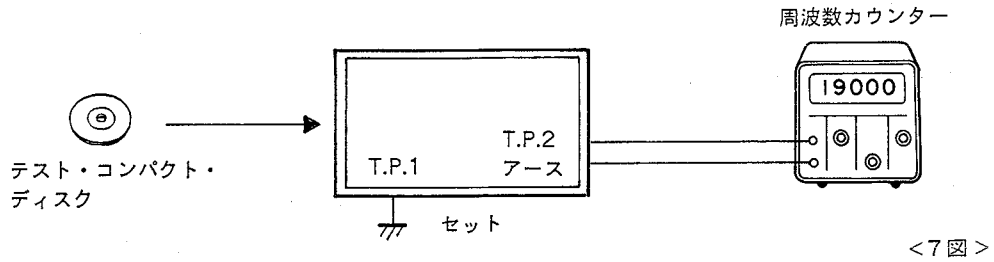

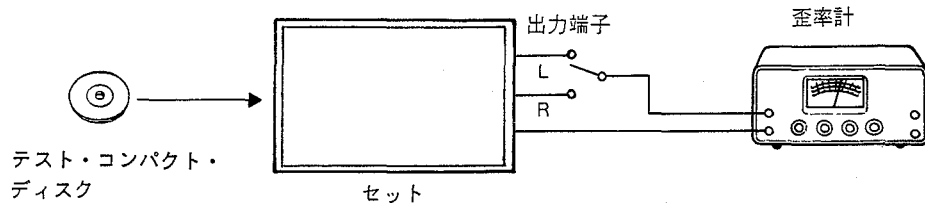

<11 図>

(2) 調整方法

順序	調整項目	接続図	オシレーター	テストポイント	調整方法
1	VCO調整	7 図	-	T.P.1 T.P.2	T.P.1をアースに落とし、周波数が8.643MHz±10kHzになる様にVR1303で調整します。
2	フォーカス バイアス調整	8 図	-	T.P.3	オシロスコープの波形が最大になる様にVR1202で調整します。
3	トラッキングエラー バランス調整	9 図	-	T.P.4 T.P.5	T.P.4をショートしてVR1301を左にしぼり、電圧が0V±50mVになる様にVR1201で調整します。調整後VR1301を中央付近にもどす事。
4	トラッキング ゲイン調整	10 図	1kHz 200mV	T.P.6 T.P.7	2針バルボルの針が重なる様にVR1302で調整します。
5	フォーカス ゲイン調整	10 図	1kHz 200mV	T.P.5 T.P.8	2針バルボルの針が重なる様にVR1302で調整します。
6	歪率調整	11 図	-	出力端子	出力の歪率が最小になる様にVR1401で調整します。

Adjustment Locations (Main P. C. Board)

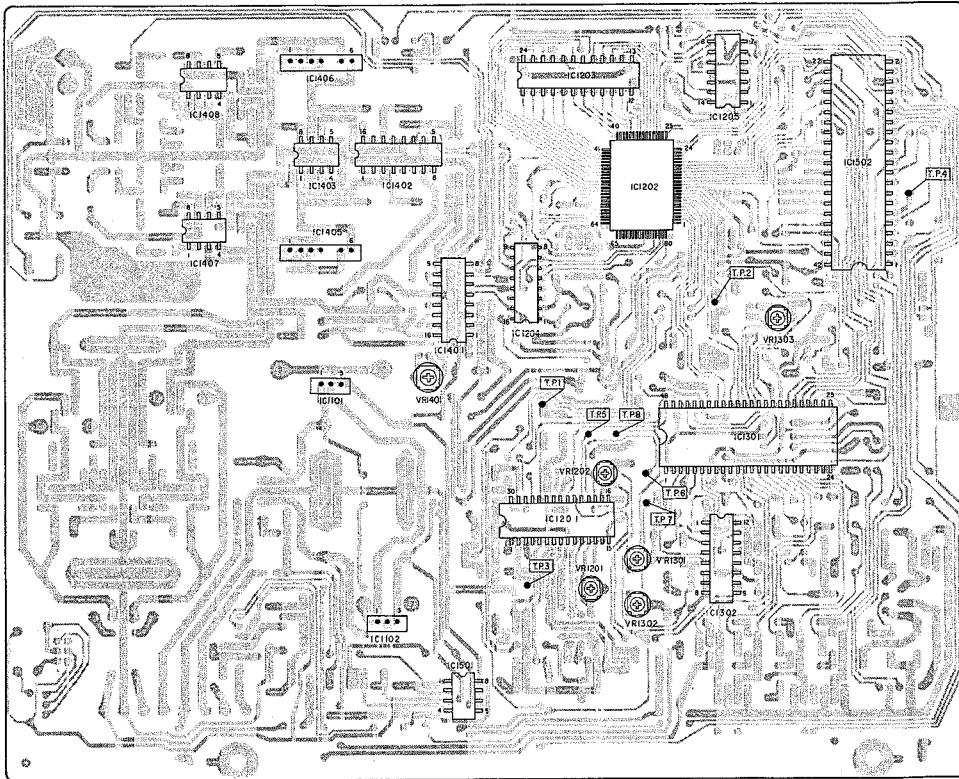

JA, AD and UZ Model Only

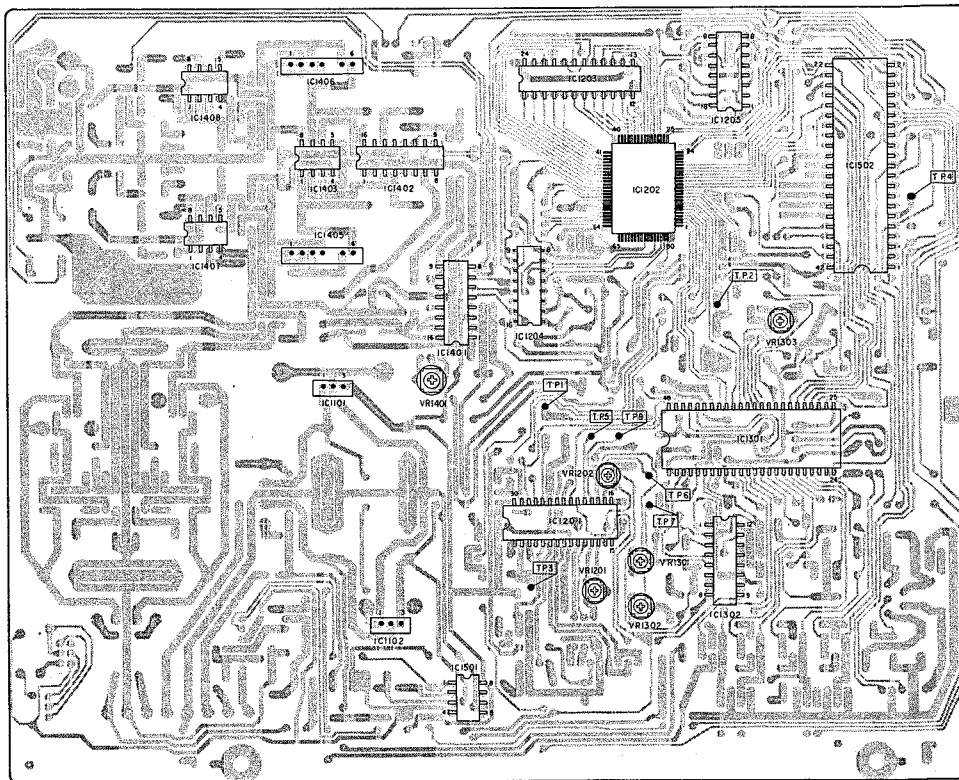

UQ Model Only

Block Diagram

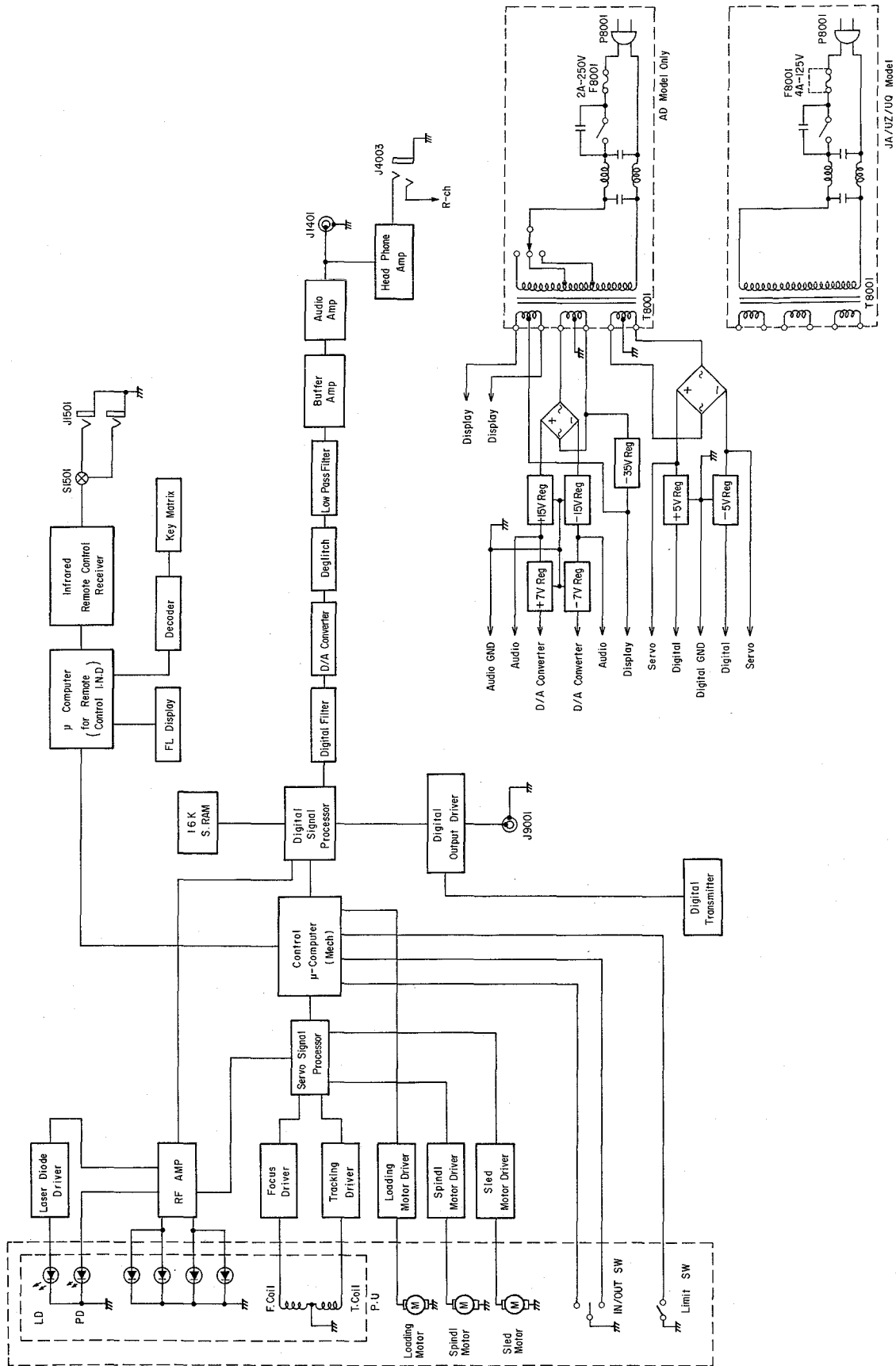

Parts Layout on P.C. Boards and Wiring Diagram (1/2) JA, AD and UZ model only

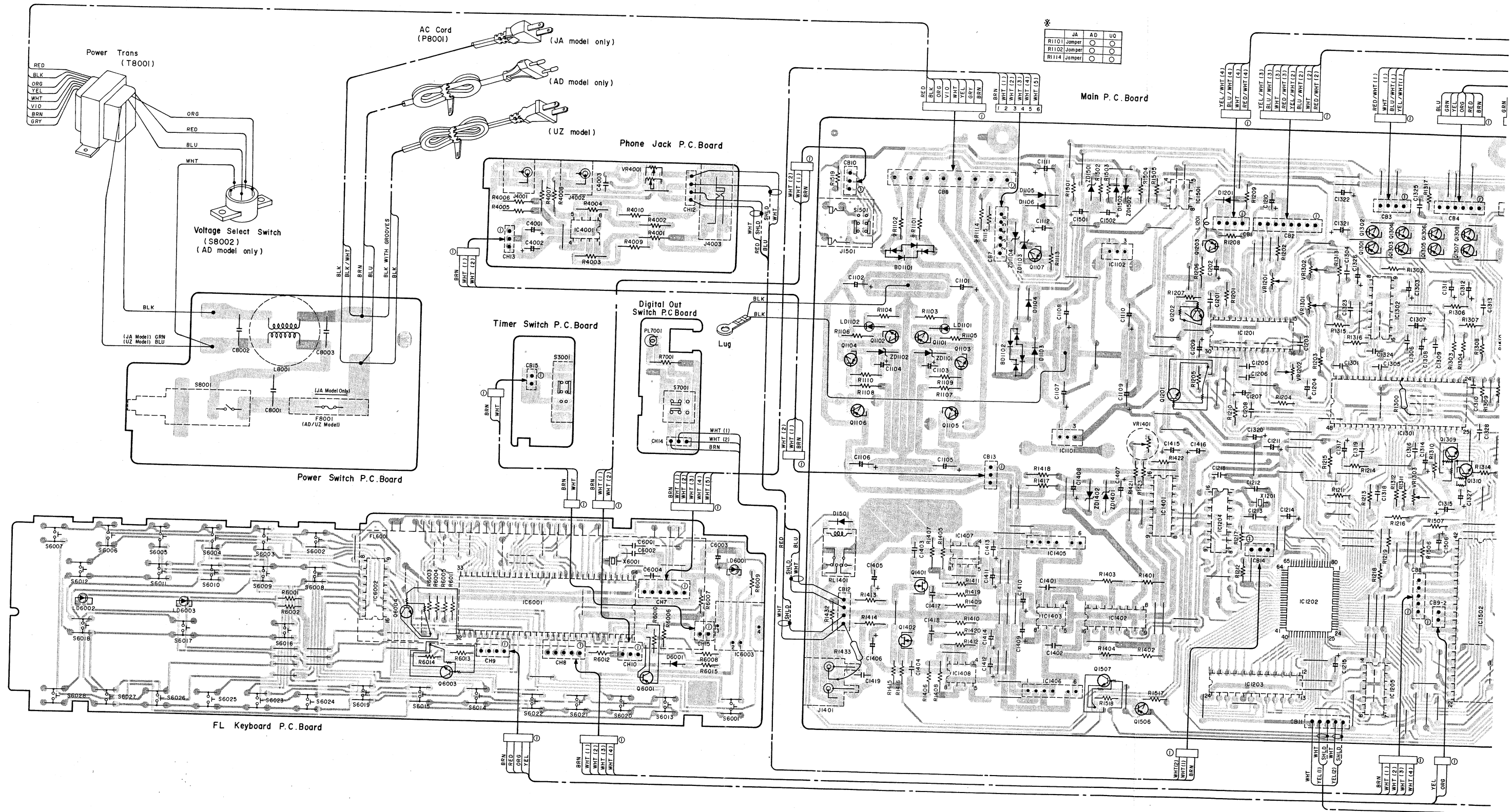

1/2) JA, AD and UZ model only

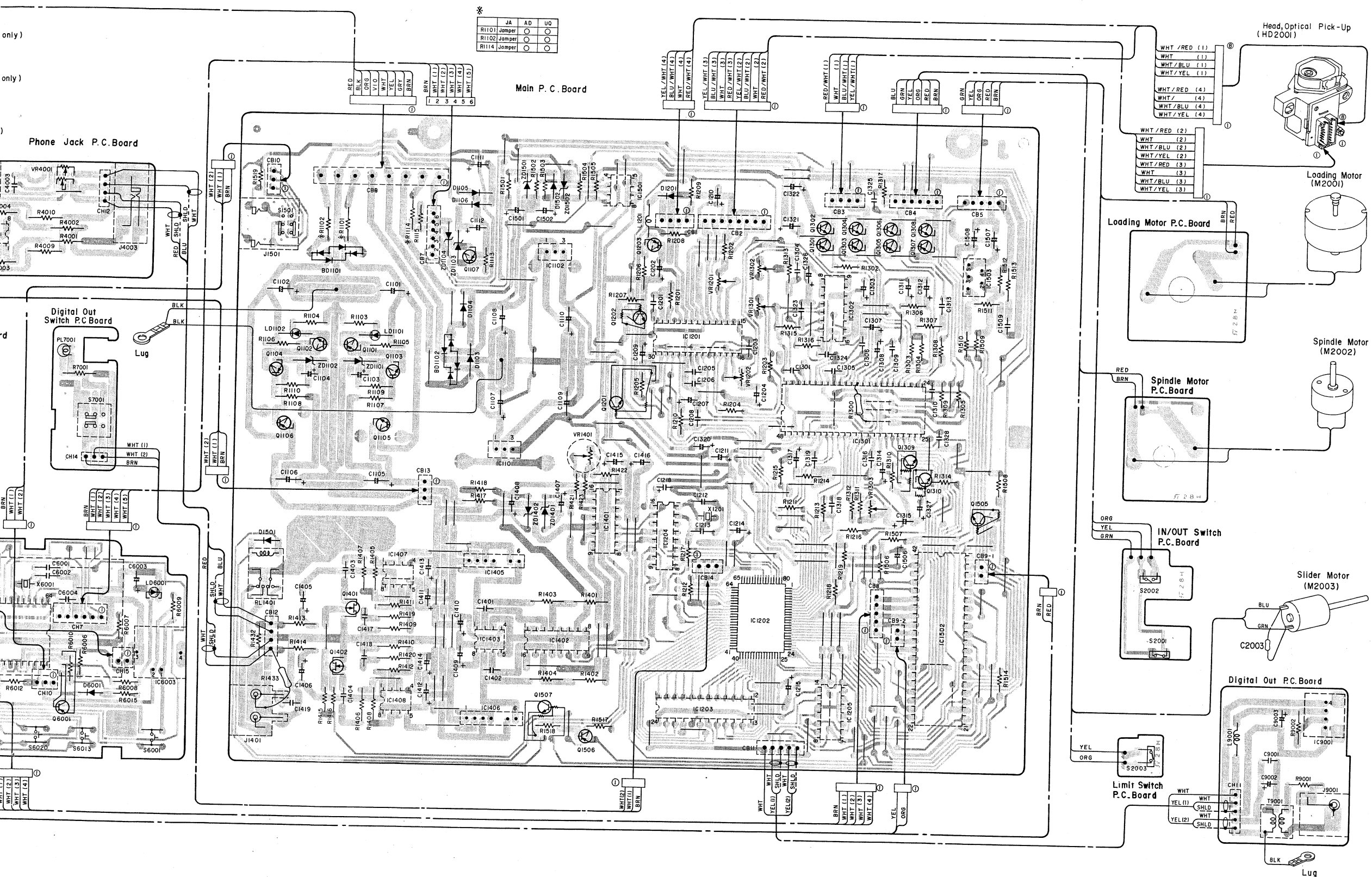

	JA	AD	UZ
R1101 Jumper	○	○	○
R1102 Jumper	○	○	○
R1114 Jumper	○	○	○

- BLU Blue
- GRN Green
- BLK Black
- GRY Gray
- WHT White
- RED Red
- BRN Brown
- ORG Orange
- YEL Yellow
- VIO Violet
- PNK Pink
- GRN/WHT Green/White
- GRY/WHT Gray/White
- GRY/YEL Gray/Yellow
- GRN/YEL Green/Yellow
- SHLD Shield

Parts Layout on P.C. Boards and Wiring Diagram (2/2) UQ model only

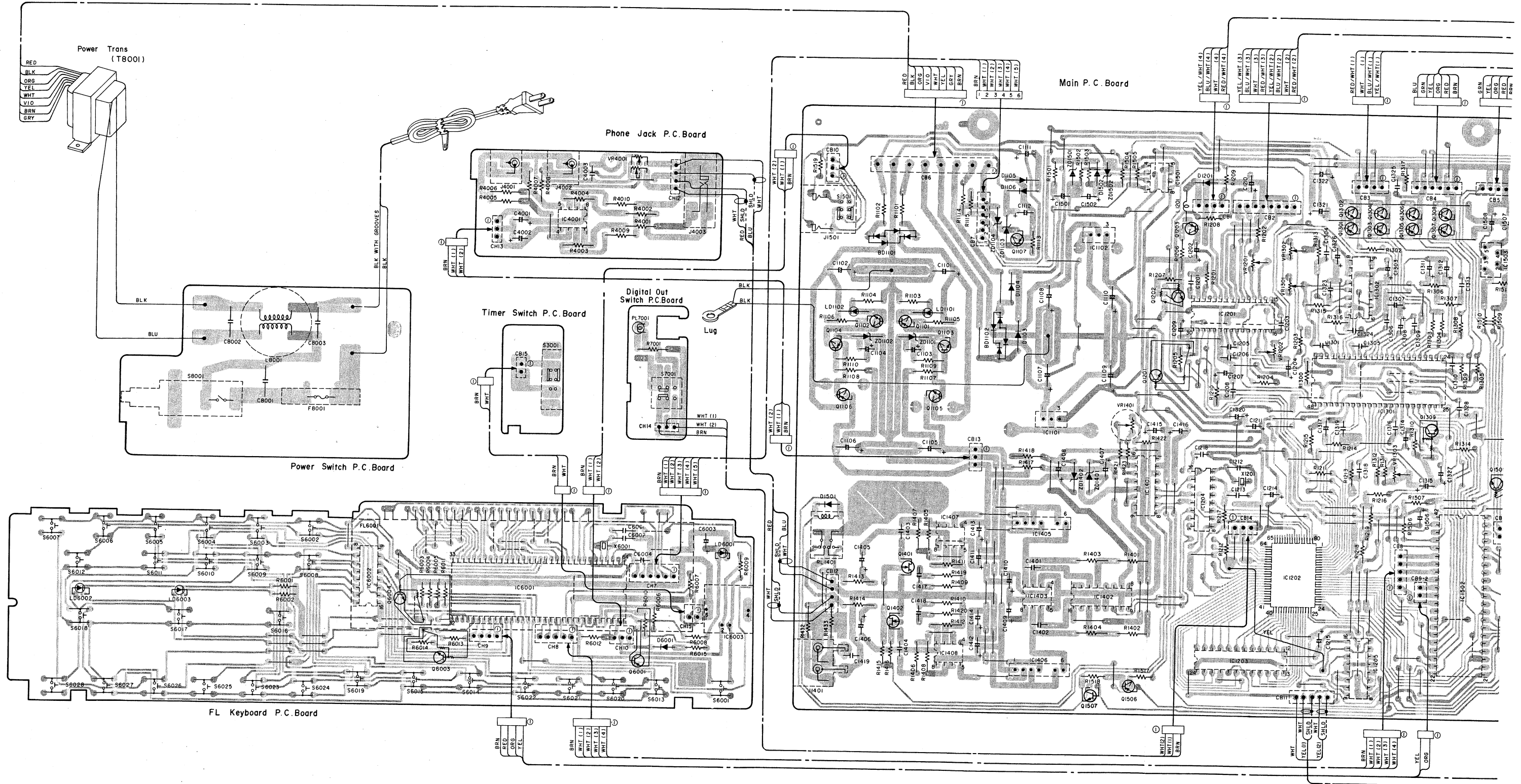

(2/2) UQ model only

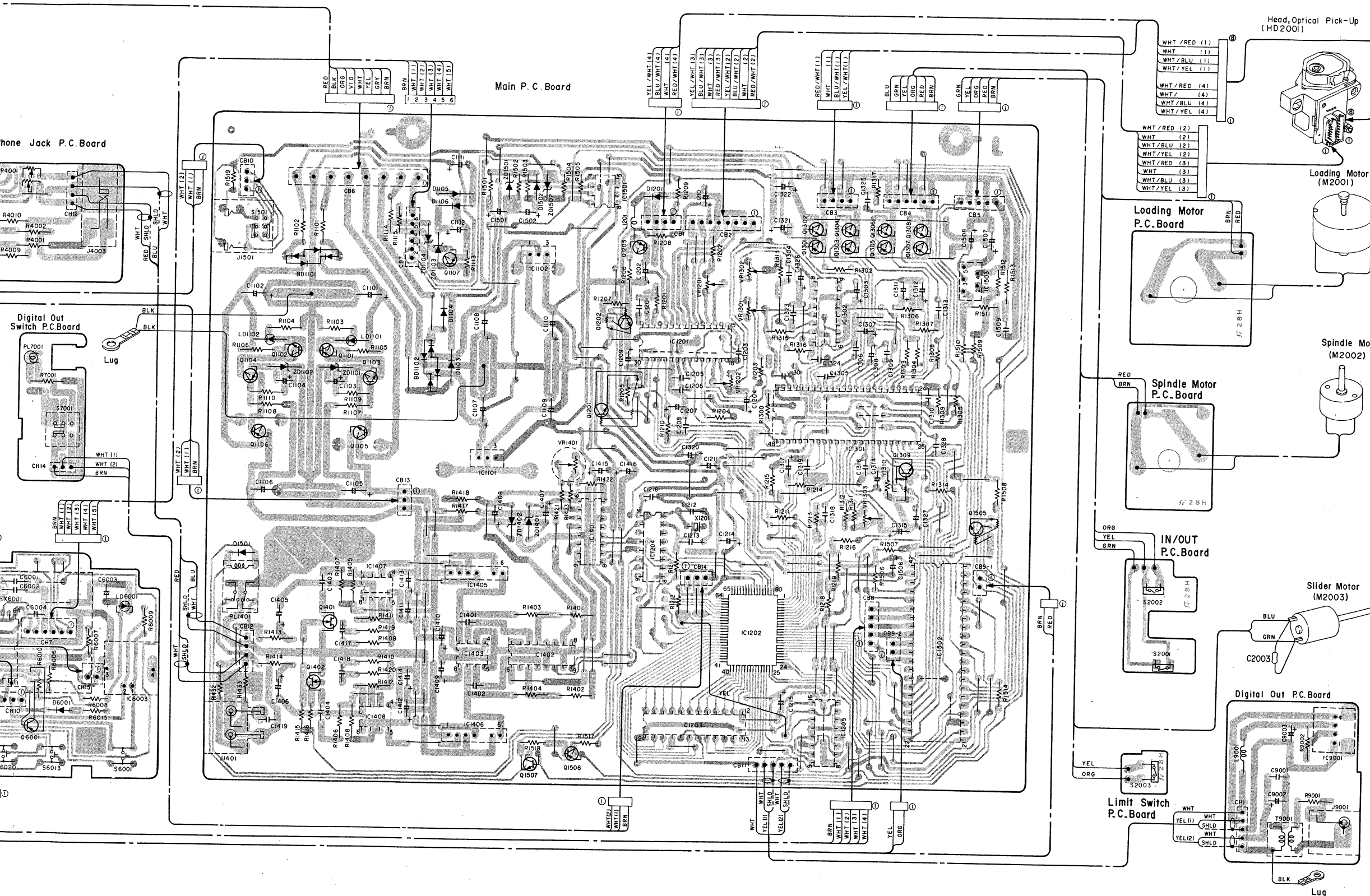

- BLU Blue
- GRN Green
- BLK Black
- GRY Gray
- WHT White
- RED Red
- BRN Brown
- ORG Orange
- YEL Yellow
- VIO Violet
- PNK Pink
- GRN/WHT Green/White
- GRY/WHT Gray/White
- GRY/YEL Gray/Yellow
- GRN/YEL Green/Yellow
- SHLD Shield

Schematic Diagram (1/2)

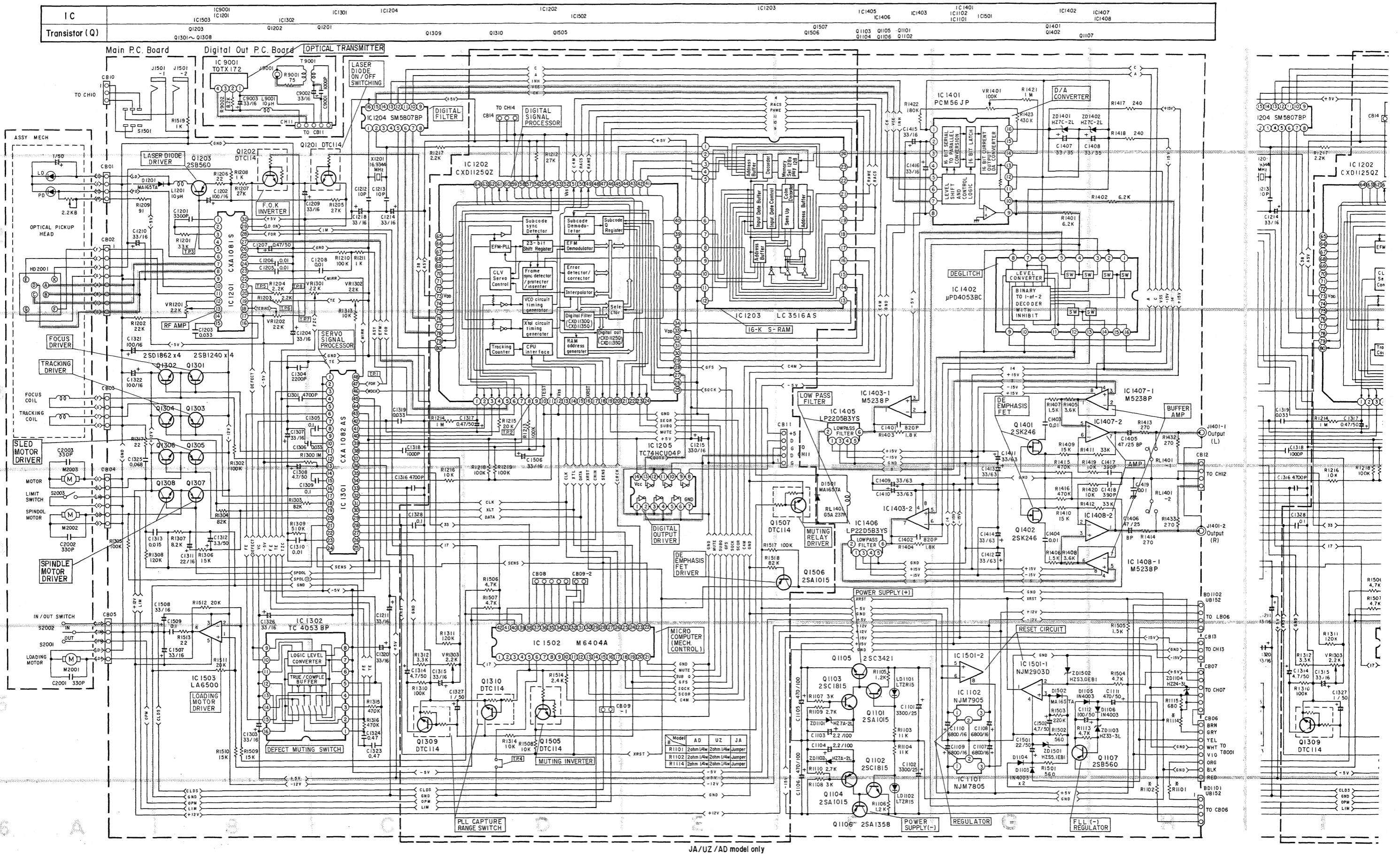

JA/UZ/AD model only

Schematic Diagram (2/2)

IC	IC6001	IC6002
Transistor(Q)	Q6001	Q6003 Q6004

FL Keyboard P.C. Board

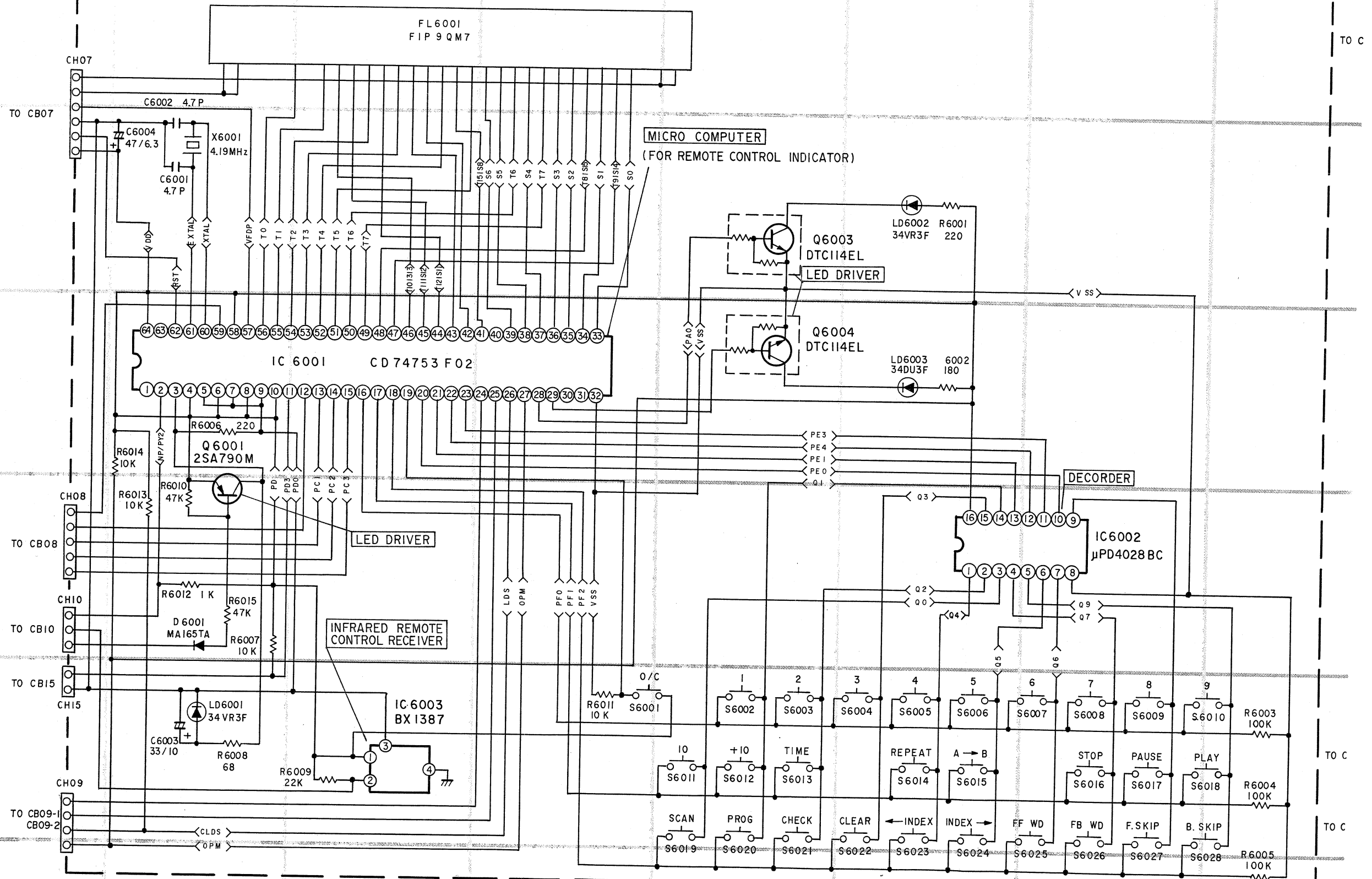

D-117

IC 6002

IC 4001

NOTES:

- All resistance values are in ohms. K = 1,000
- All capacitance values are in microfarads. P = $\frac{1}{1,000,000}$

03
04

Digital Out Switch P.C. Board

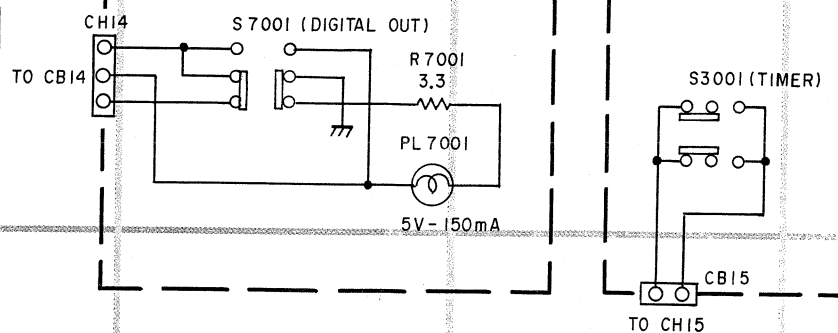

Power Switch P.C. Board (JA/UQ Model only)

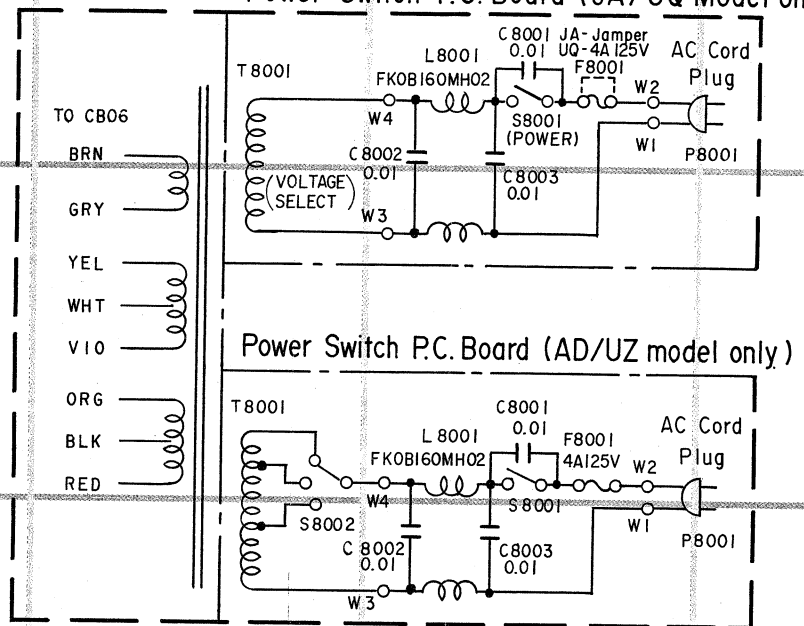

Power Switch P.C. Board (AD/UZ model only)

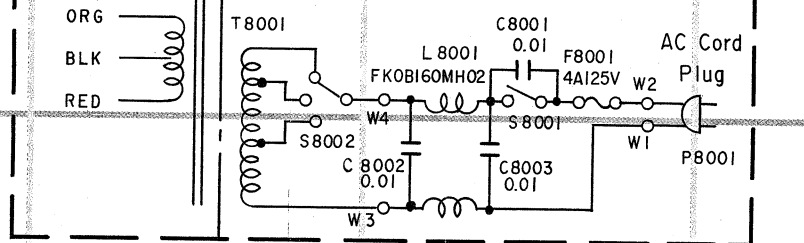

Phone P.C. Board

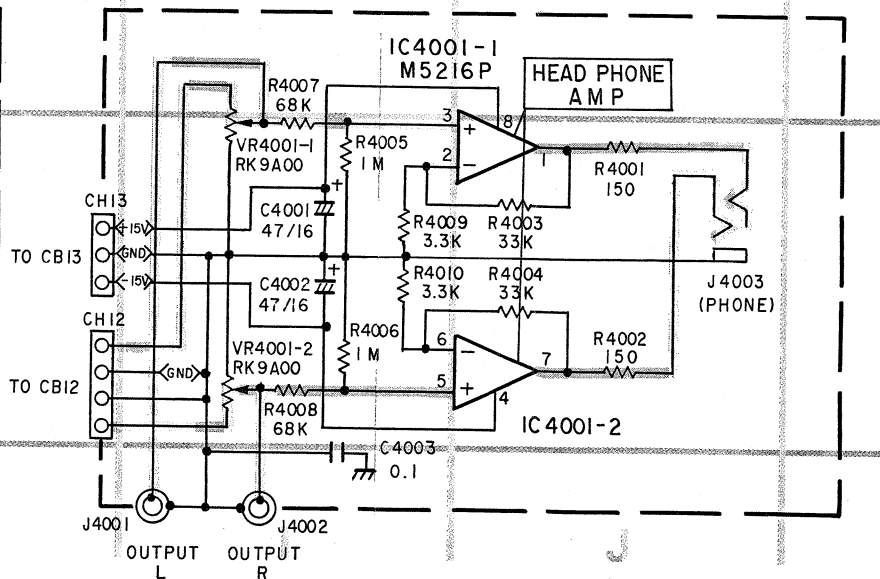

	B	C	E
Q6003	5V	0V	0V
Q6004	0V	3.7V	0V
Q6001	5V	0V	5V

IC 6001

1	-	33	-3.4~5V
2	5V	34	-3.4~5V
3	0V	35	-3.4~5V
4	5V	36	-3.4~5V
5	0V	37	-3.4~5V
6	0V	38	-3.4~5V
7	0V	39	-3.4~5V
8	5V	40	-
9	0V	41	-3.4V~5V
10	5V	42	-3.4~5V
11	5V	43	-3.4V~5V
12	0V	44	-3.4V~5V
13	5V	45	-3.4V~5V
14	5V	46	-3.4V~5V
15	5V	47	-3.4V~5V
16	0V	48	-3.4V~5V
17	0V	49	-3.4V~5V
18	0V	50	-3.4V~5V
19	0V	51	-3.4V~5V
20	0V	52	-3.4V~5V
21	0V	53	-3.4V~5V
22	0V	54	-3.4V~5V
23	0V	55	-3.4V~5V
24	5V	56	-3.4V~5V
25	5V	57	0V
26	5V	58	5V
27	0V	59	5V
28	5V	60	2.2V
29	0V	61	0V
30	-	62	5V
31	-	63	-
32	0V	64	5V

IC 4001

1	0V
2	0V
3	0V
4	-15V
5	0V
6	0V
7	0V
8	+15V

IC 6002

1	0V	9	0V
2	0V	10	0V
3	5V	11	0V
4	0V	12	0V
5	0V	13	0V
6	0V	14	0V
7	0V	15	0V
8	0V	16	5V

R

CONTROL INDICATOR)

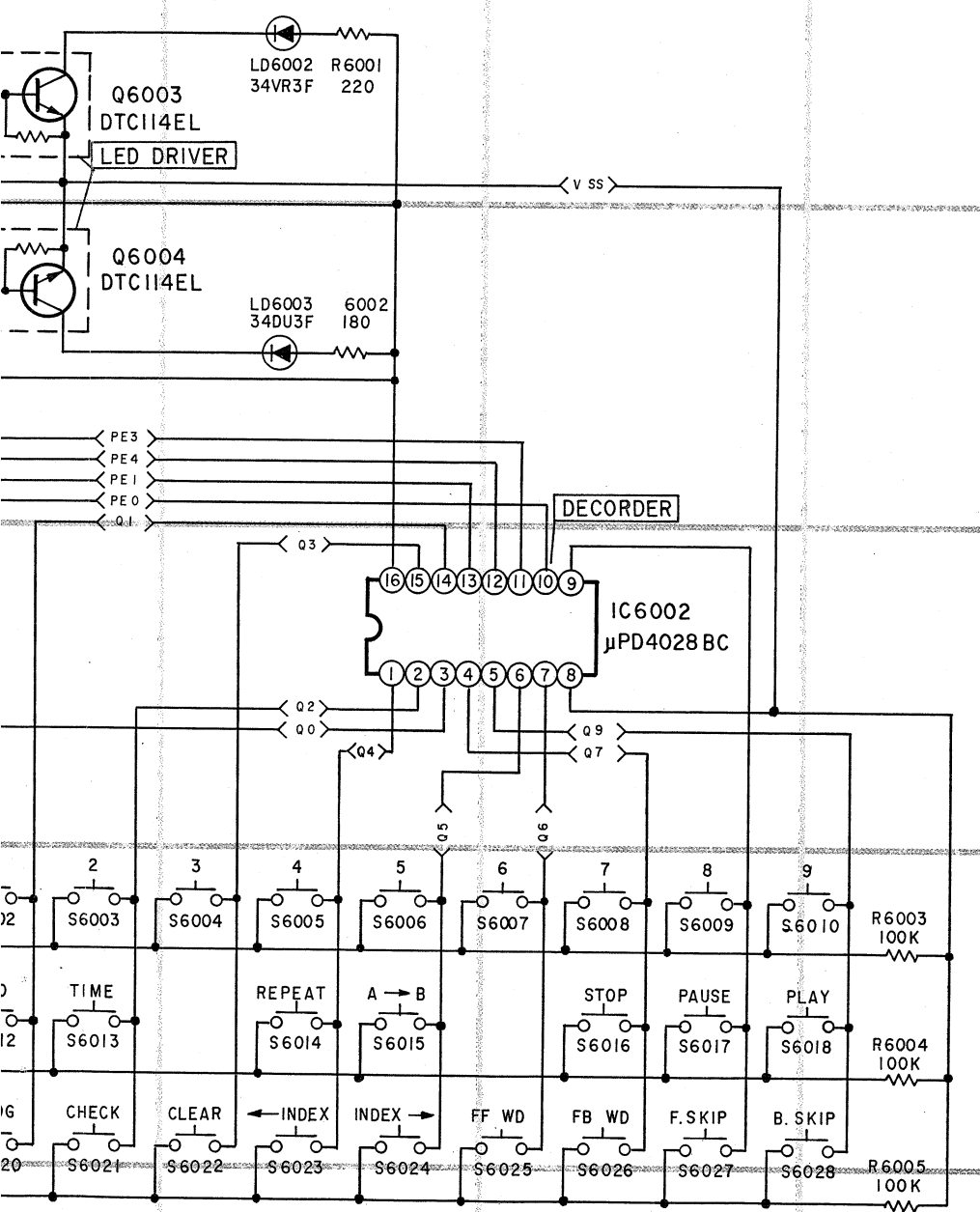

Electrical Parts List

Resistor : Carbon resistors under 1/4 watts are not mentioned in the parts list, please confirm them by schematic diagram.
 uF = microfarads, pF = picofarads

Abbreviations			
RES. = Resistor	CAP. = Capacitor		
C.F. = Carbon Film	ELY. = Electrolytic		
M.F. = Metal Film	CER. = Ceramic		
M.O. = Metal Oxide Film	MYL. = Mylar		
M.P. = Metal Plate	TAN. = Tantalum		
TR. = Transistor	POLY. = Polystyrol		
TRANS. = Transformer	PP. = Polypropylene		
CP. = Chip	PLT. = Polyethylene		

Symbol No.	Part No.	Description		
Main P. C. Board				
IC's				
IC1101	51T80338F01	NJM7805		
IC1102	51T80339F01	NJM7905		
IC1201	51T84721F01	CXA1081S		
IC1202	51T84720F01	CXD1125QZ		
IC1203	51T84723F01	LC3516AS		
IC1204	51T84724F02	SM5807BP		
● IC1205	51T80475F01	TC74HCU04P		
■ IC1205	51T80475F01	TC74HCU04P		
▲ IC1205	51T80475F01	TC74HCU04P		
★ IC1205	51T93405F01	HD74HC366P		
IC1301	51T84722F01	CXA1082AS		
IC1302	51T68388F01	TC4053BP		
IC1401	51T80318F01	PCM56JP		
IC1402	51T67480F01	μ PD4053BC		
IC1403	51T80136F01	M5238P		
IC1405	51T92601F01	LP22D5B3YS		
IC1406	51T92601F01	LP22D5B3YS		
IC1407	51T80136F01	M5238P		
IC1408	51T80136F01	M5238P		
IC1501	51T64227F01	NJM2903D		
IC1502	51T84725F01	M640AA		
IC1503	51T91028F01	LA6500		
Transistors				
Q1101	48T51118F02	2SA1015		
Q1102	48S43525F03	2SC1815		
Q1103	48S43525F03	2SC1815		
Q1104	48T51118F02	2SA1015		
Q1105	48T69176F02	2SC3421		
Q1106	48T69177F02	2SA1358		
Q1107	48T58775F02	2SB560		
Q1201	48T62965F02	DTC114		
Q1202	48T62965F02	DTC114		
Q1203	48T58775F02	2SB560		

Symbol No.	Part No.	Description		
Q1301	48T84238F04	2SB1240		
Q1302	48T83834F04	2SD1862		
Q1303	48T84238F04	2SB1240		
Q1304	48T83834F04	2SD1862		
Q1305	48T84238F04	2SB1240		
Q1306	48T83834F04	2SD1862		
Q1307	48T84238F04	2SB1240		
Q1308	48T83834F04	2SD1862		
Q1309	48T62965F02	DTC114		
● Q1310	48T62965F02	DTC114		
■ Q1310	48T62965F02	DTC114		
▲ Q1310	48T62965F02	DTC114		
Q1401	48T66948F01	FET, 2SK246		
Q1402	48T66948F01	FET, 2SK246		
Q1505	48T62965F02	DTC114		
Q1506	48T51118F02	2SA1015		
● Q1507	48T62965F02	DTC114		
■ Q1507	48T62965F02	DTC114		
▲ Q1507	48T62965F02	DTC114		
★ Q1507	48T57305F04	2SD1302		
Diodes/LEDs				
D1103	48S40477U01	IN4003		
D1104	48S40477U01	IN4003		
D1105	48S40477U01	IN4003		
D1106	48S40477U01	IN4003		
D1201	48T44813F01	MA165TA		
D1501	48T44813F01	MA165TA		
D1502	48T44813F01	MA165TA		
● LD1101	48T60971F01	LED, LTZ-R15 (RED)		
■ LD1101	48T60971F01	LED, LTZ-R15 (RED)		
▲ LD1101	48T60971F01	LED, LTZ-R15 (RED)		
★ LD1101	48T52953F03	LED, BR5507S (RED)		
● LD1102	48T60971F01	LED, LTZ-R15 (RED)		
■ LD1102	48T60971F01	LED, LTZ-R15 (RED)		
▲ LD1102	48T60971F01	LED, LTZ-R15 (RED)		
★ LD1102	48T52953F03	LED, BR5507S (RED)		
ZD1101	48T52741F11	Zener, HZ7A-2L		
ZD1102	48T52741F11	Zener, HZ7A-2L		
ZD1103	48T52741F72	Zener, HZ33-3L		
ZD1104	48T52741F63	Zener, HZ24-3L		
ZD1401	48T52741F17	Zener, HZ7C-2L		
ZD1402	48T52741F17	Zener, HZ7C-2L		
ZD1501	48T68697F17	Zener, HZS5. 1EB1		
ZD1502	48T68697F03	Zener, HZS3. 0EB1		
● BD1101	48T62282F01	Bridge UB152		
■ BD1101	48T62282F01	Bridge UB152		

Notes : ● : Japanese model only (JA), ■ : West Germany model only (AD), ▲ : North American model only (UZ), ★ : Canadian model only (UQ), Others : Common.

Symbol No.	Part No.	Description			Symbol No.	Part No.	Description		
▲	BD1101	48T62282F01	Bridge UB152			C1204	23T00138L19	ELY., 33 μ F/16V	
★	BD1101	48T62282F01	Bridge UB152F			C1205	08T00015L25	PP., 0.01 μ F	
●	BD1102	48T62282F02	Bridge UB152			C1206	08T00015L25	PP., 0.01 μ F	
■	BD1102	48T62282F01	Bridge UB152			C1207	23T00138L44	ELY., 0.47 μ F/50V	
▲	BD1102	48T62282F01	Bridge UB152			C1208	08T00015L25	PP., 0.01 μ F	
★	BD1102	48T62282F02	Bridge UB152F						
Coil									
L1201	24T50508F22	Inductor 10 μ H				C1209	23T00138L19	ELY., 33 μ F/16V	
Relay/Crystal									
RL1401	80T68404F02	Relay, G5A 237P-5V				C1210	23T00138L19	ELY., 33 μ F/16V	
X1201	48T84727F01	Crystal, 16.9344MHz				C1211	23T00138L19	ELY., 33 μ F/16V	
Jacks									
J1401	09T84616F02	Plate, Phono (OUTPUT L/R)				C1212	08T55260F13	CER., 10pF	
J1501 S1501	09T84124F01	Jack, Head Phone (SERIAL REMOTE IN /OUT)				C1213	08T55260F13	CER., 10pF	
Capacitors									
C1101	23T90770F51	ELY., 3300 μ F/25V				C1214	23T00138L19	ELY., 33 μ F/16V	
C1102	23T90770F51	ELY., 3300 μ F/25V			●	C1215	23T00134L34	ELY., 330 μ F/16V	
C1103	23T90770F98	ELY., 2.2 μ F/100V			■	C1215	23T00134L34	ELY., 330 μ F/16V	
C1104	23T90770F98	ELY., 2.2 μ F/100V			▲	C1215	23T00134L34	ELY., 330 μ F/16V	
C1105	23T90771F09	ELY., 470 μ F/100V			★	C1215	23T00134L36	ELY., 1000 μ F/16V	
C1106	23T90771F09	ELY., 470 μ F/100V				C1218	23T00138L19	ELY., 33 μ F/16V	
C1107	23T00160L39	ELY., 6800 μ F/16V				C1301	08T00015L21	PP., 4700pF	
C1108	23T00160L39	ELY., 6800 μ F/16V				C1303	23T00138L19	ELY., 33 μ F/16V	
C1109	23T00160L39	ELY., 6800 μ F/16V				C1304	08T00015L17	PP., 2200pF	
C1110	23T00160L39	ELY., 6800 μ F/16V				C1305	08T00015L37	PP., 0.1 μ F	
C1111	23T00134L74	ELY., 470 μ F/50V				C1306	08T00015L31	PP., 0.033 μ F	
C1112	23T00138L53	ELY., 100 μ F/50V				C1307	23T00138L19	ELY., 33 μ F/16V	
C1201	08T00015L19	PP., 3300pF				C1308	23T00138L48	ELY., 4.7 μ F/50V	
C1202	23T00138L21	ELY., 100 μ F/16V				C1309	08T00015L37	PP., 0.1 μ F	
C1203	08T00015L31	PP., 0.033 μ F				C1310	08T00015L25	PP., 0.01 μ F	
						C1311	23T00138L18	ELY., 22 μ F/16V	
						C1312	23T00138L47	ELY., 3.3 μ F/50V	
						C1313	08T00015L27	PP., 0.015 μ F	
						C1314	23T00138L48	ELY., 4.7 μ F/50V	
						C1315	23T00138L19	ELY., 33 μ F/16V	
						C1316	08T00015L21	PP., 4700pF	
						C1317	23T00138L44	ELY., 0.47 μ F/50V	
						C1318	08T00015L13	PP., 1000pF	
						C1319	08T00015L31	PP., 0.033 μ F	
						C1320	23T00138L19	ELY., 33 μ F/16V	
						C1321	23T00134L32	ELY., 100 μ F/16V	
						C1322	23T00134L32	ELY., 100 μ F/16V	
						C1323	08T57851F21	TF., 0.47 μ F	
						C1324	08T57851F21	TF., 0.47 μ F	
					●	C1325	08T90316F27	TF., 0.068 μ F	
					■	C1325	08T90316F27	TF., 0.068 μ F	
					▲	C1325	08T90316F27	TF., 0.068 μ F	
					★	C1325	08T57851F11	TF., 0.068 μ F	
						C1326	23T00138L19	ELY., 33 μ F/16V	
					●	C1327	23T00138L45	ELY., 1 μ F/50V	
					■	C1327	23T00138L45	ELY., 1 μ F/50V	
					▲	C1327	23T00138L45	ELY., 1 μ F/50V	
					★	C1327	23T00136L60	ELY., 1 μ F/50V	
						C1328	08T57298F01	CER., 0.1 μ F	
						C1401	08T93192F47	PS, 820pF	

Notes : ● : Japanese model only (JA), ■ : West Germany model only (AD), ▲ : North American model only (UZ),
★ : Canadian model only (UQ), Others : Common.

Symbol No.	Part No.	Description			Symbol No.	Part No.	Description		
C1402	08T93192F47	PS, 820pF			VR1202	18B44064J10	SOL.		
C1403	08T00151L25	PP., 0.01 μ F					22K ohm 1/2W		
C1404	08T00151L25	PP., 0.01 μ F			VR1301	18B44064J10	SOL.		
C1405	23T81030F36	ELY., 47 μ F/25V					22K ohm 1/2W		
		(B.P.)			VR1302	18B44064J10	SOL.		
C1406	23T81030F36	ELY., 47 μ F/25V					22K ohm 1/2W		
		(B.P.)			VR1303	18B44064J08	SOL.		
C1407	23T00138L38	ELY., 33 μ F/35V					2.2K ohm 1/2W		
C1408	23T00138L38	ELY., 33 μ F/35V			VR1401	18B44064J07	SOL.		
C1409	23T00138L61	ELY., 33 μ F/63V					100K ohm 1/2W		
C1410	23T00138L61	ELY., 33 μ F/63V			PHONE P. C. Board				
C1411	23T00138L61	ELY., 33 μ F/63V			IC				
C1412	23T00138L61	ELY., 33 μ F/63V			IC4001	51T81896F01	M5216P		
C1413	23T00138L61	ELY., 33 μ F/63V			Jacks				
C1414	23T00138L61	ELY., 33 μ F/63V			J4001	09T67396F01	Plate, Phone (OUTPUT L)		
C1415	23T00138L19	ELY., 33 μ F/16V			J4002	09T67396F01	Plate, Phone (OUTPUT R)		
C1416	23T00138L19	ELY., 33 μ F/16V			J4003	09T74077F01	Jack, Phones (PHONE)		
C1417	08T00151L08	PP., 390pF			Capacitors				
C1418	08T00151L08	PP., 390pF			C4001	23T00138L20	ELY., 47 μ F/16V		
C1419	08T00015L25	PP., 0.01 μ F			C4002	23T00138L20	ELY., 47 μ F/16V		
C1501	23T00138L50	ELY., 22 μ F/50V			C4003	08T57298F01	CER., 0.1 μ F		
C1502	23T00138L48	ELY., 4.7 μ F/50V			Resistors				
C1506	23T00138L19	ELY., 33 μ F/16V			■ R1101	06T66931F04	MF., 2 ohm 1/4W		
C1507	23T00138L19	ELY., 33 μ F/16V			▲ R1101	06T66931F04	MF., 2 ohm 1/4W		
C1508	23T00138L19	ELY., 33 μ F/16V			★ R1101	06T66931F04	MF., 2 ohm 1/4W		
● C1509	08T90316F29	TF., 0.1 μ F			■ R1102	06T66931F04	MF., 2 ohm 1/4W		
■ C1509	08T90316F29	TF., 0.1 μ F			▲ R1102	06T66931F04	MF., 2 ohm 1/4W		
▲ C1509	08T90316F29	TF., 0.1 μ F			★ R1102	06T66931F04	MF., 2 ohm 1/4W		
★ C1509	08T57851F13	TF., 0.1 μ F			■ R1114	06T66931F04	MF., 2 ohm 1/4W		
					▲ R1114	06T66931F04	MF., 2 ohm 1/4W		
					★ R1114	06T66931F04	MF., 2 ohm 1/4W		
					★ R1114	06T66931F04	MF., 2 ohm 1/4W		
					VR1201	18B44064J10	SOL.		
							22K ohm 1/2W		
					FL Keyboard P. C. Board				
					IC's				
					IC6001	51T74753F02	74753F02		
					IC6002	51T51507F01	μ PD4028BC		
					IC6003	51T84120F01	BX1387		
					Transistors				
					● Q6001	48T64382F01	2SA790M		
					■ Q6001	48T64382F01	2SA790M		
					▲ Q6001	48T64382F01	2SA790M		
					★ Q6001	48T64382F03	2SA790M		
					Q6003	48T82763F02	DTC114EL		
					Q6004	48T82763F02	DTC114EL		

Notes : ● : Japanese model only (JA), ■ : West Germany model only (AD), ▲ : North American model only (UZ), ★ : Canadian model only (UQ), Others : Common.

Symbol No.	Part No.	Description			Symbol No.	Part No.	Description		
Diode/LEDs					Crystal/Capacitors				
D6001	48T44813F01	MA165TA			X6001	91T60592F02	Crystal, Lock, 4.19MHz		
LD6001	48T60947F05	LED, SLH-34VR3F (RED)			C6001	08T55260F09	CER., 4.7pF		
LD6002	48T60947F05	LED, SLH-34VR3F (RED)			C6002	08T55260F09	CER., 4.7pF		
LD6003	48T60947F07	LED, SLH-34DU3F (ORG)			C6003	23S57422F12	ELY., 33 μ F/10V		
					C6004	23S57422F14	ELY., 47 μ F/6.3V		
Switches					Digital Out Switch P. C. Board				
S6001	40T83324F01	Tact SKHHAP (0/C)			Switch/Lamps				
S6002	40T83324F01	Tact SKHHAP (1)			S7001	40T65584F01	Switch, SPH 221H (DIGITAL OUT)		
S6003	40T83324F01	Tact SKHHAP (2)			● PL7001	65T80326F01	Pilot (5V-150mA)		
S6004	40T83324F01	Tact SKHHAP (3)			■ PL7001	65T80326F01	Pilot (5V-150mA)		
S6005	40T83324F01	Tact SKHHAP (4)			▲ PL7001	65T80326F01	Pilot (5V-150mA)		
S6006	40T83324F01	Tact SKHHAP (5)			★ PL7001	65T80326F02	Pilot (5V-150mV)		
S6007	40T83324F01	Tact SKHHAP (6)			Power Switch P. C. Board				
S6008	40T83324F01	Tact SKHHAP (7)			Lamp/Switch				
S6009	40T83324F01	Tact SKHHAP (8)			L8001	24T82315F01	Choke, Filter, FKOB160MH02		
S6010	40T83324F01	Tact SKHHAP (9)			S8001	40T84122F01	Switch, Power SDDLE (POWER)		
S6011	40T83324F01	Tact SKHHAP (10)			Capacitors				
S6012	40T83324F01	Tact SKHHAP (+10)			C8001	08T57437F09	CER., 0.01 μ F		
S6013	40T83324F01	Tact SKHHAP (TIME)			C8002	08T57437F09	CER., 0.01 μ F		
S6014	40T83324F01	Tact SKHHAP (REPEAT)			C8003	08T57437F09	CER., 0.01 μ F		
S6015	40T83324F01	Tact SKHHAP (A→B)			Digital Out P. C. Board				
S6016	40T83324F01	Tact SKHHAP (STOP)			IC/Inductor				
S6017	40T83324F01	Tact SKHHAP (PAUSE)			IC9001	51T84772F01	IC, TOTX172		
S6018	40T83324F01	Tact SKHHAP (PLAY)			L9001	24T50508F22	Inductor 10 μ H		
S6019	40T83324F01	Tact SKHHAP (SCAN)			Transformer/Jack				
S6020	40T83324F01	Tact SKHHAP (PROG)			T9001	25T90530F01	TRANS., PULS		
S6021	40T83324F01	Tact SKHHAP (CHECK)			J9001	09T84775F01	Plate, Phone Jack (DIGITAL OUT COAX)		
S6022	40T83324F01	Tact SKHHAP (CLEAR)							
S6023	40T83324F01	Tact SKHHAP (←INDEX)							
S6024	40T83324F01	Tact SKHHAP (INDEX→)							
S6025	40T83324F01	Tact SKHHAP (FF WD)							
S6026	40T83324F01	Tact SKHHAP (FB WD)							
S6027	40T83324F01	Tact SKHHAP (F.SKIP)							
S6028	40T83324F01	Tact SKHHAP (B.SKIP)							

Notes : ● : Japanese model only (JA), ■ : West Germany model only (AD), ▲ : North American model only (UZ), ★ : Canadian model only (UQ), Others : Common.

Symbol No.	Part No.	Description			Symbol No.	Part No.	Description		
Capacitors									
●	C9001	08T93192F49	PS,	1000pF					
■	C9001	08T93192F49	PS,	1000pF					
▲	C9001	08T93192F49	PS,	1000pF					
★	C9001	08T00015L13	PP.,	1000pF					
	C9002	23T00138L19	ELY.,	33 μ F/16V					
	C9003	23T00138L19	ELY.,	33 μ F/16V					
Miscellaneous									
	C2001	08S40154T43	CAP., CER.,	330pF					
	C2002	08S40154T43	CAP., CER.,	330pF					
	C2003	08S40154T43	CAP., CER.,	330pF					
■	F8001	65T42077U19	Fuse, Semko						
			(4A-125V)						
▲	F8001	65T66926F03	Fuse, Semko						
			(4A-125V)						
★	F8001	65T66926F03	Fuse, 51NM						
			(4A-125V)						
	FL6001	65T80320F01	FL, Display						
	HD2001	88T81528F01	Head, Optical Pick-up						
	M2001	01V81800F56	Assy., Motor Loading						
	M2002	59T81431F01	Motor, Spindle						
	M2003	59T81432F01	Motor, Slider						
■	P8001	28T43182P04	Plug, AC Cord						
▲	P8001	28T55335F02	Plug, AC Cord						
●	P8001	28T67434F04	Plug, AC Cord (12A)						
★	P8001	28T55335F02	Plug, AC Cord						
			SPT-2-P						
	VR4001	18T84123F01	Res., Volume, RK9A00						
	S2001	40T71025F01	Switch, Detector						
			(OUT)						
	S2002	40T71025F01	Switch, Detector (IN)						
	S2003	40T71025F01	Switch, Detector						
			(LIMIT)						
	S3001	40T84005F01	Switch, Slide SSSU1						
			(TIMER)						
■	S8002	40T80258F02	Switch, Voltage Select						
●	T8001	25T84728F01	Trans., Power						
■	T8001	25T90690F01	Trans., Power						
▲	T8001	25T90692F01	Trans., Power						
★	T8001	25T90692F01	Trans., Power						

Notes : ● : Japanese model only (JA), ■ : West Germany model only (AD), ▲ : North American model only (UZ), ★ : Canadian model only (UQ), Others : Common.

Cabinet Assembly Parts List

NOTE: The parts without part numbers are not supplied.

Symbol No.	Index	Part No.	Description	Symbol No.	Index	Part No.	Description		
▲	1	4-A	64D83886F05	Panel, Front	38	5-G	07A91046F01	Support, P.C.B.	
■	1	4-A	64D83886F05	Panel, Front	39		03S82672F18	Screw, Bind (M3 × 6)	
●	1	4-A	64D83886F06	Panel, Front	40		03S40012G98	Screw, Tapping (M3 × 8)	
★	1	4-A	64D83886F05	Panel, Front	41		03S40018G08	Screw, Tapping (M3 × 8)	
	2	4-B	07C91020F01	Assy., Front Frame	42	4-D	47A83883F01	Shaft, Power	
	3	1-C	15C83872F02	Cover, Top	43	4-D	43A83885F01	Spacer, Rubber	
	5	2-A	07D83863F04	Frame, Front	46	2-E	03S40012G48	Screw, Tapping (M3 × 6)	
	6		03S71031F04	Screw, Bind (M3 × 8)	47	1-D	03A83946F01	Screw, Special (M3 × 35)	
	7		03S71031F02	Screw, Bind (M2.6 × 8)	48	2-D	04S40071G14	Washer Spring Lock (M4.1)	
	8	3-B	36B83866F01	Knob, Eject	49	2-D	04S40070G59	Washer Flat (M4.1)	
	9	4-C	36B83865F02	Knob, Logic	50	2-A	02S40000G39	Nut, Hex (M7)	
	10	3-C	36B83864F02	Knob, Ten Key	51	3-E	01T84733F11	Assy., Lug Wire	
	11	4-B	36A83868F01	Knob, Tact (L)	56	2-E	03S40018G06	Screw, Tapping (M3 × 16)	
	12	4-B	36A83867F01	Knob, Tact (S)	57	4-D	14S81481F56	Insulator, Cover	
	13	2-A	36A80166F01	Knob, Timer Switch	58	2-A	14S81481F71	Insulator, Cover	
	14	3-D	01V84500F25	Assy., FL/ Keyboard P.C.B.	59	1-D	14S81481F72	Insulator, Cover	
	15	3-C	07A83876F01	Support, FL	60	4-E	75S92415F12	Cushion, Rubber	
	16	3-C	14S81481F57	Insulator, Cover	62	3-B	43A80198F01	Bush, Lamp	
	17	3-C	43A53357F04	Spacer, LED	63	3-F	07A84472F01	Fram Optical Output Jack	
	18	2-B	43A53357F01	Spacer, LED (A)	64		75A67064F01	Felt	
	19	3-H	03S82672F20	Screw, Bind (M3 × 8)	●	64	75A67064F01	Felt	
	21	2-H	16T82537F01	Cap, Pin Jack	▲	64	75A67064F01	Felt	
	23	3-D	43T53136F01	Bush, Cap	★	64	75A94848F01	Pad, Felt	
	24	5-B	07A84422F01	Bracket, Panel	65	5-A	36A83871F01	Knob, Push (Digital)	
	26		03S43997P76	Screw, Bind (M3 × 6)	66	1-D	14S81482F59	Insulator, Cover	
■	28	2-F	15C83873F07	Cover, Rear	67	5-C	14S53017F64	Insulator, Cover	
●	28	2-F	15C83873F08	Cover, Rear	68	3-E	01T84733F12	Assy., Lug Wire	
▲	28	2-F	15C83873F09	Cover, Rear	▲	69	09T51410F01	Holder, Fuse (SEMKO)	
★	28	2-F	15C83873F13	Cover, Rear	■	69	09T51410F01	Holder, Fuse (SEMKO)	
	29	2-E	03S44205G30	Screw, Pan (M2.6 × 4)	★	69	09T93096F01	Holder, Fuse	
	30	2-G	43B41625J02	Support, Cord	■	70	54B62266F16	Label, Fuse (4A-125V)	
	32		03S40036U01	Screw, Pan (M4 × 8)	★	70	3-E	14S81481F93	Insulator, Cover
	33		01A80230F01	Assy., Trannleg	★	71	04S40075G19	Washer, Polyslider (M4.1)	
	34		03S44205G20	Screw, Pan (M4 × 12)	★	72	01T92973F01	Assy., Lug Wire (1P)	
●	35		64B83869F02	Panel, Tray					
▲	35	2-C	64B83869F04	Panel, Tray					
■	35	2-C	64B83869F04	Panel, Tray					
★	35	2-C	64B83869F04	Panel, Tray					
	36	5-A	36A55234F04	Knob, Control					
	37	5-A	36A83870F01	Knob, Power					

Notes: ●: Japanese model only (JA), ■: West Germany model only (AD), ▲: North American model only (UZ), ★: Canadian model only (UQ), Others: Common.

Exploded View (Cabinet)

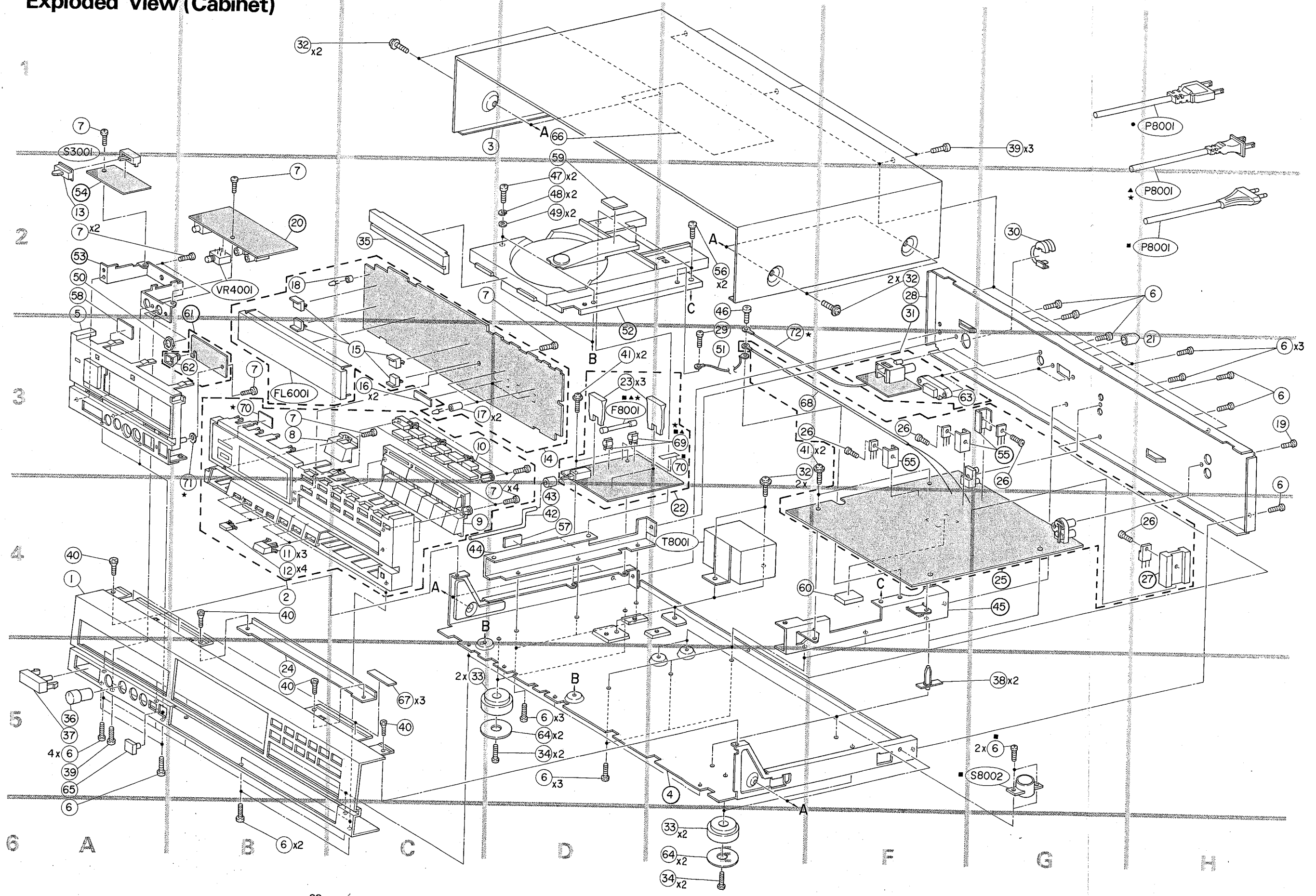

Exploded View (CD Mechanism)

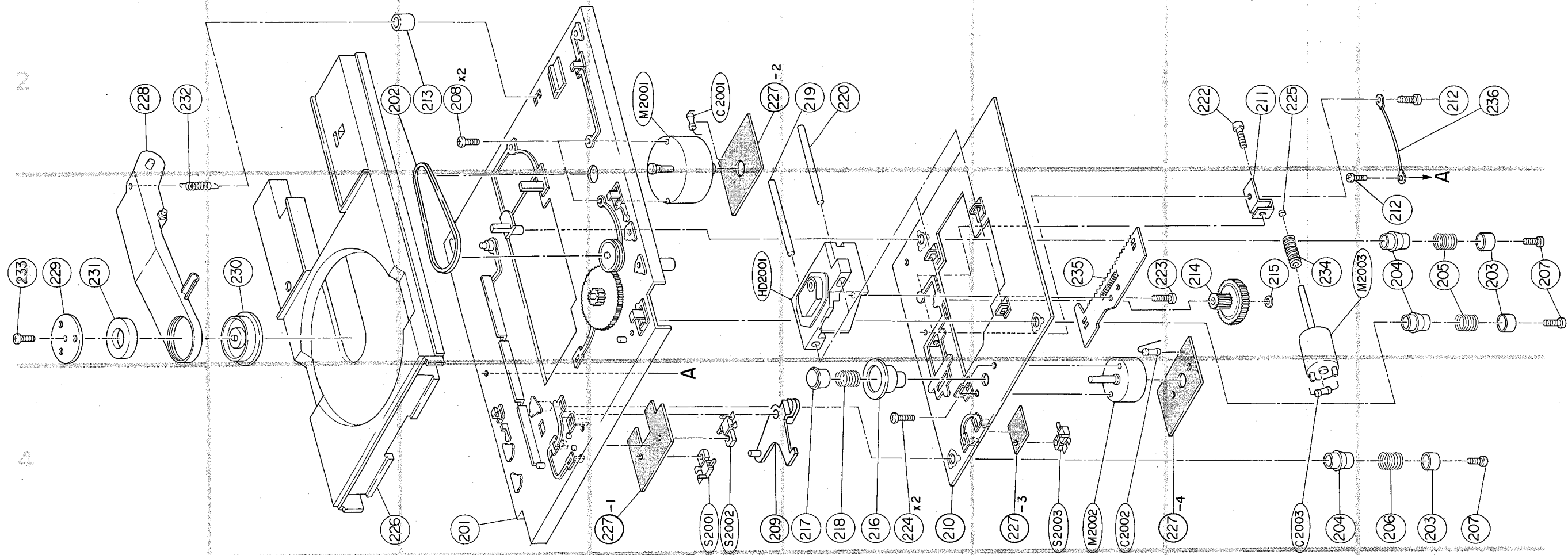

CD Mechanism Assembly Parts List

Symbol No.	Index	Part No.	Description			Symbol No.	Index	Part No.	Description		
201	4-C	01B82391F01	Assy., Main Chassis								
202	2-C	42A81427F01	Belt, Drive								
203		43A81407F01	Bush, Damper								
204		75A81411F01	Rubber, Damper								
205	3-H	41A81428F03	Spring, Compression								
206	4-H	41A81428F05	Spring, Compression								
207		03S40012G18	Screw, Tapping (M2.6 × 6)								
208	2-C	03D40014G19	Screw, W/Washer (M2.6 × 5)								
209	4-E	45A81434F01	Arm, Switch								
211	2-G	07A82322F01	Bracket, Washer								
212		03S44205G30	Screw, Pan (M2.6 × 4)								
213	2-C	37S40133J16	Tube UL (20mm)								
214	3-G	44A81401F01	Gear, Worm Wheel								
215	3-G	04A41345P02	Washer, Lock (M1.7)								
216	4-E	49B81414F01	Table, Disc								
217	4-E	49B81417F01	Disc, Guide								
218	4-E	41A81428F01	Spring, Compression								
219	2-E	47A81426F01	Shaft, Head								
220	2-E	47A81426F02	Shaft, Head								
221		04S40075G12	Washer, Polyslider (M3.1)								
222	2-G	03D40014G61	Screw, W/Washer (M2 × 5)								
223	3-G	03S70494F01	Screw, Bind (M2 × 5)								
224	4-E	03D40014G07	Screw, W/Washer (M2 × 4)								
225	2-G	43A41182P02	Ball Steel								
226	4-B	01C81529F01	Assy., Tray Disc								
228	2-A	45C81418F01	Arm, Clamp								
229	3-A	07A81413F01	Bracket, Magnet								
230	3-B	49A81403F01	Wheel, Clamp								
231	3-A	59T81430F01	Magnet								
232	2-A	41B81429F02	Spring, Extension								
233	3-A	03S68555F17	Screw, Bind (M2 × 4)								
234	3-G	44A81424F01	Worm, Drive								
235	3-F	01A82323F01	Assy., Rack								
236	2-H	01T92483F01	Assy., Lug Wire 1P								

NOTE: The parts without part numbers are not supplied.

Packing Assembly Parts List

Symbol No.	Part No.	Description	Symbol No.	Part No.	Description	
■	101-1	68P81707F74 Owners Manual	101-5	60T58064F01	Battery, SUM-3	
▲	101-1	68P81707F75 Owners Manual	101-6	01T84773F01	Fiber, Tocc 172-150CB	
●	101-1	68P81707F80 Owners Manual	●	102	56S83833F10	Carton, Packing
★	101-1	68P81707F74 Owners Manual	■	102	56S83833F12	Carton, Packing
	101-2	28T70621F03 Plug, Output	▲	102	56S83833F12	Carton, Packing
	101-3	01T82091F01 Assy., Mini Plug Cord	★	102	56S83833F12	Carton, Packing
●	101-4	01T80478F01 Unit, Remocon (RD109 AL)	103	56D90648F01	Tray, Packing	
■	101-4	01T80478F02 Unit, Remocon (RD109 AD)	104	56D90649F01	Tray, Packing	
▲	101-4	01T80478F02 Unit, Remocon (RD109 LX)	105	56B40442T19	Packing, Front Frame	
★	101-4	01T80478F02 Unit Remocon (RD109 LX)	106	56B40230G23	Sack, Polyethylene	
			107	56B40230G08	Sack, Polyethylene	
			108	56A93246F01	Pad, Packing	

Notes : ● : Japanese model only (JA), ■ : West Germany model only (AD), ▲ : North American model only (UZ), ★ : Canadian model only (UQ), Others : Common.

Packing Method View

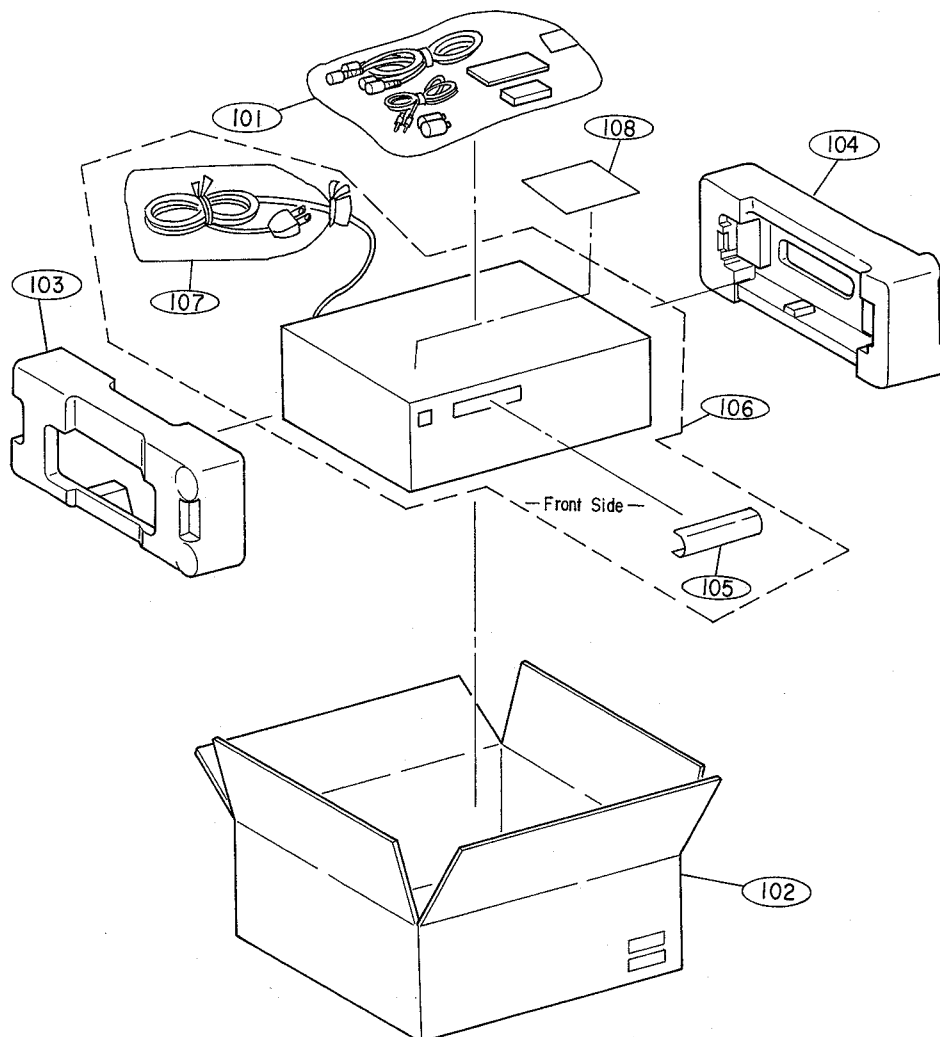

CXD1125QZ : IC1202

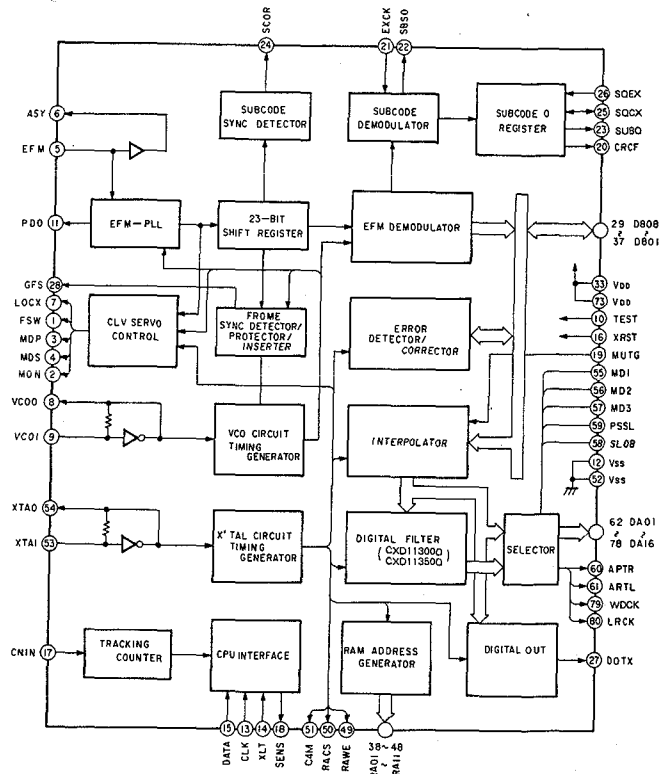
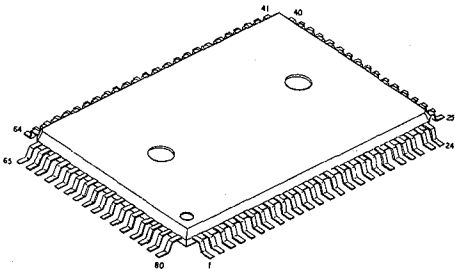

LC3516AS15 : IC1203

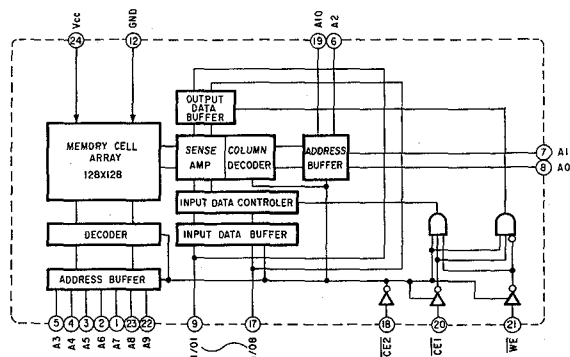
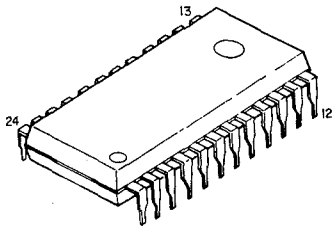

SM5807BP : IC1204

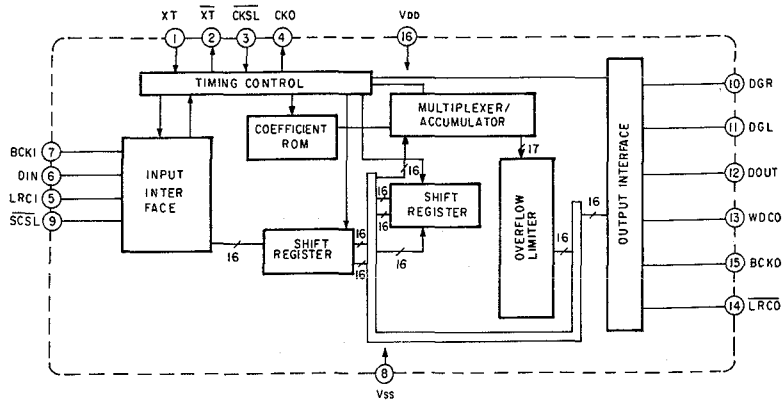
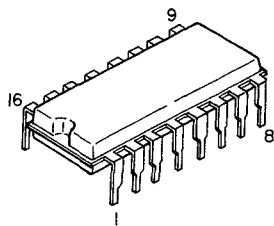

HD74HC366P : IC1205★

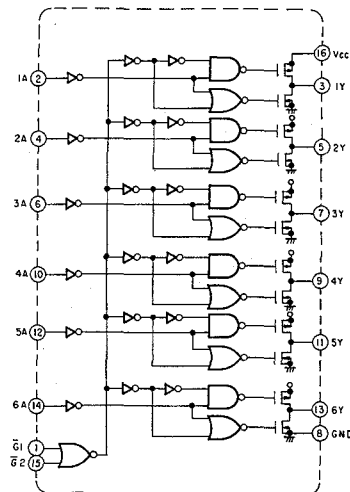
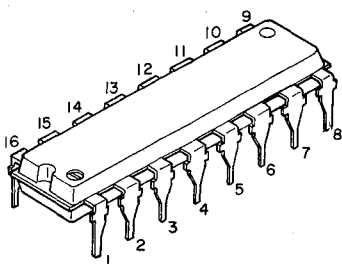

TC74HCU04P : IC1205●■▲

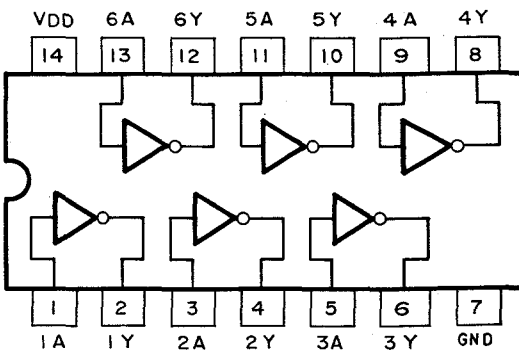
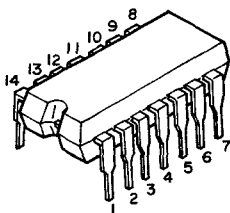

Notes : ● : Japanese model only (JA), ■ : West Germany model only (AD), ▲ : North American model only (UZ), ★ : Canadian model only (UQ), Others : Common.

CXA1082A : IC1301

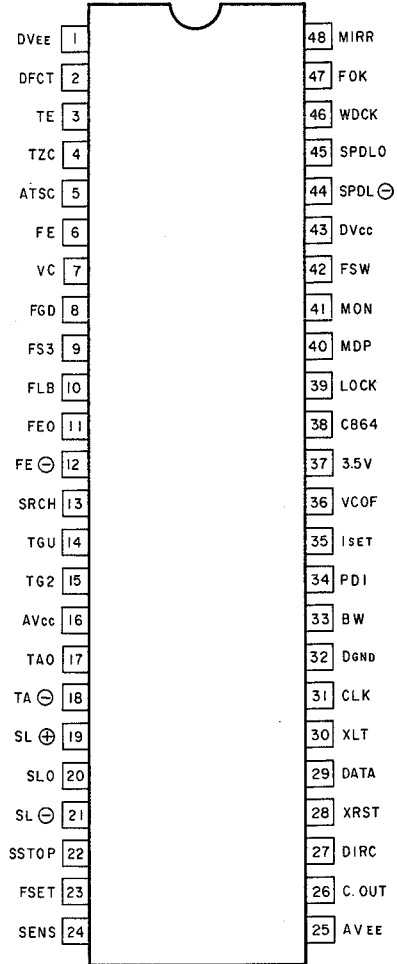
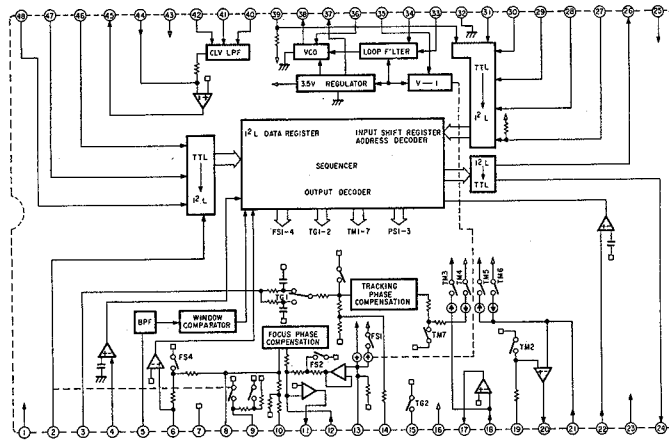
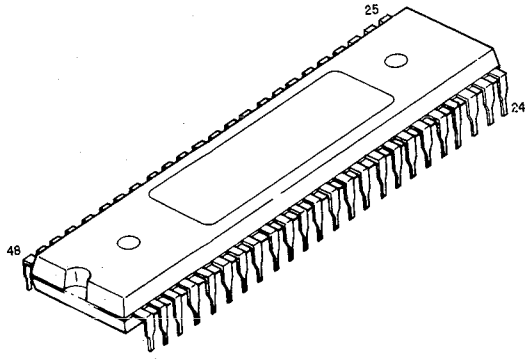

TC4053BP : IC1302

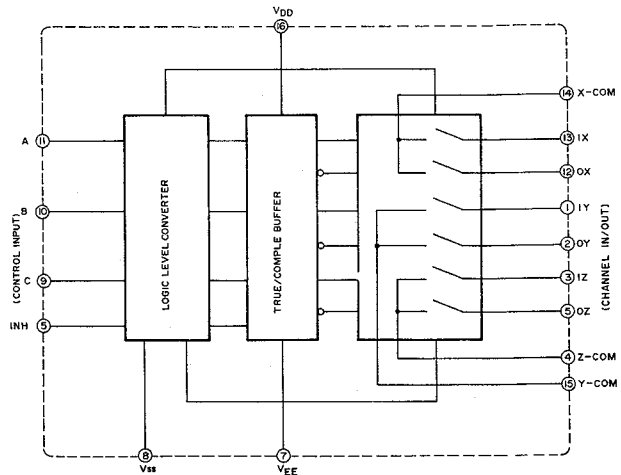
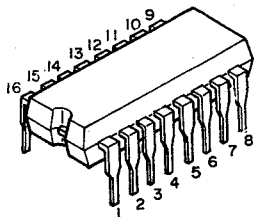

PCM56JP : IC1401

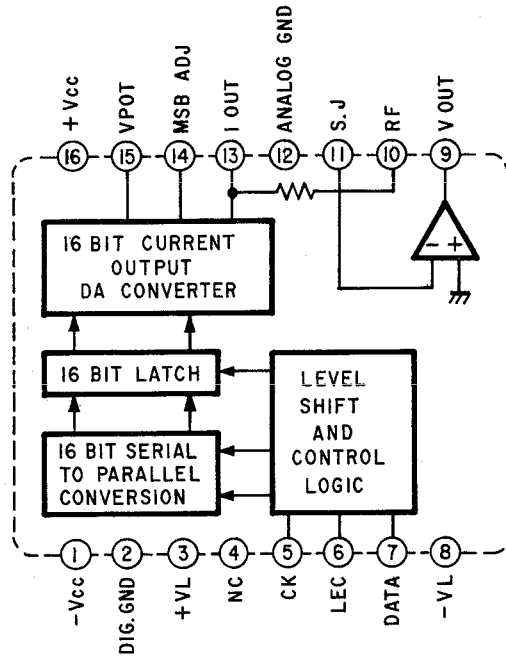
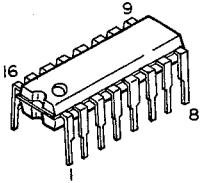

μ PD4053BC : IC1402

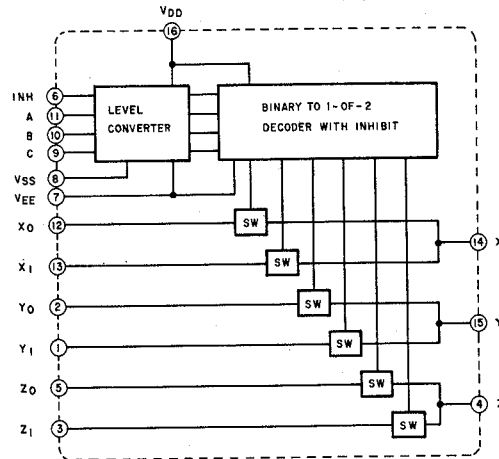
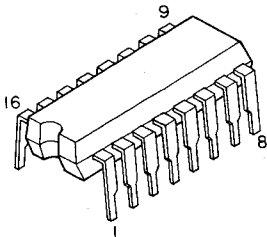

M5238P : IC1403, 1407, 1408

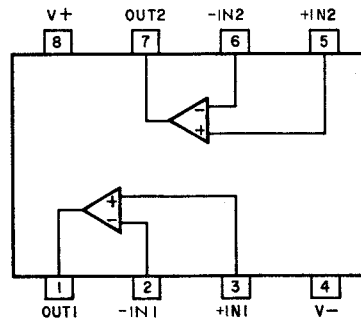
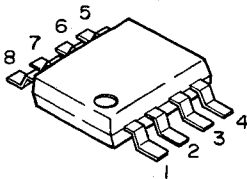

LP22D5B3YS : IC1405, 1406

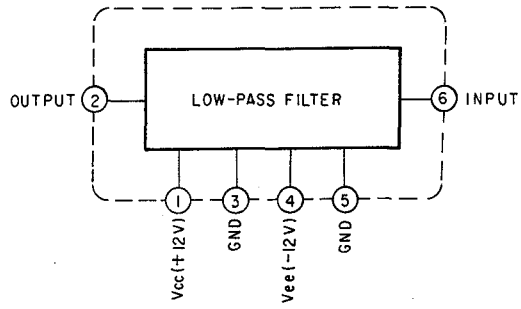
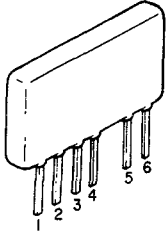

NJM2903D : IC1501

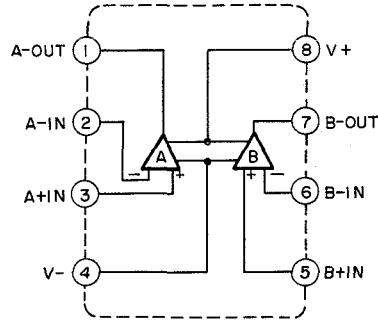
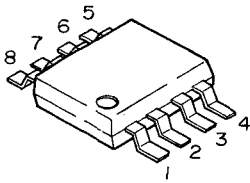

M6404A : IC1502

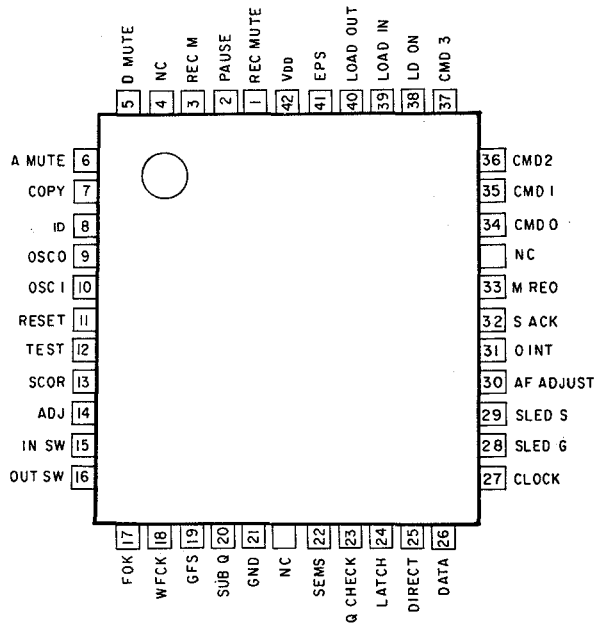
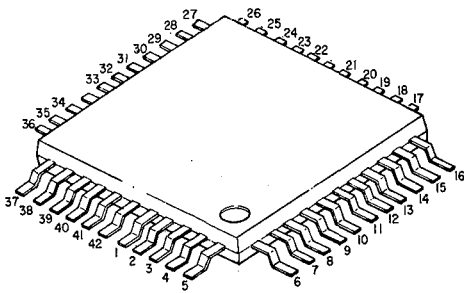

LA6500 : IC1503

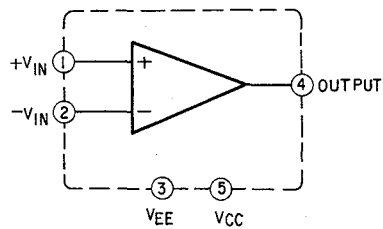
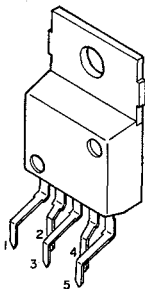

M5216P : IC4001

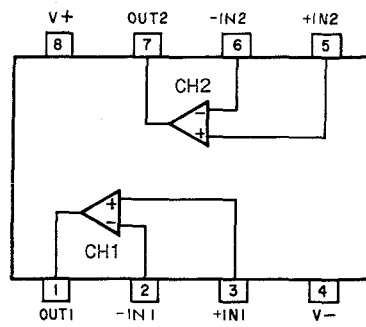
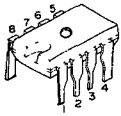

74753F01 : IC6001

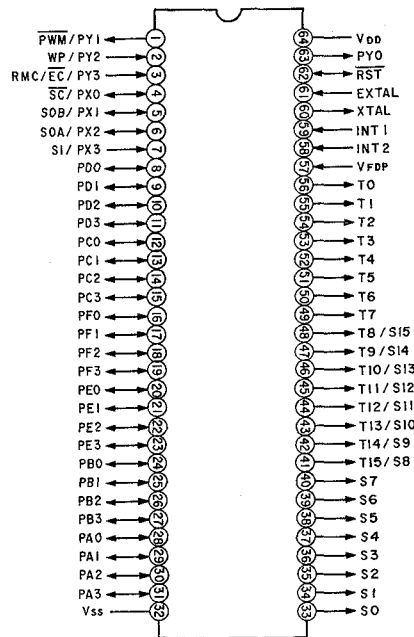
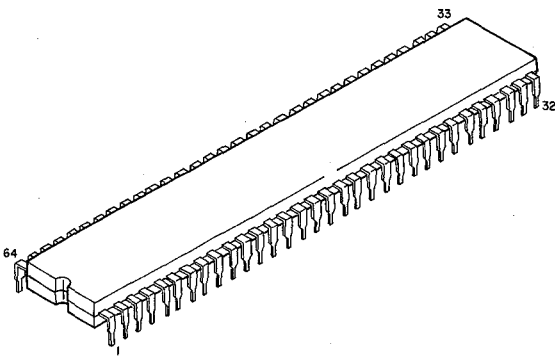

μ PD4028BC : IC6002

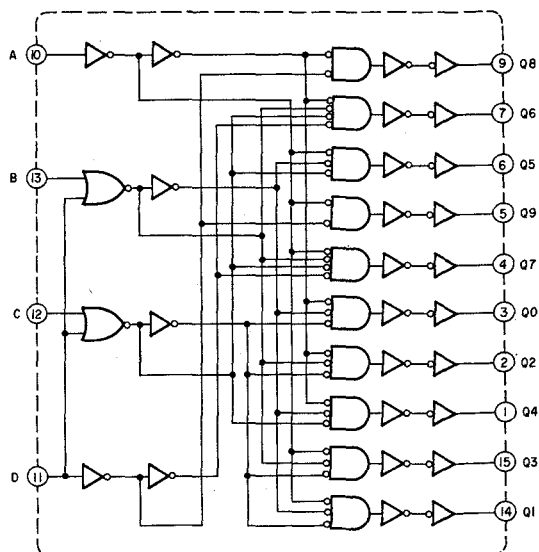
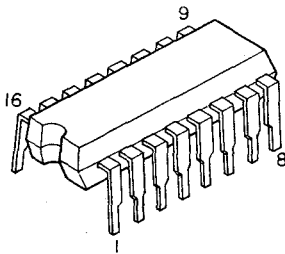

BX1387 : IC6003

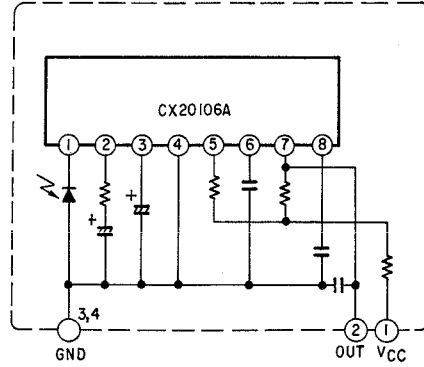
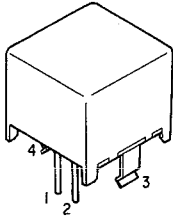

TOTX172 : IC9001

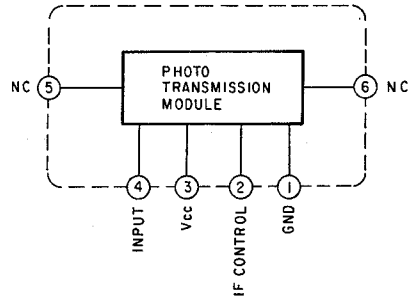
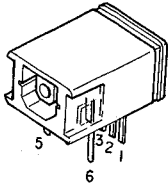

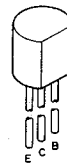

2SA1015 : Q1101, 1104, 1506
 2SC1815 : Q1102, 1103
 2SD1302 : Q1507 (★)

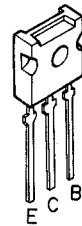

2SC3421 : Q1105
 2SA1358 : Q1106

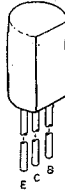
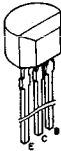
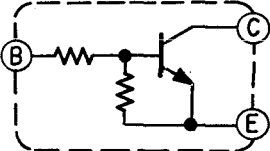
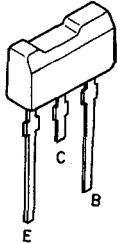

Notes : ● : Japanese model only (JA), ■ : West Germany model only (AD), ▲ : North American model only (UZ), ★ : Canadian model only (UQ), Others : Common.

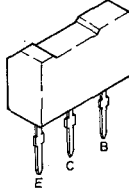
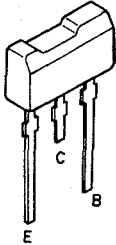
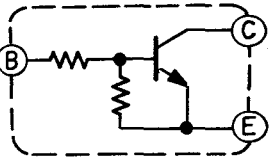
<p>2SB560 : Q1107, 1203</p>	
<p>DTC114 : Q1201, 1202, 1309, 1505, 1507 Q1310 (●, ■, ▲)</p>	 
<p>2SB1240 : Q1301, 1303, 1305, 1307 2SD1862 : Q1302, 1304, 1306, 1308</p>	
<p>2SK246 : Q1401, 1402</p>	
<p>2SA790 : Q6001</p>	
<p>DTC114EL : Q6003, 6004</p>	 

Notes : ● : Japanese model only (JA), ■ : West Germany model only (AD), ▲ : North American model only (UZ), ★ : Canadian model only (UQ), Others : Common.