

# SERVICE MANUAL

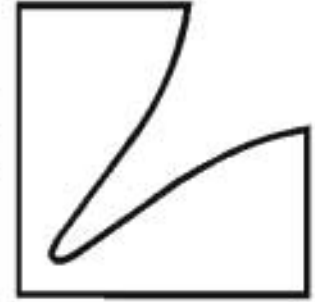

Auto Reverse Stereo Cassette Tape Deck

# K-406/K-106

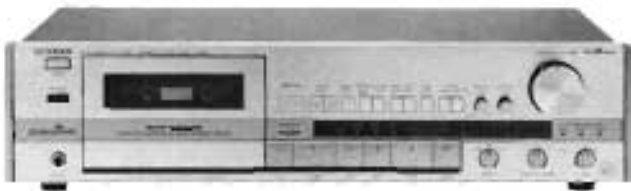

K-406



K-106

---

# Contents

---

Specifications . . . . . 3

Parts Locations and Disassembly Instructions . . . . . 4 to 8

Adjustment Procedures. . . . . 9 to 12

Adjustment Locations . . . . . 13 to 14

Block Diagram . . . . . 15

Replacement of Mechanical Parts . . . . . 16 to 18

Parts Layout on P.C. Boards and Wiring Diagram. . . . . 19 to 24

Schematic Diagram . . . . . 25 to 28

Electrical Parts List . . . . . 29 to 39

Parts List by Specific Countries . . . . . 40

Exploded View (Cabinet) . . . . . 41 to 42

Exploded View (Cassette Deck) . . . . . 43 to 44

Cabinet Assembly Parts List . . . . . 45 to 46

Cassette Deck Assembly Parts List . . . . . 47

Packing Method View. . . . . 48

Packing Assembly Parts List . . . . . 49

Semi-conductor Lead Identifications. . . . . 50 to 55

# Specifications

Power Source	220V, AC 50 Hz (K-106 AK, K-406 AK Model) 120V, AC 60 Hz (K-106 UZ/UQ, K-406 UZ/UQ Model) 100V, AC 50/60 Hz (K-106 JA Model)
Power Consumption	20W
Tape Speed	4.76 cm/sec. $\pm 1.5\%$
Wow & Flutter (JIS WTD Playback Mode)	0.09%
FF/REW Time (C-60)	120sec.
Frequency Response	Norm: 30 Hz $\sim$ 15 kHz CrO <sub>2</sub> : 30 Hz $\sim$ 16 kHz Metal: 30 Hz $\sim$ 18 kHz
Rec/Play Head	HEXALAM Permalloy core.
Erase Head	Double gaps ferrite core.
Load Impedance	Line Out: 47K ohm Head Phone: 8 ohm
S/N Ratio	NR-OFF: Norm 52 dB, CrO <sub>2</sub> /Metal 54 dB NR-B: Norm 57 dB, CrO <sub>2</sub> /Metal 59 dB NR-C: Norm 63 dB, CrO <sub>2</sub> /Metal 65 dB dbx: Norm 90 dB, CrO <sub>2</sub> /Metal 90 dB
Input Sensitivity	Line: 150mV $\pm 2$ dB
Output Level	Line Out: 550mV $\pm 3$ dB Head Phone: 65mV
Stereo Separation	35 dB
Distortion	3%
Semi-conductors	19 IC's, 124 Transistors, 3 Photo Transistors, 52 Diodes, 10 Zener Diodes
Dimensions	453(W) x 114(H) x 307(D) mm (K-406 Model) 438(W) x 114(H) x 307(D) mm (K-106 Model)
Weight	4.5 Kg (K-406 Model) 4.7 Kg (K-106 Model)

Specifications and appearance design subject to change without notice.

\* Noise reduction system manufactured under licence from Dolby Laboratories Licensing Corporation.

"Dolby" and the double-D symbol are trademarks of Dolby Laboratories Licensing Corporation.

\*\* dbx is the trade mark of dbx Incorporated.

# Parts Locations and Disassembly Instructions

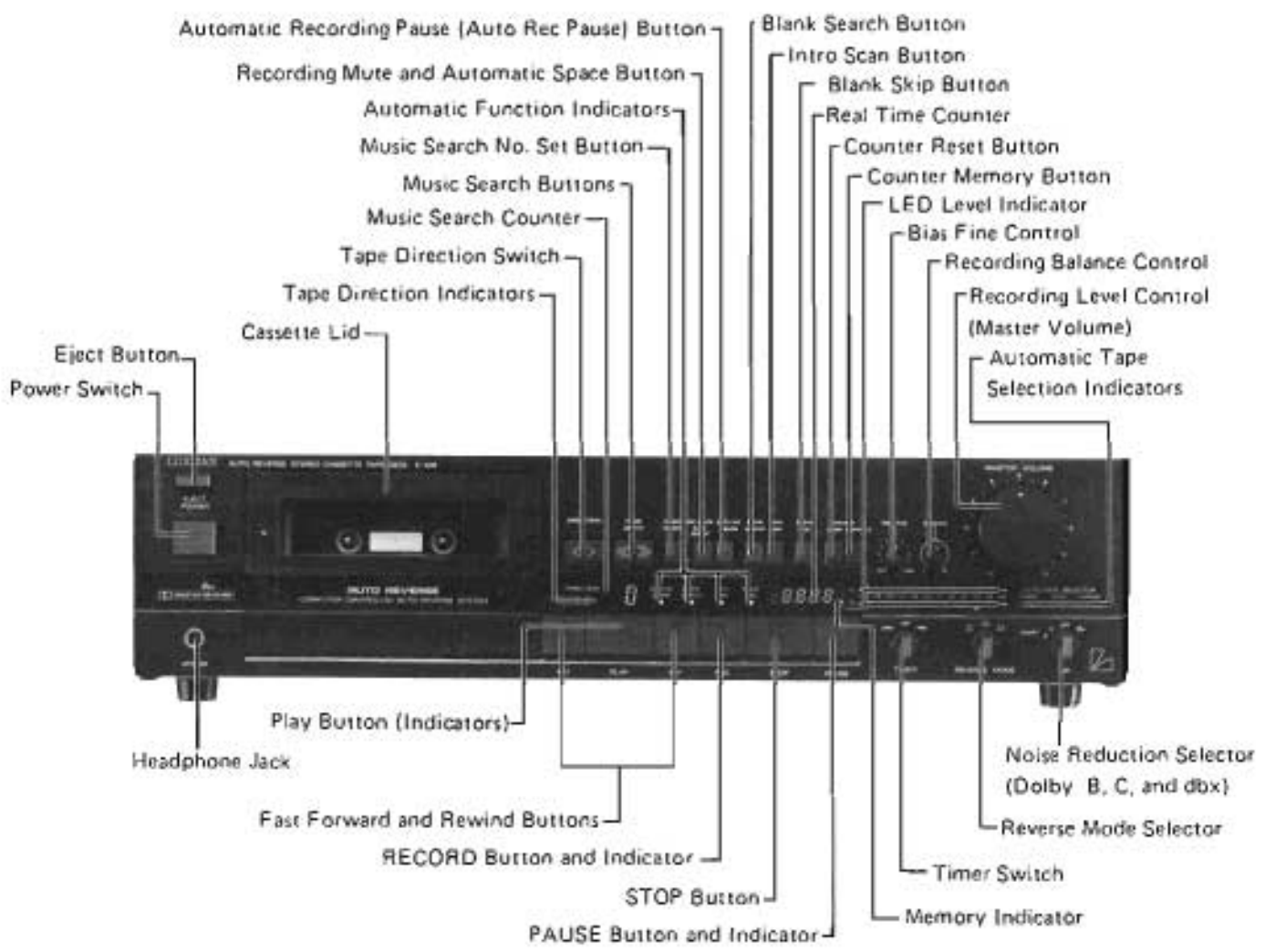

Figure 1

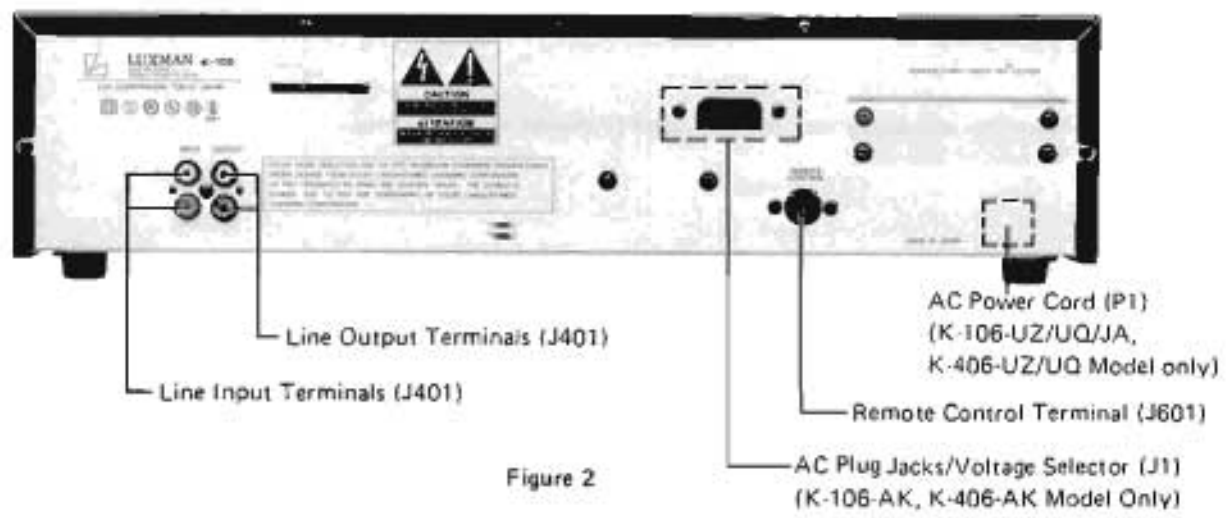

Figure 2

### 1. Removal of Top Cover

- (1) Remove six screws marked "○" as shown in Figures 3 and 4.

### 2. Removal of Cassette Deck

- (1) After removal of the top cover, remove the cassette door cover upward as shown in Figure 3.
- (2) Remove four screws marked "□" as shown in Figures 5 and 6.
- (3) Disconnect all lead wires from the cassette deck.

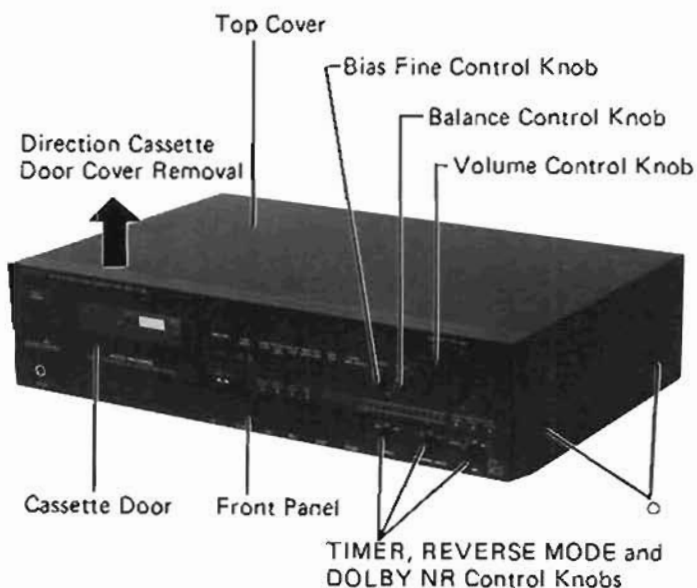

Figure 3

### 3. Removal of Front Panel

- (1) After removal of the top cover, remove six control knobs (VOLUME, BIAS FINE, BALANCE, TIMER, DOLBY NR and REVERSE MODE) as shown in Figure 3.
- (2) Remove five screws marked "X" as shown in Figure 5.
- (3) Remove three hooks (A) as shown in Figure 6.

### 4. Removal of Volume P.C. Board

- (1) After removal of the front panel, remove three nut and washers (a) as shown in Figure 7.
- (2) Disconnect all lead wires from the P.C. Board.

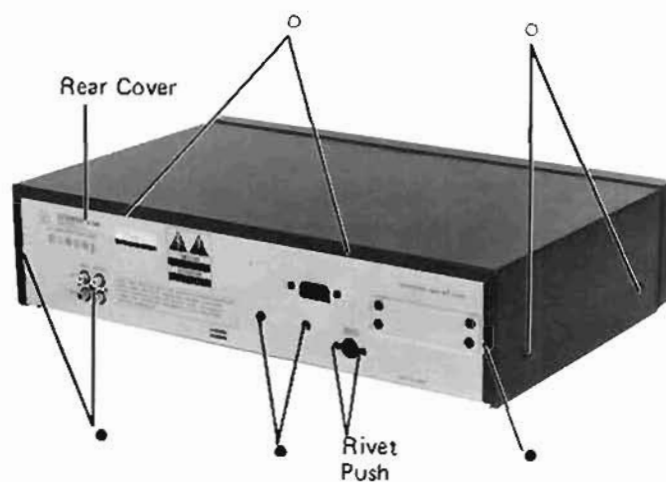

Figure 4

### 5. Removal of Headphone P.C. Board

- (1) After removal of the front panel, remove a nut and washer (b) as shown in Figure 7.
- (2) Disconnect all lead wires from the P.C. Board.

### 6. Removal of Bottom Cover

- (1) After removal of the cassette deck and the front panel, remove nine screws marked "△" as shown in Figures 5 and 6.

### 7. Removal of Key Switch P.C. Board

- (1) After removal of the bottom cover and the volume P.C. Board, disconnect six parallel wires from the Master P.C. Board as shown in Figure 9, by removing the solder (a).
  - \* Do not cut parallel wire when removing the solder (a).
- (2) Remove a screw marked "●" as shown in Figure 8.
- (3) Remove eight hooks (B) as shown in Figures 6 and 8.
- (4) Disconnect all lead wires from the P.C. Board.

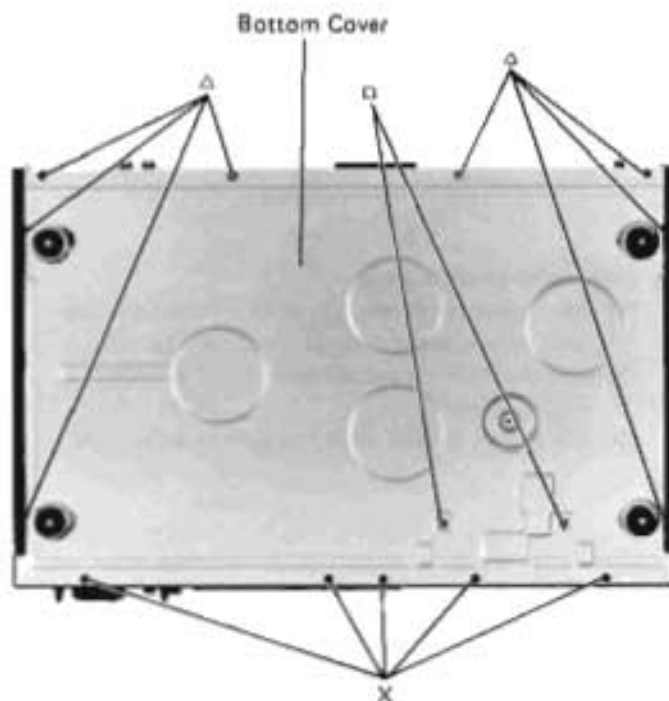

Figure 5

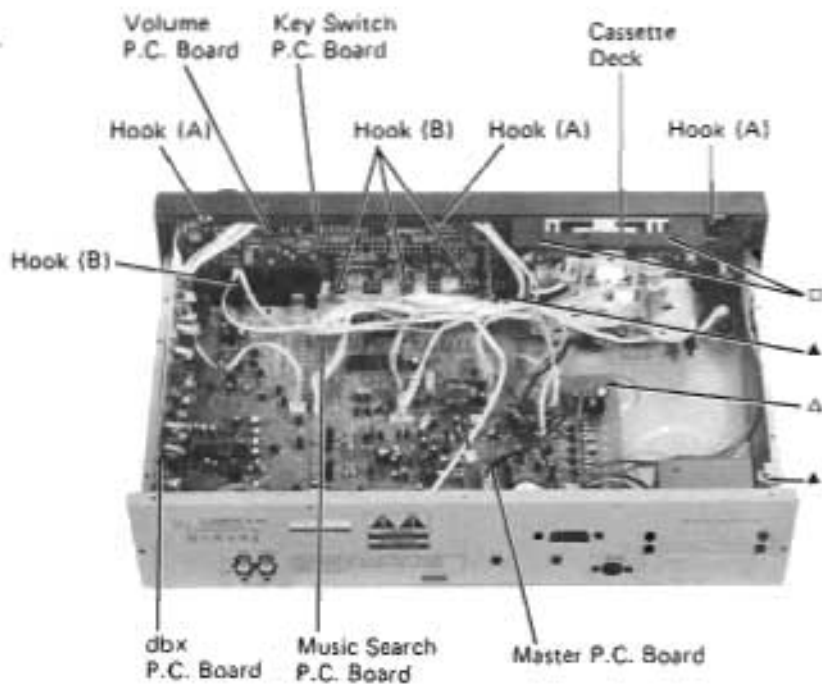

Figure 6

### 8. Removal of Rear Cover

- (1) After removal of the bottom cover, remove five screws marked "●" as shown in Figure 4.
- (2) Remove two rivet pushes as shown in Figure 4.
- (3) Disconnect all lead wires from the power switch.

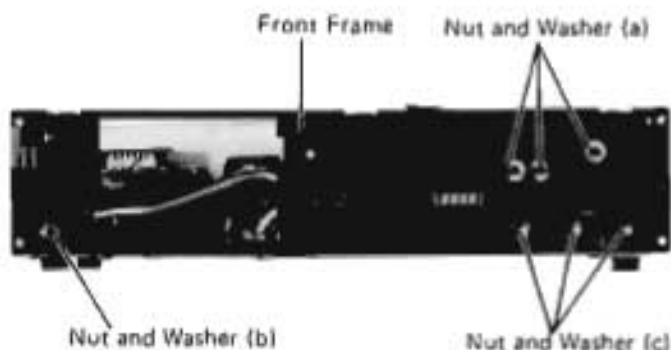

Figure 7

### 9. Removal of Master P.C. Board

- (1) After removal of the rear cover, remove the solder (a) as shown in Figure 9.
- (2) Remove three nut and washers (c) as shown in Figure 7.
- (3) Remove two screws marked "▲" as shown in Figure 6.
- (4) Disconnect all lead wires from the P.C. Board.
- (5) Master P.C. Board with the dbx and Music Search P.C. Board can be removed completely.

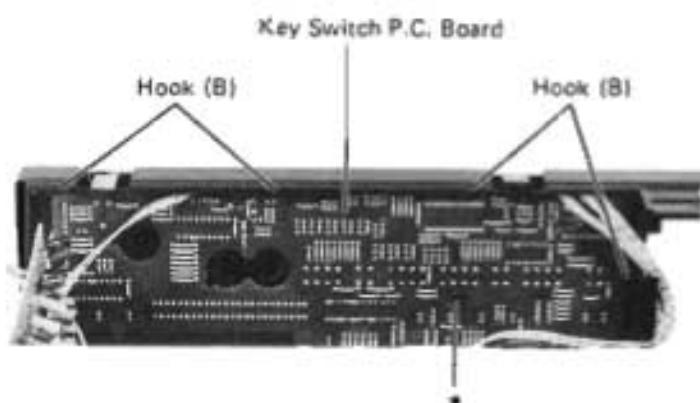

Figure 8

### 10. Removal of dbx P.C. Board

- (1) After removal of the Master P.C. Board, remove the solder (b) as shown in Figure 9.

### 11. Removal of Music Search P.C. Board

- (1) After removal of the Master P.C. Board, remove the solder (c) as shown in Figure 9.
- (2) Disconnect all lead wires from the P.C. Board.

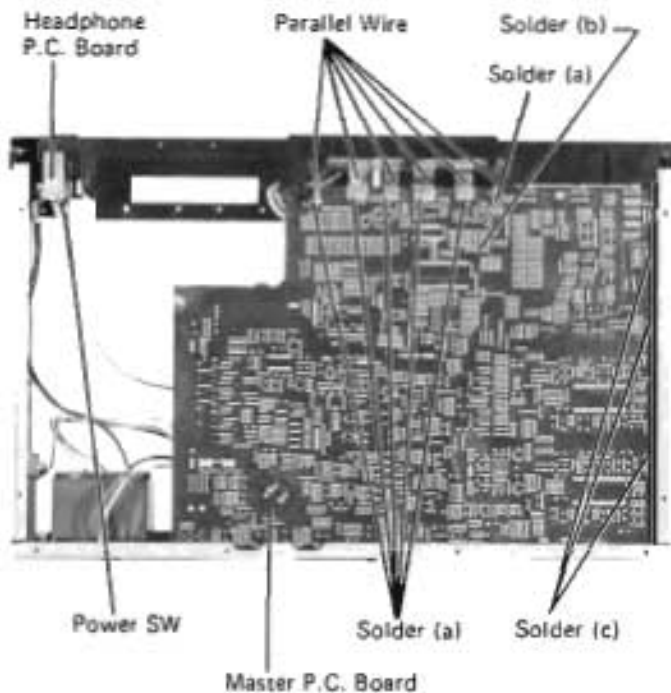

Figure 9

## 分解方法

1. 上蓋の外し方
  - (1) 図3, 4に示す6本のネジ(○印)を外します。
2. カセット・デッキの外し方
  - (1) 上蓋を外した後、図3に示すカセット・ドア・カバーを上へ引き上げるようにして外します。
  - (2) 図5, 6に示す4本のネジ(□印)を外します。
  - (3) カセット・デッキに接続する全てのリード線を外します。
3. フロント・パネルの外し方
  - (1) 上蓋を外した後、図3に示す6個のコントロール・ツマミ(ボリューム, バイパス・ファイン, バランス, タイマー, ドルビー・NR, リバースモード)を外します。
  - (2) 図5に示す5本のネジ(×印)を外します。
  - (3) 図6に示す3個のツメ(A)を外します。
4. ボリューム基板の外し方
  - (1) フロントパネルを外した後、図7に示す3個のナットとワッシャー(a)を外します。
  - (2) 基板に接続する全てのリード線を外します。
5. ヘッドホン基板の外し方
  - (1) フロントパネルを外した後、図7に示す1組のナットとワッシャー(b)を外します。
  - (2) 基板に接続する全てのリード線を外します。
6. 底蓋の外し方
  - (1) カセット・デッキとフロントパネルを外した後、図5, 6に示す9本のネジ(△印)を外します。
7. キー・スイッチ基板の外し方
  - (1) 底蓋とボリューム基板を外した後、図9に示すハンダ(a)を外して、6組の平行リード線をマスター基板から外します。  
\*ハンダ(a)を外す時、平行リード線を切らない様にして下さい。
  - (2) 図8に示す1本のネジ(★印)を外します。
  - (3) 図6, 8に示す9個のツメ(B)を外します。
  - (4) 基板に接続する全てのリード線を外します。
8. リア・カバーの外し方
  - (1) 底蓋を外した後、図4に示す5本のネジ(●印)を外します。
  - (2) 図4に示す2本のリベットブッシュを外します。
  - (3) 基板に接続する全てのリード線を外します。
9. マスター基板の外し方
  - (1) リア・カバーを外した後、図9に示すハンダ(a)を外します。
  - (2) 図7に示す3組のナットとワッシャー(c)を外します。
  - (3) 図6に示す2本のネジ(▲印)を外します。
  - (4) 基板に接続する全てのリード線を外します。
  - (5) マスター基板(dbx基板, ミュージック・サーチ基板付)を外します。
10. dbx基板の外し方
  - (1) マスター基板を外した後、図9に示すハンダ(b)を外します。
11. ミュージック・サーチ基板の外し方
  - (1) マスター基板を外した後、図9に示すハンダ(c)を外します。
  - (2) 基板に接続する全てのリード線を外します。



## Adjustment Procedures

Step	Description	Mode	Adjust Point	Test Point	Connection Instruction	Remarks	
1	Head Azimuth Adjustment	Play NR: Off	Head Azimuth Screw (Figure 17)	Line Out	Figure 10	Test Tape: MTT-114 Adjust to Maximum and same phase at Normal and Reverse Positions.	
2	Tape Speed Adjustment	Play NR: Off	Round hole on the rear of the motor (Figure 18)	Line Out	Figure 10	Test Tape: MTT-111 Adjust to 3000 ~ 3005 Hz at test tape center position of Normal direction.	
3	Playback Gain Adjustment	Play NR: Off	VR201(L) VR202(R)	Line Out	Figure 10	Test Tape: MTT-150 Line Out: 560mV	
4	Quick Reverse Adjustment	Play FWD Mode: Oneway (⇌) Direction: Normal NR: Off	VR602	TP601	Figure 11	Test Tape: Blank Test Point Output: 2V	
5	Input Level Adjustment	Rec/Play NR: Off	VR431(L) VR432(R)	Line Out	Figure 12	Test Tape: AC-712 Line Input: 400 Hz, 150mV Line Output: 560mV	
6	Level Meter Adjustment	Rec/Pause NR: Off	VR8101(L) VR8102(R)	Level Meter	Figure 12	Conditions at step 5. Test Tape: Blank Adjust just to turn off 3rd red LED.	
7	Bias Frequency Adjustment	Rec/Play NR: Off	T501	TP503	Figure 13	Test Tape: AC-712 Adjust to 105 kHz.	
8	Bias Trap Adjustment	Rec/Play NR: Off	LF501(L) LF502(R)	TP501(L) TP502(R)	Figure 14	Test Tape: AC-712 Adjust to minimum amplitude.	
9	Record/Playback Level Bias Adjustment	Rec/Play NR: Off	VR501(L) VR502(R)	Line Out	Figure 15	Conditions at step 5. Test Tape: AC712 Adjust distortion to 0.9mA 1.6%.	
10	Record/Playback Frequency Response Adjustment	Rec/Play NR: Off		Line Out	Figure 12	Conditions at step 5. Adjust AF OSC LEVEL to -25 dB of LINE OUT output. Adjust to 0 dB output with AF OSC frequency 400 Hz and 14 kHz at each tape position.	
			VR5101, 5102			AC712	METAL
			VR5103, 5104			AC512	CrO <sub>2</sub>
			VR5105, 5106			AC223	NORMAL
11	dbx Level Adjustment	STOP NR: dbx	VR3001 (DEC) VR3101 (ENC)	TP3001 (DEC) TP3002 TP3101 (ENC) TP3102	Figure 16	Adjust to 15mV DC.	

### Control Setting

Power Switch . . . . . ON  
NR Switch . . . . . OFF

REVERSE MODE Switch . . . Center Position (⇌)  
TIMER Switch . . . . . OFF

## 調整方法

手順	調整項目	モード	調整箇所	テストポイント	接続	備 考		
1	ヘッド アジマス調整	再生 NR:Off	ヘッドアジマス ねじ (17箇所)	ライン出力	図10	テストテープ: HTT-114 最大に調整。ノーマル、リバース位置においても同位相。		
2	テープ スピード調整	再生 NR:Off	モーター後側の 丸い穴 (18箇所)	ライン出力	図10	テストテープ: HTT-111 テストテープが順方向、中心位置で3000~3005Hzになる ように調整。		
3	再生利得調整	再生 NR:Off	VR201(L) VR202(R)	ライン出力	図10	テストテープ: HTT-150 ライン出力: 560mV		
4	クイック リバース調整	再生、リバ ースモード 1方向(←) ノーマル NR:Off	VR602	TP601	図11	テストテープ: ブランク テストポイント出力: 2V		
5	入力レベル 調整	録音/再生 NR:Off	VR431(L) VR432(R)	ライン出力	図12	テストテープ: AC-712 ライン入力: 400Hz, 150mV ライン出力: 560mV		
6	レベル メーター 調整	録音/ 一時停止 NR:Off	VR8101(L) VR8102(R)	レベル メーター	図12	手順5の状態。 テストテープ: ブランク 3番目のランプ(赤)が消えるように調整。		
7	バイアス 周波数調整	録音/再生 NR:Off	T501	TP503	図13	テストテープ: AC-712 105kHzになるように調整。		
8	バイアス トラップ調整	録音/再生 NR:Off	LF501(L) LF502(R)	TP501(L) TP502(R)	図14	テストテープ: AC-712 最小振幅に調整。		
9	録音/再生 レベル バイアス調整	録音/再生 NR:Off	VR501(L) VR502(R)	ライン出力	図15	手順5の状態。 テストテープ: AC-712 0.9mA 1.6% に歪率を調整。		
10	録音/再生 周波数 レスポンス 調整	録音/再生 NR:Off		ライン出力	図12	手順5の状態。 ライン出力側の出力を-25dB になるようにAF OSCレベルを調整 AF OSC周波数が400Hz の時出力が0dB になるように調整。 下に示すテープ位置でAF OSC周波数が14kHz の時出力が0dB になるように調整。		
			VR5101, 5102				AC712	メタル
			VR5103, 5104				AC512	クローム
			VR5105, 5106				AC223	ノーマル
11	dbxレベル 調整	停止 NR:dbx	VR3001(DEC) VR3101(ENC)	TP3001(DEC) TP3002(DEC) TP3101(ENC) TP3102(ENC)	図16	15mV DC になるように調整。		

## スイッチ類のセット位置

- ・電源スイッチ . . . . . ON
- ・リバースモードスイッチ . . . . . 中央 (←)
- ・NRスイッチ . . . . . OFF
- ・タイマースイッチ . . . . . OFF

Connections

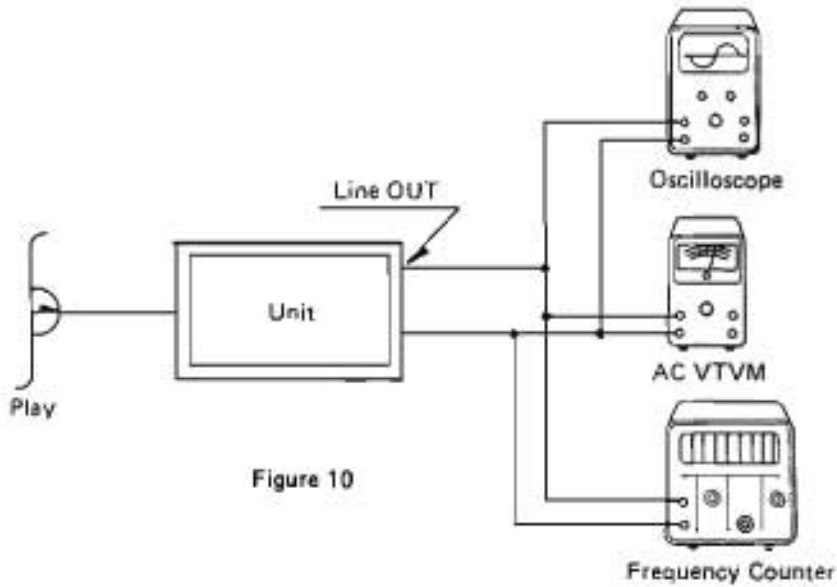

Figure 10

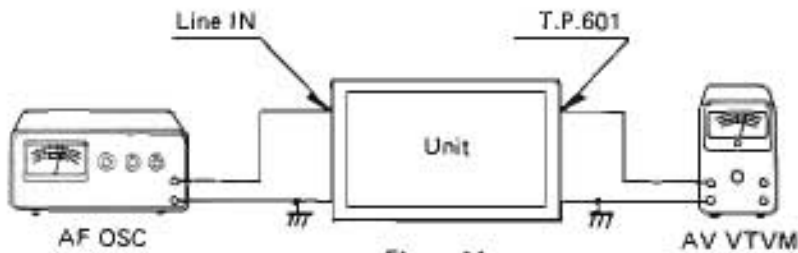

Figure 11

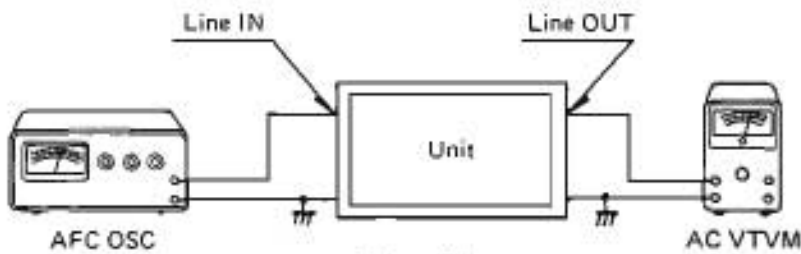

Figure 12

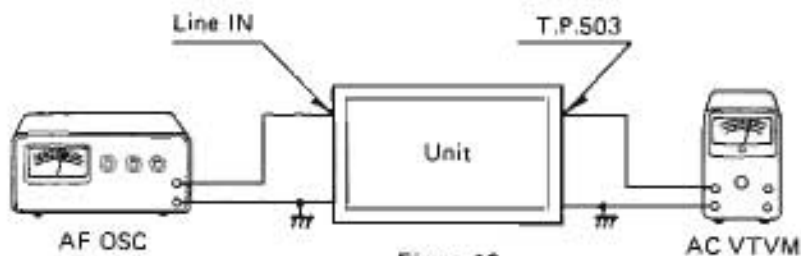

Figure 13

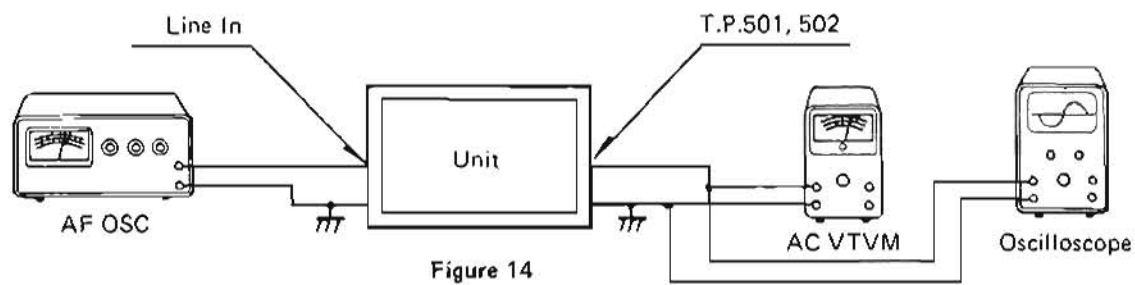

Figure 14

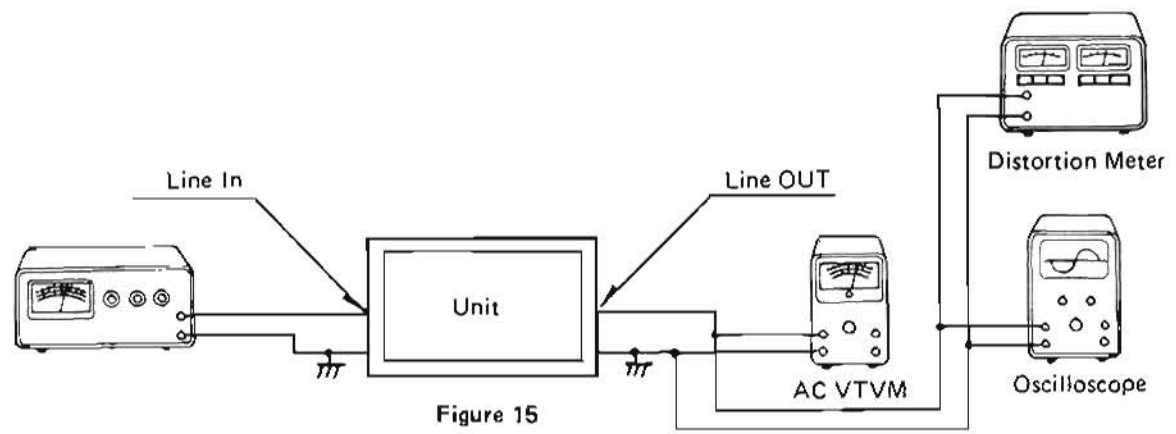

Figure 15

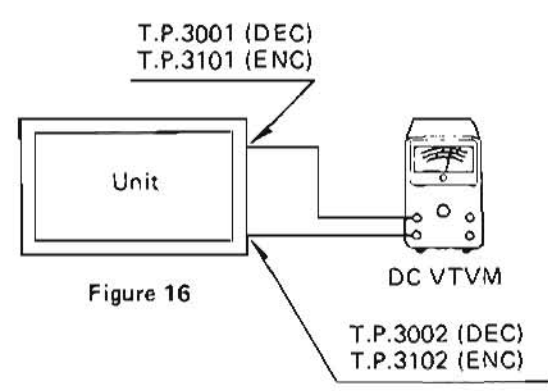

Figure 16

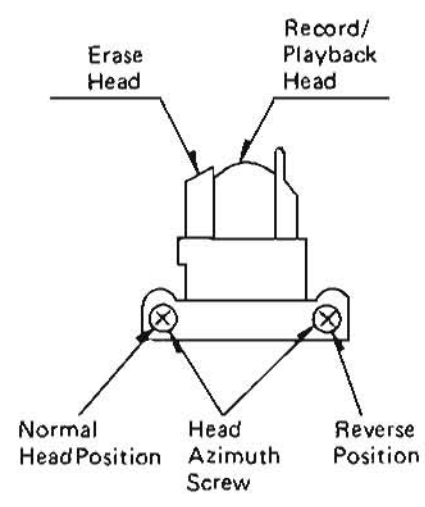

Figure 17

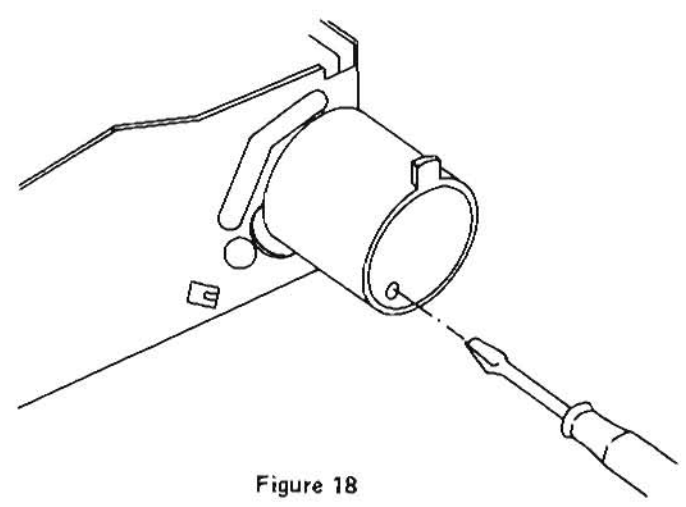
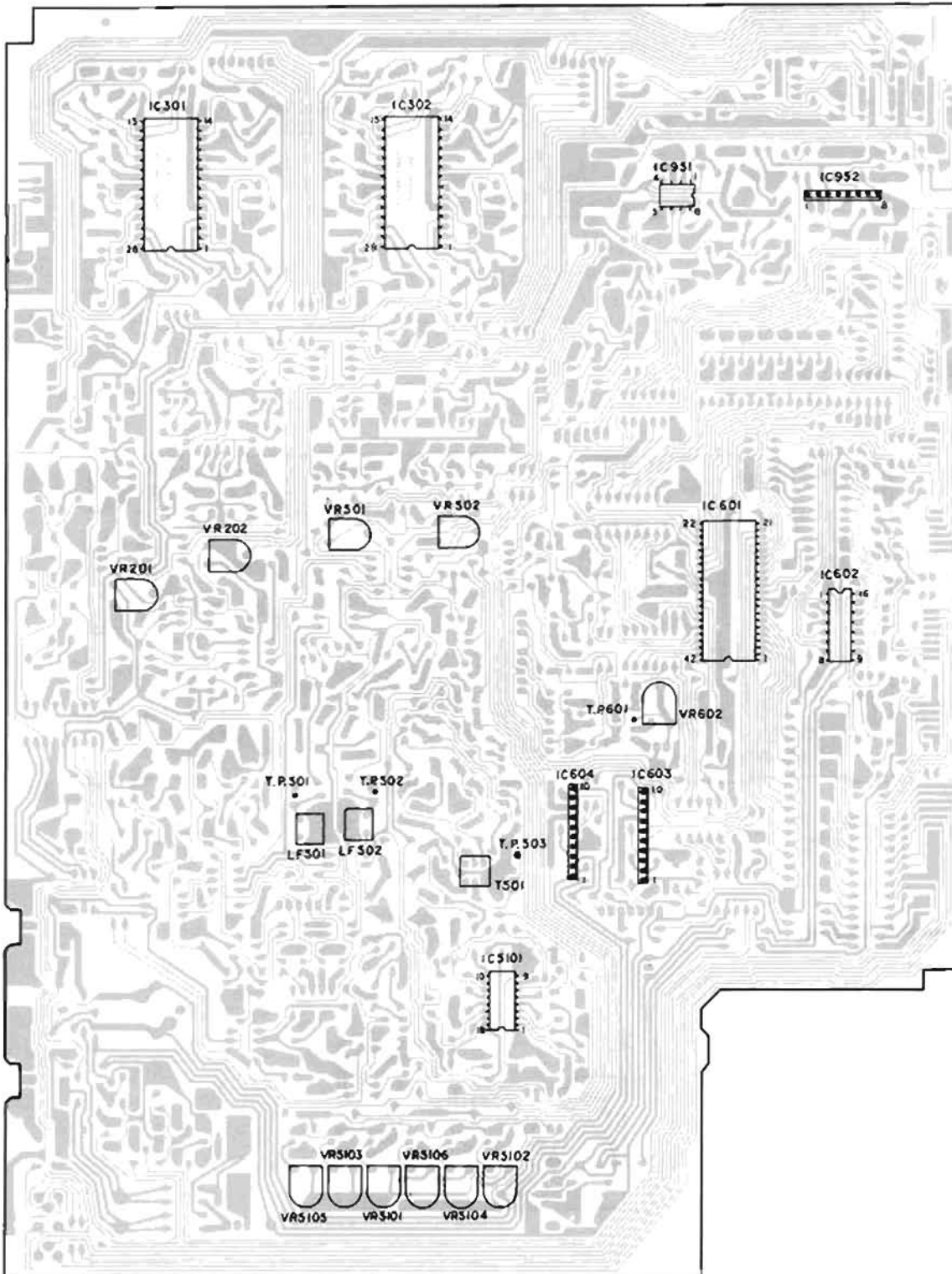

Figure 18

# Adjustment Locations

- Main P.C. Board



● Key Switch P.C. Board

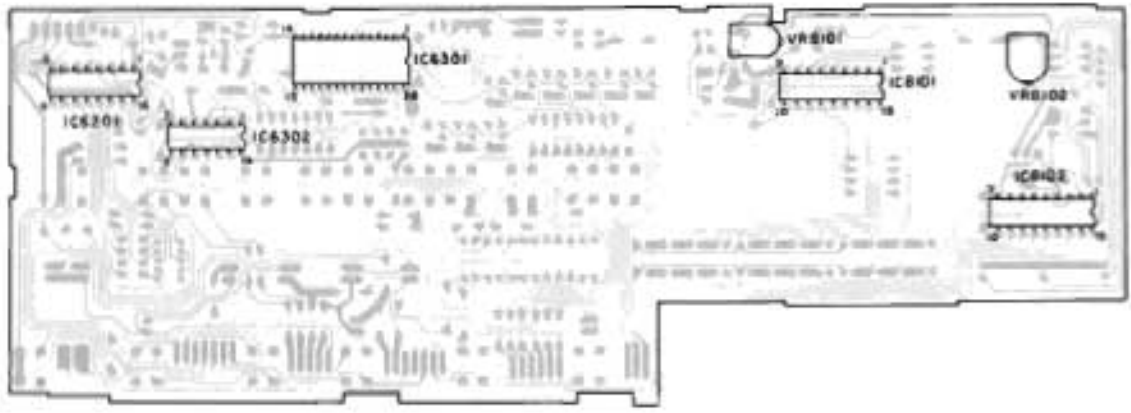

● dbx P.C. Board

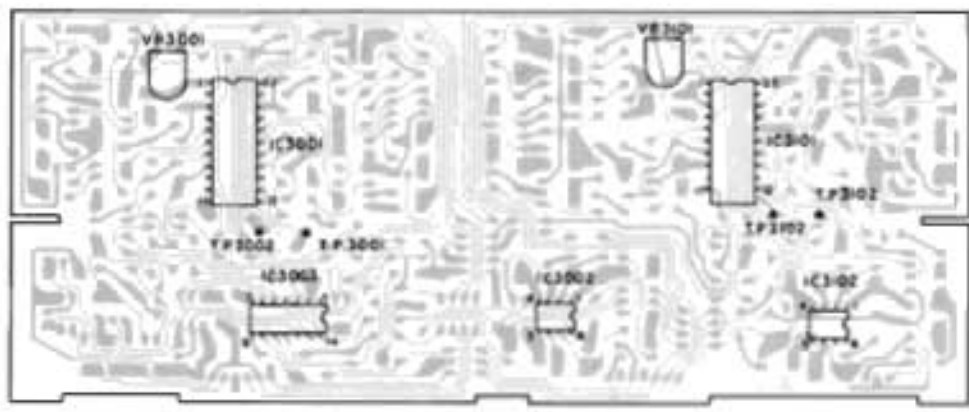

● Volume P.C. Board

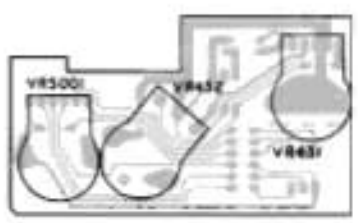

# Block Diagram

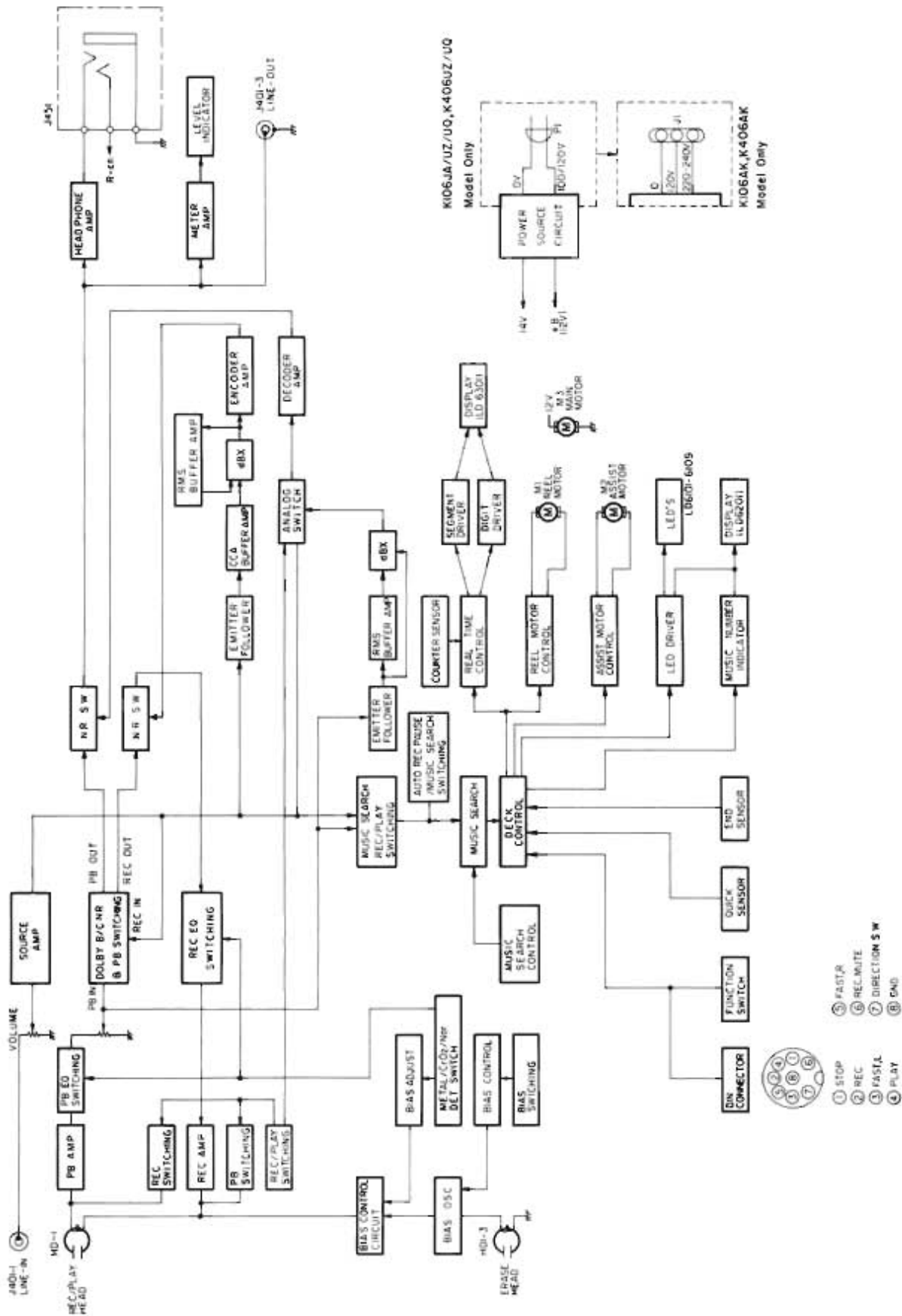

## Replacement of Mechanical Parts

### • Removal of Cassette Deck Assembly

Prior to Replacement Procedures, remove the Cassette Deck Assembly, according to "Removal of Cassette Deck Assembly" on page 4.

### 1. Preparation for Replacement of Pinch Rollers and Turning Head

(1) Remove two screws marked "○" as shown in Figure 19, and Dumper Bracket and Door Frame can be removed.

#### 1-1. Replacement of Pinch Roller (L) (and Pinch Roller (R))

- (1) Remove "E" Ring marked "●" (and "△") as shown in Figure 20, and Pinch Roller (L) (and (R)) can be removed.
- (2) Replace the Pinch Roller (L) (and (R)) with a new one, and clean it with absolute alcohol.
- (3) Assemble the unit in the way reverse to disassembly, and confirm wow/flutter and tape speed according to "Adjustment Procedures".

#### 1-2. Replacement of Turning Head

- (1) Remove two nuts marked "▲" as shown in Figure 20, and remove sensor and tape guide.
- (2) Remove two screws marked "□" as shown in Figure 20, and one screw marked "■", Lead Holder as shown in Figure 19.
- (3) Replace the turning head with a new one and clean it with absolute alcohol, and assemble the unit in the way reverse to disassembly.
- (4) Confirm the position of tape guide and sensor, and adjust Head Azimuth, "Adjustment Procedures".

### 2. Preparation for Replacement of Motors, Main Belt and Flywheels

- (1) Remove four screws marked "☆" and one screw marked "◆" as shown in Figure 19.
  - (2) Motor Bracket and Connector P.C. Board can be removed as shown in Figure 21.
- After assembly of the unit with any replacement, tape speed and wow/flutter must be confirmed with "Adjustment Procedures".

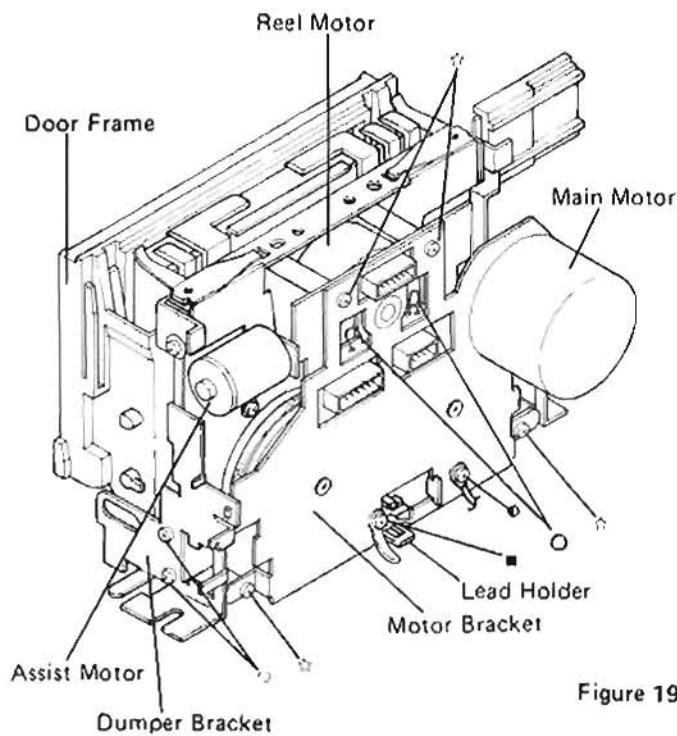

Figure 19

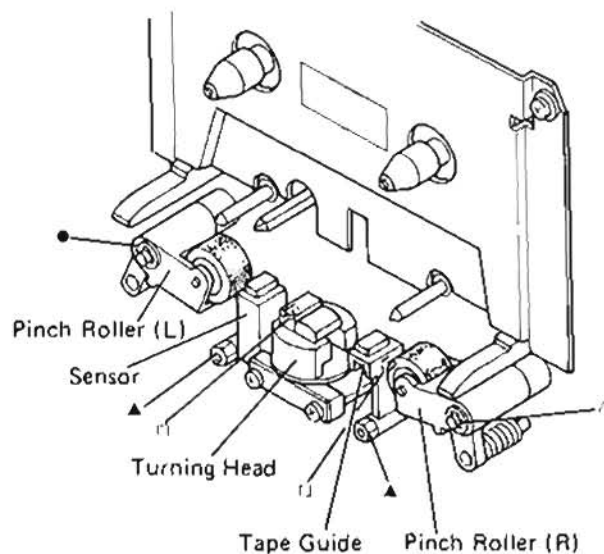

Figure 20



### 2-1. Replacement of Main Motor.

- (1) Remove two screws marked "★" as shown in Figure 21, and disconnect two lead wires of Main Motor.
- (2) Replace the Main Motor with a new one, and assemble the unit in the way reverse to disassembly.

### 2-2. Replacement of Reel Motor

- (1) Remove two solders marked "◎" as shown in Figure 19, and replace the reel motor with a new one.
- (2) Assemble the unit in the way reverse to disassembly.

### 2-3. Replacement of Assist Motor

- (1) Remove a screw marked "☒" as shown in Figure 21, and Assist Motor Bracket will be removed as shown in Figure 22.
- (2) Remove two screws marked "◎" as shown in Figure 22, and disconnect two lead wires of assist motor.
- (3) Replace the assist motor with a new one, and assemble in the way reverse to disassembly.

### 2-4. Replacement of Main Belt and Flywheels

- (1) Replace the bad part with new one, and clean it with absolute alcohol.
- (2) Assemble the unit in the way reverse to disassembly.

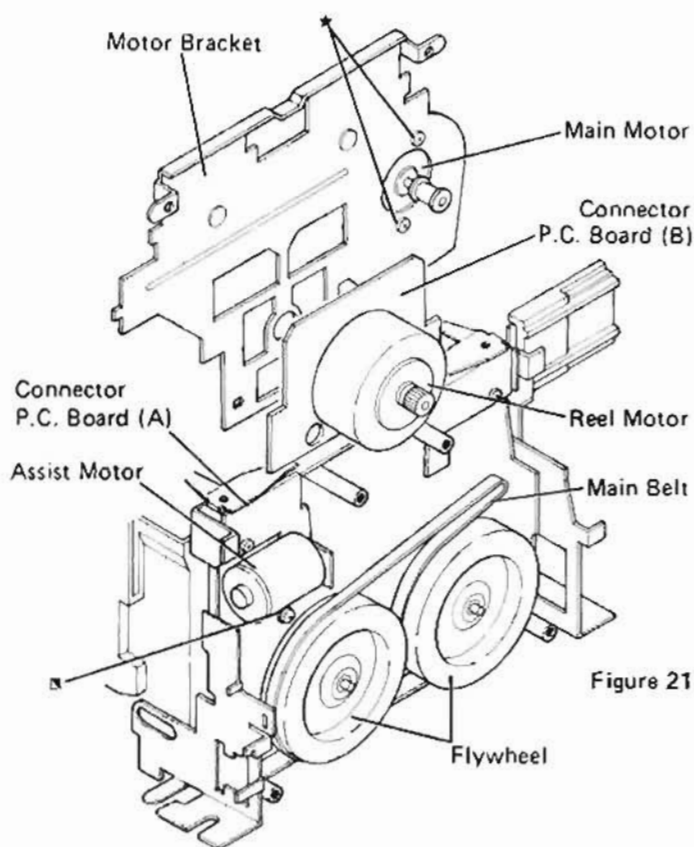

Figure 21

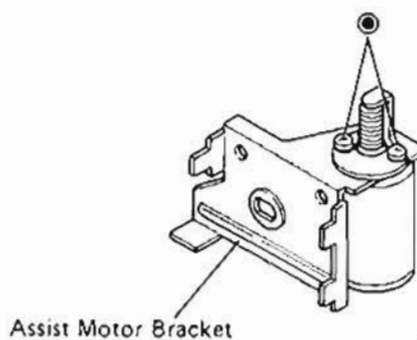

Figure 22

## 機構部品の交換方法

### ※カセット・デッキ組立の外し方

交換方法の実施前にカセットデッキ組立を7頁の“カセット・デッキの外し方”に従い、取り外す。

#### 1. ピンチ・ローラおよび回転ヘッド交換の準備

- (1) 図19に示された、“○”印のネジ2本を取り外すとダンパー・ブラケットとドア枠を取り外すことができる。

#### 1-1. ピンチ・ローラ(L)(および(R))の交換

- (1) 図20に●印(および“△”印)で示されたEリングを取り外すと、ピンチ・ローラ(L)(およびR)を外すことができる。
- (2) ピンチ・ローラ(L)(および(R))を新しいものと交換し、無水アルコールで拭く。
- (3) 分解と逆の手順で本体を組み立てる。次に“調整手順”に従いワウフラッターおよびテープ・スピードを確認する。

#### 1-2. 回転ヘッドの交換

- (1) 図20に示された、“▲”印のナット2本を取り外す。次に、センサーとテープ・ガイドを取り外す。
- (2) 図20に“□”印で示されたネジ2本と、図19に“■”印で示されたネジとリード・ホルダーを取り外す。
- (3) 回転ヘッドを新しいものと交換し、無水アルコールで拭く。次に、分解と逆の手順で本体を組み立てる。
- (4) テープ・ガイドとセンサーの位置を確認し、“調整手順”に従いヘッド・アジマス进行调整する。

#### 2. モーター、メイン・ベルト、フライホイールの交換準備

- (1) 図19に示された、“☆”印のネジ4本と“◎”印のネジ1本を取り外す。
- (2) 図21に示す様にモーター・ブラケットおよびコネクター基板を、取り除くことができる。  
交換後の組立においては、テープ・スピードおよびワウ・フラッターを“調整手順”に従って確認すること。

#### 2-1. メイン・モーターの交換

- (1) 図21に示された、“★”印のネジ2本を取り外す。次に、メイン・モーターの2本のリード線を外す。
- (2) メイン・モーターを新しいものと交換し、分解と逆の手順で組み立てる。

#### 2-2. リール・モーターの交換

- (1) 図19に示された、“◎”印のハンダ付け2箇所を取り外し、リール・モーターを新しいものと交換する。
- (2) 分解と逆の手順で本体を組み立てる。

#### 2-3. 補助モーターの交換

- (1) 図21に示された、“■”印のネジを取り外すと、図22に示す様に補助モーター・ブラケットを外すことができる。
- (2) 図22に示された、“◎”印のネジ2本を取り外し、補助モーターの2本のリード線を外す。
- (3) 補助モーターを新しいものと交換し、分解と逆の手順で組み立てる。

#### 2-4. メイン・ベルトおよびフライホイールの交換

- (1) 摩耗箇所を新しいものと交換し、無水アルコールで拭く。
- (2) 分解と逆の手順で組み立てる。

Parts Layout on P.C. Boards and Wiring Diagram (1/2)

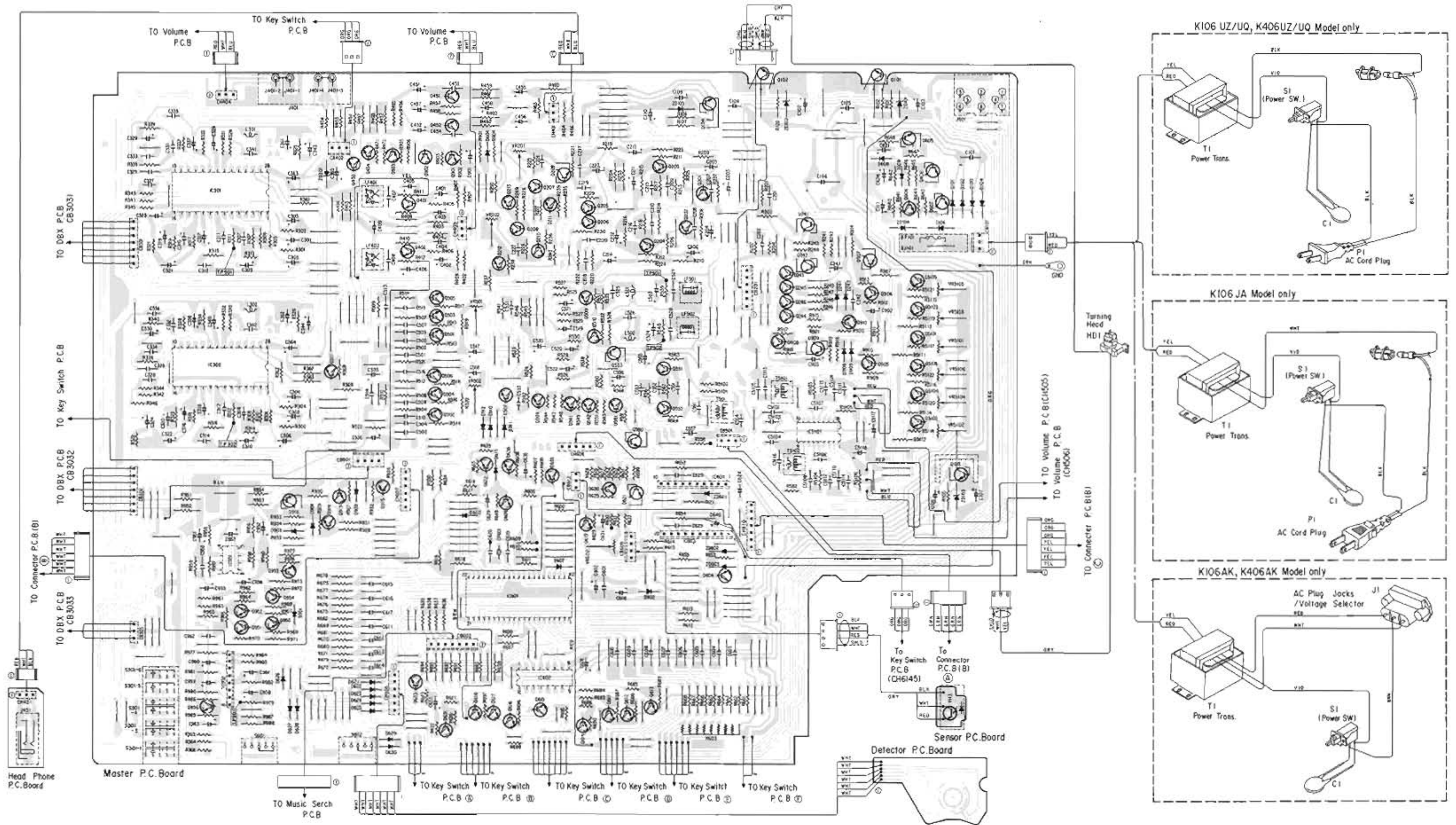



Parts Layout on P.C. Boards and Wiring Diagram (2/2)

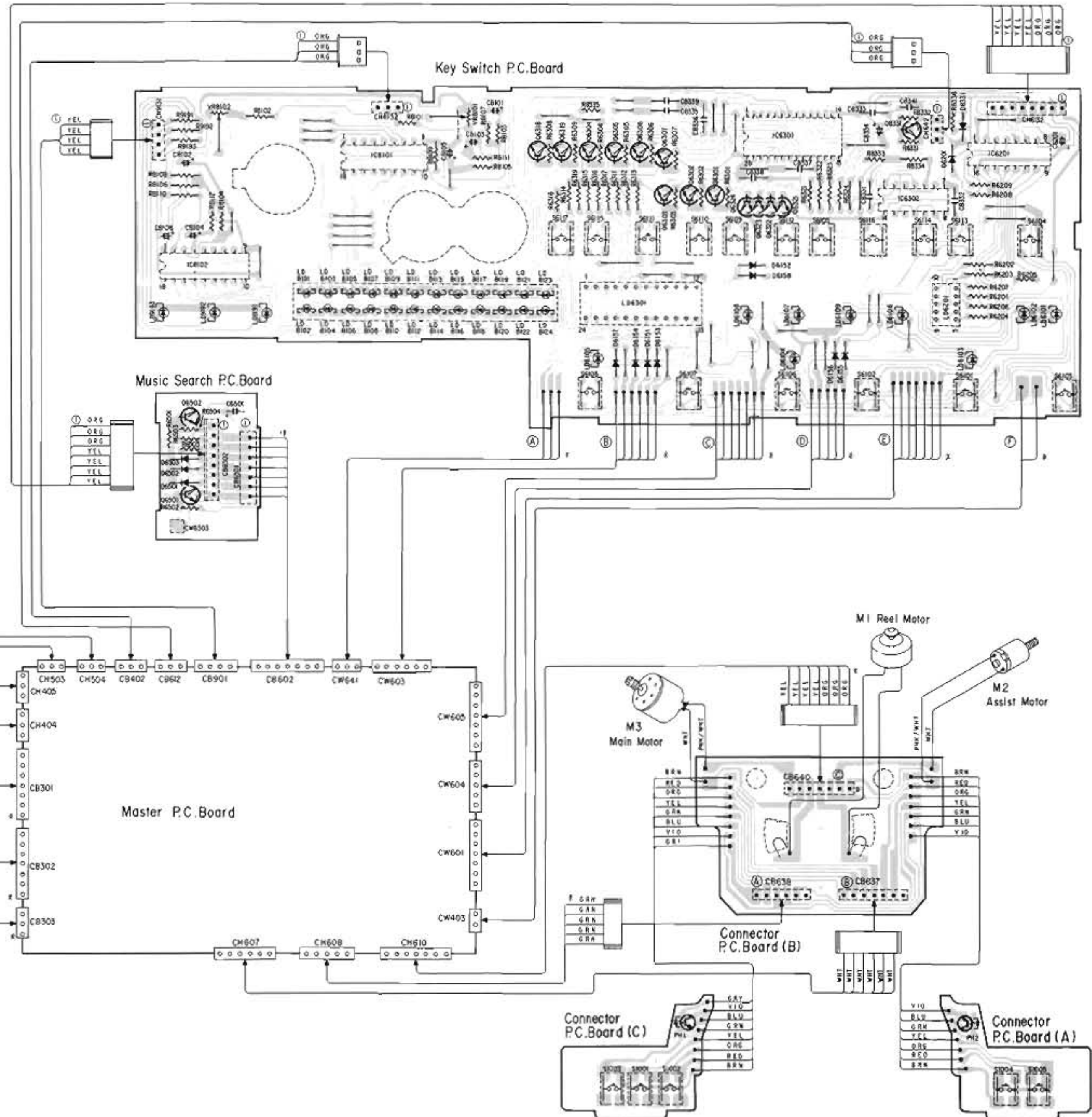
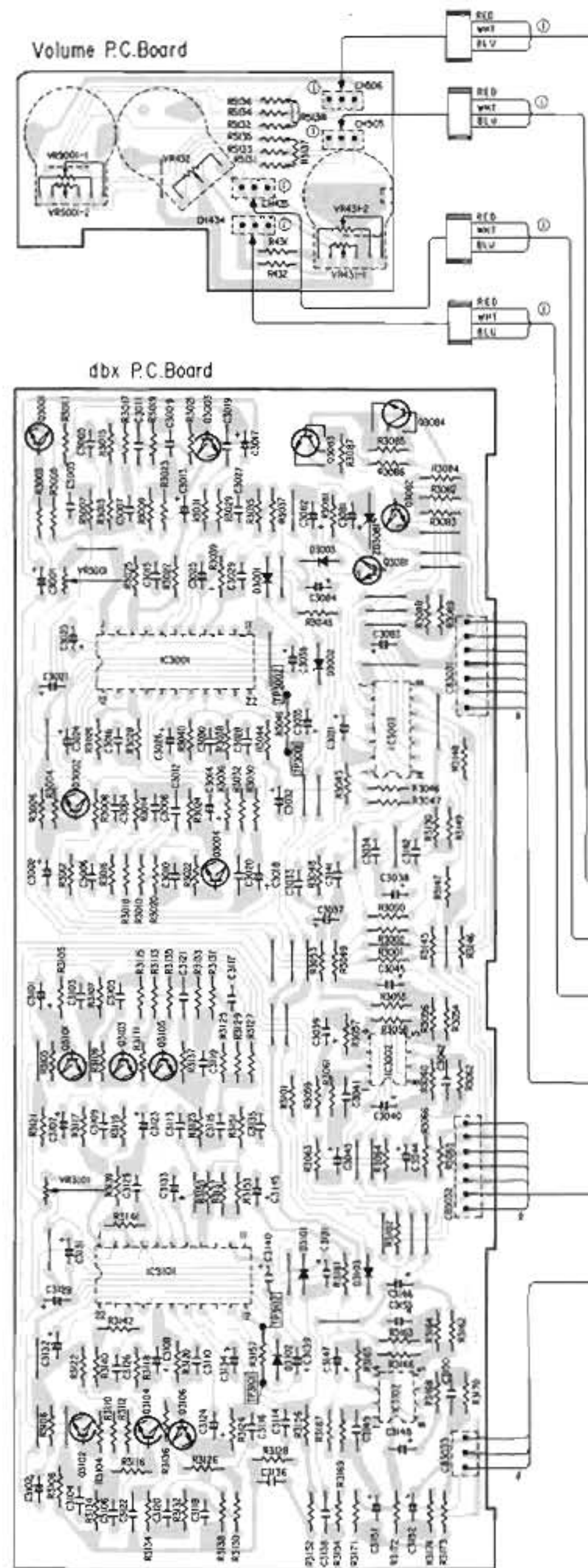

# Schematic Diagram (1/2)

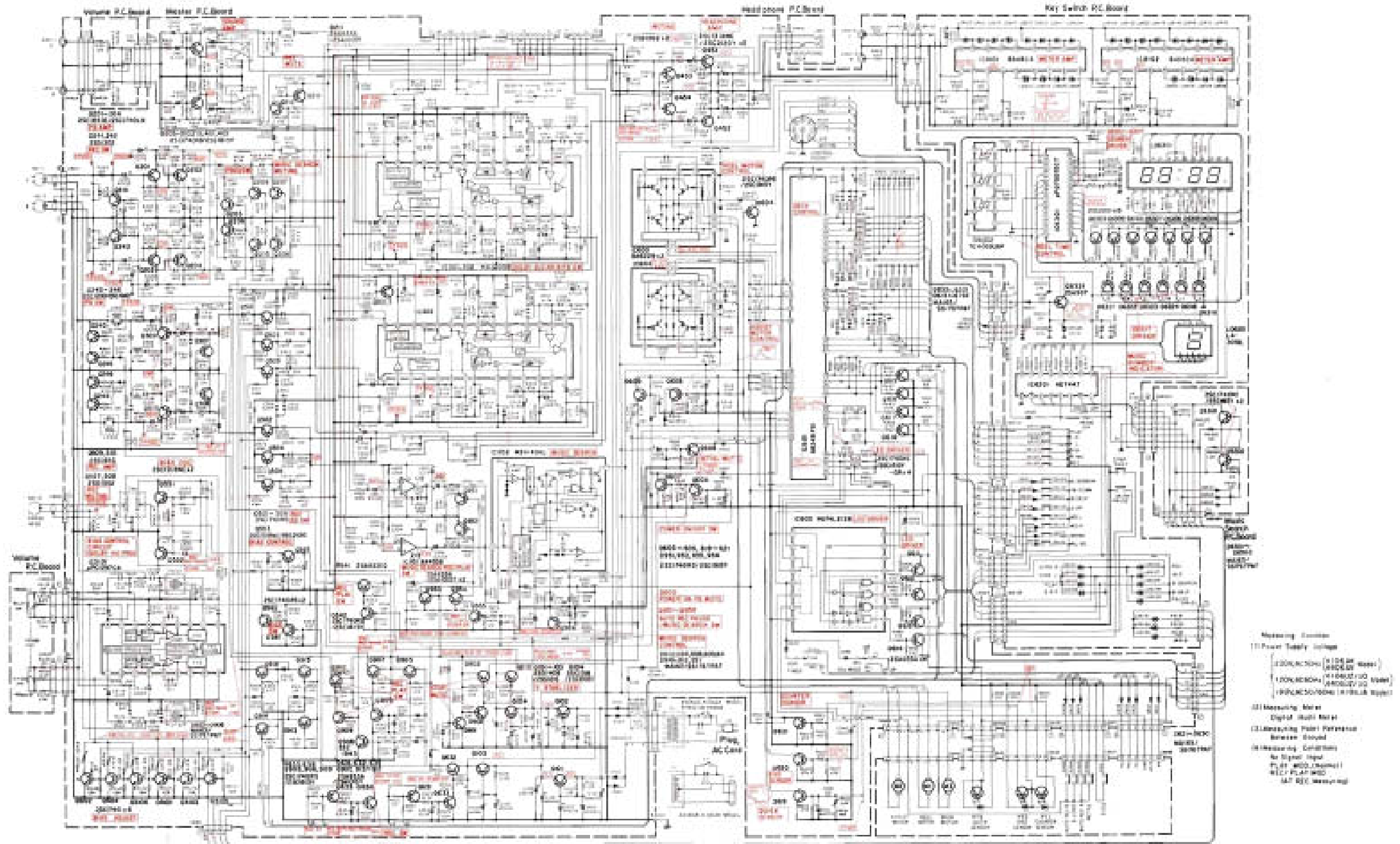

**NOTES:**  
 1. All resistance values are in ohms. K = 1,000  
 2. All capacitance values are in microfarads. M = 1,000,000

### Schematic Diagram (2/2)

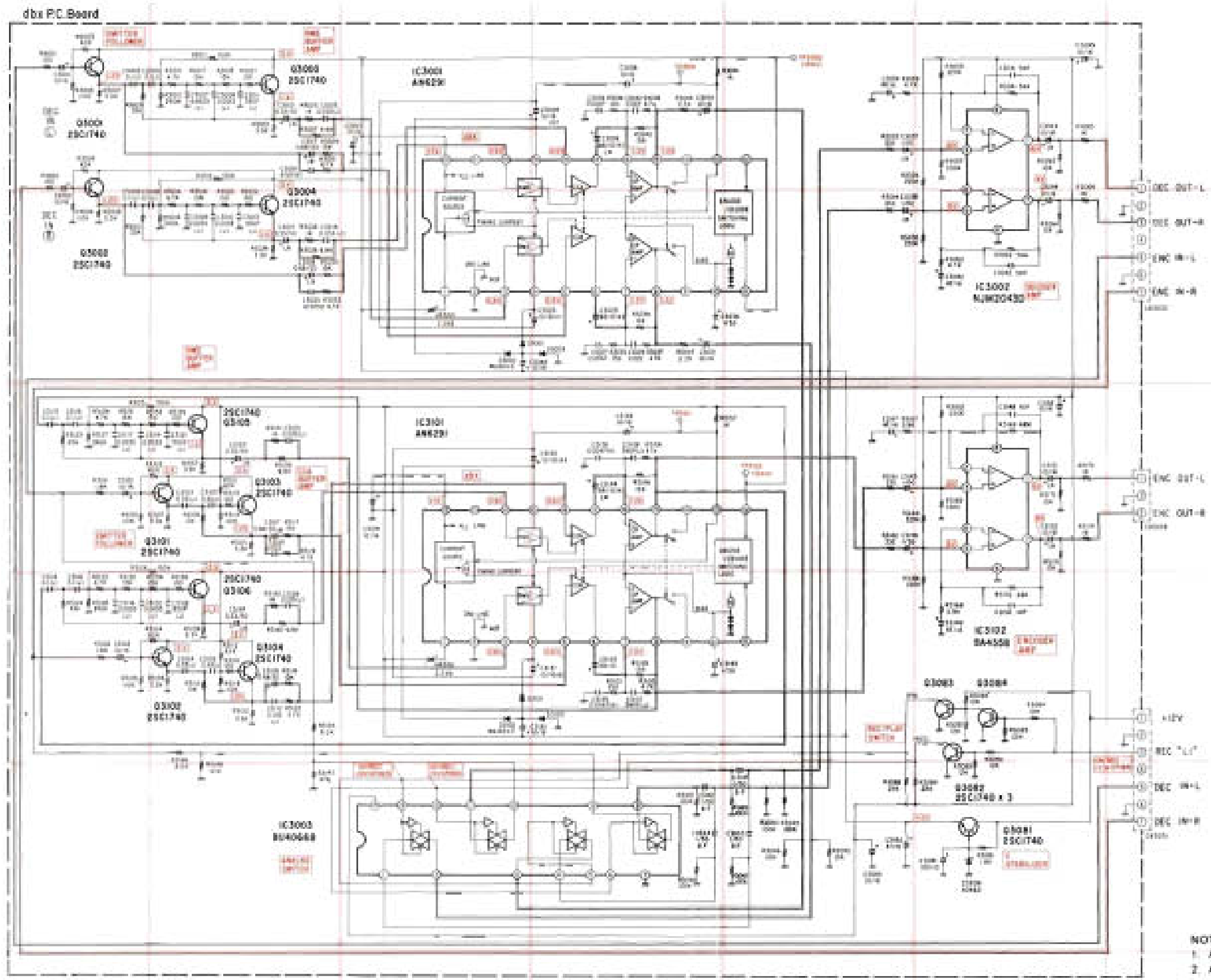

NOTES:  
 1. All resistance values are in ohms. K = 1,000.  
 2. All capacitance values are in microfarads.  $\mu$  = 1,000,000.



# Electrical Parts List

Resistors: Carbon resistors under 1/4 watts are not mentioned in the parts list, please confirm them by schematic diagram.  
 uF = microfarads, pF = picofarads

Symbol No.	Part No.	Description
<b>Master P.C. Board</b>		
<b>IC's</b>		
IC301	51T67728F01	HA12058
IC302	51T67728F01	HA12058
IC601	51T68248F01	68248F01
IC602	51T70538F01	HD74LS139
IC603	51T70536F01	BA6229
IC604	51T70536F01	BA6229
IC951	51T65380F01	8A4558
or	51S43471U02	μPC4558C
IC952	51T67915F01	M51143AL
IC5101	51T72929F01	μPC1297CA
<b>Transistors</b>		
Q103	48T58614F01	2SD1406
or	48T56031F01	2SD1266
Q104	48S40832F03	2SC1318NC
or	48T43015U01	2SC2120
Q201	48S47706F04	2SC1843
or	48T70535F01	2SC1740L
Q202	48S47706F04	2SC1843
or	48T70535F01	2SC1740L
Q203	48S47706F04	2SC1843
or	48T70535F01	2SC1740L
Q204	48S47706F04	2SC1843
or	48T70535F01	2SC1740L
Q205	48T55181F01	2SC1740
or	48S43525F05	2SC1815
Q206	48T55181F01	2SC1740
or	48S43525F05	2SC1815
Q207	48T55181F01	2SC1740
or	48S43525F05	2SC1815
Q208	48T55181F01	2SC1740
or	48S43525F05	2SC1815
Q209	48T55181F01	2SC1740
or	48S43525F05	2SC1815
Q210	48T55181F01	2SC1740
or	48S43525F05	2SC1815

Symbol No.	Part No.	Description
Q211	48T55349F01	2SA933A
or	48T51118F01	2SA1015
Q212	48T55181F01	2SC1740
or	48S43525F05	2SC1815
Q213	48T55349F01	2SA933A
or	48T51118F01	2SA1015
Q241	48T57305F01	2SD1302
Q242	48T57305F01	2SD1302
Q243	48S43394P01	2SC1890
or	48S41196U03	2SC1980
Q244	48S43394P01	2SC1890
or	48S41196U03	2SC1980
Q245	48S43394P01	2SC1890
or	48S41196U03	2SC1980
Q246	48S43394P01	2SC1890
or	48S41196U03	2SC1980
Q301	48T55181F01	2SC1740
or	48S43525F05	2SC1815
Q401	48T55181F01	2SC1740
or	48S43525F05	2SC1815
Q402	48T55181F01	2SC1740
or	48S43525F05	2SC1815
Q451	48S40832F03	2SC1318NC
or	48T43015U01	2SC2120
Q452	48S40832F03	2SC1318NC
or	48T43015U01	2SC2120
Q453	48T57305F01	2SD1302
Q454	48T57305F01	2SD1302
Q501	48T55181F01	2SC1740
or	48S43525F05	2SC1815
Q502	48T55181F01	2SC1740
or	48S43525F05	2SC1815
Q503	48T55181F01	2SC1740
or	48S43525F05	2SC1815
Q504	48T55181F01	2SC1740
or	48S43525F05	2SC1815
Q505	48T55181F01	2SC1740
or	48S43525F05	2SC1815
Q506	48T55181F01	2SC1740
or	48S43525F05	2SC1815
Q507	48T57305F01	2SD1302

Symbol No.	Part No.	Description
Q508	48T57305F01	2SD1302
Q509	48S47706F04	2SC1843
or	48T70535F01	2SC1740L
Q510	48S47706F04	2SC1843
or	48T70535F01	2SC1740L
Q541	48T55349F01	2SA933A
or	48T51118F01	2SA1015
Q542	48T55181F01	2SC1740
or	48S43525F05	2SC1815
Q551	48S40832F03	2SC1318NC
Q552	48S40832F03	2SC1318NC
Q553	48S40832F03	2SC1318NC
or	48T43015U01	2SC2120
Q580	48T55181F01	2SC1740
or	48S43525F05	2SC1815
Q581	48T55181F01	2SC1740
or	48S43525F05	2SC1815
Q604	48T55181F01	2SC1740
or	48S43525F05	2SC1815
Q605	48S43525F03	2SC1815
or	48T55181F01	2SC1740
Q606	48T55181F01	2SC1740
or	48S43525F05	2SC1815
Q607	48T55181F01	2SC1740
or	48S43525F05	2SC1815
Q608	48S43525F03	2SC1815
or	48T55181F01	2SC1740
Q609	48S43525F03	2SC1815
or	48T55181F01	2SC1740
Q611	48T55349F01	2SA933A
or	48T51118F01	2SA1015
Q612	48T55349F01	2SA933A
or	48T51118F01	2SA1015
Q613	48T55349F01	2SA933A
or	48T51118F01	2SA1015
Q614	48T55349F01	2SA933A
or	48T51118F01	2SA1015
Q615	48T55181F01	2SC1740
or	48S43525F05	2SC1815
Q616	48T55181F01	2SC1740
or	48S43525F05	2SC1815
Q617	48T55181F01	2SC1740
or	48S43525F05	2SC1815
Q618	48T55181F01	2SC1740
or	48S43525F05	2SC1815

Symbol No.	Part No.	Description
Q619	48T55181F01	2SC1740
or	48S43525F05	2SC1815
Q620	48T55181F01	2SC1740
or	48S43525F05	2SC1815
Q621	48T55181F01	2SC1740
or	48S43525F05	2SC1815
Q631	48T55349F01	2SA933A
or	48T51118F01	2SA1015
Q632	48T55349F01	2SA933A
or	48T51118F01	2SA1015
Q633	48T55181F01	2SC1740
or	48S43525F05	2SC1815
Q635	48T55349F01	2SA933A
or	48T51118F01	2SA1015
Q636	48T55181F01	2SC1740
or	48S43525F05	2SC1815
Q901	48T55181F01	2SC1740
or	48S43525F05	2SC1815
Q902	48T55181F01	2SC1740
or	48S43525F05	2SC1815
Q903	48T55349F01	2SA933A
or	48T51118F01	2SA1015
Q905	48T55181F01	2SC1740
or	48S43525F05	2SC1815
Q906	48T55181F01	2SC1740
or	48S43525F05	2SC1815
Q907	48T55349F01	2SA933A
or	48T51118F01	2SA1015
Q908	48S47706F04	2SC1843
or	48T70535F01	2SC1740L
Q909	48T55181F01	2SC1740
or	48S43525F05	2SC1815
Q910	48T42941U01	2SA921
Q913	48T55349F01	2SA933A
or	48T51118F01	2SA1015
Q914	48T55349F01	2SA933A
or	48T51118F01	2SA1015
Q915	48T55349F01	2SA933A
or	48T51118F01	2SA1015
Q916	48T55349F01	2SA933A
or	48T51118F01	2SA1015



Symbol No.	Part No.	Description
Q951 or Q952 or Q953 or	48T55181F01 48S43525F05 48T55181F01 48S43525F05 48T55349F01 48T51118F01	2SC1740 2SC1815 2SC1740 2SC1815 2SA933A 2SC1015
Q954 or Q955 or Q956 or	48T55349F01 48T51118F01 48T55181F01 48S43525F05 48T55181F01 48S43525F05	2SA933A 2SC1015 2SC1740 2SC1815 2SC1740 2SC1815
Q5101 or Q5102 or Q5103 or	48T55181F01 48S43525F05 48T55181F01 48S43525F05 48T55181F01 48S43525F05	2SC1740 2SC1815 2SC1740 2SC1815 2SC1740 2SC1815
Q5104 or Q5105 or Q5106 or	48T55181F01 48S43525F05 48T55181F01 48S43525F05 48T55181F01 48S43525F05	2SC1740 2SC1815 2SC1740 2SC1815 2SC1740 2SC1815
<b>Diodes</b>		
D101 D102 D103 D104 D106	48S40477U01 48S40477U01 48S40477U01 48S40477U01 48S40477U01	1N4003 1N4003 1N4003 1N4003 1N4003
D241 D242 D602 or D603 or	48T53429F01 48T53429F01 48T44813F01 48T58583F01 48T68764F03 48T51582F01	1SS81 1SS81 MA165TA SS176 1S2473 MA-150

Symbol No.	Part No.	Description
D604 or D607 or D608 or	48T44813F01 48T58583F01 48T68764F03 48T51582F01 48T44813F01 48T58583F01	MA165TA SS176 1S2473 MA-150 MA165TA SS176
D609 or D611 or D621 or	48T44813F01 48T58583F01 48T44813F01 48T58583F01 48T44813F01 48T58583F01	MA165TA SS176 MA165TA SS176 MA165TA SS176
D622 or D623 or D624 or	48T44813F01 48T58583F01 48T44813F01 48T58583F01 48T44813F01 48T58583F01	MA165TA SS176 MA165TA SS176 MA165TA SS176
D625 or D626 or D627 or	48T44813F01 48T58583F01 48T44813F01 48T58583F01 48T44813F01 48T58583F01	MA165TA SS176 MA165TA SS176 MA165TA SS176
D628 or D629 or D630 or	48T44813F01 48T58583F01 48T44813F01 48T58583F01 48T44813F01 48T58583F01	MA165TA SS176 MA165TA SS176 MA165TA SS176
D902 or D903 or D904 or	48T44813F01 48T58583F01 48T44813F01 48T58583F01 48T44813F01 48T58583F01	MA165TA SS176 MA165TA SS176 MA165TA SS176
D905 or D906 or D910 or	48T44813F01 48T58583F01 48T44813F01 48T58583F01 48T44813F01 48T58583F01	MA165TA SS176 MA165TA SS176 MA165TA SS176

Symbol No.	Part No.	Description
D911 or D912 or D951 or	48T44813F01 48T58583F01 48T44813F01 48T58583F01 48T44813F01 48T58583F01	MA165TA SS176 MA165TA SS176 MA165TA SS176
ZD101 or ZD102 or ZD103 or	48T52739F74 48T56372F54 48T52739F77 48T56372F58 48T52739F38 48T56372F27	HZ12B-2 Zener, RD13E-B2 Zener, HZ15-2 Zener, RD15E-B3 Zener, HZ6B-2 Zener, RD5.6E-B3
ZD104 or ZD105 or ZD301 or	48T52739F38 48T56372F27 48T52739F72 48T56372F53 48T52739F38 48T56372F27	Zener, HZ6B-2 Zener, RD5.6E-B3 Zener, HZ12A-3 Zener, RD13E-B1 Zener, HZ6B-2 Zener, RD5.6E-B3
ZD601 or ZD602 or ZD603 or	48T52739F40 48T56372F28 48T52739F39 48T56372F32 48T52739F04 48T56372F03	Zener, HZ6C-1 Zener, RD6.2E-B1 Zener, HZ6B-3 Zener, RD6.8E-B2 Zener, HZ2C-1 Zener, RD2.2E-C
<b>Inductors</b>		
L301 L302 L501 L502	24T47741F01 24T47741F01 24S41448F99 24S41448F99	36mH 36mH Radial 4700μH Radial 4700μH

Symbol No.	Part No.	Description
<b>Transformers</b>		
T501 T5101 T5102	24T70526F01 24T72930F01 24T72930F01	Coil, OSC HX HX
<b>Switches</b>		
S301 S601  S602	40T70531F01 40T70530F01  40T70530F01	Rotary, SBM4084N (NR) Rotary, SBM1023N (RIV MODE) Rotary, SBM1023N (TIMER)
<b>Jacks</b>		
J401 J601	09T70529F01 09T50261F01	Plate, Phone 4P (OSHI) Cont.
<b>Fuses</b>		
<input type="checkbox"/> F101 <input checked="" type="checkbox"/> F101	65T42077U18 65T42077U18	Semko T1.6A Semko T1.6A
<b>Filters</b>		
LF401 LF402 LF501 LF502 CF601	24T70527F01 24T70527F01 24T70528F01 24T70528F01 91T70534F01	MPX MPX BIAS (BLK) BIAS (BLK) Ceramic, CSA 4.00MG

K-406 model (■ : For European model only (AK))

K-106 model (□ : For European model only (AK))

Symbol No.	Part No.	Description
<b>Capacitors</b>		
C101	23S41198U77	Electrolytic 3300 $\mu$ F/25V
C102	23S41198U56	Electrolytic 470 $\mu$ F/16V
C103	23S41198U56	Electrolytic 470 $\mu$ F/16V
C104	23T68328F21	Electrolytic 2200 $\mu$ F/16V
C105	23S40657F52	Electrolytic 220 $\mu$ F/16V
C106	23T58450F05	Electrolytic 10000 $\mu$ F/16V
C107	23T68328F06	Electrolytic 470 $\mu$ F/10V
C108	23S40657F09	Electrolytic 220 $\mu$ F/10V
C109	23S40657F14	Electrolytic 100 $\mu$ F/16V
C110	23S40657F13	Electrolytic 47 $\mu$ F/16V
C111	23S40657F28	Electrolytic 1 $\mu$ F/50V
C201	08T55260F46	Ceramic 560 pF
C202	08T55260F46	Ceramic 560 pF
C203	23T42478F09	Electrolytic 4.7 $\mu$ F/25V
C204	23T42478F09	Electrolytic 4.7 $\mu$ F/25V
C205	23S40657F10	Electrolytic 10 $\mu$ F/16V
C206	23S40657F10	Electrolytic 10 $\mu$ F/16V
C207	08T55260F45	Ceramic 470 pF
C208	08T55260F45	Ceramic 470 pF
C209	08T55260F29	Ceramic 47 pF
C210	08T55260F29	Ceramic 47 pF
C211	23S40657F07	Electrolytic 47 $\mu$ F/10V
C212	23S40657F07	Electrolytic 47 $\mu$ F/10V
C213	23S40657F10	Electrolytic 10 $\mu$ F/16V
C214	23S40657F10	Electrolytic 10 $\mu$ F/16V
C215	08S40656F07	Mylar 3300 pF
C216	08S40656F07	Mylar 3300 pF
C217	08T55260F49	Ceramic 1000 pF
C218	08T55260F49	Ceramic 1000 pF
C219	08T57851F03	T.F. 0.015 $\mu$ F
C220	08T57851F03	T.F. 0.015 $\mu$ F
C221	08S40656F01	Mylar 1000 pF
C222	08S40656F01	Mylar 1000 pF
C223	23S40657F52	Electrolytic 220 $\mu$ F/16V
C241	23S40657F16	Electrolytic 4.7 $\mu$ F/25V
C242	08T55260F37	Ceramic 100 pF
C301	23T42478F05	Electrolytic 10 $\mu$ F/16V
C302	23T42478F05	Electrolytic 10 $\mu$ F/16V
C303	23T42478F24	Electrolytic 1 $\mu$ F/50V
C304	23T42478F24	Electrolytic 1 $\mu$ F/50V
C305	23S40657F09	Electrolytic 220 $\mu$ F/10V
C306	23S40657F09	Electrolytic 220 $\mu$ F/10V
C307	08T57851F07	T.F. 0.033 $\mu$ F
C308	08T57851F07	T.F. 0.033 $\mu$ F
C309	23S40657F16	Electrolytic 4.7 $\mu$ F/25V

Symbol No.	Part No.	Description
C310	23S40657F16	Electrolytic 4.7 $\mu$ F/25V
C311	08T57851F01	T.F. 0.01 $\mu$ F
C312	08T57851F01	T.F. 0.01 $\mu$ F
C313	08T57851F04	T.F. 0.018 $\mu$ F
C314	08T57851F04	T.F. 0.018 $\mu$ F
C315	23T42478F19	Electrolytic 0.15 $\mu$ F/50V
C316	23T42478F19	Electrolytic 0.15 $\mu$ F/50V
C317	23T42478F21	Electrolytic 0.33 $\mu$ F/50V
C318	23T42478F21	Electrolytic 0.33 $\mu$ F/50V
C319	23T42478F23	Electrolytic 0.68 $\mu$ F/50V
C320	23T42478F23	Electrolytic 0.68 $\mu$ F/50V
C321	23S40657F27	Electrolytic 0.47 $\mu$ F/50V
C322	23S40657F27	Electrolytic 0.47 $\mu$ F/50V
C323	23S40657F10	Electrolytic 10 $\mu$ F/16V
C324	23S40657F10	Electrolytic 10 $\mu$ F/16V
C325	08T55260F27	Ceramic 39 pF
C326	08T55260F27	Ceramic 39 pF
C327	08S40656F10	Mylar 5600 pF
C328	08S40656F10	Mylar 5600 pF
C329	23S40657F16	Electrolytic 4.7 $\mu$ F/25V
C330	23S40657F16	Electrolytic 4.7 $\mu$ F/25V
C331	08S40656F09	Mylar 4700 pF
C332	08S40656F09	Mylar 4700 pF
C333	08S40656F09	Mylar 4700 pF
C334	08S40656F09	Mylar 4700 pF
C335	08T57851F12	T.F. 0.082 $\mu$ F
C336	08T57851F12	T.F. 0.082 $\mu$ F
C337	23T42478F19	Electrolytic 0.15 $\mu$ F/50V
C338	23T42478F19	Electrolytic 0.15 $\mu$ F/50V
C339	23S40657F27	Electrolytic 0.47 $\mu$ F/50V
C340	23S40657F27	Electrolytic 0.47 $\mu$ F/50V
C341	08S40656F04	Mylar 1800 pF
C342	08S40656F04	Mylar 1800 pF
C343	23T42478F05	Electrolytic 10 $\mu$ F/16V
C344	23T42478F05	Electrolytic 10 $\mu$ F/16V
C361	23S40657F11	Electrolytic 22 $\mu$ F/16V
C362	23S40657F11	Electrolytic 22 $\mu$ F/16V
C363	23S40657F14	Electrolytic 100 $\mu$ F/16V
C364	23S40657F14	Electrolytic 100 $\mu$ F/16V
C365	23S40657F12	Electrolytic 33 $\mu$ F/16V
C401	23S40657F16	Electrolytic 4.7 $\mu$ F/25V
C402	23S40657F16	Electrolytic 4.7 $\mu$ F/25V
C403	23S40657F10	Electrolytic 10 $\mu$ F/16V
C404	23S40657F10	Electrolytic 10 $\mu$ F/16V
C405	23S40657F10	Electrolytic 10 $\mu$ F/16V

Symbol No.	Part No.	Description
C406	23S40657F10	Electrolytic 10 uF/16V
C407	08T55260F54	Ceramic 2200 pF
C408	08T55260F54	Ceramic 2200 pF
C409	23S40657F52	Electrolytic 220 uF/16V
C451	23S40657F28	Electrolytic 1 uF/50V
C452	23S40657F28	Electrolytic 1 uF/50V
C453	08T55260F33	Ceramic 68 pF
C454	08T55260F33	Ceramic 68 pF
C455	23S40657F09	Electrolytic 220 uF/10V
C456	23S40657F09	Electrolytic 220 uF/10V
C457	23S40657F10	Electrolytic 10 uF/16V
C458	23S40657F14	Electrolytic 100 uF/16V
C501	08T55260F63	Ceramic 1200 pF
C502	08T55260F63	Ceramic 1200 pF
C503	08T55260F49	Ceramic 1000 pF
C504	08T55260F49	Ceramic 1000 pF
C507	08T55260F63	Ceramic 1200 pF
C508	08T55260F63	Ceramic 1200 pF
C509	08T55260F45	Ceramic 470 pF
C510	08T55260F45	Ceramic 470 pF
C513	08T55260F48	Ceramic 820 pF
C514	08T55260F48	Ceramic 820 pF
C515	08T55260F64	Ceramic 3900 pF
C516	08T55260F64	Ceramic 3900 pF
C517	23T42478F09	Electrolytic 4.7 uF/25V
C518	23T42478F09	Electrolytic 4.7 uF/25V
C519	23S40657F16	Electrolytic 4.7 uF/25V
C520	23S40657F16	Electrolytic 4.7 uF/25V
C521	23S40657F10	Electrolytic 10 uF/16V
C522	23S40657F10	Electrolytic 10 uF/16V
C523	23T42478F09	Electrolytic 4.7 uF/25V
C524	23T42478F09	Electrolytic 4.7 uF/25V
C525	08T57851F03	T.F. 0.015 uF
C526	08T57851F03	T.F. 0.015 uF
C527	08T55260F43	Ceramic 330 pF
C528	08T55260F43	Ceramic 330 pF
C531	08T57851F17	T.F. 0.22 uF
C532	08T57851F17	T.F. 0.22 uF
C533	23S40657F52	Electrolytic 220 uF/16V
C535	23S40657F10	Electrolytic 10 uF/16V
C536	23S40657F10	Electrolytic 10 uF/16V
C551	08T52448F33	Polypropylene 6800 pF
C552	08T52448F25	Polypropylene 3300pF
C553	08T52448F25	Polypropylene 3300 pF
C554	08T52448F37	Polypropylene 0.01 uF

Symbol No.	Part No.	Description
C555	23S40657F10	Electrolytic 10 uF/16V
C556	23S40657F11	Electrolytic 22 uF/16V
C557	23S40657F13	Electrolytic 47 uF/16V
C561	08T52448F41	Polypropylene 0.015uF
C601	08T55260F61	Ceramic 0.01 uF
C602	23S40657F09	Electrolytic 220 uF/10V
C603	08S44505P61	Ceramic 0.01 uF
C604	08S44505P61	Ceramic 0.01 uF
C605	08S44505P61	Ceramic 0.01 uF
C606	08S44505P61	Ceramic 0.01 uF
C607	08S44505P61	Ceramic 0.01 uF
C608	08S44505P61	Ceramic 0.01 uF
C609	08S44505P61	Ceramic 0.01 uF
C610	08S44505P61	Ceramic 0.01 uF
C611	08T55260F54	Ceramic 2200 pF
C612	08T55260F54	Ceramic 2200 pF
C613	08T55260F54	Ceramic 2200 pF
C614	08T55260F54	Ceramic 2200 pF
C615	08T55260F54	Ceramic 2200 pF
C616	08T55260F54	Ceramic 2200 pF
C617	08T55260F54	Ceramic 2200 pF
C618	23S40657F27	Electrolytic 0.47 uF/50V
C619	08T55260F24	Ceramic 30 pF
C620	08T55260F24	Ceramic 30 pF
C621	23S40657F10	Electrolytic 10 uF/16V
C623	08S44505P61	Ceramic 0.01 uF
C624	23T42477F18	Electrolytic (B.P) 2.2 uF/50V
C625	08S44505P61	Ceramic 0.01 uF
C626	23S40657F10	Electrolytic 10 uF/16V
C628	23S40657F16	Electrolytic 4.7 uF/25V
C629	23S40657F07	Electrolytic 47 uF/10V
C631	23S40657F27	Electrolytic 0.47 uF/50V
C633	23S40657F11	Electrolytic 22 uF/16V
C635	23S40657F11	Electrolytic 22 uF/16V
C640	23S41198U12	Electrolytic 10 uF/50V
C901	23S40657F27	Electrolytic 0.47 uF/50V
C902	23S40657F10	Electrolytic 10 uF/16V
C903	23S40657F16	Electrolytic 4.7 uF/25V
C951	23S40657F16	Electrolytic 4.7 uF/25V
C952	23S40657F16	Electrolytic 4.7 uF/25V
C953	08T55260F29	Ceramic 47 pF
C955	23S40657F16	Electrolytic 4.7 uF/25V
C956	23S40657F16	Electrolytic 4.7 uF/25V
C957	23S40657F10	Electrolytic 10 uF/16V
C958	23S40657F13	Electrolytic 47 uF/16V
C959	23S40657F13	Electrolytic 47 uF/16V

Symbol No.	Part No.	Description
C960	23S40657F28	Electrolytic 1 $\mu$ F/50V
C961	23T42478F18	Electrolytic 0.1 $\mu$ F/50V
C962	08T57851F09	T.F. 0.047 $\mu$ F
C963	23S40657F10	Electrolytic 10 $\mu$ F/16V
C5101	08T55260F13	Ceramic 10 pF
C5103	08T57851F09	T.F. 0.047 $\mu$ F
C5104	08T57851F09	T.F. 0.047 $\mu$ F
C5105	08T55260F44	Ceramic 390 pF
C5106	08T55260F44	Ceramic 390 pF
C5107	08T57851F13	T.F. 0.1 $\mu$ F
C5108	08T57851F13	T.F. 0.1 $\mu$ F
C5109	08T55260F46	Ceramic 560 pF
C5110	08T55260F46	Ceramic 560 pF
C5111	08T57851F05	T.F. 0.022 $\mu$ F
C5112	08T57851F05	T.F. 0.022 $\mu$ F
C5113	08T57851F01	T.F. 0.01 $\mu$ F
C5114	08T57851F01	T.F. 0.01 $\mu$ F
C5115	08T55260F45	Ceramic 470 pF
C5116	08T55260F45	Ceramic 470 pF
C5117	23S40657F10	Electrolytic 10 $\mu$ F/16V
C5118	23S40657F10	Electrolytic 10 $\mu$ F/16V
<b>Resistors</b>		
R603	51T52333F05	09A 103K-10KX8
R652	06T55179F17	Metal Film 10 ohm 2W
or	06T00007L17	Metal Oxide Film 10 ohm 2W
R654	06T55179F17	Metal Film 10 ohm 2W
or	06T00007L17	Metal Oxide Film 10 ohm 2W
VR201	18T52946F15	Variable 22K ohm
VR202	18T52946F15	Variable 22K ohm
VR501	18T52946F17	Variable 47K ohm
VR502	18T52946F17	Variable 47K ohm
VR602	18T52946F11	Variable 4.7K ohm
VR5101	18T52946F15	Variable 22K ohm
VR5102	18T52946F15	Variable 22K ohm
VR5103	18T52946F11	Variable 4.7K ohm
VR5104	18T52946F11	Variable 4.7K ohm
VR5105	18T52946F09	Variable 2.2K ohm
VR5106	18T52946F09	Variable 2.2K ohm

Symbol No.	Part No.	Description
<b>dbx P.C. Board</b>		
<b>IC's</b>		
IC3001	51T56606F01	AN6291
IC3002	51T52153F01	NJM2043D
IC3003	51T68999F01	BU4066B
or	51T47739F01	TC4066BP
IC3101	51T56606F01	AN6291
IC3102	51T65380F01	8A4558
or	51S43471U02	$\mu$ PC4558C
<b>Transistors</b>		
Q3001	48T55181F01	2SC1740
or	48S43525F05	2SC1815
Q3002	48T55181F01	2SC1740
or	48S43525F05	2SC1815
Q3003	48T55181F01	2SC1740
or	48S43525F05	2SC1815
Q3004	48T55181F01	2SC1740
or	48S43525F05	2SC1815
Q3081	48T55181F01	2SC1740
or	48S43525F05	2SC1815
Q3082	48T55181F01	2SC1740
or	48S43525F05	2SC1815
Q3083	48T55181F01	2SC1740
or	48S43525F05	2SC1815
Q3084	48T55181F01	2SC1740
or	48S43525F05	2SC1815
Q3101	48T55181F01	2SC1740
or	48S43525F05	2SC1815
Q3102	48T55181F01	2SC1740
or	48S43525F05	2SC1815
Q3103	48T55181F01	2SC1740
or	48S43525F05	2SC1815
Q3104	48T55181F01	2SC1740
or	48S43525F05	2SC1815
Q3105	48T55181F01	2SC1740
or	48S43525F05	2SC1815
Q3106	48T55181F01	2SC1740
or	48S43525F05	2SC1815



Symbol No.	Part No.	Description
<b>Diodes</b>		
D3001	48T44813F01	MA165TA
D3002	48T44813F01	MA165TA
D3003	48T44813F01	MA165TA
D3101	48T44813F01	MA165TA
D3102	48T44813F01	MA165TA
D3103	48T44813F01	MA165TA
ZD3081 or	48T52739F17 48T56372F12	Zener, HZ4A-2 Zener, RD3.6E-B1
<b>Capacitors</b>		
C3001	23S40657F10	Electrolytic 10 uF/16V
C3002	23S40657F10	Electrolytic 10 uF/16V
C3003	08T57851F13	T.F. 0.1 uF
C3004	08T57851F13	T.F. 0.1 uF
C3005	08T57851F13	T.F. 0.1 uF
C3006	08T57851F13	T.F. 0.1 uF
C3007	08S40656F07	Mylar 3300 pF
C3008	08S40656F07	Mylar 3300 pF
C3009	08S40656F07	Mylar 3300 pF
C3010	08S40656F07	Mylar 3300 pF
C3011	08T55260F43	Ceramic 330 pF
C3012	08T55260F43	Ceramic 330 pF
C3013	23T42478F21	Electrolytic 0.33 uF/50V
C3014	23T42478F21	Electrolytic 0.33 uF/50V
C3015	08T57851F07	T.F. 0.033 uF
C3016	08T57851F07	T.F. 0.033 uF
C3017	23T42478F23	Electrolytic 0.68 uF/50V
C3018	23T42478F23	Electrolytic 0.68 uF/50V
C3019	08T55260F45	Ceramic 470 pF
C3020	08T55260F45	Ceramic 470 pF
C3021	23S40657F10	Electrolytic 10 uF/16V
C3023	23T71541F02	Electrolytic 10 uF/16V
C3024	23T71541F02	Electrolytic 10 uF/16V
C3025	23T71541F01	Electrolytic 68 uF/10V
C3026	23T71541F01	Electrolytic 68 uF/10V

Symbol No.	Part No.	Description
C3027	08S40656F09	Mylar 4700 pF
C3028	08S40656F09	Mylar 4700 pF
C3029	08T57851F05	T.F. 0.022 uF
C3030	08T57851F05	T.F. 0.022 uF
C3031	23S40657F10	Electrolytic 10 uF/16V
C3032	23S40657F10	Electrolytic 10 uF/16V
C3033	23T42477F16	Electrolytic (B.P.) 1 uF/50V
C3034	23T42477F16	Electrolytic (B.P.) 1 uF/50V
C3035	23S40657F10	Electrolytic 10 uF/16V
C3036	23S40657F28	Electrolytic 1 uF/50V
C3037	23T42478F24	Electrolytic 1 uF/50V
C3038	23T42478F24	Electrolytic 1 uF/50V
C3039	23S40657F13	Electrolytic 47 uF/16V
C3040	23S40657F13	Electrolytic 47 uF/16V
C3041	08T55260F31	Ceramic 56 pF
C3042	08T55260F31	Ceramic 56 pF
C3043	23T42478F05	Electrolytic 10 uF/16V
C3044	23T42478F05	Electrolytic 10 uF/16V
C3045	23S40657F10	Electrolytic 10 uF/16V
C3081	23S40657F08	Electrolytic 100 uF/10V
C3082	23S40657F13	Electrolytic 47 uF/16V
C3083	23S40657F10	Electrolytic 10 uF/16V
C3084	23S40657F10	Electrolytic 10 uF/16V
C3101	23S40657F10	Electrolytic 10 uF/16V
C3102	23S40657F10	Electrolytic 10 uF/16V
C3103	08T57851F19	T.F. 0.33 uF
C3104	08T57851F19	T.F. 0.33 uF
C3105	08T57851F19	T.F. 0.33 uF
C3106	08T57851F19	T.F. 0.33 uF
C3107	23T42478F23	Electrolytic 0.68 uF/50V
C3108	23T42478F23	Electrolytic 0.68 uF/50V
C3109	08T57851F05	T.F. 0.022 uF
C3110	08T57851F05	T.F. 0.022 uF
C3113	08T57851F13	T.F. 0.1 uF
C3114	08T57851F13	T.F. 0.1 uF
C3115	08T57851F13	T.F. 0.1 uF
C3116	08T57851F13	T.F. 0.1 uF
C3117	08S40656F07	Mylar 3300 pF
C3118	08S40656F07	Mylar 3300 pF
C3119	08S40656F07	Mylar 3300 pF
C3120	08S40656F07	Mylar 3300 pF
C3121	08T55260F43	Ceramic 330 pF
C3122	08T55260F43	Ceramic 330 pF
C3123	23T42478F21	Electrolytic 0.33 uF/50V
C3124	23T42478F21	Electrolytic 0.33 uF/50V

Symbol No.	Part No.	Description	
C3125	08T57851F07	T.F.	0.033 $\mu$ F
C3126	08T57851F07	T.F.	0.033 $\mu$ F
C3129	23S40657F10	Electrolytic	10 $\mu$ F/16V
C3131	23T71541F02	Electrolytic	10 $\mu$ F/16V
C3132	23T71541F02	Electrolytic	10 $\mu$ F/16V
C3133	23T71541F01	Electrolytic	68 $\mu$ F/10V
C3134	23T71541F01	Electrolytic	68 $\mu$ F/10V
C3135	08S40656F09	Mylar	4700 pF
C3136	08S40656F09	Mylar	4700 pF
C3137	08T55260F44	Ceramic	390 pF
C3138	08T55260F44	Ceramic	390 pF
C3139	23S40657F10	Electrolytic	10 $\mu$ F/16V
C3140	23S40657F28	Electrolytic	1 $\mu$ F/50V
C3141	23T42477F16	Electrolytic (B.P)	1 $\mu$ F/50V
C3142	23T42477F16	Electrolytic (B.P)	1 $\mu$ F/50V
C3145	23S40657F28	Electrolytic	1 $\mu$ F/50V
C3146	23S40657F28	Electrolytic	1 $\mu$ F/50V
C3147	23S40657F13	Electrolytic	47 $\mu$ F/16V
C3148	23S40657F13	Electrolytic	47 $\mu$ F/16V
C3149	08T55260F13	Ceramic	10 pF
C3150	08T55260F13	Ceramic	10 pF
C3151	23T42478F05	Electrolytic	10 $\mu$ F/16V
C3152	23T42478F05	Electrolytic	10 $\mu$ F/16V
C3153	23S40657F10	Electrolytic	10 $\mu$ F/16V
C3181	23S40657F10	Electrolytic	10 $\mu$ F/16V
<b>Resistors</b>			
VR3001	18T52946F09	Variable	2.2K ohm
VR3101	18T52946F09	Variable	2.2K ohm
<b>Music Search P.C. Board</b>			
<b>Transistors</b>			
Q6501 or Q6502 or	48T55181F01 48S43525F05 48T55181F01 48S43525F05	2SC1740 2SC1815 2SC1740 2SC1815	

Symbol No.	Part No.	Description	
<b>Diodes</b>			
D6501 or D6502 or D6503 or	48T44813F01 48T58583F01 48T44813F01 48T58583F01 48T44813F01 48T58583F01	MA165TA SS176 MA165TA SS176 MA165TA SS176	
<b>Capacitor</b>			
C6501	23S40657F07	Electrolytic	47 $\mu$ F/10V
<b>Key Switch P.C. Board</b>			
<b>IC's</b>			
IC6201 IC6301 IC6302 IC8101 IC8102	51T72908F01 51T72030F01 51T50832F01 51T60489F01 51T60489F01	HD7447AP $\mu$ PD7507 SCT-210 TC4069UBP BA682A BA682A	
<b>Transistors</b>			
Q6301 Q6302 Q6303 Q6304 Q6305	48T63082F04 48T63082F04 48T63082F04 48T63082F04 48T63082F04	2SC2021M 2SC2021M 2SC2021M 2SC2021M 2SC2021M	
Q6306 Q6307 Q6318 Q6319 Q6321	48T63082F04 48T63082F04 48T63082F04 48T63082F04 48T63082F04	2SC2021M 2SC2021M 2SC2021M 2SC2021M 2SC2021M	
Q6322 Q6323 Q6324 Q8331	48T63082F04 48T63082F04 48T63082F04 48T63086F03	2SC2021M 2SC2021M 2SC2021M 2SA937M	

Symbol No.	Part No.	Description
<b>Diodes/LED's</b>		
D6151 or D6152 or D6153 or	48T44813F01 48T58583F01 48T44813F01 48T58583F01 48T44813F01 48T58583F01	MA165TA SS176 MA165TA SS176 MA165TA SS176
D6154 or	48T44813F01 48T58583F01	MA165TA SS176
D6155 or	48T44813F01 48T58583F01	MA165TA SS176
D6156 or	48T44813F01 48T58583F01	MA165TA SS176
D6157 or	48T44813F01 48T58583F01	MA165TA SS176
D6158 or	48T44813F01 48T58583F01	MA165TA SS176
D6201 or	48T44813F01 48T58583F01	MA165TA SS176
D8331 or	48T44813F01 48T58583F01	MA165TA SS176
LD6101	48T72233F01	LED, SLR-54MG3M (GRN) (DIRA.R)
LD6102	48T72233F01	LED, SLR-54MG3M (GRN) (DIRB.L)
LD6103	48T72233F01	LED, SLR-54MG3M (GRN) (PLAY)
LD6104	48T66616F02	LED, SLR-54VR3 (RED) (REC)
LD6105	48T70949F01	LED, SLR54DC3F (ORG) (PAUSE)
LD6106	48T73874F01	LED, SLR-40DC3F (ORG) (ARP)
LD6107	48T73874F01	LED, SLR-40DC3F (ORG) (INS)
LD6108	48T73874F01	LED, SLR-40DC3F (ORG) (BSK)
LD6109	48T73874F01	LED, SLR-40DC3F (ORG) (BSE)
LD6201	48T72907F01	LED, LA-301VB1
LD6301	48T72906F01	LED, LC-204VB7
LD8101	48T73875F01	LED, SLR-40VC3F (RED) (LEVEL METER)
LD8102	48T73875F01	LED, SLR-40VC3F (RED) (LEVEL METER)

Symbol No.	Part No.	Description
LD8103	48T73875F01	LED, SLR-40VC3F (RED) (LEVEL METER)
LD8104	48T73875F01	LED, SLR-40VC3F (RED) (LEVEL METER)
LD8105	48T73875F01	LED, SLR-40VC3F (RED) (LEVEL METER)
LD8106	48T73875F01	LED, SLR-40VC3F (RED) (LEVEL METER)
LD8107	48T73875F01	LED, SLR-40VC3F (RED) (LEVEL METER)
LD8108	48T73875F01	LED, SLR-40VC3F (RED) (LEVEL METER)
LD8109	48T73875F01	LED, SLR-40VC3F (RED) (LEVEL METER)
LD8110	48T73875F01	LED, SLR-40VC3F (RED) (LEVEL METER)
LD8111	48T73874F01	LED, SLR-40DC3F (ORG) (LEVEL METER)
LD8112	48T73874F01	LED, SLR-40DC3F (ORG) (LEVEL METER)
LD8113	48T73874F01	LED, SLR-40DC3F (ORG) (LEVEL METER)
LD8114	48T73874F01	LED, SLR-40DC3F (ORG) (LEVEL METER)
LD8115	48T73874F01	LED, SLR-40DC3F (ORG) (LEVEL METER)
LD8116	48T73874F01	LED, SLR-40DC3F (ORG) (LEVEL METER)
LD8117	48T73874F01	LED, SLR-40DC3F (ORG) (LEVEL METER)
LD8118	48T73874F01	LED, SLR-40DC3F (ORG) (LEVEL METER)
LD8119	48T73874F01	LED, SLR-40DC3F (ORG) (LEVEL METER)
LD8120	48T73874F01	LED, SLR-40DC3F (ORG) (LEVEL METER)
LD8121	48T73874F01	LED, SLR-40DC3F (ORG) (LEVEL METER)
LD8122	48T73874F01	LED, SLR-40DC3F (ORG) (LEVEL METER)
LD8123	48T73874F01	LED, SLR-40DC3F (ORG) (LEVEL METER)
LD8124	48T73874F01	LED, SLR-40DC3F (ORG) (LEVEL METER)
LD9191	48T70949F01	LED, SLR54DC3F (ORG)
LD9192	48T70949F01	LED, SLR54DC3F (ORG)
LD9193	48T70949F01	LED, SLR54DC3F (ORG)



Symbol No.	Part No.	Description	
<b>Switches</b>			
S6101	40T70532F01	Tact (KHH, GRAY) (PLAY)	
S6102	40T70532F01	Tact (KHH, GRAY) (F.R)	
S6103	40T70532F01	Tact (KHH, GRAY) (FL)	
S6104	40T70532F01	Tact (KHH, GRAY) (DIR)	
S6105	40T70532F01	Tact (KHH, GRAY) (R. MU)	
S6106	40T70532F01	Tact (KHH, GRAY) (REC)	
S6107	40T70532F01	Tact (KHH, GRAY) (STOP)	
S6108	40T70532F01	Tact (KHH, GRAY) (PAUSE)	
S6109	40T70532F01	Tact (KHH, GRAY) (B.SE)	
S6110	40T70532F01	Tact (KHH, GRAY) (INS)	
S6111	40T70532F01	Tact (KHH, GRAY) (BSK)	
S6112	40T70532F01	Tact (KHH, GRAY) (ARP)	
S6113	40T70532F01	Tact (KHH, GRAY) (MSL)	
S6114	40T70532F01	Tact (KHH, GRAY) (MSR)	
S6115	40T70532F01	Tact (KHH, GRAY) (RESET)	
S6116	40T70532F01	Tact (KHH, GRAY) (MU, NO)	
S6117	40T70532F01	Tact (KHH, GRAY) (MEMO)	
<b>Capacitors</b>			
C6201	23T57422F09	Electrolytic	10 uF/16V
C8101	23T57422F06	Electrolytic	2.2 uF/50V
C8102	23T57422F06	Electrolytic	2.2 uF/50V
C8103	23T57422F09	Electrolytic	10 uF/16V
C8104	23T57422F09	Electrolytic	10 uF/16V
C8105	23T57422F09	Electrolytic	10 uF/16V
C8106	23T57422F09	Electrolytic	10 uF/16V
C8331	08T55260F29	Ceramic	47 pF
C8332	08T55260F61	Ceramic	0.01 uF
C8333	08T55260F61	Ceramic	0.01 uF
C8334	23T57422F09	Electrolytic	10 uF/16V
C8335	08T55260F49	Ceramic	1000 pF
C8336	08T55260F49	Ceramic	1000 pF
C8337	08T55260F49	Ceramic	1000 pF
C8338	08T55260F49	Ceramic	1000 pF
C8339	08T55260F49	Ceramic	1000 pF
<b>Resistors</b>			
VR8101	18T52946F17	Variable	47K ohm
VR8102	18T52946F17	Variable	47K ohm

Symbol No.	Part No.	Description	
<b>Terminal P.C. Board</b>			
<b>Photo Transistors and LED/Switches</b>			
PT1	AZ12G-00	NJL5141E	
PT2	AZ12G-00	NJL5141E	
S1001	UE13K-11	Switch, Tact KHN10902 (CrO <sub>2</sub> )	
S1002	UE13K-11	Switch, Tact KHN10902 (METAL)	
S1003	UE13K-11	Switch, Tact KHN10902 (AUTO REC A)	
S1004	UE13K-11	Switch, Tact KHN10902 (C. LOAD)	
S1005	UE13K-11	Switch, Tact KHN10902 (AUTO REC B)	
<b>Volume P.C. Board</b>			
VR431	18T70525F01	Volume, Rotary K162P 50K ohm	
VR432	18T70524F01	Volume, Rotary K161M 100K ohm	
VR 5001	18T72927F01	Volume, Rotary K162Y 10K ohm	
<b>Miscellaneous</b>			
C1	08T57437F09	Capacitor, Ceramic 0.01uF	
HD1	F257-055	Assembly, Turning Head	
□ J1	09T60095F01	AC Socket	
■ J1	09T60095F01	AC Socket	
J451	09T66672F01	Jack, Headphone (SLIM)	
M1	F064-133	Assembly, Reel Motor	
M2	F064-136	Assembly, Assist Motor	
M3	F064-141	Assembly, Main Motor	
● P1	28T40916U01	Plug, AC Cord	
▲ P1	28T41871U01	Plug, AC Cord	
PT3	F258-036	Assembly, Sensor	
Q101	48T58614F01	Transistor, 2SD1406	
or	48T56031F01	Transistor, 2SD1266	
Q102	48T58614F01	Transistor, 2SD1406	
or	48T56031F01	Transistor, 2SD1266	
S1	40T56950F01	Switch, Power SDLIP (ASF)	
● T1	25T72928F01	Trans, Power	
□ T1	25T72999F01	Trans, Power	
■ T1	25T72999F01	Trans, Power	
▲ T1	25T73052F01	Trans, Power	

K-406 model | ●: For North American model only (UZ), ■: For European model only (AK), ★: For Canadian model only (UO)|  
 K-106 model | □: For North American model only (UZ), □: For European model only (AK), ☆: For Canadian model only (UO),  
 ▲: For Japanese model only (JA))

Others: Common

## Parts List by Specific Countries

Symbol No.	Description	POWER SOURCE								
		K-406			K-106					
		UZ ●	AK ■	UQ ★	UZ ○	AK □	UQ ☆			
		120V North America	220V Europe	120V Canada	120V North America	220V Europe	120V Canada			
JA ▲						100V Japan				
F101	Fuse	Not Used	65T42077U18	Not Used	65T42077U18	Not Used	65T42077U18	Not Used	65T42077U18	Not Used
J1	AC Socket	Not Used	09T60095F01	Not Used	09T60095F01	Not Used	09T60095F01	Not Used	09T60095F01	Not Used
P1	Plug, AC Cord	28T40916U01	Not Used	28T40916U01	28T40916U01	Not Used	28T40916U01	28T40916U01	28T40916U01	28T41871U01
T1	Trans. Power	25T72928F01	25T72999F01	25T72928F01	25T72928F01	25T72999F01	25T72928F01	25T72928F01	25T72928F01	25T73052F01
1	Cover, Rear	15D70547F08	15D70547F12	15D70547F08	15D70547F13	15D70547F11	15D70547F13	15D70547F13	15D70547F13	15D70547F10
5	Stopper, Cord	43B41625J01	Not Used	43B41625J01	43B41625J01	Not Used	43B41625J01	43B41625J01	43B41625J01	43B41625J01
16	Knob, Function	36B70552F01	36B70552F01	36B70552F01	36B70552F02	36B70552F02	36B70552F02	36B70552F02	36B70552F02	36B70552F02
19	Assembly Logic Knob	01V71200F44	01V71200F44	01V71200F44	01V71800F61	01V71800F61	01V71800F61	01V71800F61	01V71800F61	01V71800F61
26	Knob, Power	36A56639F02	36A56639F02	36A56639F02	36A67330F01	36A67330F01	36A67330F01	36A67330F01	36A67330F01	36A67330F01
27	Assembly Door Cover	01V71200F48	01V71200F48	01V71200F48	01V71800F58	01V71800F58	01V71800F58	01V71800F58	01V71800F58	01V71800F58
28	Knob, Rotary	36A70560F02	36A70560F02	36A70560F02	36A70620F01	36A70620F01	36A70620F01	36A70620F01	36A70620F01	36A70620F01
29	Knob, Control	36A56005F02	36A56005F02	36A56005F02	36A56005F03	36A56005F03	36A56005F03	36A56005F03	36A56005F03	36A56005F03
30	Knob, Control	36A55234F02	36A55234F02	36A55234F02	36A55234F03	36A55234F03	36A55234F03	36A55234F03	36A55234F03	36A55234F03
31	Knob, Eject	36A45474F07	36A45474F07	36A45474F07	36A45474F04	36A45474F04	36A45474F04	36A45474F04	36A45474F04	36A45474F04
32	Assembly, Front Panel	01V73500F60	01V73500F60	01V73500F60	01V73700F08	01V73700F08	01V73700F08	01V73700F08	01V73700F08	01V73600F29
33	Cover, Top	15C70608F01	15C70608F01	15C70608F01	15C70608F03	15C70608F03	15C70608F03	15C70608F03	15C70608F03	15C70608F03
37	Frame, Side Panel	07B67093F02	07B67093F02	07B67093F02	07B70554F01	07B70554F01	07B70554F01	07B70554F01	07B70554F01	07B70554F01
38	Frame, Side Panel	07B67093F03	07B67093F03	07B67093F03	07B70555F01	07B70554F01	07B70555F01	07B70555F01	07B70555F01	07B70555F01
45	Shield, Key Switch	26A74138F01	26A74138F01	26A74138F01	Not Used	Not Used	Not Used	Not Used	Not Used	Not Used
46	Lug	29A41814G01	29A41814G01	29A41814G01	29A41814G01	29A41814G01	29A41814G01	29A41814G01	29A41814G01	29A41814G01
50	Screw, Bind	Not Used	03S43997F76	Not Used	Not Used	Not Used	03S43997F76	Not Used	Not Used	Not Used
51	Holder, Fuse	Not Used	09T45548F01	Not Used	Not Used	Not Used	09T45548F01	Not Used	Not Used	Not Used
52	Label, Fuse	Not Used	54B62266F19	Not Used	Not Used	54B62266F19	54B62266F19	Not Used	Not Used	Not Used
101-1	Owners, Manual	68P70001F81	68P73333F08	68P73333F08	68P73333F72	68P73333F01	68P73333F01	68P73333F01	68P73333F01	68P73333F02
101-3	Cord, Set	Not Used	30T60805F01	Not Used	Not Used	30T60805F01	30T60805F01	Not Used	Not Used	Not Used
103	Carton, Packing	56S71001F25	56S71001F25	56S71001F25	56S71001F10	56S71001F29	56S71001F29	56S71001F29	56S71001F29	56S71001F28

# Exploded View (Cabinet)

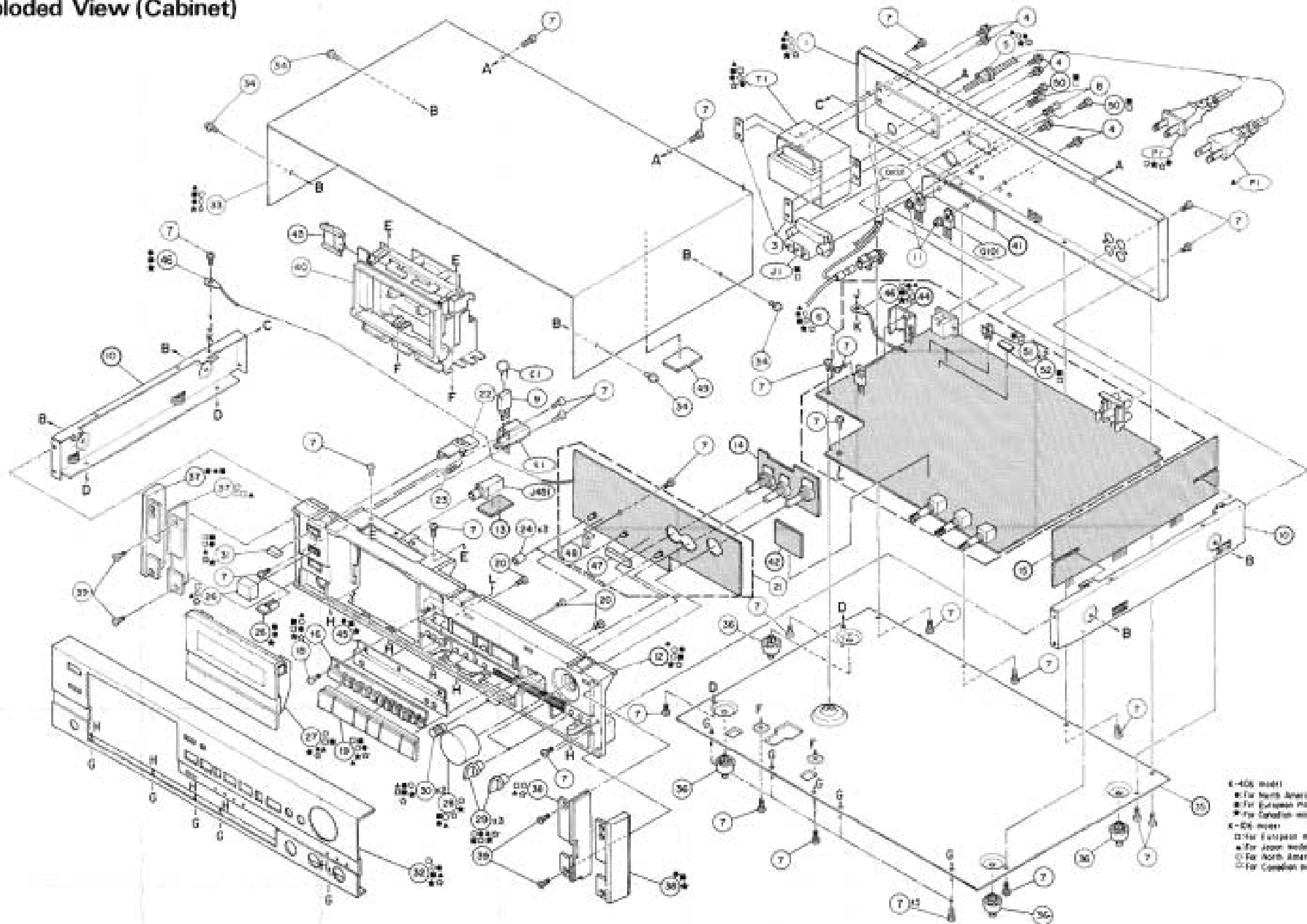

- 408 model
- For North American model only (1121)
- For European model only (1A)
- For Canadian model only (102)
- 409 model
- For European model only (100)
- For Japan model only (1A)
- For North American model only (1121)
- For Canadian model only (102)

### Exploded View (Cassette Deck)

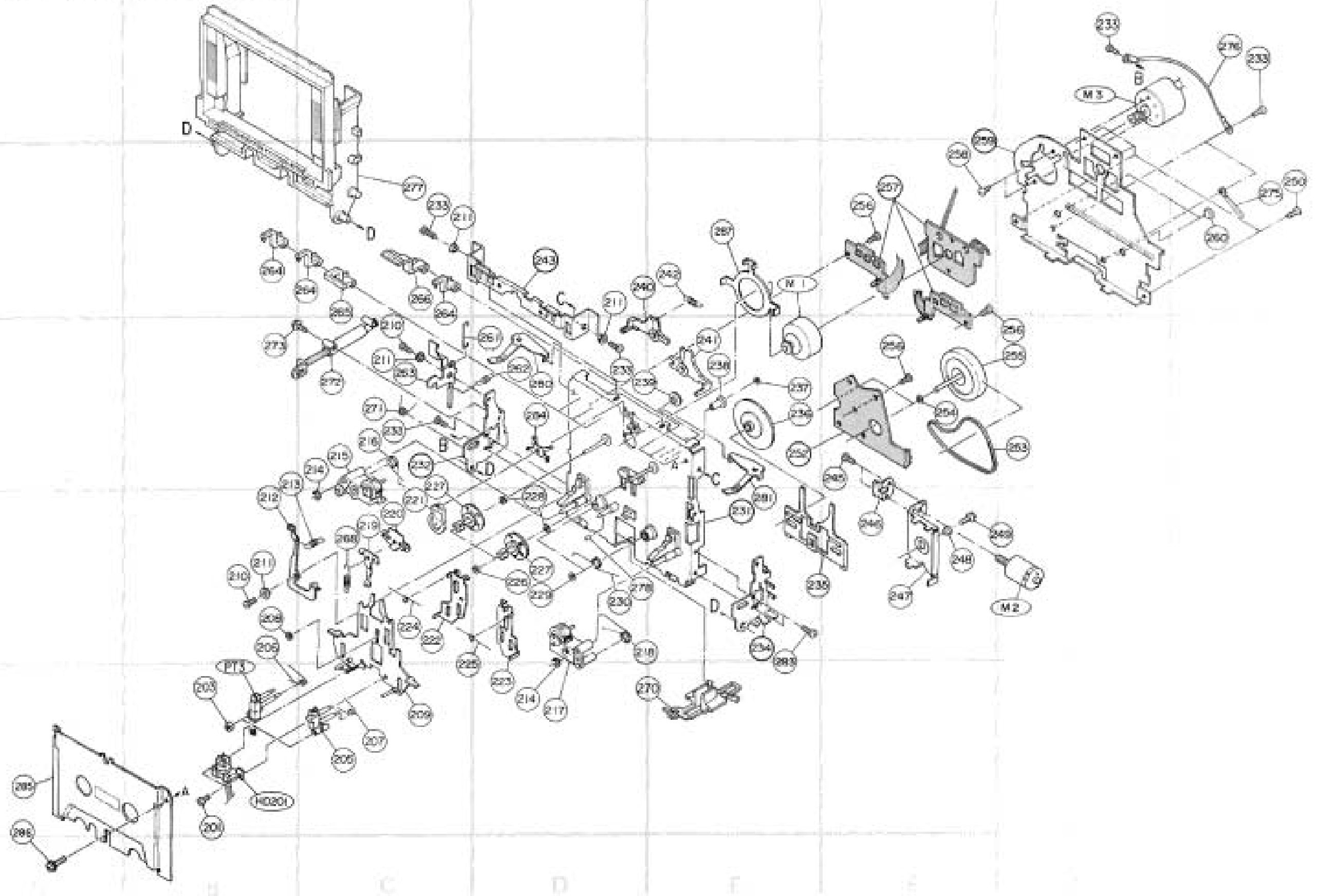

# Cabinet Assembly Parts List

Symbol	No.	Index	Part No.	Description
●	1	1-E	15D70547F08	Cover, Rear
□	1		15D70547F11	Cover, Rear
■	1		15D70547F12	Cover, Rear
▲	1		15D70547F10	Cover, Rear
○	1		15D70547F13	Cover, Rear
◇	1		15D70547F13	Cover, Rear
★	1		15D70547F08	Cover, Rear
	3		07A70548F01	Support, Trans Nut
	4		03C40121T16	Screw, W/Double Washer (M3 x 12)
●	5	1-F	43B41625J01	Stopper, Cord
▲	5		43B41625J01	Stopper, Cord
★	5		43B41625J01	Stopper, Cord
○	5		43B41625J01	Stopper, Cord
☆	5		43B41625J01	Stopper, Cord
	7		03S71031F04	Screw, Bind (M3 x 8)
	8	1-G	05B41635J02	Rivet, Push
	9	3-D	43T53136F01	Bush, Cap. TP150-301
	11	2-F	02B47353F02	Nut, Hex Flange (M3)
●	16	4-B	36B70552F01	Knob, Function
□	16		36B70552F02	Knob, Function
■	16		36B70552F01	Knob, Function
▲	16		36B70552F02	Knob, Function
☆	16		36B70552F02	Knob, Function
★	16		36B70552F01	Knob, Function
○	16		36B70552F02	Knob, Function
	18	4-B	03S71031F02	Screw, Bind (M2.6 x 8)
●	19	5-C	01V71200F44	Assembly, Logic Knob
□	19		01V71800F61	Assembly, Logic Knob
■	19		01V71200F44	Assembly, Logic Knob
▲	19		01V71800F61	Assembly, Logic Knob
○	19		01V71800F61	Assembly, Logic Knob
★	19		01V71200F44	Assembly, Logic Knob
☆	19		01V71800F61	Assembly, Logic Knob
	20	4-B	03S71031F01	Screw, Bind (M2 x 6)
	21	4-E	01V73500F38	Assembly, Key Switch P.C. Board
	22	3-C	45A70553F01	Lever, Eject
	23	3-C	41A45559F03	Spring, Eject
	24	4-D	43A61758F01	Spacer, Lamp 1011-UL
●	26		36A56639F02	Knob, Power 1171-2
□	26		36A67330F01	Knob, Power 1171-2

Symbol	No.	Index	Part No.	Description
■	26		36A56639F02	Knob, Power 1171-2
▲	26		36A67330F01	Knob, Power 1171-2
★	26		36A56639F02	Knob, Power 1171-2
○	26		36A67330F01	Knob, Power 1171-2
☆	26		36A67330F01	Knob, Power 1171-2
●	27	5-B	01V71200F48	Assembly, Door Cover
□	27		01V71800F58	Assembly, Door Cover
■	27		01V71200F48	Assembly, Door Cover
▲	27		01V71800F58	Assembly, Door Cover
★	27		01V71200F48	Assembly, Door Cover
○	27		01V71800F58	Assembly, Door Cover
☆	27		01V71800F58	Assembly, Door Cover
●	28	5-C	36A70560F02	Knob, Rotary (MASTER VOLUME)
□	28		36A70620F01	Knob, Rotary (MASTER VOLUME)
■	28		36A70560F02	Knob, Rotary (MASTER VOLUME)
▲	28		36A70620F01	Knob, Rotary (MASTER VOLUME)
★	28		36A70560F02	Knob, Rotary (MASTER VOLUME)
☆	28		36A70620F01	Knob, Rotary (MASTER VOLUME)
○	28		36A70620F01	Knob, Rotary (MASTER VOLUME)
●	29	5-C	36A56005F02	Knob, Control (TIMER, REVERSE MODE, DOLBY NR)
□	29		36A56005F03	Knob, Control (TIMER, REVERSE MODE, DOLBY NR)
■	29		36A56005F02	Knob, Control (TIMER, REVERSE MODE, DOLBY NR)
▲	29		36A56005F03	Knob, Control (TIMER, REVERSE MODE, DOLBY NR)
★	29		36A56005F02	Knob, Control (TIMER, REVERSE MODE, DOLBY NR)
○	29		36A56005F03	Knob, Control (TIMER, REVERSE MODE, DOLBY NR)
◇	29		36A56005F03	Knob, Control (TIMER, REVERSE MODE, DOLBY NR)
●	30	5-C	36A55234F02	Knob, Control (BIAS FINE, BALANCE)
□	30		36A55234F03	Knob, Control (BIAS FINE, BALANCE)
■	30		36A55234F02	Knob, Control (BIAS FINE, BALANCE)

K-406 model | ●: For North American model only (UZ), ■: For European model only (AK), ★: For Canadian model only (UQ)

K-106 model | ○: For North American model only (UZ), □: For European model only (AK), ☆: For Canadian model only (UQ),

▲: For Japanese model only (JA)

Others: Common

Symbol No.	Index	Part No.	Description	
▲ 30		36A55234F03	Knob, Control (BIAS FINE, BALANCE)	
★ 30		36A55234F02	Knob, Control (BIAS FINE, BALANCE)	
○ 30		36A55234F03	Knob, Control (BIAS FINE, BALANCE)	
☆ 30		36A55234F03	Knob, Control (BIAS FINE, BALANCE)	
● 31	4-B	36A45474F07	Knob, Eject	
□ 31		36A45474F04	Knob, Eject	
■ 31		36A45474F07	Knob, Eject	
▲ 31		36A45474F04	Knob, Eject	
★ 31		36A45474F07	Knob, Eject	
○ 31		36A45474F04	Knob, Eject	
☆ 31		36A45474F04	Knob, Eject	
● 32	5-C	01V73500F60	Assembly, Front Pnael	
□ 32		01V73700F08	Assembly, Front Panel	
■ 32		01V73500F60	Assembly, Front Panel	
▲ 32		01V73600F29	Assembly, Front Panel	
★ 32		01V73500F60	Assembly, Front Panel	
○ 32		01V73700F08	Assembly, Front Panel	
☆ 32		01V73700F08	Assembly, Front Panel	
● 33	2-B	15C70608F01	Cover, Top	
□ 33		15C70608F03	Cover, Top	
■ 33		15C70608F01	Cover, Top	
▲ 33		15C70608F03	Cover, Top	
★ 33		15C70608F01	Cover, Top	
○ 33		15C70608F03	Cover, Top	
☆ 33		15C70608F03	Cover, Top	
		34	03S40036U01	Screw, W/Washer (M4 x 8)
		36	75A60070F01	Pad, Rubber
● 37	3-B	07B67093F02	Frame, Side Panel (L)	
□ 37		07B70554F01	Frame, Side Panel (L)	
■ 37		07B67093F02	Frame, Side Panel (L)	
▲ 37		07B70554F01	Frame, Side Panel (L)	
★ 37		07B67093F02	Frame, Side Panel (L)	
○ 37		07B70554F01	Frame, Side Panel (L)	
☆ 37		07B70554F01	Frame, Side Panel (L)	
● 38	5-D	07B67093F03	Frame, Side Panel (R)	
□ 38		07B70555F01	Frame, Side Panel (R)	
■ 38		07B67093F03	Frame, Side Panel (R)	
▲ 38		07B70555F01	Frame, Side Panel (R)	
★ 38		07B67093F03	Frame, Side Panel (R)	
○ 38		07B70555F01	Frame, Side Panel (R)	
☆ 38		07B70555F01	Frame, Side Panel (R)	

Symbol No.	Index	Part No.	Description
39		03S71031F06	Screw, Countersink (M3 x 12)
40	2-B	81T72829F01	Deck, Cassette (FW87E020)
43	2-B	43A70564F01	Bar, Eject
● 45	4-C	26A74138F01	Shield, Key Switch
■ 45		26A74138F01	Shield, Key Switch
★ 45		26A74138F01	Shield, Key Switch
● 46	2-F	29A41814G01	Lug
□ 46		29A41814G01	Lug
■ 46		29A41814G01	Lug
★ 46		29A41814G01	Lug
○ 46		29A41814G01	Lug
☆ 46		29A41814G01	Lug
47	4-D	75S72374F22	Cushion, Rubber (36.8 x 7.2)
48	4-D	75S72374F23	Cushion, Rubber (11.8 x 4.6)
49		75S72374F11	Cushion, Rubber (60.0 x 25.0)
□ 50		03S43997F76	Screw, Bind (M3 x 6)
■ 50		03S43997F76	Screw, Bind (M3 x 6)
□ 51	2-F	09T45548F01	Holder, Fuse
■ 51		09T45548F01	Holder, Fuse
□ 52	3-G	54B62266F19	Label, Fuse T1.6A
■ 52		54B62266F19	Label, Fuse T1.6A

K-406 model | ● : For North American model only (UZ), ■ : For European model only (AK), ★ : For Canadian model only (UQ)  
 K-106 model | ○ : For North American model only (UZ), □ : For European model only (AK), ☆ : For Canadian model only (UQ)  
 ▲ : For Japanese model only (JA)

Others: Common

# Cassette Deck Assembly Parts List

Symbol No.	Index	Part No.	Description	Symbol No.	Index	Part No.	Description
201	5-B	FG114-23	Screw, W/Washer (M2 x 5)	248	4-F	FK20M-14	Bracket, Spring
203	5-B	FD30C-21	Nut, Adjustment	249	4-F	UG13V-11	Screw, Tapping (M2.6 x 8)
205	5-C	FD27R-22	Tape, Guide	250	2-H	UG12H-14	Screw, Pan (M2.6 x 8)
206	4-B	FK20A-13	Spring, Adjustment (L)	253	3-G	FE15E-12	Belt, Main
207	5-C	FK20B-13	Spring, Adjustment (R)	254	3-F	FJ111-30	Washer, Polyslider (M2.6)
208	4-B	MM113-11	Ball, Steel	255	3-G	FR18B-13	Assembly, F/W FHR
209	5-C	F012-097	Assembly, Plate Head	256		UG12H-11	Screw, Pan (M2 x 6)
210		KG194-12	Screw, Pan (M3 x 6)	258	2-F	UG11S-11	Screw, W/Washer (M2.6 x 3.5)
211		FM296-11	Spacer	260	2-H	FM177-22	Spacer, Flywheel
212	4-B	FC33V-25	Arm, Eject Prevention (L)	261	3-D	FK20N-11	Link, Connection
213	3-B	FK20D-12	Spring, Eject Prevention	262	3-D	FK20C-13	Spring, Eject Arm
214	3-C	KG111-19	Ring, E	263	3-C	FC33W-21	Arm, Eject (L)
215	3-C	F014-086	Assembly, Pinch Roller	264		F244-013	Assembly, Rec. Detector
216	3-C	FK21A-11	Spring, Pinch Roller (L)	265	2-C	F246-015	Assembly, Metal Detector
217	5-D	F014-085	Assembly, Pinch Roller	266	2-C	F245-017	Assembly, Pack Detector
218	4-D	FK20Y-11	Spring, Pinch Roller (R)	268	4-C	FK20T-15	Spring, CR Slide
219	4-C	FC33F-21	Spring, Pull	270	5-D	FD29V-21	Lead, Holder
220	4-C	FD28C-22	Plate C/R Slide	271	3-C	FK21G-11	Spring, Door
221	4-C	F017-043	Assembly, Idler	272	3-C	FP472-11	Assembly, Dumper
222	4-C	FC34R-12	Base, Slide (L)	273	3-B	UG12R-11	Screw, Cup (M2.04 x 12)
223	5-D	FC35D-12	Base, Slide (R)	275	2-H	F139-013	Lug
224	4-C	FK20F-17	Spring, SB (L)	276	1-H	WG29L-01	Lead, Earth
225	4-C	FK20G-14	Spring, SB (R)	277	2-C	FD31L-11	Assembly, Frame Door
226	4-D	FJ111-17	Washer, Polyslider (M1.7)	278	4-D	UT11R-11	Reflector
227	4-D	F123-037	Assembly, Take Up Reel	280	3-D	FC35F-11	Spring, Cassette Holder (L)
228	4-D	UJ12P-11	Washer, Polyslider (M2.1)	281	4-E	FC35E-11	Spring, Cassette Hoder (R)
229	4-D	FJ141-11	Washer, Oil Shield (M2.5)	283	4-E	KG194-46	Screw, Tap Tite (M3 x 4)
230	4-D	FK20H-15	Spring, H, B	284	3-D	FC39P-11	Spring, Brake
233		KG189-11	Screw, Pan (M3 x 5)	285	5-A	F184-047	Assembly, Dust Cover
235	4-E	FD27K-21	Slide, Changer	286	5-A	UG12T-11	Screw, Cup (M2.6 x 12)
236	3-E	F061-019	Assembly, Gear	287	2-E	FU35U-21	Plate, Earth
237	3-E	FJ123-14	Luminer				
238	3-E	FD27M-21	Gear, Worm				
239	3-D	FD27L-21	Gear, Idler				
240	2-D	FD29N-23	Lever, Brake (L)				
241	3-E	FD29P-22	Lever, Brake (R)				
242	2-E	FK20R-12	Spring, Brake				
245	3-F	FG141-20	Screw W/Washer (M2 x 3.5)				
246	4-F	FC33M-22	Spring, Thrust				
247	4-F	FC33D-21	Bracket, Assist Motor (R)				

# Packing Method View

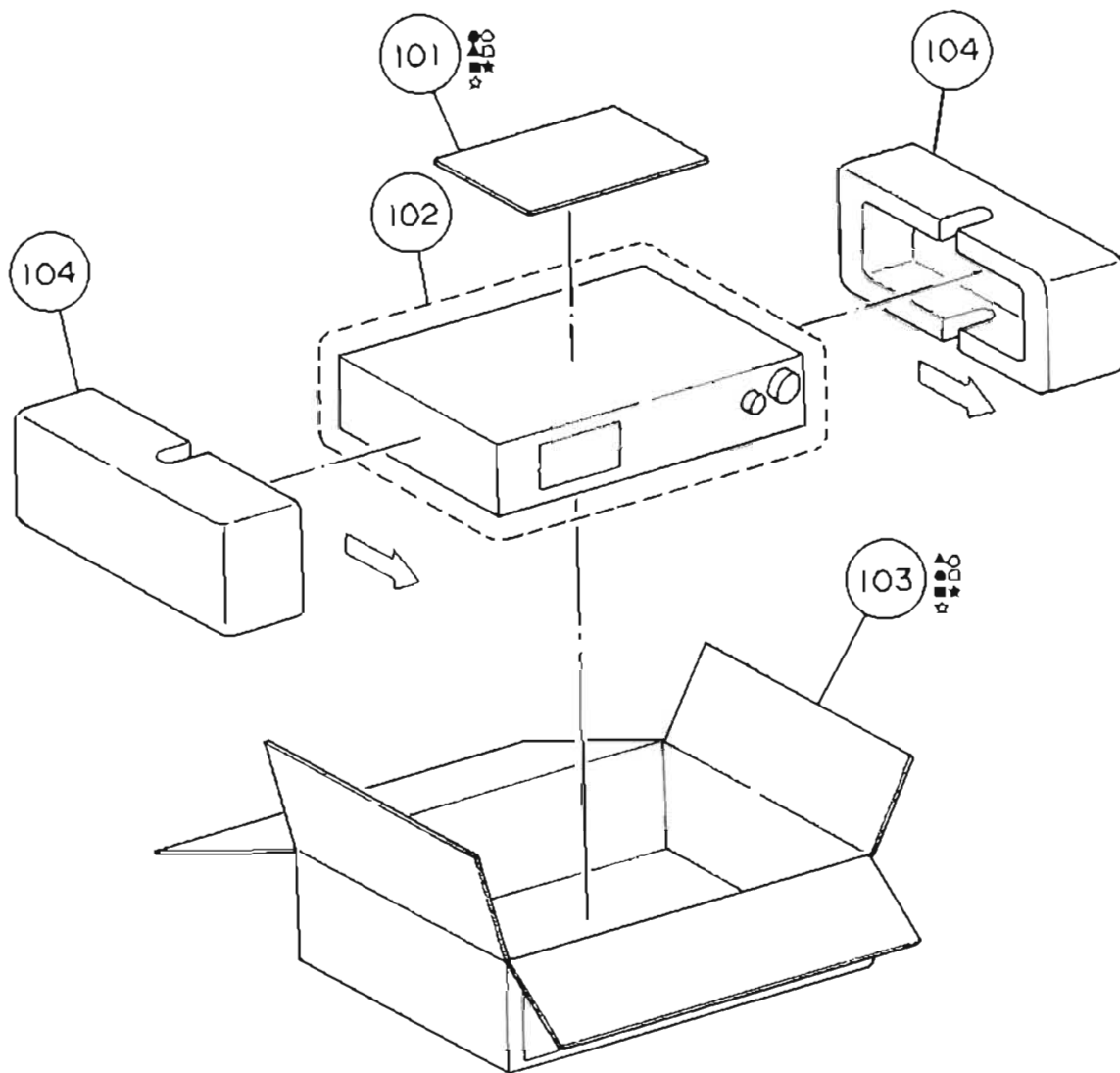

K-406 model | ● : For North American model only (UZ), ■ : For European model only (AK), ★ : For Canadian model only (UQ)  
K-106 model | ○ : For North American model only (UZ), □ : For European model only (AK), ☆ : For Canadian model only (UD),  
▲ : For Japanese model only (JA)  
Others: Common



# Packing Assembly Parts List

Symbol No.	Part No.	Description
●	101-1 68P70001F81	Owners Manual
□	101-1 68P73333F01	Owners Manual
■	101-1 68P73333F08	Owners Manual
▲	101-1 68P73333F02	Owners Manual
○	101-1 68P73333F72	Owners Manual
☆	101-1 68P73333F01	Owners Manual
★	101-1 68P73333F08	Owners Manual
	101-2 28T70621F01	Plug, Output Cord
■	101-3 30T60805F01	Cord, Set Semko
□	101-3 30T60805F01	Cord, Set Semko
	102 56B40230G23	Sack, Polyethylene
●	103 56S71001F25	Carton, Packing (Individual)
□	103 56S71001F29	Carton, Packing (Individual)
■	103 56S71001F25	Carton, Packing (Individual)
▲	103 56S71001F28	Carton, Packing (Individual)
★	103 56S71001F25	Carton, Packing (Individual)
○	103 56S71001F10	Carton, Packing (Individual)
☆	103 56S71001F29	Carton, Packing (Individual)
	104 56C70363F01	Tray, Packing

Symbol No.	Part No.	Description
<b>Labels</b>		
●	54B42124G08	Serial No. (Rear Cover, Carton Packing)
▲	54B42124G08	Serial No. (Rear Cover, Carton Packing)
●	54B42124G02	Date (Bottom Cover)
●	54A57559F01	Side Caution (Side Chassis (R))
●	54A57559F02	Bottom Caution (Bottom Cover)
■	54B44257U09	Volt (220V)
●	54B44257U06	Volt (120V)
★	54B44257F08	Volt (120V)
☆	54B44257U08	Volt (120V)
○	54B57610F34	LUX, Serial No.

K-406 model | ● : For North American model only (UZ), ■ : For European model only (AK), ★ : For Canadian model only (UO)|  
 K-106 model | ○ : For North American model only (UZ), □ : For European model only (AK), ☆ : For Canadian model only (UO).  
 ▲ : For Japanese model only (JA)

Others: Common

# Semi-Conductor Lead Identifications

HA12058: IC301, IC302

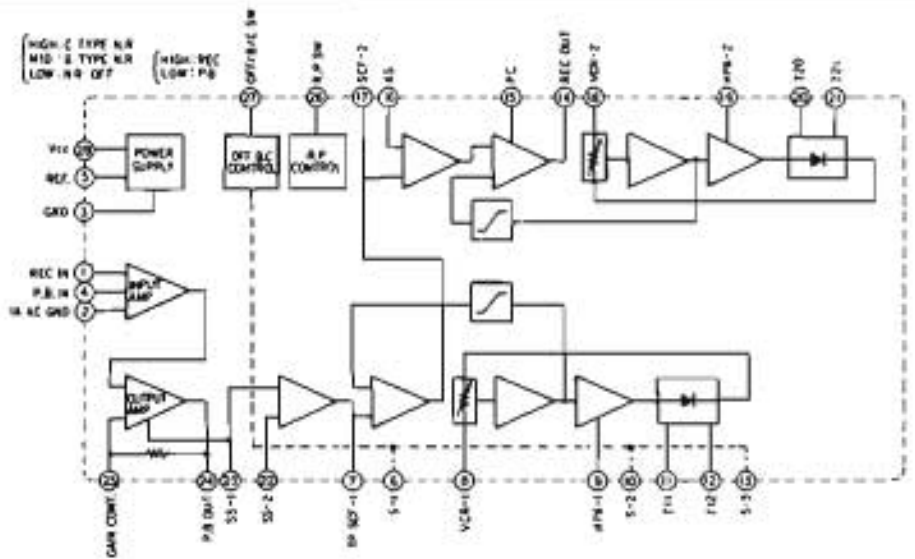
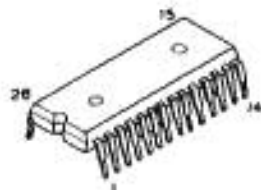

68248F01: IC601

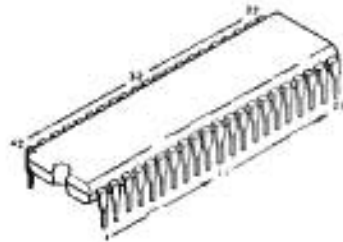

HD74LS139: IC602

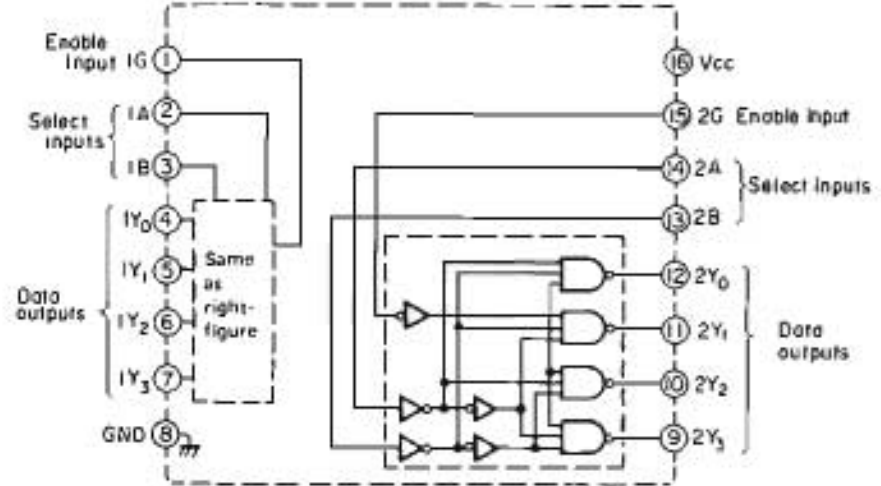

BA6229: IC603, IC604

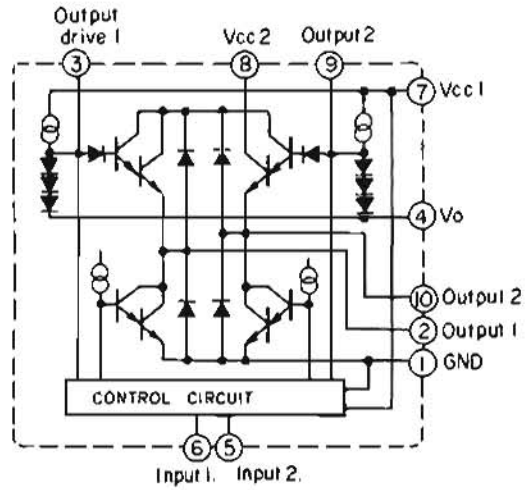
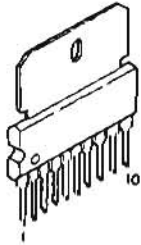

$\mu$ PC4558C: IC951, IC3102  
BA4558

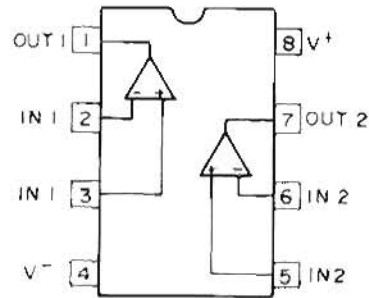

M51143AL: IC952

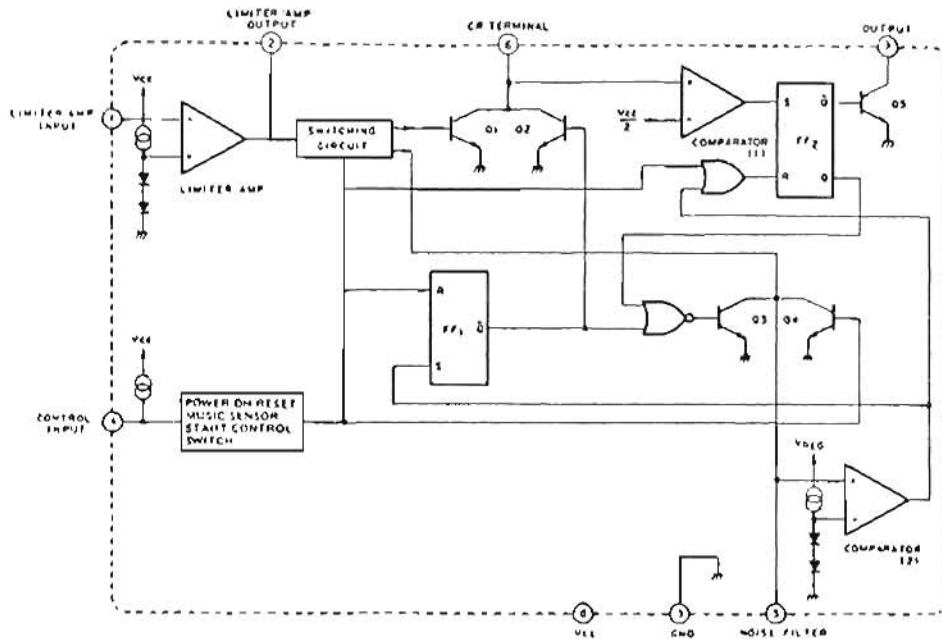
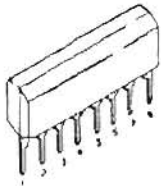

$\mu$ PD7507SCT-210: IC6301

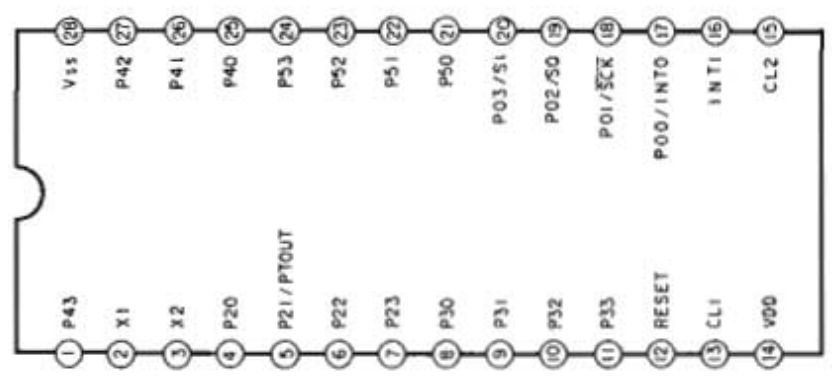
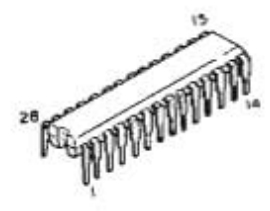

TC4069 $\mu$ BP: IC6302

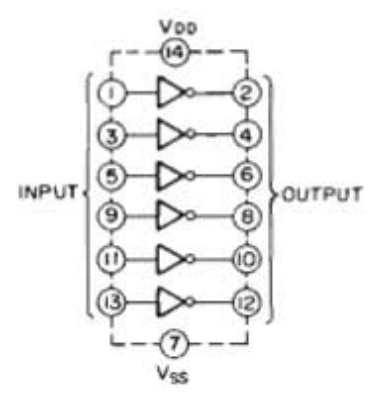
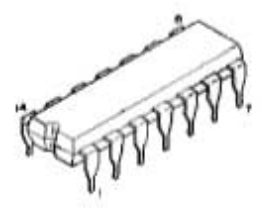

BA682A: IC8101, IC8102

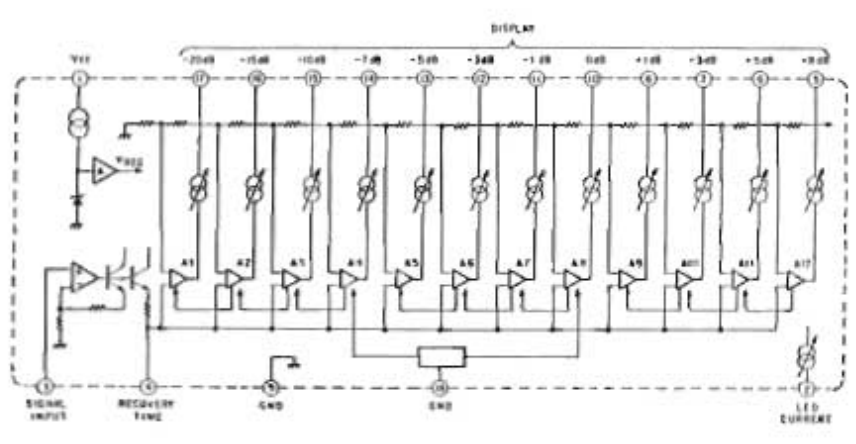
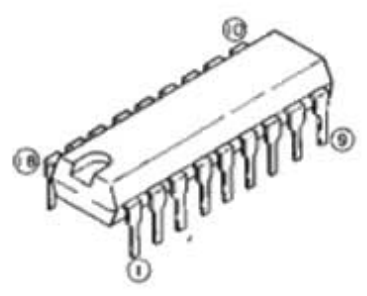

AN6291: IC3001, IC3101

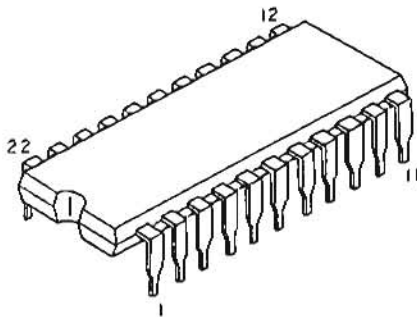

ENCODE / DECODE SWITCHING LOGIC CONDITIONS

PIN 11	PIN 12	OPERATION MODE
V <sub>CC</sub>	OPEN	DECODE
OPEN	V <sub>CC</sub>	ENCODE
V <sub>CC</sub>	V <sub>CC</sub>	BIAS

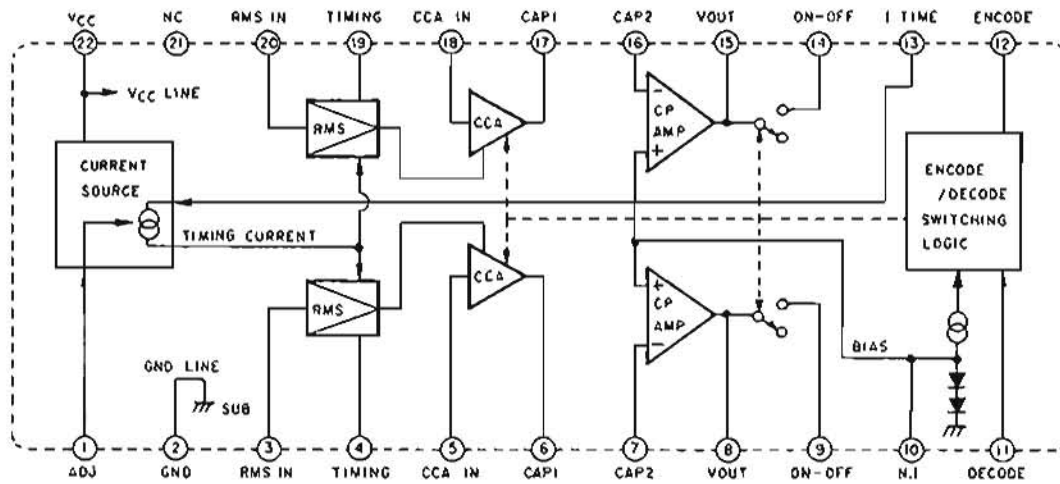

NJM2043D: IC3002

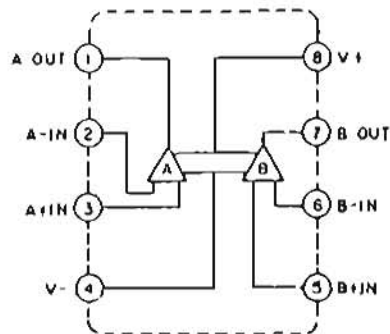
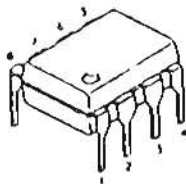

TC4066BP: IC3003  
BU4066B

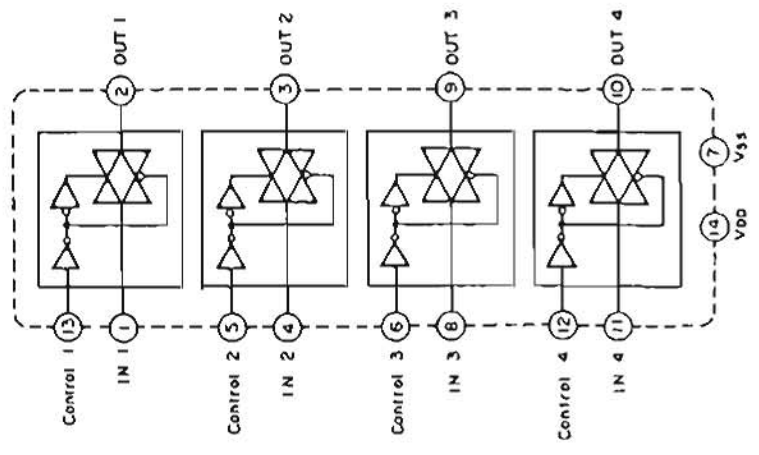
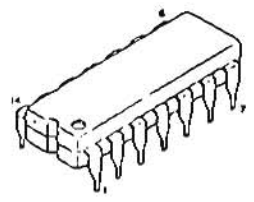

μPC1297: IC5101

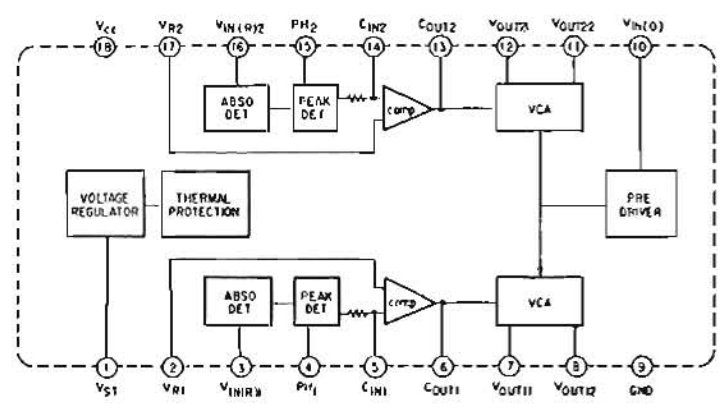
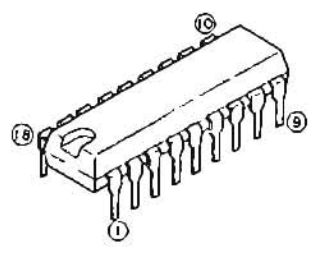

HD7447: IC6201

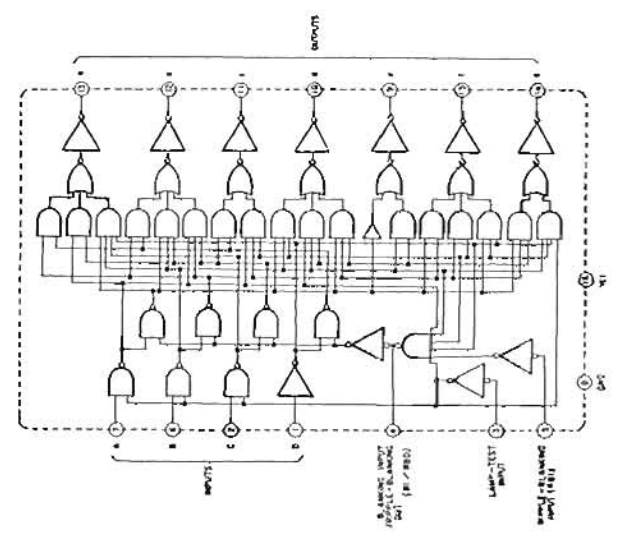

2SD1266: Q101, 102, 103  
2SD1406:



2SC2021: Q6301 ~ 6307, 6318, 6319, 6321 ~ 6324

2SA937: Q8331



2SC1318: Q104, 451, 452, 551, 552, 553

2SC2120: Q104, 451, 452, 553

2SC1740L } Q201, 202, 203, 204, 509, 510, 908  
2SC1843 }

2SC1740 } Q205 ~ 210, 212, 301, 401, 402, 501 ~ 506, 542, 580, 581,  
2SC1815 } Q604 ~ 609, 615 ~ 621, 633, 636, 901, 902, 905, 906, 909,  
Q951, 952, 955, 956, 3001 ~ 3004, 3081 ~ 3084,  
Q3101 ~ 3106, 5101 ~ 5106, 6501, 6502

2SA933A } Q211, 213, 541, 611 ~ 614, 631, 632, 635, 903, 907,  
2SC1015 } Q913 ~ 916, 953, 954

2SC1890 } Q243 ~ 246  
2SC1980 }

2SD1302: Q241, 242, 453, 454, 507, 508

2SA921: Q910





## **LUX CORPORATION, JAPAN**

2-3, 1-Chome, Minami-Yukigaya, Ohta-ku, Tokyo 145, JAPAN  
Phone 03-726-6211 Telex: 2466953LUXMAN Facsimile: 03-728-7609







IC	IC3001, IC3002 IC3003		IC3002 IC3102
Transistor (Q)	Q3001 Q3002	Q3003, Q3004, Q3103 Q3102, Q3006, Q3104	Q3005, Q3007, Q3084 Q3081
Diode (D, ZD)	D3002, D3001, D3003 D3002, D3101, D3103		ZD3081

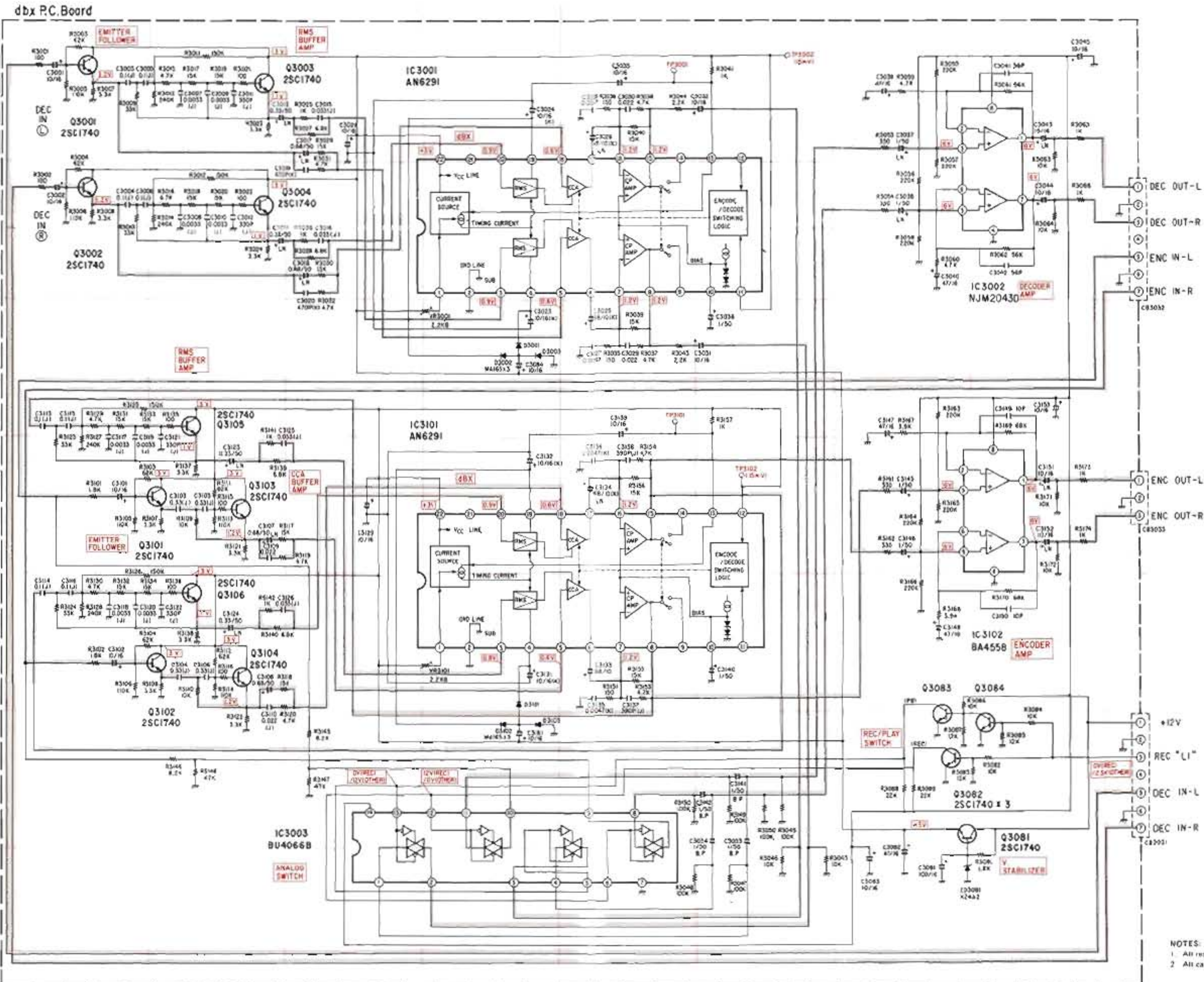

NOTES:  
 1. All resistance values are in ohms. K = 1,000  
 2. All capacitance values are in microfarads. P = 1,000,000