



LUXMAN

LUX CORPORATION, JAPAN

Service Manual

M-08

POWER AMPLIFIER

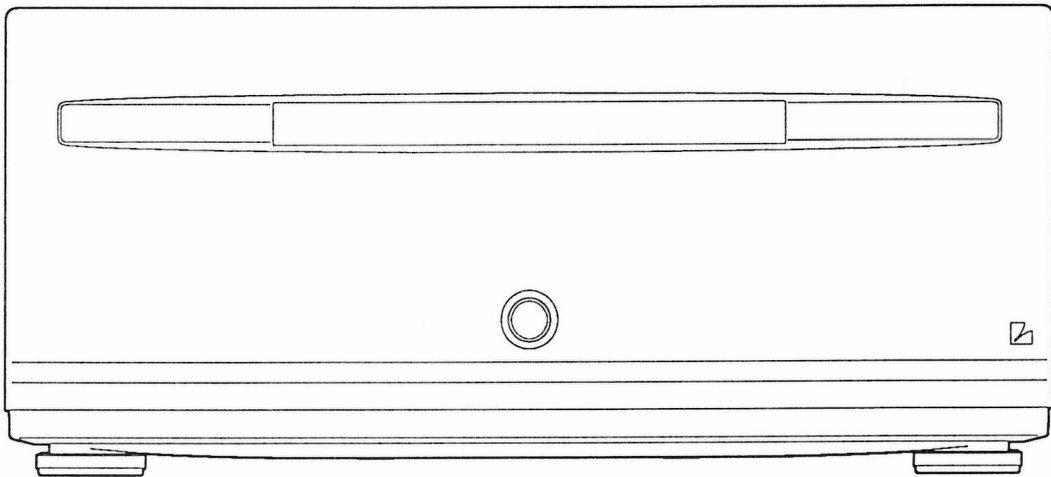

調整方法

1. ツェナー電流調整

調整用クリップ（ダイジクリップ）を、R343、344、443、444の各々の両端にセットし、その両端電圧をそれぞれVR341、342、441、442により、0.81Vに調整する。

- 注意**
- 1) 木箱をはずす必要がある場合、再度、取り付ける際には、ビス締めトルクを4.25kg/cm²にする。
 - 2) R343、344、443、444の真近に位置するバスバーは、+73Vもあるので、ダイジクリップの脱着に注意する。また、調整棒はプラスチック、セラミックなどの非金属のものを使用する。

2. アイドリング調整

CB3P1、4P1の①、③番端子間の電圧を、VR301、401により、115mVに調整する。

- 注意**
- 1) 調整を行なう際には、木箱をかぶせ、音楽を流し、1時間以上経過した後に行なう。

ブロックダイアグラム

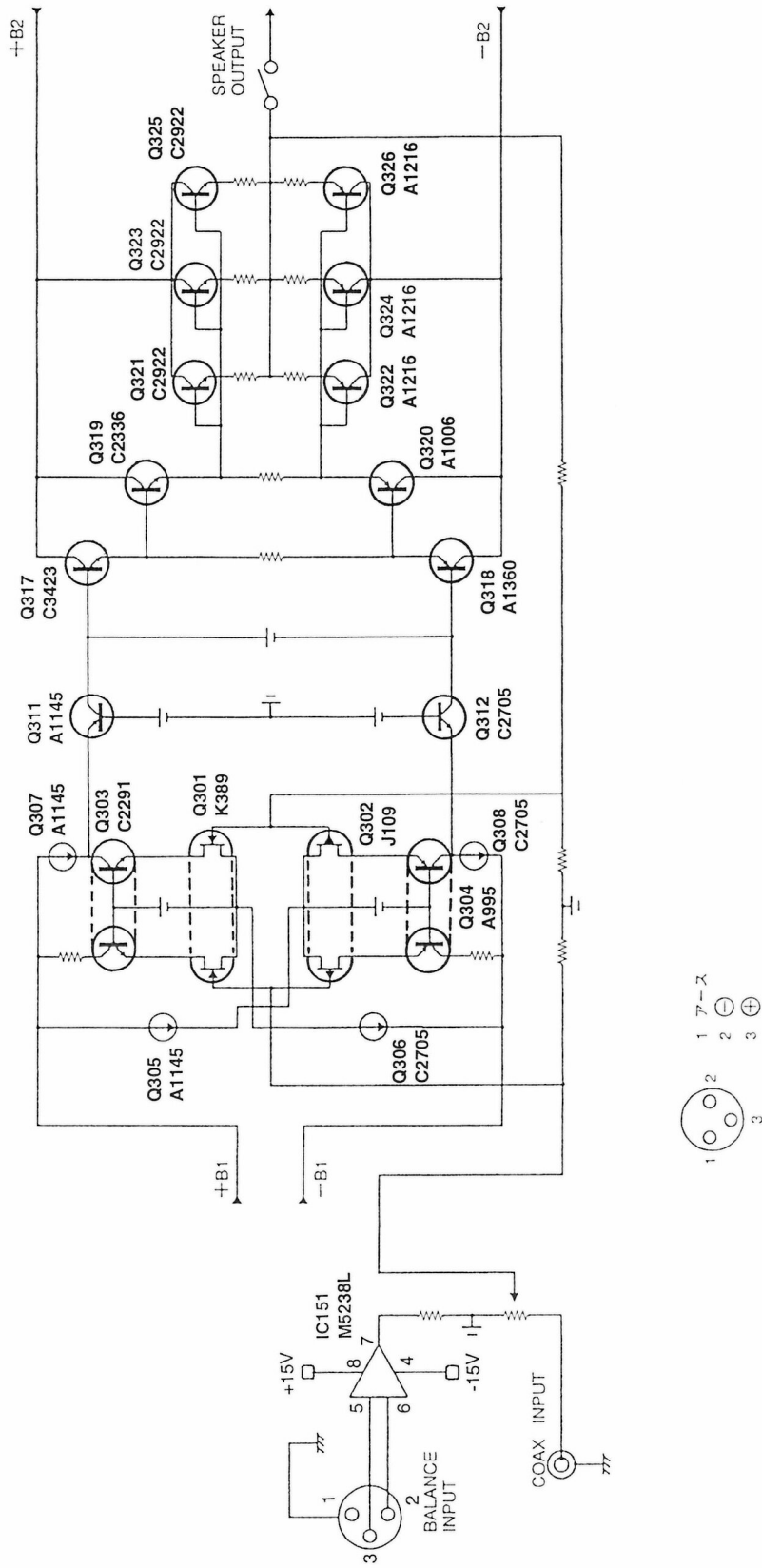

• AMP L, PT HL Boards

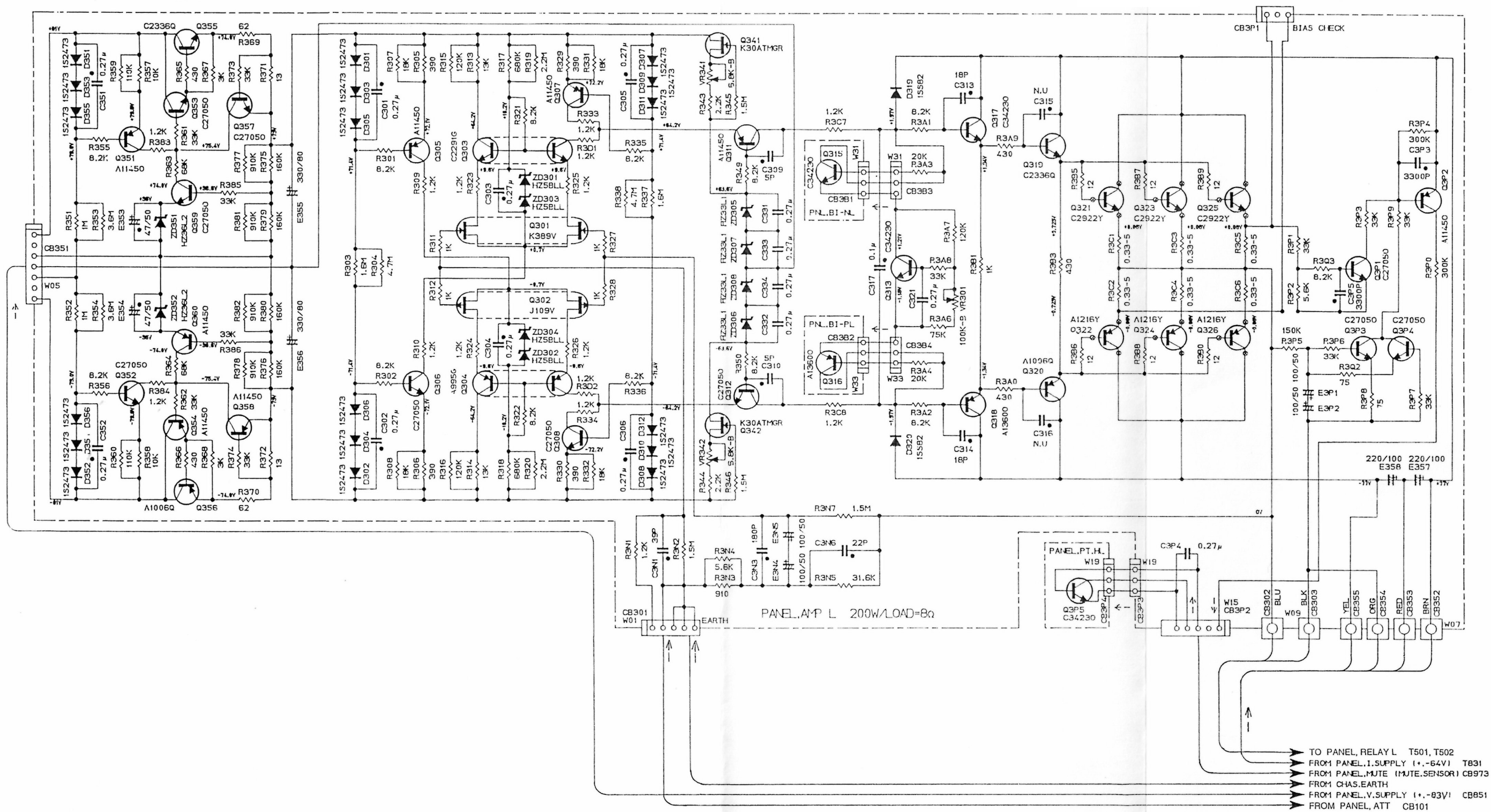

• AMP R, PT HR Boards

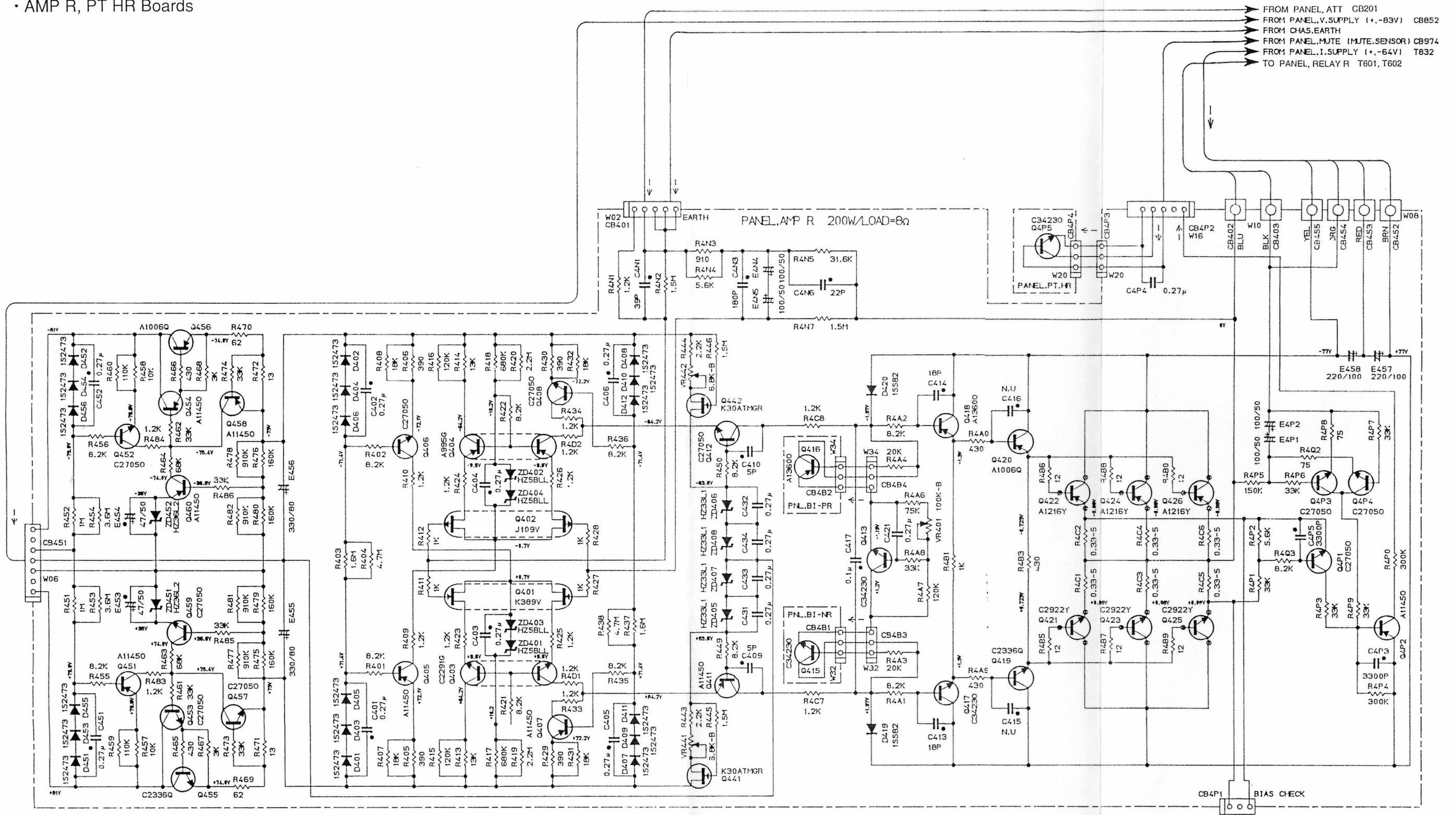

- FROM PANEL, ATT CB201
- FROM PANEL, V. SUPPLY (+, -63V) CB852
- FROM CHAS. EARTH
- FROM PANEL, MUTE (MUTE, SENSOR) CB974
- FROM PANEL, I. SUPPLY (+, -64V) T832
- TO PANEL, RELAY R T601, T602

• BAL AMP, ATT, RELAY L/R Boards

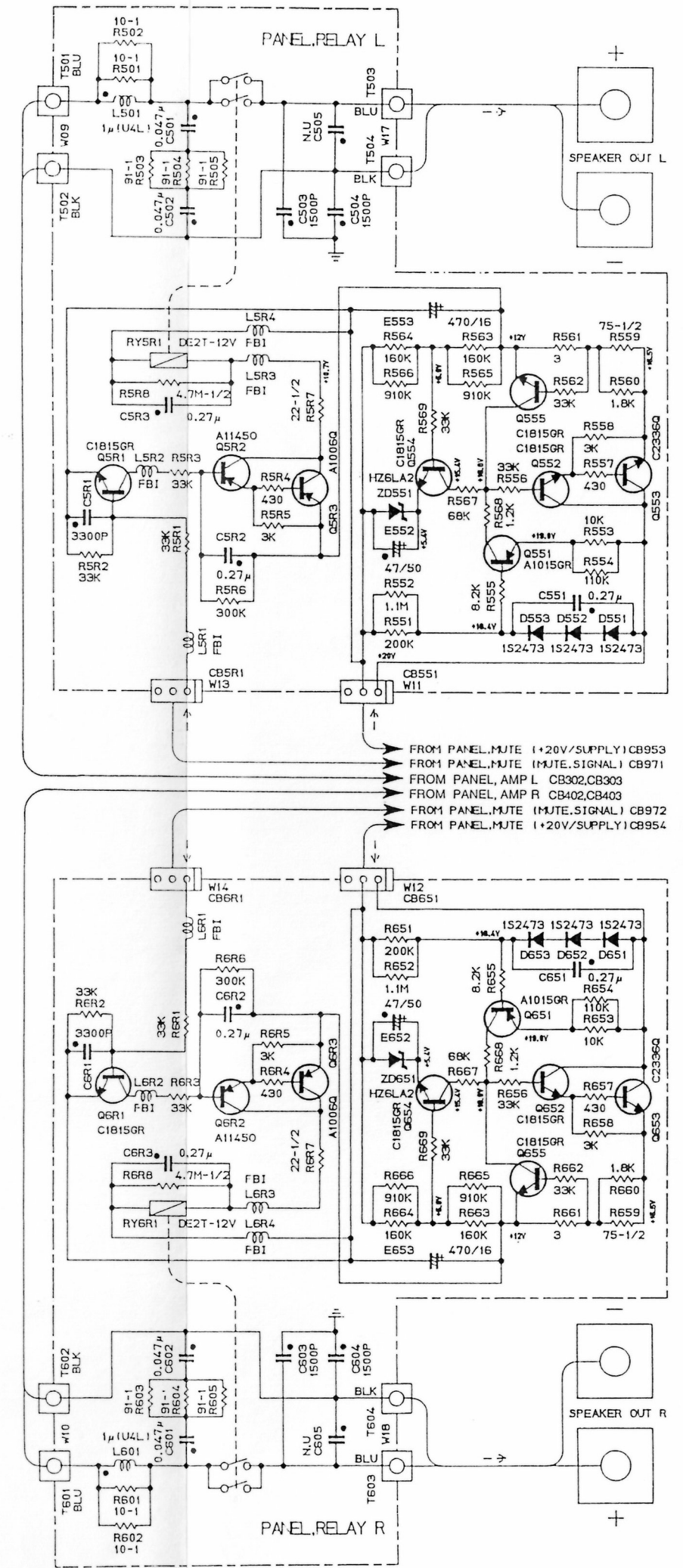
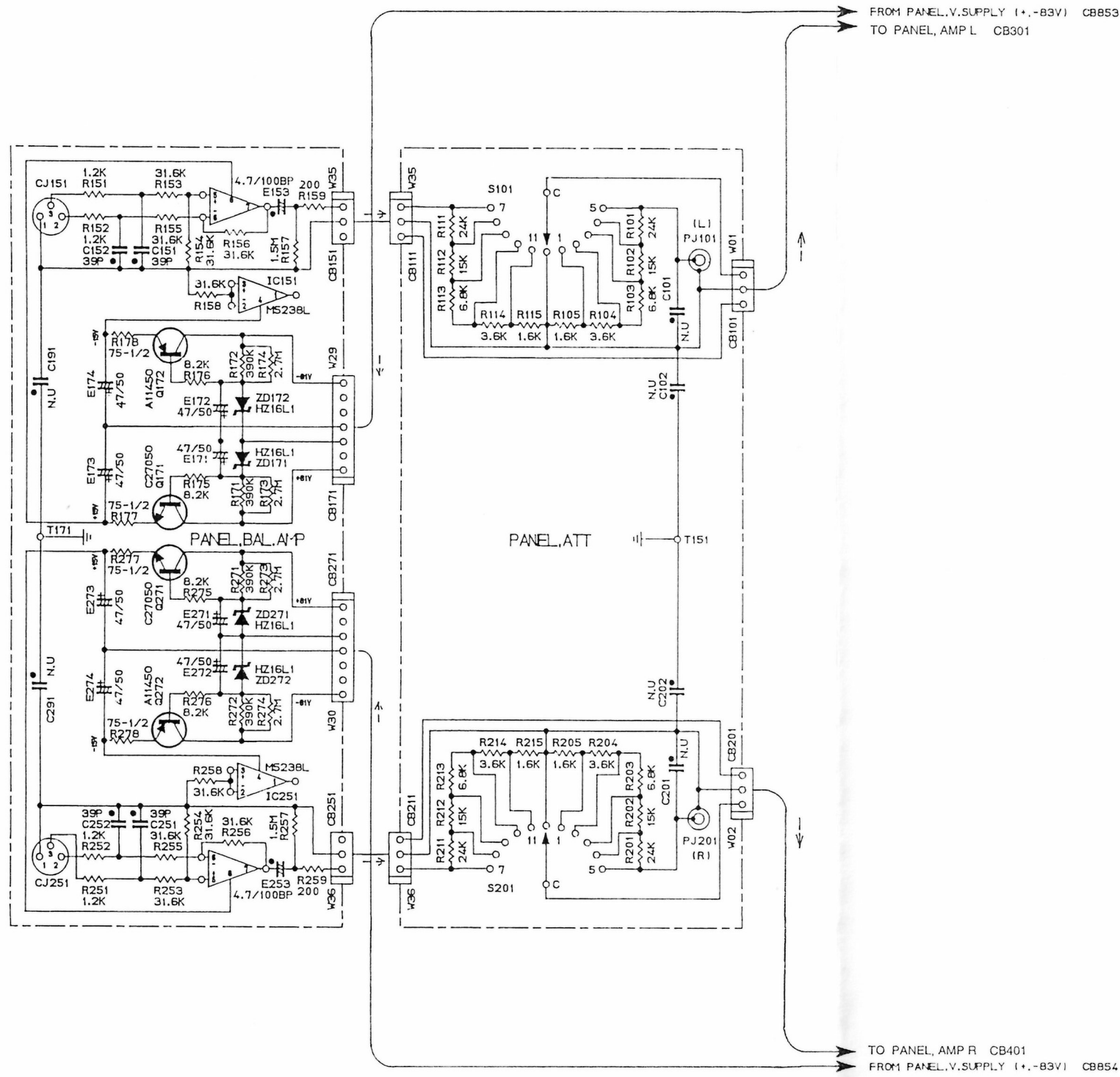

• I RECT, V SUPPLY Boards

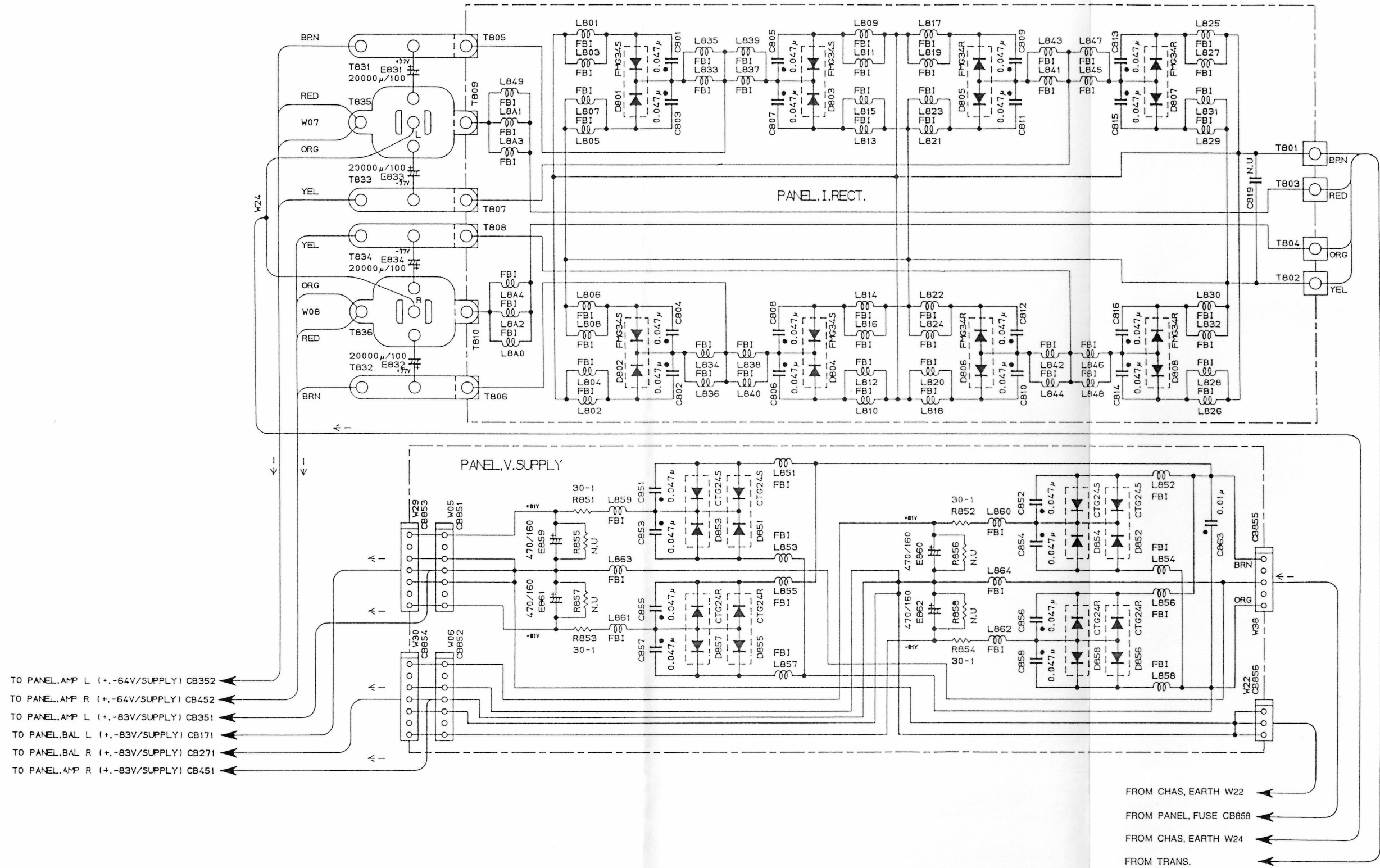

• LAMP, P I, MUTE Boards

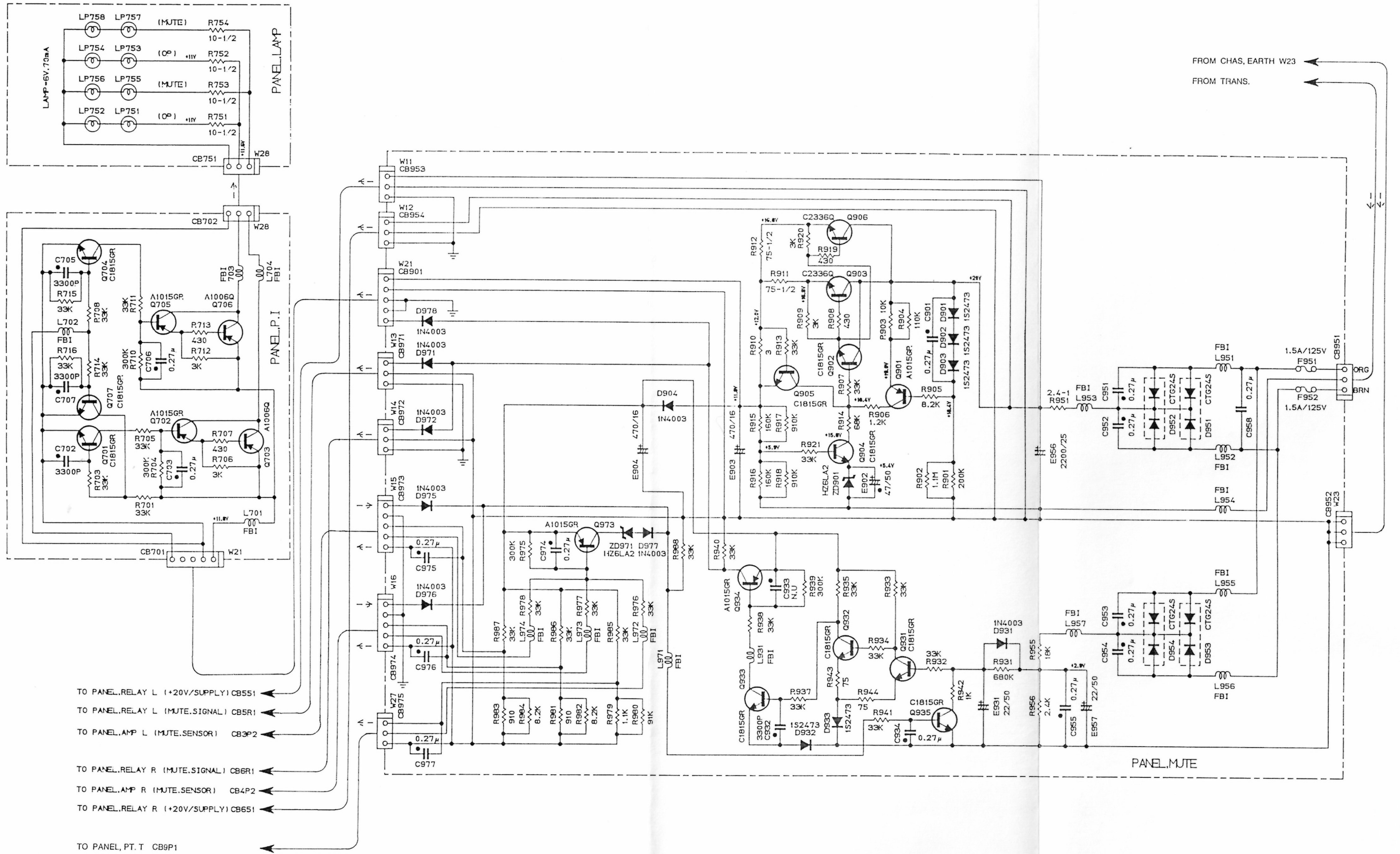

• TRANS, FUSE, PTT, AC SW Boards

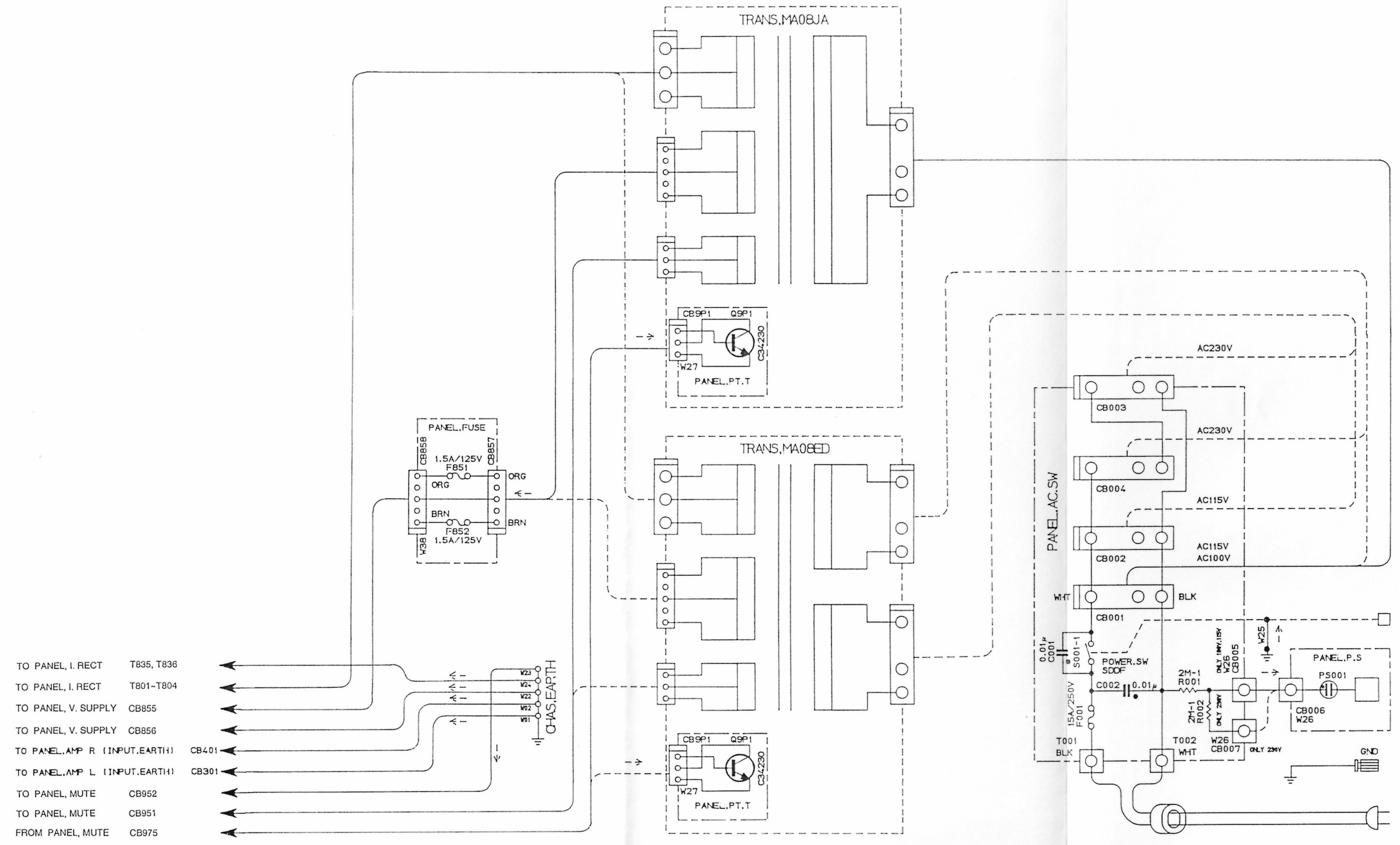

基板图

MUTE 基板

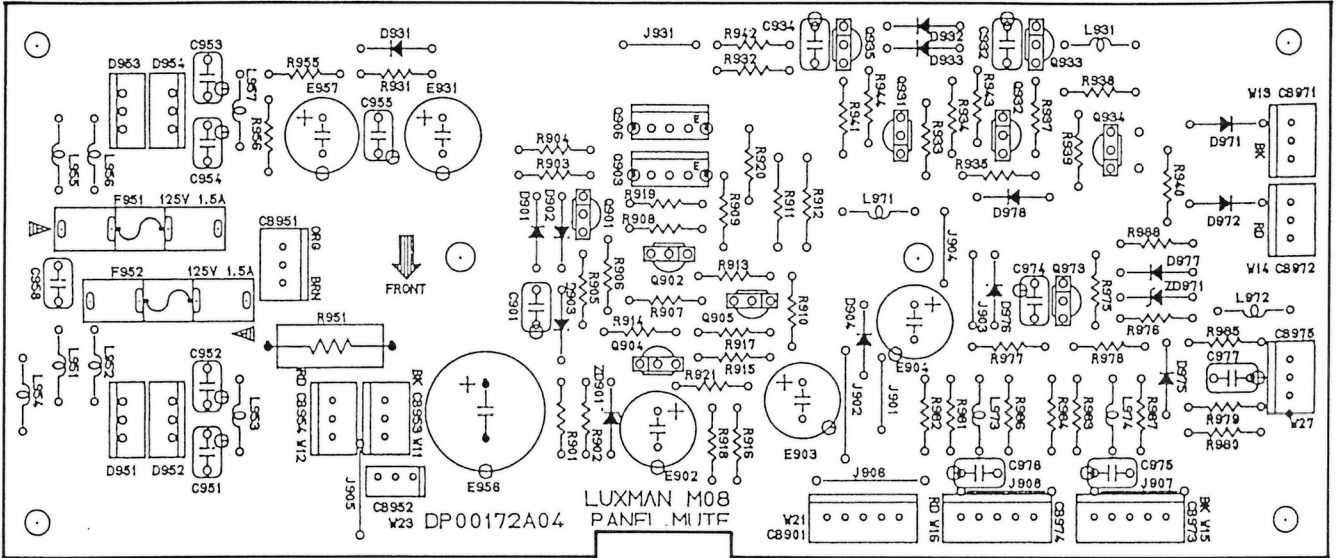

V. SUPPLY 基板

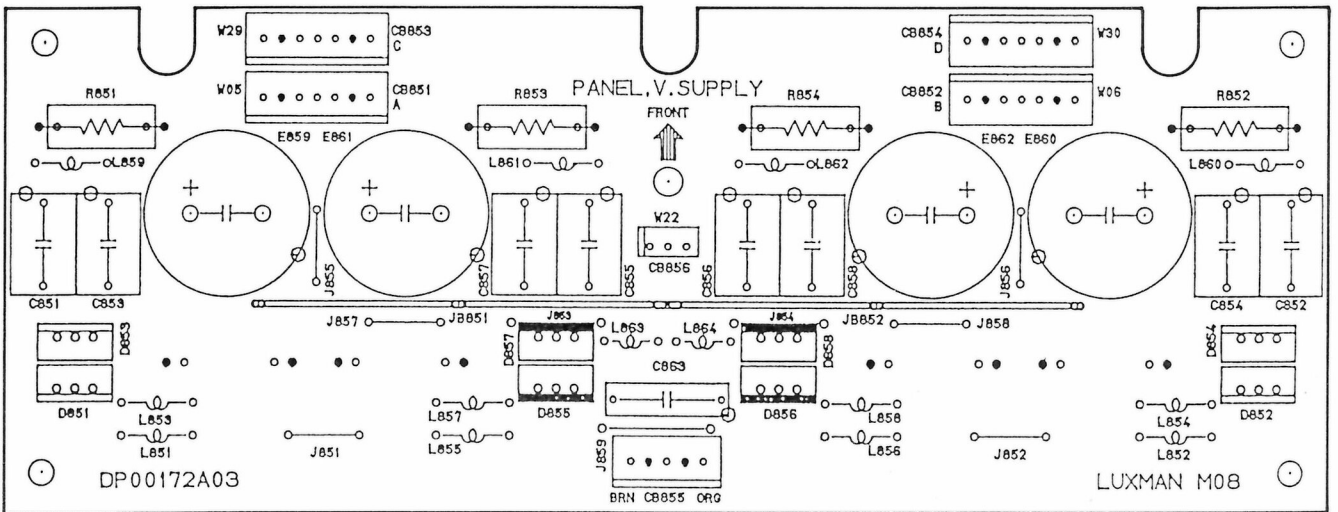

電氣關係部品表

Abbreviations			
RES. = Resistor	CAP. = Capacitor		
C.F. = Carbon Film	ELY. = Electrolytic		
M.F. = Metal Film	CER. = Ceramic		
M.O. = Metal Oxide Film	MYL. = Mylar		
M.P. = Metal Plate	TAN. = Tantalum		
TR. = Transistor	POLY. = Polystyrol		
TRANS. = Transformer	PP. = Polypropylene		
CP. = Chip	PLT. = Polyethylene		
	PF. = Polyester Film		
部品番号	部品名	個数	備考
AMP L 基板			
Transistors			
078-90076-23	FET,2SK389-V	1	Q301
078-90075-23	FET,2SJ109-V	1	Q302
078-32291-08	TR,2SC2291-G DUAL	1	Q303
078-10995-08	TR,2SA995-G DUAL	1	Q304
278-11145-16	TR,2SA1145-O	8	Q305,307,311,351, 354,358,360,3P2
278-32705-16	TR,2SC2705-O	10	Q306,308,312,352, 353,357,359,3P1, 3P3,3P4
078-33423-16	TR,2SC3423-O	2	Q313,317
078-11360-16	TR,2SA1360-O	1	Q318
078-32336-18	TR,2SC2336-Q	2	Q319,355
078-11006-18	TR,2SA1006-Q	2	Q320,356
078-32922-46	TR,2SC2922-P/Y	3	Q321,323,325
078-11216-46	TR,2SA1216-P/Y	3	Q322,324,326
078-90042-01	FET,2SK30ATM GR	2	Q341,342
Diodes			
278-50584-01	DIO,1S2473(35)	18	D301-312,351-356
278-50540-01	DIO,1SS82 TD	2	D319,320
078-50366-01	DIO,HZ5BLL	4	ZD301-304
078-50549X04	DIO,HZ33L-1 N-SEL	4	ZD305-308
078-50549-08	DIO,HZ36L-2	2	ZD351,352
Capacitors			
272-27521-67	CAP, 0.27 μ F 50V	13	C301-306,331-334, 351,352,3P4
050-45161X37	CAP,CMIB 5PF 250V	2	C309,310
050-45161X04	CAP,CMIB 18PF 250V	2	C313,314
050-45204X44	CAP,CPS 0.1 μ F	1	C317
272-33321-69	CAP,332J-ECQB1H(F)	3	C321,3P3,3P5
050-45161X08	CAP,CMIB 39PF 250V	1	C3N1
050-45161X16	CAP,CMIB 180PF 250V	1	C3N3
050-45161X05	CAP,CMIB 22PF 250V	1	C3N6
050-44799-25	CAP,EC 47 μ F 50V	2	E353,354
050-45188X01	CAP,EC 330 μ F 80V	2	E355,356
050-44799-58	CAP,EC 220 μ F 100V	2	E357,358
050-45117-01	CAP,EC 100 μ F 50V	4	E3P1,3P2,3N4,3N5
Resistors			
076-38220-59	RES,RM 8.2k Ω J 1W	13	R301,302,321,322, 335,336,349,350, 355,356,3A1,3A2, 3Q3
部品番号	部品名	個数	備考
076-31650-59	RES,RM 1.6M Ω J 1W	2	R303,337
076-34750-59	RES,RM 4.7M Ω J 1W	2	R304,338
076-33901-59	RES,RM 390 Ω J 1W	4	R305,306,329,330
076-31830-59	RES,RM 18k Ω J 1W	4	R307,308,331,332
076-31220-59	RES,RM 1.2k Ω J 1W	15	R309,310,323-326, 333,334,383,384, 3C7,3C8,3D1,3D2, 3N1,
076-31020-59	RES,RM 1k Ω J 1W	5	R311,312,327,328, 3B1
076-31330-59	RES,RM 13k Ω J 1W	2	R313,314
076-31240-59	RES,RM 120k Ω J 1W	3	R315,316,3A7,
076-36840-59	RES,RM 680k Ω J 1W	2	R317,318
076-32250-59	RES,RM 2.2M Ω J 1W	2	R319,320
076-32220-59	RES,RM 2.2k Ω J 1W	2	R343,344
076-31550-59	RES,RM 1.5M Ω J 1W	4	R345,346,3N2,3N7
076-31050-59	RES,RM 1M Ω J 1W	2	R351,352
076-33650-59	RES,RM 3.6M Ω J 1W	2	R353,354
076-31030-59	RES,RM 10k Ω J 1W	2	R357,358
076-31140-59	RES,RM 110k Ω J 1W	2	R359,360
076-33330-59	RES,RM 33k Ω J 1W	12	R361,362,373,374, 385,386,3A8,3P1, 3P3,3P6,3P7,3P9
076-36830-59	RES,RM 68k Ω J 1W	2	R363,364
076-34310-59	RES,RM 430 Ω J 1W	5	R365,366,3A0,3A9, 3B3
076-33020-59	RES,RM 3k Ω J 1W	2	R367,368
076-36201-59	RES,RM 62 Ω J 1W	2	R369,370
076-31301-59	RES,RM 13 Ω J 1W	2	R371,372
076-31640-59	RES,RM 160k Ω J 1W	4	R375,376,379,380
076-39140-59	RES,RM 910k Ω J 1W	4	R377,378,381,382
076-32030-59	RES,RM 20k Ω J 1W	2	R3A3,3A4
076-37530-59	RES,RM 75k Ω J 1W	1	R3A6
076-31201-59	RES,RM 12 Ω J 1W	6	R3B0,3B5-3B9
050-45075-01	RES,LOR 0.33 Ω J 5W	6	R3C1-3C6
076-39110-59	RES,RM 910 Ω J 1W	1	R3N3
050-45129-01	RES,RM 31.6k Ω G 1W	1	R3N5
076-33040-59	RES,RM 300k Ω J 1W	2	R3P0,3P4
076-35620-59	RES,RM 5.6k Ω J 1W	2	R3P2,3N4
076-37501-59	RES,RM 75 Ω J 1W	2	R3P8,3Q2
076-31540-59	RES,RM150k Ω J 1W	1	R3P5
050-45076-04	RHEOSTAT 100KB	1	VR301
050-45076-02	RHEOSTAT 6.8KB	2	VR341,342
Others			
002-48823-05	CON.BASE(5045-05A)	1	CB301
002-48899-09	ASS'Y WIRE OUT,L	1	CB302,303
002-48899-05	ASS'Y WIRE SUP,V-L	1	CB351
050-45121-01	TERMINAL M1700	4	CB352-355
002-48823-03	CON.BASE(5045-03A)	3	CB3B3,3B4,3P3
002-48799-03	CON.BASE(5046-03A)	1	CB3P1
002-48899-15	ASS'Y WIRE PRSE-L	1	CB3P2
202-48110-02	JUMPING WIRE	1	(12.5mm)J301
050-45127-01	JUMPER.RM 1/4W	4	J302,3P3-3P5

部品番号	部品名	個数	備考
202-48110-01	JUMPING WIRE	17	(10mm)J303,304,306-313,351,355,356,3P1,3P6,3P8,3Q1
002-48110-03	JUMPING WIRE	2	(15mm)J3P0,3P9
202-48110-03	JUMPING WIRE	1	(15mm)J3P2
060-45198X01	BUS BAR L-86	7	JB301,303,305-307,310,312
060-44674-01	WIRE JUMPER 56MM	9	JB302,304,308,309,311,313-315,351
050-43758-06	GLASS TUBE 1.0-10	26	(10mm)USE TO J3P3-3P5,R3B0,3B3,3B5-3B9,3C7,3C8,3P5(×2)
060-45440-05	CUSHION SHIELD 10	4	USE TO C3N3,3N6,E353,354
060-45440-04	CUSHION SHIELD 12	2	USE TO E3N4,3N5
050-43758-11	GLASS TUBE 1.0-6	12	(6mm) USE TO R3C1-3C6(×2)
060-45206X01	HEAT SINK-TR	2	USE TO 2SA798
060-32391X01	HEAT SINK-FET	2	USE TO FET
060-23381-01	HEAT SINK M08-L	1	AL,クロ・アルマイト
060-23403-01	HEAT SINK M08-R	1	AL,クロ・アルマイト
060-45204-01	HEAT SINK (A)	4	CU,T=1.5
060-45205-01	HEAT SINK (B)	4	CU,T=1.5
060-45159-01	HEAT SINK TR	2	CU,T=0.8
060-45207X01	BKT HEAT SINK	4	
060-32366-01	SHIELD HEAT SINK	2	CU
060-45208-01	HOLDER HEAT SINK	4	
097-40216-18	SCR MCH M3×6 W/W CU	6	USE TO AMP L
097-40112-02	3×8 B-TITE EARTH SCREW	16	USE TO BKT HEAT SINK(8),HOLDER HEAT SINK(8)
097-40216-14	SCR.MCH M3×6 BIN CU	5	USE TO Q313,317-320
097-40216-28	SCR.MCH(W/W) M3×10	3	USE TO Q315,316,3P5
097-40216-27	SCR.MCH(W/W) M3×14	12	USE TO Q321-326(×2)
002-48487-06	CON.BS6P-SHF-1AA	6	USE TO Q321-326
060-45210-03	INSULATOR TR TO-220(D-1)	2	USE TO Q319,320
060-45210-02	INSULATOR TR	1	USE TO Q321-326
050-44682-01	BUSHING.YC40B	2	USE TO Q319,320
012-46250-01	TIE	13	W05(3),W15(3),06(3),16(4)
060-44679-01	SPACER B M3×10	12	
AMP R 基板			
Transistors			
078-90076-23	FET,2SK389-V	1	Q401
078-90075-23	FET,2SJ109-V	1	Q402
078-32291-08	TR,2SC2291-G DUAL	1	Q403
078-10995-08	TR,2SA995-G DUAL	1	Q404
278-11145-16	TR,2SA1145-O	8	Q405,407,411,451,454,458,460,4P2
278-32705-16	TR,2SC2705-O	10	Q406,408,412,452,453,457,459,4P1,4P3,4P4
078-33423-16	TR,2SC3423-O	2	Q413,417
078-11360-16	TR,2SA1360-O	1	Q418
078-32336-18	TR,2SC2336-Q	2	Q419,455
078-11006-18	TR,2SA1006-Q	2	Q420,456
078-32922-46	TR,2SC2922-P/Y	3	Q421,423,425

部品番号	部品名	個数	備考
078-11216-46	TR,2SA1216-P/Y	3	Q422,424,426
078-90042-01	FET,2SK30ATM GR	2	Q441,442
Diodes			
278-50584-01	DIO,1S2473(35)	18	D401-412,451-456
278-50540-01	DIO,1SS82 TD	2	D419,420
078-50366-01	DIO,HZ5BLL	4	ZD401-404
078-50549X04	DIO,HZ33L-1 N-SEL	4	ZD405-408
078-50549-08	DIO,HZ36L-2	2	ZD451,452
Capacitors			
272-27521-67	CAP, 0.27μF 50V	13	C401-406,431-434,451,452,4P4
050-45161X37	CAP,CMIB 5PF 250V	2	C409,410
050-45161X04	CAP,CMIB 18PF 250V	2	C413,414
050-45204X44	CAP,CPS 0.1μF	1	C417
272-33321-69	CAP,332J-ECQB1H(F)	3	C421,4P3,4P5
050-45161X08	CAP,CMIB 39PF 250V	1	C4N1
050-45161X16	CAP,CMIB 180PF 250V	1	C4N3
050-45161X05	CAP,CMIB 22PF 250V	1	C4N6
050-44799-25	CAP,EC 47μF 50V	2	E453,454
050-45188X01	CAP,EC 330μF 80V	2	E455,456
050-44799-58	CAP,EC 220μF 100V	2	E457,458
050-45117-01	CAP,EC 100μF 50V	4	E4P1,4P2,4N4,4N5
Resistors			
076-38220-59	RES,RM 8.2kΩ J 1W	13	R401,402,421,422,435,436,449,450,455,456,4A1,4A2,4Q3
076-31650-59	RES,RM 1.6MΩ J 1W	2	R403,437
076-34750-59	RES,RM 4.7MΩ J 1W	2	R404,438
076-33910-59	RES,RM 390Ω J 1W	4	R405,406,429,430
076-31830-59	RES,RM 18kΩ J 1W	4	R407,408,431,432
076-31220-59	RES,RM 1.2kΩ J 1W	15	R409,410,423-426,433,434,483,484,4C7,4C8,4D1,4D2,4N1,
076-31020-59	RES,RM 1kΩ J 1W	5	R411,412,427,428,4B1
076-31330-59	RES,RM 13kΩ J 1W	2	R413,414
076-31240-59	RES,RM 120kΩ J 1W	3	R415,416,4A7,
076-36840-59	RES,RM 680kΩ J 1W	2	R417,418
076-32250-59	RES,RM 2.2MΩ J 1W	2	R419,420
076-32220-59	RES,RM 2.2kΩ J 1W	2	R443,444
076-31550-59	RES,RM 1.5MΩ J 1W	4	R445,446,4N2,4N7
076-31050-59	RES,RM 1MΩ J 1W	2	R451,452
076-33650-59	RES,RM 3.6MΩ J 1W	2	R453,454
076-31030-59	RES,RM 10kΩ J 1W	2	R457,458
076-31140-59	RES,RM 110kΩ J 1W	2	R459,460
076-33330-59	RES,RM 33kΩ J 1W	12	R461,462,473,474,485,486,4A8,4P1,4P3,4P6,4P7,4P9
076-36830-59	RES,RM 68kΩ J 1W	2	R463,464
076-34310-59	RES,RM 430Ω J 1W	5	R465,466,4A0,4A9,4B3
076-33020-59	RES,RM 3kΩ J 1W	2	R467,468
076-36201-59	RES,RM 62Ω J 1W	2	R469,470
076-31301-59	RES,RM 13Ω J 1W	2	R471,472
076-31640-59	RES,RM 160kΩ J 1W	4	R475,476,479,480
076-39140-59	RES,RM 910kΩ J 1W	4	R477,478,481,482
076-32030-59	RES,RM 20kΩ J 1W	2	R4A3,4A4

部品番号	部品名	個数	備考
076-37530-59	RES,RM 75kΩ J 1W	1	R4A6
076-31201-59	RES,RM 12Ω J 1W	6	R4B0,4B5-4B9
050-45075-01	RES,LOR 0.33Ω J 5W	6	R4C1-4C6
076-39110-59	RES,RM 910Ω J 1W	1	R4N3
050-45129-01	RES,RM 31.6kΩ G 1W	1	R4N5
076-33040-59	RES,RM 300kΩ J 1W	2	R4P0,4P4
076-35620-59	RES,RM 5.6kΩ J 1W	2	R4P2,4N4
076-31540-59	RES,RM150kΩ J 1W	1	R4P5
076-37501-59	RES,RM 75Ω J 1W	2	R4P8,4Q2
050-45076-04	RHEOSTAT 100KB	1	VR401
050-45076-02	RHEOSTAT 6.8KB	2	VR441,442
Others			
002-48823-05	CON.BASE(5045-05A)	1	CB401
002-48899-10	ASS'Y WIRE OUT,R	1	CB402,403
002-48899-06	ASS'Y WIRE SUP,V-R	1	CB451
050-45121-01	TERMINAL M1700	4	CB452-455
002-48823-03	CON.BASE(5045-03A)	3	CB4B3,4B4,4P3
002-48799-03	CON.BASE(5046-03A)	1	CB4P1
002-48899-16	ASS'Y WIRE PRSE-R	1	CB4P2
202-48110-02	JUMPING WIRE	1	(12.5mm)J401
050-45127-01	JUMPER.RM 1/4W	4	J402,4P3-4P5
202-48110-01	JUMPING WIRE	17	(10mm)J403,404, 406-413,451,455 456,4P1,4P6,4P8, 4Q1
002-48110-03	JUMPING WIRE	2	(15mm)J4P0,4P9
202-48110-03	JUMPING WIRE	1	(15mm)J4P2
060-45198X01	BUS BAR L-86	7	JB401-403,405,407, 410,412
060-44674-01	WIRE JUMPER 56MM	9	JB404,406,408,409, 411,413-415,451
050-43758-06	GLASS TUBE 1.0-10	26	(10mm)USE TO J4P3-4P5,R4B0, 4B3,4B5-4B9,4C7 4C8,4P5(×2)
060-45440-05	CUSHION SHIELD 10	4	USE TO C4N3,4N6, E453,454
060-45440-04	CUSHION SHIELD 12	2	USE TO E4N4,4N5
050-43758-11	GLASS TUBE 1.0-6	12	(6mm) USE TO R4C1-4C6(×2)
097-40216-18	SCR MCH M3×6 W/W CU	6	USE TO AMP R(6)
097-40216-14	SCR.MCH M3×6 BIN CU	5	USE TO Q413,417-420
097-40216-28	SCR.MCH(W/W) M3×10	3	USE TO Q415,416,4P5
097-40216-27	SCR.MCH(W/W) M3×14	12	USE TO Q421-426(×2)
002-48487-06	CON.BS6P-SHF-1AA	6	USE TO Q421-426
060-45210-03	INSULATOR TR TO-220(D-1)	2	USE TO Q419,420
060-45210-02	INSULATOR TR	1	USE TO Q421-426
050-44682-01	BUSHING.YC40B	2	USE TO Q419,420
BAL. AMP 基板			
IC's			
078-00961-01	IC,M5238L	2	IC151,251
Transistors			
278-32705-16	TR,2SC2705-0	2	Q171,271
278-11145-16	TR,2SA1145-0	2	Q172,272
Diodes			
078-50545-82	DIO,HZ16-1L	4	ZD171,172,271,272

部品番号	部品名	個数	備考
Capacitors			
050-45161X08	CAP,CMIB 39PF 250V	4	C151,152,251,252
074-47640-50	CAP,EC 4.7μF 100V ARBP	2	E153,253
050-44799-25	CAP,EC 47μF 50V	8	E171-174,271-274
Resistors			
076-31220-59	RES,RM 1.2kΩ J 1W	4	R151,152,251,252
050-45129-01	RES,RM 31.6kΩ G 1W	10	R153-156,158, 253-256,258
076-31550-59	RES,RM 1.5MΩ J 1W	2	R157,257
076-32010-59	RES,RM 200Ω J 1W	2	R159,259
276-33940-29	RES,RD25S 390kΩ J	4	R171,172,271,272
276-32750-29	RES,RD25S 2.7MΩ J	4	R173,174,273,274
276-38220-29	RES,RD25S 8.2kΩ J	4	R175,176,275,276
050-44664-95	RES,RDF50SL 75Ω J	4	R177,178,277,278
Others			
002-48823-03	CON.BASE (5045-03A)	2	CB151,251
002-48899-29	ASS'Y WIRE BAL,V-L	1	CB171
002-48899-30	ASS'Y WIRE BAL,V-R	1	CB271
202-48110-01	JUMPING WIRE	4	(10mm) J111,172, 211,272
060-44969-01	LUG PCB	1	T171
ATT 基板			
Resistors			
076-32430-59	RES,RM 24kΩ J 1W	4	R101,111,201,211
076-31530-59	RES,RM 15kΩ J 1W	4	R102,112,202,212
076-36820-59	RES,RM 6.8kΩ J 1W	4	R103,113,203,213
076-33620-59	RES,RM 3.6kΩ J 1W	4	R104,114,204,214
076-31620-59	RES,RM 1.6kΩ J 1W	4	R105,115,205,215
Others			
002-48899-01	ASS'Y WIRE INPUT,L	1	CB101
002-48899-35	ASS'Y WIRE IN,BAL-L	1	CB111
002-48899-02	ASS'Y WIRE INPUT,R	1	CB201
002-48899-36	ASS'Y WIRE IN,BAL-R	1	CB211
050-45122-01	SW ROTARY SRRM1BS-S15P	2	S101,201
060-44969-01	LUG PCB	1	T151
RELAY. L 基板			
Transistors			
278-11015-31	TR,2SA1015GR	1	Q551
278-31815-31	TR,2SC1815-GR	4	Q552,554,555,5R1
078-32336-18	TR,2SC2336-Q	1	Q553
278-11145-16	TR,2SA1145-0	1	Q5R2
078-11006-18	TR,2SA1006-Q	1	Q5R3
Diodes			
278-50584-01	DIO,1S2473 (35)	3	D551-553
078-50545-35	DIO,HZ6A-2L	1	ZD551
Capacitors			
050-45120-08	CAP,MC SH 0.047μF 630V	2	C501,502
050-45161X27	CAP,CMIB 1500PF	2	C503,504
272-27521-67	CAP,0.27μF 50V	3	C551,5R2,5R3
272-33321-69	CAP,332J-ECQB1H (F)	1	C5R1
050-44799-25	CAP,EC 47μ 50V	1	E552
074-47844-49	CAP,EC 470μF 16V	1	E553

部品番号	部品名	個数	備考
Resistors			
076-31001-59	RES,RM 10Ω J 1W	2	R501,502
076-39101-59	RES,RM 91Ω J 1W	3	R503-505
276-32040-29	RES,RD25S 200kΩ J	1	R551
276-31150-29	RES,RD25S 1.1MΩ J	1	R552
276-31030-29	RES,RD25S 10kΩ J	1	R553
276-31140-29	RES,RD25S 110kΩ J	1	R554
276-38220-29	RES,RD25S 8.2kΩ J	1	R555
276-33330-29	RES,RD25S 33kΩ J	6	R556,562,569, 5R1-5R3
276-34310-29	RES,RD25S 430Ω J	2	R557,5R4
276-33020-29	RES,RD25S 3kΩ J	2	R558,5R5
076-37501-49	RES,RM 75Ω J 1/2W	1	R559
276-31820-29	RES,RD25S 1.8kΩ J	1	R560
076-33002-29	RES,RD25S 3Ω J	1	R561
276-31640-29	RES,RD25S160kΩ J	2	R563,564
276-39140-29	RES,RD25S 910kΩ J	2	R565,566
276-36830-29	RES,RD25S 68kΩ J	1	R567
276-31220-29	RES,RD25S 1.2kΩ J	1	R568
276-33040-29	RES,RD25S 300kΩ J	1	R5R6
076-32201-49	RES,RM 22Ω J 1/2W	1	R5R7
076-34750-49	RES,RM 4.7MΩ J 1/2W	1	R5R8
Others			
250-44679-01	FBI BLO1RN1-A63T6	4	L5R1-5R4
002-48899-11	ASS'Y WIRE REL,V-L	1	CB551
002-48899-13	ASS'Y WIRE REL,S-L	1	CB5R1
202-48110-01	JUMPING WIRE	2	(10mm)J5R1,5R2
050-45160-01	COIL U4L 1UHK	1	L501
050-44670-01	RELAY DE2T-DC12V	1	RY5R1
050-45121-01	TERMINAL M1700	4	T501-504
060-45440-05	CUSHION SHIELD 10	2	USE TO E552,553
RELAY. R 基板			
Transistors			
278-11015-31	TR,2SA1015GR	1	Q651
278-31815-31	TR,2SC1815-GR	4	Q652,654,655,6R1
078-32336-18	TR,2SC2336-Q	1	Q653
278-11145-16	TR,2SA1145-0	1	Q6R2
078-11006-18	TR,2SA1006-Q	1	Q6R3
Diodes			
278-50584-01	DIO,1S2473 (35)	3	D651-653
078-50545-35	DIO,HZ6A-ZL	1	ZD651
Capacitors			
050-45120-08	CAP,MC SH 0.047μF 630V	2	C601,C602
050-45161X27	CAP,CMIB 1500PF	2	C603,C604
272-27521-67	CAP,0.27μF 50V	3	C651,C6R2,C6R3
272-33321-69	CAP,332J-ECQB1H (F)	1	C6R1
050-44799-25	CAP,EC 47μF 50V	1	E652
074-47844-49	CAP,EC 470μF 16V	1	E653
Resistors			
076-31001-59	RES,RM 10Ω J 1W	2	R601,R602
076-39101-59	RES,RM 91Ω J 1W	3	R603-605
276-32040-29	RES,RD25S 200kΩ J	1	R651
276-31150-29	RES,RD25S 1.1MΩ J	1	R652
276-31030-29	RES,RD25S 10kΩ J	1	R653

部品番号	部品名	個数	備考
276-31140-29	RES,RD25S 110kΩ J	1	R654
276-38220-29	RES,RD25S 8.2kΩ J	1	R655
276-33330-29	RES,RD25S 33kΩ J	6	R656,662,669,6R1-6R3
276-34310-29	RES,RD25S 430Ω J	2	R657,6R4
276-33020-29	RES,RD25S 3kΩ J	2	R658,6R5
076-37501-49	RES,RM 75Ω J 1/2W	1	R659
276-31820-29	RES,RD25S 1.8kΩ J	1	R660
076-33002-29	RES,RD25S 3Ω J	1	R661
276-31640-29	RES,RD25S 160kΩ J	2	R663,664
276-39140-29	RES,RD25S 910kΩ J	2	R665,666
276-36830-29	RES,RD25S 68kΩ J	1	R667
276-31220-29	RES,RD25S 1.2kΩ J	1	R668
276-33040-29	RES,RD25S 300kΩ J	1	R6R6
076-32201-49	RES,RM 22Ω J 1/2W	1	R6R7
076-34750-49	RES,RM 4.7MΩ J 1/2W	1	R6R8
Others			
002-48899-12	ASS'Y WIRE REL,V-R	1	CB651
002-48899-14	ASS'Y WIRE REL,S-R	1	CB6R1
202-48110-01	JUMPING WIRE	1	(10mm) J6R1
050-45160-01	COIL U4L 1UHK	1	L601
250-44679-01	FBI BLO1RN1-A63T6	4	L6R1-6R4
050-44670-01	RELAY DE2T-DC12V	1	RY6R1
050-45121-01	TERMINAL M1700	4	T601-604
060-45440-05	CUSHION SHIELD 10	2	USE TO E652,653
I. RECT. 基板			
Diodes			
078-50580-01	DIO,FMG-34S	4	D801-804
078-50581-01	DIO,FMG-34R	4	D805-808
Capacitors			
050-45120-08	CAP,MC SH 0.047μF 630V	16	C801-816
Others			
060-45228-01	WIRE JUMPER 48MM	4	JB801-804
250-44679-01	FBI BLO1RN1-A63T6	54	L801-849,8A0-8A4
050-45121-01	TERMINAL M1700	10	T801-810
097-40216-27	SCR MCH(W/W) M3×14	8	USE TO D801-808
V. SUPPLY 基板			
Diodes			
078-50582-01	DIO,CTG-24S	4	D851-854
078-50583-01	DIO,CTG-24R	4	D855-858
Capacitors			
050-45120-08	CAP,MC SH 0.047μF 630V	8	C851-858
050-44808-03	CAP,DC 0.01μF 250V	1	C863
050-45118X01	CAP,EC 470μF 160V	4	E859-862
Resistors			
076-33001-59	RES,RM 30Ω J 1W	4	R851-854
Others			
002-48823-07	CON.BASE(5045-07A)	4	CB851-854
002-48823-05	CON.BASE(5045-05A)	2	CB855
002-48899-22	ASS'Y WIRE V.S.E	1	CB856
202-48110-01	JUMPING WIRE	6	(10mm) J851,852, 855-858
202-48110-02	JUMPING WIRE	2	(12.5mm) J853,854

部品番号	部品名	個数	備考
202-48110-03	JUMPING WIRE	1	(15mm) J859
060-44674-01	WIRE JUMPER 56MM	2	JB851,852
250-44679-01	FBI BL01RN1-A63T6	12	L851-862
050-44679-01	FBI BL01RN1-A62	2	L863,864 (P=7.5)
050-43758-06	GLASS TUBE 1.0-10	8	(10mm) USE TO R851-854 (×2)
MUTE 基板			
Transistors			
278-11015-31	TR,2SA1015GR	3	Q901,934,973
278-31815-31	TR,2SC1815-GR	7	Q902,904,905,931-933,935
078-32336-18	TR,2SC2336-Q	2	Q903,906
Diodes			
278-50584-01	DIO,1S2473(35)	5	D901-903,932,933
278-50539-01	DIO,GP10-4003E-G3	8	D904,931,971,972,975-978
078-50582-01	DIO,CTG-24S	4	D951-954
078-50545-35	DIO,HZ6A-2L	2	ZD901,971
Capacitors			
272-27521-67	CAP,MC 0.27μF 50V	12	C901,934,951-955,958,974-977
272-33321-69	CAP,MC 332J-ECQB1H(F)	1	C932
050-44799-25	CAP,EC 47μF 50V	1	E902
074-47844-49	CAP,EC 470μF 16V	2	E903,904
050-44799-23	CAP,EC 22μF 50V	2	E931,957
074-22945-49	CAP,EC 2200μF 25V	1	E956
Resistors			
276-32040-29	RES,RD25S 200kΩ J	1	R901
276-31150-29	RES,RD25S 1.1MΩ J	1	R902
276-31030-29	RES,RD25S 10kΩ J	1	R903
276-31140-29	RES,RD25S 110kΩ J	1	R904
276-38220-29	RES,RD25S 8.2kΩ J	3	R905,982,984
276-31220-29	RES,RD25S 1.2kΩ J	1	R906
276-33330-29	RES,RD25S 33kΩ J	18	R907,913,921,932-935,937,938,940,941,976-978,985-988
276-34310-29	RES,RD25S 430Ω J	2	R908,919
276-33020-29	RES,RD25S 3kΩ J	2	R909,920
076-33002-29	RES,RD25S 3Ω J	1	R910
076-37501-49	RES,RM 75Ω J 1/2W	2	R911,912
276-36830-29	RES,RD25S 68kΩ J	1	R914
276-31640-29	RES,RD25S 160kΩ J	2	R915,916
276-39140-29	RES,RD25S 910kΩ J	2	R917,918
076-36840-29	RES,RD25S 680kΩ J	1	R931
276-33040-29	RES,RD25S 300kΩ J	2	R939,975
276-31020-29	RES,RD25S 1kΩ J	1	R942
076-37501-29	RES,RD25S 75Ω J	2	R943,944
076-32402-59	RES,RM 2.4Ω J 1W	1	R951
276-31830-29	RES,RD25S 18kΩ J	1	R955
276-32420-29	RES,RD25S 2.4kΩ J	1	R956
276-31120-29	RES,RD25S 1.1kΩ J	1	R979
276-39130-29	RES,RD25S 91kΩ J	1	R980
276-39110-29	RES,RD25S 910Ω J	2	R981,983
Others			
002-48823-05	CON.BASE(5045-05A)	3	CB901,973,974

部品番号	部品名	個数	備考
002-48823-03	CON.BASE(5045-03A)	6	CB951,953,954,971,972,975
002-48899-23	ASS'Y WIRE MUTE,E	1	CB952
202-48110-01	JUMPING WIRE	4	(10mm) J901,903,904,931
202-48110-03	JUMPING WIRE	2	(15mm) J902,906
202-48110-02	JUMPING WIRE	3	(12.5mm) J905,907,908
250-44679-01	FBI BL01RN1-A63T6	12	L931,951-957,971-974
060-45440-05	CUSHION SHIELD 10	4	USE TO E903,904,931,957
060-45440-03	CUSHION SHIELD 16	1	USE TO E956
050-44684-01	FUSE HOLDER	4	USE TO F951,952 (×2)
050-43758-06	GLASS TUBE 1.0-10	2	(10mm) USE TO R951 (×2)
002-48899-37	LEAD WIRE	2	JA-B,JC-D
012-46250-01	TIE	17	W01-W02(1),W29(8),W30(8)
P. I. 基板			
Transistors			
278-31815-31	TR,2SC1815-GR	3	Q701,704,707
278-11015-31	TR,2SA1015GR	2	Q702,705
078-11006-18	TR,2SA1006-Q	2	Q703,706
Capacitors			
272-33321-69	CAP,MC 332J-ECQB1H (F)	3	C702,705,707
272-27521-67	CAP,MC 0.27μF 50V	2	C703,706
Resistors			
276-33330-29	RES,RD25S 33kΩ J	8	R701,703,705,708,711,714-716
276-33040-29	RES,RD25S 300kΩ J	2	R704,710
276-33020-29	RES,RD25S 3kΩ J	2	R706,712
276-34310-29	RES,RD25S 430Ω J	2	R707,713
Others			
250-44679-01	FBI,BL01RN1-A63T6	4	L701-704
002-48899-21	ASS'Y WIRE P.I	1	CB701
002-48899-28	ASS'Y WIRE LAMP	1	CB702
097-40091-04	NYLON RIVET	2	USE TO Q703,706
202-48110-01	JUMPER WIRE	2	(10mm) USE TO J701,702
LAMP 基板			
Resistors			
076-31001-49	RES,RM 10Ω J 1/2W	4	R751-754
Others			
002-48799-03	CON.BASE (5046-03A)	1	CB751
050-45156-01	LAMP 6-70 (A3666-CLEAR)	4	LP751-754
050-45156-02	LAMP 6-70 (A3666-02Y12.5)	4	LP755-758
050-45168-06	LED SPACER LH-5-6	8	USE TO LP751-758
AC. SW 基板			
Capacitors			
050-44808-03	CAP,DC 0.01μF 250V	2	C001,002
Resistor			
076-32050-59	RES,RM 2MΩ J 1W	1	R002

部品番号	部品名	個数	備考
Others			
002-48900-03	WTB 5285-03A	1	CB001
002-48899-26	ASS'Y WIRE P.S	1	CB005-CB006
050-44674-01	TERMINAL M1698 (M3)	2	G001,002
050-45124-01	SW POWER SDDFA3	1	S001
002-48800-01	1P TERMINAL (IPS-4009)	2	T001,002
050-45201-01	HOLDER FUSE YSH-401T	2	USE TO F001 (×2)
012-46250-01	TIE	24	W11-13(9),21(5), 12-14(10)
P. S 基板			
Other			
050-44290-01	ASS'Y. PHASE SENSOR	1	PS001
FUSE 基板			
Others			
002-48823-05	CON.BASE (5045-05A)	1	CB857
002-48899-38	ASS'Y WIRE PT2V	1	CB858
050-44684-01	FUSE HOLDER	4	USE TO F851,852 (×2)
BI-NL 基板			
Transistor			
078-33423-16	TR,2SC3423-0	1	Q315
Others			
002-48899-31	ASS'Y WIRE BI-NL	1	CB3B1-3B3
002-48855-01	HOLDER WIRE 3P	1	USE TO Q315
BI-NR 基板			
Transistor			
078-33423-16	TR,2SC3423-0	1	Q415
Others			
002-48899-32	ASS'Y WIRE BI-NR	1	CB4B1-4B3
002-48855-01	HOLDER WIRE 3P	1	USE TO Q415

部品番号	部品名	個数	備考
BI-PL 基板			
Transistor			
078-11360-16	TR,2SA1360-0	1	Q316
Others			
002-48899-33	ASS'Y WIRE BI-PL	1	CB3B2-3B4
002-48855-01	HOLDER WIRE 3P	1	USE TO Q316
BI-PR 基板			
Transistor			
078-11360-16	TR,2SA1360-0	1	Q416
Others			
002-48899-34	ASS'Y WIRE BI-PR	1	CB4B2-4B4
002-48855-01	HOLDER WIRE 3P	1	USE TO Q416
PT. HL 基板			
Transistor			
078-33423-16	TR,2SC3423-0	1	Q3P5
Others			
002-48899-19	ASS'Y WIRE PT,HL	1	CB3P4-CB3P3
002-48855-01	HOLDER WIRE 3P	1	USE TO Q3P5
PT. HR 基板			
Transistor			
078-33423-16	TR,2SC3423-0	1	Q4P5
Others			
002-48899-20	ASS'Y WIRE PT,HR	1	CB4P4-CB4P3
002-48855-01	HOLDER WIRE 3P	1	USE TO Q4P5
PT. T 基板			
Transistor			
078-33423-16	TR,2SC3423-0	1	Q9P1
Others			
002-48899-27	ASS'Y WIRE PRT	1	CB9P1
002-48855-01	HOLDER WIRE 3P	1	USE TO Q9P1

キャビネット関係部品表

記号	部品番号	部品名	個数	備考	記号	部品番号	部品名	個数	備考
	060-11318-01	APPEARANCE				060-45262-01	SHAFT POWER	1	SUB
	060-32425-01	PACKING SPECIFICATION				060-45263-01	SHAFT JOINT	1	BSBM2
	050-985-01	P.C BOARD ASS'Y	1			060-11299-01	PANEL FRONT	1	A6063
	050-986-01	P.C BOARD ASS'Y	1						アルマイトシルク
	050-987-01	P.C BOARD ASS'Y	1			060-32392-01	CRYSTAL DISPLAY M08	1	T=13 アクリル
	060-32401-01	CHAS TRANS BASE (A)	1	SPC T=1.2 CU メッキ塗装		060-32393-01	LENS POWER IND M08	1	T=13 ガラスブラスト
	060-32404-01	CHAS TRANS BASE (B)	1	SPC T=1.2 CU メッキ塗装		060-32411-01	SHIELD ATT	1	T=1 SECC-P 塗装
	050-45111-01	TRANS POWER	1			060-32394-01	ACRYL POWER IND C08	1	ACRYL 塗装
	060-23379-01	CHAS TRANS SIDE (L)	1	T=1.2 SPC CU メッキ塗装		060-45239-01	ESCUT KNOB POWER	1	ABS スパッタリング
	060-23380-01	CHAS TRANS SIDE (R)	1	T=1.2 SPC CU メッキ塗装		060-43247-08	CUSHION (70×10)	6	N9790B
	050-45139-01	CANON NEW TRIC	2			060-11311-01	COVER BOTTOM	1	FRP PAINTED
	060-32368-01	SHIELD PCB	1	T=1.2 SPC CU メッキ塗装		060-45270-01	EDGE ES1916 SADDLES	1	
	060-11296-01	CHAS REAR	1	T=1.2 SECC-P 塗装		060-45260-01	COVER METAL (L)	1	T=1 SPC PANTING METAL
	060-45229-01	BKT CHAS TRANS	2	T=1.6 SECC-P 塗装		060-45261-01	COVER METAL (R)	1	T=1 SPC PANTING METAL
	060-11300-01	CHAS FRONT	1	T=1.2 SECC-P 塗装		060-45217-01	ASS'Y TRANNLEG	4	
	060-23377-01	CHAS SIDE (L)	1	T=1.2 SECC-P 塗装		060-45218-01	PAD TRANNLEG	4	
	060-23378-01	CHAS SIDE (R)	1	T=1.2 SECC-P 塗装		060-45219-01	PAD TRANNLEG	1	
	060-45258-01	BKT PCB	2			002-48899-07	ASS'Y WIRE SUP,I-L	1	
	060-32367-01	HEAT SINK S	2	T=5 A1100P クロアルマイト		060-23405-01	WOOD CAB	1	ローズウッド塗装
	060-44897-01	HEAT SINK BLOCK	2	T=1 C1100P		060-45266-01	SPACER WOOD	4	ラワン
	060-32413-01	SHIELD AC	1	T=1 SECC-P 塗装		060-32412-01	COVER WOOD CAB	2	T=1 SECC-P 塗装
	060-11297-01	COVER REAR	1	T=1.2 SECC-P 塗装シルク		060-45264-01	KNOB ROTARY VOL	2	5056S ゴールドアルマイト
	060-23421-01	DESIGN				060-45265-01	KNOB POWER	1	5056S ゴールドアルマイト
	060-11297C01	REAR PANEL	1			060-23441-01	DESIGN		
	050-45108-01	T5907-A SP TERM (RED)	2			060-23442-01	DESIGN		
	050-45108-02	T5907-B SP TERM (WHT)	2			060-45221-01	INS.CVR D7×27 T=0.16	4	
	002-48899 -25	ASS'Y WIRE SP.E	1			060-45220-01	SCR WOOD CAB	4	
	002-48899-17	ASS'Y WIRE OUT PUT IL	1			060-44678-03	SPACER(A) M3×8	8	BS
	002-48899-18	ASS'Y WIRE OUT PUT IR	1			060-44678-04	SPACER(A) M3×16	3	BS
	002-48899-24	ASS'Y WIRE I.S.E	1			060-44678-05	SCR(A) M3×20	1	BS
	002-48899-08	ASS'Y WIRE SUP,I-R	1			060-44890-03	C.B SPACER (RSPLS-8L)	3	NYLON
	050-45109-01	T5435A TERMINAL GND	1			060-44890-02	C.B SPACER (RSPLS-6L)	8	NYLON
	050-45110-01	T5613L PHONE JACK 1P	2			060-44890-04	C.B SPACER (RSPLS-10L)	10	NYLON
	060-32088-01	COVER SENSOR	1			060-45271-01	SUP.PCB KGLS-16 BLK	5	NYLON BLACK
	060-32397-01	STOPPER CORD	1	PVC		060-45271-02	SUP.PCB KGLS-20 BLK	4	NYLON BLACK
	050-44775-01	AC CORD (BK0048-F03)	1			012-46250-01	TIE	27	
	050-44827-01	フェライトクランプ TRCC20-10-10	1			060-44681-06	CLAMP, MSC-1609	32	PVC
	060-45288-01	O133 SCREW GROMET	3			060-44681-07	CLAMP, MSC-1611	5	
	060-45224-01	BUS BARCON (A)	2	T=1.6 C1100P		060-44681-08	CLAMP, MSC-1613	2	PVC
	060-45227-01	BUS BARCON (B)	2	T=1.6 C1100P		060-45222-01	BUSH SQUARE SB1909	18	NYLON
	060-45259-01	BUS BARCON (C)	2	T=1.6 C1100P		060-45312-01	BUSHING M5	4	DELRIN
	060-45269-01	BUS BARCON (D)	2	T=1.6 C1100P		050-44682-01	BUSHING.YC40B	4	
	060-32434-01	BACK PLATE	1	ALP T=1 ALMITE		060-45314-01	SCREW COVER WOOD	12	
						060-44678-06	SPACER(A)	2	BS MBN12
						097-40014-08	3×8 BIND B-TITE SCREW	28	SWR MFCZN2-B
						097-40112-02	3×8 B-TITE EARTH SCREW	20	SWR MFCZN2-B
						097-40216-09	4×8 BIND B-TITE EARTH. SCR	16	SWR MFCUN2 頭部黒塗装

記号	部品番号	部品名	個数	備考
	097-40216-10	M5×18 HEXAGON SEMS SCR	4	SWR MFCU2
	097-40216-11	M4×6 BIND MCH SCREW	8	CU
	097-40043-16	M3×4 BIND MCH SCREW	2	SWR MFZN2-B
	097-40216-13	M3×4 BIND MCH EARTH SCR	13	SWR MFZN2-B
	097-40216-14	SCR.MCH M3×6 BIN CU	38	CU
	097-40216-15	M4×10 BIND MCH SCR	1	CU
	097-40216-16	4×8 BIND B-TITE EARTH SCR	36	SWR MFZN2-B
	097-40216-17	3×8 FLAT D-TITE SCR	8	SWR MFZN2-B
	097-40216-18	SCR MCH M3×6 W/W CU	14	SWR MFCU2
	097-40043-15	M3×8 BIND MCH SCREW	16	SWR MFZN2-B
	097-40216-20	M4×14 BIND MCH SCREW	4	SWR MFZN2-B
	097-40216-21	M4×18 BIND S-TITE SEMS.SCR	6	SWR MFZN2-B
	097-40216-22	M4×20 BIND S-TITE SCR	3	SWR MFZN2-B
	097-40216-23	3×6 FRANGE B-TITE SCR	4	SWR MFCU2
	097-40216-24	M3×8 BIND MCH EARTH.SCR	8	SWR MFCU2 頭部黒塗装
	097-40216-25	4×10 BIND BTITE EARTH.SCR	6	SW MFCU2
	097-40216-26	M4×10 PAN S-TITE SEMS SCR	4	SWR MFZN2-B
	097-40217-03	6 WASHER	1	SPC MFZN2
	097-40217-04	9 WASHER	2	CU
	050-45119Y01	EC 20000μF 100V	4	LUX CUTOM
	060-45286-02	SHEET CU 25×25	4	CU T0.085
	060-44678-07	SPACER(A) M3×10	2	BS
	060-45370X01	LABEL TRANS L580	1	
	050-45155-19	SM FUSE 250V 15A	1	F001
	050-45223-03	FGMT5-125V-1.5V	4	F851,852,951,952

記号	部品番号	部品名	個数	備考
	060-45443-01	MINI CLAMP SF-111	1	
	060-44842-03	TUBE VI 4.7	1	
	060-45382-09	CUSHION SHIELD CAB	2	
	060-45439-01	CUSHION SHIELD BOT A	1	
	060-45382-10	CUSHION SHIELD BOT B	1	
	060-45440-01	CUSHION SHIELD 63	4	E831,832,833,834
	060-45441-01	CUSHION SHIELD ATT	1	
	060-45382-11	CUSHION RUBBER 163×10	2	
	060-45442-01	INS CVR 300×70 CU	1	
	060-45286-27	INS CVR 420×40 CU	1	
	060-45286-28	INS CVR 178×30 CU	2	
	060-45286-29	INS CVR 185×155	2	
	060-45286-30	INS CVR 60×6 CU	2	
	060-45382-12	CUSHION SHIELD 90×90	2	
	060-45286-31	INS CVR 3×341 AL	1	
	060-45396-01	BUSHING M3S	8	
	097-40217-10	WASHER M4	8	SPC MFCU2
	060-45286-32	CUSHION 102×20	1	ヒメロン T=0.7
	060-45286-33	CUSHION 8×6	8	ヒメロン T=0.7
	060-45473-01	INS CVR 4×270	4	DUBLE FACE TAPE
	060-45473-03	INS CVR 4×29	2	
	097-40216-52	SCR T-TITE M4×6 CU-P	3	

梱包関係部品表

記号	部品番号	部品名	個数	備考
1	019-38001-54	P.E BAG	1	P.E 0.03×150×250mm
2	060-23422-01	PACKING(L)	1	ピオセラン
3	060-23423-01	PACKING(R)	1	ピオセラン
4	019-47048-20	CARTON	1	
5	019-47048-21	MASTER CARTON	1	
6	060-45291X01	LABEL	5	
7	019-38002-17	P.E BAG	1	T0.04 POLTHN 250×350mm
8	060-23424X01	OWNERS MANUAL M08	1	
9	060-32170X01	CARD CONSUMER	1	
10	060-45292X01	LABEL OCR-TAN	1	
11	060-44804X01	ENVELOPE	1	
12	060-32171X01	CARD WARRANTY	1	
13	060-45317-01	PAD SHEET	1	
14	060-45318-01	PACKING SHEET	1	
15	012-41649-08	TIE 80MM	1	PVC BLACK

梱包図

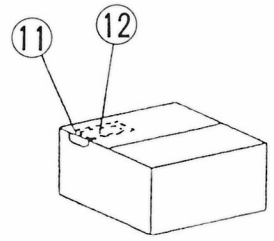
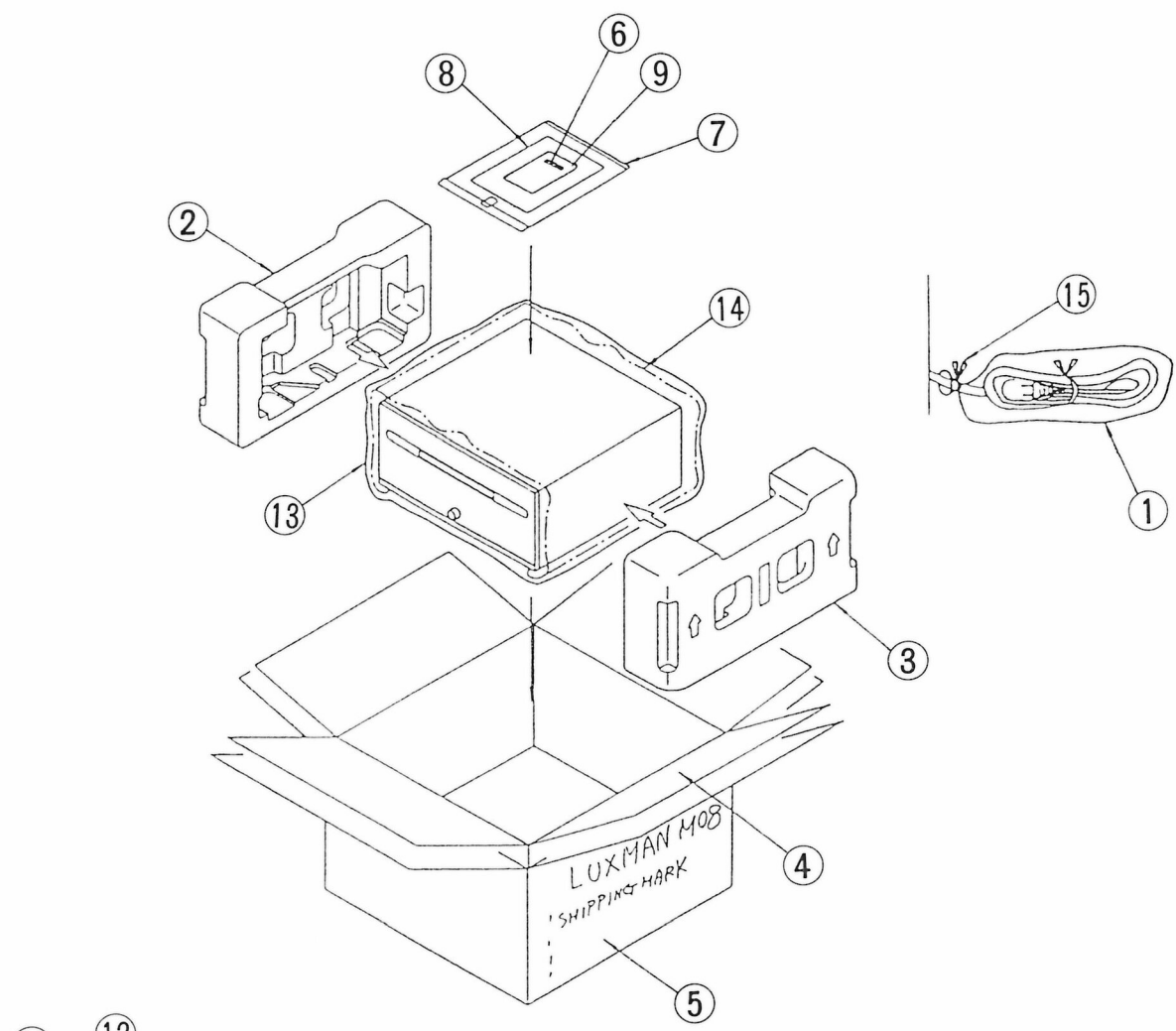

保証書

MODEL	M08
SERIAL NO	▨▨▨▨▨▨▨▨

10



LUX CORPORATION, JAPAN

10-27, 4-Chome, Higashi-Shinagawa, Shinagawa-ku, Tokyo 140, Japan
Tel: 03-5462-0405 Facsimile: 03-5462-0404