

SERVICE MANUAL

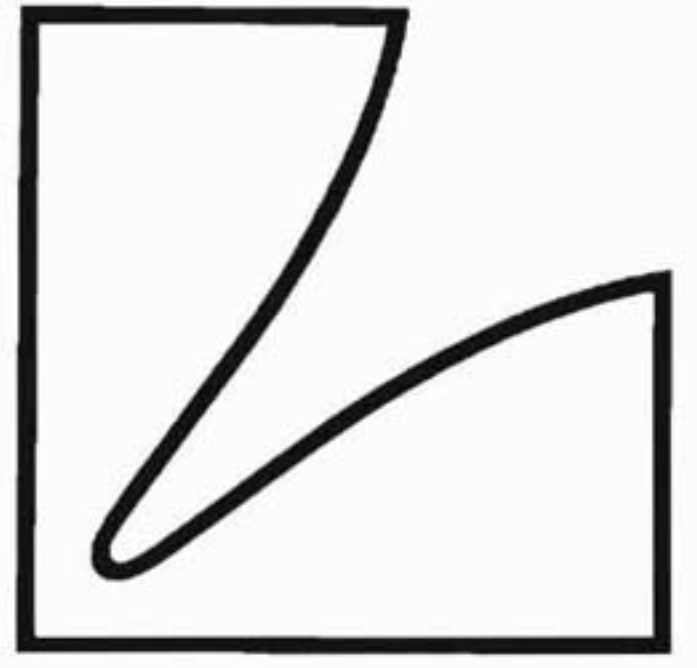

**DIRECT-DRIVE TURNTABLE
(WITHOUT CARTRIDGE) PD-272**



Control Circuit Operation

This control circuit works as a speed detector and is a F.G. (Frequency Generator) servo circuit which detects as a frequency the output of the generator rotating on the same shaft as the motor. Below we will explain the operation of each circuit part.

1) F.G. (Frequency Generator)

It is a winding and a multi-gap head with a 72 pole magnet and 36 pairs of teeth and generates a sine wave of 20Hz for 33-1/3 rpm and of 27Hz for 45 rpm.

2) Amplifier Circuit (1)

It amplifies the F.G. output and is constructed of a 2 stage differential amplifier circuit to obtain a dual cycle 50% square wave.

In order to double the frequency by the output of this circuit, adjust the semi-fixed resistor VR1 so the dual cycle of the square wave is 50%.

3) Frequency Step-up Circuit

Differentiate the inverted output and non-inverted output (along with the square wave) of the above mentioned amplifier circuit and obtain a fast rising and narrow differential pulse.

It adds each pulse to the switching transistors to get a saw tooth wave.

Each transistor turns ON the plus side by the pulse side by the pulse and step-up (2x) of the frequency is possible.

4) Saw Tooth Wave Generating Circuit

It consists of a charging circuit by CR and switching transistor which discharges in a short time the voltage charged in the condenser and produces a saw tooth wave having a wave height that is almost inversely proportional to the frequency.

5) Referenced Voltage Circuit

This is a circuit for obtaining the voltage to determine the speed of the motor. The resistance potential makes the source voltage which is the basic voltage.

In addition, in order to change the number of revolutions (rpm), it is constructed so the set voltage is varied continuously by/changing the potential ratio with a variable resistor.

6) Comparison Circuit

It consists of the differential comparison circuit and one switching transistor. It compares the level of the referenced voltage and the saw tooth wave shown in 4) and 5) and obtains an ON-OFF pulse. It operates so that when the height of the saw tooth wave is lower than the basic voltage-it is OFF and when higher it is ON. Frequency changes (number of rotation changes) are obtained as changes of the average of the output pulses.

7) Low-pass Filer

It flattens the comparison circuit output pulses and is constructed of 2-stage CR low-pass filter.

8) Amplifier Circuit (2)

This is a circuit to amplify the voltage impressed on the Hall element by the low-pass filter output.

9) Position Detector Circuit

Position detection (detects N pole and S pole of the rotor magnet) is done by the Hall element and determines the order of current flow in the 4 drive coils.

In addition, the voltage impressed on the Hall element/is controlled by the control circuit explained in 1) - 8) and the output voltage of the Hall element is changed in accord with the changes in number of revolutions.

10) Drive Circuit

It amplifies the output of the Hall element and makes current flow in the drive coils.

11) Feedback Circuit

It provides negative feedback to the amplifier circuit (2) from the drive circuit in order to stabilize operation.

Wave Form in Each Circuit (DC 20V)

1) F.G. output

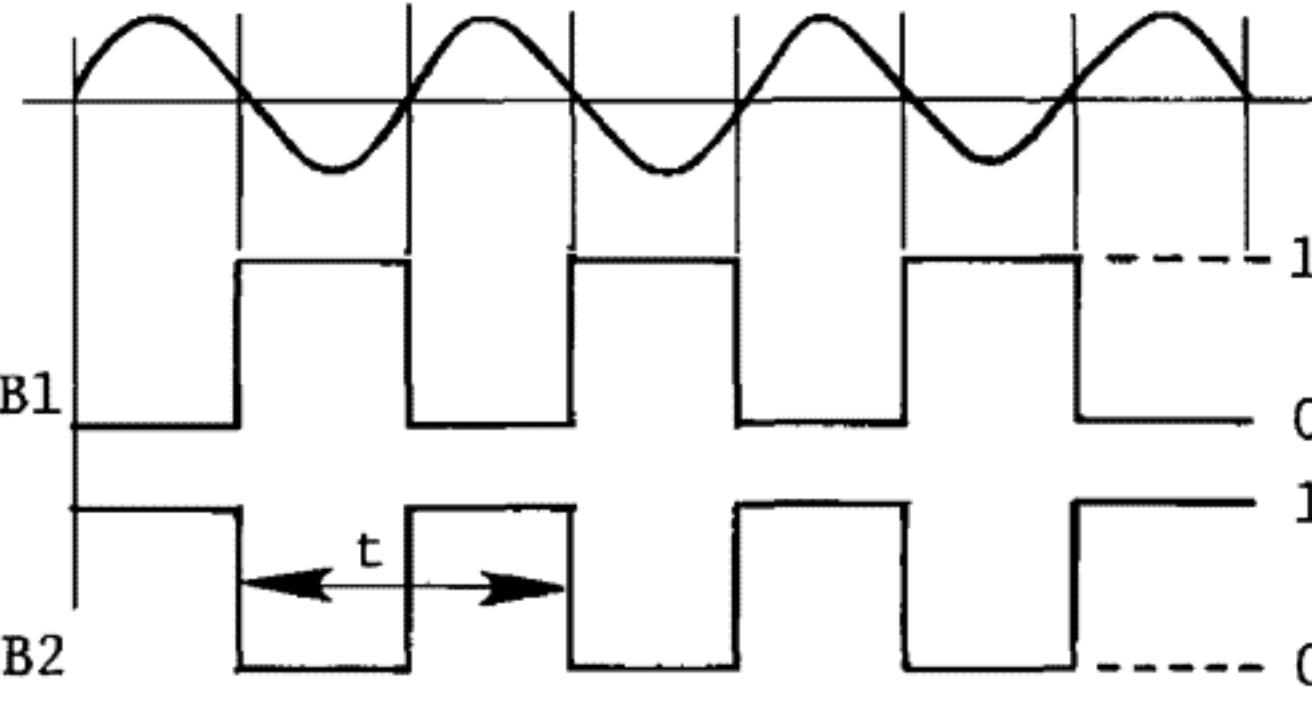

Lp 0.62Vp-p
Ep 0.84Vp-p

2) Amplifier
Circuit (1)
Inverted output

B1

B2



t = 50msec (Lp)
37.04msec (Ep)

Non-inverted
output

3) Frequency Doubling
Circuit

C1

C2

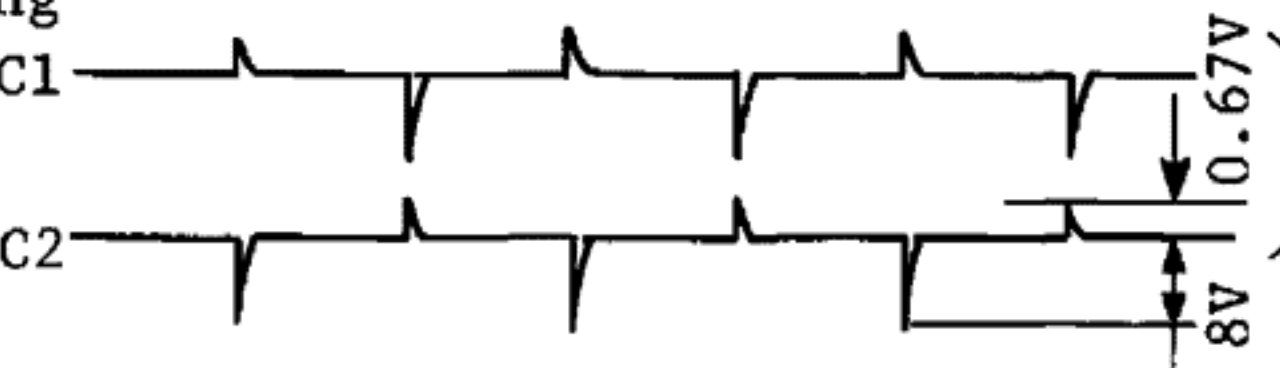

Differential output
wave form

4) Saw Tooth Wave
Generator Circuit

D



Lp; 4.6V
Ep; 3.6V

5) Basic Voltage

E

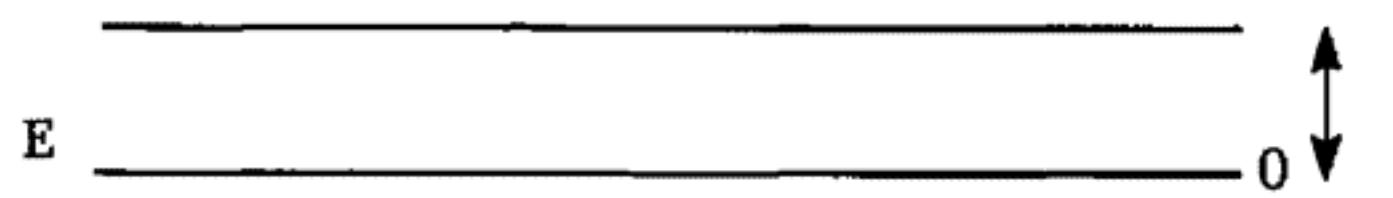

Lp; 4.6V
Ep; 3.6V

6) Comparison Circuit

F

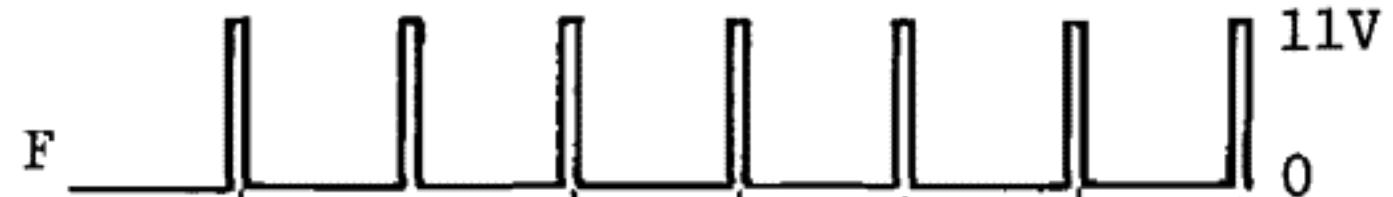

7) Low-pass Filter

G

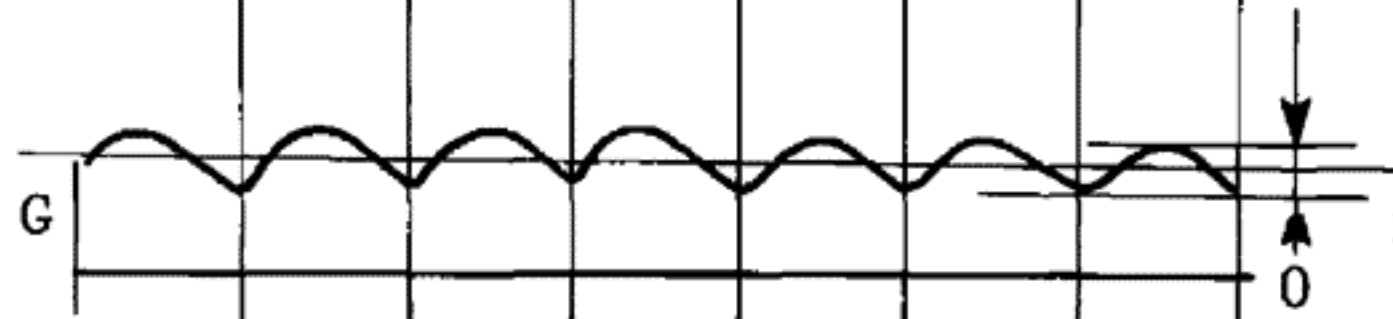

V=0.15V(Ep)
0.1V(Lp)

Hall element
output

H1

H2

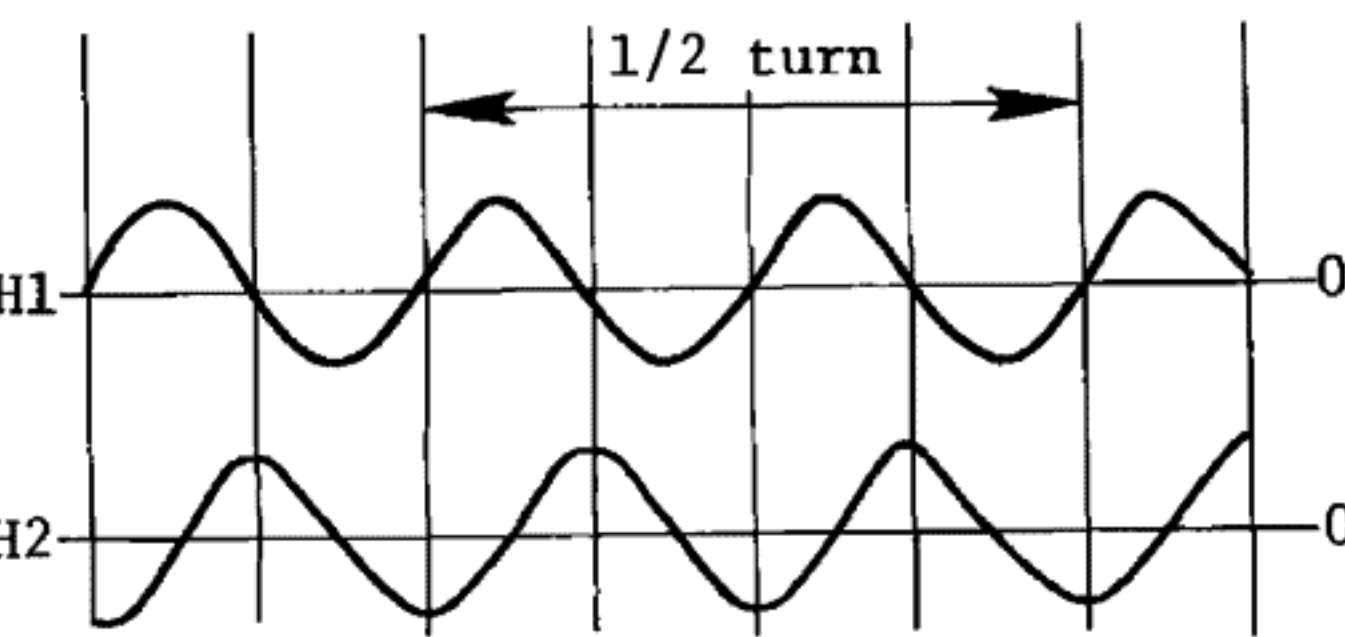

Approx. 0.2Vp-p

Circuit Adjustment Points

1) Adjustment of the frequency doubling circuit

Adjustment point VR₁ 330ΩB

Connect a synchroscope to No. 25 pin (GND) and No. 27 pin (+).

Good wave form

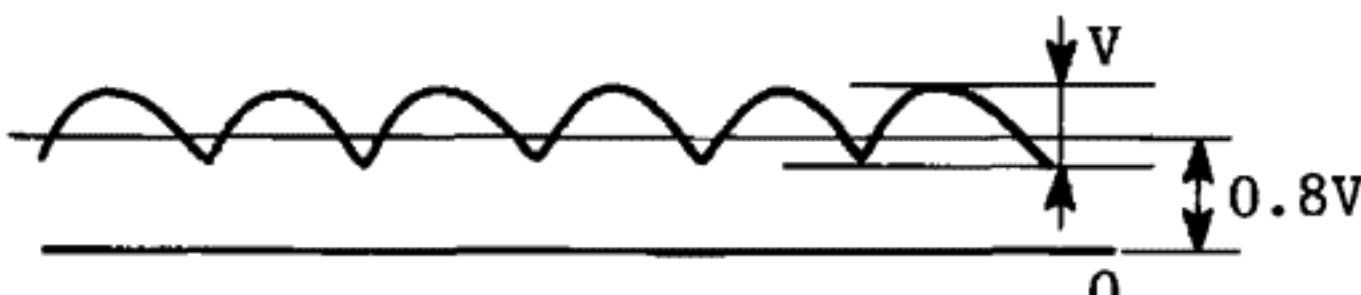

V=0.1V(Ep)
0.15V(Lp)

Bad wave form

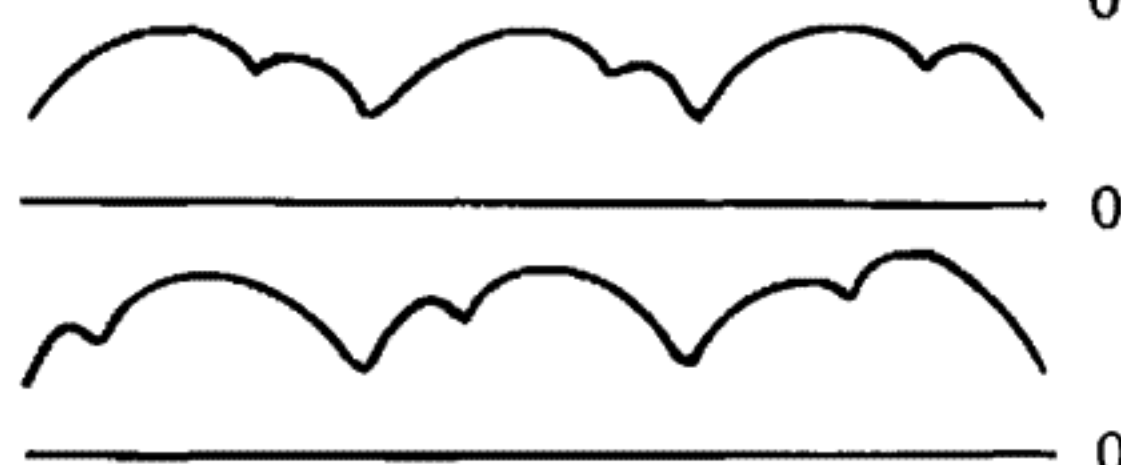

2) Drive Circuit Adjustment

a) Hall element adjustment

Adjustment point VR8 $330\Omega(B)$

Connect a synchroscope to No. 25 pin (GND) and No. 28 pin (+).

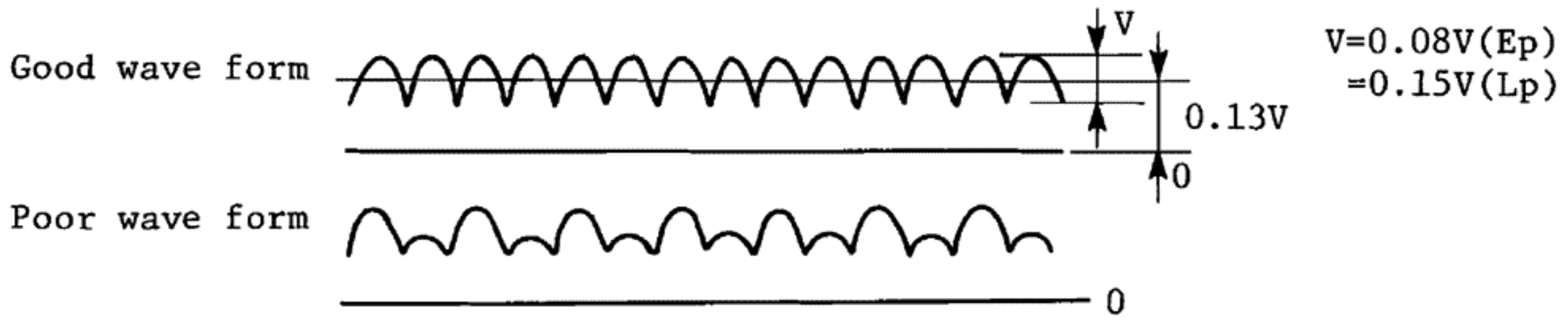

b) 4 coil current adjustment

Adjustment points VR6, VR7 ... $500\Omega(B)$

Good wave form Same as a).



3) RPM Adjustment

Set VR4, VR5 ($500\Omega B$) to the center and adjust to specified rpm with VR2, VR3

VR2 ... adjusts $33\frac{1}{3}$ rpm

VR3 ... adjusts 45 rpm

EXPLODED VIEW

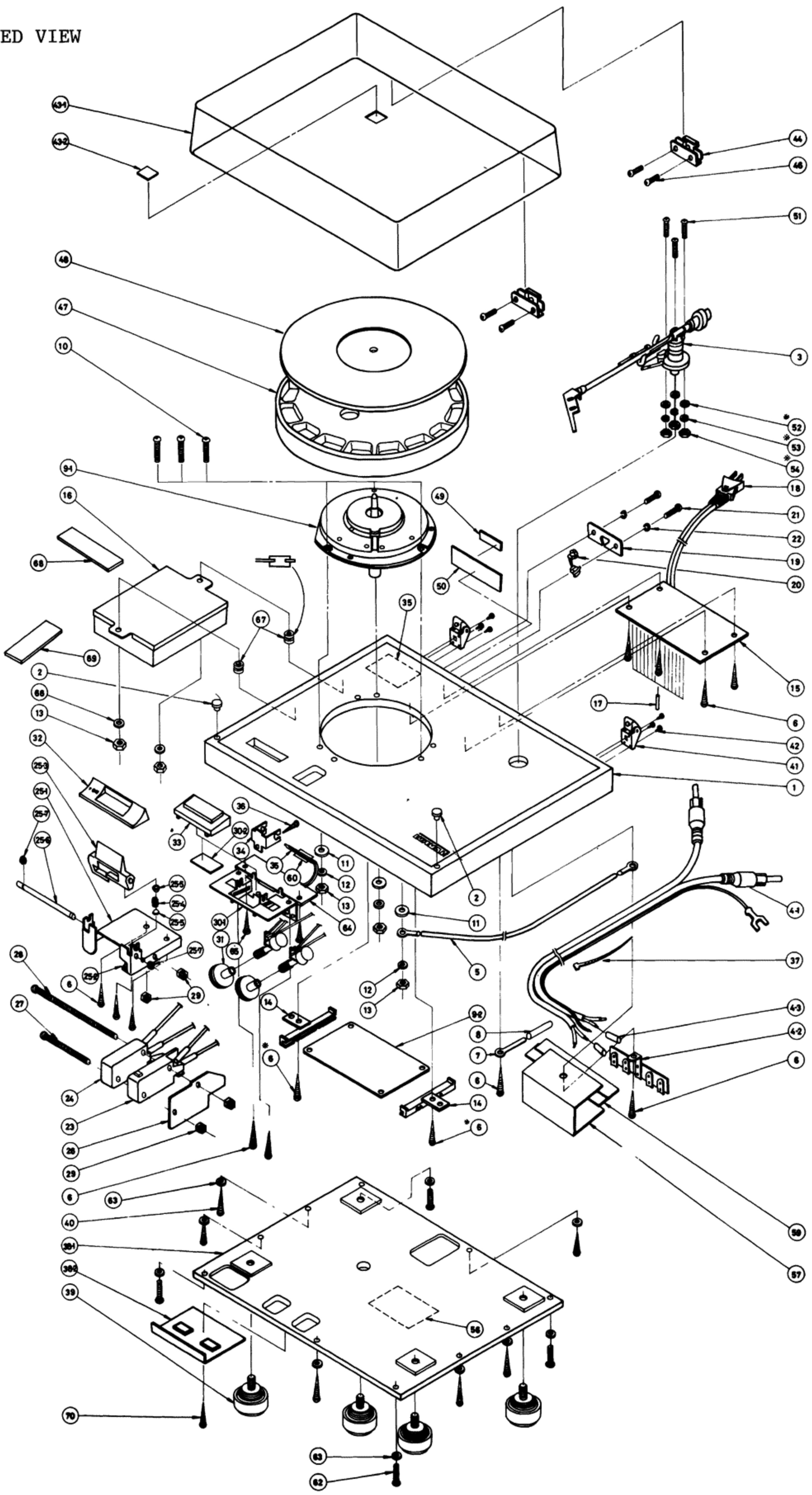

1.	846565	Cabinet	25-1.	870638	Switch Chassis
2.	892766	Cushion for Dust Cover	25-2.	894103	Spring Axle
3.	871406	Tone Arm Ass'y	25-3.	870637	Moulded Knob
4-1.	893699	Shielded Wire Ass'y	25-4.	894075	Spring
4-2.	D-10002-51	5P Lug Terminal	25-5.	894076	Spring Receptacle
4-3.		Tube(Varnish)	25-6.	893908	Switch Shaft
4-4.		UL Tape UL1007 TR64 AWG22	25-7.		EW2
5-1.		4 ϕ Terminal	26.	896175	Isolation Sheet
5-2.		3 ϕ Terminal	27.		FM \oplus 3x25
5-3.		UL Cord	28.		FM \oplus 3x60
6.		FMW \oplus 3.1x12	29.		FLN 3
7.	890755	Lug Terminal	30.	871366	Mirror Holder Ass'y
8.		Vinyl Tube 3 ϕ x60	30-1.	871309	Mirror Holder
9.	631446	Motor DDM-507 M-2	30-2.	896167	Reflection Plate
9-1.		Motor Ass'y DDF-507 M-2	31.	893907	VR Moulded' Knob
9-2.	631347	Circuit Ass'y	32.	871307	Switch Escutcheon
10.		FM \oplus 4x22	33.	896321	Strobo Escutcheon Ass'y
11.		FW 4.6 ϕ x12 ϕ x1t	33-1.	896176	Strobo Glass
12.		SSW 4	33-2.	871308	Strobo Escutcheon
13.		FLN 4	34.	893905	Lamp Holder
14.	896179	PCB Holder	35.	894001-3	Neon Lamp
15.	871120-1	Power Supply Ass'y	36.		\oplus Self-tap Screw
16.	871363	Power Transformer	37.	894408	Wire Fastener
17.	702233-3	UL Tube	38.	871367	Bottom Plate Ass'y
18.	890208-2	AC Cord	38-1.	851312	Bottom Plate
19.	893037	AC Cord Stopper	38-2.	871310	Plate for Speed Fine Control
20.	891568-2	SR Bushing	39.	894473	Leg
21.		BM \oplus 3x14	40.		FMW \oplus 3.1x16
22.		SW 3	41.	893020	Hinge Plate Ass'y
23.	896177	Micro SW Cord Ass'y	42.		BMW \oplus 3.1x12
23-1.	870560	Micro SW	43.	851357	Dust Cover
23-2.		UL Cord	44.	893018	Lock Plate
23-3.		UL Cord	45.	896288	Lock Plate Spacer
17.	702233-3	UL Tube 3.7 ϕ x15	46.		FM \oplus 3x8
24.	871364	VR Micro SW Ass'y	47.	620028	Platter
24-1.	871391	Micro Switch	48.	871410	Platter Mat
24-2.	703062	VR 500ohms-R	49.	892239	Number Label
24-3.	871358	Connector Ass'y	50.	896258	Number Label
24-4.		UL Cord	51.		BsM 3x28
24-5.		UL Cord	52.		FW 3.2 ϕ x10 ϕ x1t
17.	702233-3	UL Tube	53.		SW 3
25.	894168	Switch Chassis Ass'y	54.		FLN 3

SYMBOL NO.	STOCK NO.	DESCRIPTION	LOCATION
R1		12KΩ 1/4W	
2		8.2K "	
3		220 "	
4		220 "	
5		120 "	
6		120 "	
7		12K "	
8		2.2K "	
9		2.2K "	
10		56K "	
11		2.2K "	
12		2.2K "	
13		56K "	
14		5.6K "	
15		5.6K "	
16		470K "	
17		12K "	
18		12K "	
19		22K "	
20		1.5M "	
21		4.7K "	
22		5.6K "	
23		6.8K "	
24		4.7K "	
25		12K "	
26		3.9K "	
27		33K "	
28		12K "	
29		1K "	
30		5.6K "	
31		330 "	
32		100 "	
33		22K "	
34		22K "	
35		22K "	
36		22K "	
37		2.7K "	
38		2.7K "	
39		4.7 2W	
40		2.2K 1/4W	
41		10K "	
42		10K "	
C1		0.1 50V M	
2		0.01 50V M	
3		0.01 50V M	
4		0.1 50V M	
5		1 16-50V E	
6		1 16-50V E	
7		0.47 16-50V E	
8		100 25V E	
9		1 16-50V E	
10		1 16-50V E	
11		1 16-50V E	
12		1 16-50V E	

M; mylar film
E; electrolytic

SYMBOL NO.	STOCK NO.	DESCRIPTION	LOCATION
VR1		330 (B)	
2		5K (B)	
3		5K (B)	
4		500 (B)	
5		500 (B)	
6		500 (B)	
7		500 (B)	
8		330 (B)	

Semiconductors

- X1, X2, X9 2SA641, 2SA842 or 2SA564
- X3~X8, X10, X16~X19
..... 2SC945, 2SC733,
..... 2SC1815 or 2SC828
- X12~X15 2SA733 or 2SA561
- X20~X24 2SD571 or 2SC1384
- X11 2SB605, 2SA684 or 2SA886
- D1 MV203V
- D2, D3 1S953, 1SS53 or MA150
- D4 SIRBA10
- ZD1 RD13E(B) or MA1130

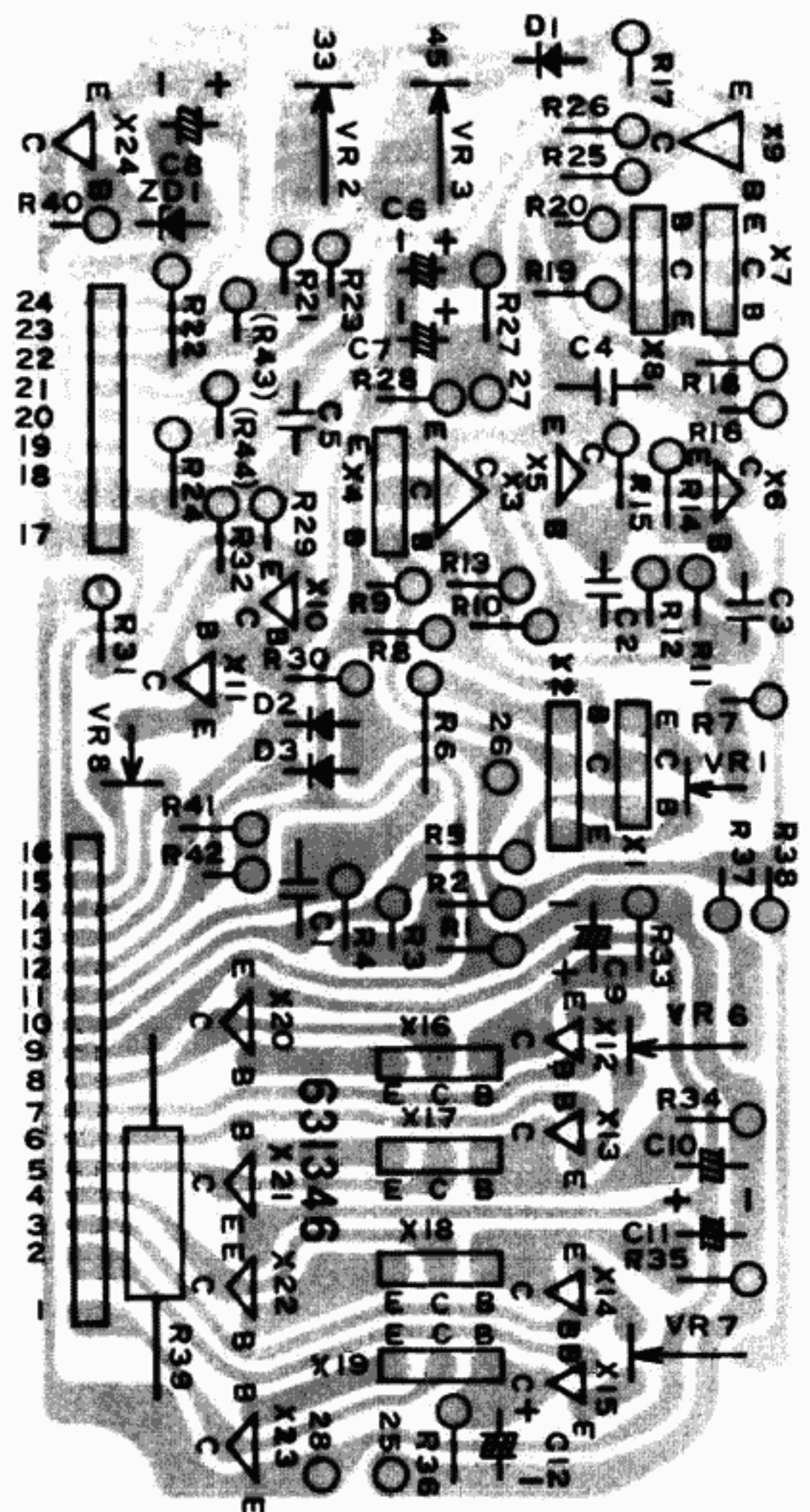

SPECIFICATIONS

[Phono Motor Section]

Driving System:	Direct-Drive System
Motor:	DC-servo brushless & slotless motor
Turntable Platter:	30cm aluminium die-cast (weight 1.8kgs including platter-mat)
Rotation:	33-1/3 rpm, 45 rpm (2-speed)
Adjustable Range of Rotation:	±4%
S/N Ratio:	No less than 60dB (IEC-B)
Wow & Flutter:	no more than 0.03% W.R.M.S.

[Tonearm Section]

Tonearm:	Straight Arm of static balance type
Effective Length:	240mm
Tracking Error:	+2°13', -1°08'
Overhang:	15mm
Cartridge Weight:	4g – 11g
Cartridge Height:	13.5mm – 20.5mm
Stylus Pressure:	0 – 3g (direct reading)
Accessories:	Anti-skate Adjustment, Tonearm Elevation

[Additional Features]

Dust Cover:	Detachable with semi-freestop hinge
Insulator:	Height adjustable
Stroboscope:	Mirror-reflex type.

[General]

Power Consumption:	5W
Dimensions:	472(W) x 152(H) x 348(D)mm (18-37/64" x 6" x 13-45/64")
Weight:	Net 10kgs (22 lbs.) Gross 12kgs (26.4 lbs.)

Downloaded from www.vinylengine.com

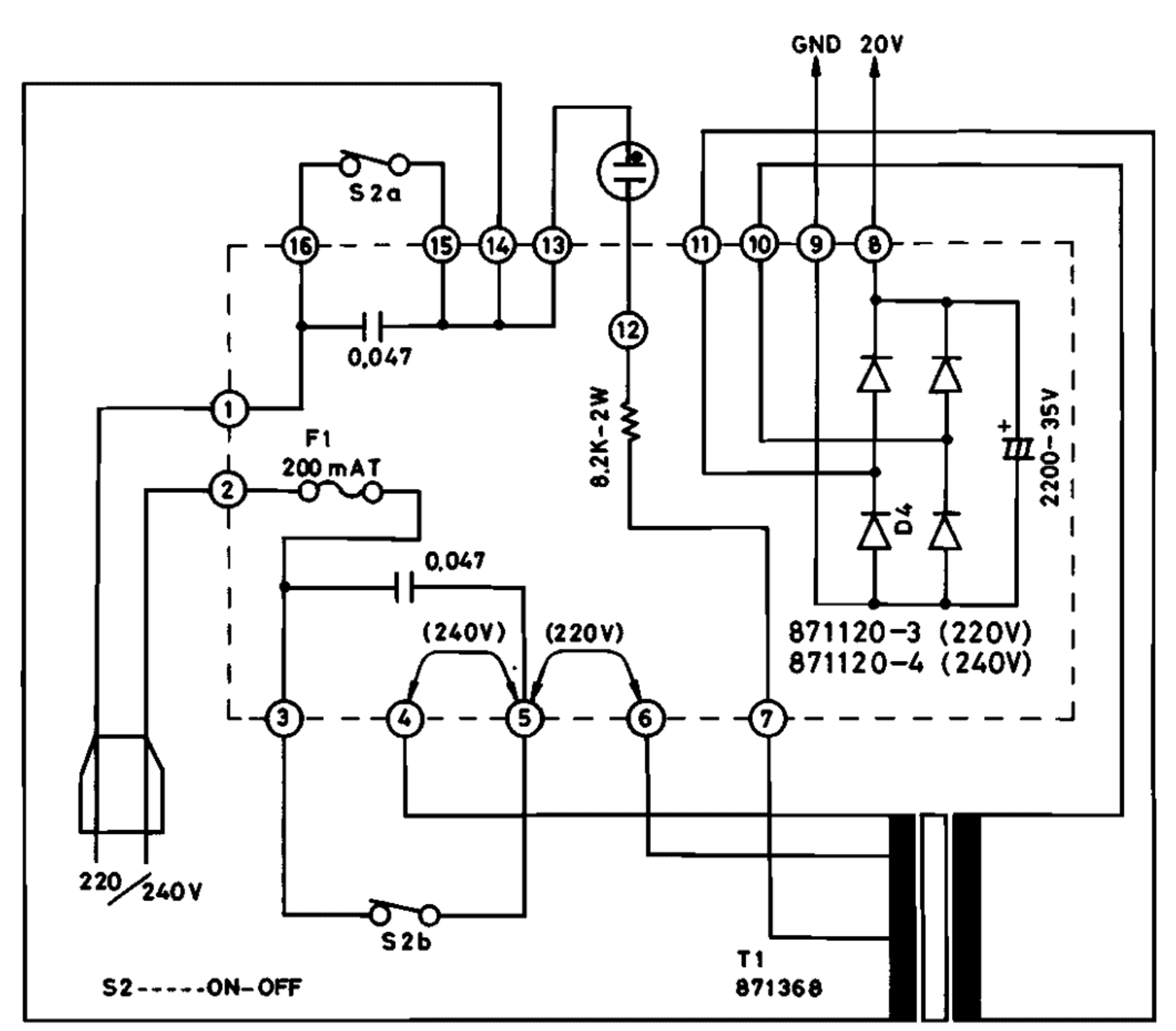
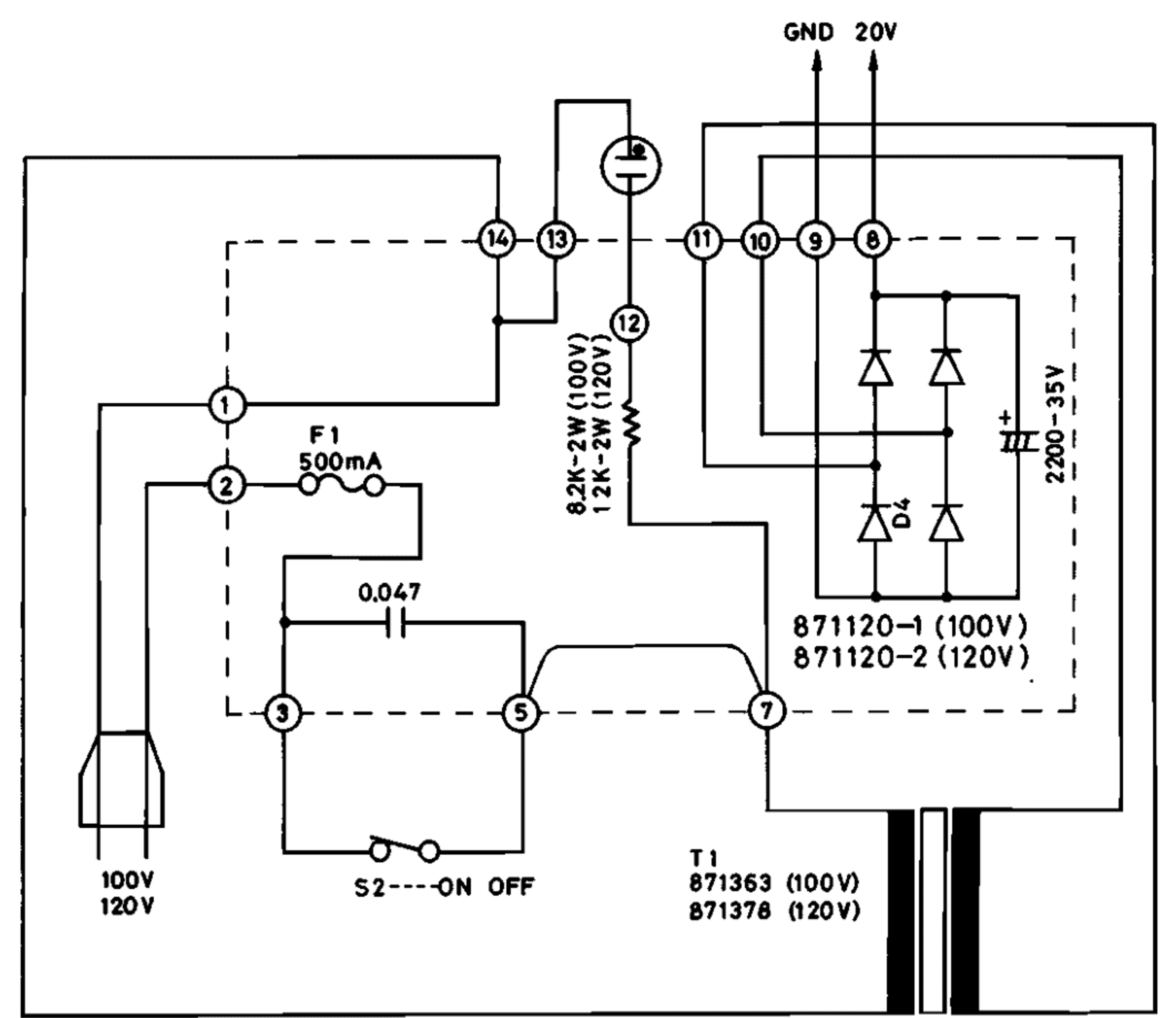
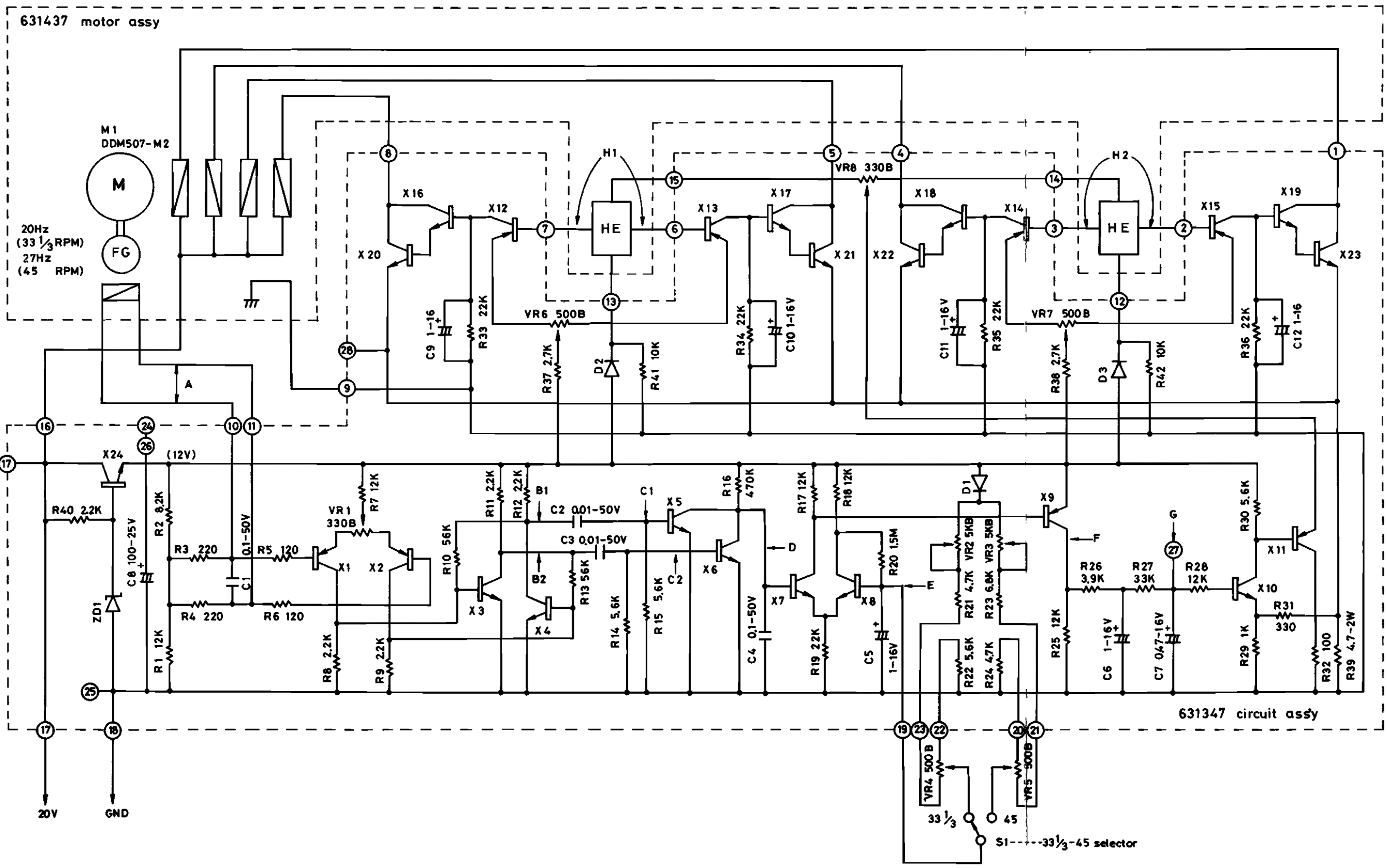

- X1, X2, X9 -----2SA641, 2SA842 or 2SA564
- X3~X8, X10, X16~X19-----2SC945, 2SC733, 2SC1815 or 2SC828
- X12~X15 -----2SA733 or 2SA561
- X20~X24 -----2SD571 or 2SC1384
- X11 -----2SB605, 2SA684 or 2SA886
- D1 -----MV203V
- D2, D3 -----1S953, 1SS53, MA150 or 1S1555
- D4 -----S1RBA10
- ZD1 -----RD13E(B) or MA1130

1. Unless otherwise specified, all resistors are in ohm $\frac{1}{4}$ watt, all capacitors are in micro-farad.
2. Transistors and diodes may be replaced with any types having comparable ratings.
3. Due to continued improvements LUX reserve the right to alter the circuit or specification

LUX CORPORATION, JAPAN

1-1, 1-CHOME, SHINSENRI-NISHIMACHI, TOYONAKASHI, OSAKA
PHONES:06-834-2222 CABLE:LUXELECT OSAKA TELEX.J63694



LUX Audio of America Ltd.

EXECUTIVE OFFICES

160 Dupont Street • Plainview, New York 11803 • (516) 822-7070

April 26, 1978

TO: ALL LUX SERVICE STATIONS

SUBJECT: PD-272

We have been alerted that there has been an occasional problem of hum on the Lux PD-272. Upon careful analysis, we determined that this hum is being caused by the power transformer.

It is not necessary to change the transformer nor will tightening laminations be of any help. Proper protective procedure is:

1. Remove the bottom cover of the unit.
2. Remove the two screws holding down the transformer.
3. Enlarge the mounting holes from the transformer by 3/32".
4. Remove the backing from the adhesive sponge and place the transformer so it lies between the transformer and the inside of the base.
5. Insert the rubber bushings into each of the two mounting holes and reassemble the transformer onto the base.

Enclosed is a supply of rubber bushings which are necessary for this modification.

If there are any questions, please do not hesitate to contact me immediately.

Sincerely,

Richard Kawatani
Sales Technician

RK:sm
cc: All Lux Representatives

Enc.

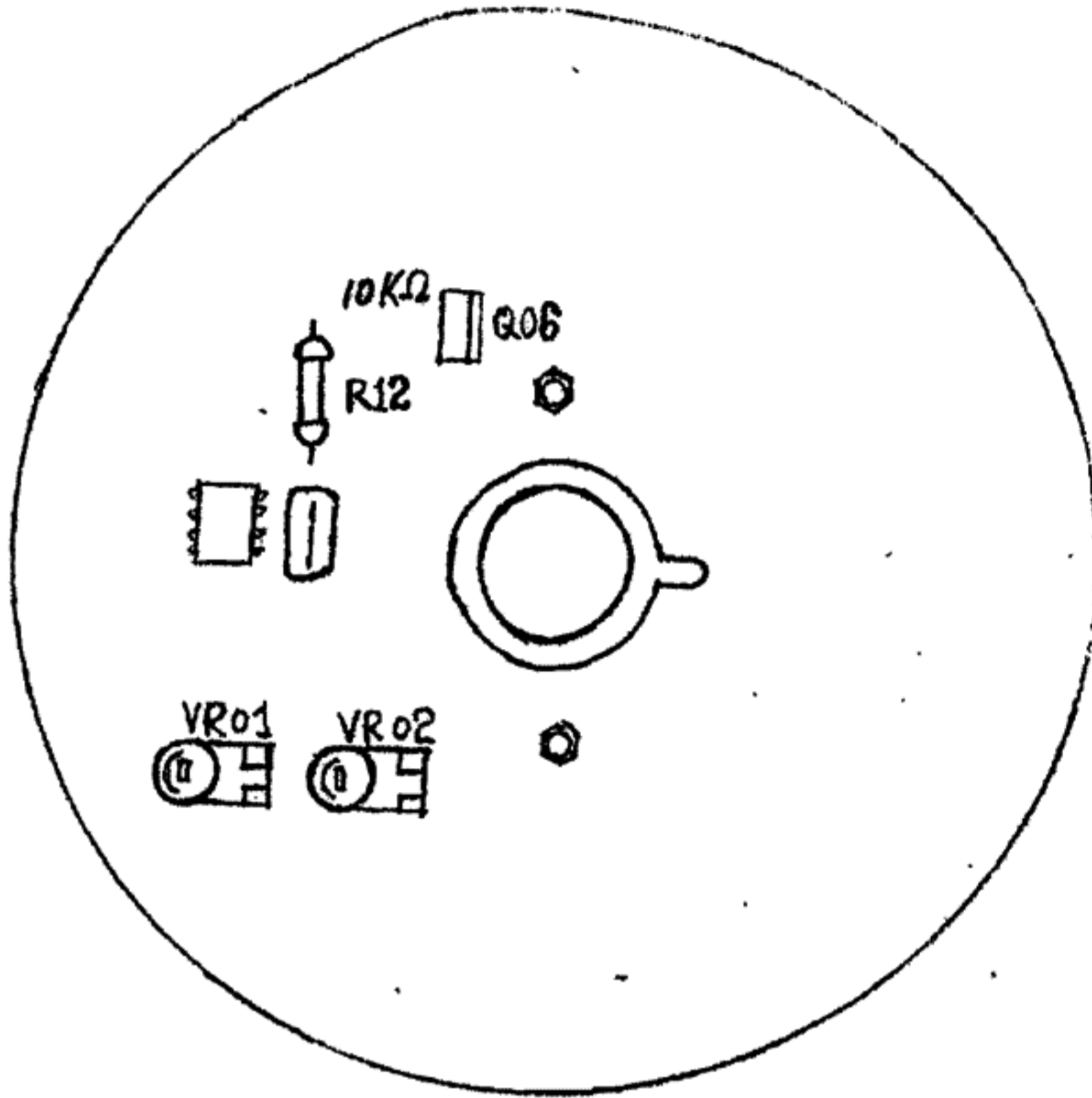

PD-272

Tonearm

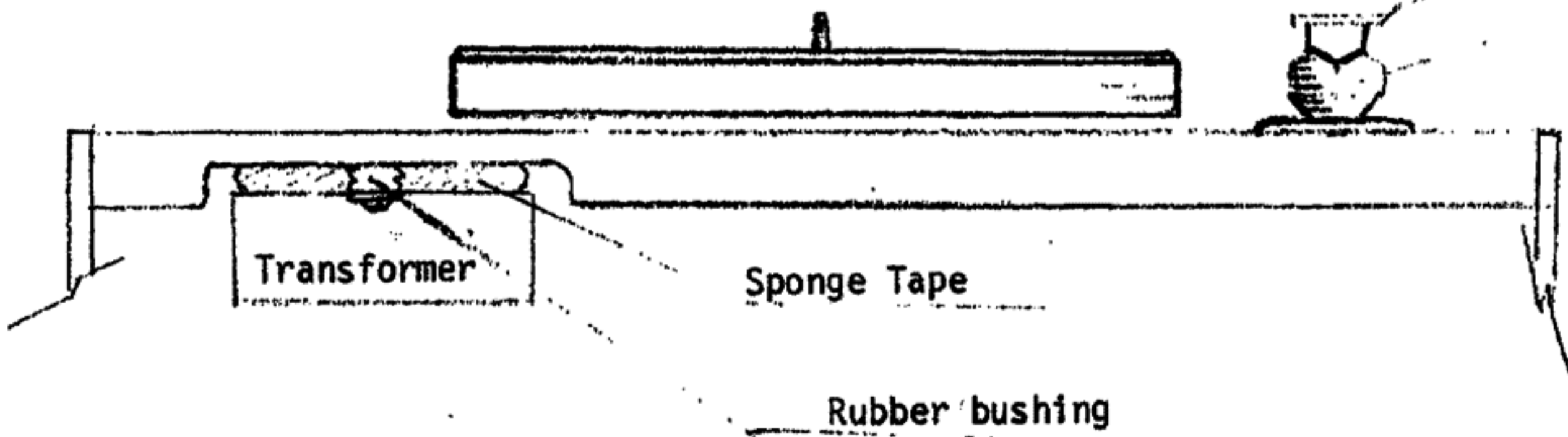

Transformer

Rubber Bushing

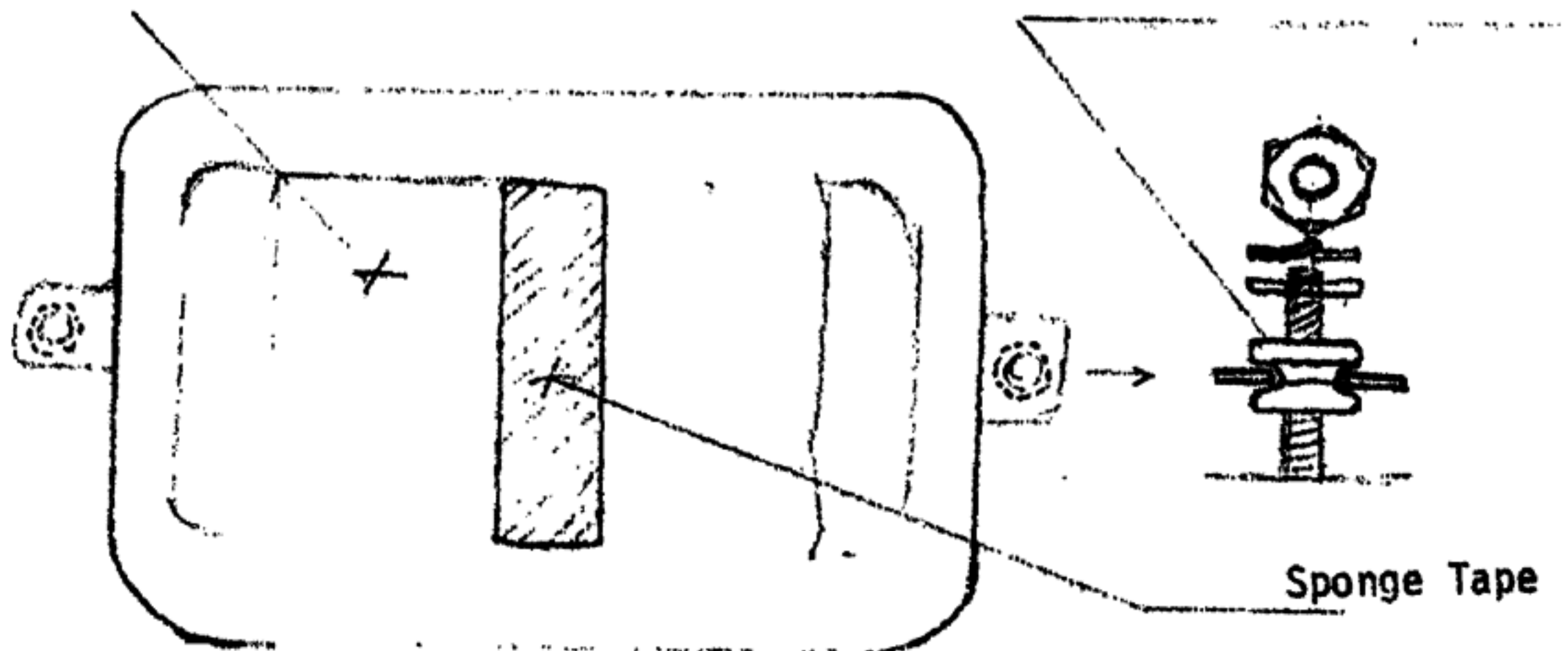

Sponge Tape