

SERVICE MANUAL

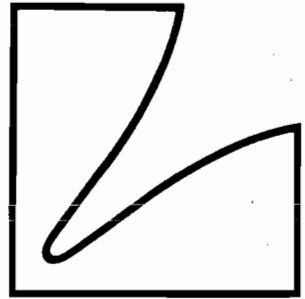

VACUUM DISC STABILIZER TURNTABLE **PD300**

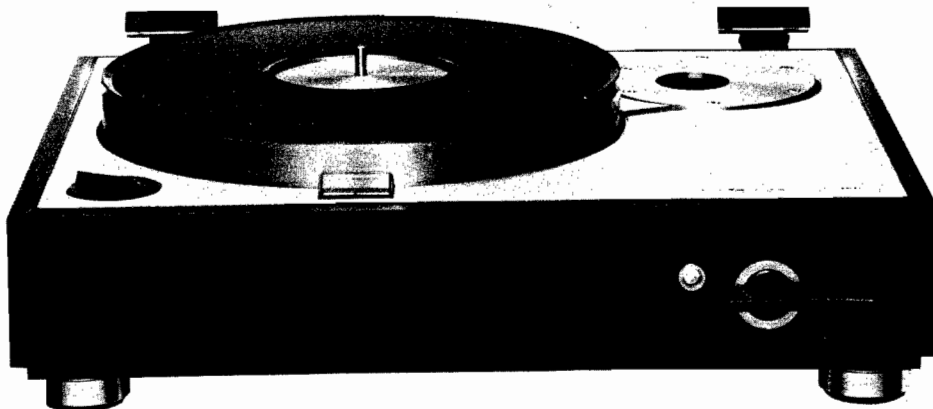

CONTENTS

Adjustment Procedures	2
Cautions	2
Exploded View	3
Exploded View Parts List	4
PB-1344 Parts List	5
PB-1344-1 Parts List	5
Motor PCB Parts List	6
Specifications	6
Schematic Diagram	7

ADJUSTMENT PROCEDURES

Adjustment of Rotation

Set the speed adjustment knob at the mechanical center position for both 33 and 45 r.p.m. respectively, and adjust the VR2 (33 r.p.m.) and VR3 (45 r.p.m.) in the motor control P.C.B. so that the stroboscope gets statinary.

Adjustment locations

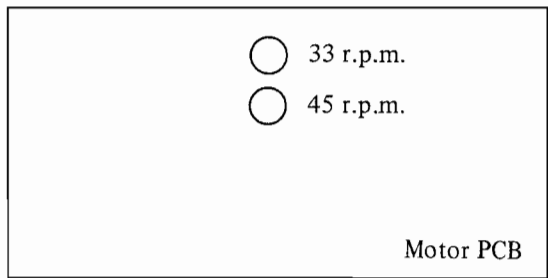

CAUTIONS

1. Turn table etc. should be kept always clean.

The vacuum disc stabilizer system provides unprecedented performance, but it offers quite delicate characteristic at the same time. Record disc, surface to the turntable platter and the sealing pad should be kept always clean. Especially it is advisable to clean the surface of the platter and, of course, the record disc before performing reproduction.

2. Be careful about deformation of the sealing pad.

The sealing pad plays an important role to integrate the record disc and turntable platter and kept the condition for a long period. Never put anything on the sealing pad to deform it, air suction may become impossible.

The sealing pad is detachable. Consult your nearest LUXMAN dealer for replacement parts when it goes wrong.

REMARKS

In this manual the parts, which differs depending on destination and mains voltage, are classified and indicated as follows:

- J: 100V for Japan
- A — { AZ: 120V (With Line Voltage Selector) for U.S.A., South Asia, East Asia
- AK: 220V (With Line Voltage Selector) for Europe, South Asia, East Asia
- AG: 240V (With Line Voltage Selector) for England, Australia

EXPLODED VIEW

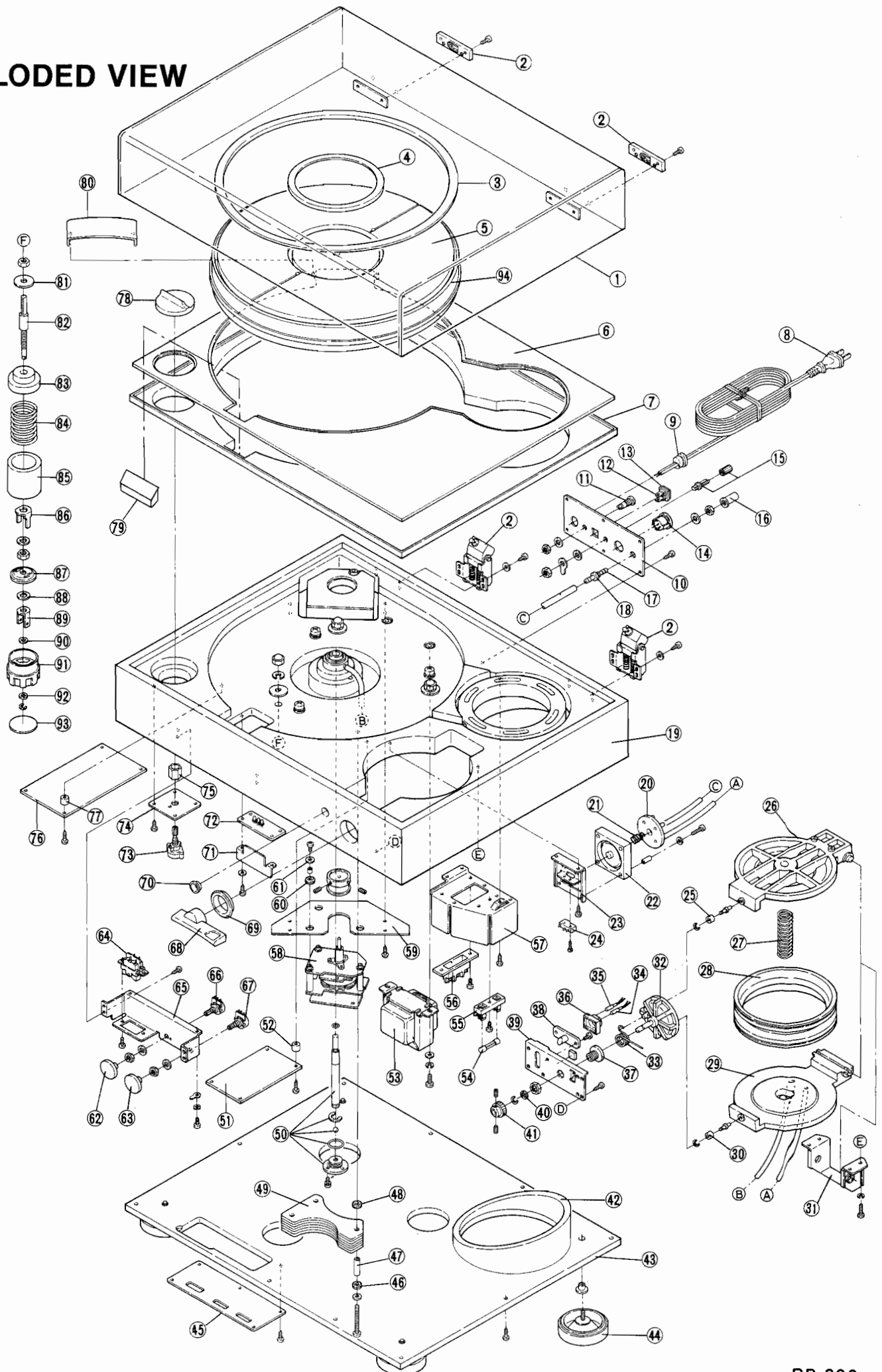

EXPLODED VIEW PARTS LIST

Symbol No.	Stock No.	Description	Symbol No.	Stock No.	Description
1	WZ1122	Dust Cover	51		PB-1344 Ass'y
2	UZ1091	250 Auto Hinge	52	UW1129	Spacer
3	UN1031-E	Sealing Pad (out)	53	PT2504	Power Trans P-2504 (J)
4	UN1032-E	Sealing Pad (in)		PT2507	Power Trans P-2507 (A)
5-1	UZ1224	Turn Table	54	BF0112	Fuse NR60NR-0.75A (J)
5-2	UZ1241	Oil Seal VDS		BF0202	Fuse 5 x 20 0.2A (T)(AZ)
5-3	UN1034	Seal Rubber		BF0201	Fuse 5 x 20 0.1A (T)
6	WA1218-1	Panel (J)			(AK, AG)
	WA1218-2	Panel (AZ, AK, AG)	55	AH0016	Fuse Holder (J)
7	UN1027	Base Rubber		AH0019	Fuse Holder (A)
8	BK0015	AC Cord (J)	56	AT0069	Terminal Plate
	BK0018	AC Cord (AZ)	57	UR1299	Bracket
	BK0022	AC Cord (AK)	58	AM1007	Motor PHM-6102F-01
	BK0023	AC Cord (AG)	59	UR1314	Motor Bracket
9	BU0033	Cord Stopper (J,AZ,AK)	60	UN1029	Motor Bushing
	BU0039	Cord Stopper (AG)	61	UZ1223	Motor Washer
10	UC1194-1	Rear Panel (J)	62	WJ1062	Mold Knob 33rpm
	UC1194-2	Rear Panel (A)	63	WJ1062	Mold Knob 45rpm
11	AL0001	Neon Lamp (J)	64	SE0009	Power Switch (J)
12	UZ1245	LPS Terminal (J)		SE0008	Power Switch (A)
13	UZ1244	LPS Housing (J)	65	UR1294	Bracket
14	AS5016	Connector Socket	66	RV0274	Semi-Fixed
15	AG0063	GND Terminal			K161108S-2KB
16	WK1132	Metal Cap	67	RV0274	Semi-Fixed
17	UZ1247	Rubber Bushing			K161108S-2KB
18	UZ1234	Air Joint	68	WJ1144	Mold Knob VDS Lever
19	WB1087-1	Cabinet (J)	69	WK1129	Metal Ring
	WB1087-2	Cabinet (A)	70	WK1130	Indicator Metal
20	UZ1235	Bellows Housing	71	UL1008	Masking Plate
21	UU1037	Return Spring	72		PB-1344 Ass'y
22	UZ1233	Indicator Bellows	73	SR0150	Rotary SW. Speed
23	UR1306	Bracket	74	UR1309	Fixing Metal
24	SP0180	Micro SW SS-1E4	75	UZ1218	Knob Nut
25	UZ1214	Roller	76		Motor PCB Ass'y
26	UZ1208-1	Pump Shell	77	UW1129	Spacer
27	UU1034	Pump Spring	78	WJ1151	Mold Knob
28	UZ1209	Bellows	79-1	WD1033	Escutcheon
29	UZ1208-2	Pump Shell	79-2	UW1128	Spacer
30	UZ1214	Roller	79-3	UM1006	Reflection Plate
31	UR1298	Bracket	79-4	UL1009	Masking Plate
32	UZ1210	Cam	80-1	WE1094	Protector
33	UU1035	Cam Spring	80-2	WZ1117	Stopper Pin
34	AL0043	Lamp 12V-75mA	81	UZ1239	Flat Washer
35	AL0043	Lamp 12V-75mA	82	UZ1226	Insulater Shaft
36	WZ5056	Lamp Holder	83	UZ1225	Insulater Rubber
37	UZ1213	Cam Bearing	84-1	UU1047	Insulater Spring
38	WG1017	Indicator Acryl	84-2	UU1036	Insulater Spring
39	UR1295	Bracket	85	UZ1249	Urathane Form
40	UZ1230	Thrust Washer	86	UZ1228	Stopper
41	UZ1242	Knob Ring	87	UZ1229	Fixing Metal Spring
42	UZ1250	Urethane Form	88	UZ1231	Thrust Washer
43	UE1108	Bottom Plate	89	UZ1227	Nut
44	WZ1120	Insulater Rubber	90	UZ1230	Thrust Washer
	WN1020	Metal Foot	91	WJ1150	Mold Knob
45	WL1105	Name Plate	92	UZ1230	Thrust Washer
46	BU0056	Bushing	93	WL1104	Name Plate
47	UW1130	Spacer	94	UZ1236	Belt Drive
48	BU0056	Bushing	A	UZ1246-1	Air Tube
49	UZ1232	Weight	B	UZ1246-2	Air Tube
50	UZ1237	Bearing	C	UZ1246-3	Air Tube

PB-1344 PARTS LIST

PB-1344

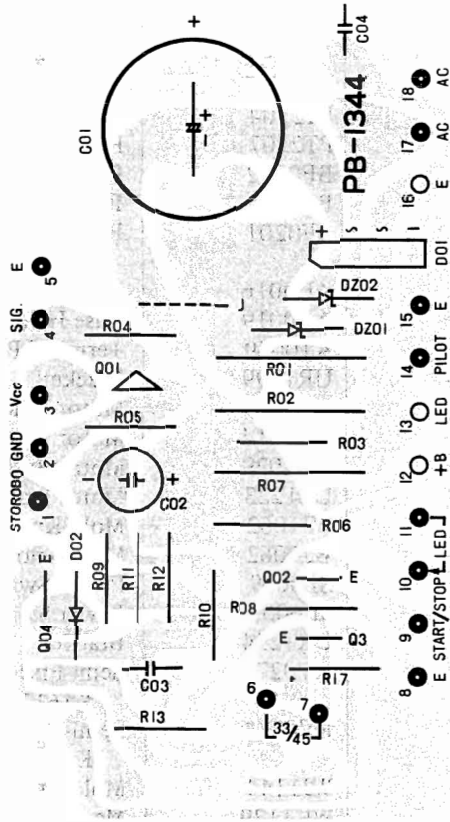

Symbol No.	Stock No.	Description
(Transistor)		
Q01	TR0228	2SB435
Q02	TR0029	2SC945
Q03	TR0029	2SC945
Q04	TR0029	2SC945
(Zener Diode)		
DZ01	TD0220	BZ-050
DZ02	TD0220	BZ-050
(Diode)		
D01	TD0139	SIVB20
D02	TD 003	1S1583
(Capacitor)		
C01	CE1452	6800 μ F 25WV E1
C02	CE1703	22 μ F 6.3V E1
C03	CQ1325	0.1 μ F 50WV My
(Resistor)		
R01	RS2568L	220 2WV Ro
R02	RS2568L	220 2WV Ro
R03	RD2590	2.2K 1/2WV Rd
R04	RD0453	12K 1/4WV Rd
R05	RD0464	1.5K 1/4WV Rd
R06	RS5028	1.2K 1WV Ro
R07	RS2568L	220 2WV Ro
R08	RD0452	15K 1/4WV Rd
R09	RD0446	47K 1/4WV Rd
R10	RD0444	68K 1/4WV Rd
R11	RD0455	8.2K 1/4WV Rd
R12	RD0441	120K 1/4WV Rd
R13	RD0449	27K 1/4WV Rd
R14	RD0448	33K 1/4WV Rd

PB-1344-1 PARTS LIST

Symbol No.	Stock No.	Description
(L.E.D.)		
LED01	TD0219	BR5505S
LED02	TD0219	BR5505S
LED03	TD0219	BR5505S

PB-1344-1

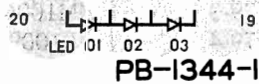

Motor PCB

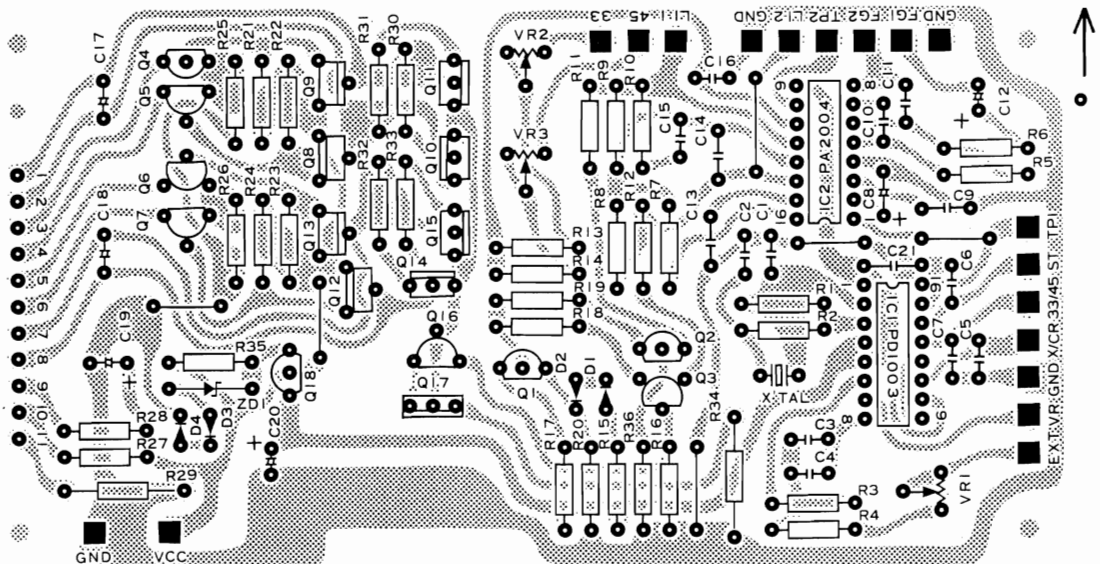

MOTOR PCB PARTS LIST

Symbol No.	Stock No.	Description
(I.C.)		
IC-1	TCQ0036	PD1003
IC-2	TCQ0037	PA2004
(Transistor)		
Q1	TR0043	2SA733 P, Q
Q2	TR0043	2SA733 P, Q
Q3	TR0043	2SA733 P, Q
Q4	TR0029	2SC945 P, Q
Q5	TR0029	2SC945 P, Q
Q6	TR0029	2SC945 P, Q
Q7	TR0029	2SC945 P, Q
Q8	TRQ2011	2SA673 B, C
Q9	TRQ2011	2SA673 B, C
Q10	TR0277	2SC1213 B, C
Q11	TR0277	2SC1213 B, C
Q12	TRQ2011	2SA673 B, C
Q13	TRQ2011	2SA673 B, C
Q14	TR0277	2SC1213 B, C
Q15	TR0277	2SC1213 B, C
Q16	TR0029	2SC945 P, Q
Q17	TRQ4022	2SC1449 L, M
Q18	TR0029	2SC945 P, Q
(Capacitor)		
C1	CC0014	22pF 50WV El
C2	CC0014	22pF 50WV El
C6	CK0067	0.01μF 50WV Ce
C7	CK0067	0.01μF 50WV Ce
C8	CS0056	0.1μF 50WV Ta
C9	CQ0153	0.039μF 50WV My
C10	CC0046	680pF 50WV Ce
C11		0.015μF 50WV Ce
C12	CE0025	10μF 10WV El
C13	CK0067	0.01μF 50WV Ce
C14	CQ0148	0.01μF 50WV My
C15	CQ0154	0.056μF 50WV My
C16	CK0067	0.01μF 50WV Ce
C17	CE0085	33μF 25WV El
C18	CE0085	33μF 25WV El
C19	CE0145	100μF 25WV El
C20	CE0054	47μF 16WV El
C21	CK0067	0.01μF 50WV Ce

Symbol No.	Stock No.	Description
(Varistor)		
D1	TVQ0001	VD1222
D2	TV0015	VD1122
D3	TVQ0001	VD1222
D4	TVQ0001	VD1222
(Crystal)		
X-TAL	TXQ0002	LSS-002-0
(Zener Diode)		
ZD1	TDQ0232	RD9. 1EB2
(Semi-Fixed Resistor)		
VR2		10K
VR3		6.8K
(Resistor)		
R1	RC0338	4.7M 1/4WV Rd
R2	RC0249	1K 1/4WV Rd
R5	RC0306	220K 1/4WV Rd
R6	RC0231	220 1/4WV Rd
R8	RC0300	120K 1/4WV Rd
R9	RC0290	47K 1/4WV Rd
R10	RC0274	10K 1/4WV Rd
R11	RC0274	10K 1/4WV Rd
R12	RC0274	10K 1/4WV Rd
R13	RC0282	22K 1/4WV Ro
R14		16K 1/4WV Ro
R15	RC0233	270 1/4WV Rd
R16	RD0305	2.4K 1/4WV Rd
R17	RC0251	1.2K 1/4WV Rd
R18	RD0055	120 1/4WV Rd
R19	RD0055	120 1/4WV Rd
R20	RC0261	3.3K 1/4WV Rd
R21	RC0251	1.2K 1/4WV Rd
R22	RC0251	1.2K 1/4WV Rd
R23	RC0251	1.2K 1/4WV Rd
R24	RC0251	1.2K 1/4WV Rd
R25	RC0266	47K 1/4WV Rd
R26	RC0266	47K 1/4WV Rd
R29	RD0132	680 1/2WV Rd
R30	RC0270	6.8K 1/4WV Rd
R31	RC0270	6.8K 1/4WV Rd
R32	RC0270	6.8K 1/4WV Rd
R33	RC0270	6.8K 1/4WV Rd
R34	RD01518	2.2 1/2WV Rd
R35	RD0040	1.8K 1/4WV Rd
R36	RD0305	2.4K 1/4WV Rd

Remarks; Capacitor: El Electrolytic, Ce Cermaic, My Mylar Ta Tantalum.
Resistor Rd Carbon, Ro Oxid Metal

SPECIFICATIONS

(Phono Motor Section)

Drive System	: Belt Drive System
Motor	: Brushless & Slotless DC Servo Motor
Turn Table Platter	: 30 cm (12") Aluminum-Cast 3.5 kgs (7.7 lbs)
Inertia Moment	: 500 kg cm
Rotation	: 33-1/3 rpm, 45 rpm
Adjusting Range of rotation	: ± 3% (33-1/3, 45 rpm Independent)
Wow & Flutter	: No more than 0.03% (W.R.M.S.)
Signal to Noise Ratio	: Better than 60 dB (I.E.C.B.)
Run-up Time	: Within 3 seconds

(Additional Features)

Vacuum Disc Stabilizer	: Manual Type
Stroboscope	: Illumination by built-in Quartz Oscillator
Acrylic Cover	: 4 mm-thick, Detachable, 1.8 kgs (4 lbs.)
Insulator	: Double Insulation System with Horizontal Balance Adjust Facility
Tonearm Base	: Detachable

(General)

Power Consumption	: 15 W
Dimensions	: 490(W) × 390(D) × 200(H) mm (19.6" × 15.6" × 8")
Weight	: Net 18 kgs (39.6 lbs.)

Specifications and appearance designn subject to change without notice.

SCHEMATIC DIAGRAM

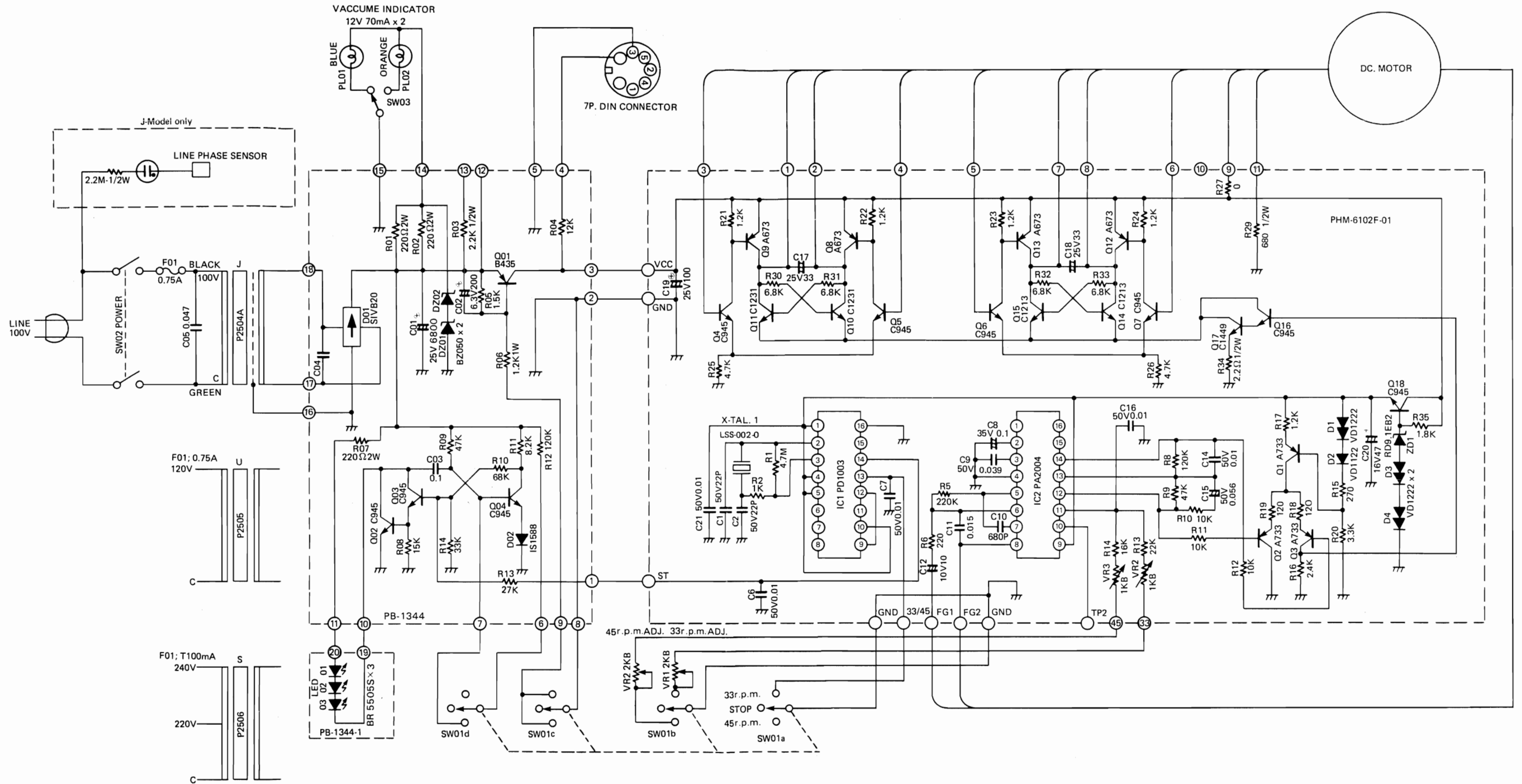

1. PB-1344 Unless otherwise specified, all resistors are in ohm 1/4W, all capacitors are in micro-farad.
PHM-6102F-01 Unless otherwise specified, all resistors are in ohm 1/8, all capacitors are in micro-farad.
2. Transistors and diodes may be replaced with any types having comparable ratings.
3. Due to continued improvement LUX reserve the right to alter the circuit or specification.

LUX CORPORATION, JAPAN

1-1, 1-CHOME, SHINSENRI-NISHIMACHI, TOYONAKA-SHI, OSAKA 565
PHONE: 06-834-0004 TELEX: 5287106 LUXELE J

Printed in Japan