

AM / FM STEREO RECEIVER —

R-1050

SERVICE MANUAL

R-1050

CIRCUIT DESCRIPTION

[POWER SUPPLY]

The AC line is connected to the primary side of power transformer via a two pole power switch (front panel) and a voltage selector. Four windings are provided for the secondary side i.e. (1) The 12V AC is utilized for 4 pilot lamps, and is at the same time half-wave rectified by D105 to realize DC 13V for the muting circuit and the blinker circuit. (2) 15V AC for tuner section: This 15V AC is half-wave rectified by D107 to obtain 18V unsmooth DC, which is further regulated by transistor Q113 and zener diode D108 to realize 13V regulated DC against $\pm 20\%$ AC line. (3) 35V AC for preamp (equalizer stage, intermediate stage and tone control): The 35V AC is half-wave rectified by D108 to obtain 44V unsmooth DC, which is turned into low noise 40V DC via ripple filter Q118. Actual supply voltage at each section is; equalizer stage 37V, tone control 27V, intermediate stage 24.5V, all of which are determined by the voltage-drop at the de-coupling circuit placed in each stage. (4) 36V x 2 AC for main amp.: The 36V x 2 AC are rectified by D001 - D004 and then led to large filtering capacitors C006 and C007 (10000uF x 2) to obtain dual supply +48V and -48V. (5) 21V x 2 AC for Peak Indicator, which are tapped out from the same winding of the above (4). The 21V x 2 AC are rectified by D603 - D606 to obtain dual supply +27V and -27V.

[PRE AMP SECTION]

The preamplifier consists of an equalizer, and intermediate amplifier, and a tone control. The equalizer adopts the Negative Feedback circuit using two silicon transistors, 2SA836 (Q101), 2SC1345 (Q102) per channel and is designed to provide proper equalization to the input signals. Input signals given through the AUX and TUNER section bypass the equalizer and are fed directly to the later stages of this amplifier.

Controls arranged after the equalizer stage are: REC. OUT connector, TPAE MONITOR SWITCH, DUBBING SWITCH, LOW-CUT FILTER, HIGH-CUT FILTER, MODE SELECTOR, VOLUME CONTROL, and LOUDNESS SWITCH. The intermediate amplifier consisting of Q301, Q302 is a flat amplifier adopting 2-stage Negative Feedback circuit which is designed to boost the equalizer, tuner or AUX. This covers sufficiently the insertion loss by the tone control in the next stage and leads low impedance output to the tone control for its smooth function. The tone control adopts the EB-NF circuit of Q201 and Q202. Any desired frequency response can be adjusted by the following controls: Variable resistor VR202 (Bass), and variable resistor VR201 (Treble). Major components of the preamplifier are arranged on the printed circuit boards PB1059-1061, 1064. (PB1064 for equalizer, PB1059 for Filters, Loudness and Mode, PB1060 for Flat Amp, PB1061 Tone Control)

[MAIN AMPLIFIER]

The main amplifier is of full stage direct coupling, two stage differential amplification, predriving and fully complementary circuits. The power transistors Q109 2SD388A (NPN) and Q110 2SB541A (PNP) (2-transistor per channel) are fitted over to the heat sink inside the chassis. All components are assembled to the printed circuit board PB1062. The differential amplifier is consisted of Q101 and Q102, the pre-driving stage of Q103, Q104, Q105 (Q103 & Q104 are for the differential amp, and Q105 is arranged for the active load of Q103), and the driver transistors, Q107 and Q108. Besides the above transistors, capacitors, resistors, and semi-fixed volume controls are integrated in the circuit.

[AM SECTION]

The RF signal received by the ferrite-rod antenna is converted into 455KHz IF frequency by Q113. The output of the local oscillation circuitry composed of Q113 and T105 is mixed in Q113 with the incoming radio signal to provide the 455kHz IF frequency, which is connected to the next stage.

[PEAK INDICATOR CIRCUIT] (PB-1063)

The output signal passed through the "Peak Indicator Sensitivity Selector Switch" SW505 meets the Peak Detection circuit composed of Q601, Q602 and C602, whose detected DC signal is then converted into low-impedance by current booster Q603 and Q604.

Of course different threshold level is arranged for each LED driver Q605 - Q610 to make them light up in accordance with the signal level.

[A.F.C.C. ----- Automatic Filter Control Circuit] (PB-1059)

At the time of AM reception, if the higher order harmonics caused by clipping of power amp are fed back to the AM antenna, the operation will be unstable. Therefore the harmonics passed through the high pass filter Q501 are detected by D501, which controls the electronic high frequency attenuator Q502 and C508 connected to the output of AM detector. Thus unstable factors such as oscillation are eliminated.

[MUTING & PROTECTION CIRCUIT] PB-1062

Charging of C114 is commenced through R130 and R132 by activating the Power Switch. Thus when base voltage of Q114 becomes 1.3V some 10 seconds later, the drivers of Ryl01, that is, Q114 and Q115 are turned on to connect the output of power amp to the speaker selector switch SW006.

When the power switch is released to off, C114 is discharged via D103 and R131, and promptly Ryl01 is turned to be 'break'.

In case such DC ingredient that exceeds $\pm 4V$ is at the output caused by abnormal operation of power amplifier, Q111 or Q112 is turned on, and C114 is discharged via D103 by Q113, thus Ryl01 is released.

[BLINKER CIRCUIT] (PB-1062)

During the breaking time of Ryl01, power is supplied to the vibrator to be oscillated, which turns LED101 on and off.

R-1050 ALIGNMENT PROCEDURE

The alignment procedure described in each chart may be performed independently, without affecting the others.

Warm up the signal generators for at least 15 minutes to make certain that they are stabilized at their operating temperature particularly generators containing vacuum tubes. Consult the instruction manual supplied with the particular test instrument for specific information concerning connection and operation.

The test equipment listed here is intended only as a guide, but alternate instruments should be of similar quality.

The following instruments are required for a complete alignment of the tuner.

1. Measurement instruments and Tools

- | | | | |
|----------------|--------------------------------|-------------------|---------------------------------------|
| Signal Source: | 1) FM signal generator (FMSG) | Output Indicator: | 7) Oscilloscope (CRO) |
| | 2) Sweep generator (SWG) | | 8) Distortion Meter (HDM) |
| | 3) AM signal generator (AMSG) | | 9) AC voltmeter (ACVTVM) |
| | 4) FM stereo modulator (MPXSG) | | 10) DC volt meter (DCVTVM) |
| | 5) Audio Oscillator (AFO) | Tools: | 11) Hex head alignment tool |
| | 6) AM standard loop antenna | | 12) Thin plastic shaft alignment tool |

2. General alignment conditions

- 1) The normal test voltage is within 10% of what is indicated on the receiver with less than 2% harmonic distortion.
- 2) Unless otherwise specified, the normal ambient temperature is 15°C - 25°C and humidity 55 - 75%. But if this is not possible, 5 - 35°C, 45 - 85% will provide acceptable results.
- 3) FM dummy antenna shall be as follows if not otherwise specified. The output voltage of the signal generator is 1/4 of the unloaded terminal voltage.

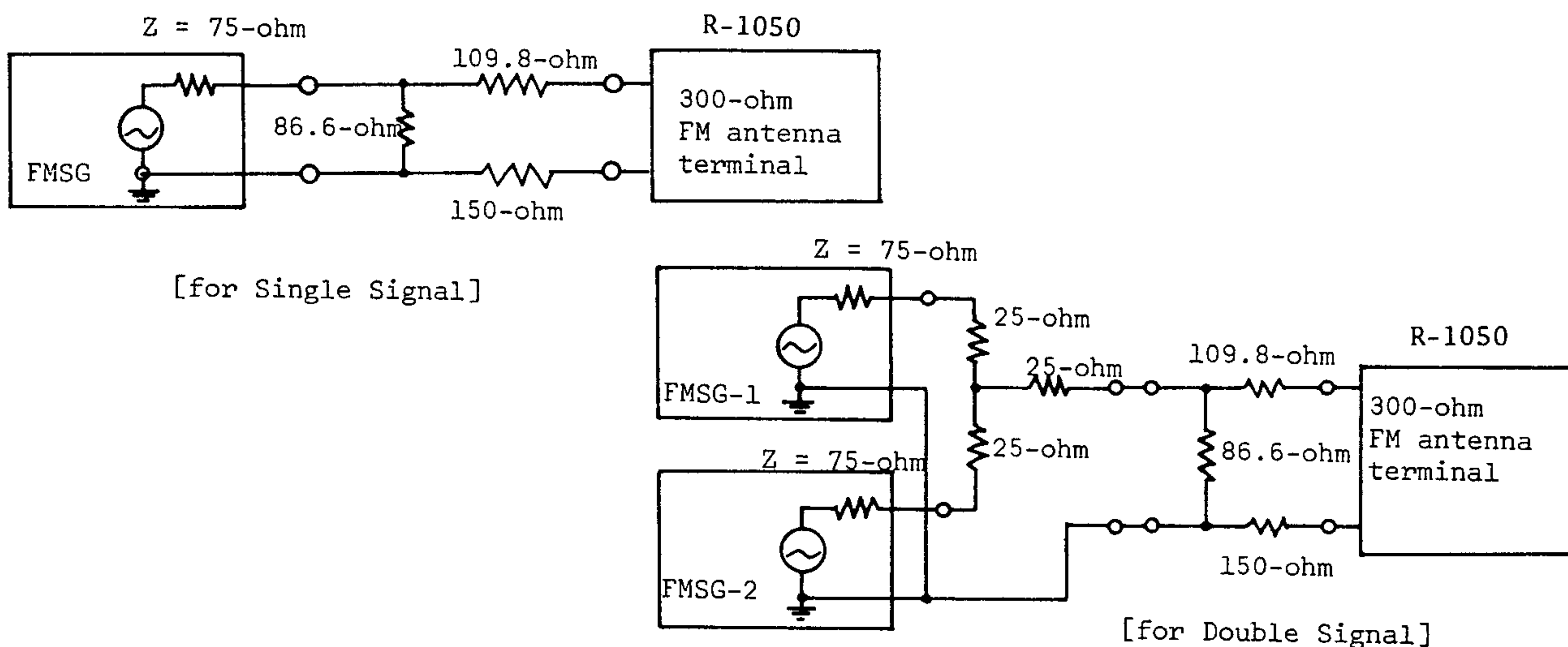

- 4) Connect the low side of signal source and the output indicator to the chassis ground as close as possible to the high side connection unless otherwise specified.
- 5) The 10.7 MHz marker used in each section of the alignment should be the same.
- 6) Marker insertion and amplitude should not distort the oscilloscope trace.
- 7) The AM standard loop antenna should be set above the ferrite loopstick antenna.
- 8) The output level of the sweep generator is measured by the output attenuator regardless of its terminated impedance.
- 9) FM modulation is 100% with $\pm 75\text{KHz}$.
- 10) All tuner audio output measurement are at TAPE OUT 1.

TUNER SECTION ALIGNMENT PROCEDURE

[CAUTION]

1. FM alignment must be done after 5 minutes of the power switch "ON".
2. Low distortion SG or stereo signal generator is indispensable for the FM-mono, stereo alignment procedure.

Preliminary Check	1.	Voltage selector must be at the appointed voltage.
	2.	Fuses on PB-1054 must be the appointed one.
	3.	Set the Input Selector Switch at the "AM" position.
	4.	Set the Dial Pointer at the maximum-right position.
	5.	Set all semi-fixed pots (6 pcs) at their centre position.
	6.	Select the De-emphasis Switch to the appointed time-constant.
AM Section Alignment	7.	Push the Power Switch to "ON", and confirm if there is no trouble.
	8.	Measure the voltage at the (+) side of power rectifying diode D107, which must be $8V \pm 1V$.
	9.	Voltage at Pin No.41 or No. 42 must be $18V \pm 1V$.
	10.	Set the output of 455KHz Sweep Generator for AM at 40dB, and connect it to Pin No.35. At the same time connect the line input of the SG to the TP-2.
	11.	Adjust the Ceramic Filter T105 and T106, and the Detector IFT T107 to have symmetrical response.
	12.	Set the loop antenna connected to AM-SG at the measuring position.
	13.	Connect oscilloscope and milivoltmeter to the REC. OUT terminal.
	14.	Obtain 400Hz 30% modulation on AM SG, and set the output attenuator at 80dB.
	15.	Set both SG and the dial pointer at 600KHz.
	16.	Adjust T104, Ferrite-core antenna and RF coil T103 to obtain maximum response on the signal meter or 400Hz sine-wave.
	17.	Set SG and the Dial Pointer at 1400KHz.
	18.	Adjust 3 trimmers on top of the variable capacitor (viewing from front, the right side is for OSC.) to obtain maximum response on the Signal Meter or 400Hz sine-wave. Repeat steps 15-18 for 2 or 3 times to obtain maximum sensitivity.
	19.	Set SG and the Dial Pointer at 1000KHz, and at maximum output level (126dB), adjust VR106 to have 4.5 reading on the Signal Meter calibration.
	20.	Check that all the specification items, sensitivity, output level, etc., are fulfilled.

Note the following adjustment must be done at least 5 minutes after the power "ON".

FM Frontend & IF Section Alignment	21.	Set the Input Selector Switch at the "FM" position.
	22.	Connect milivoltmeter, distortion meter and synchroscope to the REC. OUT terminal.
	23.	Connect FM SG of 400Hz 100% modulated to the 300-ohm ANT. terminal through balun. In this case the attenuator of the SG must be minimum, and set VR101 at the extreme counter-clockwise direction.
	24.	Set SG and the Dial Pointer at 98MHz. Short-circuit Pin No.19 and 21 on PB-1054.
	25.	Adjust the detection transformer T101 to obtain center indication of the center meter.
	26.	Set the SG output at 1mV, and adjust VR102 to have 1.0V output level at REC.OUT. Adjust detection trans T102 (both L & R ch) to realize minimum distortion (no more than 0.1%).
	27.	Set SG output at minimum, and turn the tuning knob to let the center meter stay at the center. Then set SG output at 1mV, and adjust detection trans T101 and T102 for 2 or 3 times to realize minimum distortion of the detection output.
	28.	Set SG and dial pointer at 108MHz, then obtain 1.5 - 1.8uV of SG output.
	29.	Adjust the trimmer on top of the Frontend (RF, ANT side) to obtain maximum indication of milivoltmeter.
	30.	Set SG and dial pointer at 98MHz, then obtain 1.5 - 1.8uV SG output.
	31.	Adjust IF core on the Frontend to obtain maximum indication of milivoltmeter.
	32.	Set SG output at 1.9uV.
	33.	Set the muting switch at "ON", and adjust VR101 to set muting point. In this case set it so that 400Hz detection output waveform can be stable against the level fluctuation and that stable output is feasible. After adjustment set the switch to "OFF".
	34.	Repeat step 27 and check distortion. Center; 0.1%, Limit; 0.2%
	35.	Set SG output at 1mV, then adjust VR105 to have 4.5 reading on the signal meter calibration.
	36.	Check that all the specification items such as sensitivity, output level, etc., are fulfilled.
	37.	Set FM SG 100% modulated, and connect both equipments to the 300-ohm ANT. terminal through 300-ohm balun.
	38.	Connect distortion meter, milivoltmeter, oscilloscope or synchroscope to the REC. OUT terminal. Remove short circuit made between 19 and 21.
	39.	Set SG and the dial pointer at 98MHz, and fix the SG output at 1mV.

	40.	Connect Frequency Counter to TP-1, and adjust VR104 to obtain 19KHz +0, -10KHz. Only this case, the pilot signal of the SG should be "OFF".
	41.	Modulate the L-ch of the stereo signal generator, and make note of the output by the milivoltmeter.
	42.	Adjust VR103 to obtain minimum movement of the L-ch milivoltmeter.
	43.	Measure the distortion and separation on both channels, which must fulfill the specification. Note that only in the case the distortion is critical against the spec., adjust the IF core in the Frontend within 1/3 turn.
	44.	Switch on and off the pilot signal, and confirm if the stereo indicator LED's light up in accordance with the signal.
	45.	Confirm all specification items such as S/N ratio etc. are fulfilled. And make note of them.
FM Dolby Section Alignment	46.	Set the input selector switch at the "FM" position, and the FM Dolby switch at the "DOLBY" position. At this time confirm if the Dolby indicator LED's light up.
	47.	Set SG and the dial pointer at 98MHz, and fix the SG output at 1mV.
	48.	Adjust VR801 on the Dolby printed circuit board PB-1055 to obtain 580mV output level at the L-ch REC. OUT terminal. At this step, stereo signal generator must be---modulation L+R 50% and pilot signal 10%.
	49.	Same as the above. Adjust VR802 on PB-1055 to have 580mV output level at the REC. OUT terminal.
	50.	Set stereo signal generator at 100% modulation at 1KHz. Confirm the output level of L-ch and R-ch at REC. OUT terminal is 1.1V.

IDLE ADJUST

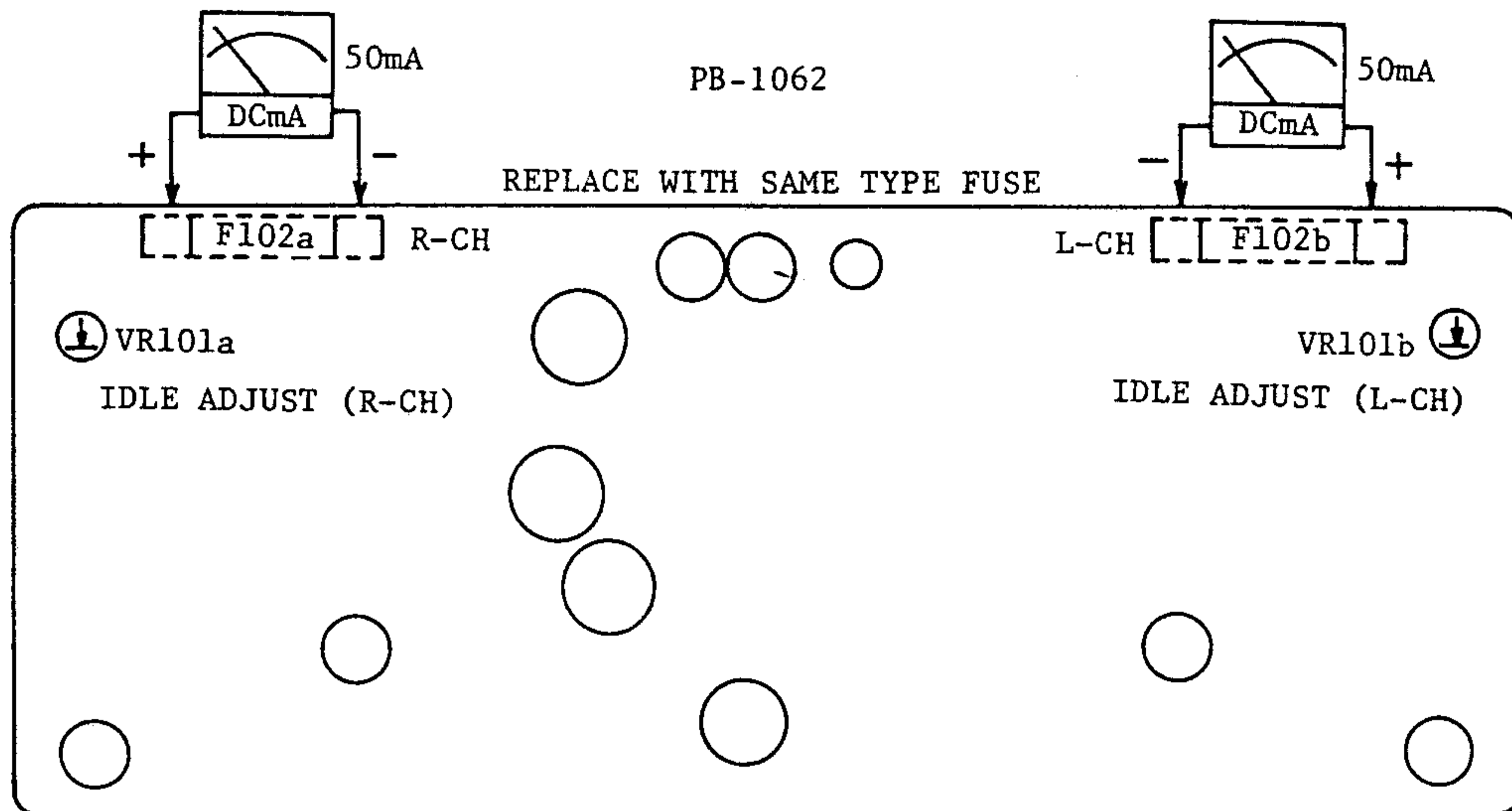

Idle Adjust

VR101a (R-ch) and VR101b (L-ch) on PB1062 are semifixed potentiometer for quiescent current adjustment of the power transistors.

First, remove both fuses of F102a (R-ch) and F102b (L-ch), and then insert a DC ammeter between the fuse grips. (+ for the edge-side grip).

After one minute of POWER-ON, adjust VR101a and VR101b respectively to have 50mA reading on the meter.

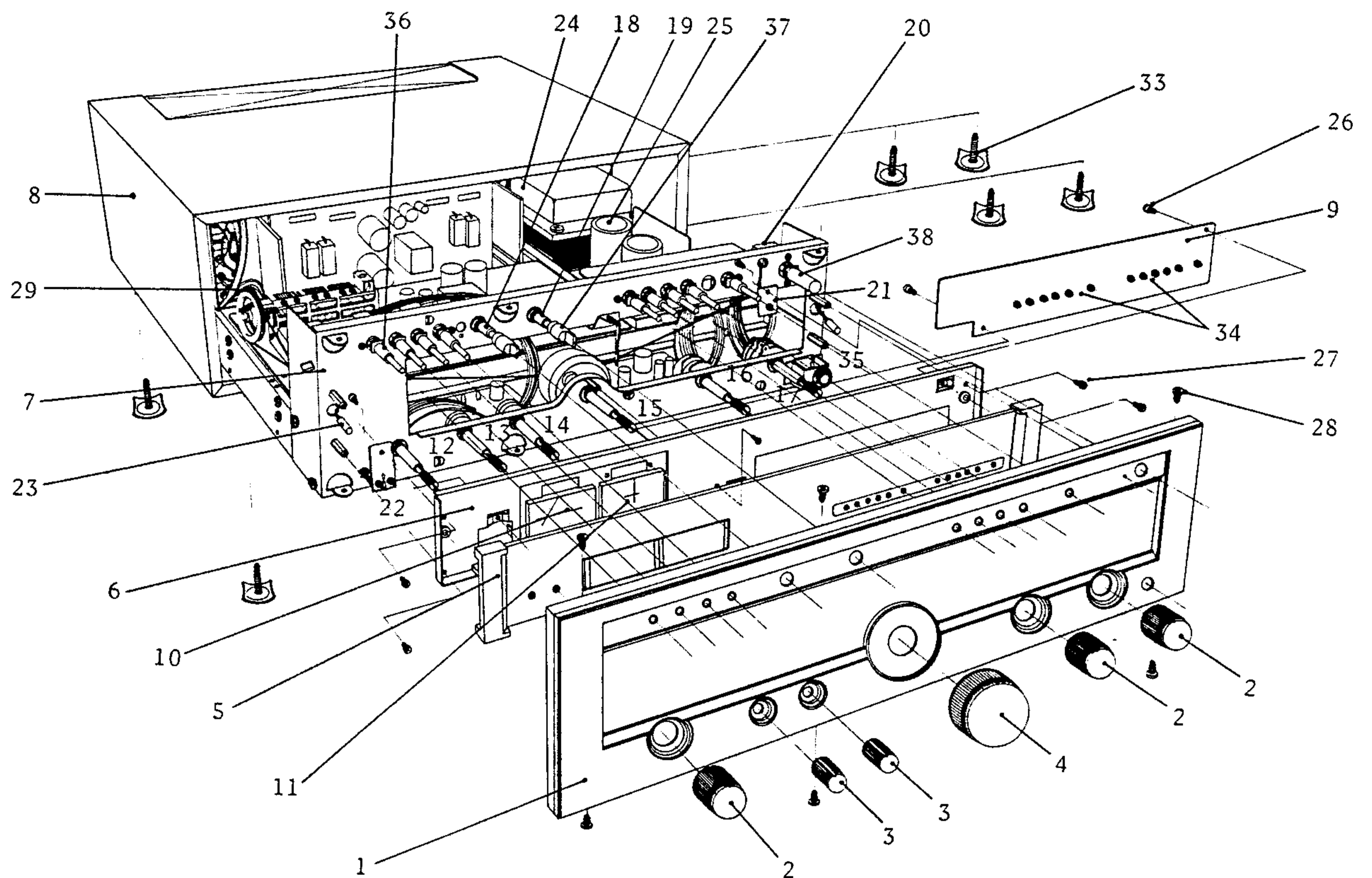

1. Front Panel (WA1068)
2. Knob (WJ1033, function etc.)
3. Knob (WJ1034, tone cont.)
4. Knob (WJ1035, tuning)
5. Dial Scale Ass'y (WM1024)
6. Holder
7. Sub Panel (UB1024)
8. Wooden Case (WB1043)
9. PB-1063
10. Signal Strength Meter (AM0041)
11. FM Fine Tuning Meter (AM0042)
12. Rotary Sw. (SR0081, Input Select.)
13. VR. (100k x 2)
14. VR. (50k x 2)
15. Tuning Shaft & Flywheel (UB1003)
16. VR. (200k x 2)
17. Rotary Sw. (SR0083, speaker)
18. Rotary Sw. (SR0082, dubbing)
19. VR. (250kMN x 2, balance)
20. Power Sw. (SP0070)
21. L.E.D. (TD0088)
22. L.E.D. (TD0088)
23. Dial Lamp (AL0039)
24. Power Transformer (PT0119)
25. Electrolytic (CE1408, 10000uF 50V)
26. Screw 3mm x 6mm
27. Screw 3mm x 6mm
28. Screw 4mm x 10mm
29. Drum (BX0016)
30. Plastic Pulley (BX0022)
31. Tuning Pointer (UZ1090)
32. Dial Cord
33. Screw 4mm x 20mm
34. L.E.D. (TD0088)
35. Headphone Jack (AJ0015)
36. Mould Knob (WJ1069)
37. Mould Knob (WJ1067)
38. Mould Knob (WJ1066)

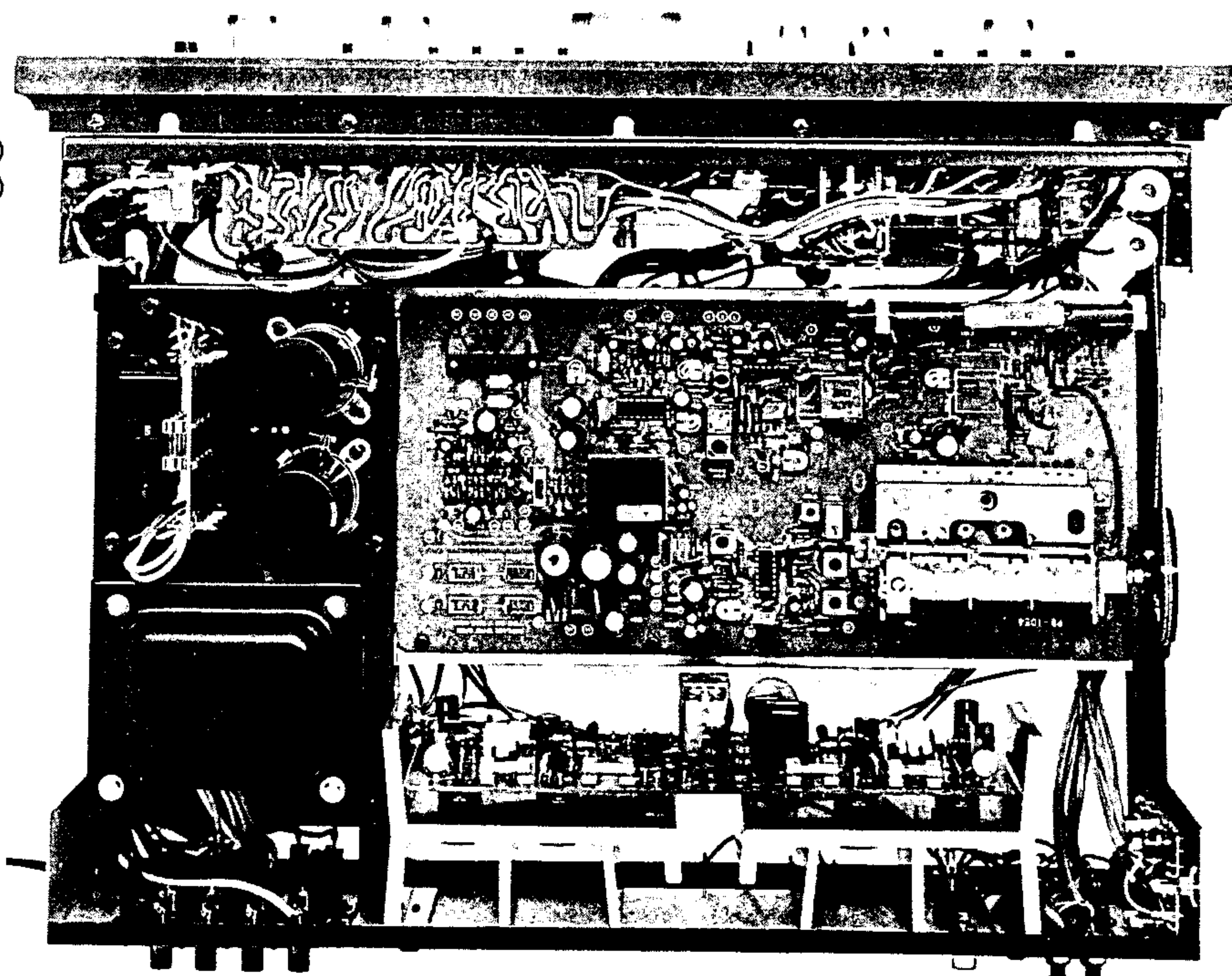
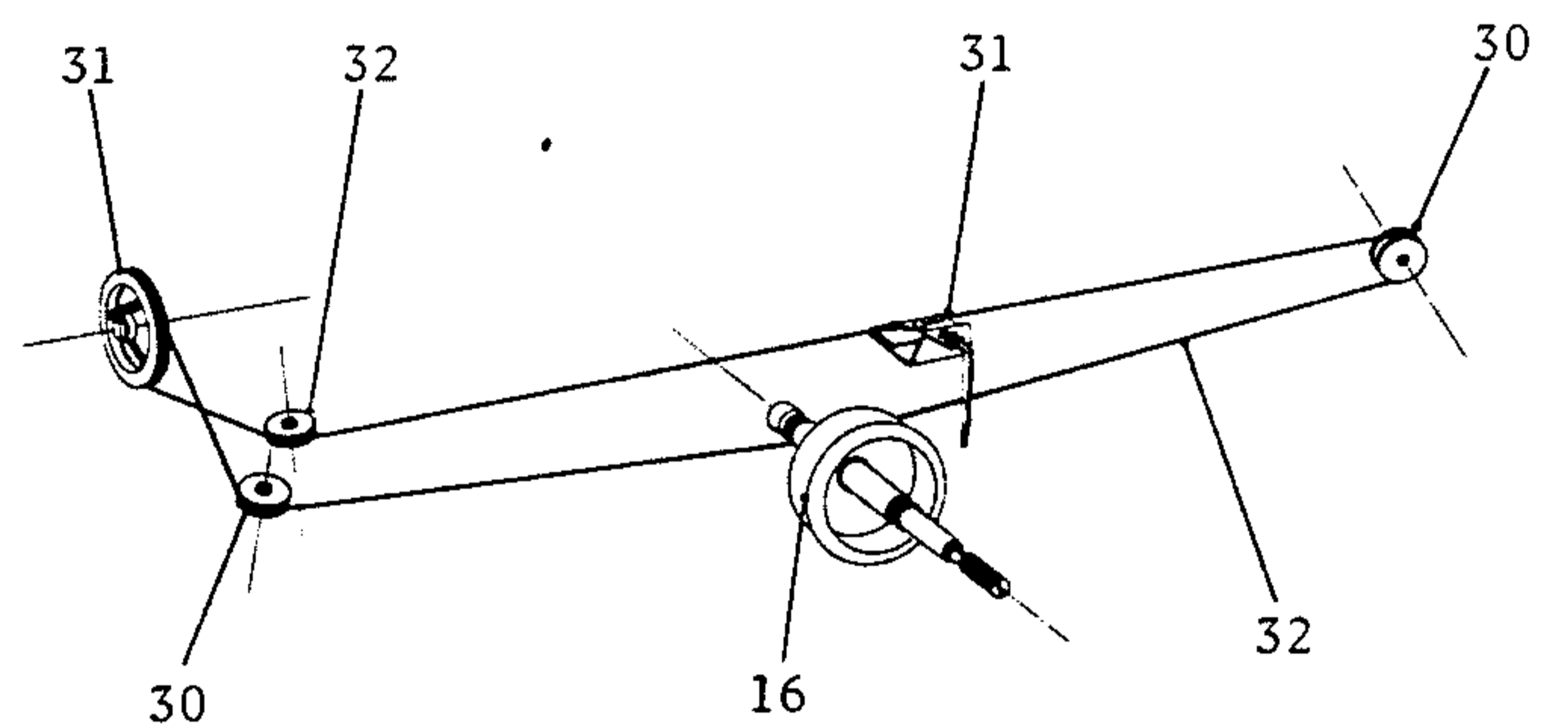

REPLACEMENT PARTS LIST

PB-1054

RESISTORS (+5%, 1/4W unless otherwise noted)

SYMBOL NO.	STOCK NO.	DESCRIPTION	SYMBOL NO.	STOCK NO.	DESCRIPTION
R101	RD0028	15k	R147	RD0008	560k
102	RD0025	27k	148	RD0046	680
103	RD0022	47k	149	RD0037	3.3k
104	RD0034	5.6k	150	RD0037	3.3k
105	RD0022	47k	151	RD0009	470k
106	RD0043	1k	152	RD0009	470k
107	RD0020	68k	153	RD0026	22k
108	RD0029	12k	154	RD0026	22k
109	RD0022	47k	155	RD0022	47k
110	RD0050	330	156	RD0034	5.6k
111	RD0050	330	157	RD0009	470k
112	RD0056	100	158	RD0050	330
113	RD0037	3.3k	159	RD0024	33k
114	RD0061	47	160	RD0013	220k
115	RD0056	100	161	RD0029	12k
116	RD0037	3.3k	162	RD0043	1k
117	RD0043	1k	163	RD0024	33k
118	RD0056	100	164	RD0013	220k
119	RD0056	100	165	RD0022	47k
120	RD0047	560	166	RD0052	220
121	RD0024	33k	167	RD0034	5.6k
122	RD0024	33k	168	RD0050	330
123	RD0030	10k	169	RD0009	470k
124	RD0065	22	170	RD0260	270 2W
125	RD0028	15k	171	RD0051	270
126	RD0030	10k	172	RD0017	100k
127	RD0043	1k	173	RD0053	180
128	RD0029	12k	174	RD0030	10k
129	RD0022	47k	175	RD0030	10k
130	RD0039	2.2k	176	RD0043	1k
131	RD0048	470	178	RD0034	5.6k
132	RD491	2k	179	RD0041	1.5k
133	RD0022	47k	180	RD0025	27k
134	RD0022	47k	181	RD0054	150
135	RD0034	5.6k	182	RD0054	150
136	RD0026	22k	183	RD0056	100
137	RD0020	68k	187	RD0052	220
138	RD0022	47k	191	RD0056	100
139	RD0043	1k			
140	RD0029	12k			
141	RD0028	15k			
142	RD0056	100			
143	RD0041	1.5k			
144	RD0037	3.3k			
145	RD0037	3.3k			
146	RD0048	470			

CAPACITORS(C...ceramic, E...electrolytic, S...styrol, T...tantalum, M...mylar)

SYMBOL NO.	STOCK NO.	DESCRIPTION
C101	CK0011	0.01uF 25V C +80%-20%
102	CK0011	0.01uF 25V C "
103	CK0011	0.01uF 25V C "
104	CK0010	0.04uF 25V C "
105	CK0010	0.04uF 25V C "
106	CE0213	0.47uF 50V E +75%-10%
107	CK0010	0.04uF 25V C "
108	CK0019	470pF 50V C +10%
109	CK0010	0.04uF C -10%
110	CK0011	0.01uF C

C111	CK0011	0.01uF		C	
112	CK0011	0.01uF		C	
113	CK0011	0.01uF		C	
114	CK0011	0.01uF		C	
115	CK0011	0.01uF		C	
116	CK0010	0.04uF		C	
117	CK0010	0.04uF		C	
118	CK0010	0.04uF		C	
119	CE0099	2.2uF	50V	E	
120	CK0011	0.01uF		E	
121	CK0010	0.04uF		E	
122	CK0010	0.04uF		E	
123	CK0010	0.04uF		E	
124	CE0099	2.2uF		E	
125	CC0007	100pF		C	
126	CE0213	0.47	50V	E	
127	CK0010	0.04		C	
128	CK0010	0.04		C	
129	CE0098	1uF	50V	E	+75%-10%
130	CE0074	10uF	16V	E	+50%-10%
131	CE0076	33uF	16V	E	"
132	CE0098	1uF	50V	E	+75%-10%
133	CQ0041	1000pF	50V	S	+5%-5%
134	CS0028	0.33uF	35V	T	+50%-20%
135	CE0213	0.47uF	50V	E	
136	CS0028	0.33	35V	T	
137	CE0099	2.2uF	50V	E	+75%-10%
138	CE0099	2.2uF	50V	E	"
139	CE0079	220uF	16V	E	+50%-10%
140	CQ0202	1600pF		S	
141	CQ202	1600pF		S	
142	CQ0100	820pF		S	
143	CQ0100	820pF		S	
144	CQ0043	1200pF		S	
145	CQ0043	1200pF		S	
146	CE0079	220uF	16V	E	+50%-10%
147	CE0084	4.7uF	25V	E	+75%-10%
148	CK0019	470pF	50V	C	+10%-10%
149	CQ0008	0.056uF		M	
150	CE0084	4.7uF	16V	E	
151	CK0019	470pF		C	
152	CQ0008	0.056uF		M	
153	CE0076	33uF	16V	E	+50%-10%
154	CE0090	1000uF	25V	E	"
155	CE0090	1000uF	25V	E	"
156	CE0079	220uF	16V	E	"
157	CE0079	220uF	16V	E	"
158	CE0079	220uF	16V	E	"
159	CK0010	0.04uF		C	
160	CK0011	0.01uF		C	
161	CK0010	0.04uF		C	
162	CK0010	0.04uF		C	
163	CE0079	220uF	16V	E	+50%-10%
164	CE0114	3.3uF	25V	E	+75%-10%
165	CE0084	4.7uF	25V	E	"
166	CK0011	0.01uF		C	
167	CK0010	0.04uF		C	
168	CK0064	0.001uF		C	+20%-20%
169	CK0024	0.002uF		C	"
170	CK0063	0.02uF		C	
171	CK0010	0.04uF		C	
172	CK0063	0.02uF		C	
173	CK0011	0.01uF		C	
174	CE0074	10uF	16V	E	+50%-10%
175	CK0010	0.04uF		C	
176	CK0063	0.02uF		C	
177	CQ0172	330pF	50V	S	+5%-5%
178	CC0004	22pF	50V	C	+10%-10%
179	CC0080	15pF	50V	C	+10%-10%
180	CC0033	10pF	50V	C	"
181	CK0010	0.04uF		C	

182	CK0010	0.04uF		C
183	CE0079	220uF	16V	E
184	CE0079	220uF	16V	E
185	CK0010	0.04uF		C
186	CK0010	0.04uF		C
197	CC0005	33pF	50V	C

SEMICONDUCTORS (PB-1054)

SYMBOL NO.	STOCK NO.	DESCRIPTION	SYMBOL NO.	STOCK NO.	DESCRIPTION
Q101	TR0014	2SC381 TR	Q113	TR0047	2SD235 TR
102	TC0011	BA401 IC	114	TC0021	HA1197 IC
103	TC0011	BA401 IC			
104	TC0020	LA1230 IC	D101	TD0018	1K188FM-1
105	TR0066	2SC1222 TR	102	TD0018	1K188FM-1
106	TC0012	LA3350SS IC	103	TD0053	1S2473
107	TF0001	2SK30A-0 FET	104	TD0053	1S2473
108	TR0146	2SC1740 TR	105	TD0053	1S2473
109	TR0066	2SC1222 TR	106	TD0053	1S2473
110	TR0068	2SA640 TR	107	TD0002	1N4002
111	TR0066	2SC1222 TR	108	TD0079	WZ140
112	TR0068	2SA640 TR	109	TD0018	1K188FM-1

FILTERS, COILS & TRANSFORMERS (PB-1054)

SYMBOL NO.	STOCK NO.	DESCRIPTION
F101	LA1106	CFSE-28AC-10 ceramic filter
102	LA1106	CFSE-28AC-10 ceramic filter
103	LA1107	BF-41 block filter
104	LA1103	FB-3204 low-pass filter
	LA1222	FB-722U12 front-end
T101	LA1092	LUX-1092 FM trans.
102	LA1093	LUX-1093 "
103	LA1097	LA1097 AM trans.
104	LA1073	LA1073 "
105	LA1098	FSN-1067 "
106	LA1099	NIT-7520 "
107	LA1100	LA1100 "
L101	LA1084	RC855-180K choke coil
102	LA1085	LUX-1085 "
103	LA1086	RC855-2R7M "
401		
Bn	LA1052	LUX-1052 balun

TRIMMER POTENTIOMETERS (PB-1054)

SYMBOL NO.	STOCK NO.	DESCRIPTION	SYMBOL NO.	STOCK NO.	DESCRIPTION
VR101	RT0054	KVSF8-7PNFB301	VR104	RT0051	KVSF8-7PNFB502
102	RT0051	" " 502	105	RT0052	" " 203
103	RT0050	" " 501	106	RT0055	" " 102

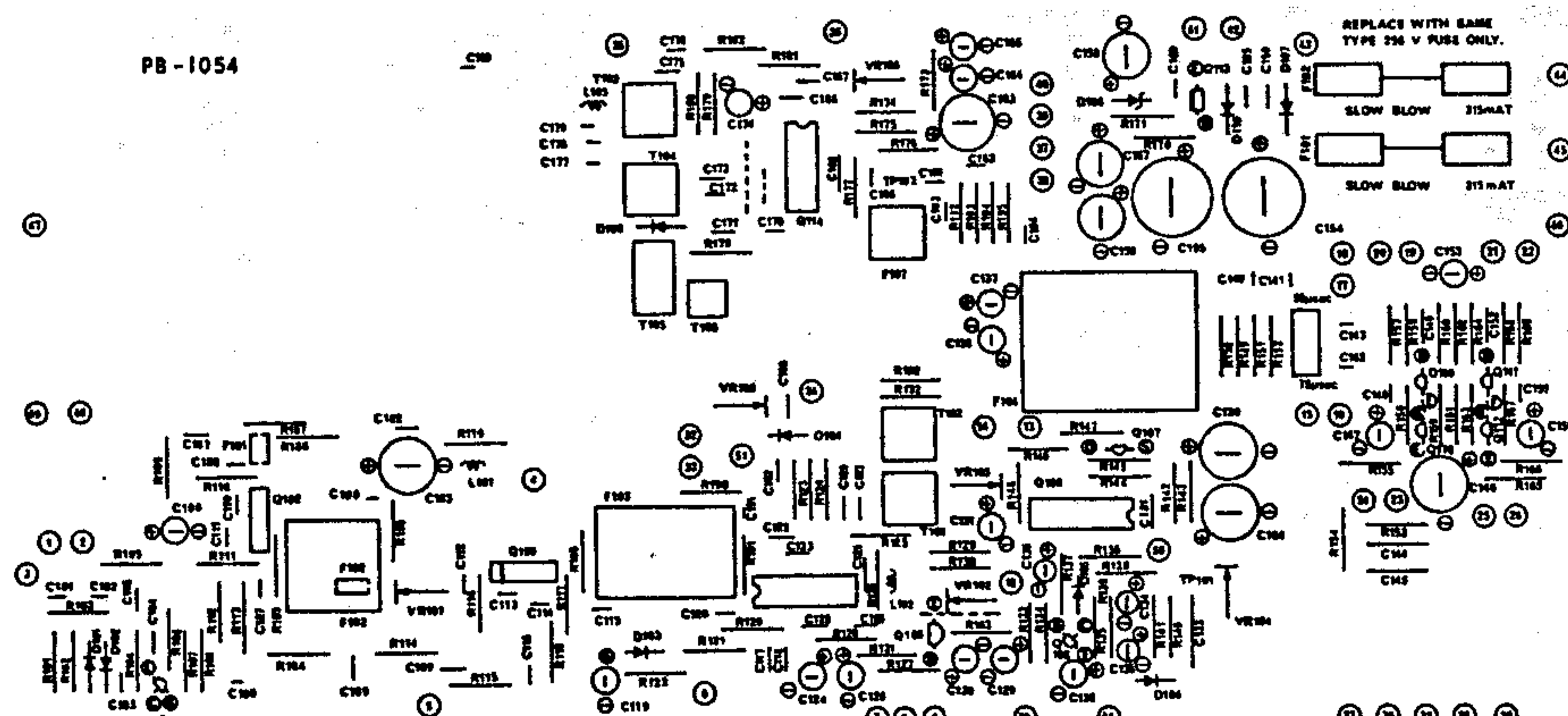

DOLBY UNIT (PB-1055)

SYMBOL NO.	STOCK NO.	DESCRIPTION	SYMBOL NO.	STOCK NO.	DESCRIPTION
R801	RD0043	1k	R815	RD0012	270k
802	RD0022	47k	816	RD0035	4.7k
803	RD0012	270k	817	RD0043	1k
804	RD0035	4.7k	818	RD0022	47k
805	RD0037	3.3k	819	RD0037	3.3k
806	RD0022	47k	820	RD0022	47k
807	RD0053	180	821	RD0053	180
808	RD0022	47k	822	RD0015	150k
809	RD0017	100k	823	RD0012	270k
810	RD0055	120	824	RD0007	680k
811	RD0007	680k	825	RD0055	120
812	RD0015	150k	826	RD0017	100k
813	RD0012	270k	827	RD0022	47k
814	RD0061	47			

CAPACITORS

SYMBOL NO.	STOCK NO.	DESCRIPTION
C801	CS0056	0.1uF 35V T +50%-20%
802	CE0213	0.47uF 50V E +75%-10%
803	CQ0121	0.12uF 50V M +10%-10%
804	CE0074	10uF 16V E +50%-10%
805	CE0074	10uF 16V E +50%-10%
806	CQ0012	0.027uF 50V M +10%-10%
807	CE0079	4700pF S +20%-20%
808	CE0074	220uF 16V E +50%-10%
809	CQ0009	10uF 16V E +50%-10%
810	CQ0029	0.047uF 50V M +10%-10%
811	CK0009	0.33uF 50V M +10%-10%
812	CE0074	0.1uF 25V C +80%-20%
813	CQ0069	10uF 16V E +50%-10%
814	CS0056	5600pF 50V S +5%-5%
815	CE0213	0.1uF 35V T
816	CQ0121	0.47uF 50V E
817	CE0074	0.12uF M
818	CE0074	10uF 16V E
819	CE0074	10uF 16V E
820	CE0079	220uF 16V E
821	CQ0050	4700pF S
822	CQ0069	5600pF S
823	CQ0012	0.027uF M
824	CE0074	10uF 16V E
825	CQ0009	0.047uF M
826	CQ0012	10uF 16V E
827	CE0074	0.1uF C
828	CQ0029	0.33uF M
829	CE0079	220uF 16V E
830	CE0077	47uF 16V E +75%-10%

SEMICONDUCTORS

SYMBOL NO.	STOCK NO.	DESCRIPTION	SYMBOL NO.	STOCK NO.	DESCRIPTION
Q801	TR0003	2SC1000 GR TR	D801	TD0018	1K188
802	TC0022	NE545B	802	TD0018	1K188
803	TR0003	2SC1000 GR TR			
804	TC0022	NE545B			

 PB-1059 (SWITCH BOARD)

RESISTORS

SYMBOL NO.	STOCK NO.	DESCRIPTION	SYMBOL NO.	STOCK NO.	DESCRIPTION
R501ab	RD0004	1M	R509	RD0030	10k
502ab	RD0033	6.8k	510	RD0022	47k
503ab	RD0004	1M	511	RD0024	33k
504ab	RD0025	27k	512	RD0043	1k
505ab	RD0029	12k	513	RD0035	4.7k
506ab	RD0013	220k	514	RD0017	100k
507ab	RD0021	56k	515	RD0030	10k
508ab	RD0025	27k	516	RD0009	470k

CAPACITORS

SYMBOL NO.	STOCK NO.	DESCRIPTION
C501ab	CQ0011	0.033uF 50V S
502ab	CQ0021	3300pF 50V S
503ab	CQ0011	0.033uF 50V S
504ab	CC0011	470pF 50V C
505	CK0064	1000pF 50V C
506	CK0064	1000pF 50V C
507	CE0074	10uF 16V E
508	CK0009	0.1uF 25V C
509	CE0099	2.2uF 50V E
007	CE0078	100uF 16V E

SEMICONDUCTORS (PB-1059 switch board)

SYMBOL NO.	STOCK NO.	DESCRIPTION	SYMBOL NO.	STOCK NO.	DESCRIPTION
Q501	TR0029	2SC945	D501	TD0016	1S1555
502	TR0029	2SC945			

SWITCHES

SYMBOL NO.	STOCK NO.	DESCRIPTION
SW501 - 505	SP0073	SUE53

 PB-1060 (FLAT AMP. BOARD)

RESISTORS

SYMBOL NO.	STOCK NO.	DESCRIPTION	SYMBOL NO.	STOCK NO.	DESCRIPTION
R301ab	RD0024	33k	R306ab	RD0027	18k
302ab	RD0022	47k	307ab	RD0043	1k
303ab	RD0004	1M	308ab	RD0034	5.6k
304ab	RD0009	470k	309	RD0037	3.3k
305ab	RD0038	2.7k			

CAPACITORS (PB-1060 FLAT AMP. BOARD)

SYMBOL NO.	STOCK NO.	DESCRIPTION
C301ab	CE0173	3.3uF 25V E LR
302ab	CE0078	100uF 16V E
303ab	CC0012	10pF 50V C
304ab	CE0173	3.3uF 25V E
305	CK0010	0.04uF 50V C
306	CE0103	100uF 50V E

SEMICONDUCTORS

SYMBOL NO.	STOCK NO.	DESCRIPTION	SYMBOL NO.	STOCK NO.	DESCRIPTION
Q301ab	TR0125	2SA836E	Q302ab	TR0025	2SC1345E

CAPACITORS (LL...low leakage type)

SYMBOL NO.	STOCK NO.	DESCRIPTION
C401ab	CS0008	2.2uF 25V T
402ab	CC0005	33pF 50V C
403ab	CE0078	100uF 16V E
404ab	CC0008	150pF 50V C
405ab	CQ0130	1000pF 50V S +5%-5%
406ab	CQ0130	1000pF 50V S +5%-5%
407ab	CQ0122	6800pF 50V S
408ab	CE2030	10uF 16V E LL
409ab	CC0037	5pF 50V C
410ab	CS0012	0.47uF 35V T
412	CE0068	47uF 10V E
413	CE0102	47uF 50V E

SEMICONDUCTORS

SYMBOL NO.	STOCK NO.	DESCRIPTION	SYMBOL NO.	STOCK NO.	DESCRIPTION
Q101ab	TR0125	2SA836E	Q102ab	TR0025	2SC1345E

PB-1062 POWER AMP BOARD

RESISTORS (FP...flame proof)

SYMBOL NO.	STOCK NO.	DESCRIPTION	SYMBOL NO.	STOCK NO.	DESCRIPTION
R101ab	RD0062	39k	R122ab	RS2696	4.7 1W
102ab	RD0037	3.3k	123ab	RS2708	15 1W
103ab	RD0029	12k	124ab	RD0032	8.2k
104ab	RD0048	470	125	RS2770	5.6k 1W
105ab	RD0032	8.2k	126	RS2770	5.6k 1W
106ab	RD0013	220k	127	RD0043	1k
107ab	RD0029	12k	128	RD0037	3.3k
108ab	RD0037	3.3k	129	RD0032	8.2k
109ab	RD0037	3.3k	130	RD0034	5.6k
110ab	RS0068	180 FP	131	RD0043	1k
111ab	RS0066	100 FP	132	RD0017	100k
112ab	RD0117	4.7k 1/2W	133	RD0039	2.2k
113ab	RD0022	47k	134	RD0020	68k
114ab	RD0054	150	135	RD0004	1M
115ab	RD0048	470	136	RD0023	39k
116ab	RD0040	1.8k	137	RD0004	1M
117ab	RD0047	560	138	RD0039	2.2K
118ab	RS0074	100 FP 1/2W	139	RS0074	100 FP 1/2W
119ab	RS0074	100 FP 1/2W	140	RD0030	10k
120ab	RG0060	0.33 +10% 5W	VR101ab	RT0013	330B
121ab	RG0060	0.33 +10% 5W			

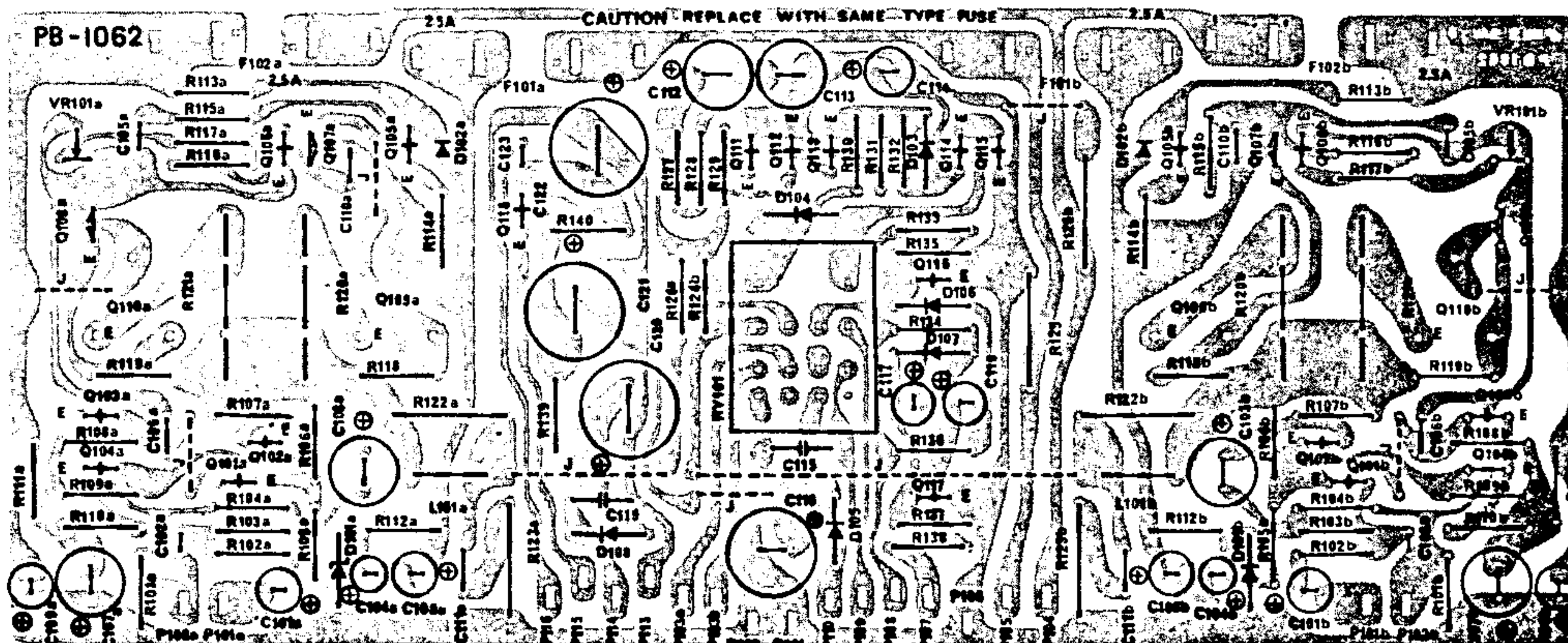

CAPACITORS (BP...bi-polar)

SYMBOL NO.	STOCK NO.	DESCRIPTION
C101ab	CE0173	3.3uF 25V E LR
102ab	CC0010	330pF 50V C
103ab	CE0070	220uF 10V E
104ab	CE0074	10uF 16V E
105ab	CK0010	0.04uF 25V C
106ab	CC0018	47pF 500V C
108ab	CE0219	2.2uF 100V E
109ab	CE0317	2.2uF 500V E
110ab	CC0036	100pF 500V C
111ab	CQ0005	0.1uF 50V S
112	CE0070	220uF 10V E
113	CE0070	220uF 10V E
114	CE0069	100uF 10V E
115	CU0012	0.01uF 1.5KV C
116	CE0087	220uF 25V E
117	CE0086	10uF 25V E
118	CE0086	10uF 25V E
119	CU0012	0.01uF 1.5KV C
120	CE0146	220uF 50V E
121	CE0146	220uF 50V E
122	CE0146	220uF 50V E
123	CC0007	100pF 50V C

SEMICONDUCTORS

SYMBOL NO.	STOCK NO.	DESCRIPTION	SYMBOL NO.	STOCK NO.	DESCRIPTION
Q101ab	TR0151	2SA750	Q110ab	TR0059	2SB541A power TR
102ab	TR0151	2SA750	111	TR0127	2SC733
103ab	TR0152	2SC1940	112	TR0127	2SC733
104ab	TR0152	2SC1940	114	TR0127	2SC733
105ab	TR0153	2SA915	116	TR0127	2SC733
106ab	TR0029	2SC945	117	TR0127	2SC733
107ab	TR0045	2SD381	113	TR0008	2SA562
108ab	TR0027	2SB536	115	TR0001	2SC734
109ab	TR0060	2SD388A power TR	118	TR0007	2SA561
D101ab	TD0027	WZ-120 zener	D105	TD0002	1N4002
102ab	TV0005	VD1221 varister	106	TD0016	1S1555
103	TD0018	1K188FM-1	107	TD0016	1S1555
104	TD0001	1N4001	108	TD0003	1N4003

OTHERS (PB-1062)

SYMBOL NO.	STOCK NO.	DESCRIPTION
Ry101	AY0028	MAT4B-BR12V relay
F101ab	BF0211	2.5A(T) or BF0300 fuse
F102ab	BF0211	2.5A(T) BF0300 fuse
L101ab	LA1004	2uH

PB-1056 (FUSE BOARD)

SYMBOL NO.	STOCK NO.	DESCRIPTION
C001-004	CU0004	0.01uF 250V P
D001-004	TD0120	1N5404
F001-004	BF0206	BF0308 0.5A

 PB-1063 (PEAK INDICATOR BOARD)

RESISTORS

SYMBOL NO.	STOCK NO.	DESCRIPTION	SYMBOL NO.	STOCK NO.	DESCRIPTION
R601ab	RD0026	22k	R613ab	RD0037	3.3k
602ab	RD0019	82k	614ab	RD0046	680
603ab	RD0030	10k	615ab	RD0035	4.7k
604ab	RD0032	8.2k	616ab	RD0046	680
605ab	RD0027	18k	617ab	RD0030	10k
606ab	RD0045	820	618ab	RD0040	1.8k
607ab	RD0041	1.5k	619ab	RD0040	1.8k
608ab	RD0046	680	620ab	RD0040	1.8k
609ab	RD0040	1.8k	621ab	RD0040	1.8k
610ab	RD0046	680	622ab	RD0033	6.8k
611ab	RD0039	2.2k	623ab	RD0033	6.8k
612ab	RD0046	680			

CAPACITORS

SYMBOL NO.	STOCK NO.	DESCRIPTION
C601ab	CE0171	4.7uF 16V E
602ab	CE0098	1uF 50V E
603	CE0250	100uF 35V E
604	CK0008	0.04uF 50V C
605	CK0008	0.04uF 50V C
606	CK0008	0.04uF 50V C
607	CK0008	0.04uF 50V C
608	CE0250	100uF 35V E

SEMICONDUCTORS

SYMBOL NO.	STOCK NO.	DESCRIPTION	SYMBOL NO.	STOCK NO.	DESCRIPTION
Q601ab-603ab	TR0127	2SC733	D601ab	TD0016	1S1555
604ab	TR0128	2SA495	602ab	TD0016	1S1555
605ab-610ab	TR0127	2SC733	603-606	TD0002	1N4002
			LED601ab - 606ab	TD0088	SLP-119B

 PB-1068

SYMBOL NO.	STOCK NO.	DESCRIPTION
	RD0043	1k resistor
	TD0088	SLP-119B LED

 PB-1069

SYMBOL NO.	STOCK NO.	DESCRIPTION
	TD0088	SLP-119B LED

BACK PANEL

STOCK NO.	DESCRIPTION
AC0010	AC Socket
AG0063	Earth Terminal
AS0002	DIN Connector
AT0006	8-pin Jack
AT0007	6-pin Jack
AT0051	SP Terminal
AT0053	Antenna Terminal
BE1031	Heat Sink
BU0045	PCB holder
CK0009	0.1uF ceramic
RD0004	1M-ohm, 1/4W
RD0015	150k-ohm, 1/4W
UC1044	Back Panel

SUB-PANEL

STOCK NO.	DESCRIPTION
AJ0015	Headphone Jack
AL0039	Lamp 12V 100mA
AM0041	Signal Meter
AM0042	Tuning Meter
BX0017	Pulley-shaft
BX0022	Pulley
CE0069	100uF 10V electrolytic
CE0077	47uF 16V "
RS2746	560-ohm 1W
RV0129	250k-MN
SP0070	Push SW (SDG5P502 4A)
SP0072	Push SW (SUE43A09B)
SR0081	Rotary SW (SRY5105105)
SR0082	Rotary SW (SRF2043113)
SR0083	Rotary SW (SRY2044132)
UB1003	Fly-wheel
UB1024	Sub Panel
UZ1090	Dial Pointer
WM1024	Dial Scale Plate

CHASSIS

STOCK NO.	DESCRIPTION
AC0013	voltage Selector Socket
AC0014	voltage Selector Plug
AH0016	1-P Fuse Holder X-N1157
AH0019	Fuse Holder X-N1153
BF0049	Fuse 2.5A(T)
BF0119	Fuse MF60NR-5A
BX0004	Bar Antenna Holder
BX0016	Dial Drum
CE0078	100uF 16V electrolytic
CE1408	10000uF 50V electrolytic
CU0031	AC capacitor 0.0022uF
CU0051	AC capacitor 0.0022uF
LA1057	Bar Antenna LUX-1057
PT0119	Power Transformer
RD0100	2.2M-ohm
BK0018	UL-AC cord
BK0020	AC cord
BK0022	AC cord
BK0023	AC cord SAA miniature

EXTERIOR

STOCK NO.	DESCRIPTION
BU0069	Leg
WA1068	Front Panel
WB1043	Wooden Case
WH1033	Knob Set (volume, input,
WH1034	Knob Set (tone cont.) speakers)
WH1035	Knob Set (tuning)
WJ1066	Mould Knob (power sw.)
WJ1067	Mould Knob (mode, balance)
WJ1069	Mould Knob (dolby FM, muting
WT1009	Ventilation etc.)
WT1020	Ventilation
XA1098	Packing Case

[AUDIO SECTION]		Distortion at 65dBf:		100Hz	0.1%	0.2%
Power Output:	55 watts minimum continuous per channel, both channels driven into 8-ohm loads, from 20Hz to 20,000Hz with no more than 0.05% total harmonic distortion.	1KHz	0.1%	0.2%		
Rated I.M.:	no more than 0.05% (8-ohm, both ch driven, 60Hz : 7KHz = 4 : 1)	6KHz	0.3%	0.4%		
Frequency Response:	10Hz - 50KHz (-1dB)	Intermodulation Distortion:	0.1%	0.2%		
Input Sensitivity:	2.5mV (phono), 150mV (aux., monitor)	Capture Ratio at 65dBf:	1.3dB	-		
Phono Overload Voltage:	150mV (1KHz)	Alternate Channel Selectivity:	70dB	-		
S/N Ratio:	66dB (phono), 86dB (aux., monitor)	Spurious Response Ratio:	90dB	-		
Residual Noise:	no more than 0.7mV	Image Response Ratio:	80dB	-		
Damping Factor:	no less than 60 (8-ohm)	IF Response Ratio:	85dB	-		
Tone Control:	Bass ±10dB at 100Hz Treble ±10dB at 10KHz	AM Suppression Ratio:	52dB	-		
Filters:	High Cut 7KHz (6dB/oct.) Low Cut..... 70Hz (6dB/oct.)	Stereo Separation:	100Hz	-	45dB	
Crosstalk at 1KHz:	-65dB (aux., monitor)	1KHz	-	-	45dB	
Peak Indicators:	0, -6, -9, -12, -15, -18dB	10KHz	-	-	40dB	
[FM SECTION] (IEEE/IHF Standard)		Subcarrier Product Ratio:	-	-	60dB	
Usable Sensitivity:	[mono] 10.3dBf (1.8µV) [stereo] 18.2dBf (4.6µV)	SCA Rejection Ratio:	-	-	60dB	
46dB Quieting Sensitivity: 50µS	14.1dBf (2.8µV) 37.4dBf (40µV)	[AM SECTION]				
50dB Quieting Sensitivity: 50µS	14.1dBf (2.8µV) 36.8dBf (38µV)	Usable Sensitivity at 1MHz, 400Hz, 30% mod.:				
Signal-to-noise Ratio at 65dBf:	74dB 70dB	EXT. ANT. 15µV				
Muting Threshold:	8.8dBf (1.5µV) 8.8dBf (1.5µV)	Signal-to-noise Ratio at 1MHz, 10mV, 400Hz, 30% mod.:				52dB
Frequency Response 30Hz to 15KHz:	+0.5, -1.5dB +0.5, -1.5dB	Distortion at 1MHz 10mV, 400Hz, 30% mod.:				0.5%
		Image Response ratio at 1MHz:				75dB
		IF Response Ratio at 1MHz:				80dB
		[GENERAL]				
		Power Consumption:	270W (at full power, 8-ohm)			
		Dimensions:	120V 2.5A (CSA rated)			
		Weight:	490 (W) x 355 (D) x 180 (H) mm			
			(19-5/16" x 14" x 7-3/32")			
			Net 13.5Kgs (29.7 lbs.)			
			Gross 15.5Kgs (34 lbs.)			

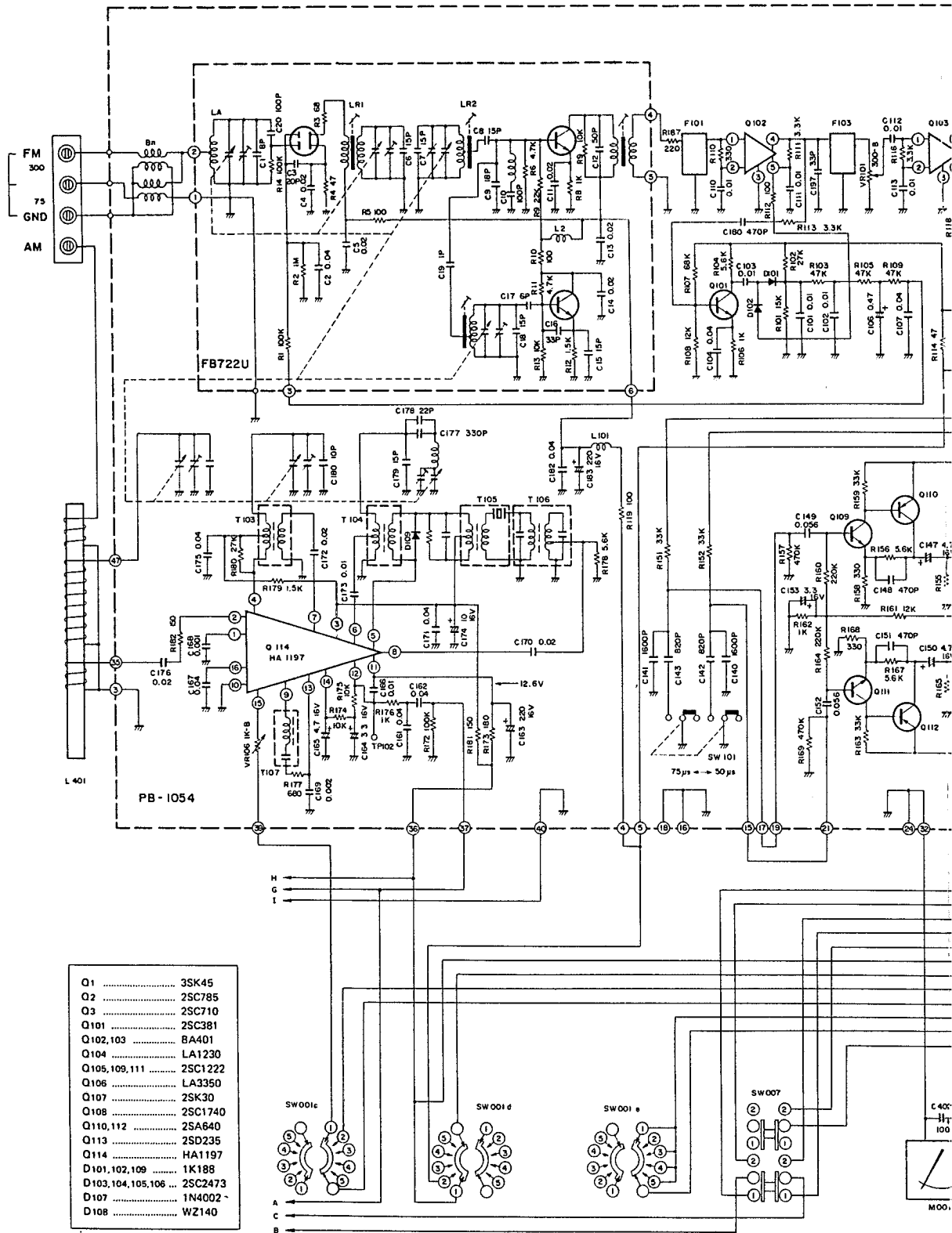

FM - DOLBY SWITCH
SIGN STRENGTH

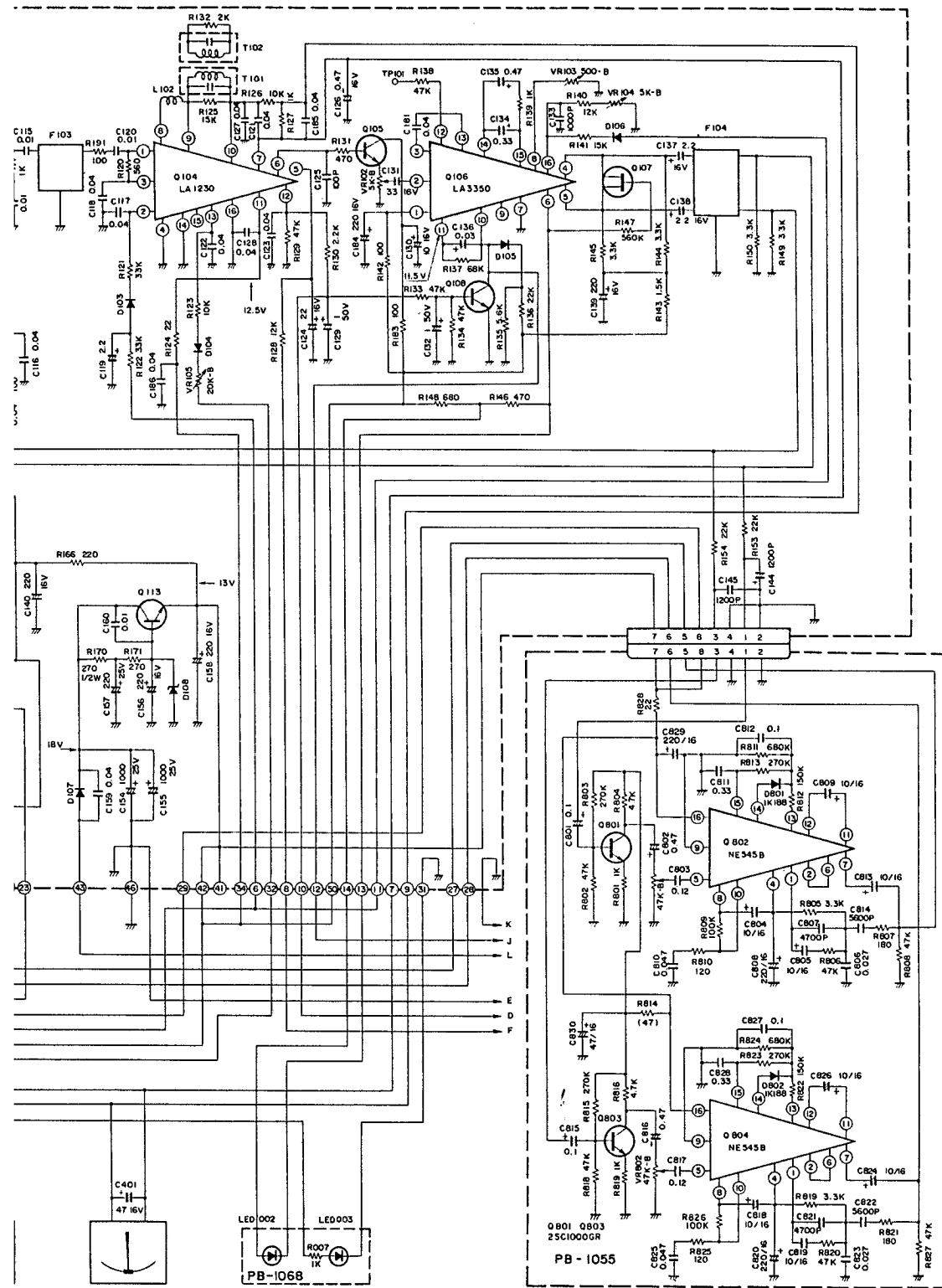

FM TUNING

STEREO IND
DOLBY IND

R-1050 RF SECTION

LUX CORPORATION, JAPAN

1-1, 1-CHÔME, SHINSENRI-NISHIMACHI, TOYONAKASHI, OSAKA
PHONES:06-834-2222 CABLE:LUXELECT OSAKA TELEX:J63694

LUX AUDIO OF AMERICA, LTD.

200 AERIAL WAY, SYOSSET, NEW YORK 11791, U.S.A.
PHONE: (516)822-7070

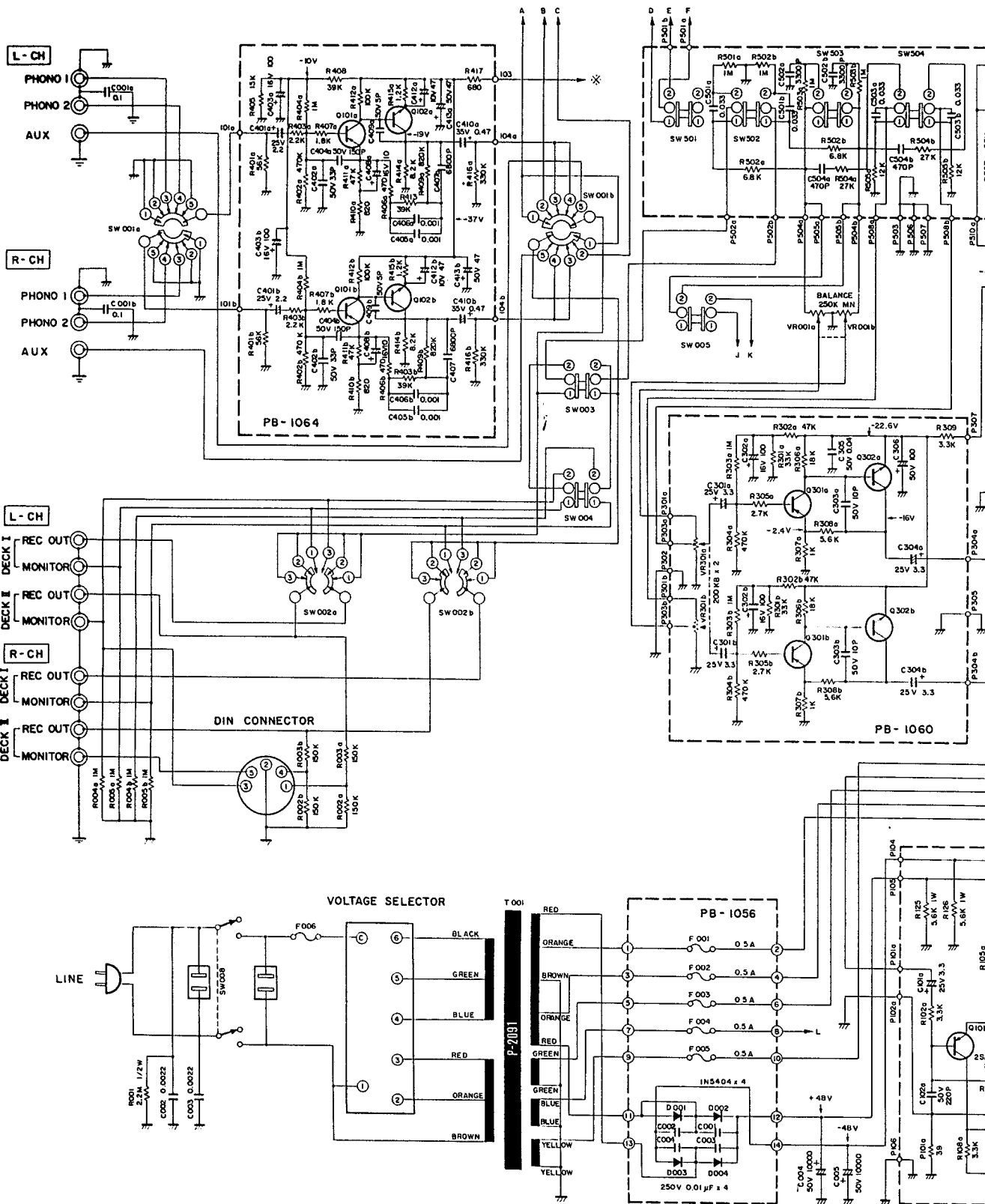

For north European countries, the AC outlet has been removed.

▲ R001 : only for Canada.
 F006 : 2.5A (220V north European countries)
 2.5A (220V, 240V)
 5A (100V, 120V)

Q 101a, 101b, 201a, 201b, 202a, 202b, 301a, 301b	25A836
Q 102a, 102b, 302a, 302b	25C1345
Q 601a, 601b, 602a, 602b, 603a, 603b, 605a, 605b, 606a	25C733
Q 606b, 607a, 607b, 608a, 608b, 609a, 609b, 610a, 610b	25C733
Q 111, 112, 114, 117	25C733
Q 103a, 103b, 104a, 104b	25C1940

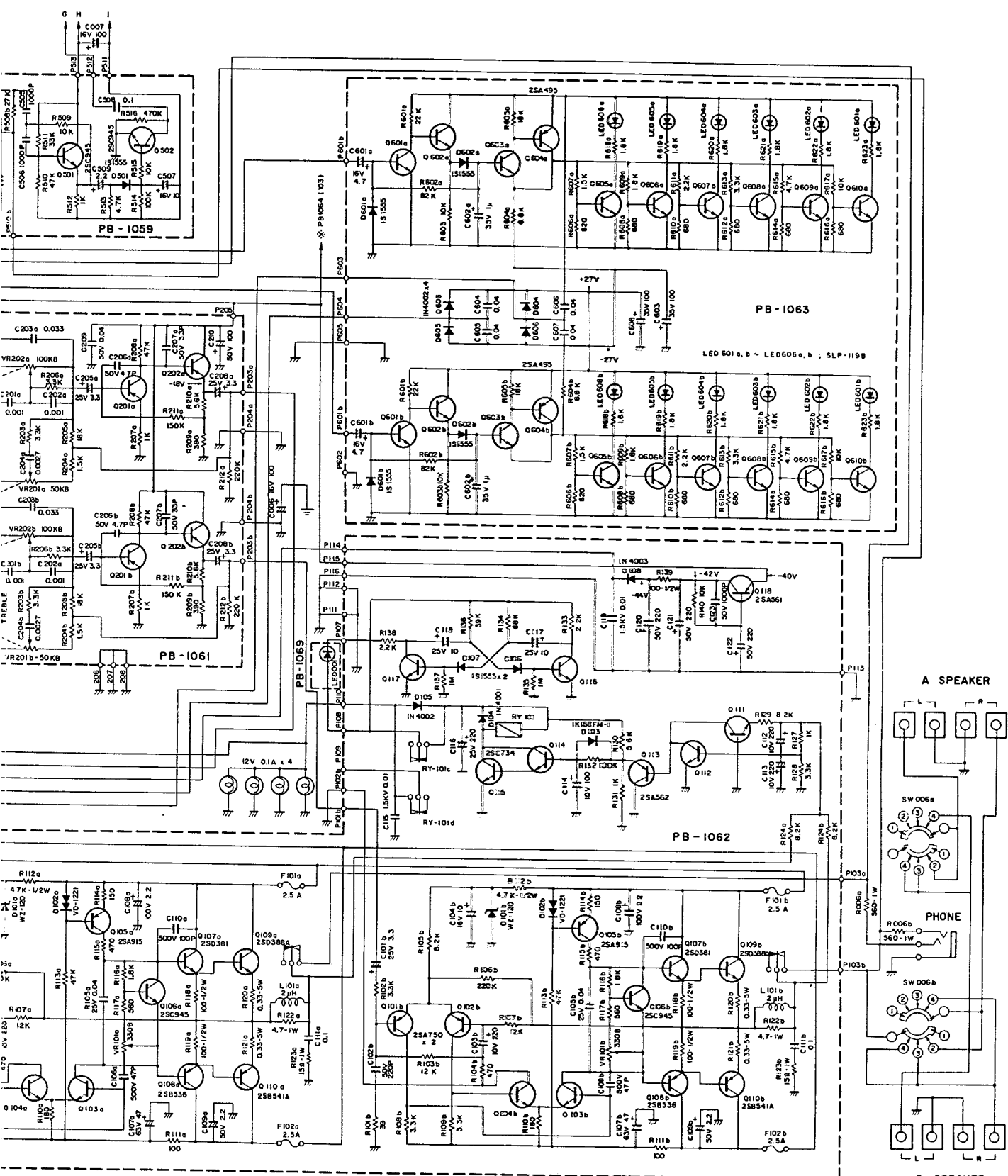

FUNCTION	① FM ② AM ③ PHONO 1 ④ PHONO 2 ⑤ AUX
DUBBING	① 1 TO 2 ② SOURCE ③ 2 TO 1
MONITOR	① OFF ② ON
MONITOR	① DECK I ② DECK II
MODE	① STEREO ② MONO
SPEAKER	① OFF ② A ③ B ④ A + B
DOLBY	① FM ② DOLBY
POWER	
FM MUTING	① OFF ② ON
LOW CUT	① OFF ② ON
HIGH CUT	① OFF ② ON
LOUDNESS	① OFF ② ON
PEAK IND	① 0dB ② -12dB

1. Unless otherwise specified, all resistors are in ohm $\frac{1}{2}$ watt, all capacitors are in micro-farad.
2. Transistors and diodes may be replaced with any types having comparable ratings.
3. Due to continued improvements LUX reserve the right to alter the right of specifications

R-1050 AF SECTION