



SERVICEBLAD FÖR FÖRSTÄRKAR-
CHASSI TYP 6708
SERIE 1-2

LUXOR/RADIO

INGÅR I FÖLJANDE:

LUXOR SKANTIC
4788 S 3748

.....
.....

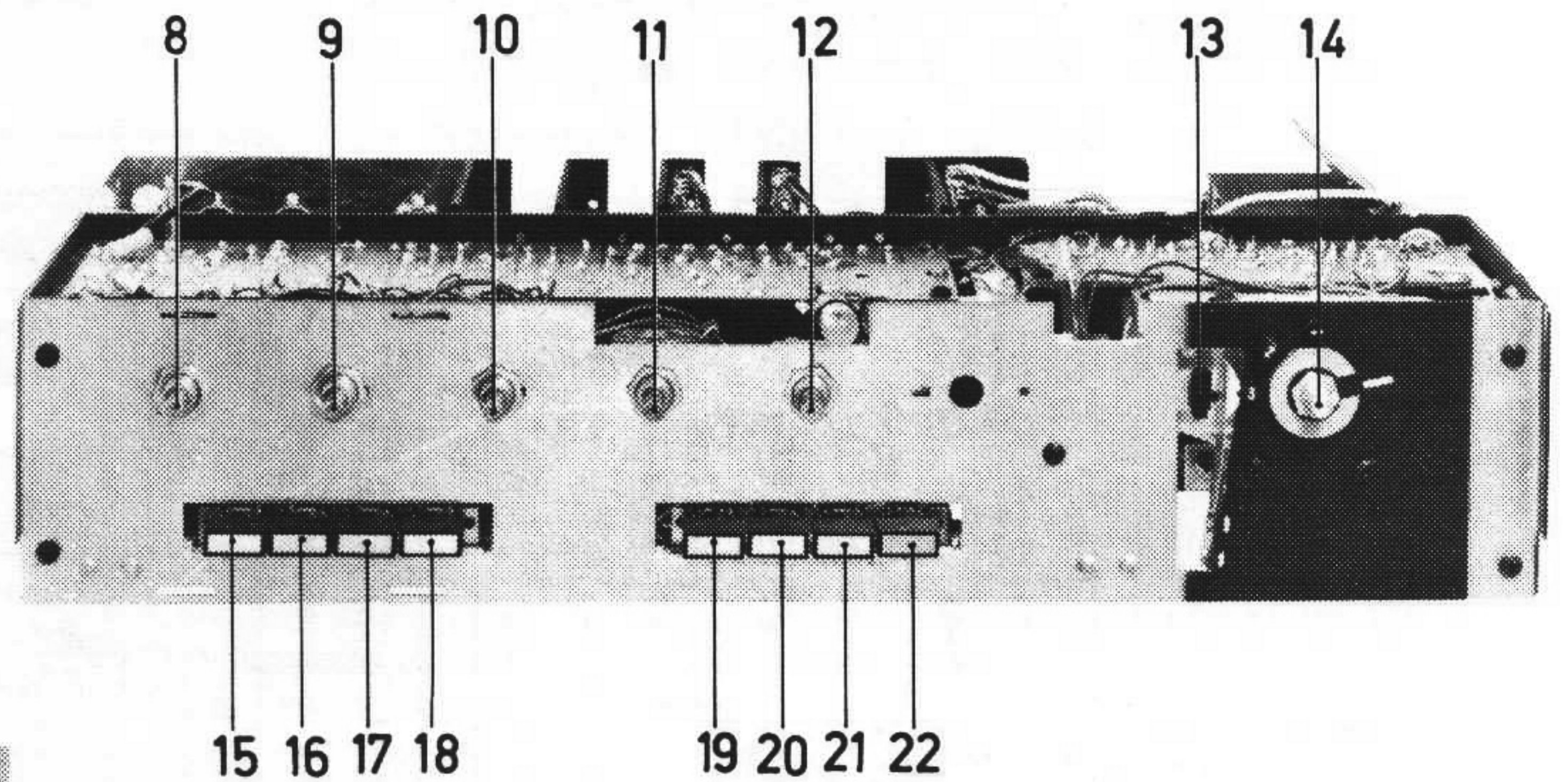
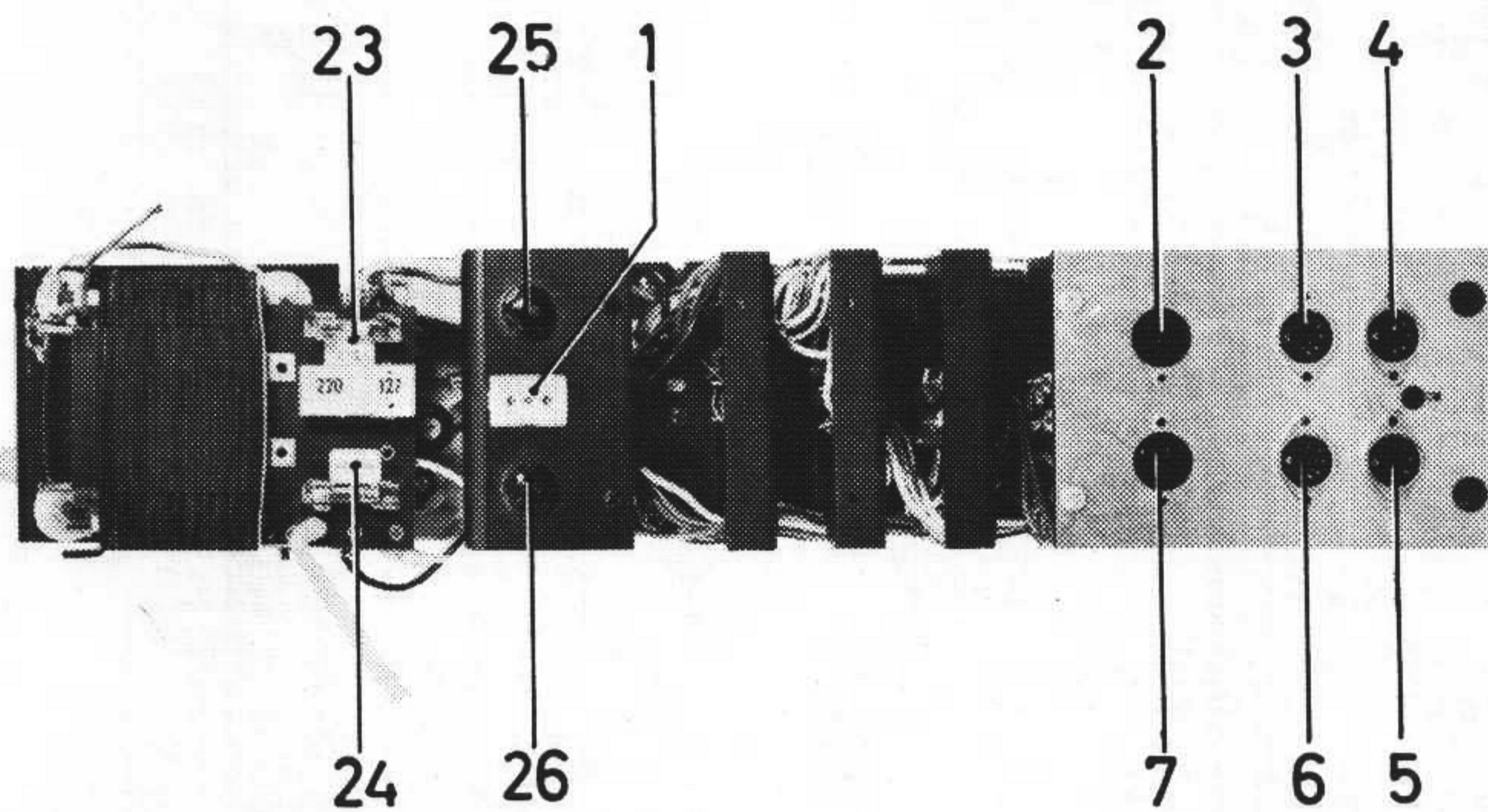

MARS 1968

TEKNISKA DATA

FREKVENSSOMRÅDE: 20 - 20.000 Hz \pm 2 dB
20 - 15.000 Hz \pm 1 dB
UTGÅNGSEFFEKT: 2 x 20 WATT
EFFEKT FÖRBRUKNING: 100 WATT
DYNAMIK: 70 dB
DISTORSION: VID 15 WATT UNDER 1 %
ÖVERHÖRNING: (KANALISOLATION) -50 dB
STÖRNIVÅ: -70 dB
UTGÅNGSIMPEDANS: 4 OHM
NÄTSPÄNNING: OMKOPPLINGSBAR 127-220 VOLT VÄXELSTRÖM
50 HZ

INGÅNGAR:	IMPEDANS:	KÄNSLIGHET:
MIKROFON	10 kOHM	1,5 mV
BANDSPELARE	47 kOHM	50 mV
KRISTALLPICKUP	470 kOHM	150 mV
MAGNETPICKUP	10 kOHM	4 mV

RADIODEL:
FREKVENSSOMRÅDE: 87 - 101 MHz
TRIMPUNKTER: 88 & 100 MHz
KÄNSLIGHET: CA 4 μ V VID 26 dB BRUSAVSTÅND
AUTOMATISK FREKVENSKONTROLL
INBYGGDA ÖVERSTYRNINGSDIODER
SELEKTOMAT SNABBVÄLJARE

BESTYCKNING:
TRANSISTORER:
4 ST BC 154, 4 ST AC 150, 3 ST AC 122, 2 ST BC 153,
2 ST AC 127, 2 ST AC 132, 4 ST AD 149, 1 ST TI 3027,
1 ST AC 117, 1 ST AF 106, 1 ST AF 125, 1 ST AF 137

DIODER:
2 ST BA 114, 1 ST BA 110, 2 ST OA 90, 2 ST AA 119,
1 ST OA 126/12

LIKRIKTARE:
1 ST KISELLIKRIKTARE B40 C2200
1 ST SELENLIKRIKTARE B30 C150

ANSLUTNINGAR:
1 UTTAG FÖR ANSLUTNING AV FM-ANTENN
2 UTTAG FÖR ANSLUTNING AV HÖGTALARE (HÖGER KANAL)
3 UTTAG FÖR ANSLUTNING AV KRISTALLPICKUP
4 UTTAG FÖR ANSLUTNING AV BANDSPELARE
5 UTTAG FÖR ANSLUTNING AV DYNAMISK STEREO MIKROFON
6 UTTAG FÖR ANSLUTNING AV MAGNETPICKUP
7 UTTAG FÖR ANSLUTNING AV HÖGTALARE (VÄNSTER KANAL)

MANÖVERORGAN:

- 8 VOLYMKONTROLL
 - 9 BASKONTROLL (+16 dB -12 dB VID 20 Hz)
 - 10 DISKANTKONTROLL (+11 dB -22 dB VID 20 kHz)
 - 11 BALANSKONTROLL (0 - MAX.)
 - 12 STRÖMBRYTARE
 - 13 LÅSKNAPP FÖR SELEKTOMAT
 - 14 STATIONSINSTÄLLNING FM (SELEKTOMAT)
 - 15 FM-OMKOPPLARE
 - 16 GRAMMOFONOMKOPPLARE
 - 17 BANDSPELAROMKOPPLARE
 - 18 MIKROFONOMKOPPLARE
 - 19 MONOOMKOPPLARE
- FILTERVÄLJARE:**
- 20 BASAVSKÄRNING -11 dB VID 20 Hz
 - 21 SÄNKNING AV MELLANREGISTER -4 dB VID 1000 Hz
 - 22 DISKANTAVSKÄRNING -12 dB VID 20 kHz

SÄKRINGAR:

- 23 FINSÄKRING 4 AMP
- 24 FINSÄKRING 160 mA
- 25 FINSÄKRING 1,6 AMP
- 26 FINSÄKRING 1,6 AMP

KOPPLINGSSCHEMA CIRCUIT DIAGRAM

Endast vänster kanal är ritad
H=går till höger kanal
Only left channel shown
H=leading to right channel

BC154 BC154 AC150 AC150 AC12

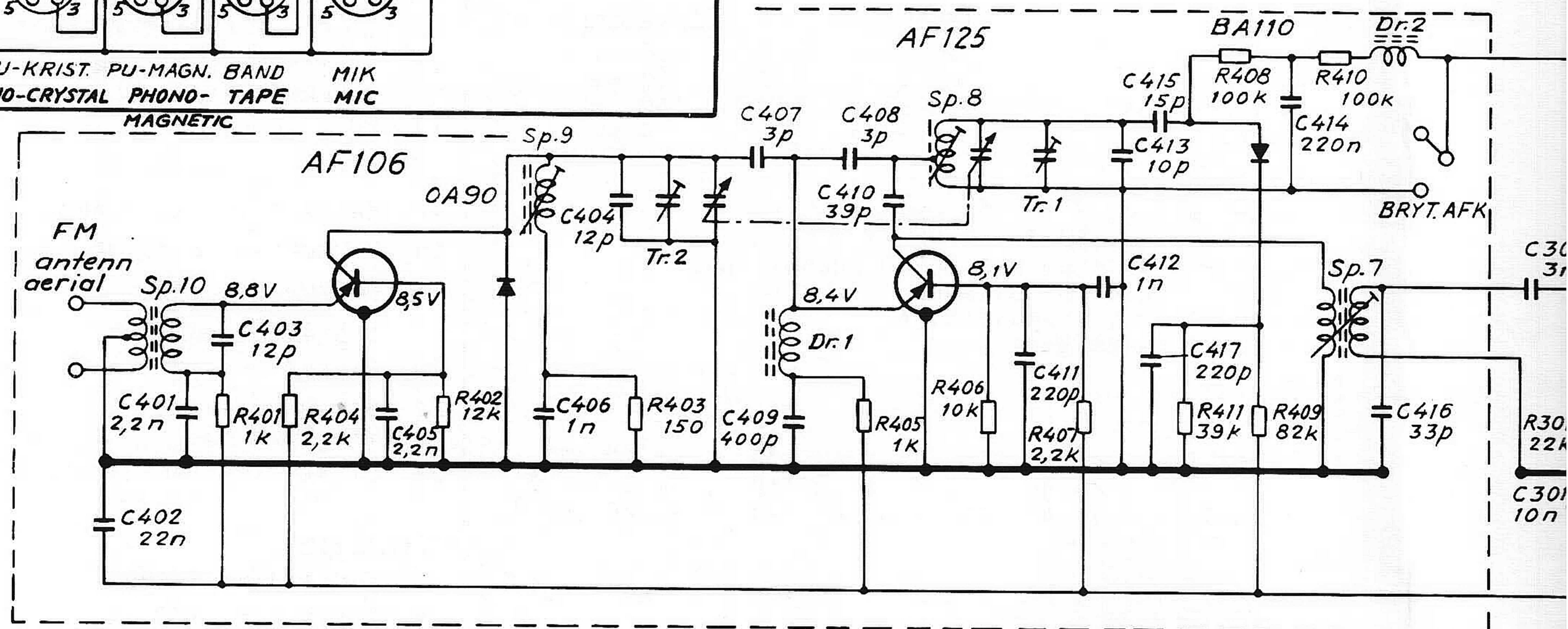
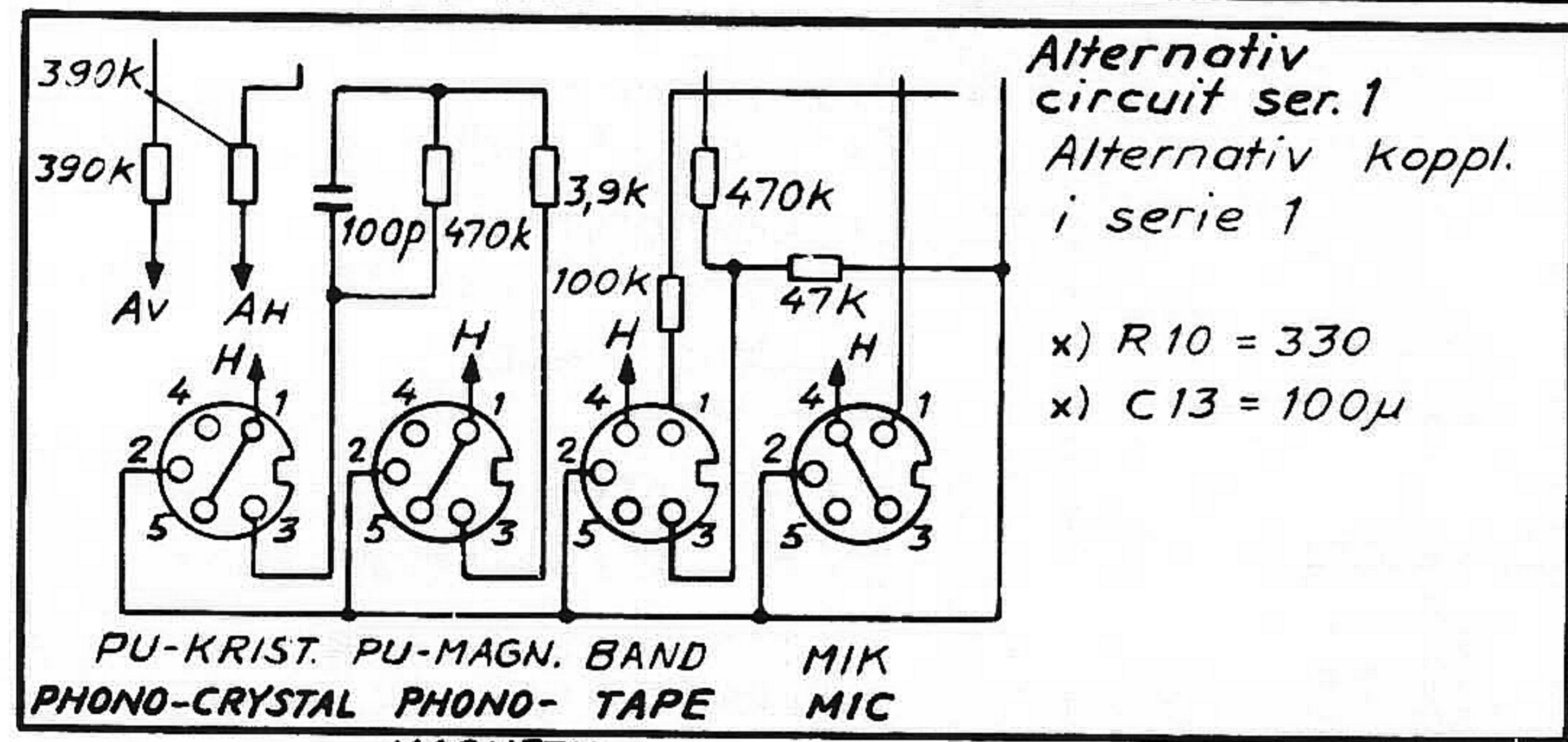
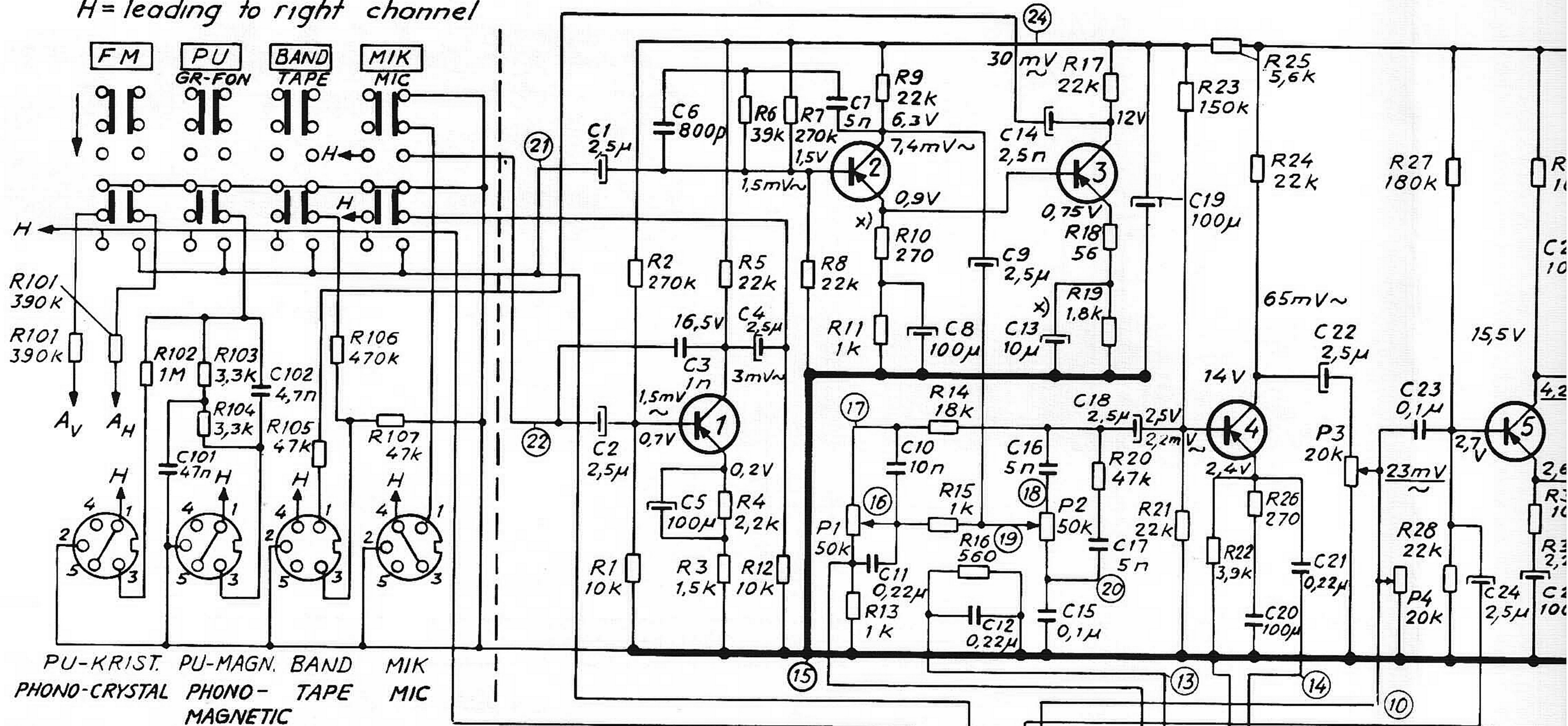

SIGNALSPÄNNINGARNA ÄRO MÄTTA MED RÖRVOLTMETER. DE UNDERSTRUKNA ANGER RIKTVÄRDE FÖR 15 WATT UT, 1000 P/S. ALLA LIKSPÄNNINGAR MÄTTA UTAN SIGNAL GENOM FÖRSTÄRKAREN. POT. P 6 INSTÄLLES SÅ ATT SPÄNNINGEN MELLAN 1 O. 6 UTGÖR UNGEFÄR HALVA SPÄNNINGEN AV DEN SOM LIGGER MELLAN 1 O. 9. FINJUSTERING AV P 6 SKER PÅ FÖLJANDE SÄTT: ANSLUT EN OSCILLOGRAF ÖVER HÖGTALARUTGÅNGEN SOM SOM SKALL VÄRA BELASTAD MED 4 OHM. INMATA SEDAN 1000 P/S SIGNAL PÅ INGÅNGEN AV SÅDAN STORLEK ATT JUST KLIPPNING BÖRJAR SYNAS PÅ OSCILLOGRAFEN, FINJUSTERA P 6 SÅ ATT KLIPPNINGEN BLIR SYMMETRISK.

POT. P 5 INSTÄLLES SÅ ATT VILOSTRÖMMEN GENOM TRANSISTORERNA AD 149 BLIR CA 50 mA ELLER ATT CA 20 mV ERHÅLLES ÖVER MOTSTÅNDET R 45. VOLYMKONTROLLEN SKALL UNDER INSTÄLLNINGEN STÅ PÅ 0.

SMÄRRE AVVIKELSER FRÅN SCHEMAT KAN FÖREKOMMA PÅ GRUND AV ÄNDRINGAR FÖRETAGNA UNDER PRODUKTIONEN.

SIGNAL VOLTAGES MEASURED WITH VALVE VOLTMETER. THE UNDERLINED ONES STATE NOMINAL VALUE FOR 15 W OUTPUT, 1000 c/s. ALL DC VOLTAGES MEASURED WITHOUT SIGNAL THROUGH AMPLIFIER. POTENTIOMETER P 6 TO BE ADJUSTED SO THAT VOLTAGE BETWEEN 1 AND 6 IS APPROX. HALF THE VOLTAGE BETWEEN 1 AND 9. FINE ADJUSTMENT OF P 6 IN THE FOLLOWING WAY: CONNECT OSCILLOGRAPH VIA LOUDSPEAKER SOCKET LOADED WITH 4 OHMS. FEED SIGNAL (1000 c/s) TO AMPLIFIER INPUT WITH SUCH A SIZE THAT CLIPPING JUST APPEARS ON THE OSCILLOGRAPH. FINE ADJUST P 6 SO THAT CLIPPING BECOMES SYMMETRIC

POT. P 5 TO BE SET SO THAT SPACING CURRENT THROUGH TRANSISTORS AD 149 BECOMES APPROX. 50 mA OR THAT APPROX. 20 mV ARE OBTAINED ACROSS RESISTOR R 45. VOLUME CONTROL IN 0-POSITION.

MINOR DEVIATIONS FROM THE CIRCUIT DIAGRAM CAN OCCUR DUE TO ALTERATIONS INTRODUCED DURING PRODUCTION.

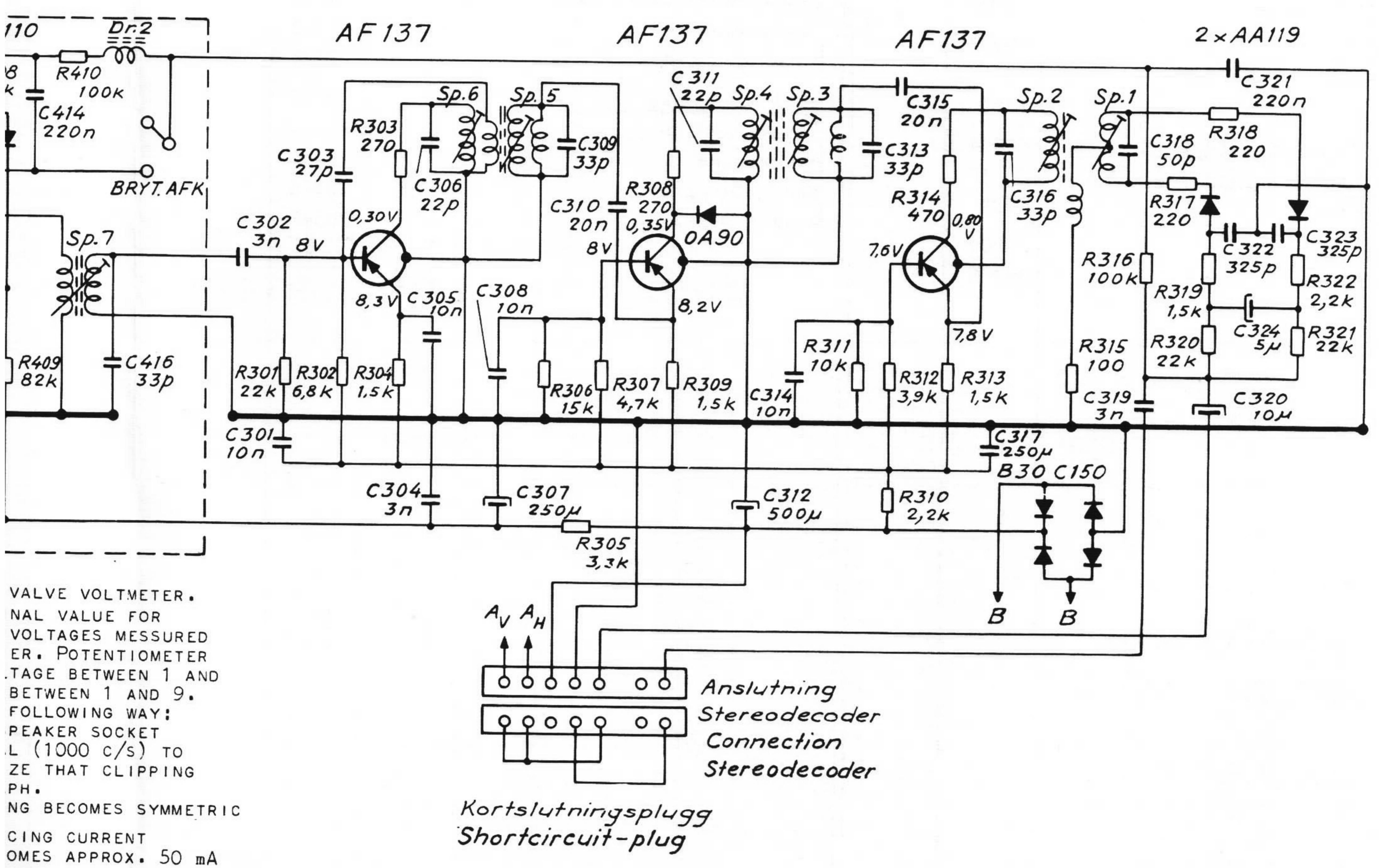
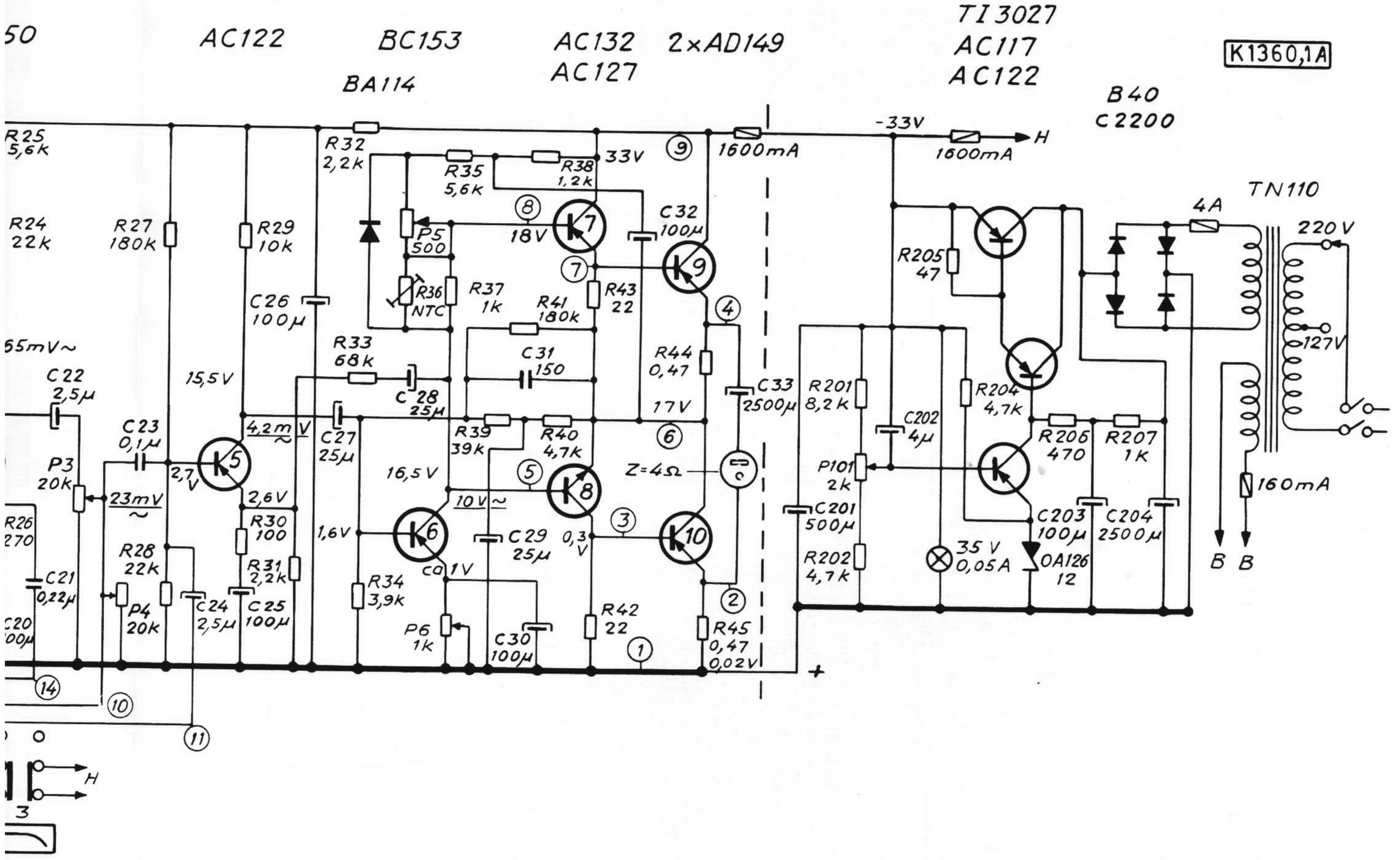

VALVE VOLTMETER.
 VAL VALUE FOR
 VOLTAGES MEASURED
 ER. POTENTIOMETER
 TAGE BETWEEN 1 AND
 BETWEEN 1 AND 9.
 FOLLOWING WAY:
 PEAKER SOCKET
 L (1000 c/s) TO
 ZE THAT CLIPPING
 PH.
 NG BECOMES SYMMETRIC
 CING CURRENT
 OMES APPROX. 50 mA
 INED ACROSS
 IN 0-POSITION.
 UIT DIAGRAM CAN
 DUCED DURING

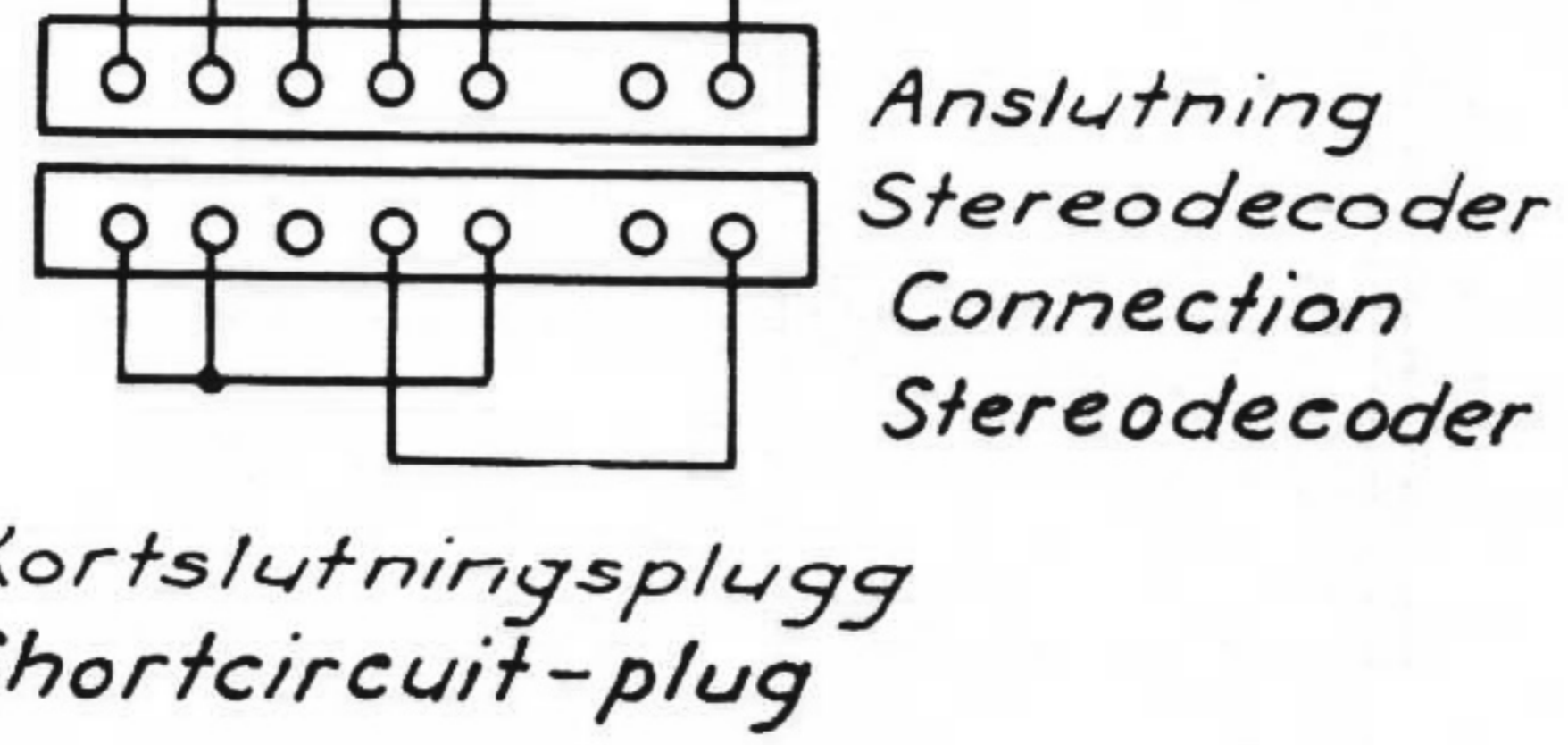

Motstånd (R) Resistors
Stora Plattan Large board

Nr	Värde	Tol±%	Mat.	Bel.w	Det.nr
1	10 kΩ	5	Keram.	1/8	29265 A
2	270 kΩ	5	Kerbrusfri	1/4	29507 A
3	15 kΩ	5	Glas kol	1/2	29127
4	2,2 kΩ	5	"	1/2	20624
5	22 kΩ	5	Kerbrusfri	1/4	29506 A
6	39 kΩ	5	Glas kol	1/2	20140
7	270 kΩ	5	Kerbrusfri	1/4	29507 A
8	22 kΩ	5	"	1/4	29506 A
9	22 kΩ	5	"	1/4	29506 A
10	270 Ω	5	Glas kol	1/2	20009
11	1 Ω	5	"	1/2	20942
12	10 kΩ	5	Keram.	1/8	29265 A
13	1 kΩ	5	Glas kol	1/2	20942
14	18 kΩ	5	"	1/2	20342
15	1 kΩ	5	"	1/2	20942
16	560 Ω	5	"	1/2	29406
17	22 kΩ	5	Kerbrusfri	1/4	29506 A
18	56 Ω	5	Glas kol	1/2	29175
19	18 kΩ	5	"	1/2	20127
20	47 kΩ	5	"	1/2	29219
21	22 kΩ	5	Kerbrusfri	1/4	29506 A
22	39 kΩ	5	Glas kol	1/2	20128
23	150 kΩ	5	Keram.	1/8	29275 A
24	22 kΩ	5	Kerbrusfri	1/4	29506 A
25	56 kΩ	5	Glas kol	1/2	20129
26	270 kΩ	5	"	1/2	20009
27	180 kΩ	5	"	1/2	29130
28	22 kΩ	5	Kerbrusfri	1/4	29506 A
29	10 kΩ	5	Keram.	1/8	29265 A
30	100 Ω	5	Glas kol	1/2	29295
31	22 kΩ	5	"	1/2	20624
32	2,2 kΩ	5	"	1/2	20624
33	68 kΩ	5	"	1/2	29116
34	39 kΩ	5	"	1/2	20128
35	5,6 kΩ	5	"	1/2	20129
36	500 Ω		N.T.C.		29461
37	1 kΩ	5	Glas kol	1/2	20942
38	1,2 kΩ	5	"	1/2	20676
39	39 kΩ	5	"	1/2	20140
40	47 kΩ	5	"	1/2	20946
41	180 kΩ	5	"	1/2	29130
42	22 Ω	5	"	1/2	29281
43	22 Ω	5	"	1/2	29281
44	0,47 Ω	5	Trädlinj.	3	29519
45	0,47 Ω	5	"	3	29519
P5	500 Ω		Regl. pot.		17506
P6	1 kΩ		"		17488

Ingångsdel Inputstage

Nr	Värde	Tol±%	Mat.	Bel.w	Det.nr
101	390 kΩ	5	Massa	1/4	29435
102	1 MΩ	10	"	1/4	20370
103	33 kΩ	10	"	1/4	29419
104	3,3 kΩ	10	"	1/4	29419
105	47 kΩ	10	"	1/4	29231
106	470 kΩ	5	"	1/4	20956
107	47 kΩ	10	"	1/4	29231

Kondensatorer (C) Condensers
Stora Plattan Large board

Nr	Värde	Tol±%	Mat.	Sp.V	Det.nr
1	2,5 μF		Elyt	64	21101
2	55 μF		"	64	21101
3	1 nF	10	Styrol	63	21846
4	2,5 μF		Elyt	64	21101
5	100 μF		"	12/15	21666
6	800 pF	5	Styrol	63	21793
7	5 nF	10	"	63	21847
8	100 μF		Elyt	12/15	21666
9	2,5 μF		"	64	21864
10	10 nF	10	Polyest.	400	21864
11	0,22 μF	10	"	160	21742 B
12	0,22 μF	10	"	160	21742 B
13	10 μF		Elyt	16	20961
14	2,5 μF		"	64	21101
15	0,1 μF	10	Polyest.	160	12614 B
16	55 nF	10	Styrol	63	21847
17	55 nF	10	"	63	21847
18	2,5 μF		Elyt	64	21101
19	100 μF		"	35	21114
20	100 μF		"	12/15	21666
21	0,22 μF	10	Polyest.	160	21742 B
22	2,5 μF		Elyt	64	21101
23	0,1 μF	10	Polyest.	160	12614 B
24	2,5 μF		Elyt	64	21101
25	100 μF		"	12/15	21666
26	100 μF		"	35	21114
27	25 μF		"	25	21801
28	25 μF		"	25	21801
29	25 μF		"	25	21801
30	100 μF		"	12/15	21666
31	150 pF	10	Keram.	500	21281
32	100 μF		Elyt	35	21114
33	2500 μF		"	35/40	21141

Ingångsdel Inputstage

Nr	Värde	Tol±%	Mat.	Sp.V	Det.nr
101	47 nF	10	Polyest.	160	12613 B
102	47 nF	5	Styrol	63	12649

Likriktardel Rectifiers

Nr	Värde	Tol±%	Mat.	Sp.V	Det.nr
201	500 μF		Elyt	35/40	21582
202	4 μF		"	40	21667 B
203	100 μF		"	35	21114
204	2500 μF		"	64	12688

Motstånd (R) Resistors
UKW-enhet FM-unit

Nr	Värde	Tol±%	Mat.	Bel.w	Det.nr
401	1 kΩ	5	Keram.	1/8	29258 A
402	12 kΩ	5	"	1/8	29266 A
403	150 Ω	5	Glas kol	1/2	20938
404	2,2 kΩ	5	Keram.	1/8	29260 A
405	1 kΩ	5	"	1/8	29258 A
406	10 kΩ	5	"	1/8	29265 A
407	2,2 kΩ	5	"	1/8	29260 A
408	100 kΩ	5	"	1/8	29274 A
409	82 kΩ	5	"	1/8	29298 A
410	100 kΩ	5	"	1/8	29274 A
411	39 kΩ	5	"	1/8	29271 A

MF-delen IF-stage

Nr	Värde	Tol±%	Mat.	Bel.w	Det.nr
301	22 kΩ	5	Glas kol	1/2	20950
302	6,8 kΩ	5	Massa	1/4	29234
303	270 Ω	5	Glas kol	1/2	20009
304	1,5 kΩ	5	"	1/2	29127
305	3,3 kΩ	5	"	1/2	29129
306	15 kΩ	5	"	1/2	20949
307	4,7 kΩ	5	"	1/2	20946
308	270 Ω	5	"	1/2	20009
309	1,5 kΩ	5	"	1/2	29127
310	2,2 kΩ	5	"	1/2	20624
311	10 kΩ	5	"	1/2	20136
312	3,9 kΩ	5	"	1/2	20128
313	1,5 kΩ	5	"	1/2	29127
314	470 Ω	5	"	1/2	20975
315	100 Ω	5	"	1/2	29295
316	100 kΩ	5	"	1/2	20885
317	220 Ω	5	"	1/2	29111
318	220 Ω	5	"	1/2	29111
319	1,5 kΩ	5	"	1/2	29127
320	22 kΩ	5	"	1/2	20950
321	22 kΩ	5	"	1/2	20950
322	2,2 kΩ	5	"	1/2	20624

Likriktardel Rectifiers

Nr	Värde	Tol±%	Mat.	Bel.w	Det.nr
201	8,2 kΩ	5	Glas kol	1/2	20130
202	4,7 kΩ	5	"	1/2	20946
204	4,7 kΩ	5	Glas kol	1/2	20946
205	47 Ω	5	"	1/2	29277
206	470 Ω	5	"	1/2	20975
207	1 kΩ	5	"	1/2	20942
P101	2 kΩ		Regl. pot.		17396

Kondensatorer (C) Condensers
UKW-enhet FM-unit

Nr	Värde	Tol±%	Mat.	Sp.V	Det.nr
401	2,2 nF	+50-20	Keram.	500	21147
402	22 nF	-20+100	"	30	21993
403	12 pF	±0,5pF	"	500	21277
404	12 pF	±0,5pF	"	500	21277
405	2,2 nF	+50-20	"	500	21147
406	1 nF	2,5	Styrol	24	21870
407	3 pF	±0,5pF	Keram.	500	21449
408	3 pF	±0,5pF	"	500	21449
409	400 pF	2,5	Styrol	25	21721
410	39 pF	2,5	Keram.	250	21844
411	220 pF	2,5	Styrol	24	21868
412	1 nF	2,5	"	24	21870
413	10 pF	2,5	Keram.	500	21948
414	220 nF	2,5	Polyest.	30	21730
415	15 pF	5	Keram.	500	21830
416	39 pF	2,5	Styrol	250	21844
417	220 pF	2,5	"	24	21868

MF-delen IF-stage

Nr	Värde	Tol±%	Mat.	Sp.V	Det.nr
301	10 nF	10	Styrol	63	21841
302	3 nF	2,5	"	63	21840
303	27 pF	2	Keram.	30	12657
304	3 nF	2,5	Styrol	63	21840
305	10 nF	10	"	63	21841
306	22 pF	5	Keram.	500	21489
307	250 μF		Elyt	16	12631
308	10 nF	10	Papper	240	21726
309	33 pF	5	Keram.	500	21478
310	20 nF	10	Papper	125	21842
311	22 pF	5	Keram.	500	21849
312	500 μF		Elyt	25	21724
313	33 pF	5	Keram.	500	21478
314	10 nF	10	Papper	250	21726
315	20 nF	10	"	125	21842
316	33 pF	5	Keram.	500	21478
317	250 μF		Elyt	16	12631
318	50 pF	2,5	Styrol	125	21960
319	3 nF	2,5	"	63	21840
320	10 μF		Elyt	12	21961
321	220 nF	20	Polyest.	125	21742
322	325 pF	2,5	Styrol	125	21897
323	325 pF	2,5	"	125	21897
324	5 μF		Elyt	25	21724

Potentiometrar Potentiometers

Nr	Värde	Det.nr
P1	50 kΩ log	17573
P2	50 kΩ log	17573
P3	20 kΩ log	17568
P4	20 kΩ lin	17567

K 1360,2

Förstärkarplatta (övre) vänster kanal

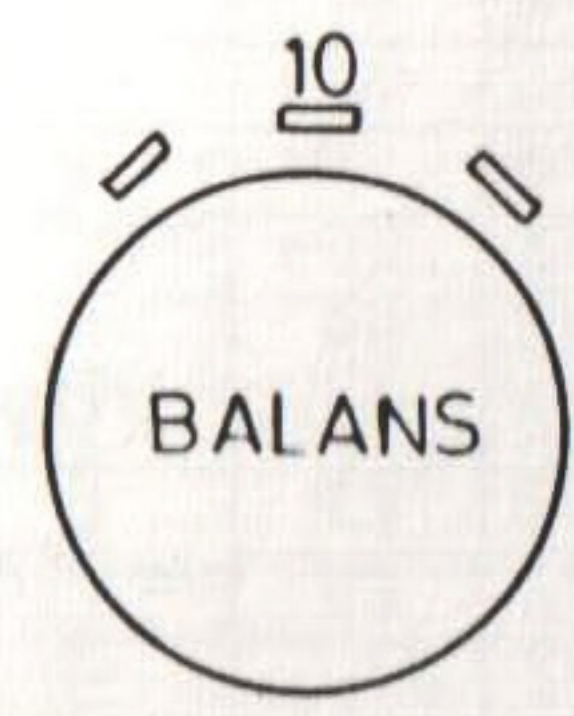
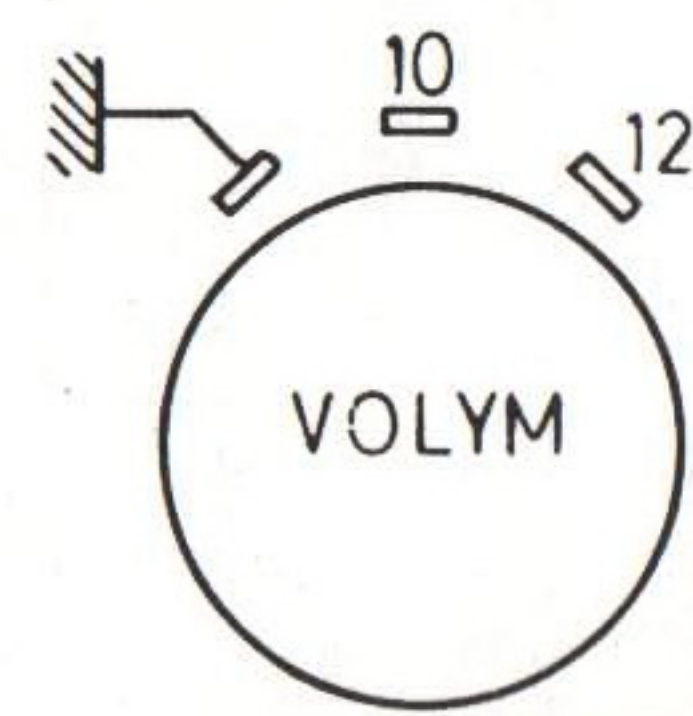
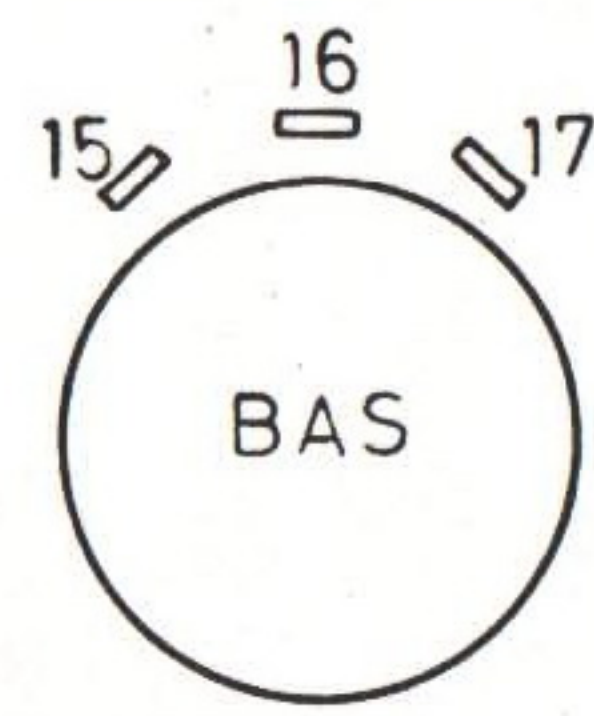
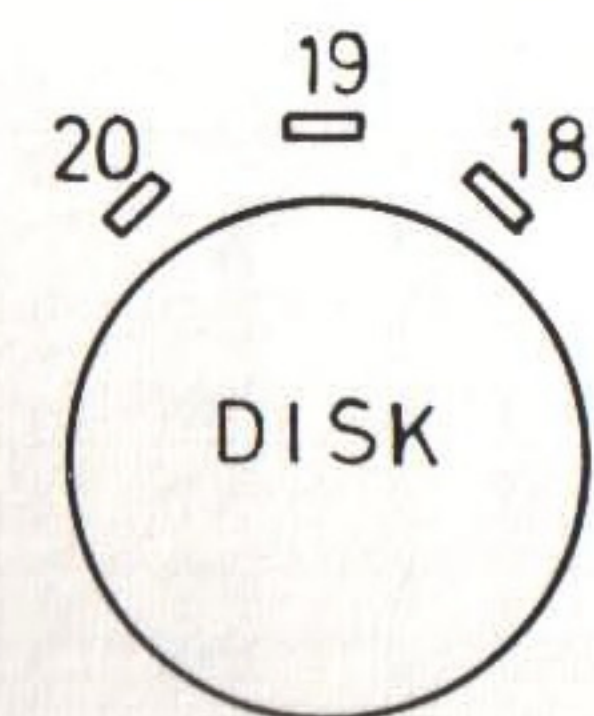
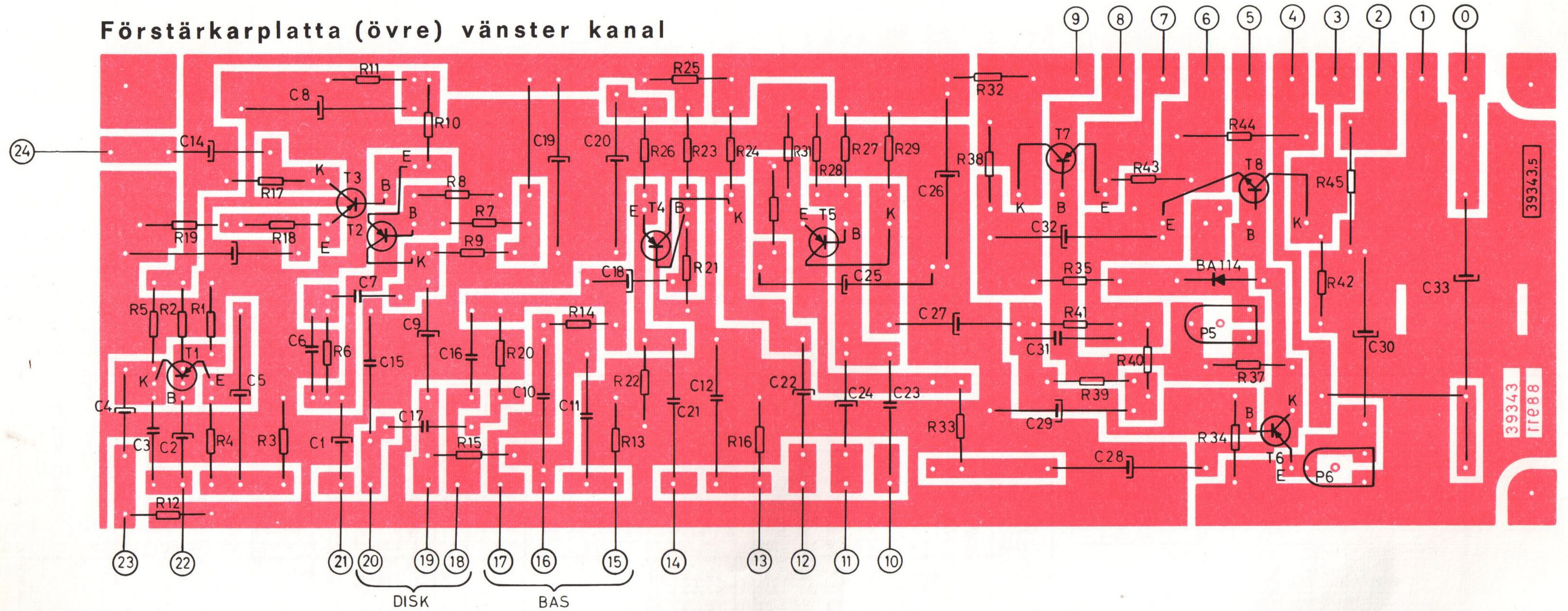

- | | |
|----------|-------|
| Filter 1 | 10-11 |
| " 2 | 13-15 |
| " 3 | 14-⏏ |

Kontrollerna sedda bakifrån

39343,5

39343
rre88

Förstärkarplatta (undre) höger kanal

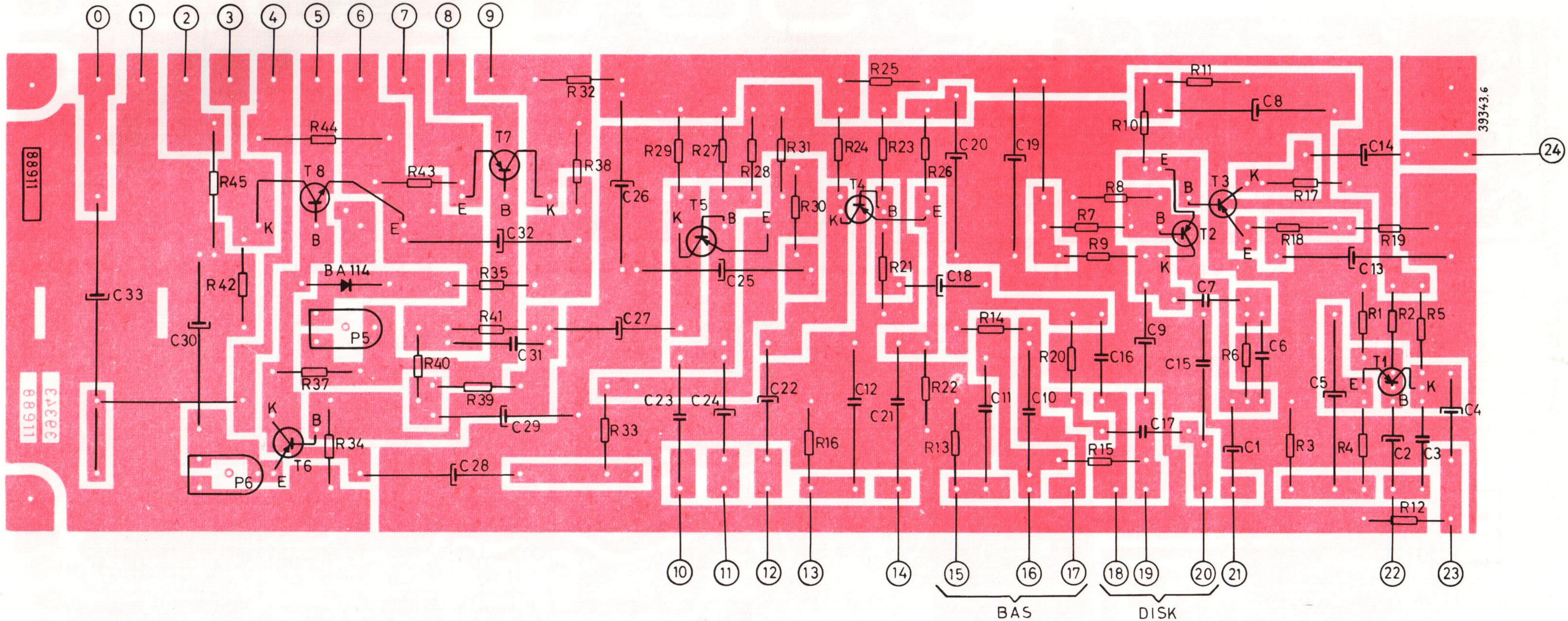

MF-platta

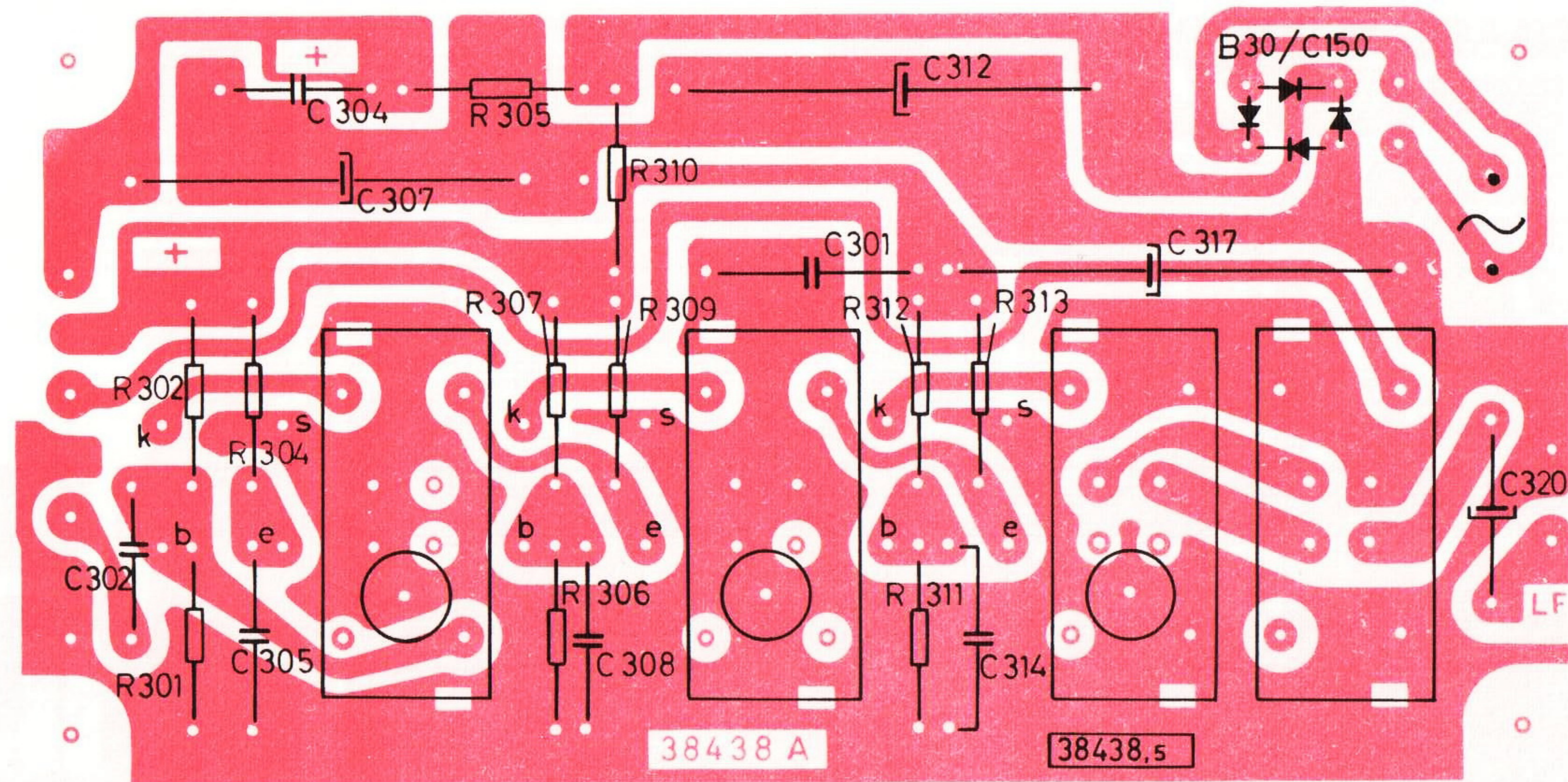

Likriktarplatta

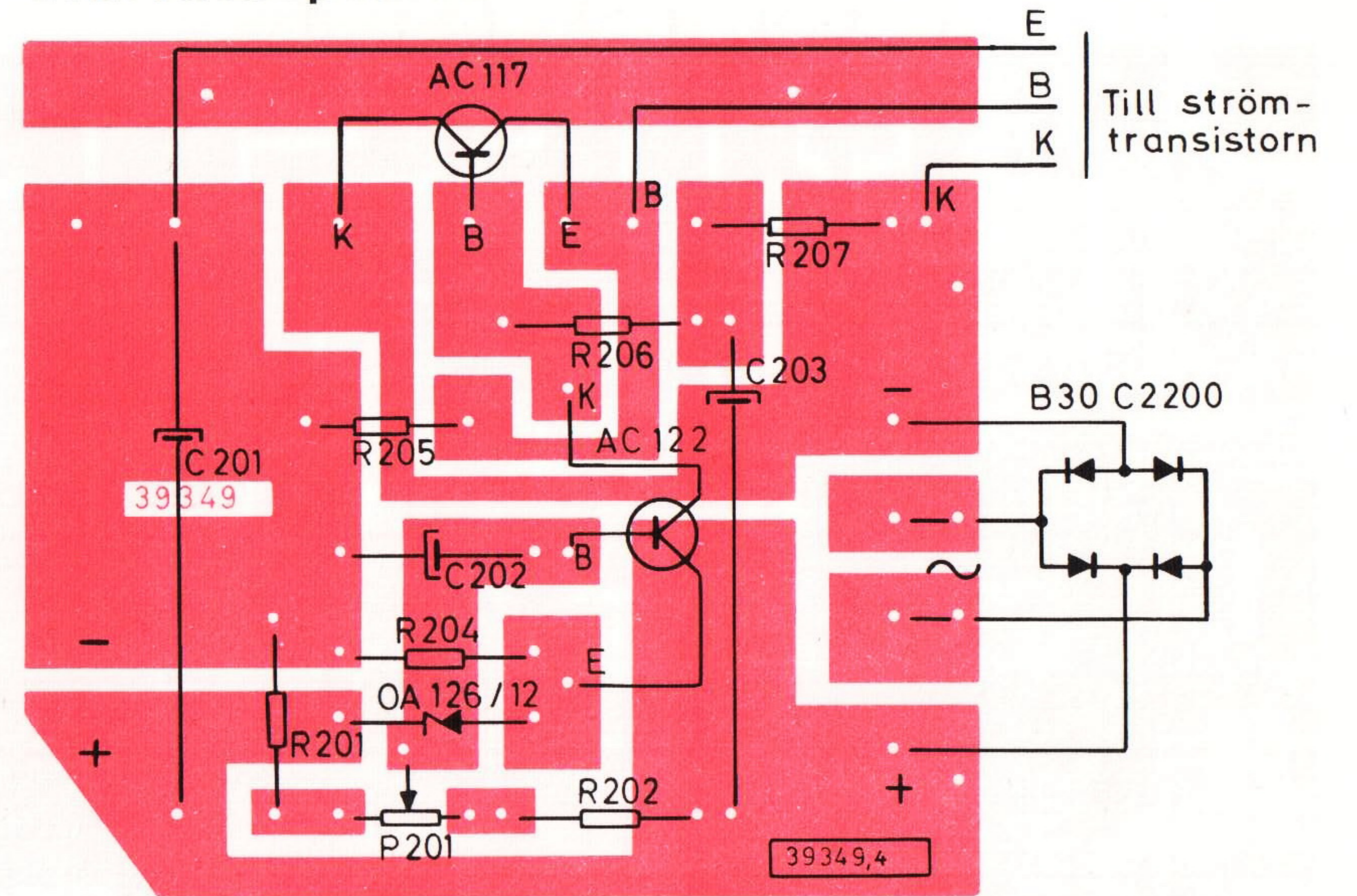

Ingångsplatta, serie 1

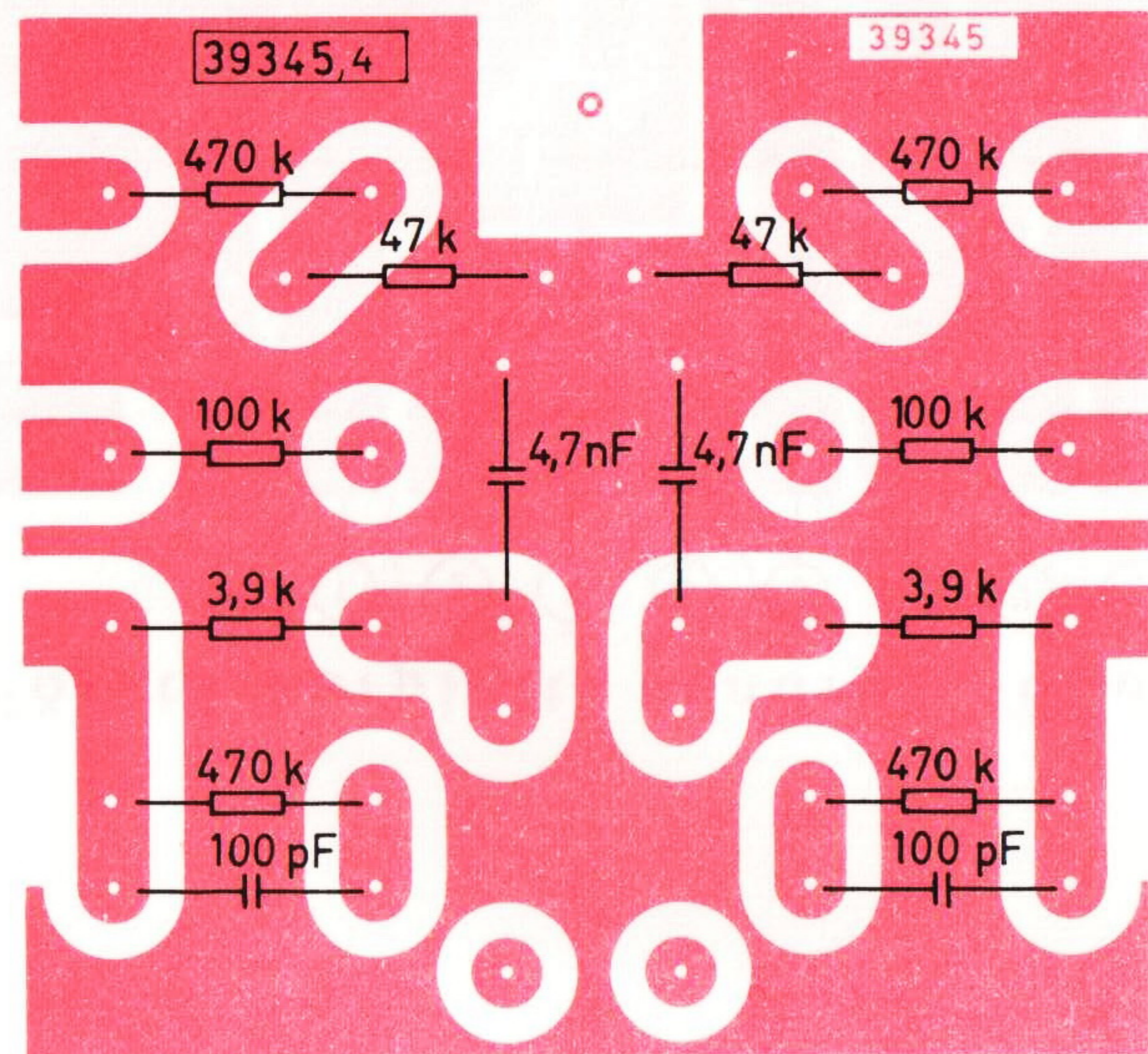

Ingångsplatta, serie 2

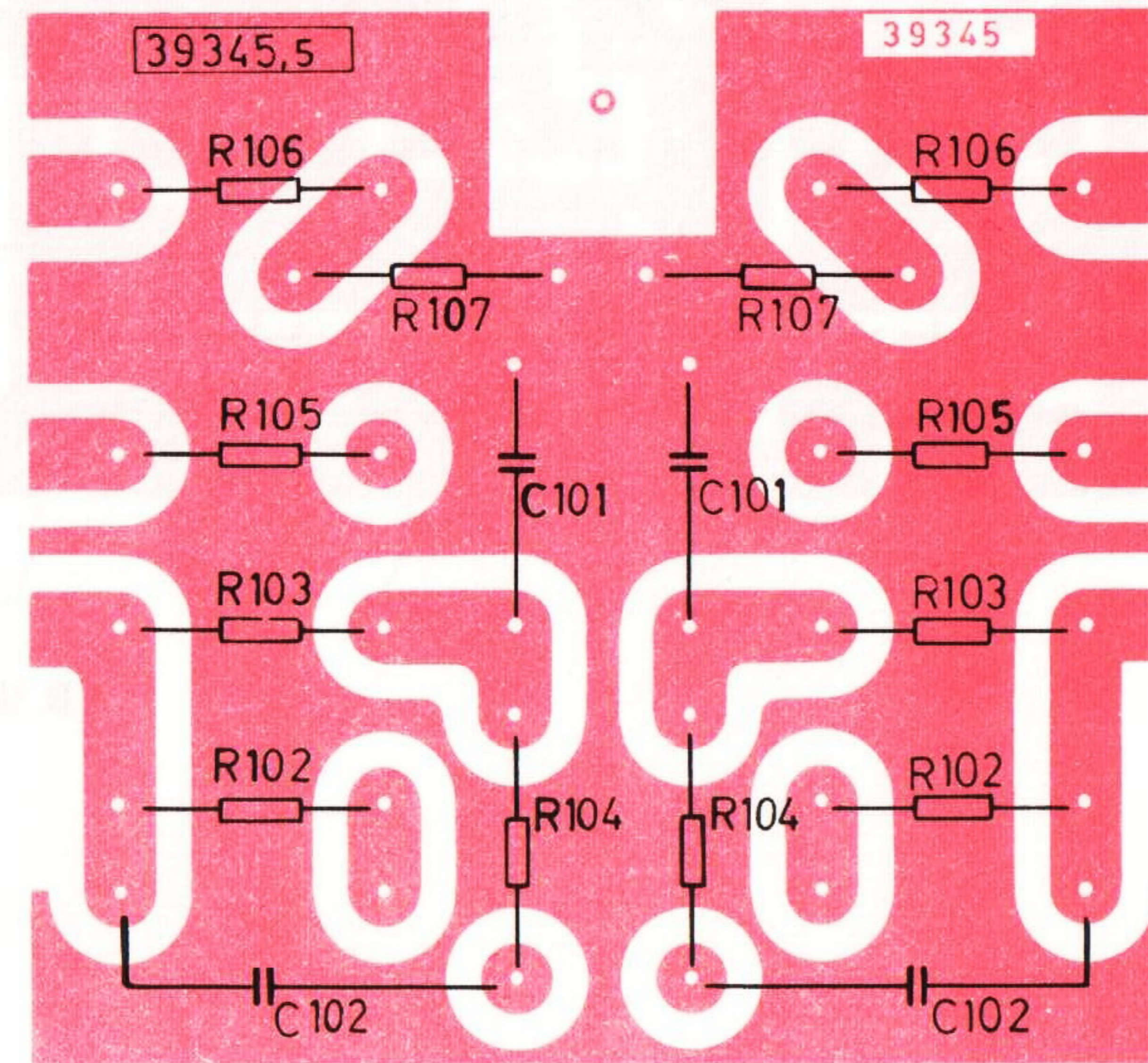

UKV-platta

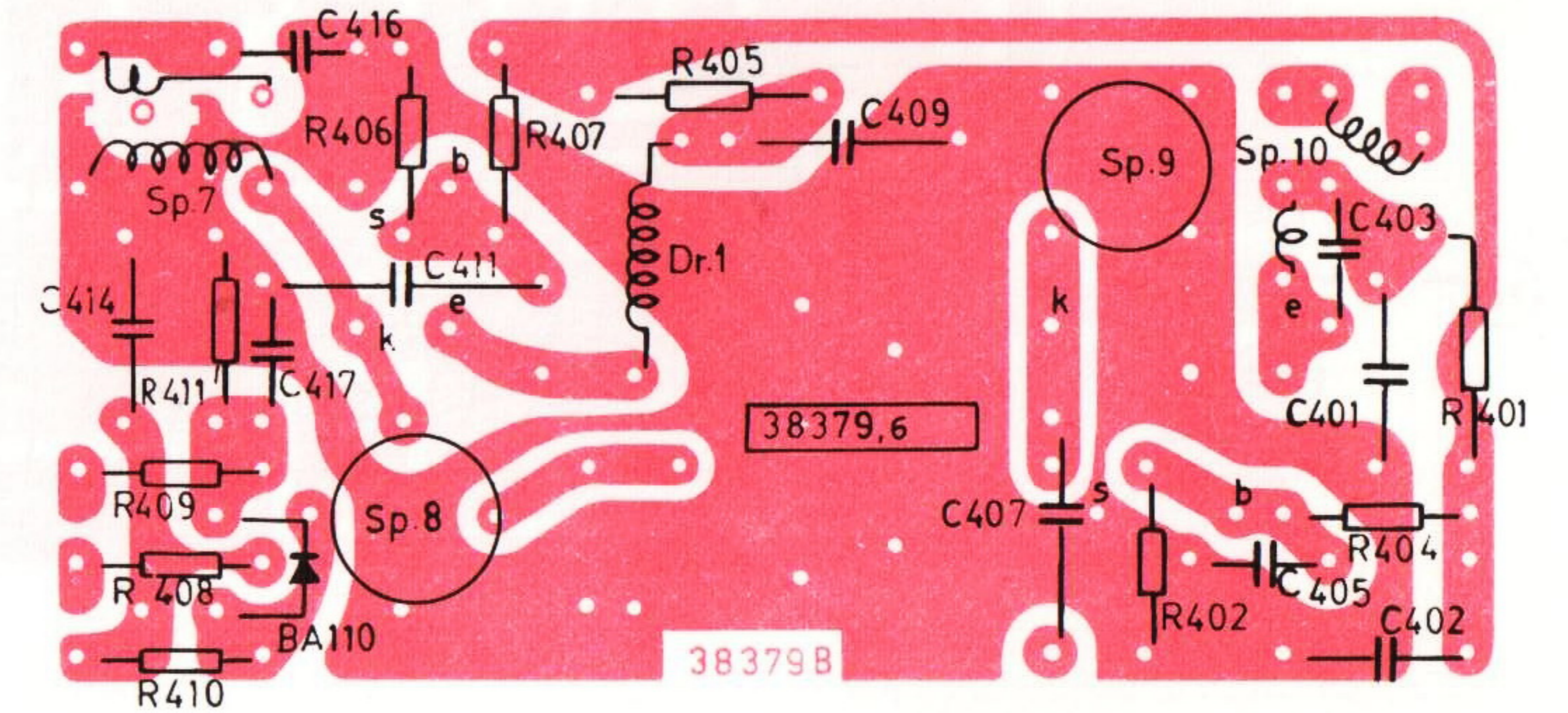

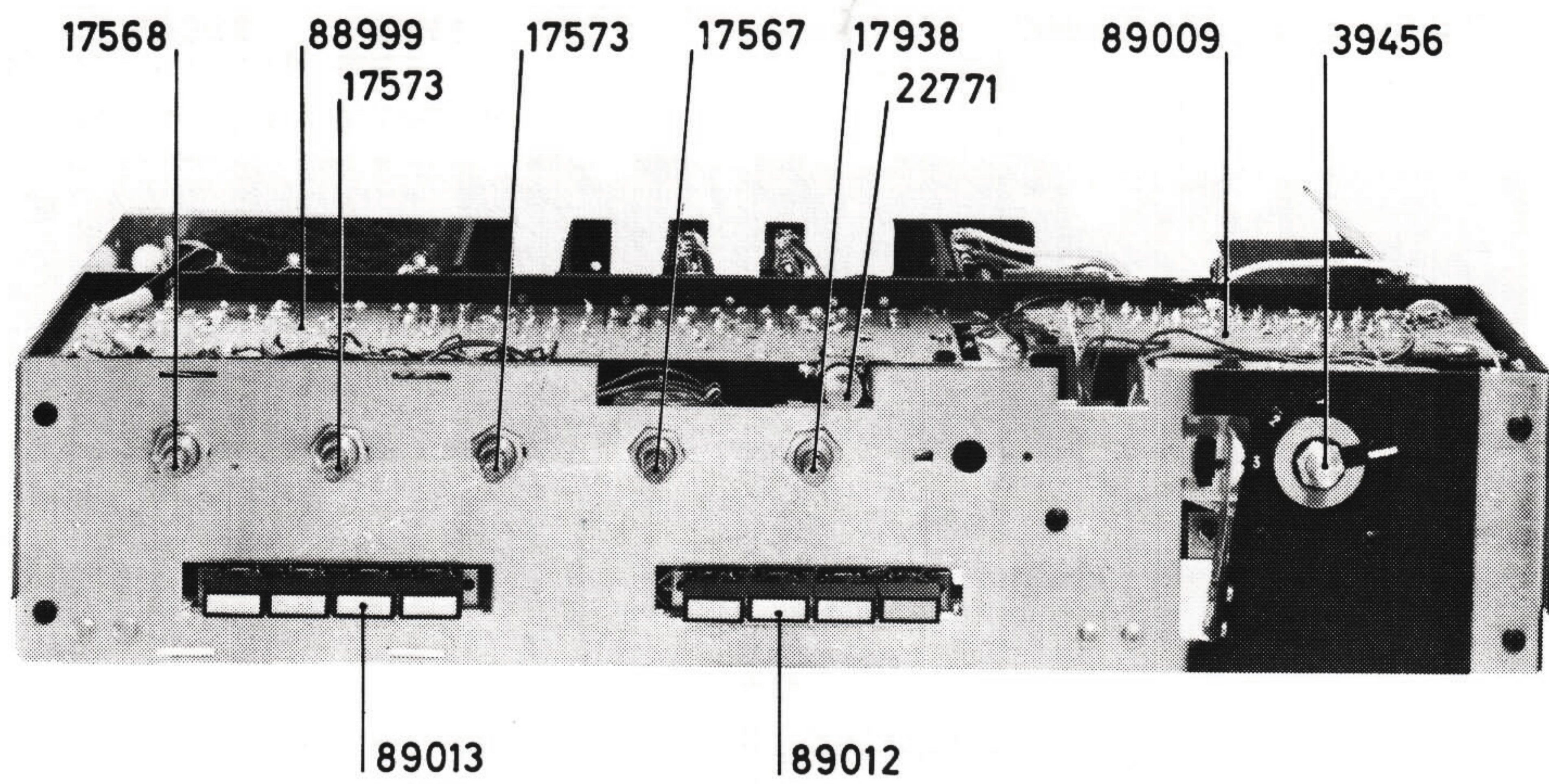

Fig.1

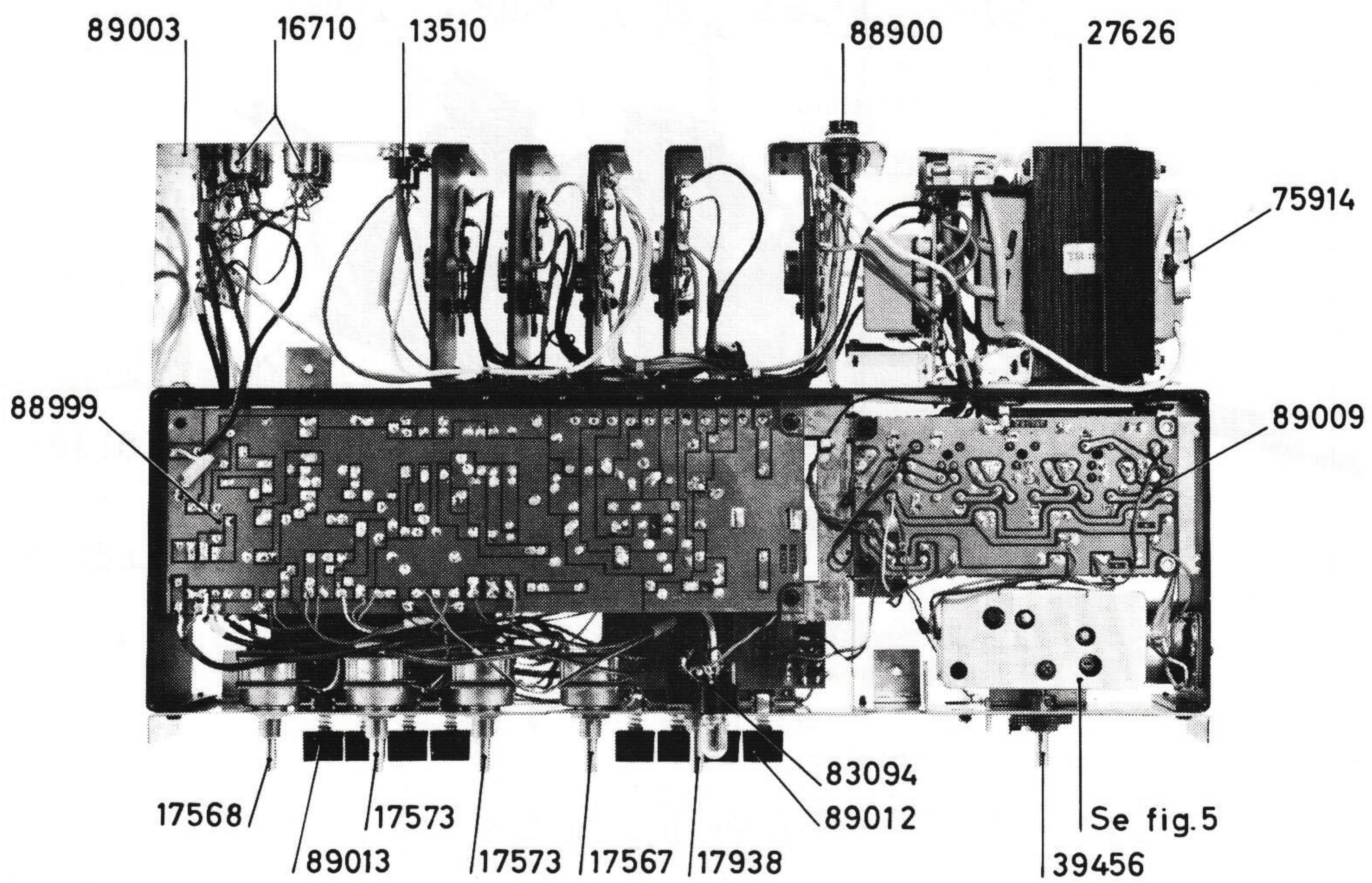

Fig.2

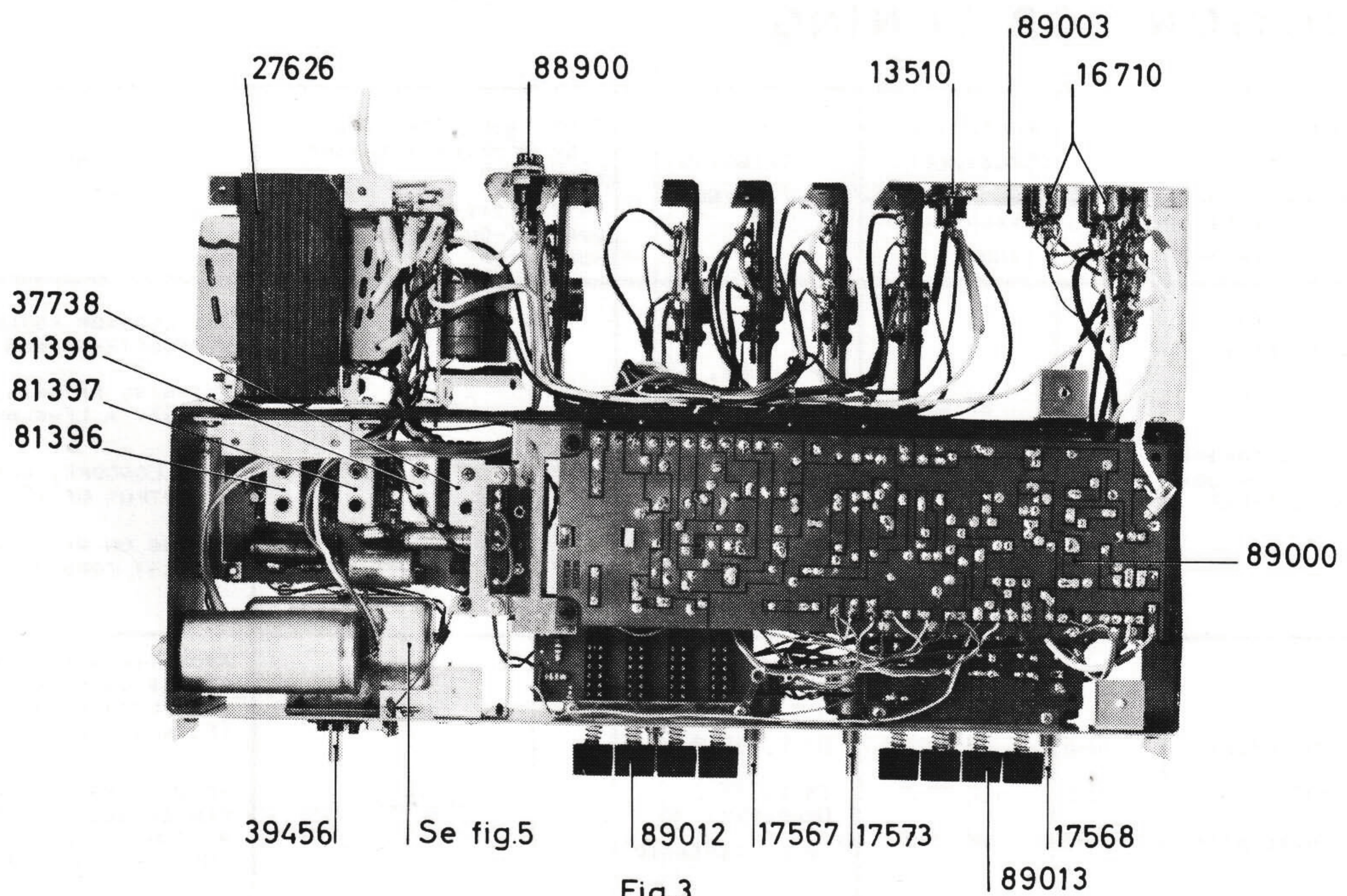

Fig.3

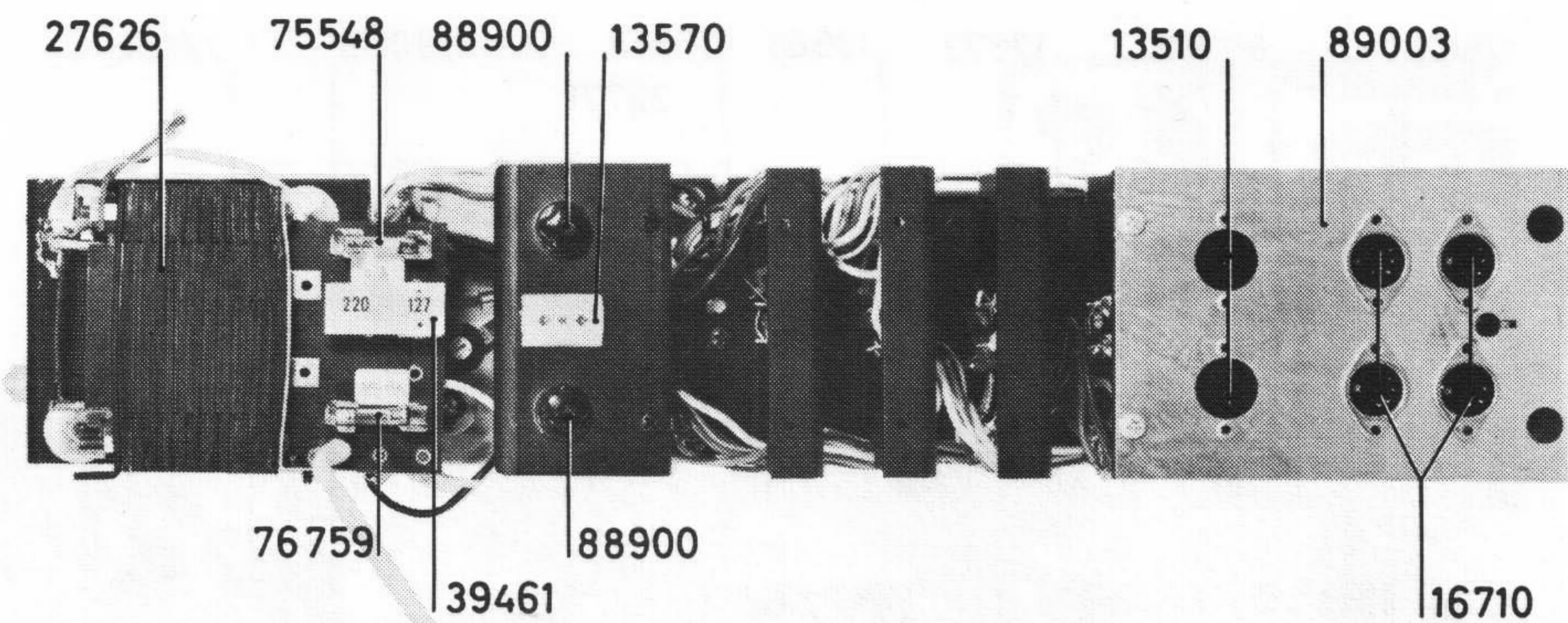

Fig.4

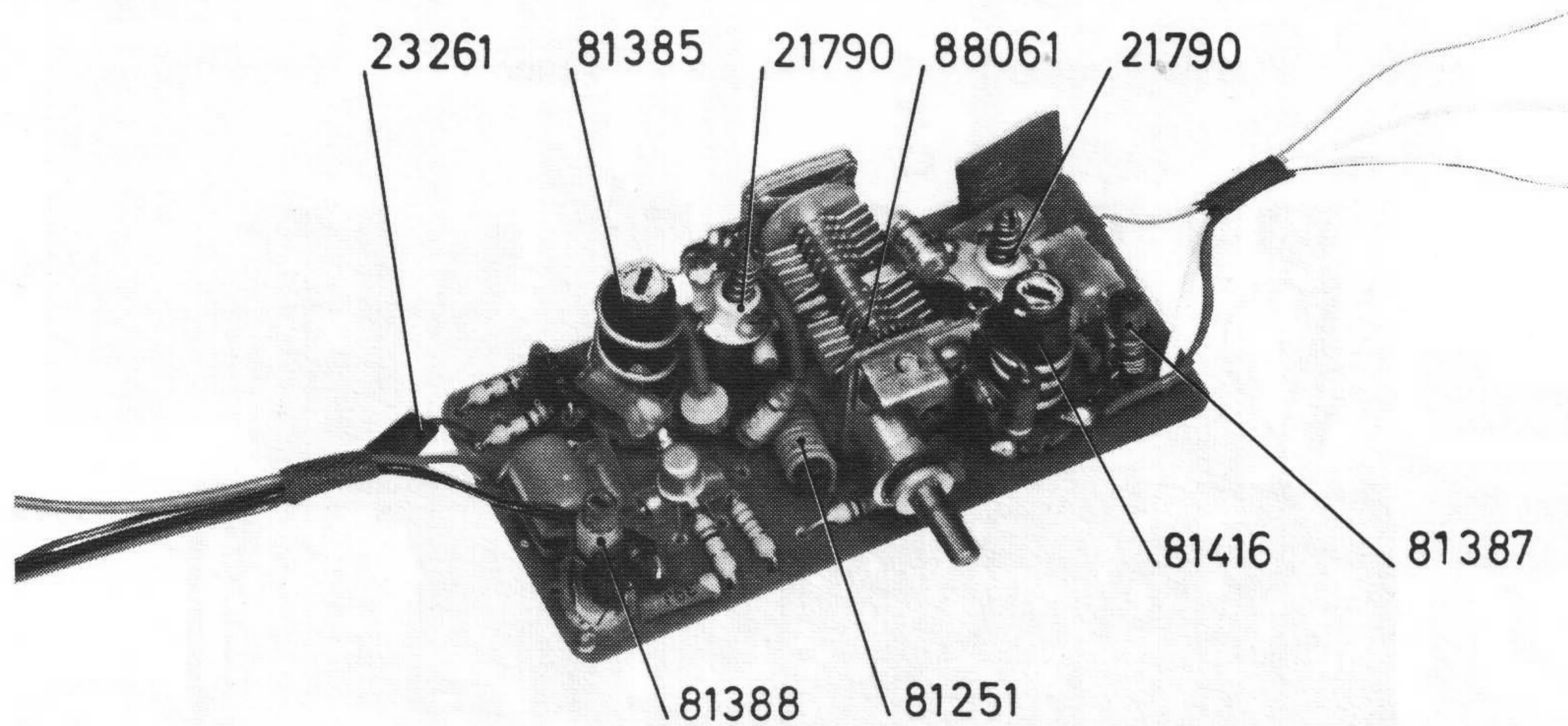

Fig.5

TRIMNINGSANVISNING INSTRUCTION FOR TUNING

GENERATOR MOD. 100 HZ FM 25 kHz SVING			MOTTAGARE (RECEIVER)	TRIMNING (TUNING)	KÄNSLIGHET FÖR 10 mV ÖVER MF-FÖRSTÄRKARENS LF-UTGÅNG	ANM. (REMARKS)
OMRÅDE (RANGE)	SIGNALINGÅNG (SIGNAL INPUT)	FREKV. (INDEX)	SKALVISARE (INDEX)		INTENSITIVITY FOR 10 mV OVER LF-OUTPUT OF IF- AMPLIFIER	
MF (IF)	BAS AF 125 LÅGIMPEDIV INGÅNG VIA KOND. (10nF) LOW IMPEDANCE INPUT THROUGH COND. (10nF)	10,7MHz 65 kHz SVING	87 MHz	SP1, SP2, SP3, SP4, SP5, SP6, SP 7 UPPREPAS (TO BE REPEATED)	CA 40µV	OSCILLOSKOP ANSLUTET TILL MF-FÖRSTÄRKARENS LF-UTGÅNG TRIMNING PÅ MAX. AMPLITUD VID BÄSTA LF-KURVFORM OSCILLOSCOPE, CONNECTED TO LF-OUTPUT OF IF-AMPLIFIER TUNING ON MAX. AMPLITUDE AT BEST FORM OF LF-CURVE
FM	FM-ANTENN 300 Ω SYMMETRISK	88 MHz 100 MHz 94 MHz	88 MHz 100 MHz 94 MHz	SP 8, SP 9 TR 1, TR 2 UPPREPAS (TO BE REPEATED)	CA 3µV	ATOMATIKEN KAN OM SÅ ÖNSKAS SÄTTAS UR FUNKTION GENOM KORTSLUTNING AV C 321 (EJ NÖDVÄND. FÖR TRIMNING) IF DESIRED THE AUTOMATIC CAN BE SET OUT OF OPERATION BY SHORT-CIRCUITING OF C 321 (NOT REQUESTED FOR TUNING)