

MC1250

SERVICE MANUAL

**MC² AUDIO Ltd.,
Units 6 & 7, Kingsgate,
Heathpark Industrial Estate,
HONITON,
Devon EX14 8YD
England**

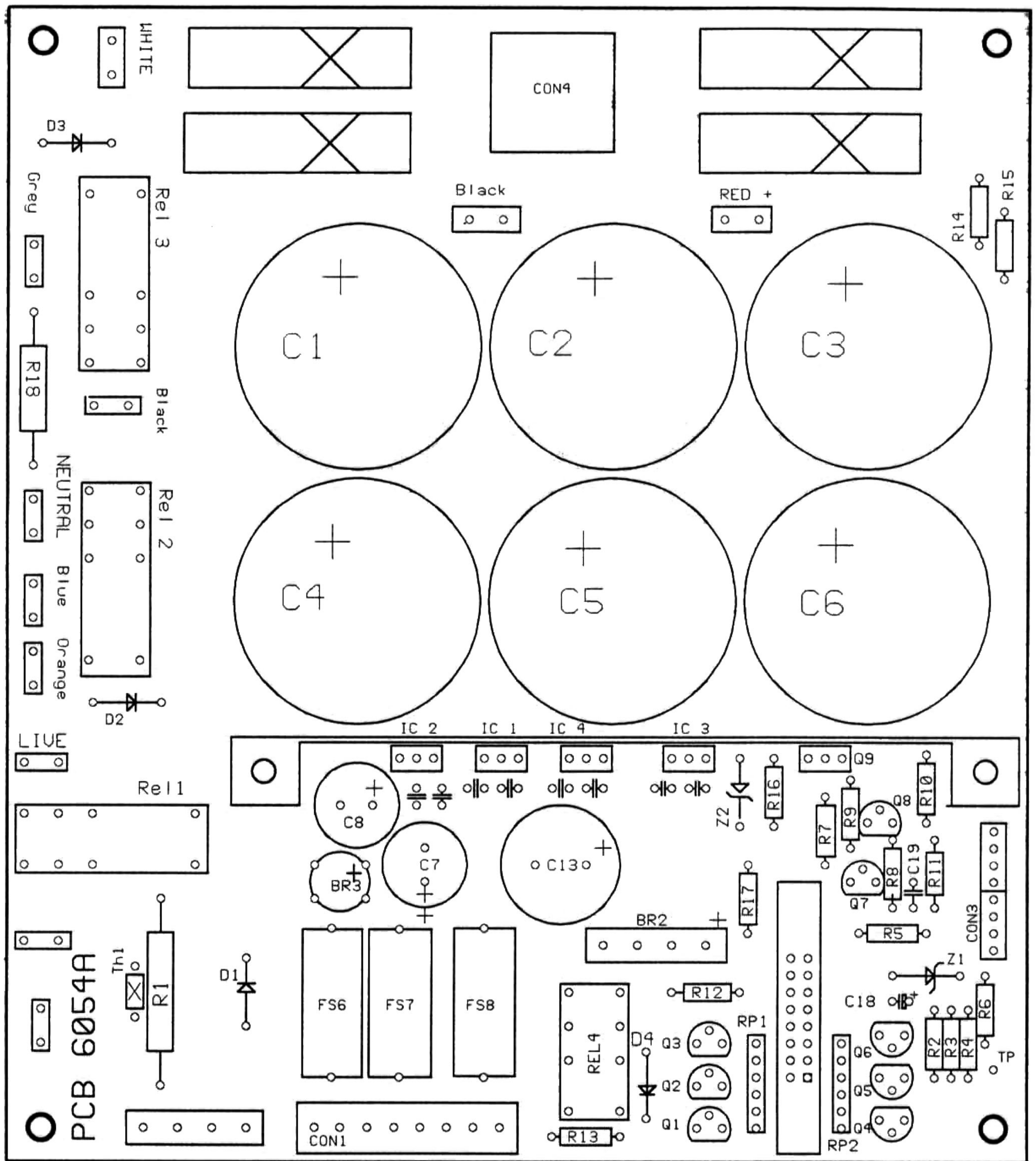

Scale = x 0.8

To remove/replace the power module in an MC1250 amplifier

A full set of electronic engineers tools will be required which should include:-

M4 nut driver with a retaining clip (or fill the end with a silicone putty such as 'Blu Tac')

To re-align the module the following test equipment will be required as an absolute minimum:-

Oscilloscope (20mHz minimum)

Digital Volt Meter

Audio Test Set with sine wave oscillator and millivolt meter

DC Current probe with a resolution of 10mA

2 x 4 ohm resistive loads, capable of dissipating 1250 Watts

To remove the module:-

1. Disconnect all connectors from the front of the module.
2. Using the M4 nut driver, remove the 3 nuts which hold down the module base plate to the chassis.
3. Lift out the module - this is best done by lifting the rear of the module clear of the rear chassis bar first, using a tilting action.
4. Lift the module forward and remove the output cable from the centre of the module.
5. Lift the module clear of the chassis.

Replace the new module by following the above steps in reverse order.

NOTE: You may find the above operations easier if you first remove the plastic finger guard from the rear panel.

To re-align the module - See drawing - MC1250 Top view 16/6/1997.

1. Attach the DC current clamp around the +VE (RED) power cable to the new module at the VCC buss bar on the capacitor bank as shown on the diagram.
2. Turn the Bias preset on the module DOWN (clockwise). **See note below.
3. Turn on the amplifier. Set the bias to 200mA.
4. Turn the level controls to both channels up to maximum. Insert a signal #(+3dBu at 1kHz) into each input, monitor the outputs of both channels on the oscilloscope and measure the output level of the new module. Do not attach the loads to the outputs at this stage.

5. Measure the output levels, they should be at +36dBu. Adjust the gain controls on the rear of the input PCB accordingly.
6. Attach the 4 ohm loads to both outputs. Ensure that the LINK switch on the front panel is OFF. Turn the input signal up until the outputs clip or the limit LEDs come on.
Adjust the limit controls on the rear of the input PCB so that the outputs limit just below the clipping point. This should be at +39dBu.
7. Reduce the output level to +36dBu. Allow the modules to heat up so that the fans are running fast. Switch off the input signal or mute both outputs and re-adjust the bias on the new module to about 280mA (anywhere between 250mA and 300mA is OK).

****NOTE:** If you do not have the equipment necessary to measure/adjust the bias level, then ensure that the **bias preset is left in its factory-set position.**

CAUTION

The heatsinks are live +115V and -115V off load. Use extreme caution when setting up amplifier.

Level/Limiter adjustment

The amplifier gain is set by a preset potentiometer for each channel - VR2 and VR22. These are located on the audio input circuit board PCB631, which is located on the rear panel. The limiter levels are set by VR3 and VR23 on the same PCB.

Adjustment Procedure

1. Input a signal 1kHz @ 0dBu into both inputs. This can be done without using a load.
2. Turn the level controls to maximum. Adjust VR2 (Ch. A) and VR22 (Ch. B) to give an output at the speaker connectors of +33dBu.
3. Couple a 4Ω resistive load capable of handling 1250 watts to each output. Monitor the outputs on an oscilloscope. Ensure that the link LED is **OFF**.
4. Turn the input up to +7 dBu and adjust VR3 (Ch. A) and VR23 (Ch. B) so that the limit LEDs turn on just below the clipping point. This should be at about 1200 watts (+39.2dBu) with both channels at maximum.

#NOTE: **TURBOSOUND** amps. have 4dB lower sensitivity, therefore the signal input (re-alignment 4) should be +7dBu for maximum output.

MC1250 Power supply 220/230/240 VAC.

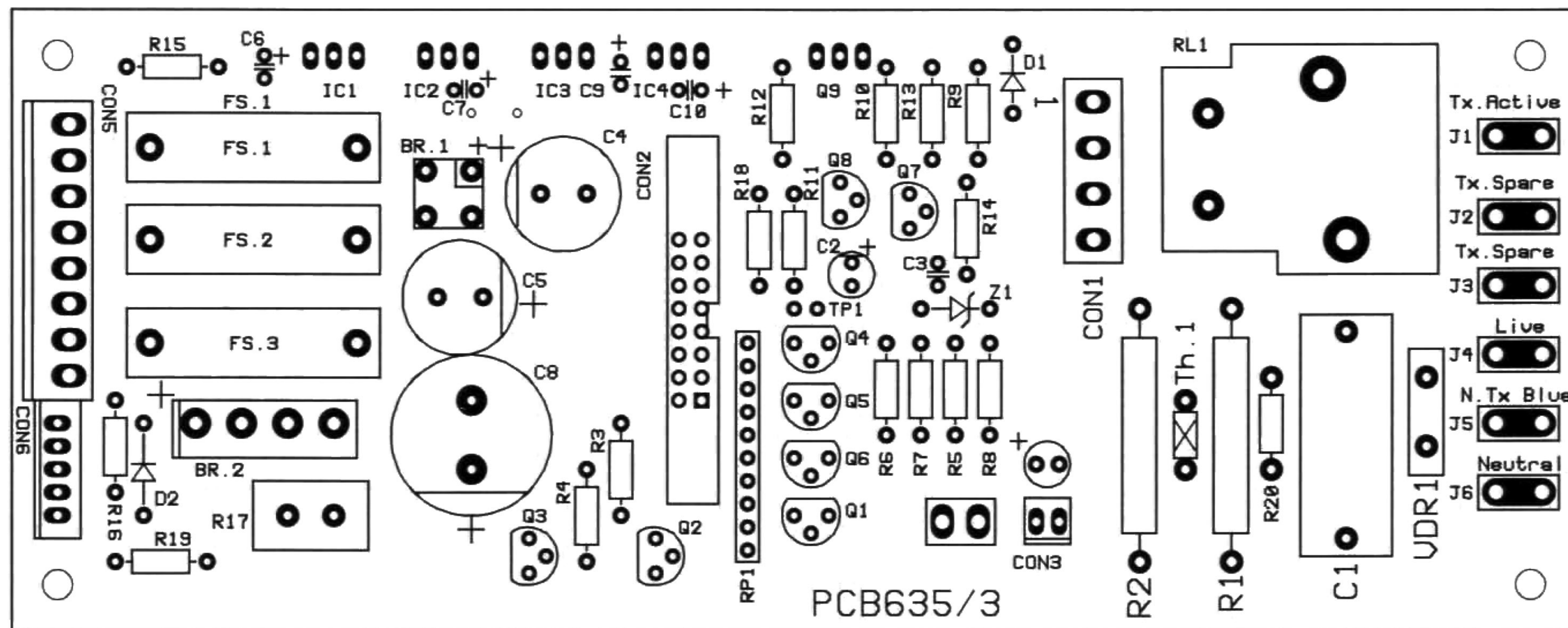

	240V.	230V.	220V.
Tx. Active J1	Brown	Yellow	Orange
Tx. Spare J2	Yellow	Brown	Yellow
Tx. Spare J3	Orange	Orange	Brown

- J4 Live
- J5 N. Tx Blue
- J6 Neutral

To change the mains voltage settings, change over the transformer leads as shown above.

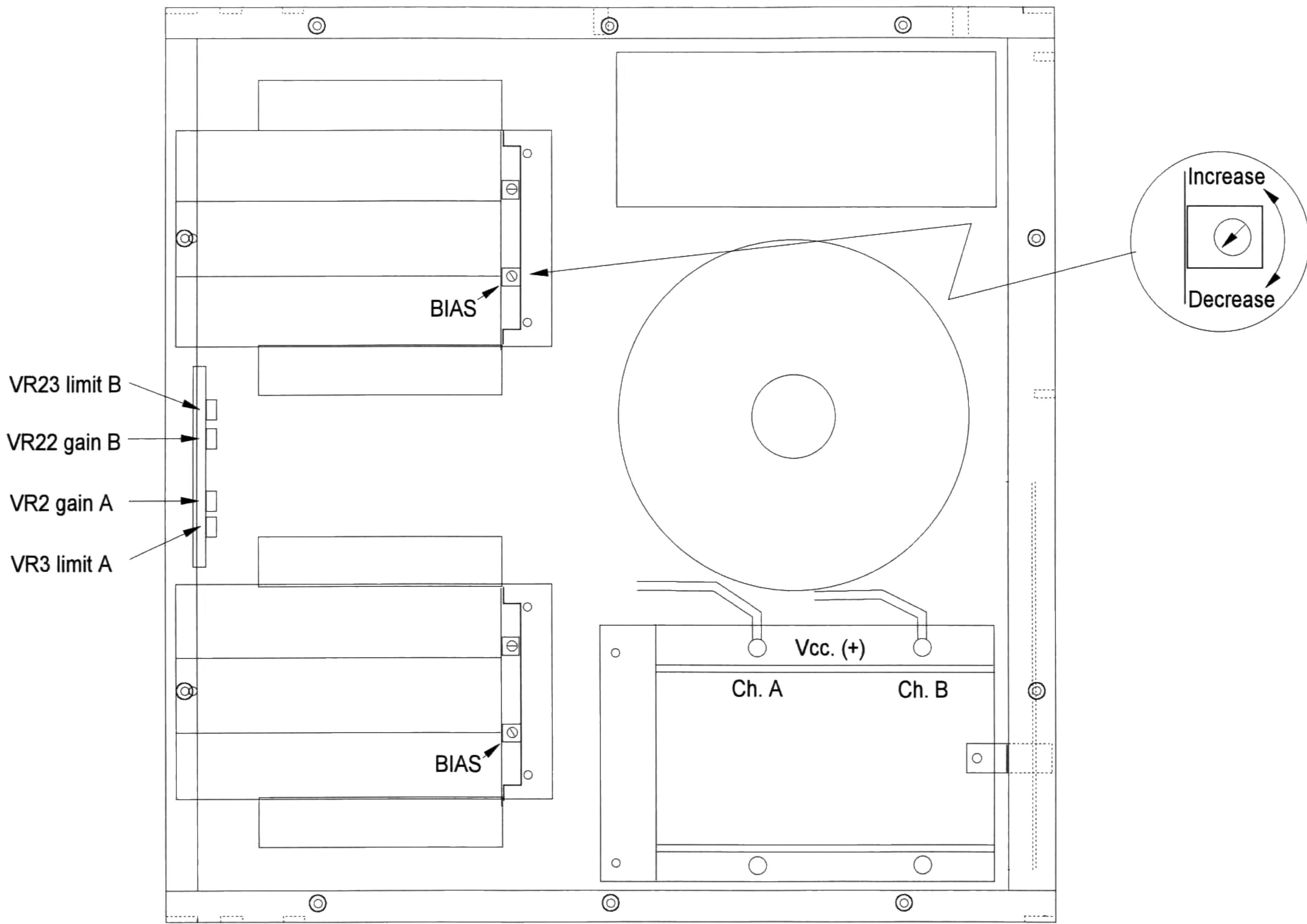

MC1250 CIRCUIT DIAGRAMS

<u>TITLE</u>	<u>DESCRIPTION</u>
LAY1250	CIRCUIT LAYOUT
PCB631/2	INPUT PCB
PCB632/2	OUTPUT DRIVE STAGE
PCB633/2	OUTPUT POWER PCB
PCB634/2	OUTPUT POWER PCB
	}POWER }MODULE }
PCB635/2	POWER SUPPLY
PCB636	OUTPUT CONNECTOR AND RELAY PCB
PCB639	MAIN RECTIFIER ASSEMBLY
* PCB6034/1250	CONTROL PCB
# PCB604/2	DISPLAY PCB
* PCB6034	is the same as the one used on the MC650 and MC450 WITH THE EXCEPTION OF:-

Software

R14a (3K3) fitted across R14 to accommodate 24V -
(12V on MC650/450)

PCB604/2 identical to the MC650/450

NOTE: Power transistor types 2SC3281 and 2SA1302 (Q2 - Q10 on PCBs 633/2 and 634/2) are factory selected 240 volt versions.

Normal 200 volt versions MUST NOT BE USED.

This applies to the MC1250 only.

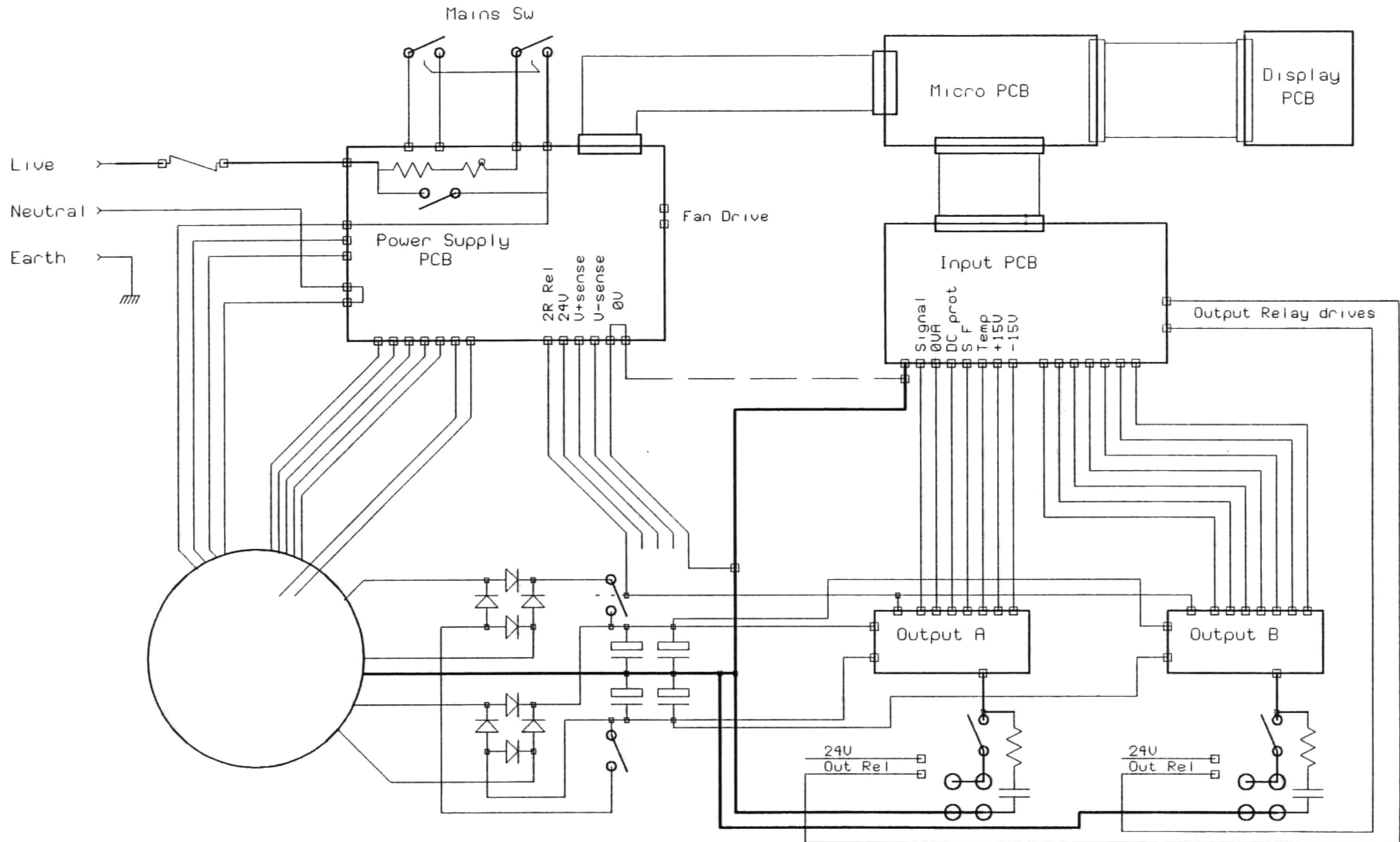

Date	28 MARCH 1997	
Dwng.No.	LAY1250	Sheet 1 of 1

Channel A only shown for Channel B component numbers add 20 (i.e. R1 = R21)

IC1 = NE5532
 IC2 = PM7524
 IC3 = TL072

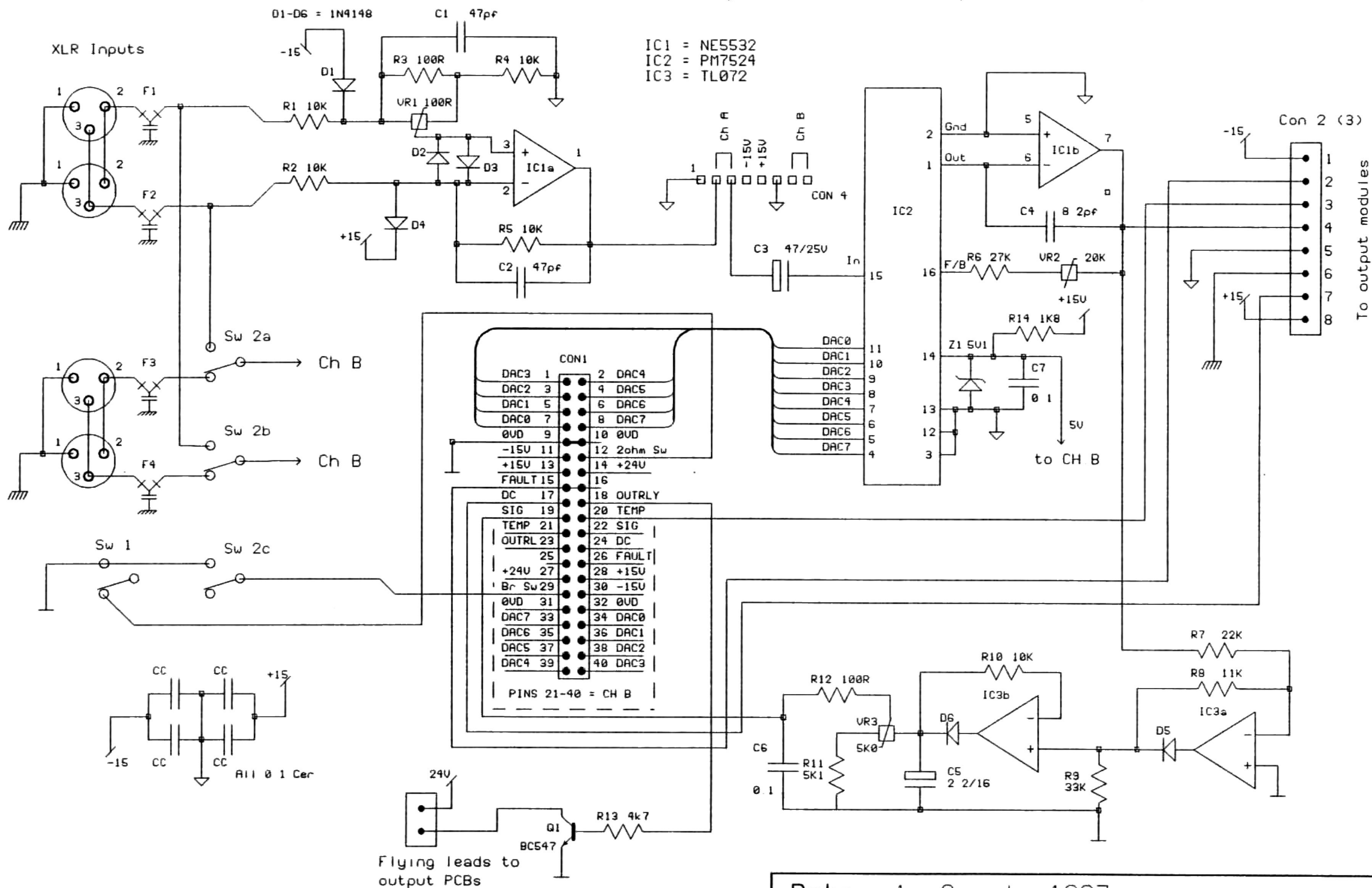

Date 1 April 1997

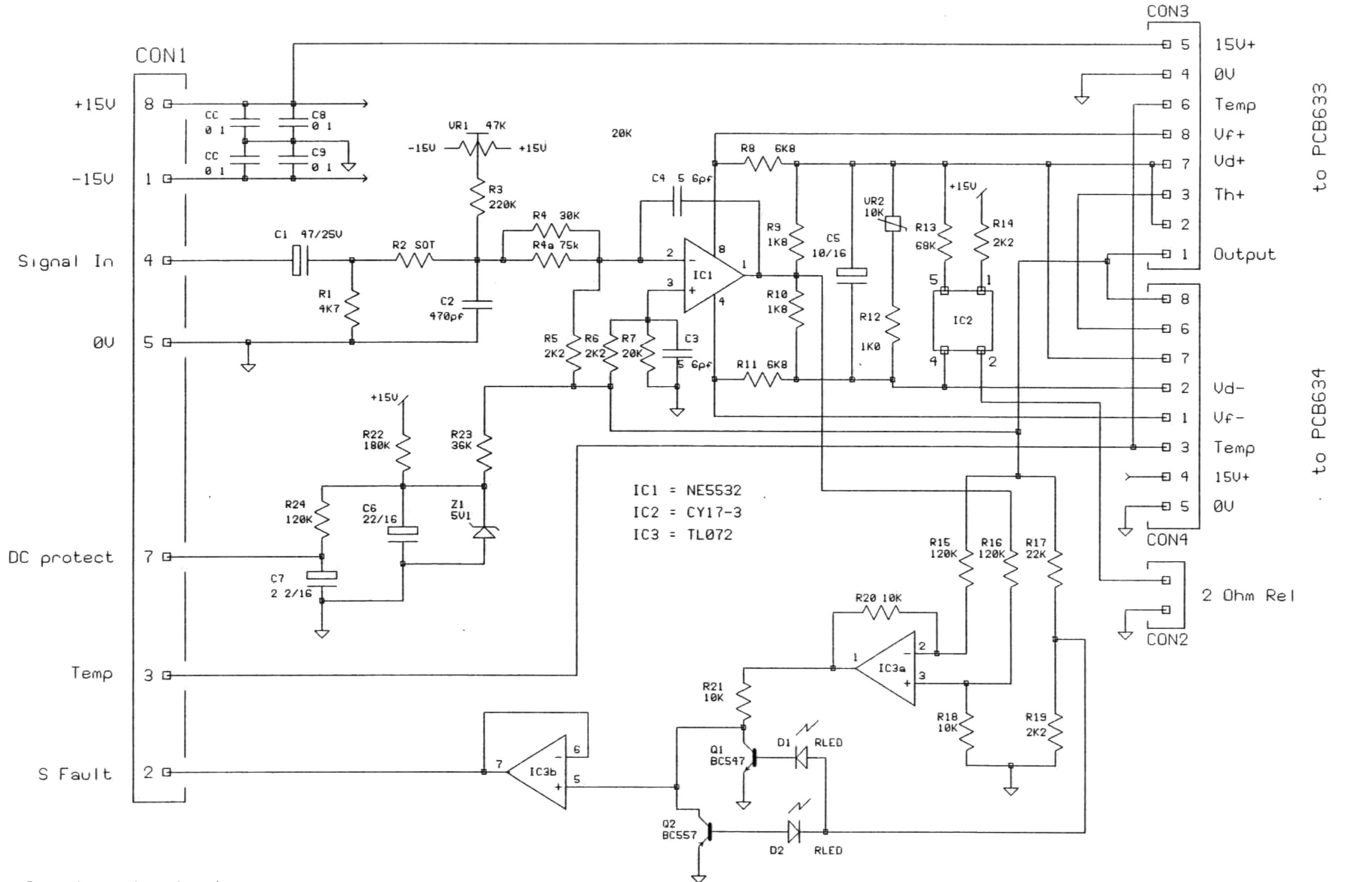

to PCB633

to PCB634



Rev: 1	Date: 21.06.1997	Eng: M N SILLETT
Project: PCB634/2		
Company: M C AUDIO LTD		
Address: UNIT 6 KINGSGATE INDUSTRIAL ESTATE		
City: HONITON		
Country: DEVON		
Initial date: 21.06.1997	Page: 1	of: 1



Rev: 1	Date: 21.06.1997	Eng: M N SILLETT
Project: PCB633/2		
Company: M C AUDIO LTD		
Address: UNIT 6 KINGSGATE INDUSTRIAL ESTATE		
City: HONITON		
Country: DEVON		
Initial date: 21.06.1997	Page: 1	of: 1



BUSS BAR BRACKET ASSEMBLY

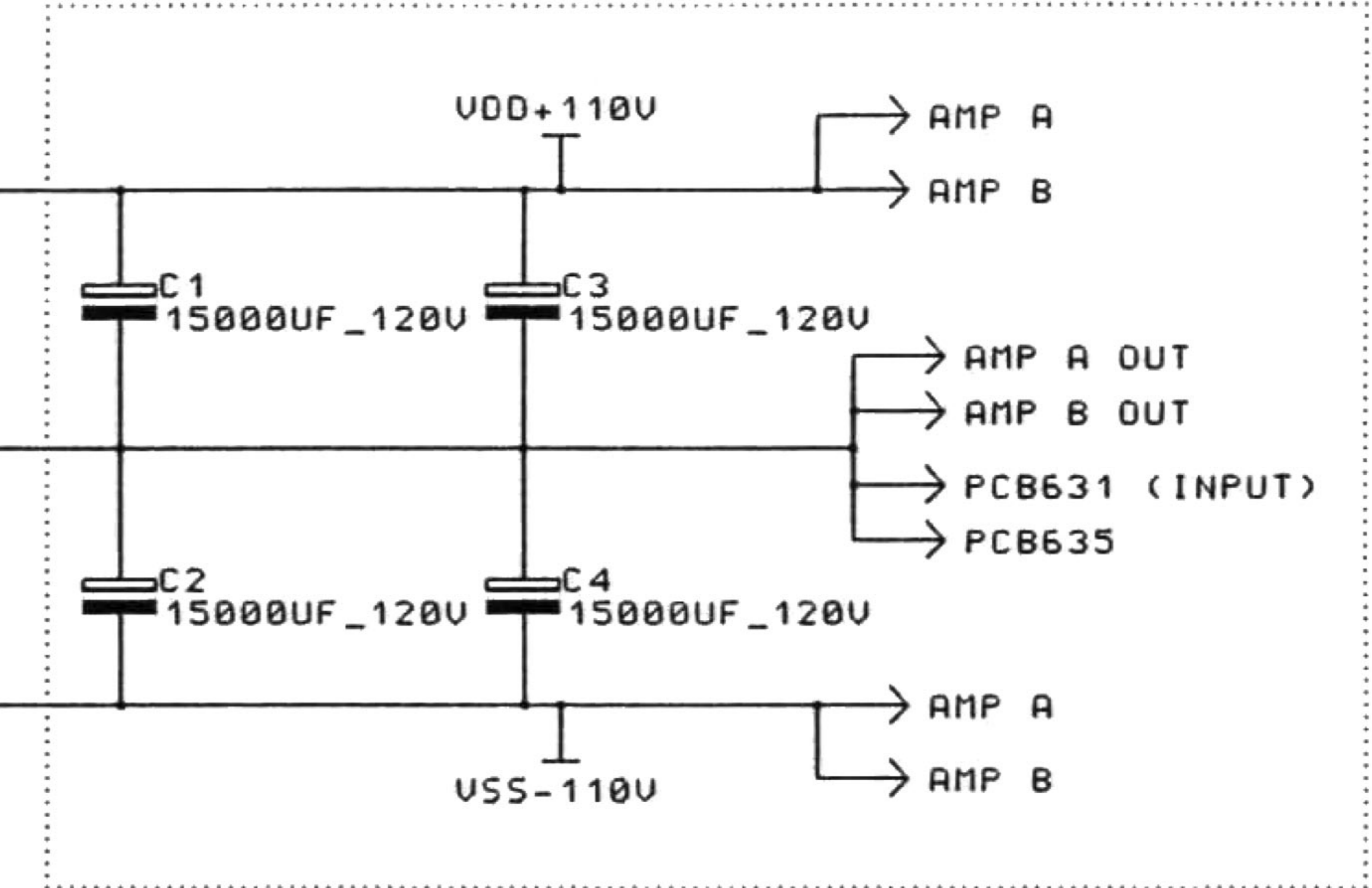

ALL CONNECTIONS TO BUSS BARS VIA SCREW/RING TERMINALS

Rev: 1	Date: 21.06.1997	Eng: M N SILLETT
Project: PCB639/1		
Company: M C AUDIO LTD		
Address: UNIT 6 KINGSGATE INDUSTRIAL ESTATE		
City: HONITON		
Country: DEVON		
Initial date: 21.06.1997	Page: 1	of: 1



Rev 1	Date 21 06 1997	Eng M N SILLETT
Project PC8639/2		
Company M C AUDIO LTD		
Address UNIT 6 KINGSGATE INDUSTRIAL ESTATE		
City HONITON		
Country DEVON		
Initial date 21 06 1997	Page 1	of 1

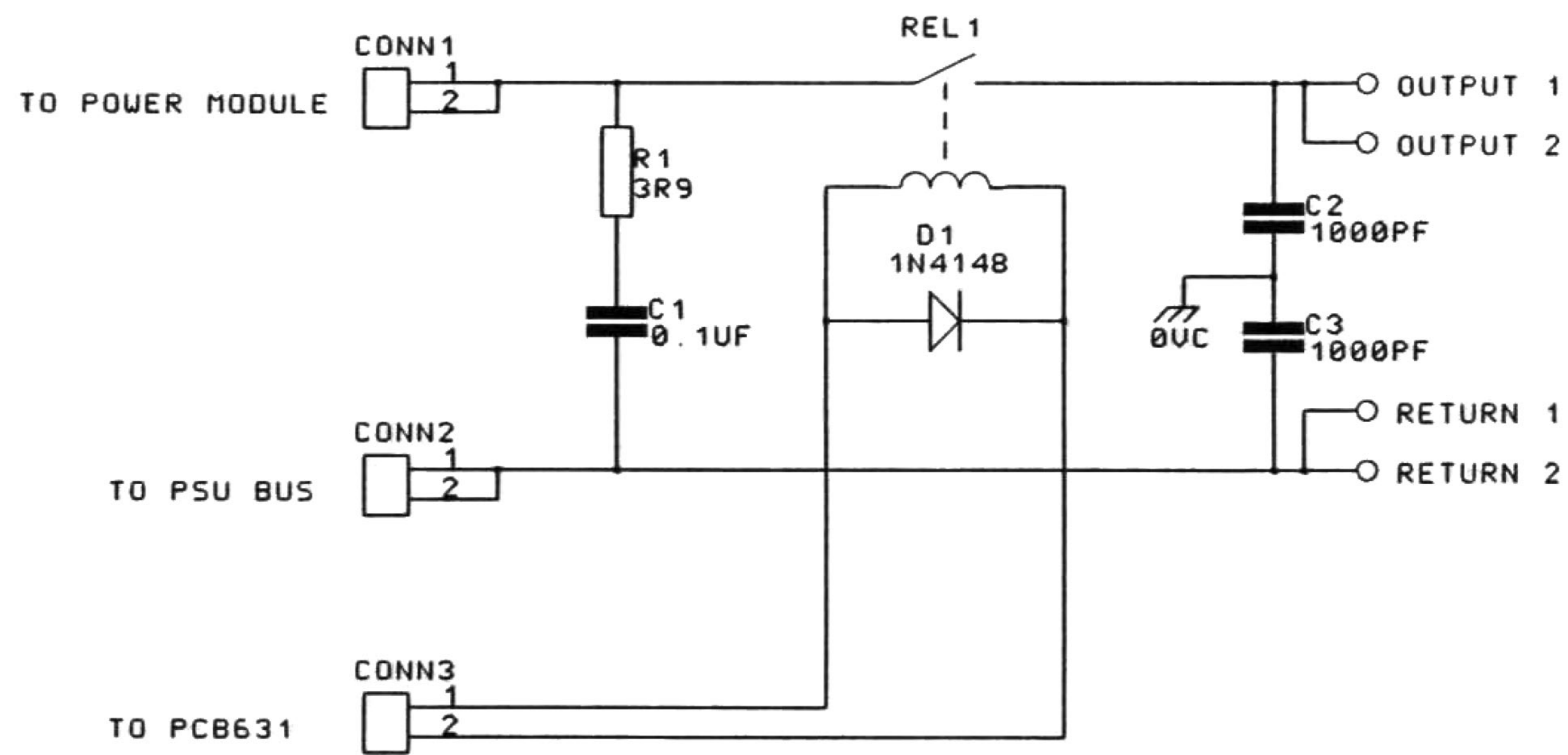

Rev: 1	Date: 21.06.1997	Eng: M N SILLETT
Project: PCB636A & PCB636B		
Company: M C AUDIO LTD		
Address: UNIT 6 KINGSGATE INDUSTRIAL ESTATE		
City: HONITON		
Country: DEVON		
Initial date: 21.06.1997	Page: 1	of: 1