

OWNERS and SERVICE MANUAL for

MAESTRO® ECHOPLEX



Echoplex EP-4

contents

Introduction	1	Maestro Sireko ES-1	6
Maestro Echoplex EP-3	1	Features	6
Maestro Echoplex EP-4	1	Power Source	6
Maestro Sireko ES-1	1	Record Level Adjustment	7
Maestro Echoplex EP-3	2	Echo Volume Control	7
Features	2	Echo Sustain	7
Use of "Sound on Sound"	2	Echo On/Off Control	7
Power Source	2	Echo Delay Control	8
Record Level Adjustment	2	Echo Chamber Effects for Vocalists	8
Echo Volume Control	3	Care of the Sireko	8
Echo Sustain Control	3	Tape Cartridges	8
Echo On/Off Control	3	Service Information	9
Echo Delay Control	3		
Playback Feature	3		
Echo Chamber Effects for Vocalists	3		
Care of the Echoplex	3		
Tape Cartridges	4		
Maestro Echoplex EP-4	4		
Features	4		
Use of the Echoplex	4		
Power Source	4		
Record Level Adjustment	5		
Echo Volume Control	5		
Echo Sustain Control	5		
Echo On/Off Control	5		
Echo Delay Control	5		
Echo Tone Control	5		
Playback Feature	6		
Echo Chamber Effects for Vocalists	6		
Care of the Echoplex	6		
Tape Cartridges	6		

THESE DRAWINGS AND SPECIFICATIONS ARE THE PROPERTY OF MOOG MUSIC INC. AND SHALL NOT BE REPRODUCED OR COPIED IN WHOLE OR IN PART AS THE BASIS FOR MANUFACTURE OR SALE OF THE ITEMS.

Introduction

The Maestro Echoplex is the pioneer of on stage echo units. Today it remains the most popular, versatile unit of its kind and operates equally well with instrument or voice. It is a product of careful design engineering to enhance the musicians artistry and is endorsed by leading musicians.

The first section of the manual presents the general features of Echoplex EP-3, EP-4 and Sireko ES-1 followed by specifications, operation, general information and care and service of each model. Further information is supplied by the head alignment instructions, schematic diagrams for specific serial numbers, various views of Echoplex models and an overall selected replacement parts list.

Maestro Echoplex EP-3

The Maestro Echoplex EP-3 has the ability to turn off the erase and record heads. By turning off the erase head you can achieve "Sound on Sound", an exclusive with Maestro Echoplex. "Sound on Sound" means you can play along with and add effects to what you previously played.

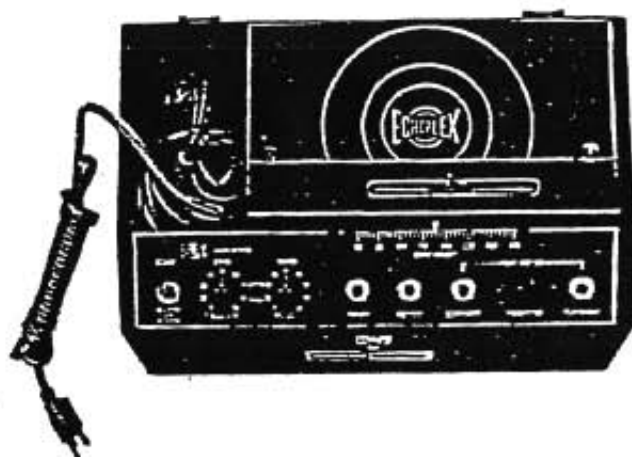

Maestro Echoplex EP-4

The Maestro Echoplex EP-4 controls over the effects have been improved including echo tone controls, a recording level knob and a recording level LED indicator. Two inputs now allow you to play into your mixer. More rugged construction means the Maestro Echoplex EP-4 is even more reliable than ever.



Maestro Sireko ES-1

The Maestro Sireko ES-1 by Echoplex offers all of the fine features of the Echoplex with the exception of "Sound on Sound". The echo delay and echo repeat speed controls afford countless possibilities for the value conscious musician.

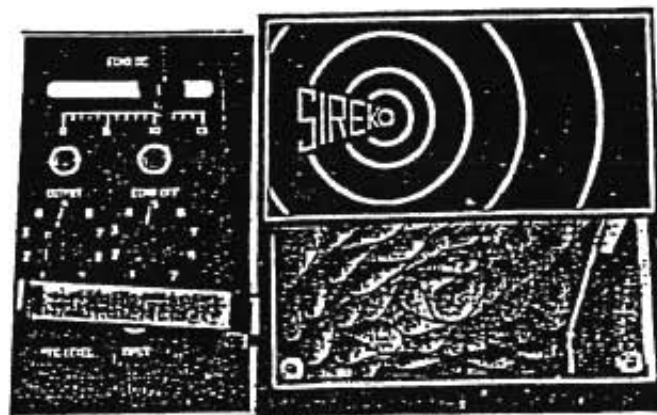

Maestro Echoplex EP-3

FEATURES

- Echo On/Off can be controlled with foot switch.
- Playback feature — record and playback in accompaniment.
- Special Effects — created by increasing the echo feedback with the sustain control.
- Exclusive Echoplex replaceable two minute tape cartridge included.
- Foot switch, cables and carrying case included.
- Wow and flutter less than 0.3%.
- 15 pounds total weight.
- 13 inches wide, 18-1/4 inches deep, 8-1/8 inches high.
- Operates on 110 volt, 60 cycle AC current.

USE OF "SOUND ON SOUND"

- Make the first recording with the ECHO/SOUND ON SOUND switch in ECHO position.
- Place the switch in SOUND ON SOUND position. The original recording will be played back and recorded at the same time. You may now add another recording while listening. Repeat this procedure and record each time to add as many recordings as you wish.
- If you wish to just listen and practice before recording, press playback foot switch inserted into FOOT SWITCH PLAYBACK jack. You will not be recording or erasing during this time.
- ECHO/SUSTAIN control is not operative during the "Sound on Sound" recordings.

POWER SOURCE

CAUTION

The Echoplex may be damaged if connected to an incorrect power source.

- Connect to 105/125 volt, 60 cycle power source.
- Turn on ECHO SUSTAIN control and allow five minute warmup period to allow for cold condensation, that may exist, to disappear.
- If motor fails to start, slap sides of cabinet. This will realign bearings if unit has been roughly handled during shipment.
- Connect OUTPUT jack into INPUT jack of amplifier.
- Connect instrument into INPUT jack of Echoplex.

RECORD LEVEL ADJUSTMENT

The Echoplex contains new circuitry to reduce "hiss" and distortion. For best results, adjust the record level as follows:

- After connecting the Echoplex to your equipment, turn the ECHO VOLUME control to "1" and listen to the tone.
- Turn ECHO VOLUME control to "9" and repeat the same tone.
- If the volume of the tone is not equal with the ECHO VOLUME at "1" and "9", insert a small screwdriver into the hole marked RECORD LEVEL and slowly adjust until the tone is equal with the ECHO VOLUME at "1" and "9".

NOTE

Do not turn RECORD LEVEL clockwise too far or "hiss" will increase.

- When RECORD LEVEL adjustment is made properly, the Echoplex will perform properly with no distortion on a minimum of "hiss".

ECHO VOLUME CONTROL

For balancing between instrument and echo sound.

- Turn ECHO REPEATS control to "1".
- Turn VOLUME (mixer) Instrument/Echo control to left.
- Pluck one string and you will hear straight through sound.
- Keep plucking string and slowly turn VOLUME control clockwise and you will hear an echo sound introduced into the guitar's original sound.
- Slowly continue to turn VOLUME control clockwise and you will hear an increase in echo volume and a decrease in straight through sound and finally you will hear only the recorded, or echo sound.

ECHO SUSTAIN CONTROL

To increase number of echoes following the sound through.

- To select desired number of echo repeats, mute the guitar strings . . . staccato . . . so as to make a short sound.
- Slowly turn ECHO SUSTAIN control clockwise and you will hear the number of echo repeats increasing to the point where they take over and "run away" or feed back.

NOTE

This EXTRA POWER is there only to compensate when tape heads become worn or cleaning has been neglected.

- In your setting of the ECHO SUSTAIN control, when you come to the "run away", back off, and turn control counterclockwise until the "run away" is corrected.

ECHO ON/OFF CONTROL

- Provided to turn echo on/off as desired by the foot switch.
- Connect foot switch into FOOT SWITCH ECHO/OFF jack.
- Depress foot switch for on/off action.

ECHO DELAY CONTROL

- Longest echo "delay" achieved when pointer is at the highest number. Delay shortens as control pointer is moved towards "0".

PLAYBACK FEATURE

Only the Echoplex enables you to record and playback recorded material in accompaniment.

- Connect foot switch into PLAYBACK jack.
- Alternate switch button on pedal and you can rotate between recording and playback instantaneously.
- When RECORDING light glows, you are in "recording" position.
- Tape will play over and over until you switch foot pedal control.

ECHO CHAMBER EFFECTS FOR VOCALISTS

- Connect output of Echoplex into microphone amplifier.
- Connect microphone into Echoplex INPUT jack.
- Operate controls as previously explained for many unusual effects that can be secured as you master the Echoplex technique.

CARE OF THE ECHOPLEX

As is true on all tape recorders, it is necessary to clean tape heads, capstan and roller regularly for best results and achieve maximum echo/playback.

Loss of brilliance, echo repeats and playback depends upon the care of your Echoplex.

- Remove cover.
- Remove tape from between heads, guides and rollers.
- Use alcohol and cotton cue stick to swab parts.

CAUTION

Take care to avoid getting fluid on tape.

- Allow parts to dry a few seconds, then follow diagram on inside top cover to replace tape.
- Allow tape to run a few minutes to be sure that tape is positioned correctly before replacing cover.

TAPE CARTRIDGES

Tape cartridges are available at your dealer. Keep a spare with your Echoplex. Cartridges are easily installed if the replacement procedure contained in the spare tape cartridge carton is followed.

Maestro Echoplex EP-4

FEATURES

- Echo On/Off can be controlled with foot switch.
- Playback feature — record and playback in accompaniment.
- Special Effects — created by increasing the echo feedback with the sustain control.
- Exclusive Echoplex replaceable ~~1/2~~ minute tape cartridge included.
- Foot switch, cables and carrying case included.

- Wow and flutter less than 0.15%.
- 15 pounds total weight.
- 13 inches wide, 18-1/4 inches deep, 8-1/8 inches high.
- Operates on 110 volt, 60 cycle AC current.
- LED's to indicate RECORDING LEVEL.

USE OF THE ECHOPLEX

While retaining the time proven dependable mechanical features, additional electronics have been incorporated into this Echoplex to increase its versatility.

POWER SOURCE

CAUTION

The Echoplex may be damaged if connected to an incorrect power source.

- Connect to 105/125 volt, 60 cycle power source.
- Turn on RECORDING VOLUME control and allow five minute warmup period for cold condensation, that may exist, to disappear.
- If motor fails to start, slap sides of cabinet. This will realign bearings if unit has been roughly handled during shipment.
- Connect OUTPUT jack into INPUT jack of amplifier.
- Connect instrument into INPUT jack of Echoplex.

NOTE

OUTPUT jacks are located in the compartment area. The forward jack is for musical instrument amplifiers. The jack is a high level, emitter follower output, for use with high or low impedance PA mixer panels.

RECORD LEVEL ADJUSTMENT

The Echoplex contains new circuitry to reduce "hiss" and distortion. For best results, adjust the record level as follows:

- A RECORDING LEVEL indicator is provided to monitor the sound as it is being recorded on tape.
- During the performance, advance the RECORDING VOLUME control so that as the louder peaks are played, the green indicator will be active.
- If yellow is indicated, then too little volume is being recorded on tape. Turn up amplifier volume to the point where tape "hiss" is objectionable.
- Echoplex is better than 50dB, and if recordings are made at the proper level, tape "hiss" will not be objectionable.
- Indication on the red area is too high, and may cause distortion.

ECHO VOLUME CONTROL

For balancing between instrument and echo sound.

- Turn ECHO/REPEATS control to "1".
- Turn VOLUME (mixer) Instrument/Echo control to full counterclockwise.
- Pluck one string and you will hear straight through sound.
- Keep plucking string and slowly turn VOLUME control clockwise and you will hear an echo sound introduced into the guitar original sound.
- Slowly continue to turn VOLUME control clockwise and you will hear an increase in echo volume and a decrease in straight through sound and finally you will hear only the recorded, or echo sound.

ECHO SUSTAIN CONTROL

To increase number of echoes following the sound through.

- To select desired number of echo repeats, mute the guitar strings . . . staccato . . . so as to make a short sound.
- Slowly turn ECHO SUSTAIN control clockwise and you will hear the number of echo repeats increasing to the point where they take over and "run away" or feed back.

NOTE

This EXTRA POWER is there only to compensate when tape heads become worn or cleaning has been neglected.

- In your setting of the ECHO SUSTAIN control, when you come to the "run away", back off, and turn control counterclockwise until the "run away" is corrected.

ECHO ON/OFF CONTROL

- Provided to turn echo on/off as desired by the foot switch.
- Connect foot switch into ECHO/OFF jack.
- Depress foot switch for on/off action.

ECHO DELAY CONTROL

- Longest echo delay achieved when pointer is at LONG. Delay shortens as control is moved towards SHORT.

ECHO TONE CONTROL

Separate BASS and TREBLE tone controls to create special tonal effects with the echo sound.

- Center position of both controls is normal tone.
- Turning either control will either add or subtract in that tonal range and affects only the playback of the echo, and does not affect the sound as it is being recorded.

PLAYBACK FEATURE

Only the Echoplex enables you to record and playback recorded material in accompaniment.

- Connect foot switch into PLAYBACK jack.
- Alternate switch button on pedal and you can rotate between recording and playback instantaneously.
- When RECORDING light glows, you are in "recording" position.
- Tape will play over and over until you switch foot pedal control.

ECHO CHAMBER EFFECTS FOR VOCALISTS

- Connect output of Echoplex into microphone amplifier.
- Connect microphone into Echoplex INPUT jack.
- Operate controls as previously explained for many unusual effects that can be secured as you master the Echoplex technique.

CARE OF THE ECHOPLEX

As is true on all tape recorders, it is necessary to clean tape heads, capstan and roller regularly for best results and achieve maximum echo/playback. Loss of brilliance, echo repeats and playback depends upon the care of your Echoplex.

- Remove cover.
- Remove tape from between heads, guides and rollers.
- Use alcohol and cotton swab stick to swab parts.

CAUTION

Take care to avoid getting fluid on tape.

- Allow parts to dry a few seconds, then follow diagram on inside top cover to replace tape.
- Allow tape to run a few minutes to be sure that tape is positioned correctly before replacing cover.

TAPE CARTRIDGES

Tape cartridges are available at your dealer. Keep a spare with your Echoplex. Cartridges are easily installed if the replacement procedure contained in the spare tape cartridge carton is followed.

Maestro Sireko ES-1

FEATURES

- Echo On/Off can be controlled with foot switch.
- Special Effects created by increasing the echo feedback with the sustain control.
- Foot switch, cables and carrying case included.
- Wow and flutter less than .3%.
- 14-1/2 inches wide, 7-1/2 inches deep, 6-3/4 inches high.
- Operates on 110 volt, 60 cycle AC current.

POWER SOURCE

CAUTION

The Sireko may be damaged if connected to an incorrect power source.

- Connect to 105/125 volt, 60 cycle power source.

- Turn on ECHO SUSTAIN control and allow five minute warmup period to allow for cold condensation, that may exist, to disappear.
- If motor fails to start, slap sides of cabinet. This will realign bearings if unit has been roughly handled during shipment.
- Connect OUTPUT jack into INPUT jack of amplifier.
- Connect instrument into INPUT jack of Sireko.

RECORD LEVEL ADJUSTMENT

- Remove round plug marked RECORD LEVEL and turn slotted screw inside to match output of your guitar.

NOTE

This adjustment is very necessary. If the volume setting is too low a weak recording will occur, resulting in a poor signal-to-noise ratio. This low recording level would force you to turn up the amplifier volume level to a level that would cause tape "hiss". However, a high output guitar must be compensated for because it may cause an overloaded and distorted recording.

Adjustment procedures are as follows:

- Turn ECHO SUSTAIN control to "1".
- Turn ECHO VOLUME control clockwise. In this position you will hear only what is recorded.
- Strum strings of guitar as you normally play.
- If distortion occurs, slowly turn RECORD LEVEL adjustment screw counterclockwise until distortion disappears.
- If echo is weak, slowly turn RECORD LEVEL adjustment screw clockwise until guitar tones are strong and without distortion.
- One adjustment properly made should suffice as long as the same instrument is used.

ECHO VOLUME CONTROL

For balancing between instrument and echo sound.

- Turn ECHO/REPEATS control to "1".
- Turn VOLUME (mixer) Instrument/Echo control to full counterclockwise.
- Pluck one string and you will hear straight through sound.
- Keep plucking string and slowly turn VOLUME control clockwise and you will hear an echo sound introduced into the guitar original sound.
- Slowly continue to turn VOLUME control clockwise and you will hear an increase in echo volume and a decrease in straight through sound and finally, you will hear only the recorded, or echo sound.

ECHO SUSTAIN

To increase number of echoes following the sound through.

- To select desired number of echo repeats, mute the guitar strings . . . staccato . . . so as to make a short sound.
- Slowly turn ECHO SUSTAIN control clockwise and you will hear the number of echo repeats increasing to the point where they take over and "run away" or feed back.

NOTE

This EXTRA POWER is there only to compensate when tape heads become worn or cleaning has been neglected.

- In your setting of the ECHO SUSTAIN control, when you come to the "run away", back off and turn control counterclockwise until the "run away" is corrected.

ECHO ON/OFF CONTROL

- Provided to turn echo on/off, as desired, by the foot switch.

- Connect foot switch into FOOT SWITCH ECHO ON/OFF jack.

- Depress foot switch for on/off action.

ECHO DELAY CONTROL

- Longest echo delay achieved when pointer is at LONG. Delay shortens as control is moved towards SHORT.

ECHO CHAMBER EFFECTS FOR VOCALISTS

- Connect output of Sireko into microphone amplifier.
- Connect microphone into Sireko jack.
- Operate controls as previously explained for many unusual effects that can be secured as you master the Sireko technique. Reset RECORD LEVEL higher for a microphone.

CARE OF THE SIREKO

As is true on all tape recorders, it is necessary to clean tape heads, capstan and rollers regularly for best results and achieve maximum echo/playback.

Loss of brilliance, echo repeats and playback depends upon the care of your Sireko.

- Remove cover.
- Remove tape from between heads, guides and rollers.
- Use alcohol and cotton cue stick to swab parts.

CAUTION

Take care to avoid getting fluid on tape.

- Allow parts to dry a few seconds, then follow diagram on inside top cover to replace tape.
- Allow tape to run a few minutes to be sure that tape is positioned correctly before replacing cover.

TAPE CARTRIDGES

Tape cartridges are available at your dealer. Keep a spare with your Sireko. Cartridges are easily installed if the replacement procedure contained in the spare tape cartridge carton is followed.

Service Information

CONTENTS

Equipment Required	10
Control Setting	10
Bridge Alignment.....	10
Head Alignment	10
Playback Head	11
Sound on Sound Head Alignment	11
Selected Replacement Parts List	36

LIST OF ILLUSTRATIONS

Functional Block Diagram of Echoplex and Groupmaster Unit	10
Groupmaster EM-1, Front and Top View ...	12
Groupmaster EM-1, Inside Component Views	13
Groupmaster EM-1 Schematic Diagram	14
Echoplex EP-1 Model No. 5000 Schematic Diagram	15
Echoplex EP-1 and EP-2, Inside Bottom Component View	16
Echoplex EP-2 Schematic Diagram Serial No. 1549 to 2749	17
Echoplex EP-2 Schematic Diagram Serial No. 2750 to 5499	18
Echoplex EP-2 Schematic Diagram Serial No. 5500 to 5938	19
Echoplex EP-1 and EP-2, Top View	20
Echoplex EP-1 and EP-2, Inside Top Component View	21
Echoplex EP-3, Inside View	22

Echoplex EP-2 Schematic Diagram Serial No. 5939 to 9067	23
Echoplex EP-3, Top and Inside Views	24
Echoplex EP-3 Schematic Diagram Serial No. 9068 to 9450	25
Echoplex EP-3 Schematic Diagram Serial No. 9451 to 12960	26
Echoplex EP-3 Schematic Diagram Serial No. 12961 to 28591	27
Echoplex Compressor Board Schematic Diagram	28
Echoplex Compressor Board	29
Echoplex EP-4, Top and Inside Views	30
Echoplex EP-4 Schematic Diagram	31
Sireko SE-1 Schematic Diagram Circuit Board Hookup	32
Sireko SE-1, Top View	33
Sireko SE-1, Inside Views	34
Sireko SE-1 Schematic Diagram	35

THESE DRAWINGS AND SPECIFICATIONS ARE THE PROPERTY OF MOOG MUSIC INC. AND SHALL NOT BE REPRODUCED OR COPIED IN WHOLE OR IN PART AS THE BASIS FOR MANUFACTURE OR SALE OF THE ITEMS.

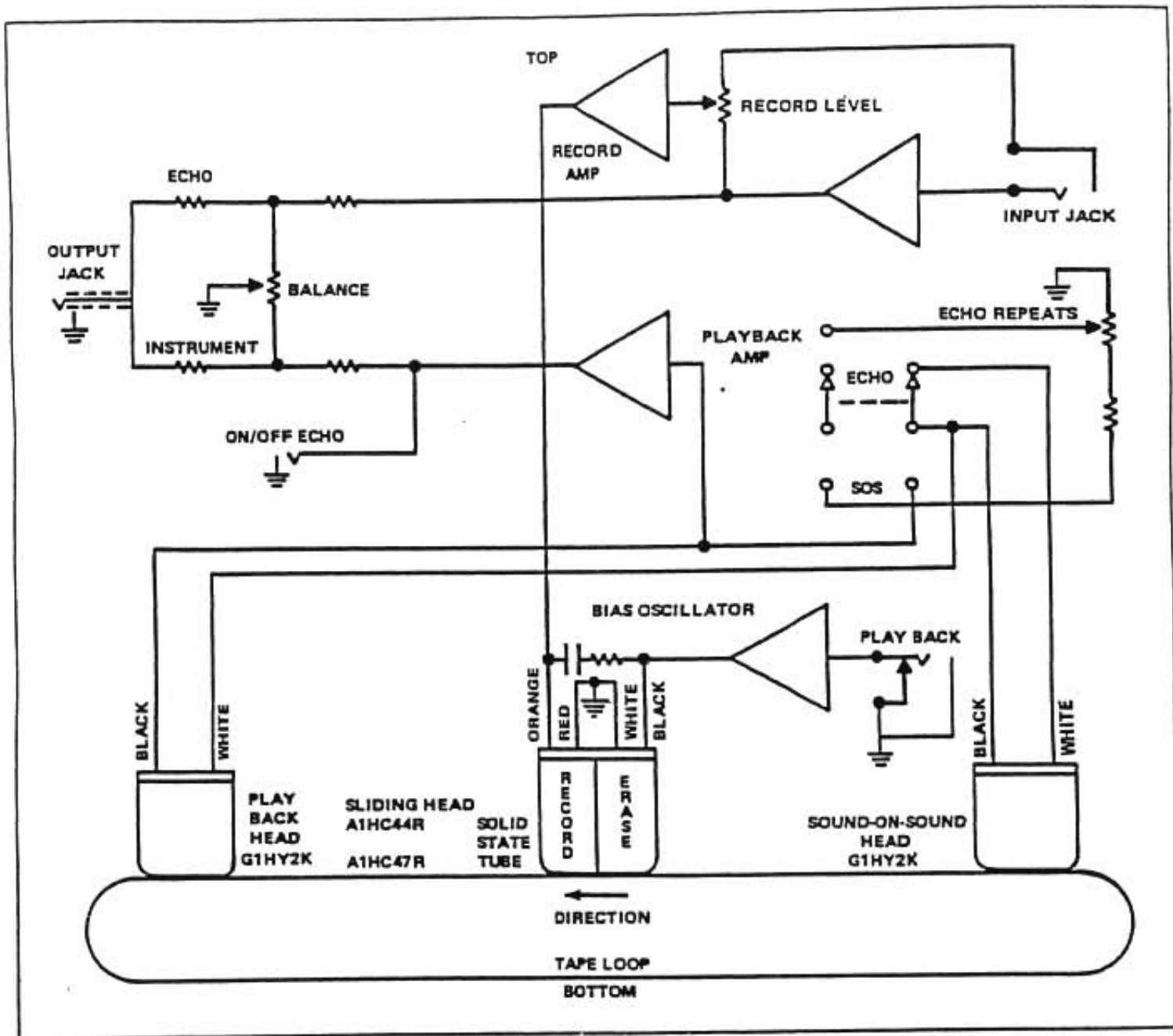

FUNCTIONAL BLOCK DIAGRAM
OF ECHOPLEX AND GROUPMASTER UNIT

EQUIPMENT REQUIRED

Oscilloscope, Audio Signal Generator and VU Meter or AC Voltmeter.

CONTROL SETTING

Set **ECHO VOLUME** to **MAXIMUM**, **ECHO SUSTAIN** to **MINIMUM** and **ECHO DELAY** to **MAXIMUM**.

BRIDGE ALIGNMENT

Loosen screws holding bridge, and tighten them while spacing bridge approximately 1/8 inch from cover studs located near each end of bridge.

HEAD ALIGNMENT

a) Using your eyesight as your judge, adjust the sliding record/erase head until it is level, and the tape passes the head evenly and smoothly.

b) Make sure tape is flat against the head. Move slider across bridge and observe that tape height on playback head does not change. If tape height does change, place a thin washer under the low side of the bridge to level it.

PLAYBACK HEAD

(Left Head, Looking At Front Of Machine)

a) Set signal generator to 1000Hz sine wave and connect to INPUT jack. Set ECHO DELAY to MAXIMUM.

b) Using needle nose pliers, gently bend playback head mounting bracket up and down until the maximum sine wave is obtained. Use caution not to break metal bracket loose from bridge. Move slider across and observe level change ± 3 dB. If out of specification, repeat step b with ECHO DELAY at MINIMUM.

c) Using trimmer potentiometer adjusting tool, turn trimmer potentiometer on the oscillator board until maximum sine wave is obtained with ECHO DELAY at MAXIMUM.

d) Set signal generator to 6000Hz.

e) Using pliers, turn head horizontally (clockwise or counterclockwise) until maximum wave is obtained.

f) Slide record head along bridge, stopping at each numbered delay position observing oscilloscope that the 6000Hz wave holds maximum heights as much as possible. Make any readjustments needed if wave drops considerably. Slide head next to playback head and check wave. This is necessary for echoing effect.

g) Return signal generator to 100Hz. Turn ECHO SUSTAIN control to position "1". Turn ECHO VOLUME control to position "9". Using small screwdriver, adjust record level by matching sine waves on ECHO VOLUME control in positions "1" and "9".

h) Remove input plug enough to stop incoming signal.

i) Turn ECHO VOLUME to position "6", "7" or "8". Turn ECHO SUSTAIN control to approximately "6" or "7".

j) Quickly push and pull input in far enough to record a signal and pull plug out, and listen or watch for the echoing effect. If unit is set and aligned properly, there should not be any problems. If echo begins, but fades away, turn ECHO SUSTAIN to a higher position, "7" or "8".

k) Slide record head away from present position and test for echo once again.

SOUND ON SOUND HEAD ALIGNMENT

a) Record approximately one minute of 1000Hz, no echoing, and approximately one minute of 6000 Hz, no echoing. Connect VU meter to unused connection terminal on record board, next to orange voltage wire. Set VU meter to 100 percent.

b) Place foot switch in PLAYBACK jack, and shut off when record time is complete.

c) Adjust sound on sound head same as playback, and flip ECHO SOUND ON SOUND switch until both heads produce approximately the same wave amplitude on both frequencies.

d) Turn foot switch on. During 1000Hz playback, with switch in SOUND ON SOUND position, adjust trimmer potentiometer on playback board until VU meter reads 95 percent.

e) Each time the 1000Hz passes, the VU meter should drop approximately 1dB. If VU meter does not drop 1dB, turn the trimmer potentiometer a little more until the desired results are obtained.

f) Glue heads in this position to maintain setup.

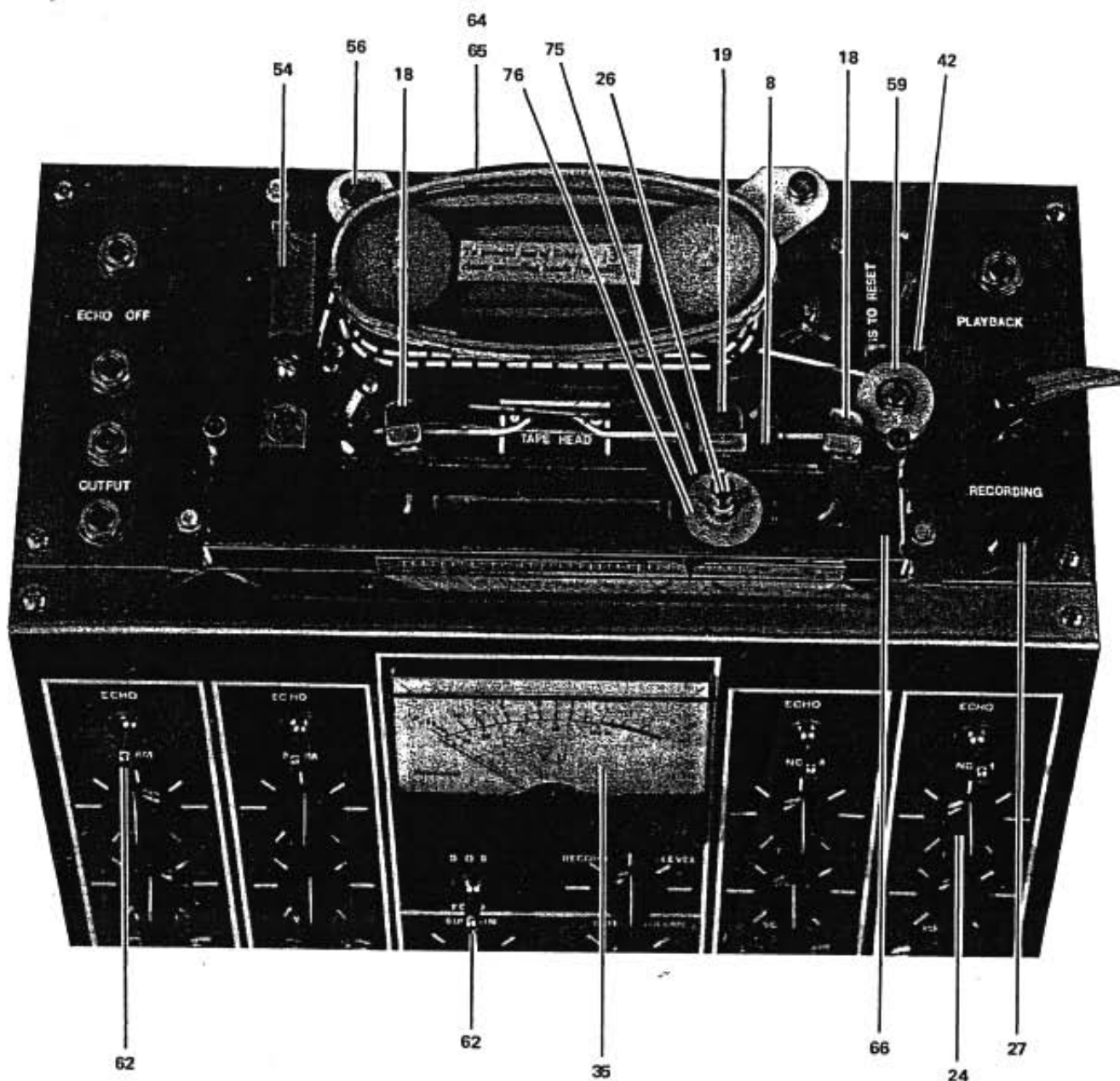

GROUPMASTER EM-1, FRONT AND TOP VIEW

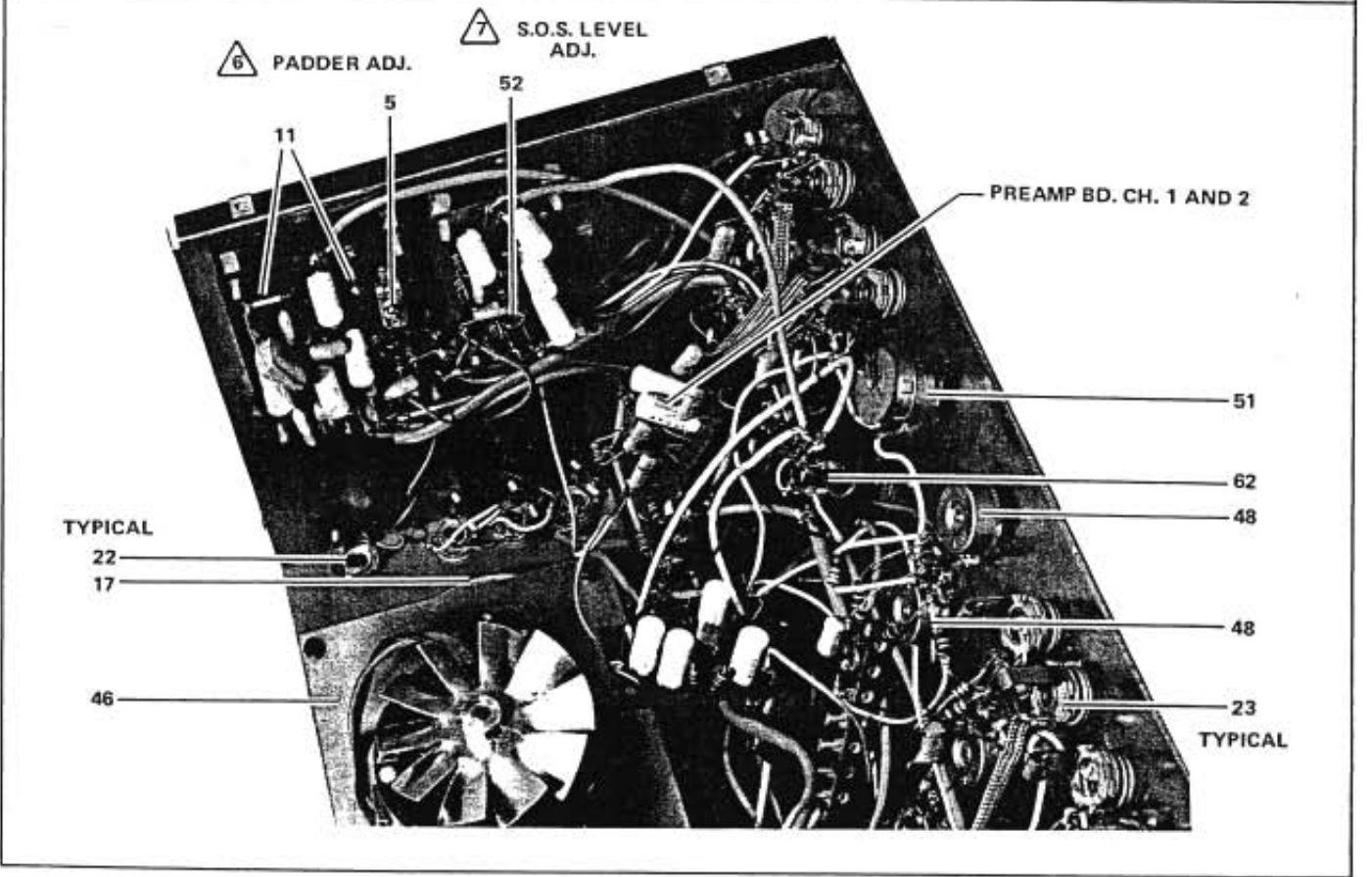
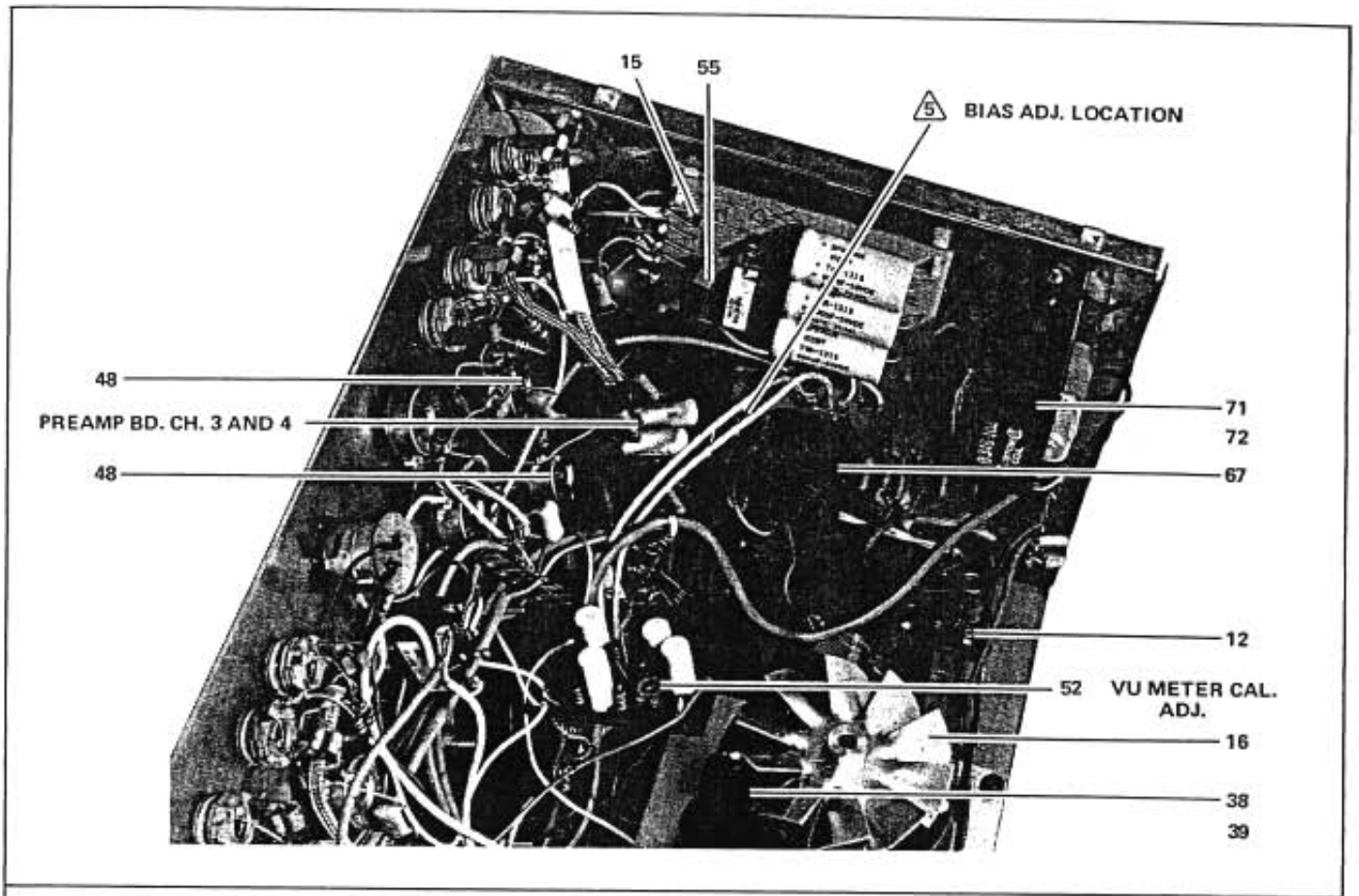

GROUPMASTER EM-1, INSIDE COMPONENT VIEWS

PC BOARD GM101
TWO PRE AMPS PER BOARD

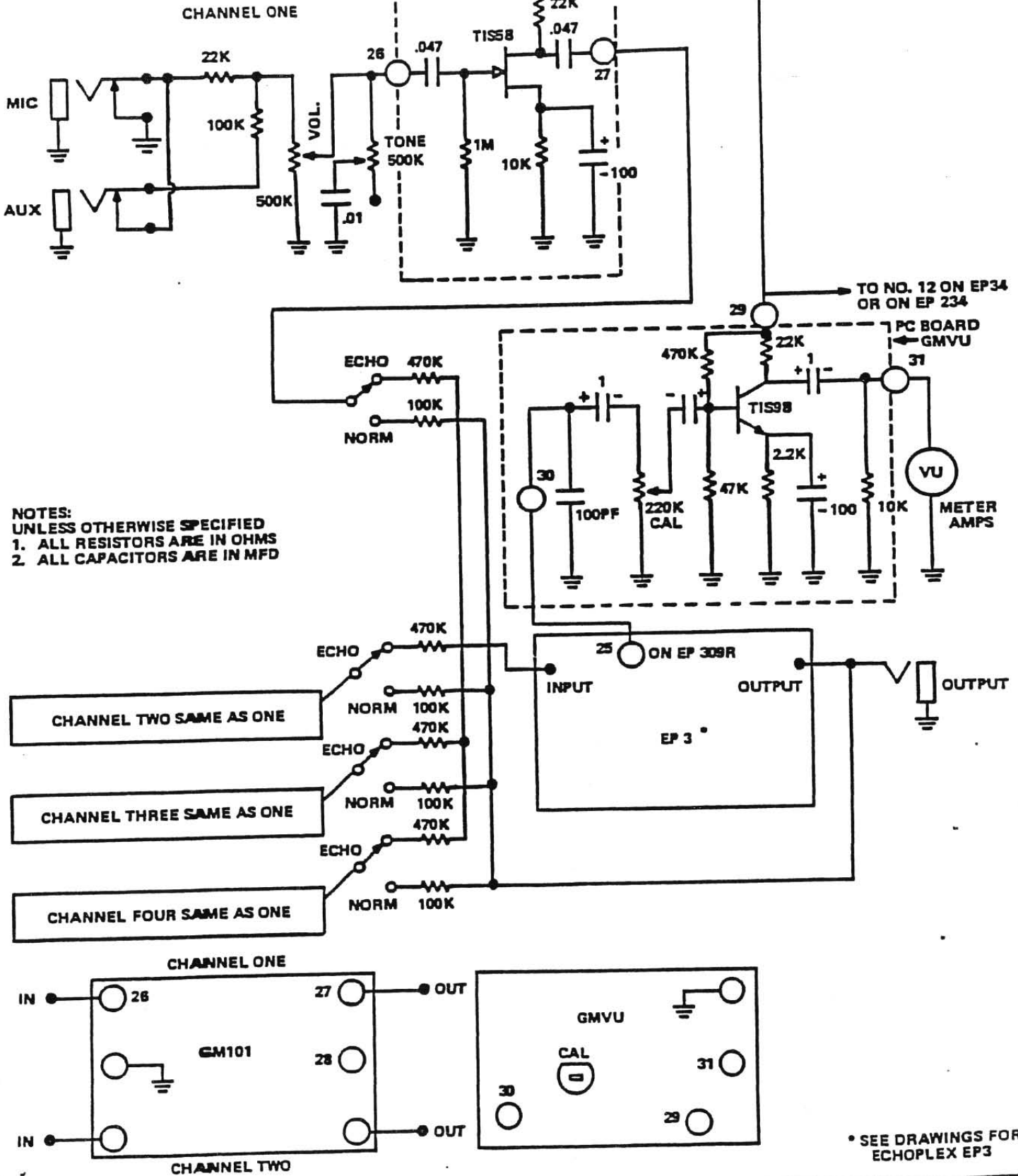

* SEE DRAWINGS FOR ECHOPLEX EP3

GROUPMASTER EM-1 SCHEMATIC DIAGRAM

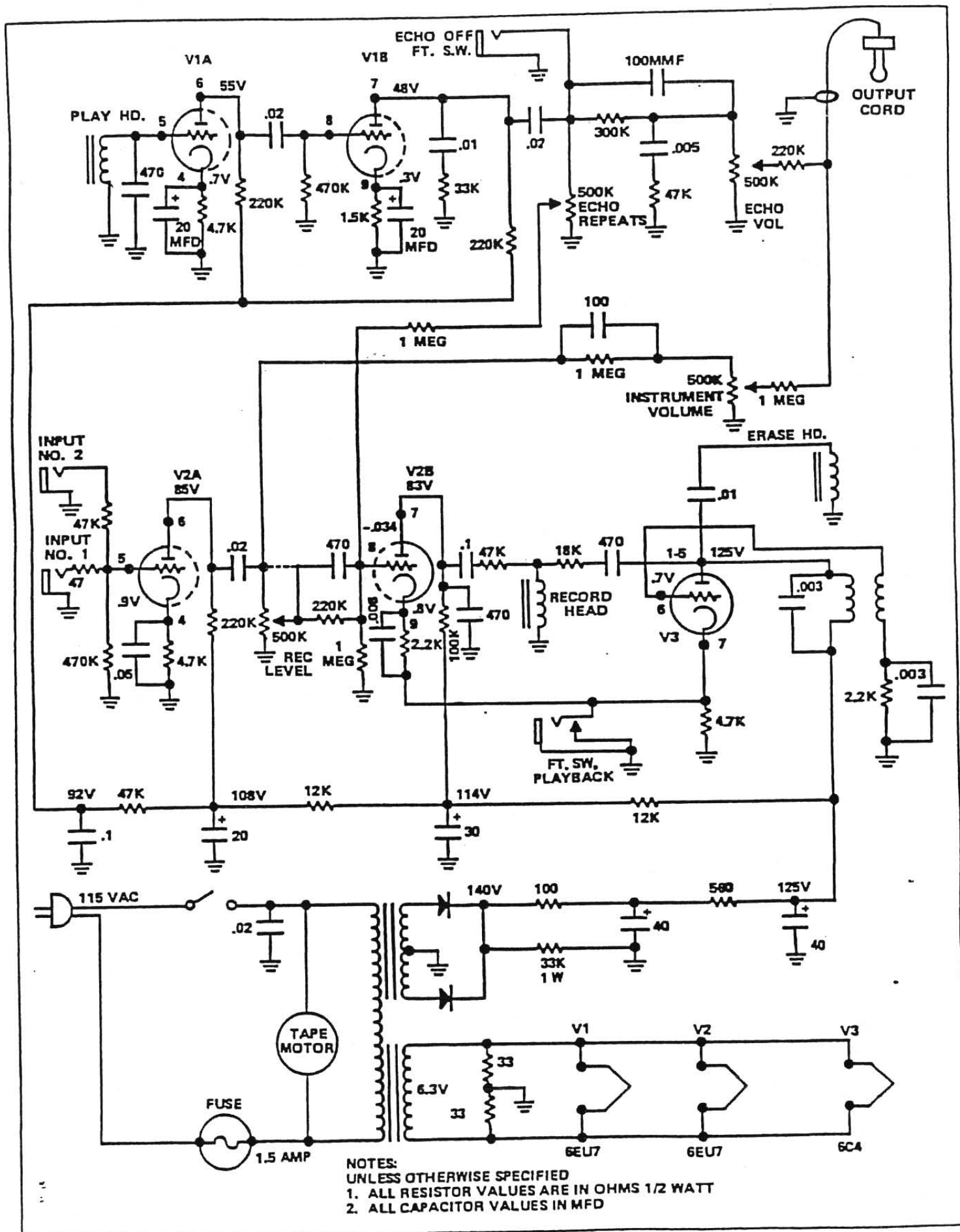

ECHOPLEX EP-1 MODEL NO. 5000 SCHEMATIC DIAGRAM

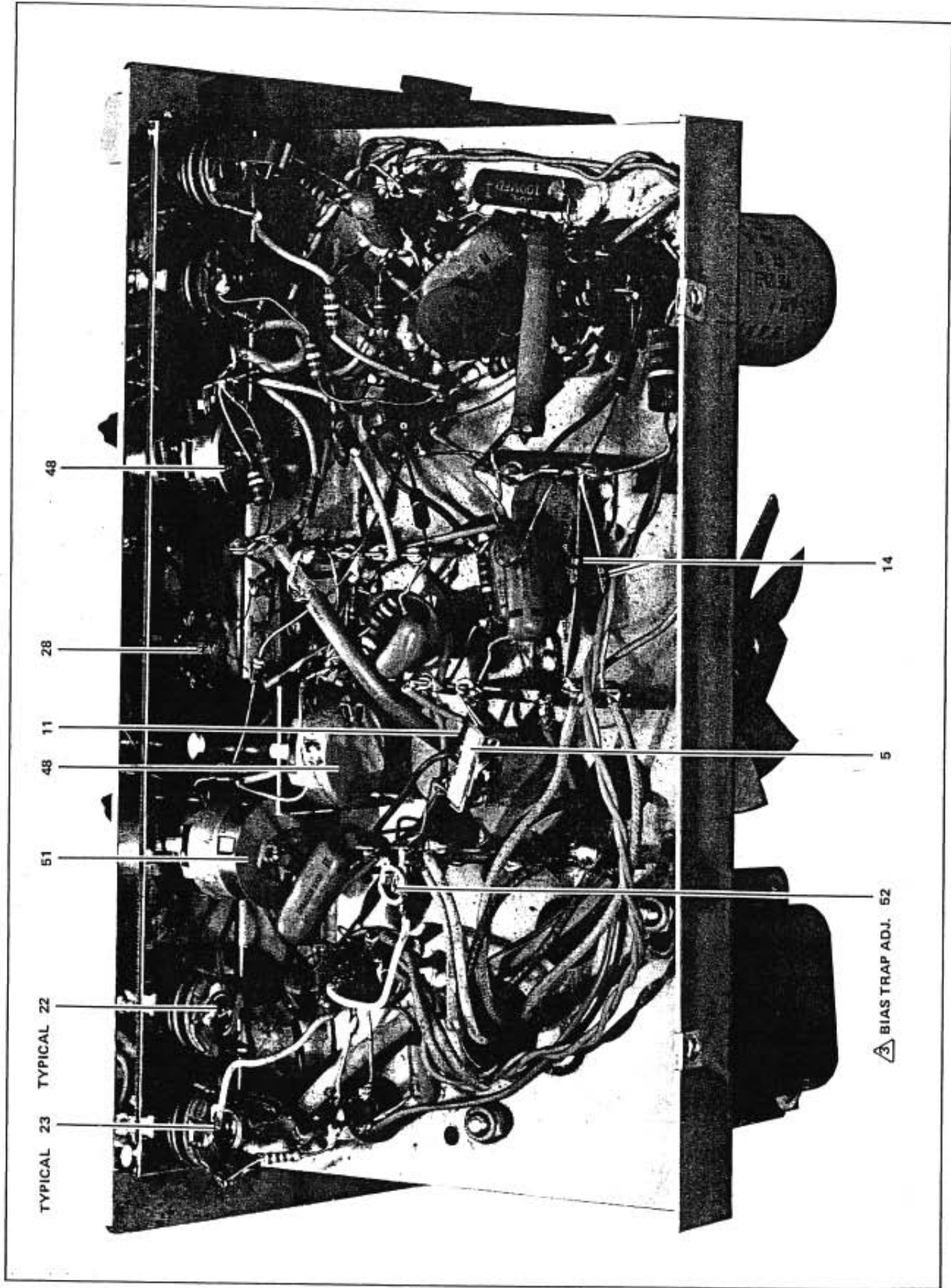

TYPICAL 23 TYPICAL 22

51

48

11

28

48

⚠ BIAS TRAP ADJ. 52

5

14

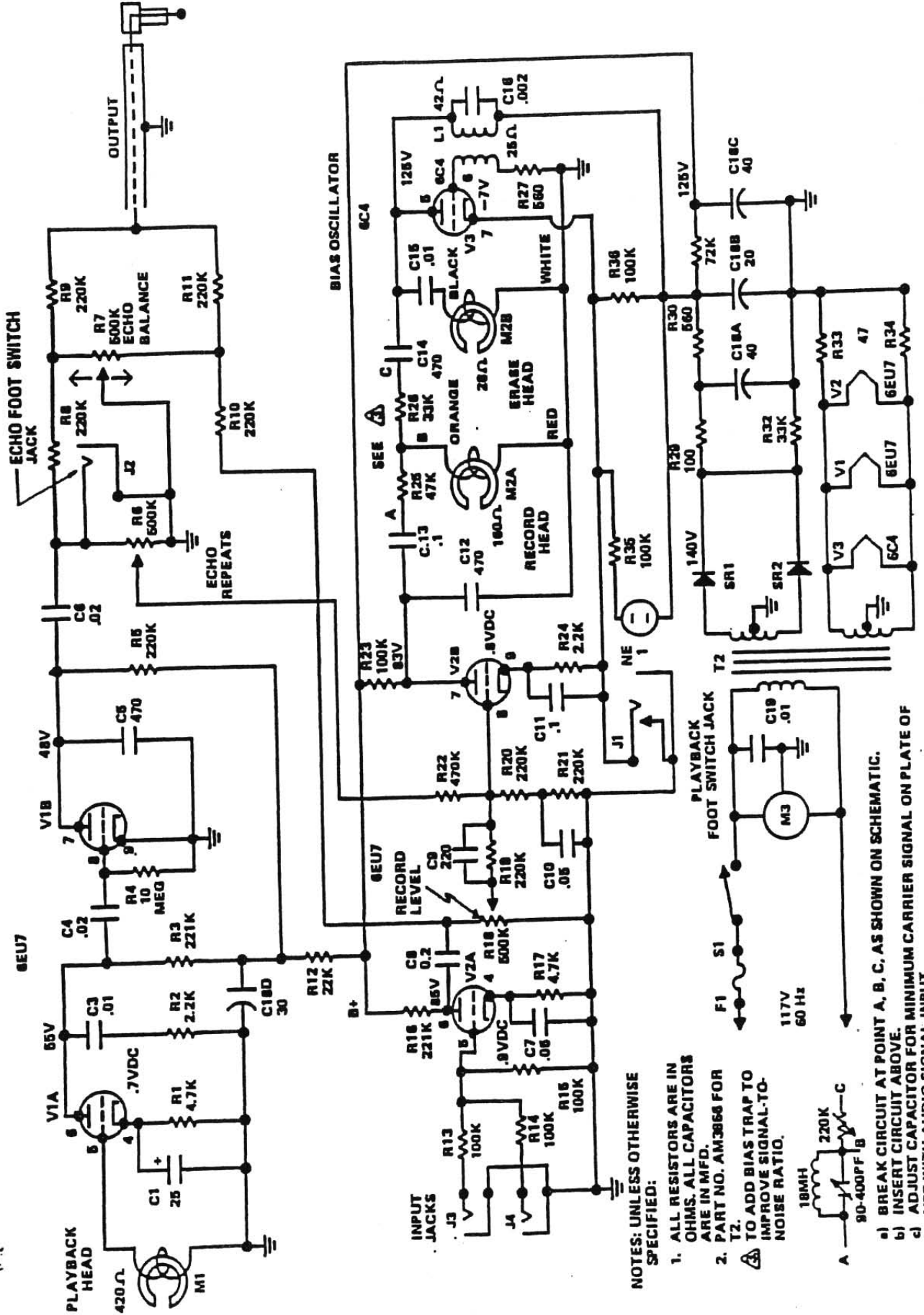

NOTES: UNLESS OTHERWISE SPECIFIED:

1. ALL RESISTORS ARE IN OHMS. ALL CAPACITORS ARE IN MFD.
 2. T2. PART NO. AM3856 FOR TO ADD BIAS TRAP TO IMPROVE SIGNAL-TO-NOISE RATIO.
- A $\begin{matrix} 18\text{MH} \\ \text{---} \\ 80\text{-}400\text{PF } B \end{matrix}$ C
- a) BREAK CIRCUIT AT POINT A, B, C, AS SHOWN ON SCHEMATIC.
 - b) INSERT CIRCUIT ABOVE.
 - c) ADJUST CAPACITOR FOR MINIMUM CARRIER SIGNAL ON PLATE OF V2B WITH AUDIO SIGNAL INPUT.
 - d) ADJUST RESISTOR FOR MAXIMUM OUTPUT SIGNAL WITH 100MV, 1KHZ INPUT.

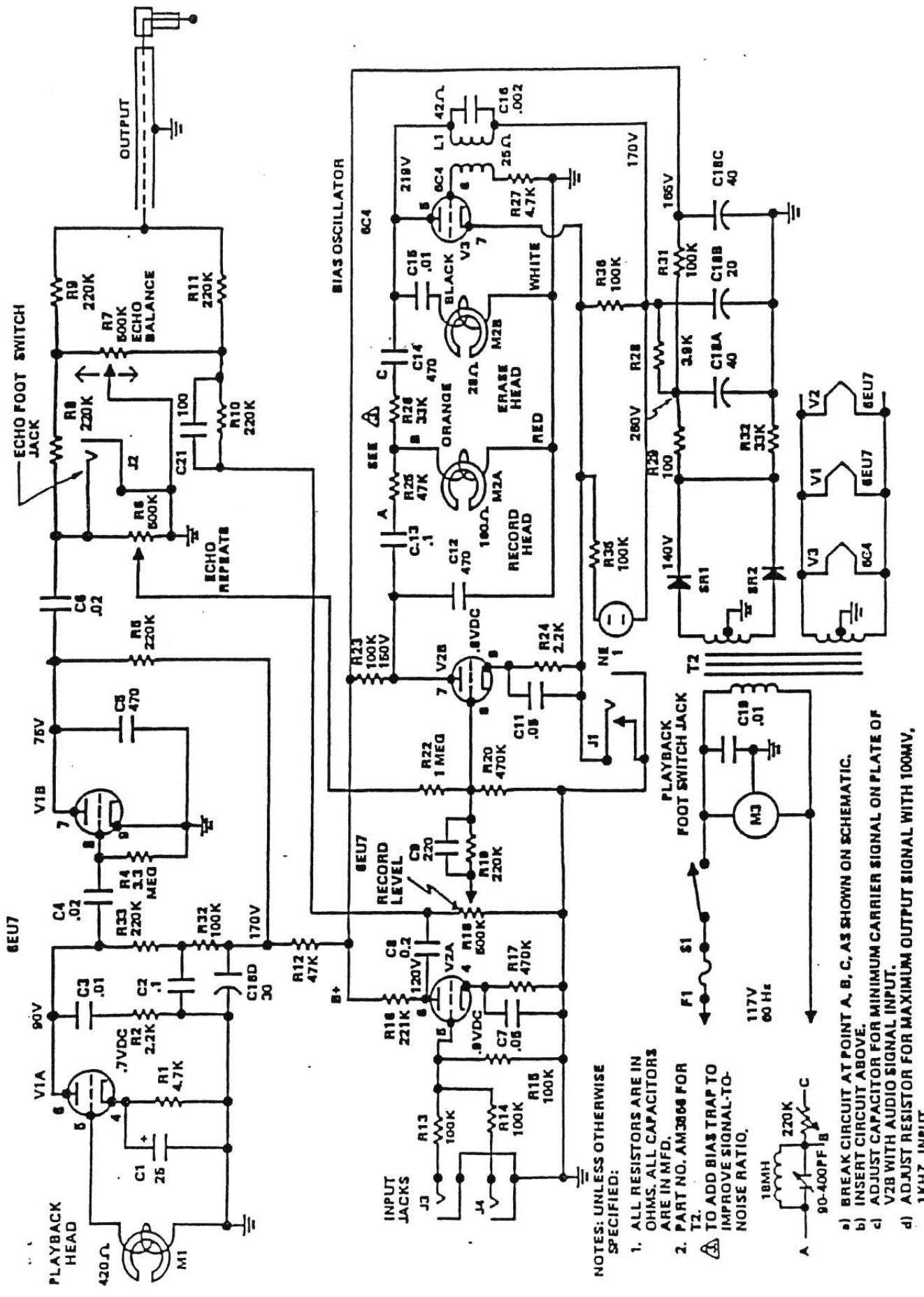

- NOTES: UNLESS OTHERWISE SPECIFIED:
1. ALL RESISTORS ARE IN OHMS. ALL CAPACITORS ARE IN MFD.
 2. PART NO. AM3088 FOR Δ TO ADD BIAS TRAP TO IMPROVE SIGNAL-TO-NOISE RATIO.
- 18MH
90-400PF
- a) BREAK CIRCUIT AT POINT A, B, C, AS SHOWN ON SCHEMATIC.
 - b) INSERT CIRCUIT ABOVE.
 - c) ADJUST CAPACITOR FOR MINIMUM CARRIER SIGNAL ON PLATE OF V2B WITH AUDIO SIGNAL INPUT.
 - d) ADJUST RESISTOR FOR MAXIMUM OUTPUT SIGNAL WITH 100MV, 1KHZ INPUT.

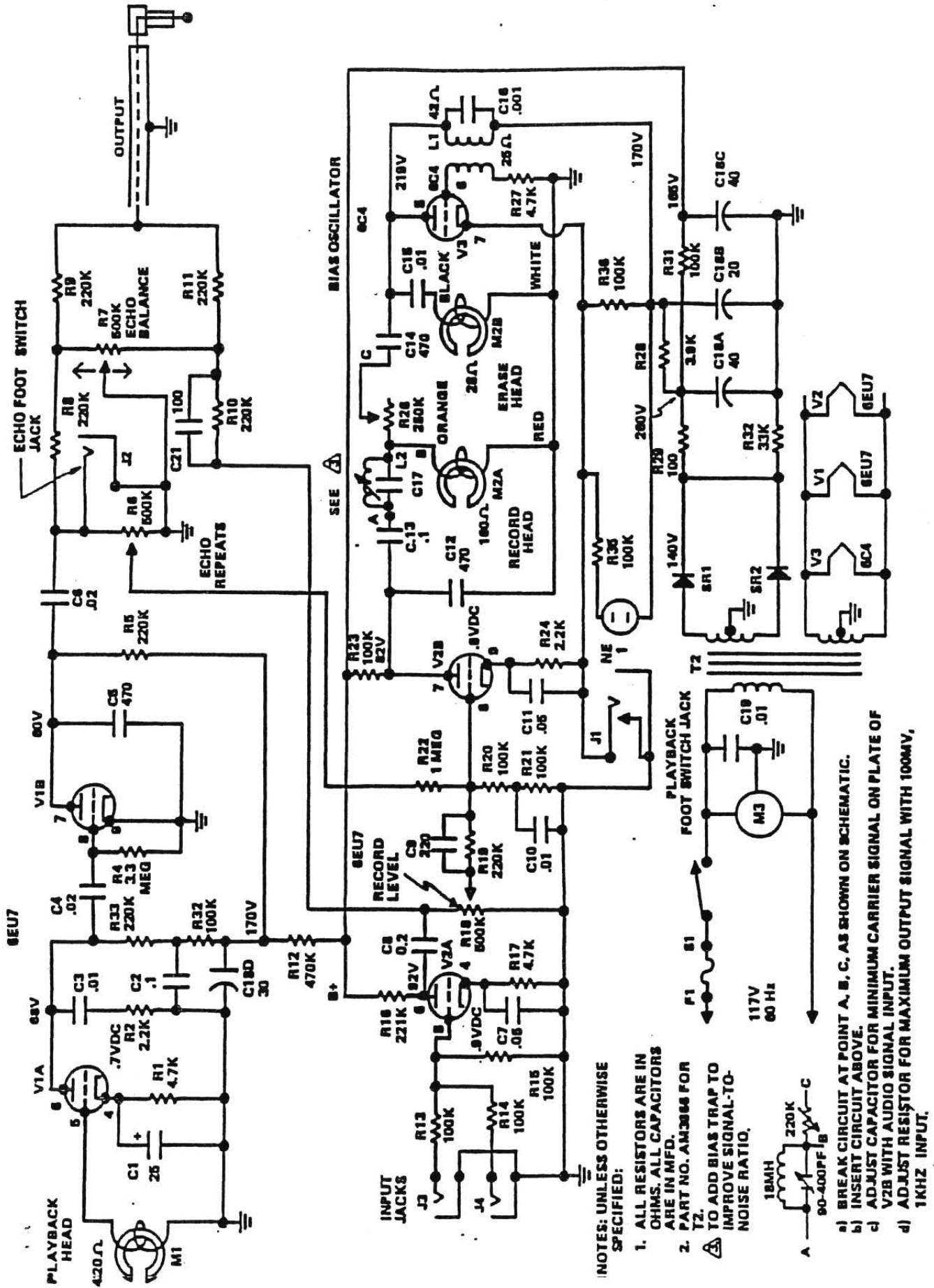

NOTES: UNLESS OTHERWISE SPECIFIED:

1. ALL RESISTORS ARE IN OHMS. ALL CAPACITORS ARE IN MFD.
2. PART NO. AM3066 FOR T2.
- △ TO ADD BIAS TRAP TO IMPROVE SIGNAL-TO-NOISE RATIO.
- a) BREAK CIRCUIT AT POINT A, B, C, AS SHOWN ON SCHEMATIC.
- b) INSERT CIRCUIT ABOVE.
- c) ADJUST CAPACITOR FOR MINIMUM CARRIER SIGNAL ON PLATE OF V2B WITH AUDIO SIGNAL INPUT.
- d) ADJUST RESISTOR FOR MAXIMUM OUTPUT SIGNAL WITH 100MV, 1KHZ INPUT.

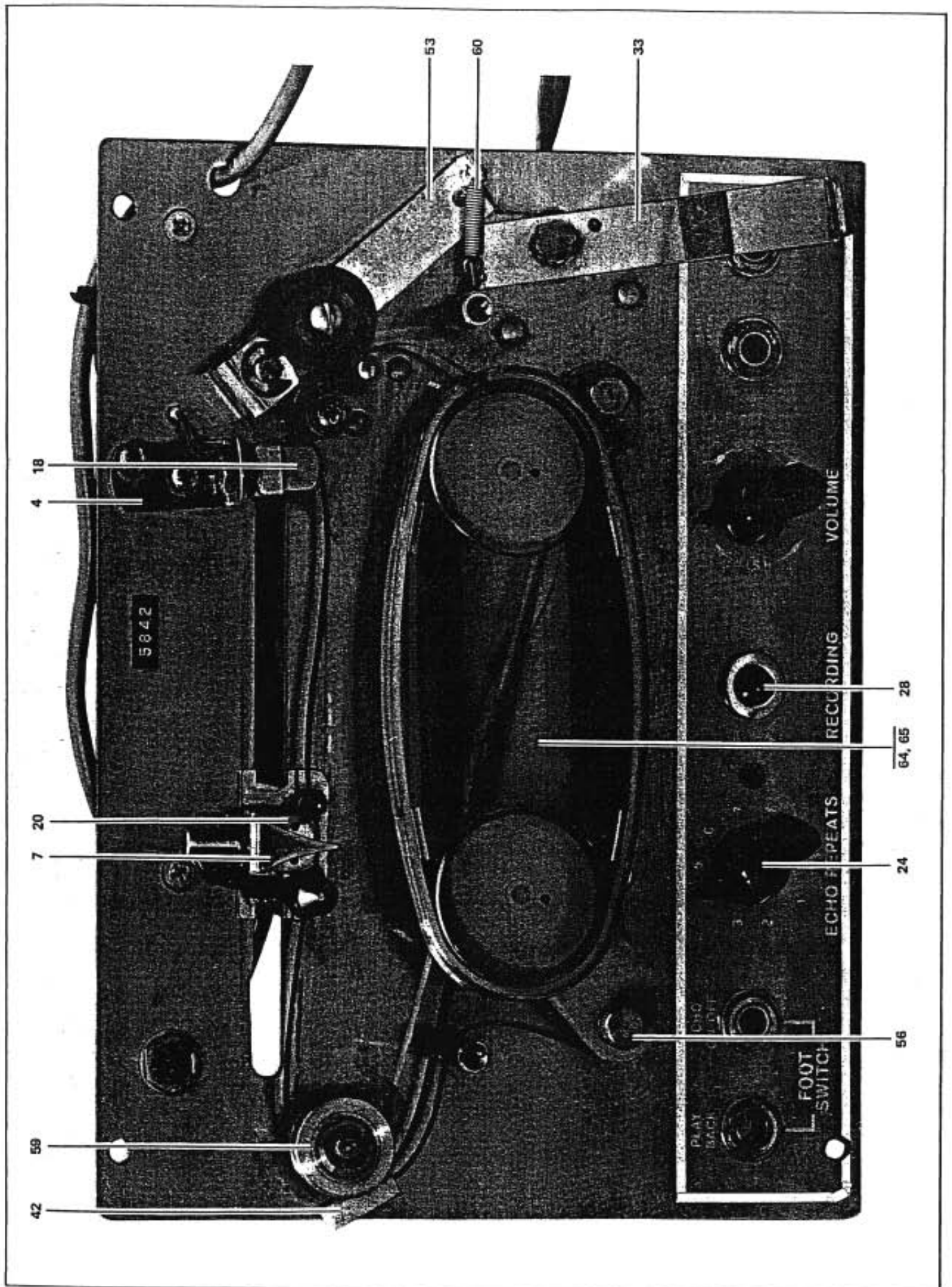

ECHOPLEX EP-1 AND EP-2, TOP VIEW

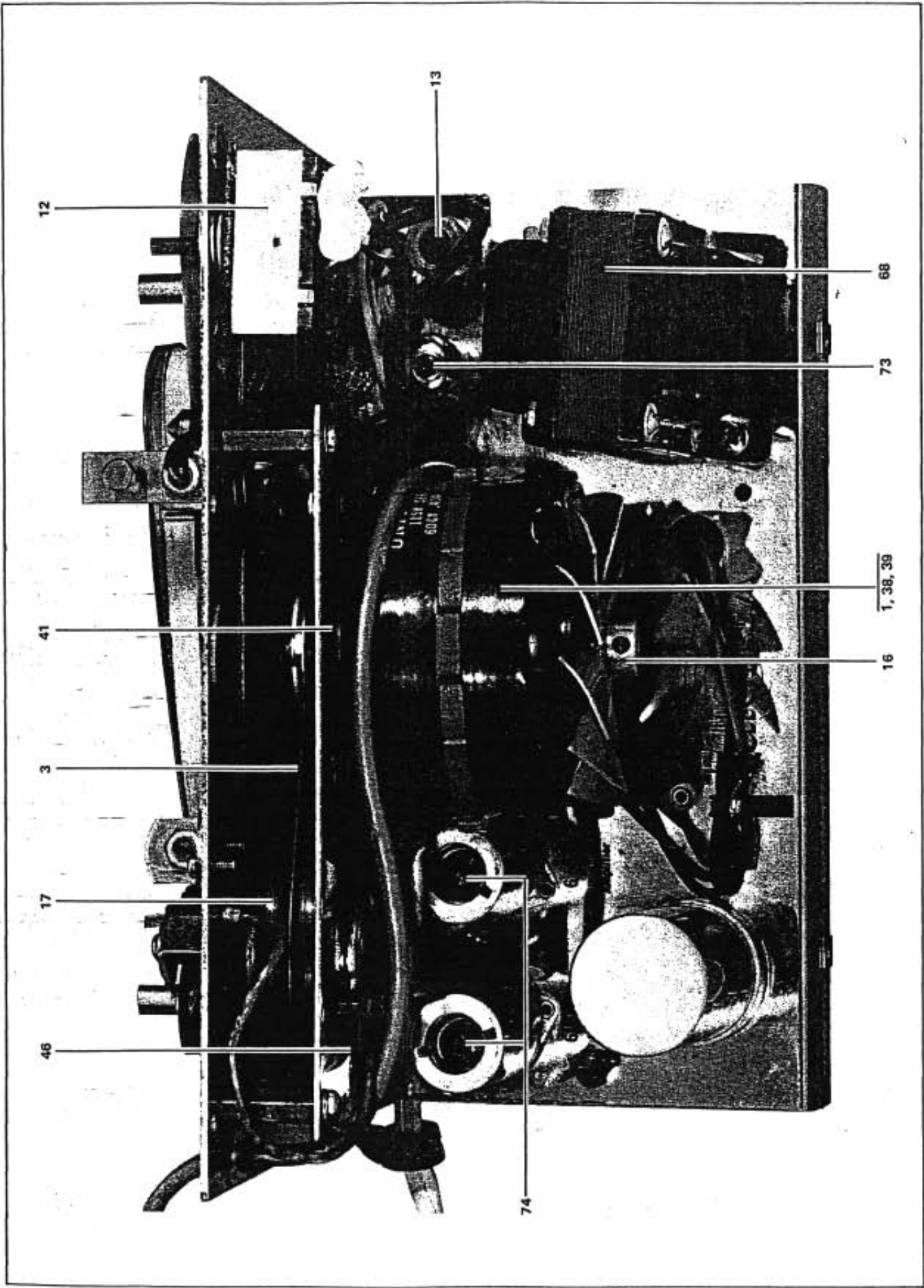

ECHOPLEX EP-1 AND EP-2, INSIDE TOP COMPONENT VIEW

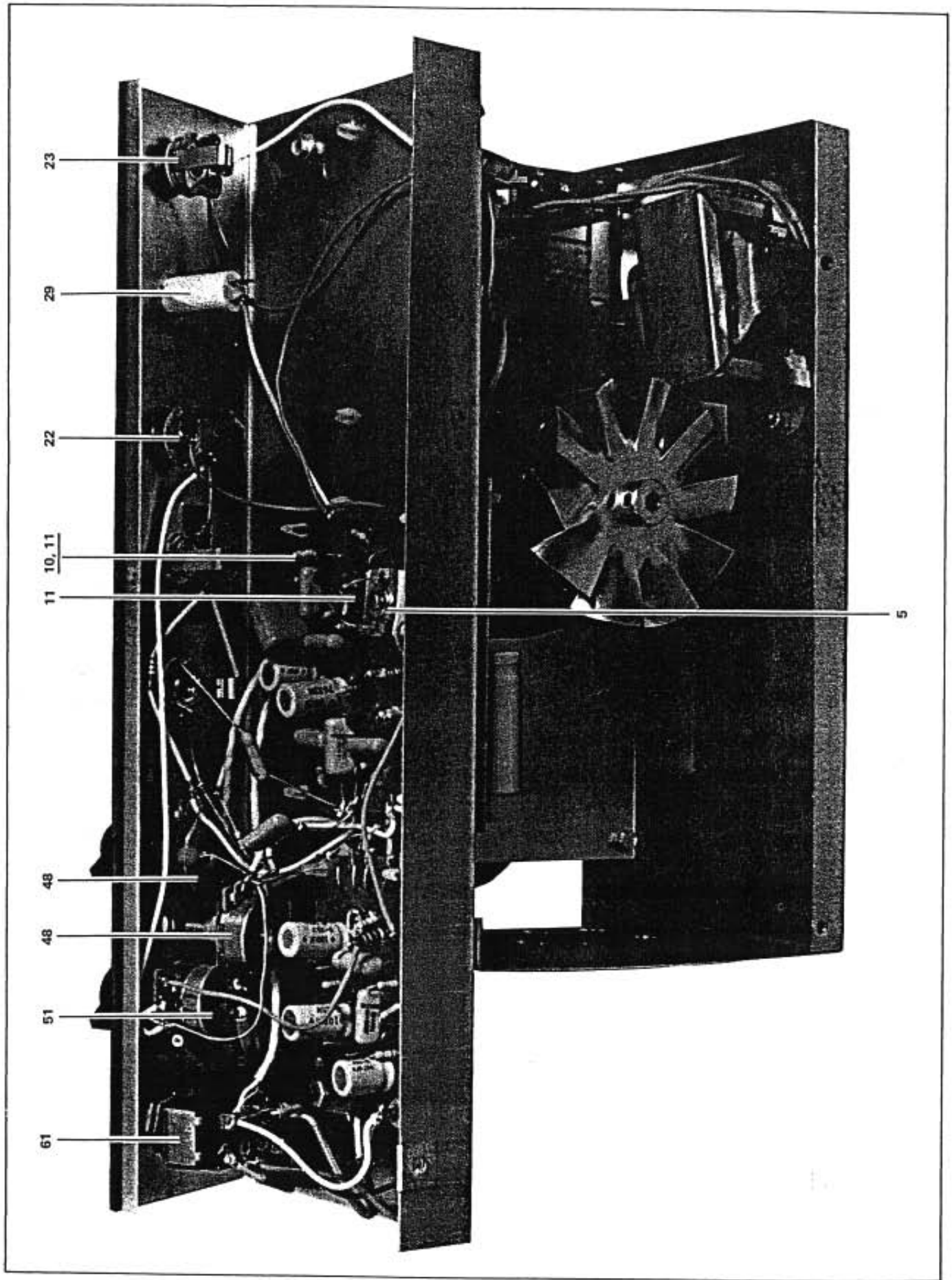

ECHOPLEX EP-3 - INSIDE VIEW

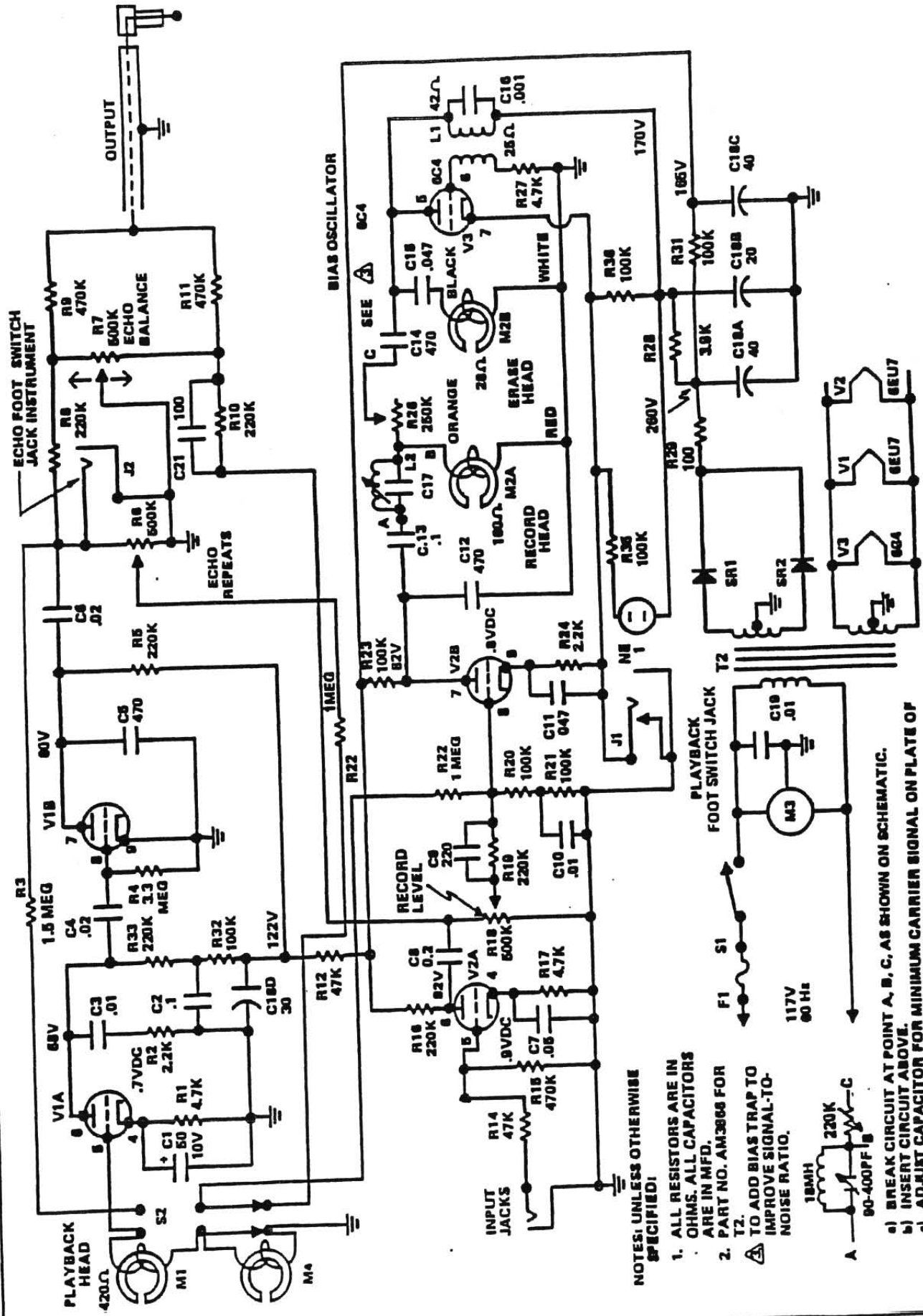

- NOTES: UNLESS OTHERWISE SPECIFIED:**
1. ALL RESISTORS ARE IN OHMS, ALL CAPACITORS ARE IN MFD.
 2. PART NO. AM3866 FOR T2.
- TO ADD BIAS TRAP TO IMPROVE SIGNAL-TO-NOISE RATIO.**
- A 18MH 220K 90-400PF C
- a) BREAK CIRCUIT AT POINT A, B, C, AS SHOWN ON SCHEMATIC.
 - b) INSERT CIRCUIT ABOVE.
 - c) ADJUST CAPACITOR FOR MINIMUM CARRIER SIGNAL ON PLATE OF V2B WITH AUDIO SIGNAL INPUT.
 - d) ADJUST RESISTOR FOR MAXIMUM OUTPUT SIGNAL WITH 100MV, 1KHZ INPUT.

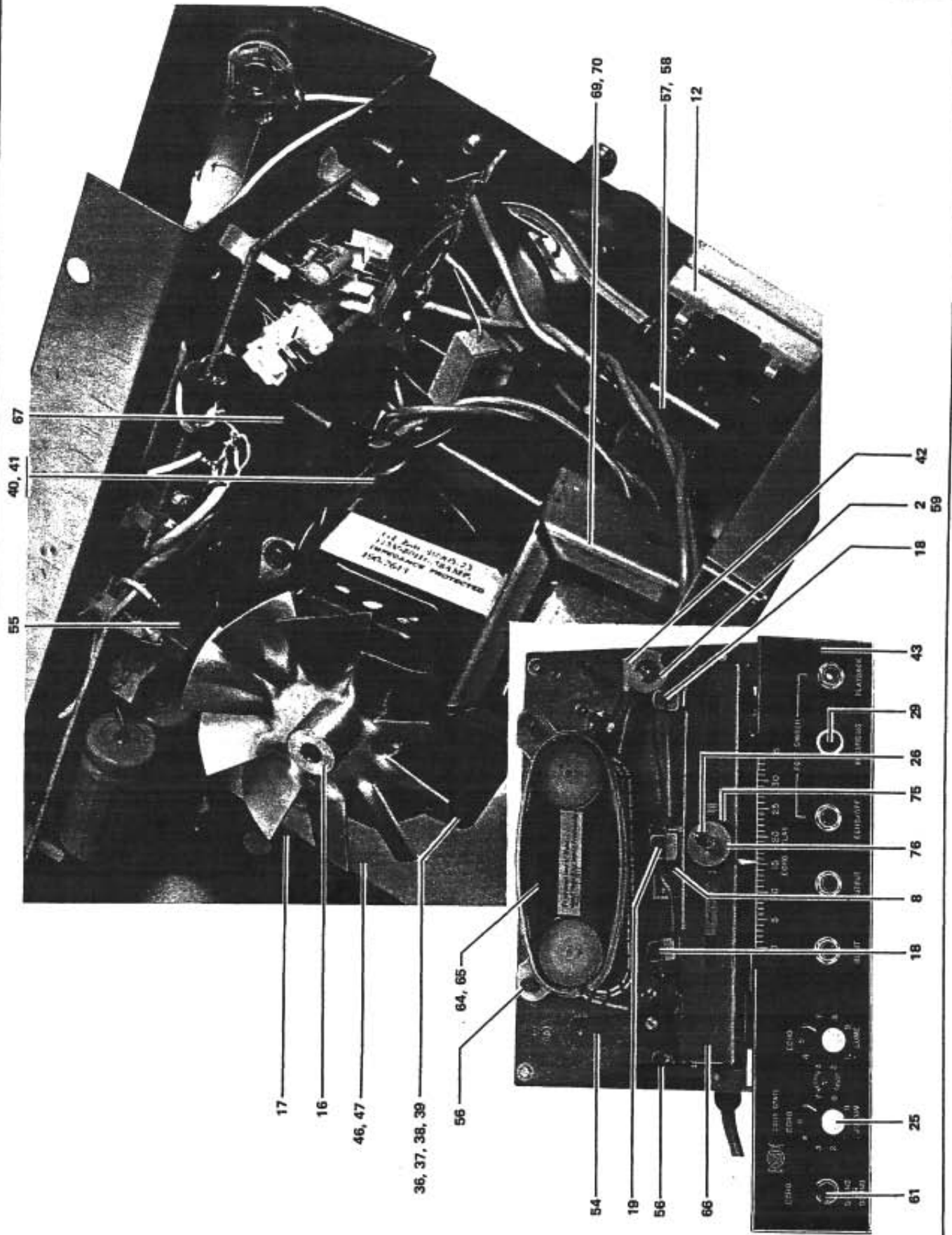

ECHOPLEX EP-3, TOP AND INSIDE VIEWS

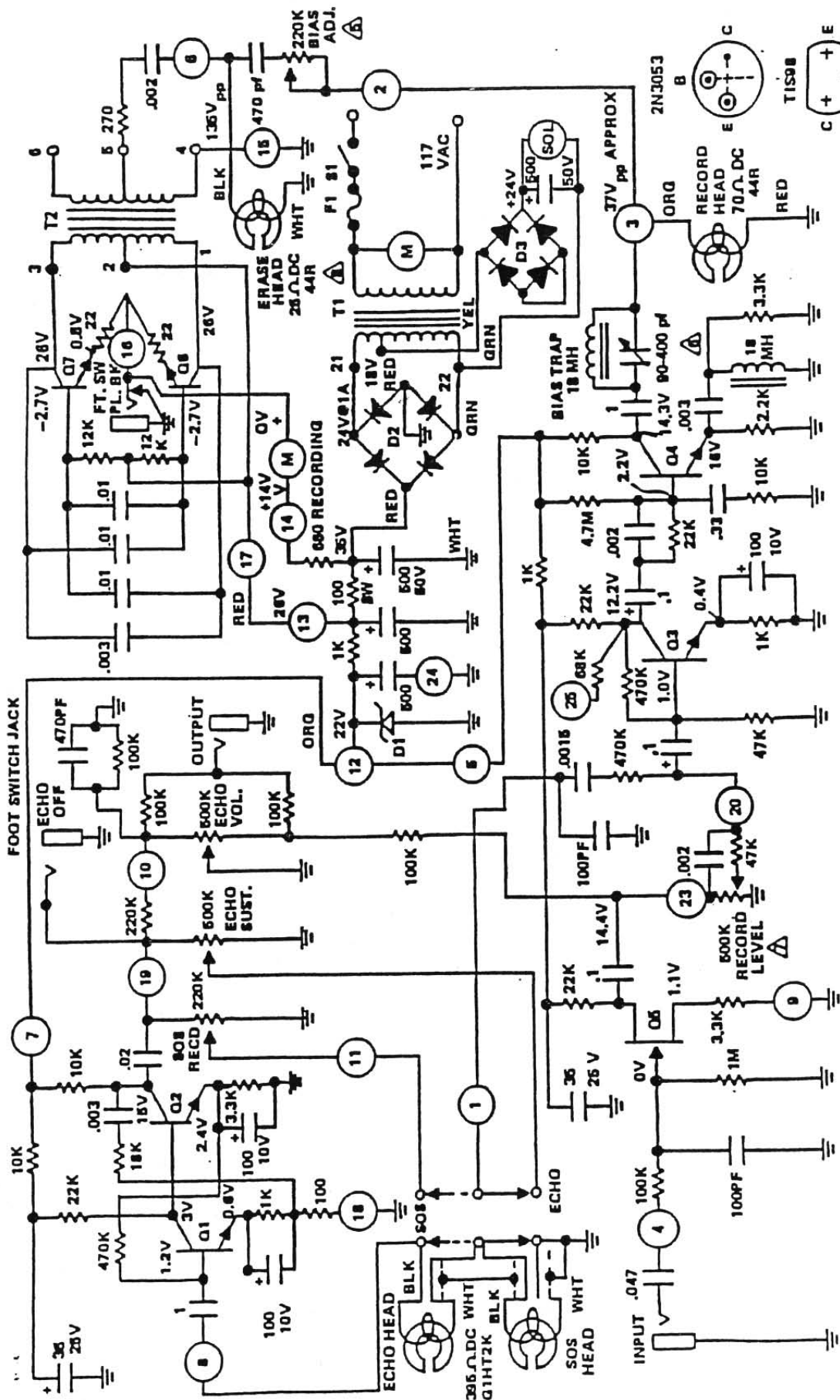

- NOTES: UNLESS OTHERWISE SPECIFIED -
1. ALL RESISTOR VALUES ARE IN OHMS 1/2 WATT.
 2. ALL VOLTAGES \pm 20%.
 3. OPC BOARD TERMINALS.
 4. ALL CAPACITOR VALUES ARE IN MFD.
- ▲ ADJUST FOR MAX. UNDISTORTED OUTPUT 1kHz
 ▲ -20dB INPUT. ECHO SUSTAIN = 1, ECHO VOL. = 9.
 ▲ ADJUST FOR MINIMUM SIGNAL ON COLLECTOR Q4. NO SIGNAL IN.
 ▲ ADJUST FOR 20dB OUTPUT, -20dB 1kHz INPUT. ECHO SUSTAIN = 1, ECHO VOL. = 9.
 ▲ T1 B346-012 CUSTOM COIL.

D1 ZENER	1N4748
D2 BRIDGE	1A, 100V
Q1, Q2, Q3, Q4	T1S98
Q5	T1S58
Q6, Q7	2N3053
D3	IR, 100BIP

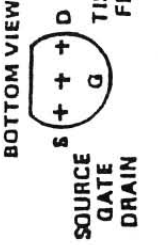

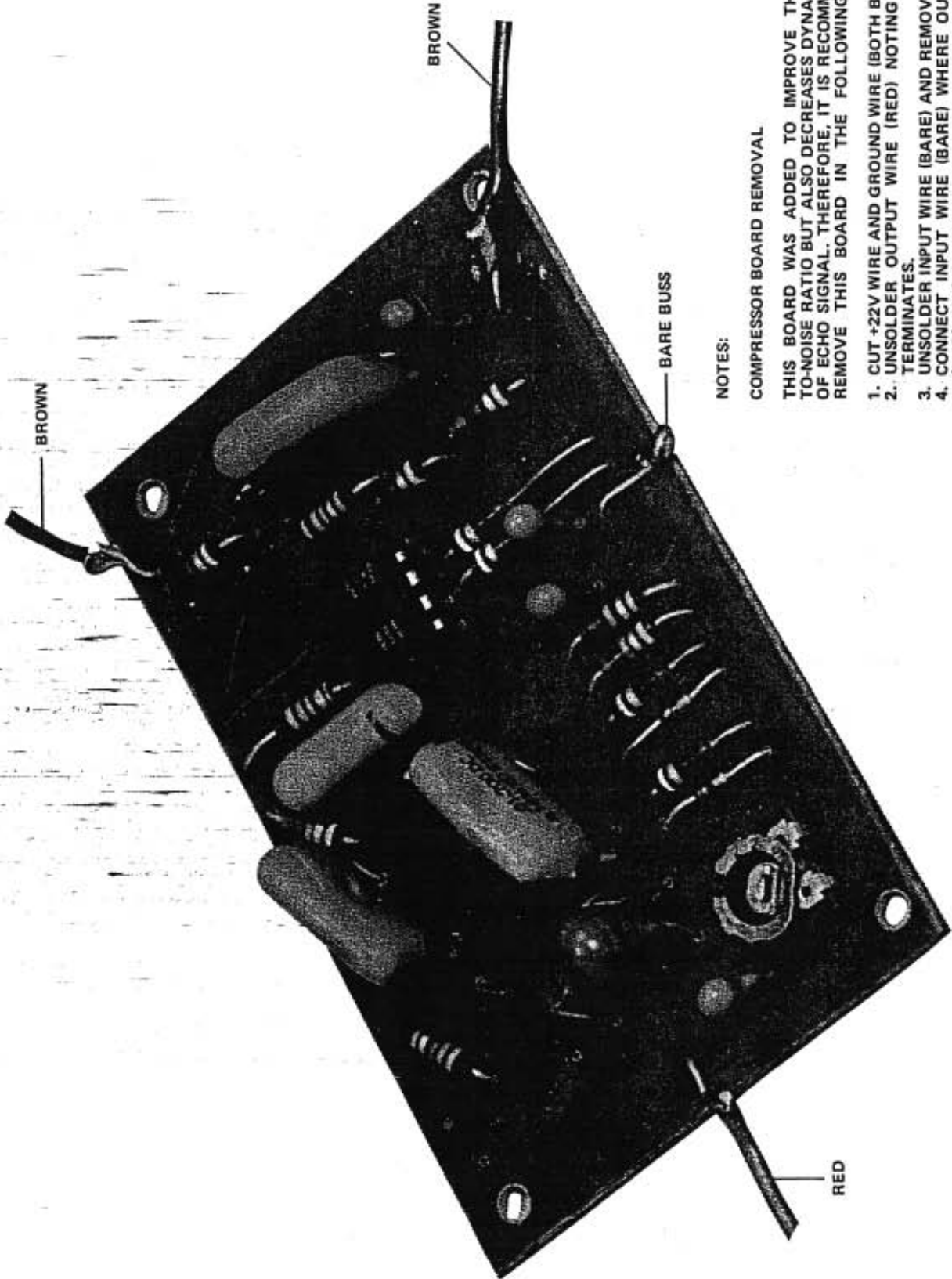

NOTES:

COMPRESSOR BOARD REMOVAL

THIS BOARD WAS ADDED TO IMPROVE THE SIGNAL-TO-NOISE RATIO BUT ALSO DECREASES DYNAMIC RANGE OF ECHO SIGNAL. THEREFORE, IT IS RECOMMENDED TO REMOVE THIS BOARD IN THE FOLLOWING MANNER:

1. CUT +22V WIRE AND GROUND WIRE (BOTH BROWN).
2. UNSOLDER OUTPUT WIRE (RED) NOTING WHERE IT TERMINATES.
3. UNSOLDER INPUT WIRE (BARE) AND REMOVE BOARD.
4. CONNECT INPUT WIRE (BARE) WHERE OUTPUT WIRE (RED) WAS REMOVED.

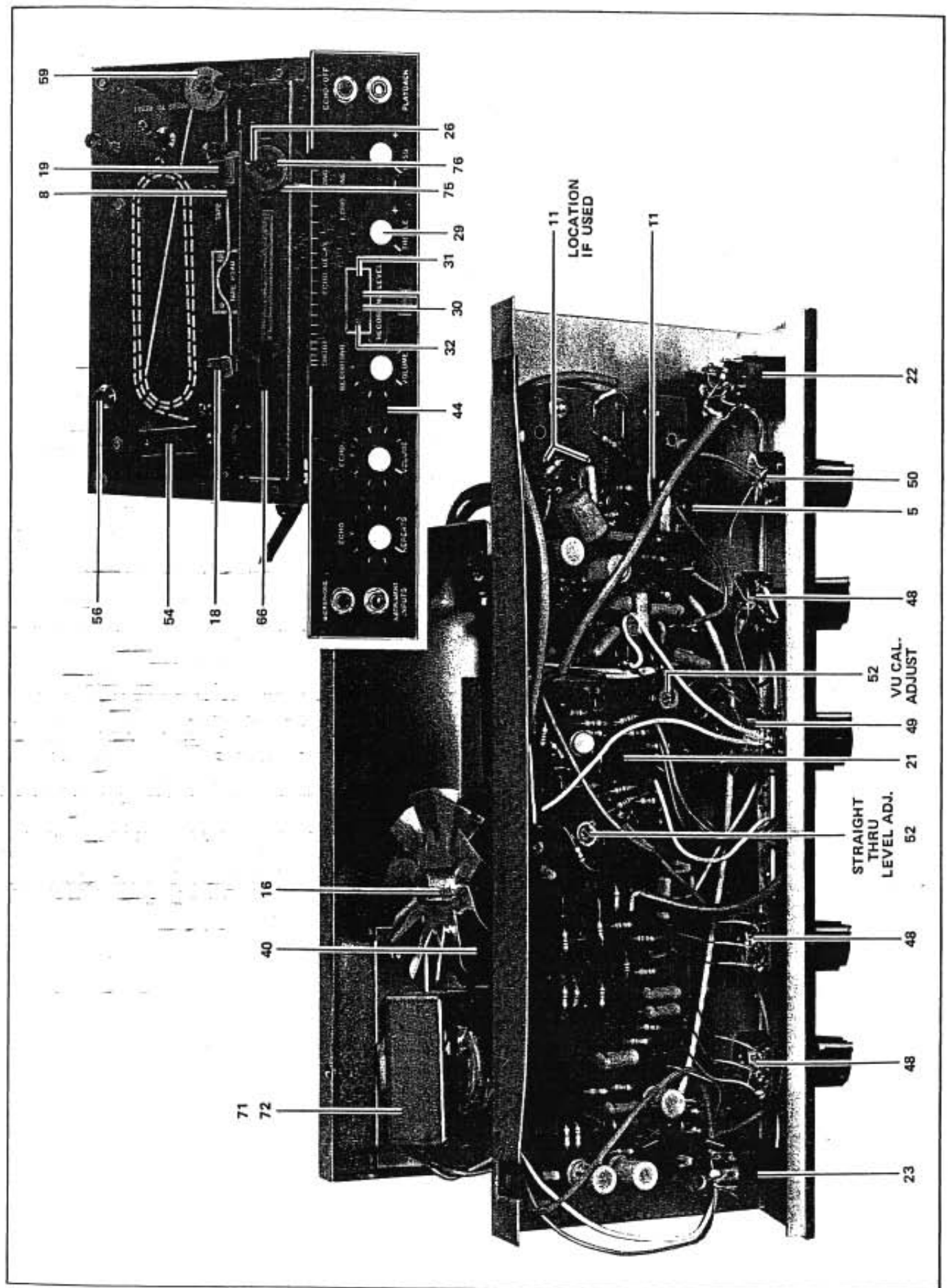

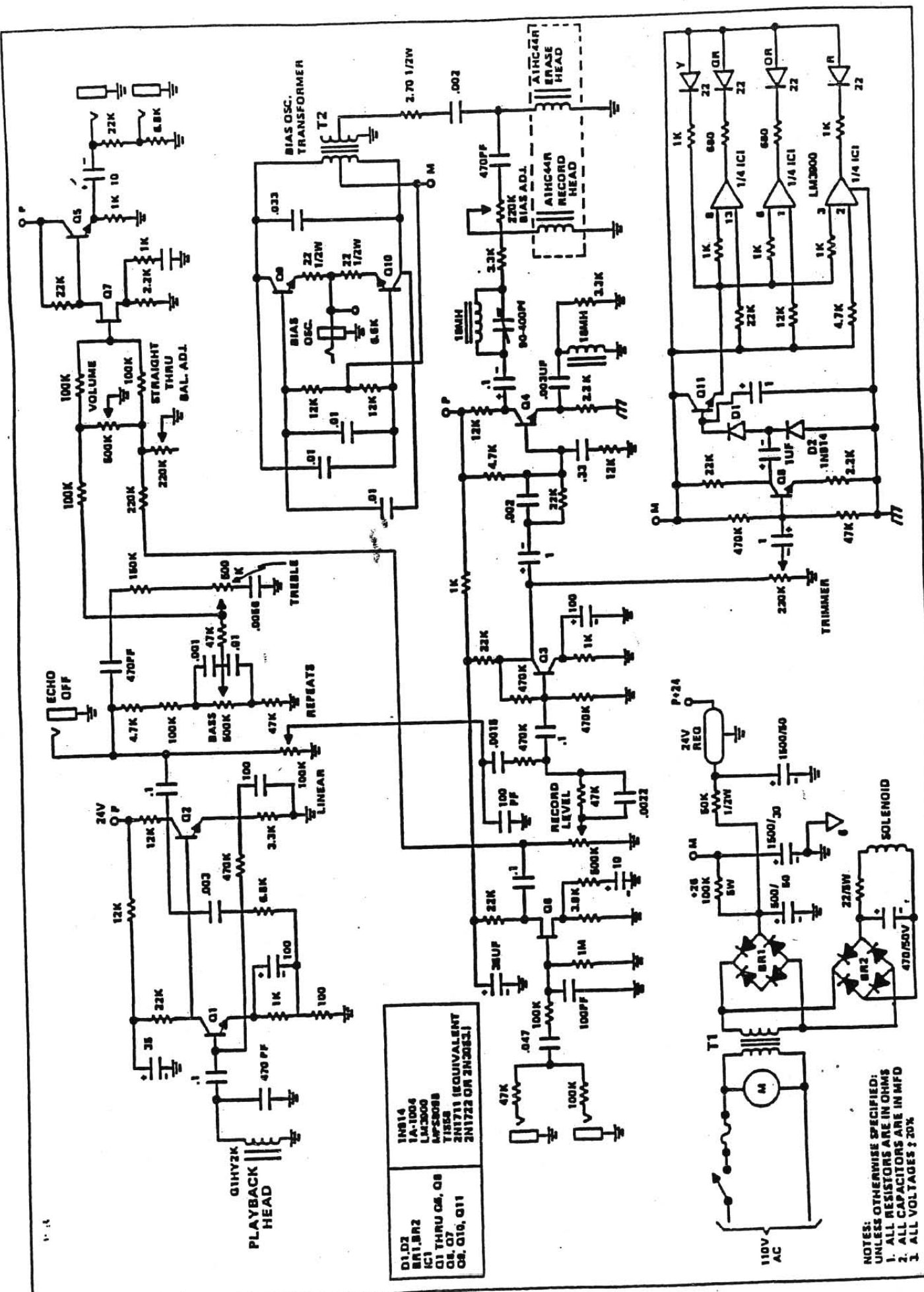

- | | |
|----------------|---|
| Q1, Q2 | 1N814 |
| BR1, BR2 | 1A-1004 |
| IC1 | LM3000 |
| Q3 THRU Q6, Q8 | MPF2008 |
| Q5, Q7 | TISS |
| Q8, Q10, Q11 | 2N1713 (EQUIVALENT
2N1723 OR 2N2053) |

NOTES:
UNLESS OTHERWISE SPECIFIED:
1. ALL RESISTORS ARE IN OHMS
2. ALL CAPACITORS ARE IN MFD
3. ALL VOLTAGES ± 20%

ECHOPLEX EP-4 SCHEMATIC DIAGRAM

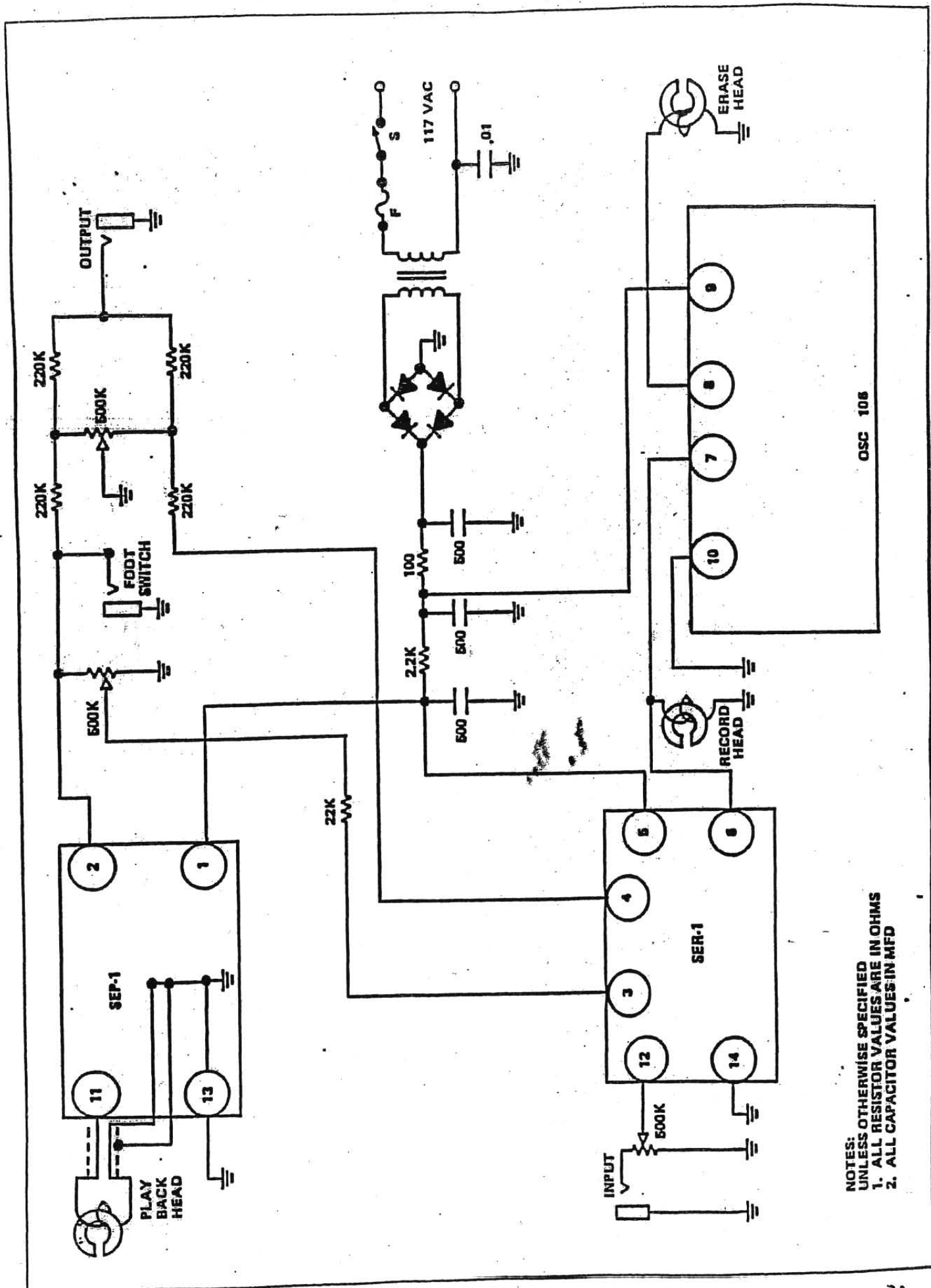

NOTES:
 UNLESS OTHERWISE SPECIFIED
 1. ALL RESISTOR VALUES ARE IN OHMS
 2. ALL CAPACITOR VALUES IN MFD

SIRFKO SE-1 SCHEMATIC DIAGRAM - CIRCUIT BOARD HOOKUP

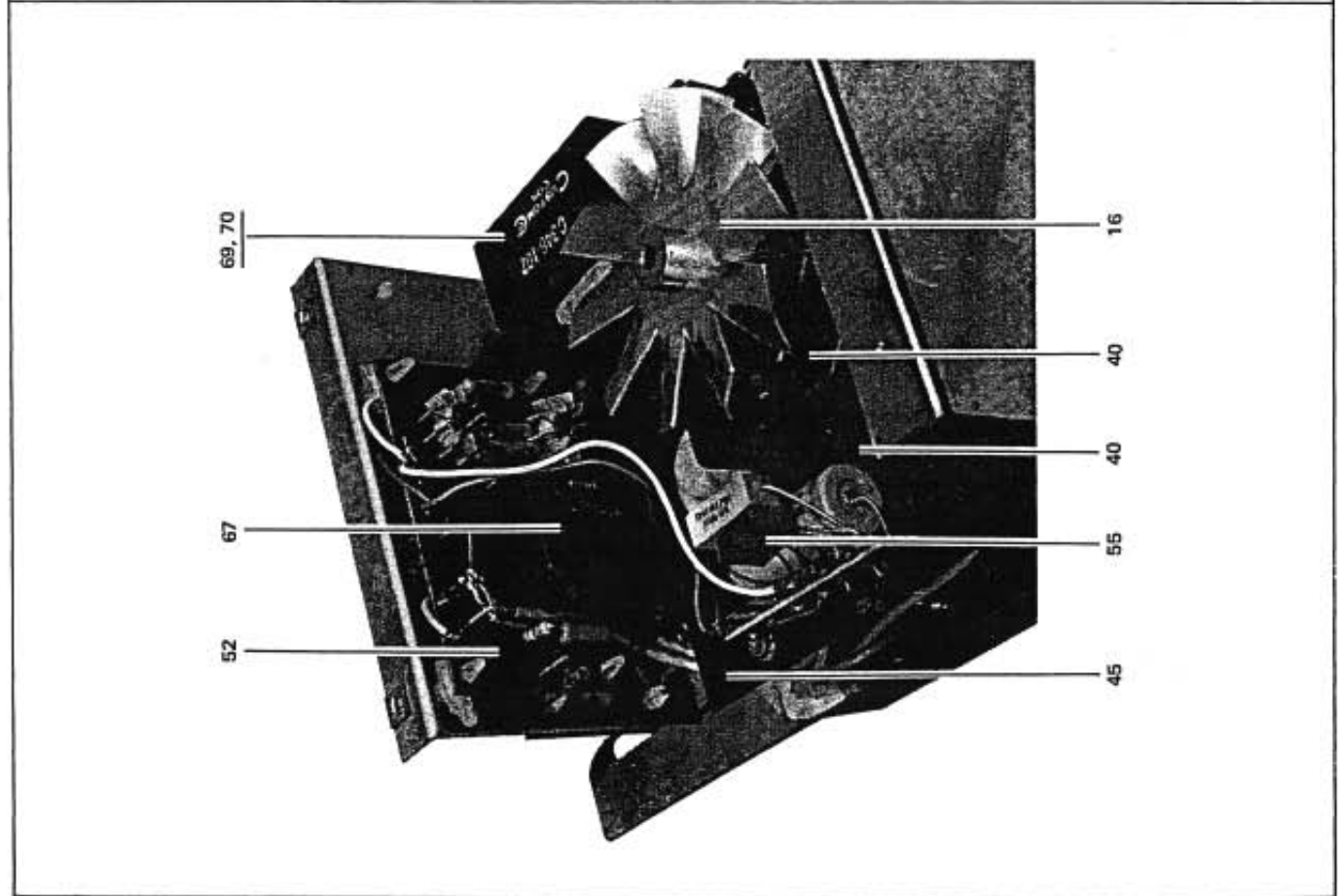
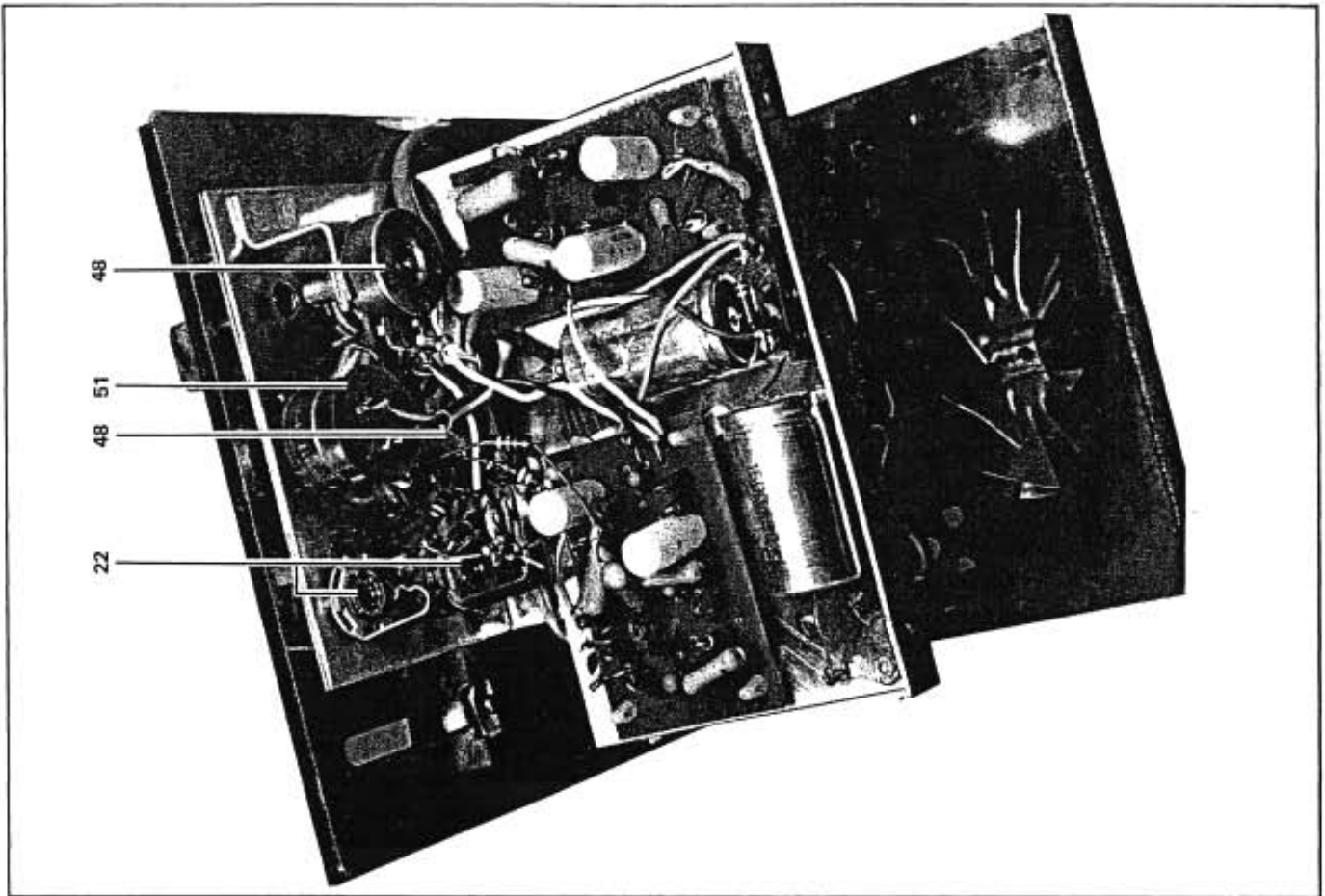

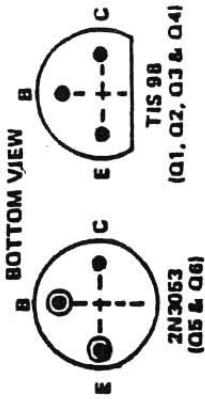
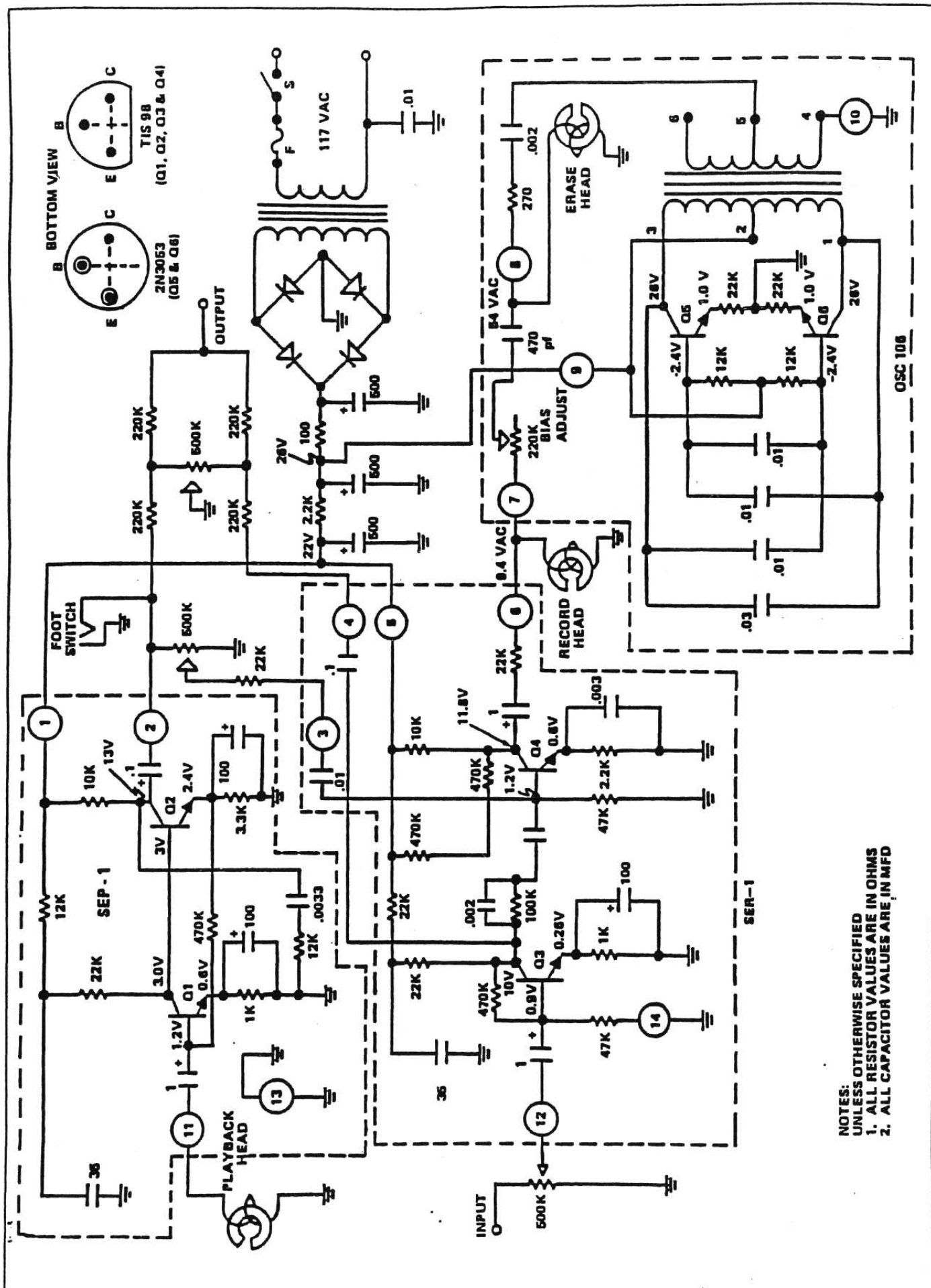

NOTES:
 UNLESS OTHERWISE SPECIFIED
 1. ALL RESISTOR VALUES ARE IN OHMS
 2. ALL CAPACITOR VALUES ARE IN MFD

SIREKO SE-1 SCHEMATIC DIAGRAM

SELECTED REPLACEMENT PARTS LIST

INDEX NO.	PART NUMBER	DESCRIPTION
1	962-043826-001	Bearing, Flywheel
2	964-043827-001	Bearing Cap, Flywheel
3	916-043233-001	Belt, Motor Drive, EP-1, EP-4, Groupmaster
4	916-043233-001	Belt, Motor Drive, Sireko
	961-043767-001	Bracket, Playback Head Mounting
	978-043398-001	Cabinet, EP-3, EP-4
	978-043768-001	Cabinet, Groupmaster
	978-043398-001	Cabinet, Sireko
5	944-043769-001	Capacitor, Var., Bias Trap, 90-400pfd
6	962-043770-001	Carrier, Movable Head, Sireko
7	962-043771-001	Carrier and Guide Post Assembly, Movable Head, EP-1, EP-2
8	962-043771-002	Carrier and Guide Post Assembly, Movable Head, EP-3, EP-4, Groupmaster
9	964-043772-001	Carrier, Tape Cartridge, Sireko
	932-043773-001	Carton Complex, EP-3, EP-4
	932-043774-001	Carton Complex, Sireko
10	956-043775-001	Choke, 10 mhy
11	956-043776-001	Choke, 18 mhy
12	939-043777-001	Circuit Breaker, .75 Ampere Hold
13	952-043778-001	Coil, Bias Oscillator
	964-043779-001	Cover, Tape Cartridge, EP-1, EP-4, Groupmaster
	964-043780-001	Cover, Tape Head, Sireko
	919-043147-001	Diode, 1N914
14	919-043244-001	Diode, Rectifier, EP-1, EP-2
15	919-041255-002	Diode, Zener, 1N4748A
16	962-043781-001	Fan, Echoplex, All Models
17	962-043782-001	Flywheel and Capstan Assembly, All Models
18	921-043156-001	Head, Playback, G1HY2K
19	921-043154-001	Head, Record-Erase, A1HC44R
20	921-043155-001	Head, Record-Erase, A1HC47R

INDEX NO.	PART NUMBER	DESCRIPTION
46	935-043801-001	Plate, Flywheel Thrust Bearing, and Motor Mounting, Old Style
47	935-043801-002	Round Motor Plate, Flywheel Thrust Bearing, and Motor Mounting, New Style
48	910-042043-001	Square Motor
	925-043802-001	Plug, Phone, .250" 2 Conductor
49	925-043802-002	Potentiometer, Control, 500K Audio Taper, with SPST Switch
50	925-043803-001	Potentiometer, Control, 100K Linear Taper
51	925-043804-002	Potentiometer, Control, 500K Linear Taper, with SPST Switch
52	925-043805-001	Potentiometer, Trim, 220K
53	935-043806-001	Pressure Roller Assembly, EP-1, EP-2
54	935-043806-002	Pressure Roller Assembly, EP-3, EP-4, Groupmaster
	928-043808-001	Pulley, Motor Drive, New Style
	928-043807-001	Square Motor Pulley, Motor Drive, Old Style
	928-043809-001	Round Motor
55	919-043149-001	Pulley, Motor Drive, Sireko Rectifier, Bridge, 1 Ampere, 100 PIV
56	903-043810-001	Screw, Knurled Thumb, Tape Cartridge and Tape Cover
57	921-043158-001	Solenoid, Pressure Roller, 115 Volt, For Serial Numbers 12960 and Below
58	921-043158-002	Solenoid, Pressure Roller, 24 Volt, For Serial Numbers 12961 and Above
59	964-043811-001	Spool, Tape Guide
60	975-043822-001	Spring, Pressure Roller Actuator

21	991-043148-001 991-043783-001	Integrated Circuit, LM3900 Integrated Circuit, Voltage Regulator, UA78M24	61	960-043812-001 960-043004-001 960-043813-001	Switch, DPDT, Battery Switch, SPST, Push, Foot Pedal Switch, DPDT, Toggle
22	910-041306-001 910-041306-002	Jack, Phons, .250" 2 Conductor Jack, Phons, .250" 2 Conductor, N.C. Switch	62	935-043253-001 935-043252-001	Tape Cartridge, Sireko Tape Cartridge, 3 Minute, EP-1, EP-4, Groupmaster
23	915-043784-001	Knob, Front Panel, EP-1, EP-2, Sireko, Groupmaster	63	932-043252-002	Tape Cartridge, 4 Minute, EP-1, EP-4, Groupmaster
24	915-043785-001 915-043786-001	Knob, Front Panel, EP-3, EP-4 Knob, Movable Head Carrier	64	961-043814-001 954-043153-001	Track, Movable Head Transformer, Bias Oscillator, T70-T2
25	939-043787-001 939-043788-001	Lamp, Recording, Groupmaster Lamp, Recording, EP-1, EP-2	65	954-043815-001 954-043157-001	Transformer, EP-1, EP-2, 115 Volt Transformer, EP-3, Sireko, Groupmaster, 115 Volt
26	939-043789-001	Lamp, Recording, EP-3, EP-4	66	954-043157-002	Transformer, EP-3, Sireko, Groupmaster, 230 Volt
27	939-041850-002 939-041850-001	L.E.D., Green L.E.D., Red	67	954-043816-001 954-043816-002	Transformer, EP-4, 115 Volt Transformer, EP-4, 230 Volt
28	939-041850-003	L.E.D., Yellow	68	991-041145-001	Transistor, Field Effect, T1S58
29	911-043823-000 962-043790-001	Laver, Pressure Roller Actuator Laver, Tape Cartridge Pressure, Sireko	69	991-043150-001 991-041160-001	Transistor, MPS8098 Transistor, T1S98
30	993-043791-001 993-043791-002	Manual, Owners, EP-3 Manual, Owners, EP-4	70	991-043817-001 991-043146-001	Transistor, 2N1711 Transistor, 2N3053
31	993-043791-003 993-043019-001	Manual, Owners, Sireko Manual, Owners and Service, All Models	71	990-043818-001 990-043818-001	Vacuum Tube, 6C4 Vacuum Tube, 6EU7
32	935-043792-001 935-043793-001	Meter, VU, Groupmaster Meter, VU, EP4	72	990-043819-001 904-043820-001	Washer, Rubber, Movable Head Carrier
33	921-043797-001 921-043797-002	Motor, New Style, Square, 115 Volt Motor, New Style, Square, 230 Volt	73	904-043821-001	Washer, Steel, Movable Head Carrier
34	921-043796-001 921-043796-002	Motor, Old Style, Round, 115 Volt Motor, Old Style, Round, 230 Volt	74		
35	916-043794-001 916-043795-001	Mount, New Style Square Motor Mount, Old Style Round Motor	75		
36	976-043798-001 913-043824-001	Pad, Tape Pressure Panel, Front, EP-3	76		
37	913-043825-001 935-043789-001	Panel, Front, EP-4 Pedal, Foot Assembly			
38	935-043800-001	Plate, Flywheel Thrust Bearing, end Motor Mounting, Sireko			

35	935-043792-001 935-043793-001	Meter, VU, Groupmaster Meter, VU, EP4	73	904-043821-001	Washer, Steel, Movable Head Carrier
36	921-043797-001 921-043797-002	Motor, New Style, Square, 115 Volt Motor, New Style, Square, 230 Volt	74		
37	921-043796-001 921-043796-002	Motor, Old Style, Round, 115 Volt Motor, Old Style, Round, 230 Volt	75		
38	916-043794-001 916-043795-001	Mount, New Style Square Motor Mount, Old Style Round Motor	76		
39	976-043798-001 913-043824-001	Pad, Tape Pressure Panel, Front, EP-3			
40	913-043825-001 935-043789-001	Panel, Front, EP-4 Pedal, Foot Assembly			
41	935-043800-001	Plate, Flywheel Thrust Bearing, end Motor Mounting, Sireko			

**DIRECTIONS FOR REPLACEMENT OF NEW CARTRIDGE
AND INSTALLATION OF TENSION PAD**

1. **REMOVING OF OLD CARTRIDGE.** Remove Cover Plate. Remove Guitar plug from Input Jack. Slide Record/Erase head to center. Remove tape from around Position "E" after bending back Lug.

Remove knurled thumb screws at position "A". Remove old cartridge.
NOTE: This is a good time to clean tape heads, roller and capstan. For cleaning use cotton cue stick and alcohol or lighter fluid.

2. **REMOVING NEW TAPE CARTRIDGE FROM CARTON.** Withdraw cartridge from carton at end marked "open". Take off scotch tape which holds the cartridge to cardboard support. Do not crease tape.

The Diagram printed below illustrates correct positioning of tape when using TENSION PAD enclosed with cartridge. Improper positioning of tape or pad will cause unsatisfactory performance.

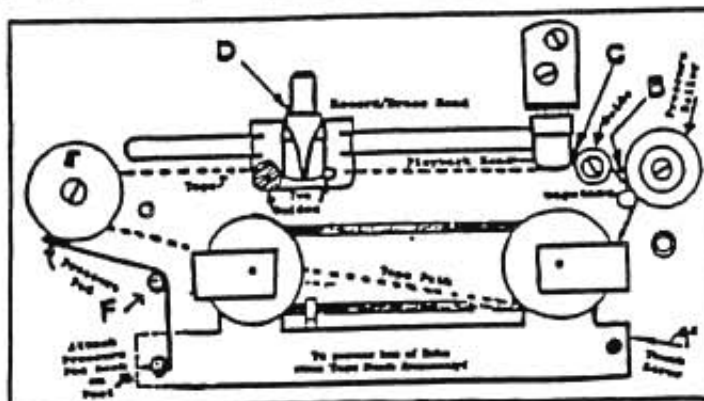

3. **POSITIONING NEW TAPE CARTRIDGE.** After cartridge is screwed down place tape gently between Capstan and Pressure Roller...Position "B". Continue placement of tape to position "C"...between guide and Playback head. The next position locates tape between TWO GUIDES and Record/Erase head...position "D". Now pull on tape to obtain about four inches of slack so that tape can be pulled around bearing post...position "E". Notice on diagram that tape path is in front of post "F".
4. **INSTALLATION OF TENSION PAD.** Place Felt end of Tension Pad against and between concave/convex washers at position "E". Curve spring around post "F" and attach hooked end of Spring under cartridge post "A" to this post.
5. **TAPE "RUN-IN".** The Tape is now positioned but will require a careful "run-in" to adjust loop lengths. By hand manipulate the Input Jack Lever. Do this slowly...off....on....alternately, until you are satisfied that the tape is running smoothly.
6. Replace Vender Cover and tighten thumb screws.

ECHOPLEX

Another Quality Product from Norlin

MOOG MUSIC INC.

2500 Walden Avenue, Buffalo, New York 14225

NORLIN MUSIC

7373 N. Cicero Avenue, Lincolnwood, Illinois 60466

NORLIN MUSIC INSTRUMENTS LIMITED

51 Nantucket Blvd., Scarborough, Ontario, Canada M1P 2N6

NORLIN MUSIC LIMITED

114 Charing Cross Road, London, England

NORLIN MUSIC SERVICES B.V.

Waalhaven Zuidzijde 48, 3088 H. J., Rotterdam, The Netherlands

Manufactured for Norlin by

MARKET ELECTRONICS

38367 Apollo Parkway, Willoughby, Ohio 44094