

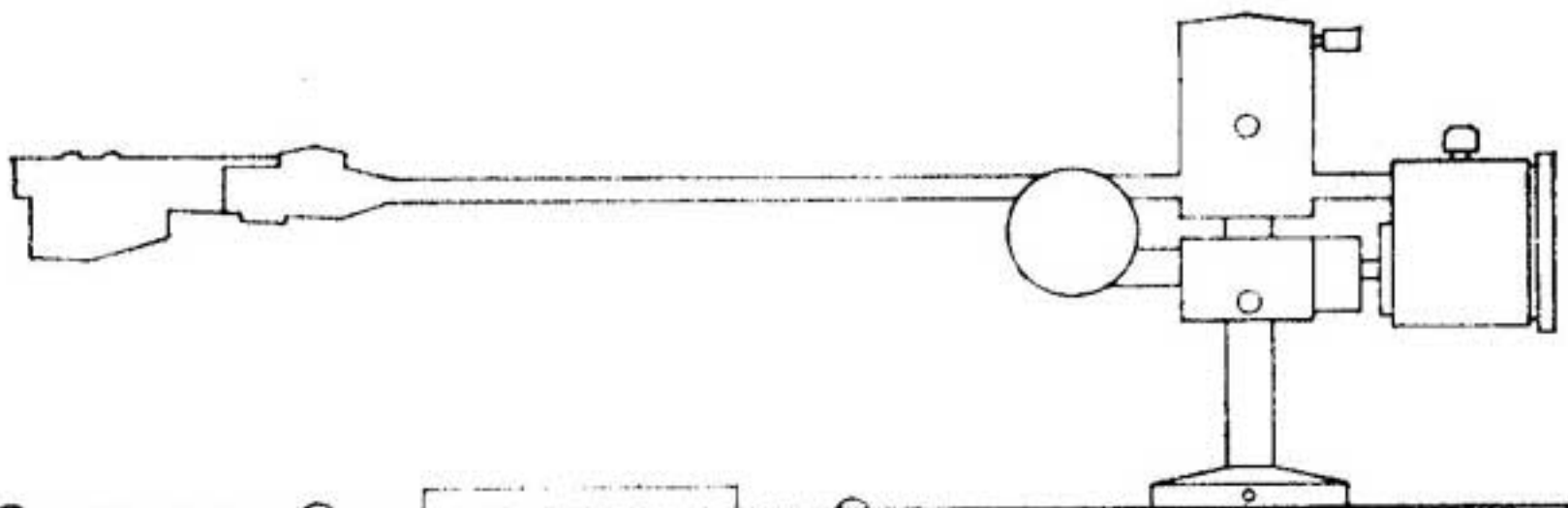

J A MICHEL
ENGINEERING
LIMITED



FLUID ARM

Mounting and Setting Instructions

Fluid Arm

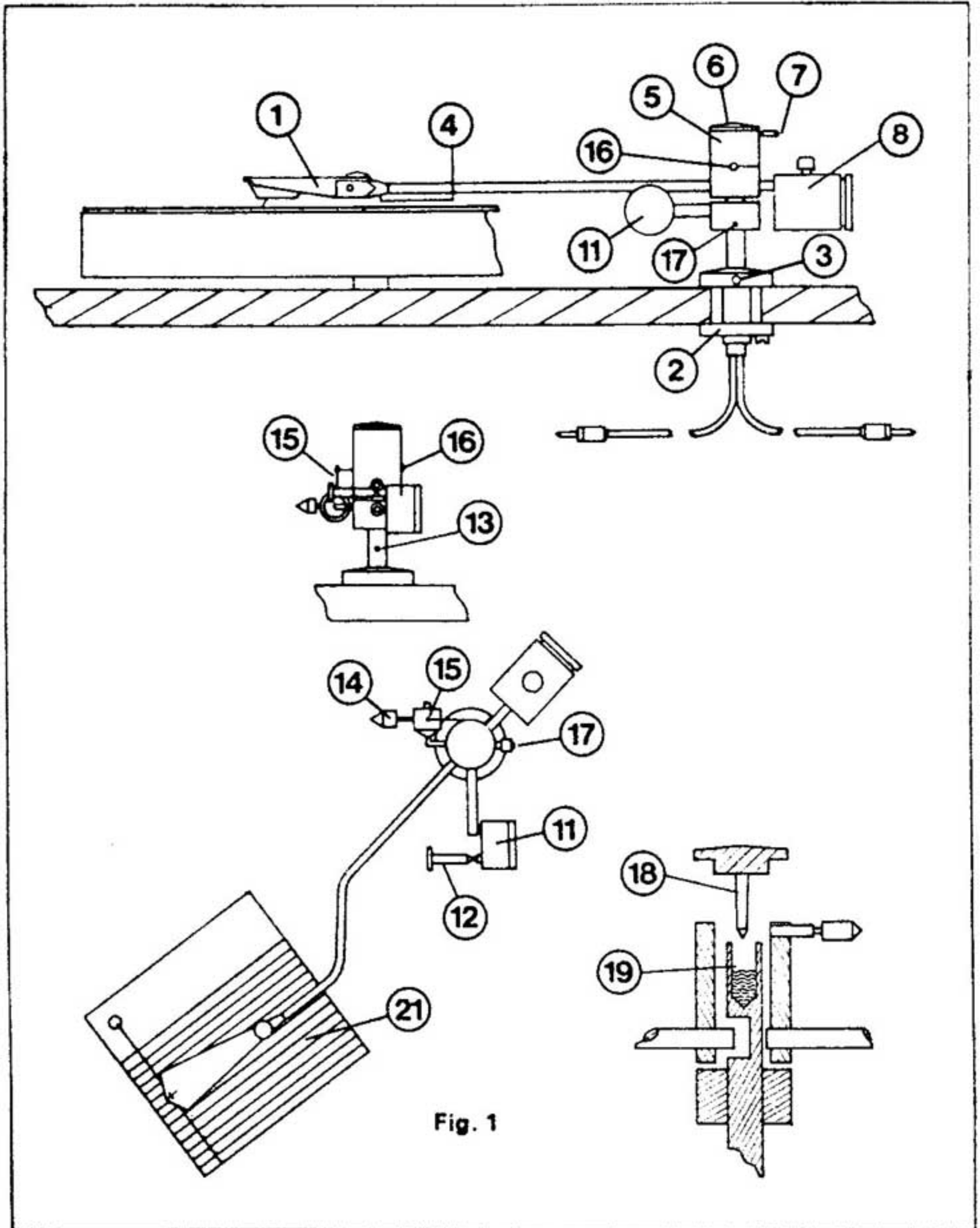

Fig. 1

Fluid Arm—mounting and setting instructions

The Fluid Arm can be mounted by cutting a 1 in. (25 mm) diameter hole, in any suitable position on a $8\frac{1}{2}$ in. (216 mm) radius from the centre of the turntable platter. An allowance of $1\frac{1}{2}$ in. (37 mm) for counterweight overhang must be made to ensure clearance to the sides and rear of turntable plinth and cover.

Fluid Arm—setting-up instructions

- 1** Releasing the retaining nut, the headshell should be removed from the arm holding cone, fig. 1(4), carefully in one hand, using a side-to-side and easing movement with other hand. Extreme care must be exercised as damage to the internal wiring could result if force is used. Remove all transit rubber bands.
- 2** Release thumbscrew, fig. 1(7), and remove helmet cap and pivot assembly. From the small tube supplied, fill the well of the support tube to approximately halfway, fig. 1(19). Refit cap and pivot securely.
- 3** The bias assembly is positioned by using cotton thread tied to the split pin and following a path around the back of the helmet to the small slotted screw. The angle of the bias weight should be set as in fig. 1(15) with the arm in a parked position.
- 4** Connect the cartridge to the left and right leads, which are marked on the underneath of the headshell, using the two red leads for signals and the two green for earthing. The cartridge can now be mounted, into the headshell, using the second pair of holes as viewed from the front. Replace headshell into arm and secure retainer.
- 5** Fit the eccentric counterweight with the knurled adjuster facing to rear, and lightly tighten the thumbscrew to hold in place. Turn adjuster fully anti-clockwise.
- 6** The thumbscrew should now be released and the counterweight moved along its shaft until the arm is in a state of balance. Whilst moving the counterweight, it can be rotated in the desired direction to allow the helmet to remain vertical while playing.
- 7** The correct tracking weight can now be achieved by rotating the adjuster clockwise until stylus barely comes to rest on record. Now add exact cartridge tracking weight using coloured spots, each representing $\frac{1}{4}$ gramme.
- 8** Place the template over the centre spindle of turntable platter, and, after slackening thumbscrew, fig. 1(17), move arm across and place stylus tip on point indicated. The lines of the template

and the headshell must run parallel to each other to ensure minimum tracking error. To correct any misalignment, slacken, with the aid of a suitable piece of $\frac{1}{8}$ in. (3 mm) rod or small screwdriver, the lower base nut using one of the holes for this purpose. The arm can now be moved until the correct alignment is achieved. Relock the arm, ensuring that the centre dot mark, fig. 1(13), on the support tube is facing the front of deck. At this stage the arm height can be set, using the lock screw, fig. 1(3), to ensure that the arm tube runs parallel to record, when in the playing position.

- 9** Should the need arise, there is provision to make lateral adjustments to the headshell assembly. The small grub screw, fig. 1(4), underneath the aluminium cone can be slackened and the assembly moved until the stylus plays in an upright position. This adjustment should not be made unless necessary, i.e. helmet and stylus must both be in vertical modes.
- 10** Correct bias compensation can be set, by moving the weight in or out of the roller, until there is a stationary action of the arm when placed on a blank disc (no grooves). Bias compensator is provisionally set for nominal working.
- 11** Re-check all the above instructions and make adjustments if necessary.
- 12** Connect phono plugs to amplifier—red plug to right and black to left.

Using the Fluid Arm

The whole lifting and cueing assembly, swings around the support tube, and a degree of damping is provided by applying the required tension to the thumbscrew, fig. 1(17).

With the lift/lowering device in its raised position, swing the whole assembly around, with the arm tube in its cradle groove, until the selected band of the disc is reached. Turn the lift/lowering device in an anticlockwise direction until a point is reached when the arm will lower hydraulically, or alternatively, can be lowered manually. Once the stylus is on the disc, the cueing assembly should be returned to a frontal position to maintain the correct bias setting. To return arm to its parked position, simply reverse the above procedure, remembering to have the lift/lowering device in its lowered state. To obtain a clean and silent lift from the disc it is advisable to use the parallel and not grooved section of the lifter.

In the interests of continually improving specifications we reserve the right to change the design or details without prior notice.