

ECO#	REV:	DESCRIPTION	REV. BY:	APP. BY:	DATE
------	------	-------------	----------	----------	------

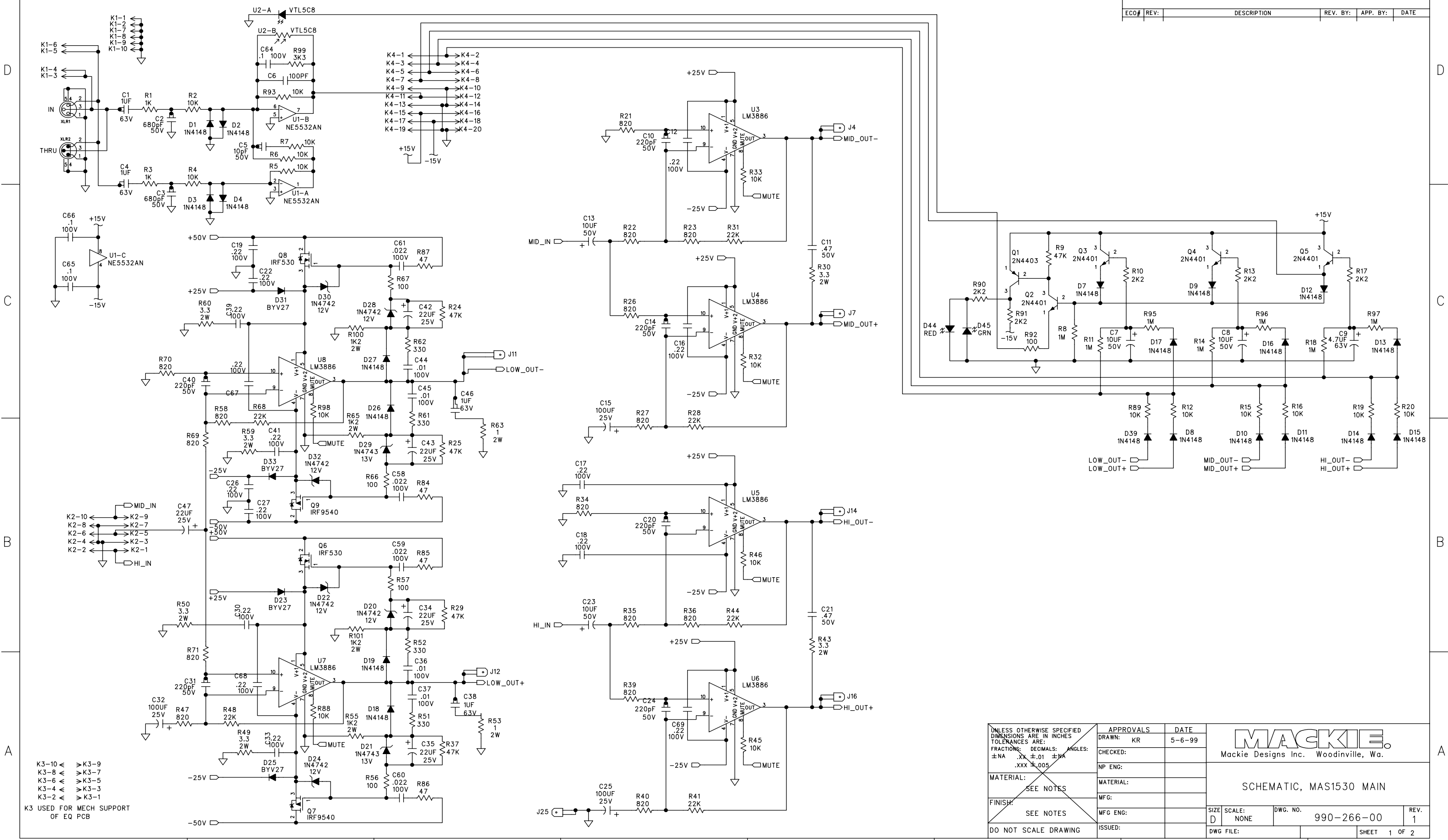

K3-10 <-> K3-9
 K3-8 <-> K3-7
 K3-6 <-> K3-5
 K3-4 <-> K3-3
 K3-2 <-> K3-1
 K3 USED FOR MECH SUPPORT OF EQ PCB

UNLESS OTHERWISE SPECIFIED DIMENSIONS ARE IN INCHES TOLERANCES ARE: FRACTIONS: DECIMALS: ANGLES: ±NA .XX ±.01 ±MA .XXX ±.005	APPROVALS	DATE
	DRAWN: KR	5-6-99
	CHECKED:	
	NP ENG:	
MATERIAL:	MATERIAL:	
SEE NOTES	MFG:	
FINISH:	MFG ENG:	
DO NOT SCALE DRAWING	ISSUED:	

MACKIE
 Mackie Designs Inc. Woodinville, Wa.

SCHMATIC, MAS1530 MAIN

SIZE: D	SCALE: NONE	DWG. NO. 990-266-00	REV. 1
DWG FILE:		SHEET 1 OF 2	

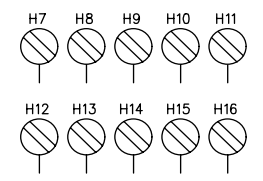
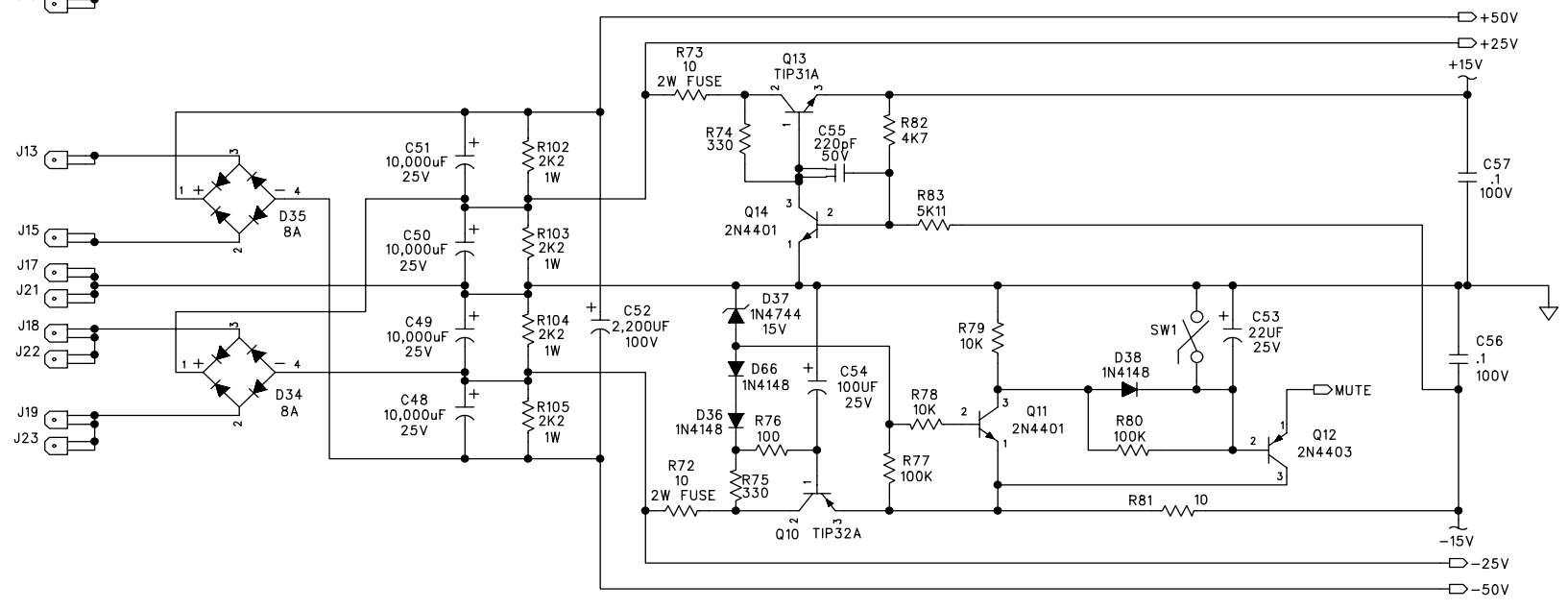
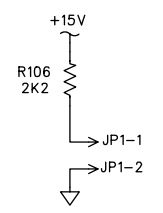
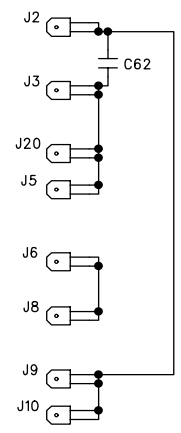
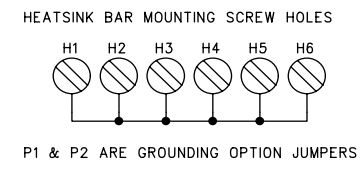

450-266-00
PCB, MAS1530 MAIN

UNLESS OTHERWISE SPECIFIED DIMENSIONS ARE IN INCHES TOLERANCES ARE: FRACTIONS: DECIMALS: ANGLES: ±NA .XX ±.01 ±MA .XXX ±.005	APPROVALS	DATE	 Mackie Designs Inc. Woodinville, Wa.
	DRAWN:		
	CHECKED:		
	NP ENG:		
MATERIAL:	MATERIAL:		SCHEMATIC, MAS1530 MAIN SIZE: D SCALE: NONE DWG. NO. 990-266-00 REV. 1 DWG FILE: SHEET 2 OF 2
SEE NOTES	MFG:		
FINISH:	MFG ENG:		
DO NOT SCALE DRAWING	ISSUED:		

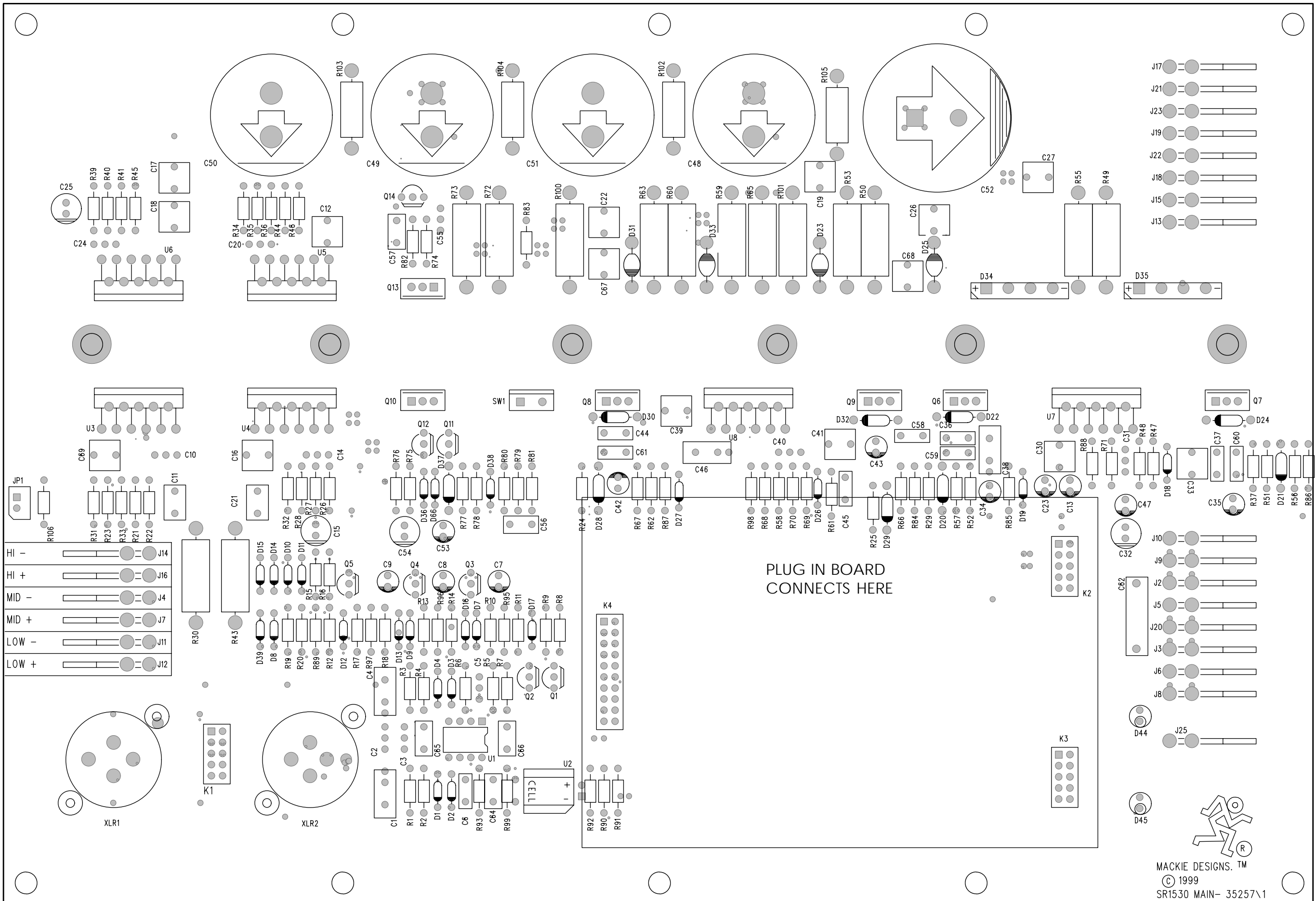

MACKIE DESIGNS.™
 © 1999
 SR1530 MAIN- 35257\1

TOP OF BOARD

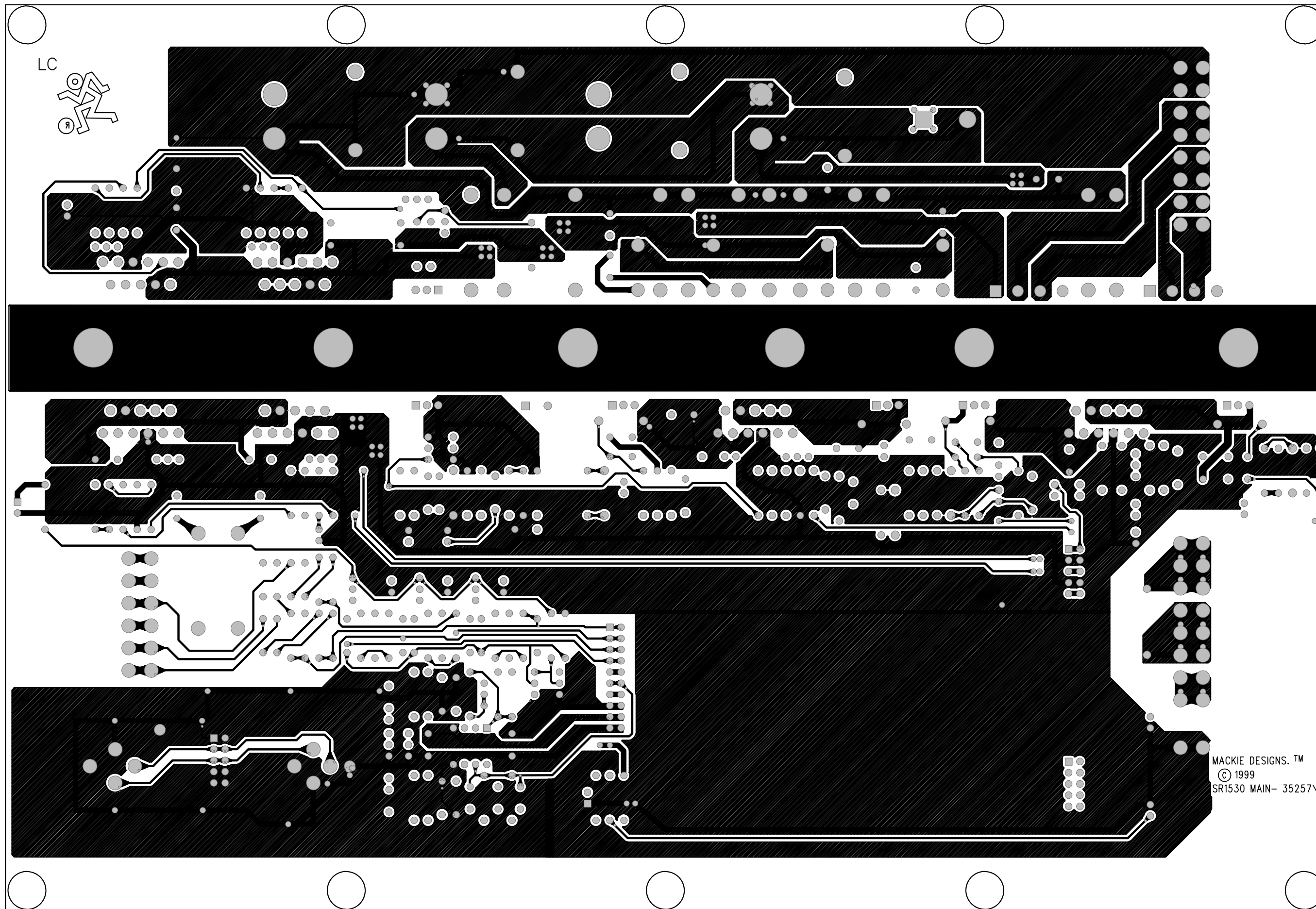

MACKIE DESIGNS.™
© 1999
SR1530 MAIN- 35257\1

BOTTOM OF BOARD

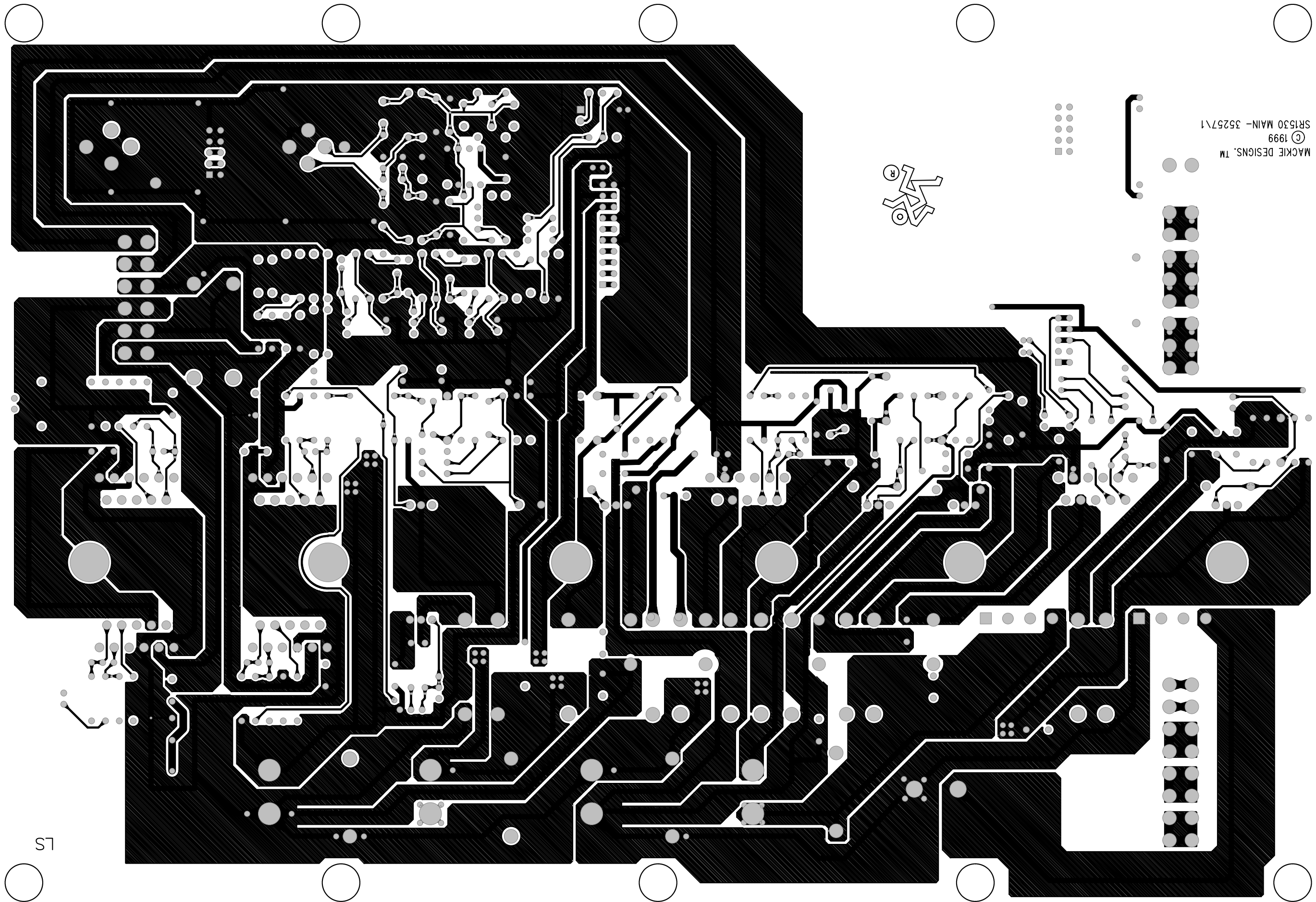

SR1530 MAIN - 35257\1
© 1999
MACKIE DESIGNS, TM

R

S1

D
C
B
A

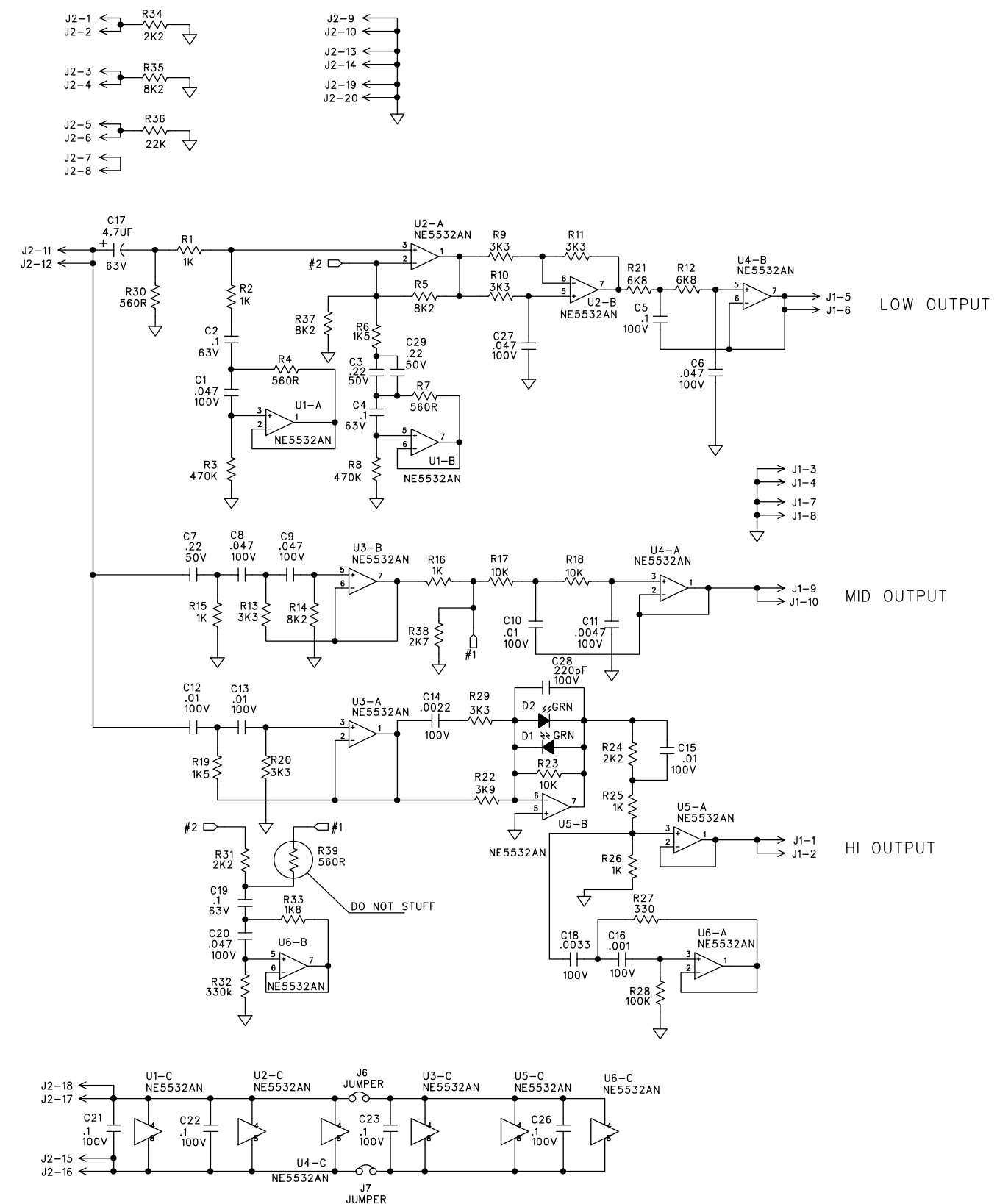

J3-1 → J3-6
 J3-2 → J3-7
 J3-3 → J3-8
 J3-4 → J3-9
 J3-5 → J3-10

J3 USED FOR MECH. SUPPORT OF EQ PCB

UNLESS OTHERWISE SPECIFIED DIMENSIONS ARE IN INCHES TOLERANCES ARE: FRACTIONS: ±.01 ±.005 DECIMALS: ±.01 ±.005 MATERIAL: SEE NOTES FINISH: SEE NOTES DO NOT SCALE DRAWING	APPROVALS	DATE	 Mackie Designs Inc. Woodinville, Wa.	
	DRAWN: STOLZ	28/10/99		
	MATERIAL:	MATERIAL:	Control board MAS1530	
	FINISH:	MFG:		
	DO NOT SCALE DRAWING	ISSUED: STOLZ	3/1/00	SIZE: D SCALE: NONE DWG. NO.: MN 044 503 DWG FILE: MN 044 503.sch
				REV. 1 SHEET 1 OF 1

Bottom of board (copper pour layer is shown by dotted lines)

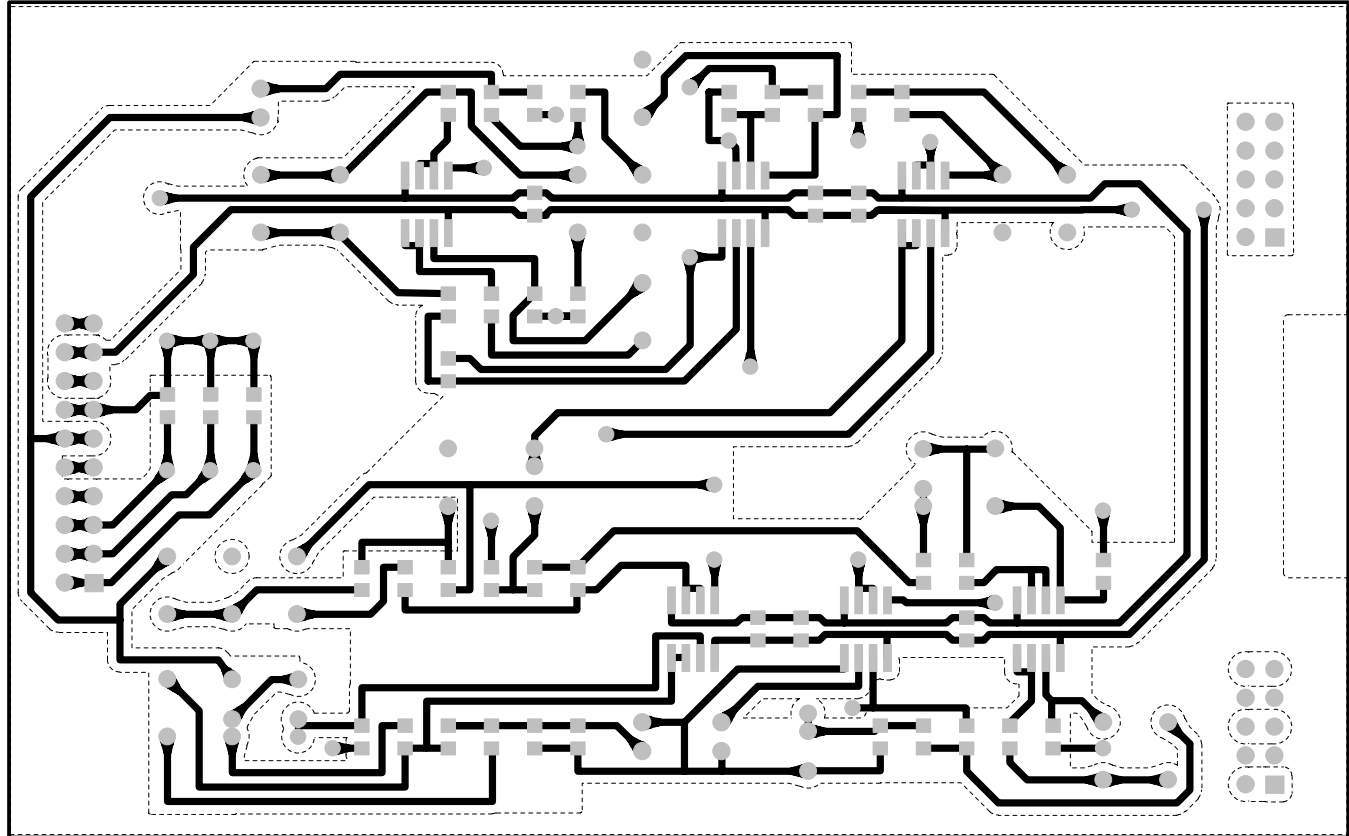
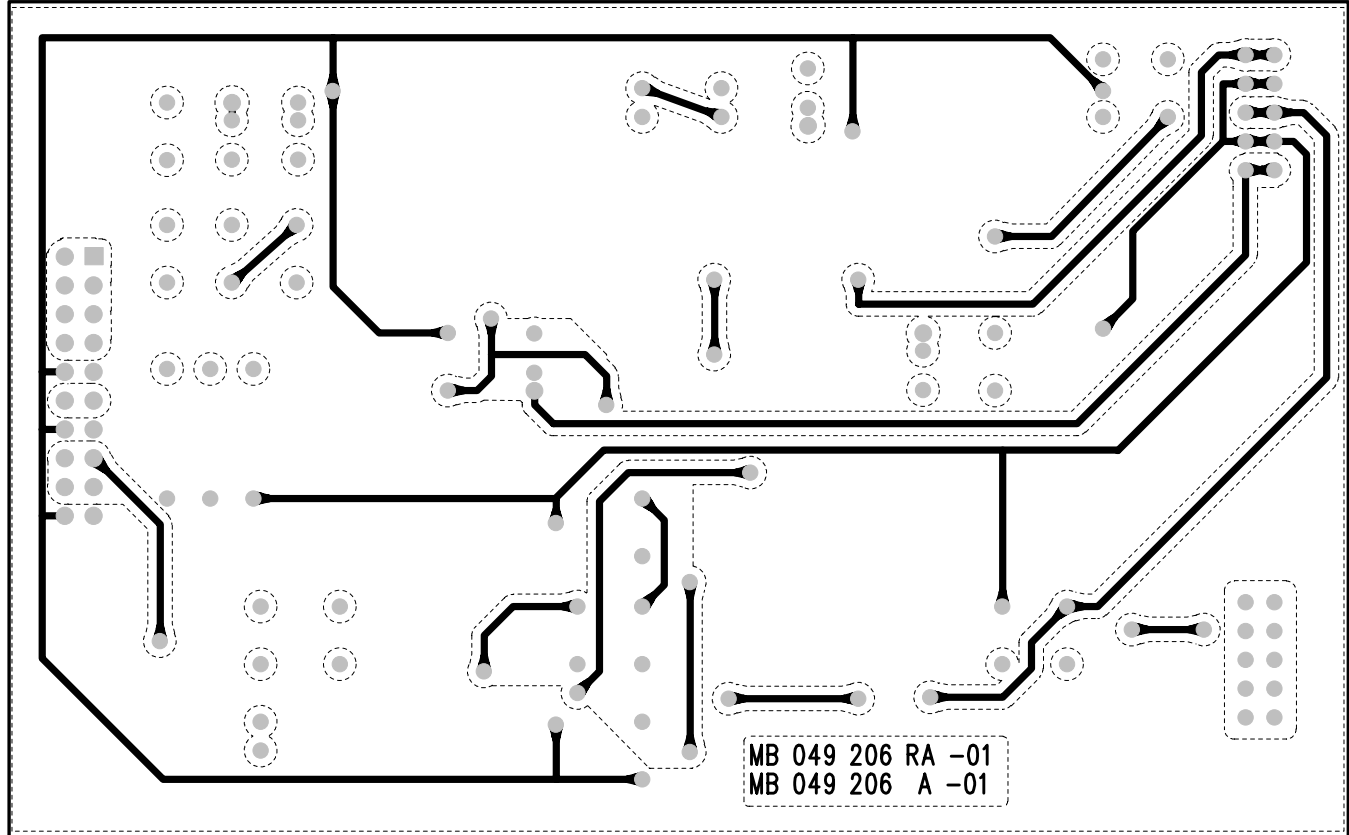

Top of board (copper pour layer is shown by dotted lines)

Top of board (note that connector J3 is only used to help secure this board to the main board).

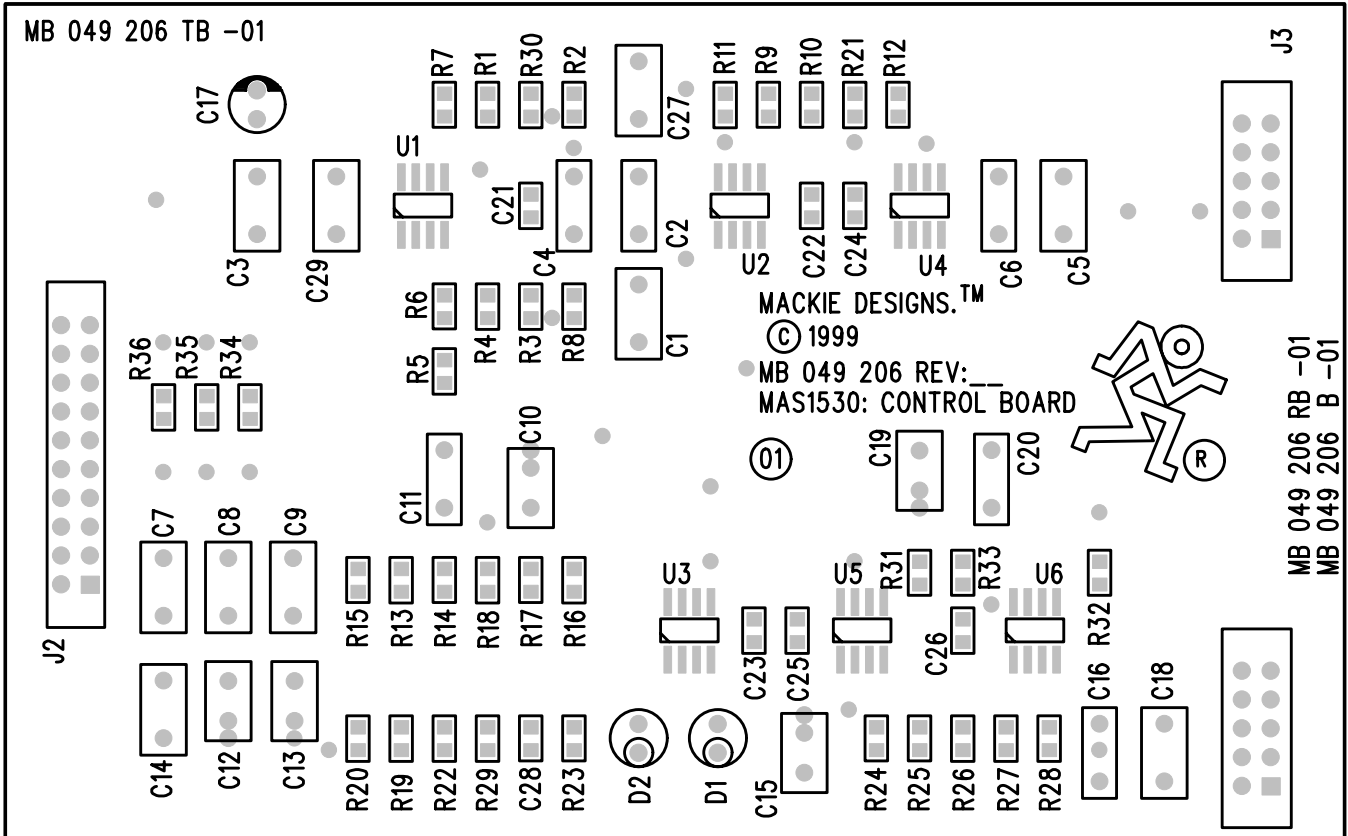

This is the first board and it has through-board holes and components, unlike the surface mount board shown on the previous page.

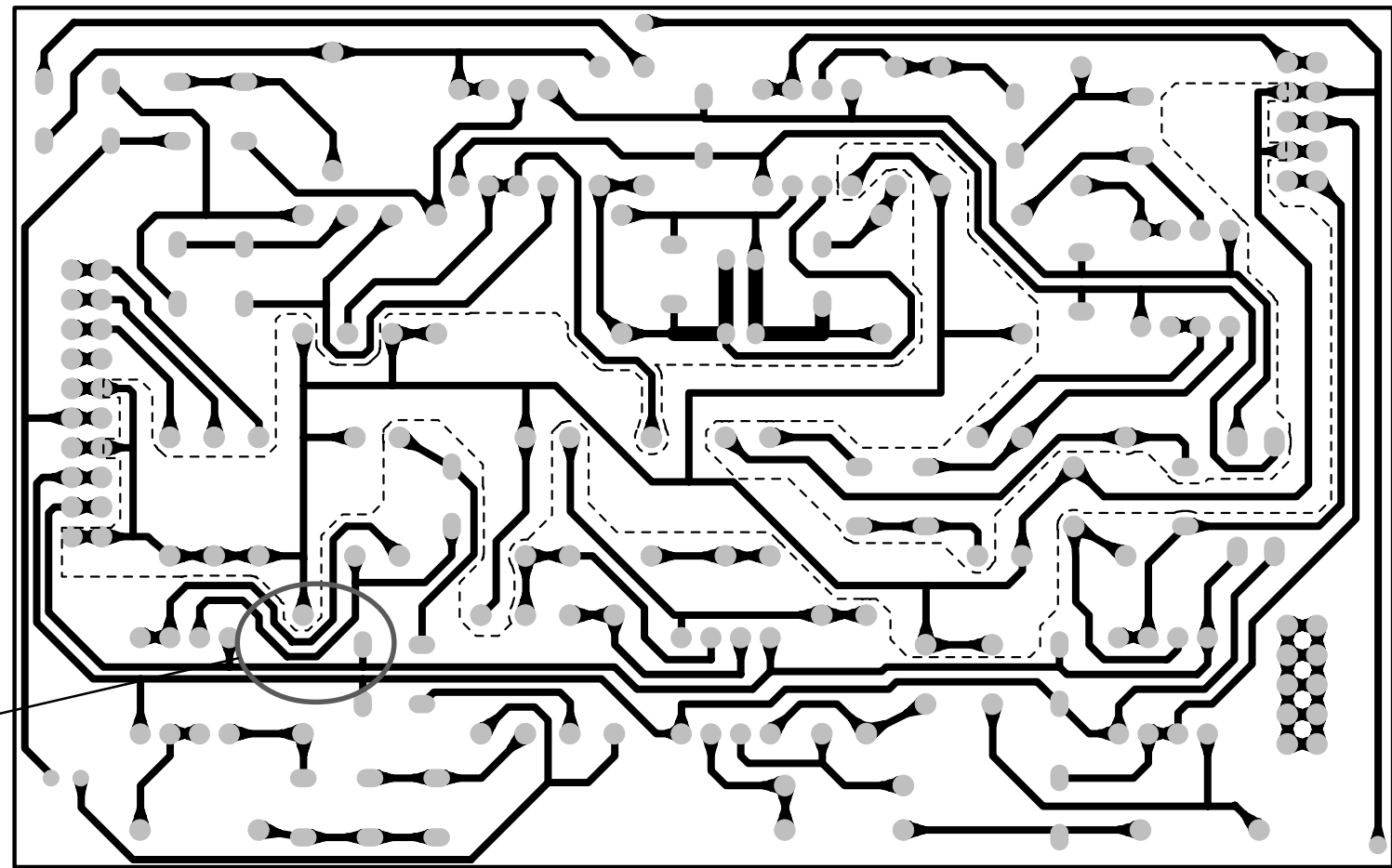

Carefully use a sharp blade to make sure there are no etching shorts in this region, where the traces are very close.

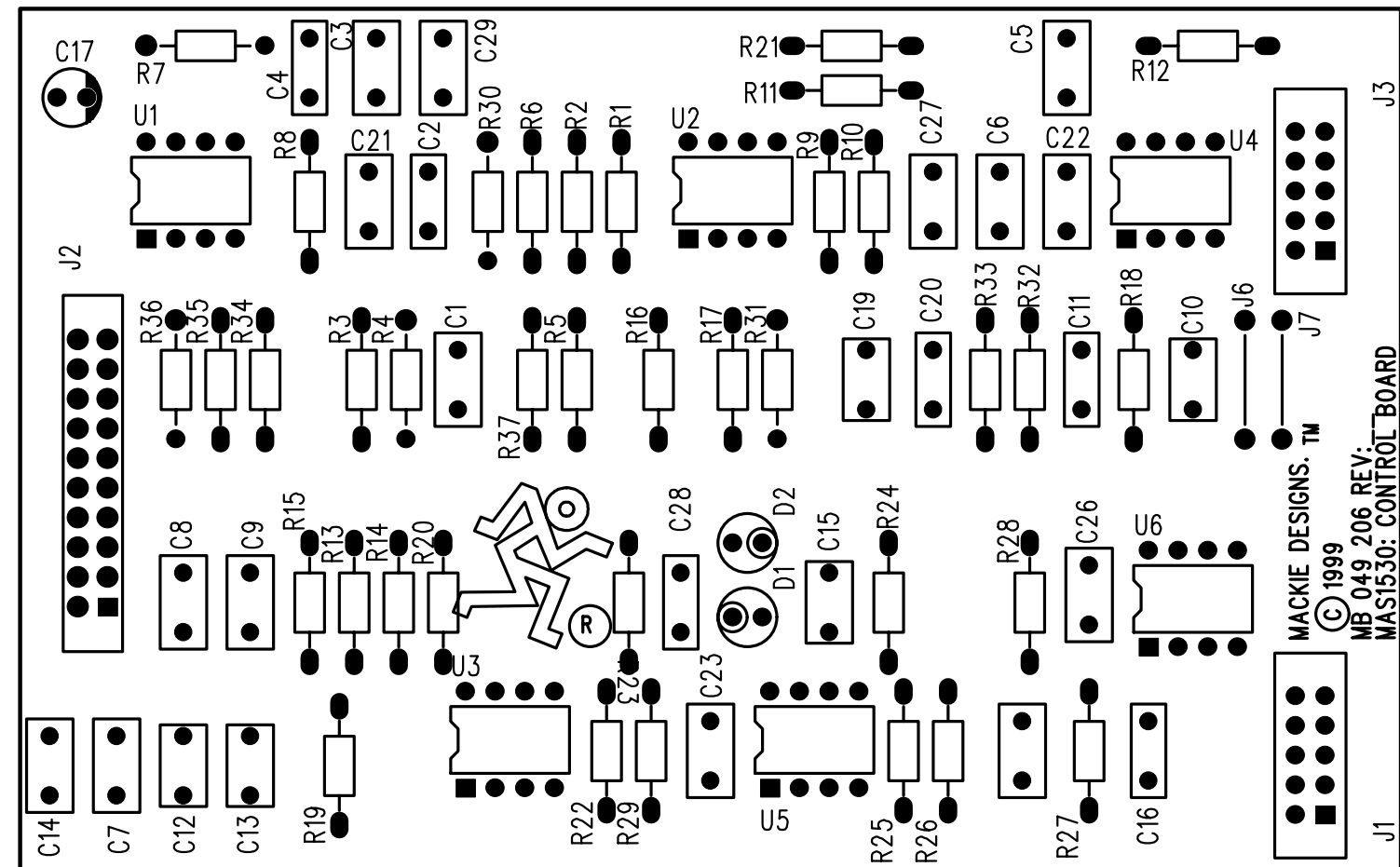

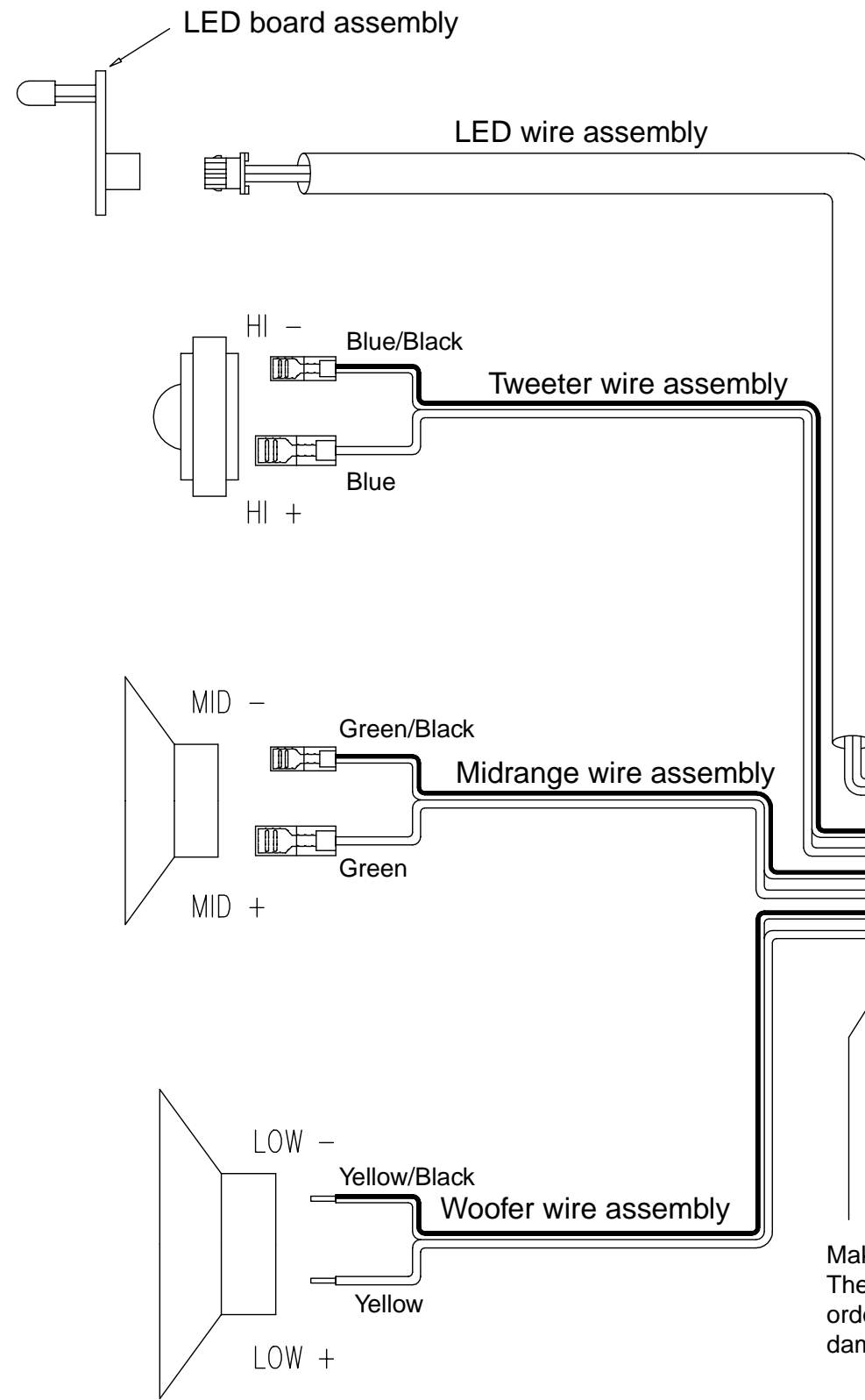

Top (component side) of board

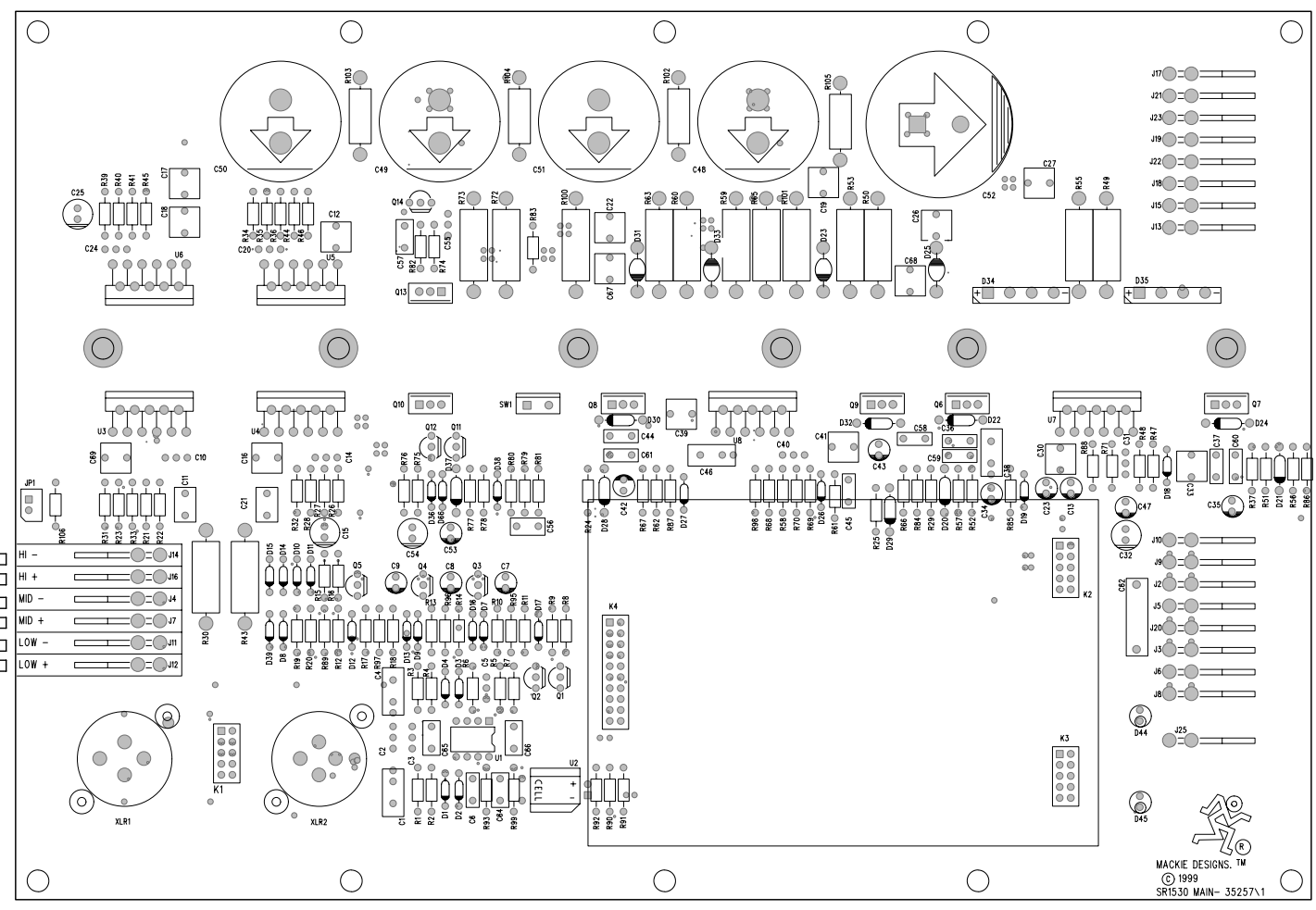

Make sure all connections are as shown. The colored wires must be in the correct order or the transducers will be damaged or out of phase.

