

100VAC:9A
 120VAC:7A
 240VAC:3.5A

RISK OF FIRE!
 REPLACE WITH
 FUSE AS MARKED

SRS1500:
 AC INPUT
 055-271-00 REV:___

MACKIE DESIGNS.™ © 2000

FUSE VALUE CHART

MAINS	F1
100VAC	9A SB
120VAC	7A SB
240VAC	3.5A SB

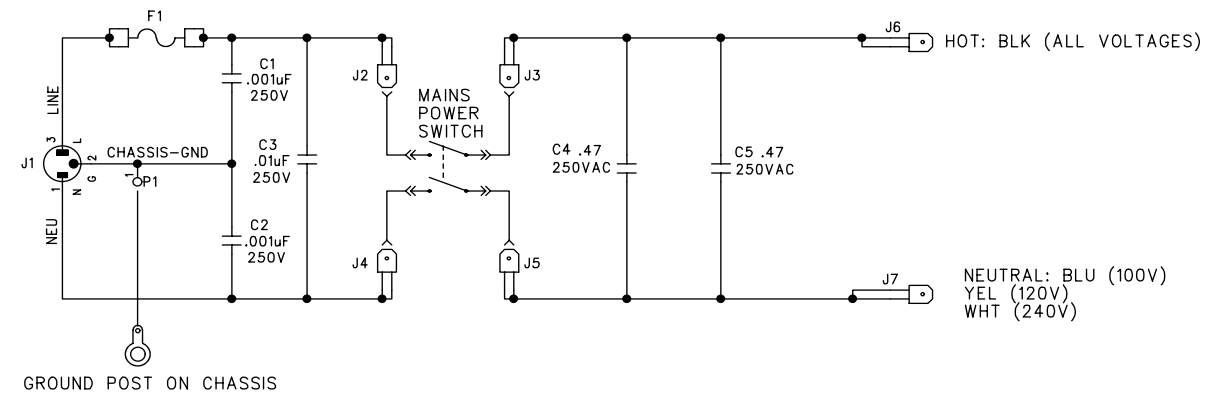

APPROVALS		DATE
DRAWN:	KR	6-10-99
CHECKED:		
NP ENG:		
MATERIAL:		
MFG:		
MFG ENG:		
ISSUED:		

 Mackie Designs Inc. Woodinville, Wa.		SCHEMATIC, SRS1500: AC INPUT	
		SIZE: D	SCALE: NONE
DWG. NO.	990-271-00	REV.	A
DWG. FILE:		SHEET	1 OF 1

D

C

B

A

D

C

B

A

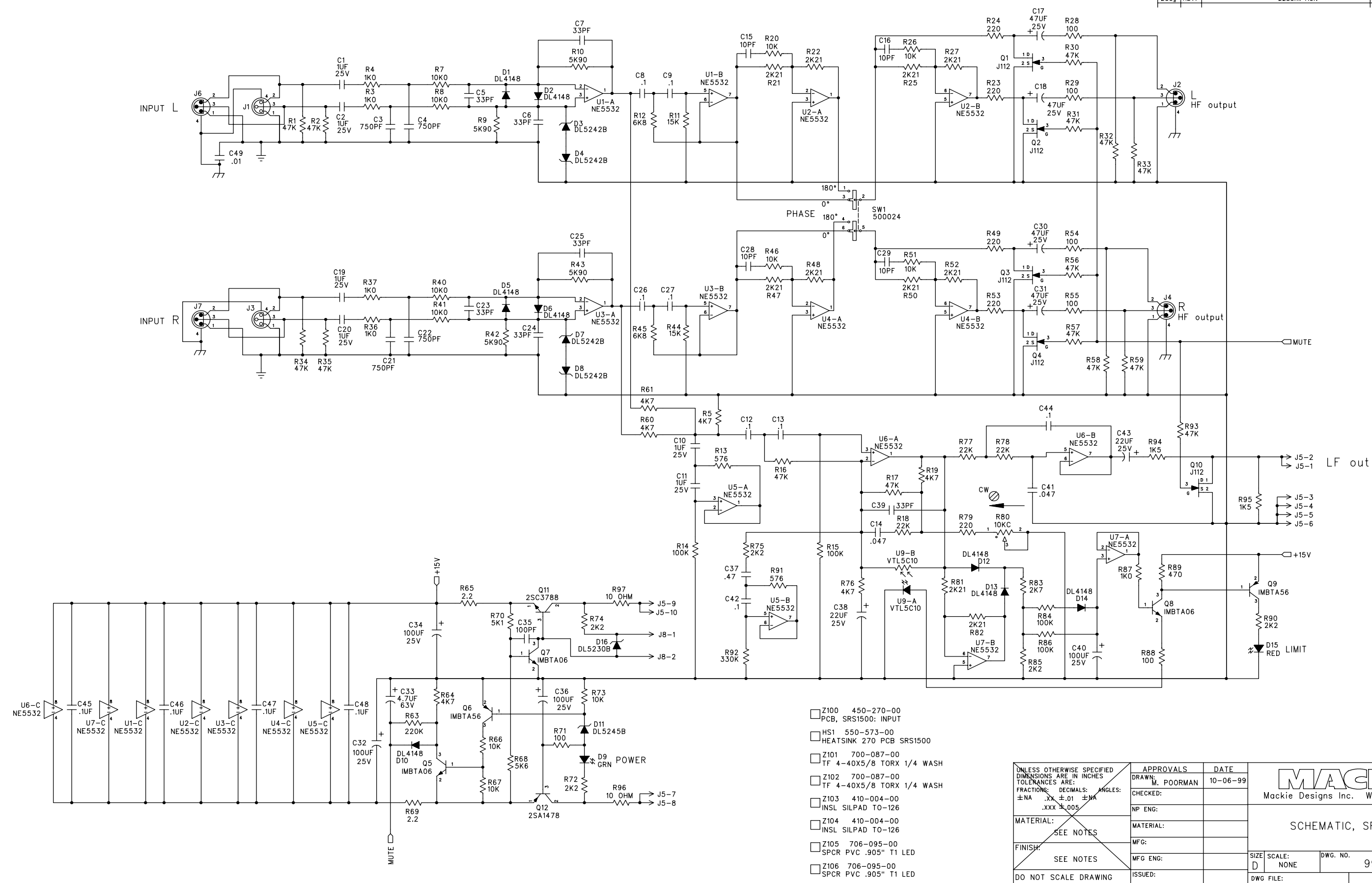

- Z100 450-270-00 PCB, SRS1500: INPUT
- HS1 550-573-00 HEATSINK 270 PCB SRS1500
- Z101 700-087-00 TF 4-40X5/8 TORX 1/4 WASH
- Z102 700-087-00 TF 4-40X5/8 TORX 1/4 WASH
- Z103 410-004-00 INSL SILPAD TO-126
- Z104 410-004-00 INSL SILPAD TO-126
- Z105 706-095-00 SPCR PVC .905" T1 LED
- Z106 706-095-00 SPCR PVC .905" T1 LED

UNLESS OTHERWISE SPECIFIED DIMENSIONS ARE IN INCHES TOLERANCES ARE: FRACTIONS: DECIMALS: ANGLES: ±NA .XX ±.01 ±MA .XXX ±.005	APPROVALS	DATE
	DRAWN: M. POORMAN	10-06-99
	CHECKED:	
	NP ENG:	
MATERIAL:	MATERIAL:	
SEE NOTES	MFG:	
FINISH:	MFG ENG:	
SEE NOTES	ISSUED:	
DO NOT SCALE DRAWING		



Mackie Designs Inc. Woodinville, Wa.

SCHMATIC, SRS1500: INPUT

SIZE: D	SCALE: NONE	DWG. NO. 990-270-00	REV. A
DWG FILE:		SHEET 1 OF 1	

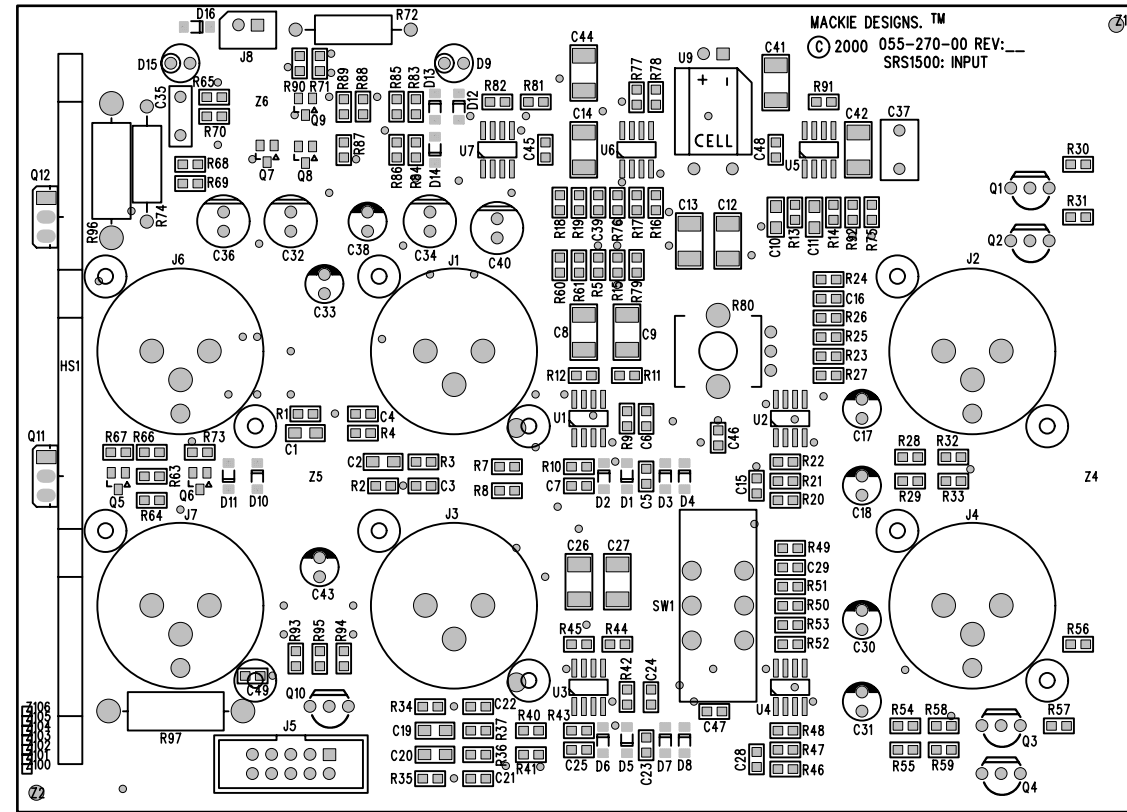

Bottom of board

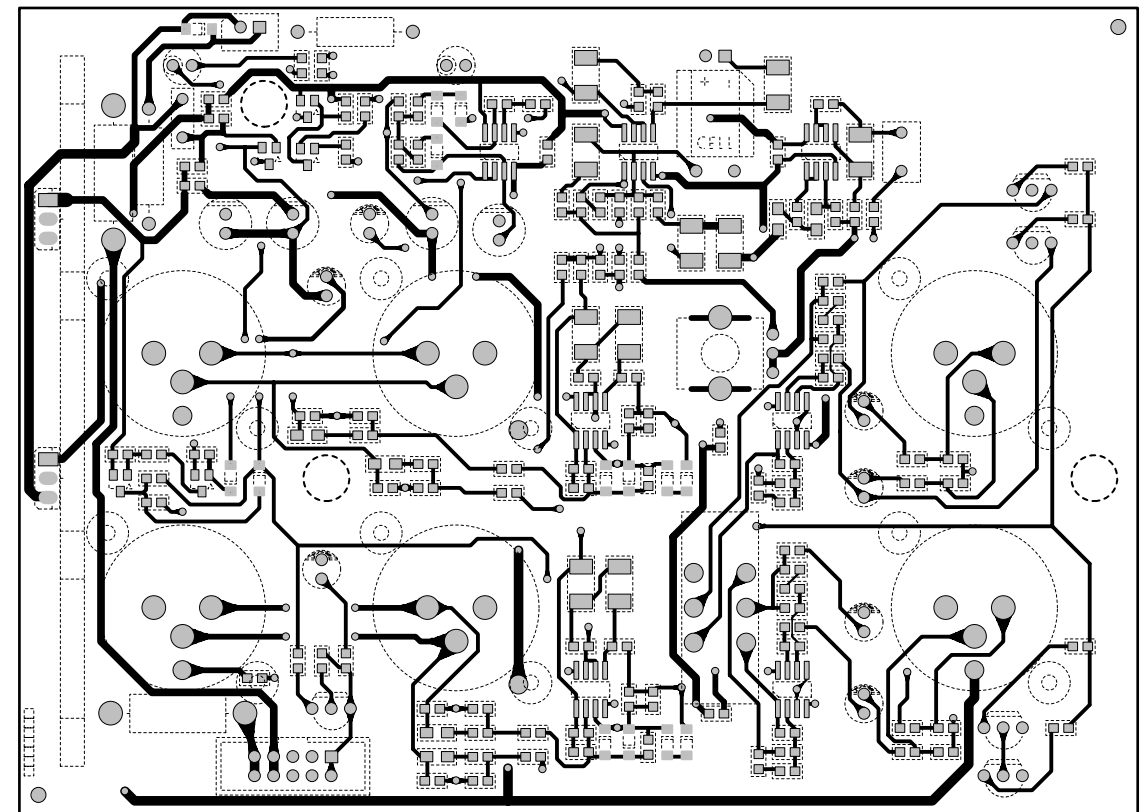
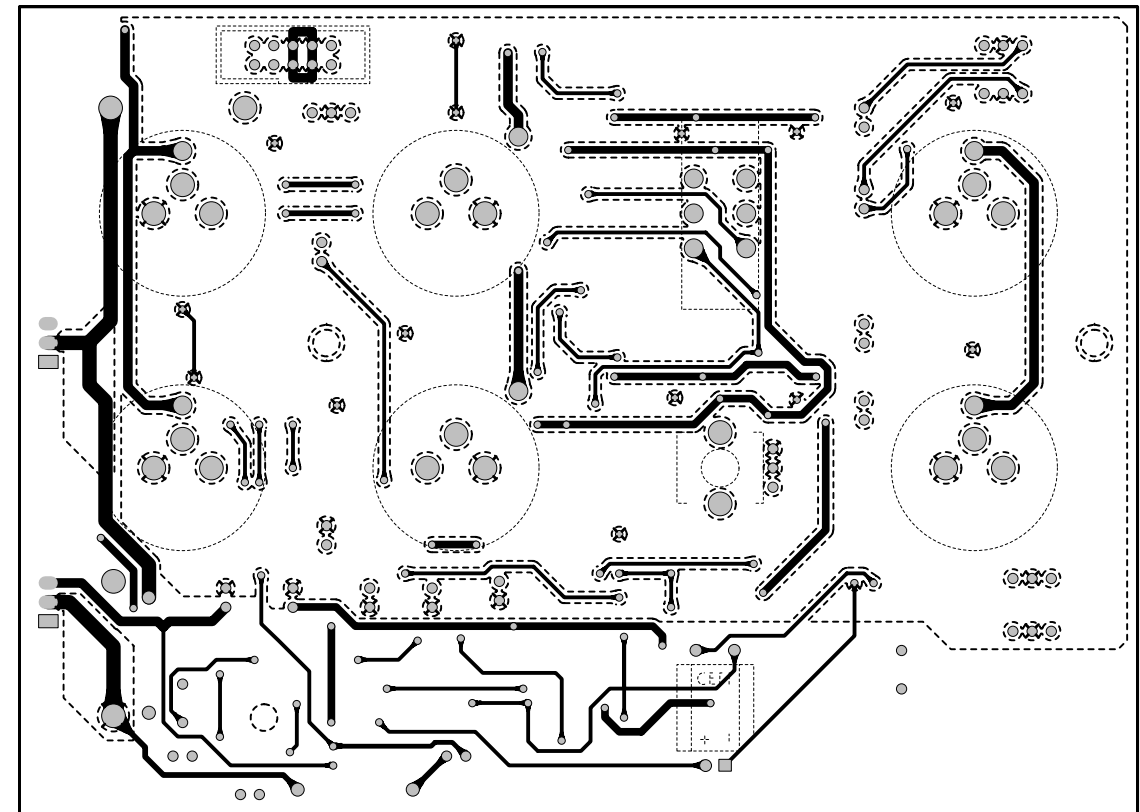

Top of board

D

D

C

C

B

B

A

A

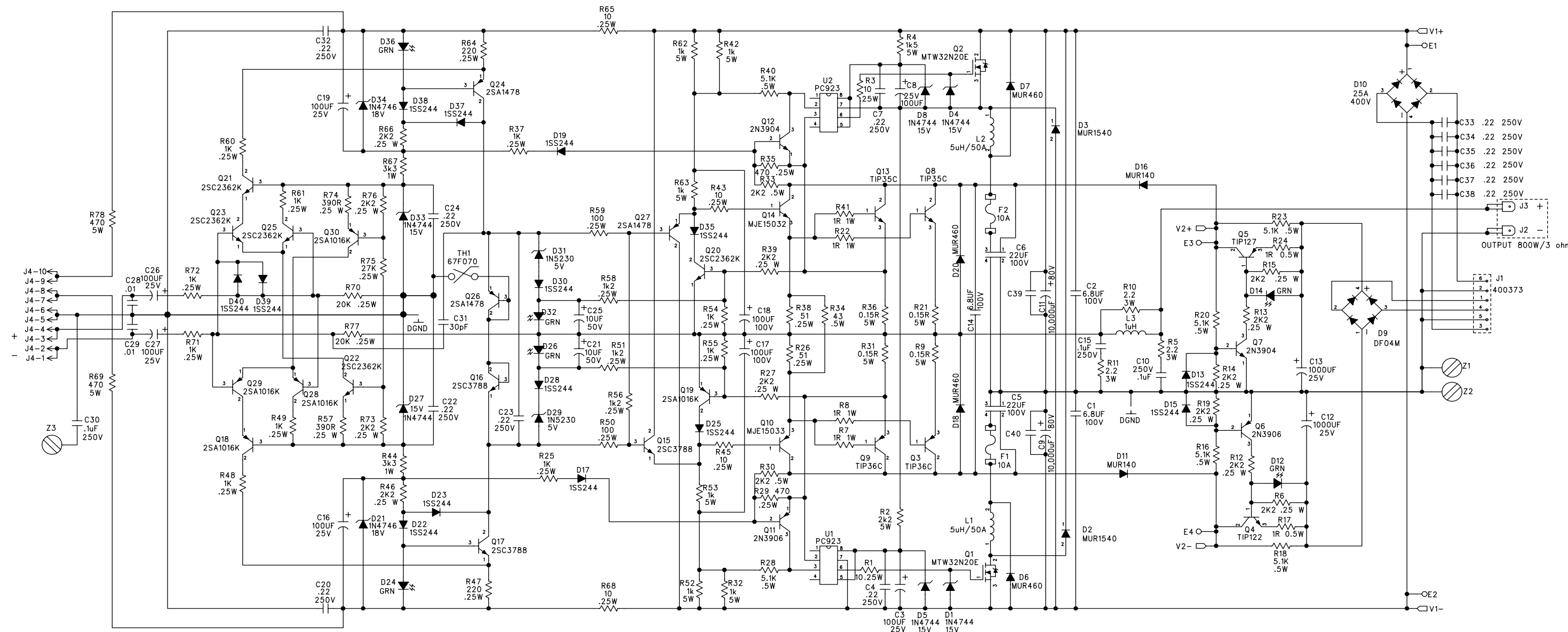

- Z4 450-269-00 PCB, SRS1500: AMP
- FC3 400-129-00 FUSE CLIP .25 DIA PC MNT
- FC4 400-129-00 FUSE CLIP .25 DIA PC MNT
- FC1 400-129-00 FUSE CLIP .25 DIA PC MNT
- FC2 400-129-00 FUSE CLIP .25 DIA PC MNT

UNLESS OTHERWISE SPECIFIED DIMENSIONS ARE IN INCHES TOLERANCES ARE: FRACTIONS: DECIMALS: ANGLES: ±NA .XX ±.01 ±NA .XXX ±.005	APPROVALS	DATE
	DRAWN: STOLTZ	12-28-99
	CHECKED:	
	NP ENG:	
	MATERIAL:	
SEE NOTES		
FINISH:		
SEE NOTES		
DO NOT SCALE DRAWING		

MACKIE Mackie Designs Inc. Woodinville, Wa.	
SCHEMATIC, SRS1500 AMP	
SIZE: D	SCALE: NONE
DWG. NO. 990-269-00	REV. A
DWG FILE:	SHEET 1 OF 1

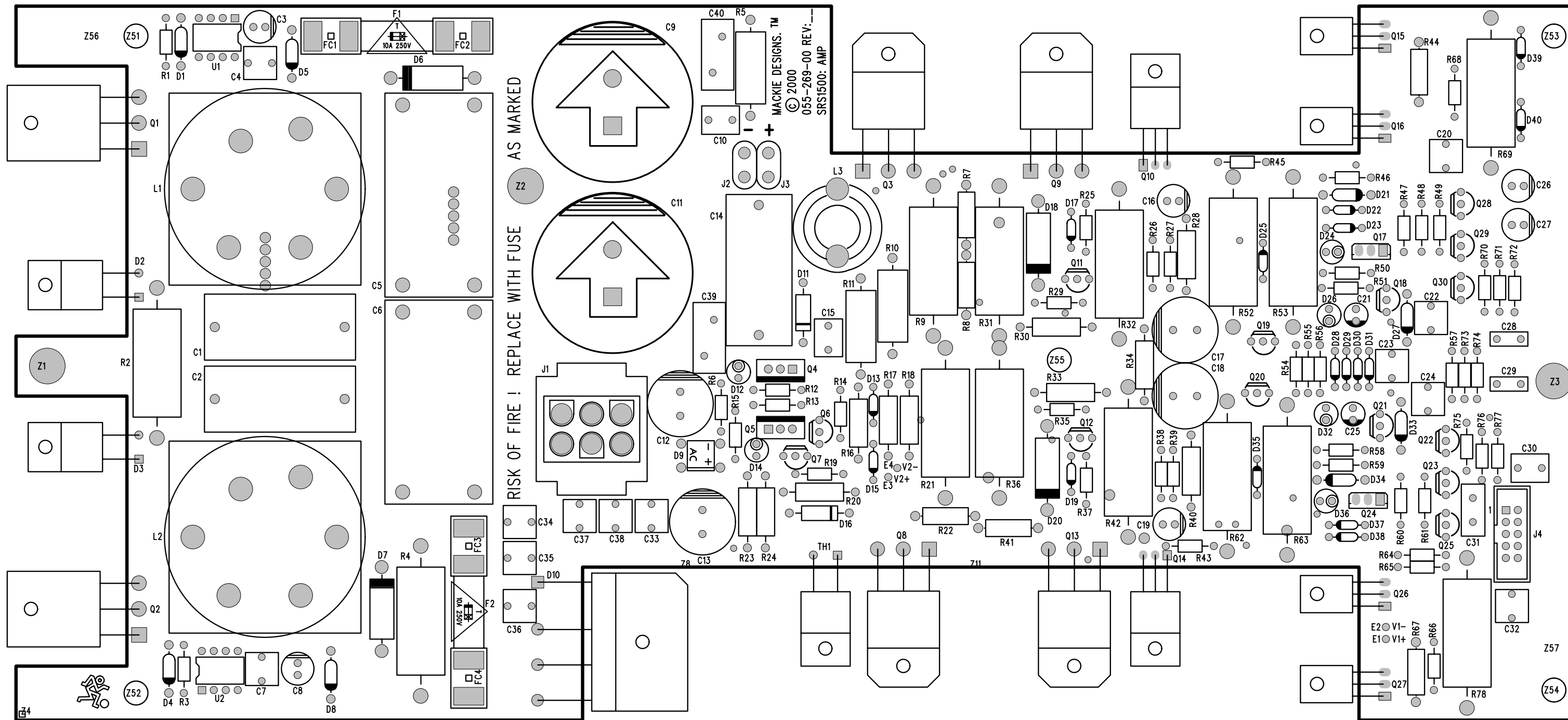

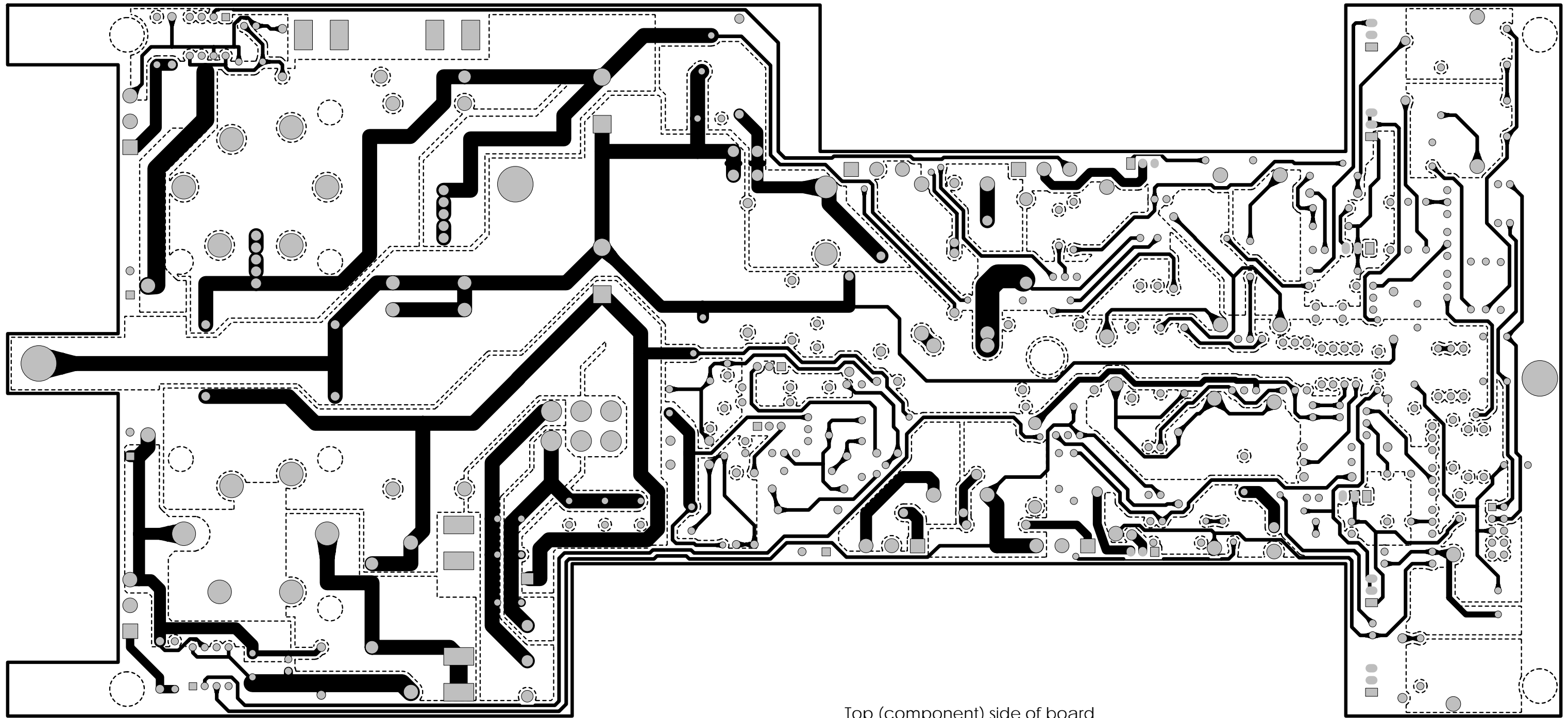

Top (component) side of board

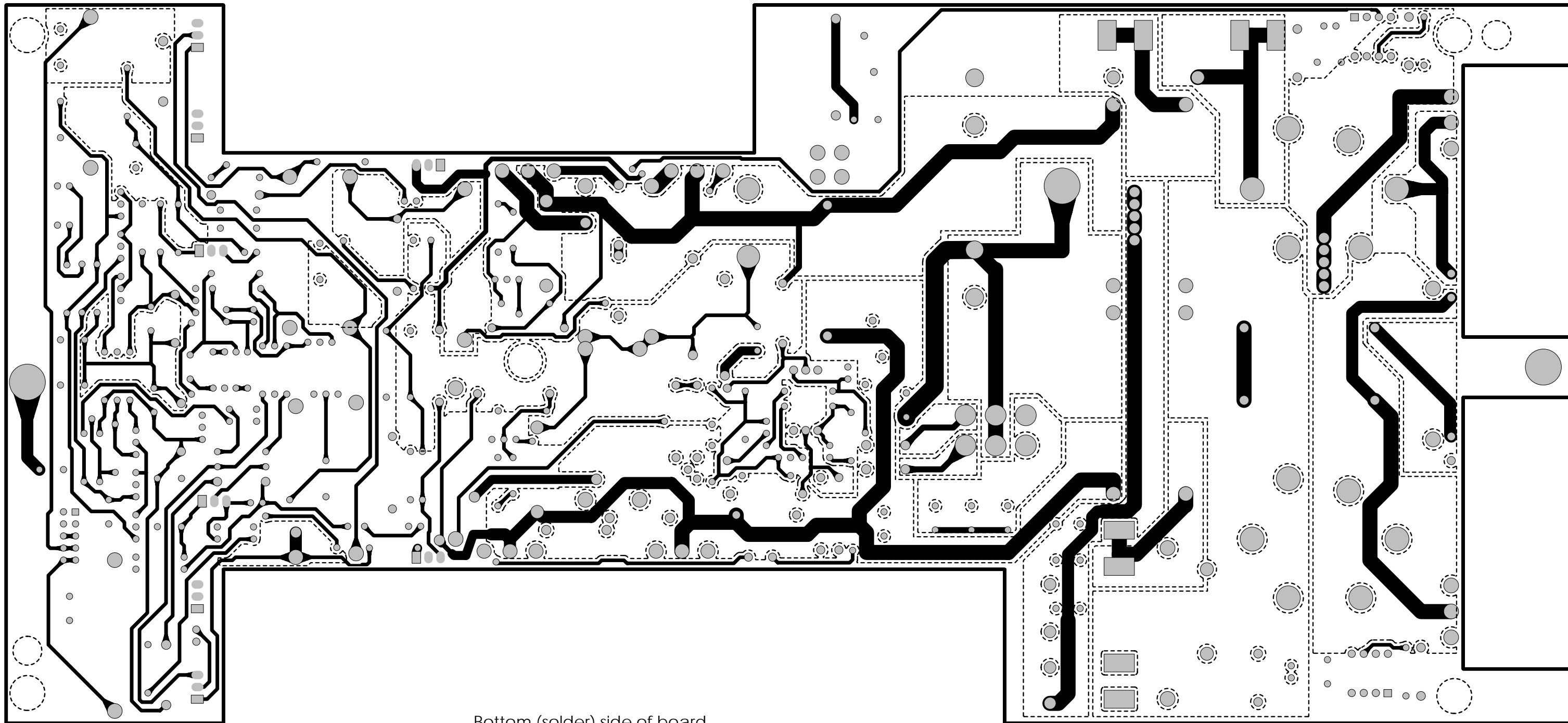

Bottom (solder) side of board

D

D

C

C

B

B

A

A

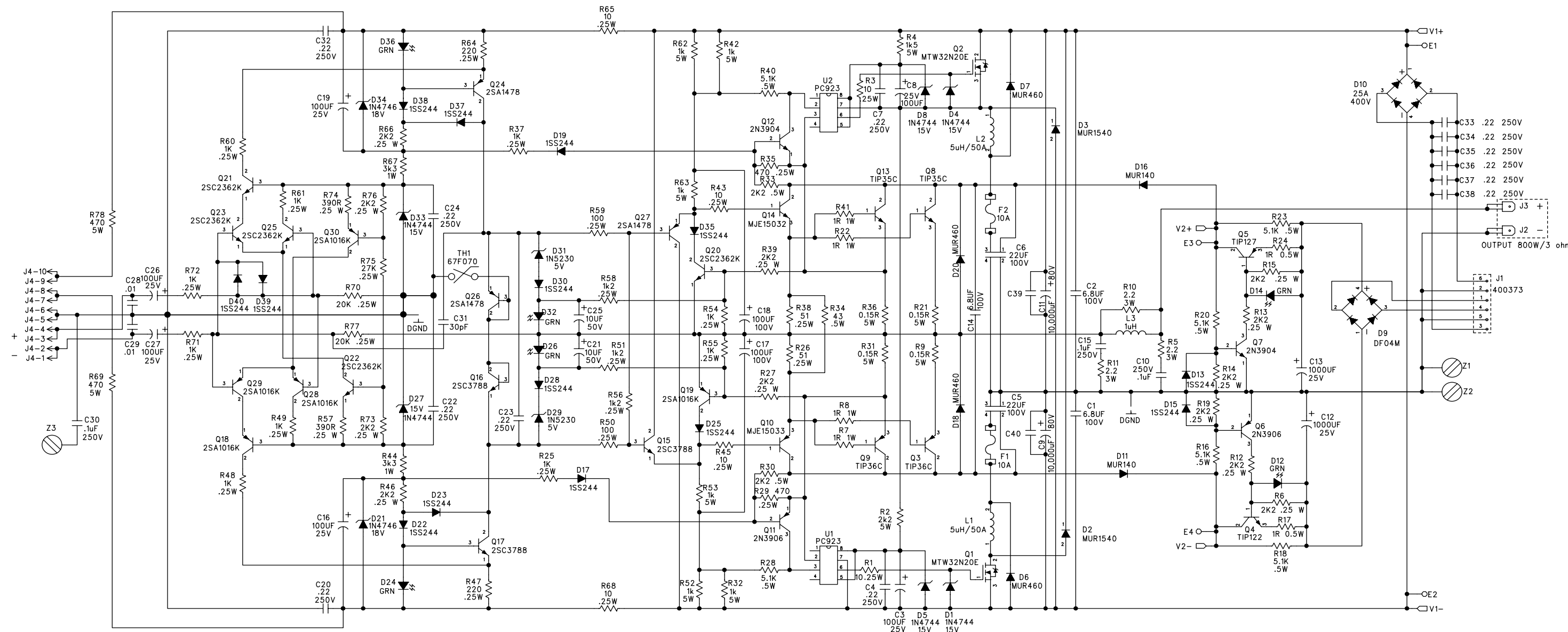

- Z4 450-269-00 PCB, SRS1500: AMP
- FC3 400-129-00 FUSE CLIP .25 DIA PC MNT
- FC4 400-129-00 FUSE CLIP .25 DIA PC MNT
- FC1 400-129-00 FUSE CLIP .25 DIA PC MNT
- FC2 400-129-00 FUSE CLIP .25 DIA PC MNT

UNLESS OTHERWISE SPECIFIED DIMENSIONS ARE IN INCHES TOLERANCES ARE: FRACTIONS: DECIMALS: ANGLES: ±NA ±.XX ±.01 ±NA .XXX ±.005	APPROVALS	DATE
	DRAWN: STOLTZ	12-28-99
	CHECKED:	
	NP ENG:	
	MATERIAL:	
FINISH:	SEE NOTES	
DO NOT SCALE DRAWING	ISSUED:	

MACKIE Mackie Designs Inc. Woodinville, Wa.	
SCHEMATIC, SRS1500 AMP	
SIZE: D	SCALE: NONE
DWG. NO. 990-269-00	REV. A
DWG FILE:	SHEET 1 OF 1

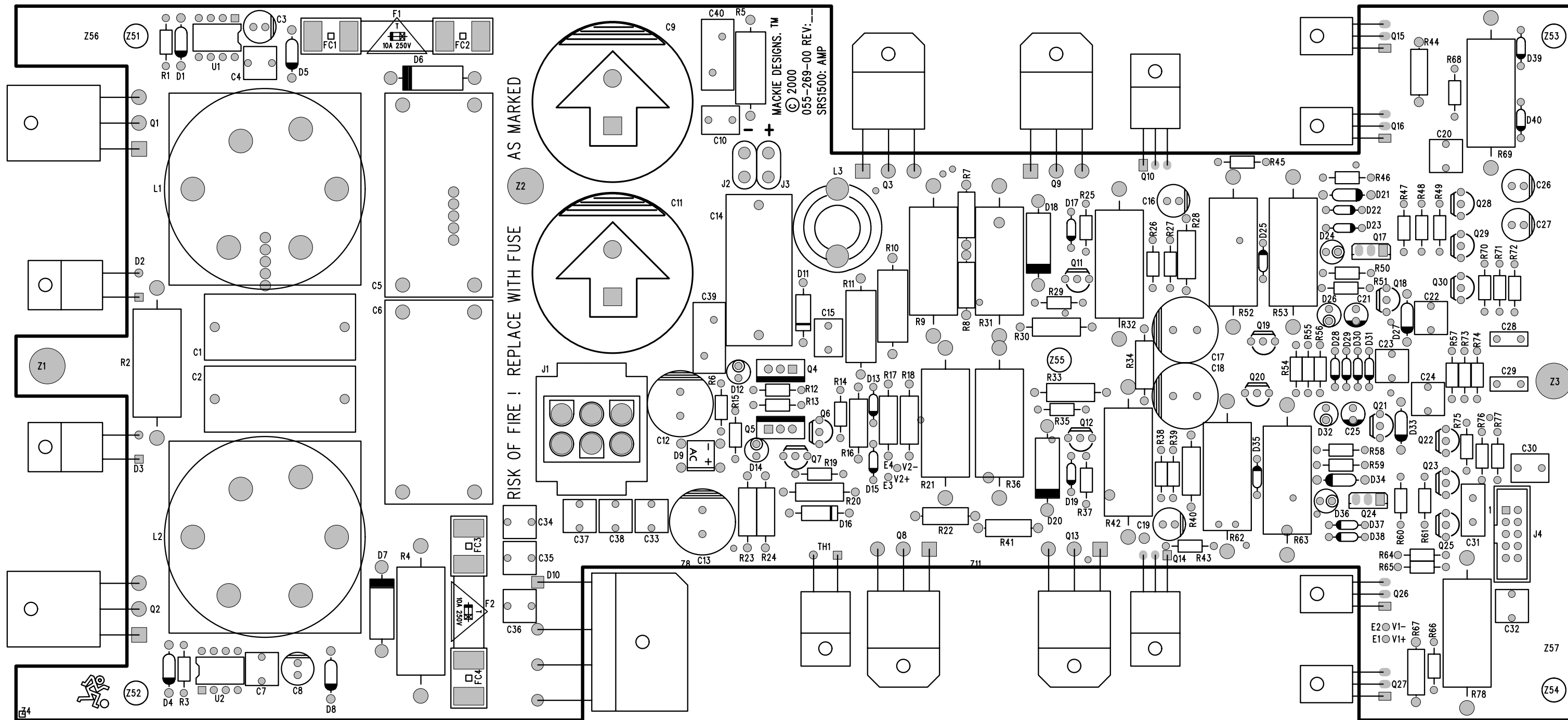

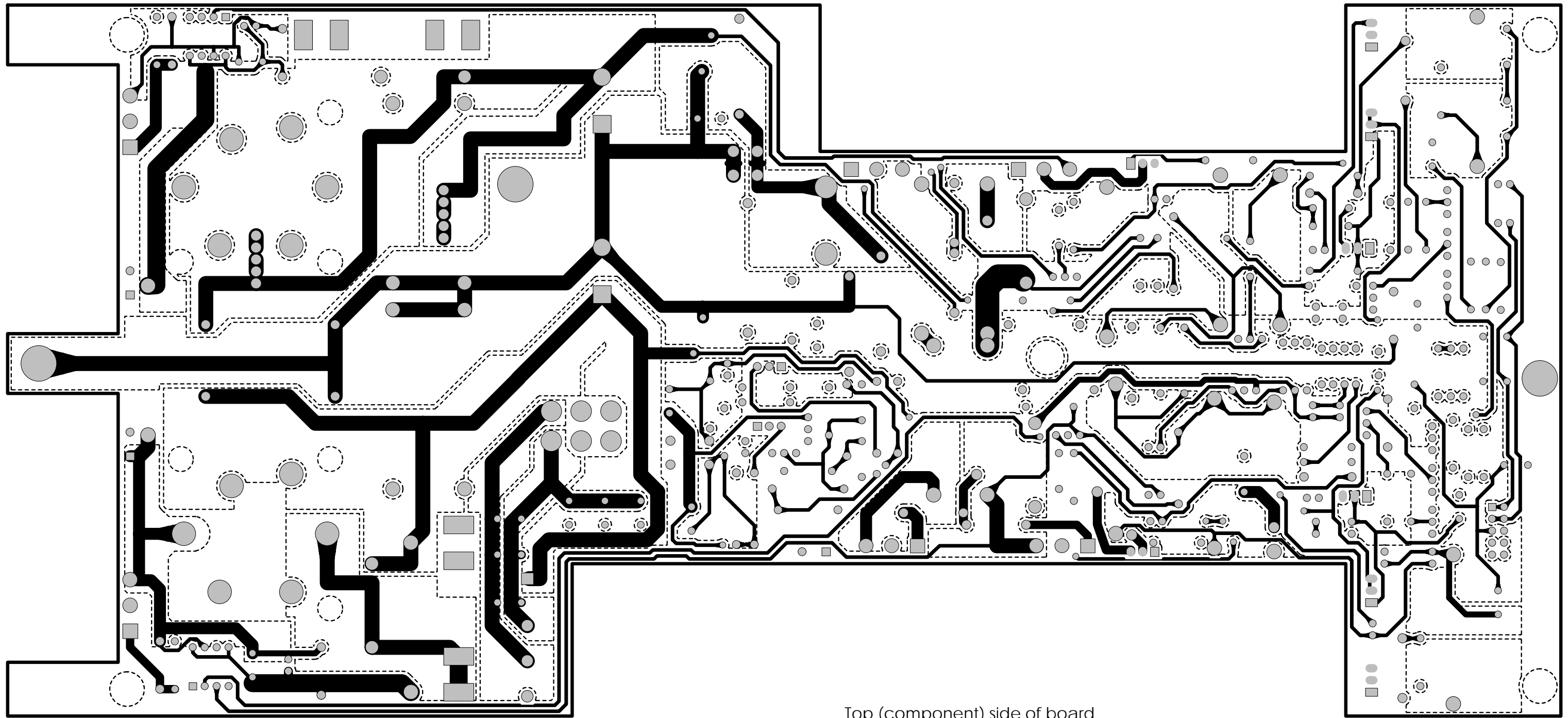

Top (component) side of board

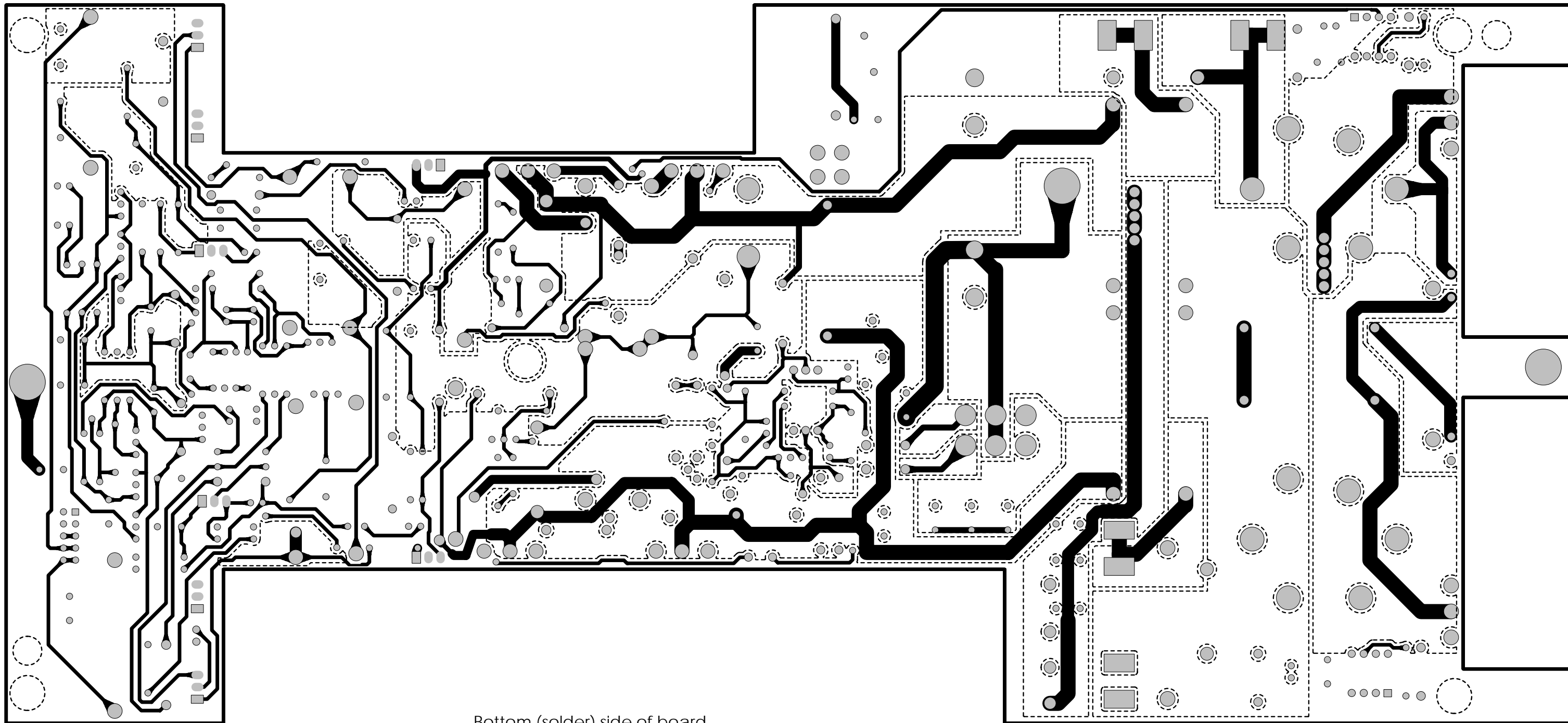

Bottom (solder) side of board

D

C

B

A

D

C

B

A

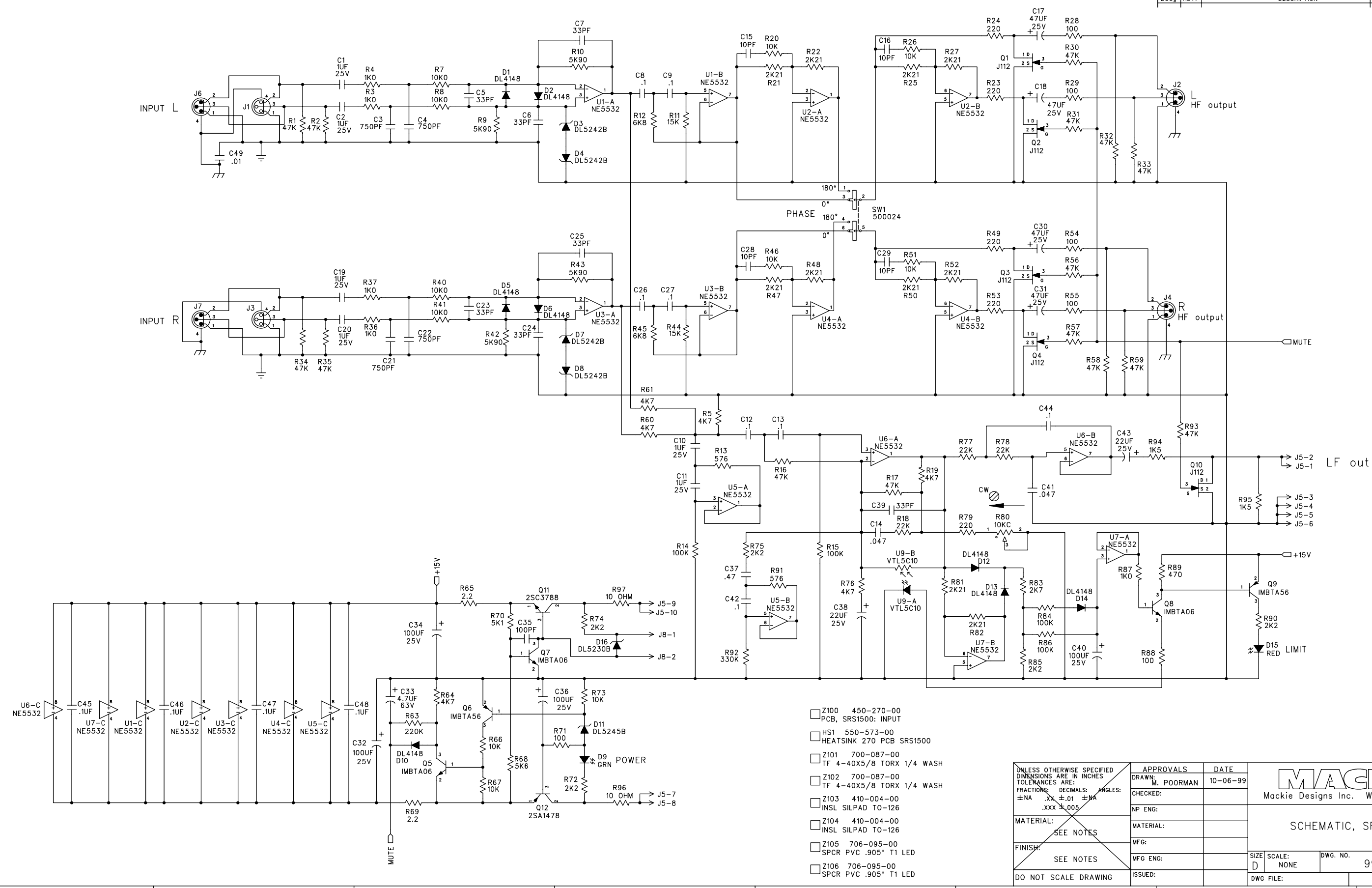

- Z100 450-270-00 PCB, SRS1500: INPUT
- HS1 550-573-00 HEATSINK 270 PCB SRS1500
- Z101 700-087-00 TF 4-40X5/8 TORX 1/4 WASH
- Z102 700-087-00 TF 4-40X5/8 TORX 1/4 WASH
- Z103 410-004-00 INSL SILPAD TO-126
- Z104 410-004-00 INSL SILPAD TO-126
- Z105 706-095-00 SPCR PVC .905" T1 LED
- Z106 706-095-00 SPCR PVC .905" T1 LED

UNLESS OTHERWISE SPECIFIED DIMENSIONS ARE IN INCHES TOLERANCES ARE: FRACTIONS: DECIMALS: ANGLES: ±NA .XX ±.01 ±MA .XXX ±.005	APPROVALS	DATE
	DRAWN: M. POORMAN	10-06-99
	CHECKED:	
	NP ENG:	
MATERIAL: SEE NOTES	MATERIAL:	
FINISH: SEE NOTES	MFG:	
DO NOT SCALE DRAWING	MFG ENG:	
	ISSUED:	

Mackie Designs Inc. Woodinville, Wa.

SCHMATIC, SRS1500: INPUT

SIZE D	SCALE NONE	DWG. NO. 990-270-00	REV. A
DWG FILE:		SHEET 1 OF 1	

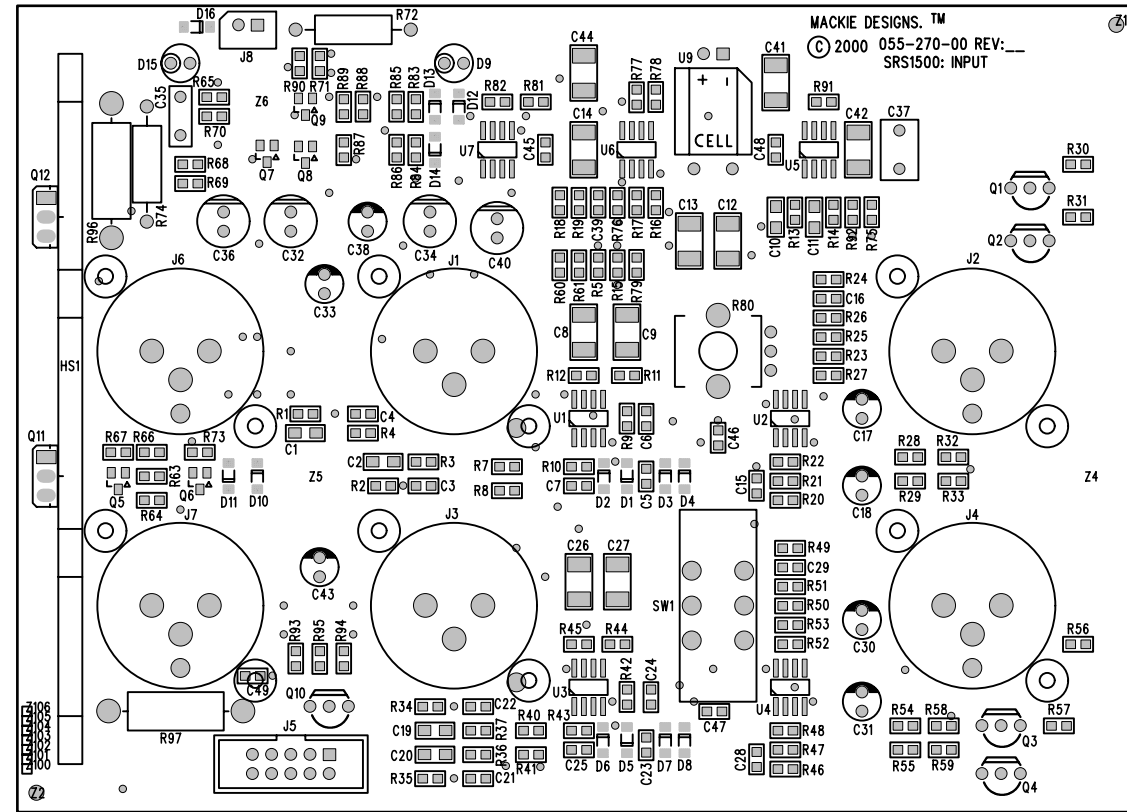

Bottom of board

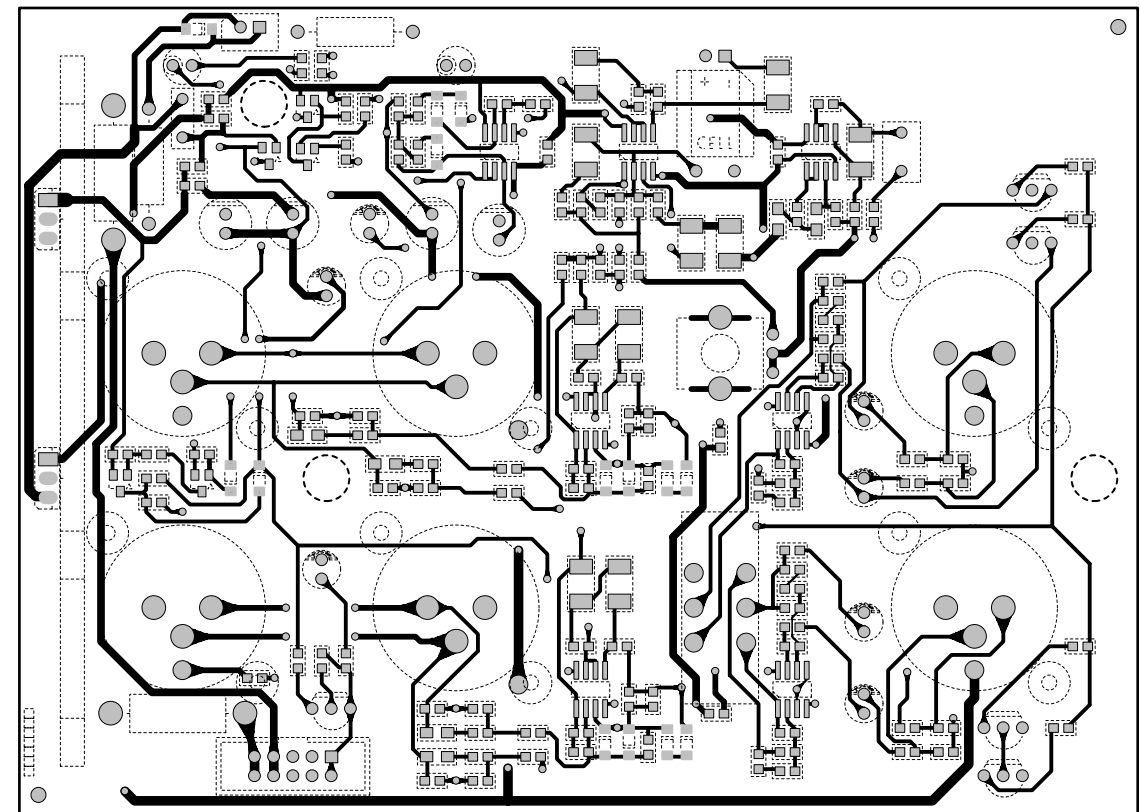
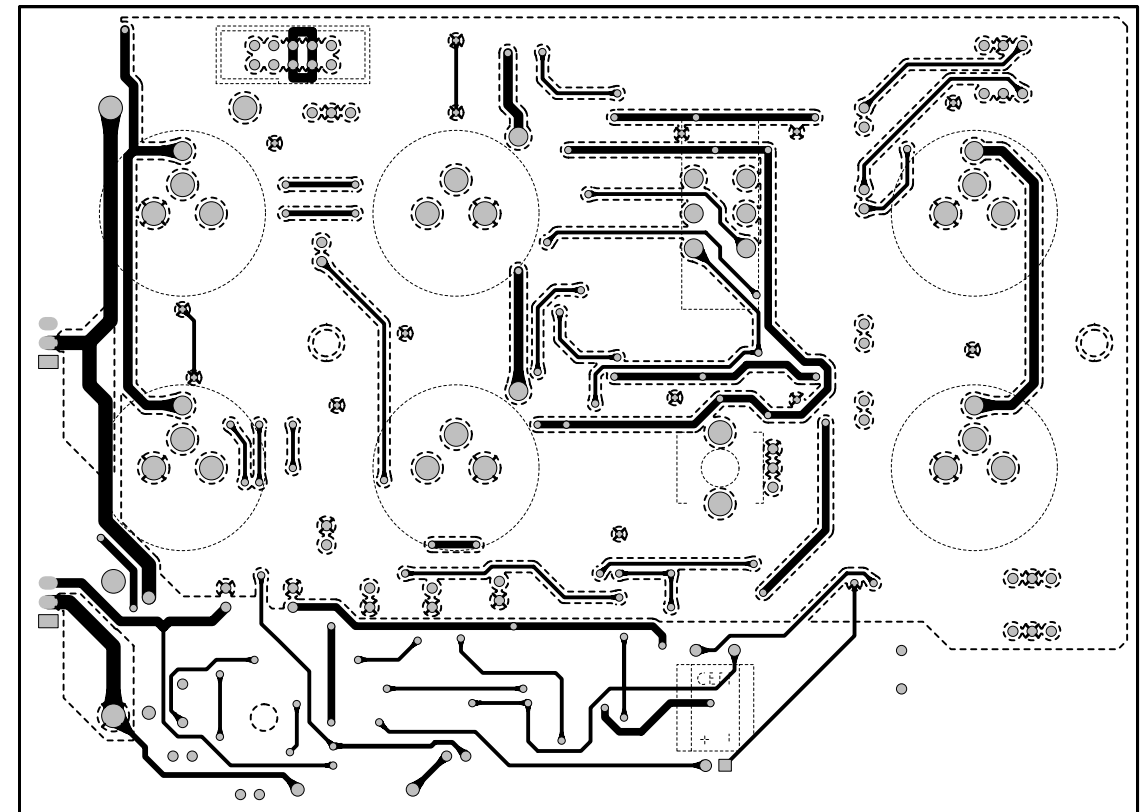

Top of board

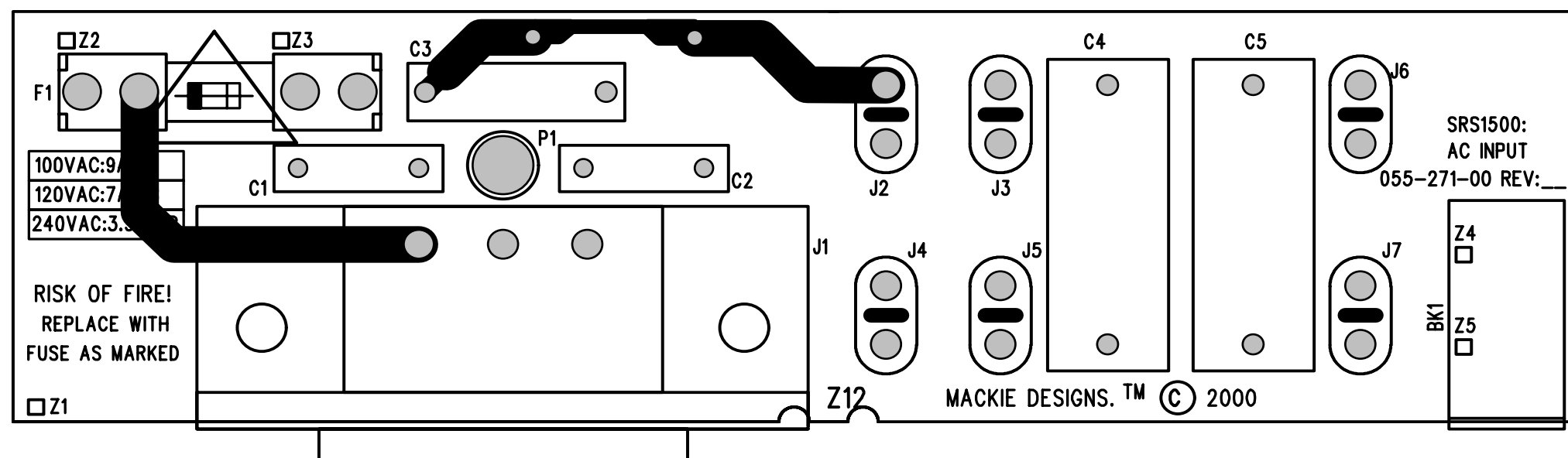
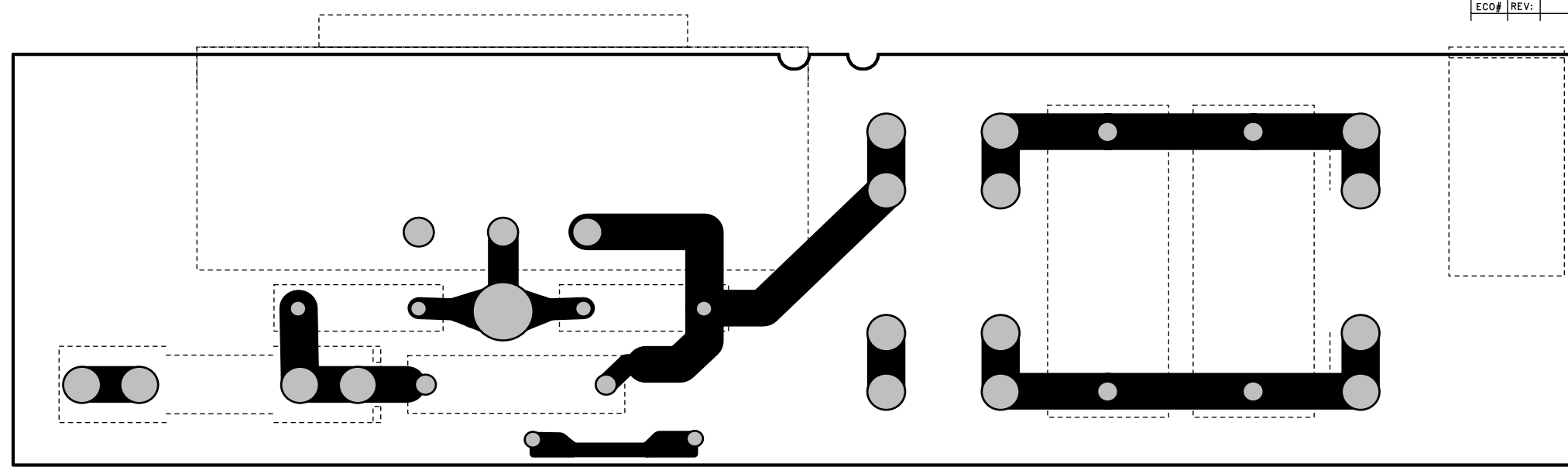

FUSE VALUE CHART

MAINS	F1
100VAC	9A SB
120VAC	7A SB
240VAC	3.5A SB

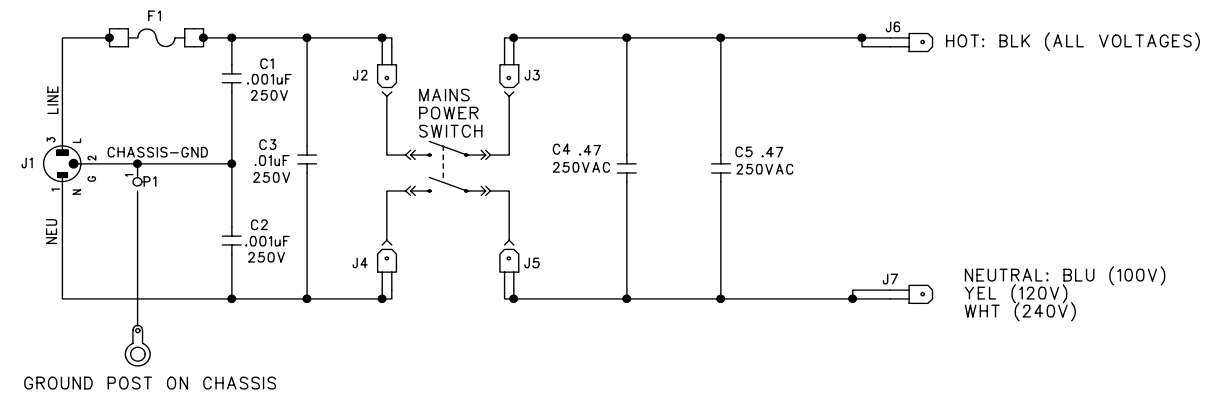

APPROVALS		DATE
DRAWN:	KR	6-10-99
CHECKED:		
NP ENG:		
MATERIAL:		
MFG:		
MFG ENG:		
ISSUED:		

 Mackie Designs Inc. Woodinville, Wa.		SCHEMATIC, SRS1500: AC INPUT	
		SIZE: D	SCALE: NONE
DWG. NO.	990-271-00	REV.	A
DWG. FILE:		SHEET	1 OF 1

CABLE CONNECTIONS (NOT SHOWN)				
ITEM	FROM	REF DES	TO	REF DES
—	055-269-00 (ON 080-101-00 SUBASSY)	J2 BLK J3 RED	SPEAKER SPEAKER	BLK RED
—	055-270-00 (ON 080-101-00 SUBASSY)	J8	055-313-00	CONN

DWG. NO.	090-104-00	SHT	1	REV	B	1
REVISIONS						
ECD#	REV.	DESCRIPTION	REV. BY	APP. BY	DATE	
	A	PRODUCTION RELEASE				
2701	B	CHANGE HANDLE SCREW AND ADD GASKETING NOTES.				

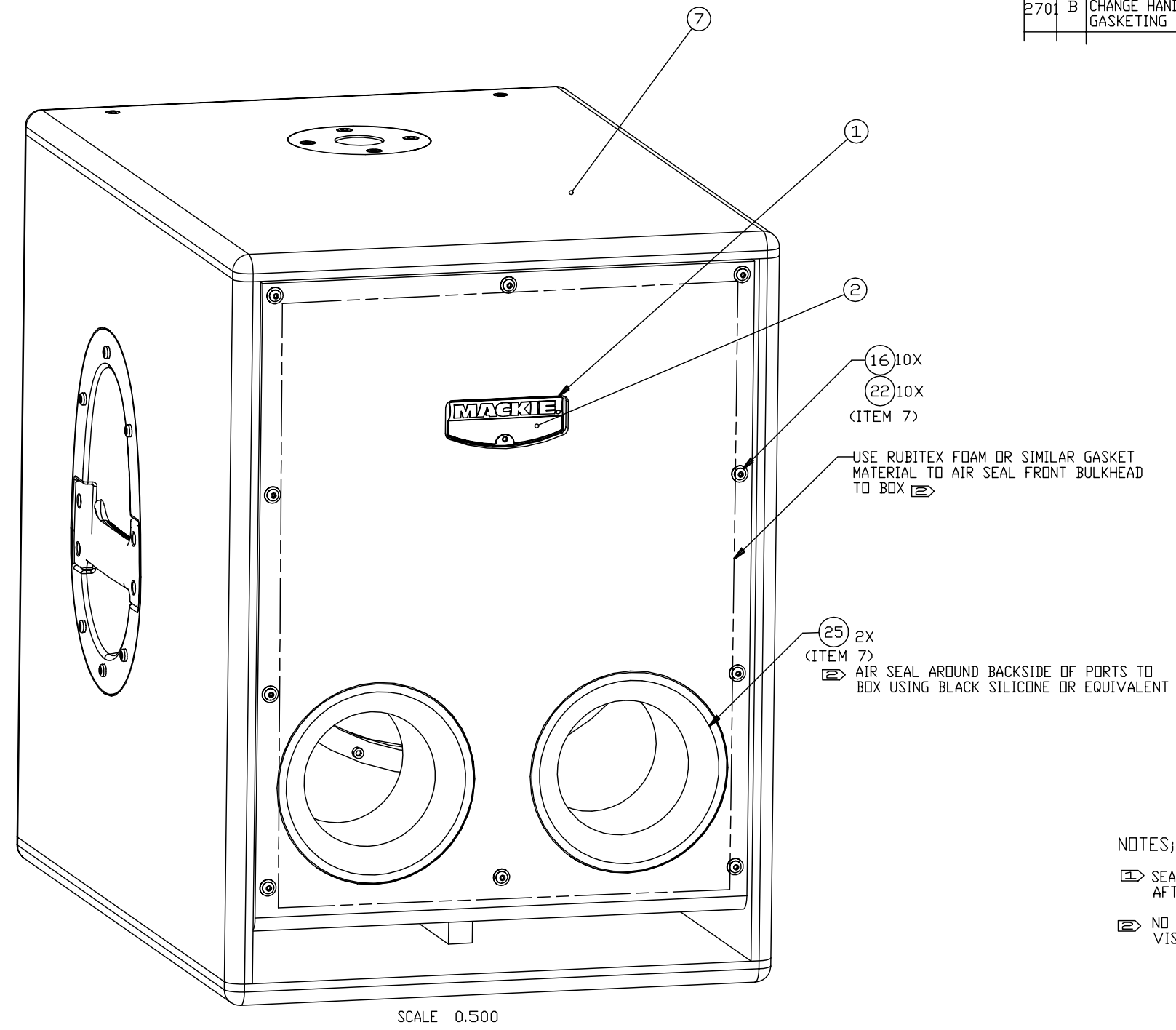

NOTES; UNLESS OTHERWISE SPECIFIED

➡ SEAL HOLES IN BULKHEADS FOR AIR LEAKS AFTER ROUTING WIRES.

➡ NO SILICONE OR GASKETING MATERIAL TO BE VISIBLE FROM EXTERIOR OF FINISHED CABINET.

DIMENSION AND TOLERANCES ARE IN ACCORDANCE WITH ASME Y14.5-1994 THE INFORMATION CONTAINED HEREIN IS PROPRIETARY AND CONFIDENTIAL PROPERTY OF MACKIE DESIGNS INC. DO NOT SCALE DRAWING	UNLESS OTHERWISE SPECIFIED DIMENSIONS ARE IN INCHES ALL ANGLES ARE 90° TOLERANCES ARE: FRACTIONS: .XX± DECIMALS: .XXX± ANGLES: ±	APPROVALS DRAWN: JH CHECKED: NP ENGINEERING: JEFF H. 3.7.00 MATERIAL: MIKE B. 3.9.00 MANUFACTURING: MFG ENGINEERING: MIKE G. 3.8.00 ISSUED: PATTI C. 3.9.00	DATE 12.13.99	MACKIE™ Mackie Designs Inc. Woodinville, Wa FINAL ASSY, SRS1500
	MATERIAL:	MATERIAL:	SIZE: D	
	FINISH:	MFG ENGINEERING:	SCALE: 1/4	
		ISSUED:	DWG. NO. 090-104-00	
				REV. B
				DWG FILE 090-104-00
				SHEET 1 OF 2

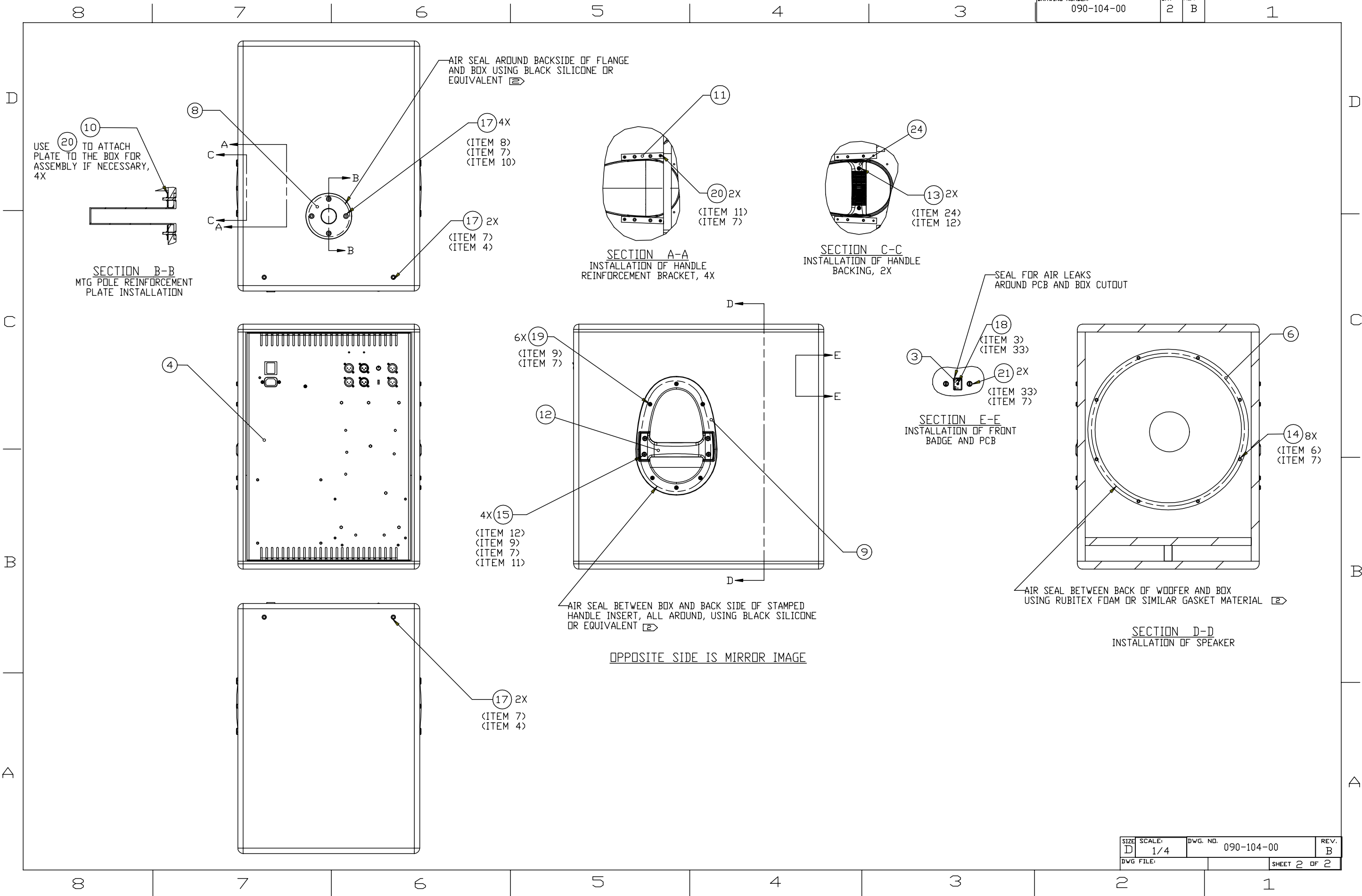

SIZE: D	SCALE: 1/4	DWG. NO: 090-104-00	REV: B
DWG FILE:		SHEET 2 OF 2	

DWG. NO.	080-101-00	SHT	1	REV.	A	1
REVISIONS						
ECD#	REV.	DESCRIPTION	REV. BY	APP. BY	DATE	
	A	PRODUCTION RELEASE				

CABLE CONNECTIONS (NOT SHOWN)					
ITEM	FROM	REF DES	TO	REF DES	
①	055-271-00	J2	PWR SWITCH	WHT	
②	055-271-00	J4	PWR SWITCH	BLK	
①	055-271-00	J3	PWR SWITCH	WHT	
②	055-271-00	J5	PWR SWITCH	BLK	
—	055-271-00	P1	CHASSIS	GND	
③	055-270-00	J8	(FINAL ASSY-LEDS)		
④	055-269-00	J4	055-270-00	J5	
—	080-155-00	8pin	055-269-00	J1	
—	080-155-00	WHT	055-271-00	J6	
—	080-155-00	BLK	055-271-00	J7	
④7	055-269-00	J2 - BLK J3 + RED	(FINAL ASSY-SPKR)		

SAME COLOR WIRES ARE INTERCHANGEABLE.
SEE SH2 FOR COLOR TERMINATION LUGS
ON SWITCH

SECURE FERRITE BEAD
PER MFG INSTR.

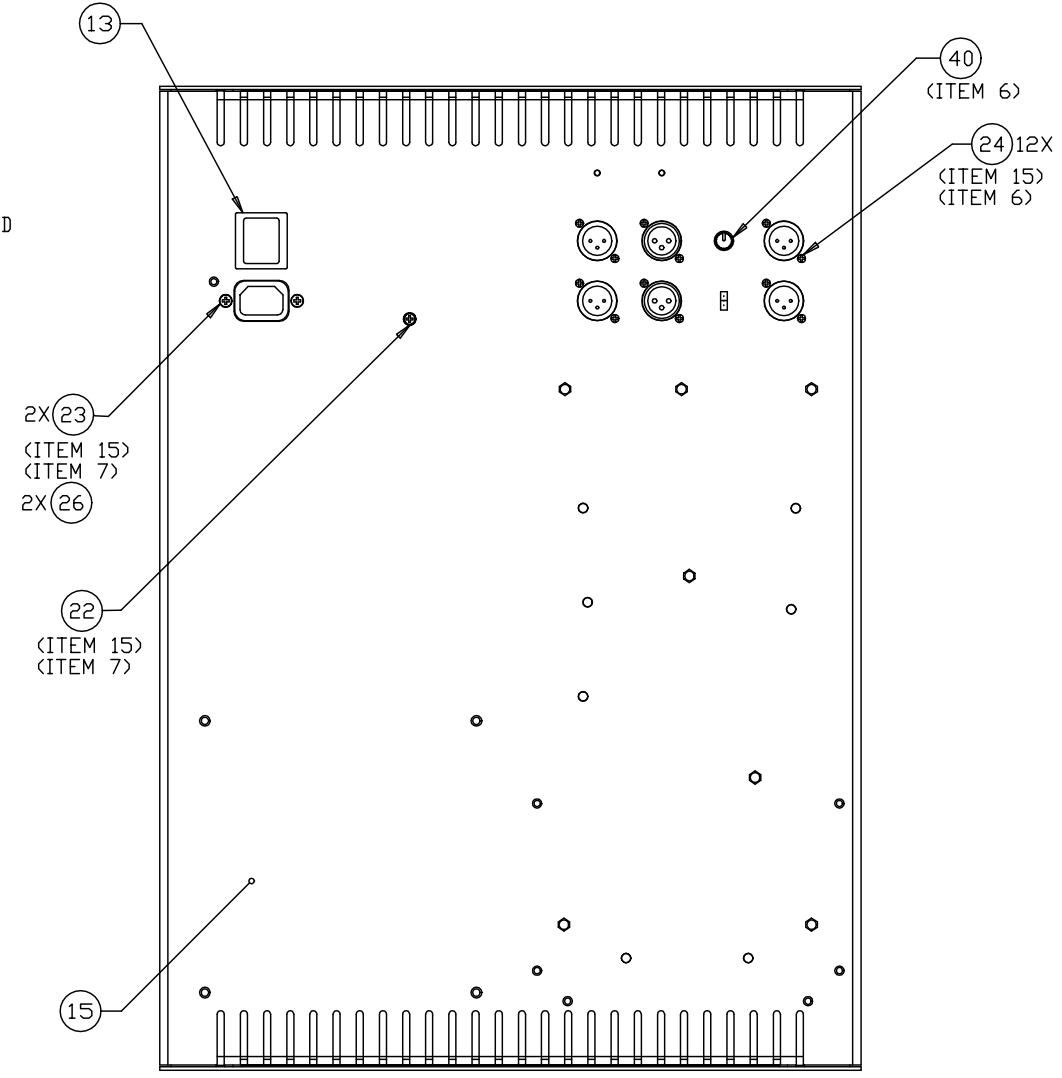

SCALE 0.500

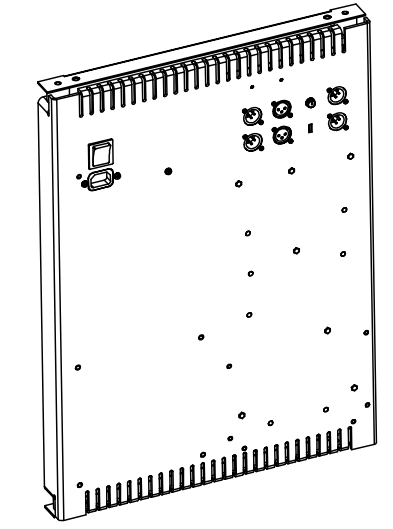

SCALE 0.250

- NOTES, UNLESS OTHERWISE SPECIFIED
- ① COAT BOTH SIDES OF INSULATOR USING ④3 .
 - ② COAT BOTTOM SIDE OF HEATSINK USING ④3 .
 - ③ USE ③8 TO SECURE WIRING PER MANUFACTURING INSTRUCTIONS.
 - ④ USE ④5 TO LOCK ITEM 4 INTO PCB CONNECTOR.
 - ⑤ USE ④6 TO LOCK NUT TO THREADS.

DIMENSION AND TOLERANCES ARE IN ACCORDANCE WITH ASME Y14.5-1994	UNLESS OTHERWISE SPECIFIED DIMENSIONS ARE IN INCHES ALL ANGLES ARE 90° TOLERANCES ARE: FRACTIONS: .XX± ANGLES: .XXX±	APPROVALS	DATE	 Mackie Designs Inc. Woodinville, Wa
		DRAWN: JH	3.7.00	
THE INFORMATION CONTAINED HEREIN IS PROPRIETARY AND CONFIDENTIAL PROPERTY OF MACKIE DESIGNS INC.	MATERIAL:	CHECKED:		
DO NOT SCALE DRAWING	FINISH:	NP ENGINEERING:		
		MATERIAL:		SUBASSEMBLY, AMPLIFIER, SRS1500
		MANUFACTURING:		
		MFG ENGINEERING:		SIZE: D
		ISSUED:		SCALE: 1/2
				DWG. NO. 080-101-00
				REV. A
				DWG FILE: 080-101-00
				SHEET 1 OF 2

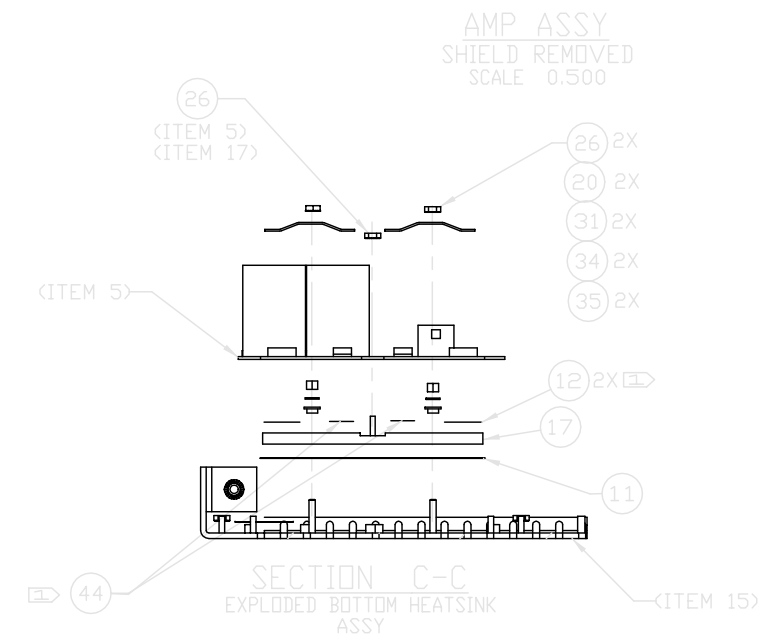
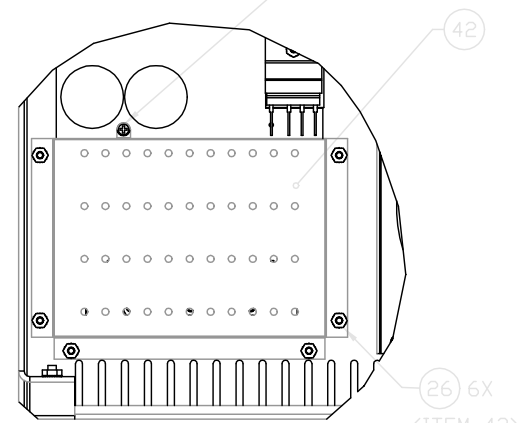
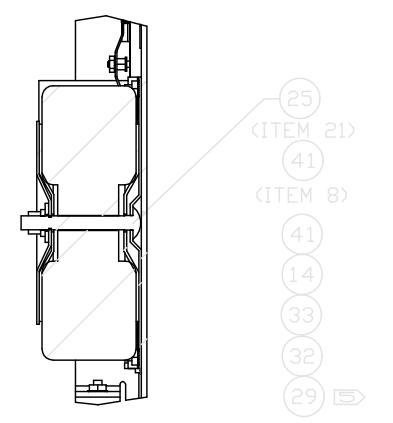
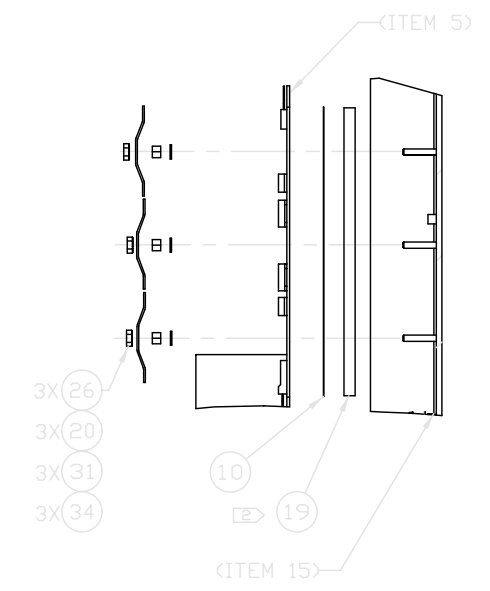
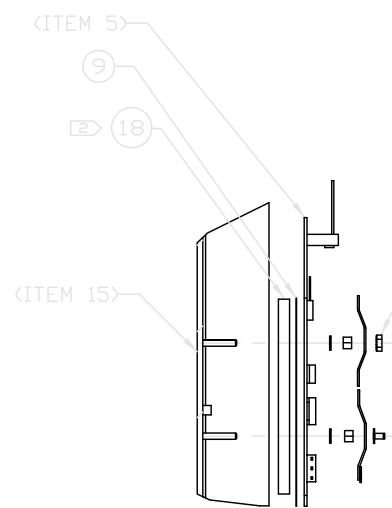
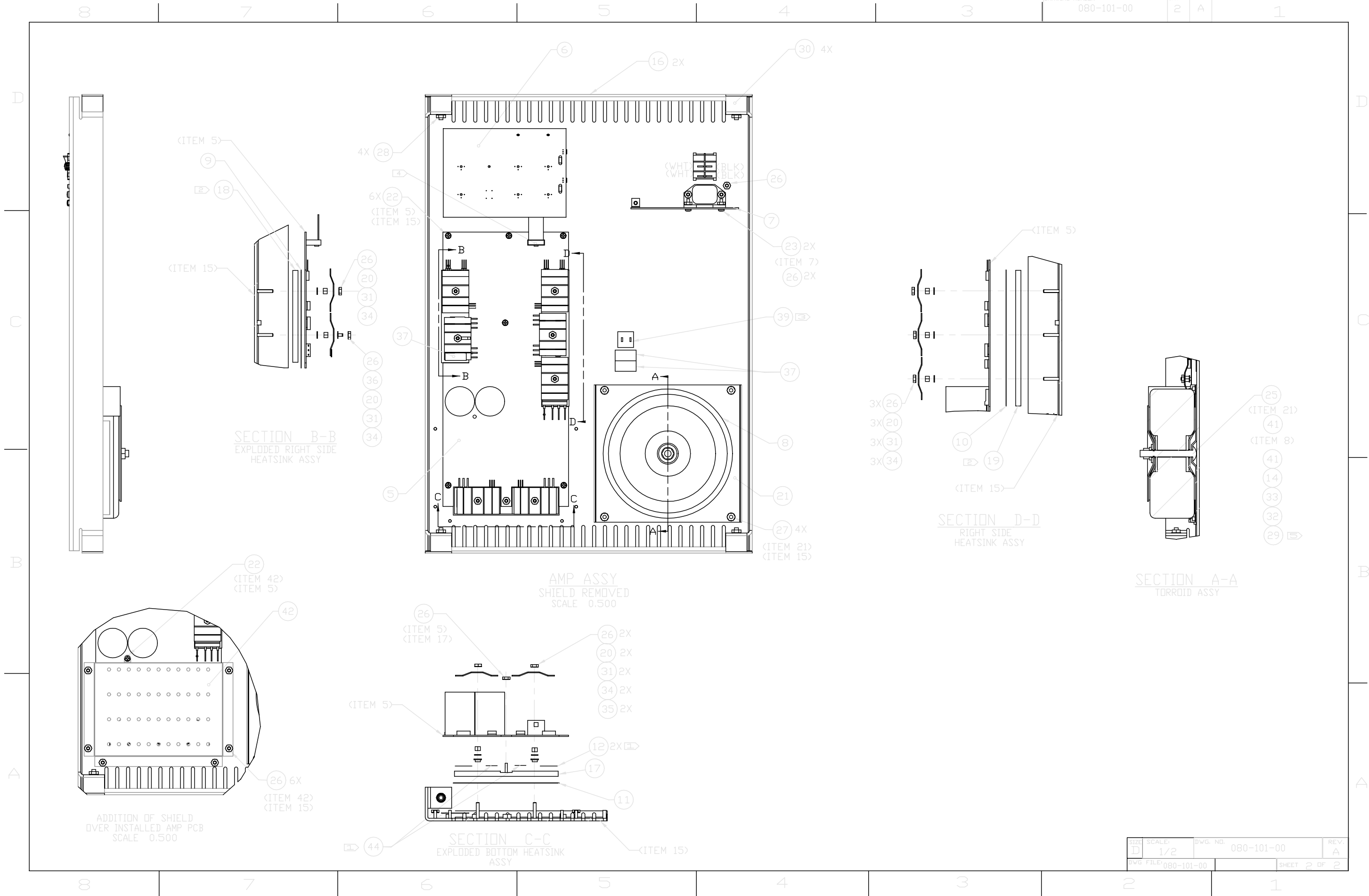

SIZE: D	SCALE: 1/2	DWG. NO.: 080-101-00	REV: A
DVD FILE: 080-101-00		SHEET 2 OF 2	