

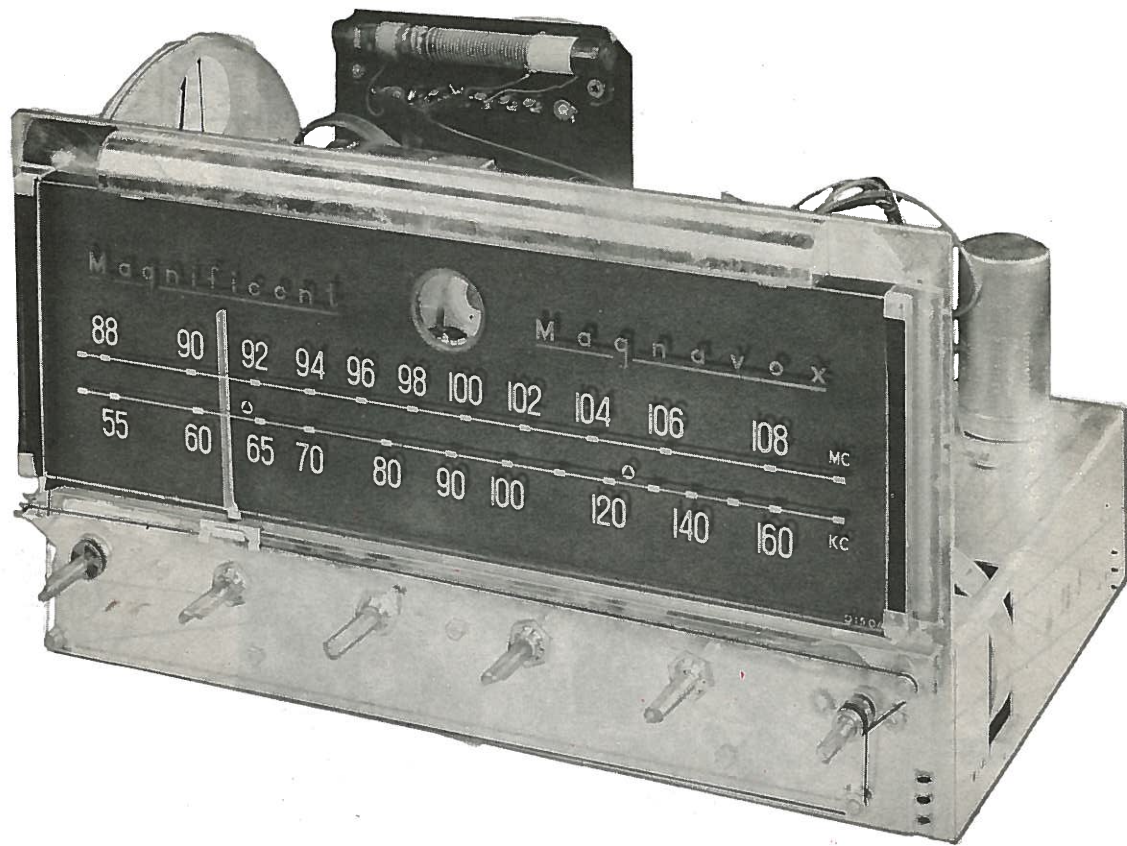

**MAGNAVOX
 CHASSIS CR730AA**



**MAGNAVOX
 CHASSIS CR730AA**

TRADE NAME	Magnavox Chassis CR730AA	
MANUFACTURER	Magnavox Co., 2131 Bueter Rd., Fort Wayne, Ind.	
TYPE SET	Externally Powered FM-AM Tuner	
TUBES (Nine)	Types 6BZ6 RF Amplifier, 6U8 FM Mixer-Osc., 6BE6 AM Converter, 6BA6 1st. IF Amplifier, 6BA6 2nd. FM IF Amplifier, 6AL5 Ratio Detector, 6AV6 Phono Preamp., 12AT7 AF Amp. -Cath. Follower, 6E5 Tuning Ind.	
TUNING RANGE-BROADCAST	540KC-1620KC	FREQ. MOD. 88MC-108MC

HOWARD W. SAMS & CO., INC. • Indianapolis 5, Indiana

"The listing of any available replacement part herein does not constitute in any case a recommendation, warranty or guaranty by Howard W. Sams & Co., Inc., as to the quality and suitability of such replacement part. The numbers of these parts have been compiled from information furnished to Howard W. Sams & Co., Inc., by the manufacturers of the particular type of replacement part listed."
 "Reproduction or use, without express permission, of editorial or pictorial content, in any manner, is prohibited. No patent liability is assumed with respect to the use of the information contained herein. Copyright 1957 by Howard W. Sams & Co., Inc., Indianapolis 5, Indiana, U. S. of America. Copyright under international Copyright Union. All rights reserved under Inter-American Copyright Union (1910) by Howard W. Sams & Co., Inc." Printed in U. S. of America

tent, in any manner, is prohibited. No patent liability is assumed with respect to the use of the information contained herein. Copyright 1957 by Howard W. Sams & Co., Inc., Indianapolis 5, Indiana, U. S. of America. Copyright under international Copyright Union. All rights reserved under Inter-American Copyright Union (1910) by Howard W. Sams & Co., Inc." Printed in U. S. of America

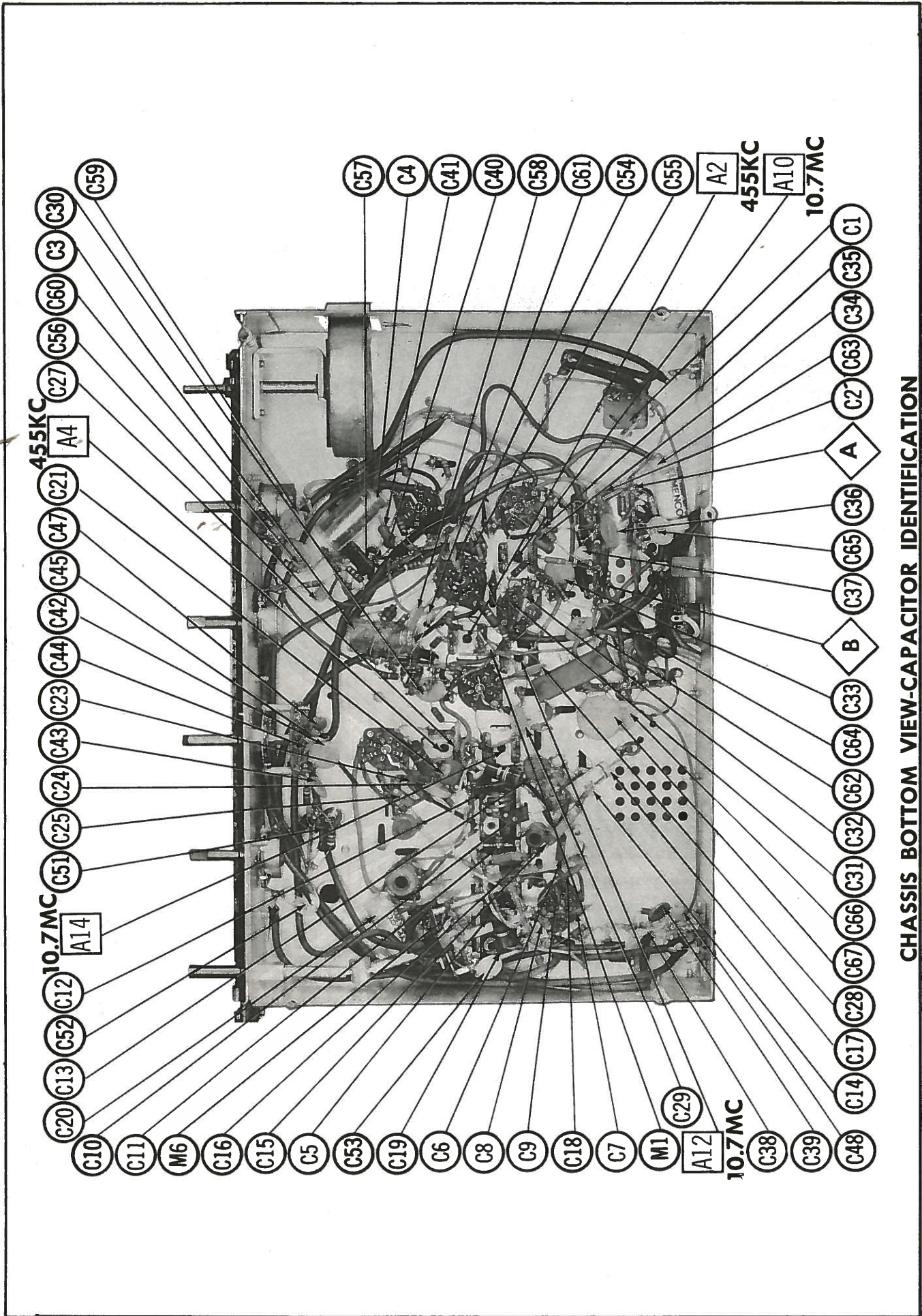

CHASSIS BOTTOM VIEW-CAPACITOR IDENTIFICATION

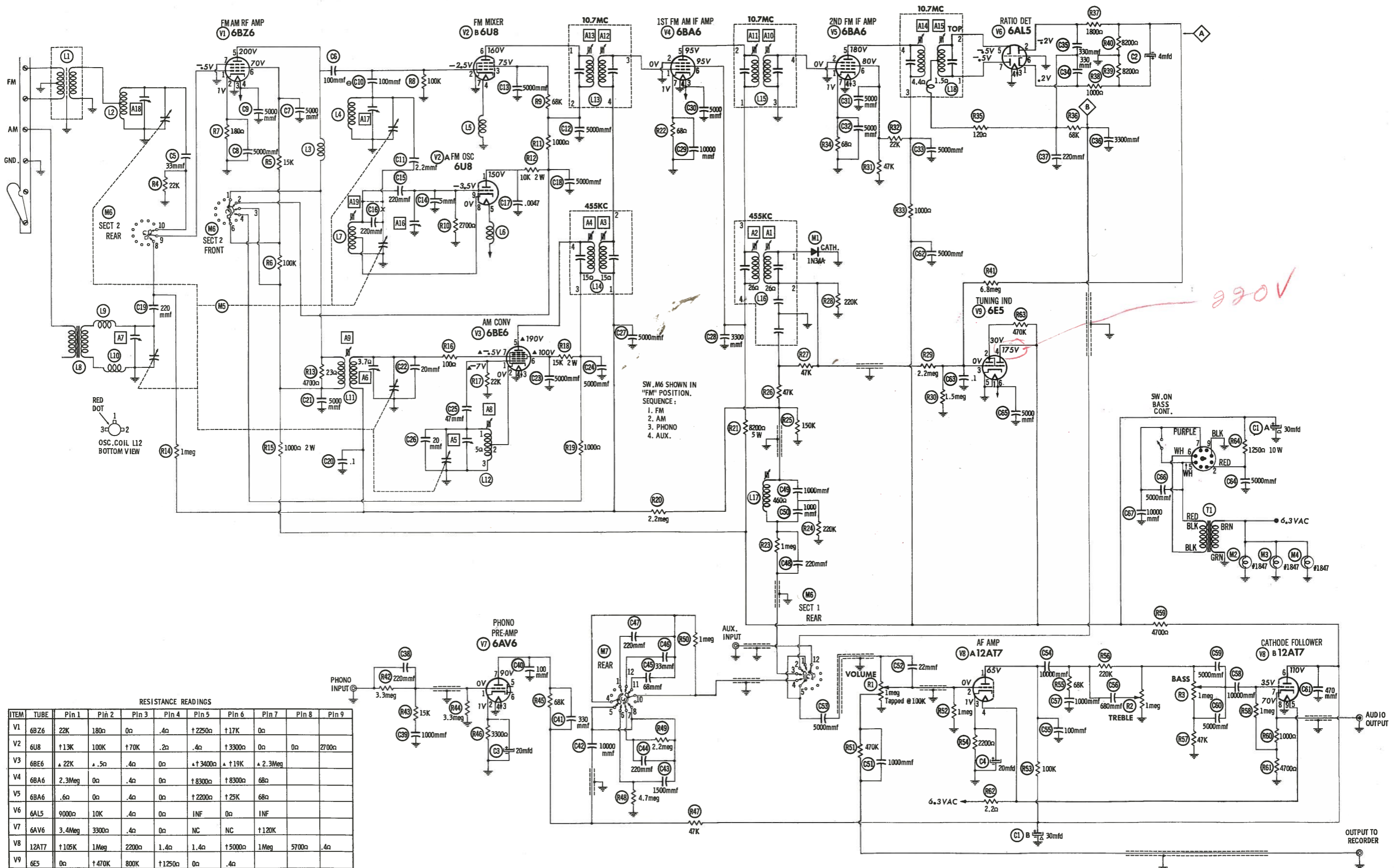

NOTE

SW. M6 SHOWN IN "FM" POSITION. SEQUENCE:
 1. FM
 2. AM
 3. PHONO
 4. AUX.

RESISTANCE READINGS

ITEM	TUBE	Pin 1	Pin 2	Pin 3	Pin 4	Pin 5	Pin 6	Pin 7	Pin 8	Pin 9
V1	6BZ6	22K	180Ω	0Ω	.4Ω	†2250Ω	†17K	0Ω		
V2	6U8	†13K	100K	†70K	.2Ω	.4Ω	†3300Ω	0Ω	0Ω	2700Ω
V3	6BE6	▲22K	▲.5Ω	.4Ω	0Ω	▲†3400Ω	▲†19K	▲2.3Meg		
V4	6BA6	2.3Meg	0Ω	.4Ω	0Ω	†8300Ω	†8300Ω	68Ω		
V5	6BA6	.6Ω	0Ω	.4Ω	0Ω	†2200Ω	†25K	68Ω		
V6	6AL5	9000Ω	10K	.4Ω	0Ω	INF	0Ω	INF		
V7	6AV6	3.4Meg	3300Ω	.4Ω	0Ω	NC	NC	†120K		
V8	12A7	†105K	1Meg	2200Ω	1.4Ω	1.4Ω	†5000Ω	1Meg	5700Ω	.4Ω
V9	6E5	0Ω	†470K	800K	†1250Ω	0Ω	.4Ω			

ALL MEASUREMENTS TAKEN IN "FM" POSITION UNLESS OTHERWISE NOTED.
 ▲ MEASURED IN "AM" POSITION.
 † MEASURED FROM PIN 2 OF POWER PLUG.
 NC NO CONNECTION.

ALIGNMENT INSTRUCTIONS

ALIGNMENT INSTRUCTIONS—READ CAREFULLY BEFORE ATTEMPTING ALIGNMENT

Volume control should be at maximum position. Output of signal generator should be no higher than necessary to obtain an output reading. Use an insulated alignment screwdriver for adjusting. Treble control to sharp tune position.

AM ALIGNMENT

DUMMY ANTENNA	SIGNAL GENERATOR COUPLING	SIGNAL GENERATOR FREQUENCY	BAND SWITCH POS.	RADIO DIAL SETTING	OUTPUT METER	ADJUST	REMARKS
1. .01MFD	High side to pin 7 (grid) of 6BE6 (V3). Low side to chassis.	455KC (400%Mod)	AM	1000KC	Across voice coil	A1, A2, A3, A4	Adjust for maximum output.
2. 10MMF	High side to AM antenna terminal. Low side to chassis.	1400KC	"	1400KC	"	A5, A6, A7	"
3. "	"	800KC	"	800KC	"	A8, A9	Adjust for maximum output. Repeat steps 2 and 3.

FM IF ALIGNMENT USING AM SIGNAL GENERATOR AND VTVM

DUMMY ANTENNA	SIGNAL GENERATOR COUPLING	SIGNAL GENERATOR FREQUENCY	BAND SWITCH POS.	RADIO DIAL SETTING	CONNECT VTVM	ADJUST	REMARKS
4. .01MFD	High side to pin 5 (plate) of 6BZ6 (V1). Low side to chassis.	10.7MC (Unmod)	FM	Low freq. end of dial.	DC probe thru 1Meg to point $\text{\textcircled{A}}$. Common to chassis.	A10, A11, A12, A13, A14	Adjust for maximum deflection.
5. "	"	"	"	"	DC probe to point $\text{\textcircled{B}}$. Common to chassis.	A15	Adjust for zero reading. A positive and negative reading will be obtained on either side of the correct setting. Repeat steps 4 and 5.

FM IF ALIGNMENT USING FM SIGNAL GENERATOR AND OSCILLOSCOPE

DUMMY ANTENNA	SIGNAL GENERATOR COUPLING	SIGNAL GENERATOR FREQUENCY	BAND SWITCH POS.	RADIO DIAL SETTING	CONNECT SCOPE	ADJUST	REMARKS
4. .01MFD & 1000 Ω in series	High side to pin 5 (plate) of 6BZ6 (V1). Low side to chassis.	10.7MC (300KC Swp)	FM	Low freq. end of dial	Vert. Amp. thru 1Meg to point $\text{\textcircled{A}}$. Low side to chassis.	A10, A11, A12, A13, A14	Disconnect stabilizing capacitor C2. Adjust for curve of maximum amplitude and symmetry similar to Fig. 1.
5. "	"	"	"	"	Vert. Amp. thru 100K to point $\text{\textcircled{B}}$. Low side to chassis.	A15	Reconnect stabilizing capacitor C2. Adjust so that 10.7MC occurs at center of crossover lines similar to Fig. 2. SLIGHTLY retouch A14 for maximum amplitude and straightness of crossover lines. Repeat steps 4 and 5.

FM RF ALIGNMENT

DUMMY ANTENNA	SIGNAL GENERATOR COUPLING	SIGNAL GENERATOR FREQUENCY	BAND SWITCH POS.	RADIO DIAL SETTING	CONNECT VTVM	ADJUST	REMARKS
6. 120 Ω & 150 Ω carbon resistors	High side thru 120 Ω to FM antenna terminal, Low side thru 150 Ω to chassis.	106MC	FM	106MC	DC probe thru 1Meg to point $\text{\textcircled{A}}$. Common to chassis.	A16, A17, A18	Adjust for maximum deflection.
7. "	"	90MC	"	90MC	"	A19	Adjust for maximum deflection. Repeat steps 6 and 7.

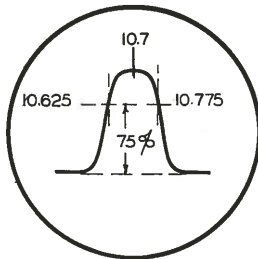

FIG. 1

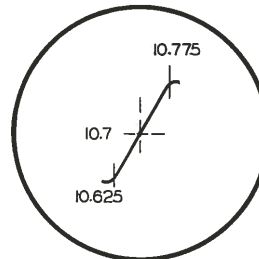
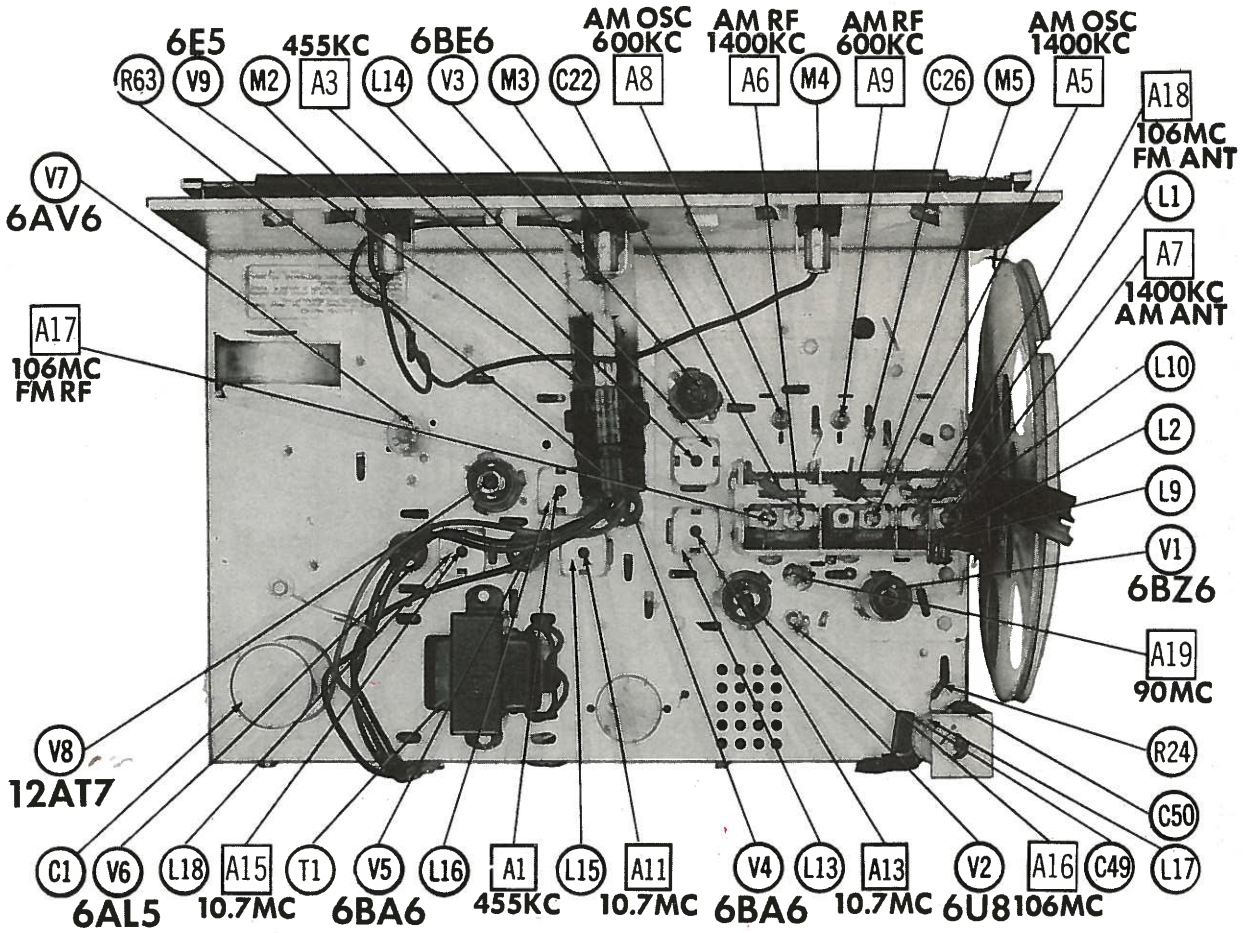

FIG. 2

CHASSIS—TOP VIEW



PARTS LIST AND DESCRIPTIONS TUBES (GENERAL ELECTRIC, SYLVANIA)

ITEM No.	USE	TYPE	NOTES	ITEM No.	USE	TYPE	NOTES
V1	RF Amplifier	6BZ6		V6	Ratio Detector	6AL5	
V2	FM Mixer-Oscillator	6U8		V7	Phono Pre-amplifier	6AV6	
V3	AM Converter	6BE6		V8	AF Amp. - Cath. Follower	12AT7	
V4	1st. IF Amplifier	6BA6		V9	Tuning Indicator	6E5	
V5	2nd. FM IF Amplifier	6BA6					

ELECTROLYTIC CAPACITORS

ITEM No.	RATING CAP.	VOLT.	REPLACEMENT DATA				SPRAGUE PART No.		
			MAGNAVOX PART No.	AEROVOX PART No.	CORNELL-DUBILIER PART No.	MAILORY PART No.		PYRAMID PART No.	SANGAMO PART No.
C1A	.30	450	270021-58	A7B2-54	EO430	FP237	TMD-52	D-285	TVL-2759
C1B	.30	450	270027-27	PBS150V4	BBR4-50	TC30	TD-4-50	MMT-0505	TVA-1303
C2	4	50	270027-28	SRE25V20	BBR20-25	TC26	TD-25-25	FM-0225	TVA-1205
C3	20	25	270027-28	SRE25V20	BBR20-25	TC26	TD-25-25	FM-0225	TVA-1205
C4	20	25	270027-28	SRE25V20	BBR20-25	TC26	TD-25-25	FM-0225	TVA-1205

FIXED CAPACITORS

Capacity values given in the rating column are in mfd. for Paper Capacitors, and in mmfd. for Mica and Ceramic Capacitors.

ITEM No.	RATING CAP.	VOLT.	REPLACEMENT DATA						NOTES	
			MAGNAVOX PART No.	AEROVOX PART No.	CENTRALAB PART No.	CORNELL-DUBILIER PART No.	ERIE PART No.	MAILORY PART No.		SPRAGUE PART No.
C5	.33	500	250187-47	1489-000033	DD-502	5B5Q83	GP-5000	MCB235	MB-433	Note 1
C6	100	500	250187-53	1489-0001	DD-502	5B5T1	GP-5000	DCS25	MB-31	
C7	5000	500	250176-1	BFD-005	DD-502	BYA0D5	GP-5000	DCS25	5HK-D5	
C8	5000	500	250176-1	BFD-005	DD-502	BYA0D5	GP-5000	DCS25	5HK-D5	
C9	5000	500	250176-1	BFD-005	DD-502	BYA0D5	GP-5000	DCS25	5HK-D5	
C10	100	500	250176-1	BFD-005	DD-502	5B5T1	GP-5000	MCB235	MB-31	
C11	2.2	500	250221-118	NFD-512.2	TCZ-2R2	CI072C	TCO-2.2	DCS25	5TCCB-V22	
C12	5000	500	250176-1	BFD-005	DD-502	BYA0D5	GP-5000	DCS25	5HK-D5	
C13	5000	500	250176-1	BFD-005	DD-502	BYA0D5	GP-5000	DCS25	5HK-D5	
C14	5	500	250088-138	BFD-00022	DD-502	5W5T22	ED-220	UC-5322	1FM-322	
C15	220	500	250159-55	BFD-00022	DD-502	5W5T22	ED-220	UC-5322	1FM-322	
C16	220	500	250159-55	BFD-00022	DD-502	5W5T22	ED-220	UC-5322	1FM-322	
C17	0.047	400	250211-5	BFD-0047	DD-472	CU36D47	GP-5000	GSM-4247	6TM-D47	
C18	5000	500	250176-1	BFD-005	DD-502	5W5T22	GP-5000	UC-5322	5HK-D5	
C19	220	500	250188-57	1488-00022	DD-221	5W5T22	GP-5000	UC-5322	1FM-322	
C20	1	200	250202-13	P28RN-1	DF-104	CU32P1	GP-5000	GSM-201	2TM-P1	
C21	5000	500	250176-1	BFD-005	DD-502	BYA0D5	GP-5000	DCS25	5HK-D5	
C22	20	500	250187-5	1489-00002	DD-502	5B5Q2	GP-5000	DCS25	MB-43	
C23	5000	500	250176-1	BFD-005	DD-502	BYA0D5	GP-5000	DCS25	5HK-D5	
C24	5000	500	250176-1	BFD-005	DD-502	BYA0D5	GP-5000	DCS25	5HK-D5	
C25	47	500	250187-49	1489-00047	DD-502	5B5Q47	GP-5000	DCS25	MB-447	
C26	20	500	250187-5	1489-00002	DD-502	5B5Q2	GP-5000	DCS25	MB-43	
C27	5000	500	250176-1	BFD-005	DD-502	BYA0D5	GP-5000	DCS25	5HK-D5	
C28	3500	500	250176-28	BFD-0033	DD-332	BYA0D33	GP-3500	UC-5333	5GA-D33	
C29	10000	500	250218-19	BFD-001	DD-103	BYA0D1	GP-10000	DCS1	5HK-S1	
C30	5000	500	250176-1	BFD-005	DD-502	BYA0D5	GP-5000	DCS25	5HK-D5	
C31	5000	500	250176-1	BFD-005	DD-502	BYA0D5	GP-5000	DCS25	5HK-D5	
C32	5000	500	250176-1	BFD-005	DD-502	BYA0D5	GP-5000	DCS25	5HK-D5	
C33	5000	500	250176-1	BFD-005	DD-502	BYA0D5	GP-5000	DCS25	5HK-D5	
C34	330	500	250207-49	BFD-00033	DD-331	LI0733	ED-330	UC-5333	5GA-T33	
C35	330	500	250207-49	BFD-00033	DD-331	LI0733	ED-330	UC-5333	5GA-T33	
C36	3300	500	250176-28	BFD-0033	DD-332	BYA0D33	GP-3300	UC-5333	5GA-T33	
C37	220	220	250218-5	BFD-0022	DD-221	LI0722	ED-220	UC-5322	5GA-T22	
C38	220	220	250218-5	BFD-0022	DD-221	LI0722	ED-220	UC-5322	5GA-T22	
C39	1000	1000	250218-22	BFD-001	DD-102	BYA0D1	ED-1000	DCS21	5HK-D1	
C40	100	1000	250218-22	BFD-001	DD-101	LI071	ED-100	UC-531	5GA-T1	
C41	330	330	250207-49	BFD-00033	DD-331	LI0733	ED-330	UC-5333	5GA-T33	
C42	10000	10000	250218-19	BFD-001	DD-103	BYA0D1	GP-10000	DCS1	5HK-S1	
C43	1500	1500	250218-18	BPD-00015	DD-152	LI0715	ED-1500	UC-5315	5GA-T15	
C44	220	220	250218-22	BPD-00022	DD-221	LI0722	ED-220	UC-5322	5GA-T22	
C45	68	68	250218-7	1750-51 68	TCN-68	CI06Q88U	TCY-68	UC-5433	5TCU-Q68	
C46	33	33	250218-5	BPD-000033	DD-330	LI0733	ED-33	UC-5333	5GA-Q33	
C47	220	220	250218-5	BPD-00022	DD-221	LI0722	ED-220	UC-5322	5GA-T22	
C48	220	220	250218-5	BPD-00022	DD-221	LI0722	ED-220	UC-5322	5GA-T22	
C49	1000	1000	250228-354	1464-001	DD-221	1DR5D1	ED-220	MCE255	MS-21	
C50	1000	1000	250228-354	1464-001	DD-221	1DR5D1	ED-220	MCE255	MS-21	

PARTS LIST AND DESCRIPTIONS (Continued)

CAPACITORS (cont)

ITEM No.	RATING		REPLACEMENT DATA								NOTES
	CAP.	VOLT	MAGNAVOX PART No.	AEROVOX PART No.	CENTRALAB PART No.	CORNELL-DUBILIER PART No.	ERIE PART No.	MALLORY PART No.	SPRAGUE PART No.		
C51	1000	500	250228-354	1464-001		IDR5D1		MCE255	MS-21		
C52	22		250218-1	BPD-00022	DD-202	L10Q22	ED-22	UC-5422	5GA-Q22		
C53	5000		250175-30	BPD-005	DD-502	BYA10D5	GP-5000	DC525	5HK-D5		
C54	10000		250218-19	BPD-01	DD-103	BYA681	GP-10000	DC511	5HK-S1		
C55	100		250218-22	BPD-0001	DD-101	L10T1	ED-100	UC-531	5GA-T1		
C56	680		230218-4	BPD-00068	DD-681	BYA10T68	ED-680	UC-5368	5GA-T68		
C57	1000	500	250228-354	1464-001		IDR5D1		MCE255	MS-21		
C58	10000		250218-19	BPD-01	DD-103	BYA681	GP-10000	DC511	5HK-S1		
C59	5000		250175-30	BPD-005	DD-502	BYA10D5	GP-5000	DC525	5HK-D5		
C60	5000		250175-30	BPD-005	DD-502	BYA10D5	GP-5000	DC525	5HK-D5		
C61	470		250175-8	BPD-00047	DD-471	BYA10T47	ED-470	UC-5347	5GA-T47		
C62	5000		250175-1	BPD-005	DD-502	BYA681	GP-5000	DC525	5HK-D5		
C63	.1	200	250202-13	P288N-1	DF-104	CUB2P1		GEM-401	2TM-P1		
C64	5000		250175-1	BPD-005	DD-502	BYA10D5	GP-5000	DC525	5HK-D5		
C65	5000		250175-1	BPD-005	DD-502	BYA10D5	GP-5000	DC525	5HK-D5		
C66	5000		250175-1	BPD-005	DD-502	BYA10D5	GP-5000	DC525	5HK-D5		
C67	10000		250218-19	BPD-01	DD-103	BYA681	GP-10000	DC511	5HK-S1		

Note 1. Some versions may use 33MMF in this application (Part #250187-47).

CONTROLS

ITEM No.	RATING		REPLACEMENT DATA					INSTALLATION NOTES
	RESISTANCE	WATTS	MAGNAVOX PART No.	CENTRALAB PART No.	CLAROSTAT PART No.	IRC PART No.	MALLORY PART No.	
R1A	1Meg	1/2	220074-12		A47F3-1Meg	Q18-137X		Volume-tap @ 100K
B	Shaft	1/2			FS-3	Not Req.		
R2A	1Meg	1/2	220072-29	B-70	A47-1Meg-Z	Q13-137	U53	Trehle
B	Shaft	1/2		Not Req.	FS-3	Not Req.	U53	
R3A	1Meg	1/2	220073-20	AB-70	A47-1Meg-Z	Q13-137	U53	Bass
B	Shaft	1/2		AK-3	FS-3	Not Req.	Not Req.	
C	Switch			KB-1	SWE-12	76-1	US-26	

RESISTORS

All wattages 1/2 watt, or less, unless otherwise listed.

ITEM No.	RATING		REPLACEMENT DATA		NOTES
	OHMS	WATT	MAGNAVOX PART No.	IRC PART No.	
R4	22K		230104-78	BTS-22K	
R5	15K		230104-76	BTS-15K	
R6	100K		230104-86	BTS-100K	
R7	180Ω		230104-53	BTS-180	
R8	100K		230104-86	BTS-100K	
R9	68K		230104-84	BTS-68K	
R10	2700Ω		230104-67	BTS-2700	
R11	1000Ω		230104-62	BTS-1000	
R12	10K	2	230096-74	BTS-10K	
R13	4700Ω		230104-70	BTS-4700	
R14	1Meg		230104-98	BTS-1Meg	
R15	1000Ω	2	230096-62	BTS-1000	
R16	100Ω		230104-50	BTS-100	
R17	22K		230104-78	BTS-22K	
R18	15K	2	230096-76	BTS-15K	
R19	1000Ω		230104-62	BTS-1000	
R20	2.2Meg		230104-102	BTS-2.2Meg	
R21	8200Ω	5	240071-13	PW10-8200	
R22	68Ω		230104-48	BTS-68	
R23	1Meg		230104-98	BTS-1Meg	
R24	220K		230104-90	BTS-220K	
R25	150K 5%		230104-88	BTS-150K 5%	
R26	47K		230104-82	BTS-47K	
R27	47K		230104-82	BTS-47K	
R28	220K		230104-90	BTS-220K	
R29	2.2Meg		230104-102	BTS-2.2Meg	
R30	1.5Meg		230104-100	BTS-1.5Meg	
R31	47K		230104-82	BTS-47K	
R32	22K		230104-78	BTS-22K	
R33	1000Ω		230104-62	BTS-1000	
R34	68Ω		230104-48	BTS-68	

PARTS LIST AND DESCRIPTIONS (Continued)

TRANSFORMER (FILAMENT)

ITEM No.	RATING				REPLACEMENT DATA					
	PRI.	SEC. 1	SEC. 2	SEC. 3	MAGNAVOX PART No.	Halderson PART No.	Merit PART No.	Stancor PART No.	Thordarson PART No.	Triad PART No.
T1	117VAC ④.28A	6.3VAC ④3.2A			320258-2 ①	F5512 ②	P-2947 ③	P-8488 ④	21F10 ⑤	F-18X ⑥

- ① Alternate part #320258-1.
- ② Tape center tap on secondary winding.
- ③ Fabricate mounting.

COILS (RF-IF)

ITEM No.	USE	REPLACEMENT DATA				NOTES
		MAGNAVOX PART No.	MEISSNER PART No.	MERIT PART No.	MILLER PART No.	
L1	FM Ant. Trans.	360491-3				
L2	FM Ant. Coil	380656-1				
L3	RF Choke	380522-9	19-1002		4606	2 Microhenries
L4	FM RF Coil	380828-1				
L5	Fl. Choke	380522-9	19-1002		4606	2 Microhenries
L6	Fl. Choke	380522-9	19-1002		4606	2 Microhenries
L7	FM Osc. Coil	380828-1				
L8	AM Loop Stick	480894-3				
L9	RF Choke	380522-9	19-1002			162 Microhenries
L10	RF Choke	380522-9	19-1002		4606	2 Microhenries
L11	AM-RF Coil	380348-2				A-5495-RF
L12	AM-Osc. Coil	380407-2	14-1033			
L13	1st. FM IF	380626-1	16-3487	FM-254	1463	
L14	1st. AM IF	380611-1	16-6758	BC-352	12-C1	
L15	2nd. FM IF	380626-1	16-3487	FM-254	1463	
L16	2nd. AM IF	380626-1	16-6770	BC-355	12-C8	
L17	10K Filter	380621-1				
L18	Ratio Det.	380627-1	17-3498	FM-255	1465	

CRYSTAL DIODES

ITEM No.	ORIG. TYPE	REPLACEMENT DATA		NOTES
		MAGNAVOX PART No.	SYLVANIA PART No.	
M1	1N34A	530030-3	1N34A	Audio Detector (Pigtail)

MISCELLANEOUS

ITEM No.	PART NAME	MAGNAVOX PART No.	NOTES
M2	Dial Light	180161-17	#1847
M3	Dial Light	180161-17	#1847
M4	Dial Light	180161-17	#1847
M5	Tuning Cap.	260137-1	6 Gang (AM Sections: 30-550MMF, 24-525MMF, 16-190MMF)
M6	Switch	160265-1	Bandswitch (Rotary-wafer type) 2 gang
M7	Switch	160265-3	Selector (Rotary-wafer type)
	Glass Pointer	157428-1	
		102448-1	

GENERAL

Model CR-730 is an AM-FM tuner designed to operate in conjunction with a separate audio amplifier. Heater voltages are supplied by a heater transformer mounted on the chassis, however, plate voltages are obtained from the power supply of the associated power amplifier. It is therefore essential that the radio and amplifier chassis be inter-connected during alignment or for other electrical service operations.

After production is started on a unit, it is often necessary to make electrical or mechanical changes in it. These are indicated by a difference in the suffix letters. The original chassis will bear the suffix "AA". A circuit change is indicated by the first suffix letter; for example, CR-500BA. A mechanical change is indicated by the second suffix letter; for example, CR-500AB.

SPECIFICATIONS

Tuning frequency range:

Broadcast band 540-1620 KC

FM band 88-108 MC

Intermediate frequency . .455 KC/10.7 MC

Tubes:

R-F amplifier 6BZ6

FM mixer-oscillator 6U8

AM mixer-oscillator	6BE6
I-F amplifier	6BA6
FM driver	6BA6
Ratio detector	6AL5
AM detector (crystal diode) .	1N34A
Phono pre-amp	6AV6
1st audio amp	($\frac{1}{2}$) 12AT7
Cathode follower	($\frac{1}{2}$) 12AT7
Tuning indicator	6E5

DIAL STRINGING

DIAL CORD PLACEMENT

Select a 48 inch length of dial cord and tie a small loop at each end. Turn the tuning gang fully out of mesh and hook one end of the cord over the metal hook on the condenser pulley nearest the front of the chassis and proceed with the stringing as shown in the drawing below.

DIAL POINTER PLACEMENT

Place the dial pointer onto the pointer slide and turn the tuning gang completely in mesh. Lace the dial cord around the three hooks on the front of the pointer and with the tuning condenser still fully in mesh, slide the pointer over until it lines up with the last dial calibration mark at the low frequency end of the broadcast band. This completes the assembly.

