

28 28

SERVICE **1030**
MANUAL



marantz

model 1030

console *Stereo* amplifier

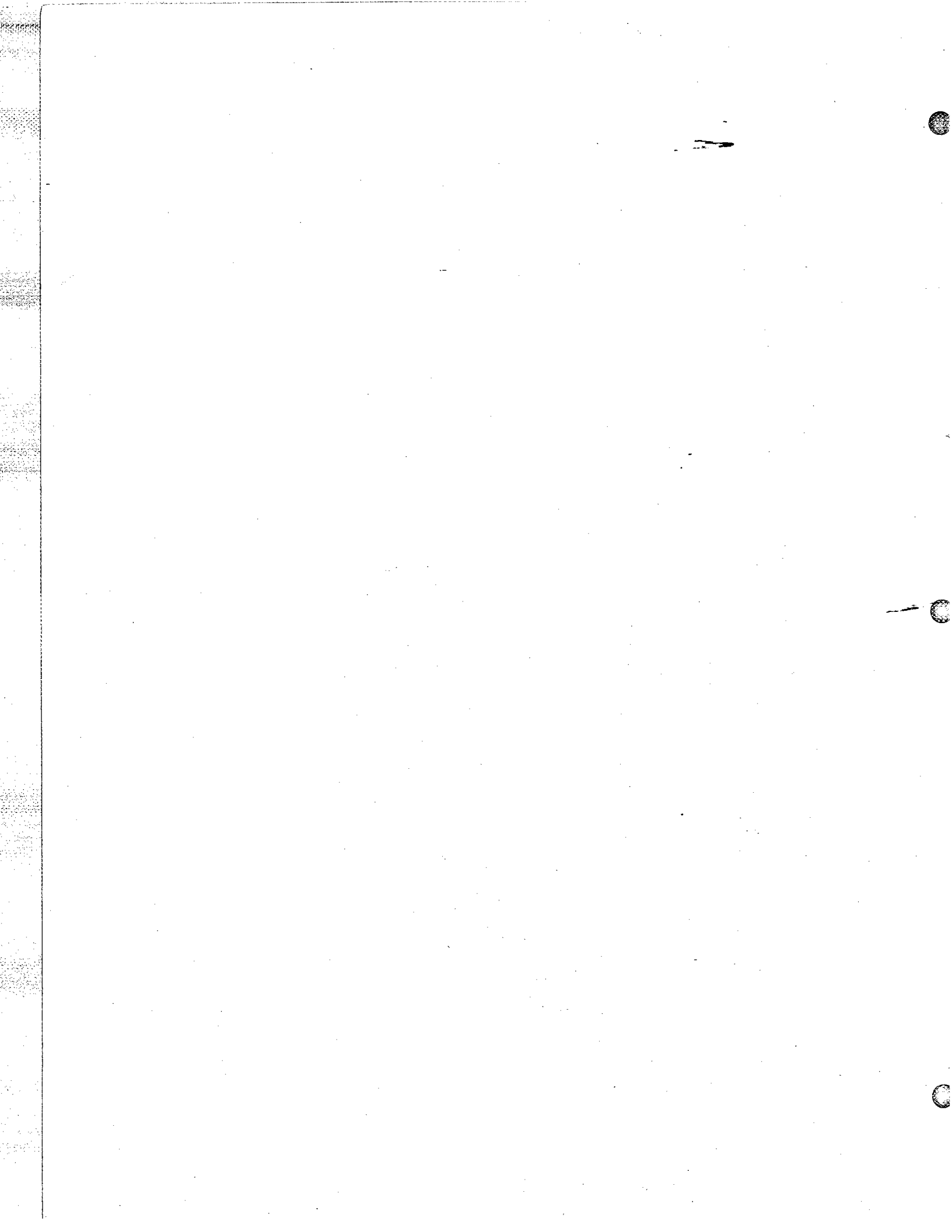

TABLE OF CONTENTS

SECTION	PAGE
Introduction	1
Pre-amplifier	1
Main Amplifier	1
Power Supply Unit	1
Trouble Analysis	2
Power Amplifier Adjustment	2
Performance Verification	2
Test Equipment Required for Servicing	5
Voltage Conversion	6
Parts List	14
Specifications	18

LIST OF ILLUSTRATIONS

FIGURE	PAGE
1. AC Power Control Box Simplified Schematic	4
2. Amplifier Output Load Box Simplified Schematic	4
3. Remove the Terminal Cover	6
4. Voltage Conversion Chart	7
5. Front Panel Adjustment and Component Locations	8
6. Main Chassis Component Locations (Top View)	8
7. Rear Panel Adjustment and Component Locations	9
8. Main Chassis Component Locations (Bottom View)	9
9. Phono Amplifier Assembly P900 Component Locations	10
10. Tone and Pre Amplifier Assembly P500 Component Locations	10
11. Tone Control Volume Unit Assembly P650 Component Locations	11
12. Main, Remoto, High and Low Filtier Switch Unit Assembly P300 P300 Component Locations	11
13. Loudness, Tape Moni. and Mono Switch Unit Assembly P600 Component Locations	12
14. Power Amplifier Assembly P700 Component Locations	12
15. Power Supply Assembly P800 Component Locations	12
16. Schematic Diagram	13

1. INTRODUCTION

This service manual was prepared for use by Authorized Warranty Stations and contains service information for Marantz Model 1030 Stereo Console Amplifier.

Servicing information and voltage data included in this manual are intended for use by the knowledgeable and experienced technician only. All instruction should be read carefully. No attempt should be made to proceed without a good understanding of the operation in the circuits.

The part lists furnish information by which replacement part may be ordered from the Marantz Company. A simple description is included for parts which can be usually be obtained through local suppliers.

2. PRE-AMPLIFIER

Signals from the input jacks (TUNER, TAPE, AUX) are applied to the selector switch.

Signals from the PHONO jacks or MIC jack are applied to the other section of the selector switch, then, led to the phono-amplifier and equalized to match the RIAA curve for flat frequency response. The gain of the phono-amplifier consisting of direct coupled circuit (H901 and H903) is 38 dB.

The outputs of the phono-amplifier are led to the selector switch. The selector switch selects one of signals from PHONO, MIC, TUNER, or AUX jacks and send it to the TAPE MONITOR switch and TAPE OUT jacks. The selected signals are then applied to the balance and volume controls, then to the pre-amplifier consisting of H501, H503 and H505 through Mono switch.

The frequency response is varied by the Bass and Treble controls, and the resultant output are led to PRE OUT jacks through High-cut and Low-cut filter networks. These networks are switched in and out from the circuit by the push-switches.

3. MAIN AMPLIFIER

Transistor H701 is a pre-driver coupled to the transistor H703 through capacitor C711. Transistor H703 drives the inverter transistors H709 and H711 which, in turn, drive the power stage consisting of H001 and H002. Transistors H705 and H707 are current limiters operating as a power protection circuits.

Excessive currents flowing into the power stage are detected by the resistors R741 and R/45 and the resultant variations are applied to the transistors H705 and H707 and make them turned on. This decreases the current flowing into the H709 and H711. In this way the currents flowing in the power stage (H001 and H002) are restricted within a safe value.

4. POWER SUPPLY UNIT

This power supply unit consisting of a transistor H801, which operates as a ripple filter, provides +35V DC to the Phono-amplifier and +27V DC to the Tone Amplifier.

5. TROUBLE ANALYSIS

1. Excessive line consumption
 - a. Check for shorted H007, H802, H803.
 - b. Check for shorted transistor H001 through H004.
Check L001 for short
2. No line consumption or zero bias
 - a. Check line cord, fuse, shorted H005, H006, H713, H714.
 - b. Check for open rectifiers H007 H802, H803.
3. High hum and noise level
 - a. Check filter capacitors C005, C703, C704.
4. Parasitic oscillation
 - a. Check for defective C705, C706, C713, C714, C723, C724, C727, C728.
5. Improper clipping
 - a. Check for proper adjustment R723, R724.

6. POWER AMPLIFIER ADJUSTMENT

1. Connect a VTVM across the resistor R747 and adjust the trimming resistor R729 until the VTVM reads 7.5mV DC. For the other channel connect the VTVM across the R748 and adjust the R730 for the same reading.
2. Connect a oscilloscope across the speaker terminals. Apply an audio signal of 1 KHz to the AUX jacks and increase the audio signal until the audio output on the scope begin to clip. Adjust the trimming resistor R723 for equal and symmetrical clipping. For the other channel adjust the R724.

7. PERFORMANCE VERIFICATION

Test Procedure

A. Test Equipment

Refer to Table 1 for required test equipment.

B. Preliminary Procedures.

1. Make the test setup shown in Figure 1 with the instrument controls set in the following positions:

Line Switch	off
Variable-line switch	variable
Watt Meter Switch	on
Variac	0 (fully CCW)
Load	8 ohms (0.5 mfd - off)
Audio Generator	Frequency 1KHz
Output	5V range
Gain Minimum	
AC Volt Meter	30V range
2. Make sure that connections between the resistive load and the system terminals of the Model 1030 have negligible resistance compared with the resistance of the load itself. Appreciable resistance in wiring adds to the total load, resulting in inaccurate measurements of output power.

3. Connect amplifier output to load and connect AC cord to line power. Connect a shorting plug to the Phono input jack of the model 1030.
4. Remove the top cover.

C. Total Hum and Noise Test

1. With shorting plugs connected to the Phono input jacks and a 8-ohm resistive load connected across the speaker system output terminals, connect a distortion analyzer across the load.

NOTE: In this test and tests that follow, if distortion analyzer used does not contain a built-in voltmeter, a VTVM may be substituted.

2. Set the distortion analyzer controls for voltage measurements and apply power to the amplifier. Set the volume control fully CCW. Set the SELECTOR switch to PHONO.
3. If the distortion analyzer indicates more than 2.5mV, refer to the trouble analysis section of this manual.
4. Set the volume control fully CW. If the distortion analyzer indicates more than 15mV refer to the trouble analysis section of this manual.

D. Maximum Power Output

1. Connect the audio oscillator to the AUX input. Set audio oscillator frequency to 1 KHz. Set SELECTOR switch to AUX.
2. With the distortion analyzer connected across the output load (8 ohms), set the analyzer on the 30V AC scale.
3. Turn the analyzer on and increase the audio oscillator output to 180mV, and verify the analyzer indicates more than 11V.

E. Harmonic Distortion Test

1. Set the frequency of the audio oscillator and the distortion analyzer to 20 KHz.
2. Set the controls of the analyzer for voltage measurement on the 30-volt scale.
3. Adjust the audio oscillator output level until the analyzer meter indicates 11 volts.
4. Switch the distortion analyzer to Set Level – Manual mode, and adjust SENSITIVITY for full scale reading on 0-1 scale.
5. Measure the total harmonic distortion with the analyzer and verify it is less than 0.5%.
NOTE: Any parasitic oscillation in the amplifier will be displayed on the oscilloscope when capacitance is switched into the load.
6. Switch the distortion analyzer back to SET LEVEL MANUAL.
(Do not adjust sensitivity of analyzer.)
7. Change the frequency of the audio oscillator and distortion analyzer to 1 KHz. Adjust audio oscillator output as necessary to have a full scale reading on the 0-1 scale on the analyzer.
8. Measure the distortion, verifying it is no greater than 0.5%.
9. Repeat steps 7 and 8, changing frequency to 40Hz.
Distortion should be no more than 0.5%.
10. Check for parasitic oscillations; there should be none.

F. Channel Separation

1. Set audio oscillator to 20 KHz. Connect oscillator to channel L AUX input only, with shorting plug (10K ohm) in channel R AUX input. Connect distortion analyzer to SPEAKER output terminals channel L.
2. Adjust oscillator output until distortion analyzer indicates 0 dB.
3. Measure channel R output. Distortion analyzer should indicate –30 dB or greater.
4. If indication is less than –30 dB, adjust input wires to preamp board until reading is –30 dB or greater.

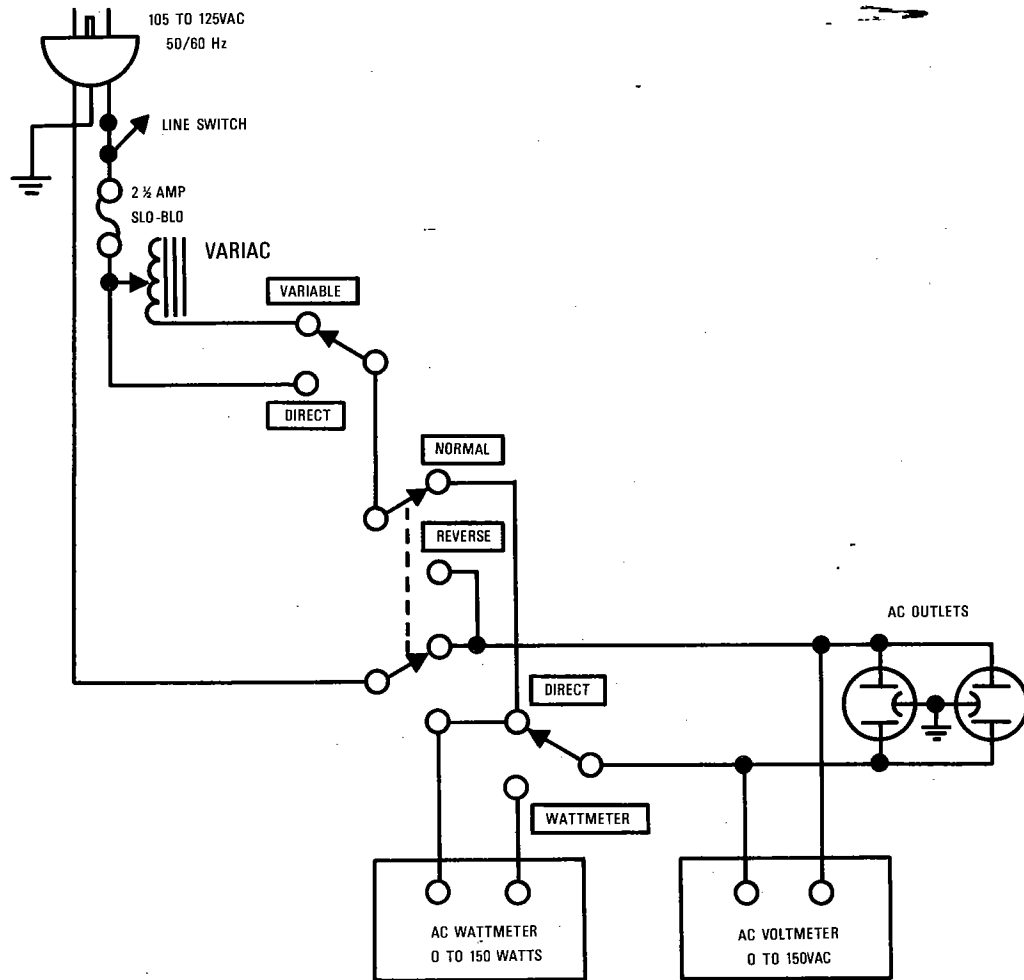

Figure 1. AC Power Control Box Simplified Schematic

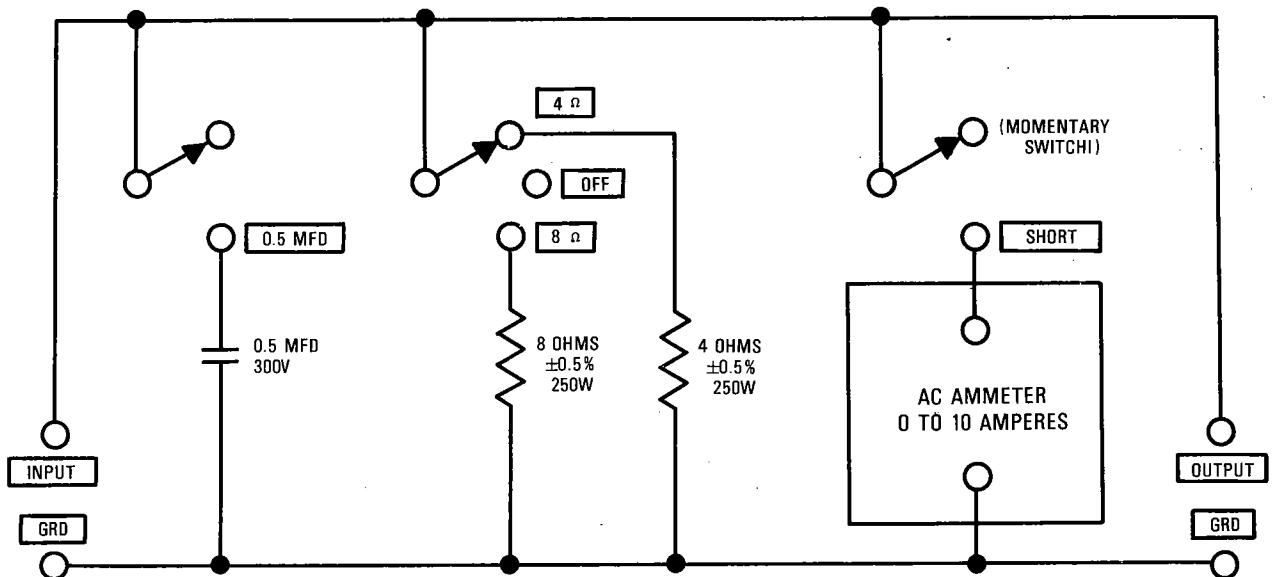

Figure 2. Amplifier Output Load Box Simplified Schematic

8. TEST EQUIPMENT REQUIRED FOR SERVICING

Table 1 lists the test equipment required for servicing the Model 1030 Stereo Console Amplifier. The wattmeter, ac voltmeter, and variac may be assembled as a test fixture as shown schematically in Figure 1, and the load resistors and ac ammeter may be assembled into a second test fixture as shown in Figure 2.

Item	Manufacturer and Model No. (or equivalent)	Use
Distortion Analyzer	Hewlett Packard, Model 331A or 333A	Measures distortion and voltage of amplifier output.
Audio Oscillator	Weston Model CVO-100P (NOTE: Less than 0.02 percent residual distortion is required.)	Sinewave and squarewave signal source.
Oscilloscope	Tektronix, Model 503; Data, Model 555	Waveform analysis and troubleshooting.
VTVM	RCA Senior Volt-Ohmyst, Model WV-98C	Voltage and resistance measurements.
AC Wattmeter	Simpson, Model 390	Monitors primary power consumption of amplifier.
AC Ammeter (0 to 10 amps)	Commercial Grade	Monitors amplifier output under short circuit condition.
Line Voltmeter (0 to 150 vac)	Commercial Grade	Monitors potential of primary power to amplifier.
Variable Autotransformer (0 to 140 vac, 10 amps)	Powerstat, Model 116B	Adjusts level of primary power to amplifier.
Shorting Plug	Use phono plug with 600 ohms across center pin and shell.	Shorts amplifier input to eliminate noise pickup.
Power Supply Bleeder Resistor (10 ohms at 1 W)	Commercial Grade	Discharges power supply filter capacitors prior to disassembly or resistance measurements.
Output Load Resistor ($8\Omega \pm 0.5\%$, 250W)	Commercial Grade	Provides 8-ohm load for amplifier output termination.
Output Load Resistor ($4\Omega \pm 0.5\%$, 250W)	Commercial Grade	Provides 4-ohm load for amplifier output termination.
Output Load Capacitor (0.5 mfd)	Mylar	Provides capacitive load for instability checks.
AC Power Control Box	Optional Item. Fabricate in accordance with Figure 1.	Monitors and controls primary power for amplifier.
Amplifier Output Load Box	Optional Item. Fabricate in accordance with Figure 2.	Provides various amplifier loads and can monitor shorted output.

9. VOLTAGE CONVERSION

This model is equipped with a universal power transformer to permit operation at 100, 120, 200, 220 and 240V AC 50 to 60Hz.

To convert the Model 1030 to the required voltage perform the following steps:

1. Remove the top cover.
2. Remove the Transformer Wire Connection Terminal Cover, loosen two Cover mounting screws on the rear panel. see Fig. 3.
3. Change the jumper wires as illustrated in Fig. 4 for the required AC voltage and replace the fuse as instructed.

CAUTION: DISCONNECT POWER SUPPLY CORD FROM AC OUTLET BEFORE CONVERTING VOLTAGE.

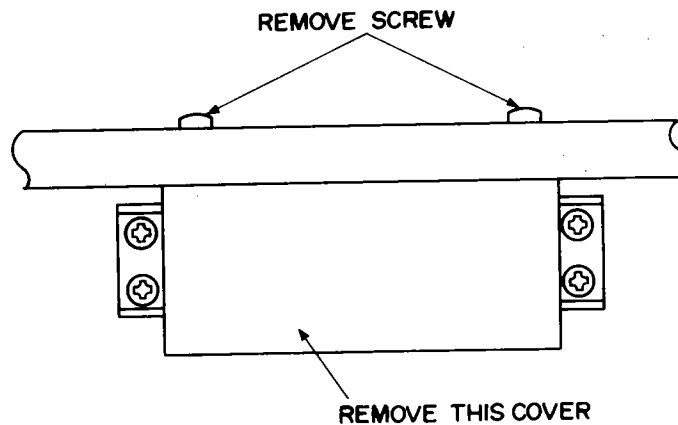
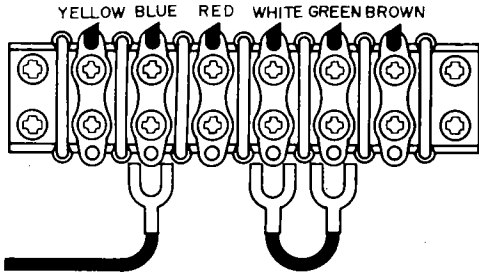
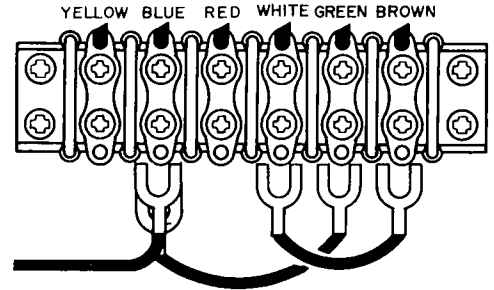

Figure 3. Remove the Terminal Cover

For 200V Operation
(Use 1 A Fuse)



For 100 V Operation
(Use 2 A Fuse)



For 220 V Operation
(Use 1 A Fuse)

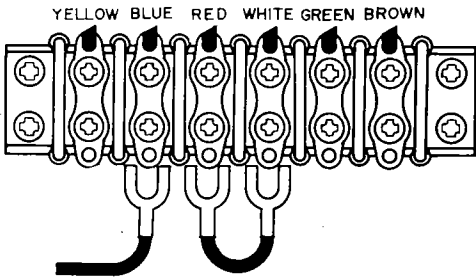

For 120 V Operation
(Use 1,5A Fuse)

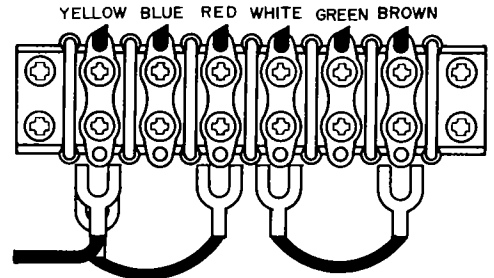

For 240V Operation
(Use 1A Fuse)

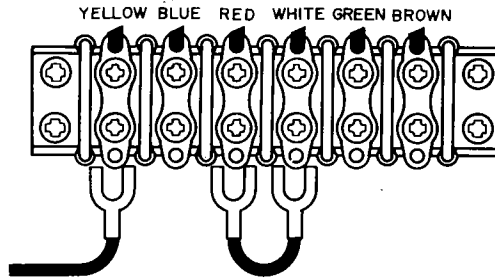

Figure 4. Voltage Conversion Chart

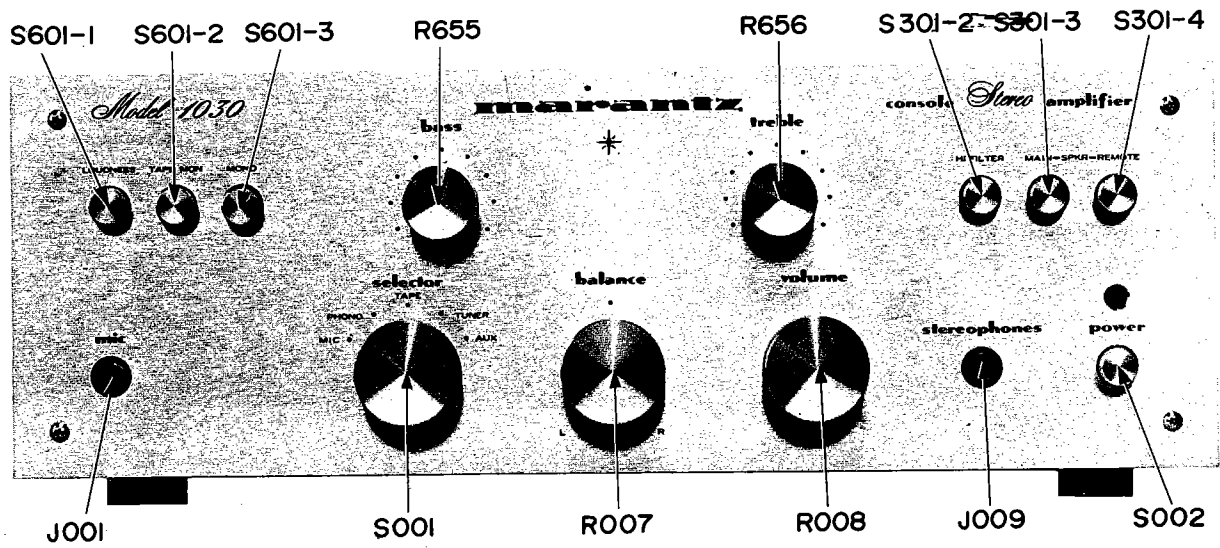

Figure 5. Front Panel Adjustment and Component Locations

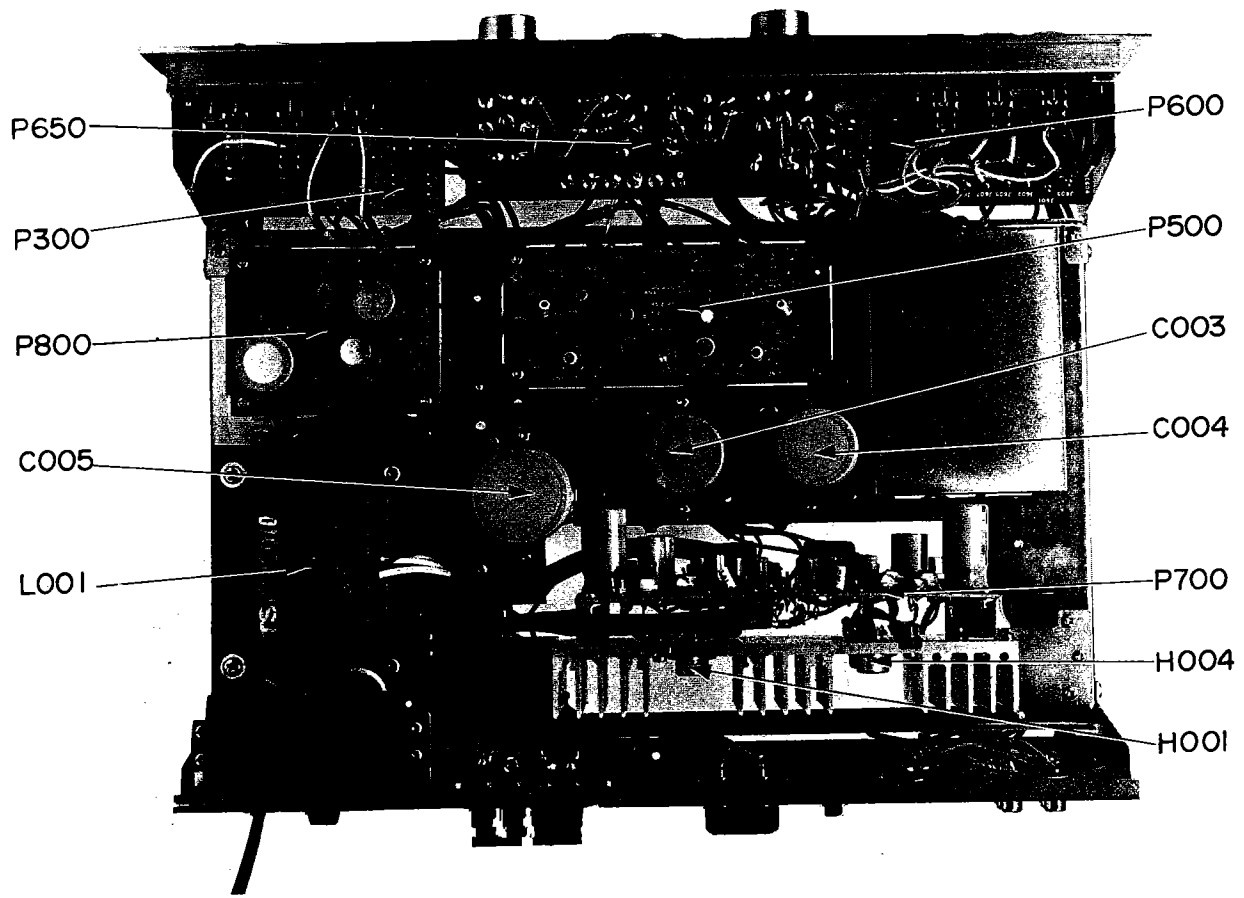

Figure 6. Main Chassis Component Locations (Top View)

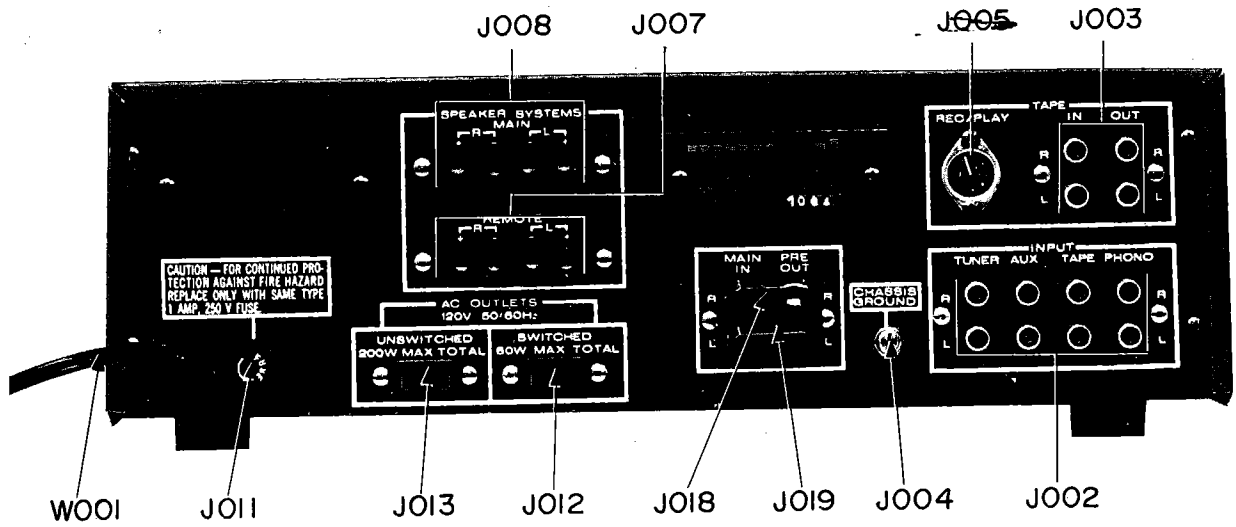

Figure 7. Rear Panel Adjustment and Component Locations

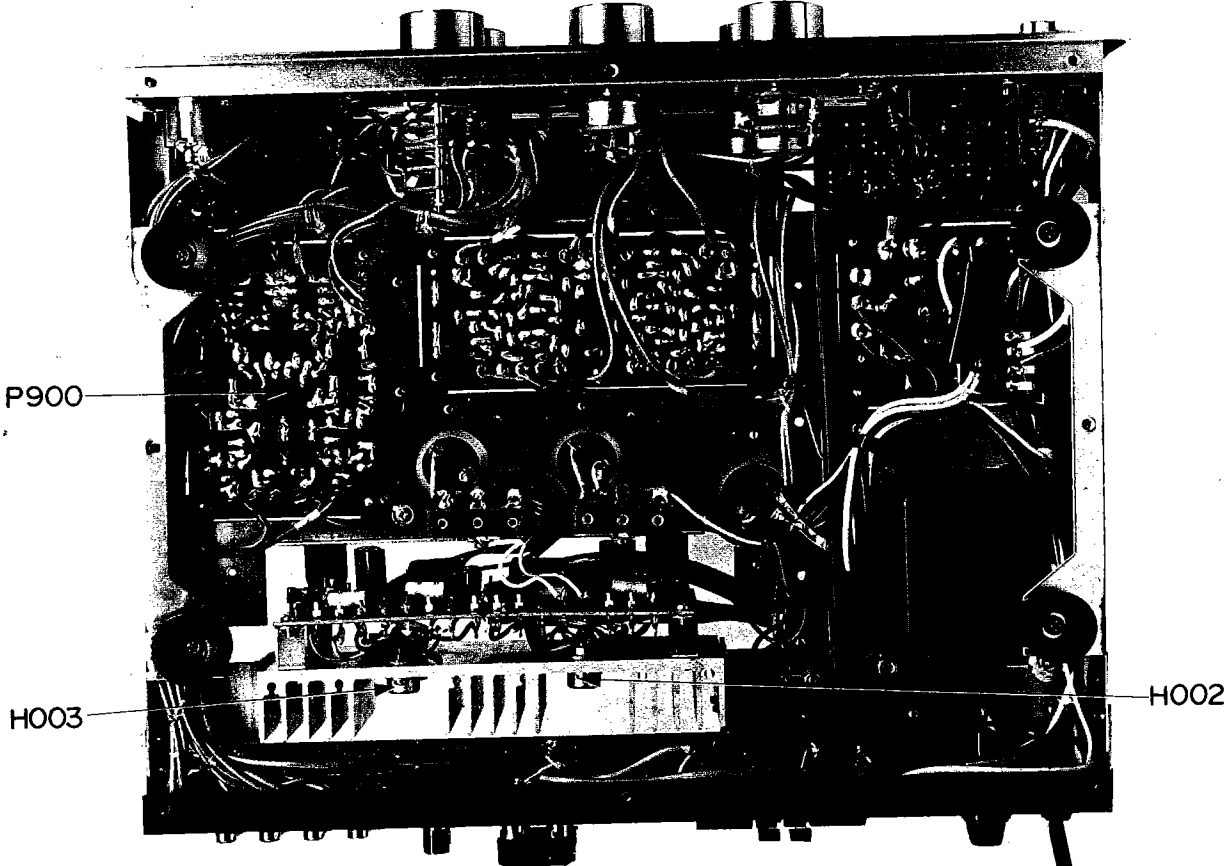

Figure 8. Main Chassis Component Locations (Bottom View)

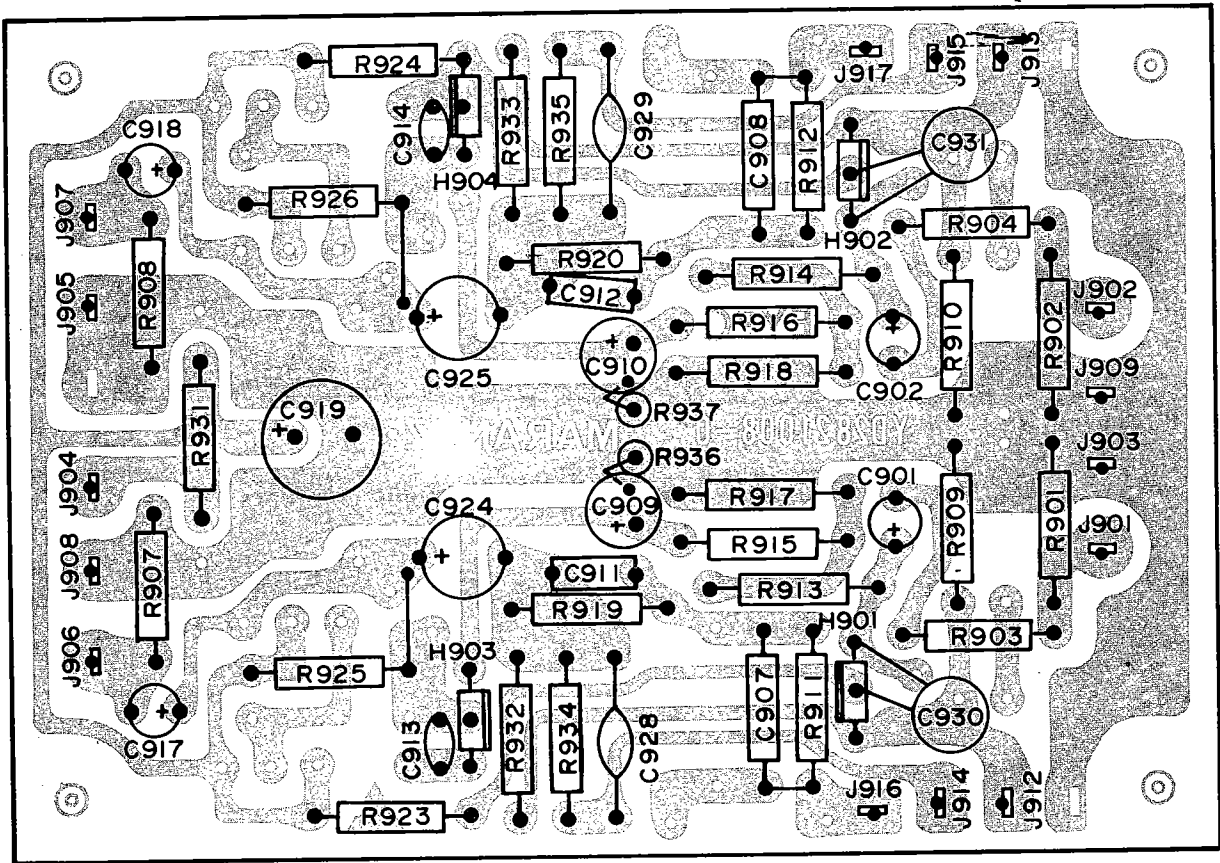

Figure 9. Phono Amplifier Assembly P900 Component Locations

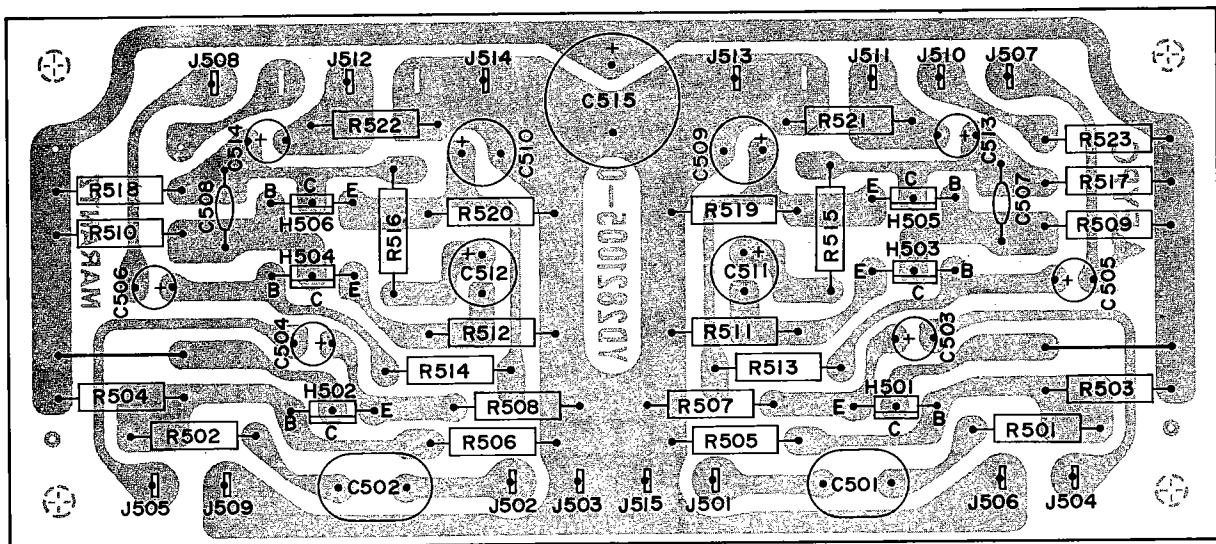

Figure 10. Tone and Pre Amplifier Assembly P500 Component Locations

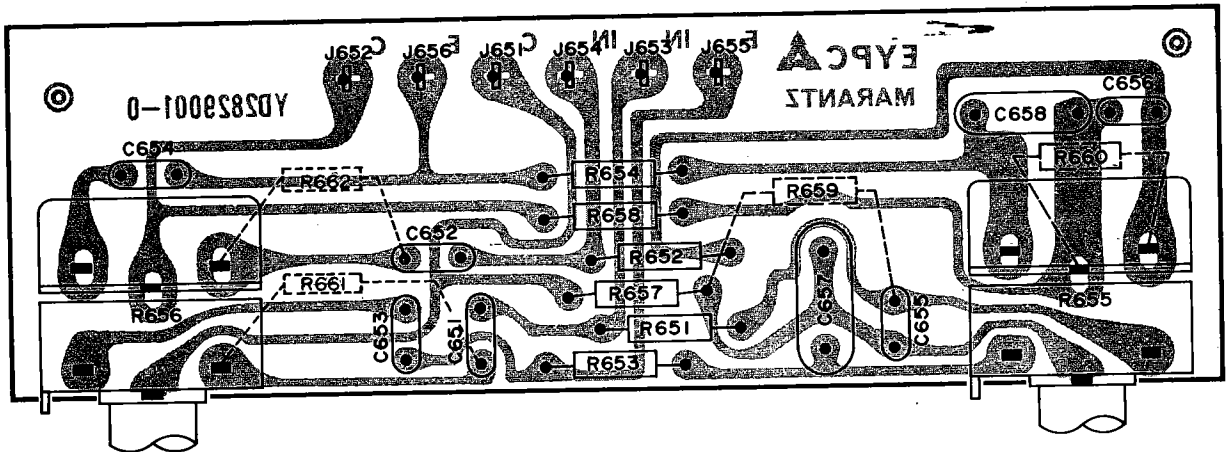

Figure 11. Tone Control Volume Unit Assembly P650 Component Locations

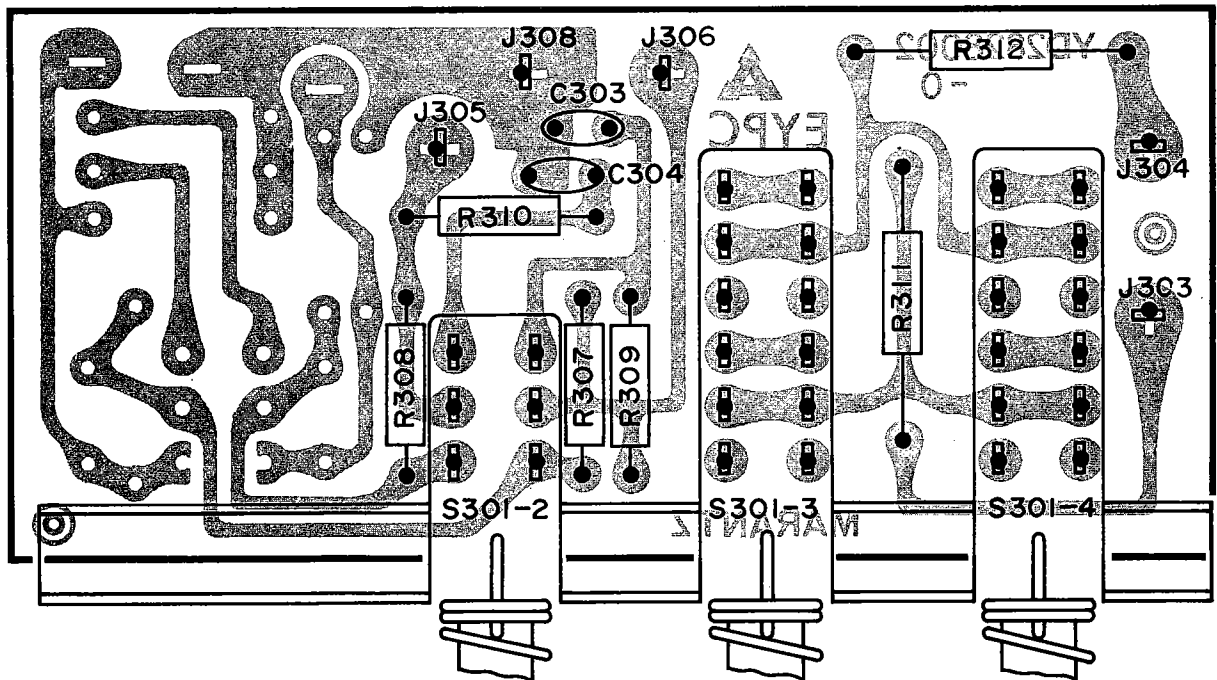

Figure 12. Main, Remoto, High and Low Filter Switch Unit Assembly P300 Component Locations

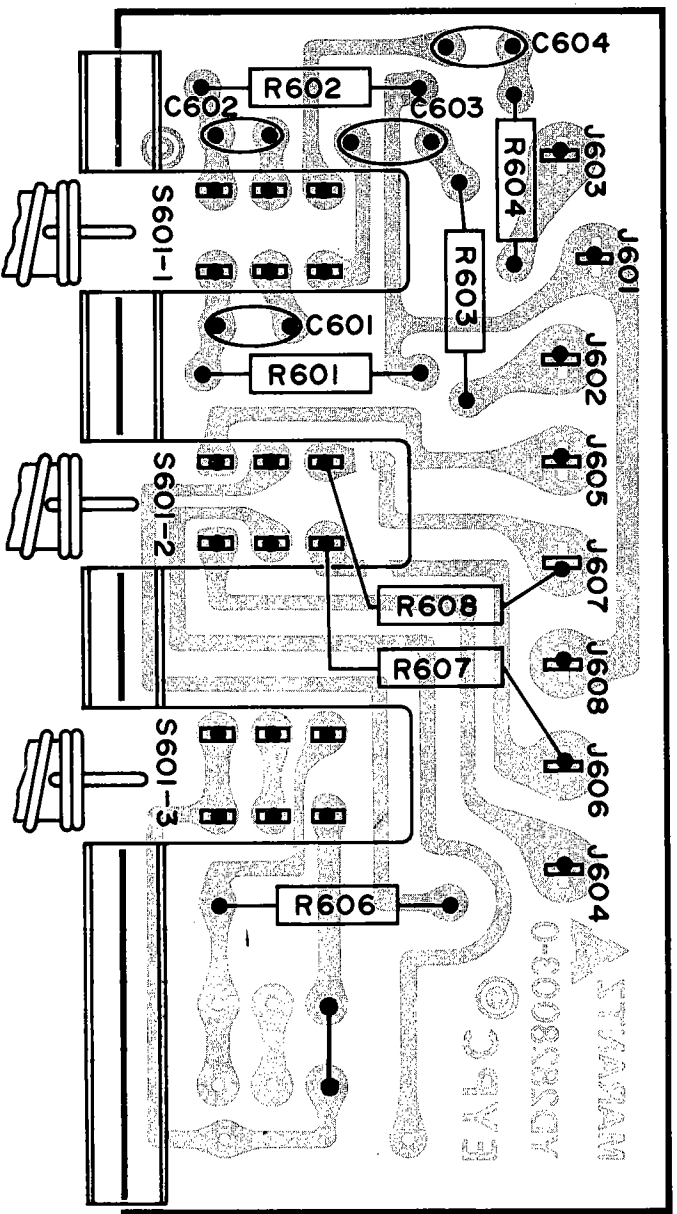

Figure 13. Loudness, Tape Moni. and Mono Switch Unit Assembly P600 Component Locations

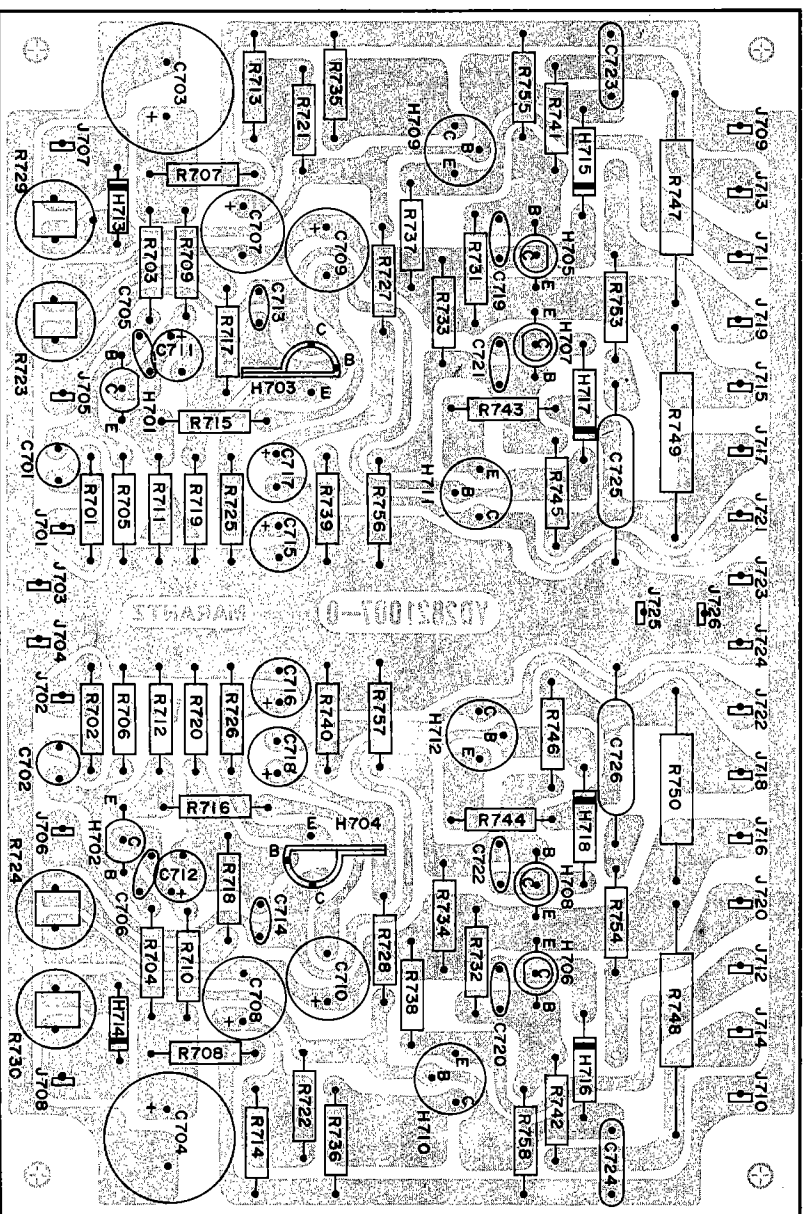

Figure 14. Power Amplifier Assembly P700 Component Locations

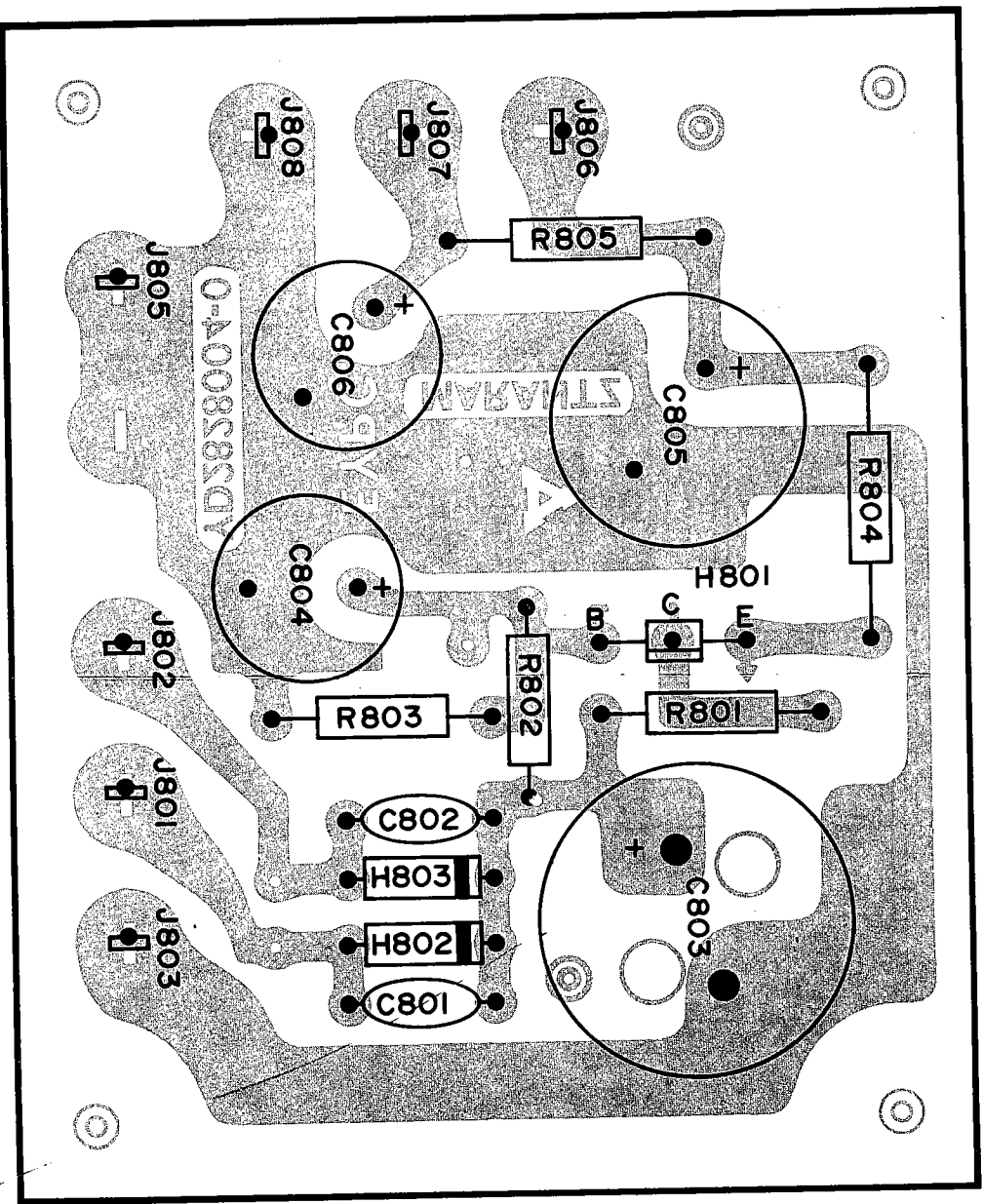

Figure 15. Power Supply Assembly P800 Component Locations

REF. DESIG.	MARANTZ PART NO.	DESCRIPTION	REF. DESIG.	MARANTZ PART NO.	DESCRIPTION
A	282906340	Frame assembly	0315	282112001	Insulator x 2
0102	282806301	Escutcheon	0316	282812003	Insulator
0121	257812001	Insulator x 2	0317	282111801	Spacer
0116	282805301	Cover	0319	257711806	Spacer x 4
0402	51122608E	T.H.M. screw x 4	0322	54010089R	Washer
B	282916040	Rear bracket assembly	0329	282711801	Spacer x 3
0130	282916001	Bracket	0402	51122608E	T H M screw x 4
J002	YT0208002	8P Terminal	0403	51100406S	B H M screw x 4
J003	YT0204003	4P Terminal x 2	0404	54020401S	Flat washer P x 4
J005	YJ1100001	Din socket	0406	51100406S	B H M screw x 8
J007-J008	YT0304002	4P SPKR terminal x 2	0407	54020401S	Flat washer P x 8
J012-J013	YT0400018	AC outlet x 2	0409	51570410B	P H tapt screw x 4
0432	51100308S	B H M screw x 2	0410	54020401E	Flat washer x 4
0505	55060307F	T R river x 4	0411	54040402N	Spring washer x 4
0103	282825701	Lid	0416	51570306B	P H tapt screw x 6
0104	282825702	Lid	0417	51570306B	P H tapt screw x 4
0105	282926501	Indicator	0418	51570306B	P H tapt screw x 4
0106	282926511	Indicator	0419	51570306B	P H tapt screw x 2
0109	282815401	Knob x 3	0420	51570312B	P H tapt screw x 4
0110	282815402	Knob x 2	0421	51570306B	P H tapt screw x 2
0111	281815401	Knob x 6	0426	51100306S	B H M screw x 4
0112	281815402	Knob	0427	51100306S	B H M screw x 2
0117	282905301	Cover	0428	51100306S	B H M screw x 2
0122	275905701	Leg x 4	0429	51100306S	B H M screw x 2
0123	281825905	Bush x 7	0430	51570312B	P H tapt screw x 4
0202	282810501	Chassis	0433	51100306E	B H M screw x 2
0204	282816050	Bracket K	0434	51100308S	B H M screw x 2
0209	282816003	Bracket	0501	51100308S	B H M screw x 2
0210	282816004	Bracket	0502	51100308S	B H M screw x 4
0213	282916004	Bracket x 4	0503	53110303E	Hexagon nut x 12
0214	282916002	Bracket	0506	54050300R	T L washer OR x 4
0215	282916003	Bracket	0507	53110403E	Hexagon nut
0216	282926701	Heat sink	0509	54050400R	T L washer OR
0217	282812001	Insulator	0510	54020401E	Flat washer P
0218	282812002	Insulator	0516	51570306B	P H tapt screw x 4
0219	282026702	Heat sink x 2	0517	51570306B	P H tapt screw x 4
0220	282910901	Shield	0518	51570308B	P H tapt screw x 2
0221	282816013	Bracket	0519	51570305B	P H tapt screw x 8
0222	282816014	Bracket	0526	51570306B	P H tapt screw x 10
0227	71400219Q	Spring	0527	51570306B	P H tapt screw x 8
0229	281812001	Insulator	0528	51570306B	P H tapt screw x 6
0230	276325901	Bush	0529	51570306B	P H tapt screw x 12
0232	318827102	Holder	0530	51570306B	P H tapt screw x 6
0301	138200503	Clamper x 8	0601	51570306B	P H tapt screw x 2
0302	273125302	Cover	0602	51570306B	P H tapt screw x 2
0303	202705501	Collar x 4	0603	51570306B	P H tapt screw
0304	282126902	Protector	0604	51570306B	P H tapt screw x 8
0305	281816006	Bracket	0605	51570306B	P H tapt screw x 2
0311	257711803	Spacer	0606	54050300R	T L washer OR x 15
0312	145525901	Bush	0610	54020501E	Flat washer P x 4
0313	250712001	Insulator	0611	54080400R	T L washer OR x 4
0314	273025901	Bush			

REF. DESIG.	MARANTZ PART NO.	DESCRIPTION
0612	53110403E	Hexagon nut x 4
0616	62031650W	Lug
0617	62031650W	Lug
0618	62031650W	Lug
0619	62031650W	Lug
0631	51570312B	P H tapt screw x 2
0632	54050300R	T L washer OR x 2
0633	53110303E	Hexagon nut x 2

REF. DESIG.	MARANTZ PART NO.	DESCRIPTION
P900	YD2821008 (ZZ2821008)	P.C. Board P.C. Board Assembly
RESISTORS		
R901-R902	RT0547314	Carbon, 47K Ω , $\pm 5\%$, 1/4W
R903-R904	RT1010214	Carbon, 1K Ω , $\pm 10\%$, 1/4W
R907-R908	RT0522414	Carbon, 220K Ω , $\pm 5\%$, 1/4W
R909-R910	RT0539114	Carbon, 390 Ω , $\pm 5\%$, 1/4W
R911-R912	RT0539414	Carbon, 390K Ω , $\pm 5\%$, 1/4W
R913-R914	GT0512412	Carbon, 120K Ω , $\pm 5\%$, 1/2W
R915-R916	RT0512214	Carbon, 1.2K Ω , $\pm 5\%$, 1/4W
R917-R918	RT0530114	Carbon, 300 Ω , $\pm 5\%$, 1/4W
R919-R920	RT0522314	Carbon, 22K Ω , $\pm 5\%$, 1/4W
R923-R924	GT0522412	Carbon, 220K Ω , $\pm 5\%$, 1/2W
R925-R926	RT0582214	Carbon, 8.2K Ω , $\pm 5\%$, 1/4W
R931	RT1010114	Carbon, 100 Ω , $\pm 10\%$, 1/4W
R932-R933	RN1033514	Carbon, 3.3M Ω , $\pm 10\%$, 1/4W
R934-R935	RT0533314	Carbon, 33K Ω , $\pm 5\%$, 1/4W
R936-R937	RT0510114	Carbon, 100 Ω , $\pm 5\%$, 1/4W
CAPACITORS		
C901-C902	EV2250251	Elect., 2.2 μ F, +40%, -20%, 25V
C907-C908	DF1610301	Mylar, 0.01 μ F, $\pm 10\%$
C909-C910	ED1070061	Elect., 100 μ F, 6.3V
C911-C912	DF1633201	Mylar, 0.0033 μ F, $\pm 10\%$
C913-C914	DD1650001	Ceramic, 50pF, $\pm 10\%$, 50V
C917-C918	EV1050351	Elect., 1 μ F, +40%, -20%, 35V
C919	EA4760509	Elect., 47 μ F, 50V
C924-C925	EE1060251	Elect., 10 μ F, 25V
C928-C929	DF6545101	Mylar, 450pF, $\pm 5\%$
C930-C931	DD1650001	Ceramic, 50pF, $\pm 10\%$, 50V
SEMICONDUCTORS		
H901-H902	HT313441E	Transistor, 2SC1344E
H903-H904	HT304580S	Transistor, 2SC458 LG, AC
MISCELLANEOUS		
J901-J909	YP1000099	Plug
J912-J917	YP1000099	Plug
P500	YD2821005 (ZZ2821005)	P.C. Board P.C. Board Assembly
RESISTORS		
R501-R502	RT1010214	Carbon, 1K Ω , $\pm 10\%$, 1/4W
R503-R504	RN1082414	Carbon, 820K Ω , $\pm 10\%$, 1/4W
R505-R506	RN1027414	Carbon, 270K Ω , $\pm 10\%$, 1/4W
R507-R508	RT0556214	Carbon, 5.6K Ω , $\pm 5\%$, 1/4W
R509-R510	RN1022414	Carbon, 220K Ω , $\pm 10\%$, 1/4W
R511-R512	RT0533114	Carbon, 330 Ω , $\pm 5\%$, 1/4W
R513-R514	RN1015414	Carbon, 150K Ω , $\pm 10\%$, 1/4W
R515-R518	RT1015314	Carbon, 15K Ω , $\pm 10\%$, 1/4W
R519-R520	RT1082114	Carbon, 820 Ω , $\pm 10\%$, 1/4W
R521-R522	RT1022414	Carbon, 220K Ω , $\pm 10\%$, 1/4W
R523	RT1033214	Carbon, 3.3K Ω , $\pm 10\%$, 1/4W

REF. DESIG.	MARANTZ PART NO.	DESCRIPTION	REF. DESIG.q	MARANTZ PART NO.	DESCRIPTION
C501-C502	DF1722402	CAPACITORS Mylar, 0.22 μ F, \pm 20%	R603-R604	RT0510414	Carbon, 100K Ω , \pm 5%, 1/4W
C503-C504	EA4750359	Elect., 4.7 μ F, 35V	R605-R606	RT1010214	Carbon, 1K Ω , \pm 10%, 1/4W
C505-C506	EV1050252	Elect., 1 μ F, 25V	R607-R608	RT1047214	Carbon, 4.7K Ω , \pm 10%, 1/4W
C507-C508	DD1630001	Ceramic, 30pF, \pm 10%			CAPACITORS
C509-C510	EA1070109	Elect., 100 μ F, 10V	C601-C602	DF1733301	Mylar, 0.033 μ F, \pm 20%, 50V
C511-C512	EA1060359	Elect., 10 μ F, 35V	C603-C604	DD1510101	Ceramic, 100pF, \pm 5%
C513-C514	EV3350252	Elect., 3.3 μ F, 25V			MISCELLANEOUS
C515	EA1070359	Elect., 100 μ F, 35V	S601	SP0203002	Push Switch for Loudness, Tape Mo Plug
H501-H502	HT304580Z	SEMICONDUCTORS Transistor, 2SC458LG (D)	J601-J608	YP1000099	
H503-H506	HT304580Y	Transistor, 2SC458LG (C)	P700	YD2821007 (ZZ2821007)	P.C. Board P.C. Board Assembly
J501-J517	YP1000099	MISCELLANEOUS Plug			RESISTORS
P650	YD2829001 (ZZ2829001)	P.C. Board P.C. Board Assembly	R701-R702	RT1010214	Carbon, 1K Ω , \pm 10%, 1/4W
R651-R652	RT1068214	RESISTORS Carbon, 6.8K Ω , \pm 10%, 1/4W	R703-R704	RN1015514	Carbon, 1.5M Ω , \pm 10%, 1/4W
R653-R654	RT1012214	Carbon, 1.2K Ω , \pm 10%, 1/4W	R705-R706	RN1056314	Carbon, 56K Ω , \pm 10%, 1/4W
R655-R656	RM0503043	Variable, 50K Ω , A	R707-R708	RC1082212	Solid, 8.2K Ω , \pm 10%, 1/2W
R657-R658	RT1027214	Carbon, 2.7K Ω , \pm 10%, 1/4W	R709-R710	RT1056214	Carbon, 5.6K Ω , \pm 10%, 1/4W
R659-R660	RT1022414	Carbon, 220K Ω , \pm 10%, 1/4W	R711-R712	GT0520112	Carbon, 200 Ω , \pm 5%, 1/2W
R661-R662	RT1033214	Carbon, 3.3K Ω , \pm 10%, 1/4W	R713-R714	RC1033112	Solid, 330 Ω , \pm 10%, 1/2W
C651-C652	DF1747201	CAPACITORS Mylar, 0.0047 μ F, \pm 20%, 50V	R715-R716	GT0522212	Carbon, 2.2K Ω , \pm 5%, 1/2W
C653-C654	DF1733301	Mylar, 0.033 μ F, \pm 20%, 50V	R717-R718	RN1010414	Carbon, 100K Ω , \pm 10%, 1/4W
C655-C656	DF1740301	Mylar, 0.04 μ F, \pm 20%, 50V	R719-R720	RT1012314	Carbon, 12K Ω , \pm 10%, 1/4W
C657-C658	DF1722402	Mylar, 0.22 μ F, \pm 20%, 50V	R721-R722	RC1039212	Solid, 3.9K Ω , \pm 10%, 1/2W
J651-J656	YP1000099	MISCELLANEOUS Plug	R723-R724	RA0104012	Trimmer, 100K Ω , B
P300	YD2828002 (ZZ2828002)	P.C. Board P.C. Board Assembly	R725-R726	RC1010112	Solid, 100 Ω , \pm 10%, 1/2W
R307-R308	RT0547214	RESISTORS Carbon, 4.7K Ω , \pm 10%, 1/4W	R727-R728	RC1082212	Solid, 8.2K Ω , \pm 10%, 1/2W
R309-R310	RT1022514	Carbon, 2.2M Ω , \pm 20%, 1/4W	R729-R730	RA0501005	Trimmer, 470 Ω , B
R311-R312	RT1010101	Carbon, 100 Ω , \pm 10%, 1W	R731-R734	RC1039112	Solid, 390 Ω , \pm 10%, 1/2W
C303-C304	DF1668201	CAPACITORS Mylar, 0.0068 μ F, \pm 10%, 50V	R735-R736	RC1010012	Solid, 10 Ω , \pm 10%, 1/2W
S301	SP0403005	MISCELLANEOUS Push Switch	R737-R740	RC1022112	Solid, 220 Ω , \pm 10%, 1/2W
J303-J308	YP1000099	Plug	R741-R742	RC1068112	Solid, 680 Ω , \pm 10%, 1/2W
P600	YD2828003 (ZZ2828003)	P.C. Board P.C. Board Assembly	R743-R744	RC1022012	Solid, 22 Ω , \pm 10%, 1/2W
R601-R602	RT0510314	RESISTORS Carbon, 10K Ω , \pm 5%, 1/4W	R745-R746	RC1068112	Solid, 680 Ω , \pm 10%, 1/2W
			R747-R750	GW1050202	Wire Wound, 0.5 Ω , 2W
			R753-R754	RC1010012	Solid, 10 Ω , \pm 10%, 1/2W
			R755-R758	RC1033312	Solid, 33K Ω , \pm 10%, 1/2W
			C701-C702	EV4740251	CAPACITORS Elect., 0.47 μ F, 25V
			C703-C704	EA3370509	Elect., 330 μ F, 50V
			C705-C706	DD1650001	Ceramic, 50pF, \pm 10%, 50V
			C707-C710	EA4760509	Elect., 47 μ F, 50V
			C711-C712	EA1060359	Elect., 10 μ F, 35V
			C713-C714	DD1630001	Ceramic, 30pF, \pm 10%
			C715-C716	EA1070109	Elect., 100 μ F, 10V
			C717-C718	EA2260359	Elect., 22 μ F, 35V
			C719-C722	DD1650001	Ceramic, 50pF, \pm 10%
			C723-C724	DF3610152	Mylar, 100pF, \pm 10%
			C725-C726	DF1710452	Mylar, 0.1 μ F, \pm 20%, 200V
			C727-C728	DD1610101	Ceramic, 100pF, \pm 10%

REF. DESIG.	MARANTZ PART NO.	DESCRIPTION	REF. DESIG.	MARANTZ PART NO.	DESCRIPTION
H701-H702	HT309452A	SEMICONDUCTORS Transistor, 2SC945 Q, R	H001-H004	HK031519A	SEMICONDUCTORS Transistor, 2SD315DE, 2SD315DE
H703-H704	HT308532A	Transistor, 2SC853 M. L	H005	HV0000212	Varistor, SV-3A
H705-H706	HT303711B	Transistor, 2SC371 O	H006	HV0000212	Varistor, SV-3A
H707-H708	HT105621B	Transistor, 2SA562 O	H007	HD2000510	Diode, 5B2
H709-H712	HK060619A	Transistor 2SC959 2SA606 N.M.L	S001	SR0605009	MISCELLANEOUS Rotary Switch for Function
H713-H714	HV0000705	Varistor, S3016R	S002	SP0201010	Push Switch for Power
H715-H718	HD1000105	Diode, 1N60	M001	IN1008001	Lamp for Power
J701-J726	YP1000099	MISCELLANEOUS Plug	F001	FS1015002	Fuse, UL-1.5A
P800	YD2828004 (ZZ2828004)	P.C. Boad P.C. Board Assembly	L001	TS1850301	Power Transf.
R801	RC1047012	RESISTORS Solid, 47Ω, ±10%, 1/2W	L002-L003	LL2291512	Choke Coil
R802	RC1082212	Solid, 8.2KΩ, ±10%, 1/2W	W001	YC0240010	AC Cord
R803	RC1033312	Solid, 33KΩ, ±10%, 1/2W	W002-W003	YB0007001	Connective Cord
R804	RC1047112	Solid, 470Ω, ±10%, 1/2W	W004	YB0027001	Connective Cord
R805	RC1012212	Solid, 1.2KΩ, ±10%, 1/2W	W005	YW2829001	Wire Material
C801-C802	DK1810351	CAPACITORS Ceramic, 0.01μF, +100%, -0%, 500V	W006	YX2829001	Wire Material
C803	EB4770631	Elect., 470μF, 63V	J001	YJ0100055	Mic In Jack
C804-C805	EA1070509	Elect., 100μF, 50V	J004	YL0301021	Ground Terminal
C806	EA2270631	Elect., 220μF, 63V	J006	YT0204003	4P (Pre Out Main in) Terminal
H801	HT312132A	SEMICONDUCTORS Transistor, 2SC1213A B or C	J009	YJ0100065	Headphone Jack
H802-H803	HD2000413	Diode, SIB-01-02	J010	YL0106004	Terminal for AC Voltage Select
J801-J803	YP1000099	MISCELLANEOUS Plug	J011	YJ0800012	Fuse Holder Jack
J805-J808	YP1000099	Plug	J014	YL0105004	5P Terminal
R001-R002	RT1030414	RESISTORS Carbon, 300KΩ, ±10%, 1/4W	J015	YJ0200007	Lamp Socket
R003-R004	RT1010414	Carbon, 100KΩ, ±10%, 1/4W	J016-J017	YL0103011	3P Terminal
R007	RM0254019	Variable, 250KΩ HB Balance	J018-J019	YP1000097	Pre Out/Main in Plug
R008	RM0254021	Variable, 250KΩ A Volume	J023	YL0107005	7P Terminal
R009-R010	RT1022414	Carbon, 220KΩ, ±10%, 1/4W			
R011-R012	RC1047012	Solid, 47Ω, ±10%, 1/2W			
R013	GT0522501	Carbon, 2.2MΩ, ±5%, 1W			
R014-R015	RC1002212	Solid, 2.2Ω, ±10%, 1/2W			
R016	RT1047214	Carbon, 4.7KΩ, ±10%, 1/2W			
C001-C002	DK1710301	CAPACITORS Ceramic, 0.01μF, 50V			
C003-C004	EC2280352	Elect., 2200μF, 35V			
C005	EC4780551	Elect., 4700μF, 55V			
C006-C007	DO0720350	Oil Paper, 0.02μF, ±20%, 600VDC			
C008	DO0733380	Oil Paper, 0.033μF, ±20%, 800VAC			
C009	DD1620101	Ceramic, 200pF			
C010	DD1650001	Ceramic, 50pF			
C011-C012	DO0710281	Oil Paper, 0.001μF, ±20%, 800V			

SPECIFICATIONS

Gain—Phone (low level) to pre-amp output	54 dB
Phono to recording output	37 dB
High level to pre-amp output	17 dB
Input Impedance—Low level input	Phone 47K Microphone 47K
High level input	100K
Input Sensitivity—Phono (low)	2.1mV to equal 1 volt output at pre-amp out
Frequency Response	±1 dB, 20 Hz to 20 KHz at rated power output
Intermodulation Distortion	Less than 0.5% at rated power output from 40 Hz to 20 KHz with both channels driven (S.M.P.T.E.)
Total Harmonic Distortion	Less than 0.5% at rated power output 40 Hz to 20 KHz with both channels driven
Damping Factor	Greater than 45 into 8 ohms load
Total Noise—From magnetic phono input to power amp output	Less than 1.5 μ V equivalent input at rated output into 8 ohms
Volume Tracking	Within 3 dB
Rated continuous (RMS) power output per channel, both channels operating simultaneously	15 Watts at 4 and 8 ohms 10 Watts at 16 ohms
Comparable Total Music Power (IHF)	45 Watts at 8 ohms
Power Requirements	100/120/200/220/240V AC
At rated output, both channels operating	110 Watts
Idling Power (Volume Control at zero)	29 Watts
Dimensions—Panel Width	14-11/64 inches
Panel Height	4-23/32 inches
Depth	11-1/32 inches
Weight—Unit alone	16.5 lbs
Packed for shipment	23.3 lbs

* These specifications and exterior designs may be changed for improvement without advance notice.

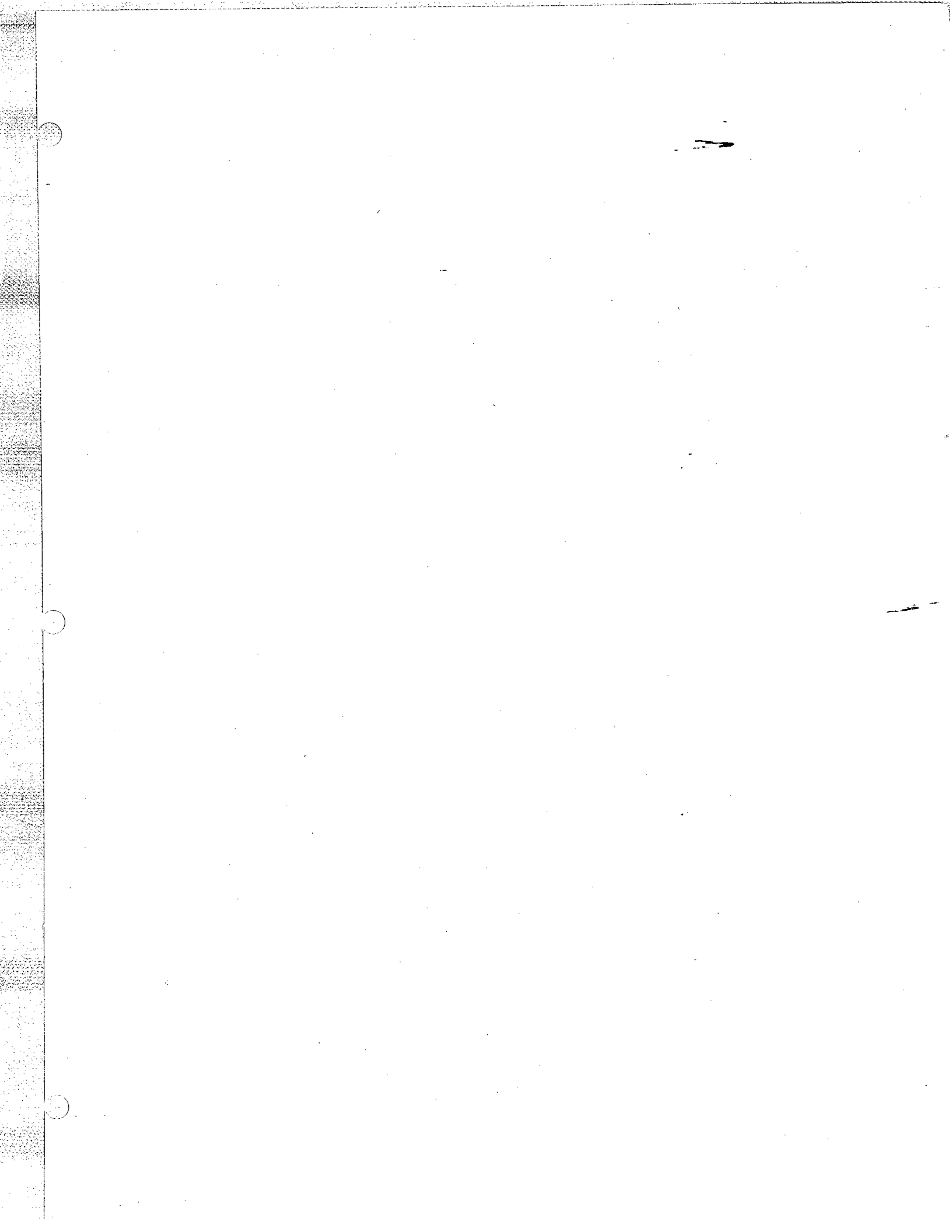



marantz

MARANTZ CO., INC. • P.O. BOX 99 • SUN VALLEY, CALIFORNIA • 91352

A WHOLLY-OWNED SUBSIDIARY OF SUPERSCOPE INC., SUN VALLEY, CALIFORNIA 91352