

264

SERVICE
MANUAL **1300DC**



marantz

model **1300DC**

Stereo Console Amplifier

MARANTZ DESIGN AND SERVICE

Using superior design and selected high grade components, MARANTZ Company has created the ultimate in stereo sound. Only original MARANTZ parts can insure that your MARANTZ product will continue to perform to the specifications for which it is famous.

Parts for your MARANTZ stereo are generally available within 72 hours throughout the nation via a toll-free line to our National Parts Depot in California. The sales professionals who take your call immediately refer to their own desk top computer terminal and can quickly determine the availability and price information you require. If for some reason, your order should exceed our available stock, we usually can instantly provide an alternate replacement part or current delivery information. When the order is placed and confirmed, the computer simultaneously generates "hard copy" orders at the distribution center. As hard copies come directly from the computer to the national parts depot, your requested stock is assembled and prepared for shipment and placed on the first available carrier for delivery to you.

ORDERING PARTS

Phone orders will eliminate mail delays, and we encourage the use of this method. If you order by mail, use MARANTZ parts order forms which are available from our National Parts Depot located at the following address:

SUPERSCOPE NATIONAL PARTS DEPARTMENT
20525 Nordhoff Street
Chatsworth, California 91311
Phone: 1-800-423-5108
1-213-998-9333

The following information must be supplied to eliminate delays in processing your order:

1. Complete address.
2. Complete part numbers.
3. Complete description of parts.
4. Model number for which part is required (indicate MARANTZ).
5. Account number (for account customers only).

Direct consumers will be provided with the current retail price quotation on available parts in order to advise them of the cost of the parts and shipping.

OVERSEAS PARTS ORDERING

Parts may also be ordered from the following overseas addresses:

CANADA

Superscope Canada, Ltd.
3710 Nashua Drive
Mississauga
Ontario, Canada L4V1M5

AUSTRALIA

Superscope (Australasia) Pty., Ltd.
32 Cross Street (P.O. Box 604)
Brookvale 2100 N.S.W.
Australia

JAPAN

Marantz Japan, Inc.
3622 Kamitsuruma
Sagamihara Shi
Kanagawa, Japan

EUROPE

Superscope Europe, S.A.
Avenue Leopold III, 2
7120 Perennes-Lez-Binche
Belgium

Marantz France
Rue Louis Armand 9
92600 Asnieres
Hauts-de-Seine
France

Marantz Audio U.K. Ltd.
London Road, 203
Staines
Middlesex
England

Superscope GmbH
Max-Planck-Strasse 22
D-6072 Dreieich 1
West Germany

All of the above locations are fully equipped to take care of your total service needs. Because various countries have differing configuration requirements, it is necessary that you contact the service facility in your particular country. In the event that there is no service location listed for your country, please contact the nearest facility for the necessary assistance.

marantz
We sound better.

TABLE OF CONTENTS

SECTION	PAGE
1. POWER AMPLIFIER ADJUSTMENT	1
2. POWER SUPPLY ADJUSTMENT	1
3. TEST EQUIPMENT REQUIRED FOR SERVICING	1
4. VOLTAGE CONVERSION (For European Model)	3
5. BLOCK DIAGRAM	4
6. DIAGRAM AND COMPONENT LOCATIONS	5
6.1 Main Amp Assembly (P700/P703,4/P705,6) Schematic Diagram and Component Locations	5
6.2 Power Supply Assembly (P800) Schematic Diagram and Component Locations	5
6.3 Peak and Relay Assembly (PN01) Schematic Diagram and Component Locations	6
6.4 Pre Amp Assembly (PE00) Schematic Diagram and Component Locations	7
6.5 Tone VR Assembly (PF00) Schematic Diagram and Component Locations	8
6.6 Tone VR Selector Assembly (PF01) Schematic Diagram and Component Locations	8
6.7 Cartdge Load Assembly (PL00) Schematic Diagram and Component Locations	8
6.8 Spk SW Assembly (PW00) Schematic Diagram and Component Locations	8
6.9 Volume Assembly (PG00) Schematic Diagram and Component Locations	9
6.10 Contour Assembly (P600) Schematic Diagram and Component Locations	9
6.11 Mc Amp Assembly (PM00) Schematic Diagram and Component Locations	9
6.12 Tape EQ Buffer Amp Assembly (PK00) Schematic Diagram and Component Locations	10
6.13 Selector Assembly (PJ00) Schematic Diagram and Component Locations	10
6.14 Phono Amp Assembly (P400) Schematic Diagram and Component Locations	11
6.15 Rcapin Tack Assembly (PV00) Schematic Diagram and Component Locations	11
7. EXPLODED VIEWS AND PARTS LIST	12
8. ELECTRICAL PARTS LIST	19
9. TECHNICAL SPECIFICATIONS	29
10. SCHEMATIC DIAGRAM	32

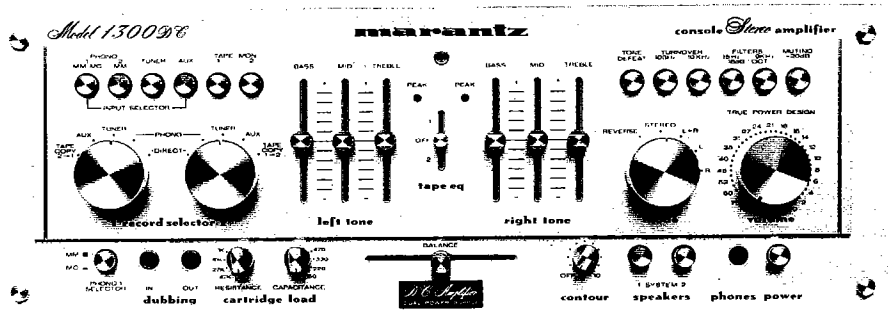

1. POWER AMPLIFIER ADJUSTMENT

1.1 Adjustment of idling current

Connect VTVM between left channel R760 and R761. Adjust R733 until the meter reads 20mV. Similarly, connect VTVM between right channel R760 and R761 and adjust R733 until the meter reads 10mV.

1.2 DC-OFFSET adjustment

Connect VTVM to JW02 and JW08 (or ground) and adjust left channel R720 until the meter indication

reaches 0mV ($\pm 5mV$). Similarly, connect VTVM to JW04 and JW08 (or ground) and adjust right channel R720 until the meter indication reaches 0mV ($\pm 5mV$).

2. POWER SUPPLY ADJUSTMENT

Connect a voltmeter between J810 and J820. Adjust R810 until meter indicates 31 VDC. Similarly connect a voltmeter between J812. Check to make sure that the meter indicates - 31 V.

3. TEST EQUIPMENT REQUIRED FOR SERVICING

Table 1 lists the test equipment required for servicing the Model 1180DC Stereo Console Amplifier. The wattmeter, AC voltmeter, and variable autotransformer may be assembled as a test fixture as shown schematically in Figure 1. The load resistors and AC ammeter may be assembled into a second test fixture as shown in Figure 2.

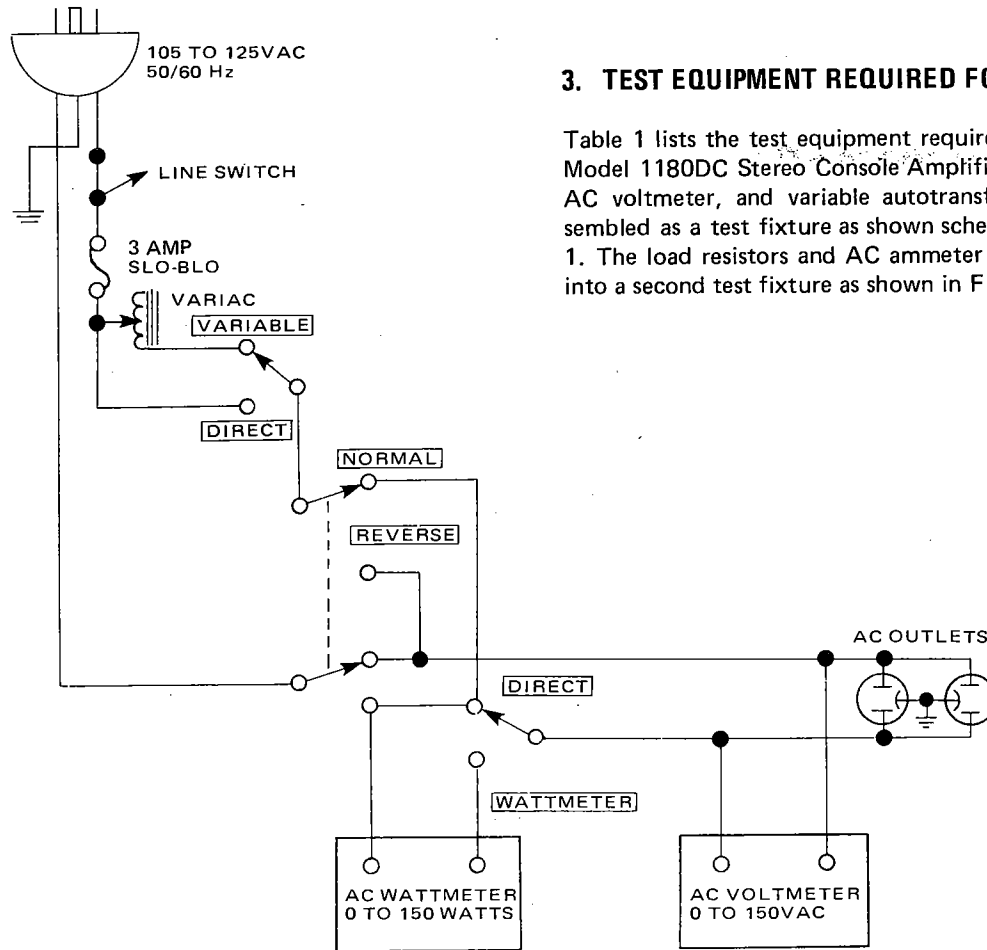

Figure 1. AC Power Control Box Simplified Schematic

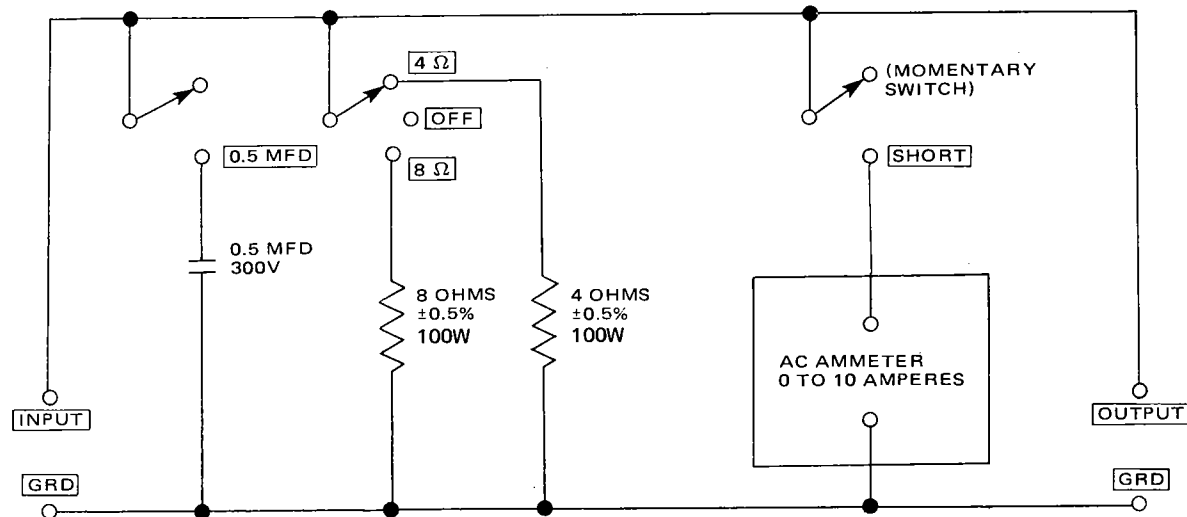

Figure 2. Amplifier Output Load Box Simplified Schematic

Table 1. Test Equipment Required for Servicing

Item	Manufacturer and Model No. (or equivalent)	Use
Distortion Analyzer and Audio Oscillator	Spund Technology, Model 1700B (NOTE : Less then 0.002 percent residual distortion is required.)	Measures distortion, voltage of amplifier output and sinewave source
Oscilloscope	Tektronix, Model 503 Data, Model 555	Waveform analysis and troubleshooting.
VTVM	RCA Senior Volt-Ohmyst, Model WV-98C	Voltage and resistance measurements.
AC Wattmeter	Simpson, Model 390	Monitors primary power consumption of amplifier.
AC Ammeter (0 to 10 amps)	Commercial Grade	Monitors amplifier output under short circuit condition.
Line Voltmeter (0 to 150V AC)	Commercial Grade	Monitors potential of primary power to amplifier.
Variable Autotransformer (0 to 140V AC, 10 amps)	Powerstat, Model 116B	Adjusts level of primary power to amplifier.
Shorting Plug	Use phono plug with 600 ohms across center pin and shell.	Shorts amplifier input to eliminate noise pickup.
Power Supply Bleeder Resistor (10 ohms at 1 W)	Commercial Grade	Discharges power supply filter capacitors prior to disassembly or resistance measurements.
Output Load Resistor (8 Ω ±0.5%, 250W)	Commercial Grade	Provides 8-ohm load for amplifier output termination.
Output Load Resistor (4 Ω ±0.5%, 250W)	Commercial Grade	Provides 4-ohm load for amplifier output termination.
Output Load Capacitor (0.5 mfd)	Mylar	Provides capacitive load for instability checks.
AC Power Control Box	Optional Item. Fabricate in accordance with Figure 1.	Monitors and controls primary power for amplifier.
Amplifier Output Load Box	Optional Item Fabricate in accordance with Figure 2.	Provides various amplifier loads and can monitor shorted output.

4. VOLTAGE CONVERSION

● EUROPEAN MODEL ONLY

This Model is equipped with a universal power transformer to permit operation at 110, 120, 220 and 240 V AC 50/60 Hz.

To convert the unit to the required voltage, set the plug as illustrated so that you can adjust the voltage as required.

CAUTION

DISCONNECT POWER SUPPLY CORD FROM AC OUTLET BEFORE CONVERTING VOLTAGE.

Figure 3. Voltage Conversion Chart

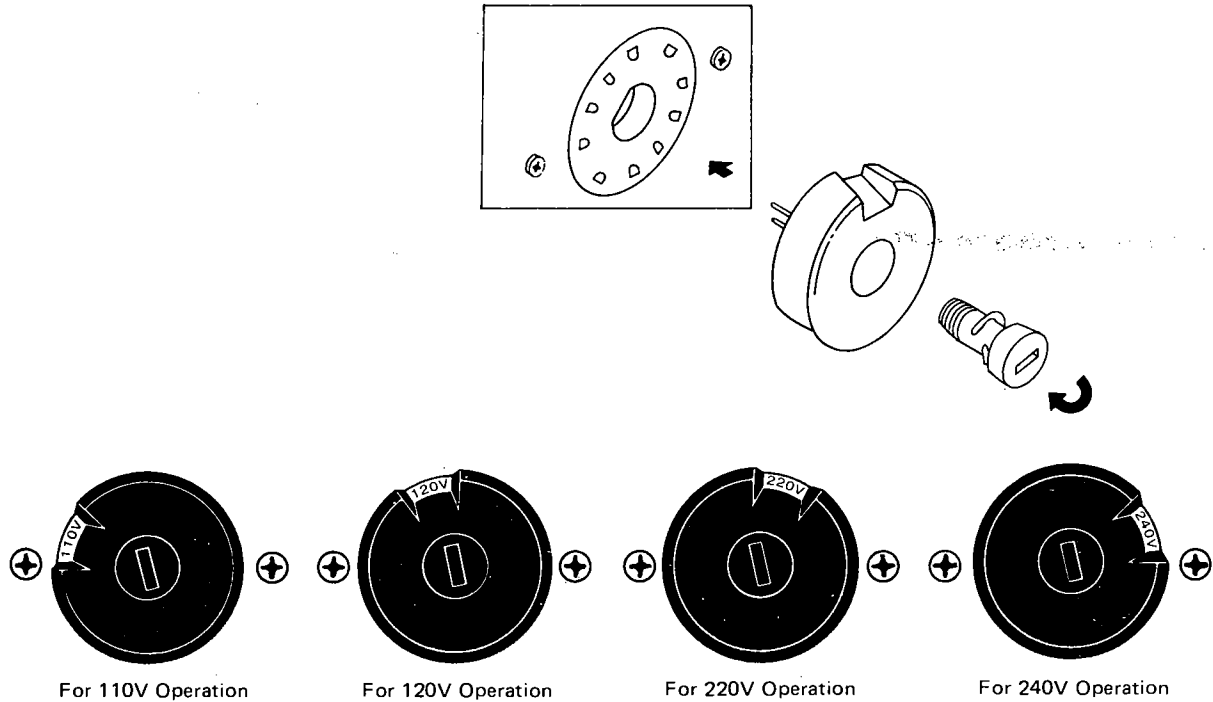

Removal Procedure of P.W. Boards

1. Remove the screw 1 (002C) and screw 2 (003C). Remove the Upper cover
2. Remove the screw 3 (011C). Remove the bottom cover.
3. Remove the screw 4 (101F). Remove the front cover (100F).
4. Remove the controls 1 (016B), 2 (017B), 3 (019B), 4 (020B), 5 (022B) and 6 (023B), and remove the screw 5 (021B), nut 1 (020F) and bolt 1 (025B). Remove the escutcheon.
5. Remove the screws 6 (003F), 7 (005F) and 8 (034F). Then the board will be drawn out toward you.

5. BLOCK DIAGRAM

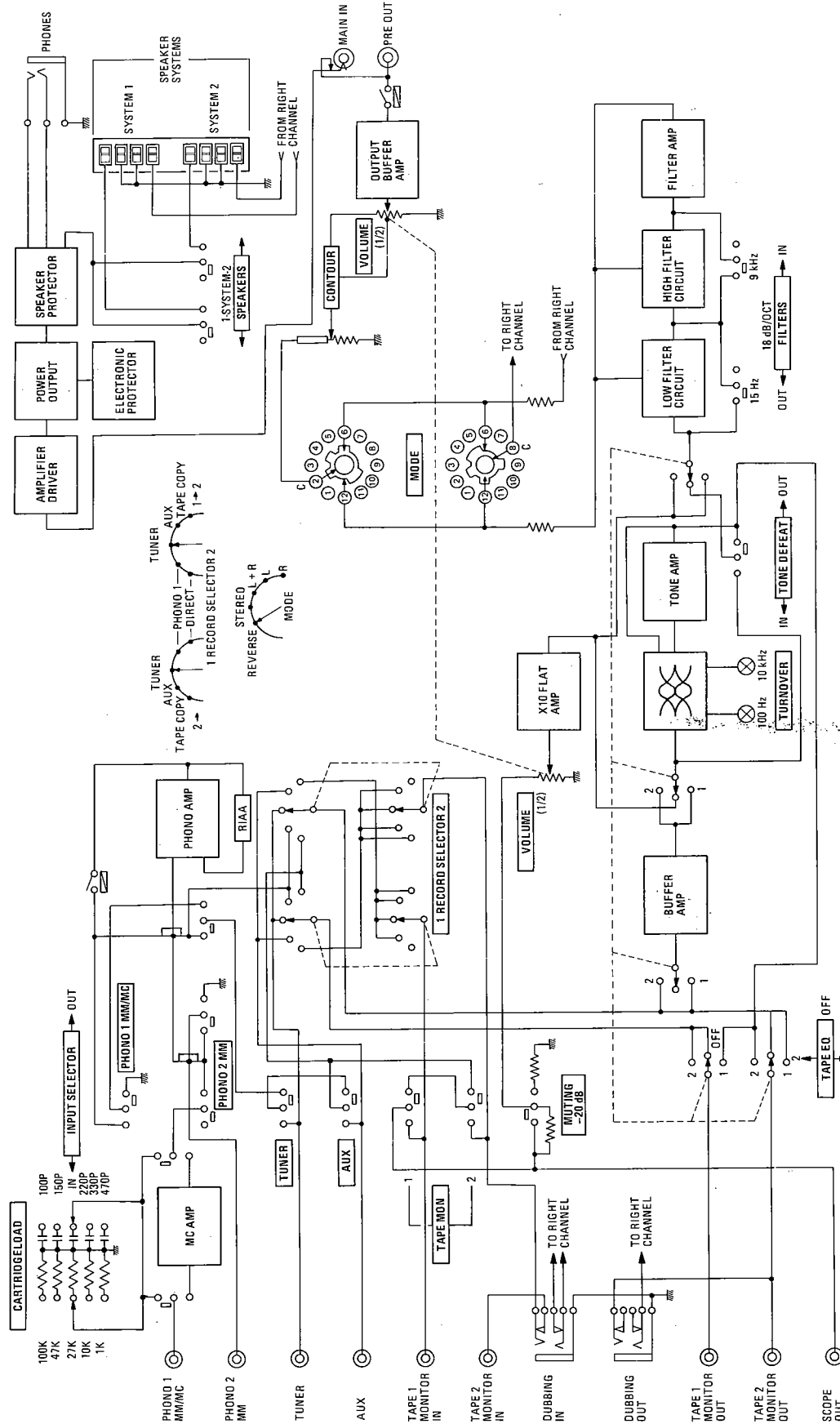

6. DIAGRAM AND COMPONENT LOCATIONS

6.1 Main Amp Assembly (P700/P703,4/P705,6) Schematic Diagram and Component Locations

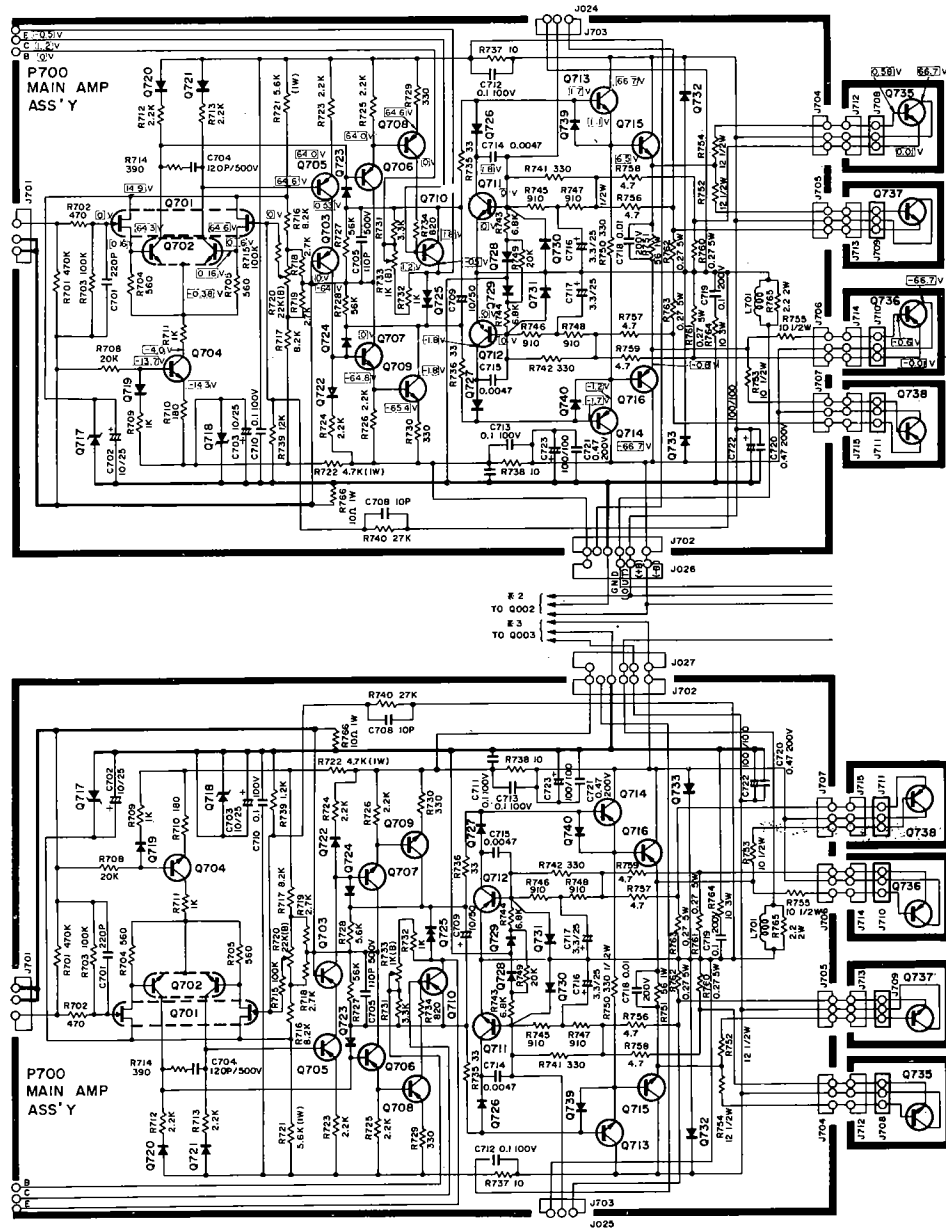

6.2 Power Supply Assembly (P800) Schematic Diagram and Component Locations

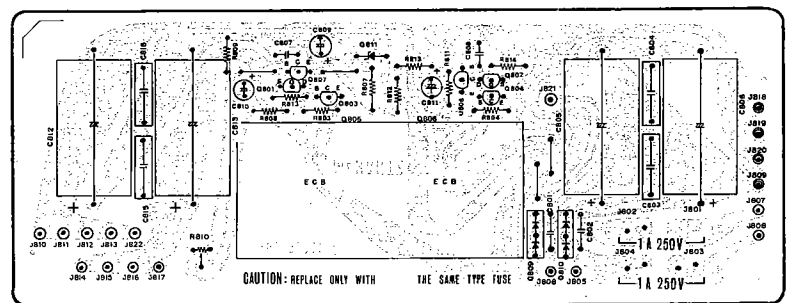
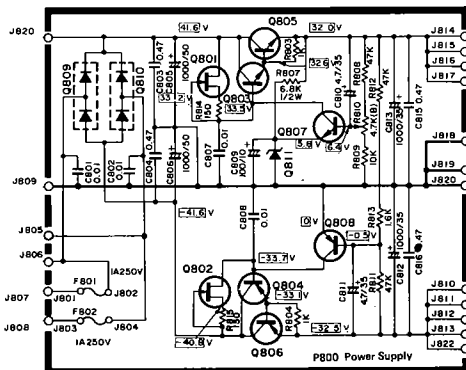

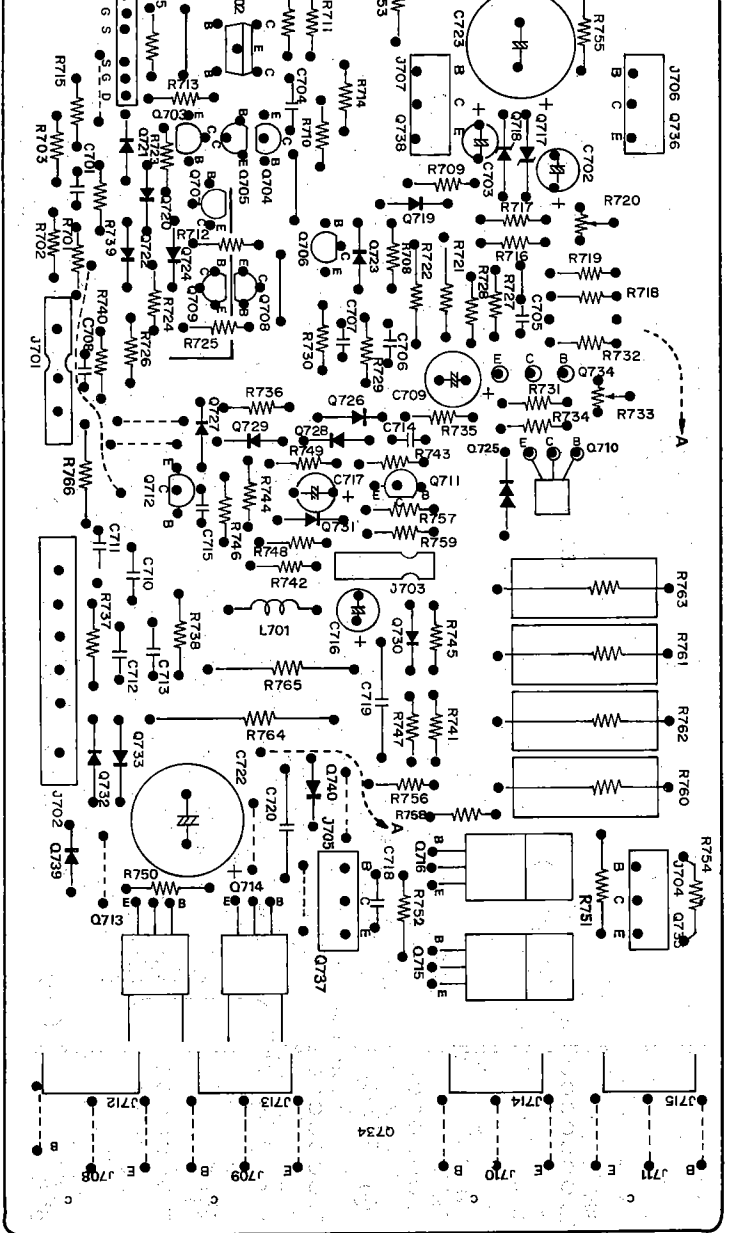

6.3 Peak and Relay Assembly (PN01) Schematic Diagram and Component Locations

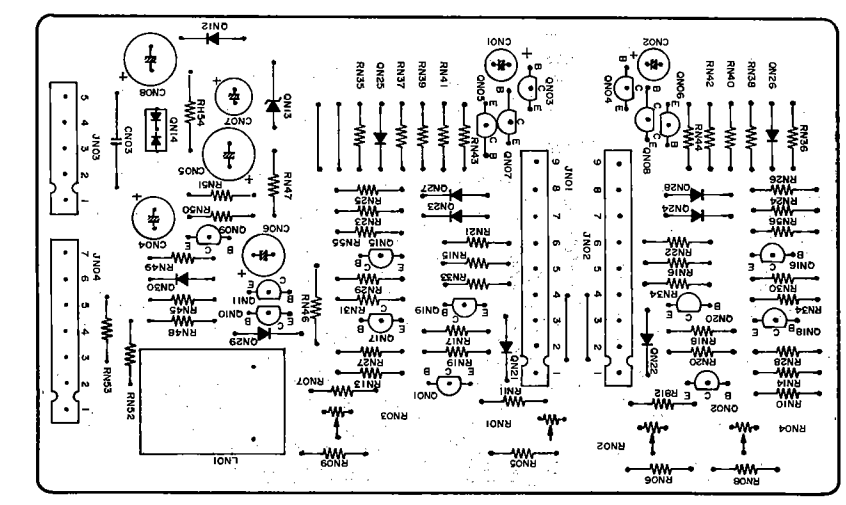
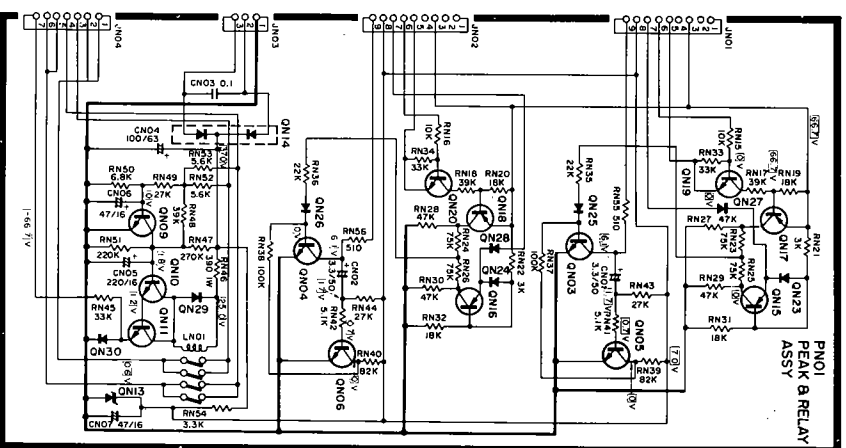

6.4 Pre Amp Assembly (PE00) Schematic Diagram and Component Locations

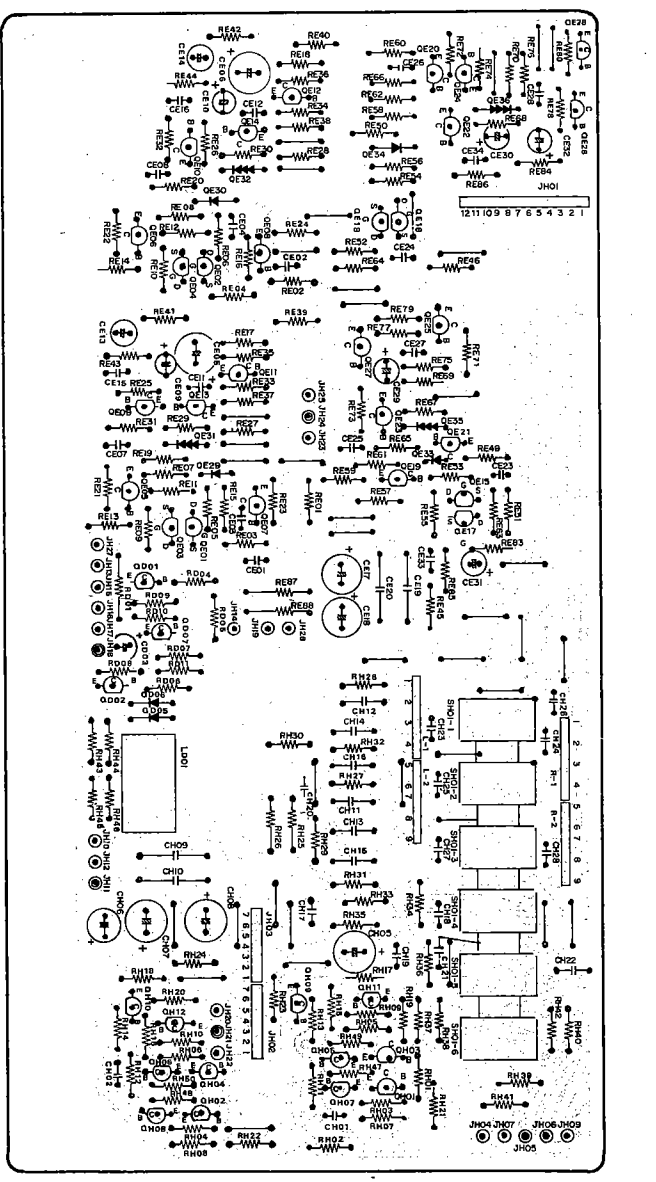
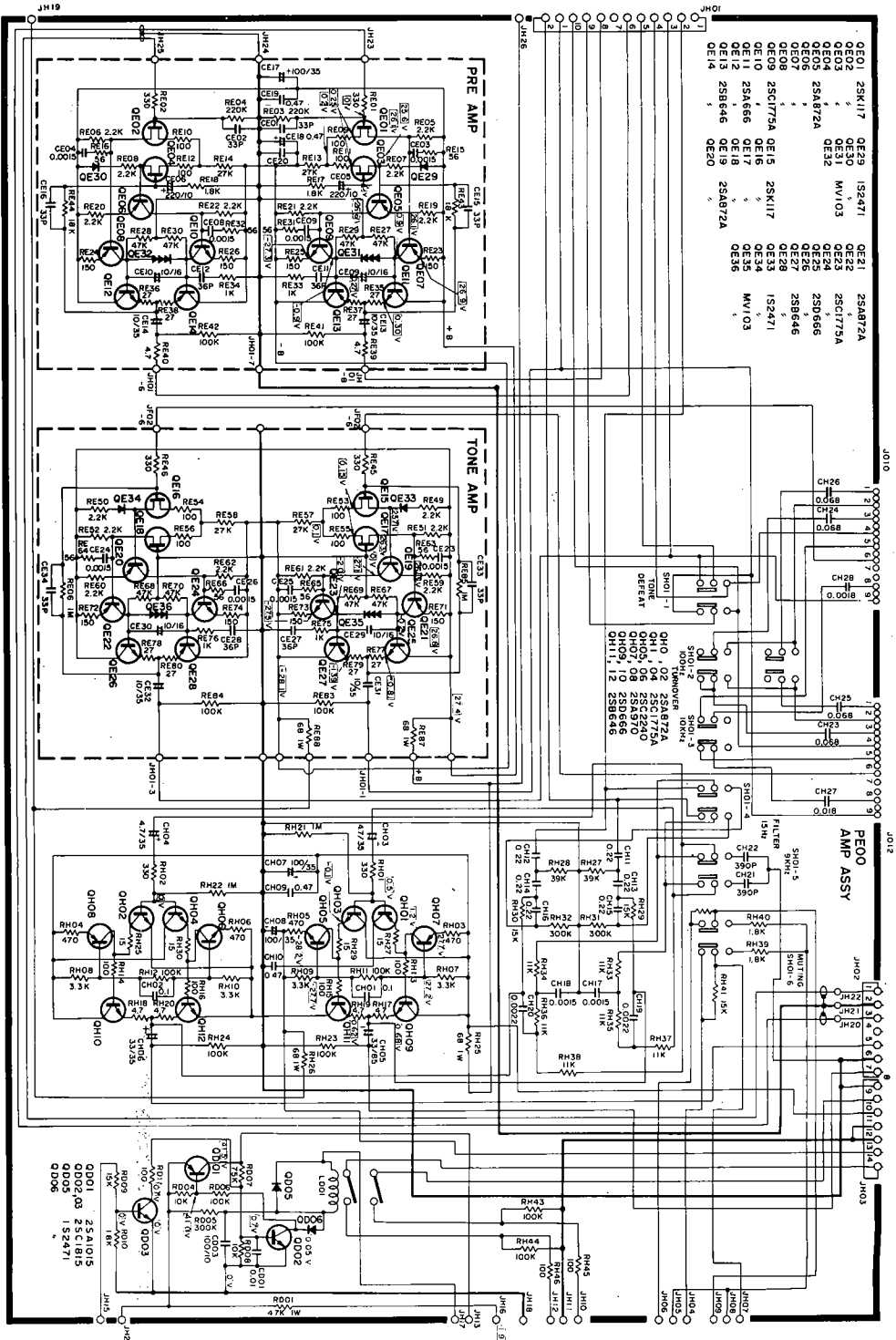

Tone VR Assembly (PF00) Schematic Diagram and Component Locations

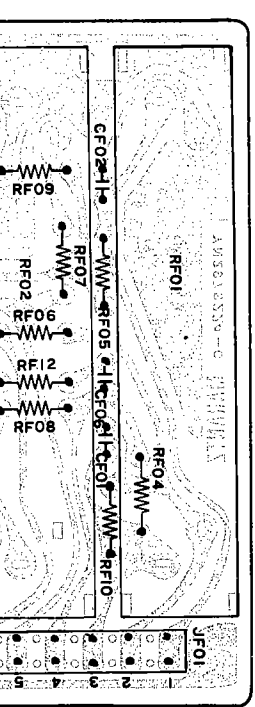
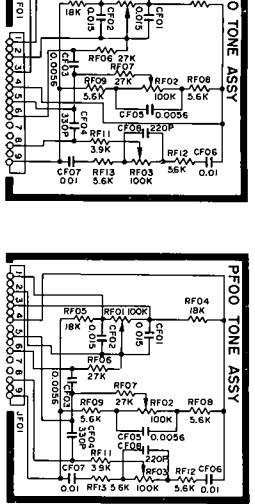

6.5 Tone VR Selector Assembly (PF01) Schematic Diagram and Component Locations

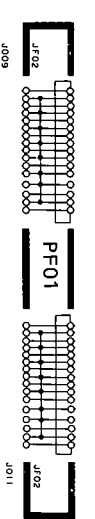

6.7 Cartridge Load Assembly (PL00) Schematic Diagram and Component Locations

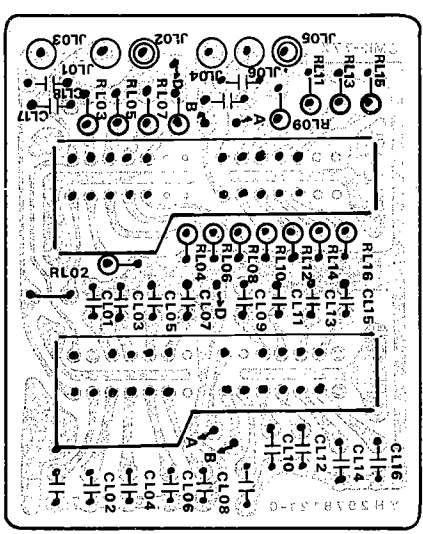
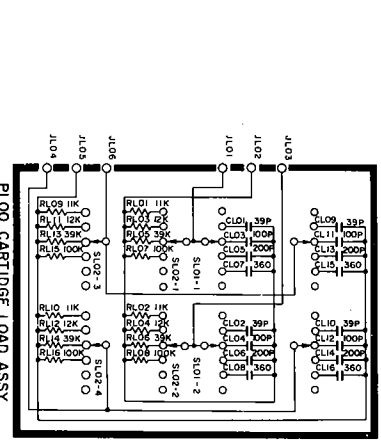

6.8 Spk SW Assembly (PW00) Schematic Diagram and Component Locations

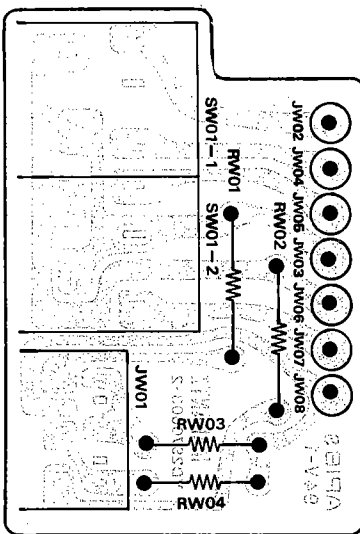
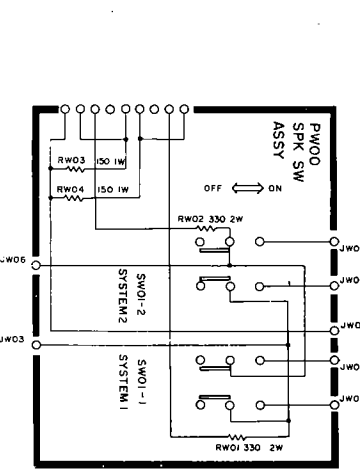

6.9 Volume Assembly (PG00) Schematic Diagram and Component Locations

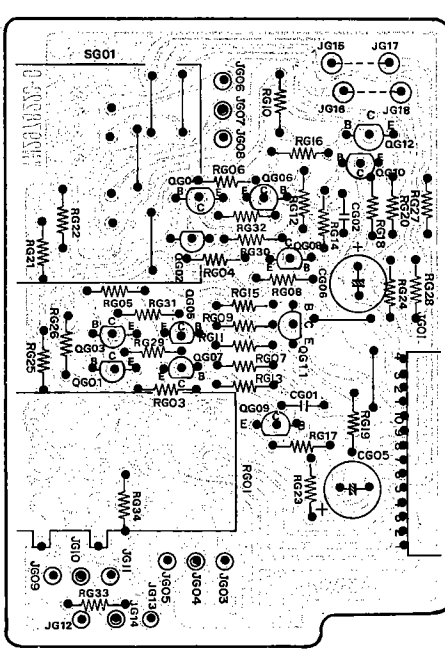
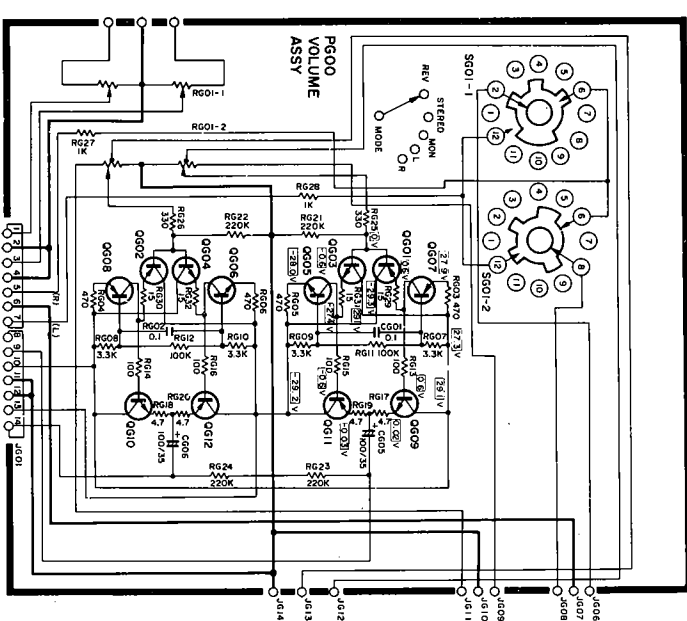

6.10 Contour Assembly (P600) Schematic Diagram and Component Locations

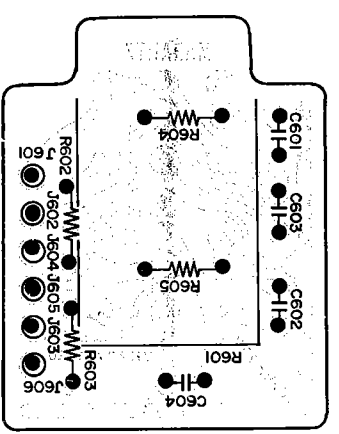
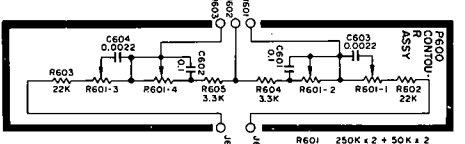

6.11 Mc Amp Assembly (PM00) Schematic Diagram and Component Locations

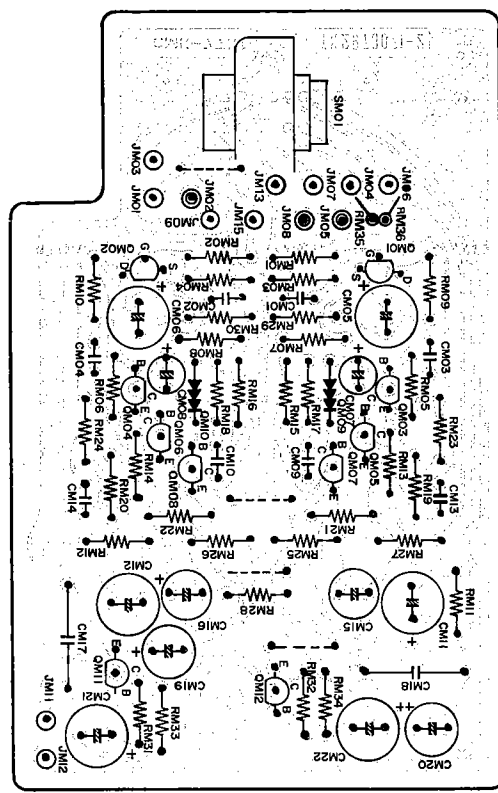
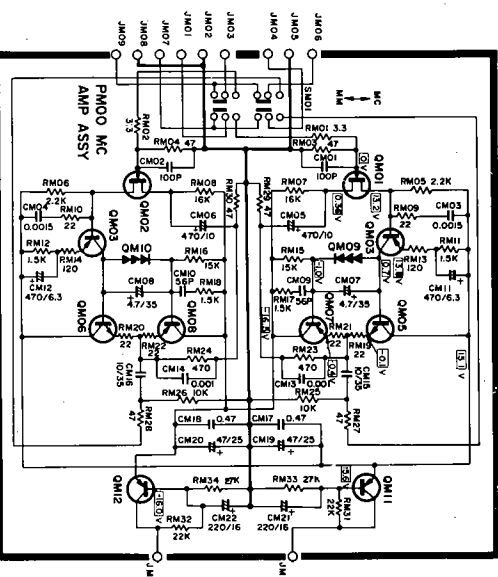

Tape EQ Buffer Amp Assembly (PK00) Schematic Diagram and Component Locations

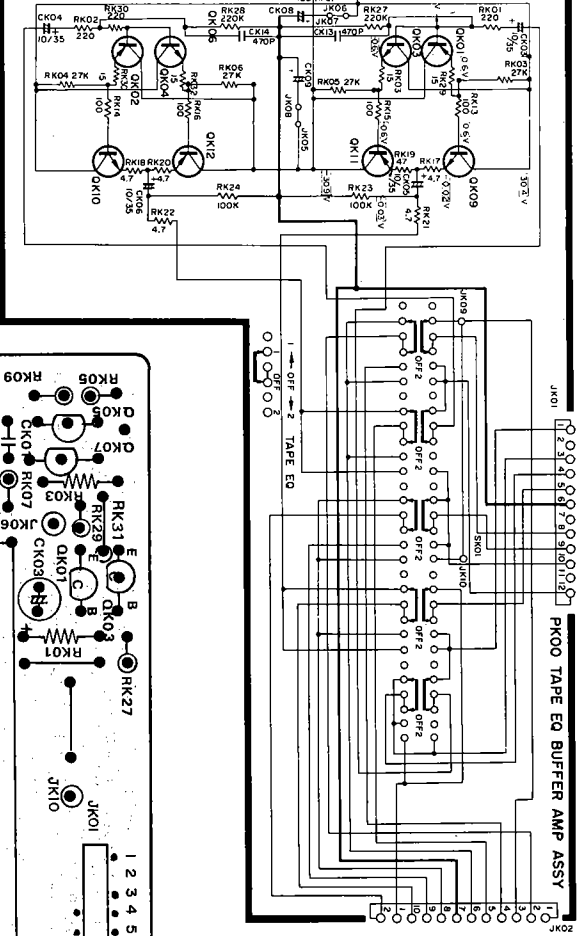

Selector Assembly (PJ00) Schematic Diagram and Component Locations

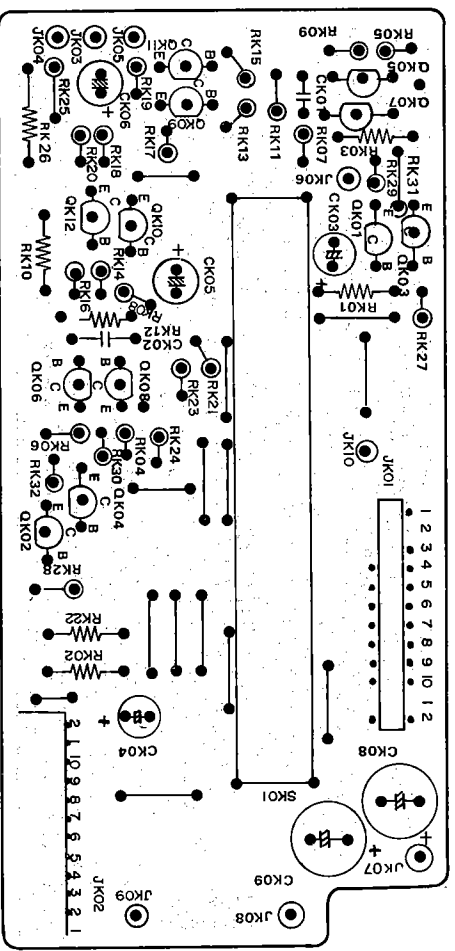
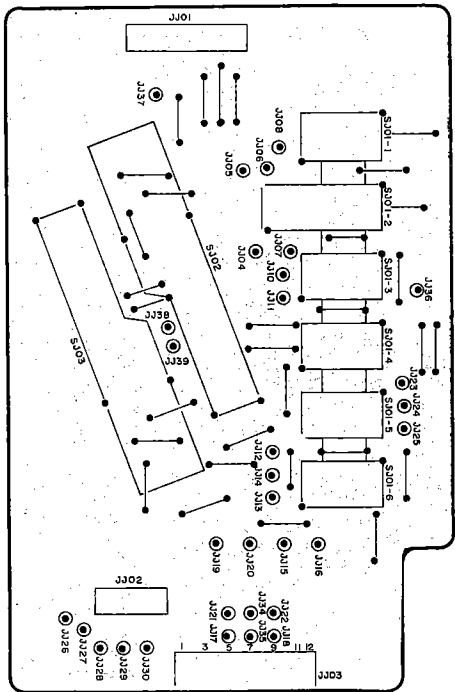
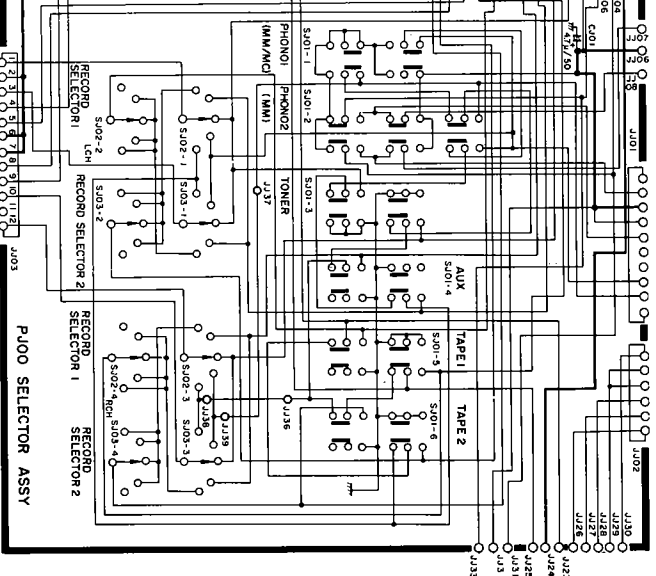

6.14 Phono Amp Assembly (P400) Schematic Diagram and Component Locations

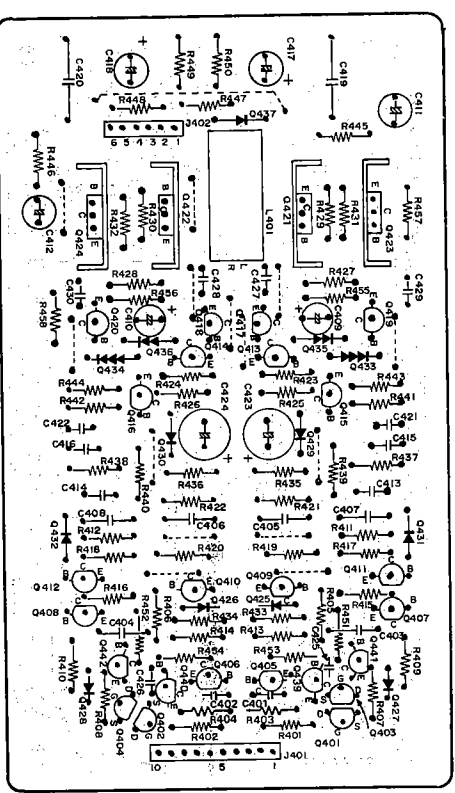
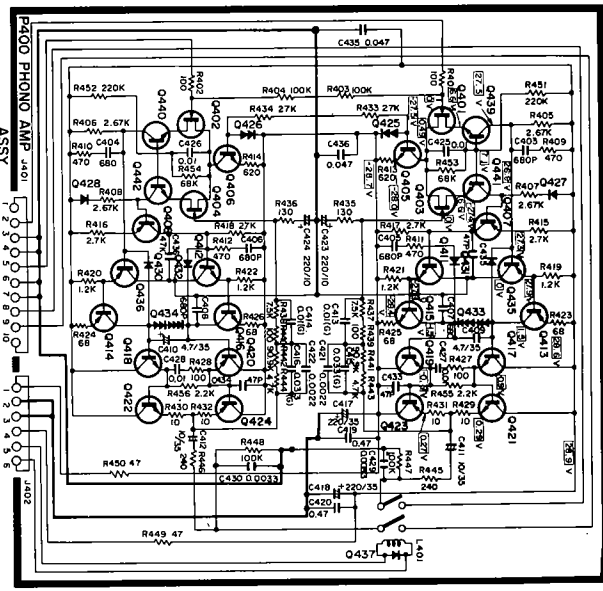

6.15 Reapin Tack Assembly (PV00) Schematic Diagram and Component Locations

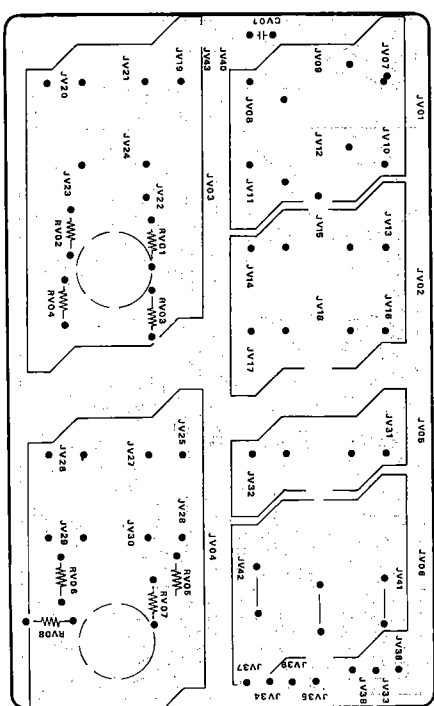
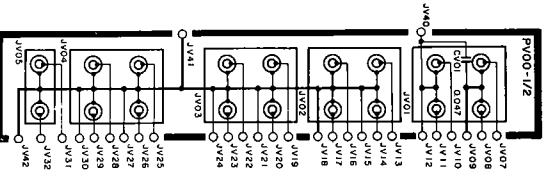

• [C03-99] Rear Panel

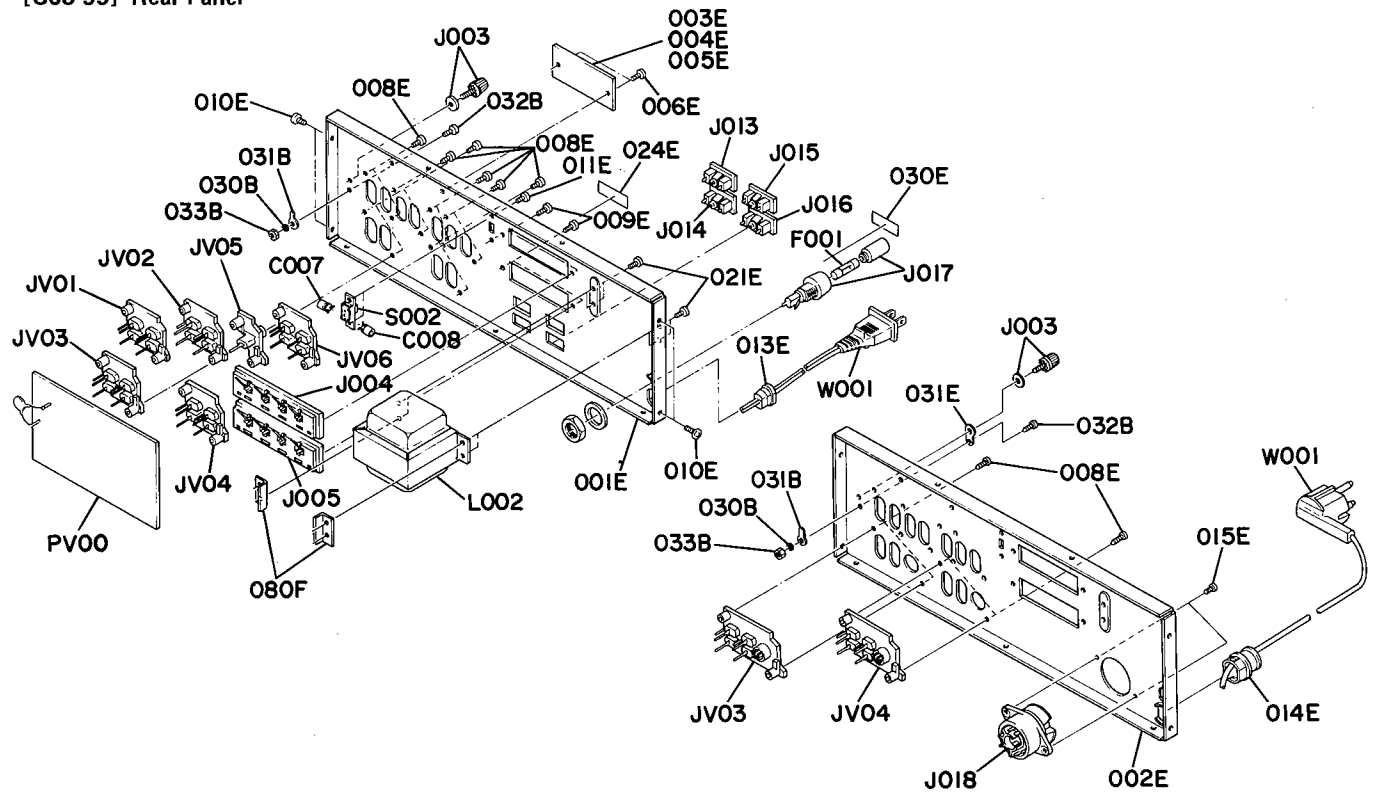

- (U): for U.S.A.
- (C): for Canada
- (N): for Europe

REF. DESIG.	Q'TY			PART NO.	DESCRIPTION
	U	C	N		
001E	1	1		2990160210	Bracket, Rear Panel
002E			1	2990160220	Bracket, Rear Panel
003E	1			2990265010	Indicator
004E		1		2990265020	Indicator
005E			1	2990265030	Indicator
006E	2	2	2	51760306B0	OS Tapped Screw 3 x 6
008E	12	12	14	51280308U0	B.H. Tapped Screw B3 x 8
009E	4	4	4	51280308U0	B.H. Tapped Screw B3 x 8
010E	4	4	4	51280308U0	B.H. Tapped Screw B3 x 8
011E	2	2	2	51100306S9	B.H.M. Screw B3 x 6
013E	1	1		1455259070	Bushing
014E			1	2286259110	Bushing
015E		2		51100308S9	B.H.M. Screw B3 x 8
021E	4	4	4	51100408S9	B.H.M. Screw B4 x 8
024E			1	2214861010	Label
030E			1	2911861250	Label
031E			1	2211123110	Contactar
030B	1	1	1	54040302N0	Spring Washer
031B	1	1	1	62030049W0	Lug
032B	1	1	1	51100308B9	B.H.M. Screw B3 x 8
033B	1	1	1	53110303E9	Hexagon Nut
080F	2	2	2	2990104070	Retainer
C007	1	1	1	EQ10601610	Elect Cap. 0.01µF 16V
C008	1	1	1	EQ10601610	Elect Cap. 0.01µF 16V
F001	1	1		FS10800040	Fuse, 4AT 250V
F001			1	FS10400800	Fuse, 8A

REF. DESIG.	Q'TY			PART NO.	DESCRIPTION
	U	C	N		
J003	1	1	1	YL03010240	Terminal, Ground
J004	1	1	1	YT03040160	Terminal, Speaker
J005	1	1	1	YT03040160	Terminal, Speaker
J013	1	1		YJ04000560	Jack, A.C. Outlet
J014	1	1		YJ04000560	Jack, A.C. Outlet
J015	1	1		YJ04000560	Jack, A.C. Outlet
J016	1	1		YJ04000560	Jack, A.C. Outlet
J017	1	1		YJ08000230	Jack, Fuse Holder
J017			1	YJ08000220	Jack, Fuse Holder
J018			1	BY03110010	Plug, Voltage Selector
L002	1	1		TS16616010	Power Transformer
L002			1	TS16616020	Power Transformer
S002	1	1	1	SS02020380	Slide Switch
W001	1	1		YC02000160	A.C. Power Cord
W001			1	YC01900030	A.C. Power Cord
PV00	1	1	1	YF29780020	P.W. Board, RCA Pin Jack
			1	ZZ29901020	P.W. Board Assembly
			1	ZZ29908020	P.W. Board Assembly
JV01	1	1	1	YT02040270	Terminal
JV02	1	1	1	YT02040150	Terminal
JV03	1	1	1	YT02040150	Terminal
JV03			1	BY01050060	Jack
JV04	1	1		YT02040150	Terminal
JV04			1	BY01050060	Jack
JV05	1	1	1	YT02020150	Terminal
JV06	1	1		YT02040210	Terminal
JV06			1	YT02040150	Terminal

• [P01-99] Front Chassis and General Parts

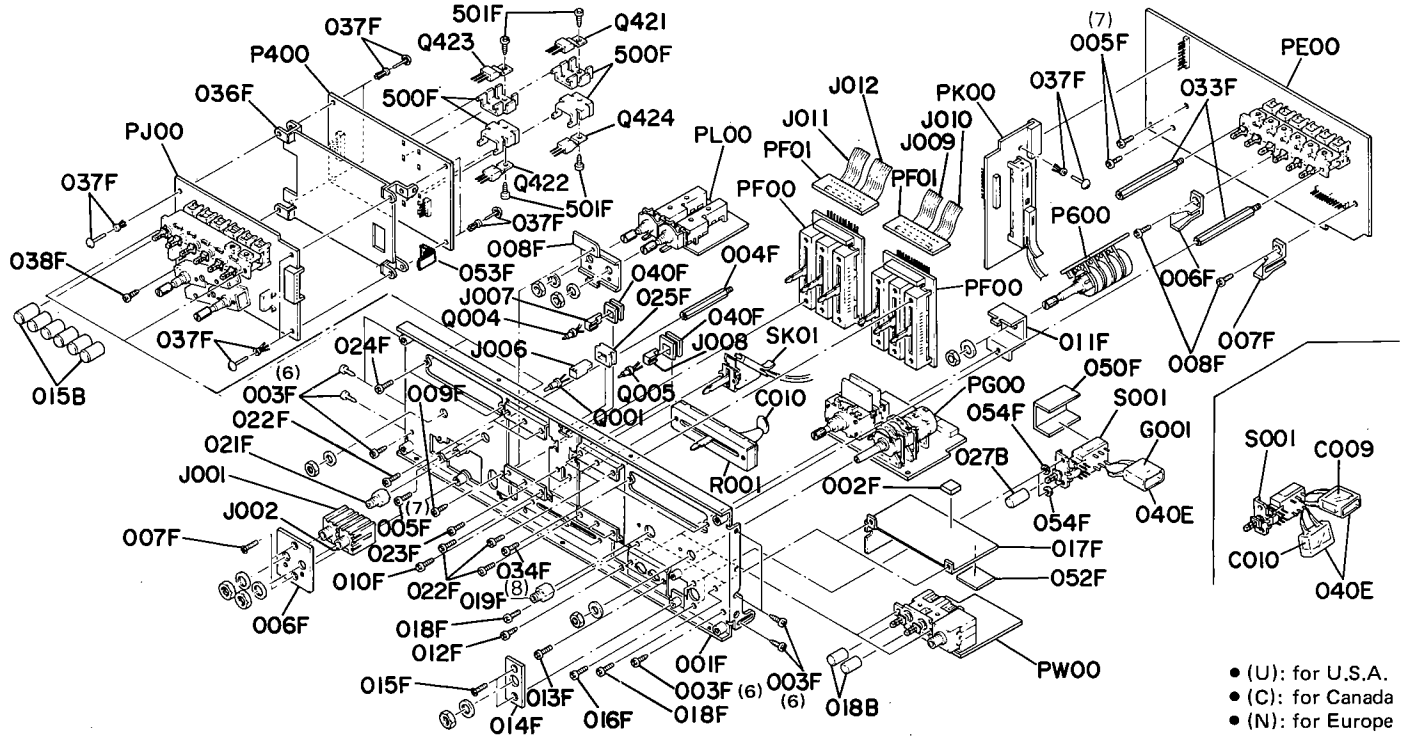

• (U): for U.S.A.
• (C): for Canada
• (N): for Europe

REF. DESIG.	Q'TY			PART NO.	DESCRIPTION
	U	C	N		
001F	1	1	1	2978160020	Bracket, Front
002F	1	1	1	3358118080	Spacer
003F	8	8	8	51280308B0	B.H. Tapped Screw B3x 8
004F	1	1	1	2978101050	Support
005F	1	1	1	51100306A9	B.H.M. Screw B3 x 6
006F	1	1	1	2978120050	Insulator
007F	2	2	2	51040306S9	F.H.M. Screw F3 x 6
008F	1	1	1	2978160080	Bracket
009F	1	1	1	51280308B0	B.H. Tapped Screw B3 x 8
010F	2	2	2	51100306A9	B.H.M. Screw B3 x 6
011F	1	1	1	2978160070	Bracket
012F	1	1	1	51280308B0	B.H. Tapped Screw B3 x 8
013F	2	2	2	51100306A9	B.H.M. Screw B3 x 6
014F	1	1	1	2970120020	Insulator
015F	2	2	2	51040306S9	F.H.M. Screw F3 x 6
016F	2	2	2	51100306A9	B.H.M. Screw B3 x 6
017F	1	1	1	2978109030	Shield
018F	2	2	2	51100306A9	B.H.M. Screw B3 x 6
019F	1	1	1	2978101020	Support
021F	1	1	1	2970101010	Support
022F	12	12	12	51100306A9	B.H.M. Screw B3 x 6
023F	2	2	2	51100306A9	B.H.M. Screw B3 x 6
024F	2	2	2	51100306A9	B.H.M. Screw B3 x 6
025F	1	1	1	2978259060	Bushing
033F	2	2	2	2978101050	Support
034F	2	2	2	51100306A9	B.H.M. Screw B3 x 6
036F	1	1	1	2978109050	Shield
037F	8	8	8	2276005050	Clamper
038F	1	1	1	51280306B0	B.H. Tapped Screw B3 x 6
040F	2	2	2	2978259060	Bushing
050F	1	1	1	3951120010	Insulator
052F	1	1	1	2978120070	Insulator
053F	1	1	1	2978120080	Insulator
054F	2	2	2	2232118300	Spacer

REF. DESIG.	Q'TY			PART NO.	DESCRIPTION
	U	C	N		
500F	4	4	4	2963267020	Heatsink
501F	4	4	4	51280306B0	B.H. Tapped Screw B3 x 6
015B	6	6	6	2970154030	Knob
018B	2	2	2	2970154030	Knob
027B	1	1	1	2221154120	Knob, Power Switch
040E	1	1		2219120010	Insulator
040E			2	3926120010	Insulator
005F	2	2	2	51280306B0	B.H. Tapped Screw B3 x 6
006F	1	1	1	2978051010	Guide
007F	1	1	1	2978051110	Guide
008F	1	1	1	51280310B0	B.H. Tapped Screw B3 x 10
C009			1	DF17223800	Film Cap. 0.022μF ±20% 1000V
C010			1	DF17223800	Film Cap. 0.022μF ±20% 1000V
C010	1	1	1	DK18473310	Ceramic Cap. 0.047μF +80 —20%
G001			1	BF10400030	Cap. Comp. 0.1μF + 120Ω
G001			1	BF10400050	Cap. Comp. 0.1μF + 120Ω
J001	1	1	1	YJ01001010	Jack, Dubbing In
J002	1	1	1	YJ01001010	Jack, Dubbing Out
J006	1	1	1	YJ05000250	Jack, L.E.D.
J007	1	1	1	YJ05000270	Jack, L.E.D.
J008	1	1	1	YJ05000250	Jack, L.E.D.
J009	1	1	1	YU08150210	Jumper Lead (8P)
J010	1	1	1	YU08150210	Jumper Lead (8P)
J011	1	1	1	YU08250210	Jumper Lead (8P)
J012	1	1	1	YU08250210	Jumper Lead (8P)
Q001	1	1	1	H110004030	L.E.D.
Q004	1	1	1	H110004030	L.E.D.
Q005	1	1	1	H110004030	L.E.D.
R001	1	1	1	RS01040110	Variable Resistor, 100KΩ (BH) x 2
S001	1	1		SP04010230	Push Switch, Power
S001			1	SP04010250	Push Switch, Power

• [C02-99] Main chassis and other parts

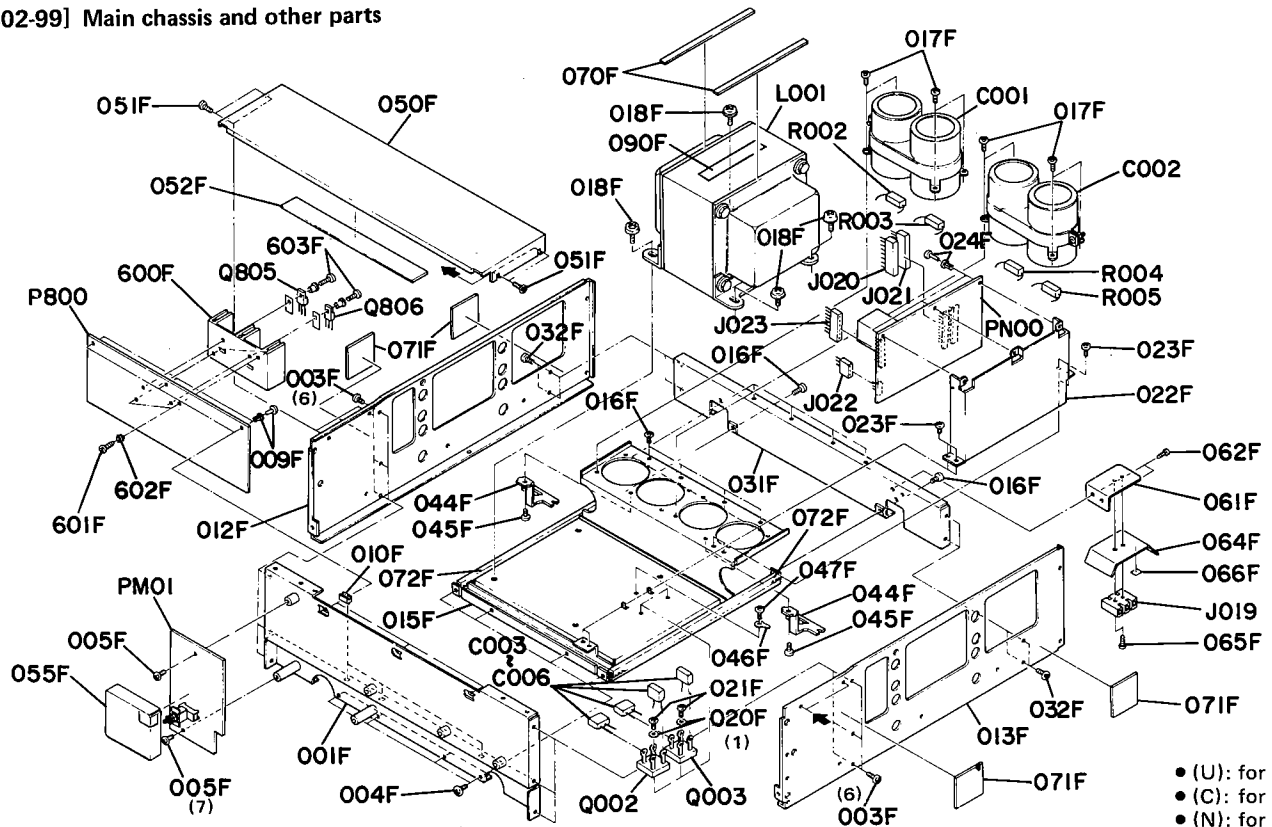

• (U): for U.S.A.
 • (C): for Canada
 • (N): for Europe

REF. DESIG.	Q'TY			PART NO.	DESCRIPTION
	U	C	N		
001F	1	1	1	2990160110	Bracket, Front Chassis
003F	6	6	6	51280408U0	B.H. Tapped Screw B4 x 8
004F	4	4	4	51280408B0	B.H. Tapped Screw B4 x 8
005F	2	2	2	51280306B0	B.H. Tapped Screw B3 x 6
009F	3	3	3	2965005010	Clamper
010F	3	3	3	2218271020	Holder
012F	1	1	1	2990160030	Bracket, (L)
013F	1	1	1	2990160130	Bracket, (R)
015F	1	1	1	2979105010	Chassis, Main
016F	6	6	6	51280408B0	B.H. Tapped Screw B4 x 8
017F	8	8	8	51280308B0	B.H. Tapped Screw B3 x 8
018F	4	4	4	51490612A9	L. Washer Screw L6 x 12
020F	2	2	2	54020301A0	Flat Washer, P
021F	2	2	2	51280316B0	B.H. Tapped Screw B3 x 16
022F	1	1	1	2979160010	Bracket
023F	4	4	4	51280306B0	B.H. Tapped Screw B3 x 6
024F	3	3	3	2965005010	Clamper
031F	1	1	1	2990160020	Bracket
032F	4	4	4	51280408U0	B.H. Tapped Screw B4 x 8
044F	2	2	2	2979160040	Bracket
045F	2	2	2	51280308B0	B.H. Tapped Screw B3 x 8
046F	1	1	1	62030049W0	Lug
047F	1	1	1	51280306B0	B.H. Tapped Screw B3 x 6
050F	1	1	1	2990053010	Cover
051F	4	4	4	51280306U0	B.H. Tapped Screw B3 x 6
052F	1	1	1	2978120010	Insulator
055F	1	1	1	2978053050	Cover
061F	1	1	1	2990271010	Holder
062F	2	2	2	51280308B0	B.H. Tapped Screw B3 x 8
064F	1	1	1	3953120030	Insulator
065F	2	2	2	51280314B0	B.H. Tapped Screw B3 x 14
066F	1	1	1	2882861020	Label

REF. DESIG.	Q'TY			PART NO.	DESCRIPTION
	U	C	N		
070F	2	2	2	2979056010	Buffer
071F	4	4	4	2979056020	Buffer
072F	2	2	2	2979259050	Bushing
090F	1	1	1	2213861010	Label
600F	1	1	1	2990267020	Heatsink
601F	2	2	2	51280306B0	B.H. Tapped Screw B3 x 6
602F	2	2	2	54050300R0	T.L. Washer OR
603F	2	2	2	51280308B0	B.H. Tapped Screw B3 x 8
C001	1	1	1	EI10908040	Elect Cap. 10000µF
C002	1	1	1	EI10908040	Elect Cap. 10000µF
C003	1	1	1	DK18103510	Ceramic Cap. 0.01µF 500V
C004	1	1	1	DK18103510	Ceramic Cap. 0.01µF 500V
C005	1	1	1	DK18103510	Ceramic Cap. 0.01µF 500V
C006	1	1	1	DK18103510	Ceramic Cap. 0.01µF 500V
J019			1	YL09030010	Terminal, (3P)
J020	1	1	1	YJ06001070	Jack, (9P)
J021	1	1	1	YJ06001070	Jack, (9P)
J022	1	1	1	YJ06001040	Jack, (3P)
J023	1	1	1	YJ06001060	Jack, (7P)
L001	1	1	1	TS63303040	Power Transformer
L001	1	1	1	TS63303050	Power Transformer
Q002	1	1	1	HD20004290	Diode S5VB-20
Q003	1	1	1	HD20004290	Diode S5VB-20
R002	1	1	1	GS10222030	Resistor 2.2KΩ ±10% 3W
R003	1	1	1	GS10222030	Resistor 2.2KΩ ±10% 3W
R004	1	1	1	GS10222030	Resistor 2.2KΩ ±10% 3W
R005	1	1	1	GS10222030	Resistor 2.2KΩ ±10% 3W
Q805	1	1	1	HT403132P0	Transistor 2SD313 (D or E)
Q806	1	1	1	HT205072P0	Transistor 2SB507 (D or E)

• [C02-99] Main Chassis and Other Parts

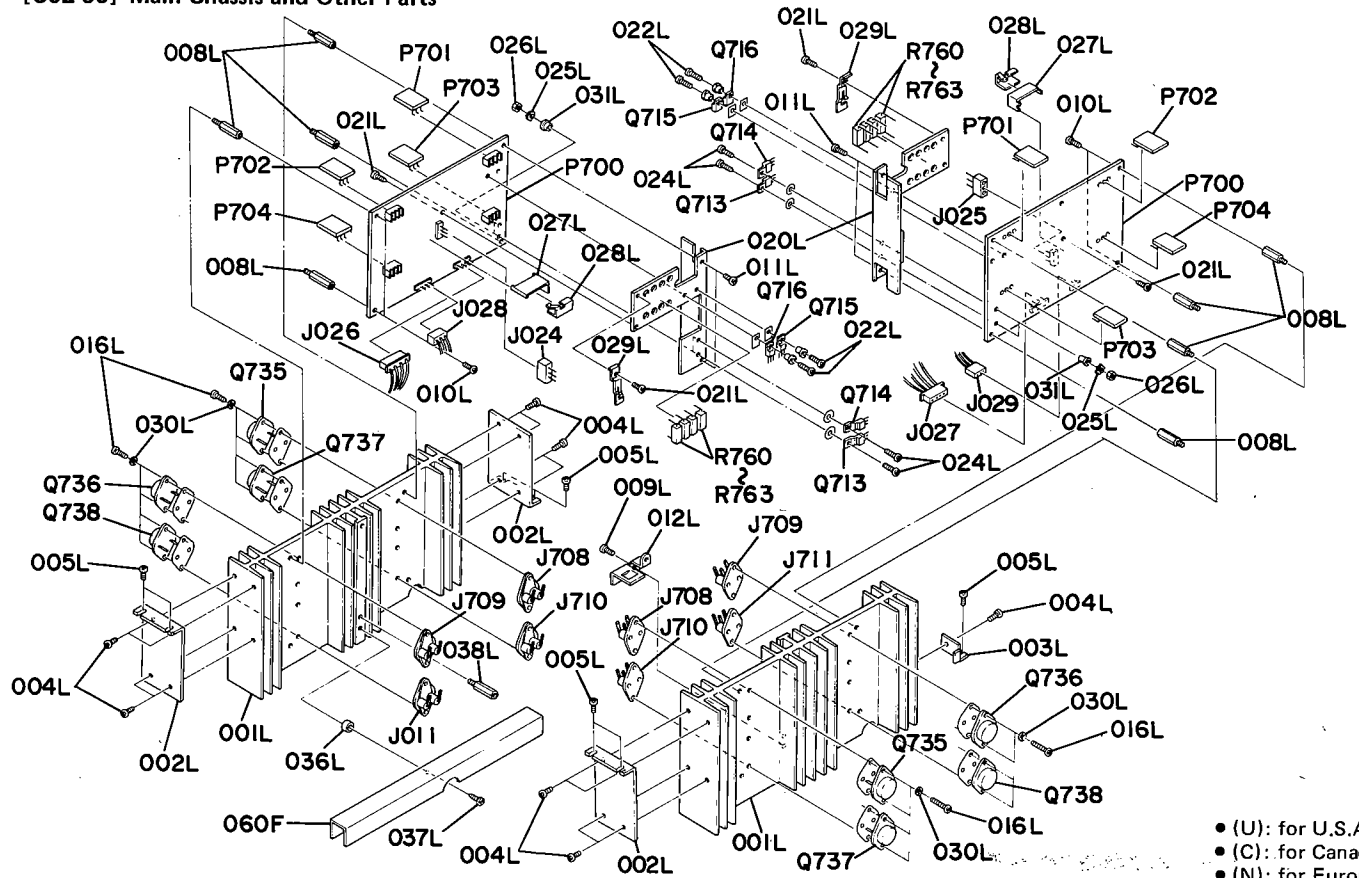

• (U): for U.S.A.
 • (C): for Canada
 • (N): for Europe

REF. DESIG.	Q'TY			PART NO.	DESCRIPTION
	U	C	N		
001L	2	2	2	2463267010	Heatsink
002L	3	3	3	2979160020	Bracket
003L	1	1	1	2978104030	Retainer
004L	13	13	13	51280308B0	B.H. Tapped Screw B3 x 8
005L	7	7	7	51280306B0	B.H. Tapped Screw B3 x 6
008L	8	8	8	2463101010	Support
009L	1	1	1	51100306A9	B.H.M. Screw B3 x 6
010L	6	6	6	51100306A9	B.H.M. Screw B3 x 6
011L	4	4	4	51100308A9	B.H.M. Screw B3 x 8
012L	1	1	1	2990104060	Retainer
016L	16	16	16	51100316A9	B.H.M. Screw B3 x 16
020L	2	2	2	2990267030	Heatsink
021L	4	4	4	51280306B0	B.H. Tapped Screw B3 x 6
022L	4	4	4	51100308E9	B.H.M. Screw B3 x 8
024L	4	4	4	51100312E9	B.H.M. Screw B3 x 12
025L	4	4	4	54050300R0	T.L. Washer OR
026L	4	4	4	53110303E9	Hexagon Nut
027L	2	2	2	2990267080	Heatsink
028L	2	2	2	2990115020	Spring
029L	2	2	2	2990115010	Spring
030L	16	16	16	54040302N0	Spring Washer
031L	4	4	4	2219259030	Bushing
037L	1	1	1	51100310A9	B.H.M. Screw B3 x 10
038L	1	1	1	2891101030	Support
036L	1	1	1	3683055010	Collar
060F	1	1	1	2990109010	Shield

REF. DESIG.	Q'TY			PART NO.	DESCRIPTION
	U	C	N		
J024	1	1	1	YJ06001040	Jack, (3P)
J025	1	1	1	YJ06001040	Jack, (3P)
J026	1	1	1	YJ06002050	Jack, (4P)
J027	1	1	1	YJ06002060	Jack, (4P)
J028	1	1	1	YJ06001040	Jack, (3P)
J029	1	1	1	YJ06001040	Jack, (3P)
P700	2	2	2	YK29901610	P.W. Board, Main
	2	2	2	ZZ29901610	P.W. Board Assembly
R760	2	2	2	GW10272050	Resistor 0.27Ω ±10% 5W
R761	2	2	2	GW10272050	Resistor 0.27Ω ±10% 5W
R762	2	2	2	GW10272050	Resistor 0.27Ω ±10% 5W
R763	2	2	2	GW10272050	Resistor 0.27Ω ±10% 5W
Q713	2	2	2	HT407571C0	Transistor 2SD757 (C)
Q714	2	2	2	HT407571C0	Transistor 2SD757 (C)
Q715	2	2	2	HT322381C0	Transistor 2SC2238B (O or Y)
Q716	2	2	2	HT322381C0	Transistor 2SC2238B (O or Y)
Q735	2	2	2	HT406652A0	Transistor 2SD665 (R or O)
Q736	1	1	1	HT206452A0	Transistor 2SB645 (R or O)
Q737	2	2	2	HT406652A0	Transistor 2SD665 (R or O)
Q738	2	2	2	HT206452A0	Transistor 2SB645 (R or O)
J708	2	2	2	YJ05000260	Jack
J709	2	2	2	YJ05000260	Jack
J710	2	2	2	YJ05000260	Jack
J711	2	2	2	YJ05000260	Jack

● [H01-99] Packing Materials

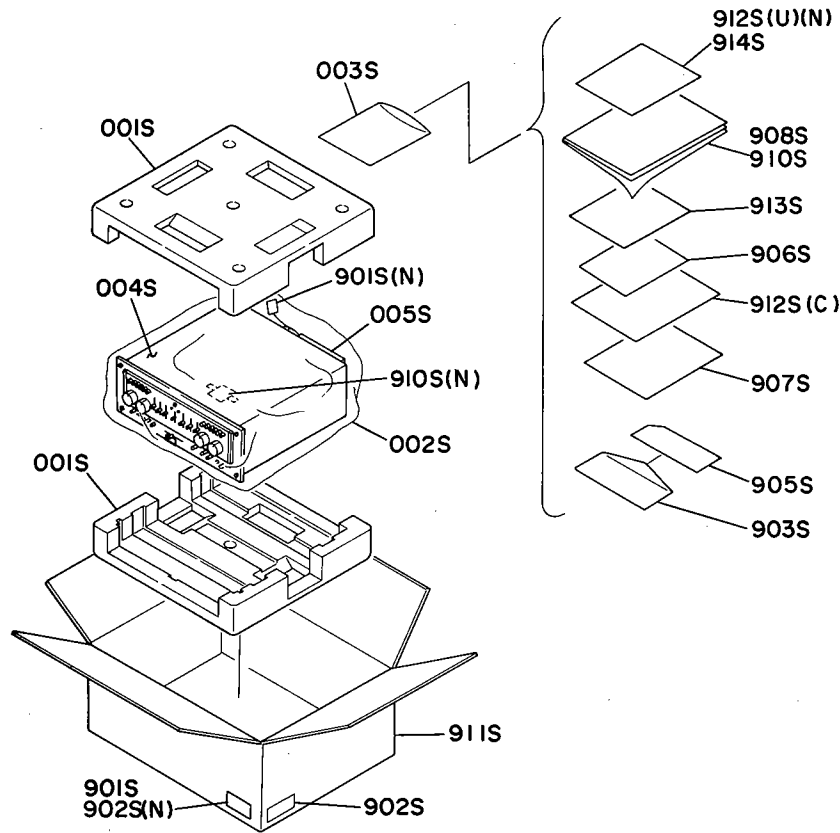

- (U): for U.S.A.
- (C): for Canada
- (N): for Europe

REF. DESIG.	Q'TY			PART NO.	DESCRIPTION
	U	C	N		
001S	2	2	2	2990809010	Cushion
002S	1	1		9091111040	Polyethy Sheet
002S			1	9014538450	Polyethy Bag
003S	1	1	1	9013025010	Polyethy Bag
004S	1	1	1	2918107210	Sheet
005S	1	1	1	2864804010	Sleeve
901S	3			9526019010	Serial No. Card
901S		3		9526019020	Serial No. Card
901S			1	9560000040	Hang Tag
902S		2		9510901020	Label
902S			3	9526019060	Serial No. Card
903S			1	2818813010	Envelope
903S		1		2918813010	Envelope
905S		1	1	9630000180	Guarantee Card
906S			1	9650000050	S. Station Card
907S	1			2818854020	Guarantee Card

REF. DESIG.	Q'TY			PART NO.	DESCRIPTION
	U	C	N		
907S			1	2818854040	Guarantee Card
908S			1	2990851310	Instructions
910S			1	2731821010	Silicagel
910S	1			2990851010	Instructions
910S		1		2990851310	Instructions
911S	1		1	2990801010	Packing Case
911S		1		2990801150	Packing Case
912S			1	2886851100	Instructions
912S	1			2990851020	Instructions
912S			1	2990851030	Instructions
913S	1			2225813010	Envelope
914S		1		2990851050	Instructions

8. ELECTRICAL PARTS LIST

• (U): for U.S.A.
 • (C): for Canada
 • (N): for Europe

REF. DESIG.	Q'TY			PART NO.	DESCRIPTION
	U	C	N		
P400	1	1	1	YG29780020 ZZ29781010	P400-PHONE AMP. CIRCUIT BOARD P.W. Board, Phono Amp. P.W. Board Assembly
P400-CAPACITORS					
C403	1	1	1	DF55681090	Film 680pF ±5%
C404	1	1	1	DF55681090	Film 680pF ±5%
C405	1	1	1	DF55681090	Film 680pF ±5%
C406	1	1	1	DF55681090	Film 680pF ±5%
C407	1	1	1	DF55681090	Film 680pF ±5%
C408	1	1	1	DF55681090	Film 680pF ±5%
C409	1	1	1	EA47503590	Elect 4.7µF 35V
C410	1	1	1	EA47503590	Elect 4.7µF 35V
C411	1	1	1	EQ10603510	Elect 10µF 35V
C412	1	1	1	EQ10603510	Elect 10µF 35V
C413	1	1	1	DF74103010	Film 0.01µF ±2%
C414	1	1	1	DF74103010	Film 0.01µF ±2%
C415	1	1	1	DF74333010	Film 0.033µF ±2%
C416	1	1	1	DF74333010	Film 0.033µF ±2%
C417	1	1	1	EA22703590	Elect 220µF 35V
C418	1	1	1	EA22703590	Elect 220µF 35V
C419	1	1	1	DF17474510	Film 0.47µF ±20% 250V
C420	1	1	1	DF17474510	Film 0.47µF ±20% 250V
C421	1	1	1	DF15222300	Film 0.0022µF ±5%
C422	1	1	1	DF15222300	Film 0.0022µF ±5%
C423	1	1	1	EA22701090	Elect 220µF 10V
C424	1	1	1	EA22701090	Elect 220µF 10V
C425	1	1	1	DF15103300	Film 0.01µF ±5%
C426	1	1	1	DF15103300	Film 0.01µF ±5%
C427	1	1	1	DF15103300	Film 0.01µF ±5%
C428	1	1	1	DF15103300	Film 0.01µF ±5%
C431	1	1	1	DF15472300	Film 0.0047µF ±5%
C432	1	1	1	DF15472300	Film 0.0047µF ±5%
C433	1	1	1	DD15470300	Ceramic 47pF ±5%
C434	1	1	1	DD15470300	Ceramic 47pF ±5%
C435	1	1	1	DD15470300	Ceramic 47pF ±5%
C436	1	1	1	DD15470300	Ceramic 47pF ±5%
C437	1	1	1	DK18473310	Ceramic 0.047µF +100% -0
C438	1	1	1	DK18473310	Ceramic 0.047µF +100% -0
P400-RESISTORS (All Resistors are ±5% and ¼W)					
R401	1	1	1	GD05101140	100Ω
R402	1	1	1	GD05101140	100Ω
R403	1	1	1	GD05104140	100KΩ
R404	1	1	1	GD05104140	100KΩ
R405	1	1	1	GM21426710	2.67KΩ ±2%
R406	1	1	1	GM21426710	2.67KΩ ±2%
R407	1	1	1	GM21426710	2.67KΩ ±2%
R408	1	1	1	GM21426710	2.67KΩ ±2%
R409	1	1	1	GD05471140	470Ω
R410	1	1	1	GD05471140	470Ω
R411	1	1	1	GD05471140	470Ω
R412	1	1	1	GD05471140	470Ω
R413	1	1	1	GD05621140	620Ω
R414	1	1	1	GD05621140	620Ω
R415	1	1	1	GD05272140	2.7KΩ
R416	1	1	1	GD05272140	2.7KΩ
R417	1	1	1	GD05272140	2.7KΩ
R418	1	1	1	GD05272140	2.7KΩ
R419	1	1	1	GD05122140	1.2KΩ
R420	1	1	1	GD05122140	1.2KΩ

REF. DESIG.	Q'TY			PART NO.	DESCRIPTION
	U	C	N		
R421	1	1	1	GD05122140	1.2KΩ
R422	1	1	1	GD05122140	1.2KΩ
R423	1	1	1	GG05680140	68Ω
R424	1	1	1	GG05680140	68Ω
R425	1	1	1	GG05680140	68Ω
R426	1	1	1	GG05680140	68Ω
R427	1	1	1	GD05101140	100Ω
R428	1	1	1	GD05101140	100Ω
R429	1	1	1	GG05120140	12Ω
R430	1	1	1	GG05120140	12Ω
R431	1	1	1	GG05120140	12Ω
R432	1	1	1	GG05120140	12Ω
R433	1	1	1	GD05393140	39KΩ
R434	1	1	1	GD05393140	39KΩ
R435	1	1	1	GM21413000	130Ω ±2%
R436	1	1	1	GM21413000	130Ω ±2%
R437	1	1	1	GM21475010	7.5KΩ ±2%
R438	1	1	1	GM21475010	7.5KΩ ±2%
R439	1	1	1	GD05101140	100Ω
R440	1	1	1	GD05101140	100Ω
R441	1	1	1	GM21490920	90.9KΩ ±2%
R442	1	1	1	GM21490920	90.9KΩ ±2%
R443	1	1	1	GD05472140	4.7KΩ
R444	1	1	1	GD05472140	4.7KΩ
R445	1	1	1	GD05101140	100Ω
R446	1	1	1	GD05101140	100Ω
R447	1	1	1	GD05104140	100KΩ
R448	1	1	1	GD05104140	100KΩ
R449	1	1	1	GG05470140	47Ω
R450	1	1	1	GG05470140	47Ω
R451	1	1	1	GD05224140	220KΩ
R452	1	1	1	GD05224140	220KΩ
R453	1	1	1	GD05683140	68KΩ
R454	1	1	1	GD05683140	68KΩ
R455	1	1	1	GD05222140	2.2KΩ
R456	1	1	1	GD05222140	2.2KΩ
P400-SEMICONDUCTORS					
Q401	1	1	1	HF201361Q0	F.E.T. 2SK136 (Q)
Q402	1	1	1	HF201361Q0	F.E.T. 2SK136 (Q)
Q403	1	1	1	HF201361Q0	F.E.T. 2SK136 (Q)
Q404	1	1	1	HF201361Q0	F.E.T. 2SK136 (Q)
Q405	1	1	1	HT322401B0	Transistor 2SC2240 (BL)
Q406	1	1	1	HT322401B0	Transistor 2SC2240 (BL)
Q407	1	1	1	HT109701B0	Transistor 2SA970 (BL)
Q408	1	1	1	HT109701B0	Transistor 2SA970 (BL)
Q409	1	1	1	HT109701B0	Transistor 2SA970 (BL)
Q410	1	1	1	HT109701B0	Transistor 2SA970 (BL)
Q411	1	1	1	HT322401A0	Transistor 2SC2240 (GR)
Q412	1	1	1	HT322401A0	Transistor 2SC2240 (GR)
Q413	1	1	1	HT108722D0	Transistor 2SA872A (D or E)
Q414	1	1	1	HT108722D0	Transistor 2SA872A (D or E)
Q415	1	1	1	HT317752D0	Transistor 2SC1775A (D or E)
Q416	1	1	1	HT317752D0	Transistor 2SC1775A (D or E)
Q417	1	1	1	HT317752D0	Transistor 2SC1775A (D or E)
Q418	1	1	1	HT317752D0	Transistor 2SC1775A (D or E)
Q419	1	1	1	HT108722D0	Transistor 2SA872A (D or E)
Q420	1	1	1	HT108722D0	Transistor 2SA872A (D or E)

- (U): for U.S.A.
- (C): for Canada
- (N): for Europe

REF. DESIG.	Q'TY			PART NO.	DESCRIPTION
	U	C	N		
Q421	1	1	1	HT407571C0	Transistor 2SD757 (C)
Q422	1	1	1	HT407571C0	Transistor 2SD757 (C)
Q423	1	1	1	HT207171C0	Transistor 2SB717 (C)
Q424	1	1	1	HT207171C0	Transistor 2SB717 (C)
Q425	1	1	1	HV00002060	Varistor VD1212
Q426	1	1	1	HV00002060	Varistor VD1212
Q427	1	1	1	HD20003210	Diode 1S2471
Q428	1	1	1	HD20003210	Diode 1S2471
Q429	1	1	1	HD20003210	Diode 1S2471
Q430	1	1	1	HD20003210	Diode 1S2471
Q431	1	1	1	HD20003210	Diode 1S2471
Q432	1	1	1	HD20003210	Diode 1S2471
Q433	1	1	1	HV00006120	Varistor MV203 (Y)
Q434	1	1	1	HV00006120	Varistor MV203 (Y)
Q435	1	1	1	HV00004060	Varistor VD1210
Q436	1	1	1	HV00004060	Varistor VD1210
Q437	1	1	1	HD20003210	Diode 1S2471
Q439	1	1	1	HT322401B0	Transistor 2SC2240 (BL)
Q440	1	1	1	HT322401B0	Transistor 2SC2240 (BL)
Q441	1	1	1	HT322401B0	Transistor 2SC2240 (BL)
Q442	1	1	1	HT322401B0	Transistor 2SC2240 (BL)
P400-MISCELLANEOUS					
J401	1	1	1	YP06001650	Plug (10P)
J402	1	1	1	YP06001650	Plug (6P)
L401	1	1	1	LY20240120	Relay
P600-LOUDNESS CONTOUR CIRCUIT BOARD					
P600	1	1	1	YH29781220	P.W. Board, Loudness Contour
	1	1	1	ZZ29781220	P.W. Board Assembly
P600-CAPACITORS					
C601	1	1	1	DF15104300	Film 0.1 μ F \pm 5%
C602	1	1	1	DF15104300	Film 0.1 μ F \pm 5%
C603	1	1	1	DF15222300	Film 0.0022 μ F \pm 5%
C604	1	1	1	DF15222300	Film 0.0022 μ F \pm 5%
P600-RESISTORS					
R601	1	1	1	RG050300800	Variable, 250K Ω x 2, 50K Ω x 2
R602	1	1	1	GD05153140	15K Ω \pm 5% $\frac{1}{4}$ W
R603	1	1	1	GD05153140	15K Ω \pm 5% $\frac{1}{4}$ W
R604	1	1	1	GD05332140	3.3K Ω \pm 5% $\frac{1}{4}$ W
R605	1	1	1	GD05332140	3.3K Ω \pm 5% $\frac{1}{4}$ W
P700-MAIN AMP. CIRCUIT BOARD					
P700	2	2	2	YK29901610	P.W. Board, Main Amp.
	2	2	2	ZZ29901610	P.W. Board Assembly
P700-CAPACITORS					
C701	2	2	2	DD15221370	Ceramic 220pF \pm 5%
C702	2	2	2	EA10602590	Elect 10 μ F 25V
C703	2	2	2	EA10602590	Elect 10 μ F 25V
C704	2	2	2	DD15121370	Ceramic 120pF \pm 5%
C705	2	2	2	DK16101500	Ceramic 100pF \pm 10% 500V
C708	2	2	2	DD15100500	Ceramic 10pF \pm 5% 500V
C709	2	2	2	EA10605090	Elect 10 μ F 50V
C710	2	2	2	DF17104540	Film 0.1 μ F \pm 20% 100V
C711	2	2	2	DF17104540	Film 0.1 μ F \pm 20% 100V
C712	2	2	2	DF17104540	Film 0.1 μ F \pm 20% 100V

REF. DESIG.	Q'TY			PART NO.	DESCRIPTION
	U	C	N		
C713	2	2	2	DF17104540	Film 0.1 μ F \pm 20% 100V
C714	2	2	2	DF16472350	Film 0.0047 μ F \pm 10%
C715	2	2	2	DF16472350	Film 0.0047 μ F \pm 10%
C716	2	2	2	EA33502590	Elect 3.3 μ F 25V
C717	2	2	2	EA33502590	Elect 3.3 μ F 25V
C718	2	2	2	DF17103510	Film 0.01 μ F \pm 20% 200V
C719	2	2	2	DF17104510	Film 0.1 μ F \pm 20% 200V
C720	2	2	2	DF17474510	Film 0.47 μ F \pm 20% 200V
C721	2	2	2	DF17474510	Film 0.47 μ F \pm 20% 200V
C722	2	2	2	EA10710010	Elect 100 μ F 100V
C723	2	2	2	EA10710010	Elect 100 μ F 100V
P700-RESISTORS					
(All Resistors are \pm 5% and $\frac{1}{4}$ W)					
R701	2	2	2	GD05474140	470K Ω
R702	2	2	2	GD05471140	470 Ω
R703	2	2	2	GD05104140	100K Ω
R704	2	2	2	GD05561140	560 Ω
R705	2	2	2	GD05561140	560 Ω
R708	2	2	2	GD05203140	20K Ω
R709	2	2	2	GD05102140	1K Ω
R710	2	2	2	GD05181140	180 Ω
R711	2	2	2	GD05102140	1K Ω
R712	2	2	2	GD05222140	2.2K Ω
R713	2	2	2	GD05222140	2.2K Ω
R714	2	2	2	GD05391140	390 Ω
R715	2	2	2	GD05104140	100K Ω
R716	2	2	2	GD05822140	8.2K Ω
R717	2	2	2	GD05822140	8.2K Ω
R718	2	2	2	GD05272140	2.7K Ω
R719	2	2	2	GD05272140	2.7K Ω
R720	2	2	2	RA02230050	Trimming 22K Ω (B)
R721	2	2	2	GA05562010	5.6K Ω 1W
R722	2	2	2	GA05472010	4.7K Ω 1W
R723	2	2	2	GD05222140	2.2K Ω
R724	2	2	2	GD05222140	2.2K Ω
R725	2	2	2	GD05222140	2.2K Ω
R726	2	2	2	GD05222140	2.2K Ω
R727	2	2	2	GD05563140	56K Ω
R728	2	2	2	GD05563140	56K Ω
R729	2	2	2	GG05331140	330 Ω
R730	2	2	2	GG05331140	330 Ω
R731	2	2	2	GD05332140	3.3K Ω
R732	2	2	2	GD05681140	680 Ω
R733	2	2	2	RA01020270	Trimming 1K Ω (B)
R734	2	2	2	GD05821140	820 Ω
R735	2	2	2	GG05330140	33 Ω
R736	2	2	2	GG05330140	33 Ω
R737	2	2	2	GG05100140	10 Ω
R738	2	2	2	GG05100140	10 Ω
R739	2	2	2	GD05122140	1.2K Ω
R740	2	2	2	GD05273140	27K Ω
R741	2	2	2	GD05331140	330 Ω
R742	2	2	2	GD05331140	330 Ω
R743	2	2	2	GD05682140	6.8K Ω
R744	2	2	2	GD05682140	6.8K Ω
R745	2	2	2	GD05911140	910 Ω
R746	2	2	2	GD05911140	910 Ω
R747	2	2	2	GD05911140	910 Ω

• (U): for U.S.A.
 • (C): for Canada
 • (N): for Europe

REF. DESIG.	Q'TY			PART NO.	DESCRIPTION
	U	C	N		
R748	2	2	2	GD05911140	910Ω
R749	2	2	2	GD05203140	20KΩ
R750	2	2	2	GA05331120	330Ω 1/2W
R751	2	2	2	GA05560010	56Ω 1W
R752	2	2	2	GG05100120	10Ω 1/2W
R753	2	2	2	GG05100120	10Ω 1/2W
R754	2	2	2	GG05100120	10Ω 1/2W
R755	2	2	2	GG05100120	10Ω 1/2W
R756	2	2	2	GG05047140	4.7Ω
R757	2	2	2	GG05047140	4.7Ω
R758	2	2	2	GG05047140	4.7Ω
R759	2	2	2	GG05047140	4.7Ω
R760	2	2	2	GW10272050	0.27Ω ±10% 5W
R761	2	2	2	GW10272050	0.27Ω ±10% 5W
R762	2	2	2	GW10272050	0.27Ω ±10% 5W
R763	2	2	2	GW10272050	0.27Ω ±10% 5W
R764	2	2	2	GA05100030	10Ω 3W
R765	2	2	2	GA05022020	2.2Ω 2W
R766	2	2	2	GA05100010	10Ω 1W
P700-SEMICONDUCTORS					
Q701	2	2	2	HC10003200	IC 2SK109 (C or D)
Q702	2	2	2	HT322592F0	Transistor 2SC2259 (F or G)
Q703	2	2	2	HT109701A0	Transistor 2SA970 (GR)
Q704	2	2	2	HT322401J0	Transistor 2SC2240 (GR)
Q705	2	2	2	HT109701A0	Transistor 2SA970 (GR)
Q706	2	2	2	HT109701J0	Transistor 2SA970 (GR)
Q707	2	2	2	HT322401J0	Transistor 2SC2240 (GR)
Q708	2	2	2	HT109491B0	Transistor 2SA949 (Y)
Q709	2	2	2	HT322291B0	Transistor 2SC2229 (Y)
Q710	2	2	2	HT109701B0	Transistor 2SA970 (BL)
Q711	2	2	2	HT318152A0	Transistor 2SC1815 (O or Y)
Q712	2	2	2	HT110152A0	Transistor 2SA1015 (O or Y)
Q713	2	2	2	HT407571C0	Transistor 2SD757 (C)
Q714	2	2	2	HT207171C0	Transistor 2SB717 (C)
Q715	2	2	2	HT322381C0	Transistor 2SC2238B (O or Y)
Q716	2	2	2	HT109681C0	Transistor 2SA968B (O or Y)
Q717	2	2	2	HD30025090	Zener WZ150
Q718	2	2	2	HD30025090	Zener WZ150
Q719	2	2	2	HD20003210	Diode 1S2471
Q720	2	2	2	HD20003210	Diode 1S2471
Q721	2	2	2	HD20003210	Diode 1S2471
Q722	2	2	2	HD20003210	Diode 1S2471
Q723	2	2	2	HD20010210	Diode 1S2471G
Q724	2	2	2	HD20010210	Diode 1S2471G
Q725	2	2	2	HV00002120	Varistor SV-3A
Q726	2	2	2	HD20001210	Diode 1S2473
Q727	2	2	2	HD20001210	Diode 1S2473
Q728	2	2	2	HD20003210	Diode 1S2471
Q729	2	2	2	HD20003210	Diode 1S2471
Q730	2	2	2	HD20003210	Diode 1S2471
Q731	2	2	2	HD20003210	Diode 1S2471
Q732	2	2	2	HD20011010	Diode W06C
Q733	2	2	2	HD20011010	Diode W06C
Q734	2	2	2	HT315681S0	Transistor 2SC1568 (S)
Q735	2	2	2	HT406652A0	Transistor 2SD665 (R or O)
Q736	2	2	2	HT206452A0	Transistor 2SB645 (R or O)
Q737	2	2	2	HT406652A0	Transistor 2SD665 (R or O)
Q738	2	2	2	HT206452A0	Transistor 2SB645 (R or O)
Q739	2	2	2	HD20001210	Diode 1S2473
Q740	2	2	2	HD20001210	Diode 1S2473

REF. DESIG.	Q'TY			PART NO.	DESCRIPTION
	U	C	N		
P700-MISCELLANEOUS					
J701	2	2	2	YP06001040	Plug, (3P)
J702	2	2	2	YP06000520	Plug, (4P)
J703	2	2	2	YP06001040	Plug, (3P)
J704	2	2	2	YJ06001960	Jack, (3P)
J705	2	2	2	YJ06001960	Jack, (3P)
J706	2	2	2	YJ06001960	Jack, (3P)
J707	2	2	2	YJ06001960	Jack, (3P)
J708	2	2	2	YJ05000260	Jack, TR. Socket
J709	2	2	2	YJ05000260	Jack, TR. Socket
J710	2	2	2	YJ05000260	Jack, TR. Socket
J711	2	2	2	YJ05000260	Jack, TR. Socket
L701	2	2	2	LL23915120	Choke Coil 0.8μH
P701	2	2	2	YK29901620	P.W. Board, Power Tr. Socket
	2	2	2	ZZ29901620	P.W. Board Assembly
J712	2	2	2	YP06001640	Plug, (3P)
P702	2	2	2	YK29901630	P.W. Board, Power Tr. Socket
	2	2	2	ZZ29901630	P.W. Board Assembly
J713	2	2	2	YP06001640	Plug, (3P)
P703	2	2	2	YK29901640	P.W. Board, Power Tr. Socket
	2	2	2	ZZ29901640	P.W. Board Assembly
J714	2	2	2	YP06001640	Plug, (3P)
P704	2	2	2	YK29901650	P.W. Board, Power Tr. Socket
	2	2	2	ZZ29901650	P.W. Board Assembly
J715	2	2	2	YP06001640	Plug, (3P)
P800-POWER SUPPLY CIRCUIT BOARD					
P800	1	1	1	YF29900040	P.W. Board, Power Supply
	1	1	1	ZZ29900040	P.W. Board Assembly
			1	ZZ29908040	P.W. Board Assembly
P800-CAPACITORS					
C801	1	1	1	DK18103510	Ceramic 0.01μF 500V
C802	1	1	1	DK18103510	Ceramic 0.01μF 500V
C803	1	1	1	DF17474510	Film 0.47μF ±20% 250V
C804	1	1	1	DF17474510	Film 0.47μF ±20% 250V
C805	1	1	1	EB10805060	Elect 1000μF 50V
C806	1	1	1	EB10805060	Elect 1000μF 50V
C807	1	1	1	DF15103350	Film 0.01μF ±5%
C808	1	1	1	DF15103350	Film 0.01μF ±5%
C809	1	1	1	EA10701090	Elect 100μF 10V
C810	1	1	1	EA47503590	Elect 4.7μF 35V

- (U): for U.S.A.
- (C): for Canada
- (N): for Europe

REF. DESIG.	Q'TY			PART NO.	DESCRIPTION
	U	C	N		
C811	1	1	1	EA47503590	Elect 4.7 μ F 35V
C812	1	1	1	EA10803590	Elect 1000 μ F 35V
C813	1	1	1	EA10803590	Elect 1000 μ F 35V
C814	1	1	1	DF17474510	Film 0.47 μ F \pm 20% 250V
C815	1	1	1	DF17474510	Film 0.47 μ F \pm 20% 250V
P800-RESISTORS					
(All Resistors are \pm 5% and $\frac{1}{4}$ W)					
R803	1	1	1	GD05102140	1K Ω
R804	1	1	1	GD05102140	1K Ω
R807	1	1	1	GG05682120	6.8K Ω $\frac{1}{2}$ W
R808	1	1	1	GD05473140	47K Ω
R809	1	1	1	GD05103140	10K Ω
R810	1	1	1	RA04720050	Trimming 4.7K Ω (B)
R811	1	1	1	GD05473140	47K Ω
R812	1	1	1	GD05473140	47K Ω
R813	1	1	1	GD05162140	1.6K Ω
R814	1	1	1	GG05151140	150 Ω
R815	1	1	1	GG05151140	150 Ω
P800-SEMICONDUCTORS					
Q801	1	1	1	HF200301C0	F.E.T. 2SK30A (Y)
Q802	1	1	1	HF200301C0	F.E.T. 2SK30A (Y)
Q803	1	1	1	HT315091Q0	Transistor 2SC1509 (Q)
Q804	1	1	1	HT107771Q0	Transistor 2SA777 (Q)
Q805	1	1	1	HT403132P0	Transistor 2SD313 (D or E)
Q806	1	1	1	HT205072P0	Transistor 2SB507 (D or E)
Q807	1	1	1	HT322402A0	Transistor 2SC2240 (GR or BL)
Q808	1	1	1	HT109702A0	Transistor 2SA970 (GR or BL)
Q809	1	1	1	HE10001030	Diode DS133B
Q810	1	1	1	HE10001030	Diode DS133B
Q811	1	1	1	HD30008010	Zener HZ-6L (B)
P800-MISCELLANEOUS					
F801	1	1		FS10100080	Fuse 1A
F801			1	FS10100800	Fuse 1AT
F802	1	1		FS10100080	Fuse 1A
F802			1	FS10100800	Fuse 1AT
J801	}	4	4	YJ08000170	Jack, Fuse Holder
J804					
J801	}	4	4	YJ08000270	Jack, Fuse Holder
J804					
PE00-PRE AMP. CIRCUIT BOARD					
PE00	1	1	1	YN29782210	P.W. Board, Pre Amp.
	1	1	1	ZZ29781040	P.W. Board Assembly
PE00-CAPACITORS					
CD01	1	1	1	DF16103300	Film 0.01 μ F \pm 10%
CD03	1	1	1	EA10701090	Elect 100 μ F 10V
CE01	1	1	1	DD15330370	Ceramic 33pF \pm 5%
CE02	1	1	1	DD15330370	Ceramic 33pF \pm 5%
CE03	1	1	1	DF15152350	Film 0.0015 μ F \pm 5%
CE04	1	1	1	DF15152350	Film 0.0015 μ F \pm 5%
CE05	1	1	1	EA22701090	Elect 220 μ F 10V
CE06	1	1	1	EA22701090	Elect 220 μ F 10V
CE07	1	1	1	DF15152350	Film 0.0015 μ F \pm 5%
CE08	1	1	1	DF15152350	Film 0.0015 μ F \pm 5%
CE09	1	1	1	EA10601690	Elect 10 μ F 16V
CE10	1	1	1	EA10601690	Elect 10 μ F 16V

REF. DESIG.	Q'TY			PART NO.	DESCRIPTION
	U	C	N		
CE11	1	1	1	DD15360300	Ceramic 36pF \pm 5%
CE12	1	1	1	DD15360300	Ceramic 36pF \pm 5%
CE13	1	1	1	EQ10603510	Elect 10 μ F 35V
CE14	1	1	1	EQ10603510	Elect 10 μ F 35V
CE15	1	1	1	DD15330300	Ceramic 33pF \pm 5%
CE16	1	1	1	DD15330300	Ceramic 33pF \pm 5%
CE17	1	1	1	EA10703590	Elect 100 μ F 35V
CE18	1	1	1	EA10703590	Elect 100 μ F 35V
CE19	1	1	1	DF17474510	Film 0.47 μ F \pm 20%
CE20	1	1	1	DF17474510	Film 0.47 μ F \pm 20%
CE23	1	1	1	DF15152350	Film 0.0015 μ F \pm 5%
CE24	1	1	1	DF15152350	Film 0.0015 μ F \pm 5%
CE25	1	1	1	DF15152350	Film 0.0015 μ F \pm 5%
CE26	1	1	1	DF15152350	Film 0.0015 μ F \pm 5%
CE27	1	1	1	DD15360300	Ceramic 36pF \pm 5%
CE28	1	1	1	DD15360300	Ceramic 36pF \pm 5%
CE29	1	1	1	EA10601690	Elect 10 μ F 16V
CE30	1	1	1	EA10601690	Elect 10 μ F 16V
CE31	1	1	1	EQ10603510	Elect 10 μ F 35V
CE32	1	1	1	EQ10603510	Elect 10 μ F 35V
CE33	1	1	1	DD15330300	Ceramic 33pF \pm 5%
CE34	1	1	1	DD15330300	Ceramic 33pF \pm 5%
CH01	1	1	1	DF16104300	Film 0.1 μ F \pm 10%
CH02	1	1	1	DF16104300	Film 0.1 μ F \pm 10%
CH03	1	1	1	EA47503590	Elect 4.7 μ F 35V
CH04	1	1	1	EA47503590	Elect 4.7 μ F 35V
CH05	1	1	1	EA33603590	Elect 33 μ F 35V
CH06	1	1	1	EA33603590	Elect 33 μ F 35V
CH07	1	1	1	EA10703590	Elect 100 μ F 35V
CH08	1	1	1	EA10703590	Elect 100 μ F 35V
CH09	1	1	1	DF17474510	Film 0.47 μ F \pm 20%
CH10	1	1	1	DF17474510	Film 0.47 μ F \pm 20%
CH11	1	1	1	DF15224300	Film 0.22 μ F \pm 5%
CH12	1	1	1	DF15224300	Film 0.22 μ F \pm 5%
CH13	1	1	1	DF15224300	Film 0.22 μ F \pm 5%
CH14	1	1	1	DF15224300	Film 0.22 μ F \pm 5%
CH15	1	1	1	DF15224300	Film 0.22 μ F \pm 5%
CH16	1	1	1	DF15224300	Film 0.22 μ F \pm 5%
CH17	1	1	1	DF15152350	Film 0.0015 μ F \pm 5%
CH18	1	1	1	DF15152350	Film 0.0015 μ F \pm 5%
CH19	1	1	1	DF15222350	Film 0.0022 μ F \pm 5%
CH20	1	1	1	DF15222350	Film 0.0022 μ F \pm 5%
CH21	1	1	1	DF55391090	Film 390pF \pm 5%
CH22	1	1	1	DF55391090	Film 390pF \pm 5%
CH23	1	1	1	DF15683300	Film 0.068 μ F \pm 5%
CH24	1	1	1	DF15683300	Film 0.068 μ F \pm 5%
CH25	1	1	1	DF15683300	Film 0.068 μ F \pm 5%
CH26	1	1	1	DF15683300	Film 0.068 μ F \pm 5%
CH27	1	1	1	DF15182350	Film 0.0018 μ F \pm 5%
CH28	1	1	1	DF15182350	Film 0.0018 μ F \pm 5%

• (U): for U.S.A.
 • (C): for Canada
 • (N): for Europe

REF. DESIG.	Q'TY			PART NO.	DESCRIPTION
	U	C	N		
PE00-RESISTORS (All Resistors are ±5% and ¼W)					
RD01	1	1	1	GA05472010	4.7KΩ 1W
RD04	1	1	1	GD05103140	10KΩ
RD05	1	1	1	GD05304140	300KΩ
RD06	1	1	1	GD05104140	100KΩ
RD07	1	1	1	GD05753140	75KΩ
RD08	1	1	1	GD05103140	10KΩ
RD09	1	1	1	GD05153140	15KΩ
RD10	1	1	1	GD05182140	1.8KΩ
RD11	1	1	1	GD05101140	100Ω
RE01	1	1	1	GD05331140	330Ω
RE02	1	1	1	GD05331140	330Ω
RE03	1	1	1	GD05224140	220KΩ
RE04	1	1	1	GD05224140	220KΩ
RE05	1	1	1	GD05222140	2.2KΩ
RE06	1	1	1	GD05222140	2.2KΩ
RE07	1	1	1	GD05222140	2.2KΩ
RE08	1	1	1	GD05222140	2.2KΩ
RE09	1	1	1	GD05101140	100Ω
RE10	1	1	1	GD05101140	100Ω
RE11	1	1	1	GD05101140	100Ω
RE12	1	1	1	GD05101140	100Ω
RE13	1	1	1	GD05153140	15KΩ
RE14	1	1	1	GD05153140	15KΩ
RE15	1	1	1	GD05560140	56Ω
RE16	1	1	1	GD05560140	56Ω
RE17	1	1	1	GD05182140	1.8KΩ
RE18	1	1	1	GD05182140	1.8KΩ
RE19	1	1	1	GD05222140	2.2KΩ
RE20	1	1	1	GD05222140	2.2KΩ
RE21	1	1	1	GD05222140	2.2KΩ
RE22	1	1	1	GD05222140	2.2KΩ
RE23	1	1	1	GD05151140	150Ω
RE24	1	1	1	GD05151140	150Ω
RE25	1	1	1	GD05151140	150Ω
RE26	1	1	1	GD05151140	150Ω
RE27	1	1	1	GD05473140	47KΩ
RE28	1	1	1	GD05473140	47KΩ
RE29	1	1	1	GD05473140	47KΩ
RE30	1	1	1	GD05473140	47KΩ
RE31	1	1	1	GD05560140	56Ω
RE32	1	1	1	GD05560140	56Ω
RE33	1	1	1	GD05102140	1KΩ
RE34	1	1	1	GD05102140	1KΩ
RE35	1	1	1	GG05270140	27Ω
RE36	1	1	1	GG05270140	27Ω
RE37	1	1	1	GG05270140	27Ω
RE38	1	1	1	GG05270140	27Ω
RE39	1	1	1	GD05047140	4.7Ω
RE40	1	1	1	GD05047140	4.7Ω
RE41	1	1	1	GD05104140	100KΩ
RE42	1	1	1	GD05104140	100KΩ
RE43	1	1	1	GD05183140	18KΩ
RE44	1	1	1	GD05183140	18KΩ
RE45	1	1	1	GD05331140	330Ω
RE46	1	1	1	GD05331140	330Ω
RE49	1	1	1	GD05222140	2.2KΩ
RE50	1	1	1	GD05222140	2.2KΩ
RE51	1	1	1	GD05222140	2.2KΩ
RE52	1	1	1	GD05222140	2.2KΩ

REF. DESIG.	Q'TY			PART NO.	DESCRIPTION
	U	C	N		
RE53	1	1	1	GD05101140	100Ω
RE54	1	1	1	GD05101140	100Ω
RE55	1	1	1	GD05101140	100Ω
RE56	1	1	1	GD05101140	100Ω
RE57	1	1	1	GD05153140	15KΩ
RE58	1	1	1	GD05153140	15KΩ
RE59	1	1	1	GD05222140	2.2KΩ
RE60	1	1	1	GD05222140	2.2KΩ
RE61	1	1	1	GD05222140	2.2KΩ
RE62	1	1	1	GD05222140	2.2KΩ
RE63	1	1	1	GD05560140	56Ω
RE64	1	1	1	GD05560140	56Ω
RE65	1	1	1	GD05560140	56Ω
RE66	1	1	1	GD05560140	56Ω
RE67	1	1	1	GD05473140	47KΩ
RE68	1	1	1	GD05473140	47KΩ
RE69	1	1	1	GD05473140	47KΩ
RE70	1	1	1	GD05473140	47KΩ
RE71	1	1	1	GD05151140	150Ω
RE72	1	1	1	GD05151140	150Ω
RE73	1	1	1	GD05151140	150Ω
RE74	1	1	1	GD05151140	150Ω
RE75	1	1	1	GD05102140	1KΩ
RE76	1	1	1	GD05102140	1KΩ
RE77	1	1	1	GG05270140	27Ω
RE78	1	1	1	GG05270140	27Ω
RE79	1	1	1	GG05270140	27Ω
RE70	1	1	1	GG05270140	27Ω
RE83	1	1	1	GD05104140	100KΩ
RE84	1	1	1	GD05104140	100KΩ
RE85	1	1	1	GD05105140	1MΩ
RE86	1	1	1	GD05105140	1MΩ
RE87	1	1	1	GA05680010	68Ω 1W
RE88	1	1	1	GA05680010	68Ω 1W
RH01	1	1	1	GD05331140	330Ω
RH02	1	1	1	GD05331140	330Ω
RH03	1	1	1	GD05471140	470Ω
RH04	1	1	1	GD05471140	470Ω
RH05	1	1	1	GD05471140	470Ω
RH06	1	1	1	GD05471140	470Ω
RH07	1	1	1	GD05332140	3.3KΩ
RH08	1	1	1	GD05332140	3.3KΩ
RH09	1	1	1	GD05332140	3.3KΩ
RH10	1	1	1	GD05332140	3.3KΩ
RH11	1	1	1	GD05104140	100KΩ
RH12	1	1	1	GD05104140	100KΩ
RH13	1	1	1	GD05101140	100Ω
RH14	1	1	1	GD05101140	100Ω
RH15	1	1	1	GD05101140	100Ω
RH16	1	1	1	GD05101140	100Ω
RH17	1	1	1	GG05047140	4.7Ω
RH18	1	1	1	GG05047140	4.7Ω
RH19	1	1	1	GG05047140	4.7Ω
RH20	1	1	1	GG05047140	4.7Ω

- (U): for U.S.A.
- (C): for Canada
- (N): for Europe

REF. DESIG.	Q'TY			PART NO.	DESCRIPTION
	U	C	N		
RH21	1	1	1	GD05105140	1M Ω
RH22	1	1	1	GD05105140	1M Ω
RH23	1	1	1	GD05104140	100K Ω
RH24	1	1	1	GD05104140	100K Ω
RH25	1	1	1	GA05680010	68 Ω 1W
RH26	1	1	1	GA05680010	68 Ω 1W
RH27	1	1	1	GD05393140	39K Ω
RH28	1	1	1	GD05393140	39K Ω
RH29	1	1	1	GD05153140	15K Ω
RH30	1	1	1	GD05153140	15K Ω
RH31	1	1	1	GD05304140	300K Ω
RH32	1	1	1	GD05304140	300K Ω
RH33	1	1	1	GD05113140	11K Ω
RH34	1	1	1	GD05113140	11K Ω
RH35	1	1	1	GD05113140	11K Ω
RH36	1	1	1	GD05113140	11K Ω
RH37	1	1	1	GD05113140	11K Ω
RH38	1	1	1	GD05113140	11K Ω
RH39	1	1	1	GD05182140	1.8K Ω
RH40	1	1	1	GD05182140	1.8K Ω
RH41	1	1	1	GD05153140	15K Ω
RH42	1	1	1	GD05153140	15K Ω
RH43	1	1	1	GD05224140	220K Ω
RH44	1	1	1	GD05224140	220K Ω
RH45	1	1	1	GD05101140	100 Ω
RH46	1	1	1	GD05101140	100 Ω
RH47	1	1	1	GD05150140	15 Ω
RH48	1	1	1	GD05150140	15 Ω
RH49	1	1	1	GD05150140	15 Ω
RH50	1	1	1	GD05150140	15 Ω
PE00-SEMICONDUCTORS					
QD01	1	1	1	HT110152A0	Transistor 2SA1015 (O or Y)
QD02	1	1	1	HT318152A0	Transistor 2SC1815 (O or Y)
QD03	1	1	1	HT318152A0	Transistor 2SC1815 (O or Y)
QD05	1	1	1	HD20003210	Diode 1S2471
QD06	1	1	1	HD20003210	Diode 1S2471
QE01	1	1	1	HF201172B0	F.E.T. 2SK117 (Y or GR)
QE02	1	1	1	HF201172B0	F.E.T. 2SK117 (Y or GR)
QE03	1	1	1	HF201172B0	F.E.T. 2SK117 (Y or GR)
QE04	1	1	1	HF201172B0	F.E.T. 2SK117 (Y or GR)
QE05	1	1	1	HT108722D0	Transistor 2SA872A (D or E)
QE06	1	1	1	HT108722D0	Transistor 2SA872A (D or E)
QE07	1	1	1	HT108722D0	Transistor 2SA872A (D or E)
QE08	1	1	1	HT108722D0	Transistor 2SA872A (D or E)
QE09	1	1	1	HT317752D0	Transistor 2SC1775A (D or E)
QE10	1	1	1	HT317752D0	Transistor 2SC1775A (D or E)
QE11	1	1	1	HT406661C0	Transistor 2SA666 (C)
QE12	1	1	1	HT406661C0	Transistor 2SA666 (C)
QE13	1	1	1	HT206461C0	Transistor 2SB646 (C)
QE14	1	1	1	HT206461C0	Transistor 2SB646 (C)
QE15	1	1	1	HF201172B0	F.E.T. 2SK117 (Y or GR)
QE16	1	1	1	HF201172B0	F.E.T. 2SK117 (Y or GR)
QE17	1	1	1	HF201172B0	F.E.T. 2SK117 (Y or GR)
QE18	1	1	1	HF201172B0	F.E.T. 2SK117 (Y or GR)
QE19	1	1	1	HT108722D0	Transistor 2SA872A (D or E)
QE20	1	1	1	HT108722D0	Transistor 2SA872A (D or E)

REF. DESIG.	Q'TY			PART NO.	DESCRIPTION
	U	C	N		
QE21	1	1	1	HT108722D0	Transistor 2SA872A (D or E)
QE22	1	1	1	HT108722D0	Transistor 2SA872A (D or E)
QE23	1	1	1	HT317752D0	Transistor 2SC1775A (D or E)
QE24	1	1	1	HT317752D0	Transistor 2SC1775A (D or E)
QE25	1	1	1	HT406661C0	Transistor 2SD666 (C)
QE26	1	1	1	HT406661C0	Transistor 2SD666 (C)
QE27	1	1	1	HT206461C0	Transistor 2SB646 (C)
QE28	1	1	1	HT206461C0	Transistor 2SB646 (C)
QE29	1	1	1	HD20003210	Diode 1S2471
QE30	1	1	1	HD20003210	Diode 1S2471
QE31	1	1	1	HV00006120	Varistor MV203 (Y)
QE32	1	1	1	HV00006120	Varistor MV203 (Y)
QE33	1	1	1	HD20003210	Diode 1S2471
QE34	1	1	1	HD20003210	Diode 1S2471
QE35	1	1	1	HV00006120	Varistor MV203 (Y)
QE36	1	1	1	HV00006120	Varistor MV203 (Y)
QH01	1	1	1	HT108722D0	Transistor 2SA872 (D or E)
QH02	1	1	1	HT108722D0	Transistor 2SA872 (D or E)
QH03	1	1	1	HT317752D0	Transistor 2SC1775 (D or E)
QH04	1	1	1	HT317752D0	Transistor 2SC1775 (D or E)
QH05	1	1	1	HT322401A0	Transistor 2SC2240 (GR)
QH06	1	1	1	HT322401A0	Transistor 2SC2240 (GR)
QH07	1	1	1	HT109701A0	Transistor 2SA970 (GR)
QH08	1	1	1	HT109701A0	Transistor 2SA970 (GR)
QH09	1	1	1	HT406661C0	Transistor 2SD666 (C)
QH10	1	1	1	HT406661C0	Transistor 2SD666 (C)
QH11	1	1	1	HT206461C0	Transistor 2SB646 (C)
QH12	1	1	1	HT206461C0	Transistor 2SB646 (C)
PE00-MISCELLANEOUS					
LD01	1	1	1	LY20240120	Relay
JH01	1	1	1	YP06001160	Plug, (12P)
JH02	1	1	1	YP06001140	Plug, (7P)
JH03	1	1	1	YP06001140	Plug, (7P)
SH01	1	1	1	SP04060090	Push Switch
PF00-TONE VR. CIRCUIT BOARD					
PF00	2	2	2	YN29782240	P.W. Board, Tone VR.
	2	2	2	ZZ29782240	P.W. Board Assembly
PF00-CAPACITORS					
CF01	2	2	2	DF15153300	Film 0.015 μ F \pm 5%
CF02	2	2	2	DF15153300	Film 0.015 μ F \pm 5%
CF03	2	2	2	DF15562300	Film 0.0056 μ F \pm 5%
CF04	2	2	2	DD15331370	Ceramic 330pF \pm 5%
CF05	2	2	2	DF15562300	Film 0.0056 μ F \pm 5%
CF06	2	2	2	DF15103300	Film 0.01 μ F \pm 5%
CF07	2	2	2	DF15103300	Film 0.01 μ F \pm 5%
CF08	2	2	2	DD15221370	Ceramic 220pF \pm 5%

• (U): for U.S.A.
 • (C): for Canada
 • (N): for Europe

REF. DESIG.	Q'TY			PART NO.	DESCRIPTION
	U	C	N		
PF00-RESISTORS (All Resistors are ±5% and ¼W)					
RF01	2	2	2	RX01040040	Variable, Bass
RF02	2	2	2	RX01040040	Variable, Mid
RF03	2	2	2	RX01040040	Variable, Treble
RF04	2	2	2	GD05183140	18KΩ
RF05	2	2	2	GD05183140	18KΩ
RF06	2	2	2	GD05273140	27KΩ
RF07	2	2	2	GD05273140	27KΩ
RF08	2	2	2	GD05562140	5.6KΩ
RF09	2	2	2	GD05562140	5.6KΩ
RF11	2	2	2	GD05392140	3.9KΩ
RF12	2	2	2	GD05562140	5.6KΩ
RF13	2	2	2	GD05562140	5.6KΩ
PF00-JACK					
JF01	2	2	2	YJ06001970	Jack, (10P)
JF02	2	2	2	YJ06001980	Jack, (6P)
PF01-TONE VR CONNECTOR CIRCUIT BOARD					
PF01	2	2	2	YN29782220	P.W. Board, Tone VR Connector
	2	2	2	ZZ29782220	P.W. Board Assembly
JF03	2	2	2	YP06001670	Plug, (16P)
PG00-VOLUME BUFFER CIRCUIT BOARD					
PG00	1	1	1	YN29782230	P.W. Board, Volume Buffer
	1	1	1	ZZ29781100	P.W. Board Assembly
PG00-CAPACITORS					
CG01	1	1	1	DF16104300	Film 0.1μF ±10%
CG02	1	1	1	DF16104300	Film 0.1μF ±10%
CG05	1	1	1	EA33603590	Elect 33μF 35V
CG06	1	1	1	EA33603590	Elect. 33μF 35V
PG00-RESISTORS (All Resistors are ±5% and ¼W)					
RG01	1	1	1	RG05030070	Variable 50KΩ x 4
RG03	1	1	1	GD05471140	470Ω
RG04	1	1	1	GD05471140	470Ω
RG05	1	1	1	GD05471140	470Ω
RG06	1	1	1	GD05471140	470Ω
RG07	1	1	1	GD05332140	3.3KΩ
RG08	1	1	1	GD05332140	3.3KΩ
RG09	1	1	1	GD05332140	3.3KΩ
RG10	1	1	1	GD05332140	3.3KΩ
RG11	1	1	1	GD05104140	100KΩ
RG12	1	1	1	GD05104140	100KΩ
RG13	1	1	1	GD05101140	100Ω
RG14	1	1	1	GD05101140	100Ω
RG15	1	1	1	GD05101140	100Ω
RG16	1	1	1	GD05101140	100Ω
RG17	1	1	1	GG05047140	4.7Ω
RG18	1	1	1	GG05047140	4.7Ω
RG19	1	1	1	GG05047140	4.7Ω
RG20	1	1	1	GG05047140	4.7Ω
RG21	1	1	1	GD05224140	220KΩ

REF. DESIG.	Q'TY			PART NO.	DESCRIPTION
	U	C	N		
RG22	1	1	1	GD05224140	220KΩ
RG23	1	1	1	GD05224140	220KΩ
RG24	1	1	1	GD05224140	220KΩ
RG25	1	1	1	GD05331140	330Ω
RG26	1	1	1	GD05331140	330Ω
RG27	1	1	1	GD05102140	1KΩ
RG28	1	1	1	GD05102140	1KΩ
RG29	1	1	1	GD05150140	15Ω
RG30	1	1	1	GD05150140	15Ω
RG31	1	1	1	GD05150140	15Ω
RG32	1	1	1	GD05150140	15Ω
PG00-SEMICONDUCTORS					
QG01	1	1	1	HT108722D0	Transistor 2SA872A (D or E)
QG02	1	1	1	HT108722D0	Transistor 2SA872A (D or E)
QG03	1	1	1	HT317752D0	Transistor 2SC1775A (D or E)
QG04	1	1	1	HT317752D0	Transistor 2SC1775A (D or E)
QG05	1	1	1	HT322401A0	Transistor 2SC2240 (GR)
QG06	1	1	1	HT322401A0	Transistor 2SC2240 (GR)
QG07	1	1	1	HT109701A0	Transistor 2SA970 (GR)
QG08	1	1	1	HT109701A0	Transistor 2SA970 (GR)
QG09	1	1	1	HT406661C0	Transistor 2SD666 (C)
QG10	1	1	1	HT406661C0	Transistor 2SD666 (C)
QG11	1	1	1	HT206461C0	Transistor 2SB646 (C)
QG12	1	1	1	HT206461C0	Transistor 2SB646 (C)
PG00-MISCELLANEOUS					
JG01	1	1	1	YJ06001660	Jack, (7P)
JG02	1	1	1	YJ06001660	Jack, (7P)
SG01	1	1	1	SR04050180	Rotary Switch
PJ00-SELECTOR SWITCH CIRCUIT BOARD					
PJ00	1	1	1	YF29780030	P.W. Board, Selector Switch
	1	1	1	ZZ29780030	P.W. Board Assembly
CJ01	1	1	1	EA47503590	Elect Cap. 4.7μF 35V
PJ00-MISCELLANEOUS					
JJ01	1	1	1	YJ06001970	Jack, (10P)
JJ02	1	1	1	YJ06001980	Jack, (6P)
JJ03	1	1	1	YJ06001680	Jack, (12P)
SJ01	1	1	1	SP06060100	Push Switch, Input
SJ02	1	1	1	SR04050170	Rotary Switch, Record, 1
SJ03	1	1	1	SR04050170	Rotary Switch, Record, 2
PK00-TAPE EQ CIRCUIT BOARD					
PK00	1	1	1	YF29780040	P.W. Board, Tape EQ
	1	1	1	ZZ29780040	P.W. Board Assembly
PK00-CAPACITORS					
CK01	1	1	1	DF16104300	Film 0.1μF ±10%
CK02	1	1	1	DF16104300	Film 0.1μF ±10%
CK03	1	1	1	EA10603590	Elect 10μF 35V
CK04	1	1	1	EA10603590	Elect 10μF 35V
CK05	1	1	1	EA10605090	Elect 10μF 50V
CK06	1	1	1	EA10605090	Elect 10μF 50V
CK08	1	1	1	EA10703590	Elect 100μF 35V
CK09	1	1	1	EA10703590	Elect 100μF 35V
CK11	1	1	1	DF16222300	Film 0.0022μF ±10%
CK12	1	1	1	DF16222300	Film 0.0022μF ±10%

- (U): for U.S.A.
- (C): for Canada
- (N): for Europe

REF. DESIG.	Q'TY			PART NO.	DESCRIPTION
	U	C	N		
PK00-RESISTORS (All Resistors are ±5% and ¼W)					
RK01	1	1	1	GD05331140	330Ω
RK02	1	1	1	GD05331140	330Ω
RK03	1	1	1	GD05471140	470Ω
RK04	1	1	1	GD05471140	470Ω
RK05	1	1	1	GD05471140	470Ω
RK06	1	1	1	GD05471140	470Ω
RK07	1	1	1	GD05332140	3.3KΩ
RK08	1	1	1	GD05332140	3.3KΩ
RK09	1	1	1	GD05332140	3.3KΩ
RK10	1	1	1	GD05332140	3.3KΩ
RK11	1	1	1	GD05104140	100KΩ
RK12	1	1	1	GD05104140	100KΩ
RK13	1	1	1	GD05101140	100Ω
RK14	1	1	1	GD05101140	100Ω
RK15	1	1	1	GD05101140	100Ω
RK16	1	1	1	GD05101140	100Ω
RK17	1	1	1	GD05047140	4.7Ω
RK18	1	1	1	GD05047140	4.7Ω
RK19	1	1	1	GD05047140	4.7Ω
RK20	1	1	1	GD05047140	4.7Ω
RK21	1	1	1	GD05047140	4.7Ω
RK22	1	1	1	GD05047140	4.7Ω
RK23	1	1	1	GD05104140	100KΩ
RK24	1	1	1	GD05104140	100KΩ
RK25	1	1	1	GF05151120	150Ω ¼W
RK26	1	1	1	GF05151120	150Ω ¼W
RK27	1	1	1	GD05224140	220KΩ
RK28	1	1	1	GD05224140	220KΩ
RK29	1	1	1	GD05150140	15Ω
RK30	1	1	1	GD05150140	15Ω
RK31	1	1	1	GD05150140	15Ω
RK32	1	1	1	GD05150140	15Ω
PK00-SEMICONDUCTORS					
QK01	1	1	1	HT108722D0	Transistor 2SA872A (D or E)
QK02	1	1	1	HT108722D0	Transistor 2SA872A (D or E)
QK03	1	1	1	HT317752D0	Transistor 2SC1775A (D or E)
QK04	1	1	1	HT317752D0	Transistor 2SC1775A (D or E)
QK05	1	1	1	HT322401A0	Transistor 2SC2240 (GR)
QK06	1	1	1	HT322401A0	Transistor 2SC2240 (GR)
QK07	1	1	1	HT109701A0	Transistor 2SA970 (GR)
QK08	1	1	1	HT109701A0	Transistor 2SA970 (GR)
QK09	1	1	1	HT406661C0	Transistor 2SD666 (C)
QK10	1	1	1	HT406661C0	Transistor 2SD666 (C)
QK11	1	1	1	HT206461C0	Transistor 2SB646 (C)
QK12	1	1	1	HT206461C0	Transistor 2SB646 (C)
PK00-MISCELLANEOUS					
JK01	1	1	1	YP06001580	Plug, (12P)
JK02	1	1	1	YJ06001680	Jack, (12P)
SK01	1	1	1	SC00030010	Switch
SK02	1	1	1	SB11000010	Switch Band, Flx
SK03	1	1	1	SS10040010	Slide Switch

REF. DESIG.	Q'TY			PART NO.	DESCRIPTION
	U	C	N		
PL00-CARTRIDGE LOAD CIRCUIT BOARD P.W. Board, Cartridge Load P.W. Board Assembly					
PL00	1	1	1	YH29781210	
	1	1	1	ZZ29781210	
PL00-CAPACITORS					
CL01	1	1	1	DD15390300	Ceramic 39pF ±5%
CL02	1	1	1	DD15390300	Ceramic 39pF ±5%
CL03	1	1	1	DF55101090	Film 100pF ±5%
CL04	1	1	1	DF55101090	Film 100pF ±5%
CL05	1	1	1	DF55221090	Film 220pF ±5%
CL06	1	1	1	DF55221090	Film 220pF ±5%
CL07	1	1	1	DF55361090	Film 360pF ±5%
CL08	1	1	1	DF55361090	Film 360pF ±5%
CL09	1	1	1	DD15390300	Ceramic 39pF ±5%
CL10	1	1	1	DD15390300	Ceramic 39pF ±5%
CL11	1	1	1	DF55101090	Film 100pF ±5%
CL12	1	1	1	DF55101090	Film 100pF ±5%
CL13	1	1	1	DF55221090	Film 220pF ±5%
CL14	1	1	1	DF55221090	Film 220pF ±5%
CL15	1	1	1	DF55361090	Film 360pF ±5%
CL16	1	1	1	DF55361090	Film 360pF ±5%
CL17	1	1	1	DD15100010	Ceramic 10pF ±5%
CL18	1	1	1	DD15100010	Ceramic 10pF ±5%
PL00-RESISTORS (All Resistors are ±5% and ¼W)					
RL01	1	1	1	GD05112140	1.1KΩ
RL02	1	1	1	GD05112140	1.1KΩ
RL03	1	1	1	GD05123140	12KΩ
RL04	1	1	1	GD05123140	12KΩ
RL05	1	1	1	GD05393140	39KΩ
RL06	1	1	1	GD05393140	39KΩ
RL07	1	1	1	GD05104140	100KΩ
RL08	1	1	1	GD05104140	100KΩ
RL09	1	1	1	GD05112140	1.1KΩ
RL10	1	1	1	GD05112140	1.1KΩ
RL11	1	1	1	GD05123140	12KΩ
RL12	1	1	1	GD05123140	12KΩ
RL13	1	1	1	GD05393140	39KΩ
RL14	1	1	1	GD05393140	39KΩ
RL15	1	1	1	GD05104140	100KΩ
RL16	1	1	1	GD05104140	100KΩ
PL00-SWITCH					
SL01	1	1	1	SR04050190	Rotary Switch
SL02	1	1	1	SR04050190	Rotary Switch

• (U): for U.S.A.
 • (C): for Canada
 • (N): for Europe

REF. DESIG.	Q'TY			PART NO.	DESCRIPTION
	U	C	N		
PM01	1	1	1	YK29780210	PM01-MC AMP. CIRCUIT BOARD P.W. Board, MC Amp. P.W. Board Assembly
	1	1	1	ZZ29780210	
PM01-CAPACITORS					
CM01	1	1	1	DD15101300	Ceramic 100pF ±5%
CM02	1	1	1	DD15101300	Ceramic 100pF ±5%
CM03	1	1	1	DF15152350	Film 0.0015μF ±5%
CM04	1	1	1	DF15152350	Film 0.0015μF ±5%
CM05	1	1	1	EA47700690	Elect 470μF 6V
CM06	1	1	1	EA47700690	Elect 470μF 6V
CM07	1	1	1	EA47503590	Elect 4.7μF 35V
CM08	1	1	1	EA47503590	Elect 4.7μF 35V
CM09	1	1	1	DD15560300	Ceramic 56pF ±5%
CM10	1	1	1	DD15560300	Ceramic 56pF ±5%
CM11	1	1	1	EA47700690	Elect 470μF 6.3V
CM12	1	1	1	EA47700690	Elect 470μF 6.3V
CM13	1	1	1	DF15102300	Film 0.001μF ±5%
CM14	1	1	1	DF15102300	Film 0.001μF ±5%
CM15	1	1	1	EQ10603510	Elect 10μF 35V
CM16	1	1	1	EQ10603510	Elect 10μF 35V
CM17	1	1	1	DF17474510	Film 0.47μF ±20%
CM18	1	1	1	DF17474510	Film 0.47μF ±20%
CM19	1	1	1	EA47601690	Elect 47μF 16V
CM20	1	1	1	EA47601690	Elect 47μF 16V
CM21	1	1	1	EA22701690	Elect 220μF 16V
CM22	1	1	1	EA22701690	Elect 220μF 16V
PM01-RESISTORS (All Resistors are ±5% and ¼W)					
RM01	1	1	1	GD05033140	3.3Ω
RM02	1	1	1	GD05033140	3.3Ω
RM03	1	1	1	GD05470140	47Ω
RM04	1	1	1	GD05470140	47Ω
RM05	1	1	1	GM21422110	2.21KΩ ±2%
RM06	1	1	1	GM21422110	2.21KΩ ±2%
RM07	1	1	1	GD05163140	16KΩ
RM08	1	1	1	GD05163140	16KΩ
RM09	1	1	1	GD05220140	22Ω
RM10	1	1	1	GD05220140	22Ω
RM11	1	1	1	GD05152140	1.5KΩ
RM12	1	1	1	GD05152140	1.5KΩ
RM13	1	1	1	GD05121140	120Ω
RM14	1	1	1	GD05121140	120Ω
RM15	1	1	1	GD05153140	15KΩ
RM16	1	1	1	GD05153140	15KΩ
RM17	1	1	1	GD05152140	1.5KΩ
RM18	1	1	1	GD05152140	1.5KΩ
RM19	1	1	1	GG05220140	22Ω
RM20	1	1	1	GG05220140	22Ω

REF. DESIG.	Q'TY			PART NO.	DESCRIPTION
	U	C	N		
RM21	1	1	1	GG05220140	22Ω
RM22	1	1	1	GG05220140	22Ω
RM23	1	1	1	GD05471140	470Ω
RM24	1	1	1	GD05471140	470Ω
RM25	1	1	1	GD05103140	10KΩ
RM26	1	1	1	GD05103140	10KΩ
RM27	1	1	1	GD05470140	47Ω
RM28	1	1	1	GD05470140	47Ω
RM29	1	1	1	GD05470140	47Ω
RM30	1	1	1	GD05470140	47Ω
RM31	1	1	1	GD05223140	22KΩ
RM32	1	1	1	GD05223140	22KΩ
RM33	1	1	1	GD05273140	27KΩ
RM34	1	1	1	GD05273140	27KΩ
PM01-SEMICONDUCTORS					
QM01	1	1	1	HF201472A0	F.E.T. 2SK147 (GR-BL)
QM02	1	1	1	HF201472A0	F.E.T. 2SK147 (GR-BL)
QM03	1	1	1	HT109701A0	Transistor 2SA970 (GR)
QM04	1	1	1	HT109701A0	Transistor 2SA970 (GR)
QM05	1	1	1	HT406661C0	Transistor 2SD666 (C)
QM06	1	1	1	HT406661C0	Transistor 2SD666 (C)
QM07	1	1	1	HT206461C0	Transistor 2SB646 (C)
QM08	1	1	1	HT206461C0	Transistor 2SB646 (C)
QM09	1	1	1	HV00006120	Varistor MV203 (Y)
QM10	1	1	1	HV00006120	Varistor MV203 (Y)
QM11	1	1	1	HT403132P0	Transistor 2SD313 (D or E)
QM12	1	1	1	HT205072P0	Transistor 2SB507 (D or E)
SM01	1	1	1	SP04010300	PM01-SWITCH Push Switch
PN00-PEAK IND. CIRCUIT BOARD					
PN00	1	1	1	YG29560022	P.W. Board, Peak Ind.
				ZZ29902020	P.W. Board Assembly
PN00-CAPACITORS					
CN01	1	1	1	EA33505090	Elect 3.3μF 50V
CN02	1	1	1	EA33505090	Elect 3.3μF 50V
CN04	1	1	1	EA10706390	Elect 100μF 63V
CN05	1	1	1	EA22701690	Elect 220μF 16V
CN06	1	1	1	EA47601690	Elect 47μF 16V
CN07	1	1	1	EA47601690	Elect 47μF 16V
PN00-RESISTORS (All Resistors are ±5% and ¼W)					
RN15	1	1	1	RT05103140	10KΩ
RN16	1	1	1	RT05103140	10KΩ
RN17	1	1	1	RT05393140	39KΩ
RN18	1	1	1	RT05393140	39KΩ
RN19	1	1	1	RT05183140	18KΩ
RN20	1	1	1	RT05183140	18KΩ
RN21	1	1	1	RT05302140	3KΩ
RN22	1	1	1	RT05302140	3KΩ
RN23	1	1	1	RT05753140	75KΩ
RN24	1	1	1	RT05753140	75KΩ
RN25	1	1	1	RT05753140	75KΩ
RN26	1	1	1	RT05753140	75KΩ
RN27	1	1	1	RT05473140	47KΩ
RN28	1	1	1	RT05473140	47KΩ
RN29	1	1	1	RT05473140	47KΩ

- (U): for U.S.A.
- (C): for Canada
- (N): for Europe

REF. DESIG.	Q'TY			PART NO.	DESCRIPTION
	U	C	N		
RN30	1	1	1	RT05473140	47K Ω
RN31	1	1	1	RT05183140	18K Ω
RN32	1	1	1	RT05183140	18K Ω
RN33	1	1	1	RT05333140	33K Ω
RN34	1	1	1	RT05333140	33K Ω
RN35	1	1	1	RT05223140	22K Ω
RN36	1	1	1	RT05223140	22K Ω
RN37	1	1	1	RT05104140	100K Ω
RN38	1	1	1	RT05104140	100K Ω
RN39	1	1	1	RT05823140	82K Ω
RN40	1	1	1	RT05823140	82K Ω
RN41	1	1	1	RT05512140	5.1K Ω
RN42	1	1	1	RT05512140	5.1K Ω
RN43	1	1	1	RT05273140	27K Ω
RN44	1	1	1	RT05273140	27K Ω
RN45	1	1	1	RT05363140	36K Ω
RN46	1	1	1	GA05391010	390 Ω 1W
RN47	1	1	1	RT05274140	270K Ω
RN48	1	1	1	GD05393140	39K Ω
RN49	1	1	1	RT05273140	27K Ω
RN50	1	1	1	RT05682140	6.8K Ω
RN51	1	1	1	RT05224140	220K Ω
RN52	1	1	1	RT05562140	5.6K Ω
RN53	1	1	1	RT05562140	5.6K Ω
RN54	1	1	1	GA05332010	3.3K Ω 1W
RN55	1	1	1	RT05511140	510 Ω
RN56	1	1	1	RT05511140	510 Ω
PN00-SEMICONDUCTORS					
QN03	1	1	1	HT309452A0	Transistor 2SC945 (Q or R)
QN04	1	1	1	HT309452A0	Transistor 2SC945 (Q or R)
QN05	1	1	1	HT309452A0	Transistor 2SC945 (Q or R)
QN06	1	1	1	HT309452A0	Transistor 2SC945 (Q or R)
QN09	1	1	1	HT309452A0	Transistor 2SC945 (Q or R)
QN10	1	1	1	HT313182B0	Transistor 2SC1318 (R or S)
QN11	1	1	1	HT313182B0	Transistor 2SC1318 (R or S)
QN13	1	1	1	HD30023090	Zener WZ-071
QN14	1	1	1	HD20011030	Diode DS131B
QN15	1	1	1	HT108722D0	Transistor 2SA872A (D or E)
QN16	1	1	1	HT108722D0	Transistor 2SA872A (D or E)
QN17	1	1	1	HT108722D0	Transistor 2SA872A (D or E)
QN18	1	1	1	HT108722D0	Transistor 2SA872A (D or E)
QN19	1	1	1	HT317752E0	Transistor 2SC1775A (E or F)
QN20	1	1	1	HT317752E0	Transistor 2SC1775A (E or F)
QN23	1	1	1	HD20001210	Diode 1S2473
QN24	1	1	1	HD20001210	Diode 1S2473
QN25	1	1	1	HD20001210	Diode 1S2473
QN26	1	1	1	HD20001210	Diode 1S2473
QN27	1	1	1	HD20011010	Diode W06C
QN28	1	1	1	HD20011010	Diode W06C
QN29	1	1	1	HD20005010	Diode W06B
QN30	1	1	1	HD20005010	Diode W06B
PN00-MISCELLANEOUS					
JN01	1	1	1	YP06001070	Plug, (9P)
JN02	1	1	1	YP06001070	Plug, (9P)
JN03	1	1	1	YP06001040	Plug, (3P)
JN04	1	1	1	YP06001060	Plug, (7P)
LN01	1	1	1	LY20240110	Relay

REF. DESIG.	Q'TY			PART NO.	DESCRIPTION
	U	C	N		
PV00-RCA PIN CIRCUIT BOARD					
PV00	1	1	1	YF29780020	P.W. Board, RCA Pin
	1	1		ZZ29901020	P.W. Board Assembly
			1	ZZ29908020	P.W. Board Assembly
CV01	1	1	1	DK18473320	Ceramic 0.047 μ F +100% -0
PV00-RESISTORS (All Resistors are \pm5% and $\frac{1}{4}$W)					
RV01			1	GD05394140	390K Ω
RV02			1	GD05394140	390K Ω
RV03			1	GD05104140	100K Ω
RV04			1	GD05104140	100K Ω
RV05			1	GD05394140	390K Ω
RV06			1	GD05394140	390K Ω
RV07			1	GD05104140	100K Ω
RV08			1	GD05104140	100K Ω
PV00-JACK					
JV01	1	1	1	YT02040270	Terminal, Phono 1, 2
JV02	1	1	1	YT02040150	Terminal, Tuner/Aux
JV03			1	BY01050060	Jack, Tape Monitor 1
JV03	1	1		YT02040150	Terminal, Tape Monitor 1
JV04			1	BY01050060	Jack, Tape Monitor 2
JV04	1	1		YT02040150	Terminal, Tape Monitor 2
JV05	1	1	1	YT02020150	Terminal, Scope Out
JV06			1	YT02040150	Terminal, Pre Out
JV06	1	1		YT02040210	Terminal, Pre Out
PW00-SPEAKER SWITCH CIRCUIT BOARD					
PW00	1	1	1	YD29700032	P.W. Board, Speaker Switch
	1	1	1	ZZ29780010	P.W. Board Assembly
PW00-RESISTORS					
RW01	1	1	1	GA05331020	330 Ω 2W
RW02	1	1	1	GA05331020	330 Ω 2W
RW03	1	1	1	GA05151010	150 Ω 1W
RW04	1	1	1	GA05151010	150 Ω 1W
PW00-MISCELLANEOUS					
JW01	1	1	1	YJ01000860	Jack, Headphone
SW01	1	1	1	SP02020240	Push Switch

(W01-99)	Assembly and Wiring
(T01-99)	Adjustment
(X01-00)	Correction

9. TECHNICAL SPECIFICATIONS

FOR U.S.A. MODEL ONLY

AMPLIFIER SECTION

RATED POWER OUTPUT, MINIMUM CONTINUOUS

AVERAGE POWER PER CHANNELS, BOTH CHANNELS DRIVEN	150 WATTS
POWER BAND	20 Hz to 20 kHz
TOTAL HARMONIC DISTORTION	0.03%
LOAD IMPEDANCE	8 OHMS

RATED POWER OUTPUT, MINIMUM CONTINUOUS

AVERAGE POWER PER CHANNELS, BOTH CHANNELS DRIVEN	190 WATTS
POWER BAND	20 Hz to 20 kHz
TOTAL HARMONIC DISTORTION	0.05%
LOAD IMPEDANCE	4 OHMS

I.M. Distortion (IHF method, 60 Hz and 7 kHz mixed 4 : 1 at rated power output)

at 8 ohm load impedance	0.03%
at 4 ohm load impedance	0.05%
Damping Factor (at 20 Hz)	65
Sensitivity (at MAIN IN)	1.5 V
Impedance (at MAIN IN)	80 k ohms
Frequency Response for Power Amp Only (at 1 watt output ± 1 dB)	DC-100 kHz
S/N Ratio (MAIN IN, "A" Weighted)	110 dB

PREAMPLIFIER SECTION

Phono Section

Input Overload at 1 kHz (MM)	250 mV
THD (150 mV Input at 1 kHz)	0.005%
Equivalent Input Noise ("A" Weighted)	
Phono (MM)	0.24 μV
Phono (MC)	0.09 μV
Dynamic Range ("A" Weighted)	
Phono (MM)	120 dB
Input Sensitivity (ref. to rated output)	
Phono (MM)	2.0 mV
Phono (MC)	200 μV
Input Impedance	
Phono (MM)	100 k, 47 k, 27 k, 10 k, or 1 k ohms
Phono (MC)	50 ohms
Input Capacitance (MM)	470, 330, 220, 150, or 100 pF
Frequency Response, RIAA 20 Hz to 20 kHz	± 0.2 dB
Signal to Noise Ratio (ref. to rated output and 7.75 mV input "PHONO MM" or 0.775 mV input "PHONO MC" at 1 kHz, "A" weighted)	
Phono (MM)	90 dB
Phono (MC)	80 dB
High Level Inputs (Aux Tape, and Tuner)	
Input Sensitivity (ref. rated output)	150 mV
Input Impedance	40 k ohms
Frequency Response	
20 Hz ~ 20 kHz	± 0.1 dB
5 Hz ~ 100 kHz	± 1.3 dB
Signal-to-Noise Ratio (ref. to Rated Output and 7.75 mV input "A" weighted)	100 dB
Output Levels	
Tape Out (ref. to 7.75 mV at Phono (MM) Input)	590 mV
Pre Out (ref. to 150 mV at Aux Inputs)	1.5 V
(ref. to 500 mV at Aux Inputs)	5.0 V
Output Impedance	
Tape Out (Phono Mode)	110 ohms
Pre Out	100 ohms

GENERAL

Power Requirements	120 V AC 60 Hz
Power Consumption at rated output, both channels operating (8 ohm load)	580 W
Idling power (volume control at zero)	90 W
Dimensions	
Panel Width	16-3/8" (416 mm)
Panel Height	5-3/4" (146 mm)
Depth	17-3/16" (436 mm)
Weight	
Unit alone	53.9 lbs (24.5 kg)
Packed for shipment	58.3 lbs (26.5 kg)

FOR EUROPEAN MODEL ONLY

AUDIO SECTION

POWER OUTPUT, DIN, 4 OHM, PER CHANNEL	230 W
POWER OUTPUT, FTC AMERICAN STANDARDS, 4 OHM, PER CHANNEL	190 W
TOTAL HARMONIC DISTORTION AT RATED POWER OUTPUT	0.03%
I.M. DISTORTION AT RATED POWER OUTPUT	
(250 Hz AND 8 kHz MIXED, AMPLITUDE RATIO 4:1)	0.04%
POWER BANDWIDTH	DC-30 kHz
POWER OUTPUT, DIN, 8 OHM, PER CHANNEL	190 W
POWER OUTPUT, FTC AMERICAN STANDARDS, 8 OHM, PER CHANNEL	150 W
TOTAL HARMONIC DISTORTION AT RATED POWER OUTPUT	0.01%
I.M. DISTORTION AT RATED POWER OUTPUT	
(250 Hz AND 8 kHz MIXED, AMPLITUDE RATIO 4:1)	0.02%
POWER BANDWIDTH	DC-30 kHz
DAMPING FACTOR 8 OHM	65
Frequency Response	
Phono (RIAA)	±0.2 dB
Aux (±1 dB)	10 Hz - 60 kHz
Main In (±1 dB)	DC-100 kHz
Signal-to-Noise Ratio (IHF-A Network)	
Phono (MC)	76 dB
(MM)	90 dB
Aux	100 dB
Main In	110 dB
Input Terminals	
Phono: Input Impedance (MC)	50 ohms
(MM)	100 k ohms
(MM)	47 k ohms
(MM)	27 k ohms
(MM)	10 k ohms
(MM)	1 k ohms
Input Capacitance (MM)	100 pF
(MM)	150 pF
(MM)	220 pF
(MM)	330 pF
(MM)	470 pF
Input Sensitivity (MC)	100 µV
(MM)	2.0 mV

Overload Margin	42 dB
Aux: Input Impedance	40 k ohms
Input Sensitivity	150 mV
Phono Equivalent Input Noise (IHF-A Network)	
(MC)	0.07 μ V
(MM)	0.24 μ V
Phono Dynamic Range (Ratio of input overload to equivalent input noise)	120 dB
Channel Balance (0 to -40 dB/40 Hz-16 kHz)	
Phono	1.0 dB
Aux	0.5 dB
Main In	0.5 dB
Interchannel Crosstalk	
Phono 1 kHz	46 dB
Aux 1 kHz	52 dB
Tape 1 kHz	52 dB
Main In 1 kHz	52 dB
Intersource Crosstalk (Worst Point)	
1 kHz	52 dB
Output Voltage, 1 kHz	
Tape Out: Phono (MM) 7.75 mV Input	590 mV
Pre Out: Aux 775 mV Input	7.75 V
Output Impedance, 1 kHz	
Tape Out	110 ohms
Pre Out	100 ohms

GENERAL

Power Requirements	220 V AC, 50 Hz
(E and N versions are featuring an external voltage selector for use on 110/120/240 V. Other versions can be converted by a qualified technician to operate on 110/120/240 V.)	
Power Consumption at Rated Output, Both Channels Operating	575 W
Idling Power	90 W
Semiconductor Complement	
Transistors	150
Diodes	73
Field Effect Transistors	18
Dimensions	
Panel Width	16-3/8" (416 mm)
Panel Height	5-3/4" (146 mm)
Depth	17-3/16" (436 mm)
Weight	
Unit alone	53.9 lbs (24.5 kg)
Packed for shipment	58.3 lbs (26.5 kg)

