

SERVICE
MANUAL 2010

marantz

model 2010

Stereophonic Receiver

TABLE OF CONTENTS

SECTION	PAGE
Introduction	1
Service Notes	1
AM Tuner	1
FM Tuner	2
Phono and Pre-amplifier	3
Main amplifier	3
Audio Trouble Analysis	3
Test Equipment Required for Servicing	4
AM Alignment Procedure	5
FM Alignment Procedure	5
Audio Adjustment	6
Parts List	15
Technical Specifications	23

LIST OF ILLUSTRATIONS

FIGURE NO	PAGE
1. Dial Stringing	6
2. Front Panel Adjustment and Component Locations	7
3. Main Chassis Component Locations (Top View)	7
4. Rear Panel Adjustment and Component Locations	8
5. Main Chassis Component Locations (Bottom View)	8
6. FM/AM Tuner Assembly P100 Component Locations	9
7. Phono Amplifier Assembly P300 Component Locations	9
8. Tape Moni, Mono, Loudness and Muting Switch Unit Assembly P400 Component Locations	10
9. Tone Amplifier Assembly P500 Component Locations	10
10. Power Amplifier Assembly P600 Component Locations	11
11. Power Supply Assembly P800 Component Locations	12
12. Schematic Diagram	13-14

INTRODUCTION

This service manual was prepared for use by Authorized Warranty Stations and contains service information for Marantz Model 2010 Stereophonic Receiver.

Servicing information and voltage data included in this manual are intended for use by the knowledgeable and experienced technician only. All instruction should be read carefully. No attempt should be made to proceed without a good understanding of the operation in the receiver.

The part lists furnish information by which replacement part may be ordered from the Marantz Company. A simple description is included for parts which can be usually be obtained through local suppliers.

1. Service Notes

As can be seen from the circuit diagram, the chassis of Model 2010 consists of the following units. Each unit mounted on a printed circuit board is described within the square enclosed by a bold dotted line on the circuit diagram.

1. FM/AM Tuner mounted on P.C. Board P100
2. MPX Stereo Indicator mounted on P.C. Board P200
3. Phono Amplifier mounted on P.C. Board P300
4. Tape Mon, Mono, Loudness and Muting Switch Unit mounted on P.C. Board P400
5. Tone Amplifier mounted on P.C. Board P500
6. Power Amplifier mounted on P.C. Board P600
7. Temperature Compensation unit mounted on P.C. Board P700
8. Power Supply mounted on P.C. Board P800

2. AM Tuner

All components except ferrite bar antenna are mounted on a printed circuit board P100.

The AM signals induced in a ferrite bar antenna are applied to the base of converter transistor H113 through a capacitor of C171, while the local oscillator voltage is injected to the emitter of H113 through a capacitor C172. Both AM signals and oscillating voltage are mixed at the base-emitter junction and converted into 455KHz intermediate frequency. The resulting IF signal is applied to the first IF transformer L116 consisting of one ceramic filter and two tuned circuits.

The output of L116 is led to the transistor H104 which in turn apply its output to the transistor of next stage H105. The fully amplified IF output is then applied to the diode H123 to detect audible signal through the detector transformer L117. The detected audio signal is filtered and the final audio output is obtained from the pin terminal J118 and applied to the function switch.

The DC component of the detected IF signal is used as a AGC voltage to control emitter current of H104 through the resistor R185. A part of IF signal output is also applied to the diode H124 through a capacitor C180 and rectified to obtain DC current for energizing the AM signal strength meter M001.

2.1 Suggestions for AM Tuner trouble shooting

Check for broken AM bar antenna, next try to tune station by rotating fly-wheel tuning knob slowly and observe the AM signal strength meter whether it deflects or not. If the signal strength meter gives a deflection at several frequencies received, no failure may exist in the stages at least preceding final IF transformer L117. Next connect a oscilloscope to the pin terminal J118 and check for audio signals with the tuning meter deflected. If the signal strength meter does not deflect, check the local oscillator circuit. Normal oscillating voltage at the hot end of the oscillator tuning capacitor is about 2 or 3 volts, varying with tuning capacitor position. When measuring oscillating voltage use a RF VTVM, no circuit tester gives correct indication. If the local oscillator voltage is normal, check all voltage distribution in the AM circuits by using a DC VTVM and compare the measured values with those given in the schematic diagram.

INTRODUCTION

This service manual was prepared for use by Authorized Warranty Stations and contains service information for Marantz Model 2010 Stereophonic Receiver.

Service information and voltage data included in this manual are intended for use by the knowledgeable and experienced technician only. All instruction should be read carefully. No attempt should be made to proceed without a good understanding of the operation in the receiver.

The part lists furnish information by which replacement part may be ordered from the Marantz Company. A simple description is included for parts which can be usually be obtained through local suppliers.

1. Service Notes

As can be seen from the circuit diagram, the chassis of Model 2010 consists of the following units. Each unit mounted on a printed circuit board is described within the square enclosed by a bold dotted line on the circuit diagram.

1. FM/AM Tuner mounted on P.C. Board P100
2. MPX Stereo Indicator mounted on P.C. Board P200
3. Phono Amplifier mounted on P.C. Board P300
4. Tape Mon, Mono, Loudness and Muting Switch Unit mounted on P.C. Board P400
5. Tone Amplifier mounted on P.C. Board P500
6. Power Amplifier mounted on P.C. Board P600
7. Temperature Compensation unit mounted on P.C. Board P700
8. Power Supply mounted on P.C. Board P800

2. AM Tuner

All components except ferrite bar antenna are mounted on a printed circuit board P100.

The AM signals induced in a ferrite bar antenna are applied to the base of converter transistor H113 through a capacitor of C171, while the local oscillator voltage is injected to the emitter of H113 through a capacitor C172. Both AM signals and oscillating voltage are mixed at the base-emitter junction and converted into 455KHz intermediate frequency. The resulting IF signal is applied to the first IF transformer L116 consisting of one ceramic filter and two tuned circuits.

The output of L116 is led to the transistor H104 which in turn apply its output to the transistor of next stage H105. The fully amplified IF output is then applied to the diode H123 to detect audible signal through the detector transformer L117. The detected audio signal is filtered and the final audio output is obtained from the pin terminal J118 and applied to the function switch.

The DC component of the detected IF signal is used as a AGC voltage to control emitter current of H104 through the resistor R185. A part of IF signal output is also applied to the diode H124 through a capacitor C180 and rectified to obtain DC current for energizing the AM signal strength meter M001.

2.1 Suggestions for AM Tuner trouble shooting

Check for broken AM bar antenna, next try to tune station by rotating fly-wheel tuning knob slowly and observe the AM signal strength meter whether it deflects or not. If the signal strength meter gives a deflection at several frequencies received, no failure may exist in the stages at least preceding final IF transformer L117. Next connect a oscilloscope to the pin terminal J118 and check for audio signals with the tuning meter deflected. If the signal strength meter does not deflect, check the local oscillator circuit. Normal oscillating voltage at the hot end of the oscillator tuning capacitor is about 2 or 3 volts, varying with tuning capacitor position. When measuring oscillating voltage use a RF VTVM, no circuit tester gives correct indication. If the local oscillator voltage is normal, check all voltage distribution in the AM circuits by using a DC VTVM and compare the measured values with those given in the schematic diagram.

3. FM Tuner

All components are mounted on a printed circuit board P100.

FM signals induced by a FM antenna are led to FM antenna coil L101. These signals are then applied to the FET RF amplifier which in turn applies its output to the next transistor mixer H102 through a high Q tuned circuit. The mixer convert its input signal into 10.7MHz intermediate Frequency and amplifies it at the same time. The H103 is a local oscillator and its output is injected into the base of mixer transistor, the injection voltage is about 40mV.

The 10.7MHz front end output is led to the next IF section. The IF section consists of five stage of IF amplifier and one stage of sub IF amplifier.

Two pieces of ceramic filters are also used to obtain high selectivity, a pair of symmetrical diode limiters are also employed for the best limiting characteristics, improved capture ratio and good AM suppression. A part of IF amplifier H105 output is rectified by the diode H115, H116 and its DC output is fed back to the gate of FET RF amplifier to decrease the gain with increased signal strength.

3.1 Muting and Auto-Stereo Switching Circuits

The muting circuit consisting of all solid-state electrical switching has been incorporated in the Model 2010.

The DC voltage obtained by rectifying the sub IF output signal from the H109 is applied to the base of H110 and turns on it, if the sub IF output is greater than predetermined level (muting threshold level). When H110 turns on, the muting switch transistor H111 is turned on, thus decreasing the emitter collector resistance to near zero ohm and allowing emitter current path to the Final IF amplifier H108. When the input signal is lower than the predetermined level, the DC output obtained is small and can not turn on the H110, thus the H110 keeps its turn off state and this makes the switch transistor keep H111 turn off, then no emitter current is supplied to the H108 and signals below the threshold level are muted out.

The muting threshold level can be varied by adjusting the trimming resistor R153.

The DC voltage obtained is also used to make the Auto-Stereo switching transistor H112 turn on and off, and used to energizing the signal strength merer M001.

3.2 MPX Stereo Decoding Circuit

A Non-equalized audio signal from the FM detector is applied through the phase adjuster network of C148 and C161 to input terminal pin ① on the MPX decoder IC H114. The MPX decoder IC consists of a stereo decoder and postamplifier for the output. The right and left channel signals decoded by the stereo decoder H114, appear at pin ⑩ (right channel) and pin ⑪ (left channel), respectively. These signals are passed through the low-pass filters and de-emphasis networks to eliminate undesirable residual switching signals and are then delivered to postamplifier input pin ⑤ (right channel) and pin ⑦ (left channel), respectively. The signals amplified in the postamplifiers to the required levels (approximately 10 dB) are delivered to pin ⑥ (right channel) and pin ⑧ (left channel), and are then passed through C169 and C168 to pin terminals J114 and J115, hence, to the function switches.

Pin ⑮ on the MPX IC H114 is connected through R163 to the collector of the autostereo switch transistor H112, which turns on or off according to the incoming FM signal strength, thereby automatically switching between the stereophonic and monaural operations. The H112 turns on or off in accordance with whether the FM signal strength is more or less than approximately 25 μ V.

3.3 Suggestion for Trouble Shooting of FM Tuner

3.3.1 Symptom: No. FM Reception

First turn on the Power switch and try to tune FM stations. Rotate the fly-wheel tuning knob slowly and observe the FM signal strength meter. If the signal strength meter deflect at several frequencies received, the tuner circuits preceding the discriminator circuit may have no failure.

When no reading is obtained in the meter, check FM local oscillator circuit, using a RF VTVM. The normal local oscillator voltage is one or two volts (rms) at the tuning capacitor, depending on the tuning capacitor position. If the local oscillator voltage is normal, next check all voltage distribution in the FM Front End and IF amplifier unit and compare them with those shown in the circuit diagram. When signal strength meter deflects but no sound is obtained, check audio circuits, using high sensitive oscilloscope.

3.3.2 Symptom: No Stereo Separation

First check the "MONO" switch is in normal out position. Connect a FM RF signal generator output modulated by a stereo modulator to the rear FM antenna terminals, and check the stereo beacon is turned on or not. If not turned on, check for 19 KHz pilot signal and 38 KHz switching signal, using an oscilloscope.

4. Phono and Pre-amplifier

Signals from the tuner and AUX jacks are applied to the selector switch. Signals from the PHONO jacks are applied to the phono-amplifier consisting of transistor H301 and H303. The gain of the amplifier is 37 dB. The amplified and equalized phono-signals are, then, fed to other section of the selector switch which, in turn, applies output signals from the tuner, phono-amplifier and AUX jacks to the TAPE MONITOR switch and TAPE OUT jacks. The TAPE MONITOR switch applies the signals to the balance and volume controls.

The controlled signals are fed to the pre-amplifier consisting of H501. Frequency response of the amplifier can be varied by BASS and TREBLE controls. The controlled output are then led to the main amplifier.

5. Main Amplifier

Transistor H601 is a pre-driver coupled to the transistor H603 through capacitor C611. Transistor H603 drives the inverter transistors H615 and H617 which, in turn, drive the power stage consisting of H001 and H002. Transistors H611 and H613 are current limiters and operate as power protecting circuits.

Excessive currents flowing into the power stage are detected by the resistors R645 and R650 and the resultant variations are applied to the transistors H611 and H613 and make them turned on. This decreases the current flowing into the H615 and H617. In this way the currents flowing in the power stage (H001 and H002) are restricted within a safe value.

6. Audio Trouble Analysis

1. Excessive line consumption
 - a. Check for shorted rectifiers H802, H803, H804, H805, H806 and H807.
 - b. Check for shorted transistors H001, H002. Check L002 for short.
2. No line consumption or zero bias.
 - a. Check line cord, fuse, shorted H701, H702, H605 and H606.
 - b. Check for open rectifiers H802, H803, H804, H805, H806 and H807 or open L002.
3. High hum and noise level.
 - a. Check filter capacitors C004, C601 and C602.
4. Parastic oscillation
 - a. Check for defective capacitors, C607, C608, C613, C614, C617 and C618.
5. Improper clipping
 - a. Check for proper adjustment of R615 and R616.

7. Test Equipment Required for Servicing

Table 1 lists the test equipment required for servicing the Model 2010 Receiver.

Item	Manufacturer and Model No.	Use
AM Signal Generator		Signal source for AM alignment
Test Loop		Used with AM Signal generator
FM Signal Generator	Less than 0.3% distortion	Signal source for FM alignment
Stereo Modulator	Less than 0.3% distortion	Stereo separation alignment and trouble shooting
Audio Oscillator	Weston Model CVO-100P, less than 0.02% residual distortion is required.	Sinewave and squarewave signal source.
Oscilloscope	High sensitivity with DC horizontal and vertical amplifiers.	Waveform analysis and Trouble Shooting, and ASO alignment.
VTVM	With AC, DC, RF range	Voltage measurements.
Circuit Tester		Trouble Shooting
AC Wattmeter	Simpson, Model 390	Monitors primary power to Amplifier
AC Ammeter	Commercial Grade (1-10A)	Monitors amplifier output under short circuit condition.
Line Voltmeter	Commercial Grade (0-150VAC)	Monitors potential of primary power to amplifier
Variable Autotransformer (0-140VAC, 10 amps.)	Powerstat, Model 116B	Adjusts level of primary power to amplifier.
Shorting Plug	Use phono plug with 600 ohm across center pin and shell.	Shorts amplifier input to eliminate noise pickup.
Output Load (8 ohms, 0.5%, 100W)	Commercial Grade	Provides 8-ohm load for amplifier output termination.
Output Load (4 ohms, 0.5%, 100W)	Commercial Grade	Provides 4-ohm load for amplifier output termination.

8. AM Alignment Procedure

8.1 AM IF Alignment

1. Connect a sweep generator to the test point (A) or J107 and an alignment scope to the test point (B).
2. Rotate each core of IF transformer L116 and L117 for maximum height and flat top symmetrical response.

8.2 AM Frequency Range and Tracking Alignment

1. Set AM signal generator to 525 KHz. Turn the tuning capacitor fully closed (place the tuning pointer at the low end.) and adjust the oscillator coil L115 for maximum audio output.
2. Set the signal generator to 1650 KHz. Place the tuning pointer in the high frequency end and adjust the oscillator trimmer on the oscillator tuning capacitor (CA-2) for maximum audio output.
3. Repeat the step 1 and 2 until no further adjustment is necessary.
4. Set the generator to 600 KHz and tune the receiver to the same frequency and adjust a slug core of AM ferrite rod antenna for maximum output.
5. Set the generator to 1400 KHz and tune the receiver to the same frequency and adjust the trimming capacitors of Antenna (CA-1) for maximum output.
6. Repeat the step 4 and 5 until no further adjustment is necessary.

Note: During tracking alignment reduce the signal generator output as necessary to avoid AGC action.

9. FM Alignment Procedure

1. Connect a FM signal generator to the FM antenna terminals and a oscilloscope and an audio distortion analyzer to the tape output jacks on the rear panel.
2. Set the FM SG to 87.5 MHz and provide about 3 to 5 μ V. Place the tuning pointer at the low frequency end by rotating the tuning knob and adjust the core of oscillator coil L103 to obtain maximum audio output.
3. Set the FM SG to 108.5 MHz and provide about 3 to 5 μ V output. Rotate the tuning knob and place the tuning pointer at the high frequency end and adjust the trimming capacitor C187 for Maximum output.
4. Repeat the step 2 and 3 until no further adjustment is necessary.
5. Set the FM SG to 90 MHz and tune the receiver to the same frequency. Decrease signal generator output until the audio output level decreases with the decreasing generator output. Adjust the antenna coil L101, RF coil L102 and IF transformer L105 for minimum audio distortion.
6. Set the FM SG to 106 MHz and tune the receiver to the same frequency. Adjust the trimming capacitor CF-1, CF-2 for minimum distortion.
7. Repeat the step 5 and 6 until no further adjustment is necessary.
8. Connect a DC VTVM with 1 volt range selected to the test point (E)(J120) and adjust the secondary core (upper) of discriminator transformer L107 so that no voltage reading is obtained on the VTVM at no signal.
Next set the FM SG to 98 MHz and increase the output level to 1 K μ V, then tune the receiver to the same frequency so that no deflection is obtained on the VTVM.
Adjust primary core (bottom) of L107 for minimum distortion, and adjust the L108 for the maximum deflection of FM signal strength meter M001.

9.1 STEREO Separation Alignment

1. Set the FM SG to provide 1 K μ V at 98 MHz.
Tune the receiver to the same frequency perfectly (so that the VTVM connected to the test point (E) gives no reading).

2. Modulate the FM SG with stereo composite signal consisting of subchannel signal only (of course a pilot signal must be included).

Adjust the core of L110 for maximum audio output, then, modulate the FM SG with a stereo composite signal consisting of L or R channel only, and adjust the trimming resistor R161 for maximum and equal separation in both channels.

9.2 Muting Circuit Alignment

1. Set the FM SG output to provide 25 μ V (IHF) at 98 MHz and tune the receiver to the same frequency.

Adjust the trimming resistor R153 for the threshold level of 25 μ V (during this adjustment turn the MUTING pushswitch "on").

10. Audio Adjustment

1. Connect a VTVM across the resistor R647 and adjust the trimming resistor R627 until the VTVM reads 7.5 mV DC.

For the other channel connect the VTVM across the R648 and adjust the R628 for the same reading.

2. Connect an oscilloscope across the speaker terminals. Apply an audio signal of 1 KHz to the AUX jacks and increase the audio signal until the audio output on the scope begin to start clipping.

Adjust the trimming resistor R615 for equal and symmetrical clipping.

For the other channel adjust the R616.

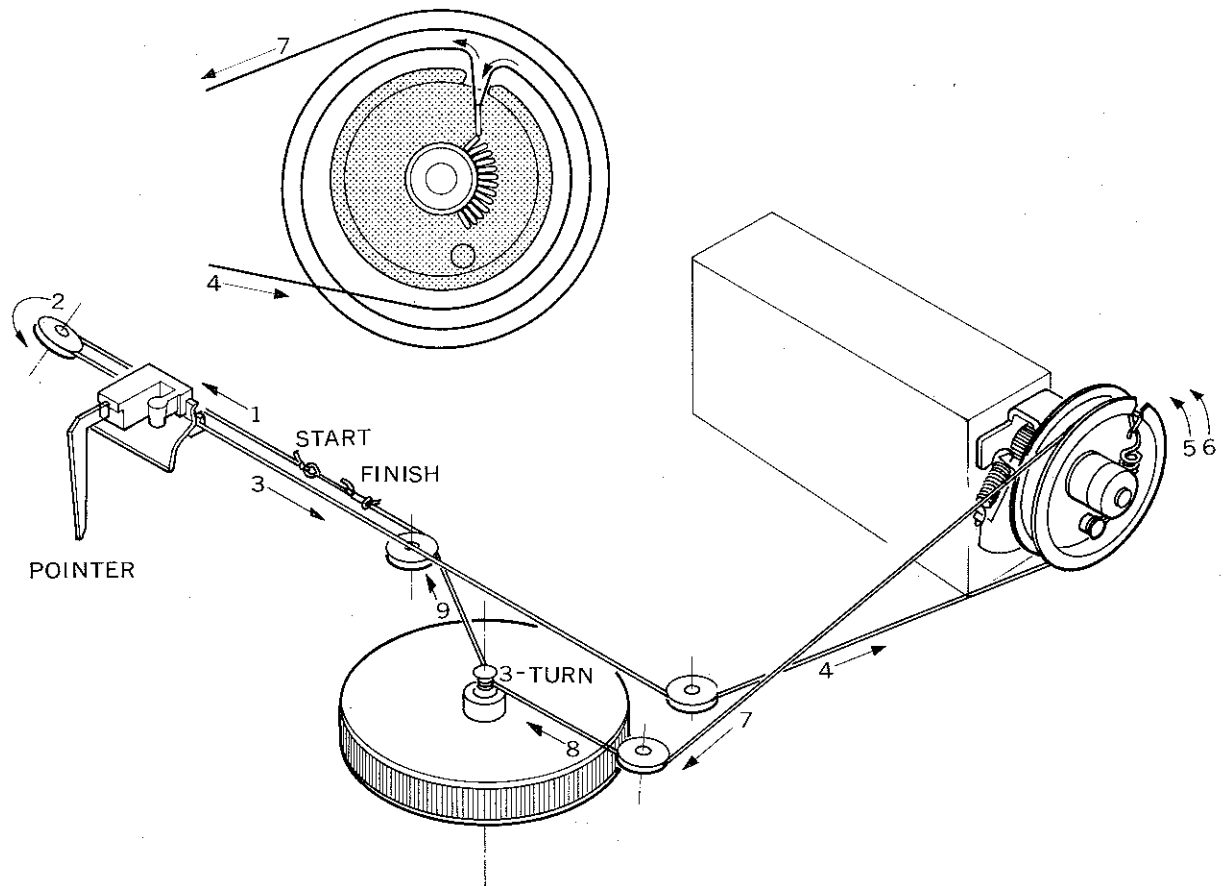
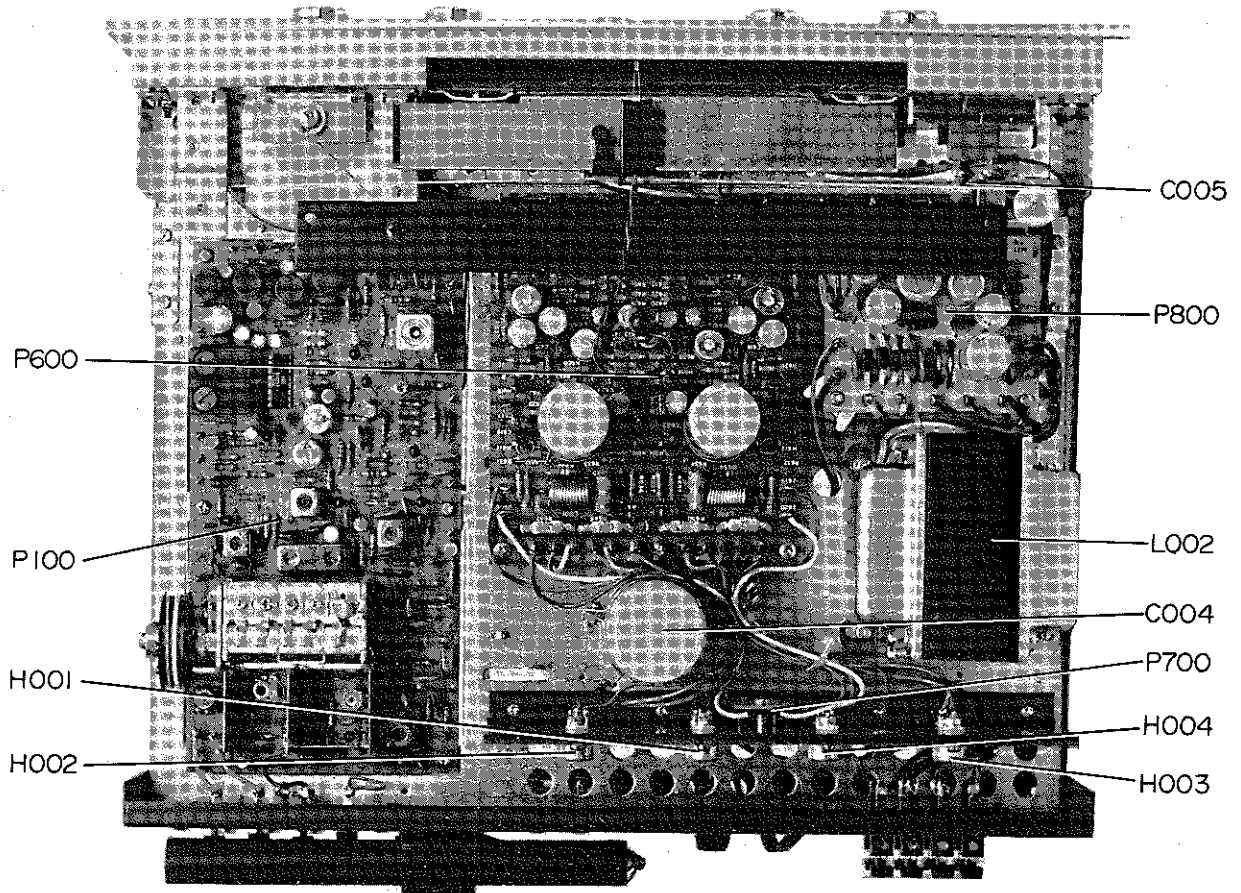
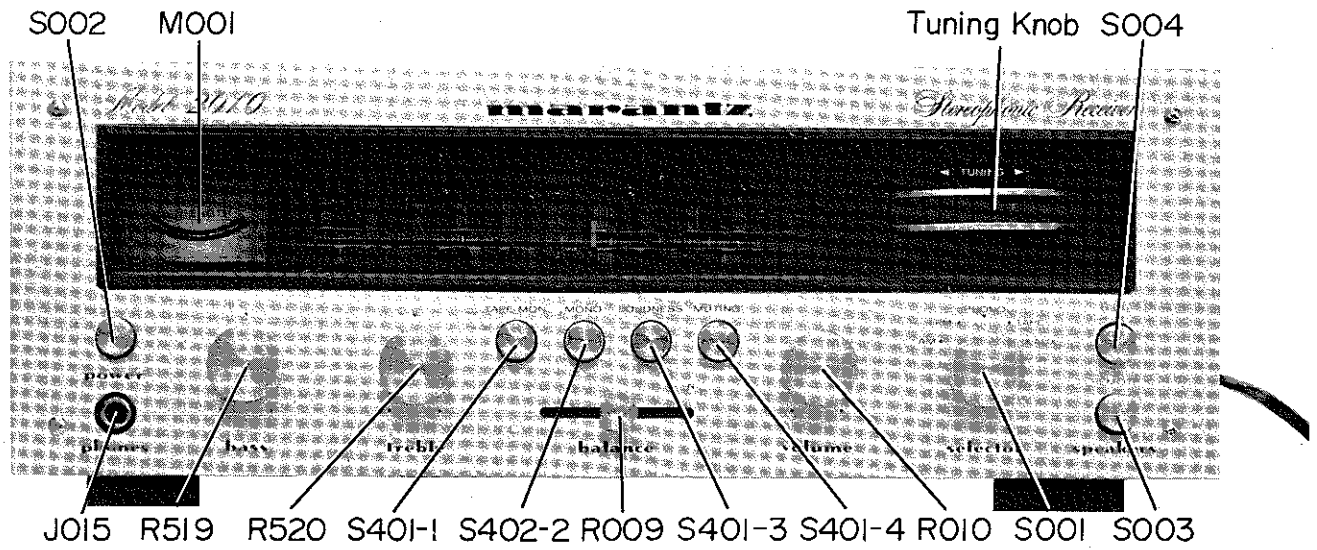

Figure 1. Dial Stringing



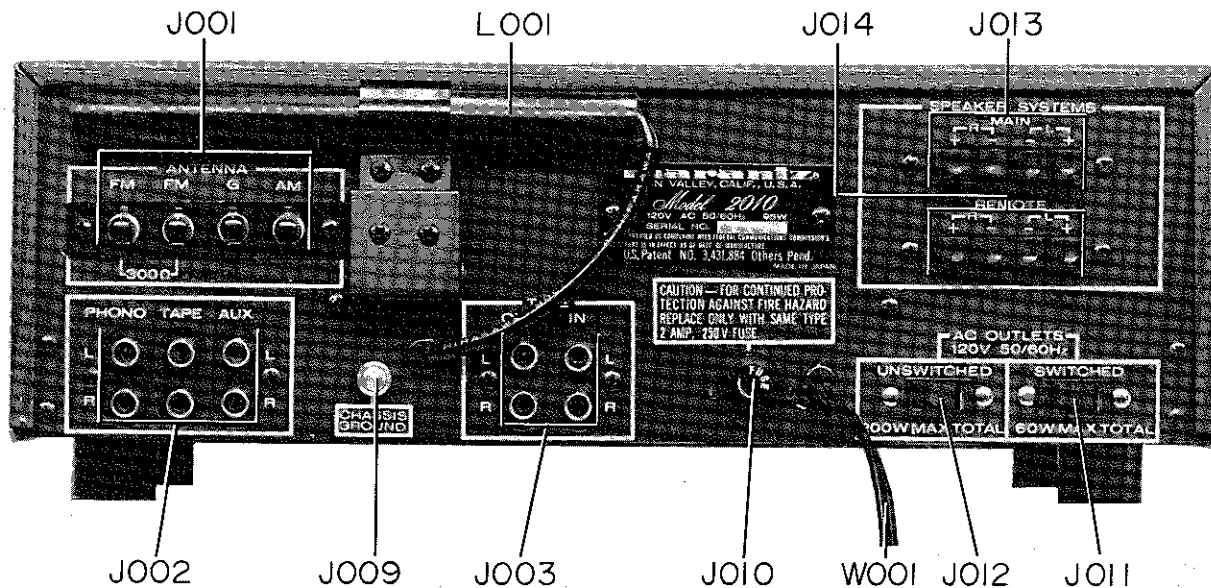

Figure 4. Rear Panel Adjustment and Component Locations

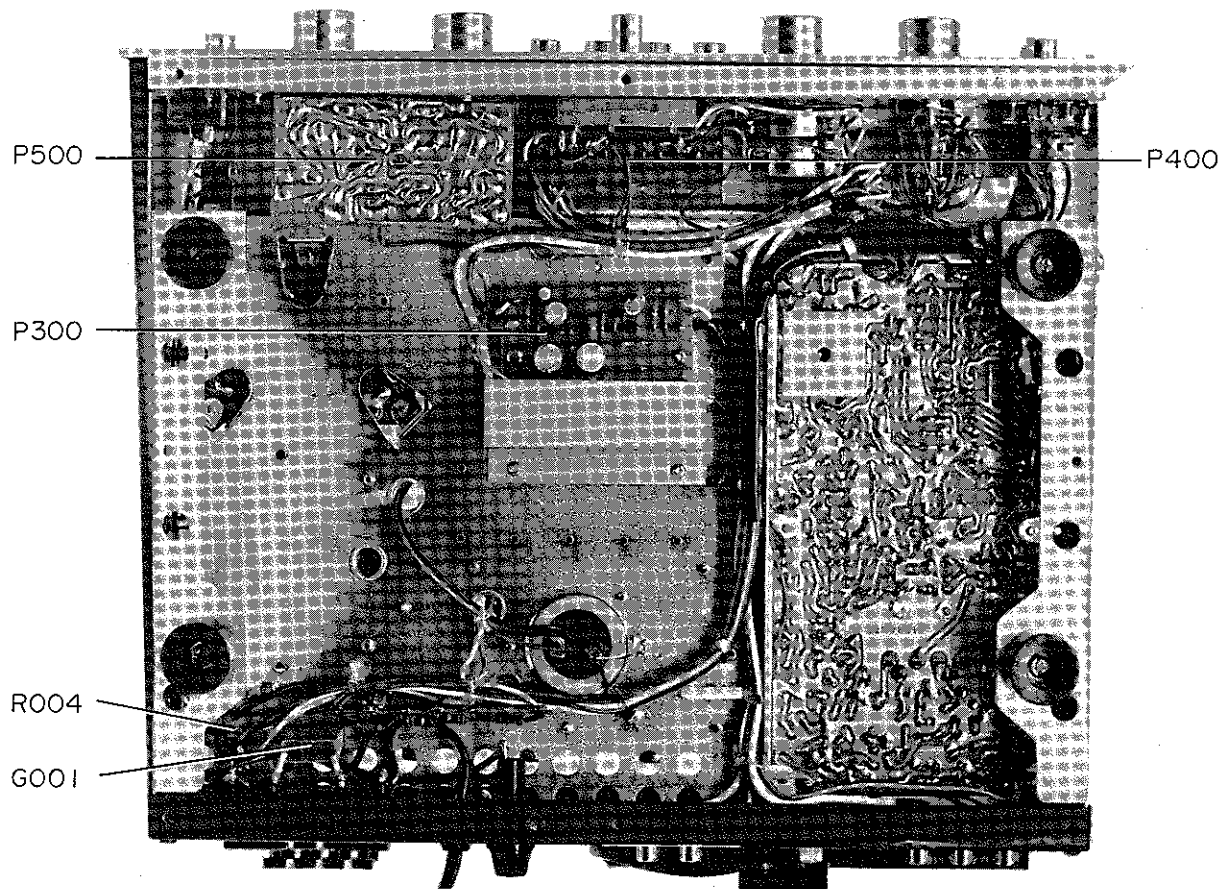

Figure 5. Main Chassis Component Locations (Bottom View)

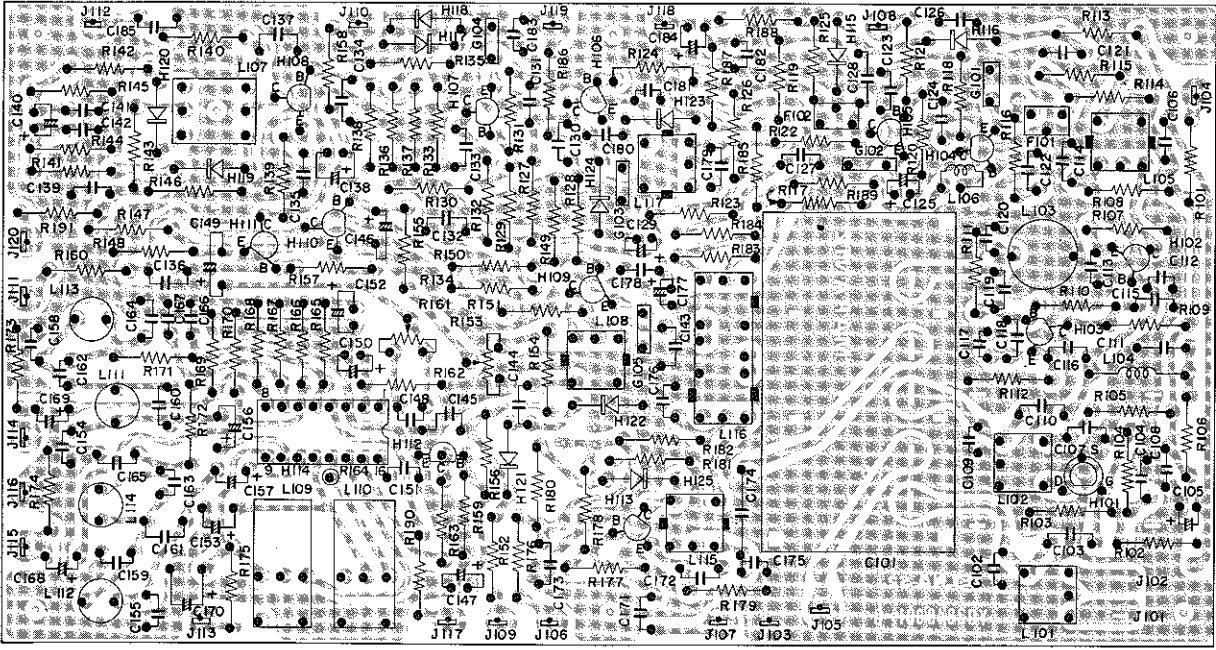

Figure 6. FM/AM Tuner Assembly P100 Component Locations

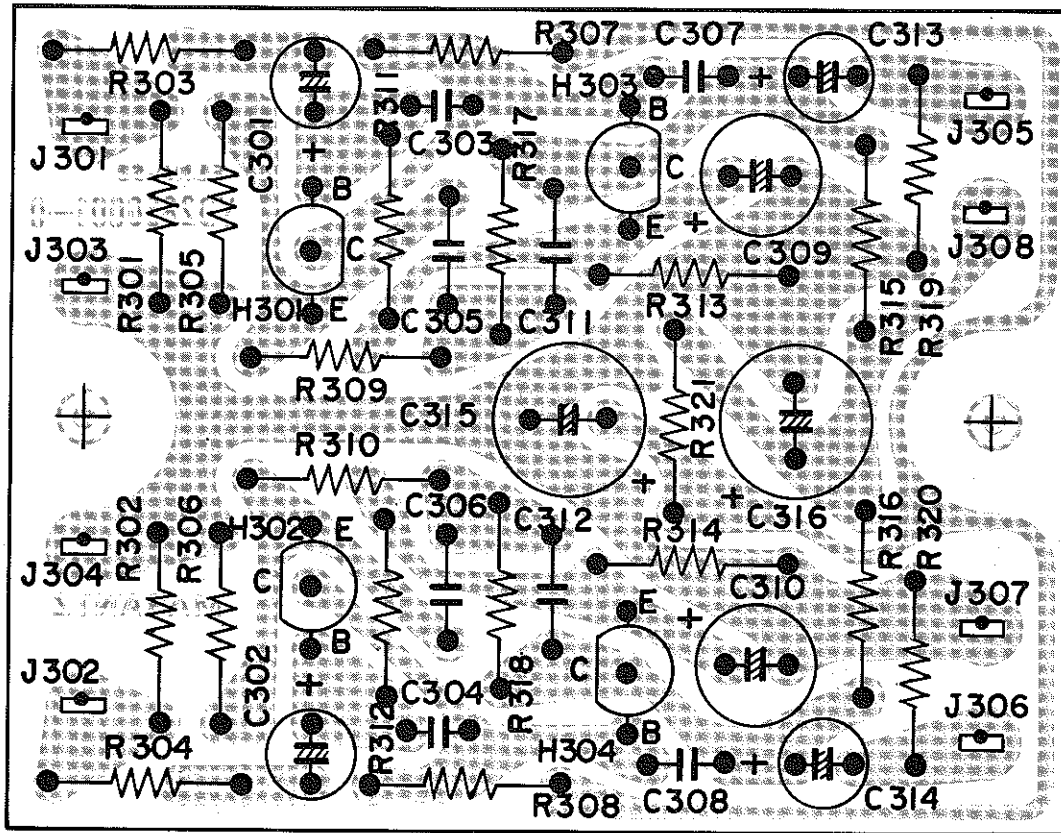

Figure 7. Phono Amplifier Assembly P300 Component Locations

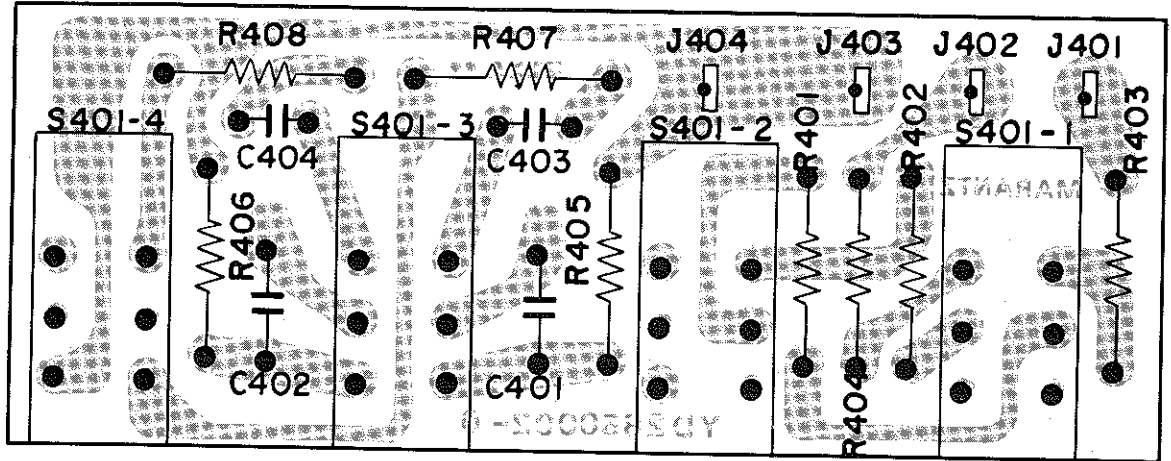

Figure 8. Tape Moni, Mono, Loudness and Muting Switch Unit Assembly P400 Component Locations

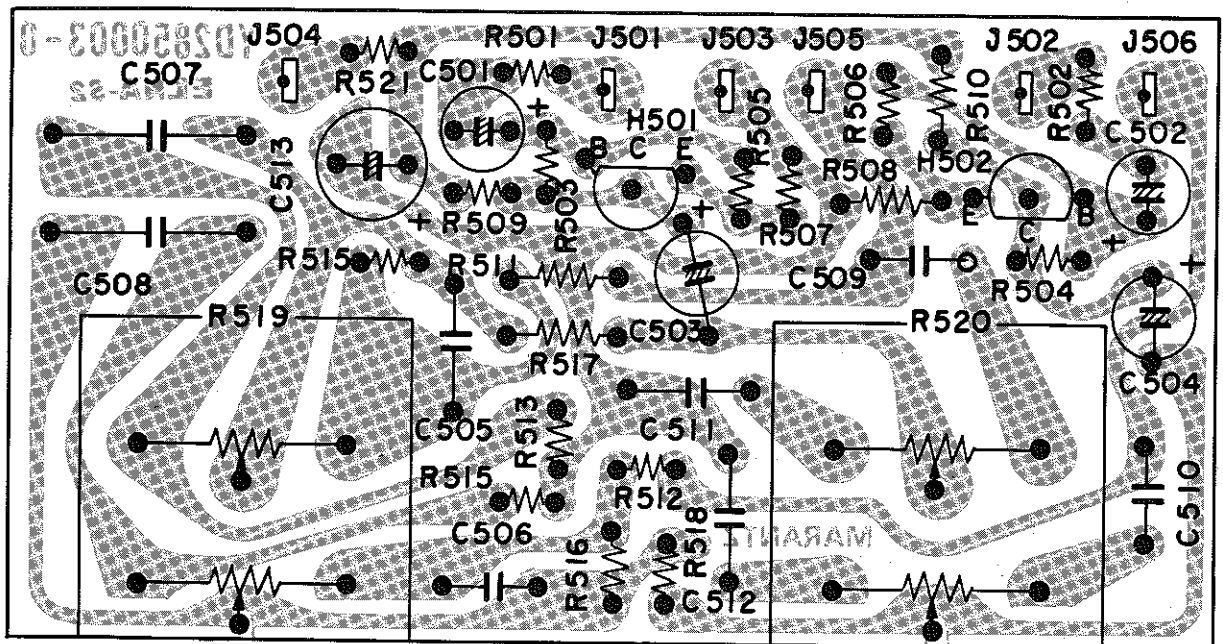

Figure 9. Tone Amplifier Assembly P500 Component Locations

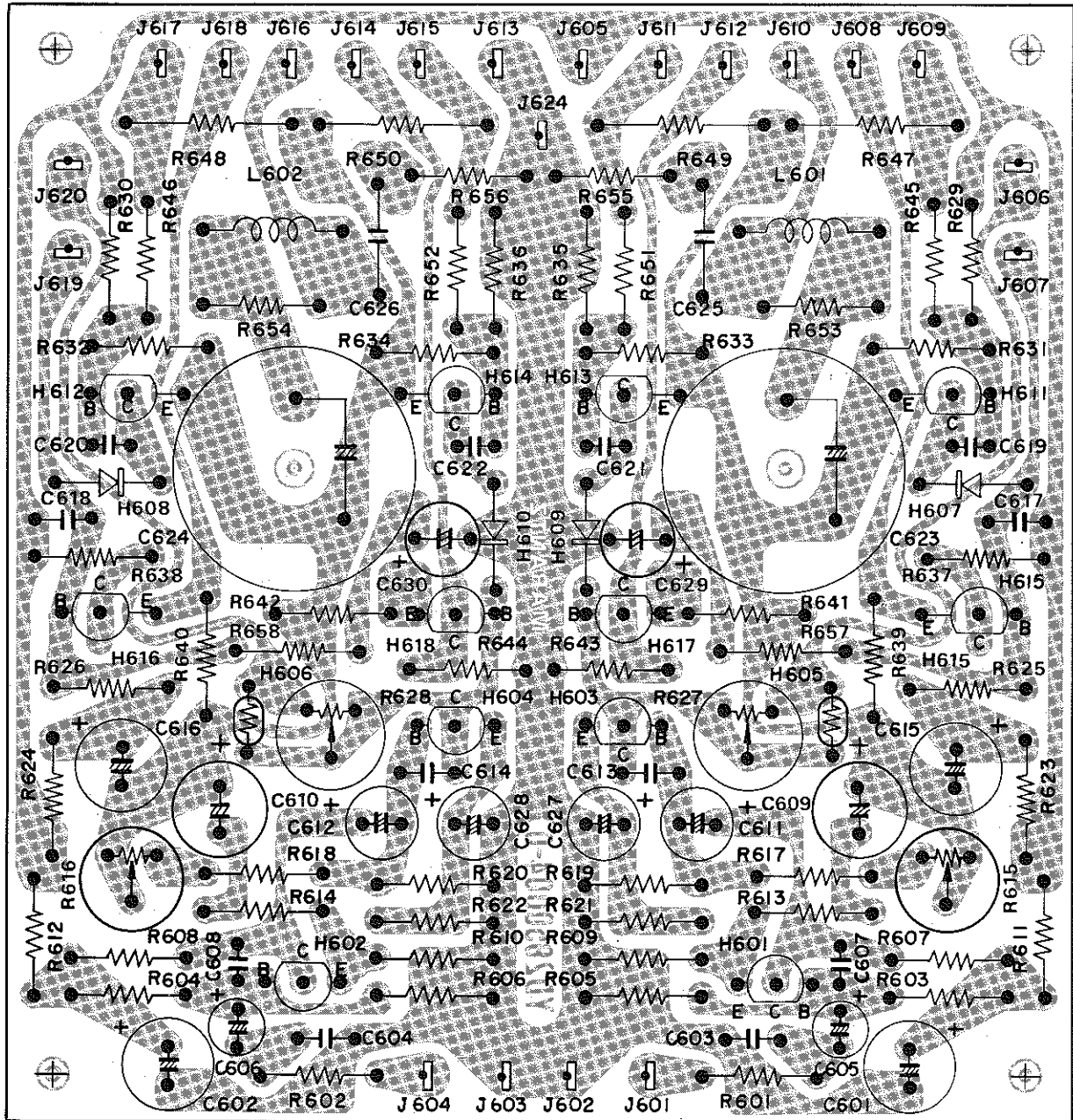

Figure 10. Power Amplifier Assembly P600 Component Locations

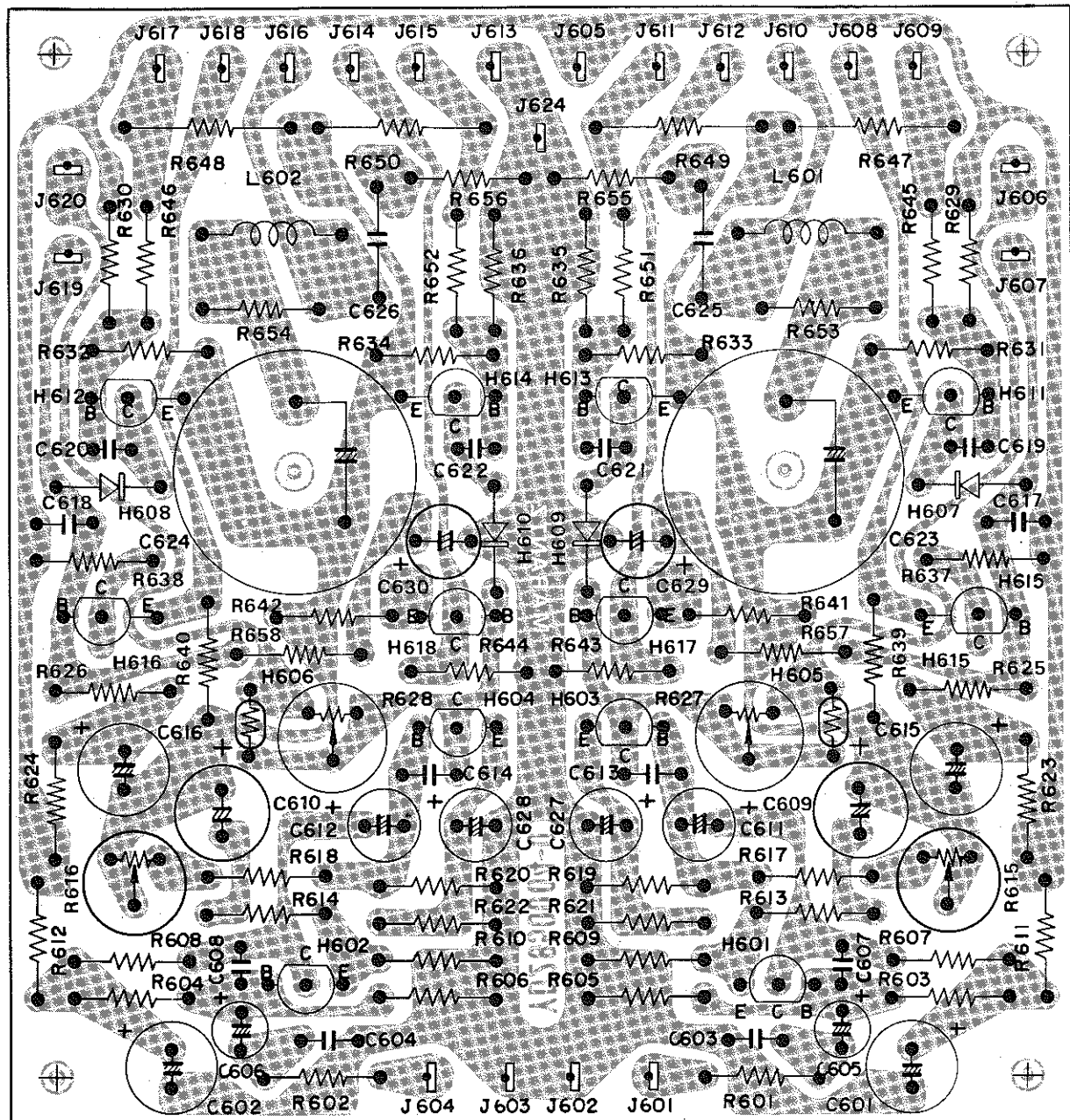

Figure 10. Power Amplifier Assembly P600 Component Locations

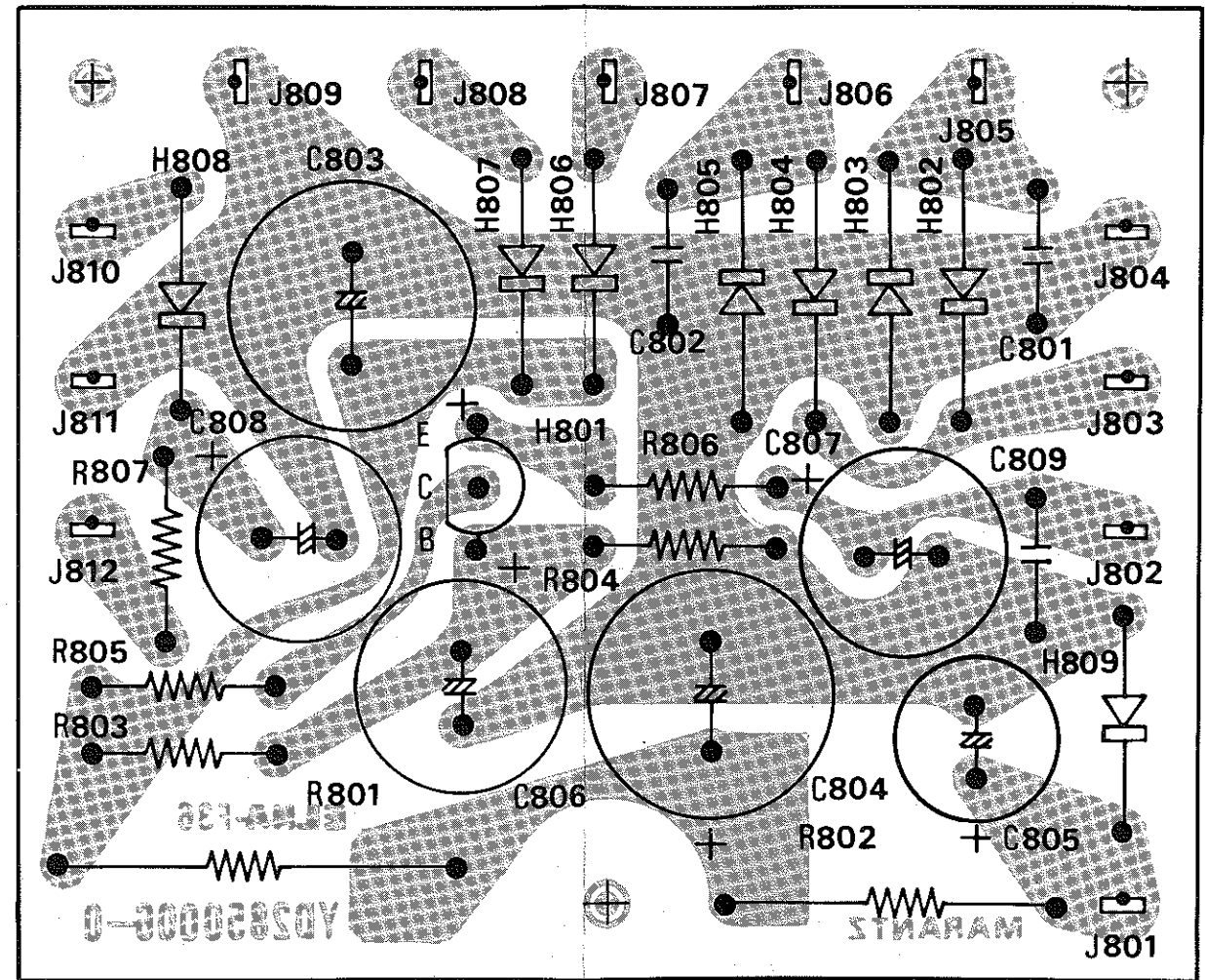

Figure 11. Power Supply Assembly P800 Component Locations

PARTS LIST

REF. DESIG.	MARANTZ PART NO.	DESCRIPTION
P100	YD2849001 (ZZ 2849001)	P. C. Board P. C. Board Assy
		RESISTORS (All resistors are ±5%, ¼W and carbon type, unless otherwise indicated.)
R101	RT0510114	100Ω
R102	RT0556314	56KΩ
R103	RT0510514	1MΩ
R104	RT0510414	100KΩ
R105	RT0510114	100Ω
R106	RT0510514	1MΩ
R107	RT0510214	1KΩ
R108	RT0510114	100Ω
R109	RT0510114	100Ω
R110	RT0510314	10KΩ
R111	RT0510314	10KΩ
R112	RT0512214	1.2KΩ
R113	RT0533314	33KΩ
R114	RT0547114	470Ω
R115	RT0515114	150Ω
R116	RT0515114	150Ω
R117	RT0522214	2.2KΩ
R118	RT0515214	1.5KΩ
R119	RT0510114	100Ω
R120	RT0556214	5.6KΩ
R121	RT0512314	12KΩ
R122	RT0510214	1KΩ
R123	RT0510114	100Ω
R124	RT0515114	150Ω
R125	RT0515214	1.5KΩ
R126	RT0533214	3.3KΩ
R127	RT0510214	1KΩ
R128	RT0533214	3.3KΩ
R129	RT0515314	15KΩ
R130	RT0527214	2.7KΩ
R131	RT0515114	150Ω
R132	RT0533114	330Ω
R133	RT0515114	150Ω
R134	RT0510114	100Ω
R135	RT0510414	100KΩ
R136	RT0515114	150Ω
R137	RT0582214	8.2KΩ
R138	RT0515314	15KΩ
R139	RT0510214	1KΩ
R140	RT0522114	220Ω
R141	RT0582114	820Ω
R142	RT0582114	820Ω
R143	RT0510114	100Ω
R144	RT0568214	6.8KΩ
R145	RT0568214	6.8KΩ
R146	RT0518314	18KΩ
R147	RT0515314	15KΩ
R148	RT0522314	22KΩ
R149	RT0582214	8.2KΩ
R150	RT0515314	15KΩ
R151	RT0510114	100Ω
R152	RT0533314	33KΩ
R153	RA0104015	Trimming, 100KΩ (B)
R154	RT0522314	22KΩ
R155	RT0522314	22KΩ
R156	RT0547314	47KΩ

REF. DESIG.	MARANTZ PART NO.	DESCRIPTION
R157	RT0533214	3.3KΩ
R158	RT0510114	100Ω
R159	RT0518314	18KΩ
R160	RT0510014	10Ω
R161	RA0103020	Trimming, 10KΩ (B)
R162	RT0547214	4.7KΩ
R163	RT0518214	1.8KΩ
R164	RT0533414	330KΩ
R165	RT0568414	680KΩ
R166	RT0510414	100KΩ
R167	RT0568414	680KΩ
R168	RT0510414	100KΩ
R169	RT0543214	4.3KΩ
R170	RT0543214	4.3KΩ
R171	RT0510214	1KΩ
R172	RT0510214	1KΩ
R173	RT0522414	220KΩ
R174	RT0522414	220KΩ
R175	GT0515212	1.5KΩ, ±5%, ¼W
R176	RT0515214	1.5KΩ
R177	RT0568214	6.8KΩ
R178	RT0515314	15KΩ
R179	RT0527214	2.7KΩ
R180	RT0515214	1.5KΩ
R181	RT0582314	82KΩ
R182	RT0522114	220Ω
R183	RT0556214	5.6KΩ
R184	RT0582314	82KΩ
R185	RT0515314	15KΩ
R186	RT0582214	8.2KΩ
R187	RT0522214	2.2KΩ
R188	RT0547214	4.7KΩ
R189	RT0522214	2.2KΩ
R191	RT0522314	22KΩ
C101	CA3240007	Variable, FM-3, AM-2 GANG
C102	DD1210001	Ceramic, 10PF ±10%
C103	DK1710201	Ceramic, 0.001μF ±20%
C104	DK1820302	Ceramic, 0.02μF +100% - 0%
C105	EM2240251	Electroly, 0.22μF 25V
C106	DK1820302	Ceramic, 0.02μF +100% - 0%
C107	DK1820302	Ceramic, 0.02μF +100% - 0%
C108	DK1840302	Ceramic, 0.04μF +80% -20%
C109	DD1210001	Ceramic, 10PF ±10%
C110	DD1105001	Ceramic, 5PF ±0.5PF
C111	DD1530101	Ceramic, 300PF ±5%
C112	DD1615003	Ceramic, 15PF ±10%
C113	DK1710201	Ceramic, 0.001μF ±20%
C114	DK1840302	Ceramic, 0.04μF +80% -20%
C115	DK1820302	Ceramic, 0.02μF +100% - 0%
C116	DD1102004	Ceramic, 2PF ±0.5PF
C117	DD1615003	Ceramic, 15PF ±10%
C118	DD1520001	Ceramic, 20PF ±5%
C119	DD1207003	Ceramic, 7PF ±1PF
C120	DD1525002	Ceramic, 25PF ±5%
C121	DK1820302	Ceramic, 0.02μF +100% - 0%

REF. DESIG.	MARANTZ PART NO.	DESCRIPTION
C122	DD1650101	Ceramic, 500PF ±10%
C123	DK1840302	Ceramic, 0.04μF +80% -20%
C124	DK1820302	Ceramic, 0.02μF +100% -0%
C125	EA1060169	Electroly, 10μF 16V
C126	DK1840302	Ceramic, 0.04μF +80% -20%
C127	DK1840302	Ceramic, 0.04μF +80% -20%
C128	DD1620001	Ceramic, 20PF ±10%
C129	EA1060169	Electroly, 10μF 16V
C130	DD1610101	Ceramic, 100PF ±10%
C131	DK1820302	Ceramic, 0.02μF +100% -0%
C132	DK1840302	Ceramic, 0.04μF +80% -20%
C133	DK1820302	Ceramic, 0.02μF +100% -0%
C134	DK1820302	Ceramic, 0.02μF +100% -0%
C135	DK1820302	Ceramic, 0.02μF +100% -0%
C136	DK1840302	Ceramic, 0.04μF +80% -20%
C137	DK1840302	Ceramic, 0.04μF +80% -20%
C138	EA1060169	Electroly, 10μF 16V
C139	DD1650101	Ceramic, 500PF ±10%
C140	EA1060169	Electroly 10μF 16V
C141	DD1620101	Ceramic, 200PF ±10%
C142	DD1620101	Ceramic, 200PF ±10%
C143	DK1840302	Ceramic, 0.04μF +80% -20%
C144	DD1610101	Ceramic, 100PF ±10%
C145	DK1820302	Ceramic, 0.02μF +100% -0%
C146	EA1050509	Electroly, 1μF 50V
C147	EA1050509	Electroly, 1μF 50V
C148	DF1722201	Film, 0.0022μF ±20%
C149	EA3350509	Electroly, 3.3μF 50V
C150	EA1060169	Electroly, 10μF 16V
C151	DF1610201	Film, 0.001μF ±10%
C152	EA1060169	Electroly, 10μF 16V
C153	EA3360109	Electroly, 33μF 10V
C154	DF1627201	Film, 0.0027μF ±10%
C155	DF1627201	Film, 0.0027μF ±10%
C156	EA4740501	Electroly, 0.47μF 50V
C157	EA4740501	Electroly, 0.47μF 50V
C158	DF1647201	Film, 0.0047μF ±10%
C159	DF1647201	Film, 0.0047μF ±10%
C160	DF1533205	Film, 0.0033μF ±5%
C161	DF1533205	Film, 0.0033μF ±5%
C162	DF5582101	Film, 820PF ±5%
C163	DF5582101	Film, 820PF ±5%
C164	DF1618205	Film, 0.0018μF ±10%
C165	DF1618205	Film, 0.0018μF ±10%
C166	DF1615301	Film, 0.015μF ±10%
C167	DF1615301	Film, 0.015μF ±10%
C168	EA4740501	Electroly, 0.47μF 50V
C169	EA4740501	Electroly, 0.47μF 50V
C170	EA2270169	Electroly, 220μF 16V
C171	DF1768201	Film, 0.0068μF ±20%
C172	DF1722301	Film, 0.022μF ±20%
C173	DF1740301	Film, 0.04μF ±20%
C174	DF6539101	Film, 390PF ±5%

REF. DESIG.	MARANTZ PART NO.	DESCRIPTION
C175	DD1620001	Ceramic, 20PF ±10%
C176	DF1740301	Film, 0.04μF ±20%
C177	EA4760109	Electroly, 47μF 10V
C178	DK1840302	Ceramic, 0.04μF +80% -20%
C179	DD1530101	Ceramic, 300PF ±5%
C180	DD1620101	Ceramic, 200PF ±10%
C181	DF1647201	Film, 0.0047μF ±10%
C182	DF1647201	Film, 0.0047μF ±10%
C183	DK1840302	Ceramic, 0.04μF +80% -20%
C184	EA4740501	Electroly, 0.47μF 50V
C185	DK1840302	Ceramic, 0.04μF +80% -20%
C186	EA1050509	Electroly, 1μF 50V
C187	CT1100008	Trimming, 10PF
MISCELLANEOUS		
G101	BF4030001	Printed Compo., 0.04μF + 270Ω
G102	BF2230008	Printed Compo., 0.022μF + 270Ω
G103	BF2230007	Printed Compo., 0.022μF + 680Ω
G104	BF2230006	Printed Compo., 0.022μF + 1KΩ
G105	BF2230006	Printed Compo., 0.022μF + 1KΩ
F101	FF1107004	Ceramic Filter, CFS107M
F102	FF1107004	Ceramic Filter, CFS107M
COILS AND TRANSFORMERS		
L101	LA1004606	ANT Coil, FM
L102	LA1027809	RF Coil, FM
L103	LO1203601	OSC Coil, FM
L104	LC1751001	Choke Coil, 0.75μH
L105	LI1001601	IFT, FM
L106	LC1223002	Choke Coil, 22μH
L107	LI1401623	IFT, FM
L108	LI1015602	IFT, FM
L109	LS1031001	MPX Coil, 19 KHz
L110	LS1031004	MPX Coil, 38 KHz
L111	LC2226004	Choke Coil, 22 mH
L112	LC2226004	Choke Coil, 22 mH
L113	LC2226004	Choke Coil, 22 mH
L114	LC2226004	Choke Coil, 22 mH
L115	LO1001042	OSC Coil, AM
L116	LI1028002	IFT, AM
L117	LI1001048	IFT, AM
SEMICONDUCTORS		
H101	HF200411B	FET, 2SK41E
H102	HT306681C	Transistor, 2SC668C
H103	HT309301C	Transistor, 2SC930C
H104	HT309301C	Transistor, 2SC930C
H105	HT309301C	Transistor, 2SC930C
H106	HT309301C	Transistor, 2SC930C
H107	HT309301C	Transistor, 2SC930C
H108	HT309301C	Transistor, 2SC930C
H109	HT309301C	Transistor, 2SC930C
H110	HT305361G	Transistor, 2SC536G
H111	HT305361E	Transistor, 2SC536E
H112	HT305361E	Transistor, 2SC536E
H113	HT309291C	Transistor, 2SC929C
H114	HC1001703	IC, LA3310
H115	HD1000303	Diode, 1S188FM2
H116	HD1000303	Diode, 1S188FM2
H117	HD2001105	Diode, 1S1555



REF. DESIG.	MARANTZ PART NO.	DESCRIPTION	REF. DESIG.	MARANTZ PART NO.	DESCRIPTION
H118	HD2001105	Diode, 1S1555			
H119	HD1000303	Diode, 1S188FM2			
H120	HD1000303	Diode, 1S188FM2			
H121	HD1000303	Diode, 1S188FM2			
H122	HD1000303	Diode, 1S188FM2			
H123	HD1000303	Diode, 1S188FM2			
H124	HD1000303	Diode, 1S188FM2			
H125	HD1000303	Diode, 1S188FM2			
		MISCELLANEOUS			
J101	YP1000099	Plug			
J102	YP1000099	Plug			
J103	YP1000099	Plug			
J104	YP1000099	Plug			
J105	YP1000099	Plug			
J106	YP1000099	Plug			
J107	YP1000099	Plug			
J108	YP1000099	Plug			
J109	YP1000099	Plug			
J110	YP1000099	Plug			
J111	YP1000099	Plug			
J112	YP1000099	Plug			
J113	YP1000099	Plug			
J114	YP1000099	Plug			
J115	YP1000099	Plug			
J116	YP1000099	Plug			
J117	YP1000099	Plug			
J118	YP1000099	Plug			
J119	YP1000099	Plug			
J120	YP1000099	Plug			
0906	282110901	Shield			
0907	286710901	Shield			
0908	285010902	Shield			
1109	62031650W	Lug			
P300	YD2850001 ZZ2850001	P. C. Board P. C. Board Assy			
		RESISTORS (All resistors are ±5%, ¼W and carbon type, unless otherwise indicated.)			
R301	RT0547314	47KΩ			
R302	RT0547314	47KΩ			
R303	RT0539114	390Ω			
R304	RT0539114	390Ω			
R305	RT0539114	390Ω			
R306	RT0539114	390Ω			
R307	RT0568314	68KΩ			
R308	RT0568314	68KΩ			
R309	RT0522314	22KΩ			
R310	RT0522314	22KΩ			
R311	RT0533414	330KΩ			
R312	RT0533414	330KΩ			
R313	RT0539114	390Ω			
R314	RT0539114	390Ω			
R315	RT0582214	8.2KΩ			
R316	RT0582214	8.2KΩ			
R317	RT0533414	330KΩ			
R318	RT0533414	330KΩ			
R319	RT0522414	220KΩ			
R320	RT0522414	220KΩ			
R321	RT0518314	18KΩ			
C301	EM2250251	Electroly, 2.2μF ±20% 25V			CAPACITORS
C302	EM2250251	Electroly, 2.2μF ±20% 25V			
C303	DD1650001	Ceramic, 50PF ±10% 50V			
C304	DD1650001	Ceramic, 50PF ±10% 50V			
C305	DF1633205	Film, 0.0033μF ±10% 50V			
C306	DF1633205	Film, 0.0033μF ±10% 50V			
C307	DD1650001	Ceramic, 50PF ±10% 50V			
C308	DD1650001	Ceramic, 50PF ±10% 50V			
C309	EA1070109	Electroly, 100μF ±10V			
C310	EA1070109	Electroly, 100μF 10V			
C311	DF1610305	Film, 0.01μF ±10% 50V			
C312	DF1610305	Film, 0.01μF ±10% 50V			
C313	EV1050351	Electroly, 1μF ±20% 35V			
C314	EV1050351	Electroly, 1μF ±20% 35V			
C315	EA1070359	Electroly, 100μF 35V			
C316	EA4760509	Electroly, 47μF 50V			
J301	YP1000094	Plug			MISCELLANEOUS
J302	YP1000094	Plug			
J303	YP1000094	Plug			
J304	YP1000094	Plug			
J305	YP1000094	Plug			
J306	YP1000094	Plug			
J307	YP1000094	Plug			
J308	YP1000094	Plug			
H301	HT31327 2B	Transistor, 2SC1327 (T) ,(U)			SEMICONDUCTORS
H302	HT31327 2B	Transistor, 2SC1327 (T) ,(U)			
H303	HT31327 2A	Transistor, 2SC1327 (S) ,(T)			
H304	HT31327 2A	Transistor, 2SC1327 (S) ,(T)			
P600	YD2850004 ZZ2850004	P. C. Board P. C. Board Assy			
		RESISTORS (All resistors are ±5%, ¼W and carbon type, unless otherwise indicated.)			
R601	RT0510214	1KΩ			
R602	RT0510214	1KΩ			
R603	RT0522414	220KΩ			
R604	RT0522414	220KΩ			
R605	RT0515314	15KΩ			
R606	RT0515314	15KΩ			
R607	RT0556214	5.6KΩ			
R608	RT0556214	5.6KΩ			
R609	RT0518114	180Ω			
R610	RT0518114	180Ω			
R611	RT0522314	22KΩ			
R612	RT0522314	22KΩ			
R613	RT0510314	10KΩ			
R614	RT0510314	10KΩ			
R615	RA0104015	Trimming, 100KΩ B			
R616	RA0104015	Trimming, 100KΩ B			
R617	RT0510414	100KΩ			
R618	RT0510414	100KΩ			
R619	RT0512314	12KΩ			
R620	RT0512314	12KΩ			
R621	RT0510114	100Ω			
R622	RT0510114	100Ω			
R623	RT0515214	1.5KΩ			
R624	RT0515214	1.5KΩ			
R625	RT0527214	2.7KΩ			

REF. DESIG.	MARANTZ PART NO.	DESCRIPTION
R626	RT0527214	2.7K Ω
R627	RA0501009	Trimming, 500 Ω B
R628	RA0501009	Trimming, 500 Ω B
R629	RT0527314	27K Ω
R630	RT0527314	27K Ω
R631	GF0547114	470 Ω
R632	GF0547114	470 Ω
R633	GF0522114	220 Ω
R634	GF0522114	220 Ω
R635	RT0533314	33K Ω
R636	RT0533314	33K Ω
R637	GF0522014	22 Ω
R638	GF0522014	22 Ω
R639	GF0522114	220 Ω
R640	GF0522114	220 Ω
R641	GF0522014	22 Ω
R642	GF0522014	22 Ω
R643	GF0522114	220 Ω
R644	GF0522114	220 Ω
R645	GF0568114	680 Ω
R646	GF0568114	680 Ω
R647	RW1000503	Wire Wound, 0.5 Ω \pm 10% 3W
R648	RW1000503	Wire Wound, 0.5 Ω \pm 10% 3W
R649	RW1000503	Wire Wound, 0.5 Ω \pm 10% 3W
R650	RW1000503	Wire Wound, 0.5 Ω \pm 10% 3W
R651	GF0568114	680 Ω
R652	GF0568114	680 Ω
R653	RC1002212	Solid, 2.2 Ω \pm 10% $\frac{1}{4}$ W
R654	RC1002212	Solid, 2.2 Ω \pm 10% $\frac{1}{4}$ W
R655	RC1022012	Solid, 22 Ω \pm 10% $\frac{1}{4}$ W
R656	RC1022012	Solid, 22 Ω \pm 10% $\frac{1}{4}$ W
R657	RT0582214	8.2K Ω
R658	RT0582214	8.2K Ω
CAPACITORS		
C601	EA1070259	Electroly, 100 μ F 25V
C602	EA1070259	Electroly, 100 μ F 25V
C603	DD1610101	Ceramic, 100PF \pm 10%
C604	DD1610101	Ceramic, 100PF \pm 10%
C605	EM1050251	Electroly, 1 μ F \pm 20% 25V
C606	EM1050251	Electroly, 1 μ F \pm 20% 25V
C607	DD1650001	Ceramic, 50PF \pm 10%
C608	DD1650001	Ceramic, 50PF \pm 10%
C609	EA4760509	Electroly, 47 μ F 50V
C610	EA4760509	Electroly, 47 μ F 50V
C611	EA1060259	Electroly, 10 μ F 25V
C612	EA1060259	Electroly, 10 μ F 25V
C613	DD1650001	Ceramic, 50PF \pm 10%
C614	DD1650001	Ceramic, 50PF \pm 10%
C615	EA1070359	Electroly, 100 μ F 35V
C616	EA1070359	Electroly, 100 μ F 35V
C617	DD1610101	Ceramic, 100PF \pm 10%
C618	DD1610101	Ceramic, 100PF \pm 10%
C619	DD1650001	Ceramic, 50PF \pm 10%
C620	DD1650001	Ceramic, 50PF \pm 10%
C621	DD1650001	Ceramic, 50PF \pm 10%
C622	DD1650001	Ceramic, 50PF \pm 10%
C623	EB2280354	Electroly, 2200 μ F 35V
C624	EB2280354	Electroly, 2200 μ F 35V
C625	DF1710405	Film, 0.1 μ F \pm 20% 50V
C626	DF1710405	Film, 0.1 μ F \pm 20% 50V
C627	EA1070109	Electroly, 100 μ F 10V
C628	EA1070109	Electroly, 100 μ F 10V

REF. DESIG.	MARANTZ PART NO.	DESCRIPTION
C629	EA2260359	Electroly, 22 μ F 35V
C630	EA2260359	Electroly, 22 μ F 35V
MISCELLANEOUS		
J601	YP1000099	Plug
J602	YP1000099	Plug
J603	YP1000099	Plug
J604	YP1000099	Plug
J605	YP1000099	Plug
J606	YP1000099	Plug
J607	YP1000099	Plug
J608	YP1000099	Plug
J609	YP1000099	Plug
J610	YP1000099	Plug
J611	YP1000099	Plug
J612	YP1000099	Plug
J613	YP1000099	Plug
J614	YP1000099	Plug
J615	YP1000099	Plug
J616	YP1000099	Plug
J617	YP1000099	Plug
J618	YP1000099	Plug
J619	YP1000099	Plug
J620	YP1000099	Plug
J621	YP1000099	Plug
J622	YP1000099	Plug
J623	YP1000099	Plug
J624	YP1000099	Plug
COILS		
L601	LL2291512	Choke Coil
L602	LL2291512	Choke Coil
SEMICONDUCTORS		
H601	HT313272A	Transistor, 2SC1327(S)
H602	HT313272A	Transistor, 2SC1327(S)
H603	HT313181R	Transistor, 2SC1318(R)
H604	HT313181R	Transistor, 2SC1318(R)
H605	HH0000912	Thermistor, 22D47
H606	HH0000912	Thermistor, 22D47
H607	HD1000302	Diode, 20A90M
H608	HD1000302	Diode, 20A90M
H609	HD1000302	Diode, 20A90M
H610	HD1000302	Diode, 20A90M
H611	HT308281B	Transistor, 2SC828(Q)
H612	HT308281B	Transistor, 2SC828(Q)
H613	HT105641B	Transistor, 2SA564(Q)
H614	HT105641B	Transistor, 2SA564(Q)
H615	HT313842B	Transistor, 2SC1384(R), (Q)
H616	HT313842B	Transistor, 2SC1384(R), (Q)
H617	HT106842B	Transistor, 2SA684(R), (Q)
H618	HT106842B	Transistor, 2SA684(R), (Q)
MISCELLANEOUS		
1032	285010101	Support
1112	51100205E	B. H. M. Screw
1114	54040202N	Spring Washer
P800	YD2850006	P. C. Board
	ZZ2850006	P. C. Board Assembly
RESISTORS		
R801	GS1030103	Wire Wound, 300 Ω , \pm 10% 3W
R802	GJ1025102	Oxide, 250 Ω \pm 10% 2W
R803	RT0518314	Carbon, 18K Ω \pm 5% $\frac{1}{4}$ W

REF. DESIG.	MARANTZ PART NO.	DESCRIPTION
R804	RT0510414	Carbon, 100K Ω \pm 5% $\frac{1}{4}$ W
R805	RC1056012	Solid, 56 Ω \pm 10% $\frac{1}{4}$ W
R806	RC1010012	Solid, 10 Ω \pm 10% $\frac{1}{4}$ W
R807	RC1056012	Solid, 56 Ω \pm 10% $\frac{1}{4}$ W
CAPACITORS		
C801	DK1810351	Ceramic, 0.01 μ F $\begin{matrix} +100\% \\ -0\% \end{matrix}$ 500V
C802	DK1810351	Ceramic, 0.01 μ F $\begin{matrix} +100\% \\ -0\% \end{matrix}$ 500V
C803	EA3370509	Electroly, 330 μ F 50V
C804	EA3370359	Electroly, 330 μ F 35V
C805	EA2270169	Electroly, 220 μ F 16V
C806	EA1070509	Electroly, 100 μ F 50V
C807	EA1070509	Electroly, 100 μ F 50V
C808	EA4770109	Electroly, 470 μ F 10V
C809	DK1840302	Ceramic, 0.04 μ F $\begin{matrix} +100\% \\ -0\% \end{matrix}$
MISCELLANEOUS		
J801	YP1000099	Plug
J802	YP1000099	Plug
J803	YP1000099	Plug
J804	YP1000099	Plug
J805	YP1000099	Plug
J806	YP1000099	Plug
J807	YP1000099	Plug
J808	YP1000099	Plug
J809	YP1000099	Plug
J810	YP1000099	Plug
J811	YP1000099	Plug
J812	YP1000099	Plug
SEMICONDUCTORS		
H801	HT313841R	Transistor, 2SC1384(R)
H802	HD2002107	Diode, S-1.5-01
H803	HD2002107	Diode, S-1.5-01
H804	HD2002107	Diode, S-1.5-01
H805	HD2002107	Diode, S-1.5-01
H806	HD2000501	Diode, W06B
H807	HD2000501	Diode, W06B
H808	HD2000501	Diode, W06B
H809	HD3002709	Diode, WZ-140 500mW
MISCELLANEOUS		
0404	285016002	Bracket
0405	282711202	Shaft
0406	282711203	Shaft
0408	285020101	Partitioner
0409	285016003	Bracket
0410	285016004	Bracket
0412	285012201	Sticker
0421	257710602	Bearing
0422	141511801	Spacer
0508	285016007	Bracket
0509	173011203	Shaft
0510	257726201	Pulley
0517	282711801	Spacer
0611	51040306A	F. H. M. Screw
0615	51100306A	B. H. M. Screw
0616	51100306A	B. H. M. Screw
0618	51100306A	B. H. M. Screw
0621	51100306A	B. H. M. Screw
0623	51100306A	B. H. M. Screw
0625	51100306A	B. H. M. Screw
0626	51100306A	B. H. M. Screw

REF. DESIG.	MARANTZ PART NO.	DESCRIPTION
0628	51102604A	B. H. M. Screw
S001	SR0805017	Rotary Switch, Function
R001	GT0515212	Resistor, Carbon, 1.5K Ω \pm 5% $\frac{1}{4}$ W
R002	RT0518314	Resistor, Carbon, 18K Ω \pm 5% $\frac{1}{4}$ W
R003	RT0518314	Resistor, Carbon, 18K Ω \pm 5% $\frac{1}{4}$ W
C003	EA4760169	Capacitor, Electroly, 47 μ F 16V
S003	SP0201009	Pushswitch Speaker
S004	SP0201009	Pushswitch Speaker
1030	285010901	Shield
0411	285027101	Holder
J015	YJ0100065	Jack
R009	RS0254004	Resistor Variable, Balance 250K Ω BH
R010	RM0254022	Resistor Variable, Volume 250K Ω B
S002	SP0301001	Pushswitch, Power
M001	IM1104203	DC Meter, Signal Strength
C005	EA1070109	Capacitor, Electroly, 100 μ F 10V
0417	285012003	Insulator
0501	285016009	Bracket
0503	263711203	Shaft
0505	257726201	Pulley
0502	285016008	Bracket
0503	263711203	Shaft
0505	257726201	Pulley
0414	281827101	Holder
0631	51570306B	P. H. Tapt Screw
J004	YJ0800013	Socket
J005	YJ0800013	Socket
J006	YJ0800013	Socket
J007	YJ0800013	Socket
J008	YJ0800013	Socket
M003	IN1008007	Lamp
M004	IN1008007	Lamp
M005	IN1008007	Lamp
M006	IN1008007	Lamp
M007	IN1008007	Lamp
0415	282716003	Bracket
0518	282710701	Sheet
P200	YD2849002 (ZZ 2850102)	P. C. Board, Lamp P. C. Board Assy
MISCELLANEOUS		
M201	IN1006301	Lamp
J201	YP1000099	Plug
J202	YP1000099	Plug
J203	YP1000099	Plug
0413	282727401	Reflector
0619	51570306B	P. H. Tapt Screw
0630	51570305B	P. H. Tapt Screw

REF. DESIG.	MARANTZ PART NO.	DESCRIPTION
P400	YD2850002 ZZ2850002	P. C. Board P. C. Board Assy
		RESISTORS (All resistors are ±5%, ¼W and carbon type, unless otherwise indicated.)
R401	RT0510214	1KΩ
R402	RT0510214	1KΩ
R403	RT0547214	4.7KΩ
R404	RT0547214	4.7KΩ
R405	RT0518314	18KΩ
R406	RT0518314	18KΩ
R407	RT0522414	220KΩ
R408	RT0522414	220KΩ
		CAPACITORS
C401	DF1622305	Film, 0.022μF ±10% 50V
C402	DF1622305	Film, 0.022μF ±10% 50V
C403	DD1620101	Ceramic, 200PF ±10% 50V
C404	DD1620101	Ceramic, 200PF ±10% 50V
		MISCELLANEOUS
S401	SP0204003	Pushswitch Tape/Mono/Loudness Muting
J401	YP1000099	Plug
J402	YP1000099	Plug
J403	YP1000099	Plug
J404	YP1000099	Plug
0418	282705101	Guide
P500	YD2850003 ZZ2850003	P. C. Board P. C. Board Assy
		RESISTORS (All resistors are ±5%, ¼W and carbon type, unless otherwise indicated.)
R501	RT0510214	1KΩ
R502	RT0510214	1KΩ
R503	RT0547414	470KΩ
R504	RT0547414	470KΩ
R505	RT0568314	68KΩ
R506	RT0568314	68KΩ
R507	RT0547114	470Ω
R508	RT0547114	470Ω
R509	RT0512314	12KΩ
R510	RT0512314	12KΩ
R511	RT0512314	12KΩ
R512	RT0512314	12KΩ
R513	RT0527214	2.7KΩ
R514	RT0527214	2.7KΩ
R515	RT0522414	220KΩ
R516	RT0522414	220KΩ
R517	RT0512314	12KΩ
R518	RT0512314	12KΩ
R519	RM0104006	Variable, 100KΩ A
R520	RM0104006	Variable, 100KΩ A
R521	RT0527214	2.7KΩ
		CAPACITORS
C501	EM1050251	Electroly, 1μF ±20% 25V
C502	EM1050251	Electroly, 1μF ±20% 25V
C503	EA4750359	Electroly, 4.7μF 35V

REF. DESIG.	MARANTZ PART NO.	DESCRIPTION
C504	EA4750359	Electroly, 4.7μF 35V
C505	DF1610305	Film 0.01μF ±5% 50V
C506	DF1610305	Film 0.01μF ±5% 50V
C507	DF1610405	Film 0.1μF ±5% 50V
C508	DF1610405	Film 0.1μF ±5% 50V
C509	DF1610205	Film 0.001μF ±5% 50V
C510	DF1610205	Film 0.001μF ±5% 50V
C511	DF1610305	Film 0.01μF ±5% 50V
C512	DF1610305	Film 0.01μF ±5% 50V
C513	EA1070359	Electroly 100μF 35V
		MISCELLANEOUS
J501	YP1000094	Plug
J502	YP1000094	Plug
J503	YP1000094	Plug
J504	YP1000094	Plug
J505	YP1000094	Plug
J506	YP1000094	Plug
H501	HT313272A	Transistor 2SC1327(S) ,(T)
H502	HT313272A	Transistor 2SC1327(S) ,(T)
E	285016040	Bracket Assy
0703	285016001	Bracket
0816	53110403E	Hexagon Nut
0818	54020401E	Flat Washer P
0819	54050400R	T. L. Washer OR
0821	55060307F	T. R. Rivet
0822	54050300R	T. L. Washer OR
0826	51100308S	B. H. M. Screw
0827	53110303E	Hexagon Nut
0829	51100308S	B. H. M. Screw
0830	53110303E	Hexagon Nut
0832	51100308S	B. H. M. Screw
0833	53110303E	Hexagon Nut
J001	YT0104004	Terminal FM/AM Ext Ant
J002	YT0206003	Terminal Phono/Tape/Aux
J003	YT0204003	Terminal Tape In/Out
J009	YL0301021	Terminal Ground
J011	YJ0400018	Jack Outlet
J012	YJ0400018	Jack Outlet
J013	YT0304002	Terminal Speaker
J014	YT0304002	Terminal Speaker
0718	145525903	Bush
J010	YJ0800012	Socket Fuse
F001	FS1020004	Fuse 2A (UL)

REF. DESIG.	MARANTZ PART NO.	DESCRIPTION
G001	BF1040001	Printed Compo. 0.1 μ F/120 Ω
W001	YC0240010	AC Cord
L001	LF1120024	Ant Coil AM
0711	257816005	Bracket
0712	257816006	Bracket
0713	550203041	S. H. Rivet
0714	281927103	Holder
0806	51100308S	B. H. M. Screw
0807	54050300R	T. L. Washer OR
0808	53110303E	Hexagon Nut
0810	51100310S	B. H. M. Screw
0811	53110303E	Hexagon Nut
R004	GT0522512	Resistor 2.2M Ω \pm 5% $\frac{1}{2}$ W
1133	62031650W	Lug
1004	285026701	Heat Sink
1006	285005501	Collar
1009	51100314E	B. H. M. Screw
H001	HT403152A	Transistor 2SD315D,E
H002	HT403152A	Transistor 2SD315D,E
H003	HT403152A	Transistor 2SD315D,E
H004	HT403152A	Transistor 2SD315D,E
P700	YD2850005	P. C. Board
	ZZ2850005	P. C. Board Assy
MISCELLANEOUS		
H701	HV0000212	Varistor
H702	HV0000212	Varistor
1007	285012002	Insulator
C004	EC3080552	Capacitor Electroly, 3000 μ F 55V
C001	DK1710301	Capacitor Ceramic, 0.01 μ F \pm 20%
C002	DK1710301	Capacitor Ceramic, 0.01 μ F \pm 20%
1123	62031650W	Lug
1123	62031650W	Lug
J016	YL0107005	Terminal
R005	RJ1010101	Resistor 100 Ω \pm 10% 1W
R006	RJ1010101	Resistor 100 Ω \pm 10% 1W
R007	RC1047012	Resistor Solid 47 Ω \pm 10% $\frac{1}{2}$ W
R008	RC1047012	Resistor Solid 47 Ω \pm 10% $\frac{1}{2}$ W
0903	282715901	Drum
0904	71101569M	Spring
0915	51650304D	Set Screw H. P.
B	284927340	FlyWheel Assy
0427	257706302	Escutcheon
0429	257727301	Fly Wheel
0431	285011201	Shaft
0432	285011202	Shaft
0607	53110603E	Hexagon Nut
0608	54040602N	Spring Washer
0609	54020601E	Flat Washer P
D	285010340	Pointer Assy
0526	281810301	Pointer
0527	285010301	Pointer
0528	281805301	Cover

REF. DESIG.	MARANTZ PART NO.	DESCRIPTION
M002	IN1008018	Lamp
1033	138200503	Clamper
C	285000640	Dial String Assy
0512	120225801	Hook
0513	72080802A	String
0635	56382540G	Eyelet
A	285006340	Escutcheon Assy
0103	285006301	Escutcheon
0104	282740101	Frame
0105	282715801	Window
0106	281825905	Bush
0107	273125901	Bush
0108	285005301	Cover
0110	285025901	Bush
W002	YW2850001	Wire Material
W003	YX2850001	Wire Material
0121	275905701	Leg
0310	51100410A	B. H. M. Screw
0311	54020401A	Flat Washer P
0312	54040402A	Spring Washer
1026	285010501	Chassis
1027	285016006	Bracket
1028	285016005	Bracket
1031	285010903	Shield
1033	138200503	Clamper
1103	51570408B	P. H. Tapt Screw
1104	54040402N	Spring Washer
1106	53110303E	Hexagon Nut
1107	51570310B	P. H. Tapt Screw
1110	51100306E	B. H. M. Screw
1113	51570306B	P. H. Tapt Screw
1115	51100306E	B. H. M. Screw
1117	51570306B	P. H. Tapt Screw
1118	51570306B	P. H. Tapt Screw
1119	51570310B	P. H. Tapt Screw
1122	51570306B	P. H. Tapt Screw
1124	51100306S	B. H. M. Screw
1125	51570306B	P. H. Tapt Screw
1126	51570306B	P. H. Tapt Screw
1127	54050300R	T. L. Washer OR
1128	59030805P	Washer

REF. DESIG.	MARANTZ PART NO.	DESCRIPTION
1129	51570306B	P. H. Tapt Screw
1130	54050300R	T. L. Washer OR
1131	51570306B	P. H. Tapt Screw
1132	54050300R	T. L. Washer OR
1134	53110303E	Hexagon Nut
1135	54050300R	T. L. Washer
1108	51570306B	P. H. Tapt Screw
L002	TS1760901	Power Transf 120V
0112	281815401	Knob
0114	285015401	Knob
0115	282815402	Knob
0118	282715701	Lid
0119	257711803	Spacer
0120	282825702	Lid
0124	352812001	Insulator
0202	285026501	Indicator
0211	257886100	Label UL Caution
0212	257886102	Label Do not remove cover
0213	257886103	Label See marking on bottom
0214	250626506	Indicator Do not use as handle
0302	51122608E	T. H. M. Scdew
0304	51100406S	B. H. M. Screw
0306	51100406S	B. H. M. Screw
0307	54020401S	Flat Washer P
0424	257710601	Bearing
0425	281810601	Bearing
0521	285030201	Dial
0523	282705302	Cover
0532	282626901	Protector
0603	51640412D	Set Screw C P
0604	54040402N	Spring Washer
0605	53110403E	Hexagon Nut
0613	51100306A	B. H. M. Screw
0614	54050300R	T. L. Washer OR
0634	51100306S	B. H. M. Screw
0635	56382540G	Eyelet
1111	51100306E	B. H. M. Screw





TECHNICAL SPECIFICATIONS

AUDIO CIRCUITS:

Rated continuous (RMS) power output per channel, both channels operating simultaneously	10 Watts at 4 and 8 ohms 8 Watts at 16 ohms
Comparable Total Music Power (IHF)	30 Watts at 8 ohms
High-level hum and noise (ref. 10 Watts at 8 ohms)	-79dB
Phono hum and noise	1.5 μ V equivalent input
Dynamic range (phono input to tape recording output)	96dB
I.M. Distortion (SMPTE), at rated power	1.0%
Distortion decreases as output is lowered	
Total Harmonic Distortion, at rated power	1.0% Maximum
Distortion decreases as output is lowered	
Power Bandwidth (IHF) for 1.0% THD	15 Hz to 50,000 Hz
Damping Factor (ref. 8 ohms)	Greater than 45
Frequency Response	
Through phono	1.0dB
Input Sensitivity (for 10 Watts at 8 ohms)	
High level	150 mV
Phono (1,000 Hz)	2.2 mV
Input Impedance	
High-level	100,000 ohms
Phono	47,000 ohms
Channel Separation 20 Hz to 20,000 Hz	35 dB Minimum



FM SECTIONS:

IHF Usable Sensitivity	3.0 μ V
Selectivity	50 dB
Noise Quieting	-60 dB at 1,000 μ V
Total Harmonic Distortion, 400 Hz, 100% Mod	Mono: 0.2% Stereo: 0.5%
Frequency Response (ref. 75 μ sec. de-emphasis)	\pm 1 dB 50 Hz to 15 KHz
Stereo Separation	1,000 Hz 40 dB
Sub Carrier (38 KHz) Suppression	60 dB

GENERAL:

Power Requirements	120 V AC 50 to 60 Hz
At rated output, both channels operating	95 Watts
Idling Power (Volume Control at zero)	20 Watts
Dimensions	
Panel Width	14-11/64 Inches
Panel Height	4-23/32 Inches
Depth	11-1/32 Inches
Weight	
Unit alone	17.6 lbs
Packed for shipment	30 lbs



* These specifications and exterior designs may be changed for improvement without advance notice.

30 33 40 50 60 70 80 90 100 110 120 130 140 150 160 170 180 190 200 210 220 230 240 250 260 270 280 290 300 310 320 330 340 350 360 370 380 390 400 410 420 430 440 450 460 470 480 490 500 510 520 530 540 550 560 570 580 590 600 610 620 630 640 650 660 670 680 690 700 710 720 730 740 750 760 770 780 790 800 810 820 830 840 850 860 870 880 890 900 910 920 930 940 950 960 970 980 990 1000



marantz

MARANTZ CO., INC. • P.O. BOX 99 • SUN VALLEY, CALIFORNIA • 91352

A WHOLLY-OWNED SUBSIDIARY OF SUPERSCOPE INC., SUN VALLEY, CALIFORNIA 91352