

251



**SERVICE  
MANUAL 2020/2050**



**marantz**

**model 2020/2050**

*Stereophonic Tuner*



**MARANTZ DESIGN AND SERVICE**

Using superior design and selected high grade components, MARANTZ Company has created the ultimate in stereo sound. Only original MARANTZ parts can insure that your MARANTZ product will continue to perform to the specifications for which it is famous.

Parts for your MARANTZ stereo are generally available within 72 hours throughout the nation via a toll-free line to our National Parts Depot in California. The sales professionals who take your call immediately refer to their own desk top computer terminal and can quickly determine the availability and price information you require. If for some reason, your order should exceed our available stock, we usually can instantly provide an alternate replacement part or current delivery information. When the order is placed and confirmed, the computer simultaneously generates "hard copy" orders at the distribution center. As hard copies come directly from the computer to the national parts depot, your requested stock is assembled and prepared for shipment and placed on the first available carrier for delivery to you.

**ORDERING PARTS**

Phone orders will eliminate mail delays, and we encourage the use of this method. If you order by mail, use MARANTZ parts order forms which are available from our National Parts Depot located at the following address:

SUPERSCOPE NATIONAL PARTS DEPARTMENT  
20525 Nordhoff Street  
Chatsworth, California 91311  
Phone: 1-800-423-5108  
1-213-998-9333

The following information must be supplied to eliminate delays in processing your order:

1. Complete address.
2. Complete part numbers.
3. Complete description of parts.
4. Model number for which part is required (indicate MARANTZ).
5. Account number (for account customers only).

Direct consumers will be provided with the current retail price quotation on available parts in order to advise them of the cost of the parts and shipping.

**OVERSEAS PARTS ORDERING**

Parts may also be ordered from the following overseas addresses:

**CANADA**

Superscope Canada, Ltd.  
3710 Nashua Drive  
Mississauga  
Ontario, Canada L4V1M5

**AUSTRALIA**

Superscope (Australasia) Pty., Ltd.  
32 Cross Street (P.O. Box 604)  
Brookvale 2100 N.S.W.  
Australia

**JAPAN**

Marantz Japan, Inc.  
3622 Kamitsuruma  
Sagamihara Shi  
Kanagawa, Japan

**EUROPE**

Superscope Europe, S.A.  
Avenue Leopold III, 2  
7120 Perennes-Lez-Binche  
Belgium

Marantz France  
Rue Louis Armand 9  
92600 Asnieres  
Hauts-de-Seine  
France

Marantz Audio U.K. Ltd.  
London Road, 203  
Staines  
Middlesex  
England

Superscope GmbH  
Max-Planck-Strass 22  
D-6072 Dreieich  
West Germany

All of the above locations are fully equipped to take care of your total service needs. Because various countries have differing configuration requirements, it is necessary that you contact the service facility in your particular country. In the event that there is no service location listed for your country, please contact the nearest facility for the necessary assistance.

## TABLE OF CONTENTS

SECTION	PAGE
1. INTRODUCTION .....	1
2. P.W. BOARDS .....	1
3. TEST EQUIPMENT REQUIRED SERVICING .....	2
4. ALIGNMENT PROCEDURES .....	2
4.1 FM Alignment procedures (Selector switch in the "FM" position) .....	2.3
4.2 Muting Circuit Alignment .....	3
4.3 Multiplex Alignment Procedures (Selector switch in the "FM" position) .....	3
4.4 AM Alignment Procedures (Selector switch in the "AM" position) .....	4
5. VOLTAGE CONVERSION FOR EUROPEAN MODEL .....	5
6. SCHEMATIC DIAGRAMS .....	6
7. DIAGRAM AND COMPONENT LOCATIONS .....	8
7.1 Tuner Assembly (P100) Schematic Diagram and Component Locations .....	8
7.2 Power Supply Assembly (P800) Schematic Diagram and Component Locations .....	8
7.3 Function Led. Assembly (PY00) Schematic Diagram and Component Locations .....	9
7.4 Stereo Led. Assembly (PZ00) Schematic Diagram and Component Locations .....	9
7.5 Switch Assembly (PS00) Schematic Diagram and Component Locations .....	10
8. BLOCK DIAGRAM .....	12
9. EXPLOCED VIEW AND PARTS LIST .....	13
10. ELECTRICAL PARTS LIST .....	19
11. TECHNICAL SPECIFICATIONA .....	22



### 1. INTRODUCTION

This service manual was prepared for use by Authorized Warranty Stations and contains service information for Marantz Model 2020, 2050 AM/FM Stereophonic Tuner. Servicing information and voltage data included in this manual are intended for use by the knowledgeable and experienced technician only. All instructions should be read carefully. No attempt should be made to proceed without a good understanding of the operations in the Tuner.

The parts list furnishes information by which replacement parts may be ordered from the Marantz Company. A simple description is included for parts which can usually be obtained through local suppliers.

### 2. P.W. BOARDS

As can be seen from the circuit diagram, the chassis of Model 2020, 2050 consists of the following units. Each unit mounted on a printed circuit board is described within the square enclosed by a bold dotted line on the circuit diagram.

- 1. Tuner . . . . . mounted on P.W. Board P100
- 2. Power Supply . . . . . mounted on P.W. Board P800
- 3. Switch . . . . . mounted on P.W. Board PS00
- 4. Function Led. . . . . mounted on P.W. Board PY00
- 5. Stereo Led. . . . . mounted on P.W. Board PZ00

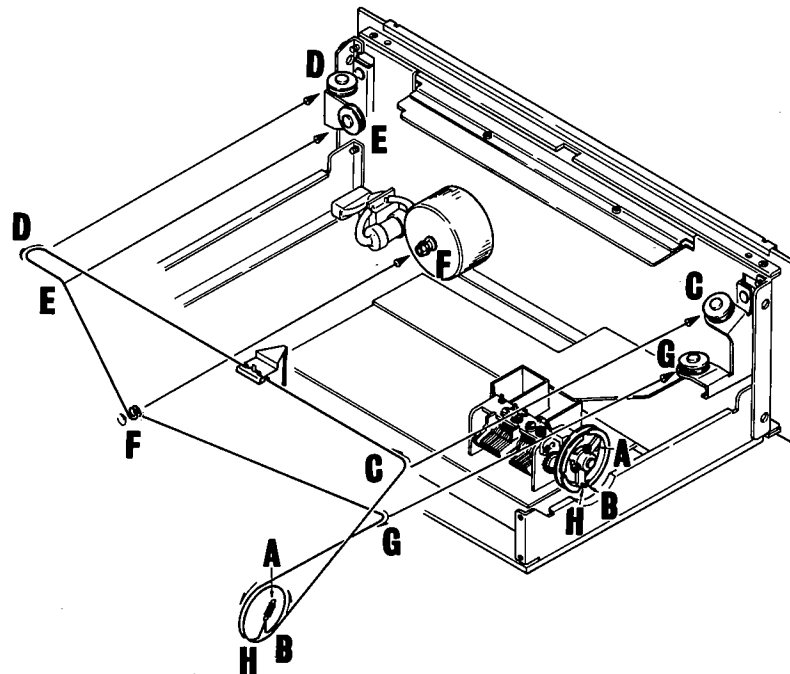

Figure 1. Dial Stringing

### 3. TEST EQUIPMENT REQUIRED FOR SERVICING

This table lists the test equipment required for servicing the Model 2020/2050 Tuner.

Item	Manufacturer and Model No.	Use
AM Signal Generator		Signal source for AM alignment
Test Loop		Use with AM Signal Generator
FM Signal Generator MPX Signal Generator	Sound Technology Model 1000A	Signal source for FM alignment Stereo separation alignment and trouble shooting
Distortion Analyzer Audio Oscillator AC VTVM	Sound Technology Model 1700A	Distortion measurements Sinewave and squarewave signal source Voltage measurements (AC)
Oscilloscope	Tektronix Model T932 Philips Model 3232	Waveform analysis and trouble shooting
Frequency Counter	Fluke Model 1900A	MPX Oscillator adjustment (VCO)
Circuit Tester		Trouble shooting
DC VTVM	Fluke Model 8000 "Digital" Simpson Model 313, Triplet Model 801	Voltage measurements (DC)
AC Wattmeter	Simpson Model 1379	Monitors primary power to tuner
Line Voltmeter	Simpson Model 1359	Monitors potential of primary power to tuner
Variable Autotransformer	Superior Electronic Co., Powerstat Model 116B-10A	Adjusts level of primary power to tuner

### 4. ALIGNMENT PROCEDURES

A dummy resistor of 47 kohms must be connected across the tuner output terminals before alignment.

#### 4.1 FM Alignment procedures (Selector switch in the "FM" position)

##### 1. FM IF Alignment

Step	Signal Source Connection	Signal Frequency	Indicator Connection	Set Dial Pointer to:	Adjust:
1	Sweep generator to point ⓑ through 5pF capacitor	10.7 MHz marker at 10.6, 10.7 and 10.8 MHz	Oscilloscope to point ⓐ	Quiet point on band.	L104 for maximum and symmetric response.
2			Oscilloscope to point ⓓ		L201 for straight and Symmetric "S" curve response.
3	Repeat steps 1 and 2.				

2. FM RF Alignment

Step	Signal Source Connection	Signal Frequency	Indicator Connection	Set Dial Pointer to:	Adjust:
1	RF generator to FM antenna terminals (A) through matching network (300 ohms, balanced) (Maintain RF level below limit.)	87.4 MHz	VTVM to L or R channel output (W002)	87.4 MHz with tuning gang closed.	L103 for maximum output.
2		109 MHz		109 MHz with tuning gang open.	C119 for maximum output.
3		90 MHz		90 MHz	L101, L102 for maximum output.
4		106 MHz		106 MHz	ANT. RF. TRIM. CAP. for maximum output.
5	Repeat steps 1 to 4.				
6	Check overall response curve and repeat above steps as necessary to obtain maximum sensitivity.				
7	No connection	No signal			L201 Primary core (bottom) center tuning meter pointer indicates its center.
8	RF generator 1 mV output to FM antenna terminals (A) through matching network (300 ohms, balanced)	98 MHz	Distortion meter to (D)	98 MHz	L201 Secondary core (upper) for minimum distortion.
9					
10		98 MHz		98 MHz	R232 So that signal Strength meter M001 may read 85%

4.2 Muting Circuit Alignment

Step	Signal Source Connection	Signal Frequency	Indicator Connection	Set Dial Pointer to:	Adjust:
1	RF generator 12.5μV output to FM antenna terminals (A) through matching network (300 ohms, balanced)	98 MHz	VTVM to R or L channel output (W 002)	98 MHz	R233 for 12.5μV threshold level. (During this adjustment turn the muting pushswitch "ON".)

4.3 Multiplex Alignment Procedures (Selector switch in the "FM" position)

Step	Signal Source Connection	Signal Frequency	Indicator Connection	Set Dial Pointer to:	Adjust:
1	RF generator to FM antenna terminals (A) through matching network (300 ohms, balanced), with 1mV FM stereo simulator RF level and 100% modulation (pilot 9%)	No Modulation	Frequency counter to point (E)(J140)	98 MHz	R326 so that Frequency counter may precisely read 19 kHz
2		Stereo, left (1,000 Hz)	VTVM to right channel output (W002, white)		R316 for maximum output and same separation in both channels.
3		Stereo, right (1,000 Hz)	VTVM to left channel output (W 002, Red)		
4	Repeat steps 2 and 3.				

#### 4.4 AM Alignment Procedures (Selector switch in the "AM" position)

##### 1. AM IF Alignment

Step	Signal Source Connection	Signal Frequency	Indicator Connection	Set Dial Pointer to:	Adjust:
1	No connection	No signal	_____	_____	R228 so that signal strength meter M001 may read 0%
2	Sweep generator to point Ⓕ	455 kHz marker	Oscilloscope to point Ⓒ (J141)	Quiet point on band.	L154 for maximum and symmetric response.

##### 2. AM RF Alignment

Step	Signal Source Connection	Signal Frequency	Indicator Connection	Set Dial Pointer to:	Adjust:
1	RF generator to AM antenna terminals through IHF dummy	515 kHz	VTVM to L or R channel output (W002)	515 kHz with tuning gang closed.	L153 for maximum output.
2		1,650 kHz		1,650 kHz with tuning gang open.	OSC. TRIM. CAP. for maximum output.
3		600 kHz		600 kHz	L001 for maximum output.
4		1,400 kHz		1,400 kHz	ANT. TRIM. CAP. for maximum output.
5	Repeat steps 1 to 4 as necessary to obtain maximum sensitivity.				

**5. VOLTAGE CONVERSION**

**• EUROPEAN MODEL ONLY**

The Model 2020, 2050 is equipped with a universal power transformer that may be adjusted to operate at 110 V, 120 V, 220 V, or 240 V AC at 50 to 60 Hz. To convert the unit to a different power source voltage, reposition conversion plug as shown in Figure 2.

**CAUTION**

DISCONNECT POWER SUPPLY CORD FROM AC OUTLET BEFORE CONVERTING VOLTAGE.

**Figure 2. Voltage Conversion Chart**

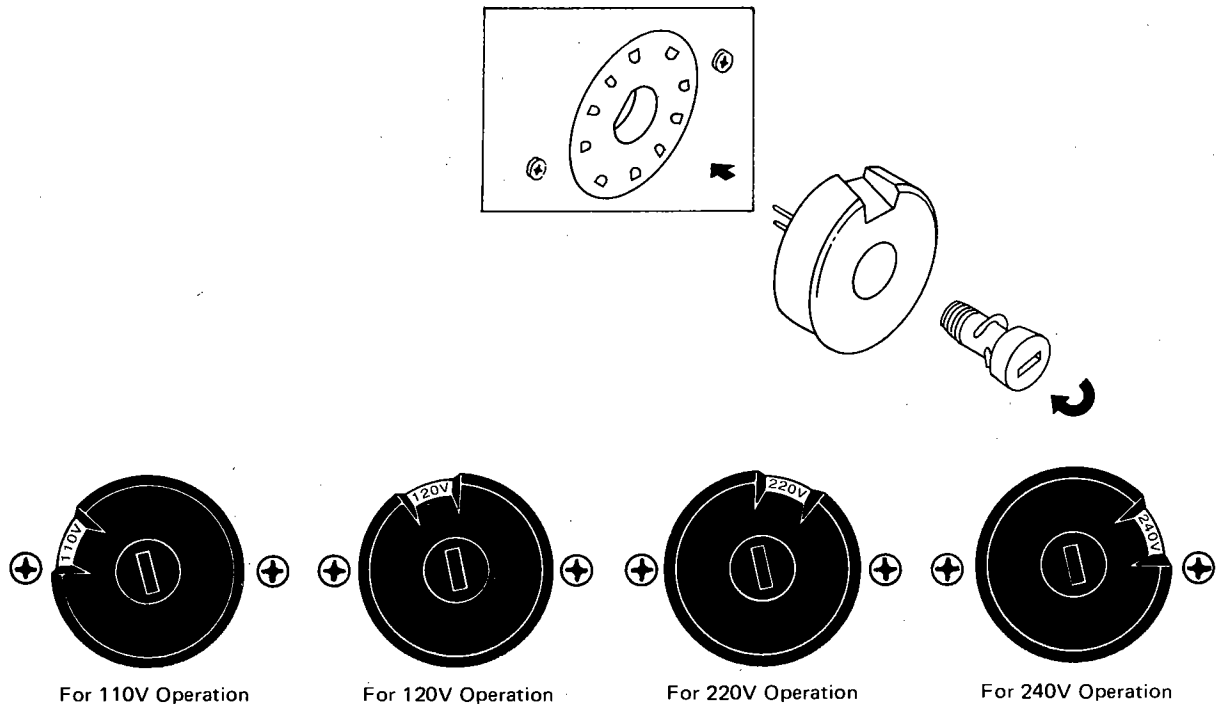

**FTZ REGULATION**

**Instruction for the use in the range other than specified in FTZ codes.**

**Achtung für die Leute, die in dem Gebiet wohnen, wo die FTZ-Bestimmungen vorherrschend sind.**

Sollte des Gerät auch für Frequenzen ausserhalb des in den FTZ-Bestimmungen angegebenen Bereiches empfangsbereit sein, bitten wir, den Bereich durch Nachstellen des Kernes in der Oszillatorspule (in der Abbildung mit "FTZ" gekennzeichnet) so zu korrigieren, dass er den Bestimmungen entspricht.



6. SCHEMATIC DIAGRAMS

Model 2020/2050

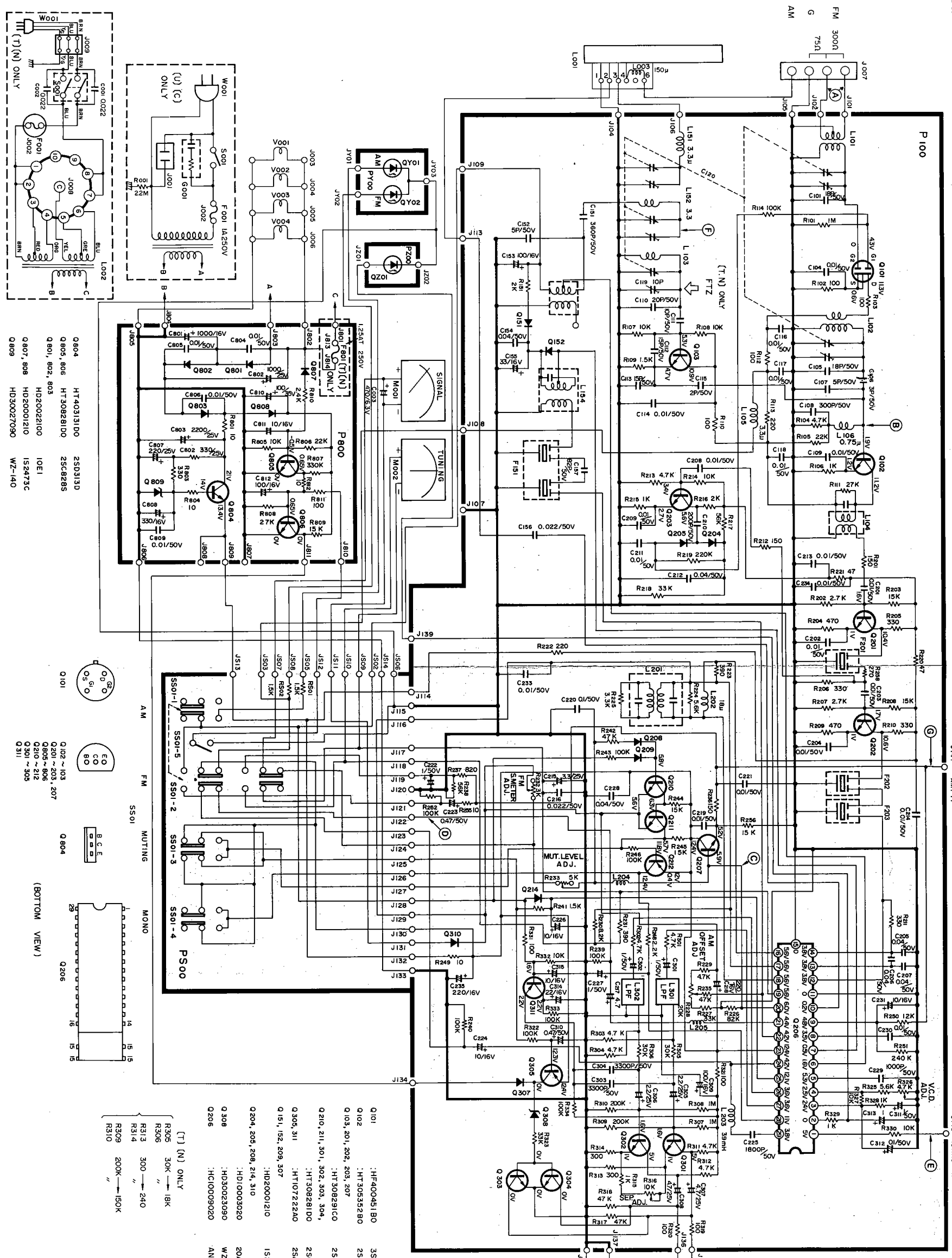

- Q804 HT403131D0 2SD313D
- Q805 806 HT308281D0 2SC8285
- Q801, 802, 803 HD200221C0 10E1
- Q807, 808 HD20001210 1S2473C
- Q809 HD30027090 WZ-140

- Q101
- Q201 ~ 103
- Q201 ~ 203, 207
- Q805 ~ 806
- Q210 ~ 212
- Q301 ~ 305
- Q311

- Q804
- (BOTTOM VIEW)
- Q206

- |                                |             |              |
|--------------------------------|-------------|--------------|
| Q101                           | :HF400451B0 | 3SK45B       |
| Q102                           | :HT30535290 | 2SC5358 OR C |
| Q103, 201, 202                 | :203, 207   | 2SC699C      |
| Q210, 211, 301, 302, 303, 304, | :HT308291C0 | 2SC699C      |
| Q305, 311                      | :HT308281D0 | 2SC8285      |
| Q151, 152, 209, 307            | :HT10722240 | 25A722 SORT  |
| Q204, 205, 208, 214, 310       | :HD20001210 | 1S2473C      |
| Q308                           | :HD10003020 | 20A90M       |
| Q206                           | :HD30023090 | WZ-071       |
|                                | :HC10009020 | ANT7000      |
- (T) (N) ONLY
- |      |      |      |
|------|------|------|
| R305 | 30K  | 18K  |
| R306 | 300  | 240  |
| R313 | 300  | 240  |
| R314 | 300  | 240  |
| R309 | 200K | 150K |
| R310 | 200K | 150K |

7. DIAGRAM AND COMPONENT LOCATIONS

7.1 Tuner Assembly (P100) Schematic Diagram and Component Locations

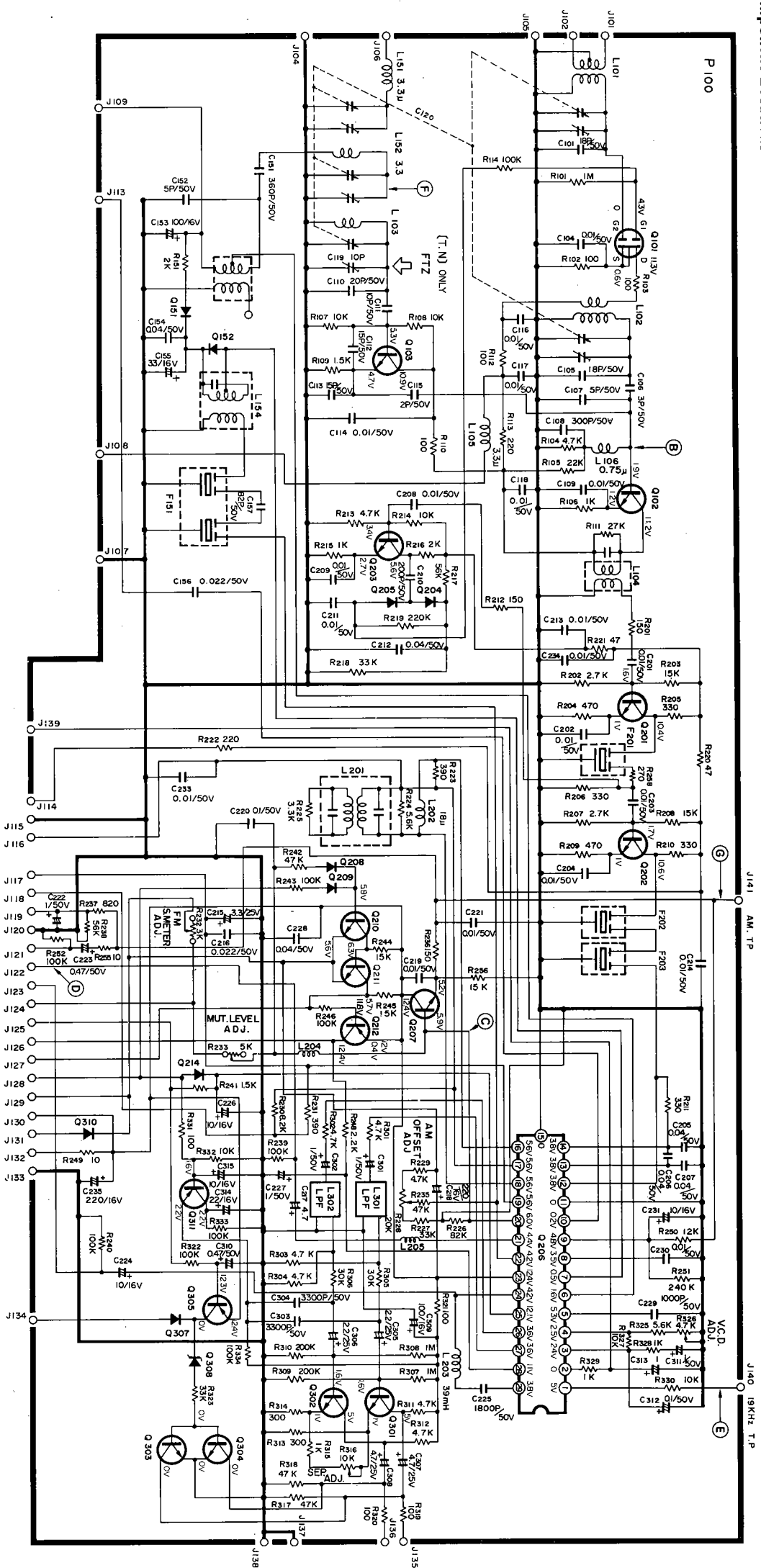

7.2 Power Supply Assembly (P800) Schematic Diagram and Component Locations

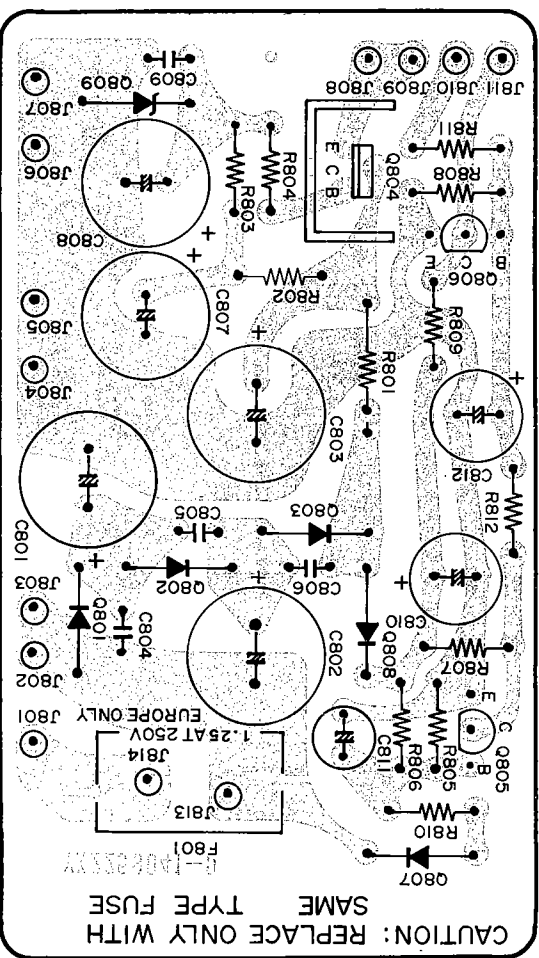
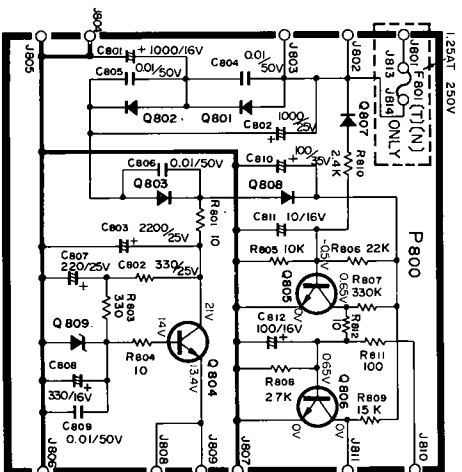

7.3 Function Led. Assembly (PY00) Schematic Diagram and Component Locations

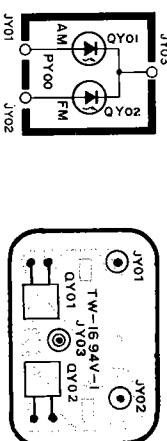

7.4 Stereo Led. Assembly (PZ00) Schematic Diagram and Component Locations

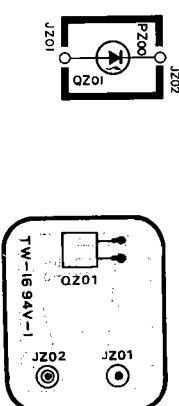

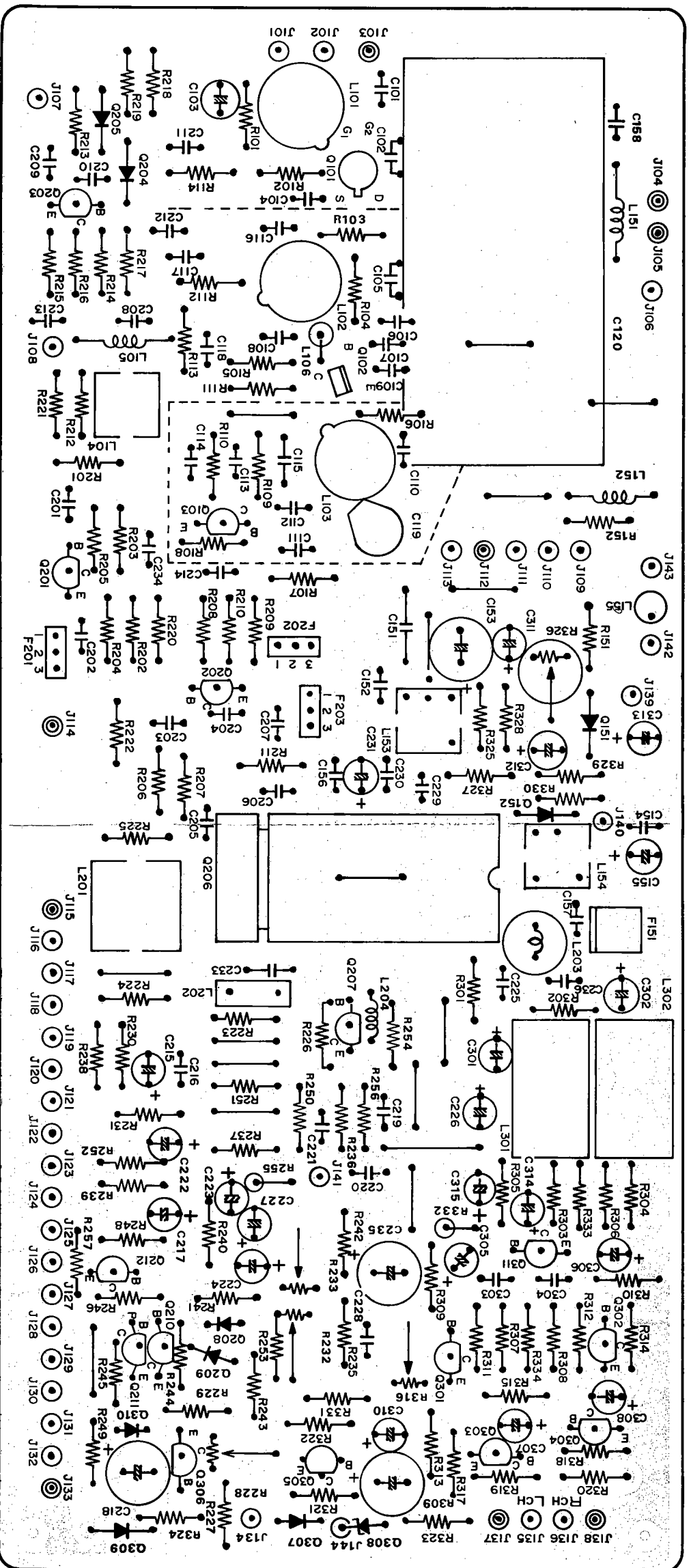

7.5 Switch Assembly (PS00) Schematic Diagram and Component Locations

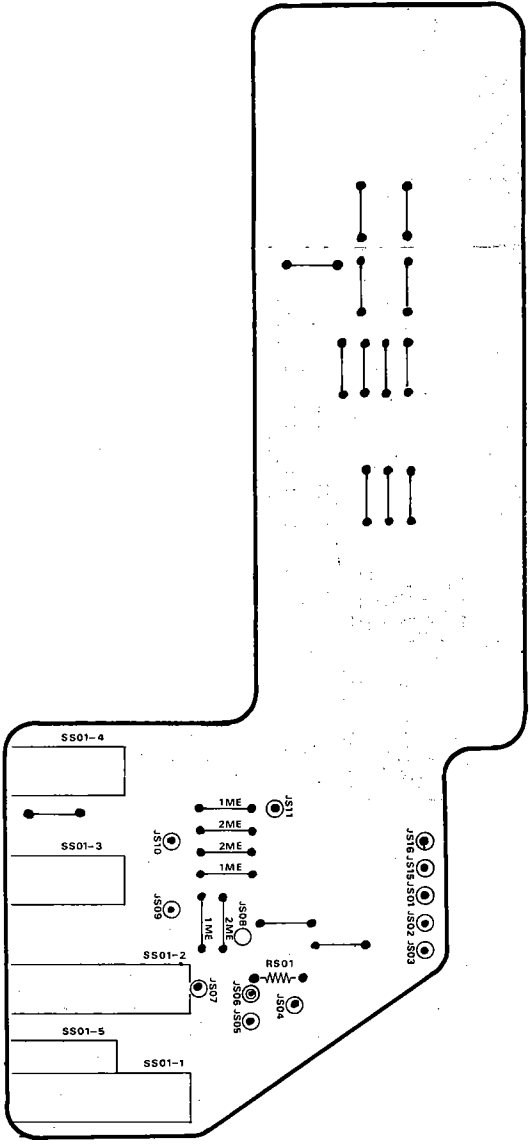
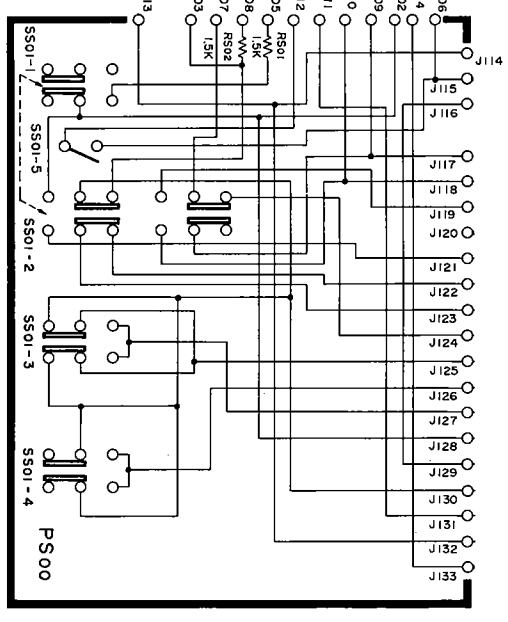

8. BLOCK DIAGRAM

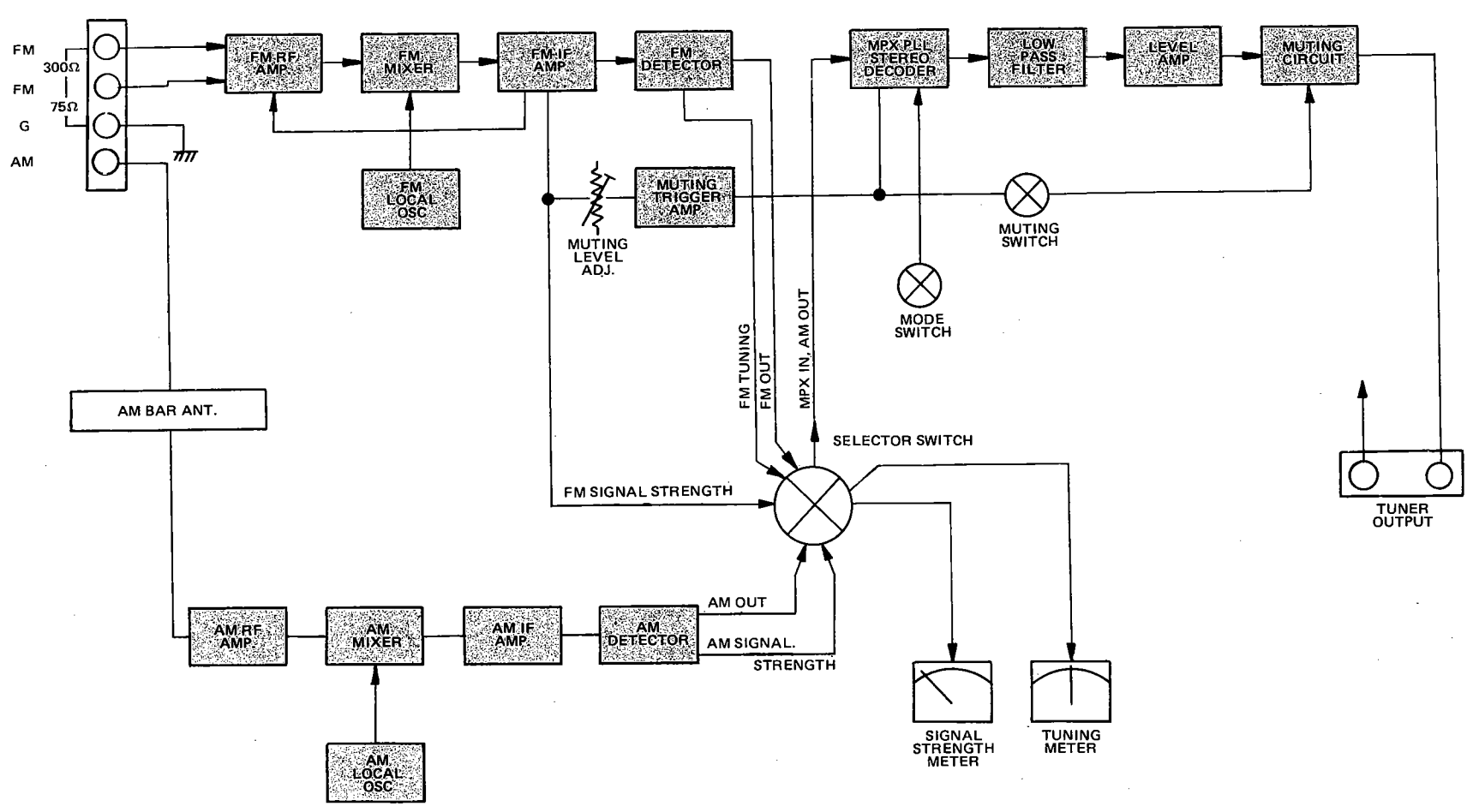

9. EXPLODED VIEW AND PARTS LIST  
● [C01-99] Front Panel

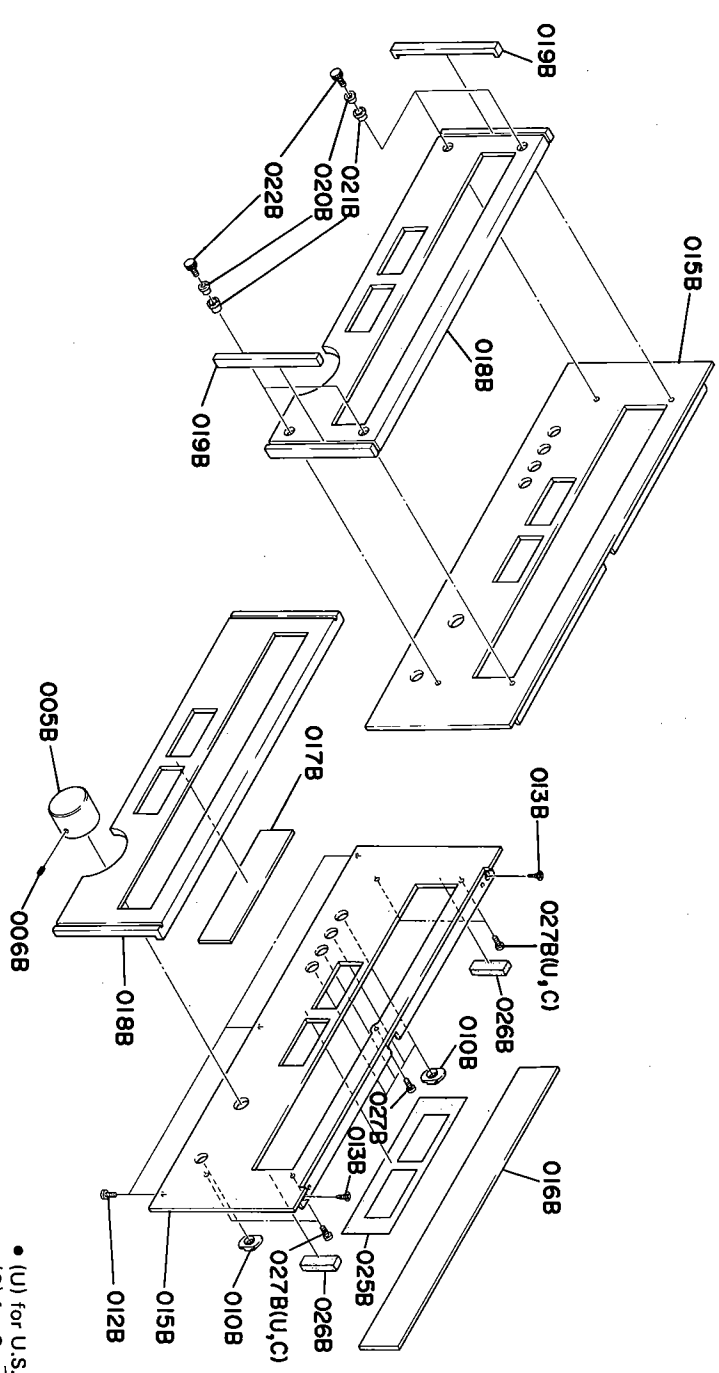

REF. DESIG.	Q'TY			PART NO.	DESCRIPTION
	U	C	N		
A	1	1	1	2259063400	MODEL 2020 (U) Front Panel Assembly, Metal
010B	5	5	5	2978259012	Bushing
015B	1	1	1	2259063110	Escutcheon
016B	1	1	1	2259158010	Window
017B	1	1	1	2259158020	Window
018B	1	1	1	2259063210	Escutcheon, sub.
025B	1	1	1	2259303012	Mask
026B	2	2	2	2259056020	Buffer
027B	5	5	5	51100305A9	B.H.M. Screw B3 x 5
A1	1	1	1	2259063410	MODEL 2020 (N) Front Panel Assembly, Mould
010B	5	5	5	2978259012	Bushing
015B	1	1	1	2259063010	Escutcheon
018B	1	1	1	2259063025	Escutcheon
019B	1	1	1	4214067010	Cap
020B	2	2	2	2470055010	Collar
021B	4	4	4	4214107010	Sheet
022B	4	4	4	52730308S9	H.S. Head Bolt H3 x 8
025B	1	1	1	2259303012	Mask
026B	2	2	2	2259056010	Buffer
A2	1	1	1	2481063400	MODEL 2050 (N) Front Panel Assembly, Metal
010B	5	5	5	2978259012	Bushing
015B	1	1	1	2259063110	Escutcheon
016B	1	1	1	2259158010	Window
017B	1	1	1	2259158020	Window
018B	1	1	1	2481063210	Escutcheon, sub.
025B	1	1	1	2259303012	Mask
026B	2	2	2	2259056020	Buffer
027B	5	5	5	51100305A9	B.H.M. Screw B3 x 5
005B	1	1	1	2279154040	Knob
006B	1	1	1	51690306C9	Socket Screw HP 3 x 6
012B	3	3	3	51280308U0	B.H. TAP, Screw B3 x 8
013B	2	2	2	51340308B0	F.H. TAP, Screw F3 x 6

NOTE:  
Model 2020 ..... (U)(C)(N)  
Model 2050 ..... (N) only

● [C02-99] Lid. (Top cover)

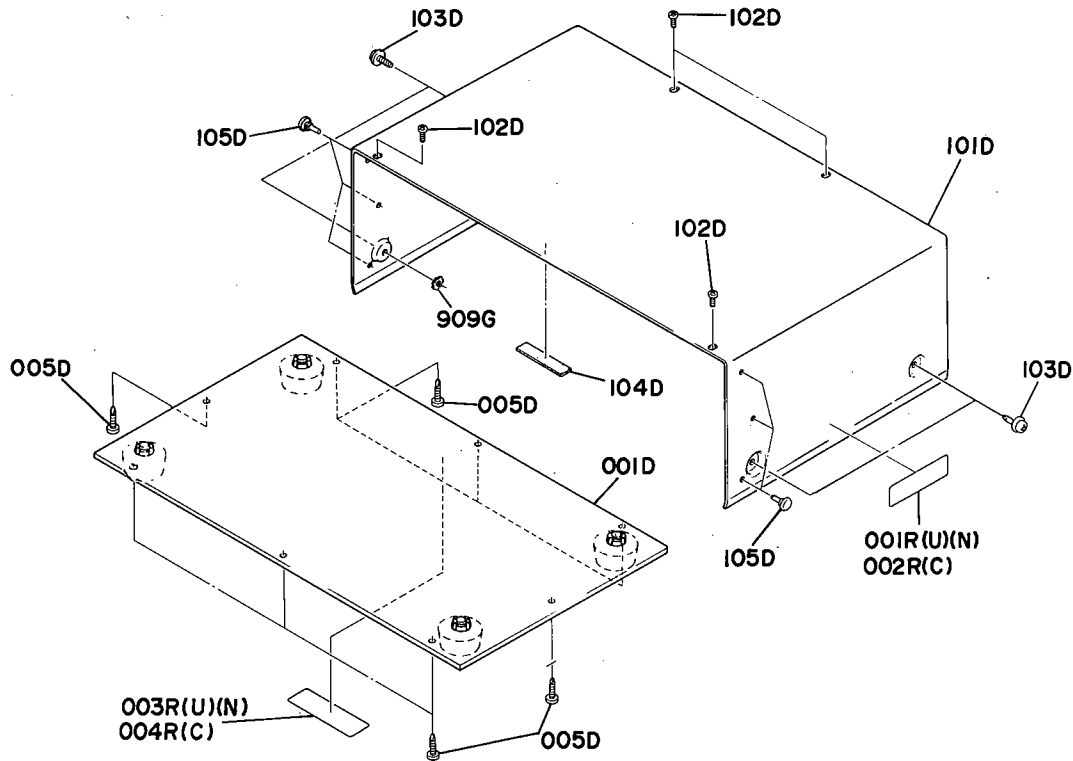

- (U) for U.S.A.
- (C) for Canada
- (N) for Europe

REF. DESIG.	Q'TY			PART NO.	DESCRIPTION
	U	C	N		
001D	1	1	1	2259257500	Lid Assembly
005D	8	8	8	51280410U0	B.H. TAP. Screw B4 x 10

REF. DESIG.	Q'TY			PART NO.	DESCRIPTION
	U	C	N		
101D	1	1	1	2259257010	Lid (Top cover)
102D	4	4	4	51590306S0	B. TAPT. Screw B3 x 6
103D	4	4	4	51260408U0	F. Washer Screw F4 x 8
104D	2	2	2	2965118010	Spacer
105D	6	6	6	2991259010	Bushing
909G			1	54050400R0	T.L. Washer OR
001R	1		1	2932861012	Label
002R		1		2911861143	Label
003R	1		1	2578861010	Label
004R		1		2911861112	Label

● [C03-99] Rear Panel

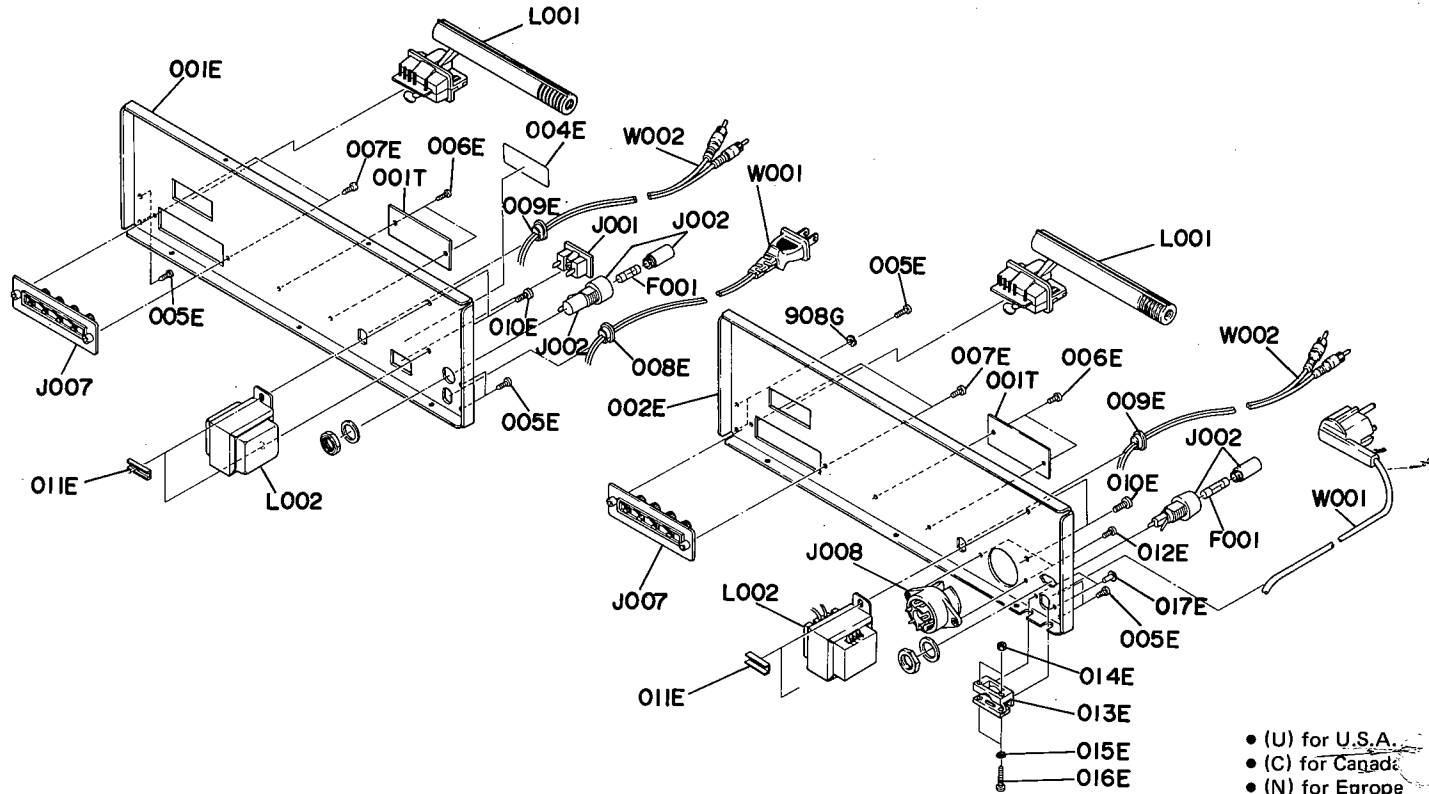

REF. DESIG.	Q'TY			PART NO.	DESCRIPTION
	U	C	N		
B			1	2259160400	Rear Panel Assembly
002E			1	2259160222	Bracket
013E			1	2821259010	Bushing
015E			2	54050300R0	T.R. Rivet
017E			2	55060305S0	T.L. Washer OR
001E	1	1		2259160213	Bracket
004E			1	2911861290	Label
005E	4	4	4	51280306U0	B.H. TAP. Screw B3 x 6
006E	2	2	2	51760306B0	OS TAP. Screw
007E	2	2	2	51280308U0	B.H. TAP. Screw B3 x 8
008E	1	1		1455259030	Bushing
009E	1	1	1	1455259030	Bushing
010E	2	2	2	51100408S9	B.H.M. Screw B4 x 8
011E	2	2	2	2922005010	Clamper
012E			2	51100308S9	B.H.M. Screw B3 x 8
014E			2	53110303A9	Hexagon Nut
016E			2	51060316A9	P.H.M. Screw P3 x 16
908G			1	54050300R0	T.L. Washer OR
001T	1			2259265042	Indicator
001T		1		2259265052	Indicator
001T			1	2259265062	Indicator (Model 2020)
001T			1	2481265010	Indicator (Model 2050)

REF. DESIG.	Q'TY			PART NO.	DESCRIPTION
	U	C	N		
F001			1	FS10050800	Fuse 500mA 250V
F001	1	1		FS10100080	Fuse 1A 250V
J001	1	1		YJ04000560	Jack AC Outlet
J002	1			YJ08000120	Jack Fuse Holder
J002			1	YJ08000220	Jack Fuse Holder
J002			1	YJ08000230	Jack Fuse Holder
J007	1	1	1	YT01040180	Terminal Ant.
J008			1	BY03110010	Plug Voltage Selector
L001	1	1	1	LF11200620	Ant Coil AM Bar Ant.
L002	1	1		TS14808220	Power Transformer
L002			1	TS14808230	Power Transformer
W001			1	YC01900030	A.C. Power Cord
W001	1	1		YC02000150	A.C. Power Cord
W002	1	1	1	YB01000070	Connective Cord

NOTE:  
Model 2020 .... (U)(C)(N)  
Model 2050 .... (N) only

● [P01-99] Front Chassis and General Parts

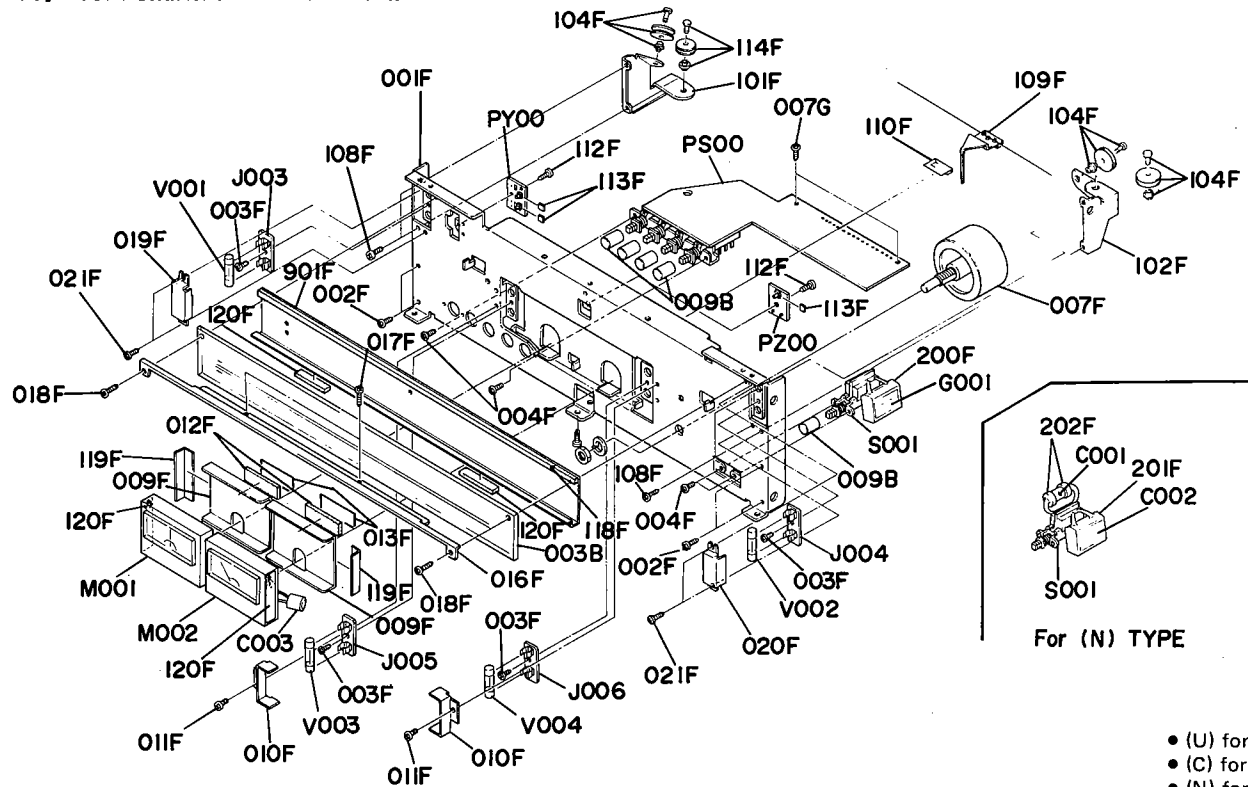

- (U) for U.S.A.
- (C) for Canada
- (N) for Europe

REF. DESIG.	Q'TY			PART NO.	DESCRIPTION
	U	C	N		
001F	1	1	1	2259160012	Bracket
002F	4	4	4	51280306B0	B.H. TAP. Screw B3 x 6
003F	4	4	4	51280306B0	B.H. TAP. Screw B3 x 6
004F	4	4	4	51100306A9	B.H.M. Screw B3 x 6
007F	1	1	1	2259273500	Flywheel
009F	2	2	2	2259274210	Reflector
010F	2	2	2	2259109030	Shield
011F	2	2	2	51280306B0	B.H. TAP. Screw B3 x 6
012F	2	2	2	2481056010	Buffer
013F	2	2	2	2481118010	Spacer
016F	1	1	1	2259271010	Holder
017F	2	2	2	51280306B0	B.H. TAP. Screw B3 x 6
018F	2	2	2	51280310B0	B.H. TAP. Screw B3 x 10
019F	1	1	1	2259109012	Shield
020F	1	1	1	2259109022	Shield
021F	4	4	4	51300306B0	P.H. TAP. Screw P3 x 6
101F	1	1	1	2259160020	Bracket
102F	1	1	1	2259160030	Bracket
104F	3	3	3	2259262510	Pulley
108F	4	4	4	51280306B0	B.H. TAP. Screw B3 x 6
109F	1	1	1	2259103010	Pointer
110F	1	1	1	2259118010	Spacer
112F	2	2	2	51280306B0	B.H. TAP. Screw B3 x 6
113F	3	3	3	2481118020	Spacer
114F	1	1	1	2259262500	Puller
118F	1	1	1	2259107010	Sheet
119F	2	2	2	3956107012	Sheet
120F	2	2	2	2965118010	Spacer
200F	1	1	1	2219120010	Insulator
201F			1	2285120010	Insulator

REF. DESIG.	Q'TY			PART NO.	DESCRIPTION
	U	C	N		
202F			2	3926120010	Insulator
901F			1	2259274010	Reflector
901F	1	1		2259274110	Reflector
C001			1	DF17223800	Film Cap Spark Killer
C002			1	DF17223800	Film Cap Spark Killer
C003	1	1	1	EA47700690	Elect Cap 470µF 6.3V
G001	1			BF10400030	Cap Comp Spark Killer
G001	1	1		DK18103520	Ceramic Cap Spark Killer
J003	1	1	1	YJ08000190	Jack Dial Lamp
J004	1	1	1	YJ08000190	Jack Dial Lamp
J005	1	1	1	YJ08000190	Jack Meter Lamp
J006	1	1	1	YJ08000190	Jack Meter Lamp
M001	1	1	1	IM11055153	D.C. Meter Signal
M002	1	1	1	IM11055143	D.C. Meter Tuning
S001	1	1		SP01010240	Push Switch Power
S001			1	SP02010330	Push Switch Power
V001	1	1	1	IN10080420	Lamp, Dial 8V 0.2A
V002	1	1	1	IN10080420	Lamp, Dial 8V 0.2A
V003	1	1	1	IN10080420	Lamp, Meter 8V 0.2A
V004	1	1	1	IN10080420	Lamp, Meter 8V 0.2A
003B	1	1	1	2259302012	Dial
009B	5	5	5	2259154030	Knob
007G	2	2	2	51280308B0	B.H. TAP. Screw B3 x 8

● [P02-99] Main Chassis, Tuner and Power Supply P.W. Board

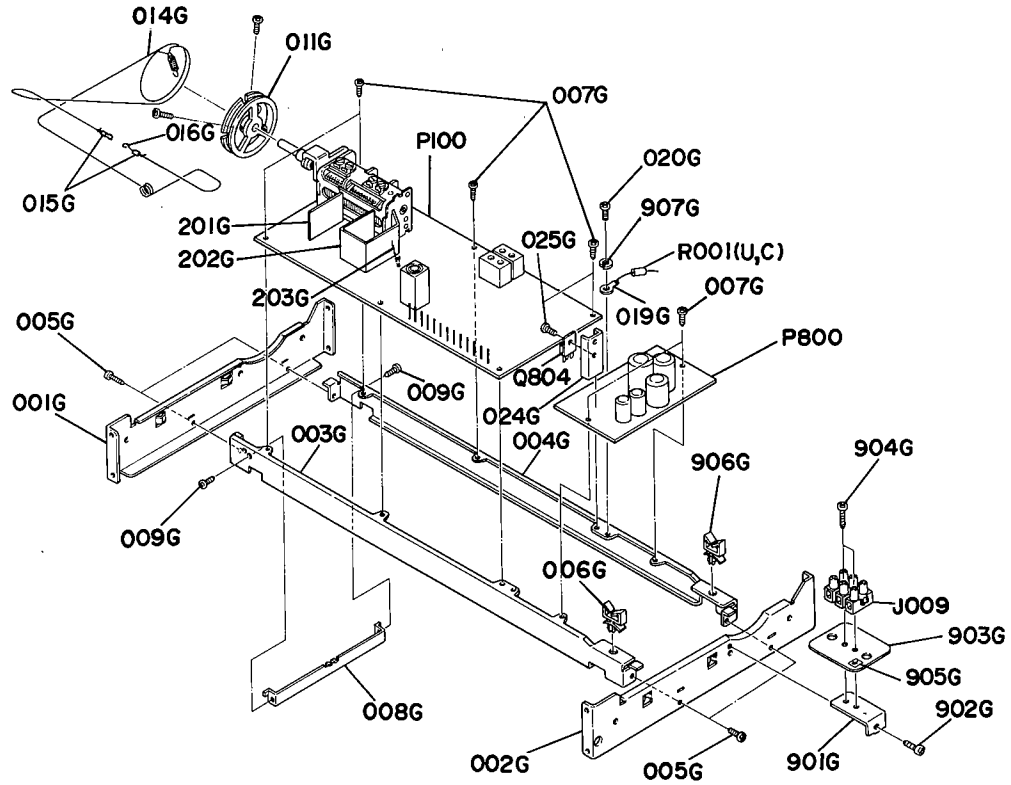

● (U) for U.S.A.  
● (C) for Canad.  
● (N) for Europe

REF. DESIG.	Q'TY			PART NO.	DESCRIPTION
	U	C	N		
C	1	1	1	2259006400	Hook Assembly
014G	1	1	1	72071605A0	String (200)
001G	1	1	1	2259126010	Stay
002G	1	1	1	2259126020	Stay
003G	1	1	1	2259126040	Stay
004G	1	1	1	2259126050	Stay
005G	4	4	4	51280306B0	B.H. TAP. Screw B3 x 6
006G	1	1	1	2886005040	Clamper
007G	6	6	6	51280308B0	B.H. TAP. Screw B3 x 8
008G	1	1	1	2259126063	Stay
009G	2	2	2	51280306B0	B.H. TAP. Screw B3 x 6
011G	1	1	1	2259159010	Drum
019G	1	1	1	62030039W0	Lug
020G	1	1	1	51280306B0	B.H. TAP. Screw B3 x 6
024G	1	1	1	2915267020	Heatsink
025G	1	1	1	51100306A9	B.H.M. Screw B3 x 6
201G	1	1	1	2259109040	Shield
202G	1	1	1	2259109053	Shield
203G	1	1	1	2259109060	Shield

REF. DESIG.	Q'TY			PART NO.	DESCRIPTION
	U	C	N		
901G			1	2991160090	Bracket
902G			1	51280306B0	B.H. TAP. Screw B3 x 6
903G			1	4113120010	Insulator
904G			2	51280314B0	B.H. TAP. Screw B3 x 14
905G			1	2882861020	Label
906G			1	2886005040	Clamper
907G			1	54040302A0	Spring Washer
J009			1	YL09030010	Terminal
R001	1	1		RC10225120	Resistor 2.2MΩ ±10% ½W
P100	1	1	1	YG22590010	P.W. Board. Tuner
	1	1		ZZ22590010	P.W. Board Assembly
			1	ZZ22598010	P.W. Board Assembly
P800	1	1	1	YK22590412	P.W. Board, Power Supply
	1	1		ZZ22590410	P.W. Board Assembly
			1	ZZ22598410	P.W. Board Assembly
Q804	1	1	1	HT403131D0	Transistor 2SD313(D)



● [H01-99] Packing Materials

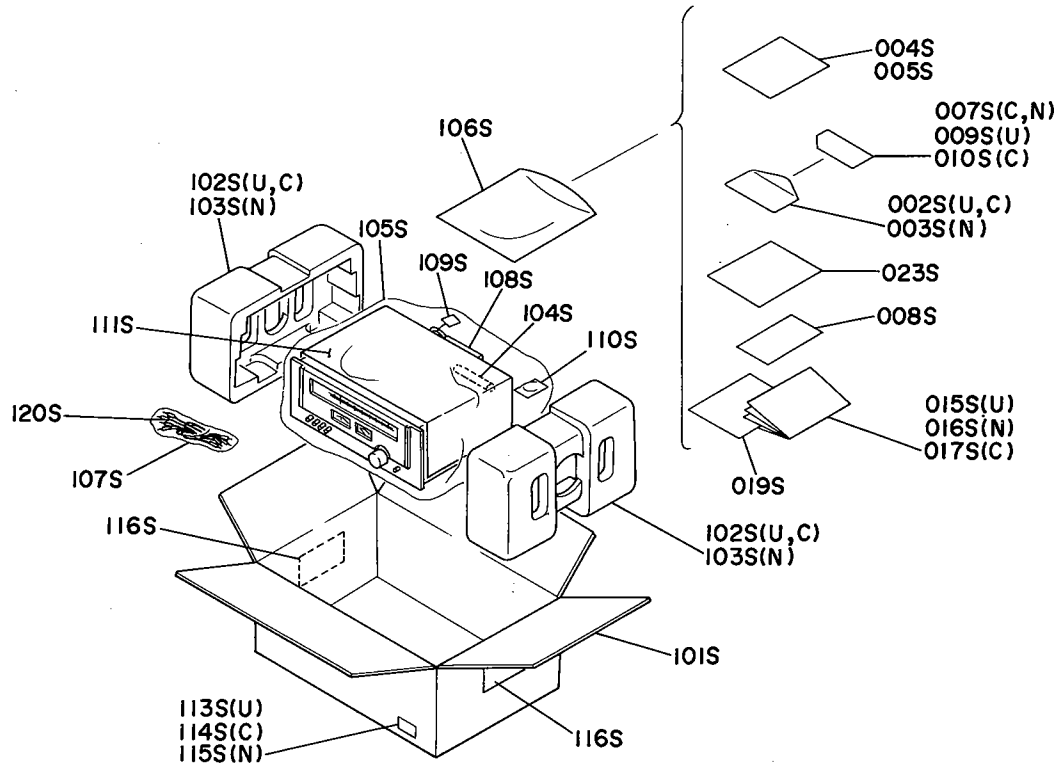

● (U) for U.S.A.  
 ● (C) for Canada  
 ● (N) for Europe

REF. DESIG.	Q'TY			PART NO.	DESCRIPTION
	U	C	N		
002S	1			2225813010	Envelope
002S		1		2918813012	Envelope
003S			1	2818813010	Envelope
005S			1	2818851120	Instruction (Model 2050)
007S	1	1		9630000180	Guarantee Card
008S		1		9650000050	S. Station Card
009S	1			2818854024	Guarantee Card
010S		1		2818854040	Guarantee Card
015S	1			2259851012	Instruction
016S			1	2259851312	Instruction
017S		1		2259851012	Instruction
019S	1	1		2259851020	Instruction
019S			1	2259851030	Instruction
023S		1		2886851100	Instruction
101S	1		1	2259801012	Packing Case (Model 2020)
101S		1		2259801150	Packing Case
101S			1	2481801010	Packing Case (Model 2050)

REF. DESIG.	Q'TY			PART NO.	DESCRIPTION
	U	C	N		
102S	2	2		4214809013	Cushion
103S			2	4214809013	Cushion
104S	1	1	1	2819056010	Buffer
105S	1	1	1	9014335330	Polyethy Bag
106S	1	1	1	9013025010	Polyethy Bag
107S	1	1	1	9011325010	Polyethy Bag
108S	1	1	1	2864804010	Sleeve
109S			1	9560000043	Hang Tag
110S			1	2731821010	Silicagel
111S	1	1	1	2918107160	Sheet
113S		3		9526019010	Serial No. Card
114S			3	9526019020	Serial No. Card
115S			3	9526019060	Serial No. Card (Model 2020)
115S			3	9526019030	Serial No. Card (Model 2050)
116S		2		9510901020	Label
120S	1	1	1	ZA02000070	EXT. Antenna (FM)

NOTE:  
 Model 2020 . . . . (U)(C)(N)  
 Model 2050 . . . . (N) only

• (U) for U.S.A.  
• (C) for Canada  
• (N) for Europe

10. ELECTRICAL PARTS LIST

REF. DESIG.	Q'TY			PART NO.	DESCRIPTION
	U	C	N		
P100	1	1	1	YG22590010	<b>P100-TUNER CIRCUIT BOARD</b>
	1	1		Z222590010	P.W. Board, Tuner
			1	Z222598010	P.W. Board Assembly
					<b>P100-CAPACITORS</b>
C101	1	1	1	DD15180370	Ceramic 18pF ±50%
C104	1	1	1	DK17103300	Ceramic 0.01µF ±20%
C105	1	1	1	DD15180370	Ceramic 18pF ±5%
C106	1	1	1	DD10030370	Ceramic 3pF ±0.5pF
C107	1	1	1	DD10050370	Ceramic 5pF ±0.25pF
C108	1	1	1	DD15301360	Ceramic 300pF ±5%
C109	1	1	1	DK17103300	Ceramic 0.01µF ±20%
C110	1	1	1	DD15200330	Ceramic 20pF ±5%
C111	1	1	1	DD11100300	Ceramic 10pF ±0.5pF
C112	1	1	1	DD15150300	Ceramic 15pF ±5%
C113	1	1	1	DD15150300	Ceramic 15pF ±5%
C114	1	1	1	DK17103300	Ceramic 0.01µF ±20%
C115	1	1	1	DD10020370	Ceramic 2pF ±0.25pF
C116	1	1	1	DK17103300	Ceramic 0.01µF ±20%
C117	1	1	1	DK17103300	Ceramic 0.01µF ±20%
C118	1	1	1	DK17103300	Ceramic 0.01µF ±20%
C119	1	1	1	CT11000080	Trimming 10pF
C120	1	1	1	CA32400090	Variable ALPS C752J
C151	1	1	1	DF55361090	Film 360pF ±5%
C152	1	1	1	DD10050370	Ceramic 5pF ±0.25pF
C153	1	1	1	EA10701690	Elect 100µF 16V
C154	1	1	1	DK18403320	Ceramic 0.04µF +80% -20%
C155	1	1	1	EA33601690	Elect 33µF 16V
C156	1	1	1	DK18223310	Ceramic 0.022µF +80% -20%
C157	1	1	1	DD15820370	Ceramic 82pF ±5%
C201	1	1	1	DK17103300	Ceramic 0.01µF ±20%
C202	1	1	1	DK17103300	Ceramic 0.01µF ±20%
C203	1	1	1	DK17103300	Ceramic 0.01µF ±20%
C204	1	1	1	DK17103300	Ceramic 0.01µF ±20%
C205	1	1	1	DK18403320	Ceramic 0.04µF +80% -20%
C206	1	1	1	DK18403320	Ceramic 0.04µF +80% -20%
C207	1	1	1	DK18403320	Ceramic 0.04µF +80% -20%
C208	1	1	1	DK17103300	Ceramic 0.01µF ±20%
C209	1	1	1	DK17103300	Ceramic 0.01µF ±20%
C210	1	1	1	DD15201360	Ceramic 200pF ±5%
C211	1	1	1	DK17103300	Ceramic 0.01µF ±20%
C212	1	1	1	DK18403320	Ceramic 0.04µF +80% -20%
C213	1	1	1	DK17103300	Ceramic 0.01µF ±20%
C214	1	1	1	DK17103300	Ceramic 0.01µF ±20%
C215	1	1	1	EA33502590	Elect 3.3µF 25V
C216	1	1	1	DK18223310	Ceramic 0.022µF +80% -20%
C217	1	1	1	EA47503590	Elect 4.7µF 35V
C218	1	1	1	EA22701690	Elect 220µF 16V
C219	1	1	1	DK17103300	Ceramic 0.01µF ±20%
C220	1	1	1	DK18104020	Ceramic 0.1µF ±20%
C221	1	1	1	DK17103300	Ceramic 0.01µF ±20%
C222	1	1	1	EA10505090	Elect 1µF 50V
C223	1	1	1	EA47405090	Elect 0.047µF
C224	1	1	1	EA10601690	Elect 10µF 16V
C225	1	1	1	DF15182300	Film 1800pF ±5%

REF. DESIG.	Q'TY			PART NO.	DESCRIPTION
	U	C	N		
C226	1	1	1	EA10601690	Elect 10µF 16V
C227	1	1	1	EA10505090	Elect 1µF 50V
C228	1	1	1	DK18403320	Ceramic 0.047µF +80% -20%
C229	1	1	1	DF55102090	Film 1000pF ±5%
C230	1	1	1	DK17103300	Ceramic 0.01µF ±20%
C231	1	1	1	EA10601690	Elect 10µF 16V
C233	1	1	1	DK17103300	Ceramic 0.01µF ±20%
C234	1	1	1	DK17103300	Ceramic 0.01µF ±20%
C235	1	1	1	EA22701690	Elect 220µF 16V
C301	1	1	1	EE10505050	Elect 1µF 50V
C302	1	1	1	EE10505050	Elect 1µF 50V
C303	1	1	1	DF15332300	Film 0.0033µF ±5%
C304	1	1	1	DF15332300	Film 0.0033µF ±5%
C305	1	1	1	EA22502590	Elect 2.2µF 25V
C306	1	1	1	EA22502590	Elect 2.2µF 25V
C307	1	1	1	EE47502550	Elect 4.7µF 25V
C308	1	1	1	EE47502550	Elect 4.7µF 25V
C309	1	1	1	EA10701690	Elect 100µF 16V
C310	1	1	1	EA47405090	Elect 0.47µF 50V
C311	1	1	1	EE10505050	Elect 1µF 50V
C312	1	1	1	EE10405050	Elect 0.1µF 50V
C313	1	1	1	EE10505050	Elect 1µF 50V
C314	1	1	1	EA22601690	Elect 22µF 16V
C315	1	1	1	EA10601690	Elect 10µF 16V
					<b>P100-RESISTORS</b>
					(All Resistors are ±5% and ¼W)
R101	1	1	1	GD05105140	1MΩ
R102	1	1	1	GD05101140	100Ω
R103	1	1	1	GD05101140	100Ω
R104	1	1	1	GD05472140	4.7KΩ
R105	1	1	1	GD05223140	22KΩ
R106	1	1	1	GD05102140	1KΩ
R107	1	1	1	GD05103140	10KΩ
R108	1	1	1	GD05103140	10KΩ
R109	1	1	1	GD05152140	1.5KΩ
R110	1	1	1	GD05101140	100Ω
R111	1	1	1	GD05273140	27KΩ
R112	1	1	1	GG05101140	100Ω
R113	1	1	1	GD05221140	220Ω
R114	1	1	1	GD05104140	100KΩ
R151	1	1	1	GD05202140	2KΩ
R201	1	1	1	GD05151140	150Ω
R202	1	1	1	GD05272140	2.7KΩ
R203	1	1	1	GD05153140	15KΩ
R204	1	1	1	GD05471140	470Ω
R205	1	1	1	GD05331140	330Ω
R206	1	1	1	GD05331140	330Ω
R207	1	1	1	GD05272140	2.7KΩ
R208	1	1	1	GD05153140	15KΩ
R209	1	1	1	GD05471140	470Ω
R210	1	1	1	GD05331140	330Ω

- (U) for U.S.A.
- (C) for Canada
- (N) for Europe

REF. DESIG.	Q'TY			PART NO.	DESCRIPTION
	U	C	N		
R211	1	1	1	GD05331140	330Ω
R212	1	1	1	GD05151140	150Ω
R213	1	1	1	GD05472140	4.7KΩ
R214	1	1	1	GD05103140	10KΩ
R215	1	1	1	GD05102140	1KΩ
R216	1	1	1	GD05202140	2KΩ
R217	1	1	1	GD05563140	56KΩ
R218	1	1	1	GD05333140	33KΩ
R219	1	1	1	GD05224140	220KΩ
R220	1	1	1	GD05470140	47Ω
R221	1	1	1	GD05470140	47Ω
R222	1	1	1	GD05221140	220Ω
R223	1	1	1	GD05391140	390Ω
R224	1	1	1	GD05562140	5.6KΩ
R225	1	1	1	GD05332140	3.3KΩ
R226	1	1	1	GD05823140	82KΩ
R227	1	1	1	GD05333140	33KΩ
R228	1	1	1	RA05020160	Trimming 5KΩ
R229	1	1	1	GD05103140	10KΩ
R230	1	1	1	GD05822140	8.2KΩ
R231	1	1	1	GD05391140	390Ω
R232	1	1	1	RA03020030	Trimming 3KΩ (B)
R233	1	1	1	RA05020160	Trimming 5KΩ
R235	1	1	1	GD05104140	100KΩ
R236	1	1	1	GD05151140	150Ω
R237	1	1	1	GD05821140	820Ω
R238	1	1	1	GD05563140	56KΩ
R239	1	1	1	GD05104140	100KΩ
R240	1	1	1	GD05104140	100KΩ
R241	1	1	1	GD05152140	1.5KΩ
R242	1	1	1	GD05473140	47KΩ
R243	1	1	1	GD05104140	100KΩ
R244	1	1	1	GD05153140	15KΩ
R245	1	1	1	GD05153140	15KΩ
R246	1	1	1	GD05104140	100KΩ
R248	1	1	1	GD05222140	2.2KΩ
R249	1	1	1	GG05100140	10Ω
R250	1	1	1	GD05123140	12KΩ
R251	1	1	1	GD05244140	240KΩ
R252	1	1	1	GD05104140	100KΩ
R255	1	1	1	GD05100140	10Ω
R256	1	1	1	GD05153140	15KΩ
R258	1	1	1	GD05271140	270KΩ
R301	1	1	1	GD05472140	4.7KΩ
R302	1	1	1	GD05472140	4.7KΩ
R303	1	1	1	GD05472140	4.7KΩ
R304	1	1	1	GD05472140	4.7KΩ
R305	1	1	1	GD05303140	30KΩ
R305	1	1	1	GD05183140	18KΩ
R306	1	1	1	GD05303140	30KΩ

REF. DESIG.	Q'TY			PART NO.	DESCRIPTION
	U	C	N		
R306			1	GD05183140	18KΩ
R307	1	1	1	GD05105140	1MΩ
R308	1	1	1	GD05105140	1MΩ
R309	1	1	1	GD05204140	200KΩ
R310	1	1	1	GD05204140	200KΩ
R311	1	1	1	GD05472140	4.7KΩ
R312	1	1	1	GD05472140	4.7KΩ
R313	1	1	1	GD05301140	300Ω
R313	1	1	1	GD05241140	240Ω
R314	1	1	1	GD05301140	300Ω
R314			1	GD05241140	240Ω
R315	1	1	1	GD05102140	1KΩ
R316	1	1	1	RA01030260	Trimming 10KΩ
R317	1	1	1	GD05473140	47KΩ
R318	1	1	1	GD05473140	47KΩ
R319	1	1	1	GD05101140	100Ω
R320	1	1	1	GD05101140	100Ω
R321	1	1	1	GD05101140	100Ω
R322	1	1	1	GD05104140	100KΩ
R323	1	1	1	GD05333140	33KΩ
R325	1	1	1	GD05562140	5.6KΩ
R326	1	1	1	RA04720050	Trimming 4.7KΩ (B) 0.1W
R327	1	1	1	GD05103140	10KΩ
R328	1	1	1	GD05102140	1KΩ
R329	1	1	1	GD05102140	1KΩ
R330	1	1	1	GD05103140	10KΩ
R331	1	1	1	GD05101140	100Ω
R332	1	1	1	GD05103140	10KΩ
R333	1	1	1	GD05104140	100KΩ
R334	1	1	1	GD05104140	100KΩ
Q101	1	1	1	HF400451B0	F.E.T. 3SK45B
Q102	1	1	1	HT305352B0	Transistor 2SC535B or C
Q103	1	1	1	HT308291C0	Transistor 2SC829C
Q151	1	1	1	HD20001210	Diode 1S2473C
Q152	1	1	1	HD20001210	Diode 1S2473C
Q201	1	1	1	HT308291C0	Transistor 2SC829C
Q202	1	1	1	HT308291C0	Transistor 2SC829C
Q203	1	1	1	HT308291C0	Transistor 2SC829C
Q204	1	1	1	HD10003020	Diode 20A90M
Q205	1	1	1	HD10003020	Diode 20A90M
Q206	1	1	1	HC10009020	IC IC AN7000
Q207	1	1	1	HT308291C0	Transistor 2SC829C
Q208	1	1	1	HD10003020	Diode 20A90M
Q209	1	1	1	HD20001210	Diode 1S2473C
Q210	1	1	1	HT308281D0	Transistor 2SC828S
Q211	1	1	1	HT308281D0	Transistor 2SC828S
Q212	1	1	1	HT107222A0	Transistor 2SA722S or T
Q214	1	1	1	HD10003020	Diode 20A90M
Q301	1	1	1	HT308281D0	Transistor 2SC828S
Q302	1	1	1	HT308281D0	Transistor 2SC828S

• (U) for U.S.A.  
• (C) for Canada  
• (N) for Europe

REF. DESIG.	Q'TY			PART NO.	DESCRIPTION
	U	C	N		
Q303	1	1	1	HT308281D0	Transistor 2SC828S
Q304	1	1	1	HT308281D0	Transistor 2SC828S
Q305	1	1	1	HT107222A0	Transistor 2SA722S or T
Q307	1	1	1	HD20001210	Diode 1S2473C
Q308	1	1	1	HD30023090	Zener WZ071
Q310	1	1	1	HD10003020	Diode 20A90W
Q311	1	1	1	HT107222A0	Transistor 2SA722S or T
<b>P100-FILTERS</b>					
F151	1	1	1	FF10045180	Ceramic AM CF
F201	1	1	1	FF11070050	Ceramic FM CF SFE10.7MDI
F202	1	1	1	FF11070050	Ceramic FM CF SFE10.7MDI
F203	1	1	1	FF11070050	Ceramic FM CF SFE10.7MDI
<b>P100-COILS</b>					
L101	1	1	1	LA12026170	Ant Coil FM
L102	1	1	1	LA12026180	Ant Coil FM
L103	1	1	1	LO12036010	OSC Coil FM
L104	1	1	1	LI10016010	I.F.T. FM
L105	1	1	1	LC13320020	Choke Coil 3.3μH
L106	1	1	1	LC17510010	Choke Coil 0.75μH
L151	1	1	1	LC13320020	Choke Coil 3.3μH
L152	1	1	1	LC13320020	Choke Coil 3.3μH
L153	1	1	1	LO10010530	OSC CouL AM
L154	1	1	1	LI10013200	I.F.T. AM
L201	1	1	1	LI14016240	I.F.T. FM Det
L202	1	1	1	LC11830020	Choke Coil 18μH
L203	1	1	1	LC23960020	Choke Coil 39mH
L204	1	1	1	LC12250030	Choke Coil 2200μH
L205	1	1	1	LC11030020	Choke Coil 10μH
L301	1	1	1	LS20013010	M.P.X. Coil L.P.F
L302	1	1	1	LS20013010	M.P.X. Coil L.P.F
<b>P800-POWER SUPPLY CIRCUIT BOARD</b>					
P800	1	1	1	YK22590410	P.W. Board. Power Supply
	1	1	1	ZZ22590410	P.W. Board Assembly
			1	ZZ22598410	P.W. Board Assembly
<b>P800-CAPACITORS</b>					
C801	1	1	1	EA10801690	Elect 1000μF 16V
C802	1	1	1	EA10802590	Elect 1000μF 25V
C803	1	1	1	EA22802590	Elect 2200μF 25V
C804	1	1	1	DK16103300	Ceramic 0.01μF ±10%
C805	1	1	1	DK16103300	Ceramic 0.01μF ±10%
C806	1	1	1	DK16103300	Ceramic 0.01μF ±10%
C807	1	1	1	EA22702590	Elect 220μF 25V
C808	1	1	1	EA33701690	Elect 330μF 16V
C809	1	1	1	DK17103300	Ceramic 0.01μF ±10%
C810	1	1	1	EA10703590	Elect 100μF 35V
C811	1	1	1	EQ10601610	Elect 10μF 16V
C812	1	1	1	EA10701690	Elect 100μF 16V

REF. DESIG.	Q'TY			PART NO.	DESCRIPTION
	U	C	N		
<b>P800-RESISTORS</b> (All Resistors are ±5% and ¼W)					
R801	1	1	1	GG05100120	10Ω ¼W
R802	1	1	1	GG05331140	330Ω
R803	1	1	1	GD05331140	330Ω
R804	1	1	1	GD05100140	10Ω
R805	1	1	1	GD05103140	10KΩ
R806	1	1	1	GD05223140	22KΩ
R807	1	1	1	GD05334140	330KΩ
R808	1	1	1	GD05273140	27KΩ
R809	1	1	1	GD05153140	15KΩ
R810	1	1	1	GD05242140	2.4KΩ
R811	1	1	1	GD05101140	100Ω
R812	1	1	1	GD05100140	10Ω
<b>P800-SEMICONDUCTORS</b>					
Q801	1	1	1	HD20022100	Diode 10E1
Q802	1	1	1	HD20022100	Diode 10E1
Q803	1	1	1	HD20022100	Diode 10E1
Q804	1	1	1	HT403131D0	Transistor 2SD313D
Q805	1	1	1	HT308281D0	Transistor 2SC828S
Q806	1	1	1	HT308281D0	Transistor 2SC828S
Q807	1	1	1	HD20001210	Diode 1S2473C
Q808	1	1	1	HD20001210	Diode 1S2473C
Q809	1	1	1	HD30027090	Zener WZ140
<b>P800-MISCELLANEOUS</b>					
F801			1	FS10125800	Fuse 1.25AT 250V
J813			1	YJ08000200	Jack Fuse Holder
J814			1	YJ08000200	Jack Fuse Holder
<b>PS00-SWITCH CIRCUIT BOARD</b>					
PS00	1	1	1	YN22592310	P.W. Board, Switch
	1	1	1	ZZ22592310	P.W. Board Assembly
RS01	1	1	1	GD05152140	Resistor 1.5KΩ ±5% ¼W
RS02	1	1	1	GD05152140	Resistor 1.5KΩ ±5% ¼W
SS01	1	1	1	SP04040190	Push Switch
<b>PY00-FUNCTION LED. CIRCUIT BOARD</b>					
PY00	1	1	1	YN22592320	P.W. Board. Function LED.
	1	1	1	ZZ22592320	P.W. Board Assembly
QY01	1	1	1	HI10009020	L.E.D. FM IND.
QY02	1	1	1	HI10009020	L.E.D. AM IND.
<b>PZ00-STEREO LED. CIRCUIT BOARD</b>					
PZ00	1	1	1	YN22592330	P.W. Board. Stereo LED.
	1	1	1	ZZ22592330	P.W. Board Assembly
QZ01	1	1	1	HI10009020	L.E.D. Stereo IND.

(W01-99)	Assembly and Wiring
(T01-99)	Adjustment
(X01-00)	Correction

## 11. TECHNICAL SPECIFICATIONS

### FOR U.S.A. MODEL ONLY

#### AM/FM TUNER SECTION

Sensitivity		
IHF Usable (Mono)	.....	10.3 dBf (1.8 $\mu$ V)
IHF 50 dB Quieting		
Mono	.....	13.2 dBf (2.5 $\mu$ V)
Stereo	.....	37.7 dBf (42 $\mu$ V)
Distortion, Mono and (Stereo) at 65 dBf		
1000 Hz	.....	0.15% (0.3%)
Hum and Noise at 65 dBf (1000 $\mu$ V)		
Mono	.....	72 dB
Capture Ratio at 65 dBf (1000 $\mu$ V)	.....	1.0 dB
Alternate Channel Selectivity	.....	65 dB
Spurious Response Rejection	.....	90 dB
Image Response Rejection	.....	50 dB
IF Rejection (Balanced)	.....	90 dB
AM Suppression	.....	50 dB
Stereo Separation 1000 Hz	.....	45 dB
AM Usable Sensitivity (IHF)	.....	20 $\mu$ V
AM Distortion (THD) at 30% Modulation	.....	1.0%
AM Signal-to-Noise Ratio	.....	50 dB

#### GENERAL

Power Requirements	.....	120 V AC, 60 Hz
Power Consumption at rated output, both channels operating	.....	13 W
Dimensions		
Panel Width	.....	416 mm (16-3/8 inches)
Panel Height	.....	146 mm ( 5-3/4 inches)
Depth	.....	240 mm (9-7/16 inches)
Weight		
Unit alone	.....	5.0 kg (11 lbs)
Packed for Shipment	.....	6.0 kg (13.2 lbs)

### FOR EUROPEAN MODEL ONLY

#### FM TUNER SECTION

Frequency Range	.....	87.5 ~ 108 MHz
Usable Sensitivity 40 kHz Deviation, 98 MHz		
Mono	S/N 26 dB	..... 1.5 $\mu$ V
Stereo	S/N 46 dB	..... 48 $\mu$ V
Alternate Channel Selectivity 98 MHz, $\pm$ 300 kHz	.....	60 dB
Image Response Rejection, 98 MHz	.....	55 dB
IF Rejection, 98 MHz	.....	90 dB
Spurious Response Rejection, 98 MHz	.....	100 dB
AM Suppression, 98 MHz	.....	55 dB
Signal-to-Noise Ratio, 98 MHz		
Un-weighted	Mono	..... 70 dB
	Stereo	..... 65 dB
Weighted	Mono	..... 69 dB
	Stereo	..... 63 dB

**Pilot Signal & Subcarrier Rejection**

19 kHz .....	65 dB
38 kHz .....	68 dB
<b>Total Harmonic Distortion at 98 MHz</b>	
Mono .....	0.1%
Stereo .....	0.2%
<b>Frequency Response</b>	
30 Hz ~ 15 kHz .....	-1.0 dB, +0 dB
<b>Separation</b>	
250 Hz ~ 6.3 kHz .....	43 dB
6.3 kHz ~ 12.5 kHz .....	39 dB
Channel Balance .....	0.2 dB
Output Voltage, 1 kHz .....	750 mV
Output Impedance, 1 kHz .....	4.3 k ohms
Acceptable Load Impedance, 1 kHz .....	47 k ohms
<b>Antenna Terminals</b>	
Balanced .....	300 ohms
Unbalanced .....	75 ohms

**AM TUNER SECTION**

Frequency Range .....	525 ~ 1630 kHz
Usable Sensitivity 26 dB S/N 30% Mod., 1 MHz .....	25 $\mu$ V
Selectivity 1 MHz, $\pm$ 9 kHz .....	46 dB
Image Rejection, 1 MHz .....	50 dB
IF Rejection, 1 MHz .....	45 dB
Spurious Response Rejection, 1 MHz .....	37 dB
Signal-to-Noise Ratio, 1 MHz .....	50 dB
Frequency Response 1 MHz, $\pm$ 3 dB .....	32 Hz ~ 2.1 kHz
Total Harmonic Distortion, 1 MHz .....	1.0%

**GENERAL**

Power Requirements .....	220 V ~, 50 Hz
(E and N versions are featuring an external voltage selector for use on 110/120/240 V. Other versions can be converted by a qualified technician to operate on 110/120/240 V.)	
Power Consumption .....	13 W
<b>Semiconductor Complement</b>	
Integrated Circuits .....	1
Transistors .....	18
Diodes .....	16
Field Effect Transistors .....	1
<b>Dimensions</b>	
Panel Width .....	416 mm (16-3/8")
Panel Height .....	146 mm ( 5-3/4")
Depth .....	240 mm (9-7/16")
<b>Weight</b>	
Unit Alone .....	5.0 kg ( 11 lbs)
Packed for Shipment .....	6.0 kg (13.2 lbs)

**Note**



**marantz.**

**MARANTZ CO., INC. · P.O. BOX 577 · CHATSWORTH, CALIFORNIA · 91311**



A WHOLLY-OWNED SUBSIDIARY OF SUPERSCOPE INC., CHATSWORTH, CALIFORNIA · 91311