

22
5

service
manual

22



marantz

model twenty two

Stereo Receiver



TABLE OF CONTENTS

	PAGE
Introduction	1
Service Notes	1
AM Tuner	1
FM Tuner	2
FM and AM Tuner Alignment	4
Power Amplifier	7
Speaker Protector Relay Circuit	9
Regulated Power Source Alignment	9
Center Tuning Meter Null Alignment	9
Test Equipment for Servicing	10
Part List	16

LIST OF ILLUSTRATIONS

FIGURE		PAGE
1	Main Chassis Component Locations Top View	10
2	Main Chassis Component Locations Bottom View	10
3	Rear Terminal Component Locations	10
4	Dial Stringing Diagram	10
5	FM Front End Assembly P100 Component Locations	11
6	AM Front End Assembly P200 Component Locations	11
7	PHONO Amplifier Assembly P300 Component Locations	11
8	Tone and Pre Amplifier Assembly P400 Component Locations	11
9	AM-FM IF and FM-MPX Demodulator Assembly P500 Component Locations	12
10	Main Amplifier Assembly P600 Component Locations	12
11	DC Amplifier and FM Audio Amplifier Assembly P700 Component Locations	13
12	Regulated Power Supply Unit Assembly P800 Component Locations	13
13	Hi Blend, Low Filter, Hi Filter and Loudness Switches Unit Assembly P900 Component Locations	13
14	Tape Monitor and Mono in L.R. Switches Unit Assembly P920 Component Locations	13
15	Tone Control Unit Assembly P940 Component Locations	14
16	Temperature Compensation Unit Assembly P960 Component Locations	14
17	Speaker Protector Circuit Assembly P980 Component Locations	14
18	Schematic Diagram	15

marantz

model number	bulletin number	date
22R	102R-1	June 2, 1971
for serial numbers	subject	to
	Model 22 Revisions	

Below, we have compiled a list of circuit changes incorporated in the Model 22R as opposed to the unrevised 22. Please note that serial numbers: 11001 to 11599 and, 6626 up, constitute the "R" units.

P100 - F.M. Tuner P.C. Board : (P/N YD 25780130)

R 106 Changed from 2.7 K to 1.2 K
C 108 Changed from 0.6 pF to 0.8 pF
C 118 Changed from 20 pF to 15 pF
C 119 New design, trimmer capacitor P/N CT 10500010
C 131 Added in parallel to C 119, 2 pF ceramic
L 104 New design, Oscillator Coil, P/N LO 12026020
W 101 Wire materials revised, color code

P 200 - A.M. Front End P.C. Board : (P/N YD 25780020)

No Changes

P 300 - Phono Amp. P.C. Board : (P/N YD 25770030)

R 307, 308 Changed from 330 ohms to 2 K $\frac{1}{2}$ W
R 305, 306 Changed from 330 K to 1 M $\frac{1}{2}$ W
R 309, 310 Changed from 330 K to 1.8 M
R 311, 312 Changed from 27 K to 150 K
R 320, 321 Changed from 470 ohms to 560 ohms
R 316, 317 Changed from 10 K to 15 K
C 304, 305 Changed from .01 uF to 1800 pF
R 322 Changed from 47 ohms to 220 ohms
C 310, 311 Changed to 1 uF @ 35 WVDC
C 312 Changed to 100 uF @ 50 WVDC
C 316, 317 Changed from .0027 uF to 500 pF

P 400 - Tone Amp. P.C. Board : (P/N 25770040)

W 401 Wire materials revised, color code

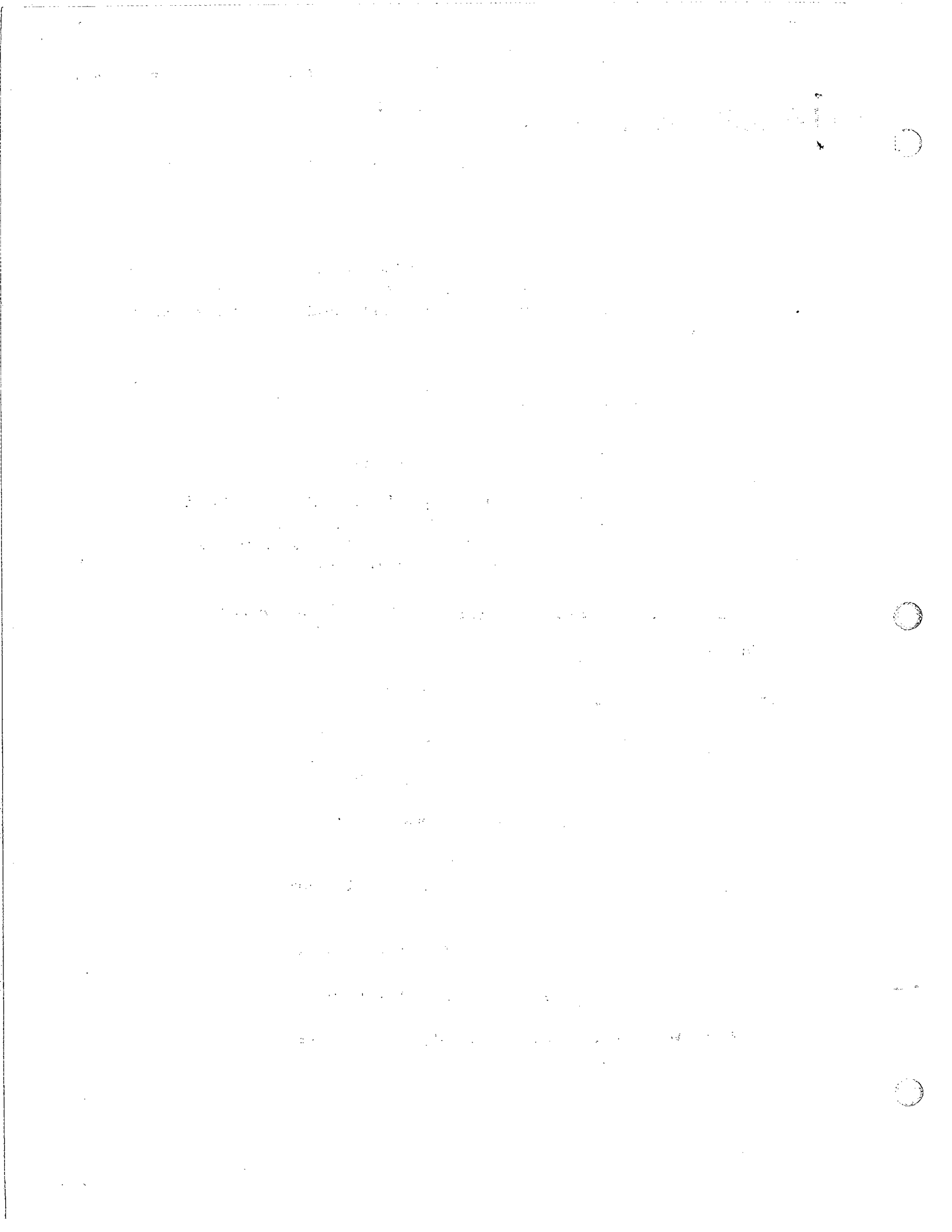

marantz

model number 22R	bulletin number M22R-1	date June 2, 1971
for serial numbers	to	
subject see text		
Model 22 Revisions		

P 500 - AM/FM I.F. and F.M./MPX Demodulator P.C. Board :
(P/N YD 25780050)

C 552 Added, J 520 to GND, 100 uF @ 6.3 VDC
 R 542 Changed from 100 K to 56 K
 R 568 Added, in series from C 519 to H 504 (B), 10 K $\frac{1}{2}$ W
 C 566 Changed from Polyester to Film type capacitor
 C 573, 574 Eliminated
 L 512, 513 and
 L 514, 515 MPX Coil, new type, P/N LS 10010070
 R 514 Changed from 330 K to 5.6 K
 W 501 Wire materials revised, color code

P 600 - Main Amp. P.C. Board : (P/N YD 25780060)

R 617, 618 Changed from 10 K to 9.1 K, $\frac{1}{2}$ W

P 700 - Meter and Stereo Amp. P.C. Board :

Completely redesigned, (new P/N YD 25780140) Meter section
 R 723 Changed from 1.2 K to 5.6 K on Stereo Amp. section
 R 724 Eliminated
 W 701 Wire materials redesigned, color code

P 800 - Power Supply P.C. Board : (P/N YD 25780150)

R 802 relocated between R 804 and H 802 (E) and
 changed from 47 ohms to 10 ohms
 R 807 Added, in series from J 802 to junction C 802, R 804
 and R 802, new Diode IS 1665 (P/N HD 20001100)
 C 804 Changed from 470 uF 35 V. to 330 uF @ 50 WVDC
 C 807 Added, in parallel with R 810, 10 uF @ 35 WVDC
 electrolytic, pos. to GND
 H 801 Transistor, changed from 2SC496 to 2SD234 (HT402343A0)
 H 802 Transistor, changed from 2SC496 to 2SC696 (HT306965A0)
 W 801 Wire materials revised, color code

+B Supply Voltages changed to:

<u>Test Point</u>	<u>Model 22</u>	<u>Model 22 R</u>
8A	+ 34.5 VDC	+ 36.0 VDC
8B	+ 34.5 VDC	33.0 VAC
8E	+ 12.0 VDC	+ 12.0 VDC
8F	+ 27.0 VDC	+ 35.0 VDC

-2-

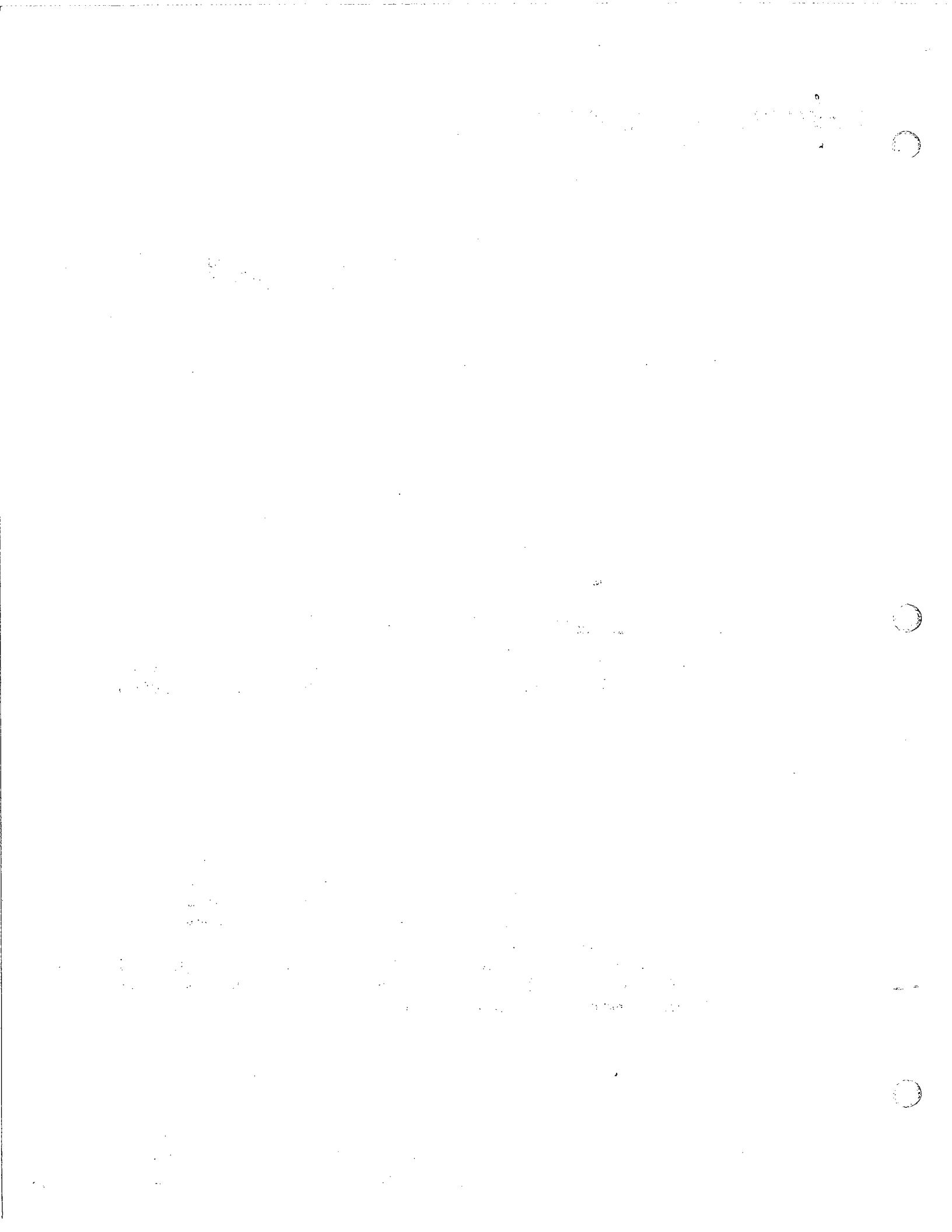

marantz

model number	bulletin number	date
22R	M22R-1	June 2, 1971
for serial numbers	to	
subject	see text	
Model 22 Revisions		

P 900 - Switch P.C. Board : (P/N YD 25780090)

No Changes

P 920 - Switch P.C. Board : (P/N YD 25780030)

W 921 Wire materials revised, color code

P 940 - Tone Control P.C. Board : (P/N YD 25780100)

No Changes

P 980 - Speaker Protector P.C. Board : (P/N YD 25780112)

Completely redesigned (refer to new schematic)

H 984, 985 Diodes, eliminated

J 983 Test Point, + 36 VDC

Miscellaneous Parts, not Board Mounted :

H 006 Bridge Rectifier, new type M 9235 A (P/N HD20005050)

R 018 Changed from 1.2 K to 1.8 K $\frac{1}{2}$ W

C 008, 009 Changed to Film type capacitor

C 015 Changed from 25 V to 50 WVDC rating

Headphone Jack, new P/N YJ 01000650

Socket, for meter lamp, new P/N YJ 02000480

Meter, AM/FM strength, new design P/N IM 11036040

Meter, FM center tuning, new design P/N IM 11036050

W 002, 003 Wire materials revised, color code

F 001 Circuit breaker, new, 4 Amp. P/N FR 10400010

L 006 Power Transformer, new, P/N TS 60501040 (for UL, USA)

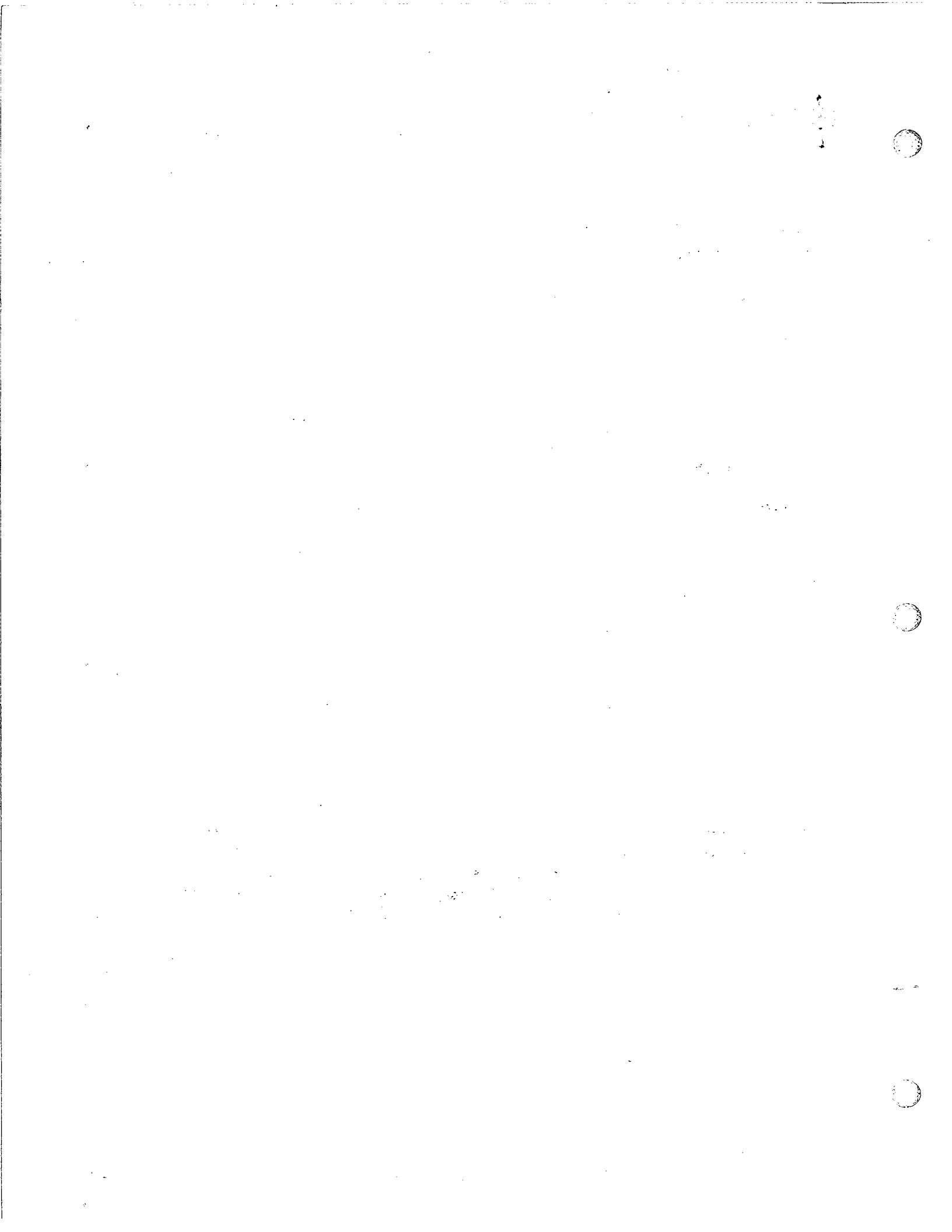

marantz®



22m

22M

HIGH EFFICIENCY 3-WAY SPEAKER SYSTEM

Service Data

22M SPECIFICATIONS...

SPEAKER COMPLEMENT:

1 – 8" Woofer, 1 – 2 1/2" Tweeter

FREQUENCY RESPONSE:

60 Hz – 18 kHz \pm 3 dB

CROSSOVER POINTS:

1.5 kHz, 5 kHz

NOMINAL IMPEDANCE:

8 ohms

POWER HANDLING CAPABILITY:

To be used with amplifiers rated up to 50 Watts *
providing clipping occurs less than 10% of the time.

DIMENSIONS:

58.7 (H) X 31.8 (W) X 20.6 (D) cm
23 1/8 (H) X 12 1/2 (W) X 8 1/8 (D) inches

WEIGHT:

6.1 Kg (13.5 lbs.) unpacked (per unit)
8.8 Kg (19.5 lbs.) packed for shipment

*CAUTION: Even lower powered amplifiers driven into clipping may damage the loudspeaker.

SCHEMATIC

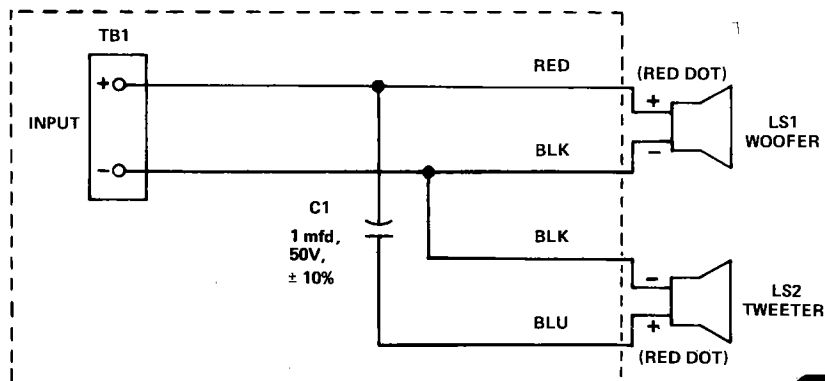

22M PARTS...

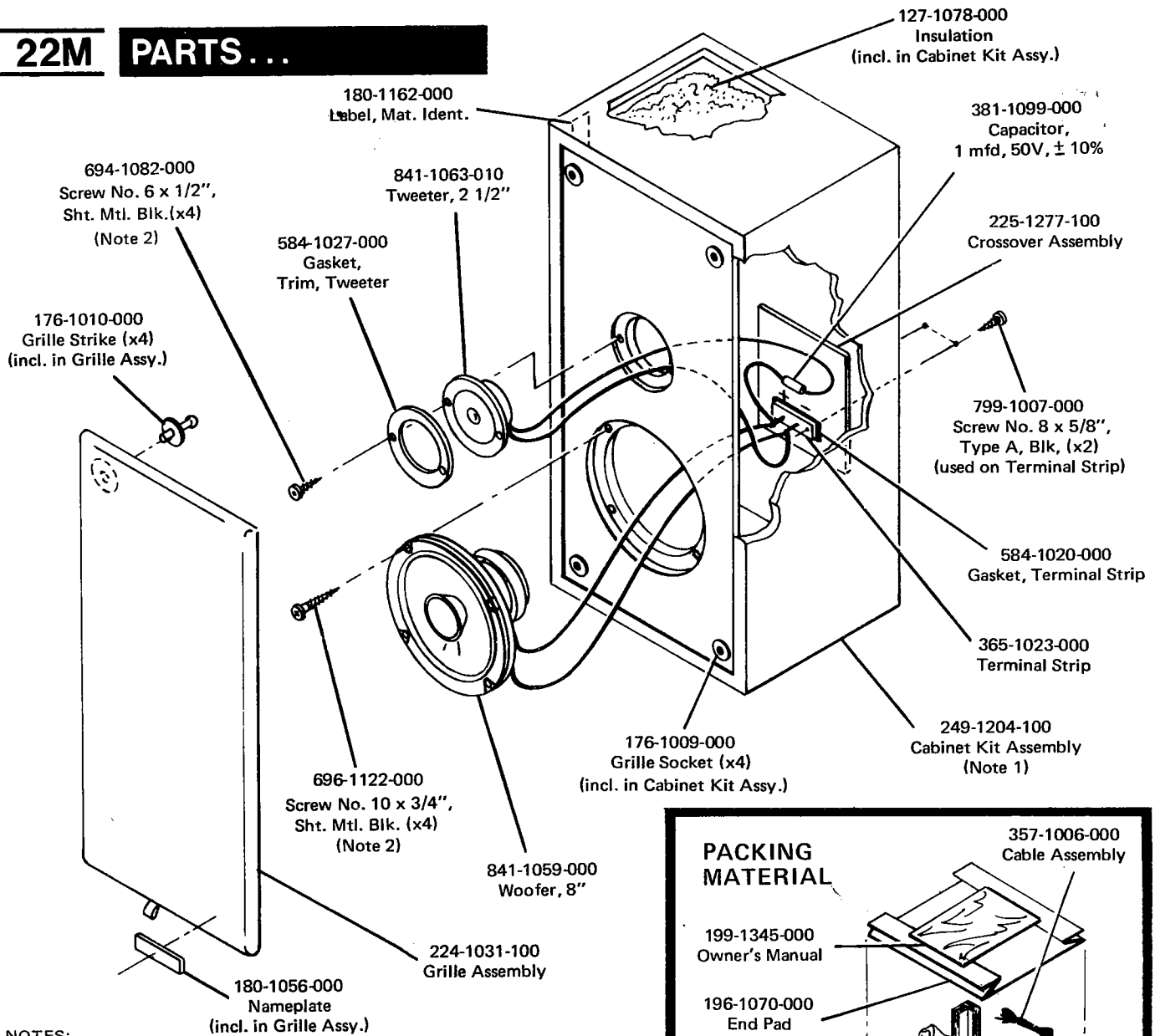

NOTES:

1. Replacement Cabinet Kit Assembly consists of speaker cabinet, insulation, shipping carton and packing material. Speakers, grille, crossover assembly and cable assembly not included.

If the speaker cabinet is being replaced because of freight damage, it should be noted that such damage is not covered under warranty and all such claims be made with the freight carrier involved.

2. 694-1082-000 Sht. Mtl. Blk Screws replace 799-1009-000 Sht. Mtl. Type A 696-1122-000 Sht. Mtl. Blk Screws replace 799-1013-000 Sht. Mtl.

3. Replacement parts may be ordered from the Marantz Parts Department, 20525 Nordhoff Street, Chatsworth, CA 91311. Items such as screws and other hardware may be obtained locally, using the description provided in the above exploded view.

When ordering replacement parts, specify model number, part number and description.

If ordering by telephone, dial: 1-800-423-5108 (Our toll-free number)
1-213-998-9333 (For California or Direct)
ask for National Parts Department.

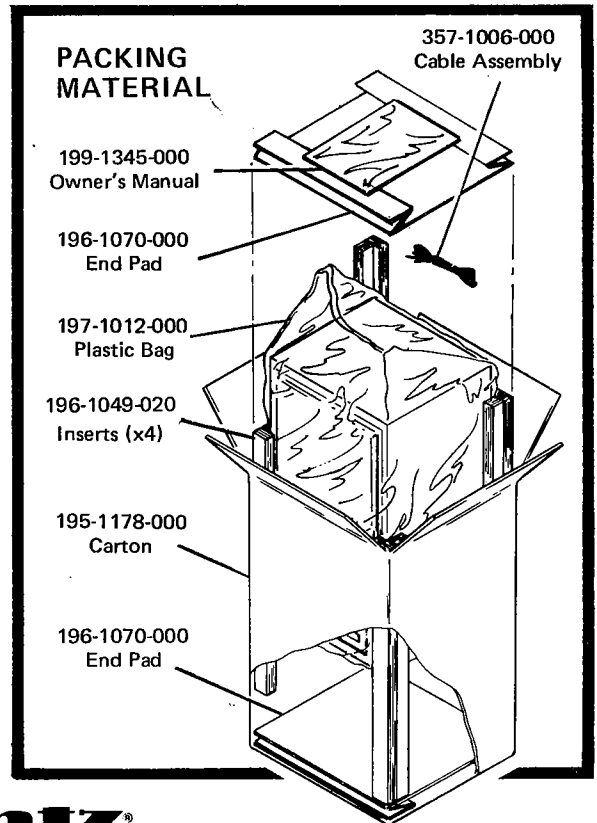

marantz®

MARANTZ CO., INC. 20525 NORDHOFF STREET, CHATSWORTH, CALIFORNIA 91311

A WHOLLY OWNED SUBSIDIARY OF SUPERSCOPE INC., CHATSWORTH, CALIFORNIA 91311

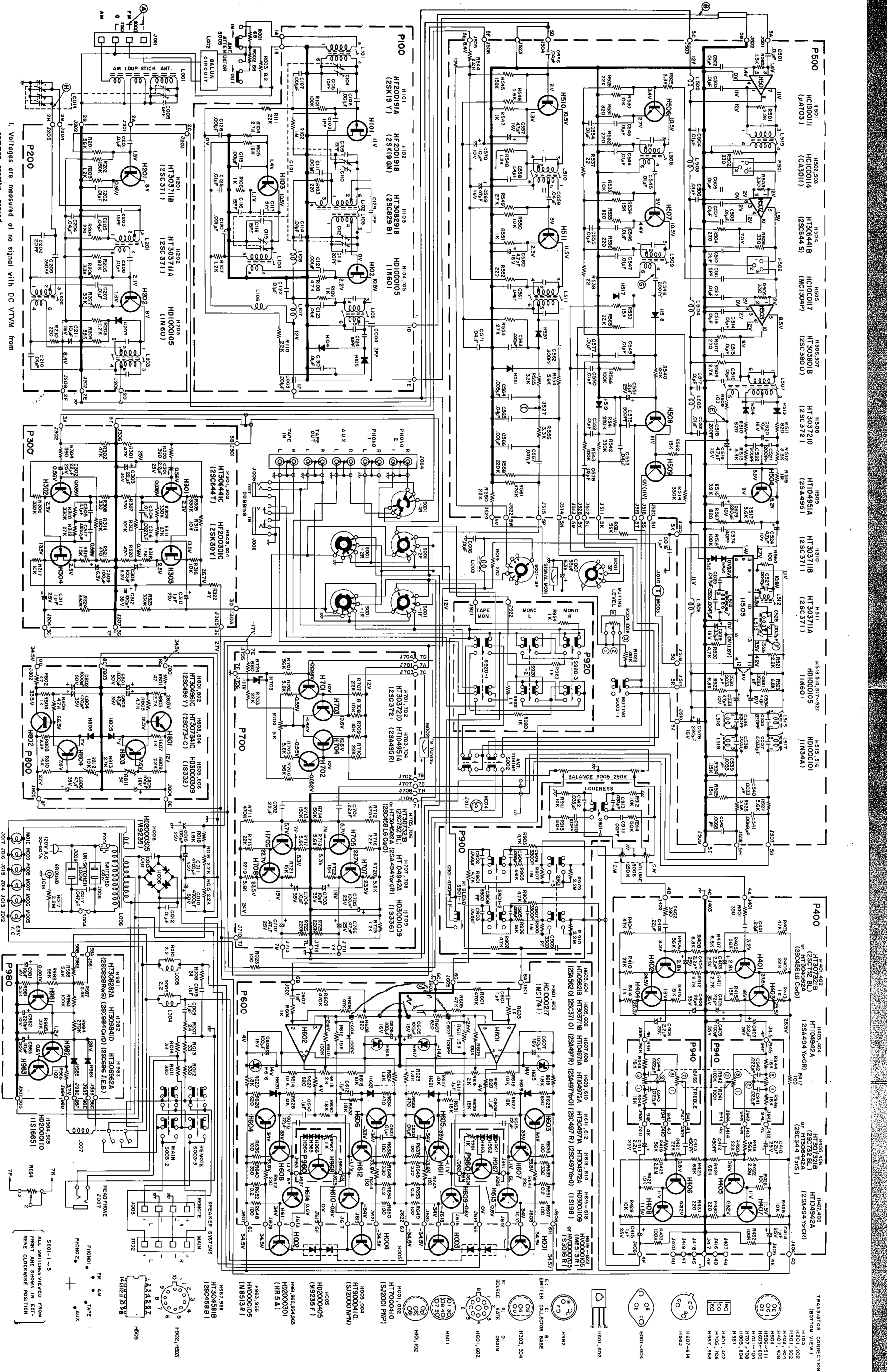

Figure 18 Schematic Diagram

NOTE :

PARTS LIST

REF. DESIG.	MARANTZ PART NO.	DESCRIPTION	REF. DESIG.	MARANTZ PART NO.	DESCRIPTION
A001	257806301-3	Escutcheon	A530	257715402-0	Power Knob
A002	257800301-0	Punched Plate	A533	257705301-2	MPX Lamp Cover
A003	257825701-2	Lid	B001	257825702-2	Lid
A004	257826701-0	Heat-Sink	B003	257810550-2	Main Chassis K
A005	257810301-2	Pointer	B004	257810501-2	Chassis
A006	257826501-2	Indicator	B005	257816001-2	Bracket
A008	257806701-0	Selector Knob Cap	B006	257816001-2	Bracket
A009	257806701-0	Balance Knob Cap	B007	257816002-0	Bracket
A010	257806701-0	Volume Knob Cap	B008	257816002-0	Bracket
A011	257806702-0	Bass Knob Cap	B009	257816002-0	Bracket
A012	257806702-0	Treble Knob Cap	B010	257816002-0	Bracket
A013	257806703-0	Bass Knob Cap	B011	257816009-0	Bracket
A014	257806703-0	Treble Knob Cap	B012	257816050-3	Front Bracket K
A016	257706702-2	Tape Mon. Cap	B013	257816003-2	Bracket
A017	257706702-2	Mono L. Cap	B014	257810101-0	Support
A018	257706702-2	Mono R. Cap	B015	257810101-0	Support
A019	257706702-2	Hi Blend Cap	B016	257810101-0	Support
A020	257706702-2	Low Filter Cap	B018	257816051-2	Tuner Block Bracket K
A021	257706702-2	Hi Filter Cap	B019	257816004-2	Bracket
A022	257706702-2	Loudness Cap	B020	257811201-0	Shaft
A023	257706702-2	Muting Off Cap	B022	257816052-2	AM Antenna Bracket K
A024	257706702-2	Speaker Main Cap	B023	257816005-2	Bracket
A025	257706702-2	Speaker Rem. Cap	B024	257816006-2	Bracket
A026	257706702-2	Power Cap	B025	550203041-0	S.H.Rivet
A028	257706302-2	Escutcheon	B026	550203041-0	S.H.Rivet
A029	257727301-0	Fly-Wheel	B028	257816053-0	Pulley Bracket K
A030	257706303-2	Escutcheon	B029	257816007-0	Bracket
A501	257840101-2	Frame	B030	257711202-0	Shaft
A502	257830201-0	Dial	B031	257711202-0	Shaft
A503	257810701-2	Sheet	B041	257816054-0	Pulley Bracket K
A504	257815401-0	Selector Knob	B042	257816008-0	Bracket
A505	257815401-0	Balance Knob	B043	259716004-0	Bracket
A506	257815401-0	Volume Knob	B044	259711201-0	Shaft
A509	257815402-0	Bass Knob	B045	133611201-0	Shaft
A510	257815402-0	Treble Knob	B049	257816010-0	Heat Sink + Chassis K Bracket
A511	257815403-0	Bass Knob	B050	257816011-0	Heat Sink + Chassis K Bracket
A512	257815403-0	Treble Knob	B051	257816012-2	Rotary Sw. + Chassis K Bracket
A513	257815404-0	Antenna Tuning Knob	B052	257816013-2	Bracket
A515	257812001-0	Dubbing In Insulator	B055	257810950-0	FM Tuner Shield K
A516	257812001-0	Dubbing Out Insulator	B056	257810901-0	Shield
A517	257812001-0	Head Phones Insulator	B057	257810102-0	Support
A520	257715402-0	Tape Mon. Knob	B058	257810102-0	Support
A521	257715402-0	Mono L Knob	B059	257810102-0	Support
A522	257715402-0	Mono R Knob	B060	257810102-0	Support
A523	257715402-0	Hi Blend Knob	B062	257810902-0	FM Tuner Shield
A524	257715402-0	Low Filter Knob	B068	257810906-0	Tone Volume Shield
A525	257715402-0	Hi Filter Knob	B070	257810907-2	10P Terminal Shield
A526	257715402-0	Loudness Knob	B072	257810908-2	Shield
A527	257715402-0	Muting Off Knob	B080	257805150-0	Pointer Guide K
A528	257715402-0	Main Speaker Knob	B081	257805101-0	Guide
A529	257715402-0	Rem Speaker Knob	B082	254811201-0	Shaft
			B086	257810650-0	Fly Wheel Bearing K
			B087	257810401-0	Retainer
			B088	257710601-0	Bearing
			B091	257805301-0	Lamp Cover

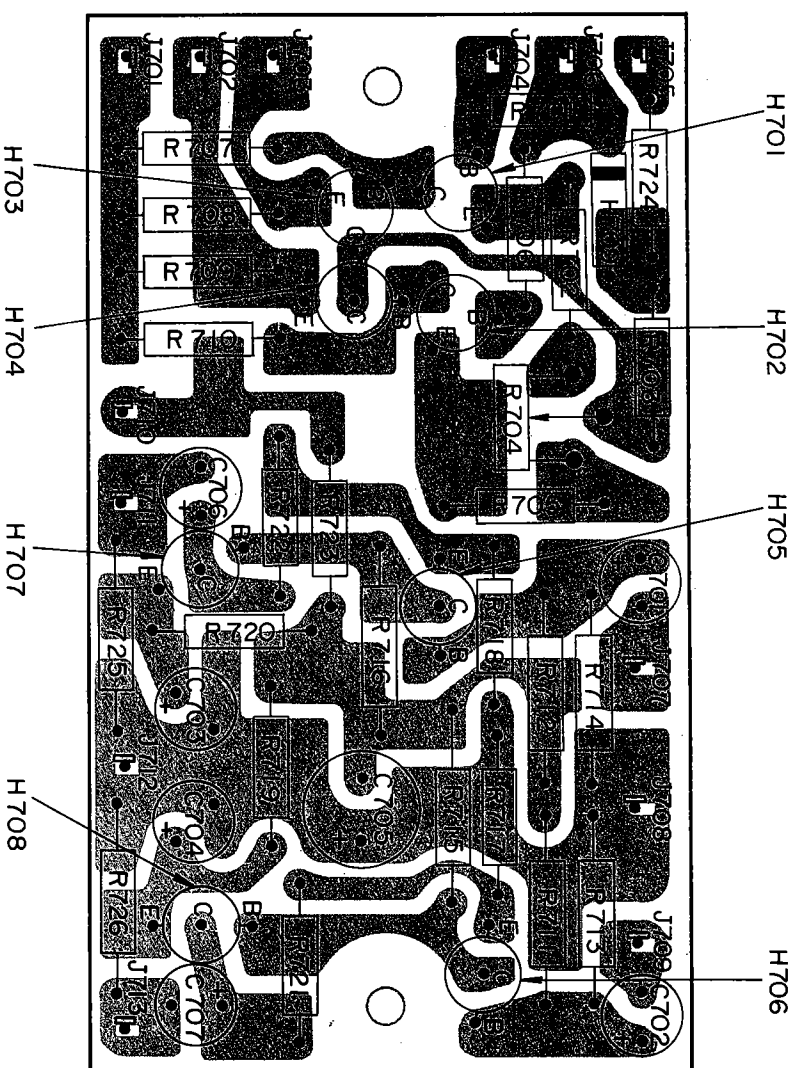

Figure 11 DC Amplifier and FM Audio Amplifier Assembly P700 Component Locations

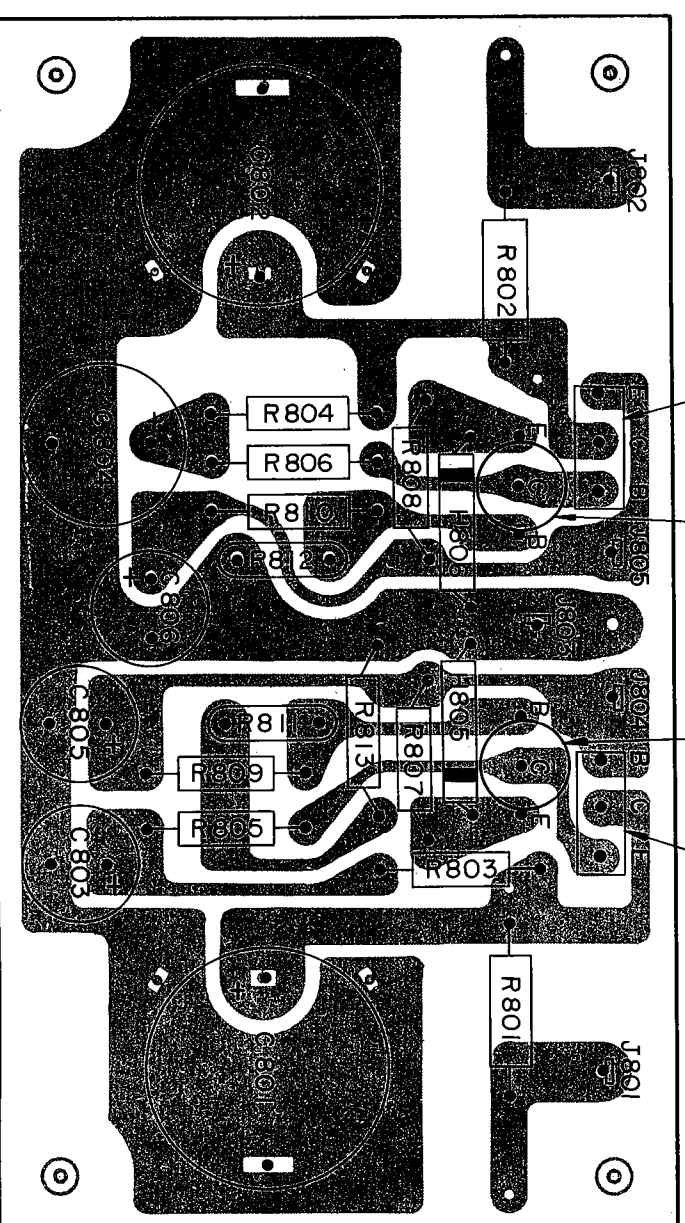

Figure 12 Regulated Power Supply Unit Assembly P800 Component Locations

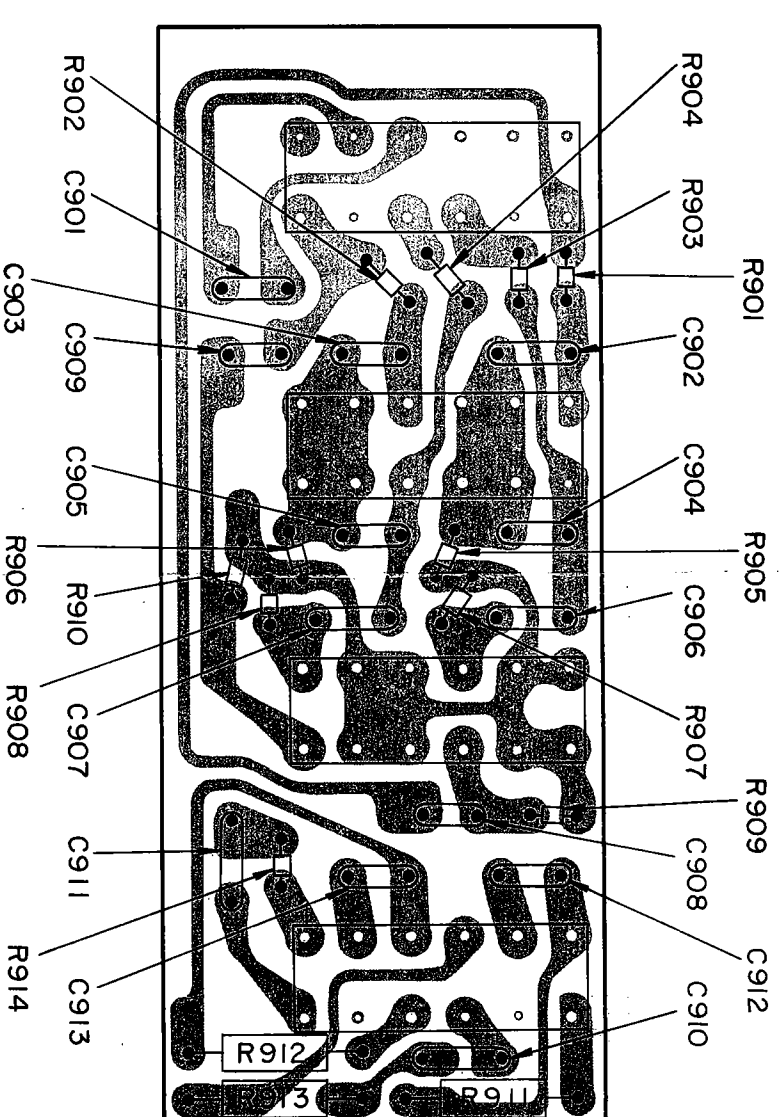

Figure 13 Hi Blend, Low Filter, Hi Filter and Loudness Switches Unit Assembly P900 Component Locations

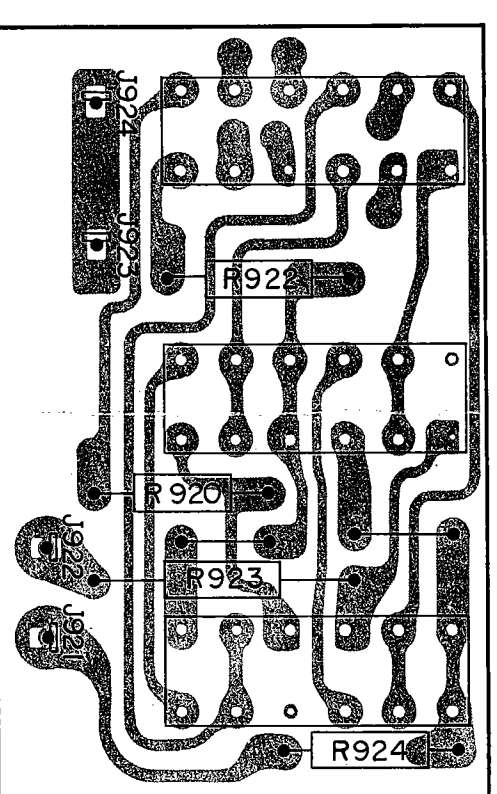

Figure 14 Tape Monitor and Mono in L.R. Switches Unit Assembly P920 Component Locations

REF. MARANTZ
DESIG. PART NO. DESCRIPTION

B093 257811202-2 Fly Wheel Shaft
 B095 257805501-0 Head Phones Collar
 B096 257805501-0 Head Phones Collar
 B097 257805501-0 Head Phones Collar
 B098 257805501-0 Head Phones Collar
 B099 257805501-0 Head Phones Collar
 B100 257805501-0 Head Phones Collar

 B105 257810103-0 Heat-Sink + Punched
 Plate Support
 B106 257810103-0 Heat-Sink + Punched
 Plate Support
 B107 257810103-0 Heat-Sink + Punched
 Plate Support

 B111 257810104-0 Escutcheon+Chassis(K)Support
 B112 257810104-0 Escutcheon+Chassis(K)Support
 B113 257810104-0 Escutcheon Front Bracket (K)
 Support
 B114 257810104-0 Escutcheon Front Bracket (K)
 Support

 B121 257810105-0 10P Terminal Support
 B122 257810105-0 10P Terminal Support
 B123 257810105-0 10P Terminal Support
 B124 257810105-0 10P Terminal Support
 B125 257810105-0 P.C Board Support
 B126 257810105-0 P.C Board Support
 B128 257816015-0 Relay Bracket

 B131 124705850-0 Gear (K)
 B132 124705801-0 Gear
 B133 124705802-0 Gear
 B134 121811202-0 Shaft
 B136 124705850-0 Gear (K)
 B137 124705801-0 Gear
 B138 124705802-0 Gear
 B139 121811202-0 Gear

 B141 138200503-0 Clamper
 B142 138200503-0 Clamper
 B143 138200503-0 Clamper
 B144 138200503-0 Clamper
 B145 138200503-0 Clamper
 B146 138200503-0 Clamper
 B147 138200503-0 Clamper
 B148 138200503-0 Clamper
 B149 138200503-0 Clamper
 B150 138200503-0 Clamper

 D151 138200503-0 Clamper
 D152 138200503-0 Clamper
 D153 138200503-0 Clamper

 B161 257905502-0 Push Switch(Ant Tuning) Collar
 B162 257905502-0 Push Switch(Ant Tuning) Collar

 B170 120225801-0 Hook
 B171 71101239M-0 Spring

 B174 71400219Q-0 MPX Lamp Spring

REF. MARANTZ
DESIG. PART NO. DESCRIPTION

B178 71400149Q-0 Knob Spring
 B179 71400149Q-0 Knob Spring

 B182 257716017-0 Circuit Breaker Bracket
 B184 257700501-0 Coil + Chassis (K) Clamper
 B185 257700501-0 Coil + Chassis (K) Clamper
 B187 53228059E-0 Muting Level Nut

 B189 71101559M-0 Gear Spring
 B190 71101559M-0 Gear Spring

 B192 114325904-0 Bush
 B193 114325904-0 Bush

 B501 257815901-0 Drum
 B503 257812002-0 Head Phone Insulator
 B504 257812003-0 Head Phone Insulator
 B506 257811801-0 Power Transistor Spacer
 B507 257811802-0 Power Transistor Spacer
 B508 257811802-0 Power Transistor Spacer
 B509 257811802-0 Power Transistor Spacer
 B510 257811802-0 Power Transistor Spacer

 B513 257805601-0 Buffer

 B517 257805302-2 Cover
 B518 257805303-0 Cover

 B520 257825902-0 MPX Stereo Lamp Bush

 B543 257711803-0 Lid Spacer
 B544 257726201-0 Pulley
 B545 257726201-0 Pulley
 B546 257726201-0 Pulley
 B547 257726201-0 Pulley
 B548 257726201-0 Pulley

 B550 59114289C-0 Coil+Chassis(K) Washer
 B551 59114289C-0 Coil+Chassis(K) Washer
 B552 59110339H-0 Coil+Chassis(K) Washer
 B553 59110339H-0 Coil+Chassis(K) Washer
 B556 145525901-0 AC Cord Bush
 B557 145525901-0 Ant. Cord Bush
 B559 72081604A-0 62³/₄" String

 B561 250605701-0 Leg
 B562 250605701-0 Leg
 B563 250605701-0 Leg
 B564 250605701-0 Leg
 B566 141511801-0 Fly Wheel Spacer
 B567 257710602-0 Fly Wheel Bearing
 B569 257711805-0 MPX Lamp Spacer
 B570 149325902-0 MPX Lamp Bush

 B571 149325902-0 Meter Lamp Bush
 B572 149325902-0 Meter Lamp Bush
 B573 102025901-0 Bush
 B574 102025901-0 Bush

 D001 51570306B-0 Power Amp P.C Board
 P. Tapt Screw

REF. DESIG.	MARANTZ PART NO.	DESCRIPTION
D002	51570306B-0	Power Amp P.C Board P. Tapt Screw
D003	51570306B-0	Power Amp P.C Board P. Tapt Screw
D004	51570306B-0	Power Amp P.C Board P.Tapt Screw
D005	51570306B-0	Power Amp P.C Board P. Tapt Screw
D006	51570306B-0	Power Amp P.C Board P. Tapt Screw
D007	51570306B-0	IF P.C Board P.Tapt Screw
D008	51570306B-0	IF P.C Board P.Tapt Screw
D009	51570306B-0	IF P.C Board P.Tapt Screw
D010	51570306B-0	IF P.C Board P.Tapt Screw
D011	51570306B-0	IF P.C Board P.Tapt Screw
D012	51570306B-0	IF P.C Board P.Tapt Screw
D013	51570306B-0	Supply P.C Board P. Tapt Screw
D014	51570306B-0	Supply P.C Board P. Tapt Screw
D015	51570308B-0	Supply P.C Board P. Tapt Screw
D016	51570308B-0	Supply P.C Board P. Tapt Screw
D017	51570306B-0	Tone P.C Board P. Tapt Screw
D018	51570306B-0	Tone P.C Board P. Tapt Screw
D019	51570306B-0	Tone P.C Board P. Tapt Screw
D020	51570306B-0	Tone P.C Board P. Tapt Screw
D021	51570306B-0	Phone P.C Board P. Tapt Screw
D022	51570306B-0	Phone P.C Board P. Tapt Screw
D023	51570306B-0	Phone P.C Board P. Tapt Screw
D024	51570306B-0	Phone P.C Board P. Tapt Screw
D025	51570306B-0	Meter P.C Board P. Tapt Screw
D026	51570306B-0	Meter P.C Board P. Tapt Screw
D027	51570306B-0	AM RF P.C Board P. Tapt Screw
D028	51570306B-0	AM RF P.C Board P. Tapt Screw
D029	51570306B-0	AM RF P.C Board P. Tapt Screw
D030	51570306B-0	FM RF P.C Board P. Tapt Screw
D031	51570306B-0	FM RF P.C Board P. Tapt Screw
D032	51570306B-0	FM RF P.C Board P. Tapt Screw

REF. DESIG.	MARANTZ PART NO.	DESCRIPTION
D033	51570306B-0	FM RF P.C Board P. Tapt Screw
D041	51570306B-0	7P Terminal P.Tapt Screw
D042	51570306B-0	7P Terminal P.Tapt Screw
D043	51570306B-0	7P Terminal P.Tapt Screw
D044	51570306B-0	7P Terminal P.Tapt Screw
D045	51570306B-0	7P Terminal P.Tapt Screw
D046	51570306B-0	7P Terminal P.Tapt Screw
D047	51570306B-0	7P Terminal P.Tapt Screw
D048	51570306B-0	7P Terminal P.Tapt Screw
D049	51570306B-0	7P Terminal P.Tapt Screw
D050	51570306B-0	7P Terminal P.Tapt Screw
D051	51570306B-0	5P Terminal P.Tapt Screw
D052	51570306B-0	5P Terminal P.Tapt Screw
D053	51570306B-0	Bracket+Chassis K P. Tapt Screw
D054	51570306B-0	Bracket+Chassis K P. Tapt Screw
D055	51570306B-0	Bracket+Chassis K Pulley Bracket P. Tapt Screw
D056	51570306B-0	Pulley Bracket P.Tapt Screw
D057	51570306B-0	Condencer P. Tapt Screw
D058	51570306B-0	Condencer P. Tapt Screw
D059	51570306B-0	Condencer P. Tapt Screw
D060	51570306B-0	Condencer P. Tapt Screw
D061	51570306B-0	Shield (Tone) P.Tapt Screw
D062	51570306B-0	Shield (Tone) P.Tapt Screw
D063	51570306B-0	Bracket P. Tapt Screw
D064	51570306B-0	Bracket P. Tapt Screw
D065	51570306B-0	FRONT Bracket+Chassis K P. Tapt Screw
D066	51570306B-0	FRONT Bracket+Chassis K P. Tapt Screw
D067	51570306B-0	FRONT Bracket+Chassis K P. Tapt Screw
D068	51570306B-0	FRONT Bracket+Chassis K P. Tapt Screw
D069	51570306B-0	Shield P. Tapt Screw
D070	51570306B-0	Shield P. Tapt Screw
D071	51570306B-0	P. Tapt Screw
D072	51570306B-0	P. Tapt Screw
D073	51570306B-0	P. Tapt Screw
D074	51570306B-0	P. Tapt Screw
D081	51570306B-0	Transistor Socket P.Tapt Screw
D082	51570306B-0	Transistor Socket P.Tapt Screw
D083	51570306B-0	Transistor Socket P.Tapt Screw
D084	51570306B-0	Transistor Socket P.Tapt Screw
D085	51570306B-0	Transistor Socket P.Tapt Screw
D086	51570306B-0	Transistor Socket P.Tapt Screw
D087	51570306B-0	Transistor Socket P.Tapt Screw
D088	51570306B-0	Transistor Socket P.Tapt Screw
D089	51570306B-0	Push Terminal P. Tapt Screw
D090	51570306B-0	Push Terminal P. Tapt Screw

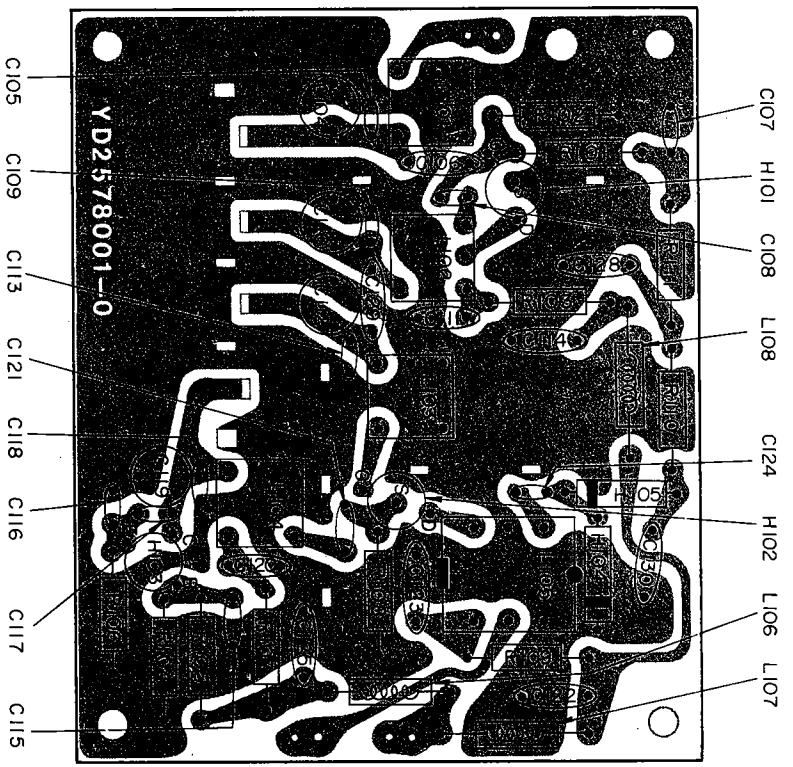

Figure 5 FM Front End Assembly P100 Component Locations

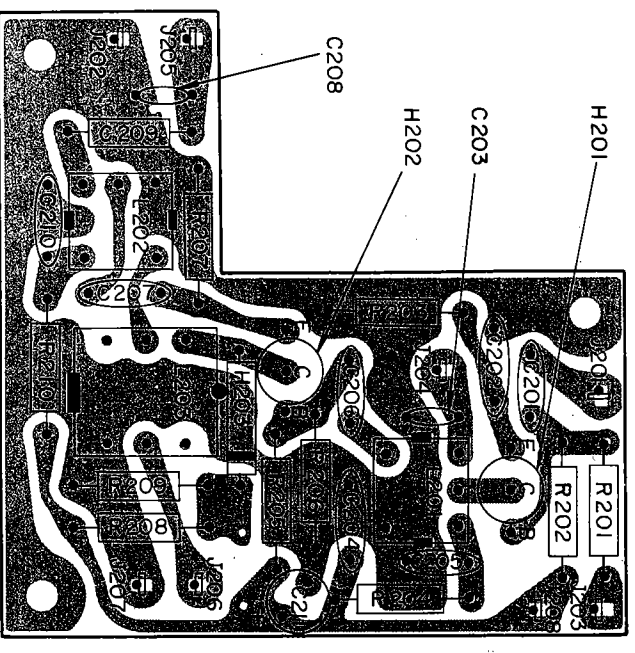

Figure 6 AM Front End Assembly P200 Component Locations

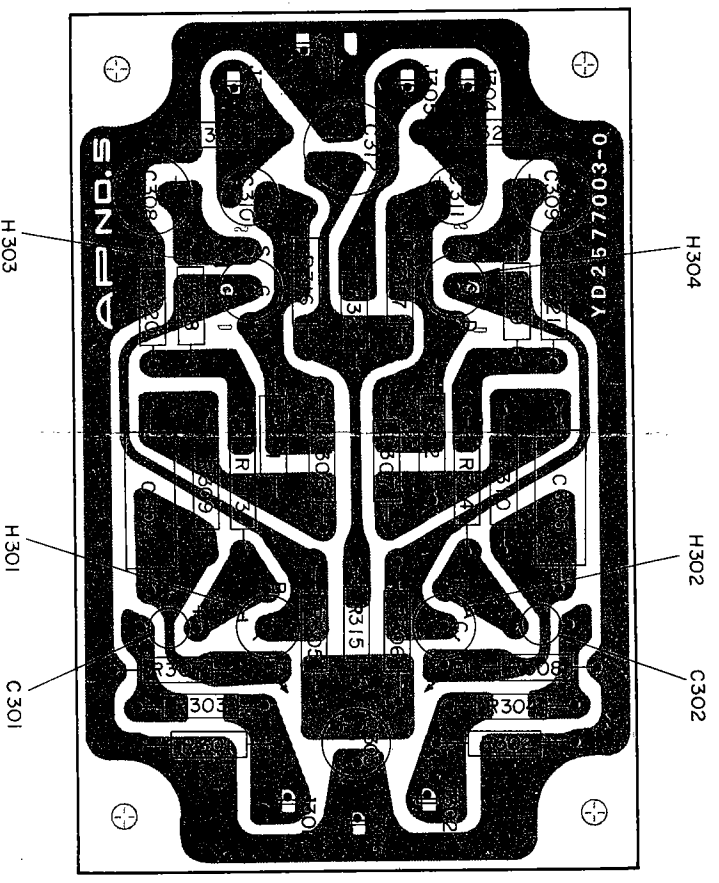

Figure 7 PHONO Amplifier Assembly P300 Component Locations

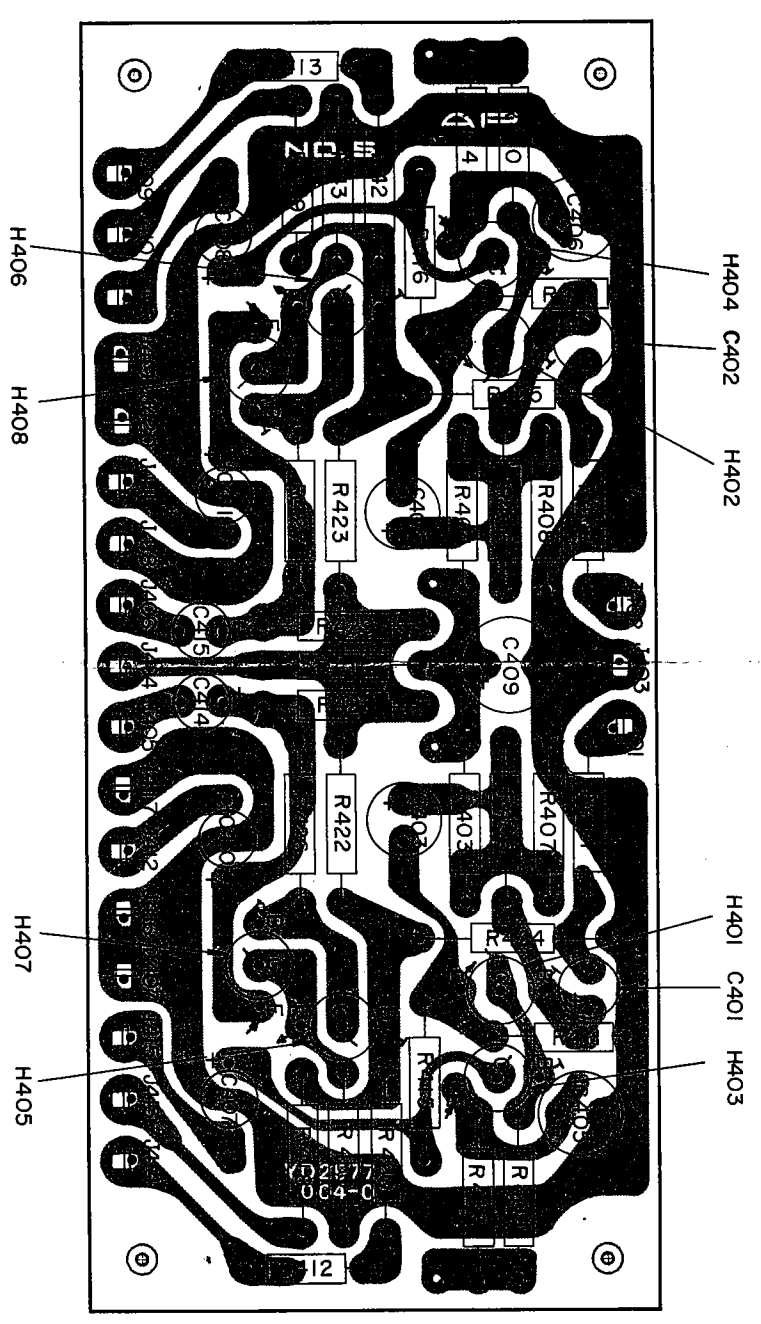

Figure 8 Tone and Pre Amplifier Assembly P400 Component Locations

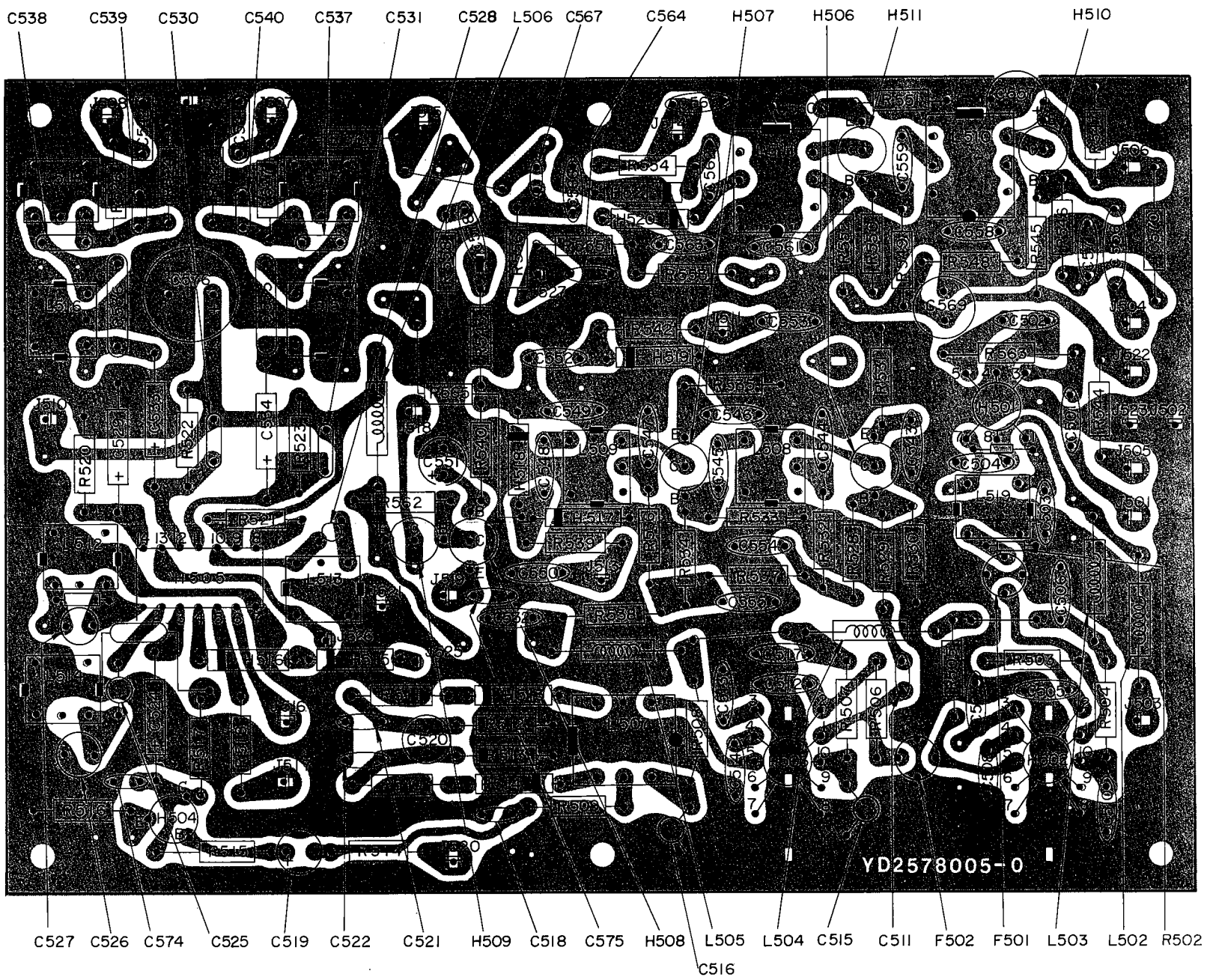

Figure 9 AM-FM IF and FM-MPX Demodulator Assembly P500 Component Locations

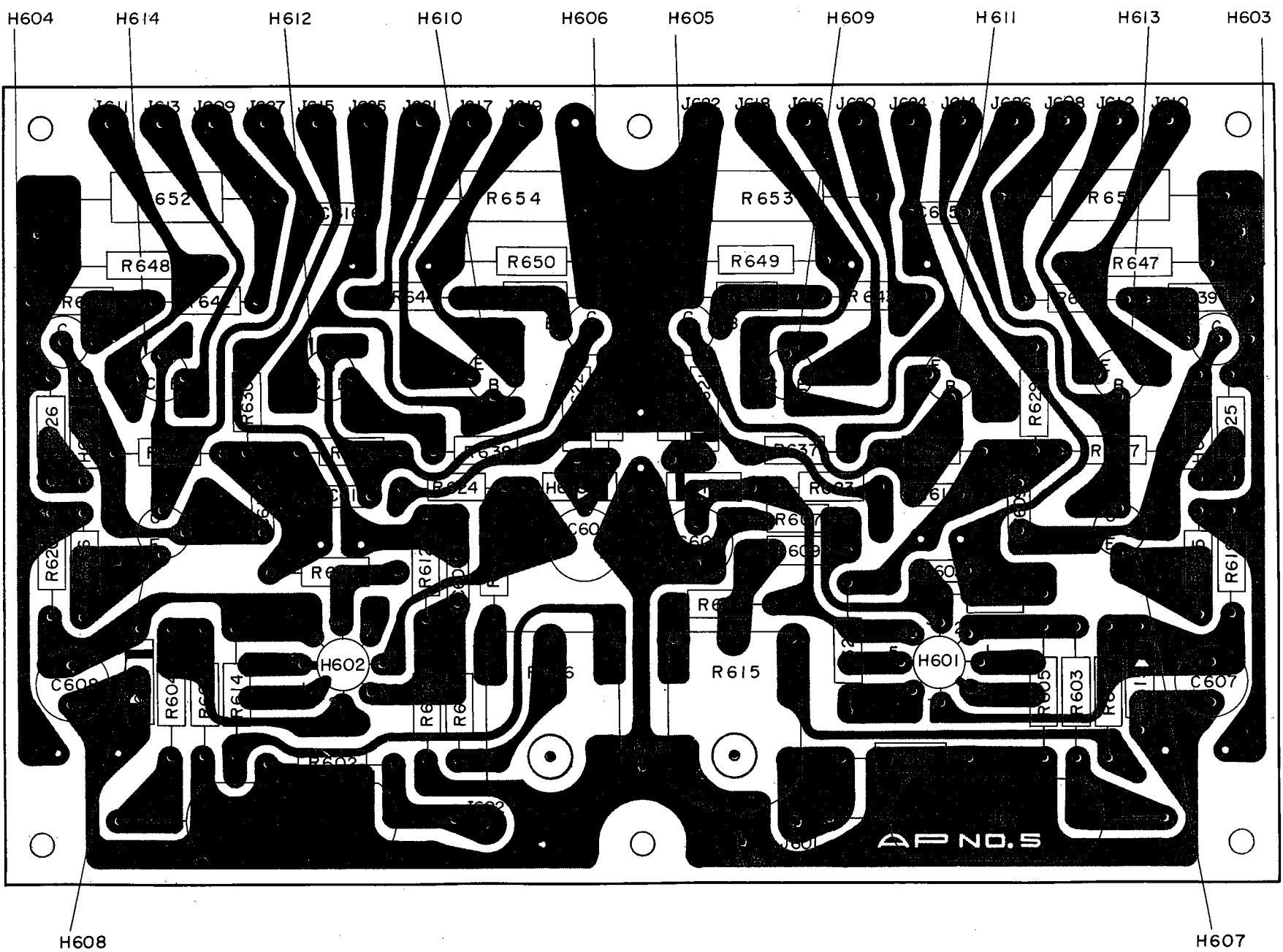

Figure 10 Main Amplifier Assembly P600 Component Locations

marantz®	model number 22 . 23 . 24 . 25	bulletin number M-G-7
	for serial numbers ALL	
SERVICE BULLETIN	subject PARTS SUBSTITUTION LIST	
	engineering approval N/A	date 3-15-73

Below is a list of semiconductors used in some Marantz models. These parts can be directly interchanged with either the alternate Marantz parts or the commercially available type listed.

MODEL 22 RECEIVER

MARANTZ PART NUMBER	ALTERNATE MARANTZ PART NUMBER	COMMERCIAL PART NUMBER
HT 9004100	462-1006	SJ-2000 (Motorola)
HT 7004100	461-1005	SJ-2001 "
HC 1000217	466-1000	MC-1741 "
HC 1000111	466-1004	UA-703 (Fairchild)
HC 1000114	466-1003	CA-3011 (RCA)
HC 1000117	466-1002	MC-1304 (Motorola)

MODEL 23 & 24

HC 1000114	466-1003	CA-3011 (RCA)
HC 1000111	466-1004	UA-703 (Fairchild)
HC 1000117	466-1002	MC-1304 (Motorola)

MODEL 25 RECEIVER

HT 9000310	462-1005	SJ-2008 (Motorola)
HT 9000310	461-1004	SJ-2009 "
HC 1000217	466-1000	MC-1741 "

This bulletin supersedes the previous service bulletin 70-10/0-0 dated 5-14-70 on this subject.



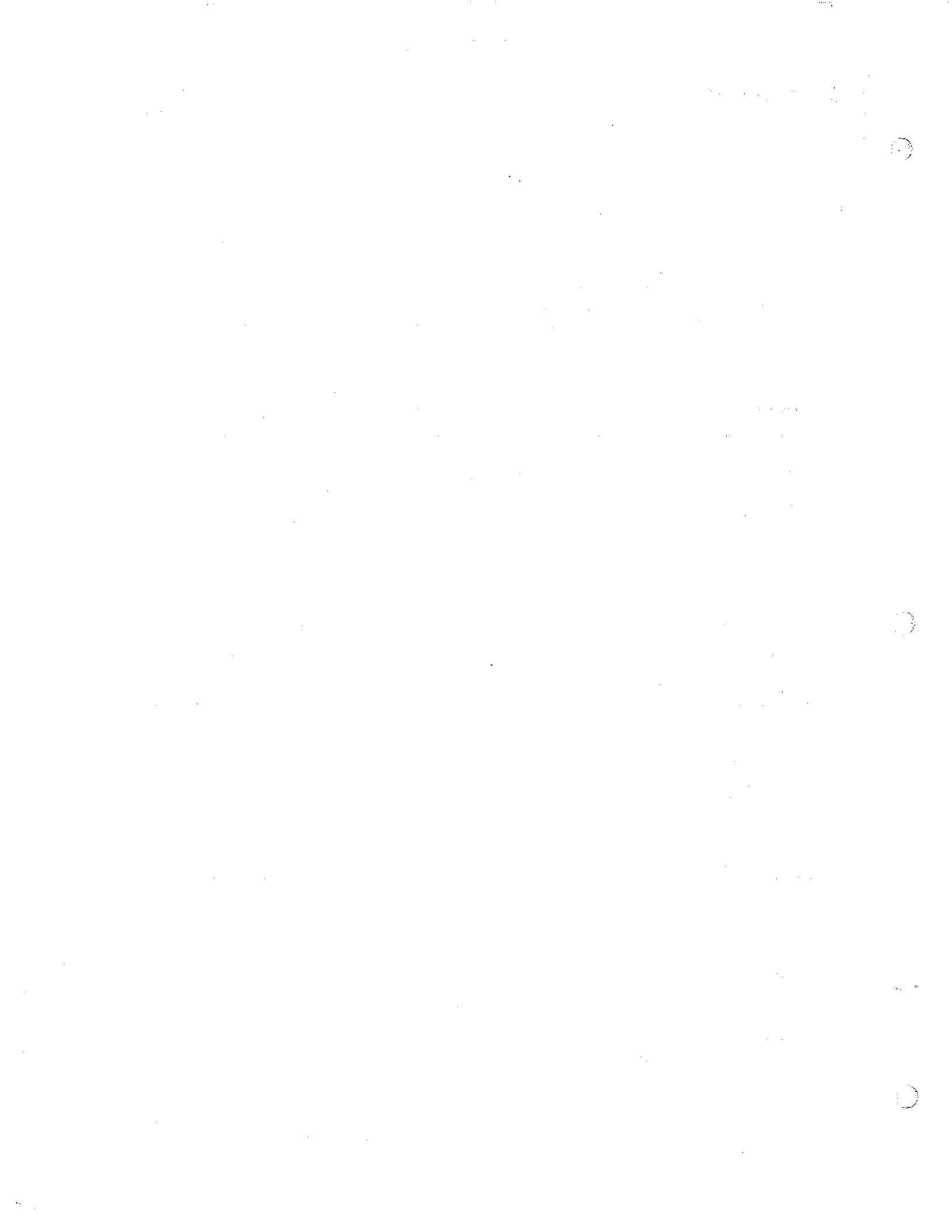

marantz [®]	model number	22	bulletin number	M-22-6
	for serial numbers	ALL		
	subject	ELIMINATING AM "WHISTLING" ON EDGE OF PASSBAND		
	engineering approval	N/A	date	3-14-73
SERVICE BULLETIN				

To eliminate the whistling sounds that occur when tuning stations, (prior to full muting), we suggest the following modification:

Install a 180K, $\frac{1}{2}$ watt resistor from the collector of H509 to ground. Transistor H509 is located on board number P500.

This bulletin supersedes the previous service bulletin 70-13/22-2 on this subject, dated 6-22-70.

Hector E. Gervasio, Manager
Technical Services

Schematic Diagram

ICs	IC201	IC501	IC502	IC801	PC802	IC801
Transistors	Q501-Q506		Q507-Q510	Q801-Q804	Q805-Q814	Q801-Q814
Diodes	ZD201 ZD202	D501 D503 D504 D506	D502 D505 D507 D508 D509	ZD803 ZD804	D806 D807 D808 D804 D805 D801-D803	D810-D811 LD801

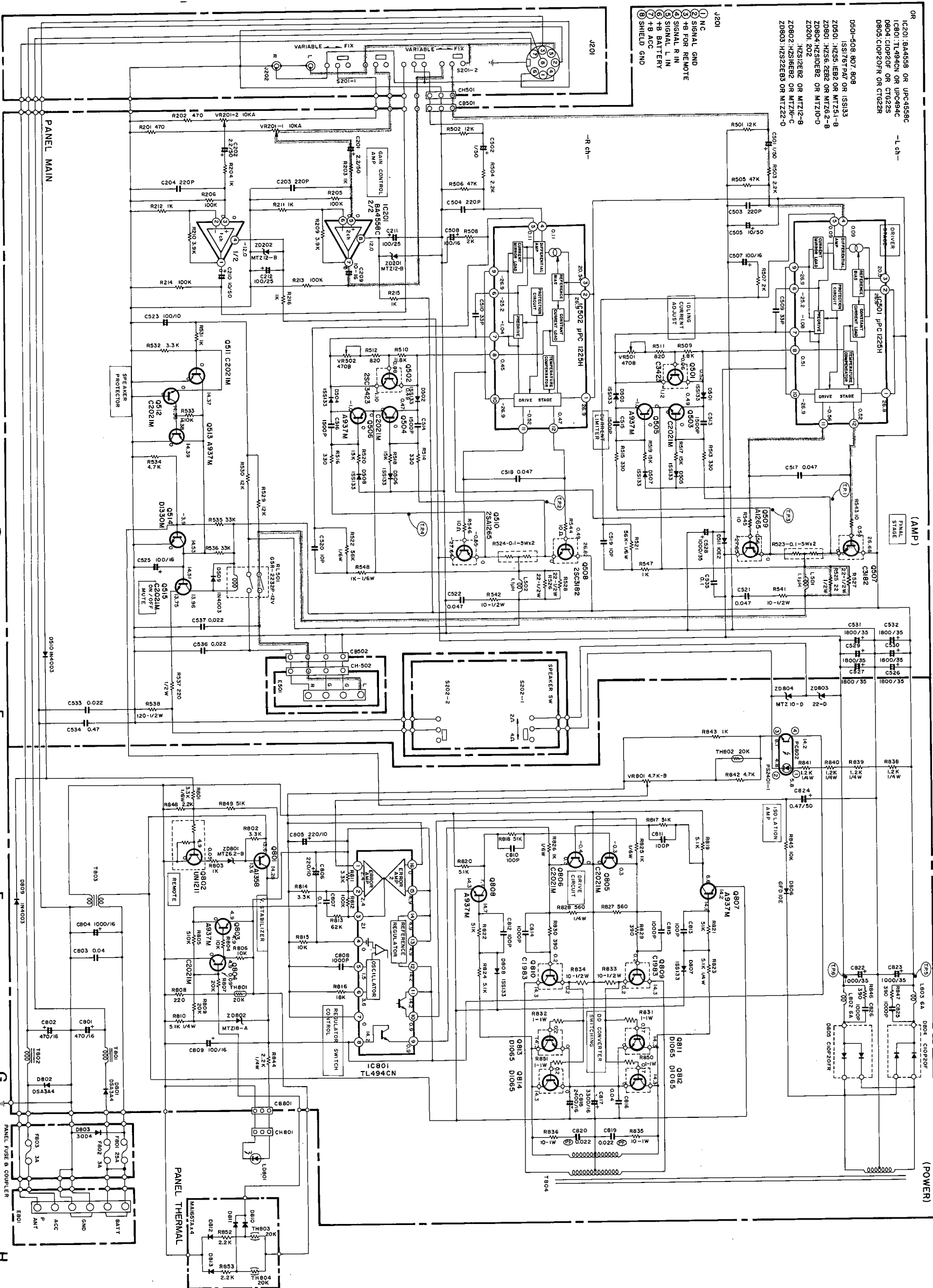

1
2
3
4
5
6

age measuring conditions
ply voltage
asuring instrument
asuring standard

14.4V DC
igital Multimeter
With respect to the
primary ground potential
(POWER)
With respect to the
secondary ground
potential (AMPLIFIER)
No signal input

1
2
3
4
5
6

1
2
3
4
5
6

1
2
3
4
5
6

1
2
3
4
5
6

A B C D E F G H



the crowning touch of perfection



marantz

MODEL 22R SERVICE MANUAL

This Service Manual is the first revised edition for model 22.

Included in this service manual are schematic diagram and individual parts list.

On the circuit description alignment method and repairing hints, refer to the original service manual.

TABLE OF CONTENTS

Schematic Diagram	1
Parts List	2

marantz



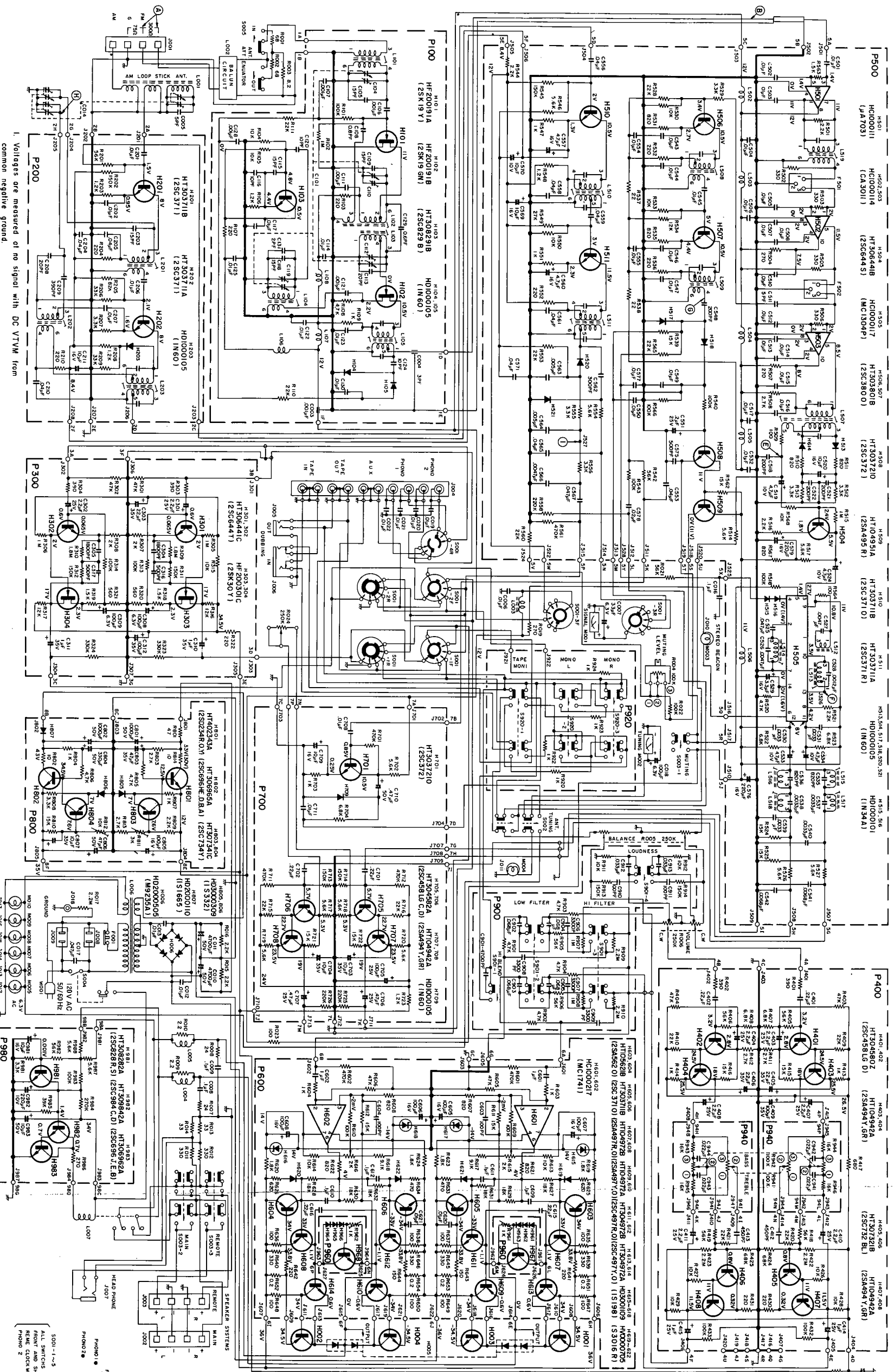

Section	Part Number	Part Number	Part Number	Part Number	Part Number	Part Number	Part Number	Part Number	Part Number
P500	H501	H502	H503	H504	H505	H506	H507	H508	H509
	H510	H511	H512	H513	H514	H515	H516	H517	H518
	H519	H520	H521	H522	H523	H524	H525	H526	H527
	H528	H529	H530	H531	H532	H533	H534	H535	H536
	H537	H538	H539	H540	H541	H542	H543	H544	H545
	H546	H547	H548	H549	H550	H551	H552	H553	H554
	H555	H556	H557	H558	H559	H560	H561	H562	H563
	H564	H565	H566	H567	H568	H569	H570	H571	H572
	H573	H574	H575	H576	H577	H578	H579	H580	H581
	H582	H583	H584	H585	H586	H587	H588	H589	H590
P600	H601	H602	H603	H604	H605	H606	H607	H608	H609
	H610	H611	H612	H613	H614	H615	H616	H617	H618
	H619	H620	H621	H622	H623	H624	H625	H626	H627
	H628	H629	H630	H631	H632	H633	H634	H635	H636
	H637	H638	H639	H640	H641	H642	H643	H644	H645
	H646	H647	H648	H649	H650	H651	H652	H653	H654
	H655	H656	H657	H658	H659	H660	H661	H662	H663
	H664	H665	H666	H667	H668	H669	H670	H671	H672
	H673	H674	H675	H676	H677	H678	H679	H680	H681
	H682	H683	H684	H685	H686	H687	H688	H689	H690
P700	H701	H702	H703	H704	H705	H706	H707	H708	H709
	H710	H711	H712	H713	H714	H715	H716	H717	H718
	H719	H720	H721	H722	H723	H724	H725	H726	H727
	H728	H729	H730	H731	H732	H733	H734	H735	H736
	H737	H738	H739	H740	H741	H742	H743	H744	H745
	H746	H747	H748	H749	H750	H751	H752	H753	H754
	H755	H756	H757	H758	H759	H760	H761	H762	H763
	H764	H765	H766	H767	H768	H769	H770	H771	H772
	H773	H774	H775	H776	H777	H778	H779	H780	H781
	H782	H783	H784	H785	H786	H787	H788	H789	H790
P800	H801	H802	H803	H804	H805	H806	H807	H808	H809
	H810	H811	H812	H813	H814	H815	H816	H817	H818
	H819	H820	H821	H822	H823	H824	H825	H826	H827
	H828	H829	H830	H831	H832	H833	H834	H835	H836
	H837	H838	H839	H840	H841	H842	H843	H844	H845
	H846	H847	H848	H849	H850	H851	H852	H853	H854
	H855	H856	H857	H858	H859	H860	H861	H862	H863
	H864	H865	H866	H867	H868	H869	H870	H871	H872
	H873	H874	H875	H876	H877	H878	H879	H880	H881
	H882	H883	H884	H885	H886	H887	H888	H889	H890
P900	H901	H902	H903	H904	H905	H906	H907	H908	H909
	H910	H911	H912	H913	H914	H915	H916	H917	H918
	H919	H920	H921	H922	H923	H924	H925	H926	H927
	H928	H929	H930	H931	H932	H933	H934	H935	H936
	H937	H938	H939	H940	H941	H942	H943	H944	H945
	H946	H947	H948	H949	H950	H951	H952	H953	H954
	H955	H956	H957	H958	H959	H960	H961	H962	H963
	H964	H965	H966	H967	H968	H969	H970	H971	H972
	H973	H974	H975	H976	H977	H978	H979	H980	H981
	H982	H983	H984	H985	H986	H987	H988	H989	H990
P920	H991	H992	H993	H994	H995	H996	H997	H998	H999
	H1000	H1001	H1002	H1003	H1004	H1005	H1006	H1007	H1008
	H1009	H1010	H1011	H1012	H1013	H1014	H1015	H1016	H1017
	H1018	H1019	H1020	H1021	H1022	H1023	H1024	H1025	H1026
	H1027	H1028	H1029	H1030	H1031	H1032	H1033	H1034	H1035
	H1036	H1037	H1038	H1039	H1040	H1041	H1042	H1043	H1044
	H1045	H1046	H1047	H1048	H1049	H1050	H1051	H1052	H1053
	H1054	H1055	H1056	H1057	H1058	H1059	H1060	H1061	H1062
	H1063	H1064	H1065	H1066	H1067	H1068	H1069	H1070	H1071
	H1072	H1073	H1074	H1075	H1076	H1077	H1078	H1079	H1080
P940	H1081	H1082	H1083	H1084	H1085	H1086	H1087	H1088	H1089
	H1090	H1091	H1092	H1093	H1094	H1095	H1096	H1097	H1098
	H1099	H1100	H1101	H1102	H1103	H1104	H1105	H1106	H1107
	H1108	H1109	H1110	H1111	H1112	H1113	H1114	H1115	H1116
	H1117	H1118	H1119	H1120	H1121	H1122	H1123	H1124	H1125
	H1126	H1127	H1128	H1129	H1130	H1131	H1132	H1133	H1134
	H1135	H1136	H1137	H1138	H1139	H1140	H1141	H1142	H1143
	H1144	H1145	H1146	H1147	H1148	H1149	H1150	H1151	H1152
	H1153	H1154	H1155	H1156	H1157	H1158	H1159	H1160	H1161
	H1162	H1163	H1164	H1165	H1166	H1167	H1168	H1169	H1170
P980	H1171	H1172	H1173	H1174	H1175	H1176	H1177	H1178	H1179
	H1180	H1181	H1182	H1183	H1184	H1185	H1186	H1187	H1188
	H1189	H1190	H1191	H1192	H1193	H1194	H1195	H1196	H1197
	H1198	H1199	H1200	H1201	H1202	H1203	H1204	H1205	H1206
	H1207	H1208	H1209	H1210	H1211	H1212	H1213	H1214	H1215
	H1216	H1217	H1218	H1219	H1220	H1221	H1222	H1223	H1224
	H1225	H1226	H1227	H1228	H1229	H1230	H1231	H1232	H1233
	H1234	H1235	H1236	H1237	H1238	H1239	H1240	H1241	H1242
	H1243	H1244	H1245	H1246	H1247	H1248	H1249	H1250	H1251
	H1252	H1253	H1254	H1255	H1256	H1257	H1258	H1259	H1260

1. Voltages are measured at no signal with DC VTVM from common negative ground.

2. Voltages in parentheses are values measured at 1KHz FM stereo signal applied. Stereo switch in stereo position.

SCHEMATIC DIAGRAM OF MODEL 22R

1970-7-13

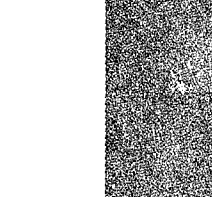
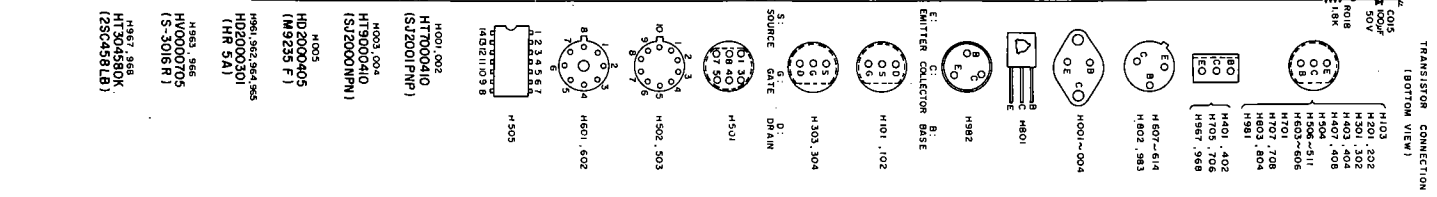
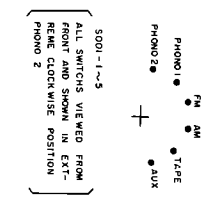

PARTS LIST

REF. DESIG.	MARANTZ PART NO.	DESCRIPTION	REF. DESIG.	MARANTZ PART NO.	DESCRIPTION	REF. DESIG.	MARANTZ PART NO.	DESCRIPTION
A001	2578063013	Escutcheon	B007	2578160020	Bracket	B112	2578101040	Support
A002	2578003010	Punched Plate	B008	2578160020	Bracket	B113	2578101040	Support
A003	2578257012	Lid	B009	2578160020	Bracket	B114	2578101040	Support
A004	2578267014	Heat Sink	B010	2578160020	Bracket	B121	2578101050	Support
A005	2578103012	Pointer	B011	2578160090	Bracket	B122	2578101050	Support
A006	2578265012	Indicator	B012	2763160500	Bracket K	B123	2578101050	Support
A008	2578067010	Cap	B013	2763160010	Bracket	B125	2578101050	Support
A009	2578067010	Cap	B014	2578101010	Support	B126	2578101050	Support
A010	2578067010	Cap	B015	2578101010	Support	B128	2578160152	Bracket
A011	2578067020	Cap	B016	2578101010	Support	B131	1247058500	Gear K
A012	2578067020	Cap	B018	2578160512	Bracket K	B132	1247058010	Gear
A013	2578067030	Cap	B019	2578160042	Bracket	B133	1247058020	Gear
A014	2578067030	Cap	B020	2578112010	Shaft	B134	1218112020	Shaft
A016	2577067022	Cap	B022	2578160522	Bracket K	B136	1247058010	Gear
A017	2577067022	Cap	B023	2578160052	Bracket	B137	1247058020	Gear
A018	2577067022	Cap	B024	2578160062	Bracket	B138	1247058020	Gear
A019	2577067022	Cap	B026	5502030410	S. H. Rivet	B139	1218112020	Gear
A020	2577067022	Cap	B028	2578160530	S. H. Rivet	B140	1382005030	Clamper
A021	2577067022	Cap	B029	2578160070	Bracket K	B142	1382005030	Clamper
A022	2577067022	Cap	B029	2578160070	Bracket	B143	1382005030	Clamper
A023	2577067022	Cap	B030	2577112020	Shaft	B144	1382005030	Clamper
A024	2577067022	Cap	B031	2577112020	Shaft	B145	1382005030	Clamper
A025	2577067022	Cap	B041	2578160540	Bracket K	B146	1382005030	Clamper
A026	2577067022	Cap	B042	2578160080	Bracket	B147	1382005030	Clamper
A028	2577063022	Escutcheon	B043	2597160040	Bracket	B148	1382005030	Clamper
A029	2577273010	Fly Wheel	B044	2597112010	Shaft	B149	1382005030	Clamper
A030	2577063032	Escutcheon	B045	1336112010	Shaft	B150	1382005030	Clamper
A501	2578401012	Frame	B049	2578160102	Bracket	B151	1382005030	Clamper
A502	2763302012	Dial	B050	2578160112	Bracket	B152	1382005030	Clamper
A503	2578107012	Sheet	B051	2578160122	Bracket	B153	1382005030	Clamper
A504	2578107030	Sheet	B053	2578160170	Bracket	B154	1382005030	Clamper
A505	2578154010	Knob	B055	2578109502	Shield K	B155	1382005030	Clamper
A506	2578154010	Knob	B056	2578109510	Shield	B162	2579055020	Collar
A507	2578154010	Knob	B057	2578101020	Support	B166	2722160030	Bracket
A509	2578154020	Knob	B058	2578101020	Support	B168	2578160160	Bracket
A510	2578154020	Knob	B059	2578101020	Support	B170	1202258010	Hook
A511	2578154030	Knob	B062	2578101020	Support	B171	71101239M0	Spring
A512	2578154030	Knob	B062	2578109022	Shield	B178	71400149Q0	Spring
A513	2578154040	Knob	B068	2578109060	Shield	B179	71400149Q0	Spring
A515	2578120010	Insulator	B070	2578109070	Shield	B182	2577160170	Bracket
A516	2578120010	Insulator	B072	2578109080	Shield	B184	2577005010	Clamper
A517	2578120010	Insulator	B080	2578051500	Guide K	B185	2577005010	Clamper
A519	2763107010	Sheet	B081	2578051010	Guide	B187	53228059E0	Nut
A520	2577154020	Knob	B082	2548112010	Shaft	B189	71101559M0	Spring
A521	2577154020	Knob	B086	2578106500	Bearing K	B190	71101559M0	Spring
A522	2577154020	Knob	B087	2578104010	Retainer	B192	1143259040	Bush
A523	2577154020	Knob	B088	2577106010	Bearing	B193	1143259040	Bush
A524	2577154020	Knob	B091	2763053010	Cover	B501	2578159010	Drum
A525	2577154020	Knob	B093	2578112022	Shaft	B503	2578120020	Insulator
A526	2577154020	Knob	B095	2578055010	Collar	B504	2578120030	Insulator
A527	2577154020	Knob	B096	2578055010	Collar	B507	2578118020	Spacer
A528	2577154020	Knob	B097	2578055010	Collar	B508	2578118020	Spacer
A529	2577154020	Knob	B098	2578055010	Collar	B509	2578118020	Spacer
A530	2577154020	Knob	B099	2578055010	Collar	B510	2578118020	Spacer
B001	2578257022	Lid	B100	2578055010	Collar	B513	2578056010	Buffer
B003	2578105502	Chassis K	B105	2578101030	Support	B517	2578053022	Cover
B004	2578105012	Chassis	B106	2578101030	Support	B518	2578053030	Cover
B005	2578160012	Bracket	B107	2578101030	Support	B522	2579118010	Spacer
B006	2578160012	Bracket	B111	2578101040	Support	B523	2578118040	Spacer
						B524	2686118010	Spacer

REF. DESIG.	MARANTZ PART NO.	DESCRIPTION	REF. DESIG.	MARANTZ PART NO.	DESCRIPTION	REF. DESIG.	MARANTZ PART NO.	DESCRIPTION	REF. DESIG.	MARANTZ PART NO.	DESCRIPTION
D368	54050300R0	T. L. Washer OR	L101	LA10046200	Ant Coil	R510	RT108221140	820Ω ±10% 1/4W, Carbon Film	C510	DK17103010	0.01μF ±20% Cer.
D369	54050300R0	T. L. Washer OR	L102	LA10046160	RF Coil	R511	RT108221140	820Ω ±10% 1/4W, Carbon Film	C511	DD11050010	5pF ±0.5pF Cer.
D371	51122608E0	T. H. M. Screw	L103	LA10046190	RF Coil	R512	RT10332140	3.3KΩ ±10% 1/4W, Carbon Film	C512	DK17103010	0.01μF ±20% Cer.
D372	51122608E0	T. H. M. Screw	L104	LO12026020	OSC Coil	R513	RT10332140	3.3KΩ ±10% 1/4W, Carbon Film	C513	DK17103010	0.01μF ±20% Cer.
D373	51122608E0	T. H. M. Screw	L105	LI114016190	IFT	R514	RT10562140	5.6KΩ ±10% 1/4W, Carbon Film	C514	DK17103010	0.01μF ±20% Cer.
D374	51122608E0	T. H. M. Screw	L106	LC13020010	Choke Coil	R515	RNI10105140	1MΩ ±10% 1/4W, Carbon Film	C515	DK17103010	0.01μF ±20% Cer.
D377	54020401S0	Flat Washer S	L107	LC13020010	Choke Coil	R516	RT10222140	2.2KΩ ±10% 1/4W, Carbon Film	C516	DK17103010	0.01μF ±20% Cer.
D378	54020401S0	Flat Washer S	L108	LC13020010	Choke Coil	R517	RT10562140	5.6KΩ ±10% 1/4W, Carbon Film	C517	DK17103010	0.01μF ±20% Cer.
D379	54020401S0	Flat Washer S	L109	LC13020010	Choke Coil	R518	RT10104140	100KΩ ±10% 1/4W, Carbon Film	C518	DK17103010	0.01μF ±20% Cer.
D380	54020401S0	Flat Washer S	L110	HF200191A0	2SK19Y Transistor	R520	RT10472140	4.7KΩ ±10% 1/4W, Carbon Film	C520	ED47501020	4.7μF ±10V Elect.
D382	54020401E0	Flat Washer P	T101	2578109040	Shield	R521	RT10222140	6.8KΩ ±10% 1/4W, Carbon Film	C521	DD16201010	200pF ±10% Cer.
D383	54020401E0	Flat Washer P	T102	2578109040	Shield	R522	RT10682140	6.8KΩ ±10% 1/4W, Carbon Film	C522	DD16201010	200pF ±10% Cer.
D384	54020401E0	Flat Washer P	H101	HF200191A0	2SK19Y Transistor	R523	RT10682140	6.8KΩ ±10% 1/4W, Carbon Film	C523	ED47501020	4.7μF ±10V Elect.
D385	54020401E0	Flat Washer P	H102	HF200191B0	2SK19GN Transistor	R524	RT10153140	15KΩ ±10% 1/4W, Carbon Film	C524	ED47501020	4.7μF ±10V Elect.
D387	51060312E9	P. H. M. Screw	H103	HT308291B0	2SC829B Transistor	R525	RT10153140	15KΩ ±10% 1/4W, Carbon Film	C525	DF17473010	0.0047μF ±5% Mylar
D388	51060312E9	P. H. M. Screw	H104	HD10001050	1N60 Diode	R526	RT10562140	5.6KΩ ±10% 1/4W, Carbon Film	C526	DF55472010	0.0047μF ±5% Mylar
D389	51060312E9	P. H. M. Screw	H105	HD10001050	1N60 Diode	R527	RT10562140	5.6KΩ ±10% 1/4W, Carbon Film	C527	DF55472010	0.0047μF ±5% Mylar
D390	51060312E9	P. H. M. Screw	W101	YW27630010	Wire Materials	R528	RT10223140	22KΩ ±10% 1/4W, Carbon Film	C528	DF54122010	0.0012μF ±2% Mylar
D391	51060312E9	P. H. M. Screw	P200	YD25780020	PC Board	R529	RT10332140	3.3KΩ ±10% 1/4W, Carbon Film	C529	ED33501630	3.3μF ±10V Elect.
D392	51060312E9	P. H. M. Screw	R201	RT10562140	56KΩ ±10% 1/4W, Carbon Film	R530	RT10103140	10KΩ ±10% 1/4W, Carbon Film	C530	DF16332010	0.0033μF ±10% Mylar
D393	51060312E9	P. H. M. Screw	R202	RT10154140	150KΩ ±10% 1/4W, Carbon Film	R531	RT10821140	820Ω ±10% 1/4W, Carbon Film	C531	DF16332010	0.0033μF ±10% Mylar
D394	51060312E9	P. H. M. Screw	R203	RT10122140	1.2KΩ ±10% 1/4W, Carbon Film	R532	RT10221140	220Ω ±10% 1/4W, Carbon Film	C532	DK17103010	0.01μF ±20% Cer.
P100	YD25780130	PC Board	R204	RT10221140	220Ω ±10% 1/4W, Carbon Film	R533	RT10221140	220Ω ±10% 1/4W, Carbon Film	C533	ED47501020	4.7μF ±10V Elect.
R101	RC10104120	100KΩ ±10% 1/4W, Solid	R205	RT10823140	82KΩ ±10% 1/4W, Carbon Film	R534	RT10123140	12KΩ ±10% 1/4W, Carbon Film	C534	ED47501020	4.7μF ±10V Elect.
R102	RC10105120	1MΩ ±10% 1/4W, Solid	R206	RT10333140	33KΩ ±10% 1/4W, Carbon Film	R535	RT10123140	12KΩ ±10% 1/4W, Carbon Film	C535	DF65821010	820pF ±5% Mylar
R103	RC10221120	220Ω ±10% 1/4W, Solid	R207	RT10333140	33KΩ ±10% 1/4W, Carbon Film	R536	RT10221140	220Ω ±10% 1/4W, Carbon Film	C536	DF65821010	820pF ±5% Mylar
R104	RC10103120	10KΩ ±10% 1/4W, Solid	R208	RT10122140	1.2KΩ ±10% 1/4W, Carbon Film	R537	RT10221140	220Ω ±10% 1/4W, Carbon Film	C537	DF16332010	0.0033μF ±10% Mylar
R105	RC10103120	10KΩ ±10% 1/4W, Solid	R209	RT10333140	33KΩ ±10% 1/4W, Carbon Film	R538	RT10220140	220Ω ±10% 1/4W, Carbon Film	C538	DF16332010	0.0033μF ±10% Mylar
R106	RC10122120	1.2KΩ ±10% 1/4W, Solid	R210	RT10122140	220Ω ±10% 1/4W, Carbon Film	R539	RT10562140	5.6KΩ ±10% 1/4W, Carbon Film	C539	DF16332010	0.0033μF ±10% Mylar
R107	RC10221120	220Ω ±10% 1/4W, Solid	C201	DK17103010	0.01μF ±20% Cer.	R540	RT10104140	100KΩ ±10% 1/4W, Carbon Film	C540	DF16332010	0.0033μF ±10% Mylar
R108	RC10472120	4.7KΩ ±10% 1/4W, Solid	C202	DK17103010	0.01μF ±20% Cer.	R541	RT10563140	56KΩ ±10% 1/4W, Carbon Film	C541	DF16682010	0.0068μF ±20% Mylar
R109	RC10102120	1KΩ ±10% 1/4W, Solid	C203	DD16150010	15pF ±10% Cer.	R542	RT10104140	100KΩ ±10% 1/4W, Carbon Film	C542	DK17103010	0.01μF ±20% Cer.
R110	RC10223120	22KΩ ±10% 1/4W, Solid	C204	DK18403010	0.04μF +100% -0% Cer.	R543	RT10222140	2.2KΩ ±10% 1/4W, Carbon Film	C543	DK17103010	0.01μF ±20% Cer.
R111	RC10223120	22KΩ ±10% 1/4W, Solid	C205	DK18403010	0.04μF +100% -0% Cer.	R544	RT10154140	150KΩ ±10% 1/4W, Carbon Film	C544	DK17103010	0.0068μF ±20% Mylar
R111	CA40000010	FM 4Gang Variable with Trimmer	C206	DK17103010	0.01μF ±20% Cer.	R545	RT10562140	5.6KΩ ±10% 1/4W, Carbon Film	C545	DK17103010	0.01μF ±20% Cer.
C104	CT11000020	2.8pF -12.8pF Trimmer	C207	DD16200010	20pF ±10% Cer.	R546	RT10562140	5.6KΩ ±10% 1/4W, Carbon Film	C546	DK17103010	0.01μF ±20% Cer.
C105	DD16150010	15pF ±10% Cer.	C208	DD16200010	20pF ±10% Cer.	R547	RT10102140	1KΩ ±10% 1/4W, Carbon Film	C547	DD16201010	200pF ±10% Cer.
C106	DK17102010	0.001μF ±20% Cer.	C209	DF65391500	390pF ±5% Mylar	R548	RT10123140	1.2KΩ ±10% 1/4W, Carbon Film	C548	DK17103010	0.01μF ±20% Cer.
C107	DK17102010	0.001μF ±20% Cer.	C210	DK18403010	0.04μF ±100% -0% Cer.	R549	RT10103140	10KΩ ±10% 1/4W, Carbon Film	C549	DK17103010	0.01μF ±20% Cer.
C108	DD16008010	0.8pF ±10% Cer.	C211	EA10601620	10μF ±100% -0% Cer.	R550	RT10103140	10KΩ ±10% 1/4W, Carbon Film	C550	DK17103010	0.01μF ±20% Cer.
C109	DD16150010	15pF ±10% Cer.	L202	LO10010350	RF Coil	R551	RT10221140	220Ω ±10% 1/4W, Carbon Film	C551	EV22402510	0.2μF ±20% Cer.
C110	CT11000020	2.8pF -12.8pF Trimmer	L203	LI14010010	OSC Coil	R552	RT10221140	220Ω ±10% 1/4W, Carbon Film	C552	EA10700610	100μF ±3V Elect.
C111	DK17102010	0.001μF ±20% Cer.	H201	HT303711B0	2SC371 Transistor	R553	RT10562140	5.6KΩ ±10% 1/4W, Carbon Film	C553	DK18403010	0.04μF ±100% -0% Cer.
C112	CT11000020	2.8pF -12.8pF Trimmer	H202	HT303711A0	2SC371 Transistor	R554	RT10562140	5.6KΩ ±10% 1/4W, Carbon Film	C554	DK17103010	0.01μF ±20% Cer.
C113	DD16200010	2.0μF ±10% Cer.	H203	HDI10001050	1N60 Diode	R555	RT10332140	3.3KΩ ±10% 1/4W, Carbon Film	C555	DK17103010	0.01μF ±20% Cer.
C114	DK17103010	0.01μF ±20% Cer.	J201	YP10000360	Plug	R556	RT10224140	220KΩ ±10% 1/4W, Carbon Film	C556	DK18403010	0.04μF ±100% -0% Cer.
C115	DD16150030	15pF ±10% CH Cer.	J202	YP10000360	Plug	R557	RT10223140	3.3KΩ ±10% 1/4W, Carbon Film	C557	EA47501610	4.7μF ±16V Elect.
C116	DD12100060	10pF ±10% CH Cer.	J203	YP10000360	Plug	R558	RT10474140	470KΩ ±10% 1/4W, Carbon Film	C558	DK18403010	0.04μF +100% -0% Cer.
C117	DK17103010	0.01μF ±20% Cer.	J204	YP10000360	Plug	R559	RT10153140	15KΩ ±10% 1/4W, Carbon Film	C559	EA47501610	4.7μF ±16V Elect.
C118	DD16150060	15pF ±10% PH Cer.	J205	YP10000360	Plug	R560	RT10153140	15KΩ ±10% 1/4W, Carbon Film	C560	DK18403010	0.04μF +100% -0% Cer.
C119	CT10500010	1 -5pF CH Trimmer	J206	YP10000360	Plug	R561	RT10101140	100Ω ±10% 1/4W, Carbon Film	C561	DD15301010	300pF ±5% Cer.
C120	DD12100060	10pF ±1pF CH Cer.	J207	YP10000360	Plug	R562	RC10223120	22KΩ ±10% 1/4W, Solid	C562	DK17502010	0.005μF ±20% Cer.
C121	DK17102010	0.001μF ±20% Cer.	J208	YD25780050	PC Board	R563	RT10104140	100KΩ ±10% 1/4W, Carbon Film	C563	DK17502010	0.005μF ±20% Cer.
C122	DK17103010	0.01μF ±20% Cer.	P500	YD25780050	PC Board	R564	RT10821140	820Ω ±10% 1/4W, Carbon Film	C564	DK18403010	0.04μF ±100% -0% Cer.
C123	DK17103010	0.01μF ±20% Cer.	R501	RT10222140	2.2KΩ ±10% 1/4W, Carbon Film	R565	RT10103140	10KΩ ±10% 1/4W, Carbon Film	C565	DF17473010	0.0047μF ±20% Mylar
C124	DD12100010	10pF ±1pF Cer.	R502	RT10331140	330Ω ±10% 1/4W, Carbon Film	R566	RT10103140	10KΩ ±10% 1/4W, Carbon Film	C566	DK18403010	0.04μF +100% -0% Cer.
C125	DK17103010	0.01μF ±20% Cer.	R503	RT10331140	330Ω ±10% 1/4W, Carbon Film	R567	RT10104140	100KΩ ±10% 1/4W, Carbon Film	C567	DF17473010	0.0047μF ±20% Mylar
C004	DC11030020	3pF ±0.5pF Feed Through	R504	RT10271140	270Ω ±10% 1/4W, Carbon Film	R568	DK17103010	0.01μF ±20% Cer.	C568	EA10601620	10μF ±16V Elect.
C003	DC18102010	0.001μF ±100% -0% Feed Through	R505	RT10331140	330Ω ±10% 1/4W, Carbon Film	R569	DK17103010	0.01μF ±20% Cer.	C569	ED10601020	10μF ±10V Elect.
C128	DK17102010	0.001μF ±20% Cer.	R506	RT10331140	330Ω ±10% 1/4W, Carbon Film	C505	DK17103010	0.01μF ±20% Cer.	C571	DK18403010	0.04μF +100% -0% Cer.
C129	DD10010010	1.0pF ±0.25pF Cer.	R507	RT10271140	270Ω ±10% 1/4W, Carbon Film	C506	DK17103010	0.01μF ±20% Cer.	C575	DD16501010	500pF ±10% Cer.
C130	DK17103010	0.01μF ±0.5pF CH Cer.	R508	RT10272140	2.7KΩ ±10% 1/4W, Carbon Film	C507	DK17103010	0.01μF ±20% Cer.	C576	EA22701640	220μF ±16V Elect.
C131	DD11020040	2pF ±0.5pF CH Cer.	R509	RT10101140	100Ω ±10% 1/4W, Carbon Film	C508	DK17103010	0.01μF ±20% Cer.	C577	DK17103010	0.01μF ±20% Cer.

MARANTZ

REF. DESIG.	MARANTZ PART NO.	DESCRIPTION	REF. DESIG.	MARANTZ PART NO.	DESCRIPTION
C578	DK18203010	0.02 μ F +100% -0% Cer.	J523	YP10000360	Plug
C579	EA22701620	220 μ F 16V Elect.	J525	YP10000010	Plug
L502	LC12230010	22 μ H Choke Coil	J526	YP10000010	Plug
L503	LC12230010	22 μ H Choke Coil	J527	YP10000010	Plug
L504	LC12230010	22 μ H Choke Coil	J528	YP10000010	Plug
L505	LC12230010	22 μ H Choke Coil	W501	YW27630022	Wire Materials
L506	LC12230010	22 μ H Choke Coil	P700	YD25780140	PC Board
L507	LI14016043	FM IFT (Det)	R701	RT10474140	470K Ω \pm 10% $\frac{1}{4}$ W, Carbon Film
L508	LI10156010	FM IFT (Sub)	R702	RT10562140	5.6K Ω \pm 10% $\frac{1}{4}$ W, Carbon Film
L509	LI10156020	FM IFT (Sub)	R703	RT10102140	1K Ω \pm 10% $\frac{1}{4}$ W, Carbon Film
L510	LI14010040	AM IFT	R704	RT10682140	6.8K Ω \pm 10% $\frac{1}{4}$ W, Carbon Film
L511	LI14010050	AM IFT	R711	RN10474140	470K Ω \pm 10% $\frac{1}{4}$ W, Carbon Film
L512	LS10010070	19KHz MPX Coil	R712	RN10474140	470K Ω \pm 10% $\frac{1}{4}$ W, Carbon Film
L513	LS10010070	19KHz MPX Coil	R713	RN10154140	150K Ω \pm 10% $\frac{1}{4}$ W, Carbon Film
L514	LS10010070	38KHz MPX Coil	R714	RN10154140	150K Ω \pm 10% $\frac{1}{4}$ W, Carbon Film
L515	LS10010060	38KHz Trap Coil	R715	RN10223140	22K Ω \pm 10% $\frac{1}{4}$ W, Carbon Film
L516	LS10010060	38KHz Trap Coil	R716	RN10223140	22K Ω \pm 10% $\frac{1}{4}$ W, Carbon Film
L517	LS10010060	19KHz Trap Coil	R717	RT10562140	5.6K Ω \pm 10% $\frac{1}{4}$ W, Carbon Film
L518	LS10010060	19KHz Trap Coil	R718	RT10562140	5.6K Ω \pm 10% $\frac{1}{4}$ W, Carbon Film
L519	LI10016160	FM IFT	R719	RT10102140	5.6K Ω \pm 10% $\frac{1}{4}$ W, Carbon Film
F501	FF11070010	SFC 10.7MA Ceramic Filter	R720	RT10102140	5.6K Ω \pm 10% $\frac{1}{4}$ W, Carbon Film
F502	FF11070010	SFC 10.7MA Ceramic Filter	R721	RT10153140	15K Ω \pm 10% $\frac{1}{4}$ W, Carbon Film
H501	HC10001110	μ A703 IC	R722	RT10153140	15K Ω \pm 10% $\frac{1}{4}$ W, Carbon Film
H502	HC10001140	CA3011 IC	R723	RT10562140	5.6K Ω \pm 10% $\frac{1}{4}$ W, Carbon Film
H503	HC10001140	CA3011 IC	R725	RT10224140	220K Ω \pm 10% $\frac{1}{4}$ W, Carbon Film
H504	HT306441B0	2SC644S Transistor	R726	RT10224140	220K Ω \pm 10% $\frac{1}{4}$ W, Carbon Film
H505	HC10001170	MC1304P IC	C701	DF17224020	0.22 μ F \pm 20% 50V Mylar
H506	HT303801B0	2SC380O Transistor	C702	DF17224020	0.22 μ F \pm 20% 50V Mylar
H507	HT303801B0	2SC380O Transistor	C703	EA10603510	10 μ F \pm 20% 35V Elect.
H508	HT30372100	2SC372 Transistor	C704	EA10603510	10 μ F \pm 20% 35V Elect.
H509	HT104951A0	2SA495 Transistor	C705	EA10702520	100 μ F \pm 20% 25V Elect.
H510	HT303711B0	2SC371 Transistor	C706	EM47402510	0.47 μ F \pm 20% 25V Elect.
H511	HT303711A0	2SC371 Transistor	C707	EM47402510	0.47 μ F \pm 20% 25V Elect.
H513	HD10001050	1N60 Diode	C708	DF17104020	0.1 μ F \pm 20% 50V Mylar
H514	HD10001050	1N60 Diode	C709	EA10601620	10 μ F \pm 20% 16V Elect.
H515	HD10001010	1N34A Diode	C710	EA47405010	0.47 μ F \pm 20% 50V Elect.
H516	HD10001010	1N34A Diode	C711	DK17103010	0.01 μ F \pm 20% Cer.
H517	HD10001050	1N60 Diode	H701	HT30372100	2SC372 Transistor
H518	HD10001050	1N60 Diode	H705	HT304582A0	2SC458LG \odot or \odot Transistor
H520	HD10001050	1N60 Diode	H706	HT304582A0	2SC458LG \odot or \odot Transistor
H521	HD10001050	1N60 Diode	H707	HT104942A0	2SA494 (Y or GR) Transistor
J501	YP10000360	Plug	H708	HT104942A0	2SA494 (Y or GR) Transistor
J502	YP10000360	Plug	H709	HD10001050	1N60 Diode
J503	YP10000360	Plug	J701	YP10000360	Plug
J504	YP10000360	Plug	J702	YP10000360	Plug
J505	YP10000360	Plug	J703	YP10000360	Plug
J506	YP10000360	Plug	J704	YP10000360	Plug
J507	YP10000360	Plug	J707	YP10000360	Plug
J508	YP10000360	Plug	J708	YP10000360	Plug
J509	YP10000360	Plug	J709	YP10000360	Plug
J510	YP10000360	Plug	J710	YP10000360	Plug
J511	YP10000360	Plug	J711	YP10000360	Plug
J512	YP10000360	Plug	J712	YP10000360	Plug
J513	YP10000360	Plug	J713	YP10000360	Plug
J514	YP10000360	Plug	P300	YD25770030	Phono Amp. PC Board
J515	YP10000360	Plug	R301	RN10473140	47K Ω \pm 10% $\frac{1}{4}$ W, Carbon Film
J516	YP10000360	Plug	R302	RN10473140	47K Ω \pm 10% $\frac{1}{4}$ W, Carbon Film
J517	YP10000360	Plug	R303	RT10391140	390 Ω \pm 10% $\frac{1}{4}$ W, Carbon Film
J518	YP10000360	Plug	R304	RT10391140	390 Ω \pm 10% $\frac{1}{4}$ W, Carbon Film
J519	YP10000360	Plug	R305	RN10105140	1M Ω \pm 10% $\frac{1}{4}$ W, Carbon Film
J520	YP10000360	Plug	R306	RN10105140	1M Ω \pm 10% $\frac{1}{4}$ W, Carbon Film
J521	YP10000360	Plug	R307	GT05202120	2K Ω \pm 5% $\frac{1}{2}$ W, Carbon Film
J522	YP10000360	Plug	R308	GT05202120	2K Ω \pm 5% $\frac{1}{2}$ W, Carbon Film

REF. DESIG.	MARANTZ PART NO.	DESCRIPTION	REF. DESIG.	MARANTZ PART NO.	DESCRIPTION
R309	GT05185120	1.8M Ω \pm 5 % $\frac{1}{2}$ W, Carbon Film	R424	RN10683140	68K Ω \pm 10% $\frac{1}{4}$ W, Carbon Film
R310	GT05185120	1.8M Ω \pm 5 % $\frac{1}{2}$ W, Carbon Film	R425	RN10683140	68K Ω \pm 10% $\frac{1}{4}$ W, Carbon Film
R311	GT05154120	150K Ω \pm 5 % $\frac{1}{2}$ W, Carbon Film	R426	RT10103140	10K Ω \pm 10% $\frac{1}{4}$ W, Carbon Film
R312	GT05154120	150K Ω \pm 5 % $\frac{1}{2}$ W, Carbon Film	R427	RT10103140	10K Ω \pm 10% $\frac{1}{4}$ W, Carbon Film
R313	RN10104140	100K Ω \pm 10% $\frac{1}{4}$ W, Carbon Film	R428	RT10103140	10K Ω \pm 10% $\frac{1}{4}$ W, Carbon Film
R314	RN10104140	100K Ω \pm 10% $\frac{1}{4}$ W, Carbon Film	R429	RT10103140	10K Ω \pm 10% $\frac{1}{4}$ W, Carbon Film
R315	RT10103140	10K Ω \pm 10% $\frac{1}{4}$ W, Carbon Film	R430	RT10221140	220 Ω \pm 10% $\frac{1}{4}$ W, Carbon Film
R316	RN10153140	15K Ω \pm 10% $\frac{1}{4}$ W, Carbon Film	R431	RT10221140	220 Ω \pm 10% $\frac{1}{4}$ W, Carbon Film
R317	RN10153140	15K Ω \pm 10% $\frac{1}{4}$ W, Carbon Film	R432	RN10104140	100K Ω \pm 10% $\frac{1}{4}$ W, Carbon Film
R318	RT10152140	1.5K Ω \pm 10% $\frac{1}{4}$ W, Carbon Film	R433	RN10104140	100K Ω \pm 10% $\frac{1}{4}$ W, Carbon Film
R319	RT10152140	1.5K Ω \pm 10% $\frac{1}{4}$ W, Carbon Film	C401	DF17224020	0.22 μ F 50V \pm 20% Elect.
R320	RT10561140	560 Ω \pm 10% $\frac{1}{4}$ W, Carbon Film	C402	DF17224020	0.22 μ F 50V \pm 20% Elect.
R321	RT10561140	560 Ω \pm 10% $\frac{1}{4}$ W, Carbon Film	C403	EV22502510	2.2 μ F 25V \pm 40% -20% Elect.
R322	RT10221140	220 Ω \pm 10% $\frac{1}{4}$ W, Carbon Film	C404	EV22502510	2.2 μ F 25V \pm 40% -20% Elect.
R323	RN10334140	330K Ω \pm 10% $\frac{1}{4}$ W, Carbon Film	C405	EA22603510	22 μ F 25V Elect.
R324	RN10334140	330K Ω \pm 10% $\frac{1}{4}$ W, Carbon Film	C406	EA22603510	22 μ F 35V Elect.
C301	EV22502510	2.2 μ F 25V \pm 40% -20% Elect.	C407	EV22502510	2.2 μ F 25V \pm 40% -20% Elect.
C302	EV22502510	2.2 μ F 25V \pm 40% -20% Elect.	C408	EV22502510	2.2 μ F 25V \pm 40% -20% Elect.
C303	EA22603510	22 μ F 35V \pm 100% -0% Elect.	C409	EA10703510	100 μ F 35V Elect.
C304	DF65182010	1800pF 50V \pm 5 % Mylar	C410	EV22502510	2.2 μ F 25V \pm 40% -20% Elect.
C305	DF65182010	1800pF 50V \pm 5 % Mylar	C411	EV22502510	2.2 μ F 25V \pm 40% -20% Elect.
C308	EA10700610	100 μ F 6.3V \pm 100% -0% Elect.	C412	DF65451010	450pF \pm 5 % Mylar
C309	EA10700610	100 μ F 6.3V \pm 100% -0% Elect.	C413	DF65451010	450pF \pm 5 % Mylar
C310	EV10503510	1 μ F 35V \pm 40% -20% Elect.	C414	EV10502520	1 μ F 25V \pm 40% -20% Elect.
C311	EV10503510	1 μ F 35V \pm 40% -20% Elect.	C415	EV10502520	1 μ F 25V \pm 40% -20% Elect.
C312	EA10705010	100 μ F 50V Elect.	H401	HT304580Z0	2SC458 LG \odot Transistor
C316	DF65501010	500pF 50V \pm 5 % Mylar	H402	HT304580Z0	2SC458 LG \odot Transistor
C317	DF65501010	500pF 50V \pm 5 % Mylar	H403	HT104942A0	2SA494 (Y or GR) Transistor
H301	HT306441C0	2SC644(T) Transistor	H404	HT104942A0	2SA494 (Y or GR) Transistor
H302	HT306441C0	2SC644(T) Transistor	H405	HT307321B0	2SC732 (BL) Transistor
H303	HF200301C0	2SK30 (Y) Transistor	H406	HT307321B0	2SC732 (BL) Transistor
H304	HF200301C0	2SK30 (Y) Transistor	H407	HT104942A0	2SA494 (Y or GR) Transistor
J301	YP10000360	Plug	H408	HT104942A0	2SA494 (Y or GR) Transistor
J302	YP10000360	Plug	J401	YP10000360	Plug
J303	YP10000360	Plug	J402	YP10000360	Plug
J304	YP10000360	Plug	J403	YP10000360	Plug
J305	YP10000360	Plug	J404	YP10000360	Plug
J306	YP10000360	Plug	J405	YP10000360	Plug
J307	YP10000360	Plug	J406	YP10000360	Plug
P400	YD25770040	Tone Amp. PC Board	J407	YP10000360	Plug
R401	RT10391140	390 Ω \pm 10% $\frac{1}{4}$ W, Carbon Film	J408	YP10000360	Plug
R402	RT10391140	390 Ω \pm 10% $\frac{1}{4}$ W, Carbon Film	J409	YP10000360	Plug
R403	RN10473140	47K Ω \pm 10% $\frac{1}{4}$ W, Carbon Film	J410	YP10000360	Plug
R404	RN10473140	47K Ω \pm 10% $\frac{1}{4}$ W, Carbon Film	J411	YP10000360	Plug
R405	RN10563140	56K Ω \pm 10% $\frac{1}{4}$ W, Carbon Film	J412	YP10000360	Plug
R406	RN10563140	56K Ω \pm 10% $\frac{1}{4}$ W, Carbon Film	J413	YP10000360	Plug
R407	RT05682140	6.8K Ω \pm 5 % $\frac{1}{4}$ W, Carbon Film	J414	YP10000360	Plug
R408	RT05682140	6.8K Ω \pm 5 % $\frac{1}{4}$ W, Carbon Film	J415	YP10000360	Plug
R409	RN10223140	22K Ω \pm 10% $\frac{1}{4}$ W, Carbon Film	J416	YP10000360	Plug
R410	RN10223140	22K Ω \pm 10% $\frac{1}{4}$ W, Carbon Film	J418	YP10000360	Plug
R411	RT05272140	2.7K Ω \pm 5 % $\frac{1}{4}$ W, Carbon Film	J419	YP10000360	Plug
R412	RT05272140	2.7K Ω \pm 5 % $\frac{1}{4}$ W, Carbon Film	J420	YP10000360	Plug
R413	RT10102140	1K Ω \pm 5 % $\frac{1}{4}$ W, Carbon Film	W401	YW27630030	Wire Materials
R414	RT10102140	1K Ω \pm 10% $\frac{1}{4}$ W, Carbon Film	P600	YD25780060	Main Amp. PC Board
R415	RN10153140	15K Ω \pm 10% $\frac{1}{4}$ W, Carbon Film	R601	RN10474140	470K Ω \pm 10% $\frac{1}{4}$ W, Carbon Film
R416	RN10153140	15K Ω \pm 10% $\frac{1}{4}$ W, Carbon Film	R602	RN10474140	470K Ω \pm 10% $\frac{1}{4}$ W, Carbon Film
R417	RT10681140	680 Ω \pm 10% $\frac{1}{4}$ W, Carbon Film	R603	GT05102120	1K Ω \pm 5 % $\frac{1}{2}$ W, Carbon Film
R418	RN10563140	56K Ω \pm 10% $\frac{1}{4}$ W, Carbon Film	R604	GT05102120	1K Ω \pm 5 % $\frac{1}{2}$ W, Carbon Film
R419	RN10563140	56K Ω \pm 10% $\frac{1}{4}$ W, Carbon Film	R605	RN10473140	47K Ω \pm 10% $\frac{1}{4}$ W, Carbon Film
R420	RT05223140	22K Ω \pm 5 % $\frac{1}{4}$ W, Carbon Film	R606	RN10473140	47K Ω \pm 10% $\frac{1}{4}$ W, Carbon Film
R421	RT05223140	22K Ω \pm 5 % $\frac{1}{4}$ W, Carbon Film	R607	GT02821120	820 Ω \pm 2 % $\frac{1}{2}$ W, Carbon Film
R422	RN10225140	2.2M Ω \pm 10% $\frac{1}{4}$ W, Carbon Film	R608	GT02821120	820 Ω \pm 2 % $\frac{1}{2}$ W, Carbon Film
R423	RN10225140	2.2M Ω \pm 10% $\frac{1}{4}$ W, Carbon Film			

REF. DESIG.	MARANTZ PART NO.	DESCRIPTION	REF. DESIG.	MARANTZ PART NO.	DESCRIPTION
R609	GT05104120	100K Ω \pm 5 % $\frac{1}{2}$ W, Carbon Film	H602	HC10002170	MC1741 (Motorola) IC
R610	GT05104120	100K Ω \pm 5 % $\frac{1}{2}$ W, Carbon Film	H603	HT105621B0	2SA562(O) Transistor
R611	GT05153120	15K Ω \pm 5 % $\frac{1}{2}$ W, Carbon Film	H604	HT105621B0	2SA562(O) Transistor
R612	GT05153120	15K Ω \pm 5 % $\frac{1}{2}$ W, Carbon Film	H605	HT303711B0	2SC371(O) Transistor
R613	GT05103120	10K Ω \pm 5 % $\frac{1}{2}$ W, Carbon Film	H606	HT303711B0	2SC371(O) Transistor
R614	GT05103120	10K Ω \pm 5 % $\frac{1}{2}$ W, Carbon Film	H607	HT104972B0	2SA497(R or O) Transistor
R615	RA02020030	2K Ω B Semi Fixed	H608	HT104972B0	2SA497(R or O) Transistor
R616	RA02020030	2K Ω B Semi Fixed	H609	HT104972A0	2SA497(O or Y) Transistor
R617	GT05912120	9.1K Ω \pm 5 % $\frac{1}{2}$ W, Carbon Film	H610	HT104972A0	2SA497(O or Y) Transistor
R618	GT05912120	9.1K Ω \pm 5 % $\frac{1}{2}$ W, Carbon Film	H611	HT304972B0	2SC497(R or O) Transistor
R619	RC10182120	1.8K Ω \pm 10% $\frac{1}{2}$ W, Solid	H612	HT304972B0	2SC497(R or O) Transistor
R620	RC10182120	1.8K Ω \pm 10% $\frac{1}{2}$ W, Solid	H613	HT304972A0	2SC497(O or Y) Transistor
R621	RT10821140	820 Ω \pm 10% $\frac{1}{4}$ W, Carbon Film	H614	HT304972A0	2SC497(O or Y) Transistor
R622	RT10821140	820 Ω \pm 10% $\frac{1}{4}$ W, Carbon Film	H615	HD30011090	1S198 Diode
R623	RC10182120	1.8K Ω \pm 10% $\frac{1}{2}$ W, Solid	H616	HD30011090	1S198 Diode
R624	RC10182120	1.8K Ω \pm 10% $\frac{1}{2}$ W, Solid	H617	HD30011090	1S198 Diode
R625	GT05621120	620 Ω \pm 5 % $\frac{1}{2}$ W, Carbon Film	H618	HD30011090	1S198 Diode
R626	GT05621120	620 Ω \pm 5 % $\frac{1}{2}$ W, Carbon Film	H619	HV00007050	S3016-R Varistor
R627	GT05183120	18K Ω \pm 5 % $\frac{1}{2}$ W, Carbon Film	H620	HV00007050	S3016-R Varistor
R628	GT05183120	18K Ω \pm 5 % $\frac{1}{2}$ W, Carbon Film	H621	HV00007050	S3016-R Varistor
R629	GT05183120	18K Ω \pm 5 % $\frac{1}{2}$ W, Carbon Film	H622	HV00007050	S3016-R Varistor
R630	GT05183120	18K Ω \pm 5 % $\frac{1}{2}$ W, Carbon Film	J601	YP10000360	Plug
R631	GT05183120	18K Ω \pm 5 % $\frac{1}{2}$ W, Carbon Film	J602	YP10000360	Plug
R632	GT05183120	18K Ω \pm 5 % $\frac{1}{2}$ W, Carbon Film	J605	YP10000360	Plug
R633	GT05471120	470 Ω \pm 5 % $\frac{1}{2}$ W, Carbon Film	J606	YP10000360	Plug
R634	GT05471120	470 Ω \pm 5 % $\frac{1}{2}$ W, Carbon Film	J607	YP10000360	Plug
R635	RC10101120	100 Ω \pm 10% $\frac{1}{2}$ W, Solid	J608	YP10000360	Plug
R636	RC10101120	100 Ω \pm 10% $\frac{1}{2}$ W, Solid	J609	YP10000360	Plug
R637	RC10101120	100 Ω \pm 10% $\frac{1}{2}$ W, Solid	J610	YP10000360	Plug
R638	RC10101120	100 Ω \pm 10% $\frac{1}{2}$ W, Solid	J611	YP10000360	Plug
R639	GT05331120	330 Ω \pm 5 % $\frac{1}{2}$ W, Carbon Film	J612	YP10000360	Plug
R640	GT05331120	330 Ω \pm 5 % $\frac{1}{2}$ W, Carbon Film	J613	YP10000360	Plug
R641	GT05221120	220 Ω \pm 5 % $\frac{1}{2}$ W, Carbon Film	J614	YP10000360	Plug
R642	GT05221120	220 Ω \pm 5 % $\frac{1}{2}$ W, Carbon Film	J615	YP10000360	Plug
R643	GT05151120	150 Ω \pm 5 % $\frac{1}{2}$ W, Carbon Film	J616	YP10000360	Plug
R644	GT05151120	150 Ω \pm 5 % $\frac{1}{2}$ W, Carbon Film	J617	YP10000360	Plug
R645	GT05331120	330 Ω \pm 5 % $\frac{1}{2}$ W, Carbon Film	J618	YP10000360	Plug
R646	GT05331120	330 Ω \pm 5 % $\frac{1}{2}$ W, Carbon Film	J619	YP10000360	Plug
R647	RJ10101010	100 Ω \pm 10% 1 W, Solid	J620	YP10000360	Plug
R648	RJ10101010	100 Ω \pm 10% 1 W, Solid	J621	YP10000360	Plug
R649	RJ10101010	100 Ω \pm 10% 1 W, Solid	J622	YP10000360	Plug
R650	RJ10101010	100 Ω \pm 10% 1 W, Solid	J624	YP10000360	Plug
R651	GW10202050	0.2 Ω \pm 10% 5 W, Carbon Film	J625	YP10000360	Plug
R652	GW10202050	0.2 Ω \pm 10% 5 W, Wire Wound	J626	YP10000360	Plug
R653	GW10202050	0.2 Ω \pm 10% 5 W, Wire Wound	J627	YP10000360	Plug
R654	GW10202050	0.2 Ω \pm 10% 5 W, Wire Wound	T601	1988267030	Heat Sink
C601	DF27105500	1 μ F \pm 20% 100V Mylar	T602	1988267030	Heat Sink
C602	DF27105500	1 μ F \pm 20% 100V Mylar	T603	1988267030	Heat Sink
C603	DF36101520	100pF \pm 10% 500V Mylar	T604	1988267030	Heat Sink
C604	DF36101520	100pF \pm 10% 500V Mylar	T605	1988267030	Heat Sink
C605	EA10701630	100 μ F 16V Elect.	T606	1988267030	Heat Sink
C606	EA10701630	100 μ F 16V Elect.	T607	1988267030	Heat Sink
C607	EA10701630	100 μ F 16V Elect.	T608	1988267030	Heat Sink
C608	EA10701630	100 μ F 16V Elect.	T609	2577118060	Spacer
C609	DF17104510	0.1 μ F \pm 20% 100V Mylar	T610	2577118060	Spacer
C610	DF17104510	0.1 μ F \pm 20% 100V Mylar	T611	2577118060	Spacer
C611	DF17104510	0.1 μ F \pm 20% 100V Mylar	T612	2577118060	Spacer
C612	DF17104510	0.1 μ F \pm 20% 100V Mylar	T613	2577118060	Spacer
C615	DF17224020	0.22 μ F \pm 20% 100V Mylar	T614	2577118060	Spacer
C616	DF17224020	0.22 μ F \pm 20% 100V Mylar	T615	2577118060	Spacer
C620	DK18103510	0.01 μ F 500V +100% -0% Cer.	T616	2577118060	Spacer
C621	DK18103510	0.01 μ F 500V +100% -0% Cer.	P800	YD25780150	Power Supply PC Board
H601	HC10002170	MC1741 (Motorola) IC	T801	2577118060	Spacer

REF. DESIG.	MARANTZ PART NO.	DESCRIPTION	REF. DESIG.	MARANTZ PART NO.	DESCRIPTION
R801	RW10470020	47Ω ±10% 2 W, Wire Wound	P920	YD25780030	Switch PC Board
R802	RC10100120	10Ω ±10% ½W, Solid	R920	RT10102140	1KΩ ±10% ¼W, Carbon Film
R803	RC10272120	2.7KΩ ±10% ½W, Solid	R922	RT10102140	1KΩ ±10% ¼W, Carbon Film
R804	RC10102120	1KΩ ±10% ½W, Solid	R923	RT10102140	1KΩ ±10% ¼W, Carbon Film
R805	RC10472120	4.7KΩ ±10% ½W, Solid	R924	RT10102140	1KΩ ±10% ¼W, Carbon Film
R806	RC10472120	4.7KΩ ±10% ½W, Solid	S921	SP04030012	Push Switch.
R807	RC10102120	1KΩ ±10% ½W, Solid			S920-1, Tape Moni, S920-2, Mono "L" S920-3, Mono "R"
R808	RC10332120	3.3KΩ ±10% ½W, Solid	J921	YP10000360	Plug
R809	RC10222120	2.2KΩ ±10% ½W, Solid	J922	YP10000360	Plug
R810	RC10153120	15KΩ ±10% ½W, Solid	J923	YP10000360	Plug
R811	RA03020010	3KΩ B Semi Fixed	W921	YW27630040	Wire Materials
R812	RA01030010	10KΩ B Semi Fixed	P940	YD25780100	Tone-Control PC Board
R813	RC10272120	2.7KΩ ±10% ½W, Solid	R941	RD01040010	100KΩ B Treble, Variable
R814	RC10100120	10Ω ±10% ½W, Solid	R942	RD01040010	100KΩ B Bass, Variable
C801	EB10805010	1000μF 50V Elect.	R943	GT05163120	16KΩ ±5% ½W, Carbon Film
C802	EB10805010	1000μF 50V Elect.	R944	GT05163120	16KΩ ±5% ½W, Carbon Film
C803	EA47603520	47μF 35V Elect.	R945	GT05163120	16KΩ ±5% ½W, Carbon Film
C804	EA33705020	330μF 50V Elect.	R946	GT05163120	16KΩ ±5% ½W, Carbon Film
C805	EA10701630	100μF 16V Elect.	C941	DF16223010	0.022μF ±10% Mylar
C806	EA47605010	47μF 50V Elect.	C942	DF16223010	0.022μF ±10% Mylar
C807	EA10603510	10μF 35V Elect.	C943	DF16223010	0.022μF ±10% Mylar
H801	HT402343A0	2SD234 (R.O.Y) Transistor	C944	DF16223010	0.022μF ±10% Mylar
H802	HT306965A0	2SC696 (H.E.D.B.A) Transistor	J941	57219520W0	Lug Eyelet
H803	HT307341C0	2SC734 (Y) Transistor	J942	57219520W0	Lug Eyelet
H804	HT307341C0	2SC734 (Y) Transistor	J943	57219520W0	Lug Eyelet
H805	HD30003090	1S332 Diode	J944	57219520W0	Lug Eyelet
H806	HD30003090	1S332 Diode	J945	57219520W0	Lug Eyelet
H807	HD20001100	1S1665 Diode	J946	57219520W0	Lug Eyelet
J801	YP10000360	Plug	J947	57219520W0	Lug Eyelet
J802	YP10000360	Plug	J948	57219520W0	Lug Eyelet
J803	YP10000360	Plug	P960	YD25780070	Comp, Circuit PC Board
J804	YP10000360	Plug	R961	RA01020010	1KΩ B Semi Fixed
J805	YP10000360	Plug	R962	RA01020010	1KΩ B Semi Fixed
P900	YD25780090	Switch PC Board	H961	HD20003010	HR-5A Diode
R901	GT05472120	4.7KΩ ±5% ½W, Carbon Film	H962	HD20003010	HR-5A Diode
R902	GT05472120	4.7KΩ ±5% ½W, Carbon Film	H963	HV00007050	S3016-R Varistor
R903	GT05472120	4.7KΩ ±5% ½W, Carbon Film	H964	HD20003010	HR-5A Diode
R904	GT05472120	4.7KΩ ±5% ½W, Carbon Film	H965	HD20003010	HR-5A Diode
R905	GT05563120	56KΩ ±5% ½W, Carbon Film	H966	HV00007050	S3016-R Varistor
R906	GT05563120	56KΩ ±5% ½W, Carbon Film	H967	HT304580K0	2SC458 (LB) Transistor
R907	RN10105140	1MΩ ±10% ¼W, Carbon Film	H968	HT304580K0	2SC458 (LB) Transistor
R908	RN10105140	1MΩ ±10% ¼W, Carbon Film	J961	57271240W0	Lug Eyelet
R909	RN10225140	2.2MΩ ±10% ¼W, Carbon Film	J962	57271240W0	Lug Eyelet
R910	RN10225140	2.2MΩ ±10% ¼W, Carbon Film	J963	57271240W0	Lug Eyelet
R911	RT10103140	10KΩ ±10% ¼W, Carbon Film	J964	57271240W0	Lug Eyelet
R912	RT10103140	10KΩ ±10% ¼W, Carbon Film	H001	HT70004100	SJ2001 (PNP) Transistor
R913	RT10154140	150KΩ ±10% ¼W, Carbon Film	H002	HT70004100	SJ2001 (PNP) Transistor
R914	RT10154140	150KΩ ±10% ¼W, Carbon Film	H003	HT90004100	SJ2000 (NPN) Transistor
C901	DF55472010	4700pF ±5% Mylar	H004	HT90004100	SJ2000 (NPN) Transistor
C902	DF16683010	0.068μF ±10% Mylar	H005	HD20004050	M9235F Diode
C903	DF16683010	0.068μF ±10% Mylar	H006	HD20005050	M9235A Diode
C904	DF16683010	0.068μF ±10% Mylar	C019	DK18103010	0.01μF 50V +100%-0% Cer.
C905	DF16683010	0.068μF ±10% Mylar	C020	DK18103010	0.01μF 50V +100%-0% Cer.
C906	DF16332010	3300pF ±10% Mylar	C021	DK18103010	0.01μF 50V +100%-0% Cer.
C907	DF16332010	3300pF ±10% Mylar	C022	DK18103010	0.01μF 50V +100%-0% Cer.
C908	DF16332010	3300pF ±10% Mylar	R001	RC10680120	68Ω ±10% ½W, Solid
C909	DF16332010	3300pF ±10% Mylar	R002	RC10680120	68Ω ±10% ½W, Solid
C910	DF36101010	100pF ±10% Mylar	R003	RC10082120	8.2Ω ±10% ½W, Solid
C911	DF36101010	100pF ±10% Mylar	R004	RK01040030	100KΩ (B) Variable
C912	DF17333010	0.033μF ±20% Mylar	R005	RM02540080	250KΩ (MN) Variable
C913	DF17333010	0.033μF ±20% Mylar	R006	RM02540090	250KΩ (A) Variable
S901	SP04040012	Push Switch.			

REF. DESIG.	MARANTZ PART NO.	DESCRIPTION	REF. DESIG.	MARANTZ PART NO.	DESCRIPTION
R007	GS10240020	24Ω ±10% 2 W, Wire Wound	J 025	YL01070010	7P Terminal
R008	GS10240020	24Ω ±10% 2 W, Wire Wound	J 026	YL01070010	7P Terminal
R009	GS10022020	2.2Ω ±10% 2 W, Wire Wound	J 027	YL01070010	7P Terminal
R010	GS10022020	2.2Ω ±10% 2 W, Wire Wound	J 028	YL01050040	5P Terminal
R011	RT10331010	330Ω ±10% 1 W, Carbon Film	J 029	YL01030030	3P Terminal
R012	RT10331010	330Ω ±10% 1 W, Carbon Film	J 030	YL01030020	3P Terminal
R013	RC10330120	33Ω ±10% ½W, Solid	J 031	YL01030010	3P Terminal
R014	RC10330120	33Ω ±10% ½W, Solid	J 032	YL01030030	3P Terminal
R015	RJ10222020	2.2KΩ ±10% 2 W, Solid	J 033	YL01030010	3P Terminal
R016	RJ10222020	2.2KΩ ±10% 2 W, Solid	M001	IM1036040	AM-FM Tuning DC Meter
R017	RT10225010	2.2MΩ ±10% 1 W, Carbon Film	M002	IM1036050	FM Tuning DC Meter
R018	RC10182120	1.8KΩ ±10% ½W, Solid	M003	IN10120040	STEREO Ind. Lamp.
R019	RC10271120	270Ω ±10% ½W, Solid	M004	IN10080010	ANT. Tuning Lamp
R021	RT10563140	56KΩ ±10% ¼W, Carbon Film	M005	IN10060030	Meter Illumination Lamp
C016	DK18104020	0.1μF +100% -0% Cer.	M006	IN10060030	Meter Illumination Lamp
C017	DO07473530	0.047μF 600V DC Oil Fillect	M007	IN10060030	Dial Illumination Lamp
C003	DC18102010	0.001μF +100% -0% Feed Through	M008	IN10060030	Dial Illumination Lamp
C004	DC11030022	3pF ±0.5pF Feed Through	M009	IN10060030	Dial Illumination Lamp
C005	DD11050010	5pF ±0.5pF Cer.	M010	IN10060030	Dial Illumination Lamp
C006	DK17103010	0.01μF ±20% Cer.	W001	YC02400060	AC Power Cord
C007	ED33600610	33μF 6.3V Elect.	W002	YW27630050	Wire Material
C008	DF17104520	0.1μF 200V ±20% Mylar	W003	YX27630010	Wire Material
C009	DF17104520	0.1μF 200V ±20% Mylar	F001	FR10400010	4.0A (NW-1) Circuit Breaker
C010	EC47805020	4700μF 50V Elect.	L001	LF11400360	AM Ant Coil
C011	EC47805020	4700μF 50V Elect.	L002	LB30075250	Balun Coil
C012	DG07103500	0.01μF ±20% 250V MP Cap	L003	LC12230010	2μH Ring Core Choke Coil
C013	DG07103500	0.01μF ±20% 250V MP Cap	L004	LC21020010	2μH Ring Core Choke Coil
C014	CA03300010	AM 3 Gang Variable	L005	LC21020010	2μH Ring Core Choke Coil
C015	EA10705010	100μF 50V Elect.	L006	TS60501040	Power Trasf.
C018	EA10700610	100μF 6.3V Elect.	L007	LY20240032	24V DC Relay
S001	SR06060060	Function Rotary Switch	R024	RK02540020	250KΩ B Variable
S002	SP04010070	ANT. Tuning Push Switch	R022	RT10104140	100KΩ ±10% ¼W, Carbon Film
S003	SP04030012	Push Switch	R023	RC10101120	100Ω ±10% ½W, Solid
		S003-1, Muting S003-2, Main, S003-3, Remote.	P980	YD25780112	Speaker Protector PC Board
S004	SP04010062	AC Supply Push Switch	R981	RT10332140	3.3KΩ ±10% ¼W, Carbon Film
S005	SS02020170	FM-Ant. Attenuator Slide Switch	R982	RT10563140	56KΩ ±10% ¼W, Carbon Film
			R983	RT10104140	100KΩ ±10% ¼W, Carbon Film
J001	YT03040030	AM-FM Ant 4P Terminal	R984	RT10274140	270KΩ ±10% ¼W, Carbon Film
J002	YT03040030	Main SP. 4P Terminal	R985	RT10393140	39KΩ ±10% ¼W, Carbon Film
J003	YT03040030	Remote SP. 4P Terminal	R986	RC10271120	270Ω ±10% ½W, Carbon Film
J004	YT02100010	Phono, AUX. Tape -OUT & IN 10P Terminal	R987	RC10562120	5.6KΩ ±10% ½W, Carbon Film
			R988	RC10562120	5.6KΩ ±10% ½W, Carbon Film
J005	YJ01000550	Dubbing OUT Jack	T981	2577118060	Spacer
J006	YJ01000550	Dubbing IN Jack	C981	EA10601620	10μF 16V Elect.
J007	YJ01000650	Headphone Jack	C982	EA22701040	220μF 10V Elect.
J008	YJ04000320	AC Supply Socket	C983	EA10605010	10μF 50V Elect.
J009	YJ04000320	AC Supply Socket	H981	HT308282A0	2SC828 R or S Transistor
J010	YJ02000070	MPX Lamp Socket	H982	HT309842A0	2SC984 C or D Transistor
J011	YJ02000070	ANT Tuning Socket	H983	HT306962A0	2SC696 E or B Transistor
J012	YJ02000480	Meter Illumination Socket	J981	YP10000360	Plug
J013	YJ02000480	Meter Illumination Socket	J982	YP10000360	Plug
J014	YJ02000380	Dial Illumination Socket	J983	YP10000360	Plug
J015	YJ02000390	Dial Illumination Socket	J984	YP10000360	Plug
J016	YJ02000400	Dial Illumination Socket	J987	YP10000360	Plug
J017	YJ02000410	Dial Illumination Socket			
J018	YT01010030	Ground Terminal			
J019	YJ05000140	Power Transistor Socket			
J020	YJ05000140	Power Transistor Socket			
J021	YJ05000140	Power Transistor Socket			
J022	YJ05000140	Power Transistor Socket			
J023	YL01070010	7P Terminal			
J024	YL01070010	7P Terminal			

INTRODUCTION

This service manual was prepared for use by Authorized Warranty Stations and contains service data for the Marantz Model 22 Stereophonic Receiver.

Service information and voltage data included in this manual are intended for use by the knowledgeable and experienced technician only. All instructions should be read carefully. No attempt should be made to proceed without a good understanding of the operation of the Receiver. A brief functional description and associated block diagram, furnished in the Operating Instruction Manual for the Model 22 Receiver, provides functional data about the Receiver as an aid in this understanding.

The parts list furnishes information by which replacement parts may be ordered from the Marantz Company. A description is included for parts which can be usually be obtained through local suppliers.

1. SERVICE NOTES

As can be seen from the circuit diagram the chassis of the Model 22 consists of the following units. Each unit mounted on a printed circuit board is described within the square enclosed by a bold dotted line on the circuit diagram.

1. FM Front End Unit mounted on PC board, P100
2. AM Front End Unit mounted on PC board, P200
3. AM IF Amplifier, FM IF Amplifier, FM MPX Stereo Demodulator, and FM Sub-IF Amplifier All are mounted on PC board, P500
4. Auxiliary Audio Amplifier for FM tuner output, and FM Center tuning Meter Amplifier mounted on PC board, P700
5. Tone Amplifier mounted on PC board, P400
6. PHONO Amplifier mounted on PC board, P300
7. Main Amplifier mounted on PC board, P600
8. High and Low Filter Unit mounted on PC board, P900
9. Regulated Power Supply Unit mounted on PC board, P800
10. Protector Relay Driving Unit mounted on PC board, P980

2. AM TUNER

2.1 Circuit Description

The AM tuner consists of two units, front end and IF amplifier unit mounted on a part of PC board P500.

The front end mounted on a PC board P200 is comprised of an RF amplifier, converter and a diode. The AM signals induced in a ferrite bar antenna are applied to base of the RF amplifier transistor H201 through a capacitor C201 and amplified to the level required for overcoming the converter noise, thus assures good SN performance. The tuned circuits

inserted in out- and input circuit of the RF amplifier gives very high image and spurious rejection performance. Thus amplified and selected signals are applied to the base of converter transistor H202 through a coupling capacitor C206. While the local oscillator voltage is injected to the emitter of H202 through capacitor C207. Both the signals are then mixed at base-emitter junction and converted into 455KHz intermediate frequency. The amplified IF signals obtained from the collector of H202 is applied to the first IF transformer L203.

The diode H203, reverse-biased by resistor R208 and R209, eliminates signal overload distortion without sacrificing any receiving sensitivity.

The IF signal output is led to the IF amplifier consisting of two stages (H510 and H511) through the pin J206 and J504, and amplified to the high level. The amplified IF output is applied to the diode H520 to detect audio signal. Then the detected audio signal is led to the output pin J515 through filtering network. The DC component of the detected IF signals is used as AGC voltage to control emitter current of H510 and RF amplifier transistor H201. A part of IF signal output is also applied to diode H521 through capacitor C562 and rectified to obtain DC current for energizing the signal strength meter M001.

2.2 Suggestion for Trouble Shooting of AM Tuner

Symptom: No AM Reception

First try to tune stations by rotating fly-wheel tuning knob slowly and observe the AM signal strength meter whether it deflects or not. If the signal strength meter gives a deflection at several frequency received, no failure exists in the stages at least preceeding IF transformer L511. Next connect an oscilloscope to the tuner output pin J515 and check audio signal. If the signal strength meter does not deflect, check the local oscillator circuit. Normal oscillator voltage at hot end of the oscillator capacitor is 2 to 3 volts, varying with tuning capacitor position. When measuring oscillator voltage use an RF VTVM, no circuit tester gives correct indication. If the local oscillator voltage is normal, check all voltage distribution in the tuner circuit by using a circuit tester and compare the measured values with those written in the schematic diagram.

3. FM TUNER

3.1 Circuit Description

The FM tuner section consists of three printed circuit boards, FM front end unit, IF amplifier / MPX stereo decoding unit, and DC meter amplifier / FM audio amplifier unit.

FM signals induced by an FM antenna are led to FM antenna coil L101 through an attenuator switch and a BALUN coil. These signals are then applied to FET RF amplifier, the amplified output is applied to FET Mixer H102 through two tuned circuit and converted into 10.7MHz IF signals. H103 is the local oscillator transistor. The AGC voltage, obtained by rectifying a part of first IF output, is applied to the gate of FET H101

through the network R110, R111 and R101. The converted IF signals are led to the input pin J501 of IF amplifier unit consisting of three ICs (H501, H502 and H503) and two ceramic filters having sharp cut off characteristics. The IF signals fully amplified is then applied to the FM discriminator transformer L507 and demodulated into audible signals. The demodulated signals are then applied to the base of composite amplifier transistor H509 to obtain enough output power necessary to drive the stereo decoding circuit packaged in IC H505. The amplified output is applied to the input pin 3 of the IC. Thus L and R channel stereophonic audio signals obtained are led to the FM audio amplifier mounted on a half of PC board P700.

The DC current caused at the point E in the FM discriminator circuit is used as a direct current source for driving the FM center tuning meter M002. First the direct current is led to the base of differential amplifier transistor H701 through R514 and antenna tuning switch S002. The amplified DC output obtained from the emitter of H703 is led to the center tuning meter. R704 is the trimming resistor for null adjustment of the meter.

The stereo decoding IC H505 is also equipped with an audio muting circuit and an automatic stereo-monophonic, switching circuit. Activating signals required for these circuits are obtained from the FM sub-IF amplifier unit consisting of two transistors H506 and H507. The amplifier unit obtains its input signal from the second FM IF amplifier stage through a small coupling capacitor C511 and amplifies it. The amplified output is then applied to the diode H517 and H518 and rectified into direct current. A part of the DC current is supplied to the signal strength meter M001 through resistor R539 and rotary switch S001-3R. The other part is applied to the DC amplifier consisting of H508 and H509, and its output is then fed to the muting control pin of IC H505 through the muting switch S003-1 and resistor R518. R004 is a muting level control variable resistor. Stereo-monophonic, automatic switching signal is also obtained from the rectified circuit and applied to the pin 4 of IC H505 through a resistor R565, R021, Diode H516 and H515.

The model 22 is equipped with a multipath antenna tuning system for the best FM reception. The simple principle of the tuning is given as follows. An FM antenna not correctly positioned toward an FM station induces some kind of distortion in FM signals. Thus deteriorating tonal quality of the programs. To reduce this distortion a suitable antenna direction must be found. For this purpose, the multipath antenna tuning system is employed.

The FM signals converted into 10.7MHz is applied to the sub-IF amplifier, the amplified output is then rectified by the diodes H517 and H518 as stated above. The rectified output is not true direct current but includes many amplitude modulated components caused by unsuitable FM antenna direction. These amplitude modulated components are separated by again detecting the rectified output by the diode H519 and led to the antenna tuning (FM center tuning) meter M002 through antenna tuning switch S002. The greater the deflection of the antenna tuning meter, the greater

the distortion of signal.

3.2 Suggestions for Trouble Shooting of FM Tuner

3.2.1 Symptom: No FM Reception

First turn on the power switch and try to tune FM stations. Rotate the fly wheel tuning knob slowly and observe the FM signal strength meter and FM center tuning meter. If the center tuning meter deflects at several frequency, the tuner circuits preceding the discriminator circuit may have no failure. When the signal strength meter deflects but no deflection is obtained in the center tuning meter, there may be some defects between final FM IF amplifier H404 and the discriminator circuit. When no reading are obtained in both meters, check the local oscillator circuit by using an RF VTVM. Normal local oscillator voltage is about, 1 to 2 volts at hot end of the tank circuit. If the oscillator voltage is normal, check all the voltage distributions and compare them with those shown in the schematic diagram. When both meters deflect but no FM station is obtained check the following points by using a high sensitive oscilloscope; collector of composite amplifier transistor. Multiplex stereo output pin J507 or J508 and FM audio output terminal J711 or J713.

3.2.2 Symptom: No Stereo Separation

First check the MONO (L.R.) switches are in normal "out" position. Connect FM RF signal output modulated by stereo signal to the rear FM antenna terminals and check the stereo beacon lamp is turned on or not. When the lamp is not turned on, connect an oscilloscope to the test point F and observe 38KHz stereo subcarrier is correctly generated or not.

4. FM AND AM TUNER ALIGNMENT

The following alignment for FM and AM tuner requires many precision measurement equipments. No alignment should be performed in the field unless the service man has those equipments and enough knowledge in solid state amplifier components, since all the units are factory aligned and not become misaligned by themselves.

4.1 AM Front End

4.1.1 Local Oscillator and Tracking Alignment

- 1) Set AM signal generator to 600KHz, 400Hz 30% modulation. Tune the receiver to the same frequency and adjust oscillator coil L202 until the dial pointer coincides with the 600KHz marking on the dial.
- 2) Set AM Signal generator to 1400KHz. Tune the receiver to the same frequency and adjust the trimming capacitor mounted on the tuning capacitor.
- 3) Repeat procedure 1 and 2 until no further adjustment is necessary

between the low end and the high end.

- 4) Set the generator to 600KHz. Tune the receiver to the same frequency and adjust antenna coil L001 in the plastic case and RF coil L201 for maximum output.
- 5) Set the generator to 1400KHz. Tune the receiver to the same frequency and adjust each antenna trimming capacitor and RF trimming capacitor mounted on the tuning capacitor for maximum output.
- 6) Repeat procedure 4 and 5 until no further improvement is obtained.

Note: During tracking alignment reduce the signal generator output as necessary to avoid AGC action.

4.2 AM IF Amplifier

For aligning the AM IF-amplifier, a sweep generator with marker generator combined is necessary.

- 1) Connect sweep generator across pin J205 and common ground, connect an oscilloscope to test pin J527.
- 2) Turn each primary and secondary core of IF transformers L203, L510 and L511 for maximum and symmetrical response.

4.3 FM Front End

4.3.1 Local Oscillator Adjustment

- 1) Measuring instruments connection
Connect an FM signal generator to the FM antenna terminals on the back side of the set. Connect a VTVM or an oscilloscope across the speaker system terminals.
- 2) Set FM signal generator to 90MHz, 400Hz 100% modulation. Tune the receiver to the same frequency and adjust oscillator coil L104 until the dial pointer coincides with the 90MHz marking on the dial.
- 3) Set FM signal generator to 106MHz. Tune the receiver to the same frequency and adjust the trimming capacitor C119 until the dial pointer coincides with the 106MHz marking on the dial.
- 4) Repeat procedure 2 and 3 until no further adjustment is necessary between the low end and the high end.

4.3.2 FM Tracking Alignment

- 1) Set FM signal generator to provide about 5uV at 90MHz. Tune the receiver to the same frequency and turn each core of L101, L102 and L103 for maximum output.
- 2) Set FM signal generator to 106MHz. Tune the receiver to the

same frequency and adjust trimming capacitors C104, C110 and C112 for maximum output.

- 3) Repeat procedure until no further improvement is obtained.

4.3.3 FM IF Amplifier

To align this IF amplifier, connect FM signal generator to the FM antenna terminals and set the generator to 98MHz, 400Hz 100% modulation with output level about 5uV. Tune the receiver to this frequency and turn each core of IF transformers, L105 and L519 for maximum output. To align the discriminator transformer L507, increase the FM signal output level to about 2KuV and connect a distortion meter across the tuner output or speaker output terminals.

- 1) First tune the receiver off station until only interstation noise is heard, then turn the secondary core of L507 so that the pointer of center tuning meter indicates its center.
- 2) Tune the receiver to 98MHz FM signals again with center tuning meter in its null position, then turn the primary core of discriminator transformer L507 so that minimum distortion is obtained.

4.3.4 FM Stereo Demodulator

A stereo multiplex and RF FM signal generator is required to make the separation adjustment on this circuit.

Perform the following adjustments in sequence.

- 1) Set FM signal generator to 97MHz, 2KuV output level. Tune the receiver to the same frequency, be sure the pointer of center tuning meter is at the center position, and MONO (L+R) switch is in its normal "out" position.
- 2) Connect oscilloscope probe to pin J526 and turn each core of L514, L512 and L513 for maximum stereo carrier wave on the CRT.
- 3) Turn the core of L514 again so that same stereo separation is obtained in both L and R channels.
- 4) Adjust a trimming resistor R024 for maximum and same stereo separation in both channels.

Note: In early units no trimming resistor is provided.

4.3.5 FM Sub-IF Amplifier Alignment

To align the sub-IF amplifier, tune the receiver to FM signals and turn each core of L508 and L509 so that the FM signal strength meter reads maximum deflection. To read the signal strength meter the antenna tuning switch must be in its normal out position.

5. POWER AMPLIFIER

5.1 Circuit Description

5.1.1 Amplifier

The signal from the tone amplifier is applied to the inverting input (pin 2) of the operational amplifier H601 through the input coupling network R601, C601 and R603. This network provides a high input impedance to the amplifier and prevents any DC from appearing at the op amp input.

The output of the op amp is divided by networks C609/R627 and C611/R631, and is applied to the base of H607 and H611. H607 and H611 provide the voltage amplification necessary to drive the driver (buffer) transistors H613 and H609. H613 and H609 are operated in a complimentary-symmetry configuration with their respective power transistors H001 and H003.

The output of H613 is applied to the base of H001, and the output of H609 is applied to H003. The combined operation of PNP transistors H001 and NPN transistors H003 provide a push-pull output appearing at diodes H005. This output is applied to network R610, L005, and viarelay L007 contact to the LOUDSPEAKER output terminals (J002).

To maintain overall amplifier stability and linearity, degenerative feedback is utilized throughout the amplifier. This feedback is also necessary to reduce distortion to within specified limits. R/C network R611, C603, and R607 condition the feedback signal for application to the non-inverting input (pin 3) of the op amp.

Except for the input, the amplifier uses direct coupling throughout. An offset voltage is applied to pin 3 of the op amp to nullify any undesirable DC output signal. The offset voltage is provided by a voltage divider consisting of R613, R617, and R615 between the plus and minus 14 volt source such that DC OFFSET ADJ. R615 may be adjusted through a plus or minus 1.3 volt range.

5.1.2 Dynamic Bias

Dynamic bias is applied to the bases of driver transistors H613 and H609. H613 and H609, in turn, determine the class of operation for the power amplifier (PA) transistors H001 and H003, thus maintaining a constant class of operation by establishing and maintaining the proper collector-to-emitter current. This dynamic bias circuit is comprised of H967, R961, and temperature sensitive diode H961, H962, H963. The circuit provides a variable base bias for driver transistors H613 and H609 that automatically maintains the proper base voltage (bias condition) with temperature change. Temperature sensitive biasing components of the dynamic bias circuit are thermally coupled through a heatsink to the PA transistors.

5.1.3 Amplifier Protection (figure 5)

Protection for the amplifier is provided by sensing-resistors R641

and R643 operating in conjunction with H603 and H605. When the output power transistors H001 and H003 are over-driven, and the output power exceeds an approximate 55 watts, the current increase through the power output transistors causes an increases current flow through R641 and R643. The resulting voltage drop across R641 and R643 controls the biasing of H603 and H605, resulting in the clipping of any input signal of greater amplitude than is required to cause the power output stage to deliver approximately 55 watts.

5.2 DC Balance and Bias Adjustment of The Main Amplifier

Connect a VTVM across the speaker system output terminal for the channel being tested. Set the voltage range on VTVM to the lowest scale possible, preferably 100 or 300 mV full scale deflection. First turn Bias control resistor R961 and R962 fully clockwise. Adjust DC balance control R615 until no DC voltage is obtained at the speaker terminal strip. Repeat the procedure for the other channel.

Next proceed to the Bias adjustment.

Connect the VTVM across R651 or R653 and adjust bias control resistor R961 until the VTVM reads 10mV. To adjust the other channel bias current connect the VTVM across resistor R654 or R652 and adjust bias control resistor R962 for the same voltage reading.

Note: PC board P960, on which bias control resistors R961 and R962 are located is mounted on backside of the power transistor.

5.3 Suggestions for Trouble Shooting of Power Amplifier

5.3.1 Excessive line consumption (100 watt or more).

- a. Check for shorted rectifiers H006; also check C010 and C011.
- b. Check for shorted transistors H613, H609, H001 and H003, or check H967. Check for open control R961, and bias diode H961--H963. Check L006 for short.

CAUTION: Because the driver and output stages are direct coupled components may fail as a direct result of an initial component failure. If a shorted transistor or Zener diode is found, or control or bias diode, be sure to check the remaining driver and output components for short or open circuit before re-energizing the amplifier.

5.3.2 No Line Consumption or Zero Bias

- a. Check line cord, fuse, transistors H967, H001 and H003, bias diode H961---H963.
- b. Check for open rectifiers H006, or open L006.

5.3.3 High D-C Voltage at Loudspeaker Terminals at all Times.

- a. Check H005 for open or short.

5.3.4 No D-C Balance

- a. Check A1 (op amp) and Zener diodes H615 and H617.
- b. Check R613, R615, and R617.

6. SPEAKER PROTECTOR RELAY CIRCUIT

The speaker protector Relay circuit, mounted on PC board, P980, protects the speaker systems against any loud "POP" sound developed. This circuit is so designed that no sound is heard for the first five seconds after the power switch is turned on by the time constant of capacitor C982 and resistor R984. This circuit also protects the speaker systems against some troubles due to DC off balance between the speaker system terminals by instantly operating the relay and cutting off the speaker systems from the circuit.

7. REGULATED POWER SOURCE ALIGNMENT

The regulated power supply unit mounted on PC board P800 is dual unit. One unit consisting of transistor H801 and H803, supplies its regulated DC current to each unit, FM Front End, AM Front End, AM IF/FM IF and MPX Demodulator and differential amplifier mounted on half of PC board P700. Adjust trimming resistor R811 until the DC voltage between the J804 and ground is 12V. Any short-circuit of the DC output line may damage transistor H801. Be extremely careful not to make a short-circuit. The other unit consisting of transistor H802 and H804, furnishes its regulated output to the Tone amplifier, Phono amplifier and Auxiliary amplifier mounted on half of PC board P700. Adjust trimming resistor R812 for 27V DC output at pin J805. Be careful not to make a short-circuit. Any short circuit may damage transistor H802.

8. CENTER TUNING METER NULL ALIGNMENT

A differential amplifier consisting of four transistors (H701, H702, H703 and H704) is used to drive center tuning meter M002. The input current to the differential amplifier is obtained from the FM discriminator through resistor of R514 and antenna tuning switch S002. The null adjustment of this meter amplifier is done by adjusting trimming resistor R704 with the selector switch placed in the PHONO 1 or 2 position.

9. PHONO and tone amplifiers consist of conventional negative feedback amplifiers and no analytical circuit description may be required.

10. TEST EQUIPMENT FOR SERVICING

Item	Manufacturer and Model No.	Use
AM Signal Generator		Signal Source for AM Alignment
Test Loop		Used with AM Signal Generator
FM Signal Generator	Less than 0.3% distortion	Signal source for FM Alignment
Audio Oscillator	Less than 0.02% residual distortion is required	Sine wave source for modulating AM or FM
Stereo Modulator	Less than 0.3% distortion	Signal Generator, or trouble shooting
Oscilloscope	High Sensitivity	Modulating FM Signal Generator for Separation Alignment and trouble shooting
VTVM	with RF probe	Wave form analysis and trouble shooting
Circuit tester		Trouble shooting
Sweep Generator	For 455KHz and 10.7 MHz IF alignment	AM and FM IF alignment
8-ohm Resistors	±0.5% 50W (no inductive Resistance)	Dummy Load
Line Voltmeter	0---150V AC	Monitors line voltage
Variable Auto transformer	0 to 140V, 10amps	Adjust level of primary power to amplifier

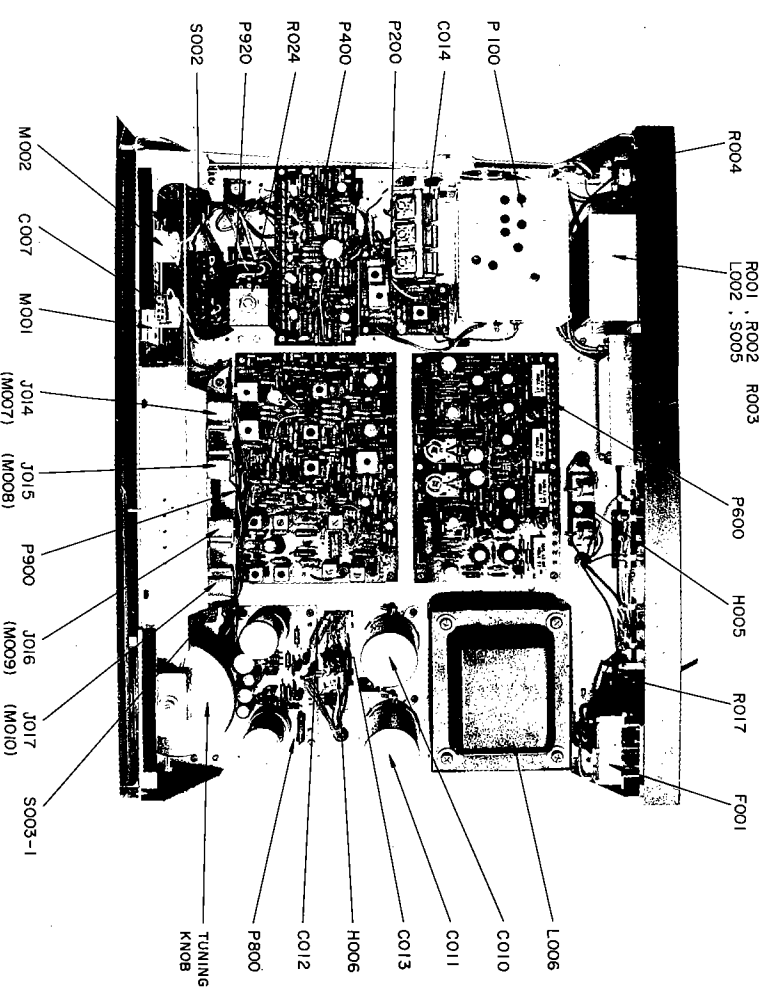

Figure 1 Main Chassis Component Locations Top View

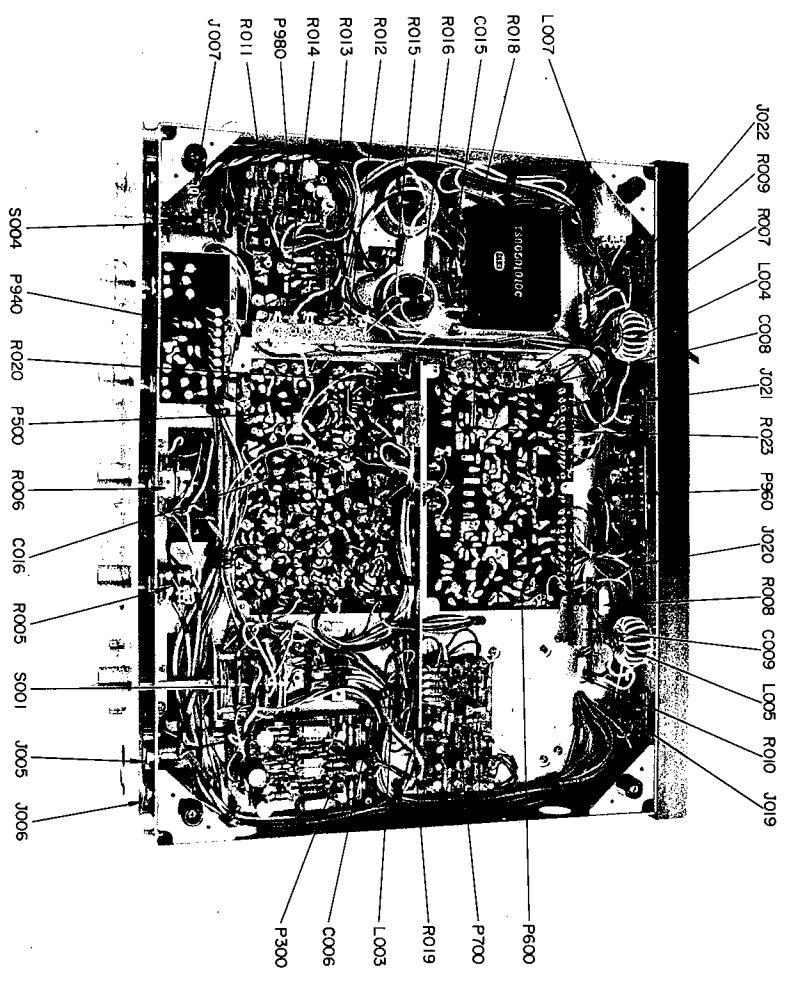

Figure 2 Main Chassis Component Locations Bottom View

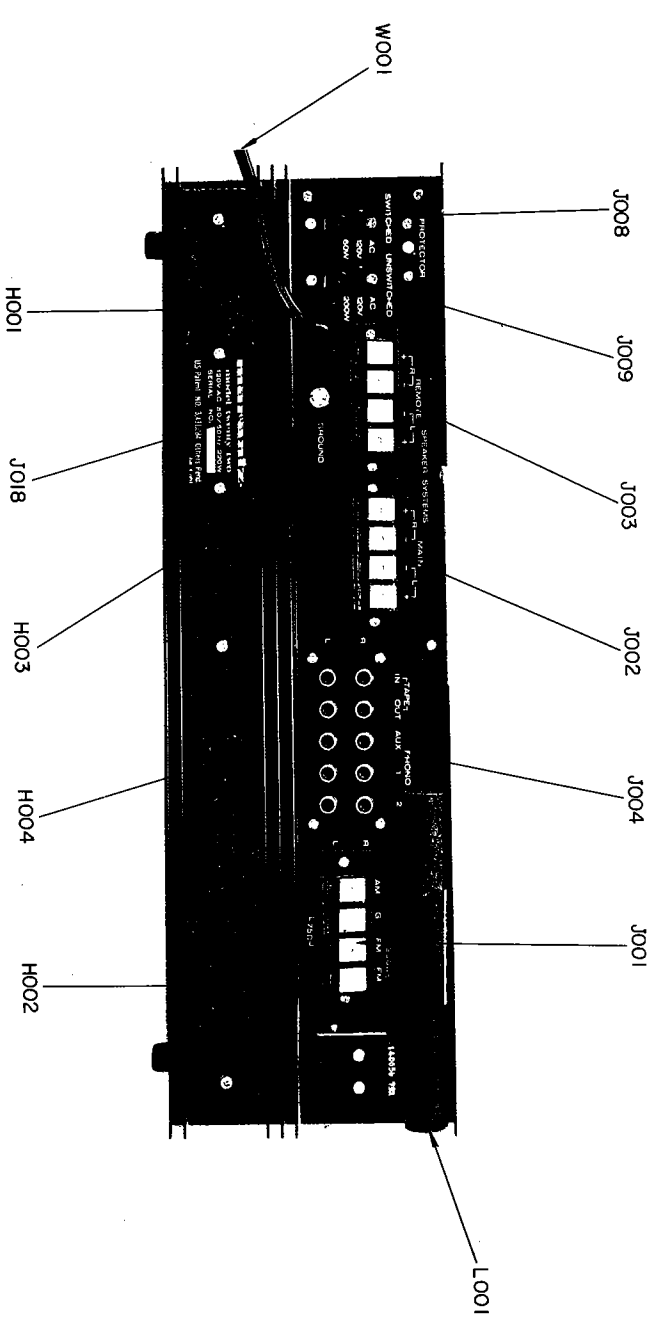

Figure 3 Rear Terminal Component Locations

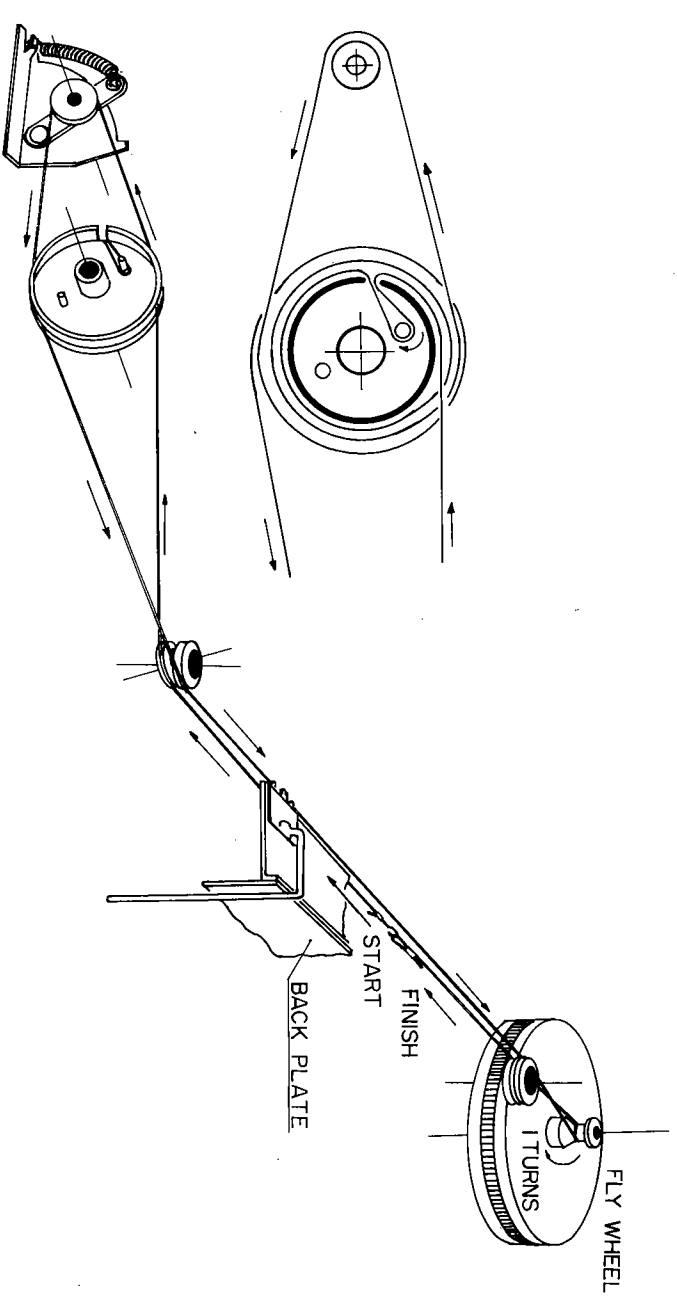

Figure 4 Dial Stringing Diagram

REF. DESIG.	MARANTZ PART NO.	DESCRIPTION	REF. DESIG.	MARANTZ PART NO.	DESCRIPTION
D091	51570306B-0	Push Terminal P. Tapt Screw	D154	53112603E-0	Relay Hexagon Nut
D092	51570306B-0	Push Terminal P. Tapt Screw	D155	54042602N-0	Relay Spring Washer
D093	51570306B-0	Push Terminal P. Tapt Screw			
D094	51570306B-0	Push Terminal P. Tapt Screw	D161	51060306E-9	Heat-Sink + Bracket P.H.M.Screw
D095	51570306B-0	P. Tapt Screw	D162	51060306E-9	Heat-Sink + Bracket P.H.M.Screw
D096	51570306B-0	P. Tapt Screw	D163	51060306E-9	Heat-Sink + Bracket P.H.M.Screw
D097	51570306B-0	P. Tapt Screw	D164	51060306E-9	Heat-Sink + Bracket P.H.M.Screw
D098	51570306B-0	P. Tapt Screw			
D099	51570306B-0	P. Tapt Screw	D173	51060306E-9	Bracket K+ Chassis K P.H.M.Screw
D100	51570306B-0	P. Tapt Screw	D174	51060306E-9	Bracket K+ Chassis K P.H.M.Screw
D101	51570306B-0	P. Tapt Screw	D175	51060306E-9	Bracket K+ Chassis K P.H.M.Screw
D102	51570306B-0	P. Tapt Screw			
D103	51570306B-0	P. Tapt Screw	D176	51060306E-9	Spring P.H.M.Screw
D104	51570306B-0	P. Tapt Screw	D177	51060306E-9	P.C. Board P.H.M.Screw
D105	51570306B-0	P. Tapt Screw	D178	51060306E-9	P.C. Board P.H.M.Screw
D106	51570306B-0	P. Tapt Screw	D181	51060306E-9	(AM Ant. Core) Bracket P.H.M.Screw
D107	51570306B-0	P. Tapt Screw	D182	51060306E-9	(AM Ant. Core) Bracket P.H.M.Screw
D108	51570312B-0	P. Tapt Screw	D183	51060306E-9	(AM Ant. Core) Bracket P.H.M.Screw
D109	51570312B-0	P. Tapt Screw			
D110	51570312B-0	Head Phone Insulator P. Tapt Screw	D184	51060306E-9	Circuit Breaker P.H.M.Screw
D111	51570312B-0	Head Phone Insulator P. Tapt Screw	D185	51060306E-9	Circuit Breaker P.H.M.Screw
D112	51570312B-0	Head Phone Insulator P. Tapt Screw	D186	51060306E-9	Slide Switch P.H.M.Screw
D113	51570312B-0	Head Phone Insulator P. Tapt Screw	D187	51060306E-9	Slide Switch P.H.M.Screw
D114	51570312B-0	Head Phone Insulator P. Tapt Screw	D188	51060306E-9	P.H.M. Screw
D115	51570312B-0	Head Phone Insulator P. Tapt Screw	D189	51060308E-9	AM Ant. + Bracket P.H.M.Screw
D121	51060304H-9	Cover+ Bracket P.H.M.Screw	D190	51060308E-9	AM Ant. + Bracket P.H.M.Screw
D122	51060304H-9	Cover+ Bracket P.H.M.Screw			
D123	51060304H-9	Cover+ Bracket (Guide K) P.H.M.Screw	D191	51060308E-9	10P Terminal P.H.M.Screw
D124	51060304H-9	Cover+ Bracket (Guide K) P.H.M.Screw	D192	51060308E-9	10P Terminal P.H.M.Screw
D125	51060304E-9	Shield+ Shield P.H.M.Screw	D193	51060308E-9	10P Terminal P.H.M.Screw
D126	51060304E-9	Shield+ Shield P.H.M.Screw	D194	51060308E-9	10P Terminal P.H.M.Screw
D129	51060305E-9	Bracket+ Chassis K P.H.M.Screw			
D130	51060305E-9	Bracket+ Chassis K P.H.M.Screw	D201	51140305E-9	Push Switch O.C.H.M.Screw
D131	51060305E-9	Bracket+ Chassis K P.H.M.Screw	D202	51140305E-9	Push Switch O.C.H.M.Screw
D132	51060305E-9	Bracket+ Chassis K P.H.M.Screw	D203	51140305E-9	Push Switch O.C.H.M.Screw
D133	51060305E-9	Meter Bracket P.H.M.Screw	D204	51140305E-9	Push Switch O.C.H.M.Screw
D134	51060305E-9	Meter Bracket P.H.M.Screw	D205	51140305E-9	Push Switch O.C.H.M.Screw
D135	51060305E-9	Meter Bracket P.H.M.Screw	D206	51140305E-9	Push Switch O.C.H.M.Screw
D136	51060305E-9	Bearing K P.H.M.Screw	D207	51140305E-9	Push Switch O.C.H.M.Screw
D137	51060305E-9	Bearing K P.H.M.Screw	D208	51140305E-9	Push Switch O.C.H.M.Screw
D138	51060305E-9	Pulley Bracket K P.H.M.Screw	D209	51140305E-9	AM Variable Cap. O.C.H.M.Screw
D139	51060305E-9	Pulley Bracket K P.H.M.Screw	D210	51140305E-9	AM Variable Cap. O.C.H.M.Screw
D140	51060305E-9	Indicator+ Punched Plate P.H.M.Screw	D211	51140305E-9	AM Variable Cap. O.C.H.M.Screw
D141	51060305E-9	Indicator + Punched Plate P.H.M.Screw	D212	51140308E-9	Push Switch (Ant. Tuning) O.C.H.M. Screw
D142	51060305E-9	Indicator + Punched Plate P.H.M.Screw	D213	51140308E-9	Push Switch (Ant. Tuning) O.C.H.M. Screw
D143	51060305E-9	Indicator + Punched Plate P.H.M.Screw	D214	51570306B-0	Bracket (Relay) P. Tapt Screw
D144	51060305E-9	Punched Plate P.H.M.Screw			
D145	51060305E-9	Shield (10P Terminal) P.H.M.Screw	D215	51570306B-0	Bracket (Relay) P. Tapt Screw
D146	51060305E-9	Shield (10P Terminal) P.H.M.Screw	D216	51570306B-0	Lid P. Tapt Screw
D147	51060305E-9	Shield (10P Terminal) P.H.M.Screw	D217	51570306B-0	Lid P. Tapt Screw
D148	51060305E-9	Shield (10P Terminal) P.H.M.Screw	D218	51570306B-0	Lid P. Tapt Screw
D149	51060305E-9	Shield K+ Bracket K P.H.M.Screw			
D150	51060305E-9	Shield K+ Bracket K P.H.M.Screw			
D151	51060305E-9	Shield K+ Bracket K P.H.M.Screw			
D152	51060305E-9	Shield K+ Bracket K P.H.M.Screw			

REF. DESIG.	MARANTZ PART NO.	DESCRIPTION	REF. DESIG.	MARANTZ PART NO.	DESCRIPTION
D219	51570306B-0	Lid P.Tapt Screw	D288	54110503E-9	Power Transformer Hexagon Nut
D220	51060406E-0	Heat-Sink + Chassis K P.H.M. Screw	D289	54110403E-9	Fly Wheel Hexagon Nut
D221	51060410E-9	Leg P.H.M. Screw	D291	53110303E-9	Indicator Hexagon Nut
D222	51060410E-9	Leg P.H.M. Screw	D292	53110303E-9	Indicator Hexagon Nut
D223	51060410E-9	Leg P.H.M. Screw	D293	53110303E-9	AM Ant. Hexagon Nut
D224	51060410E-9	Leg P.H.M. Screw	D294	53110303E-9	AM Ant. Hexagon Nut
D225	51060425E-9	Coil + Chassis K P.H.M. Screw	D295	53110303E-9	Hexagon Nut
D226	51060425E-9	Coil + Chassis K P.H.M. Screw	D298	53110603E-0	Fly Wheel Hexagon Nut
D227	51060304E-9	P.H.M. Screw	D300	54040302N-0	Lid Spring Washer
D228	51140305E-9	Bearing (Fly Wheel) O.C.H.M. Screw	D301	54040302N-0	Lid Spring Washer
D229	51140305E-9	Bearing (Fly Wheel) O.C.H.M. Screw	D302	54040302N-0	Lid Spring Washer
D231	51100406S-9	Lid + Chassis K B.H.M. Screw	D303	54040302N-0	Lid Spring Washer
D232	51100406S-9	Lid + Chassis K B.H.M. Screw	D304	54040302N-0	Indicator Spring Washer
D233	51100406S-9	Lid + Chassis K B.H.M. Screw	D305	54040302N-0	Indicator Spring Washer
D234	51100406S-9	Lid + Chassis K B.H.M. Screw	D306	54050300R-0	Terminal T.L. Washer OR
D241	51650304D-0	Gear Set Screw H.P.	D307	54050300R-0	Terminal T.L. Washer OR
D242	51650304D-0	Gear Set Screw H.P.	D308	54050300R-0	Terminal T.L. Washer OR
D243	51650304D-0	Gear Set Screw H.P.	D309	54050300R-0	Terminal T.L. Washer OR
D244	51650304D-0	Gear Set Screw H.P.	D310	54050300R-0	Terminal T.L. Washer OR
D247	51640412D-9	Fly Wheel Set Screw C.P.	D311	54050300R-0	Terminal T.L. Washer OR
D249	54040302N-0	Power Transistor Spring Washer	D312	54050300R-0	Terminal T.L. Washer OR
D250	54040302N-0	Power Transistor Spring Washer	D313	54050300R-0	Terminal T.L. Washer OR
D251	54040302N-0	Power Transistor Spring Washer	D314	54050300R-0	Terminal T.L. Washer OR
D252	54040302N-0	Power Transistor Spring Washer	D315	54050300R-0	Terminal T.L. Washer OR
D253	54040302N-0	Power Transistor Spring Washer	D321	54040402N-0	Leg Spring Washer
D254	54040302N-0	Power Transistor Spring Washer	D322	54040402N-0	Leg Spring Washer
D255	54040302N-0	Power Transistor Spring Washer	D323	54040402N-0	Leg Spring Washer
D256	54040302N-0	Power Transistor Spring Washer	D324	54040402N-0	Leg Spring Washer
D258	51570408R-0	P.H. Tapt Screw	D325	54040502N-0	Power Transformer Spring Washer
D259	51570408R-0	P.H. Tapt Screw	D326	54040502N-0	Power Transformer Spring Washer
D261	50060305B-9	Transistor P.H.M. Screw	D327	54040502N-0	Power Transformer Spring Washer
D264	51042608E-0	AC Socket F.H.M. Screw	D328	54040502N-0	Power Transformer Spring Washer
D265	51042608E-0	AC Socket F.H.M. Screw	D329	54040402N-0	Support Spring Washer
D266	51042608E-0	AC Socket F.H.M. Screw	D330	54040402N-0	Support Spring Washer
D267	51042608E-0	AC Socket F.H.M. Screw	D331	54040402N-0	Support Spring Washer
D268	54052600R-0	AC Socket T.L. Washer OR	D332	54040402N-0	Support Spring Washer
D269	54052600R-0	AC Socket T.L. Washer OR	D333	54040402N-0	Fly Wheel Spring Washer
D270	54052600R-0	AC Socket T.L. Washer OR	D334	54040602N-0	Fly Wheel Spring Washer
D271	54052600R-0	AC Socket T.L. Washer OR	D335	54020401E-0	Leg Flat Washer P.
D272	53112603E-0	AC Socket Hexagon Nut	D336	54020401E-0	Leg Flat Washer P.
D273	53112603E-0	AC Socket Hexagon Nut	D337	54020401E-0	Leg Flat Washer P.
D274	53112603E-0	AC Socket Hexagon Nut	D338	54020401E-0	Leg Flat Washer P.
D275	53112603E-0	AC Socket Hexagon Nut	D339	54020501E-0	Power Transformer Flat Washer P.
D281	54050300R-0	Terminal T.L. Washer OR	D340	54020501E-0	Power Transformer Flat Washer P.
D282	54050300R-0	Terminal T.L. Washer OR	D341	54020501E-0	Power Transformer Flat Washer P.
D283	54050300R-0	Terminal T.L. Washer OR	D342	54020501E-0	Power Transformer Flat Washer P.
D285	53110503E-9	Power Transformer Hexagon Nut	D344	54020601E-0	Fly Wheel Flat Washer P.
D286	53110503E-9	Power Transformer Hexagon Nut	D346	54050300R-0	AM Antnna T.L. Washer OR
D287	54110503E-9	Power Transformer Hexagon Nut	D347	54050300R-0	AM Antnna T.L. Washer OR
			D349	54050400R-0	Ground Terminal T.L. Washer OR
			D350	62041760N-0	Ground Terminal Lug

REF. DESIG.	MARANTZ PART NO.	DESCRIPTION
D353	56382040G-0	Eyelet
D354	57271240W-0	Shield K Lug Eyelet
D361	64002400R-0	Pulley RG Ring E
D362	64002400R-0	Pulley RG Ring E
D363	64002400R-0	Pulley RG Ring E
D364	64002400R-0	Pulley RG Ring E
D366	64000400R-0	Drum RG Ring E
D371	51122608E-0	Escutcheon T.H.M. Screw
D372	51122608E-0	Escutcheon T.H.M. Screw
D373	51122608E-0	Escutcheon T.H.M. Screw
D374	51122608E-0	Escutcheon T.H.M. Screw
D377	54020401S-0	Lid Flat Washer S.
D378	54020401S-0	Lid Flat Washer S.
D379	54020401S-0	Lid Flat Washer S.
D380	54020401S-0	Lid Flat Washer S.
D382	54020401E-0	Lid Flat Washer P.
D383	54020401E-0	Lid Flat Washer P.
D384	54020401E-0	Lid Flat Washer P.
D385	54020401E-0	Lid Flat Washer P.
D387	51060312E-9	Power Transistor P.H.M. Screw
D388	51060312E-9	Power Transistor P.H.M. Screw
D389	51060312E-9	Power Transistor P.H.M. Screw
D390	51060312E-9	Power Transistor P.H.M. Screw
D391	51060312E-9	Power Transistor P.H.M. Screw
D392	51060312E-9	Power Transistor P.H.M. Screw
D393	51060312E-9	Power Transistor P.H.M. Screw
D394	51060312E-9	Power Transistor P.H.M. Screw
P100	YD2578001-0	PC Board
R101	RC1010412-0	100K ohm $\pm 10\%$ 1/2W Carbon Film
R102	RC1010512-0	1M ohm $\pm 10\%$ 1/2W Carbon Film
R103	RC1022112-0	220 ohm $\pm 10\%$ 1/2W Carbon Film
R104	RC1027212-0	2.7K ohm $\pm 10\%$ 1/2W Carbon Film
R105	RC1018312-0	18K ohm $\pm 10\%$ 1/2W Carbon Film
R106	RC1010212-0	1K ohm $\pm 10\%$ 1/2W Carbon Film
R107	RC1012212-0	1.2K ohm $\pm 10\%$ 1/2W Carbon Film
R108	RC1047212-0	4.7K ohm $\pm 10\%$ 1/2W Carbon Film
R109	RC1010212-0	1K ohm $\pm 10\%$ 1/2W Carbon Film
R110	RC1022312-0	22K ohm $\pm 10\%$ 1/2W Carbon Film
R111	RC1022312-0	22K ohm $\pm 10\%$ 1/2W Carbon Film
C101	CA4000001-0	FM 4 Gang Variable with Trimmer
C104	CT1100002-0	2.8PF-12.8PF Trimmer
C105	DD1615001-0	15PF $\pm 10\%$ Ceramic
C106	DK1710201-0	0.001uF $\pm 20\%$ Ceramic
C107	CK1710201-0	0.001uF $\pm 20\%$ Ceramic
C108	DD1001001-0	1.0PF ± 0.25 PF Ceramic
C109	DD1615001-0	15PF $\pm 10\%$ Ceramic
C110	CT1100002-0	2.8PF-12.8PF Trimmer
C111	DK1710201-0	0.001uF $\pm 20\%$ Ceramic
C112	CT1100002-0	2.8PF-12.8PF Trimmer

REF. DESIG.	MARANTZ PART NO.	DESCRIPTION
C113	DD1620001-0	20PF $\pm 10\%$ Ceramic
C114	DK1710301-0	0.01uF $\pm 20\%$ Ceramic
C115	DK1710201-0	0.001uF $\pm 20\%$ Ceramic
C116	DD1615003-0	15PF $\pm 10\%$ Ceramic
C117	DD1105002-0	5PF ± 0.5 PF Ceramic
C118	DD1615004-0	15PF $\pm 10\%$ Ceramic
C119	CT1100002-0	2.8PF-12.8PF Trimmer
C120	DK1710201-0	0.001uF $\pm 20\%$ Ceramic
C121	DK1710201-0	0.001uF $\pm 20\%$ Ceramic
C122	DK1710301-0	0.01uF $\pm 20\%$ Ceramic
C123	DK1710301-0	0.01uF $\pm 20\%$ Ceramic
C124	DD1210001-0	10PF ± 1 PF Ceramic
C125	DK1710301-0	0.01uF $\pm 20\%$ Ceramic
C126	DC1103002-2	3PF ± 0.5 PF Feed Through
C127	DC1810201-0	0.001uF +100, -0% Feed Through
C128	DK1710201-0	0.001uF $\pm 20\%$ Ceramic
C129	DD1001001-0	1PF ± 0.25 PF Ceramic
C130	DK1710301-0	0.01uF $\pm 20\%$ Ceramic
L101	LA1004618-0	Antenna Coil
L102	LA1004616-0	RF Coil
L103	LA1004619-0	RF Coil
L104	LO1004603-0	OSC Coil
L105	LI1401619-0	IFT
L106	LC1302001-0	Choke Coil
L107	LC1302001-0	Choke Coil
L108	LC1302001-0	Choke Coil
T101	257810903-0	Shield
T102	257810904-0	Shield
T103	257810905-0	Shield
H101	HF200191A-0	2SK19Y Transistor
H102	HF200191B-0	2SK19GN Transistor
H103	HT308291B-0	2SC829B Transistor
H104	HD1000105-0	IN-60 Diode
H105	HD1000105-0	IN-60 Diode
P200	YD2578002-0	PC Board
R201	RT1056214-0	56K ohm $\pm 10\%$ 1/4W Carbon Film
R202	RT1015414-0	150K ohm $\pm 10\%$ 1/4W Carbon Film
R203	RT1012214-0	1.2K ohm $\pm 10\%$ 1/4W Carbon Film
R204	RT1022114-0	220 ohm $\pm 10\%$ 1/4W Carbon Film
R205	RT1082314-0	82K ohm $\pm 10\%$ 1/4W Carbon Film
R206	RT1033314-0	33K ohm $\pm 10\%$ 1/4W Carbon Film
R207	RT1033214-0	3.3K ohm $\pm 10\%$ 1/4W Carbon Film
R208	RT1012214-0	1.2K ohm $\pm 10\%$ 1/4W Carbon Film
R209	RT1033314-0	33K ohm $\pm 10\%$ 1/4W Carbon Film
R210	RT1012214-0	220 ohm $\pm 10\%$ 1/4W Carbon Film
C201	DK1710301-0	0.01uF $\pm 20\%$ Ceramic
C202	DK1710301-0	0.01uF $\pm 20\%$ Ceramic
C203	DD1615001-0	15PF $\pm 10\%$ Ceramic
C204	DK1840301-0	0.04uF +100, -0% Ceramic
C205	DK1840301-0	0.04uF +100, -0% Ceramic
C206	DK1710301-0	0.01uF $\pm 20\%$ Ceramic
C207	DK1710301-0	0.01uF $\pm 20\%$ Ceramic
C208	DD1620001-0	20PF $\pm 10\%$ Ceramic
C209	DF6539150-0	390PF $\pm 5\%$ Poly
C210	DK1840301-0	0.04uF +100, -0% Ceramic

REF. DESIG.	MARANTZ PART NO.	DESCRIPTION
C211	EA1060162-0	10uF 16V Electroly
L201	LA1001014-0	RF Coil
L202	LO1001035-0	OSC Coil
L203	LI1401001-0	IFT
H201	HT303711B-0	Transistor
H202	HT303711A-0	Transistor
H203	HD1000105-0	Diode
J201	YP1000036-0	Plug
J202	YP1000036-0	Plug
J203	YP1000036-0	Plug
J204	YP1000036-0	Plug
J205	YP1000036-0	Plug
J206	YP1000036-0	Plug
J207	YP1000036-0	Plug
J208	YP1000036-0	Plug
P500	YD2578005-0	PC Board
R502	RT1033114-0	330 ohm $\pm 10\%$ 1/4W Carbon Film
R503	RT1033114-0	330 ohm $\pm 10\%$ 1/4W Carbon Film
R504	RT1027114-0	270 ohm $\pm 10\%$ 1/4W Carbon Film
R505	RT1033114-0	330 ohm $\pm 10\%$ 1/4W Carbon Film
R506	RT1033114-0	330 ohm $\pm 10\%$ 1/4W Carbon Film
R507	RT1027114-0	270 ohm $\pm 10\%$ 1/4W Carbon Film
R508	RT1027214-0	2.7K ohm $\pm 10\%$ 1/4W Carbon Film
R509	RT1010114-0	100 ohm $\pm 10\%$ 1/4W Carbon Film
R510	RT1082114-0	820 ohm $\pm 10\%$ 1/4W Carbon Film
R511	RT1082114-0	820 ohm $\pm 10\%$ 1/4W Carbon Film
R512	RT1033214-0	3.3K ohm $\pm 10\%$ 1/4W Carbon Film
R513	RT1033214-0	3.3K ohm $\pm 10\%$ 1/4W Carbon Film
R514	RT1033414-0	330K ohm $\pm 10\%$ 1/4W Carbon Film
R515	RN1010514-0	1M ohm $\pm 10\%$ 1/4W Carbon Film
R516	RT1039214-0	3.9K ohm $\pm 10\%$ 1/4W Carbon Film
R517	RT1056214-0	5.6K ohm $\pm 10\%$ 1/4W Carbon Film
R518	RT1010414-0	100K ohm $\pm 10\%$ 1/4W Carbon Film
R520	RT1047214-0	4.7K ohm $\pm 10\%$ 1/4W Carbon Film
R521	RT1022214-0	2.2K ohm $\pm 10\%$ 1/4W Carbon Film
R522	RT1068214-0	6.8K ohm $\pm 10\%$ 1/4W Carbon Film
R523	RT1068214-0	6.8K ohm $\pm 10\%$ 1/4W Carbon Film
R524	RT1015314-0	15K ohm $\pm 10\%$ 1/4W Carbon Film
R525	RT1015314-0	15K ohm $\pm 10\%$ 1/4W Carbon Film
R526	RT1056214-0	5.6K ohm $\pm 10\%$ 1/4W Carbon Film
R527	RT1056214-0	5.6K ohm $\pm 10\%$ 1/4W Carbon Film
R528	RT1022314-0	2.2K ohm $\pm 10\%$ 1/4W Carbon Film
R529	RT1033214-0	3.3K ohm $\pm 10\%$ 1/4W Carbon Film
R530	RT1010314-0	10K ohm $\pm 10\%$ 1/4W Carbon Film
R531	RT1082114-0	820 ohm $\pm 10\%$ 1/4W Carbon Film
R532	RT1022114-0	220 ohm $\pm 10\%$ 1/4W Carbon Film
R533	RT1010314-0	10K ohm $\pm 10\%$ 1/4W Carbon Film
R534	RT1015314-0	15K ohm $\pm 10\%$ 1/4W Carbon Film
R535	RT1082114-0	820 ohm $\pm 10\%$ 1/4W Carbon Film
R536	RT1022114-0	220 ohm $\pm 10\%$ 1/4W Carbon Film
R537	RT1022014-0	22 ohm $\pm 10\%$ 1/4W Carbon Film
R538	RT1022014-0	22 ohm $\pm 10\%$ 1/4W Carbon Film
R539	RT1015314-0	15K ohm $\pm 10\%$ 1/4W Carbon Film
R540	RT1010414-0	100K ohm $\pm 10\%$ 1/4W Carbon Film

REF. DESIG.	MARANTZ PART NO.	DESCRIPTION
R541	RT1022414-0	220K ohm $\pm 10\%$ 1/4W Carbon Film
R542	RT1033414-0	330K ohm $\pm 10\%$ 1/4W Carbon Film
R543	RT1010414-0	100K ohm $\pm 10\%$ 1/4W Carbon Film
R544	RT1022214-0	2.2K ohm $\pm 10\%$ 1/4W Carbon Film
R545	RT1015414-0	150K ohm $\pm 10\%$ 1/4W Carbon Film
R546	RT1056214-0	5.6K ohm $\pm 10\%$ 1/4W Carbon Film
R547	RT1010214-0	1K ohm $\pm 10\%$ 1/4W Carbon Film
R548	RT1012214-0	1.2K ohm $\pm 10\%$ 1/4W Carbon Film
R549	RT1027314-0	27K ohm $\pm 10\%$ 1/4W Carbon Film
R550	RT1010314-0	10K ohm $\pm 10\%$ 1/4W Carbon Film
R551	RT1010214-0	1K ohm $\pm 10\%$ 1/4W Carbon Film
R552	RT1022114-0	220 ohm $\pm 10\%$ 1/4W Carbon Film
R553	RT1027314-0	27K ohm $\pm 10\%$ 1/4W Carbon Film
R554	RT1056214-0	5.6K ohm $\pm 10\%$ 1/4W Carbon Film
R555	RT1033214-0	3.3K ohm $\pm 10\%$ 1/4W Carbon Film
R556	RT1033214-0	3.3K ohm $\pm 10\%$ 1/4W Carbon Film
R558	RT1022414-0	220K ohm $\pm 10\%$ 1/4W Carbon Film
R560	RT1022314-0	22K ohm $\pm 10\%$ 1/4W Carbon Film
R561	RT1047414-0	470K ohm $\pm 10\%$ 1/4W Carbon Film
R562	RT1012314-0	12K ohm $\pm 10\%$ 1/4W Carbon Film
R563	RT1015214-0	1.5K ohm $\pm 10\%$ 1/4W Carbon Film
R564	RT1010114-0	100 ohm $\pm 10\%$ 1/4W Carbon Film
R565	RC1022312-0	22K ohm $\pm 10\%$ 1/2W Solid
R566	RT1010414-0	100K ohm $\pm 10\%$ 1/4W Carbon Film
R567	RT1082114-0	820 ohm $\pm 10\%$ 1/4W Carbon Film
R568	RC1010112-0	100 ohm $\pm 10\%$ 1/2W Solid
C501	DK1710301-0	0.01uF $\pm 20\%$ Ceramic Cap.
C502	DK1710301-0	0.01uF $\pm 20\%$ Ceramic Cap.
C503	DK1710301-0	0.01uF $\pm 20\%$ Ceramic Cap.
C504	DK1710301-0	0.01uF $\pm 20\%$ Ceramic Cap.
C505	DK1710301-0	0.01uF $\pm 20\%$ Ceramic Cap.
C506	DK1710301-0	0.01uF $\pm 20\%$ Ceramic Cap.
C507	DK1710301-0	0.01uF $\pm 20\%$ Ceramic Cap.
C508	DK1710301-0	0.01uF $\pm 20\%$ Ceramic Cap.
C510	DK1710301-0	0.01uF $\pm 20\%$ Ceramic Cap.
C511	DD1105001-0	5PF ± 0.5 PF Ceramic Cap.
C512	DK1710301-0	0.01uF $\pm 20\%$ Ceramic Cap.
C513	DK1710301-0	0.01uF $\pm 20\%$ Ceramic Cap.
C514	DK1710301-0	0.01uF $\pm 20\%$ Ceramic Cap.
C515	DK1710301-0	0.01uF $\pm 20\%$ Ceramic Cap.
C516	DK1710301-0	0.01uF $\pm 20\%$ Ceramic Cap.
C517	DK1710301-0	0.01uF $\pm 20\%$ Ceramic Cap.
C518	DD1620101-0	200PF $\pm 10\%$ Ceramic Cap.
C519	EA4750162-0	4.7uF 16V Electroly Cap.
C520	EA1060162-0	10uF 16V Electroly Cap.
C521	DD1620101-0	200PF $\pm 10\%$ Ceramic Cap.
C522	DD1620101-0	200PF $\pm 10\%$ Ceramic Cap.
C523	DD1650101-0	500PF $\pm 10\%$ Ceramic Cap.
C524	ED4750102-0	4.7uF 10V Electroly Cap.
C525	ED1747301-0	0.047uF $\pm 20\%$ Mylar
C526	DF5547201-0	0.0047uF $\pm 5\%$ Mylar
C527	DF5547201-0	0.0047uF $\pm 5\%$ Mylar
C528	DF5412201-0	0.0012uF $\pm 2\%$ Mylar
C529	ED3350163-0	3.3uF 16V Electroly Cap.
C530	DF1633201-0	0.0033uF $\pm 10\%$ Mylar
C531	DF1633201-0	0.0033uF $\pm 10\%$ Mylar

REF. DESIG.	MARANTZ PART NO.	DESCRIPTION	REF. DESIG.	MARANTZ PART NO.	DESCRIPTION
C532	DK1710301-0	0.01uF ±20% Ceramic	L513	LS1001001-0	19 KHz MPX Coil
C533	ED4750102-0	4.7uF 10V Electroly Cap.	L514	LS1001001-0	38 KHz MPX Coil
C534	ED4750102-0	4.7uF 10V Electroly Cap.	L515	LS1001006-0	38 KHz Trap MPX Coil
C535	DF6582101-0	820PF ±5% Poly	L516	LS1001006-0	38 KHz Trap MPX Coil
C536	DF6582101-0	820PF ±5% Poly	L517	LS1001006-0	19 KHz Trap MPX Coil
C537	DF1633201-0	0.0033uF ±10% Mylar	L518	LS1001006-0	19 KHz Trap MPX Coil
C538	DF1633201-0	0.0033uF ±10% Mylar	L519	LI1001616-0	FM IFT
C539	DF1633201-0	0.0033uF ±10% Mylar	F501	FF1107001-0	SFC 10.7 MA Ceramic Cap.
C540	DF1633201-0	0.0033uF ±10% Mylar	F502	DD1107001-0	SFC 10.7 MA Ceramic Cap.
C541	DF1668201-0	0.0068uF ±20% Mylar	H501	HC1000111-0	uA703 IC
C542	DF1668201-0	0.0068uF ±20% Mylar	H502	HC1000114-0	cA3011 IC
C543	DK1710301-0	0.01uF ±20% Ceramic Cap.	H503	HC1000114-0	cA3011 IC
C544	DK1710301-0	0.01uF ±20% Ceramic Cap.	H504	HT306441B-0	2SC644 S Transistor
C545	DK1710301-0	0.01uF ±20% Ceramic Cap.	H505	HC1000117-0 MC1304P IC	466-1008-1A0
C546	DK1710301-0	0.01uF ±20% Ceramic Cap.	H506	HT303801B-0	2SC380 O Transistor
C547	DK1710301-0	0.01uF ±20% Ceramic Cap.	H507	HT303801B-0	2SC380 O Transistor
C548	DD1620101-0	200PF ±10% Ceramic Cap.	H508	HT3037210-0	2SC372 Transistor
C549	DK1710301-0	0.01uF ±20% Ceramic Cap.	H509	HT104951A-0	2SB495 Transistor
C551	EM2240251-0	0.2uF 25V Electroly	H510	HT303711B-0	2SC371 Transistor
C550	DK1710301-0	0.01uF ±20% Ceramic	H511	HT303711A-0	2SC371 Transistor
C552	DK1710301-0	0.01uF ±20% Ceramic Cap.	H513	HD1000105-0	IN-60 Diode
C553	DK1840301-0	0.04uF +100, -0% Ceramic Cap.	H514	HD1000105-0	IN-60 Diode
C554	DK1710301-0	0.01uF ±20% Ceramic Cap.	H515	HD1000101-0	IN34A Diode
C555	DK1710301-0	0.01uF ±20% Ceramic Cap.	H516	HD1000101-0	IN34A Diode
C556	DK1840301-0	0.04uF +100, -0% Ceramic Cap.	H517	HD1000105-0	IN-60 Diode
C557	EA4750161-0	4.7uF 16V Electroly Cap.	H518	HD1000105-0	IN-60 Diode
C558	DK1840301-0	0.04uF +100, -0% Ceramic Cap.	H519	HD1000105-0	IN-60 Diode
C559	DK1840301-0	0.04uF +100, -0% Ceramic Cap.	H520	HD1000105-0	IN-60 Diode
C560	EA4750162-0	4.7uF 16V Electroly Cap.	H521	HD1000105-0	IN-60 Diode
C561	DK1840301-0	0.04uF +100, -0% Ceramic Cap.	J501	YP1000036-0	Plug
C562	DD1530101-0	300PF ±5% Ceramic Cap.	J502	YP1000036-0	Plug
C563	DK1750201-0	0.005uF ±20% Ceramic Cap.	J503	YP1000036-0	Plug
C564	DK1750201-0	0.005uF ±20% Ceramic Cap.	J504	YP1000036-0	Plug
C565	DK1840301-0	0.04uF +100, -0% Ceramic Cap.	J505	YP1000036-0	Plug
C566	DK1710201-0	0.001uF ±20% Ceramic Cap.	J506	YP1000036-0	Plug
C567	DF1747301-0	0.047uF ±20% Mylar	J507	YP1000036-0	Plug
C569	EA4760163-0	47uF 16V Electroly Cap.	J508	YP1000036-0	Plug
C570	ED1060102-0	10uF 10V Electroly Cap.	J509	YP1000036-0	Plug
C571	DK1840301-0	0.04uF +100, -0% Ceramic Cap.	J510	YP1000036-0	Plug
C574	DD1540001-0	40PF ±5% Ceramic Cap.	J511	YP1000036-0	Plug
C575	DD1650101-0	500PF ±10% Ceramic Cap.	J512	YP1000036-0	Plug
C576	EA2270164-0	220uF 16V Electroly Cap.	J513	YP1000036-0	Plug
C577	DK1710301-0	0.01uF ±20% Ceramic Cap.	J514	YP1000036-0	Plug
C578	DK1820301-0	0.02uF +100, -0% Ceramic Cap.	J515	YP1000036-0	Plug
C579	EA2270162-0	220uF 16V Electroly Cap.	J516	YP1000036-0	Plug
L502	LC1223001-0	22uH Coil	J517	YP1000036-0	Plug
L503	LC1223001-0	22uH Coil	J518	YP1000036-0	Plug
L504	LC1223001-0	22uH Coil	J519	YP1000036-0	Plug
L505	LC1223001-0	22uH Coil	J520	YP1000036-0	Plug
L506	LC1223001-0	22uH Coil	J521	YP1000036-0	Plug
L507	LI1401604-3	FM IFT (DET)	J522	YP1000036-0	Plug
L508	LI1015601-0	FM IFT (SUB)	J523	YP1000036-0	Plug
L509	LI1015602-0	FM IFT	J525	YP1000001-0	Plug
L510	LI1401004-0	AM IFT			
L511	LI1401005-0	AM IFT			
L512	LS1001001-0	19 KHz MPX Coil			

REF. DESIG.	MARANTZ PART NO.	DESCRIPTION
J526	YP1000001-0	Plug
J527	YP1000001-0	Plug
J528	YP1000001-0	Plug
W501	YW2578001-0	Wire Materials
P700	YD2578004-0	PC Board
R701	RT1056314-0	56K ohm $\pm 10\%$ 1/4W Carbon Film
R702	RT1056214-0	5.6K ohm $\pm 10\%$ 1/4W Carbon Film
R703	RT1022314-0	22K ohm $\pm 10\%$ 1/4W Carbon Film
R704	RA0502006-0	5K ohm (B) Trimmer
R705	RT1056214-0	5.6K ohm $\pm 10\%$ 1/4W Carbon Film
R706	RT1056314-0	56K ohm $\pm 10\%$ 1/4W Carbon Film
R707	RT1022314-0	22K ohm $\pm 10\%$ 1/4W Carbon Film
R708	RT1010314-0	10K ohm $\pm 10\%$ 1/4W Carbon Film
R709	RT1010314-0	10K ohm $\pm 10\%$ 1/4W Carbon Film
R710	RT1022314-0	22K ohm $\pm 10\%$ 1/4W Carbon Film
R711	RN1047414-0	470K ohm $\pm 10\%$ 1/4W Carbon Film
R712	RN1047414-0	470K ohm $\pm 10\%$ 1/4 W Carbon Film
R713	RN1015414-0	150K ohm $\pm 10\%$ 1/4W Carbon Film
R714	RN1015414-0	150K ohm $\pm 10\%$ 1/4W Carbon Film
R715	RN1022314-0	22K ohm $\pm 10\%$ 1/4W Carbon Film
R716	RN1022314-0	22K ohm $\pm 10\%$ 1/4W Carbon Film
R717	RT1056214-0	5.6K ohm $\pm 10\%$ 1/4W Carbon Film
R718	RT1056214-0	5.6K ohm $\pm 10\%$ 1/4W Carbon Film
R719	RT1010214-0	5.6K ohm $\pm 10\%$ 1/4W Carbon Film
R720	RT1010214-0	5.6K ohm $\pm 10\%$ 1/4W Carbon Film
R721	RT1015314-0	15K ohm $\pm 10\%$ 1/4W Carbon Film
R722	RT1015314-0	15K ohm $\pm 10\%$ 1/4W Carbon Film
R723	RT1012214-0	1.2K ohm $\pm 10\%$ 1/4W Carbon Film
R724	RT1068114-0	680 ohm $\pm 10\%$ 1/4W Carbon Film
R725	RT1022414-0	220K ohm $\pm 10\%$ 1/4W Carbon Film
R726	RT1022414-0	220K ohm $\pm 10\%$ 1/4W Carbon Film
C701	EN2240251-0	0.22uF $\pm 20\%$ 25V Electroly Cap.
C702	EV2240251-0	0.22uF $\pm 20\%$ 25V Electroly Cap.
C703	EA1060351-0	10uF 35V Electroly Cap.
C704	EA1060351-0	10uF 35V Electroly Cap.
C705	EA1070252-0	100uF 25V Electroly Cap.
C706	EM4740251-0	0.47uF $\pm 20\%$ 25V Electroly Cap.
C707	EM4740251-0	0.47uF $\pm 20\%$ 25V Electroly Cap.
H701	HT3037210-0	2SC372 Transistor
H702	HT3037210-0	2SC372 Transistor
H703	HT104951A-0	2SA495 R Transistor
H704	HT104951A-0	2SA495 R Transistor
H705	HT307321B-0	2SC732 BL Transistor
H706	HT307321B-0	2SC732 BL Transistor
H707	HT104941C-0	2SA494 Y Transistor
H708	HT104941C-0	2SA494 Y Transistor
H709	HD3001009-0	IS336 Diode
J701	YP1000036-0	Plug
J702	YP1000036-0	Plug
J703	YP1000036-0	Plug
J704	YP1000036-0	Plug
J705	YP1000036-0	Plug
J706	YP1000036-0	Plug

REF. DESIG.	MARANTZ PART NO.	DESCRIPTION
J707	YP1000036-0	Plug
J708	YP1000036-0	Plug
J709	YP1000036-0	Plug
J710	YP1000036-0	Plug
J711	YP1000036-0	Plug
J712	YP1000036-0	Plug
J713	YP1000036-0	Plug
P300	YD2577003-0	Phono Amp PC Board
R301	RN1047314-0	47K ohm $\pm 10\%$ 1/4W Carbon Film
R302	RN1047314-0	47K ohm $\pm 10\%$ 1/4W Carbon Film
R303	RT1039114-0	390 ohm $\pm 10\%$ 1/4W Carbon Film
R304	RT1039114-0	390 ohm $\pm 10\%$ 1/4W Carbon Film
R305	RN1033414-0	330K ohm $\pm 10\%$ 1/4W Carbon Film
R306	RN1033414-0	330K ohm $\pm 10\%$ 1/4W Carbon Film
R307	GT0533112-0	330 ohm $\pm 5\%$ 1/2W Carbon Film
R308	GT0533112-0	330 ohm $\pm 5\%$ 1/2W Carbon Film
R309	GT0533412-0	330K ohm $\pm 5\%$ 1/2W Carbon Film
R310	GT0533412-0	330K ohm $\pm 5\%$ 1/2W Carbon Film
R311	GT0527312-0	27K ohm $\pm 5\%$ 1/2W Carbon Film
R312	GT0527312-0	27K ohm $\pm 5\%$ 1/2W Carbon Film
R313	RN1010414-0	100K ohm $\pm 10\%$ 1/4W Carbon Film
R314	RN1010414-0	100K ohm $\pm 10\%$ 1/4W Carbon Film
R315	RT1010314-0	10K ohm $\pm 10\%$ 1/4W Carbon Film
R316	RT1015314-0	15K ohm $\pm 10\%$ 1/4W Carbon Film
R317	RT1015314-0	15K ohm $\pm 10\%$ 1/4W Carbon Film
R318	RT1015214-0	1.5K ohm $\pm 10\%$ 1/4W Carbon Film
R319	RT1015214-0	1.5K ohm $\pm 10\%$ 1/4W Carbon Film
R320	RT1047114-0	470 ohm $\pm 10\%$ 1/4W Carbon Film
R321	RT1047114-0	470 ohm $\pm 10\%$ 1/4W Carbon Film
R322	RT1047014-0	47 ohm $\pm 10\%$ 1/4W Carbon Film
R323	RN1033414-0	330K ohm $\pm 10\%$ 1/4W Carbon Film
R324	RN1033414-0	330K ohm $\pm 10\%$ 1/4W Carbon Film
C301	EV2250251-0	2.2uF 25V +40, -20% Electroly Cap.
C302	EV2250251-0	2.2uF 25V +40, -20% Electroly Cap.
C303	EA2260351-0	22uF 35V +100, -0% Electroly Cap.
C304	DF6410301-0	0.01uF 50V $\pm 2\%$ Poly
C305	DF6410301-0	0.01uF 50V $\pm 2\%$ Poly
C308	EA1070061-0	100uF 6.3V +100, -0% Electroly Cap.
C309	EA1070061-0	100uF 6.3V +100, -0% Electroly Cap.
C310	EV1050251-0	1uF 25V +40 -20% Electroly Cap.
C311	EV1050251-0	1uF 25V +40 -20% Electroly Cap.
C312	EA1070351-0	100uF 35V Electroly Cap.
C316	DF6427201-0	0.0027uF 50V $\pm 2\%$ Poly
C317	DF6427201-0	0.0027uF 50V $\pm 2\%$ Poly
H301	HT306441C-0	2SC644(T) Transistor
H302	HT306441C-0	2SC644(T) Transistor
H303	HF200301C-0	2SK30(Y) Transistor
H304	HF200301C-0	2SK30(Y) Transistor
J301	YP1000036-0	Plug
J302	YP1000036-0	Plug
J303	YP1000036-0	Plug
J304	YP1000036-0	Plug

REF. MARANTZ	REF. MARANTZ
DESIG. PART NO.	DESIG. PART NO.
DESCRIPTION	DESCRIPTION
J305 YP1000036-0 Plug	H403 HT104941C-0 2SA494 (Y) Transistor
J306 YP1000036-0 Plug	H404 HT104941C-0 2SA494 (Y) Transistor
J307 YP1000036-0 Plug	H405 HT307321B-0 2SC732 (BL) Transistor
	H406 HT307321B-0 2SC732 (BL) Transistor
P400 YD2577004-0 Tone Amp PC Board	H407 HT104941B-0 2SA494 (Y) Transistor
	H408 HT104941C-0 2SA494 (Y) Transistor
R401 RT1039114-0 390 ohm $\pm 10\%$ 1/4W Carbon Film	J401-J420 YP1000036-0 Plug
R402 RT1039114-0 390 ohm $\pm 10\%$ 1/4W Carbon Film	W401 YW2577004-0 Wire Materials
R403 RN1047314-0 47K ohm $\pm 10\%$ 1/4W Carbon Film	P600 YD2578006-0 Main Amp PC Board
R404 RN1047314-0 47K ohm $\pm 10\%$ 1/4W Carbon Film	R601 RN1047414-0 470K ohm $\pm 10\%$ 1/4W Carbon Film
R405 RN1056314-0 56K ohm $\pm 10\%$ 1/4W Carbon Film	R602 RN1047414-0 470K ohm $\pm 10\%$ 1/4W Carbon Film
R406 RN1056314-0 56K ohm $\pm 10\%$ 1/4W Carbon Film	R603 GT0510212-0 1K ohm $\pm 5\%$ 1/2W Carbon Film
R407 RT1068214-0 6.8K ohm $\pm 10\%$ 1/4W Carbon Film	R604 GT0510212-0 1K ohm $\pm 5\%$ 1/2W Carbon Film
R408 RT1068214-0 6.8K ohm $\pm 10\%$ 1/4W Carbon Film	R605 RN1047314-0 47K ohm $\pm 10\%$ 1/4W Carbon Film
R409 RN1022314-0 22K ohm $\pm 10\%$ 1/4W Carbon Film	R606 RN1047314-0 47K ohm $\pm 10\%$ 1/4W Carbon Film
R410 RN1022314-0 22K ohm $\pm 10\%$ 1/4W Carbon Film	R607 GT0282112-0 820 ohm $\pm 2\%$ 1/2W Carbon Film
	R608 GT0282112-0 820 ohm $\pm 2\%$ 1/2W Carbon Film
R411 RT1027214-0 2.7K ohm $\pm 10\%$ 1/4W Carbon Film	R609 GT0510412-0 100K ohm $\pm 5\%$ 1/2W Carbon Film
R412 RT1027214-0 2.7K ohm $\pm 10\%$ 1/4W Carbon Film	R610 GT0510412-0 100K ohm $\pm 5\%$ 1/2W Carbon Film
R413 RT1010214-0 1K ohm $\pm 10\%$ 1/4W Carbon Film	
R414 RT1010214-0 1K ohm $\pm 10\%$ 1/4W Carbon Film	R611 GT0515312-0 15K ohm $\pm 5\%$ 1/2W Carbon Film
R415 RN1015314-0 15K ohm $\pm 10\%$ 1/4W Carbon Film	R612 GT0515312-0 15K ohm $\pm 5\%$ 1/2W Carbon Film
R416 RN1015314-0 15K ohm $\pm 10\%$ 1/4W Carbon Film	R613 GT0510312-0 10K ohm $\pm 5\%$ 1/2W Carbon Film
R417 RT1010114-0 100 ohm $\pm 10\%$ 1/4W Carbon Film	R614 GT0510312-0 10K ohm $\pm 5\%$ 1/2W Carbon Film
R418 RN1056314-0 56K ohm $\pm 10\%$ 1/4W Carbon Film	R615 RA0202003-0 2K ohm (B) Semi Fix
R419 RN1056314-0 56K ohm $\pm 10\%$ 1/4W Carbon Film	R616 RA0202003-0 2K ohm (B) Semi Fix
R420 GT0522312-0 22K ohm $\pm 5\%$ 1/2W Carbon Film	R617 GT0510312-0 10K ohm $\pm 5\%$ 1/2W Carbon Film
	R618 GT0510312-0 10K ohm $\pm 5\%$ 1/2W Carbon Film
R421 GT0522312-0 22K ohm $\pm 5\%$ 1/2W Carbon Film	R619 RC1018212-0 1.8K ohm $\pm 10\%$ 1/2W Solid
R422 RN1022514-0 2.2M ohm $\pm 10\%$ 1/4W Carbon Film	R620 RC1018212-0 1.8K ohm $\pm 10\%$ 1/2W Solid
R423 RN1022514-0 2.2M ohm $\pm 10\%$ 1/4W Carbon Film	
R424 RN1068314-0 68K ohm $\pm 10\%$ 1/4W Carbon Film	R621 RT1082114-0 820 ohm $\pm 10\%$ 1/4W Carbon Film
R425 RN1068314-0 68K ohm $\pm 10\%$ 1/4W Carbon Film	R622 RT1082114-0 820 ohm $\pm 10\%$ 1/4W Carbon Film
R426 RT1010314-0 10K ohm $\pm 10\%$ 1/4W Carbon Film	R623 RC1018212-0 1.8K ohm $\pm 10\%$ 1/4W Solid
R427 RT1010314-0 10K ohm $\pm 10\%$ 1/4W Carbon Film	R624 RC1018212-0 1.8K ohm $\pm 10\%$ 1/4W Solid
R428 RT1010314-0 10K ohm $\pm 10\%$ 1/4W Carbon Film	R625 GT0562112-0 620 ohm $\pm 5\%$ 1/2W Carbon Film
R429 RT1010314-0 10K ohm $\pm 10\%$ 1/4W Carbon Film	R626 GT0562112-0 620 ohm $\pm 5\%$ 1/2W Carbon Film
R430 RT1022114-0 220 ohm $\pm 10\%$ 1/4W Carbon Film	R627 GT0518312-0 18K ohm $\pm 5\%$ 1/2W Carbon Film
	R628 GT0518312-0 18K ohm $\pm 5\%$ 1/2W Carbon Film
R431 RT1022114-0 220 ohm $\pm 10\%$ 1/4W Carbon Film	R629 GT0518312-0 18K ohm $\pm 5\%$ 1/2W Carbon Film
R432 RN1010414-0 100K ohm $\pm 10\%$ 1/4W Carbon Film	R630 GT0518312-0 18K ohm $\pm 5\%$ 1/2W Carbon Film
R433 RN1010414-0 100K ohm $\pm 10\%$ 1/4W Carbon Film	
C401 EV2240251-0 0.22uF 25V $\pm 20\%$ Electroly Cap.	R631 GT0518312-0 18K ohm $\pm 5\%$ 1/2W Carbon Film
C402 EV2240251-0 0.22uF 25V $\pm 20\%$ Electroly Cap.	R632 GT0518312-0 18K ohm $\pm 5\%$ 1/2W Carbon Film
C403 EA2250251-0 2.2uF 25V +40, -20% Electroly Cap.	R633 GT0547112-0 470 ohm $\pm 5\%$ 1/2W Carbon Film
C404 EA2250251-0 2.2uF 25V +40, -20% Electroly Cap.	R634 GT0547112-0 470 ohm $\pm 5\%$ 1/2W Carbon Film
C405 EA2260351-0 22uF 25V Electroly Cap.	R635 RC1010112-0 100 ohm $\pm 10\%$ 1/2W Solid
C406 EA2260351-0 22uF 35V Electroly Cap.	R636 RC1010112-0 100 ohm $\pm 10\%$ 1/2W Solid
C407 EV2250251-0 2.2uF 25V +40, -20% Electroly Cap.	R637 RC1010112-0 100 ohm $\pm 10\%$ 1/2W Solid
C408 EV2250251-0 2.2uF 25V +40, -20% Electroly Cap.	R638 RC1010112-0 100 ohm $\pm 10\%$ 1/2W Solid
C409 EA1070351-0 100uF 35V	R639 GT0533112-0 330 ohm $\pm 10\%$ 1/2W Carbon Film
C410 EV2250251-0 2.2uF 25V +40, -20% Electroly Cap.	R640 GT0533112-0 330 ohm $\pm 10\%$ 1/2W Carbon Film
C411 EV2250251-0 2.2uF 25V +40, -20% Electroly Cap.	R641 GT0522112-0 220 ohm $\pm 10\%$ 1/2W Carbon Film
C412 DF6545101-0 450PF $\pm 5\%$ Poly	R642 GT0522112-0 220 ohm $\pm 10\%$ 1/2W Carbon Film
C413 DF6545101-0 450PF $\pm 5\%$ Poly	R643 GT0515112-0 150 ohm $\pm 10\%$ 1/2W Carbon Film
C414 EV1050251-0 1uF 25V +40, -20% Electroly Cap.	R644 GT0515112-0 150 ohm $\pm 10\%$ 1/2W Carbon Film
C415 EV1050251-0 1uF 25V +40, -20% Electroly Cap.	R645 GT0533112-0 330 ohm $\pm 10\%$ 1/2W Carbon Film
H401 HT307321B-0 2SC732 (BL) Transistor	
H402 HT307321B-0 2SC732 (BL) Transistor	

REF. DESIG.	MARANTZ PART NO.	DESCRIPTION	REF. DESIG.	MARANTZ PART NO.	DESCRIPTION
R646	GT0533112-0	330 ohm $\pm 10\%$ 1/2W Carbon Film	T601-T608	257726702-0	Heat Sink
R647	RC1010112-0	100 ohm $\pm 10\%$ 1/2W Solid	T609-T616	257711806-0	Spacer
R648	RC1010112-0	100 ohm $\pm 10\%$ 1/2W Solid	P800	YD2578008-0	Power Supply PC Board
R649	RC1010112-0	100 ohm $\pm 10\%$ 1/2W Solid	R801	HW1047002-0	47 ohm $\pm 10\%$ 2W Wire Wound
R650	RC1010112-0	100 ohm $\pm 10\%$ 1/2W Solid	R802	RC1047012-0	47 ohm $\pm 10\%$ 2W Solid
R651	GW1020205-0	0.2 ohm $\pm 10\%$ 5W Wire Wound	R803	RC1027212-0	2.7K ohm $\pm 10\%$ 1/2W Solid
R652	GW1020205-0	0.2 ohm $\pm 10\%$ 5W Wire Wound	R804	RC1010212-0	1K ohm $\pm 10\%$ 1/2W Solid
R653	GW1020205-0	0.2 ohm $\pm 10\%$ 5W Wire Wound	R805	RC1047212-0	4.7K ohm $\pm 10\%$ 1/2W Solid
R654	GW1020205-0	0.2 ohm $\pm 10\%$ 5W Wire Wound	R806	RC1047212-0	4.7K ohm $\pm 10\%$ 1/2W Solid
C601	DF2710550-0	1uF $\pm 20\%$ 100V Mylar	R807	RC1010212-0	1K ohm $\pm 10\%$ 1/2W Solid
C602	DF2710550-0	1uF $\pm 20\%$ 100V Mylar	R808	RC1033212-0	3.3K ohm $\pm 10\%$ 1/2W Solid
C603	DF2610151-0	100PF $\pm 10\%$ 500V Mica	R809	RC1022212-0	2.2K ohm $\pm 10\%$ 1/2W Solid
C604	DF3610151-0	100PF $\pm 10\%$ 500V Mica	R810	RC1015312-0	15K ohm $\pm 10\%$ 1/2W Solid
C605	EA1070163-0	100uF 16V Electroly Cap.	R811	RA0302001-0	3K ohm (B) Trimmer
C606	EA1070163-0	100uF 16V Electroly Cap.	R812	RA0103001-0	10K ohm (B) Trimmer
C607	EA1070163-0	100uF 16V Electroly Cap.	R813	RC1027212-0	2.7K ohm $\pm 10\%$ 1/2W Solid
C608	EA1070163-0	100uF 16V Electroly Cap.	C801	EB1080501-0	1000uF 50V Electroly Cap.
C609	DF1710451-0	0.1uF $\pm 20\%$ 100V Mylar	C802	EB1080501-0	1000uF 50V Electroly Cap.
C610	DF1710451-0	0.1uF $\pm 20\%$ 100V Mylar	C803	EA4760352-0	47uF 35V Electroly Cap.
C611	DF1710451-0	0.1uF $\pm 20\%$ 100V Mylar	C804	EA4770351-0	470uF 35V Electroly Cap.
C612	DF1710451-0	0.1uF $\pm 20\%$ 100V Mylar	C805	EA1070163-0	100uF 16V Electroly Cap.
C615	DF1722402-0	0.22uF $\pm 20\%$ Mylar	C806	EA4760352-0	47uF 35V Electroly Cap.
C616	DF1722402-0	0.22uF $\pm 20\%$ Mylar	H801	HT304961C-0	2SC496 (Y) Transistor
C620	DK1810351-0	0.01uF 500V +100, -0% Ceramic Cap.	H802	HT304961C-0	2SC496 (Y) Transistor
C621	DK1810351-0	0.01uF 500V +100, -0% Ceramic Cap.	H803	HT307341C-0	2SC734 (Y) Transistor
H601	HC1000217-0	MC1741 (Motorola) IC	H804	HT307341C-0	2SC734 (Y) Transistor
H602	HC1000217-0	MC1741 (Motorola) IC <i>SC51756</i>	H805	HD3000309-0	IS332 Diode
H603	HT105621B-0	2SA562 (O) Transistor	H806	HD3000309-0	IS332 Diode
H604	HT105621B-0	2SA562 (O) Transistor	J801-J805	YP1000036-0	Plug
H605	HT303711B-0	2SC371 (O) Transistor	P900	YD2578009-0	For Switch PC Board
H606	HT303711B-0	2SC371 (O) Transistor	R901	GT0547212-0	4.7K ohm $\pm 5\%$ 1/2W Carbon Film
H607	HT104971A-0	2SA497 (R) Transistor	R902	GT0547212-0	4.7K ohm $\pm 5\%$ 1/2W Carbon Film
H608	HT104971A-0	2SA497 (R) Transistor	R903	GT0547212-0	4.7K ohm $\pm 5\%$ 1/2W Carbon Film
H609	HT104971A-0	2SA497 (R) Transistor	R904	GT0547212-0	4.7K ohm $\pm 5\%$ 1/2W Carbon Film
H610	HT104971A-0	2SA497 (R) Transistor	R905	GT0556312-0	56K ohm $\pm 5\%$ 1/2W Carbon Film
H611	HT304971A-0	2SC497 (R) Transistor	R906	GT0556312-0	56K ohm $\pm 5\%$ 1/2W Carbon Film
H612	HT304971A-0	2SC497 (R) Transistor	R907	RN1010514-0	1M ohm $\pm 10\%$ 1/4W Carbon Film
H613	HT304971A-0	2SC497 (R) Transistor	R908	RN1010514-0	1M ohm $\pm 10\%$ 1/4W Carbon Film
H614	HT304971A-0	2SC497 (R) Transistor	R909	RN1022514-0	2.2M ohm $\pm 10\%$ 1/4W Carbon Film
H615	HD3001109-0	IS198 Diode	R910	RN1022514-0	2.2M ohm $\pm 10\%$ 1/4W Carbon Film
H616	HD3001109-0	IS198 Diode	R911	RT1010314-0	10K ohm $\pm 10\%$ 1/4W Carbon Film
H617	HD3001109-0	IS198 Diode	R912	RT1010314-0	10K ohm $\pm 10\%$ 1/4W Carbon Film
H618	HD3001109-0	IS198 Diode	R913	RT1015414-0	150K ohm $\pm 10\%$ 1/4W Carbon Film
H619	HV0000105-0	M8513 (R) Varistor	R914	RT1015414-0	150K ohm $\pm 10\%$ 1/4W Carbon Film
H620	HV0000105-0	M8513 (R) Varistor	C901	DF5547201-0	4700PF $\pm 5\%$ Poly
H621	HV0000105-0	M8513 (R) Varistor	C902	DF1668301-0	0.068uF $\pm 10\%$ Mylar
H622	HV0000105-0	M8513 (R) Varistor	C903	DF1668301-0	0.068uF $\pm 10\%$ Mylar
J601-J603	YP1000036-0	Plug	C904	DF1668301-0	0.068uF $\pm 10\%$ Mylar
J605-J622	YP1000036-0	Plug	C905	DF1668301-0	0.068uF $\pm 10\%$ Mylar
J624-J627	YP1000036-0	Plug			

REF. DESIG.	MARANTZ PART NO.	DESCRIPTION	REF. DESIG.	MARANTZ PART NO.	DESCRIPTION
C906	DF1633201-0	3300PF ±10% Mylar	H004	HT9000410-0	SJ2000 (NPN) Transistor
C907	DF1633201-0	3300PF ±10% Mylar	H005	HD2000405-0	M9235F For Protector Diode
C908	DF1633201-0	3300PF ±10% Mylar	R001	RC1068012-0	68 ohm ±10% 1/2W Solid
C909	DF1633201-0	3300PF ±10% Mylar	R002	RC1068012-0	68 ohm ±10% 1/2W Solid
C910	DF3610101-0	100PF ±10% Mica	R003	RC1008212-0	8.2 ohm ±10% 1/2W Solid
C911	DF3610101-0	100PF ±10% Mica	R004	RK0104003-0	100K ohm (B) Variable
C912	DF1733301-0	0.033uF ±20% Mylar	R005	RM0254008-0	250K ohm (MN) Variable
C913	DF1733301-0	0.033uF ±20% Mylar	R006	RM0254008-0	250K ohm (A) Variable
S901	SP0404001-2	For Hi Blend Low Filter Hi Filter Loudness. Push Switch	R007	GS1024002-0	24 ohm ±10% 2W Wire Wound
P920	YD2578003-0	For Switch PC Board	R008	GS1024002-0	24 ohm ±10% 2W Wire Wound
R920	RT1010214-0	1K ohm ±10% 1/4W Carbon Film	R009	GS1002202-0	2.2 ohm ±10% 2W Wire Wound
R922-R924	RT1010214-0	1K ohm ±10% 1/4W Carbon Film	R010	GS1002202-0	2.2 ohm ±10% 2W Wire Wound
S921	SP0403001-2	S920-1 S920-2 S920-3 Tape Moni. "L" Mono "R" Push Switch	R011	RT1033101-0	330 ohm ±10% 1W Carbon Film
J921-J923	YP1000036-0	Plug	R012	RT1033101-0	330 ohm ±10% 1W Carbon Film
W921	YW2578002-0	Wire Materials	R013	RC1033012-0	33 ohm ±10% 1/2W Carbon Film
P940	YD2578010-0	Tone-Control PC Board	R014	RC1033012-0	33 ohm ±10% 1/2W Carbon Film
R941	RD0104001-0	100K ohm B Treble Variable	R015	RJ1022202-0	2.2K ohm ±10% 2W Carbon Film
R942	RD0104001-0	100K ohm B Bass Variable	R016	RJ1022202-0	2.2K ohm ±10% 2W Carbon Film
R943	GT0516312-0	16K ohm ±5% 1/2W Carbon Film	R017	RJ1022501-0	2.2M ohm ±10% 1W Carbon Film
R944	GT0516312-0	16K ohm ±5% 1/2W Carbon Film	R018	RC1018212-0	1.8K ohm ±10% 1/2W Carbon Film
R945	GT0516312-0	16K ohm ±5% 1/2W Carbon Film	R019	RC1027112-0	270 ohm ±10% 1/2W Carbon Film
R946	GT0516312-0	16K ohm ±5% 1/2W Carbon Film	R021	RT1056314-0	56K ohm ±10% 1/4W Carbon Film
C941-C944	DF1622301-0	0.022uF ±10% Mylar	C016	DK1810402-0	0.1uF +100, -0% Ceramic Cap.
J941-J948	57219520W-0	Lug Eyelet	C017	D00747353-0	0.047uF ±20% 600VDC Oil
P960	YD2578007-0	Comp Circuit PC Board	C003	DC1810201-0	0.001uF +100, -0% Feed Through
R961	RA0102001-0	1K ohm (B) Trimmer	C004	DC1103002-2	3PF ±0.5PF Fees Through
R962	RA0102001-0	1K ohm (B) Trimmer	C005	DD1105001-0	5PF ±0.5P Ceramic Cap.
H961	HD2000301-0	HR-5A Diode	C006	DK1710301-0	0.01uF ±20% Ceramic Cap.
H962	HD2000301-0	HR-5A Diode	C007	ED3360061-0	33uF 6.5W Electroly Cap.
H963	HV0000105-0	M8513 (R) Varistor	C008	DG0710450-0	0.1uF 150V ±20% MP. Cap.
H964	HD2000301-0	HR-5A Diode	C009	DG0710450-0	0.1uF 150V ±20% MP. Cap.
H965	HD2000301-0	HR-5A Diode	C010	EC4780502-0	4700uF 50V Electroly Cap.
H966	HV0000105-0	M8513 (R) Varistor	C011	EC4780502-0	4700uF 50V Electroly Cap.
H967	HT304581B-0	2SC458 (B) Transistor	C012	DG0710350-0	0.01uF ±20% 250V MP. Cap.
H968	HT304581B-0	2SC458 (B) Transistor	C013	DG0710350-0	0.01uF ±20% 250V MP. Cap.
J961-J964	57271240W-0	Lug Eyelet	C014	CA0330001-0	AM 3 Gang Variable
H001	HT7000410-0	SJ2001 (PNP) Transistor	C015	EA1070252-0	100uF 25V Electroly Cap.
H002	HT7000410-0	SJ2001 (PNP) Transistor	H006	HD2000305-0	M9235 Diode
H003	HT9000410-0	SJ2000 (NPN) Transistor	S001	SR0606006-0	For Function Rotary Switch
			S002	SP0401007-0	For Ant. Tuning Push Switch
			S003	SP0403001-2	S003-1 Muting S003-2 Main S003-3 Remote Push Switch
			S004	SP0401006-2	For AC Supply Push Switch
			S005	SS0202017-0	For FM-Ant. Attenuator Slide Switch
			J001-J003	YT0304003-0	4P For AM-FM Ant. For Main SP. For Remote SP. Terminal
			J004	YT0210001-0	For Phono Aux Tape Tape-out & in 10P Terminal
			J005	YJ0100055-0	For Dubbing Out Jack
			J006	YJ0100055-0	For Dubbing IN Jack
			J007	YJ0100055-0	For Headphone Jack
			J008	YJ0400032-0	For AC Supply Socket

REF. DESIG.	MARANTZ PART NO.	DESCRIPTION
J009	YJ0400032-0	For AC Supply Socket
J010	YJ0200007-0	For MPX Lamp Socket
J011	YJ0200007-0	For Ant Tuning Socket
J012	YJ0200007-0	For Meter Illumination Socket
J013	YJ0200007-0	For Meter Illumination Socket
J014	YJ0200038-0	For Dial Illumination Socket
J015	YJ0200039-0	For Dial Illumination Socket
J016	YJ0200040-0	For Dial Illumination Socket
J017	YJ0200041-0	For Dial Illumination Socket
J018	YT0101003-0	For Ground Terminal
J019	YJ0500014-0	For Power Transistor Socket
J020	YJ0500014-0	For Power Transistor Socket
J021	YJ0500014-0	For Power Transistor Socket
J022	YJ0500014-0	For Power Transistor Socket
J023	YL0107001-0	7P Terminal
J024	YL0107001-0	7P Terminal
J025	YL0107001-0	7P Terminal
J026	YL0107001-0	7P Terminal
J027	YL0105001-0	5P Terminal
J028	YL0105004-0	5P Terminal
J029	YL0103003-0	3P Terminal
J030	YL0103002-0	3P Terminal
J031	YL0103001-0	3P Terminal
J032	YL0103003-0	3P Terminal
M001	IM1103602-0	For AM-FM Tuning DC Meter
M002	IM1103603-0	For FM Tuning DC Meter
M003	IN1012004-0	MPX Lamp
M004	IN1008001-0	For Ant. Tuning Lamp
M005	IN1008001-0	For Meter Illumination Lamp
M006	IN1008001-0	For Meter Illumination Lamp
M007	IN1006003-0	For Dial Illumination Lamp
M008	IN1006003-0	For Dial Illumination Lamp
M009	IN1006003-0	For Dial Illumination Lamp
M010	IN1006003-0	For Dial Illumination Lamp
F001	FR1031001-0	3.15A Circuit Breaker
W001	YC0240006-0	For AC Supply AC Power Cord
W002	YW2578003-0	Wire Materials
L001	LF1140036-0	AM Ant Coil
L002	LB3007525-0	Balun
L003	LC1223001-0	Choke Coil
L004	LC2102001-0	2uH Ring Cord Choke Coil
L005	LC2102001-0	2uH Ring Cord Choke Coil
L006	TS6050101-0	Power Transformer
L007	LY2024003-0	24V DC Relay
R022	RT1010414-0	100K ohm $\pm 10\%$ 1/4W Carbon Film
P980	YD2578011-0	Speaker Protector PC Board
R981	RC1033212-0	3.3K ohm $\pm 10\%$ 1/2W Solid
R982	RT1056312-0	56K ohm $\pm 10\%$ 1/4W Solid
R983	RC1010412-0	100K ohm $\pm 10\%$ 1/2W Solid
R984	RC1027412-0	270K ohm $\pm 10\%$ 1/2W Solid
R985	RC1039312-0	39K ohm $\pm 10\%$ 1/2W Solid

REF. DESIG.	MARANTZ PART NO.	DESCRIPTION
R986	GS1010102-0	100 ohm $\pm 10\%$ 2W Wire Wound
R987	RC1056212-0	5.6K ohm $\pm 10\%$ 1/2W Solid
R988	RC1056212-0	5.6K ohm $\pm 10\%$ 1/2W Solid
T981	257711806-0	Spacer
C981	EA1060162-0	10uF 16V Electroly Cap.
C982	EA2270104-0	220uF 10V Electroly Cap.
C983	EA1060601-0	10uF 50V Electroly Cap.
H981	HT308282A-0	Transistor
H982	HT309842A-0	Transistor
H983	HT306962A-0	Transistor
H984	HD2000110-0	IS-1665 Diode
H985	HD2000110-0	IS-1665 Diode

J981-J987 YP1000036-0 Plug

NOTE :



marantz

MARANTZ CO., INC. • P.O. BOX 99 • SUN VALLEY, CALIFORNIA • 91352

●
A WHOLLY-OWNED SUBSIDIARY OF SUPERSCOPE INC., SUN VALLEY, CALIFORNIA 91352