



SERVICE  
MANUAL **2238**



**marantz**

model 2238

*Stereophonic Receiver*

## TABLE OF CONTENTS

Section	Title	Page
1.	SERVICE NOTES	1
2.	TEST EQUIPMENT REQUIRED FOR SERVICING	2
3.	AM ALIGNMENT PROCEDURE	2
3.1	AM IF Alignment	2
3.2	AM Frequency Range and Tracking Alignment	2
4.	FM ALIGNMENT PROCEDURE	2
4.1	FM Frequency Range and Tracking Alignment	2
4.2	Stereo Separation Alignment	3
4.3	Muting Threshold Adjustment	3
4.4	FM Dolby Level Adjustment	3
5.	POWER AMPLIFIER ADJUSTMENT	4
6.	POWER SUPPLY ADJUSTMENT	4
7.	VOLTAGE CONVERSION FOR EUROPEAN MODEL	4
8.	DIAGRAMS	5
8.1	Block Diagram	5
8.2	Inter Connection Diagram - U.S.A. & CANADA	7
8.3	Inter Connection Diagram - EUROPE	9
8.4	Schematic Diagram - U.S.A. & CANADA	11
8.5	Schematic Diagram - EUROPE	13
8.6	Tuner Board Schematic Diagram and Component Locations	15
8.7	FM Front End Board Schematic Diagram and Component Locations	19
8.8	Phono Equalizer Amp. Board Schematic Diagram and Component Locations	20
8.9	Main Amp. Board Schematic Diagram and Component Locations	22
8.10	Power Supply Board Schematic Diagram and Component Locations	24
8.11	Pre., Tone Amp. Board Schematic Diagram and Component Locations	25
8.12	Mono, Hi Filter, Tape 1 Mon., FM 25 $\mu$ S Switches Board Schematic Diagram and Component Locations	26
8.13	Mono, Hi Filter, Low Filter, Tape 1 Mon., Switches Board Schematic Diagram and Component Locations - EUROPE	26
8.14	Speaker Switch Board Schematic Diagram and Component Locations	27
8.15	Dial Lamp Board Schematic Diagram and Component Locations	27
9.	MAJOR COMPONENT LOCATIONS	28
9.1	Cabinet-Front View	28
9.2	Chassis-Top View	28
9.3	Cabinet-Rear View	29
9.4	Chassis-Bottom View	29
9.5	Cabinet-Front View - EUROPE	30
9.6	Chassis-Top View - EUROPE	30
9.7	Cabinet-Rear View - EUROPE	31
10.	EXPLODED VIEW	32
10.1	Packing Material Exploded View	32
10.2	Mechanical Exploded View	33
11.	PARTS LIST	35
12.	TECHNICAL SPECIFICATIONS	44



## INTRODUCTION

This service manual was prepared for use by Authorized Warranty Stations and contains service information for Marantz Model 2238 Stereophonic Receiver.

Servicing information and voltage data included in this manual are intended for use by the knowledgeable and experienced technician only. All instructions should be read carefully. No attempt should be made to proceed without a good understanding of the operations in the receiver.

The parts list furnishes information by which replacement parts may be ordered from the Marantz Company. A simple description is included for parts which can usually be obtained through local suppliers.

## 1. SERVICE NOTES

As can be seen from the circuit diagram, the chassis of Model 2238 consists of the following units. Each unit mounted on a printed circuit board is described within the square enclosed by a bold dotted line on the circuit diagram.

1. FM Front End . . . . . mounted on P.W. Board P100
2. Tuner . . . . . mounted on P.W. Board P200
3. Phono Equalizer Amp. . . . . mounted on P.W. Board P400
4. Main Amp. . . . . mounted on P.W. Board P700
5. Power Supply . . . . . mounted on P.W. Board P800
6. Pre & Tone Amp. . . . . mounted on P.W. Board PE01
7. Mono, Hi Filter, Tape 1 Monitor &  
FM 25 $\mu$ S Switches . . . . . mounted on P.W. Board PH01
8. Speaker Switch . . . . . mounted on P.W. Board PT01
9. Dial Lamp . . . . . mounted on P.W. Board PZ01

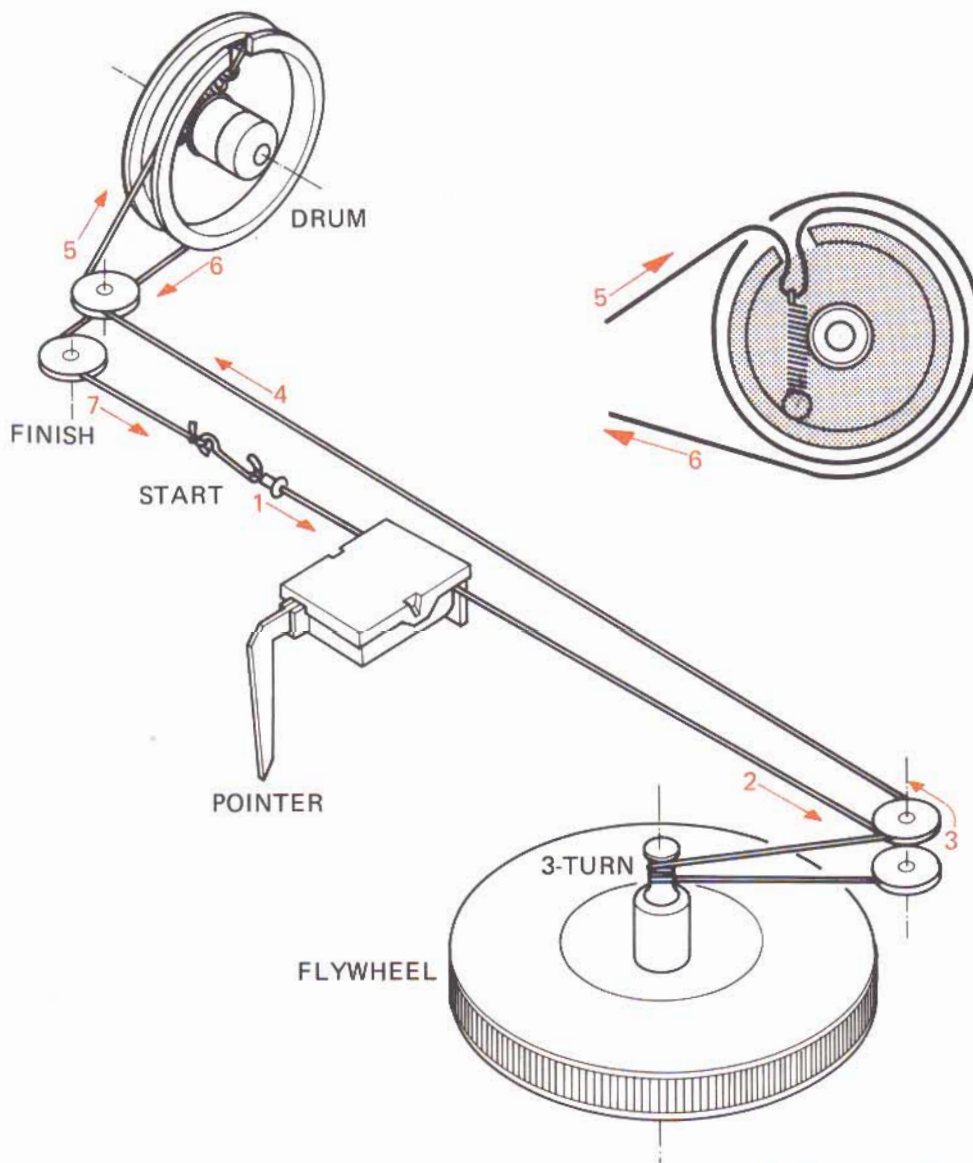

Figure 1. Dial Stringing

## 2. TEST EQUIPMENT REQUIRED FOR SERVICING

This table lists the test equipment required for servicing the Model 2238 Receiver.

Item	Manufacturer and Model No.	Use
AM Signal Generator		Signal source for AM alignment
Test Loop		Use with AM Signal Generator
FM Signal Generator MPX Signal Generator	Sound Technology Model 1000A	Signal source for FM alignment Stereo separation alignment and trouble shooting
Distortion Analyzer Audio Oscillator AC VTVM	Sound Technology Model 1700A	Distortion measurements Sinewave and squarewave signal source Voltage measurements (AC)
Oscilloscope	Tektronix Model T932 Philips Model 3232	Waveform analysis and trouble shooting and ASO alignment
Frequency Counter	Fluke Model 1900A	MPX Oscillator adjustment (VCO)
Circuit Tester		Trouble shooting
DC VTVM	Fluke Model 8000 "Digital" Simpson Model 313, Triplet Model 801	Voltage measurements (DC)
AC Wattmeter	Simpson Model 1379	Monitors primary power to amplifier
AC Ammeter	Commercial Grade (1-10A)	Monitors amplifier output under short circuit condition
Line Voltmeter	Simpson Model 1359	Monitors potential of primary power to amplifier
Variable Autotransformer	Superior Electronic Co., Powerstat Model 116B-10A	Adjusts level of primary power to amplifier
Shorting Plug	Use phono plug with 600-ohm across center pin and shell	Shorts amplifier input to eliminate noise pickup
Output Load (8 ohms, 0.5%, 100W)	Commercial Grade	Provides 8-ohm load for amplifier output termination
Output Load (4 ohms, 0.5%, 100W)	Commercial Grade	Provides 4-ohm load for amplifier output termination

## 3. AM ALIGNMENT PROCEDURE

### 3.1 AM IF ALIGNMENT

1. Connect a sweep generator to the L153 and an alignment scope to the resistor R162 (out side).
2. Rotate each core of IF transformers L155 and L156 for the maximum height and flat top symmetrical response.

### 3.2 AM FREQUENCY RANGE AND TRACKING ALIGNMENT

1. Set AM signal generator to 515 kHz. Turn the tuning capacitor fully closed (place the tuning pointer at the low end) and adjust the oscillator coil L154 for maximum audio output.
2. Set the signal generator to 1650 kHz. Place the tuning pointer in the high frequency end and adjust the oscillator trimmer on the oscillator tuning capacitor for maximum audio output.
3. Repeat steps 1 and 2 until no further adjustment is necessary.
4. Set the generator to 600 kHz, tune the receiver to the same frequency and adjust a slug core of AM ferrite-rod antenna L001 for maximum output.

5. Set the generator to 1400 kHz and tune the receiver to the same frequency and adjust the trimming capacitor on the antenna tuning capacitor for maximum output.
6. Repeat procedures 4 and 5 until no further adjustment is necessary.

**NOTE:** During tracking alignment reduce the signal generator output as necessary to avoid AGC action.

## 4. FM ALIGNMENT PROCEDURE

### 4.1 FM FREQUENCY RANGE AND TRACKING ALIGNMENT

1. Connect an FM signal generator to the FM antenna terminals and an oscilloscope and an audio distortion analyzer to the TAPE OUT jacks on the rear panel.
2. Set the generator to 87.4 MHz and provide about 3 to 5  $\mu$ V. Place the tuning pointer at the low frequency end by rotating the tuning knob and adjust the pitch of oscillator coil L107 to obtain maximum audio output.



3. Set the generator to 109 MHz and provide about 3 to 5  $\mu\text{V}$ . Rotate the tuning knob and place the tuning pointer at the high frequency end and adjust the trimming capacitor C121 for maximum output.
4. Repeat steps 2 and 3 until no further adjustment is necessary.
5. Set the generator to 90 MHz and tune the receiver to the same frequency. Decrease signal generator output until the audio output level decreases with the decreasing generator output. Adjust the pitch of antenna coil L102 and RF coil L104 for maximum output.
6. Set the generator to 106 MHz and tune the receiver to the same frequency. Decrease the signal generator output until the audio output level decreases with the decreasing generator output. Adjust the trimming capacitors of antenna and RF tuning circuits for maximum output.
7. Repeat steps 5 and 6 until no further adjustment is necessary.
8. Adjust the primary core (lower core) of discriminator transformer L202 so that the center tuning meter pointer indicates its center at no signal applied. Set the FM signal generator to 98 MHz and increase its output level 1  $\text{K}\mu\text{V}$  and tune the receiver to the same frequency so that the center tuning meter pointer indicates its center. Adjust the secondary core (upper core) of L202 for minimum distortion.

#### 4.2 STEREO SEPARATION ALIGNMENT

1. Set the FM signal generator to provide 1  $\text{K}\mu\text{V}$  at 98 MHz. Tune the receiver to the same frequency so that the center tuning meter pointer indicates its center. Then turn off the modulation of the generator, connect a frequency counter to test point J229 and adjust R301 so that the frequency counter may precisely read 76 kHz.
2. Modulate the generator with stereo composite signal consisting of only L or R channel (of course a pilot signal must be included).
3. Adjust the trimming resistor R317 for maximum and same separation in both channels.

#### 4.3 MUTING THRESHOLD ADJUSTMENT

1. Set the FM signal generator output to provide 12.5  $\mu\text{V}$  (IHF) at 98 MHz and tune receiver to the same frequency. Adjust the trimming resistor R212 for the threshold level of 12.5  $\mu\text{V}$ . (During this adjustment turn the FM MUTING pushswitch "on".)

#### 4.4 FM DOLBY LEVEL ADJUSTMENT

1. Set the FM signal generator to provide a 400 Hz, 50% modulated 98 MHz mono signal, at 1  $\text{K}\mu\text{V}$  output. Precisely tune the receiver to 98 MHz.
2. Depress the FM 25  $\mu\text{S}$  pushswitch, and adjust R215 until the outputs of both channels are 580 mV.

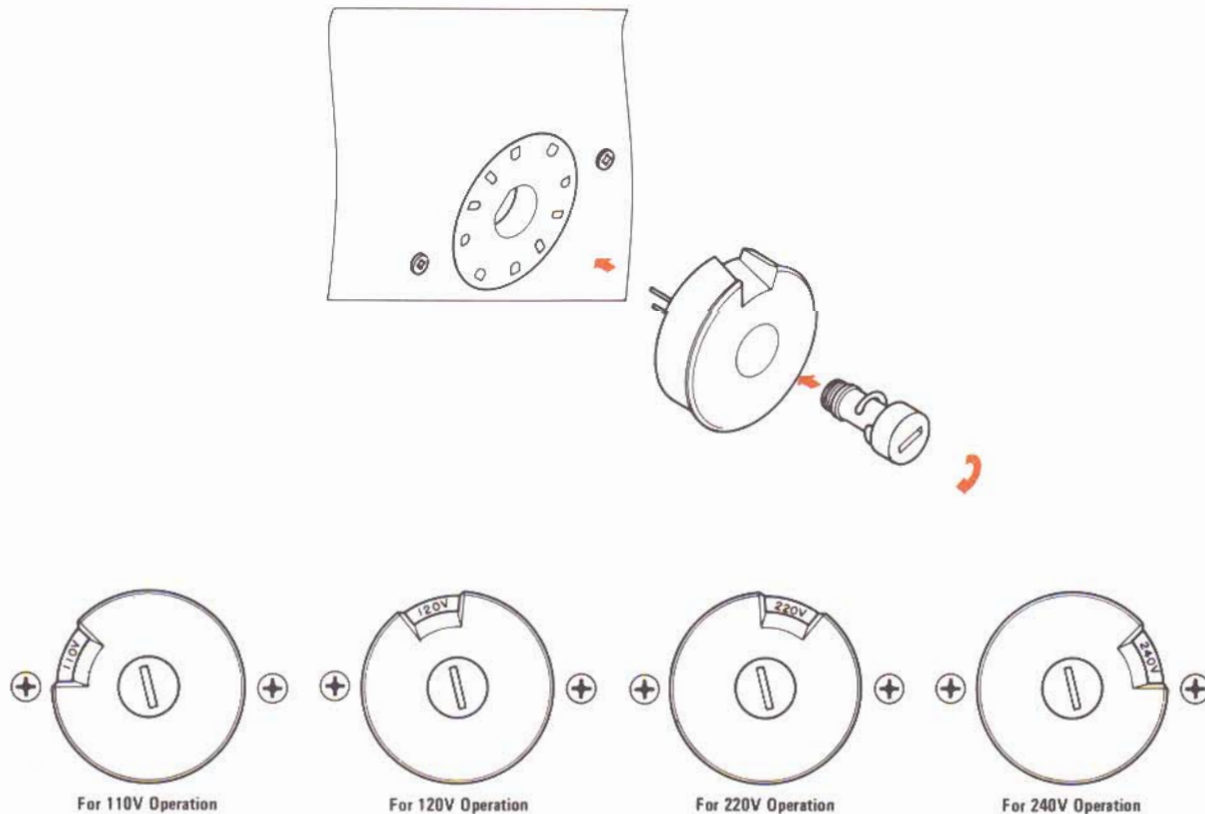

Figure 2. Voltage Conversion Chart

## 5. POWER AMPLIFIER ADJUSTMENT

Connect a VTVM between J714(+) and J716(-) and adjust the trimming resistor R733 until the VTVM reads 14 mV DC. And next, connect a VTVM between J723 and J722 (GROUND) and adjust the trimming resistor R711 until the VTVM reads 0 mV DC. Do over again. For the other channel, connect the VTVM between J715(+) and J717(-) and adjust the R734 for the same reading, and connect the VTVM between J724 and J722 and adjust the R712 for the same reading. Do over again.

## 6. POWER SUPPLY ADJUSTMENT

Connect a VTVM between J805(+) and J814(-) and adjust R808 until the VTVM reads 35.0 V under no signal condition.

## 7. VOLTAGE CONVERSION FOR EUROPEAN MODEL

The European version of the Model 2226 is equipped with a universal power transformer that may be adjusted to operate at 110V, 120V, 220V, or 240V AC at 50 to 60 Hz. To convert the unit to a different power source voltage, reposition conversion plug as shown in Figure 2.

**CAUTION: DISCONNECT POWER SUPPLY CORD FROM AC OUTLET BEFORE CONVERTING VOLTAGE.**

## FTZ REGULATION

Instruction for the use in the range other than specified in FTZ codes

**Achtung für die Leute, die in dem Gebiet wohnen, wo die FTZ-Bestimmungen vorherrschend sind.**

Sollte das Gerät auch für Frequenzen ausserhalb des in den FTZ-Bestimmungen angegebenen Bereiches empfangebereit sein, bitten wir, den Bereich durch Nachstellen des Kernes in der Oszillatorspule (in der Abbildung mit "FTZ" gekennzeichnet) so zu korrigieren, dass er den Bestimmungen entspricht.



# 8. DIAGRAMS

## 8.1 BLOCK DIAGRAM

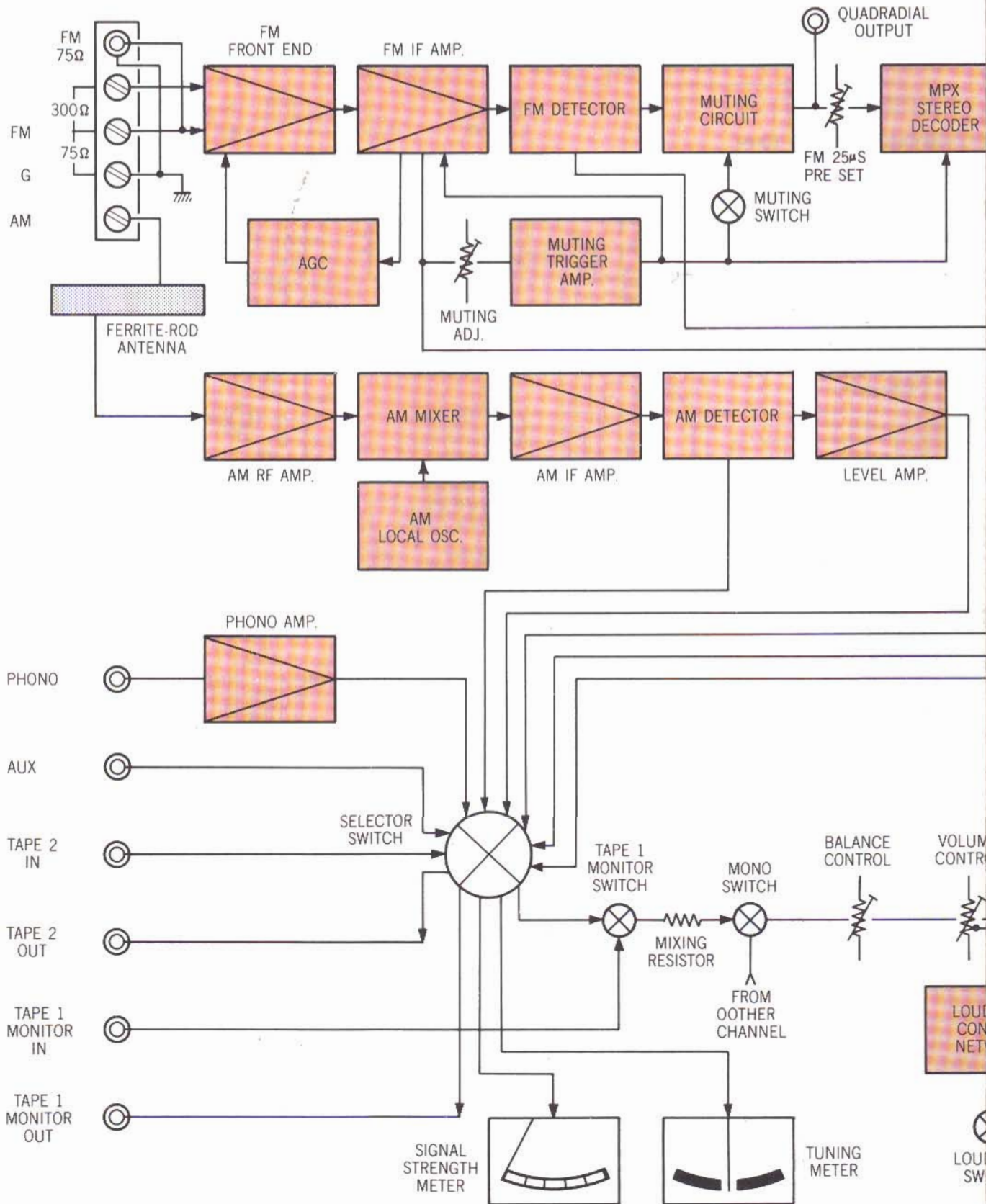

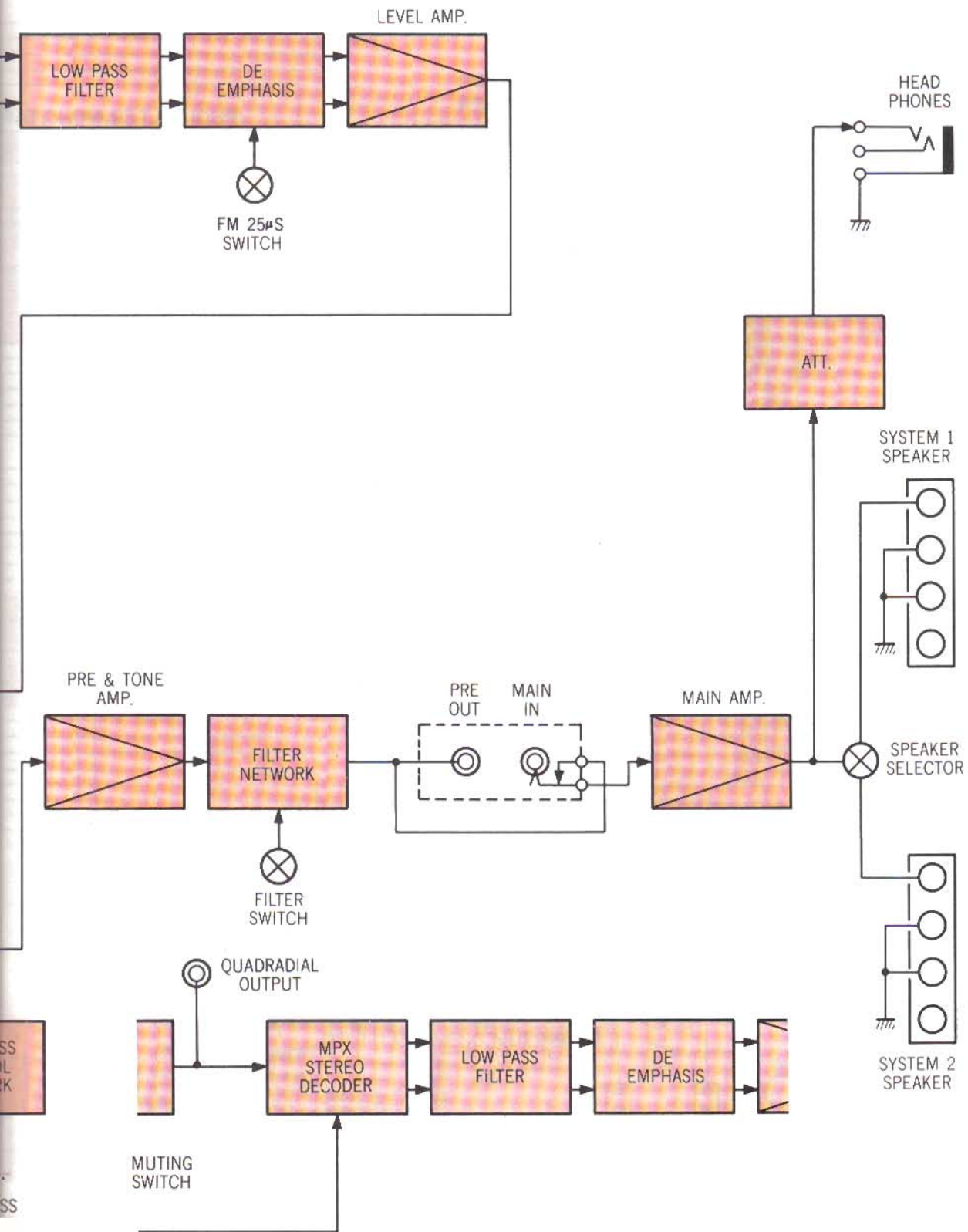



8.2 INTER CONNECTION DIAGRAM - U.S.A. & CANADA

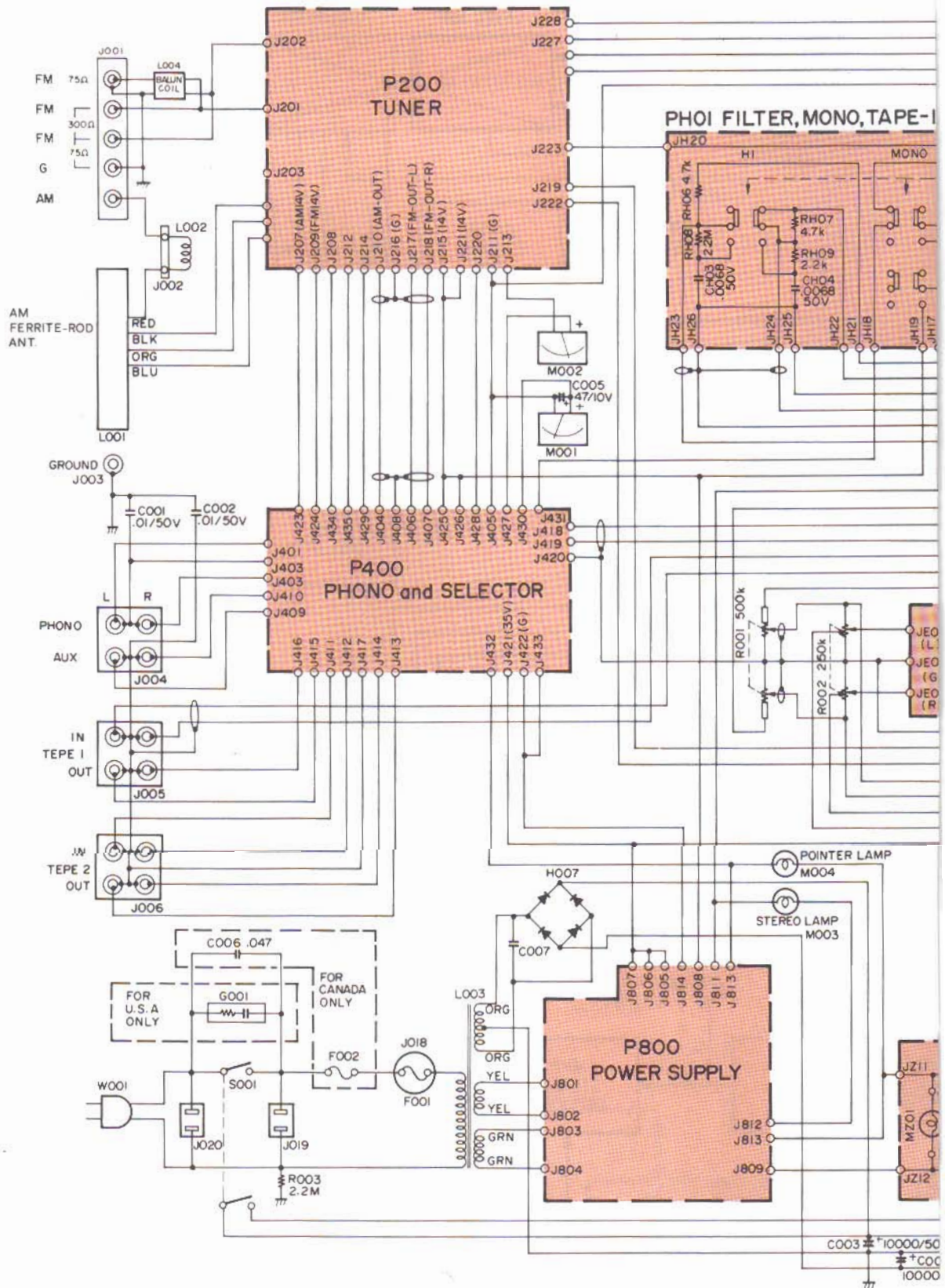

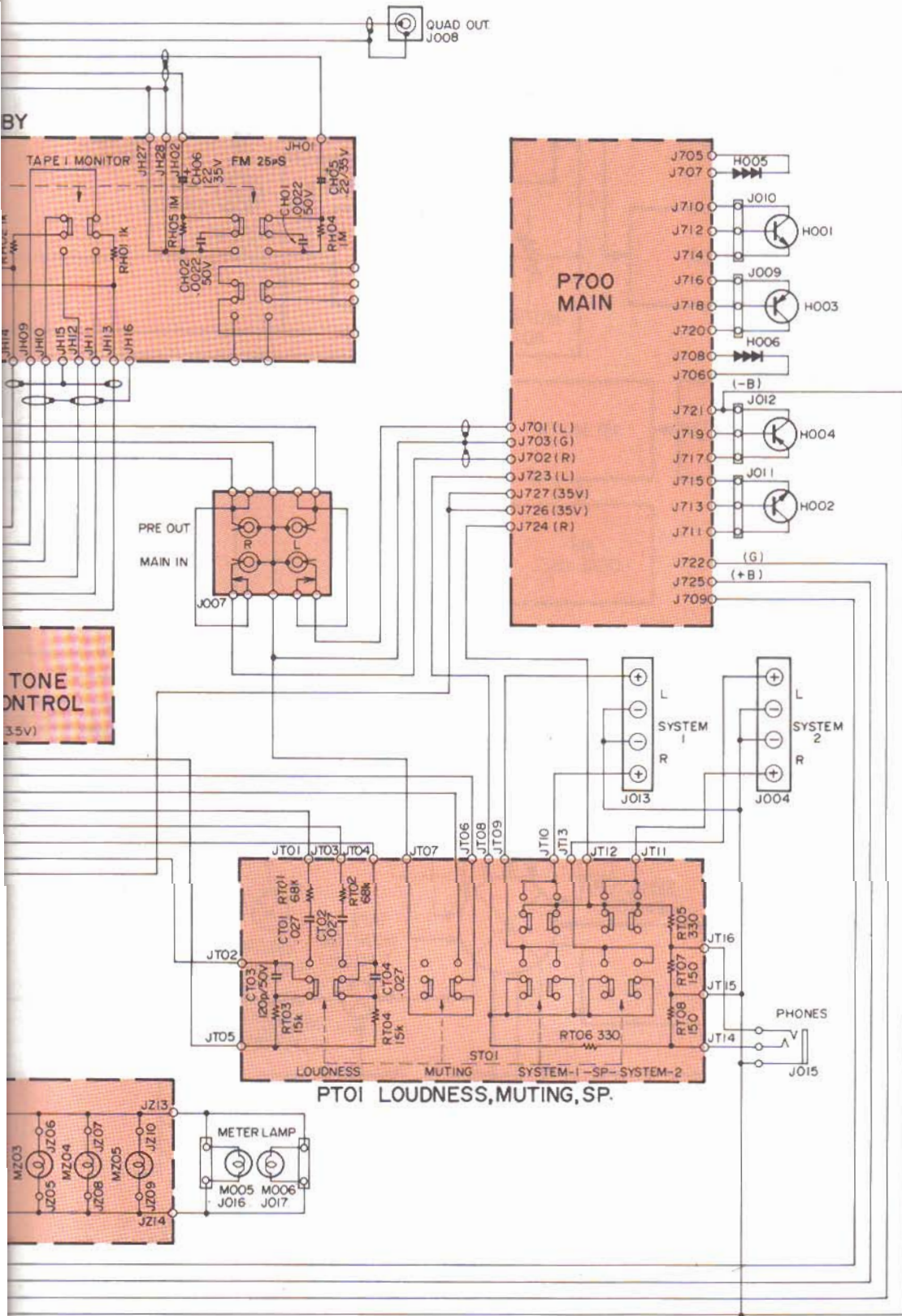



### 8.3 INTER CONNECTION DIAGRAM - EUROPE

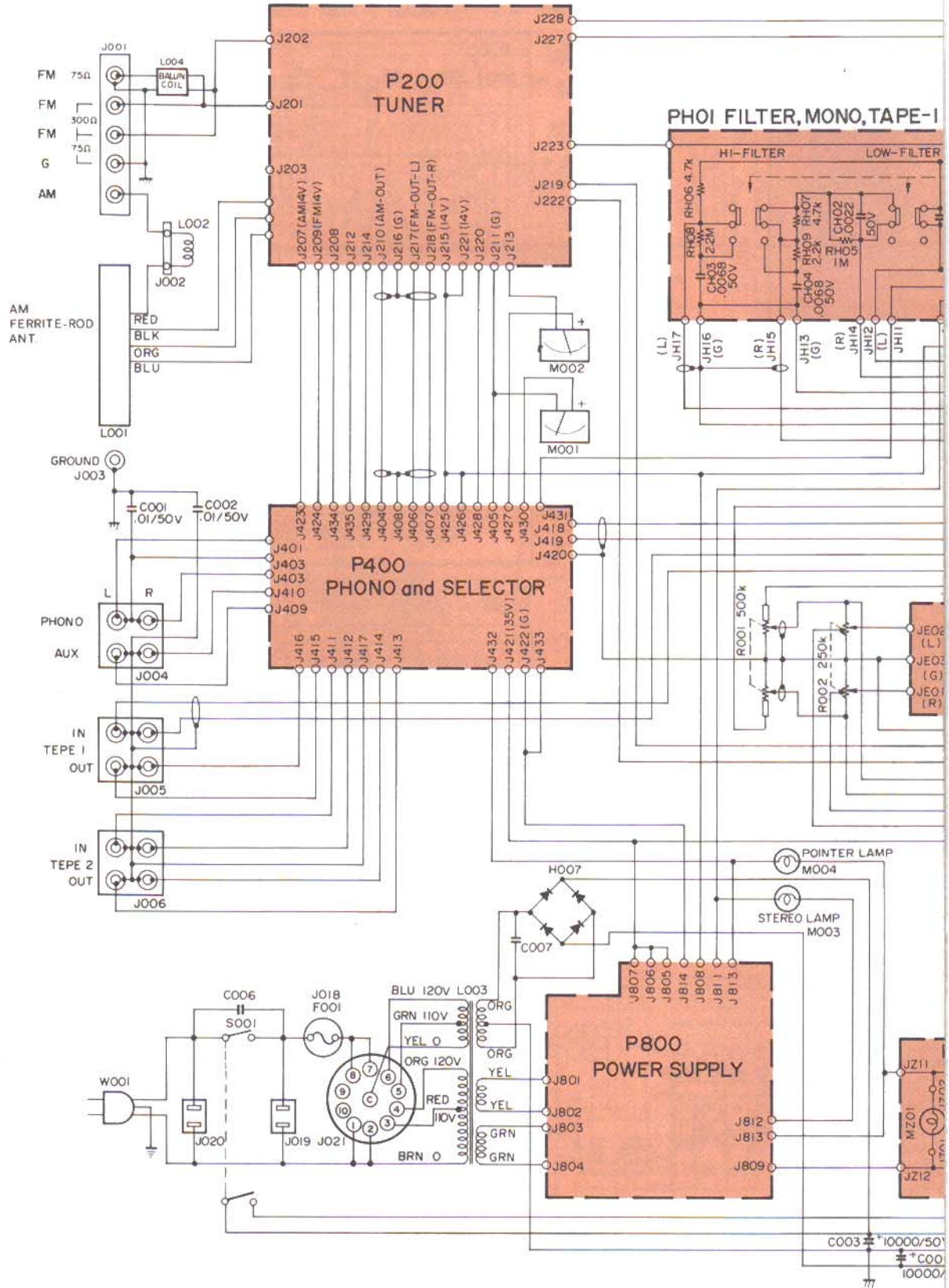

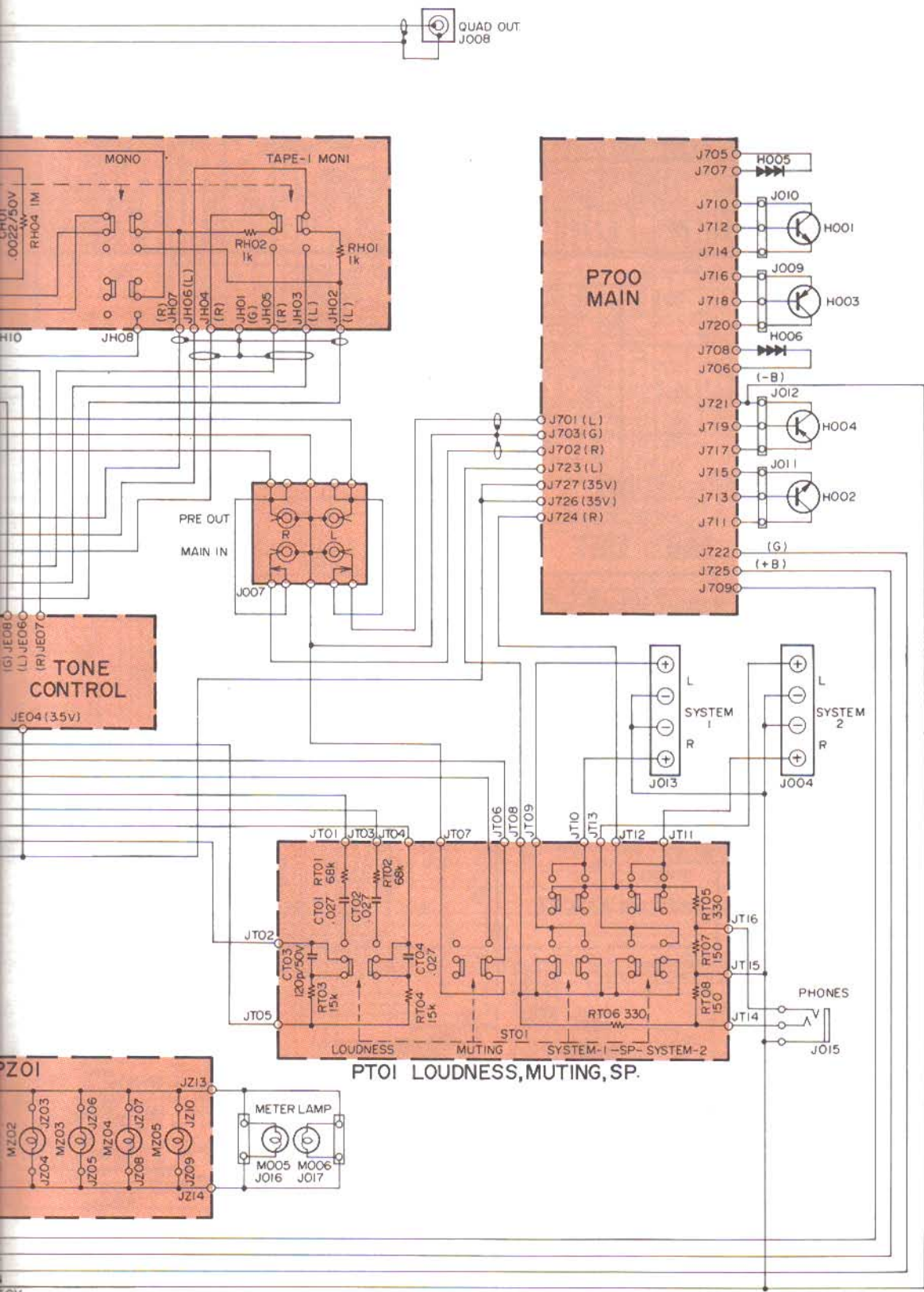



## 8.4 SCHEMATIC DIAGRAM - U.S.A. & CANADA

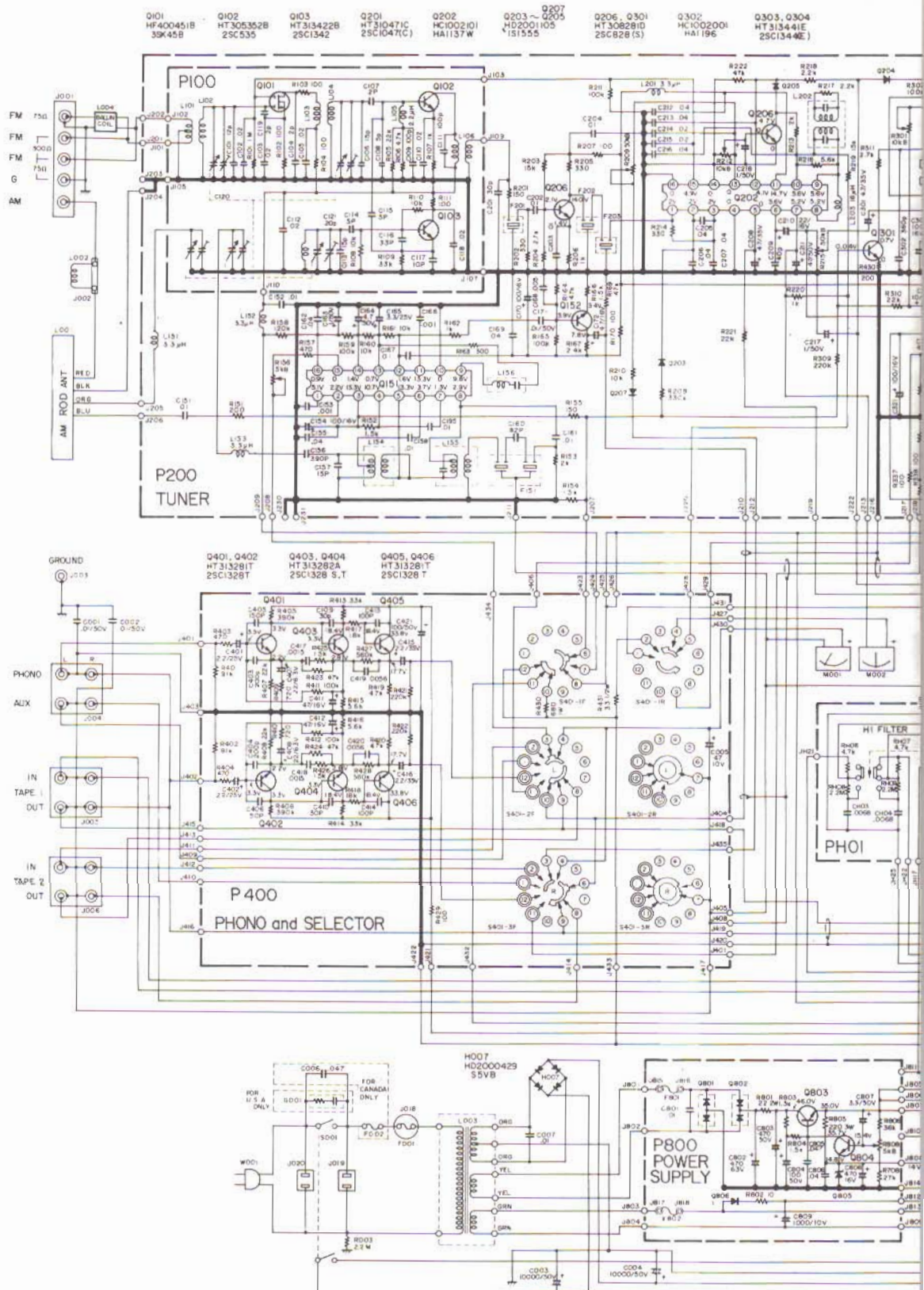



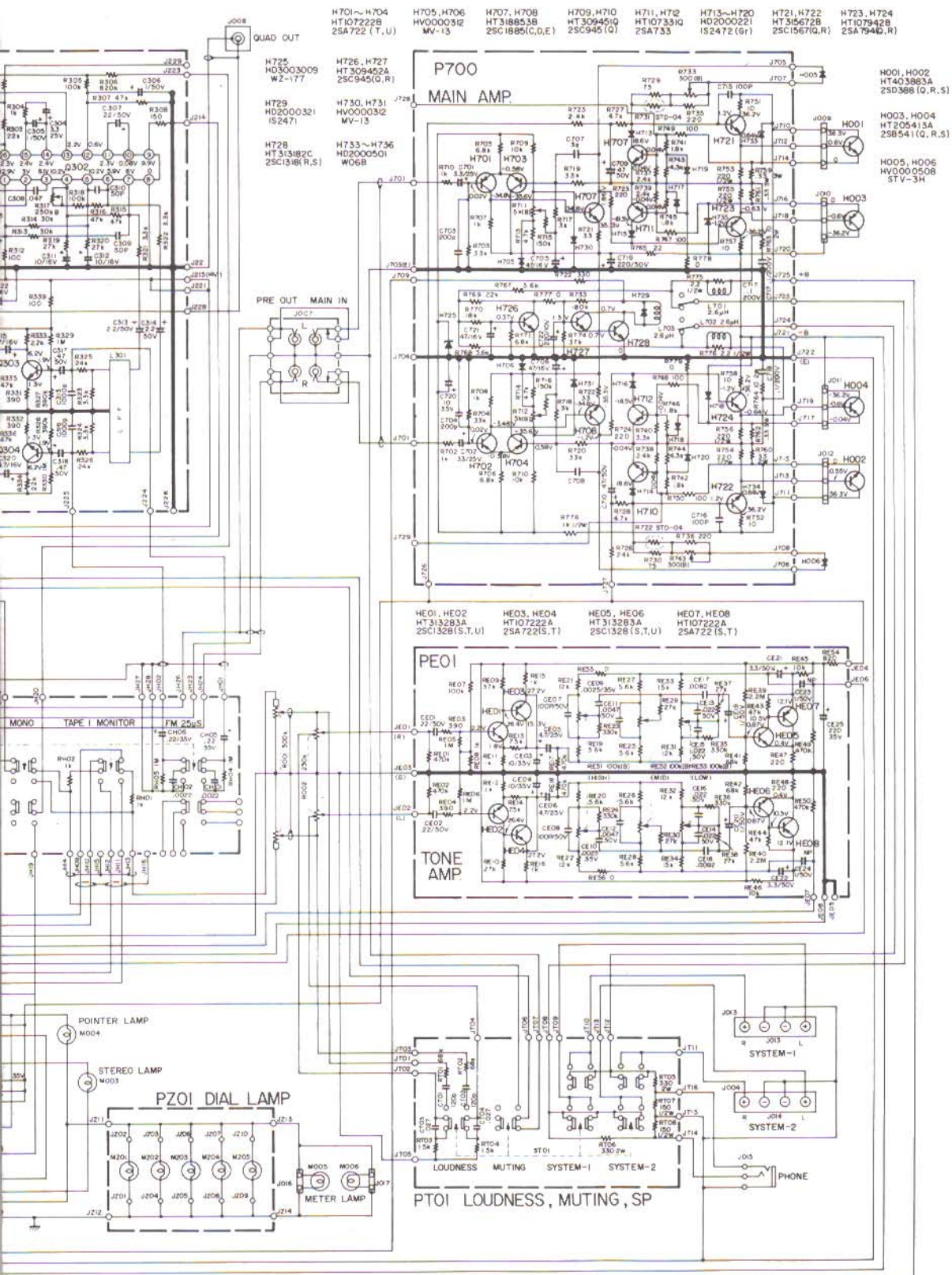

Q805 HD3002109 BZ-40  
Q806 HD2000413 S1B01-02



# 8.5 SCHEMATIC DIAGRAM - EUROPE

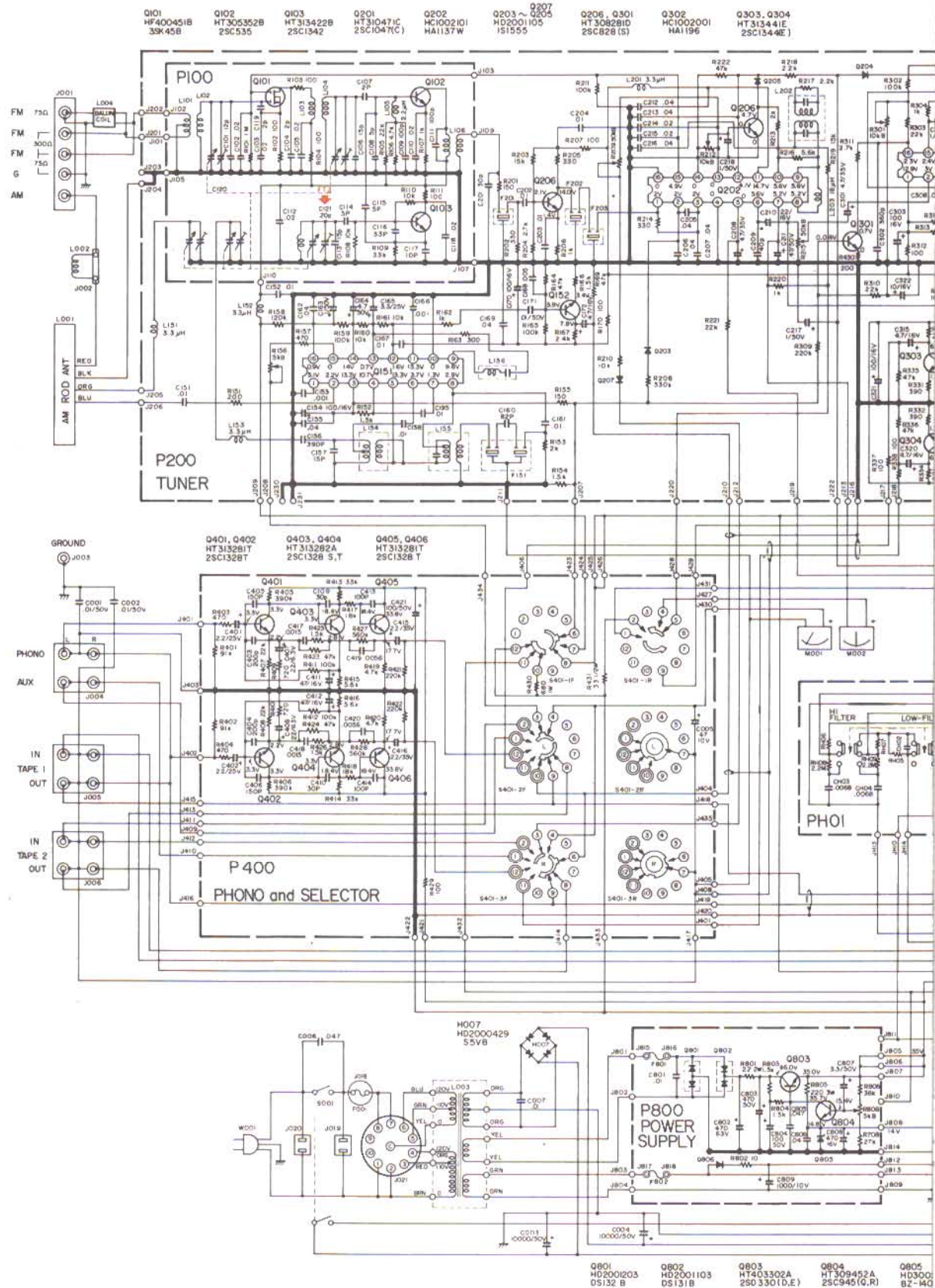

- Q801  
HD2001203  
DS132 B
- Q802  
HD2001103  
DS131 B
- Q803  
HT403302A  
250 330(D.E.)
- Q804  
HT309452A  
250 945(G.R.)
- Q805  
HD3001  
BZ-140



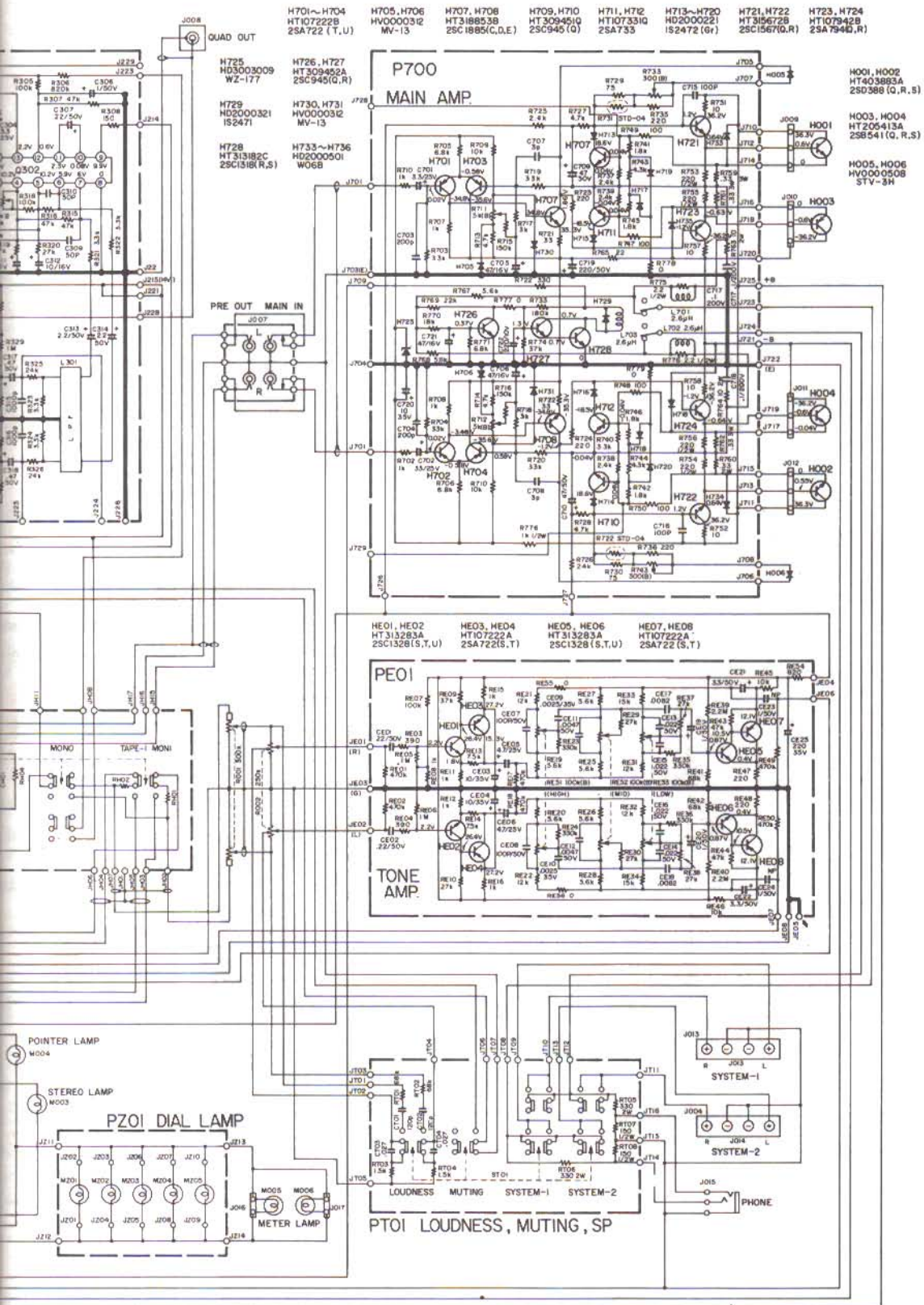

Q806  
HD2000413  
S1801-02



8.6 TUNER BOARD SCHEMATIC DIAGRAM AND COMPONENT LOCATIONS

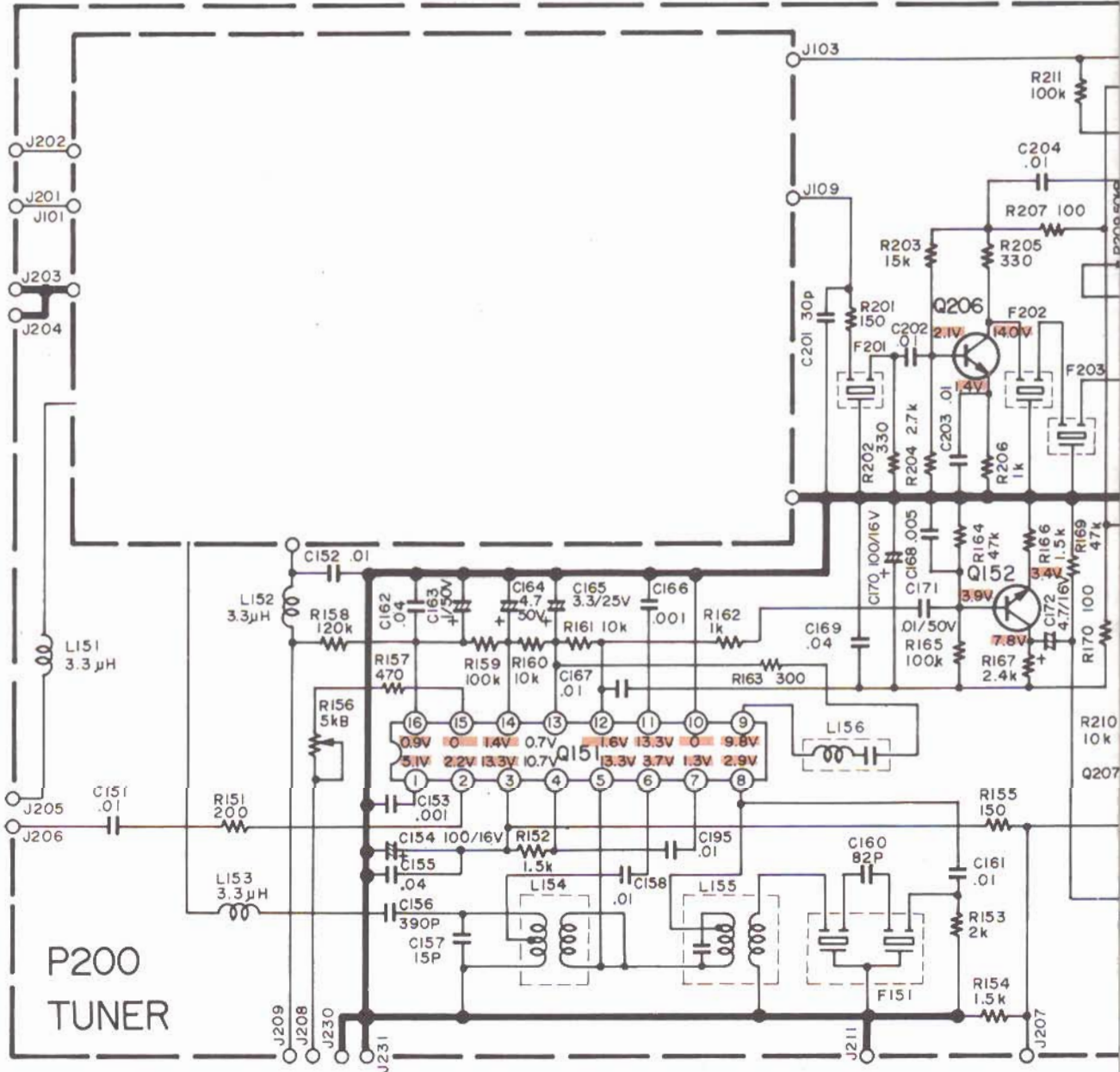

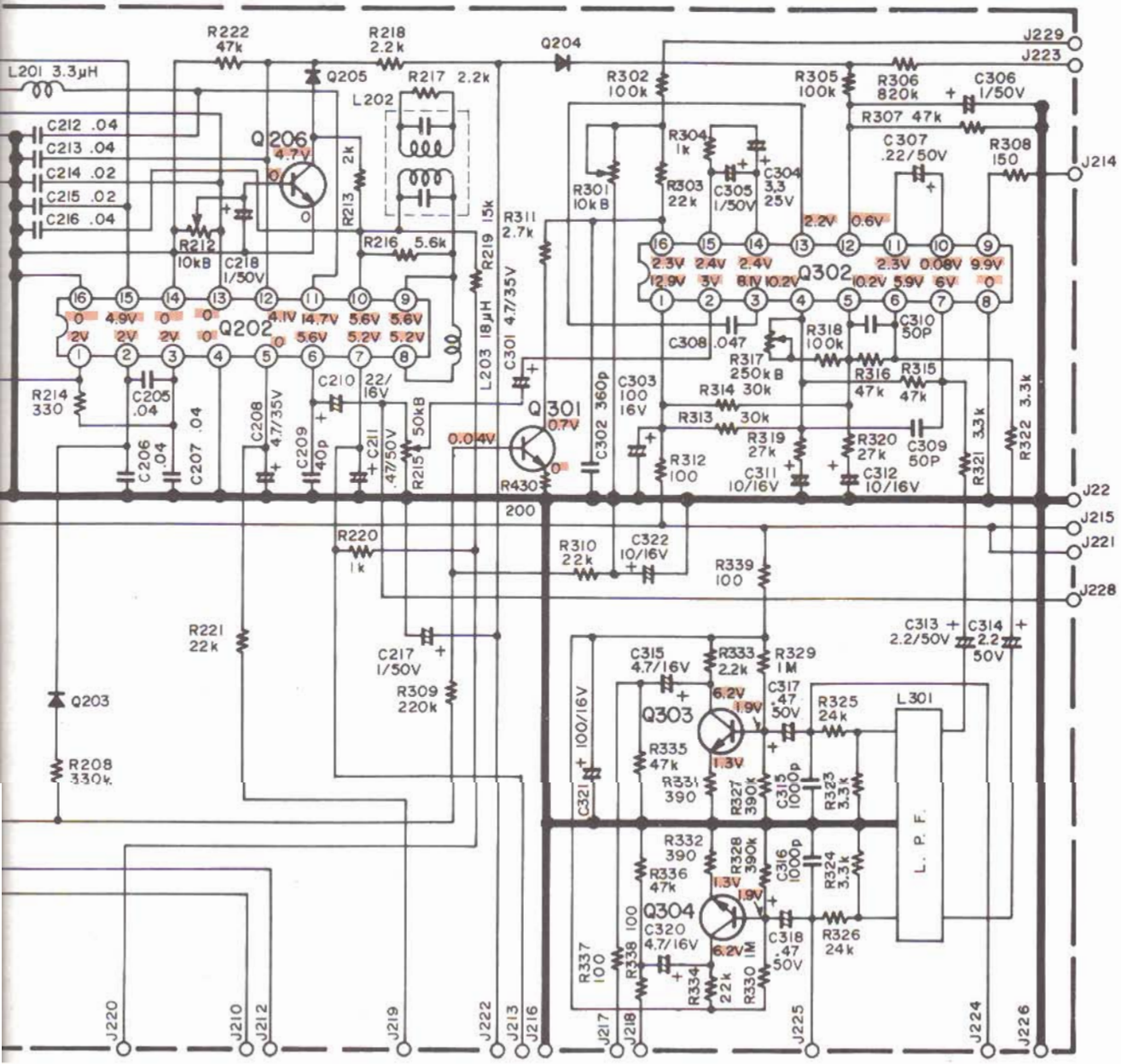



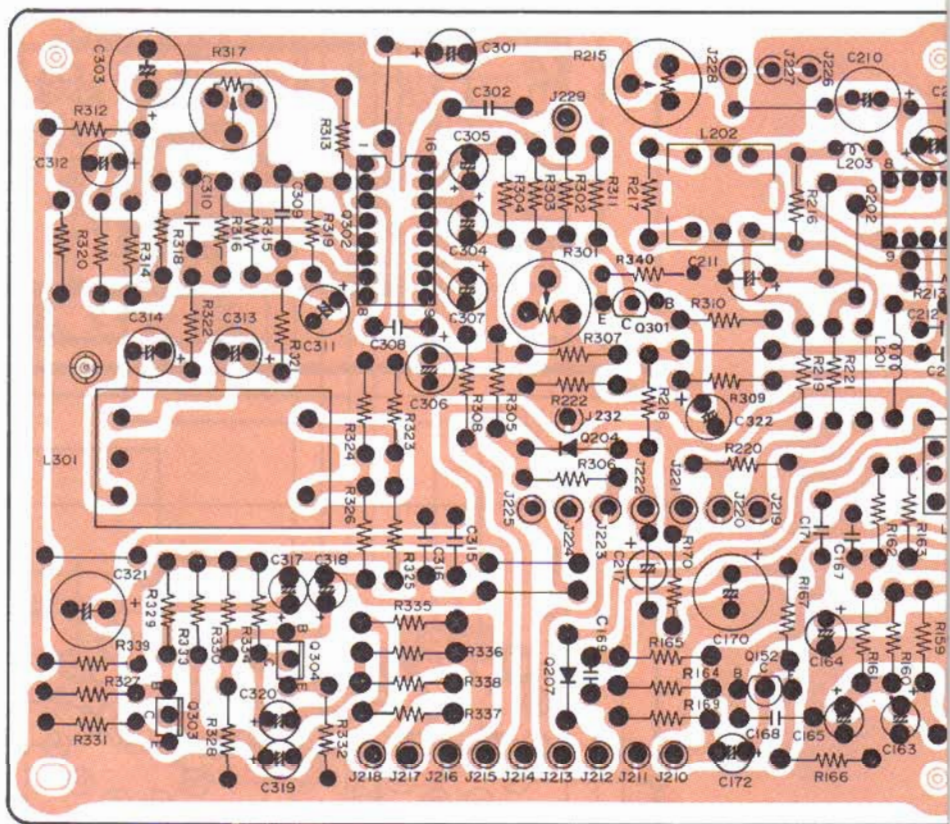

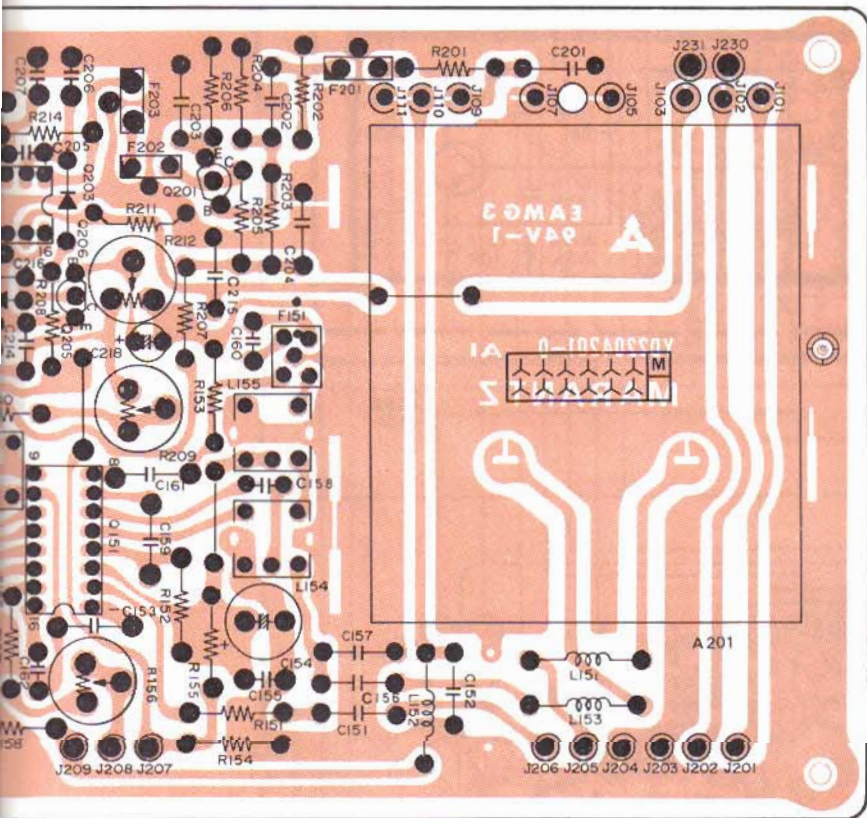



8.7 FM FRONT END BOARD SCHEMATIC DIAGRAM AND COMPONENT LOCATIONS

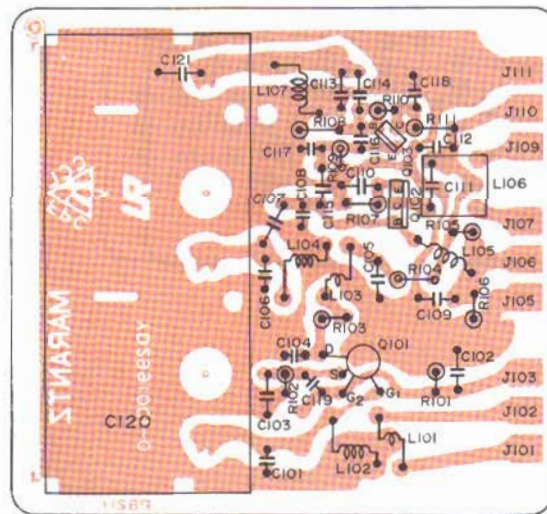
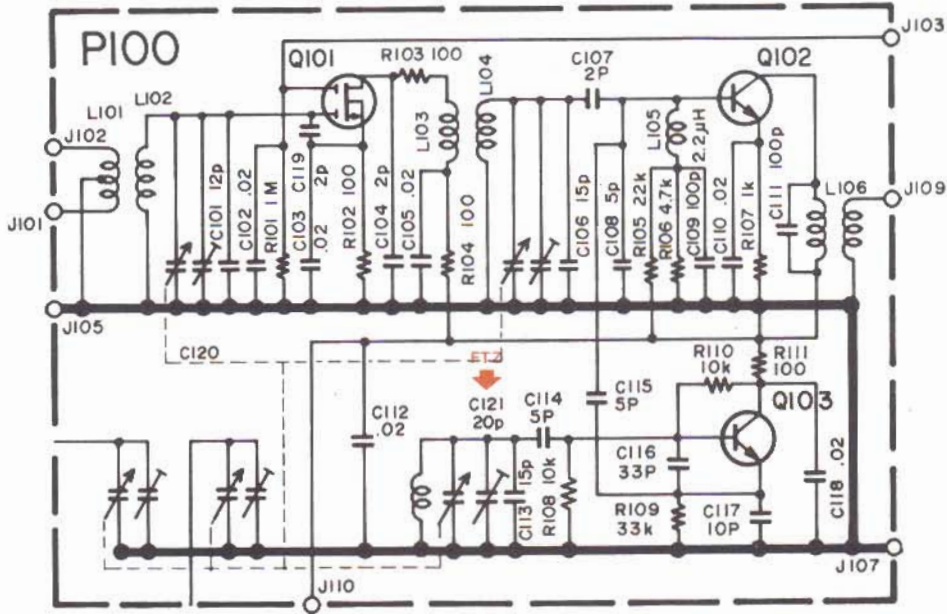

8.8 PHONO EQUALIZER AMP. BOARD SCHEMATIC DIAGRAM AND COMPONENT LOCATIONS

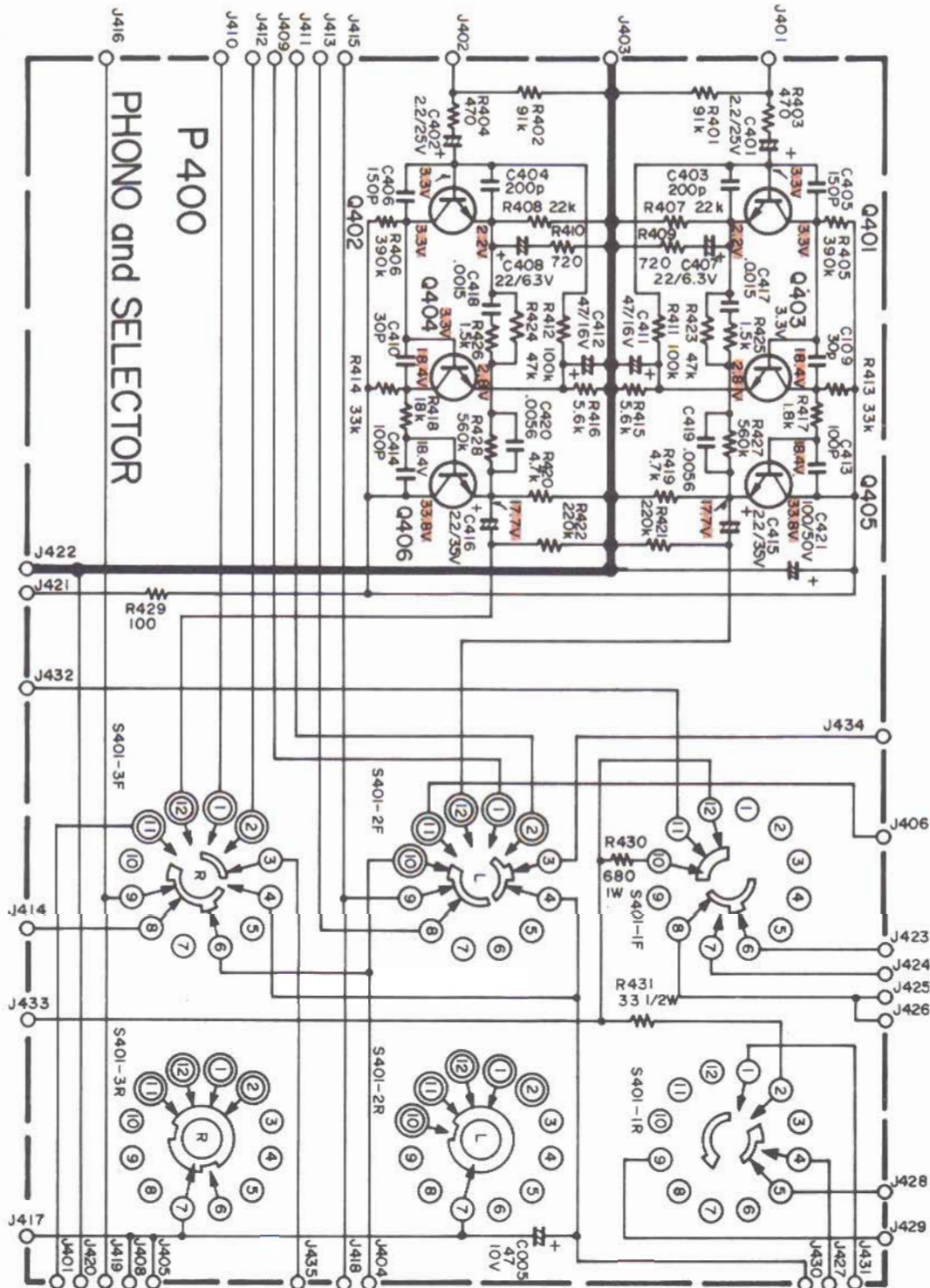



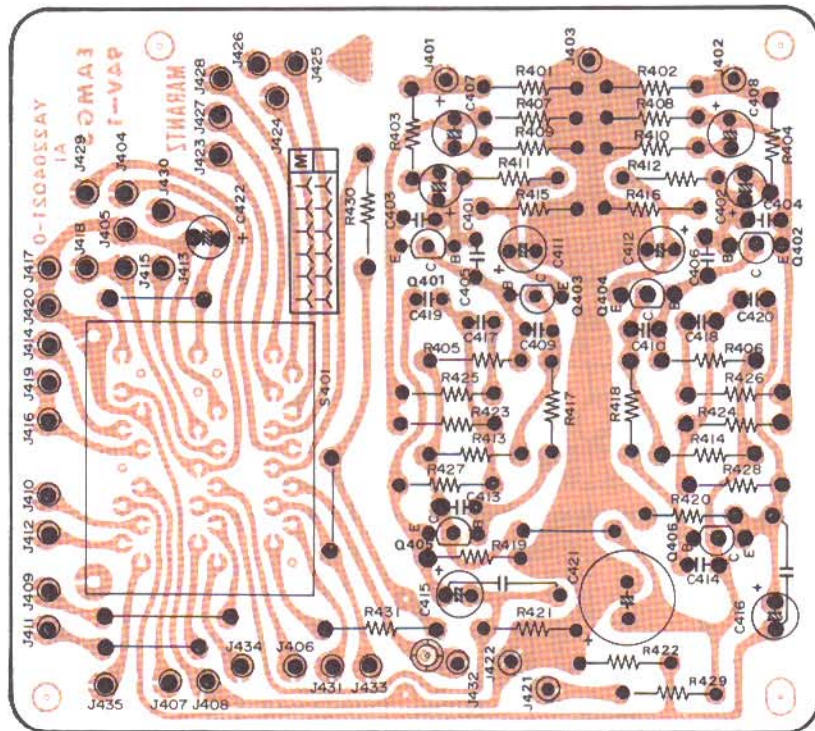

8.9 MAIN AMP. BOARD SCHEMATIC DIAGRAM AND COMPONENT LOCATIONS

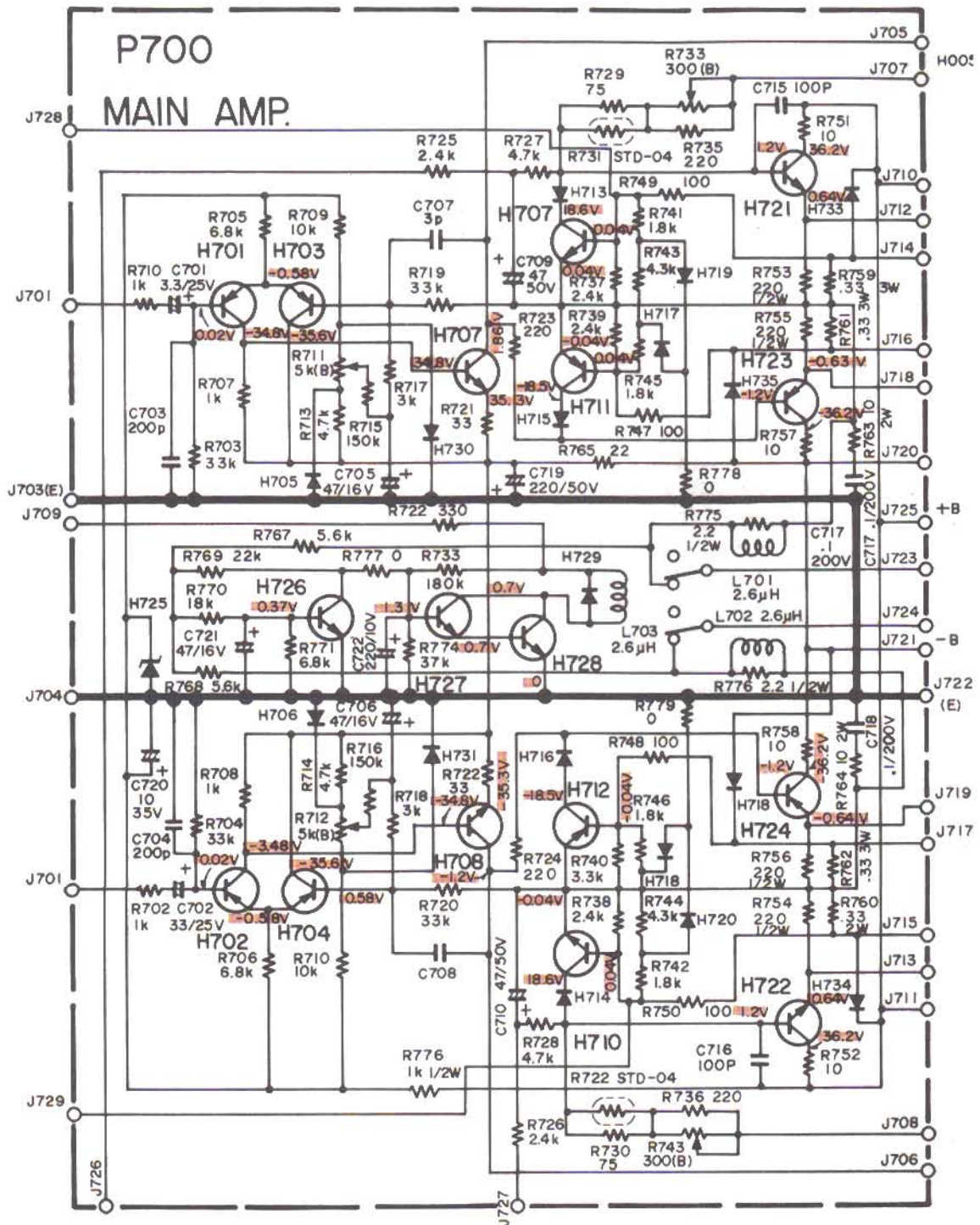



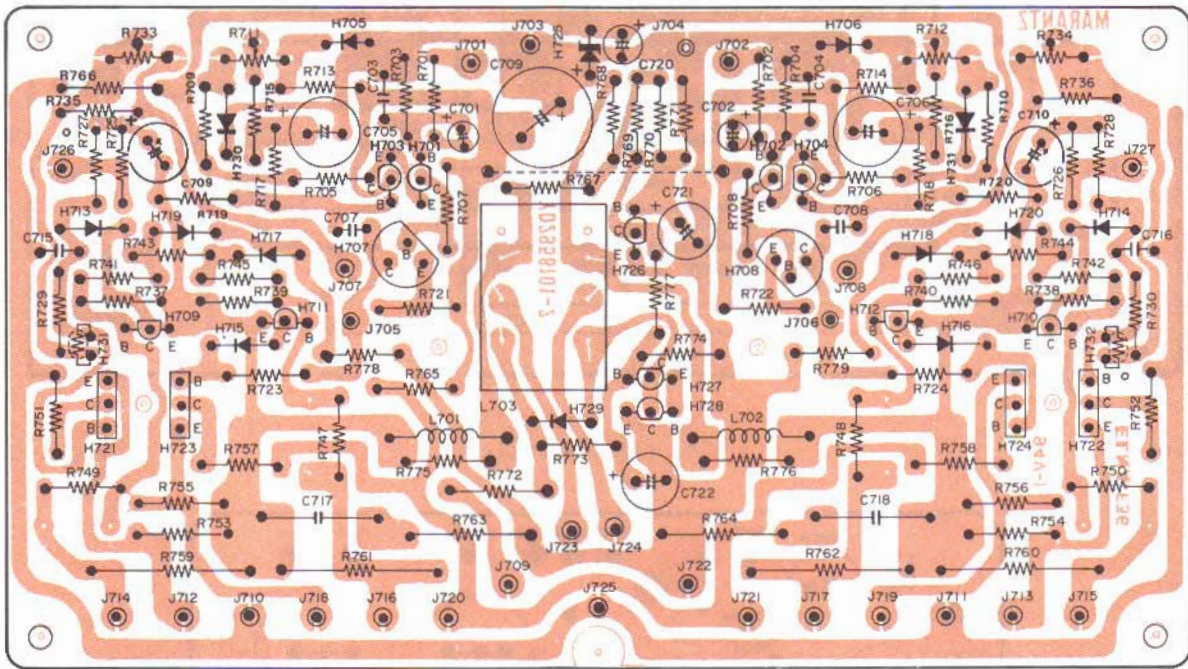

8.10 POWER SUPPLY BOARD SCHEMATIC DIAGRAM AND COMPONENT LOCATIONS

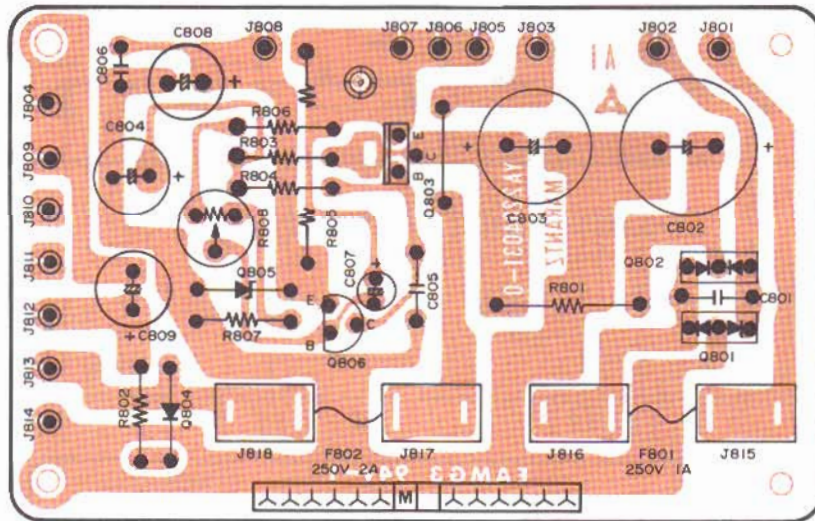
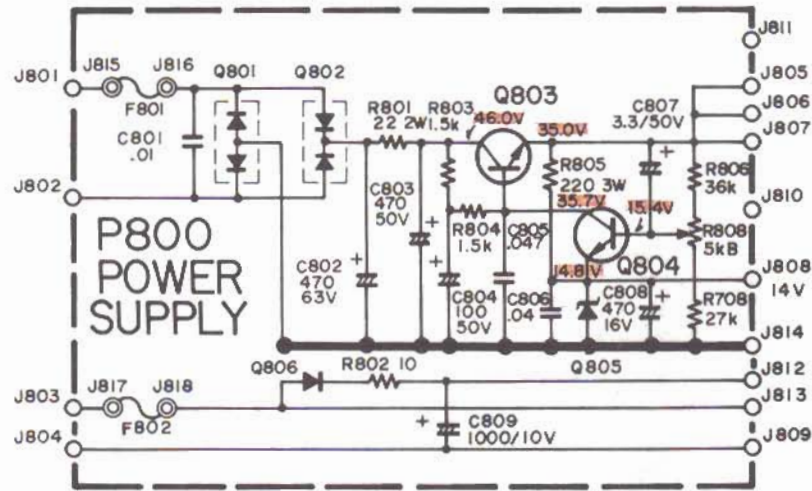



8.11 PRE, TONE AMP. BOARD SCHEMATIC DIAGRAM AND COMPONENT LOCATIONS

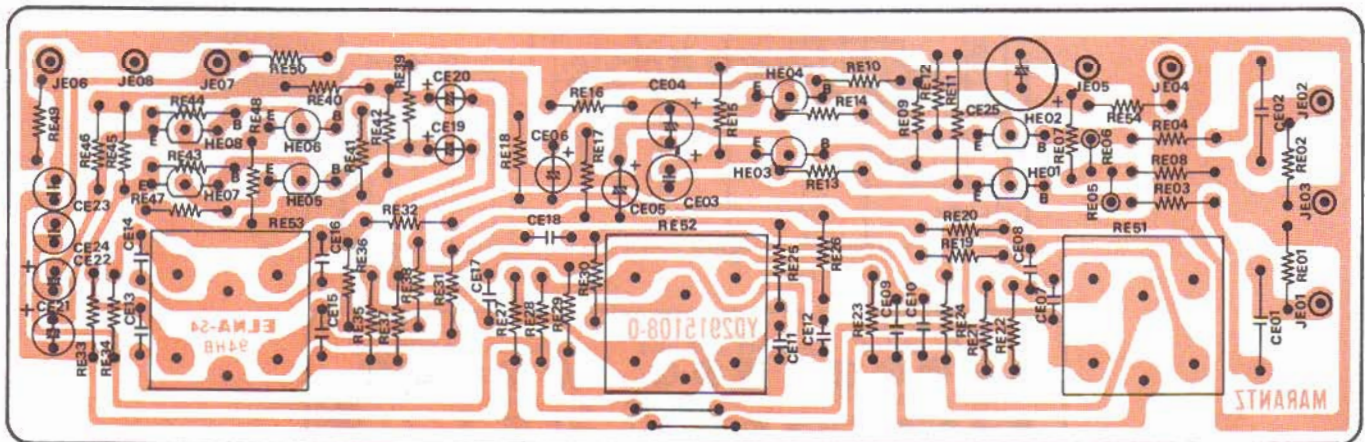
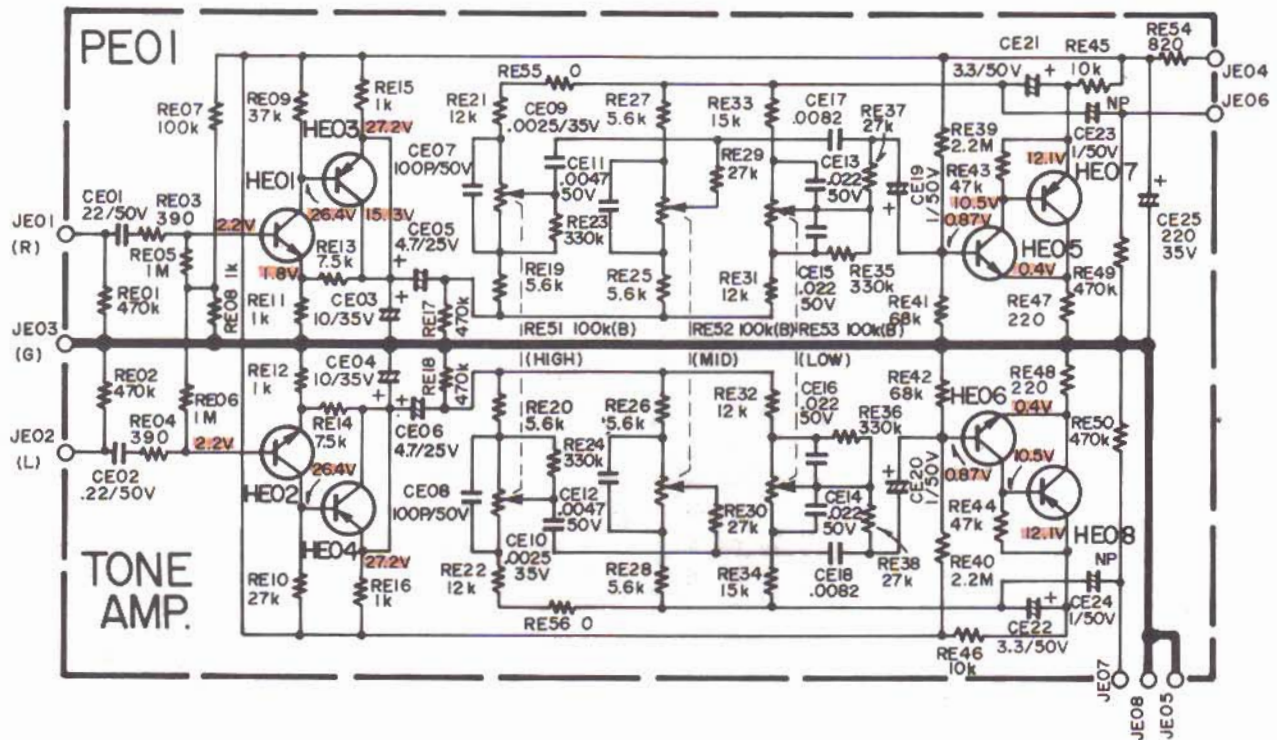

8.14 SPEAKER SWITCH BOARD SCHEMATIC DIAGRAM AND COMPONENT LOCATIONS

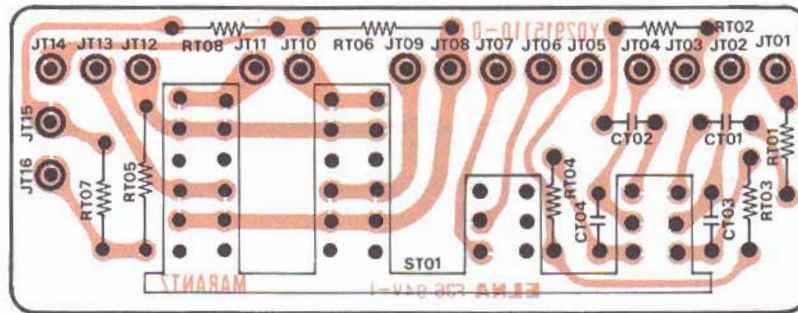
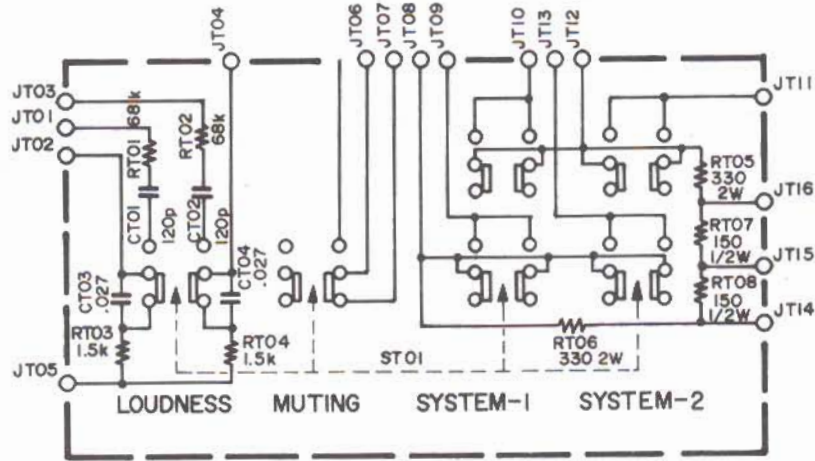

8.15 DIAL LAMP BOARD SCHEMATIC DIAGRAM AND COMPONENT LOCATIONS

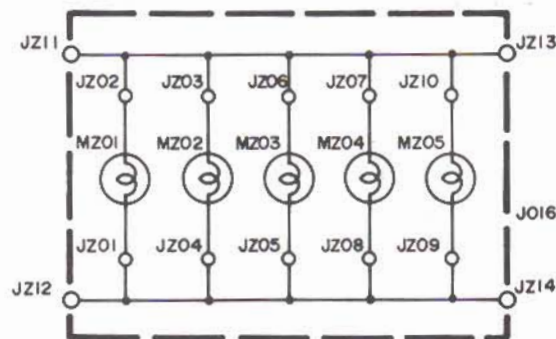



**9. MAJOR COMPONENT LOCATIONS**

**9.1 CABINET - FRONT VIEW**

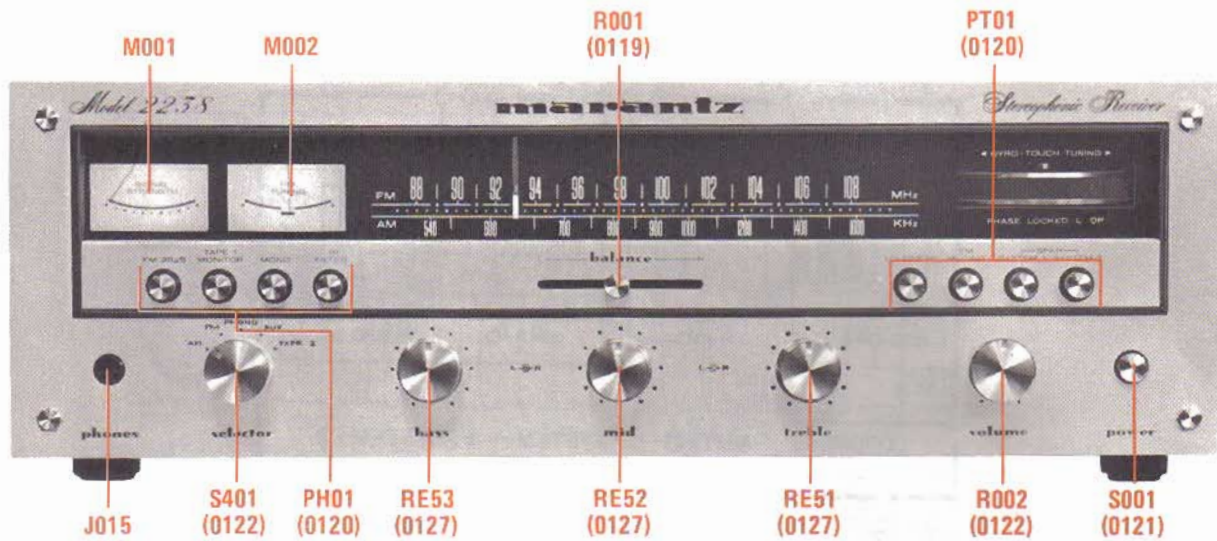

**9.2 CHASSIS - TOP VIEW**

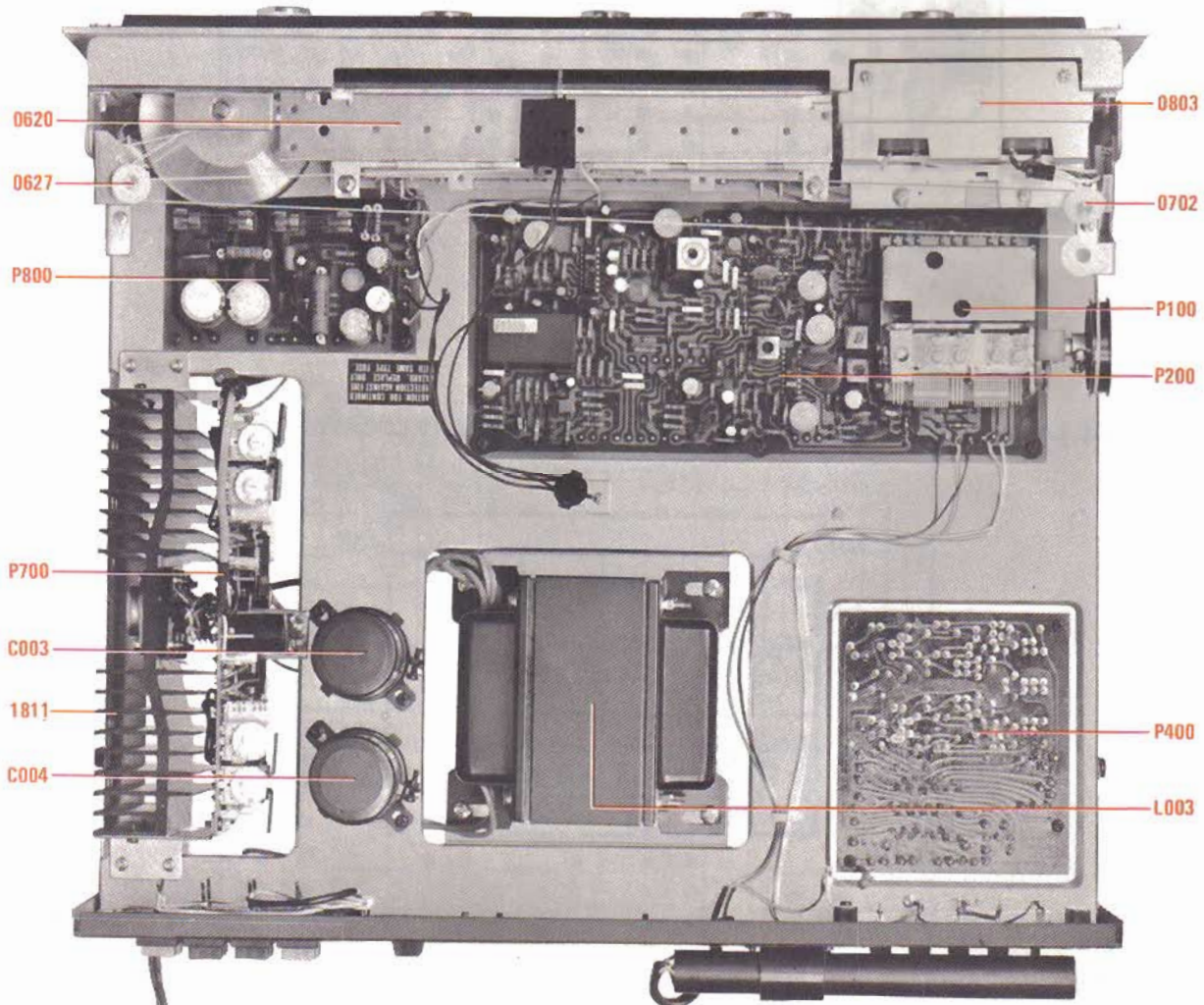



### 9.3 CABINET - REAR VIEW

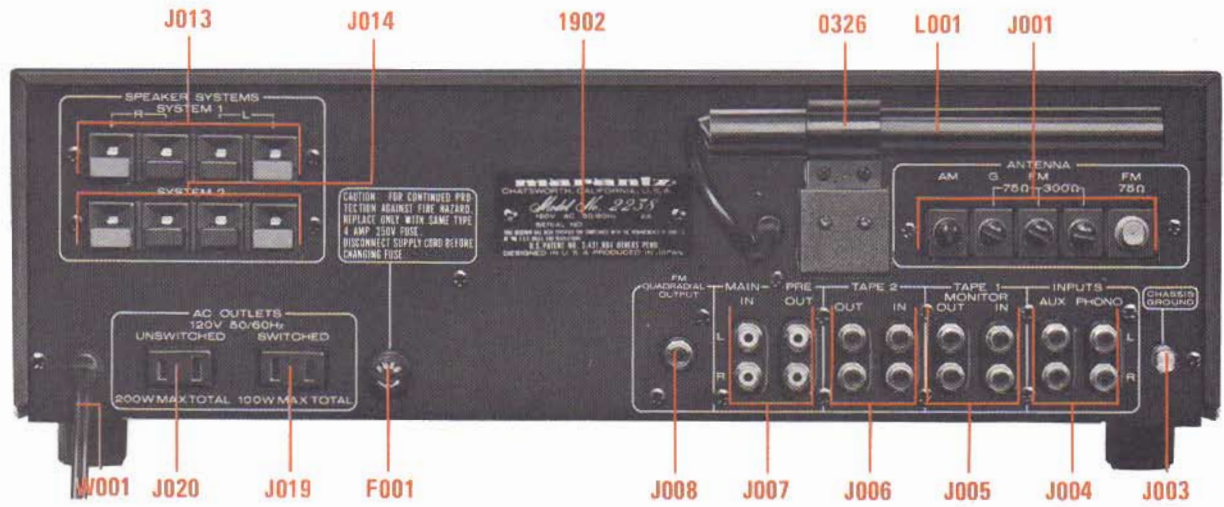

### 9.4 CHASSIS - BOTTOM VIEW

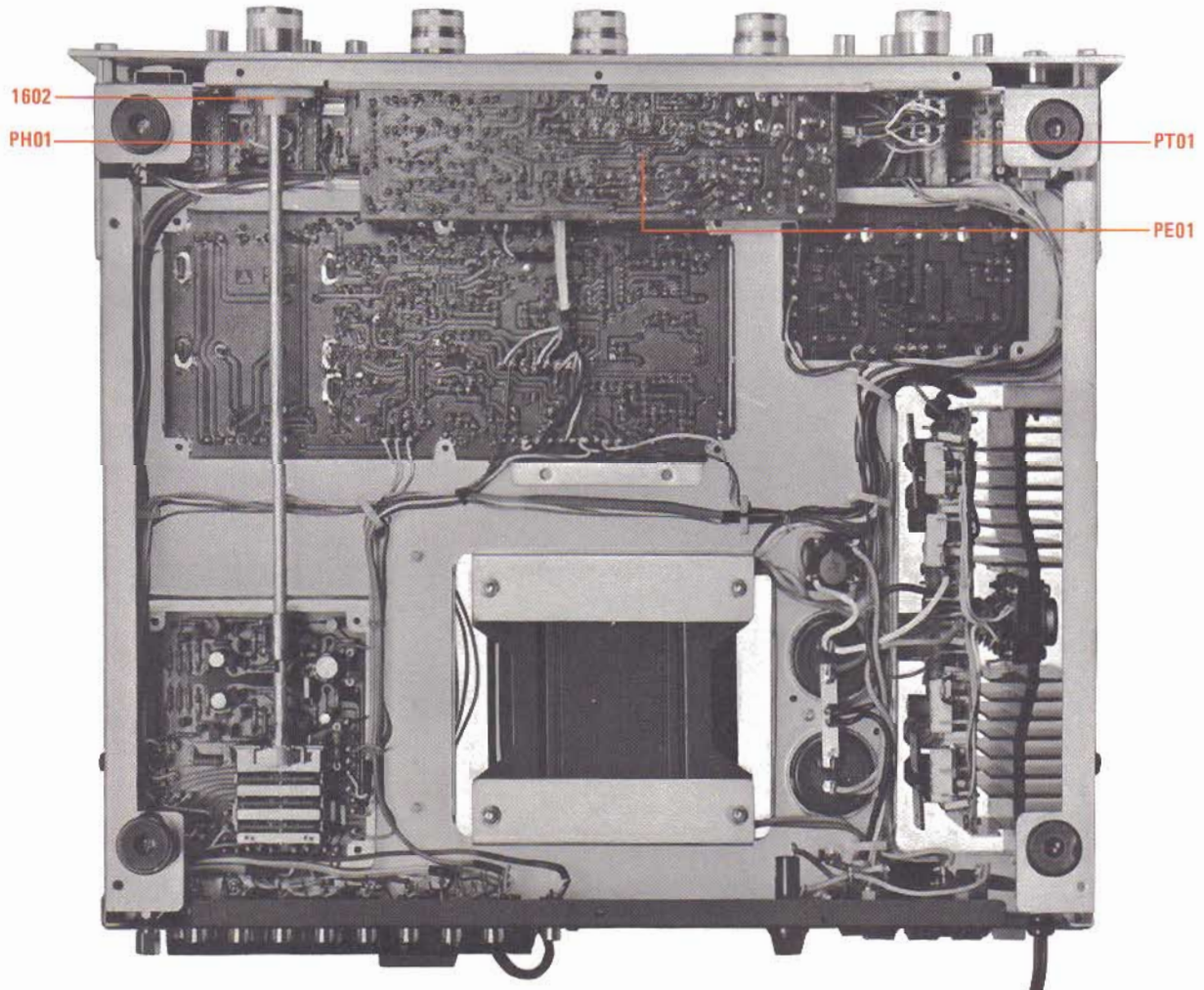



9.5 CABINET - FRONT VIEW - EUROPE

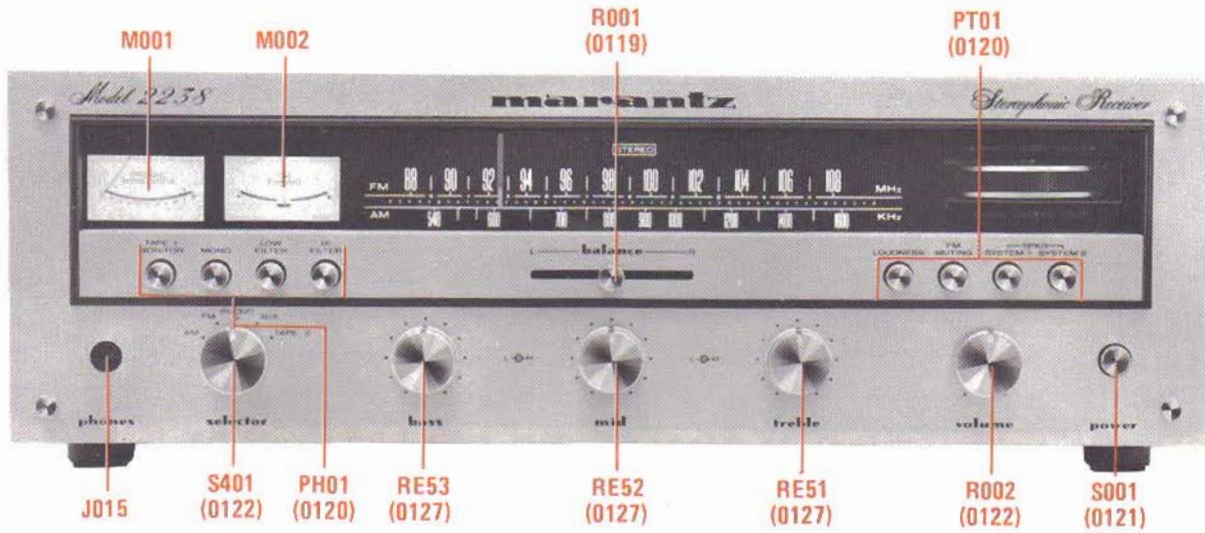

9.6 CHASSIS - TOP VIEW - EUROPE

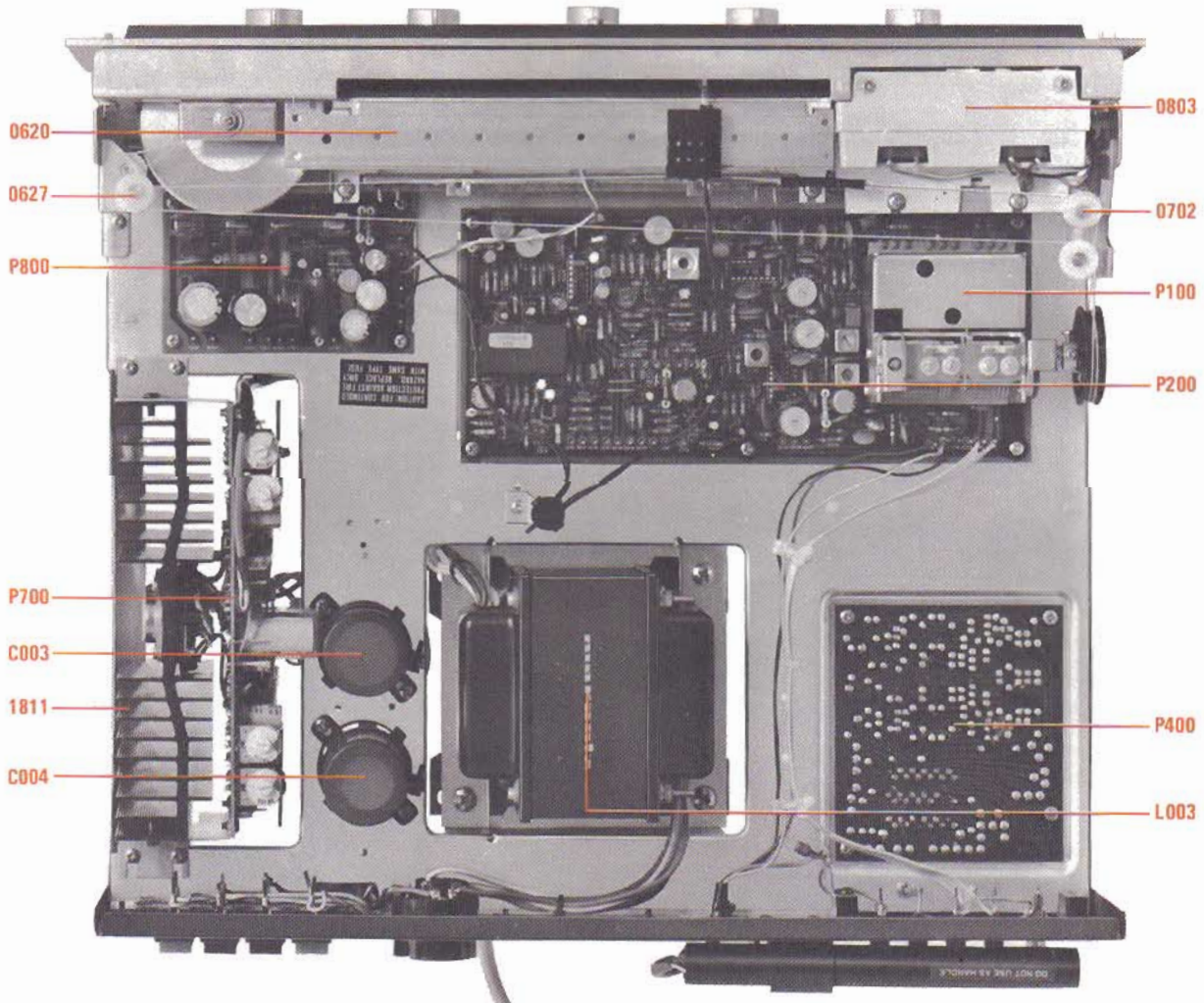

9.7 CABINET - REAR VIEW - EUROPE

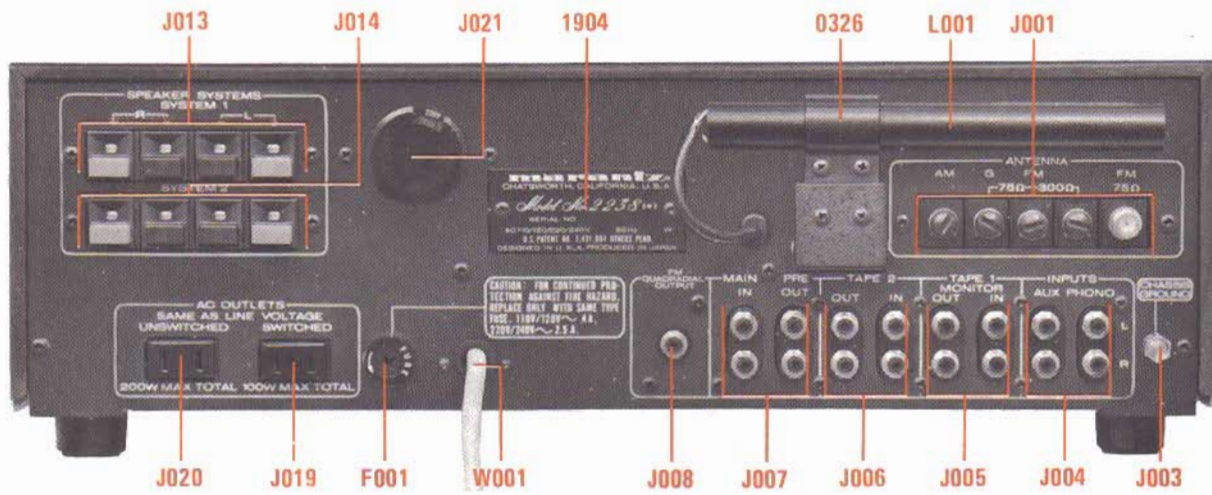



10.2 MECHANICAL EXPLODED VIEW

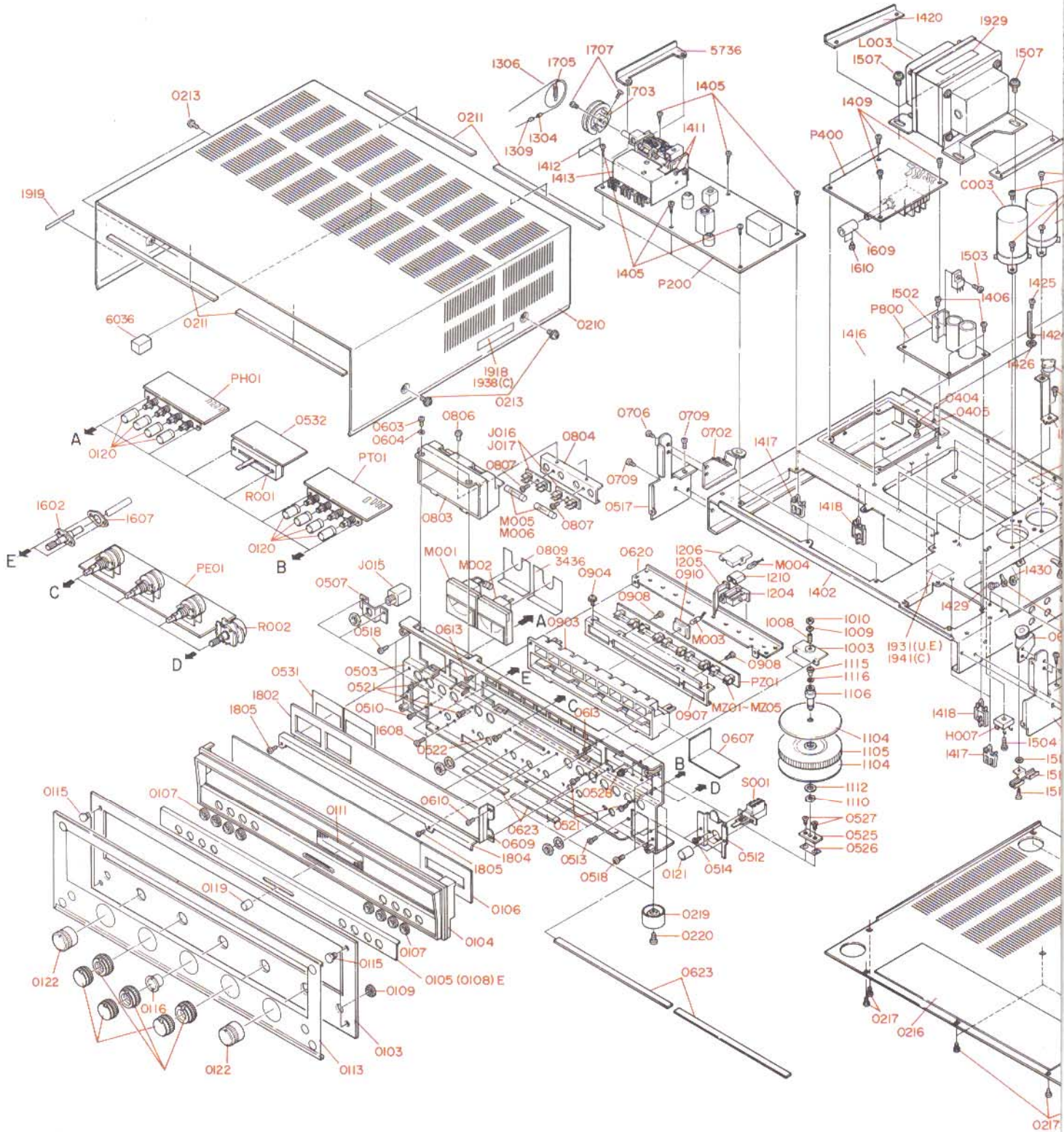







# 11. PARTS LIST

U: For U.S.A.  
C: For Canada  
E: For Europe

REF. DESIG.	Q'TY			PART NO.	DESCRIPTION
	U	C	E		
A	1	1		2206063400	Front Panel Assembly
A1			1	2206063410	Front Panel Assembly
0103	1	1	1	2206063012	Escutcheon
0104	1	1	1	2221401012	Frame
0105	1	1		2204063023	Escutcheon
0106	1	1	1	2221158010	Window
0107	8	8	8	2221259012	Bushing
0108			1	2204063032	Escutcheon
0109	1	1	1	2886259010	Bushing
0113	1	1	1	2915053010	Cover
B	1	1	1	2916257420	Lid Assembly
0210	1	1	1	2916257010	Lid
0211	4	4	4	2577118070	Spacer
6036	1	1	1	2204056010	Buffer
C	1	1	1	2204257400	Lid Assembly
0215	1	1	1	2204257010	Lid
0216	1	1	1	2915120010	Insulator
D	1	1	1	2204159400	Drum Assembly
1703	1	1	1	2204159010	Drum
1705	1	1	1	71101689L0	Spring
1707	2	2	2	51064019A9	Set Screw
E	1	1	1	2915103400	Pointer Assembly
1204	1	1	1	2915103012	Pointer
1205	1	1	1	2818103020	Pointer
1206	1	1	1	2915103020	Pointer
1210	1	1	1	2915267030	Heatsink
M004	1	1	1	IN10080300	Lamp
F	1	1	1	1202006430	Hook Assembly
1304	1	1	1	1202258010	Hook
1306	1	1	1	72071605A0	String
G	1	1	1	2853273400	Flywheel Assembly
1104	2	2	2	2577063022	Escutcheon
1105	1	1	1	2577273010	Flywheel
1106	1	1	1	2853112010	Shaft
1110	1	1	1	53110603E9	Hexagon Nut
1112	1	1	1	54020601E0	Flat Washer
H			1	2206160400	Rear Panel Assembly
0304			1	2206160210	Bracket
0316			1	2821259010	Bushing
0318			2	54050300R0	T.L. Washer
0320			2	55060305S0	T.R. Rivet
0111	1	1	1	2915107010	Sheet
0115	4	4	4	5201703950	H. Head Bolt
0116	1	1	1	2916055010	Collar
0119	1	1	1	2221154112	Knob
0120	8	8	8	2221154122	Knob
0121	1	1	1	2904154140	Knob
0122	2	2	2	2221154133	Knob
0124	3	3	3	2210154022	Knob
0127	3	3	3	2210154012	Knob
0207	2	2	2	51280306U0	B.H. Tapped Screw B
0213	4	4	4	51480406S9	B.H.M. Screw F
0217	10	10	10	51280406U0	B.H. Tapped Screw B

REF. DESIG.	Q'TY			PART NO.	DESCRIPTION
	U	C	E		
0219	4	4	4	2932057010	Leg
0220	4	4	4	51570410S0	P.H. Tapped Screw, P4x10ST
0303	1	1		2206160013	Bracket
0307	2	2	1	1455259030	Bushing
0309	4	4	4	51280308U0	B.H. Tapped Screw B, 3x8
0311	2	2	2	51280308U0	B.H. Tapped Screw B, 3x8
0312	1	1	1	51280308U0	B.H. Tapped Screw B, 3x8
0314	10	10	10	51280308U0	B.H. Tapped Screw B, 3x8
0317			2	53110303A9	Hexagon Nut
0319			2	51060316A9	P.H.M. Screw, P3x16
0322	1	1	1	62040029W0	Lug
0324	3	3	3	51100306S9	B.H.M. Screw, B3x6
0326	1	1	1	2819271130	Holder
0327	1	1	1	2578160522	Bracket K
0332	2	2	2	51280312U0	B.H. Tapped Screw B, 3x12
0334	1	1	1	62030039W0	Lug
0335	1	1	1	51280308U0	B.H. Tapped Screw B, 3x8
0401	2	2	2	51280312U0	B.H. Tapped Screw B, 3x12
0404	1	1	1	62030039W0	Lug
0405	1	1	1	51280308B0	B.H. Tapped Screw B, 3x8
0408			2	51100308S9	B.H.M. Screw, B3x8
0411	4	4	4	51280308U0	B.H. Tapped Screw B, 3x8
0412	1	1		62030049W0	Lug
0413			1	62030049W0	Lug
0414	1	1	1	51280308B0	B.H. Tapped Screw B, 3x8
0503	1	1	1	2915160505	Bracket K
0509	1	1	1	2915160060	Bracket
0510	2	2	2	51100306A9	B.H.M. Screw, B3x6
0512	1	1	1	2206160020	Bracket
0513	2	2	2	51100306A9	B.H.M. Screw, B3x6
0514	2	2	2	51060306A9	P.H.M. Screw, P3x6
0516	1	1	1	2204160020	Bracket
0517	1	1	1	2204160030	Bracket
0518	4	4	4	51100406A9	B.H.M. Screw, B4x6
0521	4	4	4	51100306A9	B.H.M. Screw, B3x6
0522	2	2	2	51100306A9	B.H.M. Screw, B3x6
0525	1	1	1	2577106020	Bearing
0526	1	1	1	1415118010	Spacer
0527	2	2	2	51040306A9	F.H.M. Screw, F3x6
0528	2	2	2	51490308A9	B.H.M. Screw FS, 3x8
0531	2	2	2	2871053020	Cover
0532	1	1	1	2915120040	Insulator
0603	2	2	2	51600306B0	P.H. Tapped Screw, P3x6ST
0607	1	1	1	2819120050	Insulator
0609	1	1	1	2853269010	Protector
0610	2	2	2	51280306B0	B.H. Tapped Screw B, 3x6
0613	2	2	2	51042608A0	F.H.M. Screw, F2.6x8
0620	1	1	1	2871051020	Guide
0623	4	4	4	2886120020	Insulator
0627	1	1	1	2915262502	Pulley K
0631	2	2	2	51100306A9	B.H.M. Screw, B3x6
0702	1	1	1	2204262502	Pulley K
0706	2	2	2	51100306A9	B.H.M. Screw, B3x6
0709	6	6	6	51280308B0	B.H. Tapped Screw B, 3x8
0803	1	1	1	2886274012	Reflector
0804	1	1	1	2886271020	Holder
0806	2	2	2	51480306A9	B.H.M. Screw F, 3x6
0807	2	2	2	51570305B0	P.H. Tapped Screw, P3x5ST
3436	1	1	1	2886107010	Sheet
0809	1	1	1	2886107010	Sheet
0903	1	1	1	2871274110	Reflector
0904	2	2	2	51480306A9	B.H.M. Screw F, 3x6
0907	1	1	1	2871271010	Holder
0908	2	2	2	51570305B0	P.H. Tapped Screw, P3x5ST



U : For U.S.A.  
C : For Canada  
E : For Europe

REF. DESIG.	Q'TY			PART NO.	DESCRIPTION
	U	C	E		
0910	1	1	1	2874259010	Bushing
1003	1	1	1	2853106500	Bearing K
1008	1	1	1	51640410D9	Set Screw C.P., 4x10
1009	1	1	1	54040402N0	Spring Washer
1010	1	1	1	53110403E9	Hexagon Nut
1115	1	1	1	2850112020	Shaft
1116	1	1	1	54040402N0	Spring Washer
1309	1	1	1	56382540G0	Eyelet
1402	1	1	1	2204105013	Chassis
1405	6	6	6	51280308U0	B.H. Tapped Screw B, 3x8
1406	4	4	4	51280306U0	B.H. Tapped Screw B, 3x6
1407	4	4	4	51280306U0	B.H. Tapped Screw B, 3x6
1411	3	3	3	51100303B9	B.H.M. Screw, B3x3
1412	1	1	1	2204109010	Shield
1413	1	1	1	2204053010	Cover
5736	1	1	1	2204005030	Clamper
1416	2	2	2	2204005040	Clamper
1417	4	4	4	2886005020	Clamper
1418	3	3	3	2886005050	Clamper
1420	2	2	2	2916160070	Bracket
1424	1	1	1	1382005030	Clamper
1425	1	1	1	51280306B0	B.H. Tapped Screw B, 3x6
1426	1	1	1	54050300R0	T.L. Washer OR
1502	1	1	1	2204267020	Heatsink
1503	1	1	1	51100306E9	B.H.M. Screw, B3x6
1504	1	1	1	51570312B0	P.H. Tapped Screw, P3x12ST
1507	4	4	4	51490514A9	B.H.M. Screw B, 5x14
1511	1	1	1	2206160030	Bracket
1512	1	1	1	51280306B0	B.H. Tapped Screw B, 3x6
1513	1	1	1	54050300R0	T.L. Washer OR
1514	4	4	4	51280306U0	B.H. Tapped Screw B, 3x6
1522	1	1	1	2927160050	Bracket
1523	1	1	1	2908259010	Bushing
1524	1	1	1	51570306B0	P.H. Tapped Screw, P3x6ST
1602	1	1	1	2204112503	Shaft K
1607	1	1	1	2204005010	Clamper
1608	2	2	2	51100310A9	B.H.M. Screw, B3x10
1609	1	1	1	2896125010	Joint
1610	2	2	2	51064019A9	Set Screw, 40x19.
1802	1	1	1	2204302012	Dial
1804	1	1	1	2915269012	Protector
1805	2	2	2	51280306B0	B.H. Tapped Screw B, 3x6
1811	1	1	1	2890267012	Heatsink
1813	1	1	1	2206104012	Retainer
1814	1	1	1	2206104022	Retainer
1815	4	4	4	51280306U0	B.H. Tapped Screw B, 3x6
1817	4	4	4	51100306S9	B.H.M. Screw, B3x6
1818	8	8	8	51100316E9	B.H.M. Screw, B3x16
1821	1	1	1	2206005012	Clamper
1823	2	2	2	2912267022	Heatsink
1824	4	4	4	51100306S9	B.H.M. Screw, B3x6
1826	2	2	2	51100205A0	B.H.M. Screw, B2x5
1827	2	2	2	59020604P0	Washer
1828	1	1	1	1210005010	Clamper
1831	4	4	4	51280306B0	B.H. Tapped Screw B, 3x6
1833	1	1	1	2819101010	Support
1834	1	1	1	51100306S9	B.H.M. Screw, B3x6
1902	1	1	1	2206265010	Indicator
1903	1	1	1	2206265020	Indicator
1904	1	1	1	2206265030	Indicator
1912	1	1	1	2506265060	Label, Do not use as handle.
1936	1	1	1	2911861170	Label, Do not use as handle.
1937	1	1	1	2911861110	Label, UL Caution
1938	1	1	1	2911861140	Label, Do not remove cover. See marking on bottom.

REF. DESIG.	Q'TY			PART NO.	DESCRIPTION
	U	C	E		
1917	1	1	1	2578861010	Label, UL Caution
1918	1	1	1	2932861010	Label, Do not remove cover. See marking on bottom.
1919	1	1	1	2818861010	Label, FTC
1921	1	1	1	9510911010	Label, LL No.
1922	1	1	1	9510911020	Label, UL Factory
1923	1	1	1	9511101020	Label, UL
1939	1	1	1	2911861010	Label
1940	1	1	1	2911861270	Label
1929	1	1	1	2886861010	Label, Marantz
1931	1	1	1	9510221010	Label, Fuse Caution
1941	2	2	2	2911861160	Label, Fuse Caution
1933	1	1	1	9510601050	Label, 5A 250V
2004	1	1	1	2577813010	Envelope, Orange
2005	1	1	1	2918813012	Envelope, Yellow
2006	1	1	1	2818813010	Envelope, Blue
2011	1	1	1	2577851020	Instructions, Important
2012	1	1	1	2818851120	Instructions, Important
2016	1	1	1	2577854012	Guarantee Card, IBM
2017	1	1	1	9630000180	Guarantee Card, IBM
2021	1	1	1	9650000050	Service Station Card
2025	1	1	1	2818854022	Guarantee Card
2026	1	1	1	2818854040	Guarantee Card
2032	1	1	1	2818851040	Instructions, Packing
2033	1	1	1	2818851140	Instructions, Packing
2104	1	1	1	2206851010	Instructions, Set
2106	1	1	1	2206851310	Instructions, Set
2109	1	1	1	2886851100	Instructions, Flysheet
2116	1	1	1	2206856010	Schematic Diagram
2202	1	1	1	2206801010	Packing Case, Inner
2203	1	1	1	2206801110	Packing Case, Outer
6436	1	1	1	2206856020	Schematic Diagram
2211	2	2	2	2204809010	Cushion
2216	1	1	1	9014838380	Polyethylene Bag, Set
2218	1	1	1	9013025010	Polyethylene Bag, Printed Matter
2219	1	1	1	9013025010	Polyethylene Bag, Accessories
2223	1	1	1	2864804010	Sleeve, AC Cord
2224	1	1	1	9560000042	Hang Tag, AC Cord
2226	1	1	1	2731821010	Silicagel
2228	1	1	1	2819056010	Buffer, AM Antenna
2231	1	1	1	2918107130	Sheet
2302	4	4	4	9522815010	Serial No. Card
2303	4	4	4	9523015120	Serial No. Card
2304	4	4	4	9523015110	Serial No. Card
2314	2	2	2	9510901020	Label
2327	1	1	1	ZA02000070	Ext. FM Antenna
P100	1	1	1	YD29910010	P.W. Board, FM Front End
A001	1	1	1	AV01202060	FM Front End Assembly
R101	1	1	1	GD05105140	Fixed, 1MΩ ±5%, ¼W
R102	1	1	1	GD05101140	Fixed, 100Ω ±5%, ¼W
R103	1	1	1	GD05101140	Fixed, 100Ω ±5%, ¼W
R104	1	1	1	GD05101140	Fixed, 100Ω ±5%, ¼W
R105	1	1	1	GD05223140	Fixed, 22kΩ ±5%, ¼W
R106	1	1	1	GD05472140	Fixed, 4.7kΩ ±5%, ¼W

**FM FRONT END CIRCUIT BOARD-P100**

P.W. Board, FM Front End  
FM Front End Assembly

**P100-RESISTORS**

Fixed, 1MΩ ±5%, ¼W  
Fixed, 100Ω ±5%, ¼W  
Fixed, 100Ω ±5%, ¼W  
Fixed, 100Ω ±5%, ¼W  
Fixed, 22kΩ ±5%, ¼W  
Fixed, 4.7kΩ ±5%, ¼W



U : For U.S.A.  
C : For Canada  
E : For Europe

REF. DESIG.	Q'TY			PART NO.	DESCRIPTION
	U	C	E		
R107	1	1	1	GD05102140	Fixed, 1kΩ ±5%, ¼W
R108	1	1	1	GD05103140	Fixed, 10kΩ ±5%, ¼W
R109	1	1	1	GD05333140	Fixed, 33kΩ ±5%, ¼W
R110	1	1	1	GD05103140	Fixed, 10kΩ ±5%, ¼W
R111	1	1	1	GD05101140	Fixed, 100Ω ±5%, ¼W
<b>P100-CAPACITORS</b>					
C101	1	1	1	DD16120020	Ceramic, 12pF ±10%
C102	1	1	1	DK18203030	Ceramic, 0.02μF +80%, -20%
C103	1	1	1	DK18203030	Ceramic, 0.02μF +80%, -20%
C104	1	1	1	DD11020010	Ceramic, 2pF ±0.5pF
C105	1	1	1	DK18203030	Ceramic, 0.02μF +80%, -20%
C106	1	1	1	DD16150040	Ceramic, 15pF ±10%
C107	1	1	1	DD11020010	Ceramic, 2pF ±0.5pF
C108	1	1	1	DD12050010	Ceramic, 5pF ±1pF
C109	1	1	1	DD16101010	Ceramic, 100pF ±10%
C110	1	1	1	DK18203030	Ceramic, 0.02μF +80%, -20%
C111	1	1	1	DD16101010	Ceramic, 100pF ±10%
C112	1	1	1	DK18203030	Ceramic, 0.02μF +80%, -20%
C113	1	1	1	DD15150020	Ceramic, 15pF ±5%
C114	1	1	1	DD10050030	Ceramic, 5pF ±0.25pF
C115	1	1	1	DD12050010	Ceramic, 5pF ±1pF
C116	1	1	1	DD16330020	Ceramic, 33pF ±10%
C117	1	1	1	DD12100060	Ceramic, 10pF ±1pF
C118	1	1	1	DK18203030	Ceramic, 0.02μF +80%, -20%
C119	1	1	1	DD11020010	Ceramic, 2pF ±0.5pF
C120	1	1	1	CA32400080	Variable
C121	1	1	1	CT14200010	Trimming, Oscillator
<b>P100-MISCELLANEOUS</b>					
L101	1	1	1	LL24700050	Antenna Coil, FM (Primary)
L102	1	1	1	LK12700040	Antenna Coil, FM (Secondary)
L103	1	1	1	LL22700020	RF Coil, FM (Primary)
L104	1	1	1	LK11700040	RF Coil, FM (Secondary)
L105	1	1	1	LC12220010	Choke Coil, 2.2μH
L106	1	1	1	LI10239010	IFT, FM
L107	1	1	1	LK12500040	OSC Coil
Q101	1	1	1	HF400451B0	FET, 3SK45B
Q102	1	1	1	HT305352B0	Transistor, 2SC535
Q103	1	1	1	HT313422B0	Transistor, 2SC1342
J101	1	1	1	YP10001510	Plug
J102	1	1	1	YP10001510	Plug
J103	1	1	1	YP10001510	Plug
J105	1	1	1	YP10001510	Plug
J107	1	1	1	YP10001510	Plug
J109	1	1	1	YP10001510	Plug
J110	1	1	1	YP10001510	Plug
<b>TUNER CIRCUIT BOARD- P200</b>					
P200	1	1	1	YD22042010	P.W. Board, Tuner
	1	1	1	ZZ22062010	P.W. Board Assembly
			1	ZZ22068010	P.W. Board Assembly
<b>P200-RESISTORS</b>					
R151	1	1	1	RT05201141	Fixed, 200Ω ±5%, ¼W
R152	1	1	1	RT05152141	Fixed, 1.5kΩ ±5%, ¼W
R153	1	1	1	RT05202141	Fixed, 2kΩ ±5%, ¼W
R154	1	1	1	RT05152141	Fixed, 1.5kΩ ±5%, ¼W
R155	1	1	1	RT05151140	Fixed, 150Ω ±5%, ¼W
R156	1	1	1	RA05020200	Trimming, 5kΩ (B)
R157	1	1	1	RT05471141	Fixed, 470Ω ±5%, ¼W
R158	1	1	1	RT05124141	Fixed, 120kΩ ±5%, ¼W

REF. DESIG.	Q'TY			PART NO.	DESCRIPTION
	U	C	E		
R159	1	1	1	RT05104141	Fixed, 100kΩ ±5%, ¼W
R160	1	1	1	RT05103141	Fixed, 10kΩ ±5%, ¼W
R161	1	1	1	RT05103141	Fixed, 10kΩ ±5%, ¼W
R162	1	1	1	RT05102141	Fixed, 1kΩ ±5%, ¼W
R163	1	1	1	RT05301141	Fixed, 300Ω ±5%, ¼W
R164	1	1	1	RT05473141	Fixed, 47kΩ ±5%, ¼W
R165	1	1	1	RT05104141	Fixed, 100kΩ ±5%, ¼W
R166	1	1	1	RT05152141	Fixed, 1.5kΩ ±5%, ¼W
R167	1	1	1	RT05242141	Fixed, 2.4kΩ ±5%, ¼W
R169	1	1	1	RT05473141	Fixed, 47kΩ ±5%, ¼W
R170	1	1	1	RT05101140	Fixed, 100Ω ±5%, ¼W
R201	1	1	1	RT05151141	Fixed, 150Ω ±5%, ¼W
R202	1	1	1	RT05331141	Fixed, 330Ω ±5%, ¼W
R203	1	1	1	RT05153141	Fixed, 15kΩ ±5%, ¼W
R204	1	1	1	RT05272141	Fixed, 2.7kΩ ±5%, ¼W
R205	1	1	1	RT05331141	Fixed, 330Ω ±5%, ¼W
R206	1	1	1	RT05102141	Fixed, 1kΩ ±5%, ¼W
R207	1	1	1	RT05101141	Fixed, 100Ω ±5%, ¼W
R208	1	1	1	RT05334141	Fixed, 330kΩ ±5%, ¼W
R209	1	1	1	RA05030120	Trimming, 50kΩ (B)
R210	1	1	1	RT05103141	Fixed, 10kΩ ±5%, ¼W
R211	1	1	1	RT05104141	Fixed, 100kΩ ±5%, ¼W
R212	1	1	1	RA01030250	Trimming, 10kΩ (B)
R213	1	1	1	RT05123141	Fixed, 12kΩ ±5%, ¼W
R214	1	1	1	RT05331141	Fixed, 330Ω ±5%, ¼W
R215	1	1	1	RA05030120	Trimming, 50kΩ (B)
R216	1	1	1	RT05562141	Fixed, 5.6kΩ ±5%, ¼W
R217	1	1	1	RT05222141	Fixed, 2.2kΩ ±5%, ¼W
R218	1	1	1	RT05222141	Fixed, 2.2kΩ ±5%, ¼W
R219	1	1	1	RT05153141	Fixed, 15kΩ ±5%, ¼W
R220	1	1	1	RT05102141	Fixed, 1kΩ ±5%, ¼W
R221	1	1	1	RT05223141	Fixed, 22kΩ ±5%, ¼W
R222	1	1	1	RT05473141	Fixed, 47kΩ ±5%, ¼W
R301	1	1	1	RA01030310	Trimming, 10kΩ (B)
R302	1	1	1	RT05104141	Fixed, 100kΩ ±5%, ¼W
R303	1	1	1	RT05223141	Fixed, 22kΩ ±5%, ¼W
R304	1	1	1	RT05102141	Fixed, 1kΩ ±5%, ¼W
R305	1	1	1	RT05104141	Fixed, 100kΩ ±5%, ¼W
R306	1	1	1	RT05824141	Fixed, 820kΩ ±5%, ¼W
R307	1	1	1	RT05473141	Fixed, 47kΩ ±5%, ¼W
R308	1	1	1	RC00000120	Fixed, 0Ω, ¼W
R309	1	1	1	RT05224141	Fixed, 220kΩ ±5%, ¼W
R310	1	1	1	RT05223141	Fixed, 22kΩ ±5%, ¼W
R311	1	1	1	RT05272141	Fixed, 2.7kΩ ±5%, ¼W
R312	1	1	1	RT05101140	Fixed, 100Ω ±5%, ¼W
R313	1	1	1	RT05303141	Fixed, 30kΩ ±5%, ¼W
R314	1	1	1	RT05303141	Fixed, 30kΩ ±5%, ¼W
R315	1	1	1	RT05473141	Fixed, 47kΩ ±5%, ¼W
R316	1	1	1	RT05473141	Fixed, 47kΩ ±5%, ¼W
R317	1	1	1	RA02540010	Trimming, 250kΩ (B)
R318	1	1	1	RT05104141	Fixed, 100kΩ ±5%, ¼W
R319	1	1	1	RT05273141	Fixed, 27kΩ ±5%, ¼W
R320	1	1	1	RT05273141	Fixed, 27kΩ ±5%, ¼W
R321	1	1	1	RT05332141	Fixed, 3.3kΩ ±5%, ¼W
R322	1	1	1	RT05332141	Fixed, 3.3kΩ ±5%, ¼W
R323	1	1	1	RT05332141	Fixed, 3.3kΩ ±5%, ¼W
R324	1	1	1	RT05332141	Fixed, 3.3kΩ ±5%, ¼W
R325	1	1	1	RT05243141	Fixed, 24kΩ ±5%, ¼W
R326	1	1	1	RT05243141	Fixed, 24kΩ ±5%, ¼W
R327	1	1	1	RT05394140	Fixed, 390kΩ ±5%, ¼W
R328	1	1	1	RT05394141	Fixed, 390kΩ ±5%, ¼W
R329	1	1	1	RT05105141	Fixed, 1MΩ ±5%, ¼W



U: For U.S.A.  
C: For Canada  
E: For Europe

REF. DESIG.	Q'TY			PART NO.	DESCRIPTION
	U	C	E		
R330	1	1	1	RT05105141	Fixed, 1MΩ ±5%, ¼W
R331	1	1	1	RT05391140	Fixed, 390Ω ±5%, ¼W
R332	1	1	1	RT05391141	Fixed, 390Ω ±5%, ¼W
R333	1	1	1	RT05222141	Fixed, 2.2kΩ ±5%, ¼W
R334	1	1	1	RT05222141	Fixed, 2.2kΩ ±5%, ¼W
R335	1	1	1	RT05473141	Fixed, 47kΩ ±5%, ¼W
R336	1	1	1	RT05473141	Fixed, 47kΩ ±5%, ¼W
R337	1	1	1	RT05101141	Fixed, 100Ω ±5%, ¼W
R338	1	1	1	RT05101141	Fixed, 100Ω ±5%, ¼W
R339	1	1	1	RT05101140	Fixed, 100Ω ±5%, ¼W
R340	1	1	1	RT05201141	Fixed, 200Ω ±5%, ¼W
<b>P100-CAPACITORS</b>					
C151	1	1	1	DK17103040	Ceramic, 0.01μF ±20%
C152	1	1	1	DK17103040	Ceramic, 0.01μF ±20%
C153	1	1	1	DK17102010	Ceramic, 0.001μF ±20%
C154	1	1	1	EA10701690	Electrolytic, 100μF, 16V
C155	1	1	1	DK18403020	Ceramic, 0.04μF +80%, -20%
C156	1	1	1	DF65391010	Film, 390pF ±5%
C157	1	1	1	DD16150070	Ceramic, 15pF ±10%
C158	1	1	1	DK17103040	Ceramic, 0.01μF ±20%
C159	1	1	1	DK17103010	Ceramic, 0.01μF ±20%
C160	1	1	1	DD15820010	Ceramic, 82pF ±5%
C161	1	1	1	DK17103040	Ceramic, 0.01μF ±20%
C162	1	1	1	DK18403020	Ceramic, 0.04μF +80%, -20%
C163	1	1	1	EA10505090	Electrolytic, 1μF, 50V
C164	1	1	1	EA47503590	Electrolytic, 4.7μF, 35V
C165	1	1	1	EA33502590	Electrolytic, 3.3μF, 25V
C166	1	1	1	DK17102010	Ceramic, 0.001μF ±20%
C167	1	1	1	DK17103040	Ceramic, 0.01μF ±20%
C168	1	1	1	DK17502010	Ceramic, 0.005μF ±20%
C169	1	1	1	DK18403020	Ceramic, 0.04μF +80%, -20%
C170	1	1	1	EA10701690	Electrolytic, 100μF, 16V
C171	1	1	1	DF16104010	Film, 0.1μF, 50V
C172	1	1	1	EV47501660	Electrolytic, 4.7μF, 16V
C201	1	1	1	DD15300010	Ceramic, 30pF ±5%
C202	1	1	1	DK17103040	Ceramic, 0.01μF ±20%
C203	1	1	1	DK17103040	Ceramic, 0.01μF ±20%
C204	1	1	1	DK17103040	Ceramic, 0.01μF ±20%
C205	1	1	1	DK18403020	Ceramic, 0.04μF +80%, -20%
C206	1	1	1	DK18403020	Ceramic, 0.04μF +80%, -20%
C207	1	1	1	DK18403020	Ceramic, 0.04μF +80%, -20%
C208	1	1	1	EA47503590	Electrolytic, 4.7μF, 35V
C209	1	1	1	DD15400040	Ceramic, 40pF ±5%
C210	1	1	1	EA22601690	Electrolytic, 22μF, 16V
C211	1	1	1	EA47405010	Electrolytic, 0.47μF, 50V
C212	1	1	1	DK18403010	Ceramic, 0.04μF +100%, -0%
C213	1	1	1	DK18403010	Ceramic, 0.04μF +100%, -0%
C214	1	1	1	DK18203020	Ceramic, 0.02μF +100%, -0%
C215	1	1	1	DK18203020	Ceramic, 0.02μF +100%, -0%
C216	1	1	1	DK18403010	Ceramic, 0.04μF +100%, -0%
C217	1	1	1	EA10505090	Electrolytic, 1μF, 50V
C218	1	1	1	EA10505090	Electrolytic, 1μF, 50V
C301	1	1	1	EA47503590	Electrolytic, 4.7μF, 35V
C302	1	1	1	DF65361500	Film, 360pF ±5%
C303	1	1	1	EA10701690	Electrolytic, 100μF, 16V
C304	1	1	1	EE33502510	Electrolytic, 3.3μF, 25V
C305	1	1	1	EE10505010	Electrolytic, 1μF, 50V
C306	1	1	1	EA10505090	Electrolytic, 1μF, 50V
C307	1	1	1	EQ22405010	Electrolytic, 0.22μF, 50V
C308	1	1	1	DF17473010	Film, 0.047μF
C309	1	1	1	DD15500050	Ceramic, 50pF ±5%
C310	1	1	1	DD15500050	Ceramic, 50pF ±5%

REF. DESIG.	Q'TY			PART NO.	DESCRIPTION
	U	C	E		
C311	1	1	1	EA10601690	Electrolytic, 10μF, 16V
C312	1	1	1	EA10601690	Electrolytic, 10μF, 16V
C313	1	1	1	EA22505090	Electrolytic, 2.2μF, 50V
C314	1	1	1	EA22505090	Electrolytic, 2.2μF, 50V
C315	1	1	1	DF15102050	Film, 1000pF ±5%
C316	1	1	1	DF15102050	Film, 1000pF ±5%
C315	1	1	1	DF15222050	Film, 0.0022μF ±5%
C316	1	1	1	DF15222050	Film, 0.0022μF ±5%
C317	1	1	1	EA47405010	Electrolytic, 0.47μF, 50V
C318	1	1	1	EA47405010	Electrolytic, 0.47μF, 50V
C319	1	1	1	EV47501660	Electrolytic, 4.7μF, 16V
C320	1	1	1	EV47501660	Electrolytic, 4.7μF, 16V
C321	1	1	1	EA10701690	Electrolytic, 100μF, 16V
C322	1	1	1	EE10601620	Electrolytic, 10μF, 16V
<b>P200-COILS, TRANSFORMERS &amp; FILTER</b>					
L151	1	1	1	LC13320020	Choke Coil, 3.3μH
L152	1	1	1	LC13320020	Choke Coil, 3.3μH
L153	1	1	1	LC13320020	Choke Coil, 3.3μH
L154	1	1	1	LO10010480	AM OSC
L155	1	1	1	LI10015010	AM IFT
L156	1	1	1	LI10015060	AM IFT
L201	1	1	1	LC13320020	Choke Coil, 3.3μH
L202	1	1	1	LI14019010	FM IFT
L203	1	1	1	LC11830010	Choke Coil, 18μH
L301	1	1	1	LS35025010	Low Pass Filter, FB3605
<b>P200-SEMICONDUCTORS</b>					
Q151	1	1	1	HC10019010	IC, HA1197
Q152	1	1	1	HT313272A0	Transistor, 2SC1327 S or T
Q201	1	1	1	HT310471C0	Transistor, 2SC1047 C
Q202	1	1	1	HC10021010	IC, HA1137 W
Q203	1	1	1	HD20011050	Diode, 1S1555
Q204	1	1	1	HD20011050	Diode, 1S1555
Q205	1	1	1	HD20011050	Diode, 1S1555
Q206	1	1	1	HT308281D0	Transistor, 2SC828 S
Q207	1	1	1	HD20011050	Diode, 1S1555
Q301	1	1	1	HT308281D0	Transistor, 2SC828 S
Q302	1	1	1	HC10020010	IC, HA1196
Q303	1	1	1	HT313441E0	Transistor, 2SC1344E
Q304	1	1	1	HT313441E0	Transistor, 2SC1344E
<b>P200-MISCELLANEOUS</b>					
P208	8	8	8	2933118020	Spacer, R155, R170, R312, R339
F151	1	1	1	FF10045160	Ceramic Filter, AM
F201	1	1	1	FF11070050	Ceramic Filter, FM
F202	1	1	1	FF11070050	Ceramic Filter, FM
F203	1	1	1	FF11070050	Ceramic Filter, FM
J201	1	1	1	YP10001130	Plug
J232	32	32	32		
<b>EQUALIZER AMP. CIRCUIT BOARD-P400</b>					
P400	1	1	1	YA22040210	P.W. Board, Equalizer Amp.
	1	1	1	ZZ22040210	P.W. Board Assembly
<b>P400-RESISTORS</b>					
R401	1	1	1	RT05913141	Fixed, 91kΩ ±5%, ¼W
R402	1	1	1	RT05913141	Fixed, 91kΩ ±5%, ¼W
R403	1	1	1	RT05471141	Fixed, 470Ω ±5%, ¼W



U: For U.S.A.  
C: For Canada  
E: For Europe

REF. DESIG.	Q'TY			PART NO.	DESCRIPTION
	U	C	E		
R404	1	1	1	RT05471141	Fixed, 470Ω ±5%, ¼W
R405	1	1	1	RN05394140	Fixed, 390kΩ ±5%, ¼W
R406	1	1	1	RN05394140	Fixed, 390kΩ ±5%, ¼W
R407	1	1	1	RT05223141	Fixed, 22kΩ ±5%, ¼W
R408	1	1	1	RT05223141	Fixed, 22kΩ ±5%, ¼W
R409	1	1	1	RT05681141	Fixed, 680Ω ±5%, ¼W
R410	1	1	1	RT05681141	Fixed, 680Ω ±5%, ¼W
R411	1	1	1	RN05104140	Fixed, 100kΩ ±5%, ¼W
R412	1	1	1	RN05104140	Fixed, 100kΩ ±5%, ¼W
R413	1	1	1	RT05303141	Fixed, 30kΩ ±5%, ¼W
R414	1	1	1	RT05303141	Fixed, 30kΩ ±5%, ¼W
R415	1	1	1	RT05562141	Fixed, 5.6kΩ ±5%, ¼W
R416	1	1	1	RT05562141	Fixed, 5.6kΩ ±5%, ¼W
R417	1	1	1	RT05182141	Fixed, 1.8kΩ ±5%, ¼W
R418	1	1	1	RT05182141	Fixed, 1.8kΩ ±5%, ¼W
R419	1	1	1	RT05472141	Fixed, 4.7kΩ ±5%, ¼W
R420	1	1	1	RT05472141	Fixed, 4.7kΩ ±5%, ¼W
R421	1	1	1	RT05224141	Fixed, 220kΩ ±5%, ¼W
R422	1	1	1	RT05224141	Fixed, 220kΩ ±5%, ¼W
R423	1	1	1	RT05473141	Fixed, 47kΩ ±5%, ¼W
R424	1	1	1	RT05473141	Fixed, 47kΩ ±5%, ¼W
R425	1	1	1	RT05152141	Fixed, 1.5kΩ ±5%, ¼W
R426	1	1	1	RT05152141	Fixed, 1.5kΩ ±5%, ¼W
R427	1	1	1	RN05564140	Fixed, 560kΩ ±5%, ¼W
R428	1	1	1	RN05564140	Fixed, 560kΩ ±5%, ¼W
R429	1	1	1	RT05101140	Fixed, 100Ω ±5%, ¼W
R430	1	1	1	GJ05681010	Fixed, 680Ω ±5%, 1W
R431	1	1	1	GF05330120	Fixed, 33Ω ±5%, ¼W
R400	1	1	1	RC00000120	Fixed, 0Ω, ¼W
<b>P400-CAPACITORS</b>					
C401	1	1	1	EV22502560	Electrolytic, 2.2μF ±20%, 25V
C402	1	1	1	EV22502560	Electrolytic, 2.2μF ±20%, 25V
C403	1	1	1	DD15201010	Ceramic, 200pF ±10%, 50V
C404	1	1	1	DD15201010	Ceramic, 200pF ±10%, 50V
C405	1	1	1	DD16151010	Ceramic, 150pF ±10%, 50V
C406	1	1	1	DD16151010	Ceramic, 150pF ±10%, 50V
C407	1	1	1	EV22600660	Electrolytic, 22μF ±20%, 6.3V
C408	1	1	1	EV22600660	Electrolytic, 22μF ±20%, 6.3V
C409	1	1	1	DD16300010	Ceramic, 30pF ±10%, 50V
C410	1	1	1	DD16300010	Ceramic, 30pF ±10%, 50V
C411	1	1	1	EA47601690	Electrolytic, 47μF +100%, -10%, 16V
C412	1	1	1	EA47601690	Electrolytic, 47μF +100%, -10%, 16V
C413	1	1	1	DD16101010	Ceramic, 100pF ±10%, 50V
C414	1	1	1	DD16101010	Ceramic, 100pF ±10%, 50V
C415	1	1	1	EE22503510	Electrolytic, 2.2μF ±20%, 35V
C416	1	1	1	EE22503510	Electrolytic, 2.2μF ±20%, 35V
C417	1	1	1	DF15152010	Film, 0.0015μF ±20%, 50V
C418	1	1	1	DF15152010	Film, 0.0015μF ±20%, 50V
C419	1	1	1	DF15562010	Film, 0.0056μF ±50%, 50V
C420	1	1	1	DF15562010	Film, 0.0056μF ±50%, 50V
C421	1	1	1	EA10705090	Electrolytic, 100μF +100%, -10%, 50V
C422	1	1	1	EA47601090	Electrolytic, 47μF +100%, -10%, 10V
<b>P400-MISCELLANEOUS</b>					
Q401	1	1	1	HT313281T0	Transistor, 2SC1328 T
Q402	1	1	1	HT313281T0	Transistor, 2SC1328 T
Q403	1	1	1	HT313282A0	Transistor, 2SC1328 S or T
Q404	1	1	1	HT313282A0	Transistor, 2SC1328 S or T
Q405	1	1	1	HT313281T0	Transistor, 2SC1328 T

REF. DESIG.	Q'TY			PART NO.	DESCRIPTION
	U	C	E		
Q406	1	1	1	HT313281T0	Transistor, 2SC1328 T
S401	1	1	1	SR10050120	Rotary Switch, Selector
P408	6	6	6	2933118020	Spacer, R429~R431 (10mm)
J401	?				
J435	35	35	35	YP10001131	Plug
<b>MAIN AMP. CIRCUIT BOARD-P700</b>					
P700	1	1	1	YD29581013	P.W. Board, Main Amp.
	1	1	1	ZZ22061012	P.W. Board Assembly
<b>P700-RESISTORS</b>					
R701	1	1	1	RT05102140	Fixed, 1.0kΩ ±5%, ¼W
R702	1	1	1	RT05102140	Fixed, 1.0kΩ ±5%, ¼W
R703	1	1	1	RT05333140	Fixed, 33kΩ ±5%, ¼W
R704	1	1	1	RT05333140	Fixed, 33kΩ ±5%, ¼W
R705	1	1	1	RT05682140	Fixed, 6.8kΩ ±5%, ¼W
R706	1	1	1	RT05682140	Fixed, 6.8kΩ ±5%, ¼W
R707	1	1	1	RT05102140	Fixed, 1kΩ ±5%, ¼W
R708	1	1	1	RT05102140	Fixed, 1kΩ ±5%, ¼W
R709	1	1	1	RT05103140	Fixed, 10kΩ ±5%, ¼W
R710	1	1	1	RT05103140	Fixed, 10kΩ ±5%, ¼W
R711	1	1	1	RA05020170	Trimming, 5kΩ (B)
R712	1	1	1	RA05020170	Trimming, 5kΩ (B)
R713	1	1	1	RT05472140	Fixed, 4.7kΩ ±5%, ¼W
R714	1	1	1	RT05472140	Fixed, 4.7kΩ ±5%, ¼W
R715	1	1	1	RT05154140	Fixed, 150kΩ ±5%, ¼W
R716	1	1	1	RT05154140	Fixed, 150kΩ ±5%, ¼W
R717	1	1	1	RT05302140	Fixed, 3.0kΩ ±5%, ¼W
R718	1	1	1	RT05302140	Fixed, 3.0kΩ ±5%, ¼W
R719	1	1	1	RT05333140	Fixed, 33kΩ ±5%, ¼W
R720	1	1	1	RT05333140	Fixed, 33kΩ ±5%, ¼W
R721	1	1	1	GF05330140	Fixed, 33Ω ±5%, ¼W
R722	1	1	1	GF05330140	Fixed, 33Ω ±5%, ¼W
R723	1	1	1	GF05221140	Fixed, 220Ω ±5%, ¼W
R724	1	1	1	GF05221140	Fixed, 220Ω ±5%, ¼W
R725	1	1	1	RT05242140	Fixed, 2.4kΩ ±5%, ¼W
R726	1	1	1	RT05242140	Fixed, 2.4kΩ ±5%, ¼W
R727	1	1	1	RT05472140	Fixed, 4.7kΩ ±5%, ¼W
R728	1	1	1	RT05472140	Fixed, 4.7kΩ ±5%, ¼W
R729	1	1	1	RT05750140	Fixed, 75Ω ±5%, ¼W
R730	1	1	1	RT05750140	Fixed, 75Ω ±5%, ¼W
R731	1	1	1	HH00003030	Thermistor, STD-04
R732	1	1	1	HH00003030	Thermistor, STD-04
R733	1	1	1	RA03010020	Trimming, 300Ω (B)
R734	1	1	1	RA03010020	Trimming, 300Ω (B)
R735	1	1	1	RT05221140	Fixed, 220Ω ±5%, ¼W
R736	1	1	1	RT05221140	Fixed, 220Ω ±5%, ¼W
R737	1	1	1	GF05242140	Fixed, 2.4kΩ ±5%, ¼W
R738	1	1	1	GF05242140	Fixed, 2.4kΩ ±5%, ¼W
R739	1	1	1	GF05332140	Fixed, 3.3kΩ ±5%, ¼W
R740	1	1	1	GF05332140	Fixed, 3.3kΩ ±5%, ¼W
R741	1	1	1	GF05182140	Fixed, 1.8kΩ ±5%, ¼W
R742	1	1	1	GF05182140	Fixed, 1.8kΩ ±5%, ¼W
R743	1	1	1	GF05432140	Fixed, 4.3kΩ ±5%, ¼W
R744	1	1	1	GF05432140	Fixed, 4.3kΩ ±5%, ¼W
R745	1	1	1	GF05182140	Fixed, 1.8kΩ ±5%, ¼W
R746	1	1	1	GF05182140	Fixed, 1.8kΩ ±5%, ¼W
R747	1	1	1	GF05101140	Fixed, 100Ω ±5%, ¼W



U: For U.S.A.  
C: For Canada  
E: For Europe

REF. DESIG.	Q'TY			PART NO.	DESCRIPTION
	U	C	E		
R748	1	1	1	GF05101140	Fixed, 100Ω ±5%, ¼W
R749	1	1	1	GF05101140	Fixed, 100Ω ±5%, ¼W
R750	1	1	1	GF05101140	Fixed, 100Ω ±5%, ¼W
R751	1	1	1	GF05100140	Fixed, 10Ω ±5%, ¼W
R752	1	1	1	GF05100140	Fixed, 10Ω ±5%, ¼W
R753	1	1	1	GF05221120	Fixed, 220Ω ±5%, ½W
R754	1	1	1	GF05221120	Fixed, 220Ω ±5%, ½W
R755	1	1	1	GF05221120	Fixed, 220Ω ±5%, ½W
R756	1	1	1	GF05221120	Fixed, 220Ω ±5%, ½W
R757	1	1	1	GF05100140	Fixed, 10Ω ±5%, ¼W
R758	1	1	1	GF05100140	Fixed, 10Ω ±5%, ¼W
R759	1	1	1	GW10332030	Fixed, 0.33Ω ±10%, 3W
R760	1	1	1	GW10332030	Fixed, 0.33Ω ±10%, 3W
R761	1	1	1	GW10332030	Fixed, 0.33Ω ±10%, 3W
R762	1	1	1	GW10332030	Fixed, 0.33Ω ±10%, 3W
R763	1	1	1	GJ05100020	Fixed, 10Ω ±5%, 2W
R764	1	1	1	GJ05100020	Fixed, 10Ω ±5%, 2W
R765	1	1	1	GF05220140	Fixed, 22Ω ±5%, ¼W
R766	1	1	1	GF05102120	Fixed, 1kΩ ±5%, ½W
R767	1	1	1	RC10562120	Fixed, 5.6kΩ ±10%, ½W
R768	1	1	1	RC10562120	Fixed, 5.6kΩ ±10%, ½W
R769	1	1	1	RT05223140	Fixed, 22kΩ ±5%, ¼W
R770	1	1	1	RT05183140	Fixed, 18kΩ ±5%, ¼W
R771	1	1	1	RT05682140	Fixed, 6.8kΩ ±5%, ¼W
R772	1	1	1	GJ05331010	Fixed, 330Ω ±5%, 1W
R773	1	1	1	RT05184140	Fixed, 180kΩ ±5%, ¼W
R774	1	1	1	RT05393140	Fixed, 39kΩ ±5%, ¼W
R775	1	1	1	RC10022120	Fixed, 2.2Ω ±10%, ½W
R776	1	1	1	RC10022120	Fixed, 2.2Ω ±10%, ½W
R777	1	1	1	RC00000120	Fixed, 0Ω, ½W
R778	1	1	1	RC00000120	Fixed, 0Ω, ½W
R779	1	1	1	RC00000120	Fixed, 0Ω, ½W
<b>P700-CAPACITORS</b>					
C701	1	1	1	EE33502510	Electrolytic, 3.3μF ±20%, 25V
C702	1	1	1	EE33502510	Electrolytic, 3.3μF ±20%, 25V
C703	1	1	1	DD16201010	Ceramic, 200pF, 50V
C704	1	1	1	DD16201010	Ceramic, 200pF, 50V
C705	1	1	1	EE47601620	Electrolytic, 47μF ±20%, 16V
C706	1	1	1	EE47601620	Electrolytic, 47μF ±20%, 16V
C707	1	1	1	DD10030500	Ceramic, 3pF, 500V
C708	1	1	1	DD10030500	Ceramic, 3pF, 500V
C709	1	1	1	EA47605090	Electrolytic, 47μF +100%, -10%, 50V
C710	1	1	1	EA47605090	Electrolytic, 47μF +100%, -10%, 50V
C715	1	1	1	DK16101500	Ceramic, 100pF
C716	1	1	1	DK16101500	Ceramic, 100pF
C717	1	1	1	DF17104520	Film, 0.1μF, 200V
C718	1	1	1	DF17104520	Film, 0.1μF, 200V
C719	1	1	1	EA22705090	Electrolytic, 220μF +100%, -10%, 50V
C720	1	1	1	EA10603590	Electrolytic, 10μF +100%, -10%, 35V
C721	1	1	1	EA47601690	Electrolytic, 47μF +100%, -10%, 16V
C722	1	1	1	EA22701090	Electrolytic, 220μF +100%, -10%, 10V
<b>P700-SEMICONDUCTORS</b>					
H701	1	1	1	HT107222B0	Transistor, 2SA722 T or U
H702	1	1	1	HT107222B0	Transistor, 2SA722 T or U
H703	1	1	1	HT107222B0	Transistor, 2SA722 T or U
H704	1	1	1	HT107222B0	Transistor, 2SA722 T or U
H705	1	1	1	HV00003120	Varistor, MV-13

REF. DESIG.	Q'TY			PART NO.	DESCRIPTION
	U	C	E		
H706	1	1	1	HV00003120	Varistor, MV-13
H707	1	1	1	HT318853B0	Transistor, 2SC1885 C, Dor E
H708	1	1	1	HT318853B0	Transistor, 2SC1885 C, Dor E
H709	1	1	1	HT309451Q0	Transistor, 2SC945 Q
H710	1	1	1	HT309451Q0	Transistor, 2SC945 Q
H711	1	1	1	HT107331Q0	Transistor, 2SA733 Q
H712	1	1	1	HT107331Q0	Transistor, 2SA733 Q
H713	1	1	1	HD20002210	Diode, 1S2472 (Gr)
H714	1	1	1	HD20002210	Diode, 1S2472 (Gr)
H715	1	1	1	HD20002210	Diode, 1S2472 (Gr)
H716	1	1	1	HD20002210	Diode, 1S2472 (Gr)
H717	1	1	1	HD20002210	Diode, 1S2472 (Gr)
H718	1	1	1	HD20002210	Diode, 1S2472 (Gr)
H719	1	1	1	HD20002210	Diode, 1S2472 (Gr)
H720	1	1	1	HD20002210	Diode, 1S2472 (Gr)
H721	1	1	1	HT315672B0	Transistor, 2SC1567 Q or R
H722	1	1	1	HT315672B0	Transistor, 2SC1567 Q or R
H723	1	1	1	HT107942B0	Transistor, 2SA794 Q or R
H724	1	1	1	HT107942B0	Transistor, 2SA794 Q or R
H725	1	1	1	HD30030090	Diode, WZ-177
H726	1	1	1	HT309452A0	Transistor, 2SC945 Q or R
H727	1	1	1	HT309452A0	Transistor, 2SC945 Q or R
H728	1	1	1	HT313182C0	Transistor, 2SC1318 R or S
H729	1	1	1	HD20003210	Diode, 1S2471
H730	1	1	1	HV00003120	Varistor, MV-13
H731	1	1	1	HV00003120	Varistor, MV-13
H733	1	1	1	HD20005010	Diode, W06B
H734	1	1	1	HD20005010	Diode, W06B
H735	1	1	1	HD20005010	Diode, W06B
H736	1	1	1	HD20005010	Diode, W06B
<b>P700-MISCELLANEOUS</b>					
L701	1	1	1	LC22620010	Coil, 2.6μH
L702	1	1	1	LC22620010	Coil, 2.6μH
L703	1	1	1	LY20240090	Relay
P707	26	26	26	3444118050	Spacer, R723, R724, R735~R742, R745, R746, R765
P708	22	22	22	2933118020	Spacer, R753~R756, R759~R764, R772
J701	1	1	1	YP10001130	Plug
J729	29	29	29	YP10001130	Plug
<b>POWER SUPPLY CIRCUIT BOARD-P800</b>					
P800	1	1	1	YA22040310	P.W. Board, Power Supply
	1	1	1	ZZ22040310	P.W. Board Assembly
<b>P800-RESISTORS</b>					
R801	1	1	1	GJ05220020	Fixed, 22Ω ±5%, 2W
R802	1	1	1	GF05100140	Fixed, 10Ω ±5%, ¼W
R803	1	1	1	RT05152141	Fixed, 1.5kΩ ±5%, ¼W
R804	1	1	1	RT05152141	Fixed, 1.5kΩ ±5%, ¼W
R805	1	1	1	GJ05221030	Fixed, 220Ω ±5%, 3W
R806	1	1	1	RT05363141	Fixed, 36kΩ ±5%, ¼W
R807	1	1	1	RT05273141	Fixed, 27kΩ ±5%, ¼W
R808	1	1	1	RA05020130	Trimming, 5kΩ (B)
<b>P800-CAPACITORS</b>					
C801	1	1	1	DK18103510	Ceramic, 0.01μF, 500V
C802	1	1	1	EA47706310	Electrolytic, 470μF, 63V



U: For U.S.A.  
C: For Canada  
E: For Europe

REF. DESIG.	Q'TY			PART NO.	DESCRIPTION
	U	C	E		
C803	1	1	1	EA47705090	Electrolytic, 470 $\mu$ F, 50V
C804	1	1	1	EA10705090	Electrolytic, 100 $\mu$ F, 50V
C805	1	1	1	DF17473050	Film, 0.047 $\mu$ F, 50V
C806	1	1	1	DK18403020	Ceramic, 0.04 $\mu$ F, 50V
C807	1	1	1	EA33505090	Electrolytic, 3.3 $\mu$ F, 50V
C808	1	1	1	EA47701690	Electrolytic, 470 $\mu$ F, 16V
C809	1	1	1	EA10801090	Electrolytic, 1000 $\mu$ F, 10V
<b>P800-SEMICONDUCTORS</b>					
Q801	1	1	1	HD20012030	Diode, DS132 B
Q802	1	1	1	HD20011030	Diode, DS131 B
Q803	1	1	1	HT403302A0	Transistor, 2SD330 D or E
Q804	1	1	1	HT309452A0	Transistor, 2SC945 Q or R
Q805	1	1	1	HD30021090	Diode, BZ-140 14V
Q806	1	1	1	HD20004130	Diode, S1B01-02
<b>P800-MISCELLANEOUS</b>					
J801	?	?	?	?	?
J814	14	14	14	YJ10001140	Plug
J815	?	?	?	?	?
J818	4	4	4	YJ08000210	Socket, Fuse
F801	1	1	1	FS10100080	Fuse, MGC 1A (30 mm)
F802	1	1	1	FS10200060	Fuse, MGC 2A (30 mm)
F801	1	1	1	FS10100900	Fuse, SLA 1A (20 mm)
F802	1	1	1	FS10200900	Fuse, SLA 2A (20 mm)
P803	10	10	10	2933118020	Spacer, R801, R802, R805, Q806, Q801, Q802
<b>PRE &amp; TONE AMP. CIRCUIT BOARD-PE01</b>					
PE01	1	1	1	YD29151082	P.W. Board, Pre & Tone Amp.
	1	1	1	ZZ22041082	P.W. Board Assembly
<b>PE01-RESISTORS</b>					
RE01	1	1	1	RT05474140	Fixed, 470k $\Omega$ $\pm$ 5%, 1/4W
RE02	1	1	1	RT05474140	Fixed, 470k $\Omega$ $\pm$ 5%, 1/4W
RE03	1	1	1	RT05391140	Fixed, 390 $\Omega$ $\pm$ 5%, 1/4W
RE04	1	1	1	RT05391140	Fixed, 390 $\Omega$ $\pm$ 5%, 1/4W
RE05	1	1	1	RN05105140	Fixed, 1M $\Omega$ $\pm$ 5%, 1/4W
RE06	1	1	1	RN05105140	Fixed, 1M $\Omega$ $\pm$ 5%, 1/4W
RE07	1	1	1	RN05104140	Fixed, 100k $\Omega$ $\pm$ 5%, 1/4W
RE08	1	1	1	RT05103140	Fixed, 10k $\Omega$ $\pm$ 5%, 1/4W
RE09	1	1	1	RT05273140	Fixed, 27k $\Omega$ $\pm$ 5%, 1/4W
RE10	1	1	1	RT05273140	Fixed, 27k $\Omega$ $\pm$ 5%, 1/4W
RE11	1	1	1	RT05102140	Fixed, 1k $\Omega$ $\pm$ 5%, 1/4W
RE12	1	1	1	RT05102140	Fixed, 1k $\Omega$ $\pm$ 5%, 1/4W
RE13	1	1	1	RT05752140	Fixed, 7.5k $\Omega$ $\pm$ 5%, 1/4W
RE14	1	1	1	RT05752140	Fixed, 7.5k $\Omega$ $\pm$ 5%, 1/4W
RE15	1	1	1	RT05102140	Fixed, 1k $\Omega$ $\pm$ 5%, 1/4W
RE16	1	1	1	RT05102140	Fixed, 1k $\Omega$ $\pm$ 5%, 1/4W
RE17	1	1	1	RT05474140	Fixed, 470k $\Omega$ $\pm$ 5%, 1/4W
RE18	1	1	1	RT05474140	Fixed, 470k $\Omega$ $\pm$ 5%, 1/4W
RE19	1	1	1	RT05562140	Fixed, 5.6k $\Omega$ $\pm$ 5%, 1/4W
RE20	1	1	1	RT05562140	Fixed, 5.6k $\Omega$ $\pm$ 5%, 1/4W
RE21	1	1	1	RT05123140	Fixed, 12k $\Omega$ $\pm$ 5%, 1/4W
RE22	1	1	1	RT05123140	Fixed, 12k $\Omega$ $\pm$ 5%, 1/4W
RE23	1	1	1	RT05334140	Fixed, 330k $\Omega$ $\pm$ 5%, 1/4W
RE24	1	1	1	RT05334140	Fixed, 330k $\Omega$ $\pm$ 5%, 1/4W
RE25	1	1	1	RT05562140	Fixed, 5.6k $\Omega$ $\pm$ 5%, 1/4W
RE26	1	1	1	RT05562140	Fixed, 5.6k $\Omega$ $\pm$ 5%, 1/4W
RE27	1	1	1	RT05562140	Fixed, 5.6k $\Omega$ $\pm$ 5%, 1/4W

REF. DESIG.	Q'TY			PART NO.	DESCRIPTION
	U	C	E		
RE28	1	1	1	RT05562140	Fixed, 5.6k $\Omega$ $\pm$ 5%, 1/4W
RE29	1	1	1	RT05273140	Fixed, 27k $\Omega$ $\pm$ 5%, 1/4W
RE30	1	1	1	RT05273140	Fixed, 27k $\Omega$ $\pm$ 5%, 1/4W
RE31	1	1	1	RT05123140	Fixed, 12k $\Omega$ $\pm$ 5%, 1/4W
RE32	1	1	1	RT05123140	Fixed, 12k $\Omega$ $\pm$ 5%, 1/4W
RE33	1	1	1	RT05153140	Fixed, 15k $\Omega$ $\pm$ 5%, 1/4W
RE34	1	1	1	RT05153140	Fixed, 15k $\Omega$ $\pm$ 5%, 1/4W
RE35	1	1	1	RT05334140	Fixed, 330k $\Omega$ $\pm$ 5%, 1/4W
RE36	1	1	1	RT05334140	Fixed, 330k $\Omega$ $\pm$ 5%, 1/4W
RE37	1	1	1	RT05273140	Fixed, 27k $\Omega$ $\pm$ 5%, 1/4W
RE38	1	1	1	RT05273140	Fixed, 27k $\Omega$ $\pm$ 5%, 1/4W
RE39	1	1	1	RT05225140	Fixed, 2.2M $\Omega$ $\pm$ 5%, 1/4W
RE40	1	1	1	RT05225140	Fixed, 2.2M $\Omega$ $\pm$ 5%, 1/4W
RE41	1	1	1	RT05683140	Fixed, 68k $\Omega$ $\pm$ 5%, 1/4W
RE42	1	1	1	RT05683140	Fixed, 68k $\Omega$ $\pm$ 5%, 1/4W
RE43	1	1	1	RT05473140	Fixed, 47k $\Omega$ $\pm$ 5%, 1/4W
RE44	1	1	1	RT05473140	Fixed, 47k $\Omega$ $\pm$ 5%, 1/4W
RE45	1	1	1	RT05103140	Fixed, 10k $\Omega$ $\pm$ 5%, 1/4W
RE46	1	1	1	RT05103140	Fixed, 10k $\Omega$ $\pm$ 5%, 1/4W
RE47	1	1	1	RT05221140	Fixed, 220 $\Omega$ $\pm$ 5%, 1/4W
RE48	1	1	1	RT05221140	Fixed, 220 $\Omega$ $\pm$ 5%, 1/4W
RE49	1	1	1	RT05474140	Fixed, 470k $\Omega$ $\pm$ 5%, 1/4W
RE50	1	1	1	RT05474140	Fixed, 470k $\Omega$ $\pm$ 5%, 1/4W
RE51	1	1	1	RD01040052	Variable, Treble, 100k $\Omega$ (B)
RE52	1	1	1	RD01040052	Variable, Mid, 100k $\Omega$ (B)
RE53	1	1	1	RD01040052	Variable, Bass, 100k $\Omega$ (B)
RE54	1	1	1	RT05821140	Fixed, 820 $\Omega$ $\pm$ 5%, 1/4W
RE55	1	1	1	RC00000120	Fixed, 0 $\Omega$ , 1/4W
RE56	1	1	1	RC00000120	Fixed, 0 $\Omega$ , 1/4W
<b>PE01-CAPACITORS</b>					
CE01	1	1	1	DF17224050	Film, 0.22 $\mu$ F $\pm$ 20%, 50V
CE02	1	1	1	DF17224050	Film, 0.22 $\mu$ F $\pm$ 20%, 50V
CE03	1	1	1	EA10603590	Electrolytic, 10 $\mu$ F +100%, -10%, 35V
CE04	1	1	1	EA10603590	Electrolytic, 10 $\mu$ F +100%, -10%, 35V
CE05	1	1	1	EE47502510	Electrolytic, 4.7 $\mu$ F $\pm$ 20%, 25V
CE06	1	1	1	EE47502510	Electrolytic, 4.7 $\mu$ F $\pm$ 20%, 25V
CE07	1	1	1	DD16101010	Ceramic, 100pF $\pm$ 10%, 50V
CE08	1	1	1	DD16101010	Ceramic, 100pF $\pm$ 10%, 50V
CE09	1	1	1	DF16222050	Film, 0.0022 $\mu$ F $\pm$ 10%, 50V
CE10	1	1	1	DF16122650	Film, 0.0022 $\mu$ F $\pm$ 10%, 50V
CE11	1	1	1	DF16472050	Film, 0.0047 $\mu$ F $\pm$ 10%, 50V
CE12	1	1	1	DF16472050	Film, 0.0047 $\mu$ F $\pm$ 10%, 50V
CE13	1	1	1	DF16223050	Film, 0.022 $\mu$ F $\pm$ 10%, 50V
CE14	1	1	1	DF16223050	Film, 0.022 $\mu$ F $\pm$ 10%, 50V
CE15	1	1	1	DF16223050	Film, 0.022 $\mu$ F $\pm$ 10%, 50V
CE16	1	1	1	DF16223050	Film, 0.022 $\mu$ F $\pm$ 10%, 50V
CE17	1	1	1	DF16822050	Film, 0.0082 $\mu$ F $\pm$ 10%, 50V
CE18	1	1	1	DF16822050	Film, 0.0082 $\mu$ F $\pm$ 10%, 50V
CE19	1	1	1	EE10505010	Electrolytic, 1 $\mu$ F $\pm$ 20%, 50V
CE20	1	1	1	EE10505010	Electrolytic, 1 $\mu$ F $\pm$ 20%, 50V
CE21	1	1	1	EE33505010	Electrolytic, 3.3 $\mu$ F $\pm$ 20%, 50V
CE22	1	1	1	EE33505010	Electrolytic, 3.3 $\mu$ F $\pm$ 20%, 50V
CE23	1	1	1	EQ10505010	Electrolytic, 1 $\mu$ F $\pm$ 30%, 50V
CE24	1	1	1	EQ10505010	Electrolytic, 1 $\mu$ F $\pm$ 30%, 50V
CE25	1	1	1	EA22703590	Electrolytic, 220 $\mu$ F +100%, -10%, 35V
<b>PE01-MISCELLANEOUS</b>					
HE01	1	1	1	HT313283A0	Transistor, 2SC1328 S, T or U
HE02	1	1	1	HT313283A0	Transistor, 2SC1328 S, T or U
HE03	1	1	1	HT107222A0	Transistor, 2SA722 S or T



U : For U.S.A.  
C : For Canada  
E : For Europe

REF. DESIG.	Q'TY			PART NO.	DESCRIPTION
	U	C	E		
HE04	1	1	1	HT107222A0	Transistor, 2SA722 S or T
HE05	1	1	1	HT313283A0	Transistor, 2SC1328 S, T or U
HE06	1	1	1	HT313283A0	Transistor, 2SC1328 S, T or U
HE07	1	1	1	HT107222A0	Transistor, 2SA722 S or T
HE08	1	1	1	HT107222A0	Transistor, 2SA722 S or T
PE08	2	2	2	2933118020	Spacer, RE54
JE01 ? JE08	8	8	8	YP10001130	Plug
					<b>FILTER &amp; DOLBY CIRCUIT BOARD-PH01</b>
PH01	1	1		YD29151090	P.W. Board, Filter & Dolby
	1	1		ZZ22041090	P.W. Board Assembly
			1	YD29150050	P.W. Board, Low & Hi Filter
			1	ZZ22048050	P.W. Board Assembly
RH01	1	1		RT05102140	Resistor, Fixed, 1kΩ ±5%, ¼W
RH02	1	1		RT05102140	Resistor, Fixed, 1kΩ ±5%, ¼W
RH04	1	1		RT05105140	Resistor, Fixed, 1MΩ ±5%, ¼W
RH05	1	1		RT05105140	Resistor, Fixed, 1MΩ ±5%, ¼W
RH06	1	1		RT05472140	Resistor, Fixed, 4.7kΩ ±5%, ¼W
RH07	1	1		RT05472140	Resistor, Fixed, 4.7kΩ ±5%, ¼W
RH08	1	1		RT05225140	Resistor, Fixed, 2.2MΩ ±5%, ¼W
RH09	1	1		RT05225140	Resistor, Fixed, 2.2MΩ ±5%, ¼W
CH01	1	1		DF15222050	Capacitor, Film, 0.0022μF ±10%, 50V
CH02	1	1		DF15222050	Capacitor, Film, 0.0022μF ±10%, 50V
CH03	1	1		DF16682050	Capacitor, Film, 0.0068μF ±10%, 50V
CH04	1	1		DF16682050	Capacitor, Film, 0.0068μF ±10%, 50V
CH05	1	1		EV22403510	Capacitor, Electrolytic, 0.22μF ±20%, 35V
CH06	1	1		EV22403510	Capacitor, Electrolytic, 0.22μF ±20%, 35V
SH01	1	1		SP04040140	Pushswitch
JH01	1	1		YP10001200	Plug
JH02	1	1		YP10001200	Plug
JH09 ? JH28	20	20		YP10001200	Plug
					<b>LOW &amp; HIGH FILTERS CIRCUIT BOARD-PH01</b>
PH01			1	YD29150050	P.W. Board, Low & Hi Filters
			1	ZZ22048090	P.W. Board Assembly
					<b>PH01-MISCELLANEOUS</b>
RH01	1			RT05102140	Resistor, Fixed, 1kΩ ±5%, ¼W
RH02	1			RT05102140	Resistor, Fixed, 1kΩ ±5%, ¼W
RH06	1			RT05472140	Resistor, Fixed, 4.7kΩ ±5%, ¼W
RH07	1			RT05472140	Resistor, Fixed, 4.7kΩ ±5%, ¼W
RH08	1			RT05225140	Resistor, Fixed, 2.2MΩ ±5%, ¼W

REF. DESIG.	Q'TY			PART NO.	DESCRIPTION
	U	C	E		
RH09			1	RT05225140	Resistor, Fixed, 2.2MΩ ±5%, ¼W
CH01			1	DF16333050	Capacitor, Film, 0.033μF ±10%, 50V
CH02			1	DF16333050	Capacitor, Film, 0.033μF ±10%, 50V
CH03			1	DF16682050	Capacitor, Film, 0.0068μF ±10%, 50V
CH04			1	DF16682050	Capacitor, Film, 0.0068μF ±10%, 50V
SH01			1	SP04040130	Pushswitch
JH01 ? JH17			17	YP10001200	Plug
					<b>SPEAKER SWITCH CIRCUIT BOARD-PT01</b>
PT01	1	1	1	YD29151100	P.W. Board, Speaker Switch
	1	1	1	ZZ22043100	P.W. Board Assembly
					<b>PT01-MISCELLANEOUS</b>
RT01	1	1	1	RT05683140	Resistor, Fixed, 68kΩ ±5%, ¼W
RT02	1	1	1	RT05683140	Resistor, Fixed, 68kΩ ±5%, ¼W
RT03	1	1	1	RT05153140	Resistor, Fixed, 15kΩ ±5%, ¼W
RT04	1	1	1	RT05153140	Resistor, Fixed, 15kΩ ±5%, ¼W
RT05	1	1	1	GJ05331020	Resistor, Fixed, 330Ω ±5%, 2W
RT06	1	1	1	GJ05331020	Resistor, Fixed, 330Ω ±5%, 2W
RT07	1	1	1	GU05151120	Resistor, Fixed, 150Ω ±5%, ½W
RT08	1	1	1	GU05151120	Resistor, Fixed, 150Ω ±5%, ½W
CT01	1	1	1	DD16121010	Capacitor, Ceramic, 120pF ±10%, 50V
CT02	1	1	1	DD16121010	Capacitor, Ceramic, 120pF ±10%, 50V
CT03	1	1	1	DF16273050	Capacitor, Film, 0.027μF ±10%, 50V
CT04	1	1	1	DF16273050	Capacitor, Film, 0.027μF ±10%, 50V
ST01	1	1	1	SP04040110	Pushswitch
PT07	4	4	4	3444118050	Spacer, RT05, RT06
JT01 ? JT16	16	16	16	YP10001200	Plug
					<b>DIAL LAMP CIRCUIT BOARD-PZ01</b>
PZ01	1	1	1	YD28860160	P.W. Board, Dial Lamp
	1	1	1	ZZ22041160	P.W. Board Assembly
					<b>PZ01-MISCELLANEOUS</b>
MZ01 ? MZ05	5	5	5	IN10080070	Lamp
JZ01 ? JZ10 JZ11 ? JZ14	10	10	10	YJ08000170	Socket
	4	4	4	YP10001200	Plug



U : For U.S.A.  
 C : For Canada  
 E : For Europe

REF. DESIG.	Q'TY			PART NO.	DESCRIPTION
	U	C	E		
<b>GENERAL MISCELLANEOUS</b>					
M001	1	1	1	IM11042270	DC Meter, Signal Strength
M002	1	1	1	IM11042240	DC Meter, Tuning
M003	1	1	1	IN10080340	Lamp, Stereo Indicator
M005	1	1	1	IN10080070	Lamp, Meter Indicator
M006	1	1	1	IN10080070	Lamp, Meter Indicator
L001	1	1	1	LF11200460	Antenna Coil, AM
L002	1	1	1	LC11540020	Choke Coil
L003	1	1		TS19609010	Power Transformer
L003			1	TS19609020	Power Transformer
S001	1	1	1	SP02010150	Power Switch
C001	1	1	1	DK18103010	Capacitor, Ceramic, 0.01 $\mu$ F, 50V
C002	1	1	1	DK18103010	Capacitor, Ceramic, 0.01 $\mu$ F, 50V
C003	1	1	1	EC10905020	Capacitor, Electrolytic, 10000 $\mu$ F, 50V
C004	1	1	1	EC10905020	Capacitor, Electrolytic, 10000 $\mu$ F, 50V
C006		1		DF17473590	Capacitor, Film, 0.047 $\mu$ F
C006			1	DF17223800	Capacitor, Film, 0.02 $\mu$ F, 1000V
C007	1	1	1	DK18103510	Capacitor, Ceramic, 0.01 $\mu$ F, 500V
G001	1			BF10400040	Printed Comp.
R001	1	1	1	RS05040050	Resistor, Variable, Balance, 500k $\Omega$
R002	1	1	1	RM02540220	Resistor, Variable, Volume, 250k $\Omega$
R003	1	1		RC10225120	Resistor, Fixed, 2.2M $\Omega$ $\pm$ 10%, 1/2W
H007	1	1	1	HD20004290	Diode, S5VB
J001	1	1	1	BY04050010	Terminal, Antenna
J002	1	1	1	YL01020030	Terminal, 2P Lug
J003	1	1	1	YT01010050	Terminal, Ground
J004	1	1	1	YT02040140	Terminal, Phono/Aux
J005	1	1	1	YT02040140	Terminal, Tape 1
J006	1	1	1	YT02040140	Terminal, Tape 2
J007	1	1	1	YT02040170	Terminal, Pre Out/Main In
J008	1	1	1	YT02010130	Terminal, Quadradial Output
J009	1	1	1	YJ05000220	Socket, Transistor
J010	1	1	1	YJ05000220	Socket, Transistor
J011	1	1	1	YJ05000220	Socket, Transistor
J012	1	1	1	YJ05000220	Socket, Transistor
J013	1	1	1	YT03040160	Terminal, Speaker (System 1)
J014	1	1	1	YT03040160	Terminal, Speaker (System 2)
J015	1	1	1	YJ01000980	Jack, Headphones
J016	1	1	1	YJ08000190	Socket, Meter Lamp Holder
J017	1	1	1	YJ08000190	Socket, Meter Lamp Holder
J018	1	1		YJ08000120	Socket, Fuse Holder
J018			1	YJ08000220	Socket, Fuse Holder
J019	1	1	1	YJ04000570	Socket, AC Outlet (Switched)
J020	1	1	1	YJ04000570	Socket, AC Outlet (Unswitched)
J021			1	BY03110010	Terminal, Voltage Conversion
H001	1	1	1	HT403883A0	Transistor, 2SD388 S, R or Q
H002	1	1	1	HT403883A0	Transistor, 2SD388 S, R or Q
H003	1	1	1	HT205413A0	Transistor, 2SB541 S, R or Q
H004	1	1	1	HT205413A0	Transistor, 2SB541 S, R or Q
H005	1	1	1	HV00005080	Varistor, STV-3H

REF. DESIG.	Q'TY			PART NO.	DESCRIPTION
	U	C	E		
H006	1	1	1	HV00005080	Varistor, STV-3H
W001	1	1		YC02400220	AC Cord, UL
W001			1	YC01900030	AC Cord
F001			1	FS10250900	Fuse, 2.5A SGA (20 mm)
F001	1	1		FS10400050	Fuse, 4A MGC (30 mm)
F002		1		FS20500900	Fuse, 5A
2121	1	1	1	2991109010	Shield, HB112
2122	1	1	1	2991053110	Cover, VB116

**12. TECHNICAL SPECIFICATIONS**

**AMPLIFIER SECTION:**

Rated Power Output, Minimum Continuous Average Power per Channel, both Channels Driven . . . . .	38 W
Power Band . . . . .	20 Hz to 20 kHz
Total Harmonic Distortion . . . . .	0.1%
Load Impedance . . . . .	8 ohms
Maximum Power Output, DIN 45500 (Less than 1% THD, 10 min. test at 1 kHz) . . . . .	42 W
Power Bandwidth at 1% THD, DIN 45500 . . . . .	10 Hz to 70 kHz
I.M. Distortion (I.H.F. method, 60 Hz and 7 kHz mixed 4:1 at rated power output) . . . . .	0.1%
Damping Factor . . . . .	45
Sensitivity (at MAIN IN) . . . . .	1.5 V
Impedance (at MAIN IN) . . . . .	30 kohms
Frequency Response for Power Amp Only (at 1 W output, 20 Hz to 20 kHz) . . . . .	±0.25 dB

**PREAMPLIFIER SECTION:**

<b>Phono</b>	
Input Overload at 1 kHz . . . . .	100 mV
Equivalent Input Noise . . . . .	1.5 μV
Dynamic Range (Dynamic Range is the ratio of input overload to equivalent input noise.) . . . . .	96 dB
Input Sensitivity . . . . .	1.8 mV
Input Impedance . . . . .	47 kohms
Frequency Response, RIAA 20 Hz to 20 kHz . . . . .	±1.0 dB
Signal-to-Noise Ratio (at rated output and 7.75 mV input) . . . . .	75 dB
Signal-to-Noise Ratio, unweighted (DIN 45500) . . . . .	47 dB
<b>High Level (Aux and Tape)</b>	
Input Sensitivity . . . . .	180 mV
Input Impedance . . . . .	85 kohms
Frequency Response (includes power amp) . . . . .	15 Hz to 60 kHz, ±1.5 dB
Signal-to-Noise Ratio (ref. to rated output and 775 mV input) . . . . .	87 dB
<b>Output Levels</b>	
Tape Out (ref. 7.75 mV at Phono inputs) . . . . .	775 mV
Pre-Out (ref. 180 mV at Aux inputs) . . . . .	1.5 V
(ref. 500 mV at Aux inputs, main amp disconnected) . . . . .	4.2 V
<b>Output Impedance</b>	
Tape Out . . . . .	600 ohms
Pre-Out . . . . .	900 ohms

**FM TUNER SECTION:**

<b>Sensitivity</b>	
IHF Usable . . . . .	10.8 dBf (1.9 μV)
IHF 50 dB Quieting (mono) . . . . .	17.3 dBf (4.0 μV)
(Stereo) . . . . .	37.2 dBf (40 μV)
DIN Sensitivity (Mono, 26 dB S/N, 300 ohm input) . . . . .	1.6 μV
(Stereo, 46 dB S/N, 300 ohm input) . . . . .	80 μV
<b>Quieting Slope (Mono)</b>	
RF Input for 30 dB Quieting . . . . .	9.8 dBf (1.7 μV)
Quieting at:	
20 dBf ( 5.5 μV) . . . . .	51 dB
25 dBf ( 10 μV) . . . . .	58 dB
40 dBf ( 55 μV) . . . . .	65 dB
65 dBf (1000 μV) . . . . .	72 dB
<b>Quieting Slope (Stereo)</b>	
Quieting at:	
30 dBf ( 17 μV) . . . . .	40 dB
40 dBf ( 55 μV) . . . . .	50 dB
50 dBf ( 173 μV) . . . . .	56 dB
65 dBf (1000 μV) . . . . .	62 dB



Distortion (Mono)	
at 50 dB Quieting, 1000 Hz	0.6%
at 65 dBf (1000 $\mu$ V), 1000 Hz	0.15%
Distortion (Stereo)	
at 50 dB Quieting, 1000 Hz	0.6%
at 65 dBf (1000 $\mu$ V), 1000 Hz	0.3%
Hum and Noise	
at 65 dBf (1000 $\mu$ V)	
Mono	70 dB
Stereo	62 dB
Frequency Response	
30 Hz to 15 kHz	
Mono	+0.2, -2.0 dB
Stereo	$\pm$ 2.0 dB
Capture Ratio	
at 45 dBf (100 $\mu$ V)	1.5 dB
at 65 dBf (1000 $\mu$ V)	1.0 dB
Alternate Channel Selectivity	70 dB
Spurious Response Rejection	90 dB
Image Response Rejection	60 dB
I.F. Rejection (Balanced)	90 dB
A.M. Suppression	50 dB
Stereo Separation	
100 Hz	42 dB
1000 Hz	45 dB
10 kHz	32 dB
Subcarrier Rejection	60 dB

#### AM TUNER SECTION:

IHF Usable Sensitivity	20 $\mu$ V
Distortion (THD), 30% Modulation	0.6%
Signal-to-Noise Ratio	49 dB
Frequency Response ( $\pm$ 3 dB)	40 Hz to 2.3 kHz
Alternate Channel Selectivity	46 dB
Image Rejection	45 dB
Spurious Response Rejection	50 dB
I.F. Rejection	40 dB

#### GENERAL:

Power Requirements	120 V AC, 60 Hz (U.S.A. and Canadian Versions) 220 V AC, 50 Hz (European Version)
(This unit can be converted by a qualified technician to operate on 110/120/240 V AC, 50/60 Hz.)	
Power Consumption at rated output, both channels operating	170 W
Idling Power (Volume Control at zero)	30 W
Semiconductor Complement:	
Integrated Circuits	3
Transistors	45
Diodes	29
Field Effect Transistors	1
Dimensions:	
Panel Width	440 mm (17-5/16 inches)
Panel Height	137 mm ( 5-3/8 inches)
Depth	365 mm (14-3/8 inches)
Weight:	
Unit alone	12 kg (26.4 lbs)
Packed for shipment	15 kg ( 33 lbs)

model 2238



**marantz**

**MARANTZ CO., INC. • P.O. BOX 577 • CHATSWORTH, CALIFORNIA • 91311**

A WHOLLY-OWNED SUBSIDIARY OF SUPERSCOPE INC., CHATSWORTH, CALIFORNIA • 91311

"DOLBY" is a trademark of Dolby Laboratories, Inc.



2238

**marantz**

**SERVICE BULLETIN**

model number 2238	bulletin number <b>M-2238-1</b>
for serial numbers ALL	
subject SERVICE MANUAL CORRECTION	
technical services approval <i>[Signature]</i>	writer <i>SKJ</i>
engineering approval <i>[Signature]</i>	date 6-1-77

OBJECTIVE

This bulletin is issued to inform you of a misprint in the Marantz Model 2238 Service Manual.

APPLICATION

Incorporate this change into your Service Manual as soon as possible to ensure correct service information.

PROCEDURE

- A. Refer to the Service Manual, pages 12, 14, and 22, Schematic Diagrams and change the Ref. Desig. H707 to H709 of the transistor on the P700, Main Amp PC Board as shown by the illustration below.

