

### 3. TEST EQUIPMENT REQUIRED FOR SERVICING

This table lists the test equipment required for servicing the Model 2238B Receiver.

Item	Manufacturer and Model No.	Use
AM Signal Generator		Signal source for AM alignment
Test Loop		Use with AM Signal Generator
FM Signal Generator MPX Signal Generator	Sound Technology Model 1000A	Signal source for FM alignment Stereo separation alignment and trouble shooting
Distortion Analyzer Audio Oscillator AC VTVM	Sound Technology Model 1700A	Distortion measurements Sinewave and squarewave signal source Voltage measurements (AC)
Oscilloscope	Tektronix Model T932 Philips Model 3232	Waveform analysis and trouble shooting and ASO alignment
Frequency Counter	Fluke Model 1900A	MPX Oscillator adjustment (VCO)
Circuit Tester		Trouble shooting
DC VTVM	Fluke Model 8000 "Digital" Simpson Model 313, Triplet Model 801	Voltage measurements (DC)
AC Wattmeter	Simpson Model 1379	Monitors primary power to amplifier
AC Ammeter	Commercial Grade (1~10A)	Monitors amplifier output under short circuit condition
Line Voltmeter	Simpson Model 1359	Monitors potential of primary power to amplifier
Variable Autotransformer	Superior Electronic Co., Powerstat Model 116B-10A	Adjusts level of primary power to amplifier
Shorting Plug	Use phono plug with 600-ohm across center pin and shell	Shorts amplifier input to eliminate noise pickup
Output Load (8 ohms, $\pm 0.5\%$ , 100W)	Commercial Grade	Provides 8-ohm load for amplifier output termination
Output Load (4 ohms, $\pm 0.5\%$ , 100W)	Commercial Grade	Provides 4-ohm load for amplifier output termination

### 4. AM ALIGNMENT PROCEDURE

#### 4.1 AM IF ALIGNMENT

1. Connect a sweep generator to the L153 and an alignment scope to the J233.
2. Rotate each core of IF transformers L155 and L156 for the maximum height and flat top symmetrical response.

#### 4.2 AM FREQUENCY RANGE AND TRACKING ALIGNMENT

1. Set AM signal generator to 515 kHz. Turn the tuning capacitor fully closed (place the tuning pointer at the low end) and adjust the oscillator coil L154 for maximum audio output.

2. Set the signal generator to 1650 kHz. Place the tuning pointer in the high frequency end and adjust the oscillator trimmer on the oscillator tuning capacitor for maximum audio output.
3. Repeat steps 1 and 2 until no further adjustment is necessary.
4. Set the generator to 600 kHz, tune the receiver to the same frequency and adjust a slug core of AM ferrite-rod antenna L001 for maximum output.
5. Set the generator to 1400 kHz and tune the receiver to the same frequency and adjust the trimming capacitor on the antenna tuning capacitor for maximum output.
6. Repeat procedures 4 and 5 until no further adjustment is necessary.

#### NOTE

During tracking alignment reduce the signal generator output as necessary to avoid AGC action.

### 5. FM ALIGNMENT PROCEDURE

#### 5.1 FM FREQUENCY RANGE AND TRACKING ALIGNMENT

1. Connect an FM signal generator to the FM antenna terminals and oscilloscope and an audio distortion analyzer to the TAPE OUT jacks on the rear panel.
2. Set the generator to 87.4 MHz and provide about 3 to 5  $\mu\text{V}$ . Place the tuning pointer at the low frequency end by rotating the tuning knob and adjust the pitch of oscillator coil L107 to obtain maximum audio output.
3. Set the generator to 109 MHz and provide about 3 to 5  $\mu\text{V}$ . Rotate the tuning knob and place the tuning pointer at the high frequency end and adjust the trimming capacitor C121 for maximum output.
4. Repeat steps 2 and 3 until no further adjustment is necessary.
5. Set the generator to 90 MHz and tune the receiver to the same frequency. Decrease signal generator output until the audio output level decreases with the decreasing generator output. Adjust the pitch of antenna coil L102 and RF coil L104 for maximum output.
6. Set the generator to 106 MHz and tune the receiver to the same frequency. Decrease the signal generator output until the audio output level decreases with the decreasing generator output. Adjust the trimming capacitors of antenna and RF tuning circuits for maximum output.
7. Repeat steps 5 and 6 until no further adjustment is necessary.
8. Adjust the primary core (lower core) of discriminator transformer L202 so that the center tuning meter pointer indicates its center at no signal applied. Set the

FM signal generator to 98 MHz and increase its output level 1  $\text{k}\mu\text{V}$  and tune the receiver to the same frequency so that the center tuning meter pointer indicates its center. Adjust the secondary core (upper core) of L202 for minimum distortion.

#### 5.2 STEREO SEPARATION ALIGNMENT

1. Set the FM signal generator to provide 1  $\text{k}\mu\text{V}$  at 98 MHz. Tune the receiver to the same frequency so that the center tuning meter pointer indicates its center. Then turn off the modulation of the generator, connect a frequency counter to test point J229 and adjust R301 so that the frequency counter may precisely read 76 kHz.
2. Modulate the generator with stereo composite signal consisting of only L or R channel (of course a pilot signal must be included).
3. Adjust the trimming resistor R317 for maximum and same separation in both channels.

#### 5.3 MUTING THRESHOLD ADJUSTMENT

1. Set the FM signal generator output to provide 12.5  $\mu\text{V}$  (IHF) at 98 MHz and tune receiver to the same frequency. Adjust the trimming resistor R212 for the threshold level of 12.5  $\mu\text{V}$ . (During this adjustment turn the FM MUTING pushswitch "on".)

#### 5.4 FM DOLBY LEVEL ADJUSTMENT

1. Set the FM signal generator to provide a 400 Hz, 50% modulated 98 MHz mono signal, at 1  $\text{k}\mu\text{V}$  output. Precisely tune the receiver to 98 MHz.
2. Depress the FM 25 $\mu\text{S}$  pushswitch, and adjust R215 until the outputs of both channels are 580 mV.

### 6. POWER AMPLIFIER ADJUSTMENT

Connect a VTVM between R763(+) and R765(-) and adjust the trimming resistor R731 until the VTVM reads 23 mV DC. And next, connect a VTVM between J717 and J714(GROUND) and adjust the trimming resistor R711 until the VTVM reads 0 mV DC. Do over again. For the other channel, connect the VTVM between R764(+) and R766(-) and adjust the R732 for the same reading, and connect the VTVM between J718 and J714 and adjust the R712 for the same reading. Do over again. When adjusting a DC offset voltage, the switch of the SPEAKER SYSTEM-1 must be turned on.

### 7. POWER SUPPLY ADJUSTMENT

Connect a VTVM between J722(+) and J724(-) and adjust R787 until the VTVM reads 35.0 V under no signal condition.

11.2 Dial Lamp Assembly (PZ01) Schematic Diagram and Component Locations

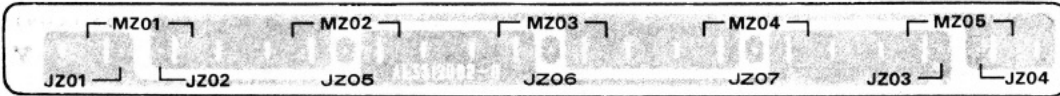
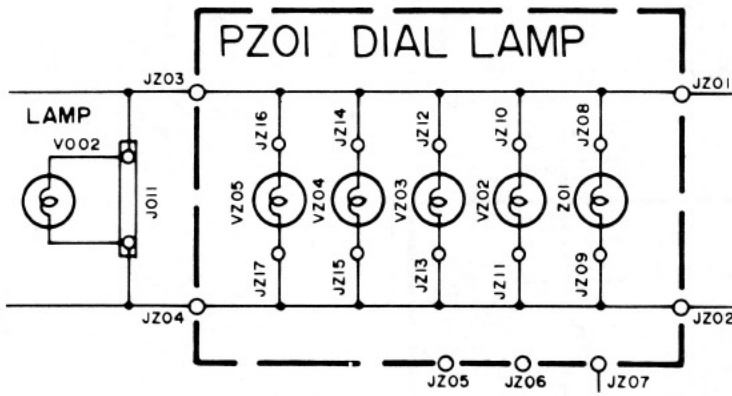

11.3 DLB-1 Socket Assembly (PK01) Schematic Diagram and Component Locations

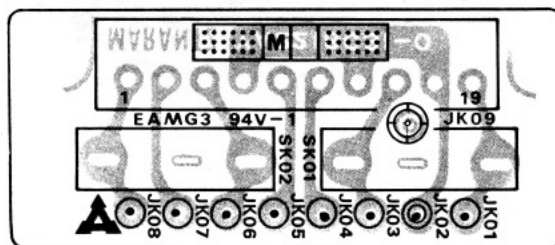
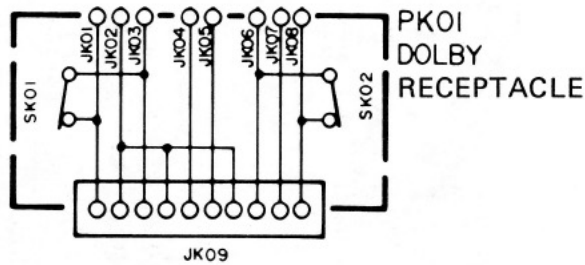

# EQ Amp. Assembly (P400) Schematic Diagram and Component Locations

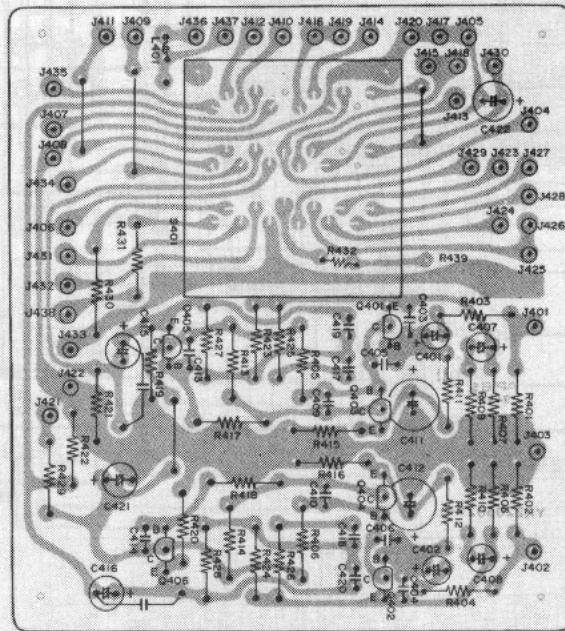
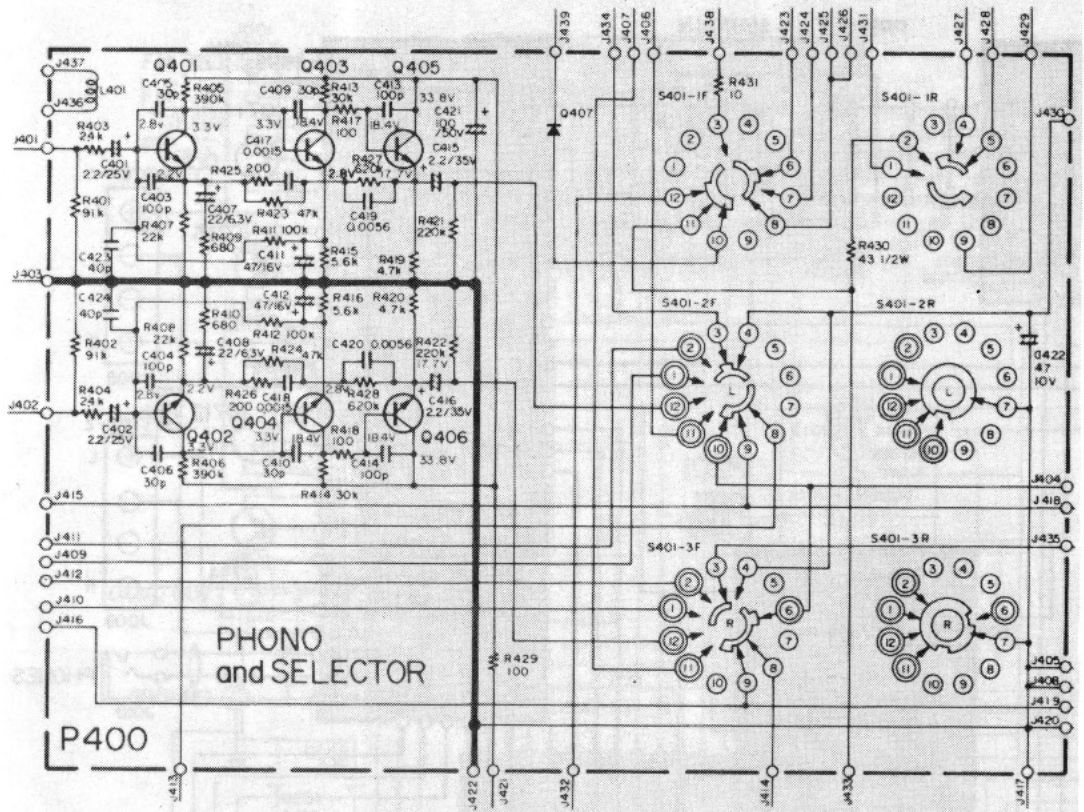

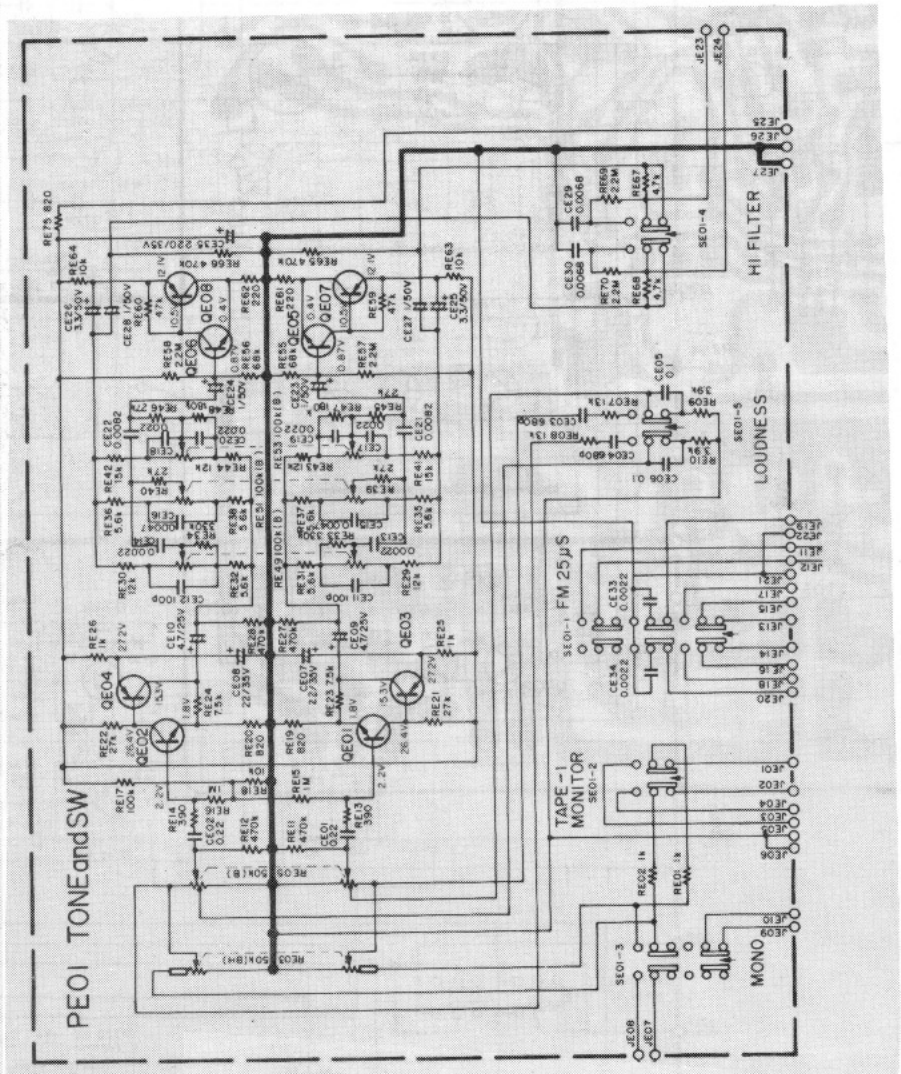
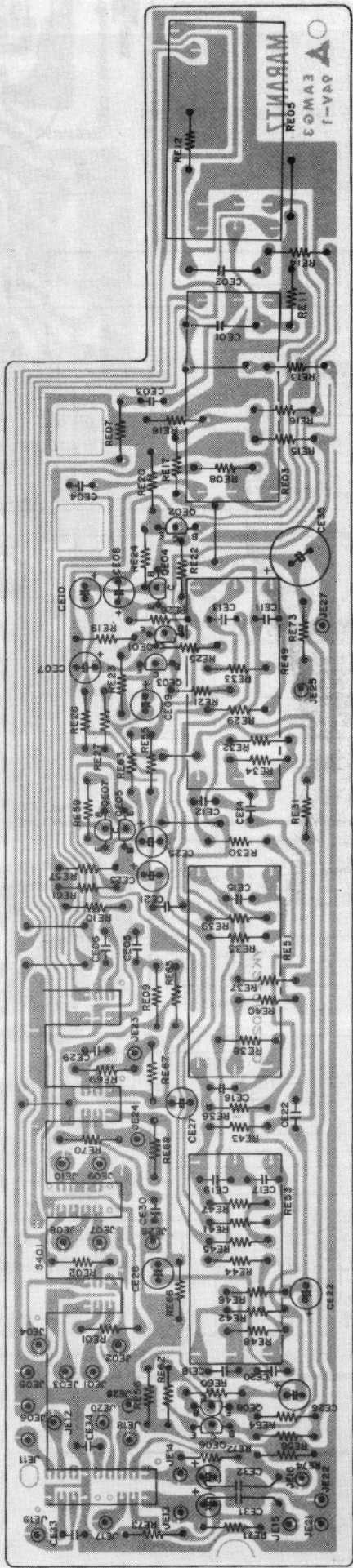

# 11.4 Main Amp. & Power Supply Assembly (P700) Schematic Diagram and Component Locations

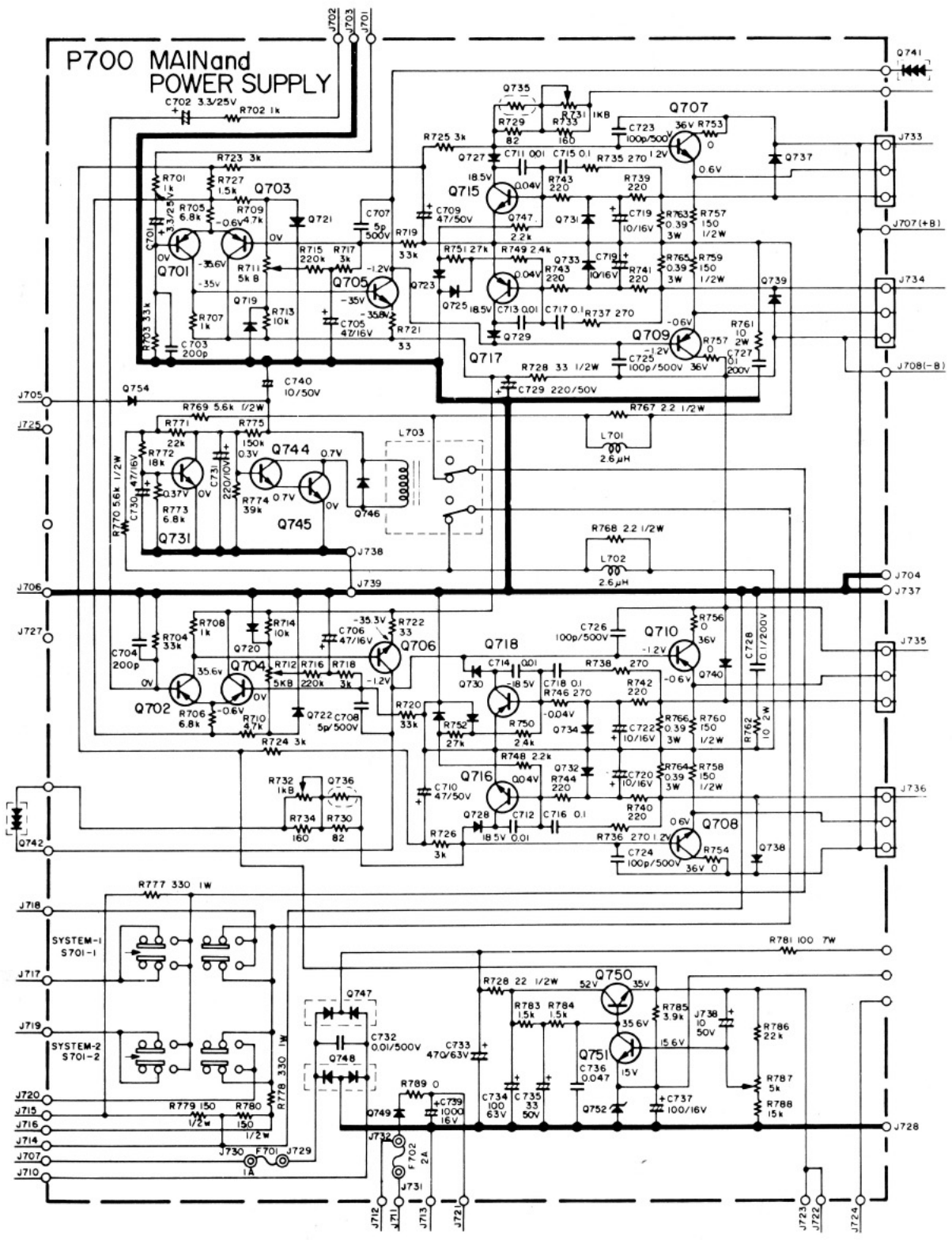

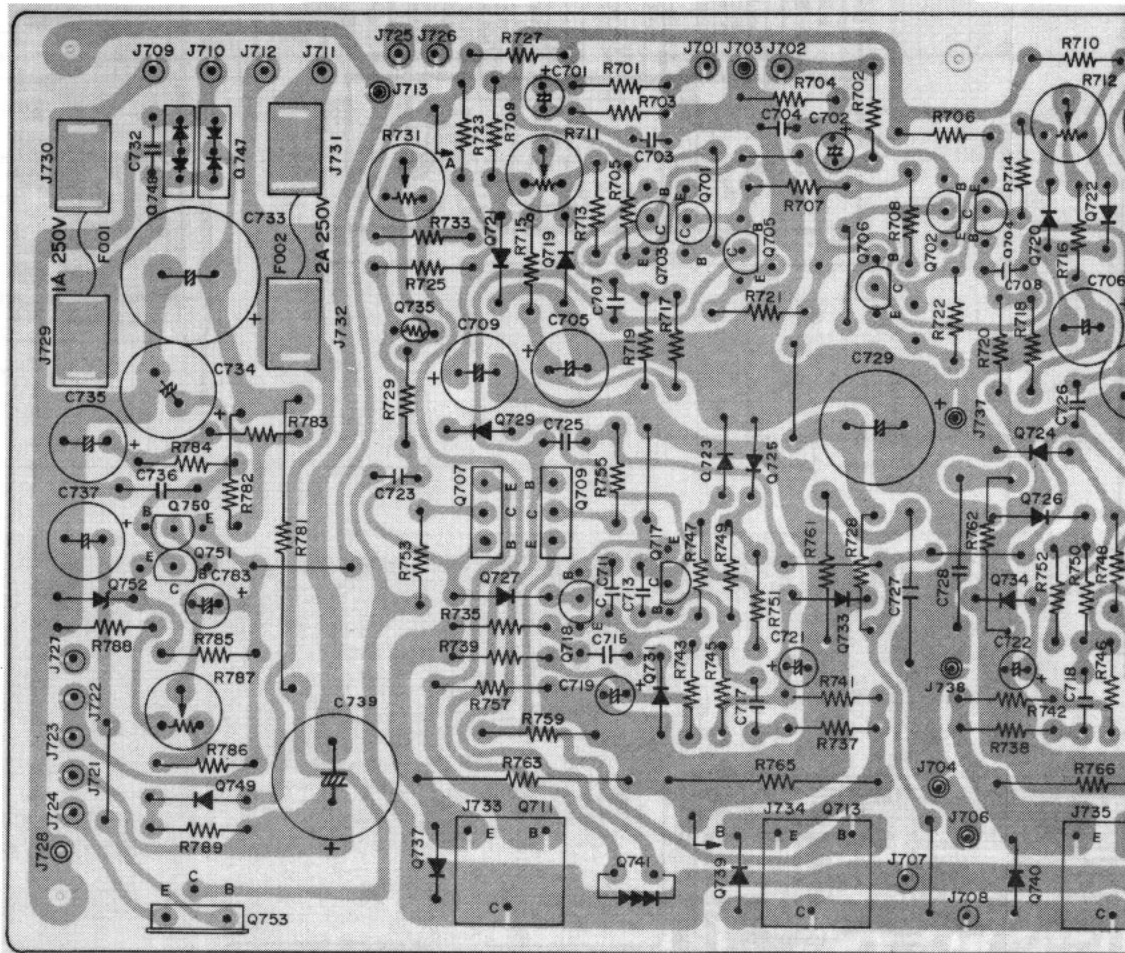

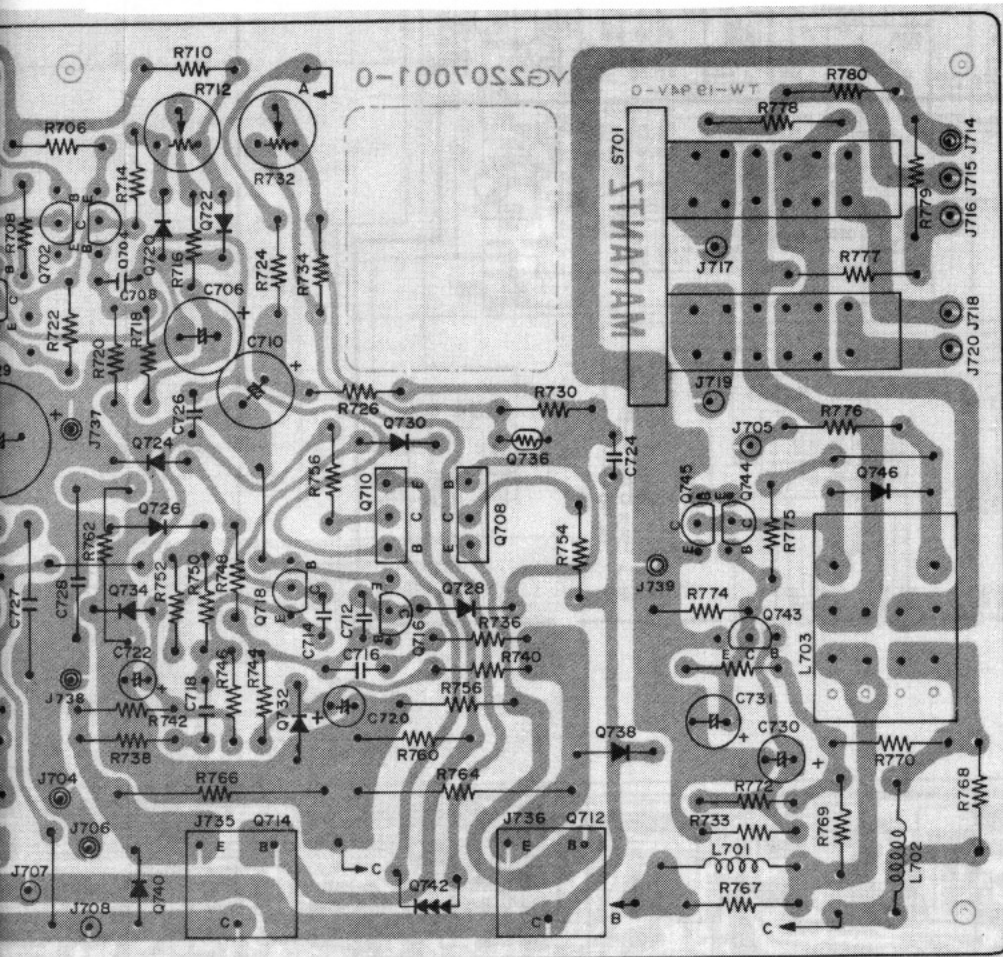



# Marantz 2238B

## DIAGRAM AND COMPONENT LOCATIONS

FM & AM Tuner Assembly (P200) Schematic Diagram and Component Locations

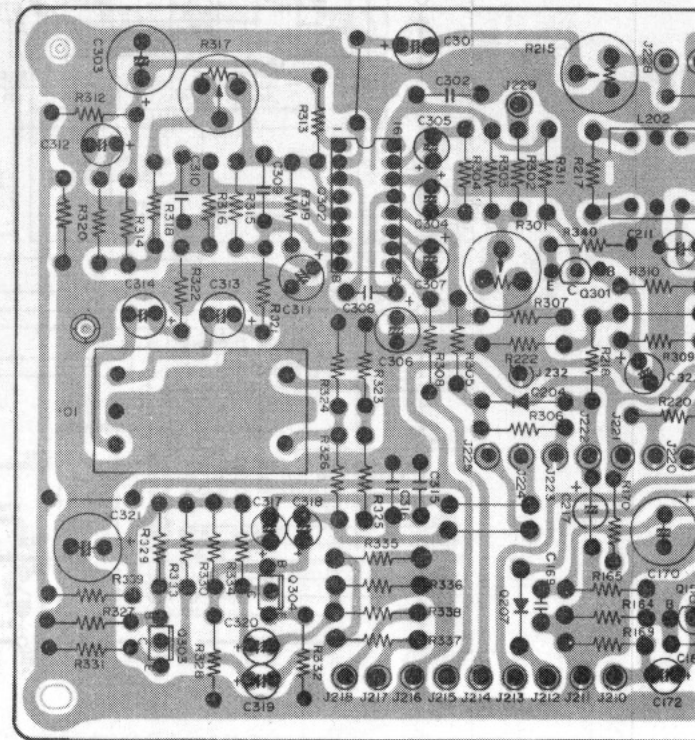
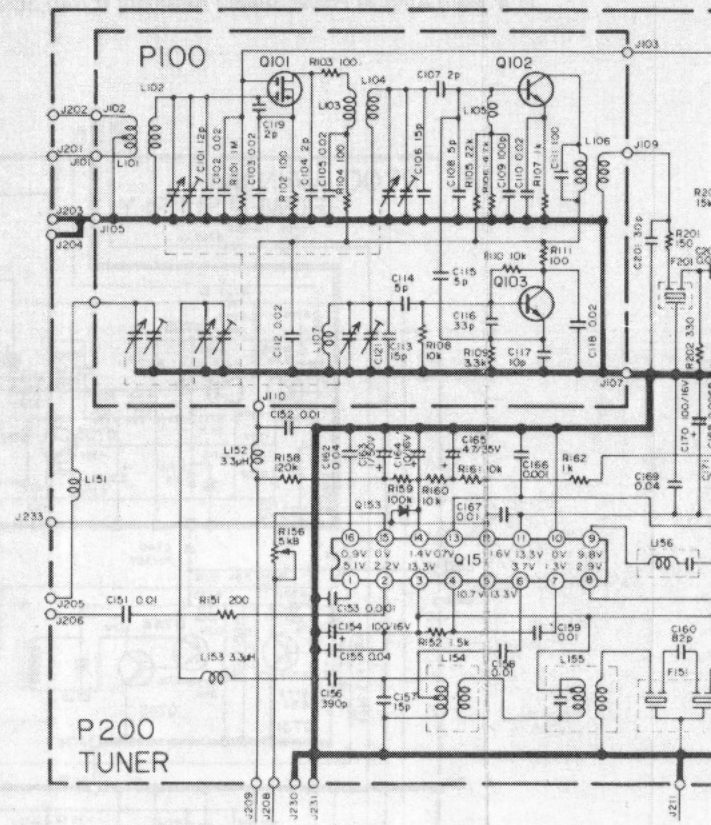

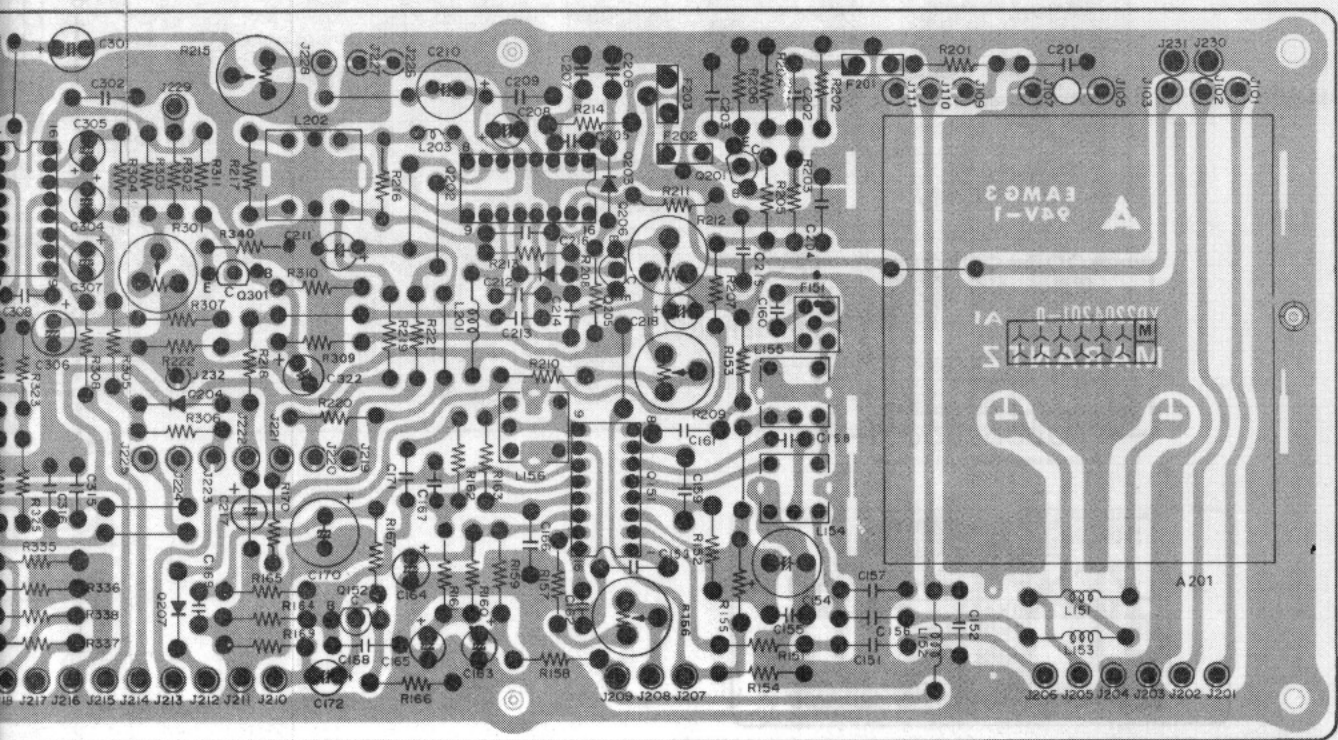
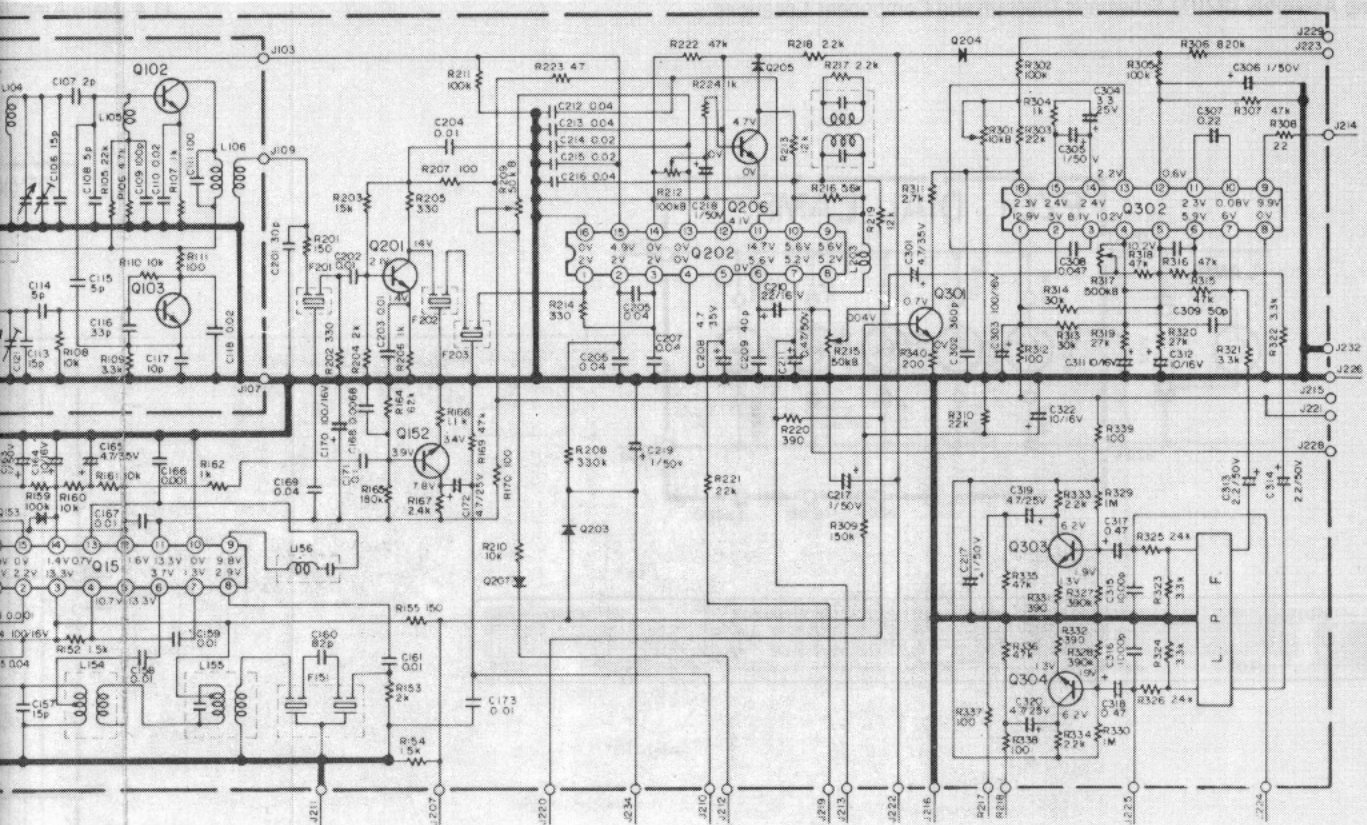

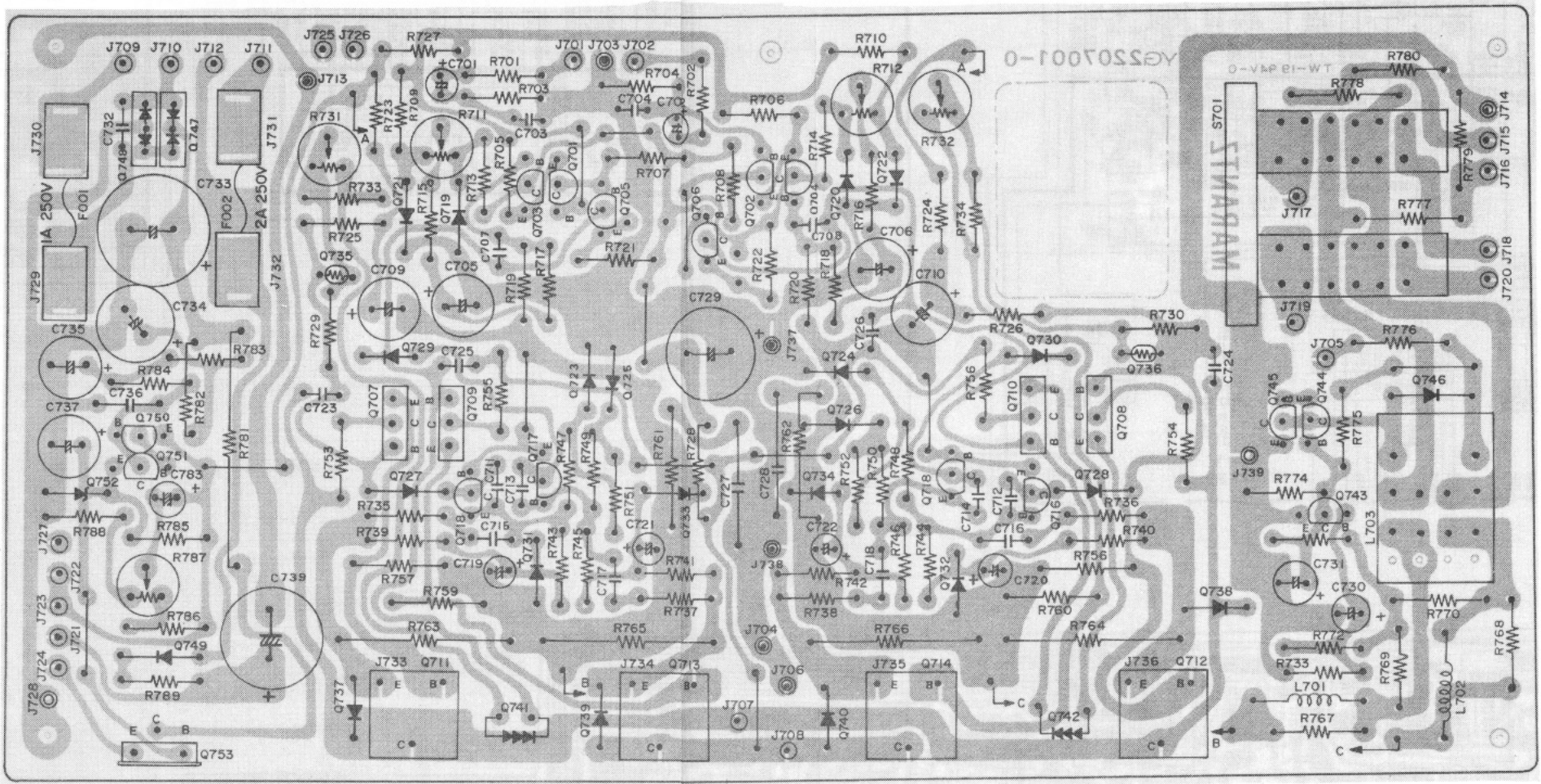
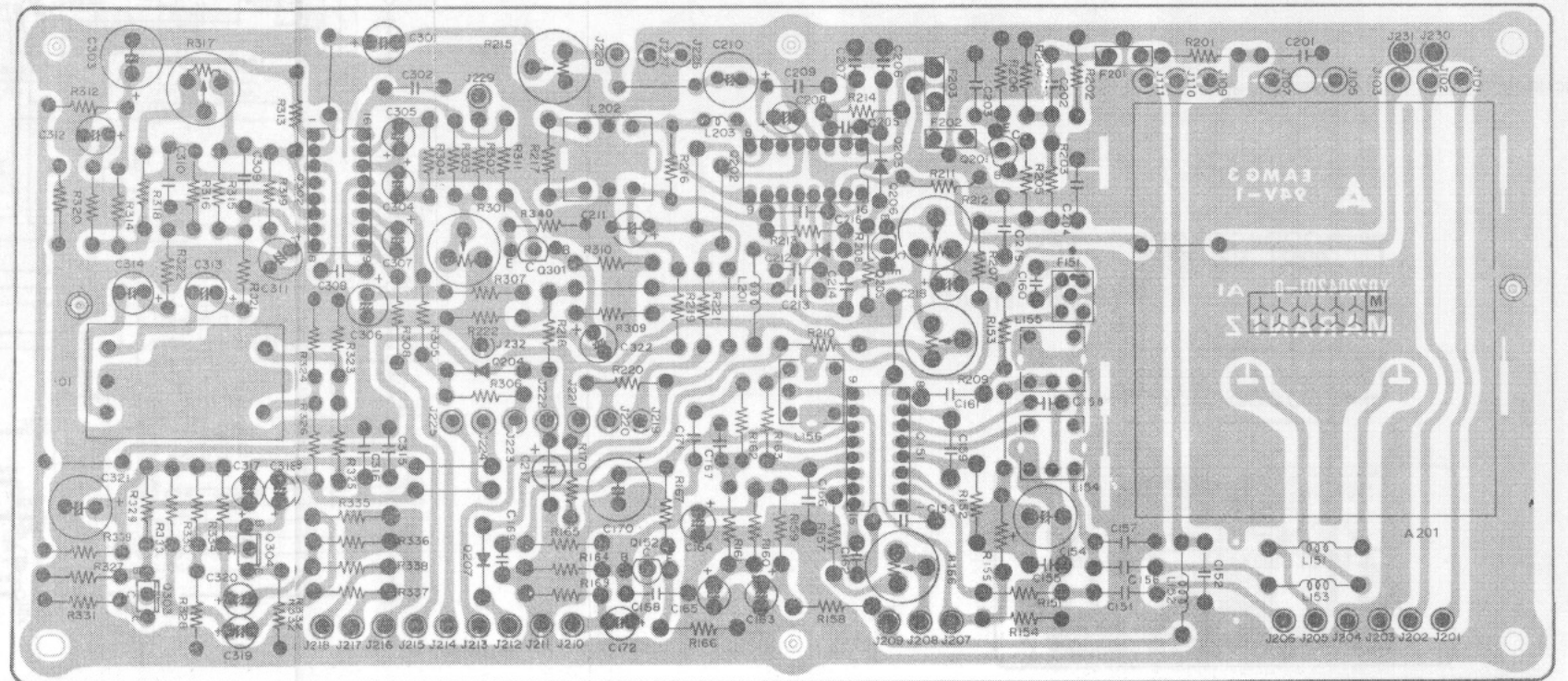
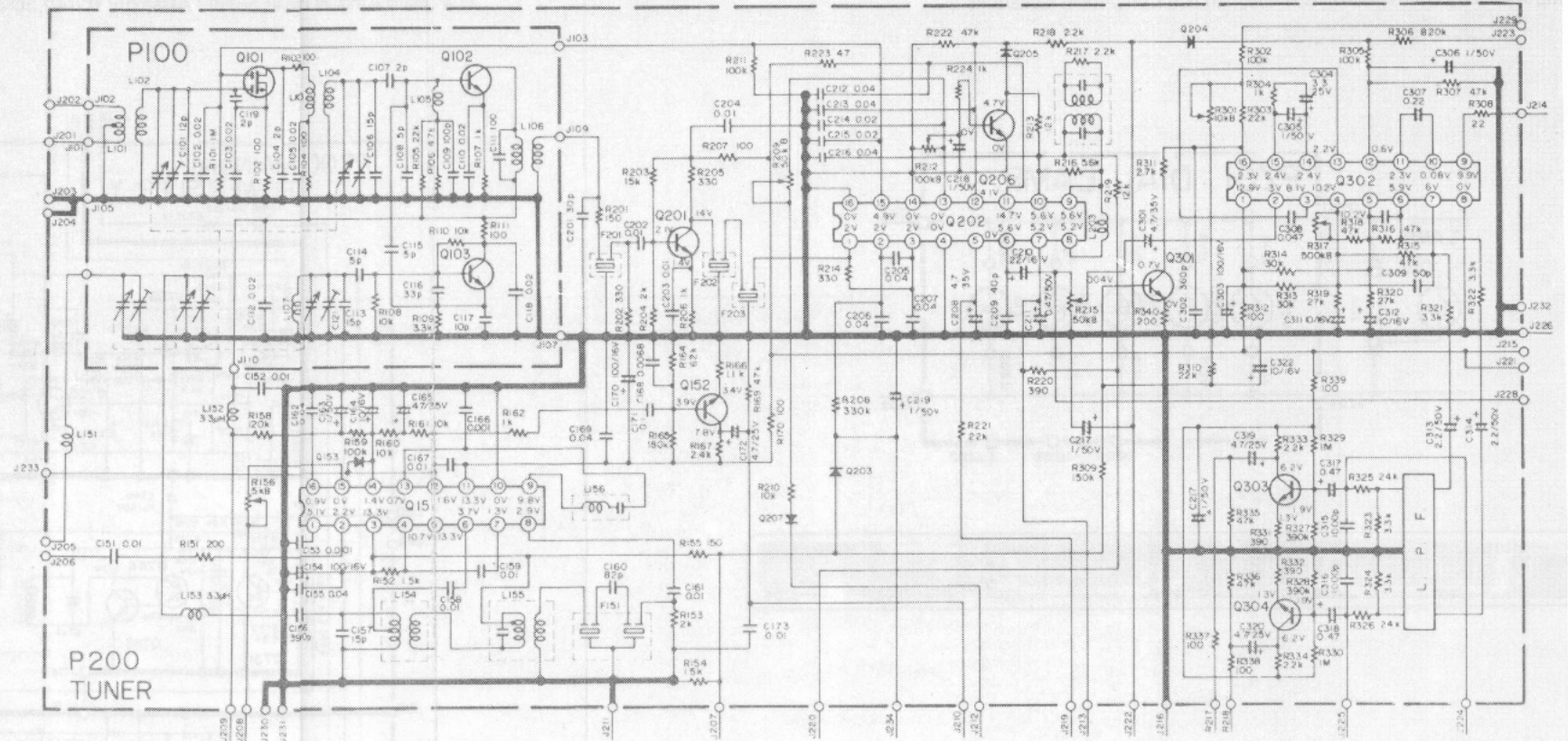
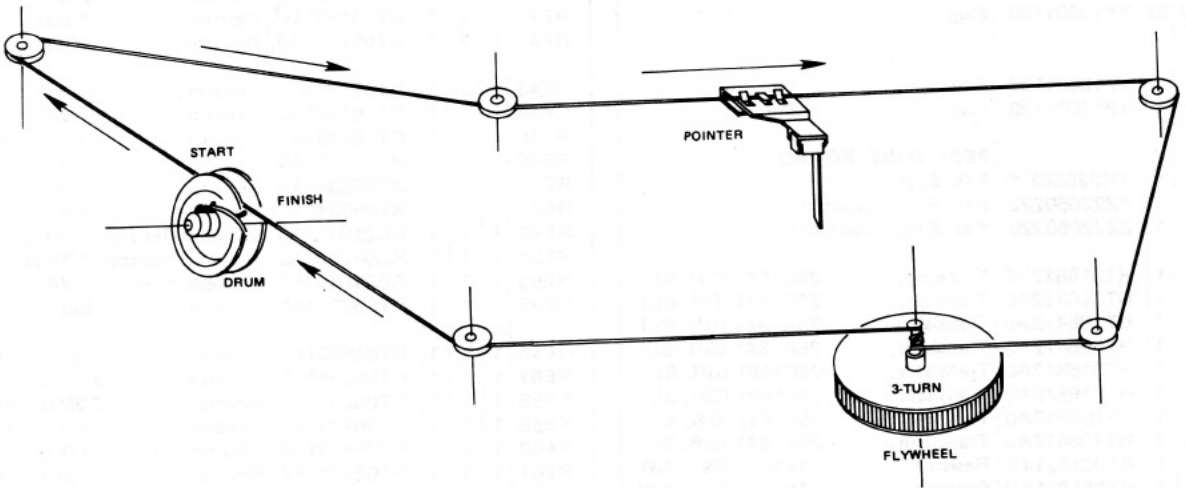
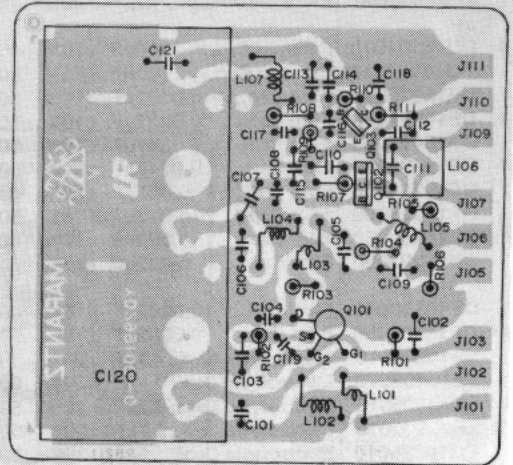
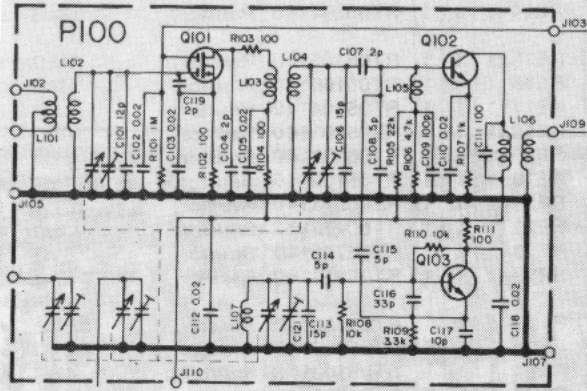

DIAGRAM AND COMPONENT LOCATIONS

FM & AM Tuner Assembly (P200) Schematic Diagram and Component Locations



FM Front End Assembly (P100) Schematic Diagram and Component Locations



REF. DESIG.	Q'TY			PART NO.	DESCRIPTION
	U	C	N		
CE01	1	1	1	DF17224050	Film Cap., 0.22μF ±20% 50V
CE02	1	1	1	DF17224050	Film Cap., 0.22μF ±20% 50V
CE03	1	1	1	DK16681010	Ceramic Cap., 680pF ±10% 50V
CE04	1	1	1	DK16681010	Ceramic Cap., 680pF ±10% 50V
CE05	1	1	1	DF16104010	Film Cap., 0.1μF ±10% 50V
CE06	1	1	1	DF16104010	Film Cap., 0.1μF ±10% 50V
CE07	1	1	1	EA10603590	Electrolytic Cap., 10μF ±10% 35V
CE08	1	1	1	EA10603590	Electrolytic Cap., 10μF ±10% 35V
CE09	1	1	1	EE47502540	Electrolytic Cap., 4.7μF ±20% 25V
CE10	1	1	1	EE47502540	Electrolytic Cap., 4.7μF ±20% 25V
CE11	1	1	1	DD16101010	Ceramic Cap., 100pF ±10% 50V
CE12	1	1	1	DD16101010	Ceramic Cap., 100pF ±10% 50V
CE13	1	1	1	DF16222050	Film Cap., 0.0022μF ±10% 50V
CE14	1	1	1	DF16222050	Film Cap., 0.0022μF ±10% 50V
CE15	1	1	1	DF16472050	Film Cap., 0.0047μF ±10% 50V
CE16	1	1	1	DF16472050	Film Cap., 0.0047μF ±10% 50V
CE17	1	1	1	DF16223050	Film Cap., 0.022μF ±10% 50V
CE18	1	1	1	DF16223050	Film Cap., 0.022μF ±10% 50V
CE19	1	1	1	DF16223050	Film Cap., 0.022μF ±10% 50V
CE20	1	1	1	DF16223050	Film Cap., 0.022μF ±10% 50V
CE21	1	1	1	DF16822050	Film Cap., 0.0082μF ±10% 50V
CE22	1	1	1	DF16822050	Film Cap., 0.0082μF ±10% 50V
CE23	1	1	1	EE10505010	Electrolytic Cap., 1μF ±20% 50V
CE24	1	1	1	EE10505010	Electrolytic Cap., 1μF ±20% 50V
CE25	1	1	1	EE33505010	Electrolytic Cap., 3.3μF ±20% 50V
CE26	1	1	1	EE33505010	Electrolytic Cap., 3.3μF ±20% 50V
CE27	1	1	1	EQ10505010	Electrolytic Cap., 1μF ±30% 50V
CE27	1	1	1	EQ10603510	Electrolytic Cap., 10μF ±30% 35V
CE28	1	1	1	EQ10505010	Electrolytic Cap., 1μF ±30% 50V
CE28	1	1	1	EQ10603510	Electrolytic Cap., 10μF ±30% 35V
CE29	1	1	1	DF16682050	Film Cap., 0.0068μF ±10% 50V
CE30	1	1	1	DF16682050	Film Cap., 0.0068μF ±10% 50V
CE31	1	1	1	EQ22405010	Electrolytic Cap., 0.22μF ±30% 50V
CE32	1	1	1	EQ22405010	Electrolytic Cap., 0.22μF ±30% 50V
CE33	1	1	1	DF15222050	Film Cap., 0.0022μF ±5% 50V
CE34	1	1	1	DF15222050	Film Cap., 0.0022μF ±5% 50V
CE35	1	1	1	EA22703590	Electrolytic Cap., 220μF ±10% 35V
JE01	27	27	27	YP10001130	Plug
JE27					
JE28	1	1	1	YP10001130	Plug, Pin
JE29	1	1	1	YP10001130	Plug, Pin
<b>PE01 TONE BOARD</b>					
PE01	1	1	1	YK22050220	P.W. Board
	1	1	1	ZZ22050220	P.W. Board Assembly
			1	ZZ22058220	P.W. Board Assembly
QE01	1	1	1	HT316812A0	Transistor, 2SC1681 (GR, BL)
QE02	1	1	1	HT316812A0	Transistor, 2SC1681 (GR, BL)
QE03	1	1	1	HT108412A0	Transistor, 2SA 841 (GR, BL)
QE04	1	1	1	HT108412A0	Transistor, 2SA 841 (GR, BL)
QE05	1	1	1	HT316812A0	Transistor, 2SC1681 (GR, BL)
QE06	1	1	1	HT316812A0	Transistor, 2SC1681 (GR, BL)
QE07	1	1	1	HT108412A0	Transistor, 2SA 841 (GR, BL)
QE08	1	1	1	HT108412A0	Transistor, 2SA 841 (GR, BL)
RE01	1	1	1	RT05102140	Resistor, 1kΩ ±5% ¼W
RE02	1	1	1	RT05102140	Resistor, 1kΩ ±5% ¼W

REF. DESIG.	Q'TY			PART NO.	DESCRIPTION
	U	C	N		
RE03	1	1	1	RM05030690	Variable Resistor, 50kΩ (BH) Balance
RE05	1	1	1	RM05030700	Variable Resistor, 50kΩ (B) Volume
RE07	1	1	1	RT05133140	Resistor, 13kΩ ±5% ¼W
RE08	1	1	1	RT05133140	Resistor, 13kΩ ±5% ¼W
RE09	1	1	1	RT05392140	Resistor, 3.9kΩ ±5% ¼W
RE10	1	1	1	RT05392140	Resistor, 3.9kΩ ±5% ¼W
RE11	1	1	1	RT05474140	Resistor, 470kΩ ±5% ¼W
RE12	1	1	1	RT05474140	Resistor, 470kΩ ±5% ¼W
RE13	1	1	1	RT05391140	Resistor, 390Ω ±5% ¼W
RE14	1	1	1	RT05391140	Resistor, 390Ω ±5% ¼W
RE15	1	1	1	RT05105140	Resistor, 1MΩ ±5% ¼W
RE16	1	1	1	RT05105140	Resistor, 1MΩ ±5% ¼W
RE17	1	1	1	RT05104140	Resistor, 100kΩ ±5% ¼W
RE18	1	1	1	RT05103140	Resistor, 10kΩ ±5% ¼W
RE19	1	1	1	RT05102140	Resistor, 1kΩ ±5% ¼W
RE20	1	1	1	RT05102140	Resistor, 1kΩ ±5% ¼W
RE21	1	1	1	RT05273140	Resistor, 27kΩ ±5% ¼W
RE22	1	1	1	RT05273140	Resistor, 27kΩ ±5% ¼W
RE23	1	1	1	RT05752140	Resistor, 7.5kΩ ±5% ¼W
RE23	1	1	1	RT05822140	Resistor, 8.2kΩ ±5% ¼W
RE24	1	1	1	RT05752140	Resistor, 7.5kΩ ±5% ¼W
RE24	1	1	1	RT05822140	Resistor, 8.2kΩ ±5% ¼W
RE25	1	1	1	RT05102140	Resistor, 1kΩ ±5% ¼W
RE26	1	1	1	RT05102140	Resistor, 1kΩ ±5% ¼W
RE27	1	1	1	RT05474140	Resistor, 470kΩ ±5% ¼W
RE27	1	1	1	RT05474140	Resistor, 470kΩ ±5% ¼W
RE28	1	1	1	RT05474140	Resistor, 470kΩ ±5% ¼W
RE29	1	1	1	RT05123140	Resistor, 12kΩ ±5% ¼W
RE30	1	1	1	RT05123140	Resistor, 12kΩ ±5% ¼W
RE31	1	1	1	RT05562140	Resistor, 5.6kΩ ±5% ¼W
RE32	1	1	1	RT05562140	Resistor, 5.6kΩ ±5% ¼W
RE33	1	1	1	RT05334140	Resistor, 330kΩ ±5% ¼W
RE34	1	1	1	RT05334140	Resistor, 330kΩ ±5% ¼W
RE35	1	1	1	RT05562140	Resistor, 5.6kΩ ±5% ¼W
RE36	1	1	1	RT05562140	Resistor, 5.6kΩ ±5% ¼W
RE37	1	1	1	RT05562140	Resistor, 5.6kΩ ±5% ¼W
RE38	1	1	1	RT05562140	Resistor, 5.6kΩ ±5% ¼W
RE39	1	1	1	RT05273140	Resistor, 27kΩ ±5% ¼W
RE40	1	1	1	RT05273140	Resistor, 27kΩ ±5% ¼W
RE41	1	1	1	RT05153140	Resistor, 15kΩ ±5% ¼W
RE42	1	1	1	RT05153140	Resistor, 15kΩ ±5% ¼W
RE43	1	1	1	RT05123140	Resistor, 12kΩ ±5% ¼W
RE44	1	1	1	RT05123140	Resistor, 12kΩ ±5% ¼W
RE45	1	1	1	RT05273140	Resistor, 27kΩ ±5% ¼W
RE46	1	1	1	RT05273140	Resistor, 27kΩ ±5% ¼W
RE47	1	1	1	RT05334140	Resistor, 330kΩ ±5% ¼W
RE48	1	1	1	RT05334140	Resistor, 330kΩ ±5% ¼W
RE49	1	1	1	RD01040150	Variable Resistor, 100kΩ (B) Treble
RE51	1	1	1	RD01040150	Variable Resistor, 100kΩ (B) Mid
RE53	1	1	1	RD01040150	Variable Resistor, 100kΩ (B) Bass
RE55	1	1	1	RT05683140	Resistor, 68kΩ ±5% ¼W
RE56	1	1	1	RT05683140	Resistor, 68kΩ ±5% ¼W
RE57	1	1	1	RT05225140	Resistor, 2.2MΩ ±5% ¼W
RE58	1	1	1	RT05225140	Resistor, 2.2MΩ ±5% ¼W
RE59	1	1	1	RT05473140	Resistor, 47kΩ ±5% ¼W
RE60	1	1	1	RT05473140	Resistor, 47kΩ ±5% ¼W
RE61	1	1	1	RT05221140	Resistor, 220Ω ±5% ¼W
RE62	1	1	1	RT05221140	Resistor, 220Ω ±5% ¼W

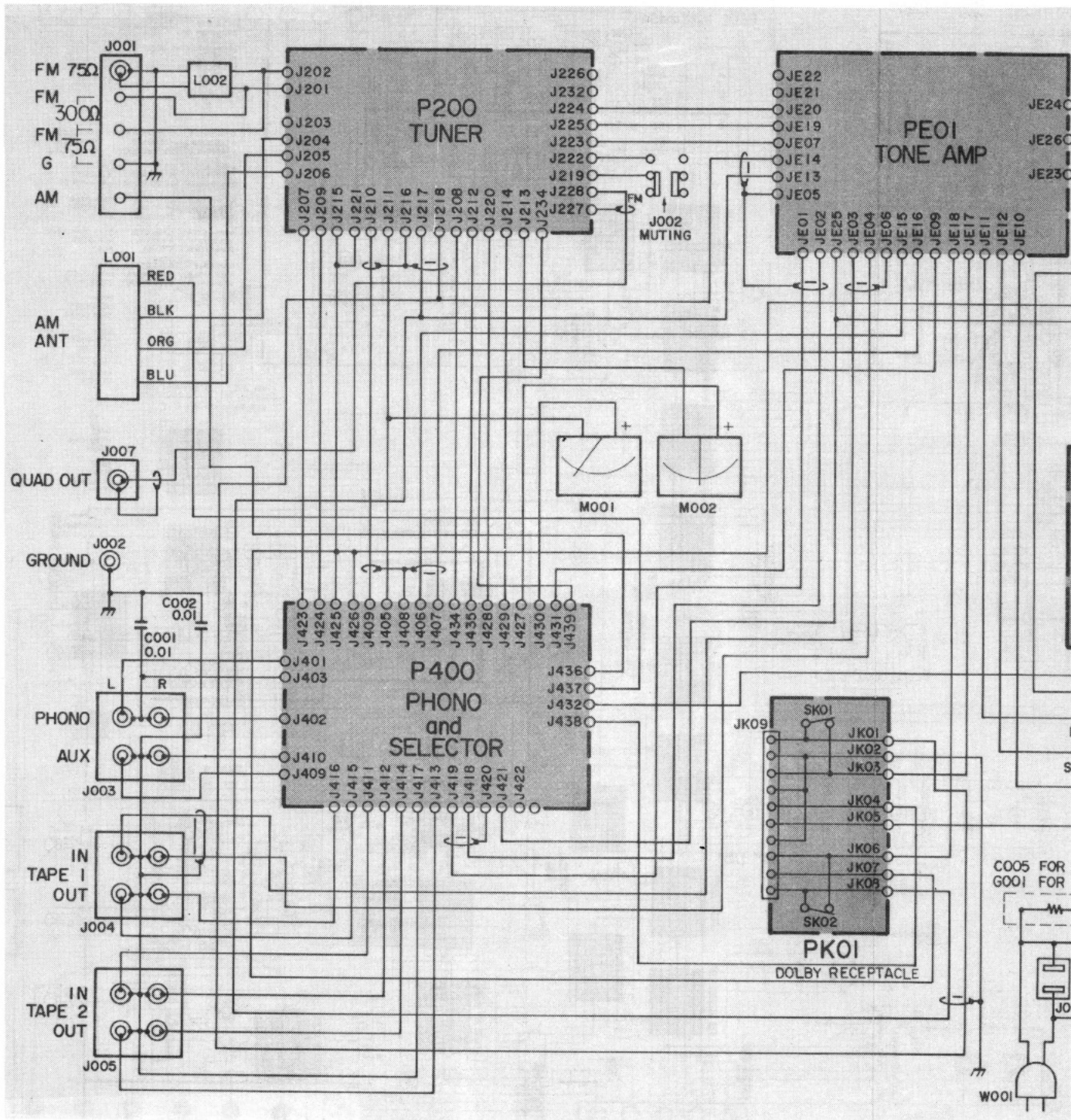

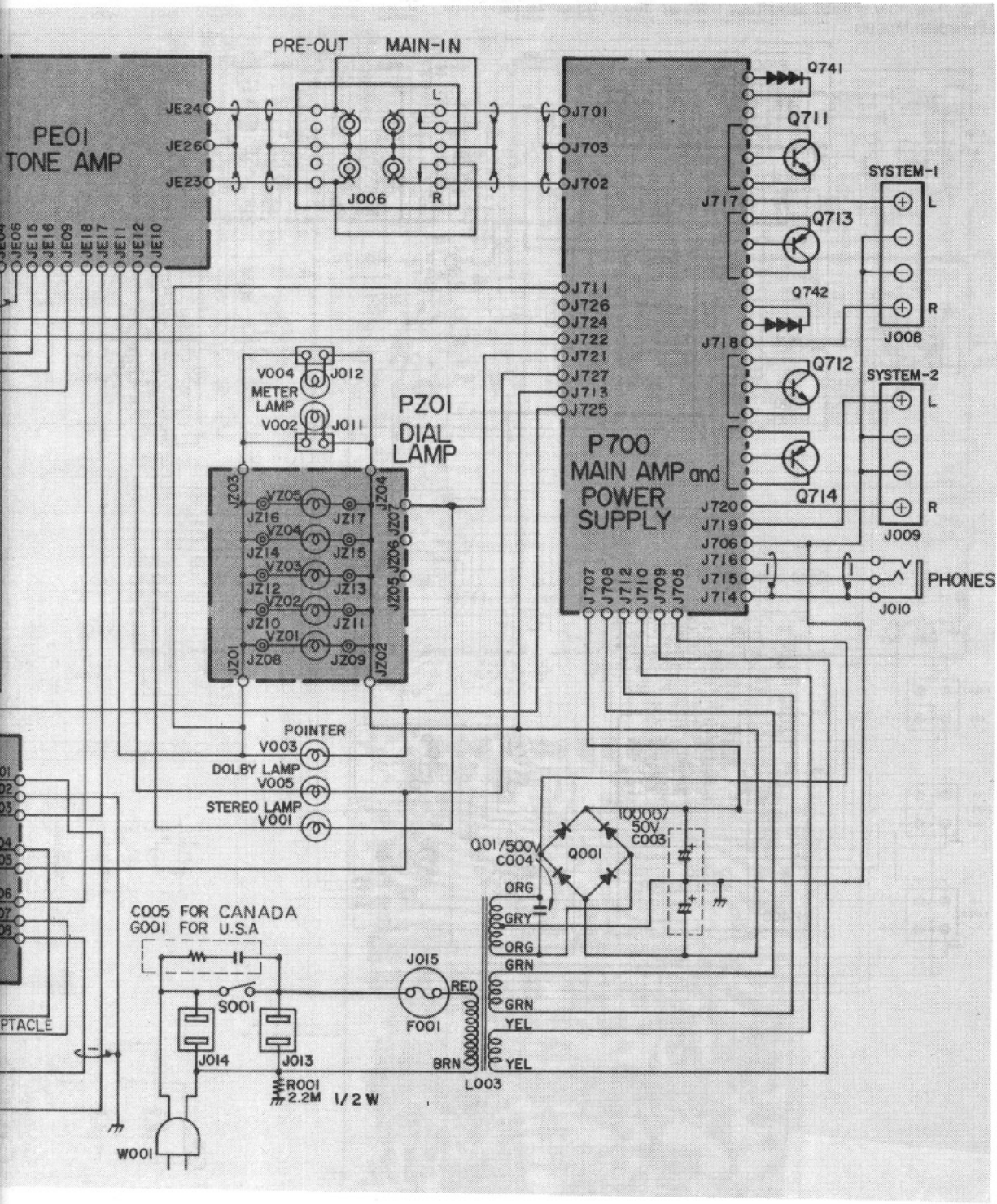



For U.S.A. & Canadian Models

- |                             |                                       |                             |                                 |                              |  |                                 |                             |                                       |                                 |                             |                             |                              |
|-----------------------------|---------------------------------------|-----------------------------|---------------------------------|------------------------------|--|---------------------------------|-----------------------------|---------------------------------------|---------------------------------|-----------------------------|-----------------------------|------------------------------|
| Q151<br>HC1001901<br>HA1197 | Q152<br>HT313272A<br>25C1327(19 or T) | Q153<br>HY0000612<br>MV-203 | Q201<br>HT310471C<br>25C1047(C) | Q202<br>HC1002101<br>HA1137W | Q203-Q205, Q207, Q407<br>HD2000121<br>152473 | Q301<br>HT3082810<br>25C828(15) | Q302<br>HC0002001<br>HA1196 | Q303, Q304<br>HT313441E<br>25C1344(E) | Q206<br>HT3682810<br>25C828(15) | Q101<br>HF400451B<br>25K45B | Q102<br>HT305352B<br>25C535 | Q103<br>HT313422B<br>25C1342 |
|-----------------------------|---------------------------------------|-----------------------------|---------------------------------|------------------------------|--|---------------------------------|-----------------------------|---------------------------------------|---------------------------------|-----------------------------|-----------------------------|------------------------------|

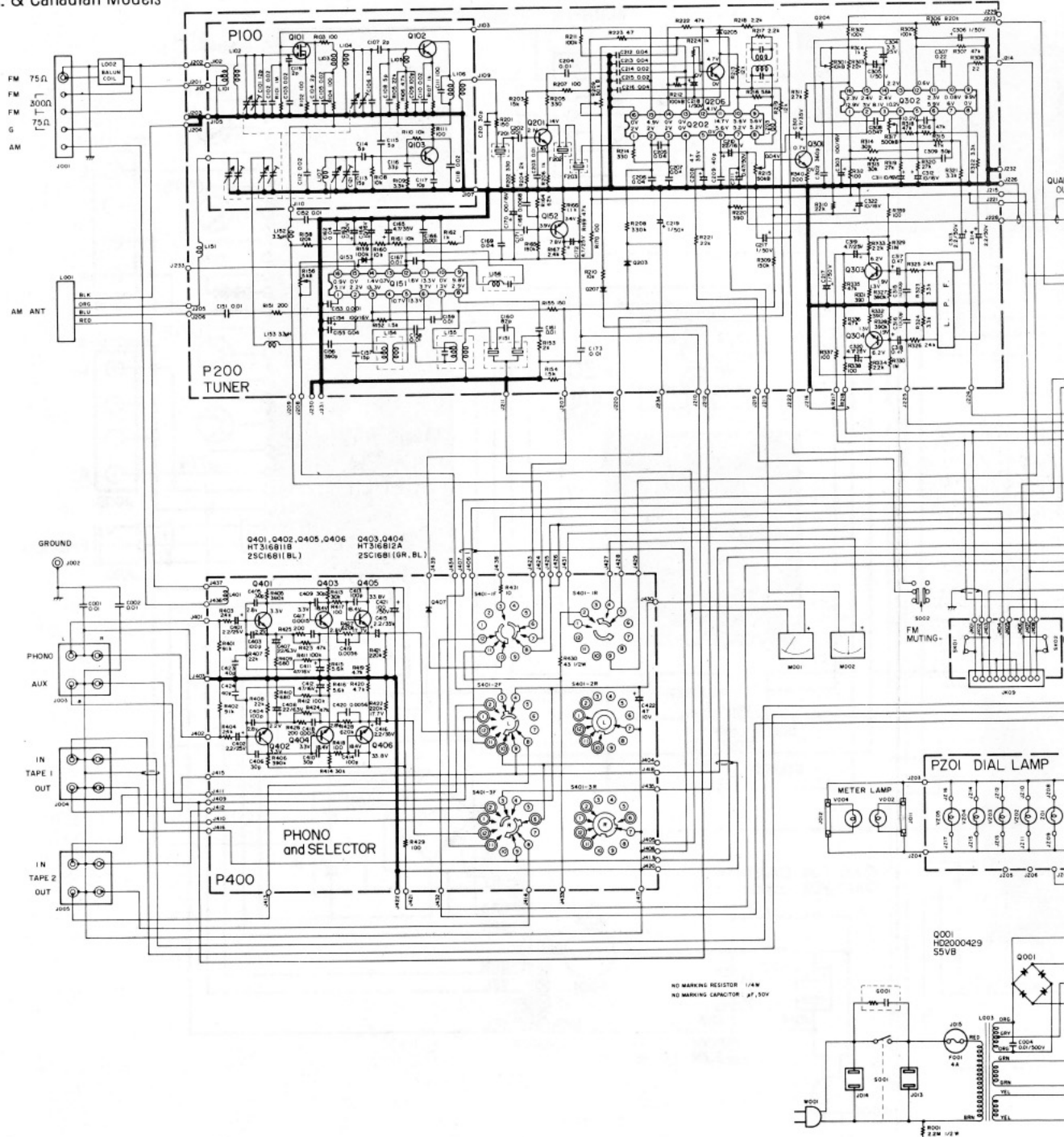

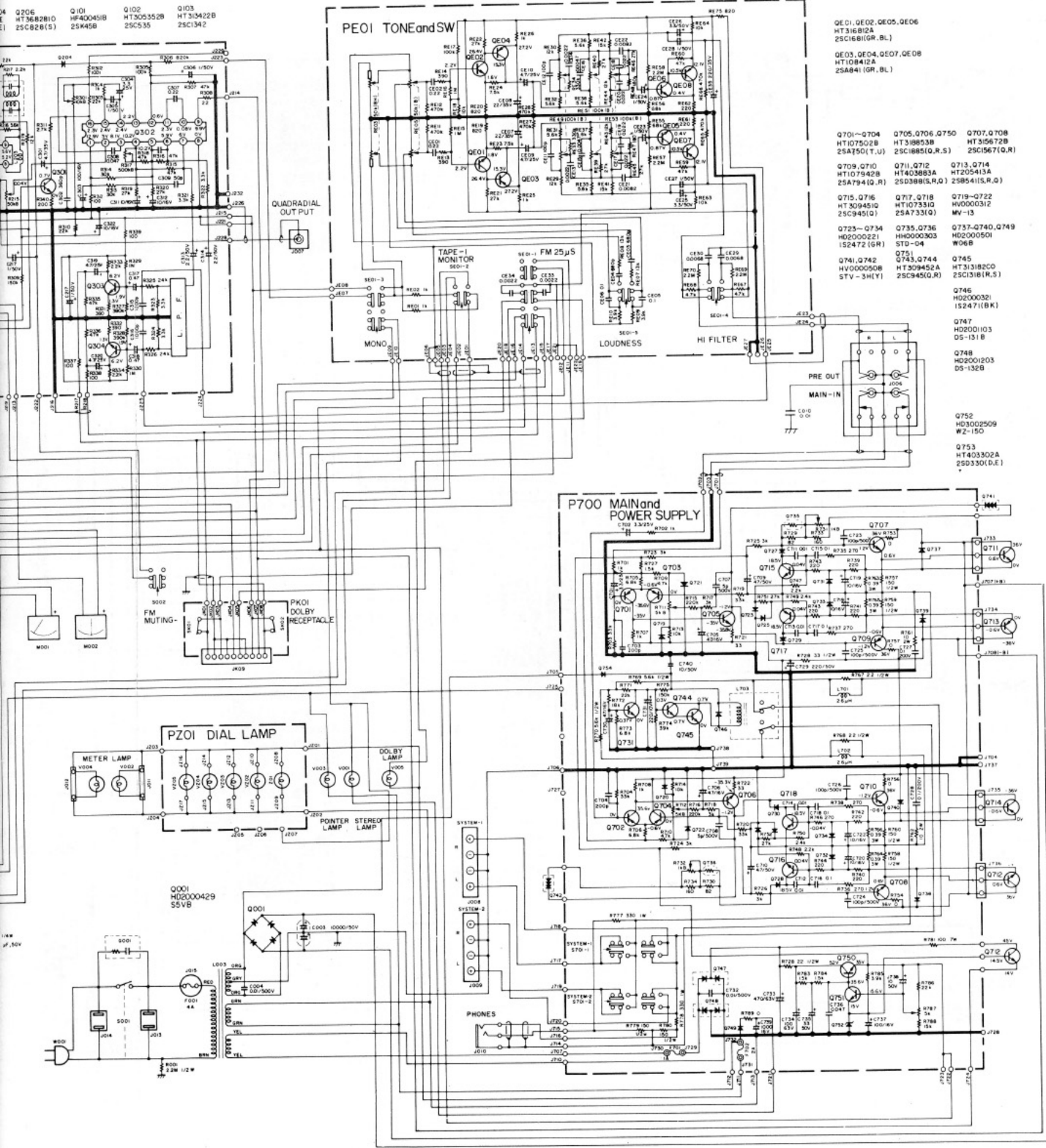

- QEO1, QEO2, QEO3, QEO6  
HT316802A  
25C161(GR, BL)
- QEO3, QEO4, QEO7, QEO9  
HT108412A  
25A841(GR, BL)
- Q701-Q704 HT107502B HT319853B  
25A7501(U, J) 25C1885(O, R, S) 25C167(Q, R)
- Q709, Q710 HT107942B HT403883A  
25A794(Q, R) 25D389(O, R, D) 25B541(S, R, D)
- Q715, Q716 HT309451D HT107331Q  
25C945(O, D) 25A733(O, Q)
- Q717, Q718 HT309452A HT107331Q  
25C945(O, R) 25A733(O, Q)
- Q719-Q722 HV0000312 HV0000312  
MV-13
- Q723-Q734 HD2000221 HV0000303  
152472(GR) ST0-04 W06B
- Q741, Q742 HV000050B HT309452A  
STV-3H(U, T) 25C945(O, R)
- Q745 HT313182C  
25C1318(I, S)
- Q746 HD2000321  
152471(BK)
- Q747 HD2001103  
DS-131B
- Q748 HD2001203  
DS-132B
- Q752 HD3002509  
WZ-150
- Q753 HT403302A  
25D330(D, E)

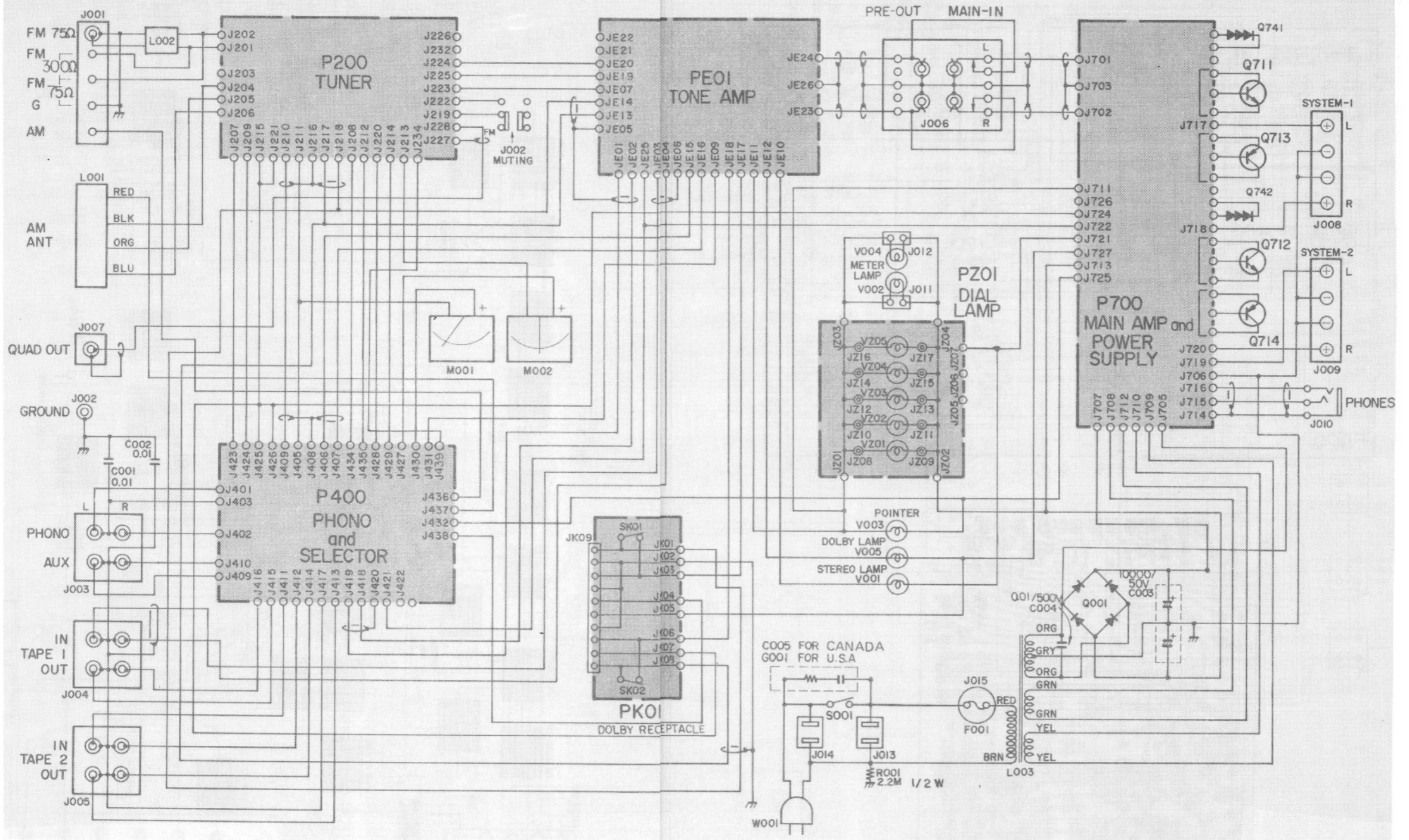



• (U) for U.S.A.  
• (C) for Canada  
• (N) for Europe

REF. DESIG.	QTY			PART NO.	DESCRIPTION
	U	C	N		
RE63	1	1	1	RT05103140	Resistor, 10kΩ ±5% ¼W
RE64	1	1	1	RT05103140	Resistor, 10kΩ ±5% ¼W
RE65	1	1	1	RT05474140	Resistor, 470kΩ ±5% ¼W
RE66	1	1	1	RT05474140	Resistor, 470kΩ ±5% ¼W
RE67	1	1	1	RT05472140	Resistor, 4.7kΩ ±5% ¼W
RE68	1	1	1	RT05472140	Resistor, 4.7kΩ ±5% ¼W
RE69	1	1	1	RT05225140	Resistor, 2.2MΩ ±5% ¼W
RE70	1	1	1	RT05225140	Resistor, 2.2MΩ ±5% ¼W
RE71	1	1	1	RT05105140	Resistor, 1MΩ ±5% ¼W
RE72	1	1	1	RT05105140	Resistor, 1MΩ ±5% ¼W
RE73			1	RT05562140	Resistor, 5.6kΩ ±5% ¼W
RE74			1	RT05562140	Resistor, 5.6kΩ ±5% ¼W
RE75	1	1	1	RT05821140	Resistor, 820Ω ±5% ¼W
SE01	1	1	1	SP06050110	Pushswitch, Dolby, Tape, etc.
JK01					
JK08	8	8		YP10001130	Plug
JK09	1	1		YJ07000120	Jack
PK01	1	1		YA22180310	<b>PK01 DOLBY SOCKET BOARD</b> P.W. Board
	1	1		ZZ22180310	P.W. Board Assembly
SK01	1	1		SC01020240	Switch, Micro Switch
SK02	1	1		SC01020240	Switch, Micro Switch
JZ01					
JZ07	7	7	7	YP10001130	Plug
JZ08					
JZ17	10	10	10	YJ08000170	Jack, 10P PC Connector
PZ01	1	1	1	YF22130050	<b>PZ01 DIAL LAMP BOARD</b> P.W. Board
	1	1	1	ZZ22130050	P.W. Board Assembly
VZ01	1	1	1	IN10080070	Lamp, 8V 200mA
VZ02	1	1	1	IN10080070	Lamp, 8V 200mA
VZ03	1	1	1	IN10080070	Lamp, 8V 200mA
VZ04	1	1	1	IN10080070	Lamp, 8V 200mA
VZ05	1	1	1	IN10080070	Lamp, 8V 200mA
C001	1	1	1	DK18103010	Ceramic Cap., 0.01μF ±10% 50V
C002	1	1	1	DK18103010	Ceramic Cap., 0.01μF ±10% 50V
C003	1	1	1	EI10905010	Electrolytic Cap., 10000μF ±10% 50V
C004	1	1	1	DK18103510	Ceramic Cap., 0.01μF 500V
C005	1	1	1	BF10400050	Cap. Comp., Printed Comp.
C005	1	1	1	DC07223510	Oil-Paper Cap., 0.022μF ±10% 450V
C006	1	1	1	DF17223800	Film Cap., 0.02μF 1000V
F001	1	1	1	FS10250800	Fuse, 2.5A SEMKO Type 20mm
F001	1	1	1	FS10400050	Fuse, 4A MGC 30mm
F002	1	1	1	FS20500910	Fuse, 5A MGP 30mm
G001	1	1	1	BF10400030	Cap. Comp., Printed Comp.
J001	1	1	1	BY04050010	Terminal, Ant. Terminal
J002	1	1	1	YT01010050	Terminal, Ground Terminal
J003	1	1	1	YT02040140	Terminal, Phono, Aux
J004	1	1	1	YT02040140	Terminal, Tape 1 In, Out
J005	1	1	1	YT02040140	Terminal, Tape 2 In, Out
J006	1	1	1	YT02040170	Terminal, Pre Out, Main In
J007	1	1	1	YT02010130	Terminal, Quad. Out

REF. DESIG.	QTY			PART NO.	DESCRIPTION
	U	C	N		
J008	1	1	1	YT03040160	Terminal, Spkr Terminal (System 1)
J009	1	1	1	YT03040160	Terminal, Spkr Terminal (System 2)
J010	1	1	1	YJ01001080	Jack
J011	1	1	1	YJ08000250	Jack, Lamp Socket
J012	1	1	1	YJ08000250	Jack, Lamp Socket
J013	1	1	1	YJ04000560	Jack, AC Outlet
J014	1	1	1	YJ04000560	Jack, AC Outlet
J015	1	1	1	BY03110010	Plug, Voltage Selector
J015	1	1	1	YJ08000120	Jack, Fuse Holder
J016	1	1	1	YL09030010	Terminal
J017	1	1	1	YJ08000220	Jack, Fuse Holder
L001	1	1	1	LF11200520	Ant. Coil, AM Rod Ant.
L002	1	1	1	LB30075260	Balun Coil
L003	1	1	1	TS19609010	Power Transformer
L003	1	1	1	TS19609020	Power Transformer
M001	1	1	1	IM11055080	DC Meter, Signal
M002	1	1	1	IM11055050	DC Meter, Tuning
Q001	1	1	1	HD20004290	Diode, S5VB
R001	1	1	1	RC10225120	Resistor, 2.2MΩ ±10% ½W
S001	1	1	1	SP02010280	Pushswitch, Power (U)
S001	1	1	1	SP04010250	Pushswitch, Power
S002	1	1	1	SP02010260	Pushswitch, Muting
V001	1	1	1	IN10080340	Lamp, Stereo
V002	1	1	1	IN10080430	Lamp, 8V 0.3A
V004	1	1	1	IN10080430	Lamp, 8V 0.3A
V005	1	1	1	IN10080340	Lamp, Dolby
W001	1	1	1	YC01900030	AC Power Cord
W001	1	1	1	YC02400220	AC Power Cord
C101	1	1	1	DD16120020	Ceramic Cap., 12pF ±10%
C102	1	1	1	DK18203030	Ceramic Cap., 0.02μF
C103	1	1	1	DK18203030	Ceramic Cap., 0.02μF
C104	1	1	1	DD11020010	Ceramic Cap., 2pF
C105	1	1	1	DK18203030	Ceramic Cap., 0.02μF
C106	1	1	1	DD16150040	Ceramic Cap., 15pF ±10%
C107	1	1	1	DD11020010	Ceramic Cap., 2pF
C108	1	1	1	DD12050010	Ceramic Cap., 5pF
C109	1	1	1	DD16101010	Ceramic Cap., 100pF ±10%
C110	1	1	1	DK18203030	Ceramic Cap., 0.02μF
C111	1	1	1	DD16101010	Ceramic Cap., 100pF ±10%
C112	1	1	1	DK18203030	Ceramic Cap., 0.02μF
C113	1	1	1	DD15150020	Ceramic Cap., 15pF ±5%
C114	1	1	1	DD10050030	Ceramic Cap., 5pF
C115	1	1	1	DD12050010	Ceramic Cap., 5pF
C116	1	1	1	DD16330020	Ceramic Cap., 33pF ±10%
C117	1	1	1	DD12100060	Ceramic Cap., 10pF
C118	1	1	1	DK18203030	Ceramic Cap., 0.02μF
C119	1	1	1	DD11020010	Ceramic Cap., 2pF
C120	1	1	1	CA32400080	Variable Cap.
C121	1	1	1	CT14200010	Trimming Cap.
C151	1	1	1	DK17103010	Ceramic Cap., 0.01μF ±20%
C152	1	1	1	DK17103010	Ceramic Cap., 0.01μF ±20%
C153	1	1	1	DK17102010	Ceramic Cap., 0.001μF ±20%
C154	1	1	1	EA10701690	Electrolytic Cap., 100μF 16V
C155	1	1	1	DK18403020	Ceramic Cap., 0.04μF
C156	1	1	1	DF65391010	Film Cap., 390pF
C157	1	1	1	DD16150010	Ceramic Cap., 15pF ±10%
C158	1	1	1	DK18103010	Ceramic Cap., 0.01μF

- (U) for U.S.A.
- (C) for Canada
- (N) for Europe

REF. DESIG.	Q'TY			PART NO.	DESCRIPTION
	U	C	N		
C159	1	1	1	DK17103010	Ceramic Cap., 0.01 $\mu$ F $\pm$ 20%
C160	1	1	1	DD16820010	Ceramic Cap., 82pF $\pm$ 10%
C161	1	1	1	DK17103010	Ceramic Cap., 0.01 $\mu$ F $\pm$ 20%
C162	1	1	1	DK18403020	Ceramic Cap., 0.04 $\mu$ F
C163	1	1	1	EA10505090	Electrolytic Cap., 1 $\mu$ F 50V
C164	1	1	1	EA22601690	Electrolytic Cap., 22 $\mu$ F 16V
C165	1	1	1	EA47503590	Electrolytic Cap., 4.7 $\mu$ F 35V
C166	1	1	1	DK17102010	Ceramic Cap., 0.001 $\mu$ F $\pm$ 20%
C167	1	1	1	DK18103010	Ceramic Cap., 0.01 $\mu$ F
C168	1	1	1	DK16682010	Ceramic Cap., 0.0068 $\mu$ F $\pm$ 10%
C169	1	1	1	DK18403020	Ceramic Cap., 0.04 $\mu$ F
C170	1	1	1	EA10701690	Electrolytic Cap., 100 $\mu$ F 16V
C171	1	1	1	DF16104010	Film Cap., 0.1 $\mu$ F $\pm$ 10%
C172	1	1	1	EE47502510	Electrolytic Cap., 4.7 $\mu$ F 25V
F151	1	1	1	FF10045160	Ceramic Filter, AM CF SFD455D
J101	1	1	1	YP10001510	Plug
J102	1	1	1	YP10001510	Plug
J103	1	1	1	YP10001510	Plug
J105	1	1	1	YP10001510	Plug
J107	1	1	1	YP10001510	Plug
J109	1	1	1	YP10001510	Plug
J110	1	1	1	YP10001510	Plug
J111	1	1	1	YP10001510	Plug
L105	1	1	1	LC12220010	Choke Coil
L106	1	1	1	LI10239010	I.F.T.
L151	1	1	1	LC13320020	Choke Coil, 3.3 $\mu$ H
L152	1	1	1	LC13320020	Choke Coil, 3.3 $\mu$ H
L153	1	1	1	LC13320020	Choke Coil, 3.3 $\mu$ H
L154	1	1	1	LO10010480	Osc. Coil, AM
L155	1	1	1	LI10015010	I.F.T., AM
L156	1	1	1	LI10015060	I.F.T., AM
<b>P100 FM FRONT END BOARD</b>					
P100	1	1	1	YD29910010	P.W. Board
A201	1	1	1	AV01202060	Front End Assembly
Q101	1	1	1	HF40045180	F.E.T., 3SK45 B
Q102	1	1	1	HT30535280	Transistor, 2SC535 (B, C)
Q103	1	1	1	HT31342280	Transistor, 2SC1342 (B, C)
Q151	1	1	1	HC10019010	IC, HA1197
Q152	1	1	1	HT313272A0	Transistor, 2SC1327 (S, T)
Q153	1	1	1	HV00006120	Varistor, MV-203
R101	1	1	1	GD05105140	Resistor, 1M $\Omega$ $\pm$ 5% $\frac{1}{4}$ W
R102	1	1	1	GD05101140	Resistor, 100 $\Omega$ $\pm$ 5% $\frac{1}{4}$ W
R103	1	1	1	GD05101140	Resistor, 100 $\Omega$ $\pm$ 5% $\frac{1}{4}$ W
R104	1	1	1	GD05101140	Resistor, 100 $\Omega$ $\pm$ 5% $\frac{1}{4}$ W
R105	1	1	1	GD05223140	Resistor, 22k $\Omega$ $\pm$ 5% $\frac{1}{4}$ W
R106	1	1	1	GD05472140	Resistor, 4.7k $\Omega$ $\pm$ 5% $\frac{1}{4}$ W
R107	1	1	1	GD05102140	Resistor, 1k $\Omega$ $\pm$ 5% $\frac{1}{4}$ W
R108	1	1	1	GD05103140	Resistor, 10k $\Omega$ $\pm$ 5% $\frac{1}{4}$ W
R109	1	1	1	GD05332140	Resistor, 3.3k $\Omega$ $\pm$ 5% $\frac{1}{4}$ W
R110	1	1	1	GD05103140	Resistor, 10k $\Omega$ $\pm$ 5% $\frac{1}{4}$ W
R111	1	1	1	GD05101140	Resistor, 100 $\Omega$ $\pm$ 5% $\frac{1}{4}$ W
R151	1	1	1	RT05201140	Resistor, 200 $\Omega$ $\pm$ 5% $\frac{1}{4}$ W
R152	1	1	1	RT05152140	Resistor, 1.5k $\Omega$ $\pm$ 5% $\frac{1}{4}$ W
R153	1	1	1	RT05202140	Resistor, 2k $\Omega$ $\pm$ 5% $\frac{1}{4}$ W
R154	1	1	1	RT05152140	Resistor, 1.5k $\Omega$ $\pm$ 5% $\frac{1}{4}$ W

REF. DESIG.	Q'TY			PART NO.	DESCRIPTION
	U	C	N		
R155	1	1	1	RT05151140	Resistor, 150 $\Omega$ $\pm$ 5% $\frac{1}{4}$ W
R156	1	1	1	RA05020200	Trimming Resistor, 5k $\Omega$
R157	1	1	1	RT05391140	Resistor, 390 $\Omega$ $\pm$ 5% $\frac{1}{4}$ W
R158	1	1	1	RT05124140	Resistor, 120k $\Omega$ $\pm$ 5% $\frac{1}{4}$ W
R159	1	1	1	RT05104140	Resistor, 100k $\Omega$ $\pm$ 5% $\frac{1}{4}$ W
R160	1	1	1	RT05103140	Resistor, 10k $\Omega$ $\pm$ 5% $\frac{1}{4}$ W
R161	1	1	1	RT05473140	Resistor, 10k $\Omega$ $\pm$ 5% $\frac{1}{4}$ W
R162	1	1	1	RT05102140	Resistor, 1k $\Omega$ $\pm$ 5% $\frac{1}{4}$ W
R163	1	1	1	RT05301140	Resistor, 300 $\Omega$ $\pm$ 5% $\frac{1}{4}$ W
R164	1	1	1	RT05473140	Resistor, 47k $\Omega$ $\pm$ 5% $\frac{1}{4}$ W
R165	1	1	1	RT05104140	Resistor, 100k $\Omega$ $\pm$ 5% $\frac{1}{4}$ W
R166	1	1	1	RT05152140	Resistor, 1.5k $\Omega$ $\pm$ 5% $\frac{1}{4}$ W
R167	1	1	1	RT05242140	Resistor, 2.4k $\Omega$ $\pm$ 5% $\frac{1}{4}$ W
R169	1	1	1	RT05473140	Resistor, 47k $\Omega$ $\pm$ 5% $\frac{1}{4}$ W
R170	1	1	1	RT05101140	Resistor, 100 $\Omega$ $\pm$ 5% $\frac{1}{4}$ W
C201	1	1	1	DD15300010	Ceramic Cap., 30pF $\pm$ 5%
C202	1	1	1	DK17103010	Ceramic Cap., 0.01 $\mu$ F $\pm$ 20%
C203	1	1	1	DK17103010	Ceramic Cap., 0.01 $\mu$ F $\pm$ 20%
C204	1	1	1	DK17103010	Ceramic Cap., 0.01 $\mu$ F $\pm$ 20%
C205	1	1	1	DK18403020	Ceramic Cap., 0.04 $\mu$ F
C206	1	1	1	DK18403020	Ceramic Cap., 0.04 $\mu$ F
C207	1	1	1	DK18403020	Ceramic Cap., 0.04 $\mu$ F
C208	1	1	1	EA47503590	Electrolytic Cap., 4.7 $\mu$ F 35V
C209	1	1	1	DD15400040	Ceramic Cap., 40pF $\pm$ 5%
C210	1	1	1	EA22601690	Electrolytic Cap., 22 $\mu$ F 16V
C211	1	1	1	EA47405010	Electrolytic Cap., 0.47 $\mu$ F 50V
C212	1	1	1	DK18403010	Ceramic Cap., 0.04 $\mu$ F
C213	1	1	1	DK18403010	Ceramic Cap., 0.04 $\mu$ F
C214	1	1	1	DK18403010	Ceramic Cap., 0.04 $\mu$ F
C215	1	1	1	DK18403010	Ceramic Cap., 0.04 $\mu$ F
C216	1	1	1	DK18403010	Ceramic Cap., 0.04 $\mu$ F
C217	1	1	1	EA10505090	Electrolytic Cap., 1 $\mu$ F 50V
C218	1	1	1	EA10505090	Electrolytic Cap., 1 $\mu$ F 50V
F201	1	1	1	FF11070050	Ceramic Filter, FM CF SFE10.7MD1
F202	1	1	1	FF11070050	Ceramic Filter, FM CF SFE10.7MD1
F203	1	1	1	FF11070050	Ceramic Filter, FM CF SFE10.7MD1
J201					
J229	33	33	33	YP10001130	Plug
J231	1	1	1	YP10001130	Plug
J232	1	1	1	YP10001130	Plug
J233	1	1	1	YP10001130	Plug, AM Test Point
L202	1	1	1	LI14019010	I.F.T., FM
L203	1	1	1	LC11830010	Choke Coil, 18 $\mu$ H
<b>P200 FM MPX BOARD</b>					
P200	1	1	1	YD22042012	P.W. Board
	1	1		ZZZ22092010	P.W. Board Assembly
			1	ZZZ22098010	P.W. Board Assembly
Q201	1	1	1	HT310471C0	Transistor, 2SC1047 C
Q202	1	1	1	HC10021010	IC, HA1137W
Q203	1	1	1	HD20001210	Diode, 1S2473
Q204	1	1	1	HD20001210	Diode, 1S2473
Q205	1	1	1	HD20001210	Diode, 1S2473
Q206	1	1	1	HT308281D0	Transistor, 2SC828 S
Q207	1	1	1	HD20001210	Diode, 1S2473
R201	1	1	1	RT05151140	Resistor, 150 $\Omega$ $\pm$ 5% $\frac{1}{4}$ W

• (U) for U.S.A.  
• (C) for Canada  
• (N) for Europe

REF. DESIG.	Q'TY			PART NO.	DESCRIPTION
	U	C	N		
J401 J438 L401	38	38	38	YP10001130	Plug
P400	1	1	1	LC11540020	Choke Coil, 150μH
					<b>P400 PHONO AMP. &amp; SELECTOR BOARD</b>
	1	1	1	YK22050210	P.W. Board
	1	1	1	ZZ22050210	P.W. Board Assembly
Q401	1	1	1	HT316811B0	Transistor, 2SC1681 (BL)
Q402	1	1	1	HT316811B0	Transistor, 2SC1681 (BL)
Q403	1	1	1	HT316812A0	Transistor, 2SC1681 (GR, BL)
Q404	1	1	1	HT316812A0	Transistor, 2SC1681 (GR, BL)
Q405	1	1	1	HT316811B0	Transistor, 2SC1681 (BL)
Q406	1	1	1	HT316811B0	Transistor, 2SC1681 (BL)
R401	1	1	1	RT05913140	Resistor, 91kΩ ±5% ¼W
R402	1	1	1	RT05913140	Resistor, 91kΩ ±5% ¼W
R403	1	1	1	RT05471140	Resistor, 470Ω ±5% ¼W
R404	1	1	1	RT05471140	Resistor, 470Ω ±5% ¼W
R405	1	1	1	RT05394140	Resistor, 390kΩ ±5% ¼W
R406	1	1	1	RT05394140	Resistor, 390kΩ ±5% ¼W
R407	1	1	1	RT05223140	Resistor, 22kΩ ±5% ¼W
R408	1	1	1	RT05223140	Resistor, 22kΩ ±5% ¼W
R409	1	1	1	RT05681140	Resistor, 680Ω ±5% ¼W
R410	1	1	1	RT05681140	Resistor, 680Ω ±5% ¼W
R411	1	1	1	RT05104140	Resistor, 100kΩ ±5% ¼W
R412	1	1	1	RT05104140	Resistor, 100kΩ ±5% ¼W
R413	1	1	1	RT05303140	Resistor, 30kΩ ±5% ¼W
R414	1	1	1	RT05303140	Resistor, 30kΩ ±5% ¼W
R415	1	1	1	RT05562140	Resistor, 5.6kΩ ±5% ¼W
R416	1	1	1	RT05562140	Resistor, 5.6kΩ ±5% ¼W
R417	1	1	1	RT05182140	Resistor, 1.8kΩ ±5% ¼W
R418	1	1	1	RT05182140	Resistor, 1.8kΩ ±5% ¼W
R419	1	1	1	RT05472140	Resistor, 4.7kΩ ±5% ¼W
R420	1	1	1	RT05472140	Resistor, 4.7kΩ ±5% ¼W
R421	1	1	1	RT05224140	Resistor, 220kΩ ±5% ¼W
R422	1	1	1	RT05224140	Resistor, 220kΩ ±5% ¼W
R423	1	1	1	RT05473140	Resistor, 47kΩ ±5% ¼W
R424	1	1	1	RT05473140	Resistor, 47kΩ ±5% ¼W
R425	1	1	1	RT05152140	Resistor, 1.5kΩ ±5% ¼W
R426	1	1	1	RT05152140	Resistor, 1.5kΩ ±5% ¼W
R427	1	1	1	RT05564140	Resistor, 560kΩ ±5% ¼W
R428	1	1	1	RT05564140	Resistor, 560kΩ ±5% ¼W
R429	1	1	1	RT05101140	Resistor, 100Ω ±5% ¼W
R430	1	1	1	GF05330120	Resistor, 33Ω ±5% ¼W
R431	1	1	1	GF05390140	Resistor, 39Ω ±5% ¼W
S401	1	1	1	SR10050130	Rotary Switch, Selector
C701	1	1	1	EE33502540	Electrolytic Cap., 3.3μF ±20% 25V
C702	1	1	1	EE33502540	Electrolytic Cap., 3.3μF ±20% 25V
C703	1	1	1	DD16201010	Ceramic Cap., 200pF ±10% 50V
C704	1	1	1	DD16201010	Ceramic Cap., 200pF ±10% 50V
C705	1	1	1	EE47601640	Electrolytic Cap., 47μF ±20% 16V
C706	1	1	1	EE47601640	Electrolytic Cap., 47μF ±20% 16V
C707	1	1	1	DD11050500	Ceramic Cap., 5pF ±0.25pF 500V
C708	1	1	1	DD11050500	Ceramic Cap., 5pF ±0.25pF 500V
C709	1	1	1	EA47605090	Electrolytic Cap., 47μF ±30% 50V
C710	1	1	1	EA47605090	Electrolytic Cap., 47μF ±30% 50V
C711	1	1	1	DF16103050	Film Cap., 0.01μF ±10% 50V

REF. DESIG.	Q'TY			PART NO.	DESCRIPTION
	U	C	N		
C712	1	1	1	DF16103050	Film Cap., 0.01μF ±10% 50V
C713	1	1	1	DF16103050	Film Cap., 0.01μF ±10% 50V
C714	1	1	1	DF16103050	Film Cap., 0.01μF ±10% 50V
C715	1	1	1	DF17104010	Film Cap., 0.1μF ±20% 50V
C716	1	1	1	DF17104010	Film Cap., 0.1μF ±20% 50V
C717	1	1	1	DF17104010	Film Cap., 0.1μF ±20% 50V
C718	1	1	1	DF17104010	Film Cap., 0.1μF ±20% 50V
C719	1	1	1	EE10601640	Electrolytic Cap., 10μF ±20% 16V
C720	1	1	1	EE10601640	Electrolytic Cap., 10μF ±20% 16V
C721	1	1	1	EE10601640	Electrolytic Cap., 10μF ±20% 16V
C722	1	1	1	EE10601640	Electrolytic Cap., 10μF ±20% 16V
C723	1	1	1	DK16101500	Ceramic Cap., 100pF ±10% 500V
C724	1	1	1	DK16101500	Ceramic Cap., 100pF ±10% 500V
C725	1	1	1	DK16101500	Ceramic Cap., 100pF ±10% 500V
C726	1	1	1	DK16101500	Ceramic Cap., 100pF ±10% 500V
C727	1	1	1	DF17104520	Film Cap., 0.1μF ±20% 200V
C728	1	1	1	DF17104520	Film Cap., 0.1μF ±20% 200V
C729	1	1	1	EA22705090	Electrolytic Cap., 220μF ±30% 50V
C730	1	1	1	EA47601690	Electrolytic Cap., 47μF ±30% 16V
C731	1	1	1	EA22701090	Electrolytic Cap., 220μF ±30% 10V
C732	1	1	1	DK18103510	Ceramic Cap., 0.01μF ±10% 500V
C733	1	1	1	EA47706310	Electrolytic Cap., 470μF ±30% 63V
C734	1	1	1	EA10706310	Electrolytic Cap., 100μF ±30% 63V
C735	1	1	1	EA33605090	Electrolytic Cap., 33μF ±30% 50V
C736	1	1	1	DF17473050	Film Cap., 0.047μF ±20% 50V
C737	1	1	1	EA10701690	Electrolytic Cap., 100μF ±30% 16V
C738	1	1	1	EA10605090	Electrolytic Cap., 10μF ±30% 50V
C739	1	1	1	EA10801690	Electrolytic Cap., 1000μF ±30% 16V
C740	1	1	1	EE10605040	Electrolytic Cap., 10μF ±20% 50V
F701	1	1	1	FS10100080	Fuse, MGC 1A 30mm
F701	1	1	1	FS10100800	Fuse, SGA 1A 20mm SEMKO
F702	1	1	1	FS10200060	Fuse, MGA 2A 30mm
F702	1	1	1	FS10200800	Fuse, SGA 2A 20mm SEMKO
J701					
J728	28	28	28	YP10001130	Plug
J729					
J729	4	4	4	YJ08000210	Jack, Fuse Holder
J732					
J733					
J733	4	4	4	YJ05000260	Jack, Tr. Socket
J736					
J737	1	1	1	YP10001130	Plug, Pin
J738	1	1	1	YP10001130	Plug, Pin
J739	1	1	1	YP10001130	Plug, Pin
L701	1	1	1	LC22620010	Choke Coil, 2.6μH
L702	1	1	1	LC22620010	Choke Coil, 2.6μH
L703	1	1	1	LY40240050	Relay
P700	1	1	1	YG22070010	<b>P700 MAIN AMP. &amp; POWER SUPPLY BOARD</b>
	1	1	1	ZZ22070010	P.W. Board Assembly
Q701	1	1	1	HT107502B0	Transistor, 2SA 750 (T, U)
Q702	1	1	1	HT107502B0	Transistor, 2SA 750 (T, U)
Q703	1	1	1	HT107502B0	Transistor, 2SA 750 (T, U)
Q704	1	1	1	HT107502B0	Transistor, 2SA 750 (T, U)
Q705	1	1	1	HT318853B0	Transistor, 2SC1885 (Q, R, S)
Q706	1	1	1	HT318853B0	Transistor, 2SC1885 (Q, R, S)

• (U) for U.S.A  
 • (C) for Canad.  
 • (N) for Europ

REF. DESIG.	Q'TY			PART NO.	DESCRIPTION
	U	C	N		
Q707	1	1	1	HT315672B0	Transistor, 2SC1567 (Q, R)
Q708	1	1	1	HT315672B0	Transistor, 2SC1567 (Q, R)
Q709	1	1	1	HT107942B0	Transistor, 2SA 794 (Q, R)
Q710	1	1	1	HT107942B0	Transistor, 2SA 794 (Q, R)
Q711	1	1	1	HT403883A0	Transistor, 2SD 388 (S, R, Q)
Q712	1	1	1	HT403883A0	Transistor, 2SD 388 (S, R, Q)
Q713	1	1	1	HT205413A0	Transistor, 2SB 541 (S, R, Q)
Q714	1	1	1	HT205413A0	Transistor, 2SB 541 (S, R, Q)
Q715	1	1	1	HT309451Q0	Transistor, 2SC 945 (Q)
Q716	1	1	1	HT309451Q0	Transistor, 2SC 945 (Q)
Q717	1	1	1	HT107331Q0	Transistor, 2SA 733 (Q)
Q718	1	1	1	HT107331Q0	Transistor, 2SA 733 (Q)
Q719	1	1	1	HV00003120	Varistor, MV-13
Q720	1	1	1	HV00003120	Varistor, MV-13
Q721	1	1	1	HV00003120	Varistor, MV-13
Q722	1	1	1	HV00003120	Varistor, MV-13
Q723	1	1	1	HD20002210	Diode, 1S2472 (GR)
Q724	1	1	1	HD20002210	Diode, 1S2472 (GR)
Q725	1	1	1	HD20002210	Diode, 1S2472 (GR)
Q726	1	1	1	HD20002210	Diode, 1S2472 (GR)
Q727	1	1	1	HD20002210	Diode, 1S2472 (GR)
Q728	1	1	1	HD20002210	Diode, 1S2472 (GR)
Q729	1	1	1	HD20002210	Diode, 1S2472 (GR)
Q730	1	1	1	HD20002210	Diode, 1S2472 (GR)
Q731	1	1	1	HD20002210	Diode, 1S2472 (GR)
Q732	1	1	1	HD20002210	Diode, 1S2472 (GR)
Q733	1	1	1	HD20002210	Diode, 1S2472 (GR)
Q734	1	1	1	HD20002210	Diode, 1S2472 (GR)
Q735	1	1	1	HH00003030	Thermistor, STD-04
Q736	1	1	1	HH00003030	Thermistor, STD-04
Q737	1	1	1	HD20005010	Diode, W06B
Q738	1	1	1	HD20005010	Diode, W06B
Q739	1	1	1	HD20005010	Diode, W06B
Q740	1	1	1	HD20005010	Diode, W06B
Q741	1	1	1	HV00005080	Varistor, STV-3H (Y)
Q742	1	1	1	HV00005080	Varistor, STV-3H (Y)
Q743	1	1	1	HT309452A0	Transistor, 2SC 945 (R, Q)
Q744	1	1	1	HT309452A0	Transistor, 2SC 945 (R, Q)
Q745	1	1	1	HT313182C0	Transistor, 2SC1318 (R, S)
Q746	1	1	1	HD20003210	Diode, 1S2471 (BK)
Q747	1	1	1	HD20011030	Diode, DS-131B
Q748	1	1	1	HD20012030	Diode, DS-132B
Q749	1	1	1	HD20005010	Diode, W06B
Q750	1	1	1	HT318853B0	Transistor, 2SC1885 (Q, R, S)
Q751	1	1	1	HT309452A0	Transistor, 2SC 945 (P, Q)
Q752	1	1	1	HD30025090	Zener, WZ-15C
Q753	1	1	1	HT403302A0	Transistor, 2SD330 (D, E)
Q754	1	1	1	HD20005010	Diode, W06B
R701	1	1	1	RT05102140	Resistor, 1kΩ ±5% ¼W
R702	1	1	1	RT05102140	Resistor, 1kΩ ±5% ¼W
R703	1	1	1	RT05333140	Resistor, 33kΩ ±5% ¼W
R704	1	1	1	RT05333140	Resistor, 33kΩ ±5% ¼W
R705	1	1	1	RT05682140	Resistor, 6.8kΩ ±5% ¼W
R706	1	1	1	RT05682140	Resistor, 6.8kΩ ±5% ¼W
R707	1	1	1	RT05102140	Resistor, 1kΩ ±5% ¼W
R708	1	1	1	RT05102140	Resistor, 1kΩ ±5% ¼W
R709	1	1	1	RT05472140	Resistor, 4.7kΩ ±5% ¼W
R710	1	1	1	RT05472140	Resistor, 4.7kΩ ±5% ¼W

REF. DESIG.	Q'TY			PART NO.	DESCRIPTION
	U	C	N		
R711	1	1	1	RA05020200	Trimming Resistor, 5kΩ (B)
R712	1	1	1	RA05020200	Trimming Resistor, 5kΩ (B)
R713	1	1	1	RT05103140	Resistor, 10kΩ ±5% ¼W
R714	1	1	1	RT05103140	Resistor, 10kΩ ±5% ¼W
R715	1	1	1	RT05224140	Resistor, 220kΩ ±5% ¼W
R716	1	1	1	RT05224140	Resistor, 220kΩ ±5% ¼W
R717	1	1	1	RT05302140	Resistor, 3kΩ ±5% ¼W
R718	1	1	1	RT05302140	Resistor, 3kΩ ±5% ¼W
R719	1	1	1	RT05333140	Resistor, 33kΩ ±5% ¼W
R720	1	1	1	RT05333140	Resistor, 33kΩ ±5% ¼W
R721	1	1	1	GF05330140	Resistor, 33Ω ±5% ¼W
R722	1	1	1	GF05330140	Resistor, 33Ω ±5% ¼W
R723	1	1	1	RT05302140	Resistor, 3kΩ ±5% ¼W
R724	1	1	1	RT05302140	Resistor, 3kΩ ±5% ¼W
R725	1	1	1	RT05302140	Resistor, 3kΩ ±5% ¼W
R726	1	1	1	RT05302140	Resistor, 3kΩ ±5% ¼W
R727	1	1	1	RT05152140	Resistor, 1.5kΩ ±5% ¼W
R728	1	1	1	GF05330120	Resistor, 33Ω ±5% ½W
R729	1	1	1	RT05820140	Resistor, 82Ω ±5% ¼W
R730	1	1	1	RT05820140	Resistor, 82Ω ±5% ¼W
R731	1	1	1	RA01020210	Trimming Resistor, 1kΩ (B)
R732	1	1	1	RA01020210	Trimming Resistor, 1kΩ (B)
R733	1	1	1	RT05161140	Resistor, 160Ω ±5% ¼W
R734	1	1	1	RT05161140	Resistor, 160Ω ±5% ¼W
R735	1	1	1	GF05271140	Resistor, 270Ω ±5% ¼W
R736	1	1	1	GF05271140	Resistor, 270Ω ±5% ¼W
R737	1	1	1	GF05271140	Resistor, 270Ω ±5% ¼W
R738	1	1	1	GF05271140	Resistor, 270Ω ±5% ¼W
R739	1	1	1	GF05221140	Resistor, 220Ω ±5% ¼W
R740	1	1	1	GF05221140	Resistor, 220Ω ±5% ¼W
R741	1	1	1	GF05221140	Resistor, 220Ω ±5% ¼W
R742	1	1	1	GF05221140	Resistor, 220Ω ±5% ¼W
R743	1	1	1	GF05221140	Resistor, 220Ω ±5% ¼W
R744	1	1	1	GF05221140	Resistor, 220Ω ±5% ¼W
R745	1	1	1	GF05271140	Resistor, 270Ω ±5% ¼W
R746	1	1	1	GF05271140	Resistor, 270Ω ±5% ¼W
R747	1	1	1	GF05222140	Resistor, 2.2kΩ ±5% ¼W
R748	1	1	1	GF05222140	Resistor, 2.2kΩ ±5% ¼W
R749	1	1	1	GF05242140	Resistor, 2.4kΩ ±5% ¼W
R750	1	1	1	GF05242140	Resistor, 2.4kΩ ±5% ¼W
R751	1	1	1	GF05273140	Resistor, 27kΩ ±5% ¼W
R752	1	1	1	GF05273140	Resistor, 27kΩ ±5% ¼W
R753	1	1	1	GF05100140	Resistor, 10Ω ±5% ¼W
R754	1	1	1	GF05100140	Resistor, 10Ω ±5% ¼W
R755	1	1	1	GF05100140	Resistor, 10Ω ±5% ¼W
R756	1	1	1	GF05100140	Resistor, 10Ω ±5% ¼W
R757	1	1	1	GF05151120	Resistor, 150Ω ±5% ½W
R758	1	1	1	GF05151120	Resistor, 150Ω ±5% ½W
R759	1	1	1	GF05151120	Resistor, 150Ω ±5% ½W
R760	1	1	1	GF05151120	Resistor, 150Ω ±5% ½W
R761	1	1	1	GJ05100020	Resistor, 10Ω ±5% 2W
R762	1	1	1	GJ05100020	Resistor, 10Ω ±5% 2W
R763	1	1	1	GW10392030	Resistor, 0.39Ω ±10% 3W
R764	1	1	1	GW10392030	Resistor, 0.39Ω ±10% 3W
R765	1	1	1	GW10392030	Resistor, 0.39Ω ±10% 3W
R766	1	1	1	GW10392030	Resistor, 0.39Ω ±10% 3W
R767	1	1	1	RC10022120	Resistor, 2.2Ω ±10% ¼W