

SERVICE MANUAL



marantz

model 2265B

Stereophonic Receiver

TABLE OF CONTENTS

Section	Title	Page
1.	P.W. BOARDS	1
2.	TEST EQUIPMENT REQUIRED FOR SERVICING	1
3.	AM ALIGNMENT PROCEDURES	2
3.1	AM IF Alignment	2
3.2	AM Frequency Range and Tracking Alignment	2
3.3	AM Signal Strength Meter Alignment	2
4.	FM ALIGNMENT PROCEDURES	2
4.1	FM Frequency Range and Tracking Alignment	2
4.2	Stereo Separation Alignment	2
4.3	Muting Circuit Alignment	2
4.4	Dolby FM Tape Output Setting	2
5.	AUDIO ADJUSTMENT	2
6.	VOLTAGE CONVERSION FOR EUROPEAN MODEL	3
7.	DIAGRAMS	5
7.1	Block Diagram	5
7.2	Connection Diagram - U.S.A. & Canada	7
7.3	Connection Diagram - Europe	9
8.	SCHEMATIC DIAGRAMS AND COMPONENT LOCATIONS	11
8.1	FM Front End Circuit Board P100	11
8.2	AM Tuner, FM IF & MPX Decoder Circuit Board P200	12
8.3	Phono Amp Circuit Board P400	13
8.4	Main Amp Circuit Board P700	14
8.5	Power Supply Circuit Board P800	15
8.6	Pre and Tone Amp Circuit Board PE01	16
8.7	Monitor and Filter Switches Circuit Board PS01	17
8.8	Dolby Socket Circuit Board PK01	18
8.9	Function Lamp Circuit Board PY01	18
8.10	Dial Lamp Circuit Board PZ01	18
8.11	Antenna Muting Circuit Board PC01	18
8.12	Speaker Switches Circuit Board PN01	19
9.	MAJOR COMPONENT LOCATIONS	20
9.1	Cabinet - Front View	20
9.2	Chassis - Top View	20
9.3	Cabinet - Rear View	21
9.4	Chassis - Bottom View	21
10.	EXPLODED VIEWS	22
10.1	Rear Panel Exploded View - U.S.A. & Canada	22
10.2	Rear Panel Exploded View - Europe	22
10.3	Front Panel Exploded View	23
10.4	Chassis Exploded View	25
10.5	Packing Material Exploded View	27
11.	PARTS LIST	28
12.	TECHNICAL SPECIFICATIONS	40
13.	SCHEMATIC DIAGRAMS	43

INTRODUCTION

This service manual was prepared for use by Authorized Warranty Stations and contains service information for Marantz Model 2265B Stereophonic Receiver.

Servicing information and voltage data included in this manual are intended for use by the knowledgeable and experienced technician only. All instructions should be read carefully. No attempt should be made to proceed without a good understanding of the operation of the receiver.

The parts list furnishes information by which replacement parts may be ordered from the Marantz Company. A simple description is included for parts which can usually be obtained through local suppliers.

1. P.W. BOARDS

As can be seen from the circuit diagram, the chassis of Model 2265B consists of the following units. Each unit mounted on a printed circuit board is described within the square enclosed by a bold dotted line on the circuit diagram.

1. FM Front End mounted on P.W. Board P100
2. AM Tuner, FM IF & MPX
Stereo Decoder mounted on P.W. Board P200
3. Dolby Socket mounted on P.W. Board PK01
4. Phono Amp mounted on P.W. Board P400
5. Main Amp mounted on P.W. Board P700
6. Power Supply mounted on P.W. Board P800
7. Pre & Tone Amp mounted on P.W. Board PE01
8. Monitor & Filter
Switches mounted on P.W. Board PS01
9. Function Lamp mounted on P.W. Board PY01
10. Dial Lamp mounted on P.W. Board PZ01
11. Antenna Muting mounted on P.W. Board PC01
12. Speaker Switches mounted on P.W. Board PN01
13. Fuse mounted on P.W. Board PP01

2. TEST EQUIPMENT REQUIRED FOR SERVICING

This table lists the test equipment required for servicing the Model 2265B Receiver

Item	Manufacturer and Model No.	Use
AM Signal Generator		Signal source for AM alignment
Test Loop		Use with AM Signal Generator
FM Signal Generator MPX Signal Generator	Sound Technology Model 1000A	Signal source for FM alignment Stereo separation alignment and trouble shooting
Distortion Analyzer Audio Oscillator AC VTVM	Sound Technology Model 1700A	Distortion measurements Sinewave and squarewave signal source Voltage measurements (AC)
Oscilloscope	Tektronix Model T932 Philips Model 3232	Waveform analysis and trouble shooting and ASO alignment
Frequency Counter	Fluke Model 1900A	MPX Oscillator adjustment (VCO)
Circuit Tester		Trouble shooting
DC VTVM	Fluke Model 8000 "Digital" Simpson Model 313, Triplet Model 801	Voltage measurements (DC)
AC Wattmeter	Simpson Model 1379	Monitors primary power to amplifier
AC Ammeter	Commercial Grade (1-10A)	Monitors amplifier output under short circuit condition
Line Voltmeter	Simpson Model 1359	Monitors potential of primary power to amplifier
Variable Autotransformer	Superior Electronic Co., Powerstat Model 116B-10A	Adjusts level of primary power to amplifier
Shorting Plug	Use phono plug with 600-ohm across center pin and shell	Shorts amplifier input to eliminate noise pickup
Output Load (8 ohms, 0.5%, 100W)	Commercial Grade	Provides 8-ohm load for amplifier output termination
Output Load (4 ohms, 0.5%, 100W)	Commercial Grade	Provides 4-ohm load for amplifier output termination

3. AM ALIGNMENT PROCEDURES

3.1 AM IF ALIGNMENT

1. Connect a sweep generator to the J155 and an alignment scope to the test point B.
2. Rotate each core of IF transformers L155 and L156 for maximum height and flat top symmetrical response.

3.2 AM FREQUENCY RANGE AND TRACKING ALIGNMENT

1. Set an AM signal generator to 515 kHz. Turn the tuning capacitor fully closed (place the tuning pointer at the low end) and adjust the oscillator coil L153 for maximum audio output.
2. Set the signal generator to 1650 kHz. Place the tuning pointer in the high frequency end and adjust the oscillator trimmer on the oscillator tuning capacitor for maximum audio output.
3. Repeat steps 1 and 2 until no further adjustment is necessary.
4. Set the generator to 600 kHz and tune the receiver to the same frequency and adjust a slug core of AM ferrite-rod antenna L001 and RF coil L152 for maximum output.
5. Set the generator to 1400 kHz and tune the receiver to the same frequency and adjust both trimming capacitors of antenna and RF tuned circuit for maximum output.
6. Repeat steps 4 and 5 until no further adjustment is necessary.

NOTE: During tracking alignment reduce the signal generator output as necessary to avoid AGC action.

3.3 AM SIGNAL STRENGTH METER ALIGNMENT

Set an AM signal generator to 1000 kHz at 5 μV , and adjust R157 so that the signal strength meter may read 90% of the full scale.

4. FM ALIGNMENT PROCEDURES

4.1 FM FREQUENCY RANGE AND TRACKING ALIGNMENT

1. Connect an FM signal generator to the FM ANTENNA terminals and an oscilloscope and an audio distortion analyzer to the TAPE MONITOR OUT jacks on the rear panel.
2. Set the signal generator to 87 MHz and provide about 3 to 5 μV . Place the tuning pointer at the low frequency end by rotating the tuning knob and adjust the core of oscillator coil L105 to obtain maximum audio output.
3. Set the signal generator to 109 MHz and provide about 3 to 5 μV output. Rotate the tuning knob and place the tuning pointer at the high frequency end and adjust the trimming capacitor CF04 for maximum output.
4. Repeat steps 2 and 3 until no further adjustment is necessary.
5. Set the signal generator to 90 MHz and tune the receiver to the same frequency. Decrease signal generator output until the audio output level decreases with the decreasing generator output. Adjust the antenna coil L101, RF coils L102, L103 and L104 and IF transformer L106 for minimum audio distortion.

6. Set the signal generator to 106 MHz and tune the receiver to the same frequency. Adjust the trimming capacitors CF01, CF02 and CF03 for minimum distortion.
7. Repeat steps 5 and 6 until no further adjustment is necessary.
8. Adjust the primary core (lower) of discriminator transformer L203 so that the center tuning meter pointer indicates its center at no signal applied. Set the FM signal generator to 98 MHz and increase its output level 1 μV and tune the receiver to the same frequency so that the center tuning meter pointer indicates its center. Adjust the secondary core (upper) of L203 for minimum distortion.
9. Set the signal generator to 98 MHz at 1000 μV , and adjust R227 so that the signal strength meter may read 90% of the full scale.

4.2 STEREO SEPARATION ALIGNMENT

1. Set the FM signal generator to provide 1 μV at 98 MHz. Tune the receiver to the same frequency so that the center tuning meter pointer indicates its center.
2. Turn the signal generator modulation off (with the pilot signal turned off), connect a frequency counter to test point J318, and adjust R307 so that the frequency counter may precisely read 76 kHz.
3. Modulate the signal generator with stereo composite signal consisting only of subchannel signal (of course a pilot signal must be included).
4. Adjust the trimming resistor R316 for maximum and same separation in both channels.

4.3 MUTING CIRCUIT ALIGNMENT

1. Set the FM signal generator to provide 30 μV or more at 98 MHz and tune the receiver to the same frequency correctly.
2. Set the semifixed resistor RC01 to the maximum position.
3. Depress the FM MUTING pushswitch.
4. Adjust the semifixed resistor RC02 for muting "on".

4.4 DOLBY FM TAPE OUTPUT SETTING

1. Set the modulation of the FM signal generator to 400 Hz, 50% (± 37.5 kHz Dev.).
2. Set the signal generator to provide 1 μV at 98 MHz. Tune the receiver to the same frequency so that the center tuning meter pointer indicates its center.
3. Turn the SELECTOR switch to FM 25 μS position. Set the semifixed resistors R332 and R333 so that the output of the TAPE MONITOR OUT jacks R and L become 580 mV at VTVM.

5. AUDIO ADJUSTMENT

1. Main Amplifier DC off-set alignment
Connect a DC voltmeter with 0.5 or 1 V range between the speaker terminals and adjust the semifixed resistor R710 for "zero" DC output on the meter. Repeat the same procedure for the other channel.

NOTE: During this alignment no load should be connected to the speaker terminals.

2. Idle-current adjustment

Connect a VTVM between pin terminals J717 and J718. Next, adjust the semifixed resistor R716 so that the VTVM reads 20 mV DC. Repeat the same procedure for the other channel.

3. Check DC off-set voltage aligned in the procedure 1 and if any DC output is observed on the DC voltmeter, adjust the R710 again for "zero" output.

6. VOLTAGE CONVERSION FOR EUROPEAN MODEL

The European version of the Model 2265B is equipped with a universal power transformer that may be adjusted to operate at 110 V, 120 V, 220 V, or 240 V AC at 50 to 60 Hz. To convert the unit to a different power source voltage, reposition conversion plug at shown in Figure 1.

CAUTION: DISCONNECT POWER SUPPLY CORD FROM AC OUTLET BEFORE CONVERTING VOLTAGE.

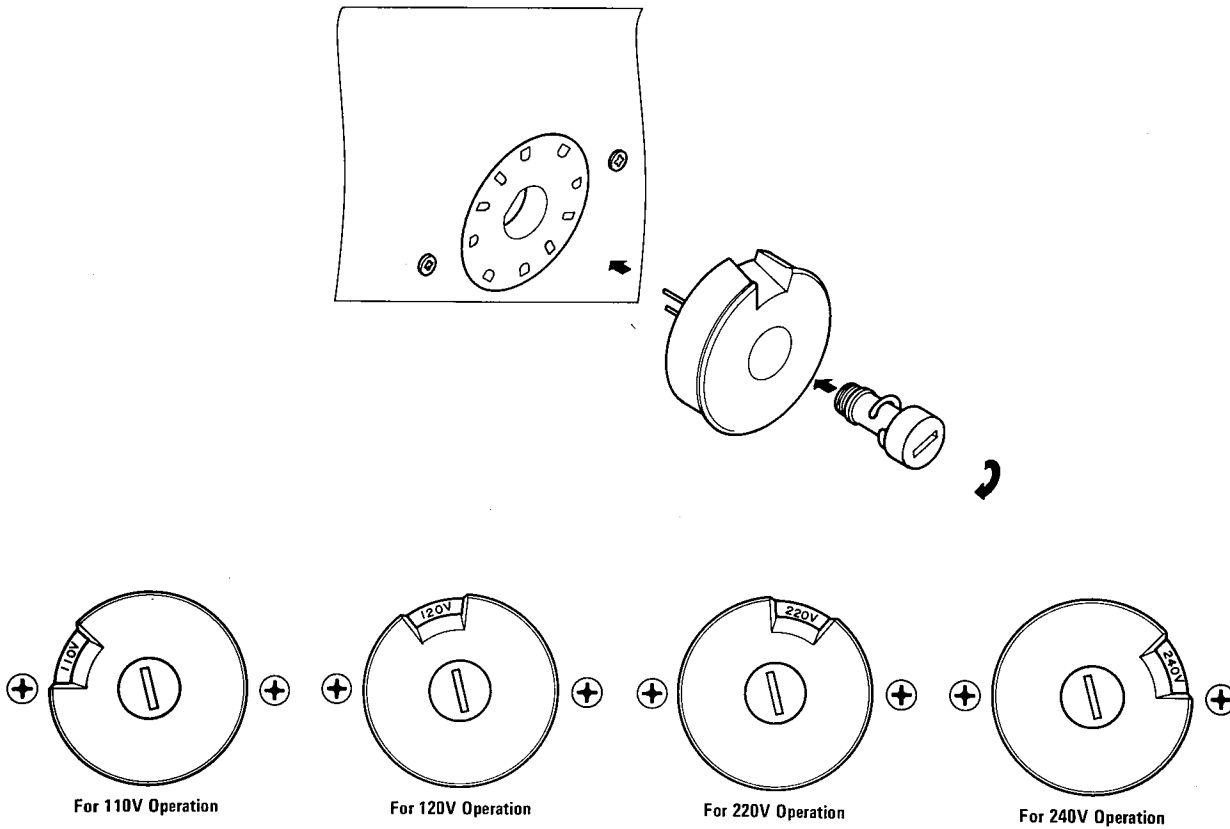

Figure 1. Voltage Conversion Chart

FTZ REGULATION

Instruction for the use in the range other than specified in FTZ codes.

Achtung für die Leute, die in dem Gebiet wohnen, wo die FTZ-Bestimmungen vorherrschend sind.

Sollte das Gerät auch für Frequenzen ausserhalb des in den FTZ-Bestimmungen angegebenen Bereiches empfangsbereit sein, bitten wir, den Bereich durch Nachstellen des Kernes in der Oszillatorspule (in der Abbildung mit "FTZ" gekennzeichnet) so zu korrigieren, dass er den Bestimmungen entspricht.

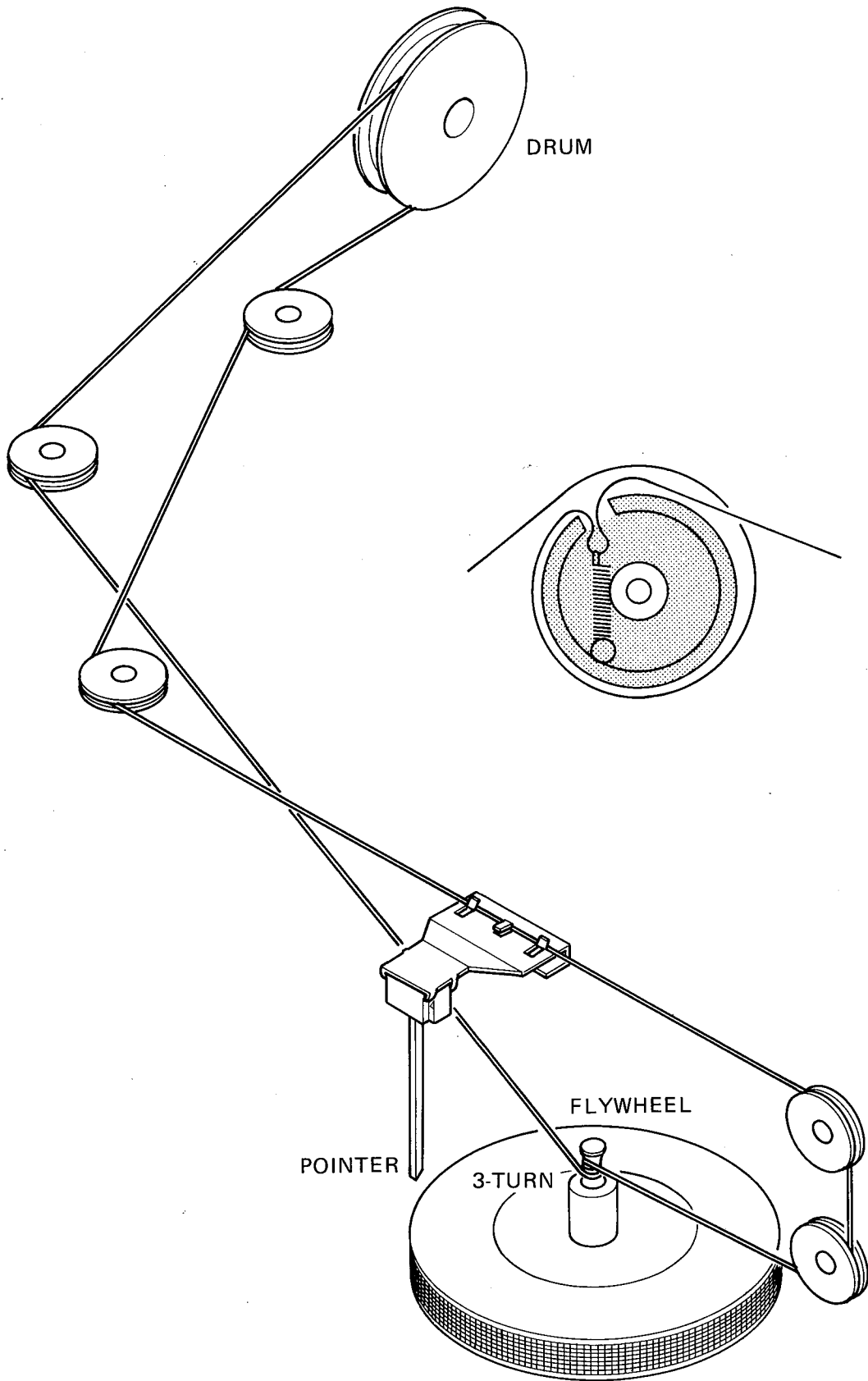
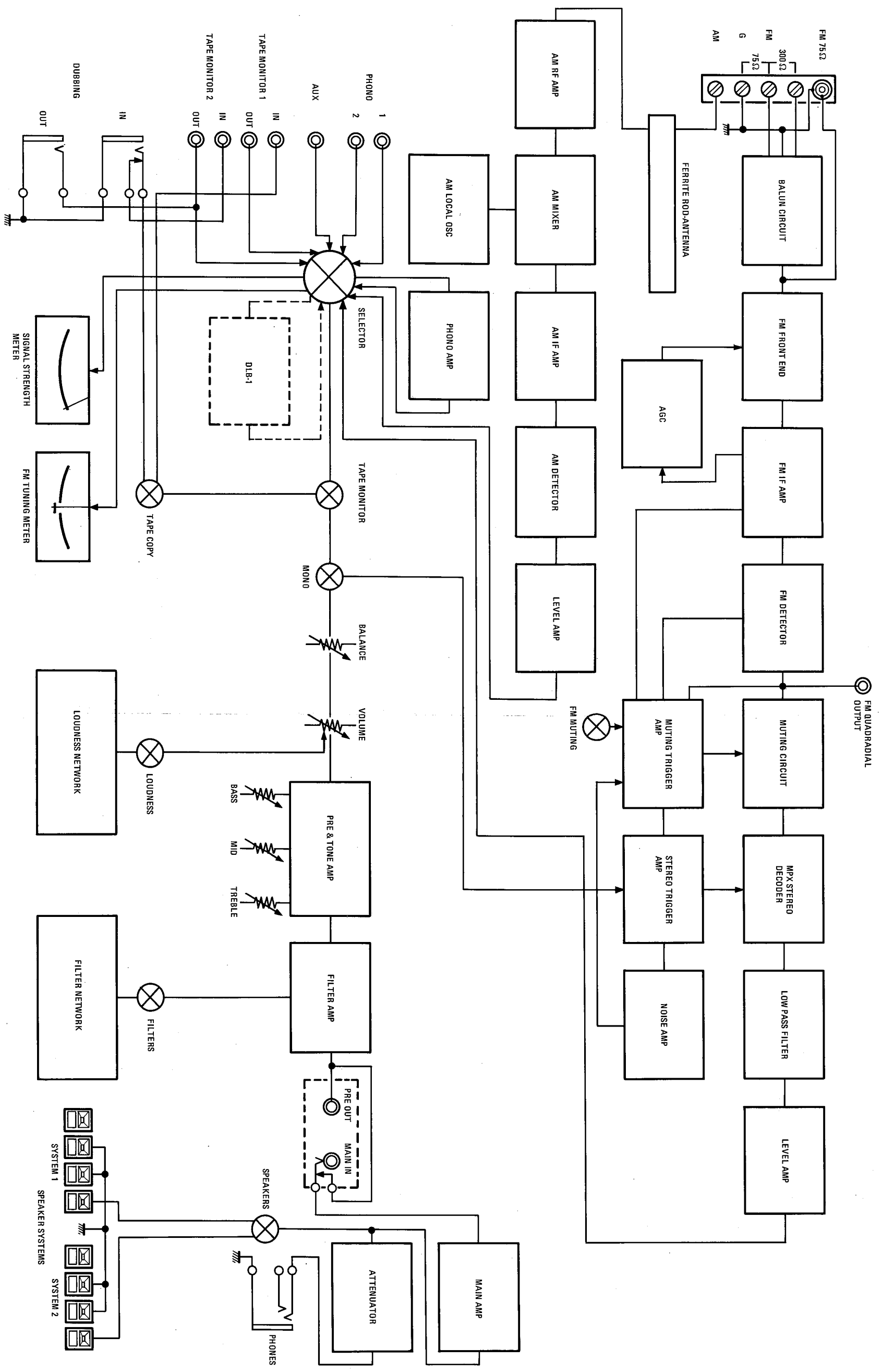
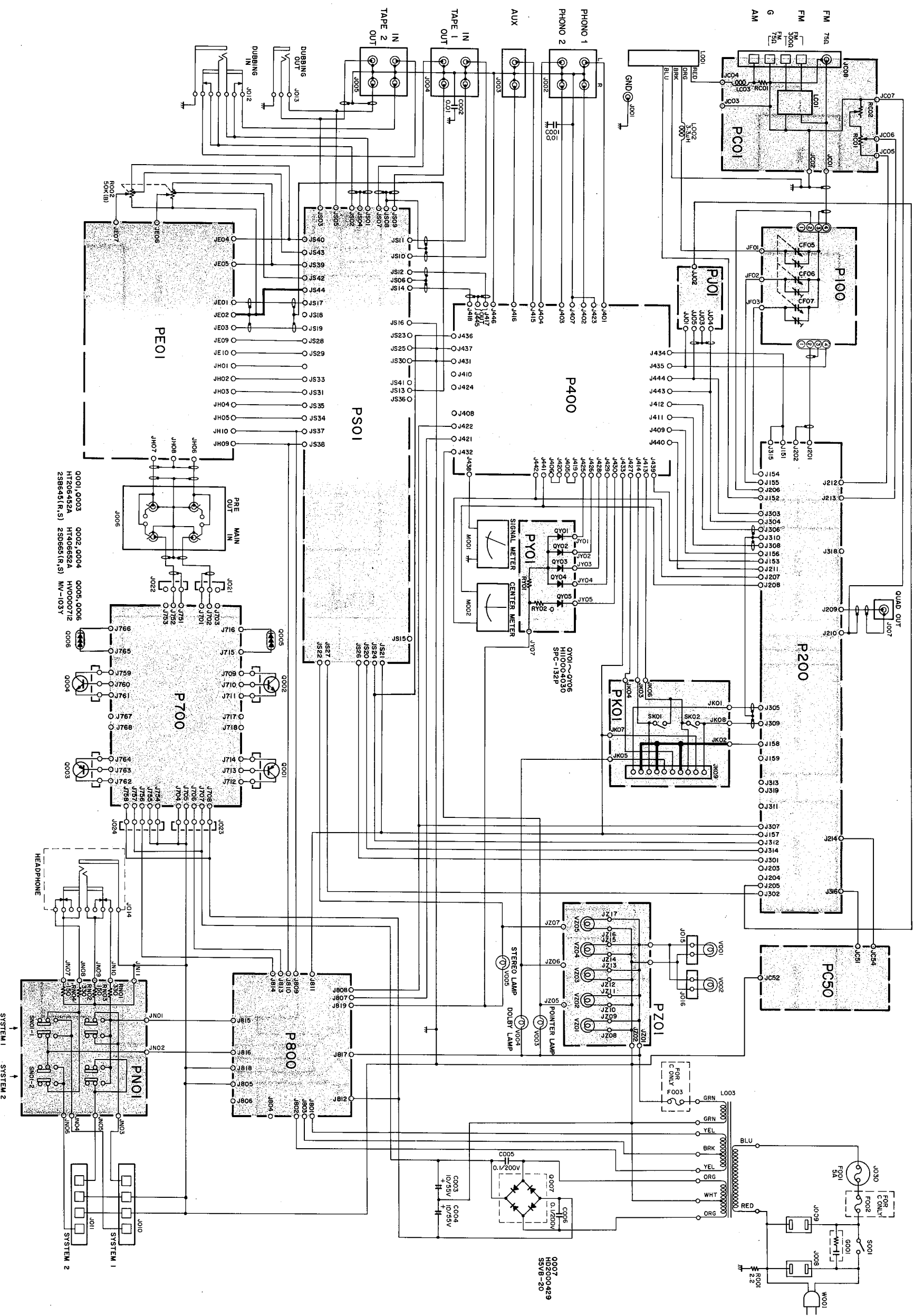

Figure 2. Dial Stringing

7. DIAGRAMS
7.1 BLOCK DIAGRAM





7.3 CONNECTION DIAGRAM - EUROPE

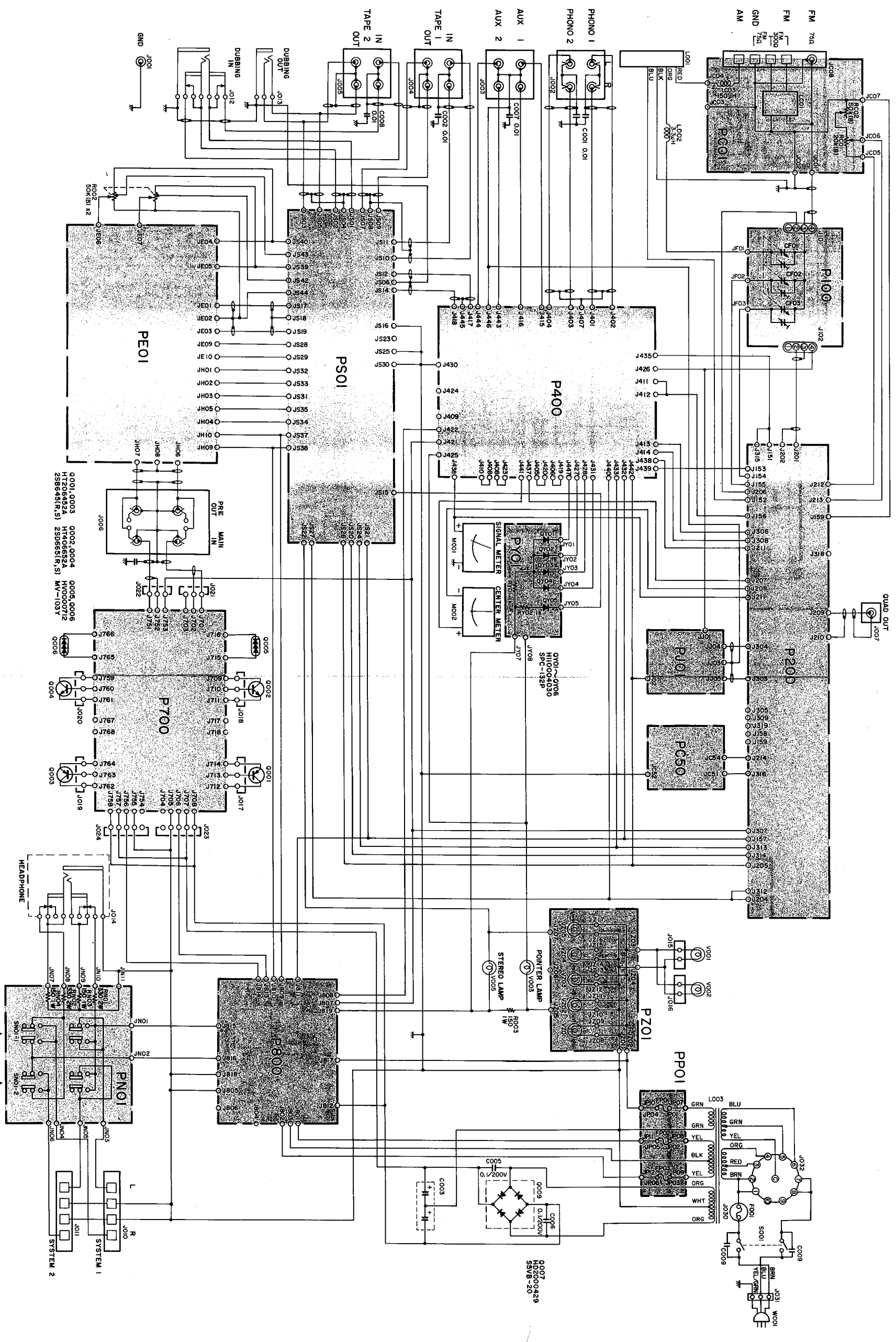

8. SCHEMATIC DIAGRAMS AND COMPONENT LOCATIONS
8.1 FM FRONT END CIRCUIT BOARD P100

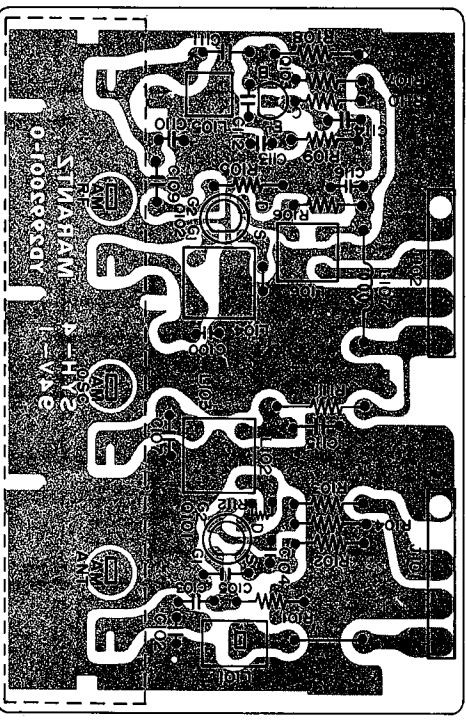
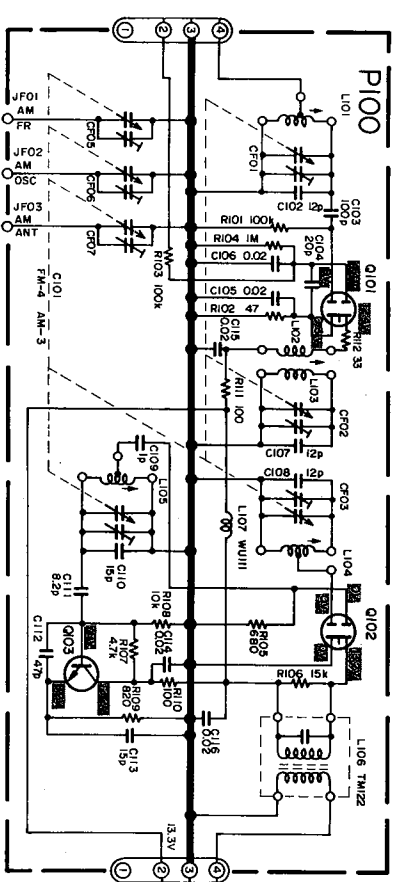

8.2 AM TUNER, FM IF & MPX DECODER CIRCUIT BOARD P200

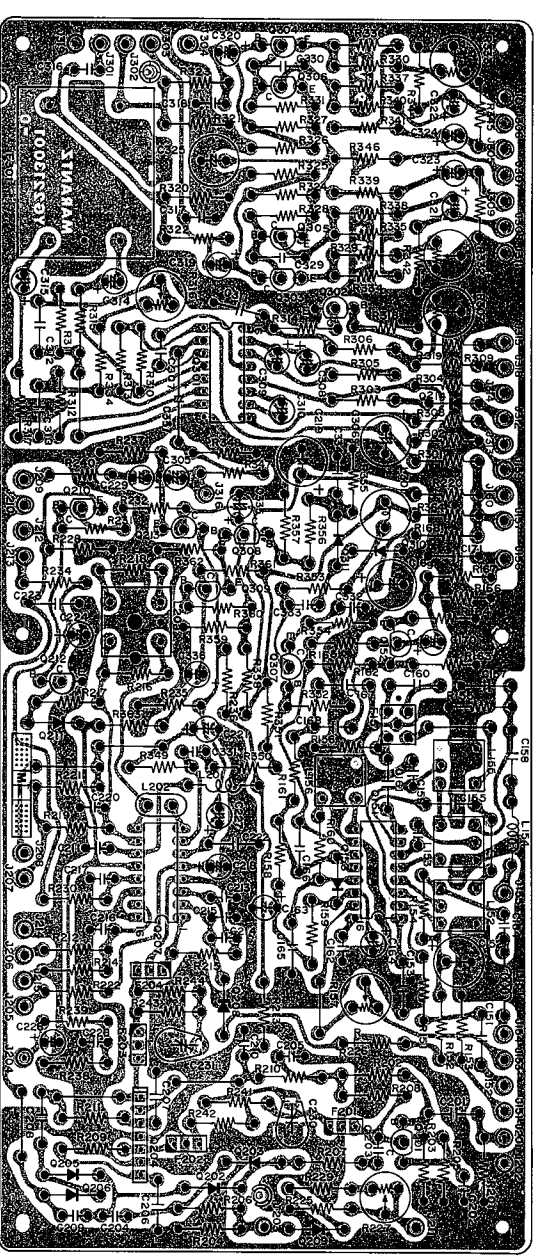
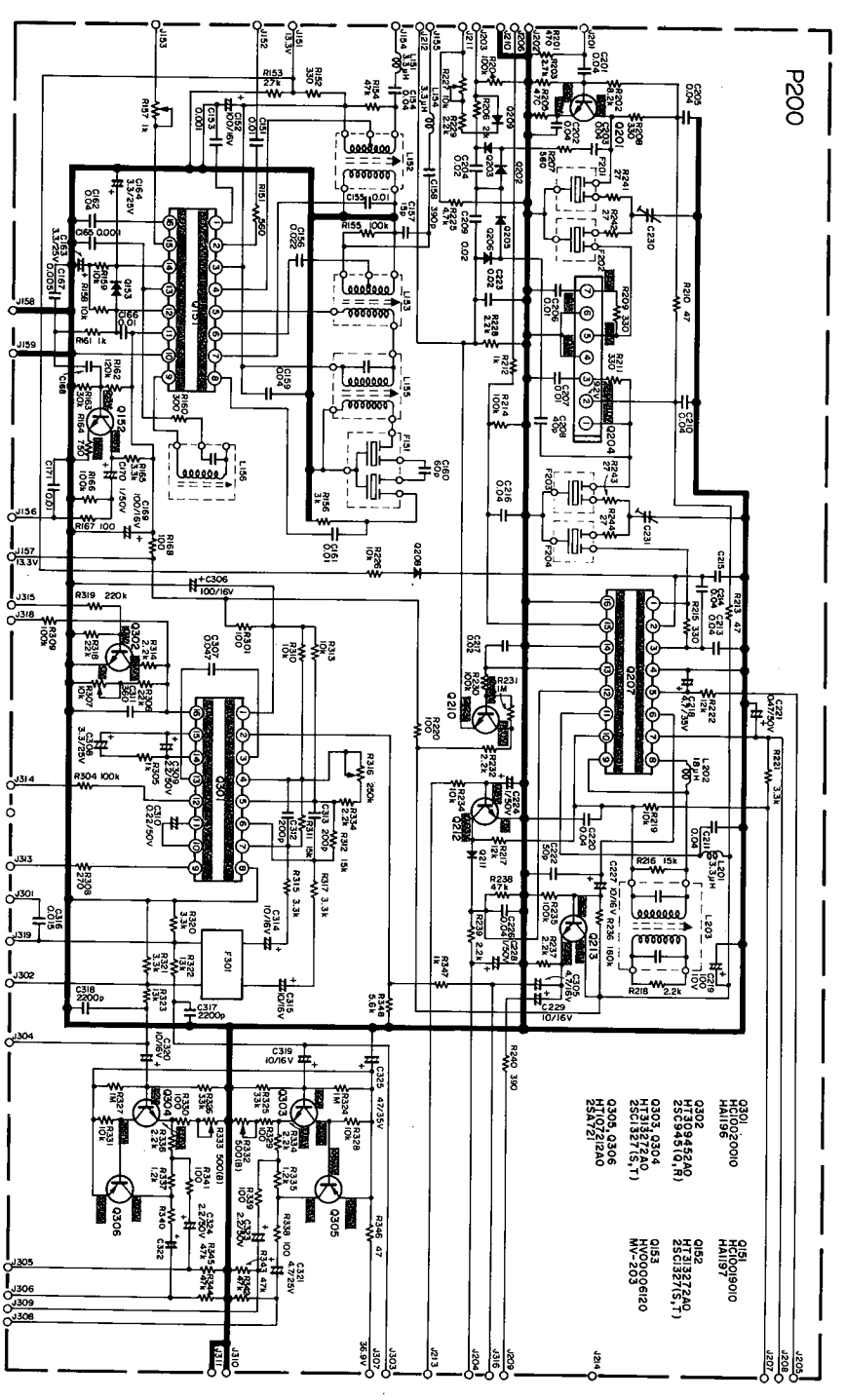

8.3 PHONO AMP CIRCUIT BOARD P400

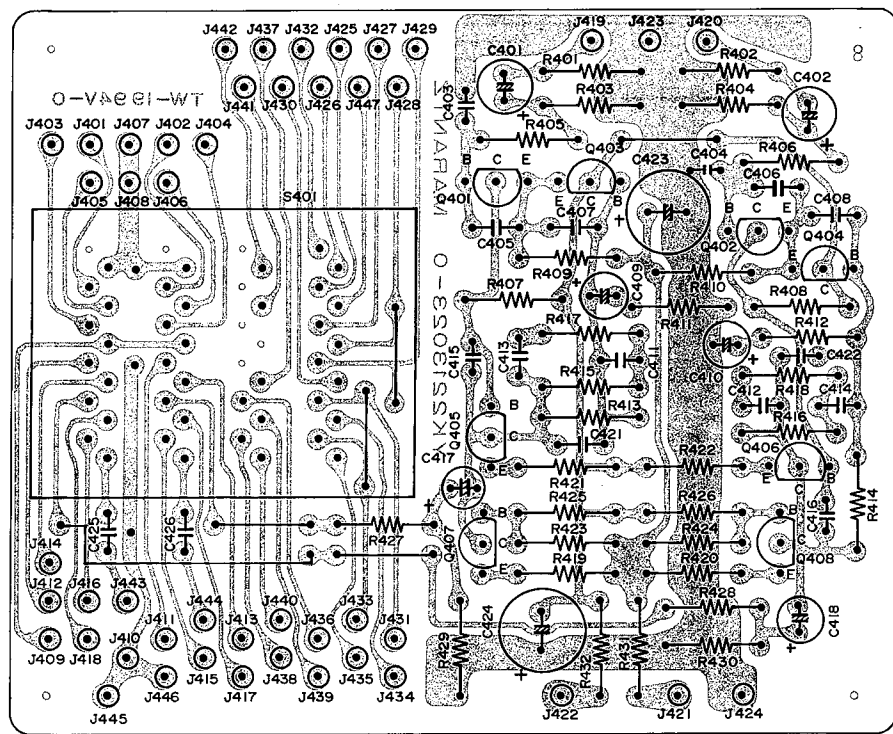
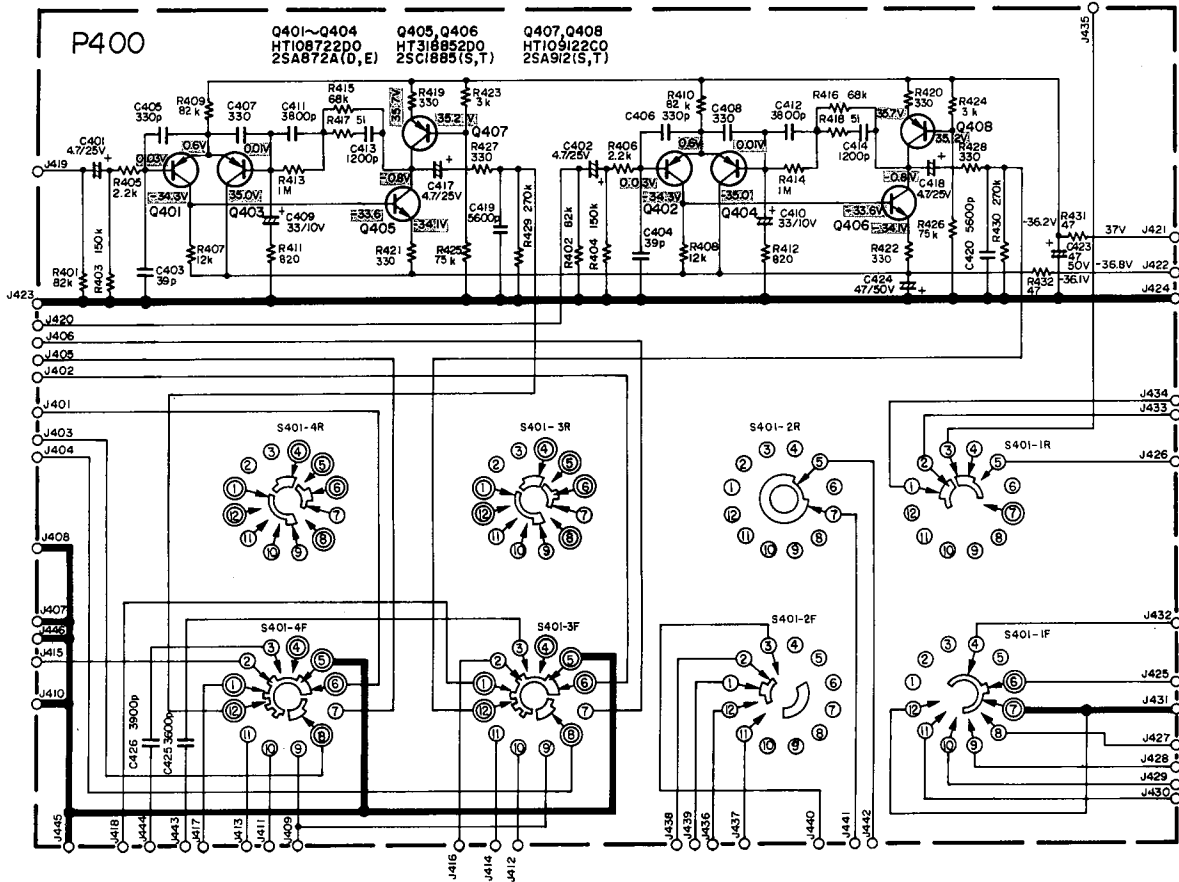

8.4 MAIN AMP CIRCUIT BOARD P700

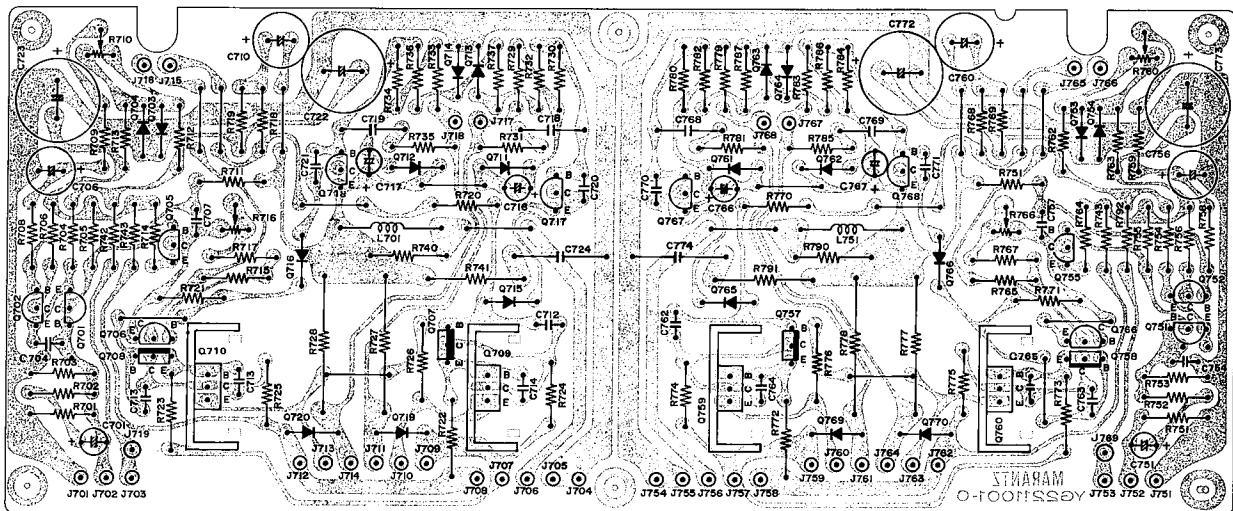
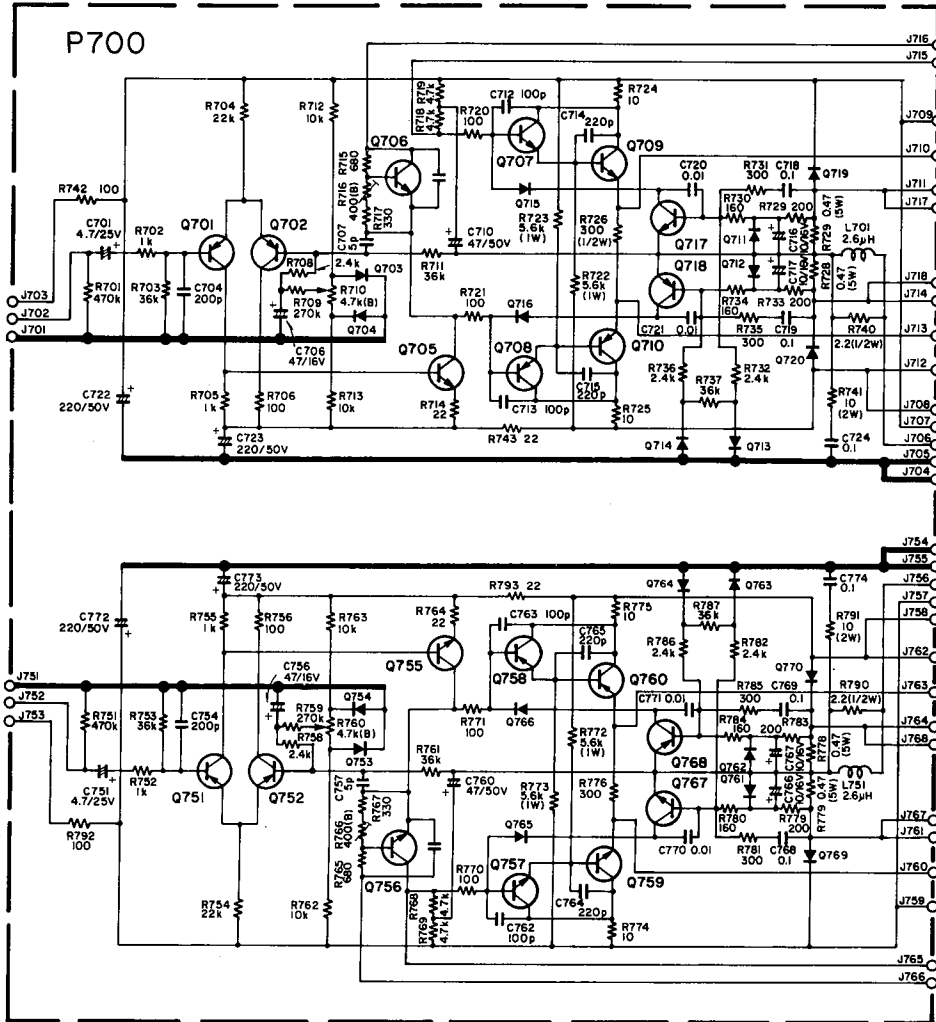

8.5 POWER SUPPLY CIRCUIT BOARD P800

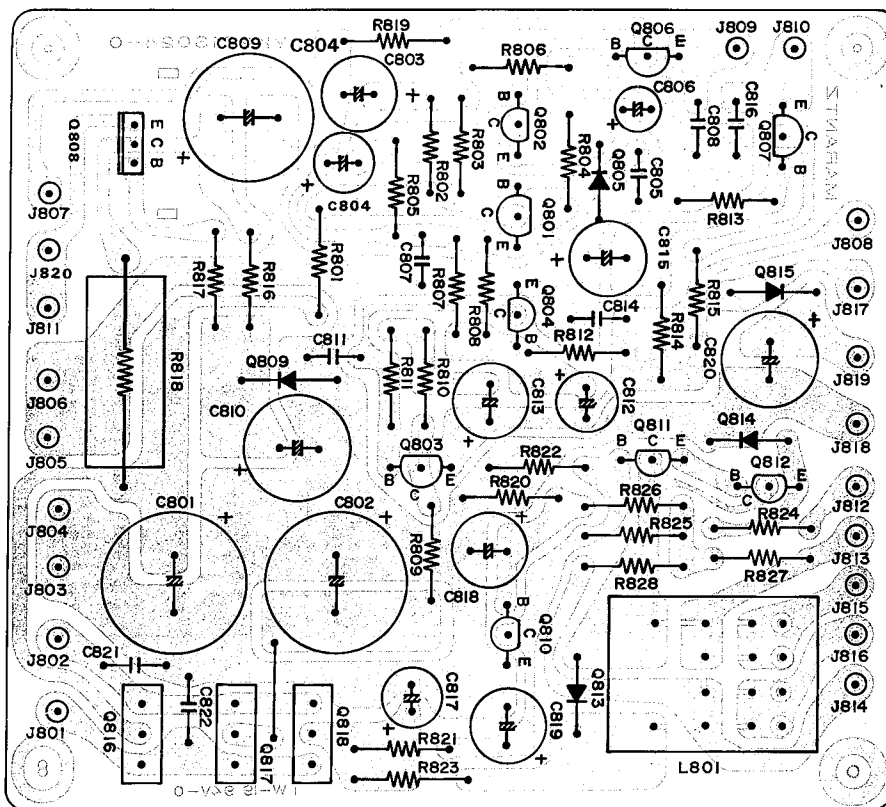
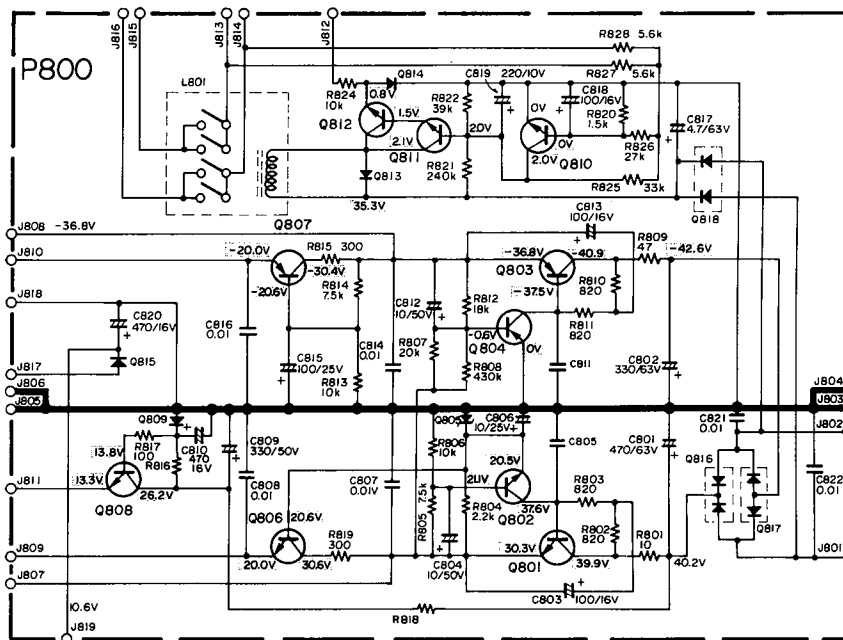

8.6 PRE AND TONE AMP CIRCUIT BOARD PE01

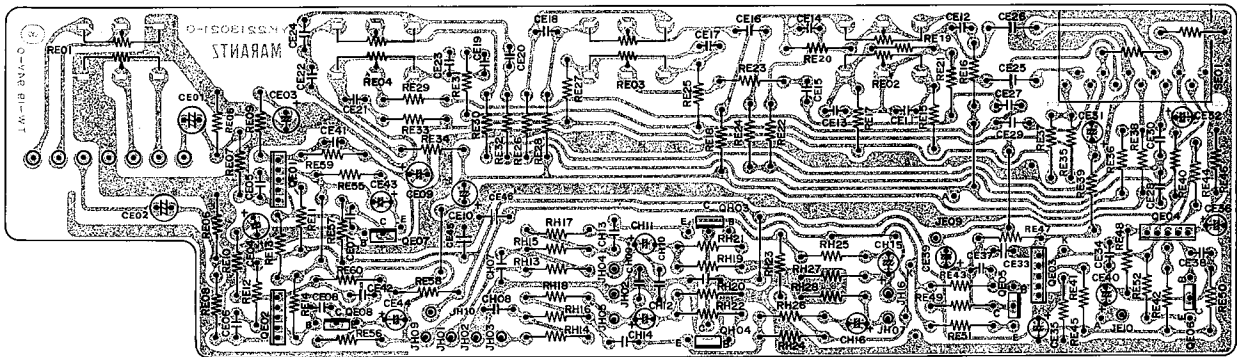
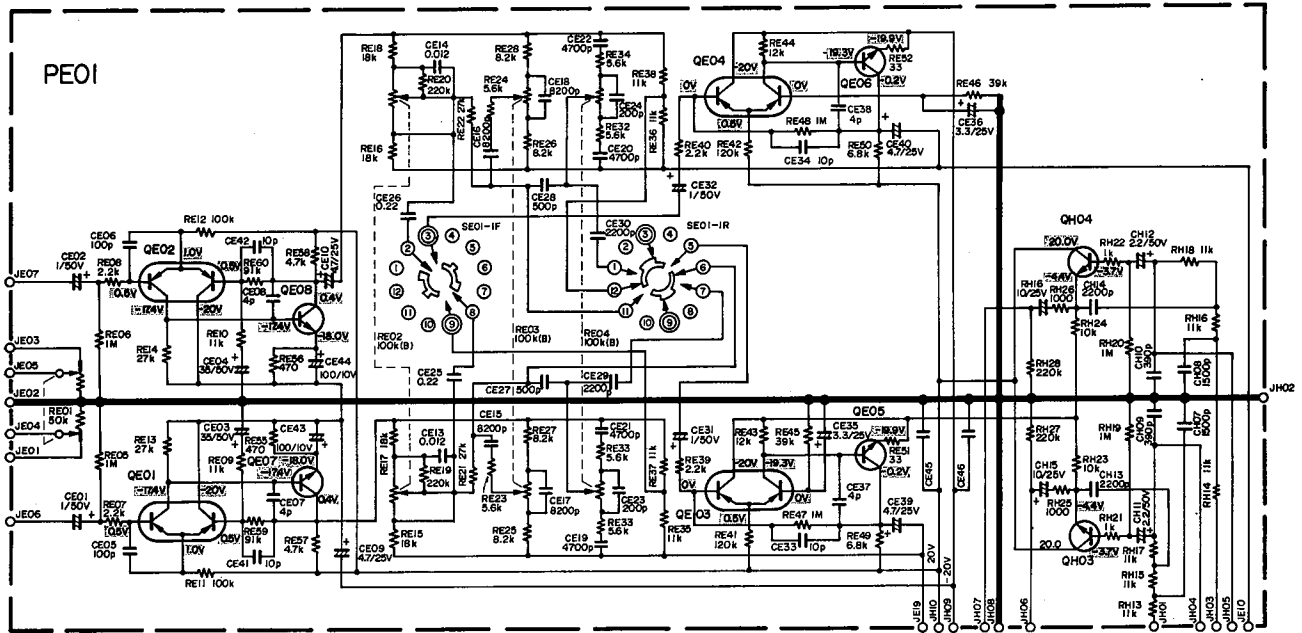

8.7 MONITOR AND FILTER SWITCHES CIRCUIT BOARD PS01

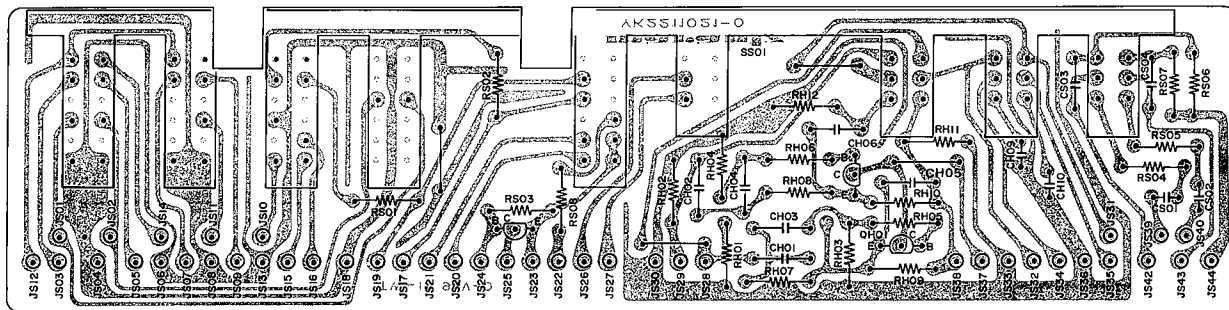
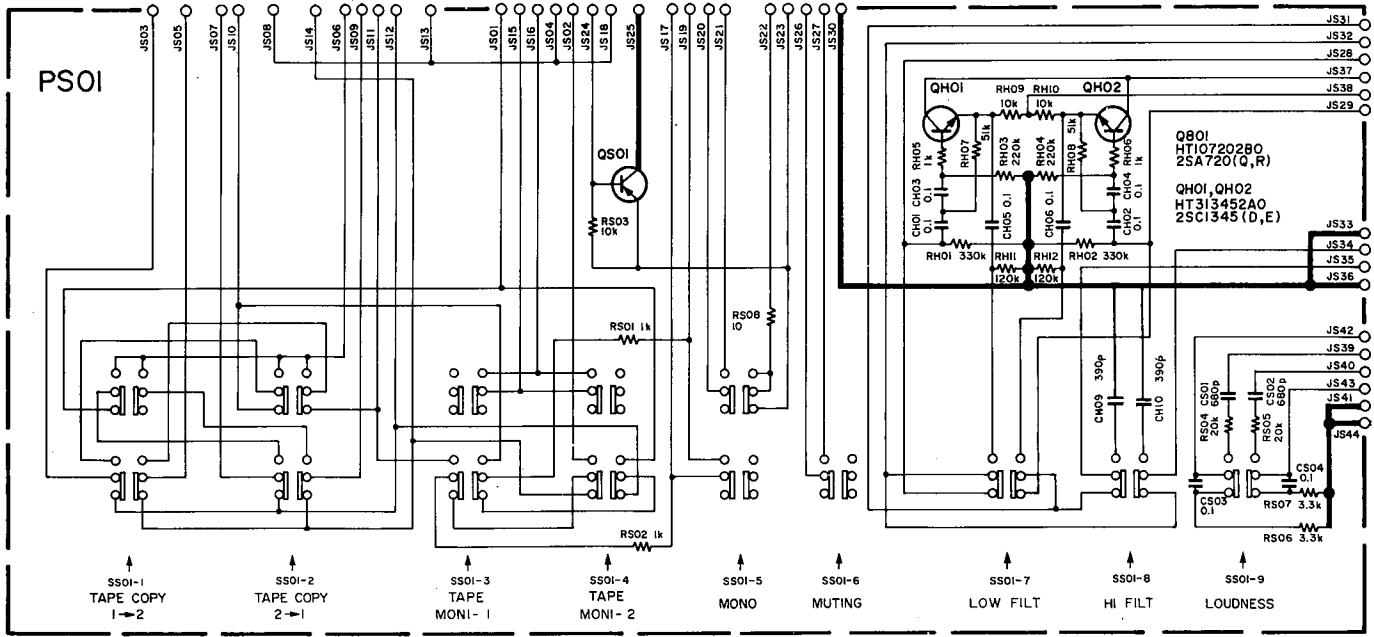

8.8 DOLBY SOCKET CIRCUIT BOARD PK01

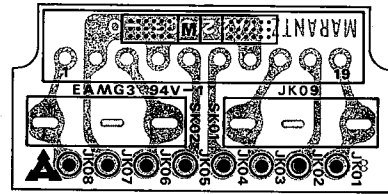
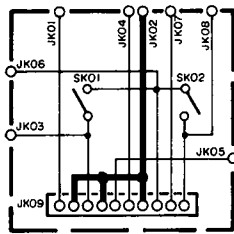

8.9 FUNCTION LAMP CIRCUIT BOARD PY01

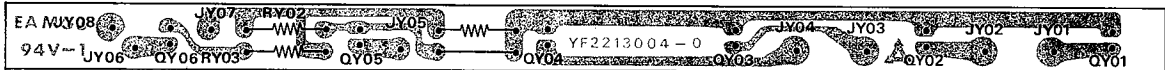
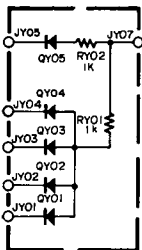

8.10 DIAL LAMP CIRCUIT BOARD PZ01

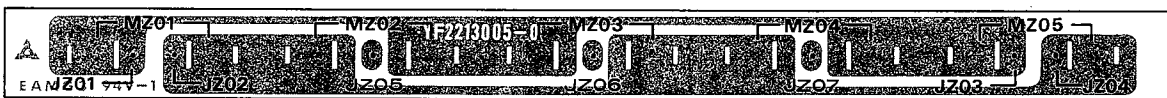
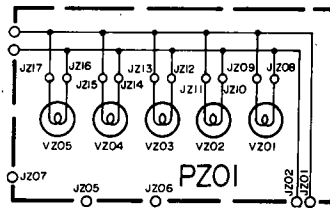

8.11 ANTENNA MUTING CIRCUIT BOARD PC01

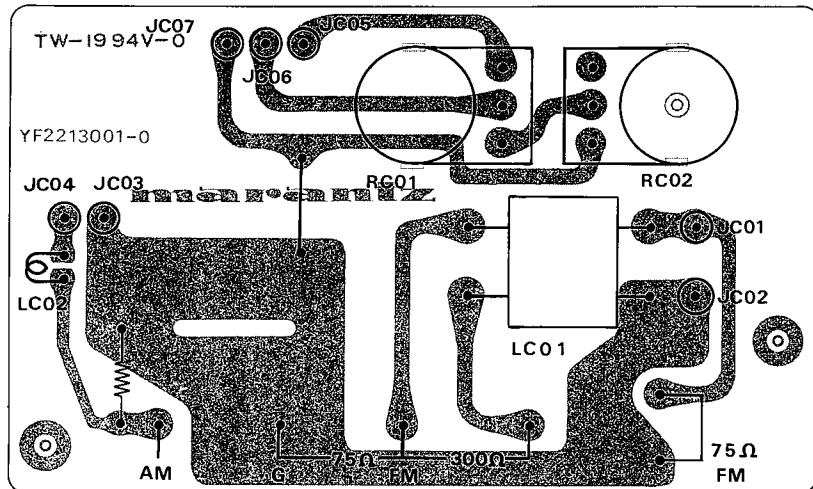
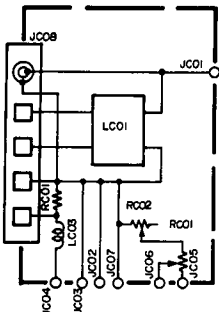

8.12 SPEAKER SWITCHES CIRCUIT BOARD PNO1

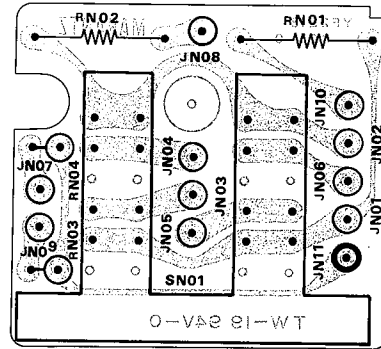
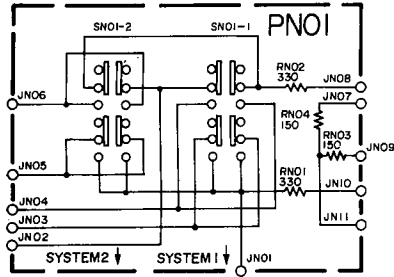

9. MAJOR COMPONENT LOCATIONS

9.1 CABINET - FRONT VIEW

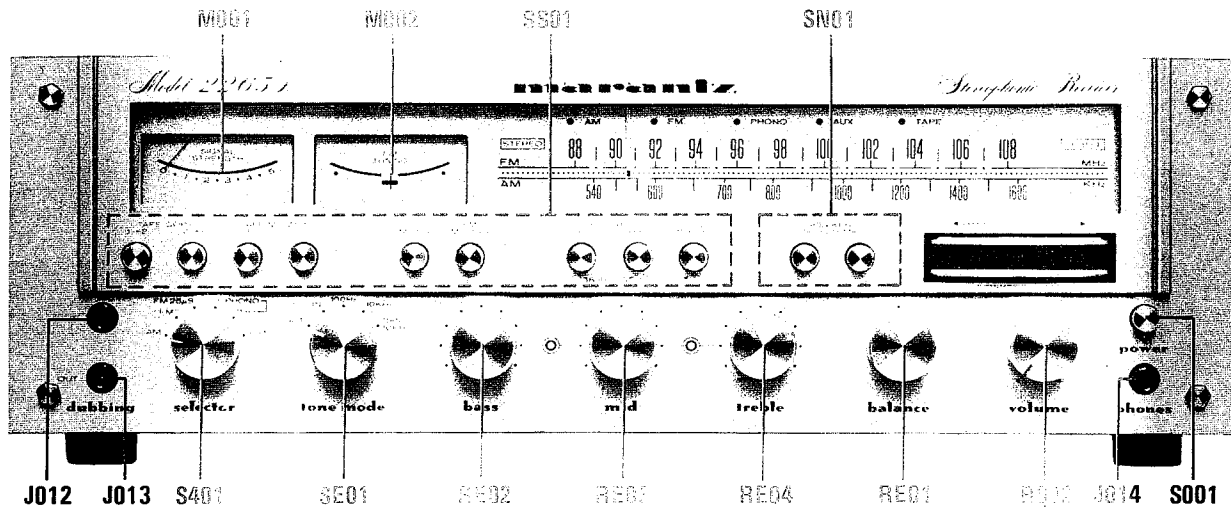

9.2 CHASSIS - TOP VIEW

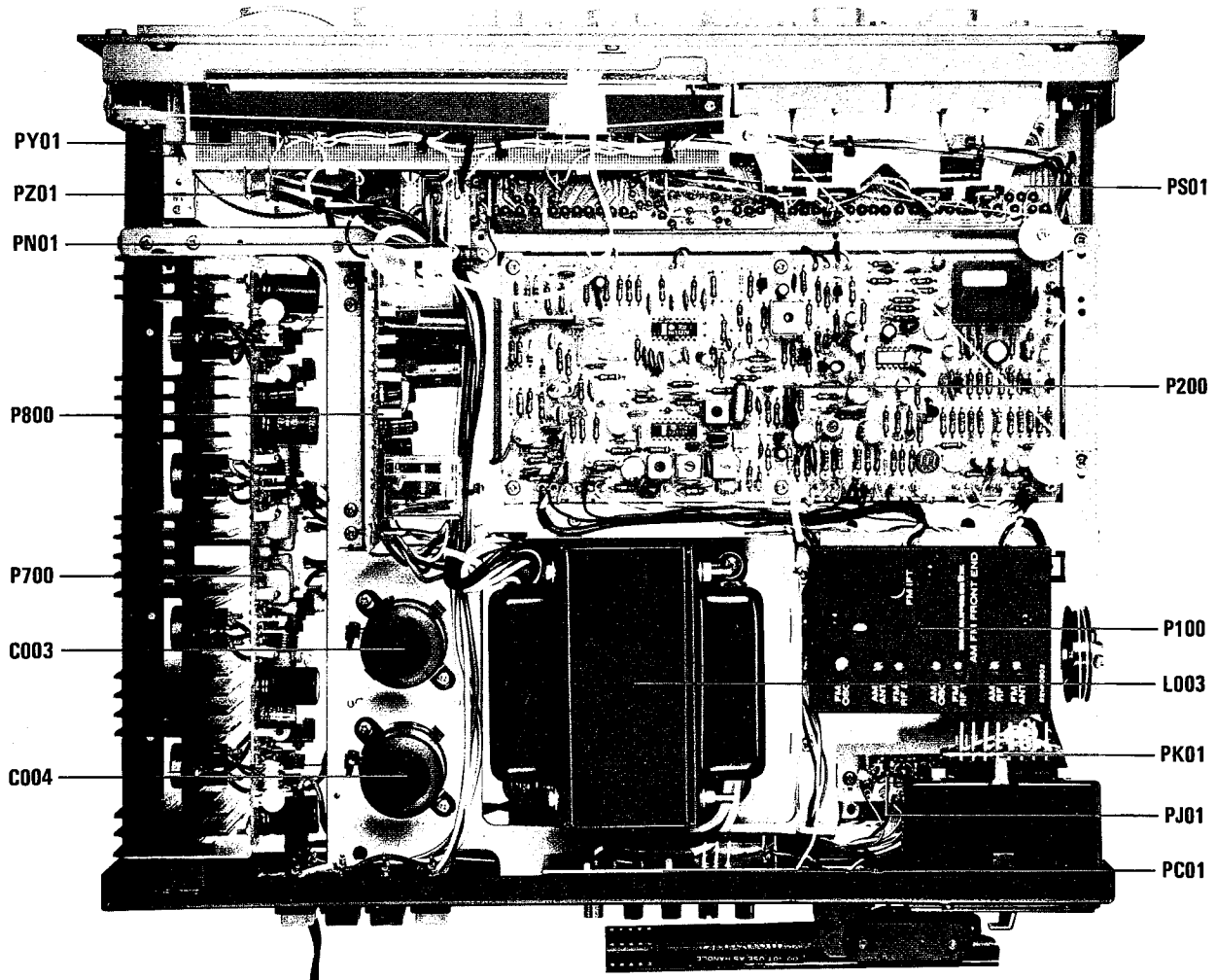

9.3 CABINET - REAR VIEW

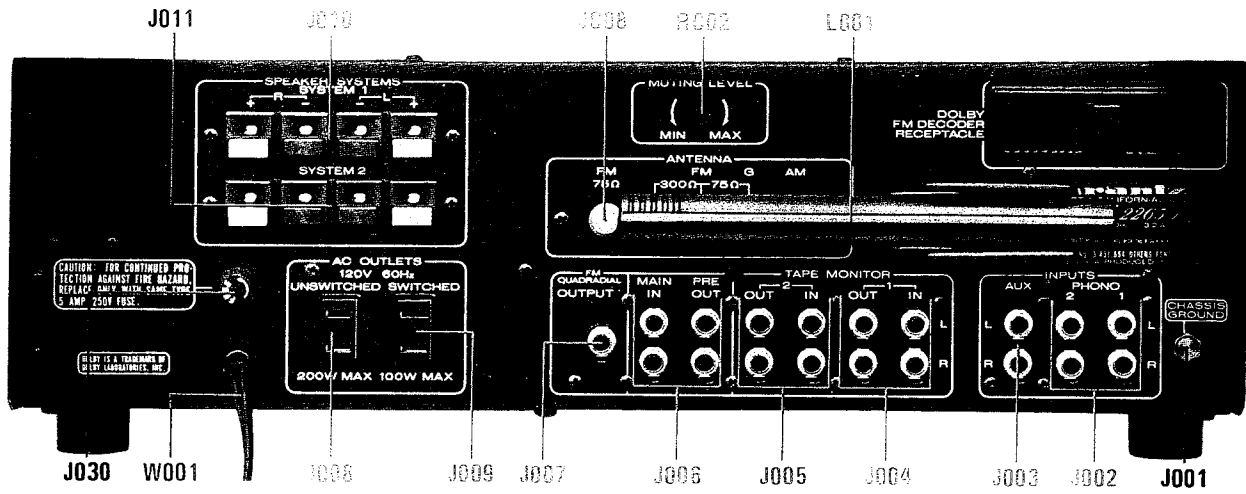

9.4 CHASSIS - BOTTOM VIEW

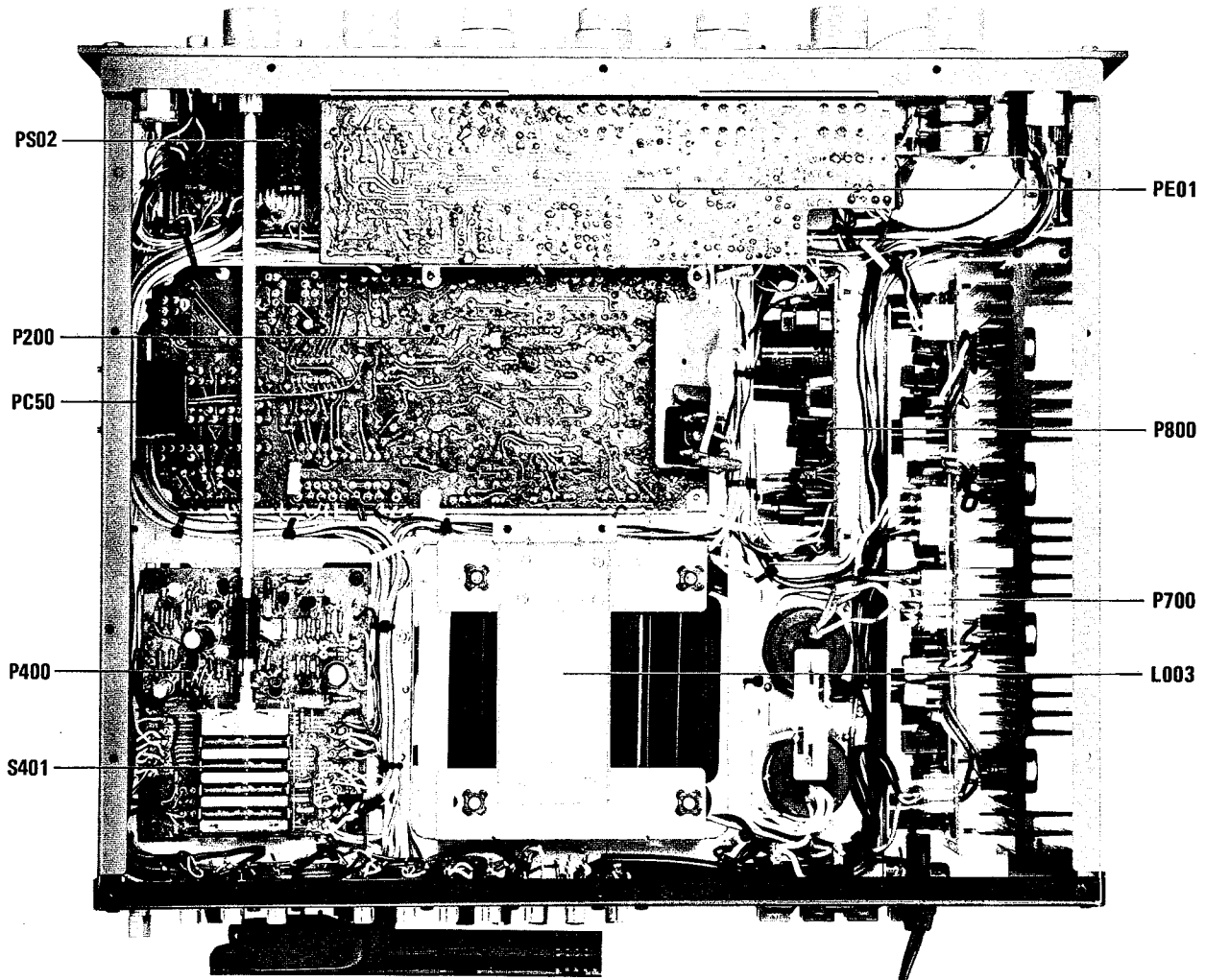

10. EXPLODED VIEWS

10.1 REAR PANEL EXPLODED VIEW - U.S.A. & CANADA

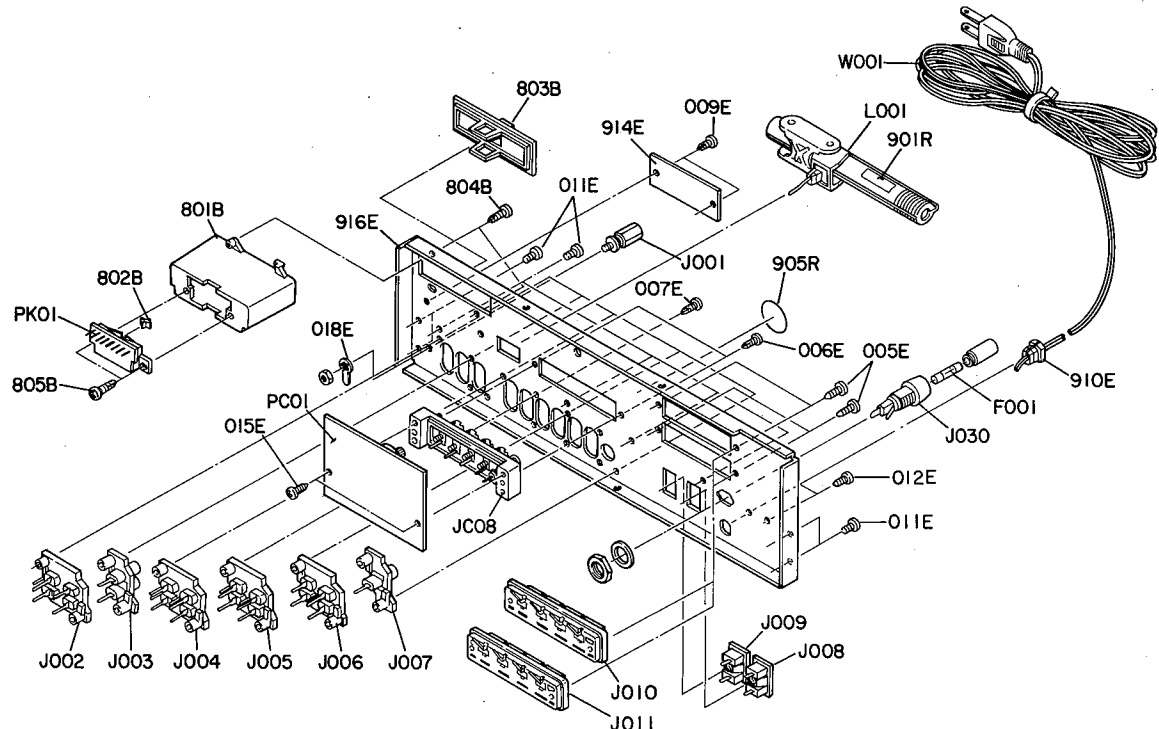

10.2 REAR PANEL EXPLODED VIEW - EUROPE

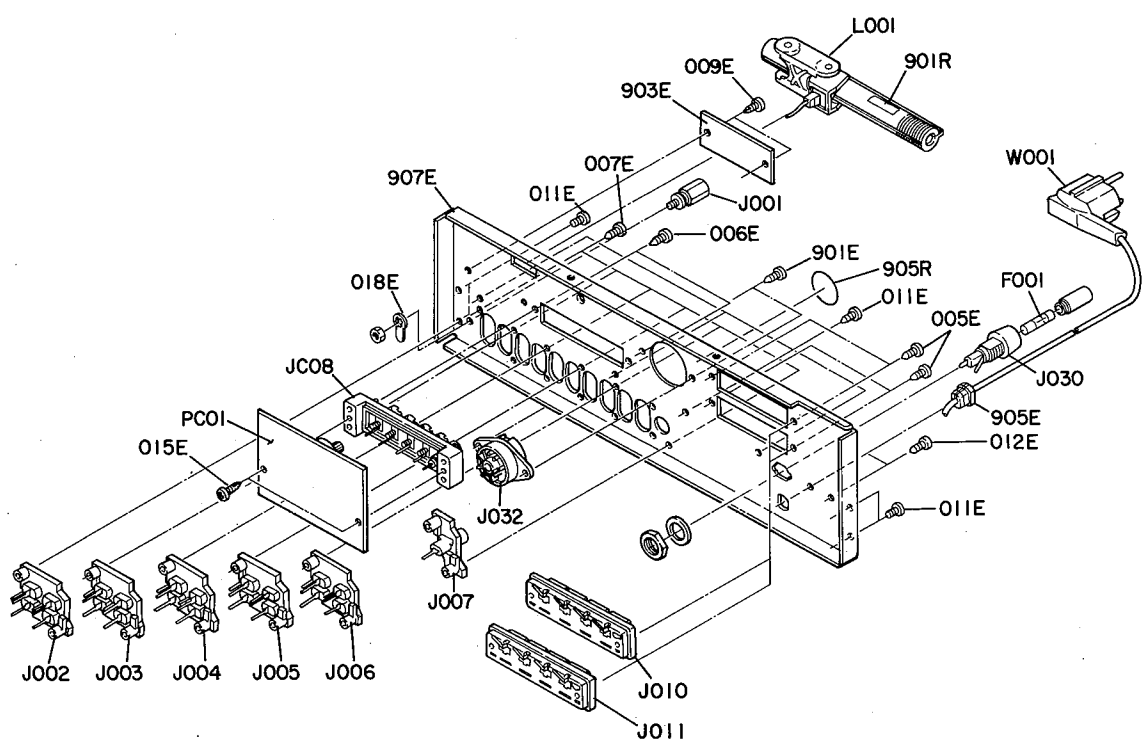

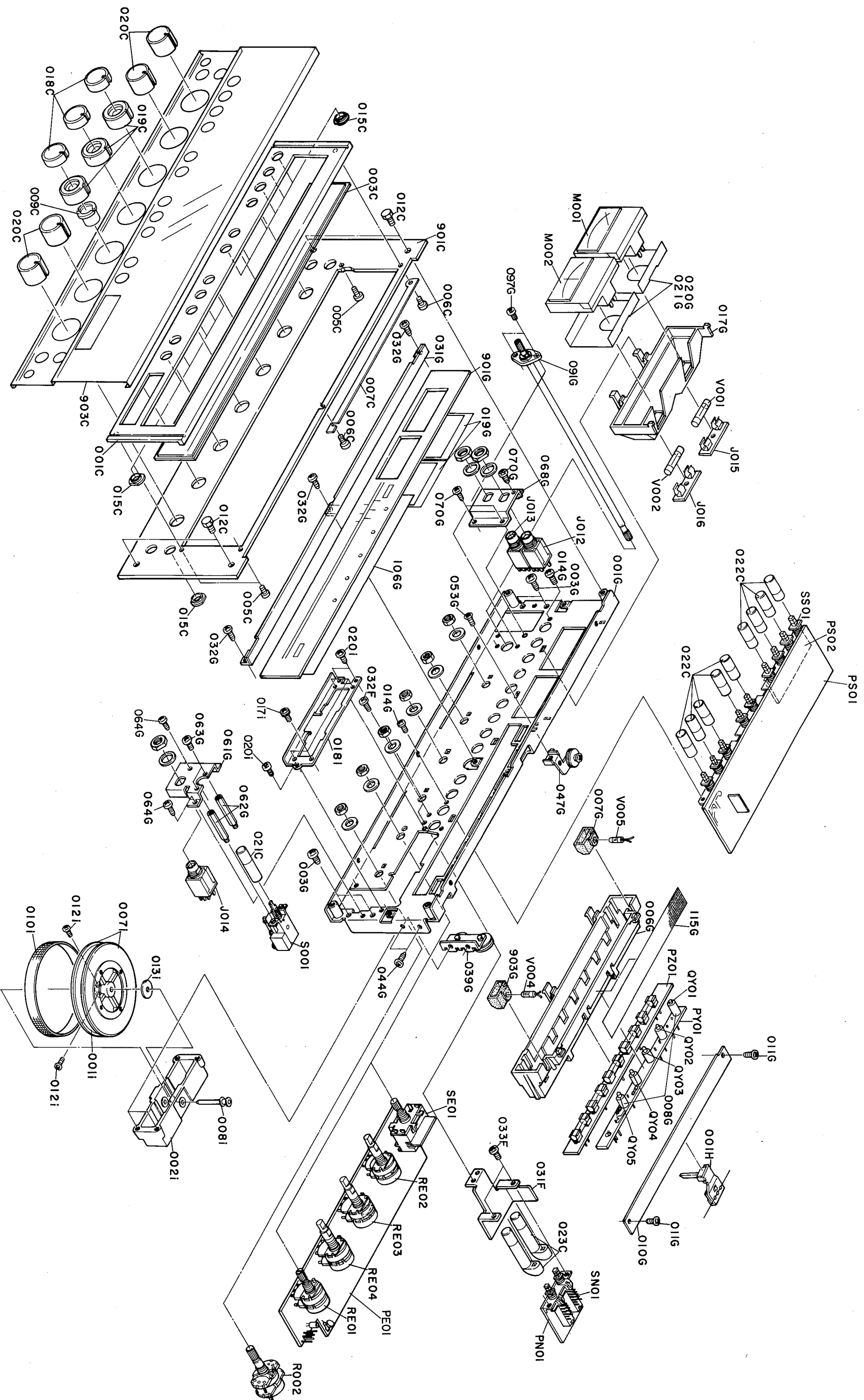

10.5 PACKING MATERIAL EXPLODED VIEW

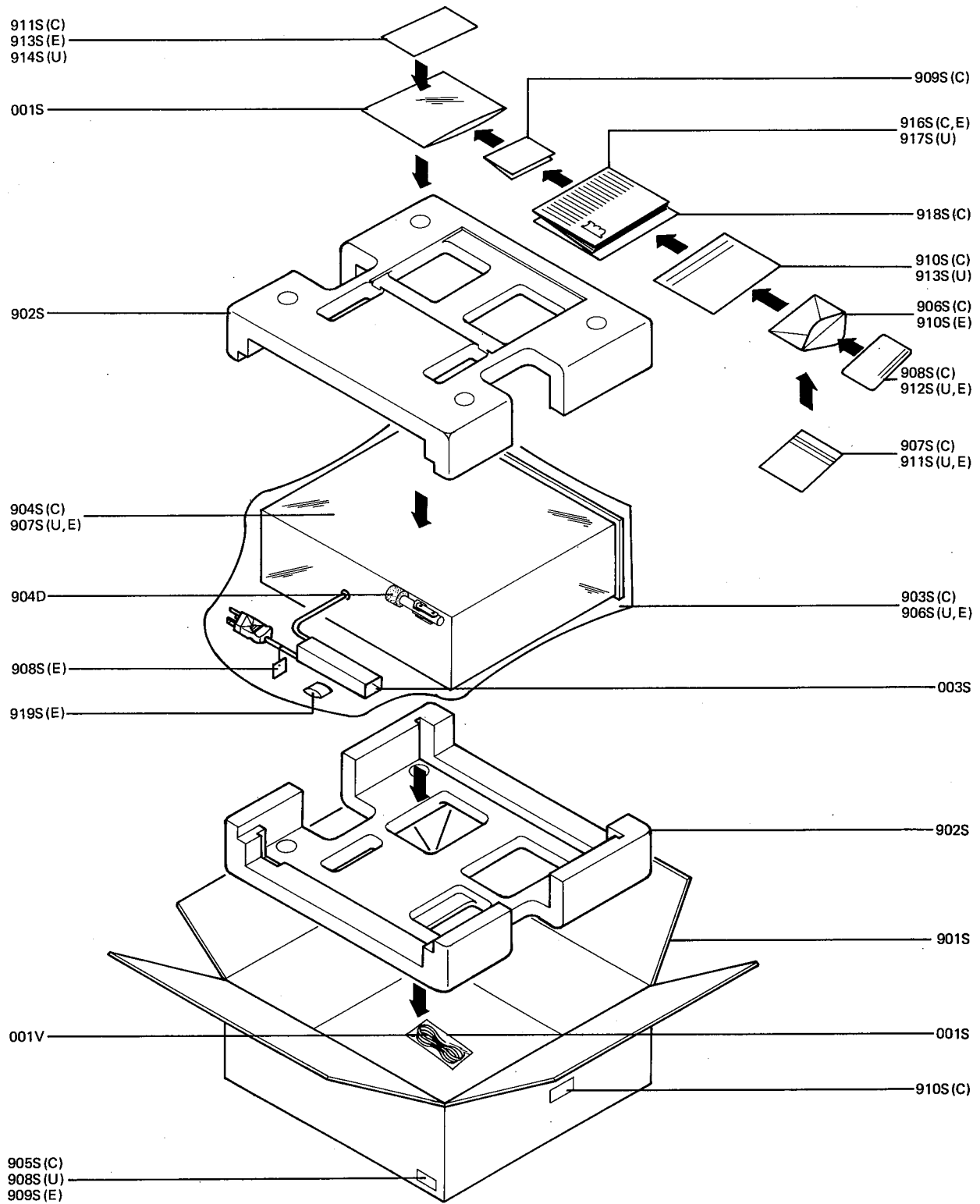

U: For U.S.A.
 C: For Canada
 E: For Europe

U: For U.S.A.
C: For Canada
E: For Europe

11. PARTS LIST

REF. DESIG.	Q'TY			PART NO.	DESCRIPTION
	U	C	E		
A	1	1		2211063400	Front Panel Assembly
A1			1	2211063410	Front Panel Assembly
001C	1	1	1	2211063012	Escutcheon
003C	1	1	1	2211158110	Window
005C	5	5	5	51100305A9	B.H.M. Screw, B3x5
015C	12	12	12	2978259010	Bushing
901C	1	1		2213063013	Escutcheon
901C			1	2213063113	Escutcheon
903C	1	1	1	2213053012	Cover
B	1	1	1	2219273410	Flywheel Assembly
0011	1	1	1	2219273010	Flywheel
0071	2	2	2	2219063030	Escutcheon
0101	1	1	1	2215353010	Ring
0121	1	1	1	51820206B0	P.H.M. Screw, P2x6
C	1	1	1	2204159400	Drum Assembly
161F	1	1	1	2204159010	Drum
162F	1	1	1	71101689L0	Spring
163F	2	2	2	51064019A9	P.H.M. Screw, P4x19
D	1	1	1	1202006430	Hook Assembly
168F	1	1	1	1202258010	Hook
170F	2	2	2	72071605A0	String
MECHANICAL PARTS					
PC11	1	1	1	75061251P0	Jumper
PE11	5	5	5	75061251P0	Jumper
PE12	1	1	1	75061501P0	Jumper
PS11	6	6	6	75061251P0	Jumper
P208	10	10	10	2933118020	Spacer
P211	8	8	8	75061001P0	Jumper
P212	5	5	5	75061251P0	Jumper
P213	1	1	1	75062001P0	Jumper
P411	5	5	5	75061251P0	Jumper
P412			2	75060501P0	Jumper
P707	28	28	28	3444118050	Spacer
P708	12	12	12	2933118020	Spacer
P711	17	17	17	75061251P0	Jumper
P807	4	4	4	3444118050	Spacer
P808	13	13	13	2933118020	Spacer
P809	2	2	2	2933118010	Spacer
P811	2	2	2	75061251P0	Jumper
P335			1	75061251P0	Jumper
P337			1	75061251P0	Jumper
001D	1	1	1	2213257020	Lid
001F	1	1	1	2211105014	Chassis
001G	1	1	1	2211160043	Bracket
001H	1	1	1	2991103500	Pointer
001K	1	1	1	2210109020	Shield
001S	1	1	1	9013025010	Polyethylene Bag
001V	1	1	1	ZA02000070	External Antenna, FM
002D	12	12	12	51280406U0	B.H. Tapped Screw, B4x6ST
002E	1	1	1	2218271070	Holder
002H	1	1	1	2991103010	Pointer
002I	1	1	1	2213104500	Retainer

REF. DESIG.	Q'TY			PART NO.	DESCRIPTION
	U	C	E		
002K	2	2	2	51060303B9	P.H.M. Screw, P3x3
003F	1	1	1	2213126013	Stay
003G	4	4	4	51280408B0	B.H. Tapped Screw, B4x8ST
003H	1	1	1	2818103010	Pointer
003I	1	1	1	2213104010	Retainer
003K	2	2	2	2210109030	Shield
003S	1	1	1	2864804010	Sleeve
004F	1	1	1	2213126023	Stay
004K	1	1	1	2210109040	Shield
005E	4	4	4	51280308U0	B.H. Tapped Screw, B3x8ST
005H	1	1	1	2218152010	Tube
005K	4	4	4	51060303B9	P.H.M. Screw, P3x3
006E	2	2	2	51280308U0	B.H. Tapped Screw, B3x8ST
006F	4	4	4	51280308B0	B.H. Tapped Screw, B3x8ST
006G	1	1	1	2211274102	Reflector
006H	1	1	1	2218280010	Housing
007E	12	12	12	51280308U0	B.H. Tapped Screw, B3x8ST
007G	1	1	1	2211274302	Reflector
008G	5	5	5	2211118010	Spacer
008I	1	1	1	2219112010	Shaft
009C	1	1	1	2213055010	Coilar
009E	2	2	2	51760306B0	OS Tapped Screw, 3x6
009F	6	6	6	51280306B0	B.H. Tapped Screw, B3x6ST
010F	1	1	1	2992109020	Shield
010G	1	1	1	2205051013	Guide
011E	8	8	8	51280308U0	B.H. Tapped Screw, B3x8ST
011F	1	1	1	62030039W0	Lug
011G	2	2	2	51280306B0	B.H. Tapped Screw, B3x6ST
012C	4	4	4	52017069J0	H. Head Bolt
012E	2	2	2	51280308U0	B.H. Tapped Screw, B3x8ST
012F	1	1	1	3918109010	Shield
013I	1	1	1	59031405G9	Washer
014G	2	2	2	51100306A9	B.H.M. Screw, B3x6
015E	2	2	2	51280308U0	B.H. Tapped Screw, B3x8ST
016F	3	3	3	51280306B0	B.H. Tapped Screw, B3x6ST
017F	1	1	1	2214109032	Shield
017G	1	1	1	2211274203	Reflector
017I	4	4	4	51470306A9	L. Washer Screw, 3x6
018C	3	3	3	2210154210	Knob
018E	1	1	1	62040029W0	Lug
018F	3	3	3	51100306S9	B.H.M. Screw, B3x6
018I	1	1	1	2205160123	Bracket
019C	3	3	3	2210154220	Knob
019G	2	2	2	2213053022	Cover
020C	4	4	4	2221154230	Knob
020G	1	1	1	2991107020	Sheet
020I	3	3	3	51280306B0	B.H. Tapped Screw, B3x6ST
021C	1	1	1	2209154010	Knob
021G	1	1	1	2991107020	Sheet
022C	9	9	9	2205154030	Knob
022F	4	4	4	51490514A9	L. Washer Screw, 5x14
023C	2	2	2	2211154010	Knob
031F	1	1	1	2213160113	Bracket
031G	1	1	1	2205269013	Protector
032F	2	2	2	51280306B0	B.H. Tapped Screw, B3x6ST
032G	3	3	3	51280306B0	B.H. Tapped Screw, B3x6ST
033F	2	2	2	51100306A9	B.H.M. Screw, B3x6
037F	1	1	1	2213160132	Bracket
038F	1	1	1	2213160142	Bracket
039F	4	4	4	51280308B0	B.H. Tapped Screw, B3x8ST
039G	1	1	1	2205262512	Pulley

U: For U.S.A.
 C: For Canada
 E: For Europe

REF. DESIG.	Q'TY			PART NO.	DESCRIPTION
	U	C	E		
040F	4	4	4	51280308B0	B.H. Tapped Screw, B3x8ST
041F	1	1	1	2963267020	Heatsink
042F	1	1	1	51280308B0	B.H. Tapped Screw, B 3x8 ST
044G	2	2	2	51280306B0	B.H. Tapped Screw, B3x6ST
047G	1	1	1	2213262512	Pulley
049F	4	4	4	51280308B0	B.H. Tapped Screw, B3x8ST
050F	1	1	1	2213123010	Contacto
051F	2	2	2	51280306B0	B.H. Tapped Screw, B3x6ST
053G	1	1	1	51042608A0	F.H.M. Screw, F2.6x8
061F	1	1	1	2211267010	Heatsink
061G	1	1	1	2213160020	Bracket
062G	2	2	2	2213101010	Support
063F	1	1	1	2211160010	Bracket
063G	2	2	2	51100306A9	B.H.M. Screw, B3x6
064F	1	1	1	2211160020	Bracket
064G	2	2	2	51280306B0	B.H. Tapped Screw, B3x6ST
065F	1	1	1	2211160030	Bracket
068F	6	6	6	51280306B0	B.H. Tapped Screw, B3x6ST
068G	1	1	1	2213160030	Bracket
070F	6	6	6	51280306B0	B.H. Tapped Screw, B3x6ST
070G	3	3	3	51280306B0	B.H. Tapped Screw, B3x6ST
076F	8	8	8	51100316E9	B.H.M. Screw, B3x16
077F	4	4	4	2577118020	Spacer
078F	4	4	4	2963267020	Heatsink
079F	4	4	4	51280308B0	B.H. Tapped Screw, B3x8ST
083F	2	2	2	51280312B0	B.H. Tapped Screw, B3x12ST
091F	4	4	4	51280306B0	B.H. Tapped Screw, B3x6ST
091G	1	1	1	2213112504	Shaft
094F	1	1	1	51280312B0	B.H. Tapped Screw, B3x12ST
097F	1	1	1	62030039W0	Lug
097G	2	2	2	51280308B0	B.H. Tapped Screw, B3x8ST
098F	1	1	1	62030039W0	Lug
100F	1	1	1	2963125010	Joint
103F	9	9	9	2886005040	Clamper
104F	1	1	1	2886005060	Clamper
106G	1	1	1	2213107010	Sheet
131F	1	1	1	2213262500	Pulley
136F	1	1	1	51280306B0	B.H. Tapped Screw, B3x6ST
140F	1	1	1	2213262520	Pulley
145F	1	1	1	51280306B0	B.H. Tapped Screw, B3x6ST
173F	1	1	1	56382540G0	Eyelet
801B	1	1	1	2218271050	Holder
802B	1	1	1	2218258010	Hook
803B	1	1	1	2218257030	Lid
804B	2	2	2	51280308U0	B.H. Tapped Screw, B3x8ST
805B	2	2	2	51280308U0	B.H. Tapped Screw, B3x8ST
901D	1	1	1	2213257010	Lid
901E			2	51100308S9	B.H.M. Screw, B3x8
901F			1	2213160150	Bracket
901G	1	1		2211302013	Dial
901G			1	2211302023	Dial
901R	1	1	1	2506265060	Indicator
901R		1		2911861170	Label
901S	1	1	1	2211801010	Packing Case
902D	4	4	4	51280306U0	B.H. Tapped Screw, B3x6ST
902F			2	51280306B0	B.H. Tapped Screw, B3x6ST
902G			4	2970120030	Insulator
902R	1		1	2578861010	Label
902R		1		2911861112	Label
902S	2	2	2	2204809012	Cushion
903D	4	4	4	51480406S9	F. Washer Screw, 4x6

REF. DESIG.	Q'TY			PART NO.	DESCRIPTION
	U	C	E		
903E			1	2211265030	Indicator
903G	1	1	1	2211274302	Reflector
903R	1		1	2932861010	Label
903R		1		9510601050	Label
903S		1		9014838380	Polyethylene Bag
904D	1	1	1	2917056012	Buffer
904R			1	2882861020	Label
904R		1		2911861162	Label
904R	1			9510911020	Label
904S		1		2918107130	Sheet
905E			1	1455259050	Bushing
905F			2	51280314B0	B.H. Tapped Screw, B3x14ST
905R		1		2911861142	Label
905R	1			9511101020	Label
905S		3		9523015120	Serial No. Card
906F			1	4113120010	Insulator
906R		1		9510911010	Label
906S		1		2918813012	Envelope
906S	1		1	9014838380	Polyethylene Bag
907E		1		2211160220	Bracket
907S		1		2818851120	Instructions
907S	1		1	2918107130	Sheet
908R		1		2911861012	Label
908S	3			9522815010	Serial No. Card
908S		1		9560000042	Hang Tag
908S		1		9630000180	Guarantee Card
909R		1		2911861192	Label
909S			3	9523015110	Serial No. Card
909S		1		9650000050	Service Station Card
910E	1	1		1455259030	Bushing
910R		1		2911861240	Label
910S			1	2818813010	Envelope
910S		1		2818854042	Guarantee Card
911D	4	4	4	2759057012	Leg
911S		1		2577851020	Instructions
911S			1	2818851120	Instructions
911S		1		2818854140	Guarantee Card
912D	4	4	4	51570410B0	P. Tapped Screw, 4x10
912S		1		2577854012	Guarantee Card
912S			1	9630000180	Guarantee Card
913D	4	4	4	54040402N0	Spring Washer
913S			1	2818851140	Instructions
913S	1			2818854023	Guarantee Card
914D	4	4	4	54020401E0	Flat Washer P
914E	1			2211265010	Indicator
914E		1		2211265020	Indicator
914S	1			2818851040	Instructions
916E	1	1		2211160213	Bracket
916S		1	1	2211851310	Instructions
917S	1			2211851010	Instructions
918S		1		2886851100	Instructions
919S			1	2731821010	Silicagel
JC01	1	1	1	YP10001200	Plug
JC02	1	1	1	YP10001200	Plug
JC03	1	1	1	YP10001200	Plug
JC04	1	1	1	YP10001200	Plug
ELECTRICAL PARTS					

U: For U.S.A.
C: For Canada
E: For Europe

REF. DESIG.	Q'TY			PART NO.	DESCRIPTION
	U	C	E		
JC05	1	1	1	YP10001200	Plug
JC06	1	1	1	YP10001200	Plug
JC07	1	1	1	YP10001200	Plug
JC08	1	1	1	BY04050010	Terminal
LC01	1	1	1	LB30075260	Balun Coil
LC02	1	1	1	LC11540020	Choke Coil, 150μH
PC01	1	1	1	YF22130010	P.W. Board, Antenna & Muting
	1	1	1	ZZ22131010	P.W. Board Assembly
RC01	1	1	1	RK02030322	Res., Variable, 20kΩ(B)
RC02	1	1	1	RK05030170	Res., Variable, 50kΩ(B)
CE01	1	1	1	EE10505040	Cap., Elect., 1μF, 50V
CE02	1	1	1	EE10505040	Cap., Elect., 1μF, 50V
CE03	1	1	1	EE33601040	Cap., Elect., 33μF, 10V
CE04	1	1	1	EE33601040	Cap., Elect., 33μF, 50V
CE05	1	1	1	DD16101010	Cap., Ceramic, 100pF, 50V
CE06	1	1	1	DD16101010	Cap., Ceramic, 100μF, 50V
CE07	1	1	1	DD11040010	Cap., Ceramic, 4pF, 50V
CE08	1	1	1	DD11040010	Cap., Ceramic, 4pF, 50V
CE09	1	1	1	EE47502540	Cap., Elect., 4.7μF, 25V
CE10	1	1	1	EE47502540	Cap., Elect., 4.7μF, 25V
CE11	1	1	1	DF16123010	Cap., Film, 0.012μF, 50V
CE12	1	1	1	DF16123010	Cap., Film, 0.012μF, 50V
CE13	1	1	1	DF16123010	Cap., Film, 0.012μF, 50V
CE14	1	1	1	DF16123010	Cap., Film, 0.012μF, 50V
CE15	1	1	1	DF16682010	Cap., Film, 6800pF, 50V
CE16	1	1	1	DF16682010	Cap., Film, 6800pF, 50V
CE17	1	1	1	DF16332010	Cap., Film, 3300pF, 50V
CE18	1	1	1	DF16332010	Cap., Film, 3300pF, 50V
CE19	1	1	1	DF16472010	Cap., Film, 4700pF, 50V
CE20	1	1	1	DF16472010	Cap., Film, 4700pF, 50V
CE21	1	1	1	DF16472010	Cap., Film, 4700pF, 50V
CE22	1	1	1	DF16472010	Cap., Film, 4700pF, 50V
CE23	1	1	1	DD15201010	Cap., Ceramic, 200pF, 50V
CE24	1	1	1	DD15201010	Cap., Ceramic, 200pF, 50V
CE25	1	1	1	DF17224020	Cap., Film, 0.22μF, 50V
CE26	1	1	1	DF17224020	Cap., Film, 0.22μF, 50V
CE27	1	1	1	DD16501010	Cap., Ceramic, 500pF, 50V
CE28	1	1	1	DD16501010	Cap., Ceramic, 500pF, 50V
CE29	1	1	1	DF16222010	Cap., Film, 2200pF, 50V
CE30	1	1	1	DF16222010	Cap., Film, 2200pF, 50V
CE31	1	1	1	EE10505010	Cap., Elect., 1μF, 50V
CE32	1	1	1	EE10505010	Cap., Elect., 1μF, 50V
CE33	1	1	1	DD12100010	Cap., Ceramic, 10pF, 50V
CE34	1	1	1	DD12100010	Cap., Ceramic, 10pF, 50V
CE35	1	1	1	EA33502590	Cap., Elect., 3.3μF, 25V
CE36	1	1	1	EA33502590	Cap., Elect., 3.3μF, 25V
CE37	1	1	1	DD11040010	Cap., Ceramic, 4pF, 50V
CE38	1	1	1	DD11040010	Cap., Ceramic, 4pF, 50V
CE39	1	1	1	EE47502540	Cap., Elect., 4.7μF, 25V
CE40	1	1	1	EE47502540	Cap., Elect., 4.7μF, 25V
CE41	1	1	1	DD12100010	Cap., Ceramic, 10pF, 50V
CE42	1	1	1	DD12100010	Cap., Ceramic, 10pF, 50V
CE43	1	1	1	EA10701090	Cap., Elect., 100μF, 10V
CE44	1	1	1	EA10701090	Cap., Elect., 100μF, 10V
CE45	1	1	1	DK18403010	Cap., Ceramic, 0.04μF +100%, -0%, 50V
CE46	1	1	1	DK18403010	Cap., Ceramic, 0.04μF +100%, -0%, 50V
JE01	1	1	1	YP06000590	Plug
JE02	1	1	1	YP10001130	Plug

REF. DESIG.	Q'TY			PART NO.	DESCRIPTION
	U	C	E		
JE03	1	1	1	YP10001130	Plug
JE04	1	1	1	YP10001130	Plug
JE05	1	1	1	YP10001130	Plug
JE06	1	1	1	YP10001130	Plug
JE07	1	1	1	YP10001130	Plug
JE08	1	1	1	YP10001130	Plug
JE09	1	1	1	YP10001130	Plug
JE10	1	1	1	YP10001130	Plug
PE01	1	1	1	YK22130210	P.W. Board, Pre & Tone Amp
	1	1	1	ZZ22111210	P.W. Board Assembly
QE01	1	1	1	HT107982A0	Transistor, 2SA798 (x2) F or G
QE02	1	1	1	HT107982A0	Transistor, 2SA798 (x2) F or G
QE03	1	1	1	HT107982A0	Transistor, 2SA798 (x2) F or G
QE04	1	1	1	HT107982A0	Transistor, 2SA798 (x2) F or G
QE05	1	1	1	HT313452A0	Transistor, 2SC1345 D or E
QE06	1	1	1	HT313452A0	Transistor, 2SC1345 D or E
QE07	1	1	1	HT313452A0	Transistor, 2SC1345 D or E
QE08	1	1	1	HT313452A0	Transistor, 2SC1345 D or E
RE01	1	1	1	RM05030710	Res., Variable, 50kΩ (MN)
RE02	1	1	1	RD01040080	Res., Variable, 100kΩ (B)
RE03	1	1	1	RD01040080	Res., Variable, 100kΩ (B)
RE04	1	1	1	RD01040080	Res., Variable, 100kΩ (B)
RE05	1	1	1	RT05105140	Res., Fixed, 1MΩ ±5%, ¼W
RE06	1	1	1	RT05105140	Res., Fixed, 1MΩ ±5%, ¼W
RE07	1	1	1	RT05222140	Res., Fixed, 2.2kΩ ±5%, ¼W
RE08	1	1	1	RT05222140	Res., Fixed, 2.2kΩ ±5%, ¼W
RE09	1	1	1	RT05113140	Res., Fixed, 11kΩ ±5%, ¼W
RE10	1	1	1	RT05113140	Res., Fixed, 11kΩ ±5%, ¼W
RE11	1	1	1	RT05104140	Res., Fixed, 100kΩ ±5%, ¼W
RE12	1	1	1	RT05104140	Res., Fixed, 100kΩ ±5%, ¼W
RE13	1	1	1	RT05273140	Res., Fixed, 27kΩ ±5%, ¼W
RE14	1	1	1	RT05273140	Res., Fixed, 27kΩ ±5%, ¼W
RE15	1	1	1	RT05183140	Res., Fixed, 18kΩ ±5%, ¼W
RE16	1	1	1	RT05183140	Res., Fixed, 18kΩ ±5%, ¼W
RE17	1	1	1	RT05183140	Res., Fixed, 18kΩ ±5%, ¼W
RE18	1	1	1	RT05183140	Res., Fixed, 18kΩ ±5%, ¼W
RE19	1	1	1	RT05514140	Res., Fixed, 510kΩ ±5%, ¼W
RE20	1	1	1	RT05514140	Res., Fixed, 510kΩ ±5%, ¼W
RE21	1	1	1	RT05273140	Res., Fixed, 27kΩ ±5%, ¼W
RE22	1	1	1	RT05273140	Res., Fixed, 27kΩ ±5%, ¼W
RE23	1	1	1	RT05562140	Res., Fixed, 5.6kΩ ±5%, ¼W
RE24	1	1	1	RT05562140	Res., Fixed, 5.6kΩ ±5%, ¼W
RE25	1	1	1	RT05822140	Res., Fixed, 8.2kΩ ±5%, ¼W
RE26	1	1	1	RT05822140	Res., Fixed, 8.2kΩ ±5%, ¼W
RE27	1	1	1	RT05822140	Res., Fixed, 8.2kΩ ±5%, ¼W
RE28	1	1	1	RT05822140	Res., Fixed, 8.2kΩ ±5%, ¼W
RE31	1	1	1	RT05562140	Res., Fixed, 5.6kΩ ±5%, ¼W
RE32	1	1	1	RT05562140	Res., Fixed, 5.6kΩ ±5%, ¼W
RE33	1	1	1	RT05562140	Res., Fixed, 5.6kΩ ±5%, ¼W
RE34	1	1	1	RT05562140	Res., Fixed, 5.6kΩ ±5%, ¼W
RE35	1	1	1	RT05113140	Res., Fixed, 11kΩ ±5%, ¼W
RE36	1	1	1	RT05113140	Res., Fixed, 11kΩ ±5%, ¼W
RE37	1	1	1	RT05113140	Res., Fixed, 11kΩ ±5%, ¼W
RE38	1	1	1	RT05113140	Res., Fixed, 11kΩ ±5%, ¼W
RE39	1	1	1	RT05222140	Res., Fixed, 2.2kΩ ±5%, ¼W
RE40	1	1	1	RT05222140	Res., Fixed, 2.2kΩ ±5%, ¼W

U: For U.S.A.
 C: For Canada
 E: For Europe

REF. DESIG.	Q'TY			PART NO.	DESCRIPTION
	U	C	E		
RE41	1	1	1	RT05124140	Res., Fixed, 120kΩ±5%, ¼W
RE42	1	1	1	RT05124140	Res., Fixed, 120kΩ±5%, ¼W
RE43	1	1	1	RT05123140	Res., Fixed, 12kΩ ±5%, ¼W
RE44	1	1	1	RT05123140	Res., Fixed, 12kΩ ±5%, ¼W
RE45	1	1	1	RT05393140	Res., Fixed, 39kΩ ±5%, ¼W
RE46	1	1	1	RT05393140	Res., Fixed, 39kΩ ±5%, ¼W
RE47	1	1	1	RT05105140	Res., Fixed, 1MΩ ±5%, ¼W
RE48	1	1	1	RT05105140	Res., Fixed, 1MΩ ±5%, ¼W
RE49	1	1	1	RT05682140	Res., Fixed, 6.8kΩ ±5%, ¼W
RE50	1	1	1	RT05682140	Res., Fixed, 6.8kΩ ±5%, ¼W
RE51	1	1	1	RT05330140	Res., Fixed, 33Ω ±5%, ¼W
RE52	1	1	1	RT05330140	Res., Fixed, 33Ω ±5%, ¼W
RE55	1	1	1	RT05471140	Res., Fixed, 470Ω ±5%, ¼W
RE56	1	1	1	RT05471140	Res., Fixed, 470Ω ±5%, ¼W
RE57	1	1	1	RT05472140	Res., Fixed, 4.7kΩ ±5%, ¼W
RE58	1	1	1	RT05472140	Res., Fixed, 4.7kΩ ±5%, ¼W
RE59	1	1	1	RT05913140	Res., Fixed, 91kΩ ±5%, ¼W
RE60	1	1	1	RT05913140	Res., Fixed, 91kΩ ±5%, ¼W
SE01	1	1	1	SR04050140	Rotary Switch
CH01	1	1	1	DF15104050	Cap., Film, 0.1μF, 50V
CH02	1	1	1	DF15104050	Cap., Film, 0.1μF, 50V
CH03	1	1	1	DF15104050	Cap., Film, 0.1μF, 50V
CH04	1	1	1	DF15104050	Cap., Film, 0.1μF, 50V
CH05	1	1	1	DF15104050	Cap., Film, 0.1μF, 50V
CH06	1	1	1	DF15104050	Cap., Film, 0.1μF, 50V
CH07	1	1	1	DF15152050	Cap., Film, 1500pF, 50V
CH08	1	1	1	DF15152050	Cap., Film, 1500pF, 50V
CH09	1	1	1	DD15391010	Cap., Ceramic, 390pF, 50V
CH10	1	1	1	DD15391010	Cap., Ceramic, 390pF, 50V
CH11	1	1	1	EE22505040	Cap., Elect., 2.2μF, 50V
CH12	1	1	1	EE22505040	Cap., Elect., 2.2μF, 50V
CH13	1	1	1	DF15222050	Cap., Film, 2200pF, 50V
CH14	1	1	1	DF15222050	Cap., Film, 2200pF, 50V
CH15	1	1	1	EE10602540	Cap., Elect., 10μF, 25V
CH16	1	1	1	EE10602540	Cap., Elect., 10μF, 25V
JH01	1	1	1	YP10001130	Plug
JH02	1	1	1	YP10001130	Plug
JH03	1	1	1	YP10001130	Plug
JH04	1	1	1	YP10001130	Plug
JH05	1	1	1	YP10001130	Plug
JH06	1	1	1	YP10001130	Plug
JH07	1	1	1	YP10001130	Plug
JH08	1	1	1	YP10001130	Plug
JH09	1	1	1	YP10001130	Plug
JH10	1	1	1	YP10001130	Plug
QH01	1	1	1	HT313452A0	Transistor, 2SC1345 D or E
QH02	1	1	1	HT313452A0	Transistor, 2SC1345 D or E
QH03	1	1	1	HT313452A0	Transistor, 2SC1345 D or E
QH04	1	1	1	HT313452A0	Transistor, 2SC1345 D or E
RH01	1	1	1	RT05334140	Res., Fixed, 330kΩ±5%, ¼W
RH02	1	1	1	RT05334140	Res., Fixed, 330kΩ±5%, ¼W
RH03	1	1	1	RT05244140	Res., Fixed, 240kΩ±5%, ¼W
RH04	1	1	1	RT05244140	Res., Fixed, 240kΩ±5%, ¼W
RH05	1	1	1	RT05102140	Res., Fixed, 1kΩ ±5%, ¼W
RH06	1	1	1	RT05102140	Res., Fixed, 1kΩ ±5%, ¼W
RH07	1	1	1	RT05513140	Res., Fixed, 51kΩ ±5%, ¼W
RH08	1	1	1	RT05513140	Res., Fixed, 51kΩ ±5%, ¼W
RH09	1	1	1	RT05103140	Res., Fixed, 10kΩ ±5%, ¼W
RH10	1	1	1	RT05103140	Res., Fixed, 10kΩ ±5%, ¼W
RH11	1	1	1	RT05124140	Res., Fixed, 120kΩ±5%, ¼W
RH12	1	1	1	RT05124140	Res., Fixed, 120kΩ±5%, ¼W

REF. DESIG.	Q'TY			PART NO.	DESCRIPTION
	U	C	E		
RH13	1	1	1	RT05113140	Res., Fixed, 11kΩ ±5%, ¼W
RH14	1	1	1	RT05113140	Res., Fixed, 11kΩ ±5%, ¼W
RH15	1	1	1	RT05113140	Res., Fixed, 11kΩ ±5%, ¼W
RH16	1	1	1	RT05113140	Res., Fixed, 11kΩ ±5%, ¼W
RH17	1	1	1	RT05113140	Res., Fixed, 11kΩ ±5%, ¼W
RH18	1	1	1	RT05113140	Res., Fixed, 11kΩ ±5%, ¼W
RH19	1	1	1	RT05105140	Res., Fixed, 1MΩ ±5%, ¼W
RH20	1	1	1	RT05105140	Res., Fixed, 1MΩ ±5%, ¼W
RH21	1	1	1	RT05102140	Res., Fixed, 1kΩ ±5%, ¼W
RH22	1	1	1	RT05102140	Res., Fixed, 1kΩ ±5%, ¼W
RH23	1	1	1	RT05103140	Res., Fixed, 10kΩ ±5%, ¼W
RH24	1	1	1	RT05103140	Res., Fixed, 10kΩ ±5%, ¼W
RH25	1	1	1	RT05101140	Res., Fixed, 100Ω ±5%, ¼W
RH26	1	1	1	RT05101140	Res., Fixed, 100Ω ±5%, ¼W
RH27	1	1	1	RT05224140	Res., Fixed, 220kΩ±5%, ¼W
RH28	1	1	1	RT05224140	Res., Fixed, 220kΩ±5%, ¼W
JK01	1	1	1	YP10001130	Plug
JK02	1	1	1	YP10001130	Plug
JK03	1	1	1	YP10001130	Plug
JK04	1	1	1	YP10001130	Plug
JK05	1	1	1	YP10001130	Plug
JK06	1	1	1	YP10001130	Plug
JK07	1	1	1	YP10001130	Plug
JK08	1	1	1	YP10001130	Plug
JK09	1	1	1	YJ07000120	Jack, 10P
PK01	1	1	1	YA22180310	P.W. Board, Dolby Socket
	1	1	1	ZZ22180310	P.W. Board Assembly
SK01	1	1	1	SC01020240	Micro Switch
SK02	1	1	1	SC01020240	Micro Switch
JN01	1	1	1	YP10001130	Plug
JN02	1	1	1	YP10001130	Plug
JN03	1	1	1	YP10001130	Plug
JN04	1	1	1	YP10001130	Plug
JN05	1	1	1	YP10001130	Plug
JN06	1	1	1	YP10001130	Plug
JN07	1	1	1	YP10001130	Plug
JN08	1	1	1	YP10001130	Plug
JN09	1	1	1	YP10001130	Plug
JN10	1	1	1	YP10001130	Plug
JN11	1	1	1	YP10001130	Plug
PN01	1	1	1	YF22130030	P.W. Board, Speaker Switches
	1	1	1	ZZ22130030	P.W. Board Assembly
RN01	1	1	1	GJ05331020	Res., Fixed, 330Ω ±5%, 2W
RN02	1	1	1	GJ05331020	Res., Fixed, 330Ω ±5%, 2W
RN03	1	1	1	GJ05151010	Res., Fixed, 150Ω ±5%, 1W
RN04	1	1	1	GJ05151010	Res., Fixed, 150Ω ±5%, 1W
SN01	1	1	1	SP04020200	Pushswitch
FP01	1	1	1	FS10400800	Fuse, 4AT (SEMKO)
FP02	1	1	1	FS10100800	Fuse, 1AT (SEMKO)
FP03	1	1	1	FS10100800	Fuse, 1AT (SEMKO)
JP01	1	1	1	YJ08000200	Jack
JP02	1	1	1	YJ08000200	Jack
JP03	1	1	1	YJ08000200	Jack
JP04	1	1	1	YJ08000200	Jack
JP05	1	1	1	YJ08000200	Jack
JP06	1	1	1	YJ08000200	Jack

U: For U.S.A.
C: For Canada
E: For Europe

REF. DESIG.	Q'TY			PART NO.	DESCRIPTION
	U	C	E		
JP07			1	YP10001130	Plug
JP08			1	YP10001130	Plug
JP09			1	YP10001130	Plug
JP10			1	YP10001130	Plug
JP11			1	YP10001130	Plug
JP12			1	YP10001130	Plug
PP01			1	YF22130080	P.W. Board, Fuse
			1	ZZ22130080	P.W. Board Assembly
CS01	1	1	1	DK16681010	Cap., Ceramic, 680pF, 50V
CS02	1	1	1	DK16681010	Cap., Ceramic, 680pF, 50V
CS03	1	1	1	DF16104010	Cap., Film, 0.1μF, 50V
CS04	1	1	1	DF16104010	Cap., Film, 0.1μF, 50V
JS01	1	1	1	YP10001130	Plug
JS02	1	1	1	YP10001130	Plug
JS03	1	1	1	YP10001130	Plug
JS04	1	1	1	YP10001130	Plug
JS05	1	1	1	YP10001130	Plug
JS06	1	1	1	YP10001130	Plug
JS07	1	1	1	YP10001130	Plug
JS08	1	1	1	YP10001130	Plug
JS09	1	1	1	YP10001130	Plug
JS10	1	1	1	YP10001130	Plug
JS11	1	1	1	YP10001130	Plug
JS12	1	1	1	YP10001130	Plug
JS13	1	1	1	YP10001130	Plug
JS14	1	1	1	YP10001130	Plug
JS15	1	1	1	YP10001130	Plug
JS16	1	1	1	YP10001130	Plug
JS17	1	1	1	YP10001130	Plug
JS18	1	1	1	YP10001130	Plug
JS19	1	1	1	YP10001130	Plug
JS20	1	1	1	YP10001130	Plug
JS21	1	1	1	YP10001130	Plug
JS22	1	1	1	YP10001130	Plug
JS23	1	1	1	YP10001130	Plug
JS24	1	1	1	YP10001130	Plug
JS25	1	1	1	YP10001130	Plug
JS26	1	1	1	YP10001130	Plug
JS27	1	1	1	YP10001130	Plug
JS28	1	1	1	YP10001130	Plug
JS29	1	1	1	YP10001130	Plug
JS30	1	1	1	YP10001130	Plug
JS31	1	1	1	YP10001130	Plug
JS32	1	1	1	YP10001130	Plug
JS33	1	1	1	YP10001130	Plug
JS34	1	1	1	YP10001130	Plug
JS35	1	1	1	YP10001130	Plug
JS36	1	1	1	YP10001130	Plug
JS37	1	1	1	YP10001130	Plug
JS38	1	1	1	YP10001130	Plug
JS39	1	1	1	YP10001130	Plug
JS40	1	1	1	YP10001130	Plug
JS41	1	1	1	YP10001130	Plug
JS42	1	1	1	YP10001130	Plug
JS43	1	1	1	YP10001130	Plug
JS44	1	1	1	YP10001130	Plug
PS01	1	1	1	YK22110210	P.W. Board, Tape Mon. & Filter Switches
	1	1	1	ZZ22110210	P.W. Board Assembly

REF. DESIG.	Q'TY			PART NO.	DESCRIPTION
	U	C	E		
QS01	1	1	1	HT107202B0	Transistor, 2SA720 Q or R
RS01	1	1	1	RT05102140	Res., Fixed, 1kΩ ±5%, ¼W
RS02	1	1	1	RT05102140	Res., Fixed, 1kΩ ±5%, ¼W
RS03	1	1	1	RT05103140	Res., Fixed, 10kΩ ±5%, ¼W
RS04	1	1	1	RT05203140	Res., Fixed, 20kΩ ±5%, ¼W
RS05	1	1	1	RT05203140	Res., Fixed, 20kΩ ±5%, ¼W
RS06	1	1	1	RT05392140	Res., Fixed, 3.9kΩ ±5%, ¼W
RS07	1	1	1	RT05392140	Res., Fixed, 3.9kΩ ±5%, ¼W
RS08	1	1	1	GF05100140	Res., Fixed, 10Ω ±5%, ¼W
SS01	1	1	1	SP04090010	Pushswitch
JY01	1	1	1	YP10001130	Plug
JY02	1	1	1	YP10001130	Plug
JY03	1	1	1	YP10001130	Plug
JY04	1	1	1	YP10001130	Plug
JY05	1	1	1	YP10001130	Plug
JY07	1	1	1	YP10001130	Plug
JY08	1	1	1	YP10001130	Plug
PY01	1	1	1	YF22130040	P.W. Board, Function Lamp
	1	1	1	ZZ22111040	P.W. Board Assembly
QY01	1	1	1	H110004030	L.E.D., SPL-132P
QY02	1	1	1	H110004030	L.E.D., SPL-132P
QY03	1	1	1	H110004030	L.E.D., SPL-132P
QY04	1	1	1	H110004030	L.E.D., SPL-132P
QY05	1	1	1	H110004030	L.E.D., SPL-132P
RY01	1	1	1	RT05102140	Res., Fixed, 1kΩ ±5%, ¼W
RY02	1	1	1	RT05102140	Res., Fixed, 1kΩ ±5%, ¼W
JZ01	1	1	1	YP10001130	Plug
JZ02	1	1	1	YP10001130	Plug
JZ03	1	1	1	YP10001130	Plug
JZ04	1	1	1	YP10001130	Plug
JZ05	1	1	1	YP10001130	Plug
JZ06	1	1	1	YP10001130	Plug
JZ07	1	1	1	YP10001130	Plug
JZ08	1	1	1	YJ08000170	Jack
JZ09	1	1	1	YJ08000170	Jack
JZ10	1	1	1	YJ08000170	Jack
JZ11	1	1	1	YJ08000170	Jack
JZ12	1	1	1	YJ08000170	Jack
JZ13	1	1	1	YJ08000170	Jack
JZ14	1	1	1	YJ08000170	Jack
JZ15	1	1	1	YJ08000170	Jack
JZ16	1	1	1	YJ08000170	Jack
JZ17	1	1	1	YJ08000170	Jack
PZ01	1	1	1	YF22130050	P.W. Board, Dial Lamp
	1	1	1	ZZ22130050	P.W. Board Assembly
VZ01	1	1	1	IN10080070	Lamp, 8V 200mA
VZ02	1	1	1	IN10080070	Lamp, 8V 200mA
VZ03	1	1	1	IN10080070	Lamp, 8V 200mA
VZ04	1	1	1	IN10080070	Lamp, 8V 200mA
VZ05	1	1	1	IN10080070	Lamp, 8V 200mA
C001	1	1	1	DK17103010	Cap., Ceramic, 0.01μF, 50V
C002	1	1	1	DK17103010	Cap., Ceramic, 0.01μF, 50V
C003	1	1	1	EC10905520	Cap., Elect., 1000μF, 55V
C004	1	1	1	EC10905520	Cap., Elect., 1000μF, 55V
C005	1	1	1	DF17104520	Cap., Film, 0.1μF, 200V
C006	1	1	1	DF17104520	Cap., Film, 0.1μF, 200V
C009			1	DO07223510	Cap., Oil-Paper, 0.022μF

U: For U.S.A.
 C: For Canada
 E: For Europe

REF. DESIG.	Q'TY			PART NO.	DESCRIPTION
	U	C	E		
C010			1	DO07223510	Cap., Oil-Paper, 0.022 μ F
F001			1	FS10400800	Fuse, 4A, 25mm
F001	1	1		FS10500040	Fuse, 5A(UL)
G001	1			BF10400030	Cap. Comp., Spark Killer
G001		1		BF33300020	Cap. Comp., Spark Killer
J001	1	1	1	YT01010050	Terminal, Ground (GND)
J002	1	1	1	YT02040190	Terminal, Phono 1/Phono 2
J003	1	1		YT02020140	Terminal, Aux
J003			1	YT02040140	Terminal, Aux 1/Aux 2
J004	1	1	1	YT02040140	Terminal, Tape Mon. 1
J005	1	1	1	YT02040140	Terminal, Tape Mon. 2
J006	1	1	1	YT02040170	Terminal, Pre Out/Main In
J007	1	1	1	YT02010130	Terminal, Quad Out
J008	1	1		YJ04000560	Jack, Switched
J009	1	1		YJ04000560	Jack, Unswitched
J010	1	1	1	YT03040160	Terminal, System 1
J011	1	1	1	YT03040160	Terminal, System 2
J012	1	1	1	YJ01001070	Jack, Dubbing In
J013	1	1	1	YJ01001080	Jack, Dubbing Out
J014	1	1	1	YJ01001060	Jack, Phones
J015	1	1	1	YJ08000250	Jack, Meter Lamp Socket
J016	1	1	1	YJ08000250	Jack, Meter Lamp Socket
J017	1	1	1	YJ05000200	Jack
J018	1	1	1	YJ05000200	Jack
J019	1	1	1	YJ05000200	Jack
J020	1	1	1	YJ05000200	Jack
J021	1	1	1	YJ06001040	Jack
J022	1	1	1	YJ06001040	Jack
J023	1	1	1	YJ06001050	Jack
J024	1	1	1	YJ06001050	Jack
J030	1			YJ08000120	Jack, Fuse Holder
J030			1	YJ08000220	Jack, Fuse Holder
J030	1			YJ08000230	Jack, Fuse Holder
J032	1		1	BY03110010	Plug, Voltage Selector
J033	1		1	YL09030010	Terminal
L001	1	1	1	LF11200520	Antenna Coil
L002	1	1	1	LC13320020	Choke Coil, 3.3 μ H
L003	1		1	TS61401014	Power Transformer
L003	1	1		TS61402012	Power Transformer
M001	1	1	1	IM11055080	D.C. Meter, Signal Strength
M002	1	1	1	IM11055050	D.C. Meter, Center Tuning
Q001	1	1	1	HT206452A0	Transistor, 2SB645 R or S
Q002	1	1	1	HT406652A0	Transistor, 2SD665 R or S
Q003	1	1	1	HT206452A0	Transistor, 2SB645 R or S
Q004	1	1	1	HT406652A0	Transistor, 2SD665 R or S
Q005	1	1	1	HV00007120	Varistor, MV-103Y
Q006	1	1	1	HV00007120	Varistor, MV-103Y
Q007	1	1	1	HD20004290	Diode, S5VB-20
R001	1	1		RC10225120	Res., Fixed, 2.2M Ω \pm 10%, 1/2W
R002	1	1	1	RM05030740	Res., Variable, 50k Ω (B)
S001	1	1		SP01010210	Pushswitch
S001			1	SP02010300	Pushswitch
V001	1	1	1	IN10080430	Lamp, Meter
V002	1	1	1	IN10080430	Lamp, Meter
V004	1	1		IN10080340	Lamp, DLB-1
V005	1	1	1	IN10080340	Lamp, Stereo
W001			1	YC01900030	A.C. Power Cord
W001	1	1		YC02400220	A.C. Power Cord
C101	1	1	1	CA43700020	Cap., Variable, FM-4/AM-3
C102	1	1	1	DD16120020	Cap., Ceramic, 12pF

REF. DESIG.	Q'TY			PART NO.	DESCRIPTION
	U	C	E		
C103	1	1	1	DD16101010	Cap., Ceramic, 100pF
C104	1	1	1	DD15200010	Cap., Ceramic, 20pF
C105	1	1	1	DK18203030	Cap., Ceramic, 0.02 μ F
C106	1	1	1	DK18203030	Cap., Ceramic, 0.02 μ F
C107	1	1	1	DD16120020	Cap., Ceramic, 12pF
C108	1	1	1	DD16120020	Cap., Ceramic, 12pF
C109	1	1	1	DD10010020	Cap., Ceramic, 1pF
C110	1	1	1	DD16150040	Cap., Ceramic, 15pF
C111	1	1	1	DD16082010	Cap., Ceramic, 8.2pF
C112	1	1	1	DD16470020	Cap., Ceramic, 47pF
C113	1	1	1	DD16150030	Cap., Ceramic, 15pF
C114	1	1	1	DK18203030	Cap., Ceramic, 0.02 μ F
C115	1	1	1	DK18203030	Cap., Ceramic, 0.02 μ F
C116	1	1	1	DK18203030	Cap., Ceramic, 0.02 μ F
C151	1	1	1	DK17103010	Cap., Ceramic, 0.01 μ F
C152	1	1	1	EA10701690	Cap., Elect., 100 μ F, 16V
C153	1	1	1	DK17102010	Cap., Ceramic, 0.001 μ F
C154	1	1	1	DF16403010	Cap., Film, 0.04 μ F
C155	1	1	1	DK17103010	Cap., Ceramic, 0.01 μ F
C156	1	1	1	DF17223010	Cap., Film, 0.022 μ F
C157	1	1	1	DD16150070	Cap., Ceramic, 15pF
C158	1	1	1	DF65391010	Cap., Film, 390pF
C159	1	1	1	DK18403020	Cap., Ceramic, 0.04 μ F
C160	1	1	1	DD16600010	Cap., Ceramic, 60pF
C161	1	1	1	DK17103010	Cap., Ceramic, 0.01 μ F
C162	1	1	1	DK18403020	Cap., Ceramic, 0.04 μ F
C163	1	1	1	EA33502590	Cap., Elect., 3.3 μ F, 25V
C164	1	1	1	EA33502590	Cap., Elect., 3.3 μ F, 25V
C165	1	1	1	DK17102010	Cap., Ceramic, 0.001 μ F
C166	1	1	1	DK17103010	Cap., Ceramic, 0.01 μ F
C167	1	1	1	DK17502010	Cap., Ceramic, 0.005 μ F
C168	1	1	1	DF16104010	Cap., Film, 0.1 μ F
C169	1	1	1	EA10701690	Cap., Elect., 100 μ F, 16V
C170	1	1	1	EA10505090	Cap., Elect., 1 μ F, 50V
C171	1	1	1	DK17103010	Cap., Ceramic, 0.01 μ F
F151	1	1	1	FF10045160	Ceramic Filter, AM
J101	1	1	1	YJ06001150	Jack
J102	1	1	1	YJ06001150	Jack
J151	1	1	1	YP10001130	Plug
J152	1	1	1	YP10001130	Plug
J153	1	1	1	YP10001130	Plug
J154	1	1	1	YP10001130	Plug
J155	1	1	1	YP10001130	Plug
J156	1	1	1	YP10001130	Plug
J157	1	1	1	YP10001130	Plug
J158	1	1	1	YP10001130	Plug
J159	1	1	1	YP10001130	Plug
J160	1	1	1	YP10001130	Plug
L106	1	1	1	LI70039010	I.F.T., TM122
L107	1	1	1	LC13920010	Choke Coil, WU111
L151	1	1	1	LC13320020	Choke Coil, 3.3 μ H
L152	1	1	1	LA10010190	Antenna Coil, AM RF
L153	1	1	1	LO10010480	OSC Coil, AM
L154	1	1	1	LC13320020	Choke Coil, 3.3 μ H
L155	1	1	1	LI10015010	I.F.T., AM
L156	1	1	1	LI10015060	I.F.T., AM
P100	1	1	1	YD29920010	P.W. Board, FM/AM Front End
	1	1	1	AV01202070	FM/AM Front End

U: For U.S.A.
C: For Canada
E: For Europe

REF. DESIG.	Q'TY			PART NO.	DESCRIPTION
	U	C	E		
Q101	1	1	1	HF400451B0	F.E.T., 3SK45 B
Q102	1	1	1	HF400591A0	F.E.T., 3SK59 Y
Q103	1	1	1	HT307101C0	Transistor, 2SC710 C
Q151	1	1	1	HC10019010	I.C., HA1197
Q152	1	1	1	HT313272A0	Transistor, 2SC1327 S or T
Q153	1	1	1	HV00006120	Varistor, MV-203
R101	1	1	1	GD05104140	Res., Fixed, 100kΩ ±5%, ¼W
R102	1	1	1	GD05470140	Res., Fixed, 47Ω ±5%, ¼W
R103	1	1	1	GD05104140	Res., Fixed, 100kΩ ±5%, ¼W
R104	1	1	1	GD05105140	Res., Fixed, 1MΩ ±5%, ¼W
R105	1	1	1	GD05681140	Res., Fixed, 680Ω ±5%, ¼W
R106	1	1	1	GD05153140	Res., Fixed, 15kΩ ±5%, ¼W
R107	1	1	1	GD05472140	Res., Fixed, 4.7kΩ ±5%, ¼W
R108	1	1	1	GD05103140	Res., Fixed, 10kΩ ±5%, ¼W
R109	1	1	1	GD05821140	Res., Fixed, 820Ω ±5%, ¼W
R110	1	1	1	GD05101140	Res., Fixed, 100Ω ±5%, ¼W
R111	1	1	1	GD05101140	Res., Fixed, 100Ω ±5%, ¼W
R112	1	1	1	GD05330140	Res., Fixed, 33Ω ±5%, ¼W
R151	1	1	1	RT05561140	Res., Fixed, 560Ω ±5%, ¼W
R152	1	1	1	RT05331140	Res., Fixed, 330Ω ±5%, ¼W
R153	1	1	1	RT05272140	Res., Fixed, 2.7kΩ ±5%, ¼W
R154	1	1	1	RT05473140	Res., Fixed, 47kΩ ±5%, ¼W
R155	1	1	1	RT05104140	Res., Fixed, 100kΩ ±5%, ¼W
R156	1	1	1	RT05302140	Res., Fixed, 3kΩ ±5%, ¼W
R157	1	1	1	RA01020210	Res., Semifixed, 1kΩ
R158	1	1	1	RT05103140	Res., Fixed, 10kΩ ±5%, ¼W
R159	1	1	1	RT05103140	Res., Fixed, 10kΩ ±5%, ¼W
R160	1	1	1	RT05301140	Res., Fixed, 300Ω ±5%, ¼W
R161	1	1	1	RT05102140	Res., Fixed, 1kΩ ±5%, ¼W
R162	1	1	1	RT05124140	Res., Fixed, 120kΩ ±5%, ¼W
R163	1	1	1	RT05303140	Res., Fixed, 30kΩ ±5%, ¼W
R164	1	1	1	RT05751140	Res., Fixed, 750Ω ±5%, ¼W
R165	1	1	1	RT05332140	Res., Fixed, 3.3kΩ ±5%, ¼W
R166	1	1	1	RT05104140	Res., Fixed, 100kΩ ±5%, ¼W
R167	1	1	1	RT05101140	Res., Fixed, 100Ω ±5%, ¼W
R168	1	1	1	RT05101140	Res., Fixed, 100Ω ±5%, ¼W
C201	1	1	1	DK17103010	Cap., Ceramic, 0.01μF
C202	1	1	1	DK18403020	Cap., Ceramic, 0.04μF
C203	1	1	1	DK18403020	Cap., Ceramic, 0.04μF
C204	1	1	1	DK18203030	Cap., Ceramic, 0.02μF
C205	1	1	1	DK18403020	Cap., Ceramic, 0.04μF
C206	1	1	1	DK17103010	Cap., Ceramic, 0.01μF
C207	1	1	1	DK17103010	Cap., Ceramic, 0.01μF
C208	1	1	1	DD15400040	Cap., Ceramic, 40pF
C209	1	1	1	DK18203030	Cap., Ceramic, 0.02μF
C210	1	1	1	DK18403020	Cap., Ceramic, 0.04μF
C211	1	1	1	DK18403020	Cap., Ceramic, 0.04μF
C213	1	1	1	DK18403020	Cap., Ceramic, 0.04μF
C214	1	1	1	DK18403020	Cap., Ceramic, 0.04μF
C215	1	1	1	DK18403020	Cap., Ceramic, 0.04μF
C216	1	1	1	DK18403020	Cap., Ceramic, 0.04μF
C217	1	1	1	DK18203030	Cap., Ceramic, 0.02μF
C218	1	1	1	EA47503590	Cap., Elect., 4.7μF, 35V
C219	1	1	1	EA10701690	Cap., Elect., 100μF, 16V
C220	1	1	1	DK18403020	Cap., Ceramic, 0.04μF
C221	1	1	1	EA47405010	Cap., Elect., 0.47μF, 50V
C222	1	1	1	DD15500050	Cap., Ceramic, 50pF
C223	1	1	1	DK18203030	Cap., Ceramic, 0.02μF
C224	1	1	1	EA10505090	Cap., Elect., 1μF, 50V
C225	1	1	1	DK18403020	Cap., Ceramic, 0.04μF, 25V
C226	1	1	1	DK18403020	Cap., Ceramic, 0.04μF

REF. DESIG.	Q'TY			PART NO.	DESCRIPTION
	U	C	E		
C227	1	1	1	EA10601690	Cap., Elect., 10μF, 16V
C228	1	1	1	EA10505090	Cap., Elect., 1μF, 50V
C229	1	1	1	EA10601690	Cap., Elect., 10μF, 16V
C230	1	1	1	CT15000010	Cap., Trimmer
C231	1	1	1	CT15000010	Cap., Trimmer
F201	1	1	1	FF11070050	Ceramic Filter
F202	1	1	1	FF11070050	Ceramic Filter
F203	1	1	1	FF11070050	Ceramic Filter
F204	1	1	1	FF11070050	Ceramic Filter
J201	1	1	1	YP10001130	Plug
J202	1	1	1	YP10001130	Plug
J203	1	1	1	YP10001130	Plug
J204	1	1	1	YP10001130	Plug
J205	1	1	1	YP10001130	Plug
J206	1	1	1	YP10001130	Plug
J207	1	1	1	YP10001130	Plug
J208	1	1	1	YP10001130	Plug
J209	1	1	1	YP10001130	Plug
J210	1	1	1	YP10001130	Plug
J211	1	1	1	YP10001130	Plug
J212	1	1	1	YP10001130	Plug
J213	1	1	1	YP10001130	Plug
L201	1	1	1	LC13320020	Choke Coil, 3.3μH
L202	1	1	1	LC11830010	Choke Coil, 18μH
L203	1	1	1	LI14019020	I.F.T., FM
P200	1	1	1	YG22130010	P.W. Board, AM Tuner, FM IF & MPX
	1	1	1	ZZ22130010	P.W. Board Assembly
				ZZ22138010	P.W. Board Assembly
Q201	1	1	1	HT308291C0	Transistor, 2SC829C
Q202	1	1	1	HD10003020	Diode, 20A90M
Q203	1	1	1	HD10003020	Diode, 20A90M
Q204	1	1	1	HC10011060	I.C., UPC555H
Q205	1	1	1	HD10003020	Diode, 20A90M
Q206	1	1	1	HD10003020	Diode, 20A90M
Q207	1	1	1	HC10021010	I.C., HA1137W
Q208	1	1	1	HD20001210	Diode, 1S2473 Yel
Q209	1	1	1	HD20001210	Diode, 1S2473 Yel
Q210	1	1	1	HT309452A0	Transistor, 2SC945 Q or R
Q211	1	1	1	HD20001210	Diode, 1S2473 Yel
Q212	1	1	1	HT309452A0	Transistor, 2SC945 Q or R
Q213	1	1	1	HT313272A0	Transistor, 2SC1327 S or T
Q214	2	2	2	HD20001210	Diode, 1S2473 Yel
R201	1	1	1	RT05471140	Res., Fixed, 470Ω ±5%, ¼W
R202	1	1	1	RT05822140	Res., Fixed, 8.2kΩ ±5%, ¼W
R203	1	1	1	RT05272140	Res., Fixed, 2.7kΩ ±5%, ¼W
R204	1	1	1	RT05104140	Res., Fixed, 100kΩ ±5%, ¼W
R205	1	1	1	RT05471140	Res., Fixed, 470Ω ±5%, ¼W
R206	1	1	1	RT05202140	Res., Fixed, 2kΩ ±5%, ¼W
R207	1	1	1	RT05561140	Res., Fixed, 560Ω ±5%, ¼W
R208	1	1	1	RT05331140	Res., Fixed, 330Ω ±5%, ¼W
R209	1	1	1	RT05331140	Res., Fixed, 330Ω ±5%, ¼W
R210	1	1	1	RT05470140	Res., Fixed, 47Ω ±5%, ¼W
R211	1	1	1	RT05331140	Res., Fixed, 330Ω ±5%, ¼W
R212	1	1	1	RT05102140	Res., Fixed, 1kΩ ±5%, ¼W
R213	1	1	1	RT05470140	Res., Fixed, 47Ω ±5%, ¼W
R214	1	1	1	RT05104140	Res., Fixed, 100kΩ ±5%, ¼W
R215	1	1	1	RT05331140	Res., Fixed, 330Ω ±5%, ¼W
R216	1	1	1	RT05153140	Res., Fixed, 15kΩ ±5%, ¼W

U: For U.S.A.
C: For Canada
E: For Europe

REF. DESIG.	Q'TY			PART NO.	DESCRIPTION
	U	C	E		
R217	1	1	1	RT05123140	Res., Fixed, 12kΩ ±5%, ¼W
R218	1	1	1	RT05222140	Res., Fixed, 2.2kΩ ±5%, ¼W
R219	1	1	1	RT05103140	Res., Fixed, 10kΩ ±5%, ¼W
R220	1	1	1	RT05101140	Res., Fixed, 100Ω ±5%, ¼W
R221	1	1	1	RT05102140	Res., Fixed, 1kΩ ±5%, ¼W
R222	1	1	1	RT05123140	Res., Fixed, 12kΩ ±5%, ¼W
R225	1	1	1	RT05472140	Res., Fixed, 4.7kΩ ±5%, ¼W
R226	1	1	1	RT05103140	Res., Fixed, 10kΩ ±5%, ¼W
R227	1	1	1	RA01030250	Res., Trimmer, 10kΩ
R228	1	1	1	RT05222140	Res., Fixed, 2.2kΩ ±5%, ¼W
R229	1	1	1	RT05222140	Res., Fixed, 2.2kΩ ±5%, ¼W
R230	1	1	1	RT05104140	Res., Fixed, 100kΩ ±5%, ¼W
R231	1	1	1	RT05105140	Res., Fixed, 1MΩ ±5%, ¼W
R232	1	1	1	RT05222140	Res., Fixed, 2.2kΩ ±5%, ¼W
R234	1	1	1	RT05103140	Res., Fixed, 10kΩ ±5%, ¼W
R235	1	1	1	RT05104140	Res., Fixed, 100kΩ ±5%, ¼W
R236	1	1	1	RT05184140	Res., Fixed, 180kΩ ±5%, ¼W
R237	1	1	1	RT05222140	Res., Fixed, 2.2kΩ ±5%, ¼W
R238	1	1	1	RT05473140	Res., Fixed, 47kΩ ±5%, ¼W
R239	1	1	1	RT05222140	Res., Fixed, 2.2kΩ ±5%, ¼W
R240	1	1	1	RT05391140	Res., Fixed, 390Ω ±5%, ¼W
R241	1	1	1	RT05270140	Res., Fixed, 27Ω ±5%, ¼W
R242	1	1	1	RT05270140	Res., Fixed, 27Ω ±5%, ¼W
R243	1	1	1	RT05270140	Res., Fixed, 27Ω ±5%, ¼W
R244	1	1	1	RT05270140	Res., Fixed, 27Ω ±5%, ¼W
C305	1	1	1	EQ47501610	Cap., Elect., 4.7μF, 16V
C306	1	1	1	EA10701690	Cap., Elect., 100μF, 16V
C307	1	1	1	DF17473010	Cap., Film, 0.047μF
C308	1	1	1	EA33502590	Cap., Elect., 3.3μF, 25V
C309	1	1	1	EA22505090	Cap., Elect., 2.2μF, 50V
C310	1	1	1	EQ22405010	Cap., Elect., 0.22μF, 50V
C311	1	1	1	DF65361500	Cap., Film, 360μF, 50V
C312	1	1	1	DD16201010	Cap., Ceramic, 200pF
C313	1	1	1	DD16201010	Cap., Ceramic, 200pF
C314	1	1	1	EA10601690	Cap., Elect., 10μF, 16V
C315	1	1	1	EA10601690	Cap., Elect., 10μF, 16V
C316	1	1	1	DF15153010	Cap., Film, 0.015μF
C317	1	1	1	DF15182050	Cap., Film, 1800pF, 50V
C317	1	1	1	DF15472050	Cap., Film, 4700pF
C318	1	1	1	DF15182050	Cap., Film, 1800pF, 50V
C318	1	1	1	DF15472050	Cap., Film, 4700pF
C319	1	1	1	EA10601690	Cap., Elect., 10μF, 16V
C320	1	1	1	EA10601690	Cap., Elect., 10μF, 16V
C321	1	1	1	EE47502540	Cap., Elect., 4.7μF, 25V
C322	1	1	1	EE47502540	Cap., Elect., 4.7μF, 25V
C323	1	1	1	EE22505040	Cap., Elect., 2.2μF, 50V
C324	1	1	1	EE22505040	Cap., Elect., 2.2μF, 50V
C325	1	1	1	EA47603590	Cap., Elect., 47μF, 35V
C329	1	1	1	DD16200010	Cap., Ceramic, 20pF
C330	1	1	1	DD16200010	Cap., Ceramic, 20pF
C331	1	1	1	DD12100010	Cap., Ceramic, 10pF
C332	1	1	1	DF16683010	Cap., Film, 0.068μF
C333	1	1	1	DF16403010	Cap., Film, 0.04μF
C334	1	1	1	DK18104020	Cap., Ceramic, 0.1μF
C335	1	1	1	EA10505090	Cap., Elect., 1μF, 50V
C336	1	1	1	EA10601690	Cap., Elect., 10μF, 16V
C337	1	1	1	EA47503590	Cap., Elect., 4.7μF, 35V
F301	1	1	1	LS35035010	M.P.X. Coil
J301	1	1	1	YP10001130	Plug
J302	1	1	1	YP10001130	Plug
J303	1	1	1	YP10001130	Plug

REF. DESIG.	Q'TY			PART NO.	DESCRIPTION
	U	C	E		
J304	1	1	1	YP10001130	Plug
J305	1	1	1	YP10001130	Plug
J306	1	1	1	YP10001130	Plug
J307	1	1	1	YP10001130	Plug
J308	1	1	1	YP10001130	Plug
J309	1	1	1	YP10001130	Plug
J310	1	1	1	YP10001130	Plug
J311	1	1	1	YP10001130	Plug
J312	1	1	1	YP10001130	Plug
J313	1	1	1	YP10001130	Plug
J314	1	1	1	YP10001130	Plug
J315	1	1	1	YP10001130	Plug
J316	1	1	1	YP10001130	Plug
J318	1	1	1	YP10001130	Plug
L301	1	1	1	LC21050010	Choke Coil, 1mH
Q301	1	1	1	HC10020010	I.C., HA1196
Q302	1	1	1	HT309452A0	Transistor, 2SC945 Q or R
Q303	1	1	1	HT313272A0	Transistor, 2SC1327 S or T
Q304	1	1	1	HT313272A0	Transistor, 2SC1327 S or T
Q305	1	1	1	HT107212A0	Transistor, 2SA721
Q306	1	1	1	HT107212A0	Transistor, 2SA721
Q307	1	1	1	HT317402B0	Transistor, 2SC1740 R or S
Q308	1	1	1	HT317402B0	Transistor, 2SC1740 R or S
Q309	1	1	1	HT317402B0	Transistor, 2SC1740 R or S
Q310	1	1	1	HD10001050	Diode, 1N60
Q311	1	1	1	HD10001050	Diode, 1N60
R301	1	1	1	RT05101140	Res., Fixed, 100Ω ±5%, ¼W
R302	1	1	1	RT05104140	Res., Fixed, 100kΩ ±5%, ¼W
R303	1	1	1	RT05104140	Res., Fixed, 100kΩ ±5%, ¼W
R304	1	1	1	RT05104140	Res., Fixed, 100kΩ ±5%, ¼W
R305	1	1	1	RT05102140	Res., Fixed, 1kΩ ±5%, ¼W
R306	1	1	1	RT05223140	Res., Fixed, 22kΩ ±5%, ¼W
R307	1	1	1	RA01030310	Res., Semifixed, 10kΩ(B)
R308	1	1	1	RT05271140	Res., Fixed, 270Ω ±5%, ¼W
R309	1	1	1	RT05104140	Res., Fixed, 100kΩ ±5%, ¼W
R310	1	1	1	RT05103140	Res., Fixed, 10kΩ ±5%, ¼W
R311	1	1	1	RT05153140	Res., Fixed, 15kΩ ±5%, ¼W
R312	1	1	1	RT05153140	Res., Fixed, 15kΩ ±5%, ¼W
R313	1	1	1	RT05103140	Res., Fixed, 10kΩ ±5%, ¼W
R314	1	1	1	RT05222140	Res., Fixed, 2.2kΩ ±5%, ¼W
R315	1	1	1	RT05332140	Res., Fixed, 3.3kΩ ±5%, ¼W
R316	1	1	1	RA02540010	Res., Semifixed, 250kΩ
R317	1	1	1	RT05332140	Res., Fixed, 3.3kΩ ±5%, ¼W
R318	1	1	1	RT05223140	Res., Fixed, 22kΩ ±5%, ¼W
R319	1	1	1	RT05224140	Res., Fixed, 220kΩ ±5%, ¼W
R320	1	1	1	RT05332140	Res., Fixed, 3.3kΩ ±5%, ¼W
R321	1	1	1	RT05332140	Res., Fixed, 3.3kΩ ±5%, ¼W
R322	1	1	1	RT05153140	Res., Fixed, 15kΩ ±5%, ¼W
R322	1	1	1	RT05163140	Res., Fixed, 16kΩ ±5%, ¼W
R323	1	1	1	RT05153140	Res., Fixed, 15kΩ ±5%, ¼W
R323	1	1	1	RT05163140	Res., Fixed, 16kΩ ±5%, ¼W
R324	1	1	1	RT05105140	Res., Fixed, 1MΩ ±5%, ¼W
R325	1	1	1	RT05333140	Res., Fixed, 33kΩ ±5%, ¼W
R326	1	1	1	RT05333140	Res., Fixed, 33kΩ ±5%, ¼W
R327	1	1	1	RT05105140	Res., Fixed, 1MΩ ±5%, ¼W
R328	1	1	1	RT05103140	Res., Fixed, 10kΩ ±5%, ¼W
R329	1	1	1	RT05101140	Res., Fixed, 100Ω ±5%, ¼W
R330	1	1	1	RT05101140	Res., Fixed, 100Ω ±5%, ¼W
R331	1	1	1	RT05103140	Res., Fixed, 10kΩ ±5%, ¼W
R332	1	1	1	RA05010050	Res., Semifixed, 500Ω(B)
R333	1	1	1	RA05010050	Res., Semifixed, 500Ω(B)

U: For U.S.A.
C: For Canada
E: For Europe

REF. DESIG.	Q'TY			PART NO.	DESCRIPTION
	U	C	E		
R334	1	1		RT05222140	Res., Fixed, 2.2kΩ ±5%, ¼W
R334			1	RT05332140	Res., Fixed, 3.3kΩ ±5%, ¼W
R335	1	1		RT05122140	Res., Fixed, 1.2kΩ ±5%, ¼W
R336	1	1		RT05222140	Res., Fixed, 2.2kΩ ±5%, ¼W
R336			1	RT05332140	Res., Fixed, 3.3kΩ ±5%, ¼W
R337	1	1		RT05122140	Res., Fixed, 1.2kΩ ±5%, ¼W
R338	1	1	1	RT05101140	Res., Fixed, 100Ω ±5%, ¼W
R339	1	1		RT05101140	Res., Fixed, 100Ω ±5%, ¼W
R340	1	1	1	RT05101140	Res., Fixed, 100Ω ±5%, ¼W
R341	1	1		RT05101140	Res., Fixed, 100Ω ±5%, ¼W
R342	1	1	1	RT05473140	Res., Fixed, 47kΩ ±5%, ¼W
R343	1	1		RT05473140	Res., Fixed, 47kΩ ±5%, ¼W
R344	1	1	1	RT05473140	Res., Fixed, 47kΩ ±5%, ¼W
R345	1	1	1	RT05473140	Res., Fixed, 47kΩ ±5%, ¼W
R346	1	1	1	RT05470140	Res., Fixed, 47Ω ±5%, ¼W
R347	1	1	1	RT05102140	Res., Fixed, 1kΩ ±5%, ¼W
R348	1	1	1	RT05562140	Res., Fixed, 5.6kΩ ±5%, ¼W
R349	1	1	1	RT05104140	Res., Fixed, 100kΩ ±5%, ¼W
R350	1	1	1	RT05562140	Res., Fixed, 5.6kΩ ±5%, ¼W
R351	1	1	1	RT05104140	Res., Fixed, 100kΩ ±5%, ¼W
R352	1	1	1	RT05273140	Res., Fixed, 27kΩ ±5%, ¼W
R353	1	1	1	RT05101140	Res., Fixed, 100Ω ±5%, ¼W
R354	1	1	1	RT05102140	Res., Fixed, 1kΩ ±5%, ¼W
R355	1	1	1	RT05273140	Res., Fixed, 27kΩ ±5%, ¼W
R356	1	1	1	RT05104140	Res., Fixed, 100kΩ ±5%, ¼W
R357	1	1	1	RT05564140	Res., Fixed, 560kΩ ±5%, ¼W
R358	1	1	1	RT05124140	Res., Fixed, 120kΩ ±5%, ¼W
R359	1	1	1	RT05153140	Res., Fixed, 15kΩ ±5%, ¼W
R360	1	1	1	RT05562140	Res., Fixed, 5.6kΩ ±5%, ¼W
R361	1	1	1	RT05393140	Res., Fixed, 39kΩ ±5%, ¼W
R362	1	1	1	RT05101140	Res., Fixed, 100Ω ±5%, ¼W
R363	1	1	1	RT05104140	Res., Fixed, 100kΩ ±5%, ¼W
R364	1	1	1	RT05101140	Res., Fixed, 100Ω ±5%, ¼W
R365	1	1	1	RT05103140	Res., Fixed, 10kΩ ±5%, ¼W
C401	1	1	1	EE47502510	Cap., Elect., 4.7μF, 25V
C402	1	1	1	EE47502510	Cap., Elect., 4.7μF, 25V
C403	1	1	1	DD15390010	Cap., Ceramic, 39pF, 50V
C404	1	1	1	DD15390010	Cap., Ceramic, 39pF, 50V
C405	1	1	1	DD15331010	Cap., Ceramic, 330pF, 50V
C406	1	1	1	DD15331010	Cap., Ceramic, 330pF, 50V
C407	1	1	1	DD15331010	Cap., Ceramic, 330pF, 50V
C408	1	1	1	DD15331010	Cap., Ceramic, 330pF, 50V
C409	1	1	1	EV10700360	Cap., Elect., 100μF, 3.15V
C410	1	1	1	EV10700360	Cap., Elect., 100μF, 3.15V
C411	1	1	1	DF14362020	Cap., Film, 3600pF, 50V
C412	1	1	1	DF14362020	Cap., Film, 3600pF, 50V
C413	1	1	1	DF14122010	Cap., Film, 1200pF, 50V
C414	1	1	1	DF14122010	Cap., Film, 1200pF, 50V
C415	1	1	1	DD11040010	Cap., Ceramic, 4pF, 50V
C416	1	1	1	DD11040010	Cap., Ceramic, 4pF, 50V
C417	1	1	1	EV47502560	Cap., Elect., 4.7μF, 25V
C418	1	1	1	EV47502560	Cap., Elect., 4.7μF, 25V
C419	1	1	1	DF16562010	Cap., Film, 5600pF, 50V
C420	1	1	1	DF16562010	Cap., Film, 5600pF, 50V
C423	1	1	1	EA47605090	Cap., Elect., 47μF +100%, -10%, 50V
C424	1	1	1	EA47605090	Cap., Elect., 47μF +100%, -10%, 50V
C425	1	1		DF55362090	Cap., Film, 3600pF, 50V
C426	1	1		DF55362090	Cap., Film, 3600pF, 50V
J401	1	1	1	YP10001130	Plug

REF. DESIG.	Q'TY			PART NO.	DESCRIPTION
	U	C	E		
J402	1	1	1	YP10001130	Plug
J403	1	1	1	YP10001130	Plug
J404	1	1	1	YP10001130	Plug
J405	1	1	1	YP10001130	Plug
J406	1	1	1	YP10001130	Plug
J407	1	1	1	YP10001130	Plug
J408	1	1	1	YP10001130	Plug
J409	1	1	1	YP10001130	Plug
J410	1	1	1	YP10001130	Plug
J411	1	1	1	YP10001130	Plug
J412	1	1	1	YP10001130	Plug
J413	1	1	1	YP10001130	Plug
J414	1	1	1	YP10001130	Plug
J415	1	1	1	YP10001130	Plug
J416	1	1	1	YP10001130	Plug
J417	1	1	1	YP10001130	Plug
J418	1	1	1	YP10001130	Plug
J419	1	1	1	YP10001130	Plug
J420	1	1	1	YP10001130	Plug
J421	1	1	1	YP10001130	Plug
J422	1	1	1	YP10001130	Plug
J423	1	1	1	YP10001130	Plug
J424	1	1	1	YP10001130	Plug
J425	1	1	1	YP10001130	Plug
J426	1	1	1	YP10001130	Plug
J427	1	1	1	YP10001130	Plug
J428	1	1	1	YP10001130	Plug
J429	1	1	1	YP10001130	Plug
J430	1	1	1	YP10001130	Plug
J431	1	1	1	YP10001130	Plug
J432	1	1	1	YP10001130	Plug
J433	1	1	1	YP10001130	Plug
J434	1	1	1	YP10001130	Plug
J435	1	1	1	YP10001130	Plug
J436	1	1	1	YP10001130	Plug
J437	1	1	1	YP10001130	Plug
J438	1	1	1	YP10001130	Plug
J439	1	1	1	YP10001130	Plug
J440	1	1	1	YP10001130	Plug
J441	1	1	1	YP10001130	Plug
J442	1	1	1	YP10001130	Plug
J443	1	1	1	YP10001130	Plug
J444	1	1	1	YP10001130	Plug
J445	1	1	1	YP10001130	Plug
J446	1	1	1	YP10001130	Plug
P400	1	1	1	YK22130230	P.W. Board, Phono Amp
	1	1		ZZ22111230	P.W. Board Assembly
			1	ZZ22118230	P.W. Board Assembly
Q401	1	1	1	HT108722D0	Transistor, 2SA872A D or E
Q402	1	1	1	HT108722D0	Transistor, 2SA872A D or E
Q403	1	1	1	HT108722D0	Transistor, 2SA872A D or E
Q404	1	1	1	HT108722D0	Transistor, 2SA872A D or E
Q405	1	1	1	HT109122C0	Transistor, 2SA912 S or T
Q406	1	1	1	HT318852D0	Transistor, 2SC1885 S or T
Q407	1	1	1	HT109122C0	Transistor, 2SA912 S or T
Q408	1	1	1	HT318852D0	Transistor, 2SC1885 S or T
R401	1	1	1	RN05823140	Res., Fixed, 82kΩ ±5%, ¼W
R402	1	1	1	RN05823140	Res., Fixed, 82kΩ ±5%, ¼W
R403	1	1	1	RN05154140	Res., Fixed, 150kΩ ±5%, ¼W

U: For U.S.A.
C: For Canada
E: For Europe

REF. DESIG.	Q'TY			PART NO.	DESCRIPTION
	U	C	E		
R404	1	1	1	RN05154140	Res., Fixed, 150kΩ ±5%, ¼W
R405	1	1	1	RT05222140	Res., Fixed, 2.2kΩ ±5%, ¼W
R406	1	1	1	RT05222140	Res., Fixed, 2.2kΩ ±5%, ¼W
R407	1	1	1	RN05123140	Res., Fixed, 12kΩ ±5%, ¼W
R408	1	1	1	RN05123140	Res., Fixed, 12kΩ ±5%, ¼W
R409	1	1	1	RN05154140	Res., Fixed, 150kΩ ±5%, ¼W
R410	1	1	1	RN05154140	Res., Fixed, 150kΩ ±5%, ¼W
R411	1	1	1	RT02911140	Res., Fixed, 910Ω ±2%, ¼W
R412	1	1	1	RT02911140	Res., Fixed, 910Ω ±2%, ¼W
R413	1	1	1	RT02105140	Res., Fixed, 1MΩ ±2%, ¼W
R414	1	1	1	RT02105140	Res., Fixed, 1MΩ ±2%, ¼W
R415	1	1	1	RT05683140	Res., Fixed, 68kΩ ±5%, ¼W
R416	1	1	1	RT05683140	Res., Fixed, 68kΩ ±5%, ¼W
R417	1	1	1	RT05431140	Res., Fixed, 430Ω ±5%, ¼W
R418	1	1	1	RT05431140	Res., Fixed, 430Ω ±5%, ¼W
R419	1	1	1	RT05111140	Res., Fixed, 110Ω ±5%, ¼W
R420	1	1	1	RT05111140	Res., Fixed, 110Ω ±5%, ¼W
R421	1	1	1	RT05111140	Res., Fixed, 110Ω ±5%, ¼W
R422	1	1	1	RT05111140	Res., Fixed, 110Ω ±5%, ¼W
R423	1	1	1	RT05152140	Res., Fixed, 1.5kΩ ±5%, ¼W
R424	1	1	1	RT05152140	Res., Fixed, 1.5kΩ ±5%, ¼W
R425	1	1	1	RT05363140	Res., Fixed, 36kΩ ±5%, ¼W
R426	1	1	1	RT05363140	Res., Fixed, 36kΩ ±5%, ¼W
R427	1	1	1	RT05331140	Res., Fixed, 330Ω ±5%, ¼W
R428	1	1	1	RT05331140	Res., Fixed, 330Ω ±5%, ¼W
R429	1	1	1	RT05274140	Res., Fixed, 270kΩ ±5%, ¼W
R430	1	1	1	RT05274140	Res., Fixed, 270kΩ ±5%, ¼W
R431	1	1	1	RT05470140	Res., Fixed, 47Ω ±5%, ¼W
R432	1	1	1	RT05470140	Res., Fixed, 47Ω ±5%, ¼W
S401			1	SR14060030	Rotary Switch
S401			1	SR16060010	Rotary Switch
C701	1	1	1	EE47502540	Cap., Elect., 4.7μF, 25V
C704	1	1	1	DD16201010	Cap., Ceramic, 200pF, 50V
C706	1	1	1	EE47601640	Cap., Elect., 47μF, 16V
C707	1	1	1	DD11050500	Cap., Ceramic, 5pF, 500V
C710	1	1	1	EA47605090	Cap., Elect., 47μF, 50V
C711	1	1	1	DF16104050	Cap., Film, 0.1μF, 50V
C712	1	1	1	DK16101500	Cap., Ceramic, 100pF, 500V
C713	1	1	1	DK16101500	Cap., Ceramic, 100pF, 500V
C714	1	1	1	DK16221510	Cap., Ceramic, 220pF, 500V
C715	1	1	1	DK16221510	Cap., Ceramic, 220pF, 500V
C716	1	1	1	EE10601640	Cap., Elect., 10μF, 16V
C717	1	1	1	EE10601640	Cap., Elect., 10μF, 16V
C718	1	1	1	DF15104050	Cap., Film, 0.1μF, 50V
C719	1	1	1	DF15104050	Cap., Film, 0.1μF, 50V
C720	1	1	1	DF17103050	Cap., Film, 0.01μF, 50V
C721	1	1	1	DF17103050	Cap., Film, 0.01μF, 50V
C722	1	1	1	EA22705090	Cap., Elect., 220μF, 50V
C723	1	1	1	EA22705090	Cap., Elect., 220μF, 50V
C724	1	1	1	DF17104520	Cap., Film, 0.1μF, 200V
C751	1	1	1	EE47502540	Cap., Elect., 4.7μF, 25V
C754	1	1	1	DD16201010	Cap., Ceramic, 200pF, 50V
C756	1	1	1	EE47601640	Cap., Elect., 47μF, 16V
C757	1	1	1	DD11050500	Cap., Ceramic, 5pF, 500V
C760	1	1	1	EA47605090	Cap., Elect., 47μF, 50V
C761	1	1	1	DF16104050	Cap., Film, 0.1μF, 50V
C762	1	1	1	DK16101500	Cap., Ceramic, 100pF, 500V
C763	1	1	1	DK16101500	Cap., Ceramic, 100pF, 500V
C764	1	1	1	DK16221510	Cap., Ceramic, 220pF, 500V
C765	1	1	1	DK16221510	Cap., Ceramic, 220pF, 500V
C766	1	1	1	EE10601640	Cap., Elect., 10μF, 16V

REF. DESIG.	Q'TY			PART NO.	DESCRIPTION
	U	C	E		
C767	1	1	1	EE10601640	Cap., Elect., 10μF, 16V
C768	1	1	1	DF15104050	Cap., Film, 0.1μF, 50V
C769	1	1	1	DF15104050	Cap., Film, 0.1μF, 50V
C770	1	1	1	DF17103050	Cap., Film, 0.01μF, 50V
C771	1	1	1	DF17103050	Cap., Film, 0.01μF, 50V
C772	1	1	1	EA22705090	Cap., Elect., 220μF, 50V
C773	1	1	1	EA22705090	Cap., Elect., 220μF, 50V
C774	1	1	1	DF17104520	Cap., Film, 0.1μF, 200V
J709	1	1	1	YP10001130	Plug
J710	1	1	1	YP10001130	Plug
J711	1	1	1	YP10001130	Plug
J712	1	1	1	YP10001130	Plug
J713	1	1	1	YP10001130	Plug
J714	1	1	1	YP10001130	Plug
J715	1	1	1	YP10001130	Plug
J716	1	1	1	YP10001130	Plug
J717	1	1	1	YP10001130	Plug
J718	1	1	1	YP10001130	Plug
J719	1	1	1	YP10001130	Plug
J720	1	1	1	YP06001040	Plug
J721	1	1	1	YP06001050	Plug
J759	1	1	1	YP10001130	Plug
J760	1	1	1	YP10001130	Plug
J761	1	1	1	YP10001130	Plug
J762	1	1	1	YP10001130	Plug
J763	1	1	1	YP10001130	Plug
J764	1	1	1	YP10001130	Plug
J765	1	1	1	YP10001130	Plug
J766	1	1	1	YP10001130	Plug
J767	1	1	1	YP10001130	Plug
J768	1	1	1	YP10001130	Plug
J769	1	1	1	YP10001130	Plug
J770	1	1	1	YP06001040	Plug
J771	1	1	1	YP06001050	Plug
L701	1	1	1	LC22620010	Choke Coil
L751	1	1	1	LC22620010	Choke Coil
P700	1	1	1	YG22110010	P.W. Board, Main Amp
	1	1	1	ZZ22110010	P.W. Board Assembly
Q701	1	1	1	HT107222B0	Transistor, 2SA722 T or U
Q702	1	1	1	HT107222B0	Transistor, 2SA722 T or U
Q703	1	1	1	HV00003120	Varistor, MV-13
Q704	1	1	1	HV00003120	Varistor, MV-13
Q705	1	1	1	HT318852C0	Transistor, 2SC1885 R or S
Q706	1	1	1	HT312222B0	Transistor, 2SC1222 E or U
Q707	1	1	1	HT319403A0	Transistor, 2SC1940 K, L or M
Q708	1	1	1	HT109153A0	Transistor, 2SA915 K, L or M
Q709	1	1	1	HT404153A0	Transistor, 2SD415 P, Q or R
Q710	1	1	1	HT205493A0	Transistor, 2SB549 P, Q or R
Q711	1	1	1	HD20001210	Diode, 1S2473 Yel
Q712	1	1	1	HD20001210	Diode, 1S2473 Yel
Q713	1	1	1	HD20001210	Diode, 1S2473 Yel
Q714	1	1	1	HD20001210	Diode, 1S2473 Yel
Q715	1	1	1	HD20001210	Diode, 1S2473 Yel
Q716	1	1	1	HD20001210	Diode, 1S2473 Yel
Q717	1	1	1	HT309451Q0	Transistor, 2SC945 Q
Q718	1	1	1	HT107331Q0	Transistor, 2SA733 Q
Q719	1	1	1	HD20005010	Diode, W06B Grn
Q720	1	1	1	HD20005010	Diode, W06B Grn
Q751	1	1	1	HT107222E0	Transistor, 2SA722 T or U

U: For U.S.A.
C: For Canada
E: For Europe

REF. DESIG.	Q'TY			PART NO.	DESCRIPTION
	U	C	E		
Q752	1	1	1	HT107222B0	Transistor, 2SA722 T or U
Q753	1	1	1	HV00003120	Varistor, MV-13
Q754	1	1	1	HV00003120	Varistor, MV-13
Q755	1	1	1	HT318852C0	Transistor, 2SC1885 R or S
Q756	1	1	1	HT312222B0	Transistor, 2SC1222 E or U
Q757	1	1	1	HT319403A0	Transistor, 2SC1940 K, L or M
Q758	1	1	1	HT109153A0	Transistor, 2SA915 K, L or M
Q759	1	1	1	HT404153A0	Transistor, 2SD415 P, Q or R
Q760	1	1	1	HT205493A0	Transistor, 2SB549 P, Q or R
Q761	1	1	1	HD20001210	Diode, 1S2473 Yel
Q762	1	1	1	HD20001210	Diode, 1S2473 Yel
Q763	1	1	1	HD20001210	Diode, 1S2473 Yel
Q764	1	1	1	HD20001210	Diode, 1S2473 Yel
Q765	1	1	1	HD20001210	Diode, 1S2473 Yel
Q766	1	1	1	HD20001210	Diode, 1S2473 Yel
Q767	1	1	1	HT309451Q0	Trasistor, 2SC945 Q
Q768	1	1	1	HT107331Q0	Transistor, 2SA733 Q
Q769	1	1	1	HD20005010	Diode, W06B Grn
Q770	1	1	1	HD20005010	Diode, W06B Grn
R701	1	1	1	RT05474140	Res., Fixed, 470kΩ ±5%, ¼W
R702	1	1	1	RT05102140	Res., Fixed, 1kΩ ±5%, ¼W
R703	1	1	1	RT05363140	Res., Fixed, 36kΩ ±5%, ¼W
R704	1	1	1	RT05223140	Res., Fixed, 22kΩ ±5%, ¼W
R705	1	1	1	RT05102140	Res., Fixed, 1kΩ ±5%, ¼W
R706	1	1	1	RT05101140	Res., Fixed, 100Ω ±5%, ¼W
R708	1	1	1	RT05242140	Res., Fixed, 2.4kΩ ±5%, ¼W
R709	1	1	1	RT05274140	Res., Fixed, 270kΩ ±5%, ¼W
R710	1	1	1	RA04720060	Res., Semifixed, 4.7kΩ(B)
R711	1	1	1	RT05363140	Res., Fixed, 36kΩ ±5%, ¼W
R712	1	1	1	RT05103140	Res., Fixed, 10kΩ ±5%, ¼W
R713	1	1	1	RT05103140	Res., Fixed, 10kΩ ±5%, ¼W
R714	1	1	1	GF05220140	Res., Fixed, 22Ω ±5%, ¼W
R715	1	1	1	RT05681140	Res., Fixed, 680Ω ±5%, ¼W
R716	1	1	1	RA04710040	Res., Semifixed, 470Ω(B)
R717	1	1	1	RT05331140	Res., Fixed, 330Ω ±5%, ¼W
R718	1	1	1	RT05472140	Res., Fixed, 4.7kΩ ±5%, ¼W
R719	1	1	1	GF05182140	Res., Fixed, 1.8kΩ ±5%, ¼W
R720	1	1	1	GF05101140	Res., Fixed, 100Ω ±5%, ¼W
R721	1	1	1	GF05101140	Res., Fixed, 100Ω ±5%, ¼W
R722	1	1	1	GJ05562010	Res., Fixed, 5.6kΩ ±5%, 1W
R723	1	1	1	GJ05562010	Res., Fixed, 5.6kΩ ±5%, 1W
R724	1	1	1	GF05100140	Res., Fixed, 10Ω ±5%, ¼W
R725	1	1	1	GF05100140	Res., Fixed, 10Ω ±5%, ¼W
R726	1	1	1	GF05301120	Res., Fixed, 300Ω ±5%, ¼W
R727	1	1	1	GW10472050	Res., Fixed, 0.47Ω ±10%, 5W
R728	1	1	1	GW10472050	Res., Fixed, 0.47Ω ±10%, 5W
R729	1	1	1	RT05201140	Res., Fixed, 200Ω ±5%, ¼W
R730	1	1	1	RT05161140	Res., Fixed, 160Ω ±5%, ¼W
R731	1	1	1	RT05301140	Res., Fixed, 300Ω ±5%, ¼W
R732	1	1	1	GF05242140	Res., Fixed, 2.4kΩ ±5%, ¼W
R733	1	1	1	RT05201140	Res., Fixed, 200Ω ±5%, ¼W
R734	1	1	1	RT05161140	Res., Fixed, 160Ω ±5%, ¼W
R735	1	1	1	RT05301140	Res., Fixed, 300Ω ±5%, ¼W
R736	1	1	1	GF05242140	Res., Fixed, 2.4kΩ ±5%, ¼W
R737	1	1	1	RT05363140	Res., Fixed, 36kΩ ±5%, ¼W
R740	1	1	1	RC10022120	Res., Fixed, 2.2Ω ±10%, ½W
R741	1	1	1	GJ05100020	Res., Fixed, 10Ω ±5%, 2W
R742	1	1	1	GF05101140	Res., Fixed, 100Ω ±5%, ¼W
R743	1	1	1	GF05220140	Res., Fixed, 22Ω ±5%, ¼W
R751	1	1	1	RT05474140	Res., Fixed, 470kΩ ±5%, ¼W
R752	1	1	1	RT05102140	Res., Fixed, 1kΩ ±5%, ¼W

REF. DESIG.	Q'TY			PART NO.	DESCRIPTION
	U	C	E		
R753	1	1	1	RT05363140	Res., Fixed, 36kΩ ±5%, ¼W
R754	1	1	1	RT05223140	Res., Fixed, 22kΩ ±5%, ¼W
R755	1	1	1	RT05102140	Res., Fixed, 1kΩ ±5%, ¼W
R756	1	1	1	RT05101140	Res., Fixed, 100Ω ±5%, ¼W
R758	1	1	1	RT05242140	Res., Fixed, 2.4kΩ ±5%, ¼W
R759	1	1	1	RT05274140	Res., Fixed, 270kΩ ±5%, ¼W
R760	1	1	1	RA04720060	Res., Semifixed, 4.7kΩ(B)
R761	1	1	1	RT05363140	Res., Fixed, 36kΩ ±5%, ¼W
R762	1	1	1	RT05103140	Res., Fixed, 10kΩ ±5%, ¼W
R763	1	1	1	RT05103140	Res., Fixed, 10kΩ ±5%, ¼W
R764	1	1	1	GF05220140	Res., Fixed, 22Ω ±5%, ¼W
R765	1	1	1	RT05681140	Res., Fixed, 680Ω ±5%, ¼W
R766	1	1	1	RA04710040	Res., Semifixed, 470Ω(B)
R767	1	1	1	RT05331140	Res., Fixed, 330Ω ±5%, ¼W
R768	1	1	1	RT05472140	Res., Fixed, 4.7kΩ ±5%, ¼W
R769	1	1	1	GF05182140	Res., Fixed, 1.8kΩ ±5%, ¼W
R770	1	1	1	GF05101140	Res., Fixed, 100Ω ±5%, ¼W
R771	1	1	1	GF05101140	Res., Fixed, 100Ω ±5%, ¼W
R772	1	1	1	GJ05562010	Res., Fixed, 5.6kΩ ±5%, 1W
R773	1	1	1	GJ05562010	Res., Fixed, 5.6kΩ ±5%, 1W
R774	1	1	1	GF05100140	Res., Fixed, 10Ω ±5%, ¼W
R775	1	1	1	GF05100140	Res., Fixed, 10Ω ±5%, ¼W
R776	1	1	1	GF05301120	Res., Fixed, 300Ω ±5%, ¼W
R777	1	1	1	GW10472050	Res., Fixed, 0.47Ω ±10%, 5W
R778	1	1	1	GW10472050	Res., Fixed, 0.47Ω ±10%, 5W
R779	1	1	1	RT05201140	Res., Fixed, 200Ω ±5%, ¼W
R780	1	1	1	RT05161140	Res., Fixed, 160Ω ±5%, ¼W
R781	1	1	1	RT05301140	Res., Fixed, 300Ω ±5%, ¼W
R782	1	1	1	GF05242140	Res., Fixed, 2.4kΩ ±5%, ¼W
R783	1	1	1	RT05201140	Res., Fixed, 200Ω ±5%, ¼W
R784	1	1	1	RT05161140	Res., Fixed, 160Ω ±5%, ¼W
R785	1	1	1	RT05301140	Res., Fixed, 300Ω ±5%, ¼W
R786	1	1	1	GE05242140	Res., Fixed, 2.4kΩ ±5%, ¼W
R787	1	1	1	RT05363140	Res., Fixed, 36kΩ ±5%, ¼W
R790	1	1	1	RC10022120	Res., Fixed, 2.2Ω ±10%, ½W
R791	1	1	1	GJ05100020	Res., Fixed, 10Ω ±5%, 2W
R792	1	1	1	GF05101140	Res., Fixed, 100Ω ±5%, ¼W
R793	1	1	1	GF05220140	Res., Fixed, 22Ω ±5%, ¼W
C801	1	1	1	EA47706310	Cap., Elect., 470μF, 63V
C802	1	1	1	EA33706310	Cap., Elect., 330μF, 63V
C803	1	1	1	EA10701690	Cap., Elect., 100μF, 16V
C804	1	1	1	EA10605090	Cap., Elect., 10μF, 50V
C805	1	1	1	DK17103010	Cap., Ceramic, 0.01μF
C806	1	1	1	EA10602590	Cap., Elect., 10μF, 25V
C807	1	1	1	DK17103010	Cap., Ceramic, 0.01μF
C808	1	1	1	DK17103010	Cap., Ceramic, 0.01μF
C809	1	1	1	EA33705090	Cap., Elect., 330μF, 50V
C810	1	1	1	EA47701690	Cap., Elect., 470μF, 16V
C811	1	1	1	DK17103010	Cap., Ceramic, 0.01μF
C812	1	1	1	EA10605090	Cap., Elect., 10μF, 50V
C813	1	1	1	EA10701690	Cap., Elect., 100μF, 16V
C814	1	1	1	DK17103010	Cap., Ceramic, 0.01μF
C815	1	1	1	EA10702590	Cap., Elect., 100μF, 25V
C816	1	1	1	DK17103010	Cap., Ceramic, 0.01μF
C817	1	1	1	EA47505090	Cap., Elect., 4.7μF, 50V
C818	1	1	1	EA47601690	Cap., Elect., 47μF, 16V
C819	1	1	1	EA22701090	Cap., Elect., 220μF, 10V
C820	1	1	1	EA47701690	Cap., Elect., 470μF, 16V
C821	1	1	1	DK18103510	Cap., Ceramic, 0.01μF
C822	1	1	1	DK18103510	Cap., Ceramic, 0.01μF
J801	1	1	1	YP10001130	Plug

U: For U.S.A.
 C: For Canada
 E: For Europe

REF. DESIG.	Q'TY			PART NO.	DESCRIPTION
	U	C	E		
J802	1	1	1	YP10001130	Plug
J803	1	1	1	YP10001130	Plug
J804	1	1	1	YP10001130	Plug
J805	1	1	1	YP10001130	Plug
J806	1	1	1	YP10001130	Plug
J807	1	1	1	YP10001130	Plug
J808	1	1	1	YP10001130	Plug
J809	1	1	1	YP10001130	Plug
J810	1	1	1	YP10001130	Plug
J811	1	1	1	YP10001130	Plug
J812	1	1	1	YP10001130	Plug
J813	1	1	1	YP10001130	Plug
J814	1	1	1	YP10001130	Plug
J815	1	1	1	YP10001130	Plug
J816	1	1	1	YP10001130	Plug
J817	1	1	1	YP10001130	Plug
J818	1	1	1	YP10001130	Plug
J819	1	1	1	YP10001130	Plug
J820	1	1	1	YP10001130	Plug
L801	1	1	1	LY40240050	Relay, 24V
P800	1	1	1	YK22130240	P.W. Board, Power Supply
	1	1	1	ZZ22130240	P.W. Board Assembly
Q801	1	1	1	HT313842A0	Transistor, 2SC1384 P or Q
Q802	1	1	1	HT313183A0	Transistor, 2SC1318 P, Q or R.
Q803	1	1	1	HT106842A0	Transistor, 2SA684 P or Q
Q804	1	1	1	HT107332B0	Transistor, 2SA733 Q or R
Q805	1	1	1	HD30047090	Zener, WZ-192, 19V
Q806	1	1	1	HT313842A0	Transistor, 2SC1384 P or Q
Q807	1	1	1	HT106842A0	Transistor, 2SA684 P or Q
Q808	1	1	1	HT403302A0	Transistor, 2SD330 D or E
Q809	1	1	1	HT30027090	Transistor, WZ-140, 14V
Q810	1	1	1	HT309452A0	Transistor, 2SC945 Q or R
Q811	1	1	1	HT313183A0	Transistor, 2SC1318 P, Q or R
Q812	1	1	1	HT313183A0	Transistor, 2SC1318 P, Q or R
Q813	1	1	1	HD20003210	Diode, 1S-2471
Q814	1	1	1	HD20001210	Diode, 1S-2473
Q815	1	1	1	HD20013100	Diode, 10D-1
Q816	1	1	1	HD20011030	Diode, DS131-B
Q817	1	1	1	HD20012030	Diode, DS132-B
Q818	1	1	1	HD20011030	Diode, DS131-B
R801	1	1	1	GF05100140	Res., Fixed, 10Ω ±5%, ¼W
R802	1	1	1	RT05821140	Res., Fixed, 820Ω ±5%, ¼W
R803	1	1	1	RT05821140	Res., Fixed, 820Ω ±5%, ¼W
R804	1	1	1	RT05222140	Res., Fixed, 2.2kΩ ±5%, ¼W
R805	1	1	1	RT05752140	Res., Fixed, 7.5kΩ ±5%, ¼W
R806	1	1	1	RT05103140	Res., Fixed, 10kΩ ±5%, ¼W
R807	1	1	1	RT05203140	Res., Fixed, 20kΩ ±5%, ¼W
R808	1	1	1	RT05434140	Res., Fixed, 430kΩ ±5%, ¼W
R809	1	1	1	GF05470140	Res., Fixed, 47Ω ±5%, ¼W
R810	1	1	1	RT05821140	Res., Fixed, 820Ω ±5%, ¼W
R811	1	1	1	RT05821140	Res., Fixed, 820Ω ±5%, ¼W
R812	1	1	1	RT05183140	Res., Fixed, 18kΩ ±5%, ¼W
R813	1	1	1	RT05103140	Res., Fixed, 10kΩ ±5%, ¼W
R814	1	1	1	RT05752140	Res., Fixed, 7.5kΩ ±5%, ¼W
R815	1	1	1	GF05301140	Res., Fixed, 300Ω ±5%, ¼W
R816	1	1	1	GF05242140	Res., Fixed, 2.4kΩ ±5%, ¼W
R817	1	1	1	RT05101140	Res., Fixed, 100Ω ±5%, ¼W
R818	1	1	1	GS10151050	Res., Fixed, 150Ω ±10%, 5W
R819	1	1	1	GF05301140	Res., Fixed, 300Ω ±5%, ¼W

REF. DESIG.	Q'TY			PART NO.	DESCRIPTION
	U	C	E		
R820	1	1	1	RT05682140	Res., Fixed, 6.8kΩ ±5%, ¼W
R821	1	1	1	RT05184140	Res., Fixed, 180kΩ ±5%, ¼W
R822	1	1	1	RT05393140	Res., Fixed, 39kΩ ±5%, ¼W
R824	1	1	1	RT05103140	Res., Fixed, 10kΩ ±5%, ¼W
R825	1	1	1	RT05273140	Res., Fixed, 27kΩ ±5%, ¼W
R826	1	1	1	RT05223140	Res., Fixed, 22kΩ ±5%, ¼W
R827	1	1	1	GU05562120	Res., Fixed, 5.6kΩ ±5%, ¼W
R828	1	1	1	GU05562120	Res., Fixed, 5.6kΩ ±5%, ¼W

12. TECHNICAL SPECIFICATIONS

[FOR U.S.A. MODEL ONLY]

AMPLIFIER SECTION:

RATED POWER OUTPUT, MINIMUM CONTINUOUS AVERAGE POWER PER CHANNEL, BOTH CHANNELS DRIVEN	65 W
POWER BAND	20 Hz to 20 kHz
TOTAL HARMONIC DISTORTION	0.05%
LOAD IMPEDANCE	8 ohms
RATED POWER OUTPUT, MINIMUM CONTINUOUS AVERAGE POWER PER CHANNEL, BOTH CHANNELS DRIVEN	83 W
POWER BAND	20 Hz to 20 kHz
TOTAL HARMONIC DISTORTION	0.1%
LOAD IMPEDANCE	4 ohms

I.M. Distortion
(I.H.F. method, 60 Hz and 70 kHz mixed 4:1 at rated power output)

at 8 ohm load impedance	0.05%
at 4 ohm load impedance	0.1%
Damping Factor (at 20 Hz)	55
Sensitivity (at MAIN IN)	1.5 V
Impedance (at MAIN IN)	33 kohms
Frequency Response for Power Amp Only (at 1 Watt output, 20 Hz to 20 kHz)	±0.2 dB

PREAMPLIFIER SECTION:

Phono

Input Overload at 1 kHz	200 mV
Equivalent Input Noise	1.25 µV
Dynamic Range (Dynamic Range is the ratio of input overload to equivalent input noise)	102 dB
Input Sensitivity	1.8 mV
Input Impedance	47 kohms
Input Capacitance	100 pF
Frequency Response, RIAA 20 Hz to 20 kHz	±0.5 dB
Signal-to-Noise Ratio (at rated output and 7.75 mV input)	78 dB
High Level (Aux and Tape)	
Input Sensitivity	180 mV
Input Impedance	20 kohms
Frequency Response (includes power amp)	10 Hz to 60 kHz ±1.25 dB
Signal-to-Noise Ratio (ref. to rated output and 775 mV input)	90 dB
Output Levels	
Tape Out (ref. 7.75 mV at Phono inputs)	775 mV
Pre-Out (ref. 180 mV at Aux inputs)	1.5 V
(ref. 500 mV at Aux inputs, main amp disconnected)	4.2 V
Output Impedance	
Tape Out	600 ohms
Pre-Out	900 ohms

FM TUNER SECTION:

Sensitivity	
IHF Usable	10.3 dBf (1.8 µV)
IHF 50 dB Quieting (Mono)	14.8 dBf (3.0 µV)
(Stereo)	36 dBf (35 µV)
Quieting Slope (Mono)	
RF Input for 30 dB Quieting	8.2 dBf (1.4 µV)
Quieting at:	
20 dBf (5.5 µV)	58 dB
25 dBf (10 µV)	63 dB
40 dBf (55 µV)	72 dB
65 dBf (1000 µV)	76 dB
Quieting Slope (Stereo)	
Quieting at:	
30 dBf (17 µV)	43 dB
40 dBf (55 µV)	53 dB
50 dBf (173 µV)	60 dB
65 dBf (1000 µV)	70 dB
Distortion (Mono) at 65 dBf (1000 µV)	
100 Hz	0.25%
1000 Hz	0.15%
6000 Hz	0.3%
Distortion (Stereo) at 65 dBf (1000 µV)	
100 Hz	0.35%
1000 Hz	0.3%
6000 Hz	0.5%

Distortion (Mono and Stereo)	
at 50 dB Quieting, 1000 Hz	0.6%
Hum and Noise	
at 65 dBf (1000 µV)	
Mono	74 dB
Frequency Response	
30 Hz to 15 kHz	
Mono	+0.2 dB, -1.5 dB
Stereo	±1.5 dB
Capture Ratio at 65 dBf (1000 µV)	1.0 dB
Alternate Channel Selectivity	80 dB
Spurious Response Rejection	100 dB
Image Response Rejection	90 dB
I.F. Rejection (Balanced)	100 dB
A.M. Suppression	55 dB
Stereo Separation	
100 Hz	42 dB
1000 Hz	50 dB
10 kHz	42 dB
Subcarrier Rejection	70 dB

AM TUNER SECTION:

IHF Usable Sensitivity	12 µV
Distortion (THD), 30% Modulation	0.4%
Signal-to-Noise Ratio	54 dB
Alternate Channel Selectivity	46 dB
Image Rejection	75 dB
Spurious Response Rejection	85 dB
I.F. Rejection	75 dB

GENERAL:

Power Requirements	120 V AC 60 Hz
Power Consumption at rated output, both channels operating	280 W
Idling Power (Volume Control at zero)	50 W
Dimensions:	
Panel Width	440 mm (17-5/16")
Panel Height	137 mm (5-3/8")
Depth	362 mm (14-1/2")
Weight:	
Unit alone	14.5 kg (31.9 lbs)
Packed for Shipment	17 kg (37.4 lbs)

[FOR EUROPEAN MODEL ONLY]

AUDIO SECTION:

POWER OUTPUT AT 1% DISTORTION	119 W
RATED POWER OUTPUT, 1 kHz	92 W
TOTAL HARMONIC DISTORTION AT RATED POWER OUTPUT, 1 kHz	0.1%
I.M. DISTORTION AT RATED POWER OUTPUT (I.H.F. METHOD, 300 Hz AND 10 kHz MIXED 4:1 AT RATED POWER OUTPUT)	0.1%
POWER BANDWIDTH (½ RATED POWER OUTPUT)	8 Hz – 30 kHz
LOAD IMPEDANCE	4 ohms
POWER OUTPUT AT 1% DISTORTION	85 W
RATED POWER OUTPUT, 1 kHz	72 W
TOTAL HARMONIC DISTORTION AT RATED POWER OUTPUT, 1 kHz	0.05%
I.M. DISTORTION AT RATED POWER OUTPUT (I.H.F. METHOD, 300 Hz AND 10 kHz MIXED 4:1 AT RATED POWER OUTPUT)	0.1%
POWER BANDWIDTH (½ RATED POWER OUTPUT)	8 Hz – 30 kHz
LOAD IMPEDANCE	8 ohms

Damping Factor, Speaker Output	
40 Hz	60
1 kHz	60
12.5 kHz	40
Frequency Response	
Phono ±2 dB	18 Hz – 30 kHz
Aux ±1.5 dB	10 Hz – 40 kHz
Main In ±1.5 dB	8 Hz – 45 kHz
Signal-to-Noise Ratio, 1 kHz	
Phono	50 dB
Aux	50 dB
Main In	55 dB
Input Sensitivity, 1 kHz (Rated Input Voltage)	
Phono	1.8 mV
Aux	180 mV
Main In	1.5 V
Input Impedance, 1 kHz	
Phono	47 kohms
Aux	20 kohms
Main In	33 kohms
Phono Equivalent Noise	1.8 µV
Phono Dynamic Range	98 dB
Phono Input Capacitance	100 pF
Channel Balance	
Phono 0 – -40 dB	2.5 dB
Aux 40 Hz – 16 kHz	2.0 dB
Main In	1.0 dB
Interchannel Crosstalk	
Phono 1 kHz	38 dB
250 Hz – 10 kHz	33 dB
Aux 1 kHz	45 dB
250 Hz – 10 kHz	33 dB
Tape 1 kHz	45 dB
250 Hz – 10 kHz	33 dB
Main In 1 kHz	55 dB
250 Hz – 10 kHz	50 dB
Intersource Crosstalk (Worst Point)	
1 kHz	45 dB
250 Hz – 10 kHz	33 dB
Output Voltage, 1 kHz	
Tape Out	0.18 V
Pre-Out	1.5 V
Output Impedance, 1 kHz	
Tape Out	500 ohms
Pre Out	200 ohms
Overload Margin, 1 kHz	
Phono	40 dB
Aux	50 dB
Power Consumption	
Idling	45 W
Rated Power, 1 kHz	290 W

FM TUNER SECTION:

Frequency Range	87.5 – 108 MHz
Usable Sensitivity 40 kHz Deviation, 98 MHz	
Mono, S/N 26 dB	1.4 µV
Stereo, S/N 46 dB	42 µV
Alternate Channel Selectivity, 98 MHz ±300 kHz	67 dB
Image Response Rejection, 98 MHz	90 dB
IF Rejection, 98 MHz	80 dB
Spurious Response Rejection, 98 MHz	90 dB
AM Suppression, 98 MHz	55 dB

Signal-to-Noise Ratio, 98 MHz	
Unweighted: Mono	65 dB
Stereo	62 dB
Weighted: Mono	69 dB
Stereo	65 dB
Pilot Signal & Subcarrier Rejection	
19 kHz	65 dB
38 kHz	70 dB
Total Harmonic Distortion, 98 MHz	
Mono	0.15%
Stereo	0.25%
Frequency Response	
30 Hz – 15 kHz	+0.2, -1.0 dB
Separation	
250 Hz – 6.3 kHz	43 dB
6.3 – 12.5 kHz	38 dB
Channel Balance	0.3 dB
Output Voltage, 1 kHz	910 mV
Output Impedance, 1 kHz	150 ohms
Acceptable Load Impedance, 1 kHz	47 kohms
Antenna Terminals	
Balanced	300 ohms
Unbalanced	75 ohms

AM TUNER SECTION:

Frequency Range	515 – 1650 kHz
Usable Sensitivity (26 dB S/N 30% Mod., 1 MHz)	20 µV
Selectivity, 1 MHz ±9 kHz	20 dB
Image Rejection, 1 MHz	43 dB
IF Rejection, 1 MHz	23 dB
Spurious Response Rejection, 1 MHz	85 dB
Signal-to-Noise Ratio, 1 MHz	55 dB
Frequency Response, 1 MHz ±3 dB	40 Hz – 2.3 kHz
Total Harmonic Distortion, 1 MHz	0.4%

GENERAL:

Power Requirements	220 V AC, 50 Hz
(E and N versions are featuring an external voltage selector for use on 110/120/240 V. Other versions can be converted by a qualified technician to operate on 110/120/240 V.)	
Power Consumption at Rated Output, Both Channels	
Operating	280 W ± 20 W
Idling Power	45 W ± 10 W
Semiconductor Complement	
Integrated Circuits	4
Transistors	65
Diodes	41
Field Effect Transistors	2
Dimensions	
Panel Width	17-5/16" (440 mm)
Panel Height	5-3/8" (137 mm)
Depth	14-1/2" (362 mm)
Weight	
Unit alone	31.9 lbs (14.5 kg)
Packed for shipment	37.4 lbs (17 kg)

13. SCHEMATIC DIAGRAMS - U.S.A. & CANADA

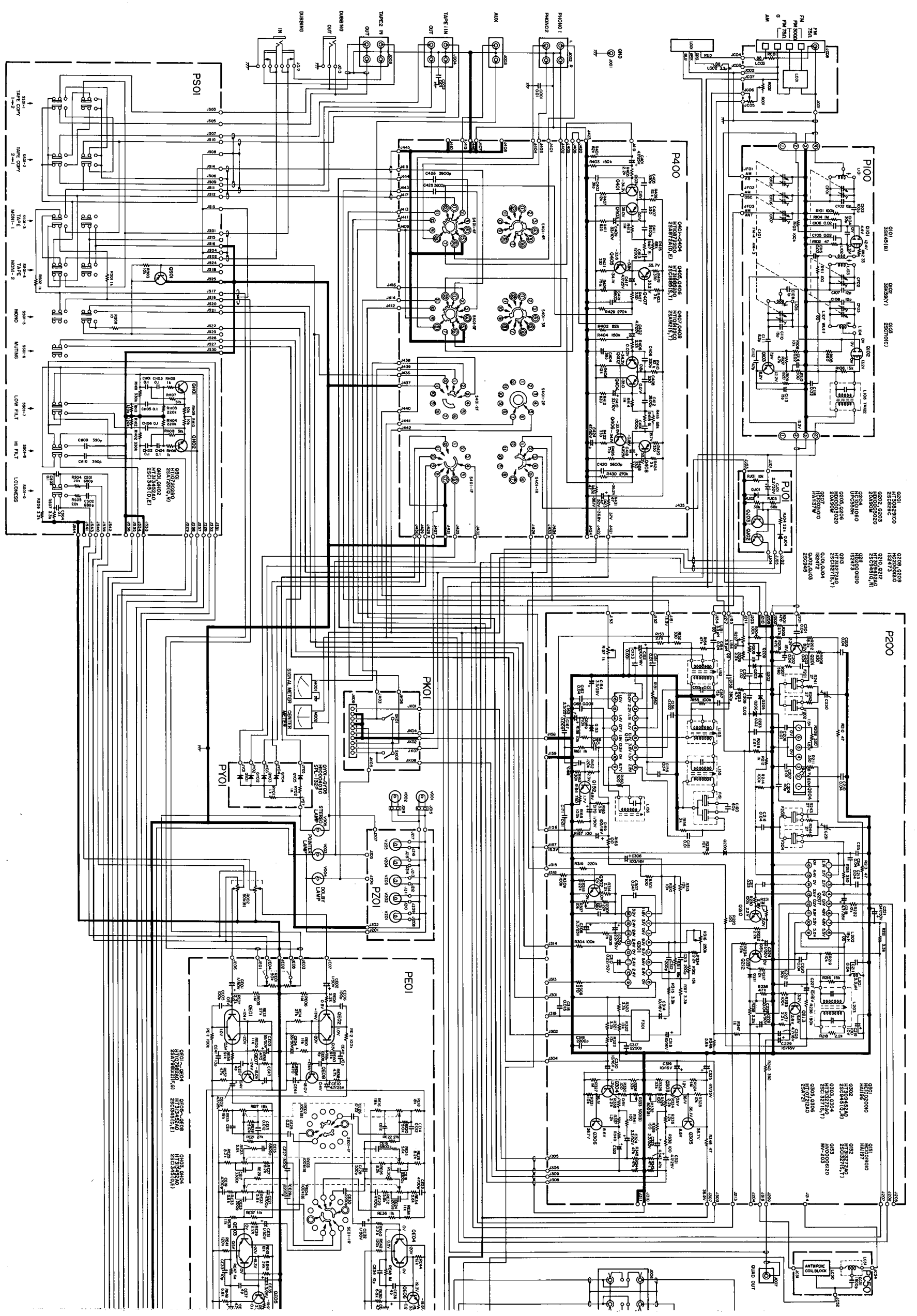

MODEL 2265B

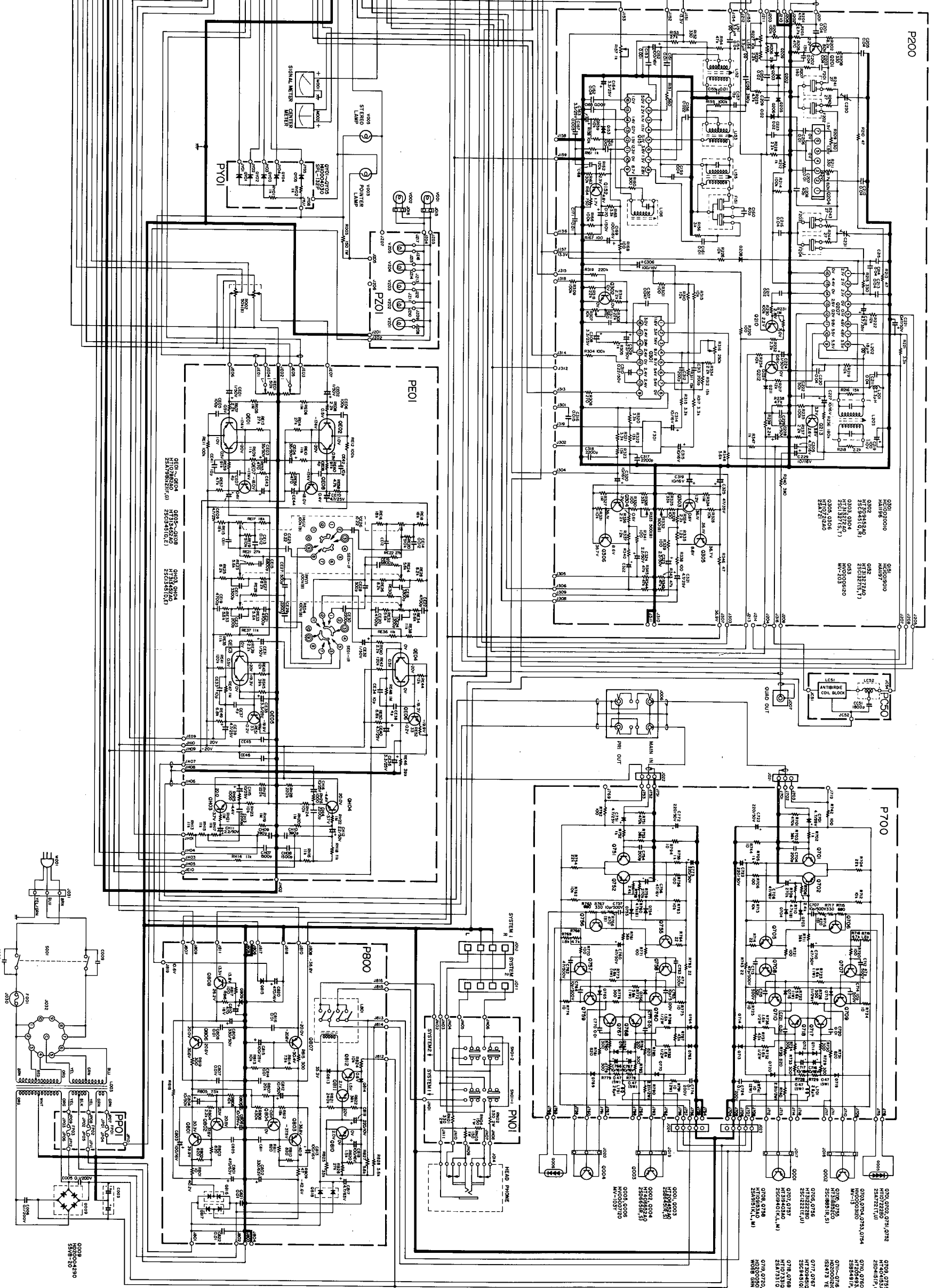

SCHEMATIC DIAGRAM—EUROPE

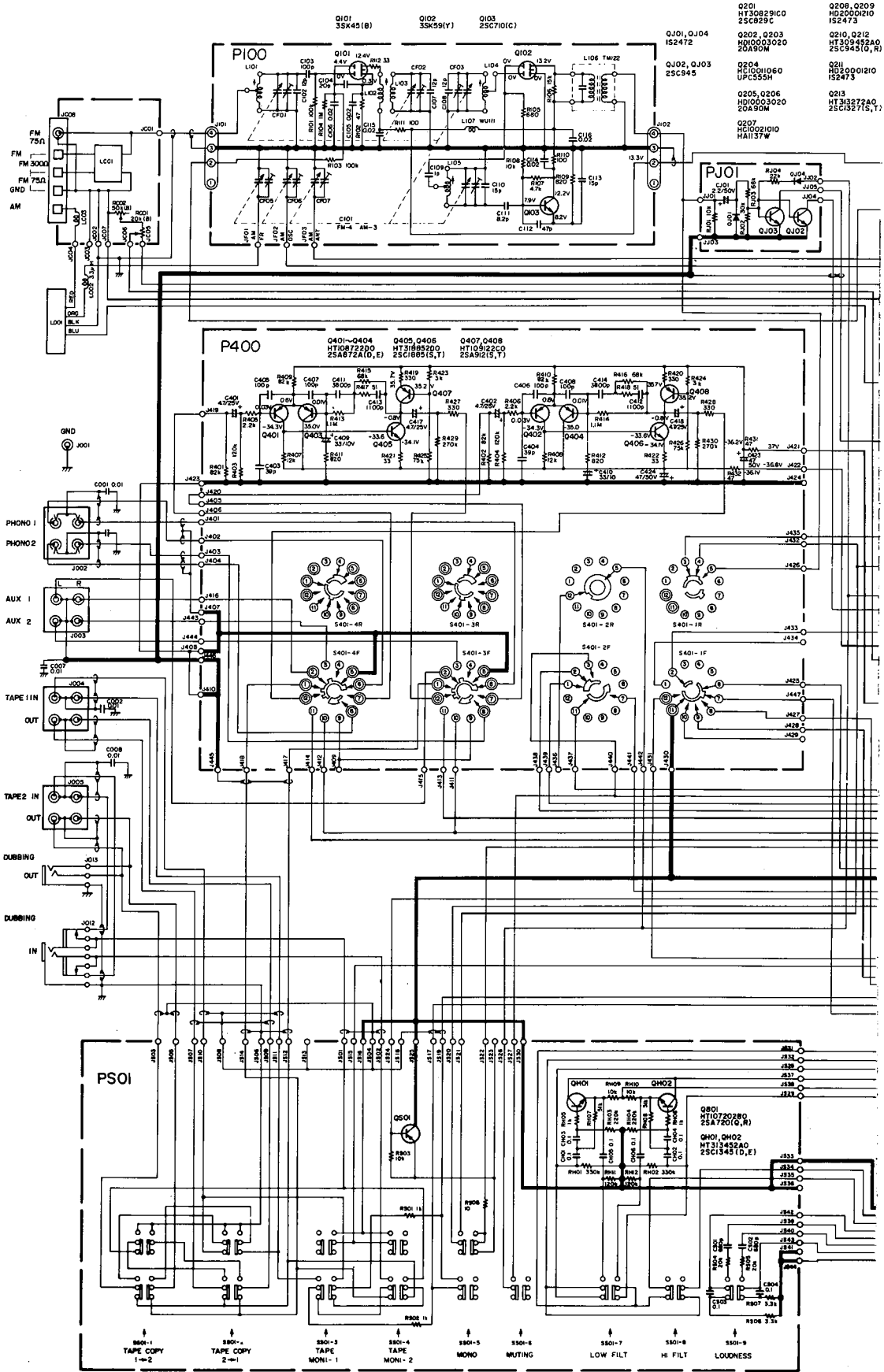

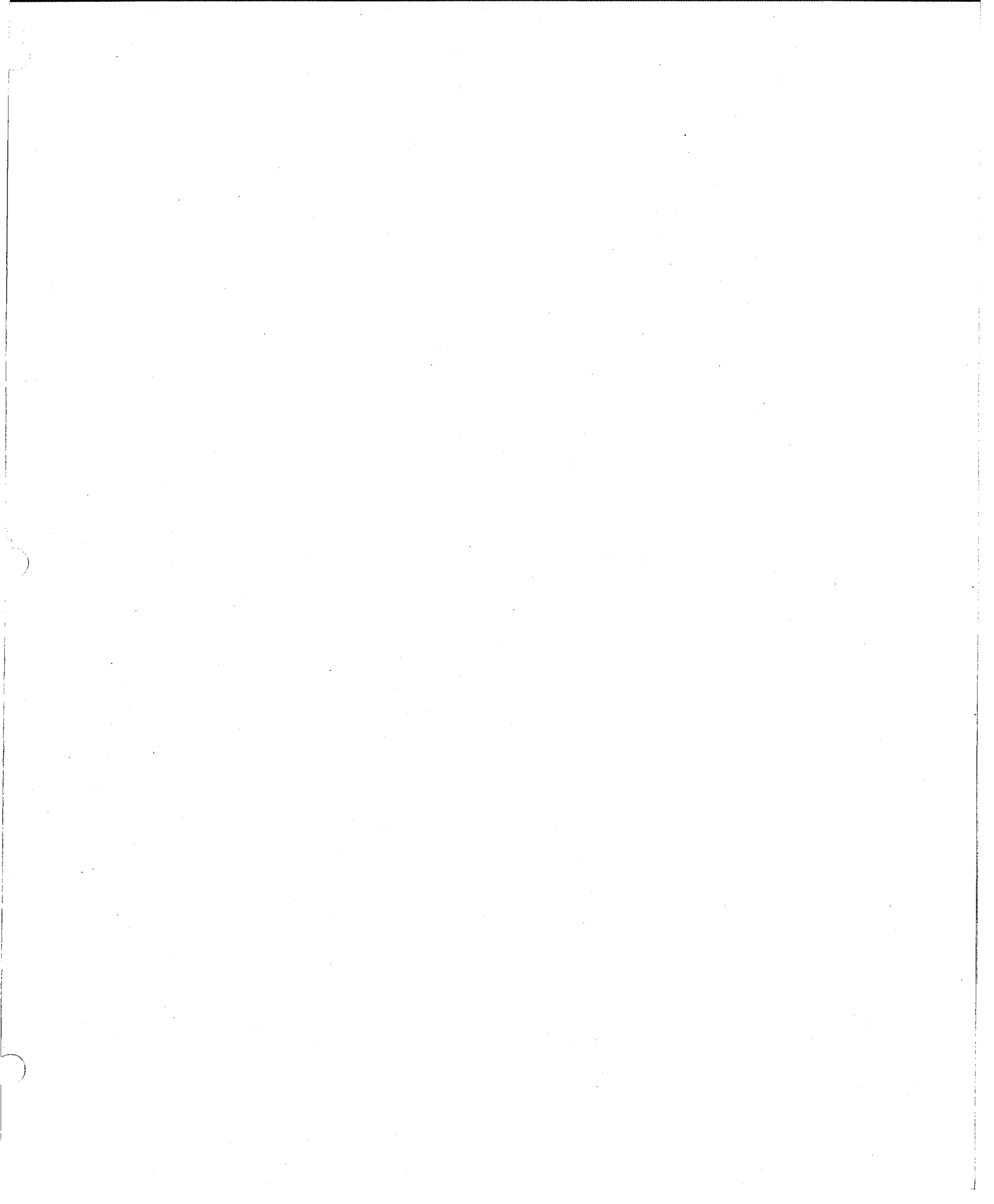



marantz

MARANTZ CO., INC. · P.O. BOX 577 · CHATSWORTH, CALIFORNIA · 91311



A WHOLLY-OWNED SUBSIDIARY OF SUPERSCOPE INC., CHATSWORTH, CALIFORNIA · 91311

DOLBY is a trademark of Dolby Laboratories, Inc.