

2330

56

SERVICE MANUAL 4001

marantz

model 2330

Stereophonic Receiver

TABLE OF CONTENTS

Section	Title	Page
1.	P.W. BOARDS	1
2.	TEST EQUIPMENT REQUIRED FOR SERVICING	1
3.	AM ALIGNMENT PROCEDURES	2
3.1	AM IF Alignment	2
3.2	AM Frequency Range and Tracking Alignment	2
3.3	AM Signal Strength Meter Alignment	2
4.	FM ALIGNMENT PROCEDURES	2
4.1	FM Frequency Range and Tracking Alignment	2
4.2	Stereo Separation Alignment	2
4.3	Muting Circuit Alignment	2
5.	DOLBY FM DECODER CIRCUIT ALIGNMENT	2
6.	AUDIO ADJUSTMENT	3
6.1	Automatic Voltage Regulator Adjustment	3
6.2	Main Amplifier DC Off-set Alignment	3
6.3	Idle-current Adjustment	3
6.4	Main Amplifier DC Off-set Re-alignment	3
6.5	Phono Amplifier Adjustment	3
7.	VOLTAGE CONVERSION FOR EUROPEAN MODEL	3
8.	DIAGRAMS	4
8.1	Connection Diagram - U.S.A. & CANADA	4
8.2	Connection Diagram - EUROPE	6
8.3	Block Diagram - U.S.A. & CANADA	8
8.4	Block Diagram - EUROPE	10
9.	SCHEMATIC DIAGRAMS AND COMPONENT LOCATIONS	12
9.1	FM Front End Circuit Board P100	12
9.2	AM Tuner Circuit Board P150	13
9.3	FM IF Amplifier Circuit Board P200	14
9.4	MPX Stereo Decoding Amplifier Circuit Board P300	16
9.5	Phono Amplifier Circuit Board P400	17
9.6	Dolby FM Decoder Circuit Board P600 - U.S.A. & CANADA	18
9.7	Main Amplifier Circuit Board P700	19
9.8	Power Supply and Protection Relay Circuit Board P800	20
9.9	Pre and Tone Amplifier Circuit Board PE01	21
9.10	Buffer Amplifier Circuit Board PH01	22
9.11	Function Lamp Circuit Board PY01	23
9.12	Dial Lamp Circuit Board PZ01	23
9.13	Hi/Low Filters, Loudness and Speaker Switches Circuit Board PU01	24
9.14	Tape Copy, MPX Noise Filter, Multipath and FM Muting Switches Circuit Board PT01	25
9.15	FM Balun and Muting Level Circuit Board PC01	25

10. MAJOR COMPONENT LOCATIONS	26
10.1 Cabinet - Front View - U.S.A. & CANADA	26
10.2 Chassis - Top View - U.S.A. & CANADA	26
10.3 Cabinet - Rear View - U.S.A. & CANADA	27
10.4 Chassis - Bottom View - U.S.A.	27
10.5 Cabinet - Front View - EUROPE	28
10.6 Chassis - Top View - EUROPE	28
10.7 Cabinet - Rear View - EUROPE	29
10.8 Chassis - Bottom View - EUROPE	29
11. EXPLODED VIEWS	30
11.1 Mechanical Exploded View	30
11.2 Packing Material Exploded View	32
12. PARTS LIST	34
13. TECHNICAL SPECIFICATIONS	48
14. SCHEMATIC DIAGRAMS	50,51

INTRODUCTION

This service manual was prepared for use by Authorized Warranty Stations and contains service information for the Marantz Model 2330 Stereophonic Receiver.

Servicing information and voltage data included in this manual are intended for use by the knowledgeable and experienced technician only. All instructions should be read carefully. No attempt should be made to proceed without a good understanding of the operation of the receiver.

The parts list furnishes information by which replacement part may be ordered from the Marantz Company. A simple description is included for parts which can be usually obtained through local suppliers.

1. P.W. BOARDS

As can be seen from the circuit diagram, the chassis of the Model 2330 consists of the following units. Each unit mounted on a printed circuit board is drawn within bold dotted-line block on the circuit diagram.

1. FM Front End Mounted on P.W. Board P100
2. AM Tuner Mounted on P.W. Board P150

3. FM IF Amplifier Mounted on P.W. Board P200
4. MPX Stereo Decoding Amplifier
. Mounted on P.W. Board P300
5. Phono Amplifier Mounted on P.W. Board P400
6. Dolby FM Decoder Mounted on P.W. Board P600
7. Main Amplifier Mounted on P.W. Board P700
8. Power Supply and Protection Relay Circuit
. Mounted on P.W. Board P800
9. Pre and Tone Amplifier. Mounted on P.W. Board PE01
10. Buffer Amplifier Mounted on P.W. Board PH01
11. Function Lamp Mounted on P.W. Board PY01
12. Dial Lamp Mounted on P.W. Board PZ01
13. Hi/Low Filters, Loudness and Speaker Switches
. Mounted on P.W. Board PU01
14. Tape Copy, MPX Noise Filter, Multipath and
FM Muting Switches . . Mounted on P.W. Board PT01
15. FM Balun and Muting Level
. Mounted on P.W. Board PC01
16. Fuse Mounted on P.W. Board PR01

2. TEST EQUIPMENT REQUIRED FOR SERVICING

Table 1 lists the test equipment required for servicing the Model 2330 Stereophonic Receiver.

Item	Manufacturer and Model No.	Use
AM Signal Generator		Signal source for AM alignment
Test Loop		Use with AM Signal Generator
FM Signal Generator MPX Signal Generator	Sound Technology Model 1000A	Signal source for FM alignment Stereo separation alignment and trouble shooting
Distortion Analyzer Audio Oscillator AC VTVM	Sound Technology Model 1700A	Distortion measurements Sinewave and squarewave signal source Voltage measurements (AC)
Oscilloscope	Tektronix Model T932 Philips Model 3232	Waveform analysis and trouble shooting and ASO alignment
Frequency Counter	Fluke Model 1900A	MPX Oscillator adjustment (VCO)
Circuit Tester		Trouble shooting
DC VTVM	Fluke Model 8000 "Digital" Simpson Model 313, Triplet Model 801	Voltage measurements (DC)
AC Wattmeter	Simpson Model 1379	Monitors primary power to amplifier
AC Ammeter	Commercial Grade (1-10A)	Monitors amplifier output under short circuit condition
Line Voltmeter	Simpson Model 1359	Monitors potential of primary power to amplifier
Variable Autotransformer	Superior Electronic Co., Powerstat Model 116B-10A	Adjusts level of primary power to amplifier
Shorting Plug	Use phono plug with 600-ohm across center pin and shell	Shorts amplifier input to eliminate noise pickup
Output Load (8 ohms, 0.5%, 100W)	Commercial Grade	Provides 8-ohm load for amplifier output termination
Output Load (4 ohms, 0.5%, 100W)	Commercial Grade	Provides 4-ohm load for amplifier output termination

Table 1. Test Equipment Required for Servicing

3. AM ALIGNMENT PROCEDURES

3.1 AM IF ALIGNMENT

1. Connect a sweep generator to the J153 and an alignment scope to R167.
2. Rotate each core of IF transformer L153 for maximum height and flat top symmetrical response.

3.2 AM FREQUENCY RANGE AND TRACKING ALIGNMENT

1. Set AM signal generator to 515 kHz. Turn the tuning capacitor fully closed (place the tuning pointer at the low end) and adjust the oscillator coil L152 for maximum audio output.
2. Set the signal generator to 1650 kHz. Place the tuning pointer in the high frequency end and adjust the oscillator trimmer on the oscillator tuning capacitor for maximum audio output.
3. Repeat steps 1 and 2 above until no further adjustment is necessary.
4. Set the generator to 600 kHz and tune the receiver to the same frequency and adjust a slug core of AM ferrite-rod antenna L001 and RF coil L151 for maximum output.
5. Set the generator to 1400 kHz and tune the receiver to the same frequency and adjust both trimming capacitors of antenna and RF tuned circuit for maximum output.
6. Repeat steps 4 and 5 until no further adjustment is necessary.

NOTE: During tracking alignment reduce the signal generator output as necessary to avoid AGC action.

3.3 AM SIGNAL STRENGTH METER ALIGNMENT

Set an AM signal generator to 1000 kHz at $5\text{ k}\mu\text{V}$, and adjust R178 so that the signal strength meter may read 90% of the full scale.

4. FM ALIGNMENT PROCEDURES

4.1 FM FREQUENCY RANGE AND TRACKING ALIGNMENT

1. Connect an FM signal generator to the FM ANTENNA terminals and an oscilloscope and an audio distortion analyzer to the TAPE MONITOR OUT jacks on the rear panel.
2. Set the signal generator to 87.4 MHz and provide about 3 to $5\text{ }\mu\text{V}$. Place the tuning pointer at the low frequency end by rotating the tuning knob and adjust the core of oscillator coil L105 to obtain maximum audio output.
3. Set the signal generator to 109 MHz and provide about 3 to $5\text{ }\mu\text{V}$ output. Rotate the tuning knob and place the tuning pointer at the high frequency end and adjust the trimming capacitor CF04 for maximum output.
4. Repeat steps 2 and 3 above until no further adjustment is necessary.
5. Set the signal generator to 90 MHz and tune the receiver to the same frequency. Decrease signal generator output until the audio output level decreases with the decreasing generator output. Adjust the antenna coil L101, RF coils L102, L103 and L104 and IF transformer L106 for minimum audio distortion.

6. Set the signal generator to 106 MHz and tune the receiver to the same frequency. Adjust the trimming capacitor CF01, CF02 and CF03 for minimum distortion.
7. Repeat steps 5 and 6 above until no further adjustment is necessary.
8. Adjust the secondary core (upper) of discriminator transformer L201 until the center tuning meter pointer indicates its center with no signal applied. Set the FM signal generator to 98 MHz and increase its output level to $1\text{ k}\mu\text{V}$ and tune the receiver to the same frequency so that the center tuning meter pointer indicates its center. Adjust the primary core (lower) of L201 for minimum distortion.
9. Set the signal generator to 98 MHz at $100\text{ k}\mu\text{V}$, and adjust R374 so that the signal strength meter may read 90% of the full scale.

4.2 STEREO SEPARATION ALIGNMENT

1. Set the FM signal generator to provide $1\text{ k}\mu\text{V}$ at 98 MHz. Tune the receiver to the same frequency so that the center tuning meter pointer indicates its center.
2. Turn the signal generator modulation off (with the pilot signal turned off), connect a frequency counter to test point J310, and adjust R311 until the frequency counter may precisely read 19 kHz.
3. Modulate the signal generator with stereo composite signal consisting only of subchannel signal (of course, a pilot signal must be included).
4. Adjust the trimming resistor R301 for maximum and same separation in both channels.

4.3 MUTING CIRCUIT ALIGNMENT

1. Connect a VTVM across the resistor R363 and adjust the it until the meter reads 0.75 V DC at no signal.
2. Set the FM signal generator to provide $1\text{ k}\mu\text{V}$ at 98 MHz and tune the receiver to the same frequency correctly.
3. Depress the FM MUTING pushswitch. Shift the signal generator frequency to higher and lower and note both higher and lower shifted frequencies at which undesirable audio side responses are muted out. Adjust the R363 so that the same shifted frequencies mute the undesirable side response.
4. Adjust R362 for proper frequency shift at which the muting circuit operates.

5. DOLBY FM DECODER CIRCUIT ALIGNMENT

The left and right channels each has a Dolby FM decoder circuit which runs in receiving an Dolby FM broadcast. When the SELECTOR switch is at the DOLBY FM position, the FM Tuner outputs come from J602 (L) and J605 (R) to the decoder circuit (Q601, Q602), the outputs of which are fed out of J601 (L) and J606 (R). The +B source is supplied to J603. For aligning, apply a 1 mV, 1 kHz-, 50%-modulated FM signal to the Model 2330 and adjust R603 (L) and R604 (R) until the levels at the TAPE MONITOR OUT jacks become 580 mV in the Dolby FM mode of operation

6. AUDIO ADJUSTMENT

6.1 AUTOMATIC VOLTAGE REGULATOR ADJUSTMENT

Connect a DC voltmeter between pin terminals J804 and J805, and adjust the trimming resistor R809 for 35V DC.

6.2 MAIN AMPLIFIER DC OFF-SET ALIGNMENT

Connect a DC voltmeter with 0.5 or 1 V range between the speaker terminals and adjust the trimming resistor R727 for "zero" DC output on the meter. Repeat the same procedure for the other channel.

NOTE: During this alignment no load should be connected to the speaker terminals.

6.3 IDLE-CURRENT ADJUSTMENT

Connect a VTVM between pin terminals J716 and J717 or J718. Next, rotate the trimming resistor R726 fully counterclockwise, then rotate it clockwise until the VTVM reads 13.5 mV DC (25 mA). Repeat the same procedure for the other channel.

NOTE: During this alignment no load should be connected to the speaker terminals.

6.4 MAIN AMPLIFIER DC OFF-SET RE-ALIGNMENT

Check DC off-set voltage aligned in the procedure 2 and if any DC output is observed on the DC voltmeter, adjust the R727 again for "zero" output.

6.5 PHONO AMPLIFIER ADJUSTMENT

Connect an oscilloscope to the TAPE MONITOR OUT jacks and an audio signal generator to the PHONO jacks.

Place the SELECTOR switch in the PHONO position. Increase 1 kHz audio signal level gradually until a slight clipping on top of the sine-wave is observed on the oscilloscope. Adjust the trimming resistor R408 for equal clipping level. For the other channel adjust R409.

7. VOLTAGE CONVERSION FOR EUROPEAN MODEL

The European version of the Model 2330 is equipped with a universal power transformer that may be adjusted to operate at 110 V, 120 V, 220 V, or 240 V AC at 50 to 60 Hz. To convert the unit to a different power source voltage, reposition conversion plug as shown in Figure 1.

CAUTION: DISCONNECT POWER SUPPLY CORD FROM AC OUTLET BEFORE CONVERTING VOLTAGE.

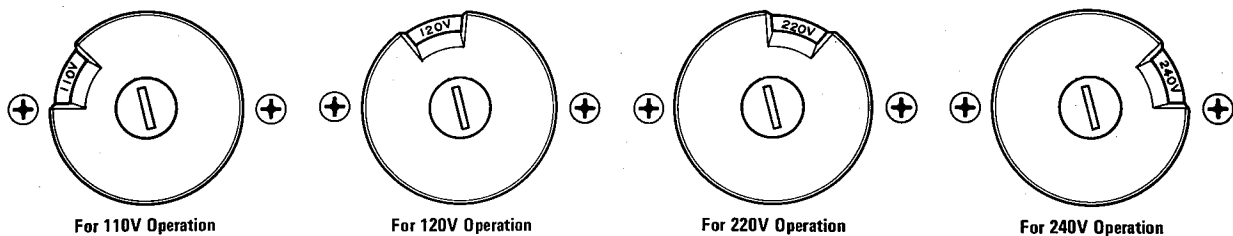
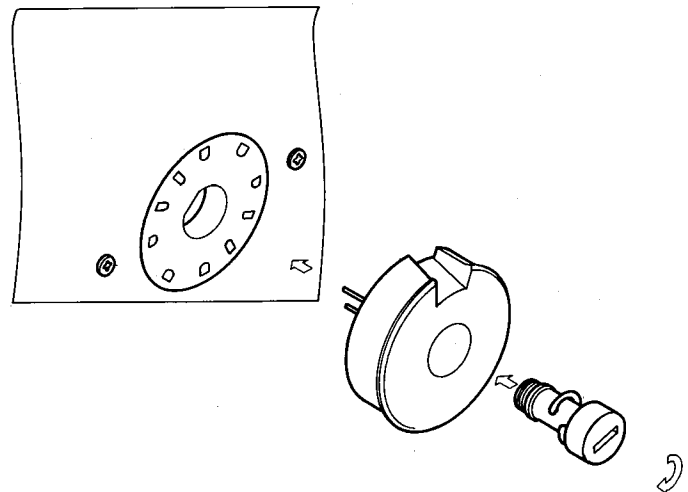

Figure 1. Voltage Conversion Chart

FTZ REGULATION

Instruction for the use in the range other than specified in FTZ codes.

Achtung für die Leute, die in dem Gebiet wohnen, wo die FTZ-Bestimmungen vorherrschend sind.

Sollte das Gerät auch für Frequenzen ausserhalb des in den FTZ-Bestimmungen angegebenen Bereiches empfangebereit sein, bitten wir, den Bereich durch Nachstellen des Kernes in der Oszillatortspule (in der Abbildung mit "FTZ" gekennzeichnet) so zu korrigieren, dass er den Bestimmungen entspricht.

8. DIAGRAMS

8.1 CONNECTION DIAGRAM - U.S.A. & CANADA

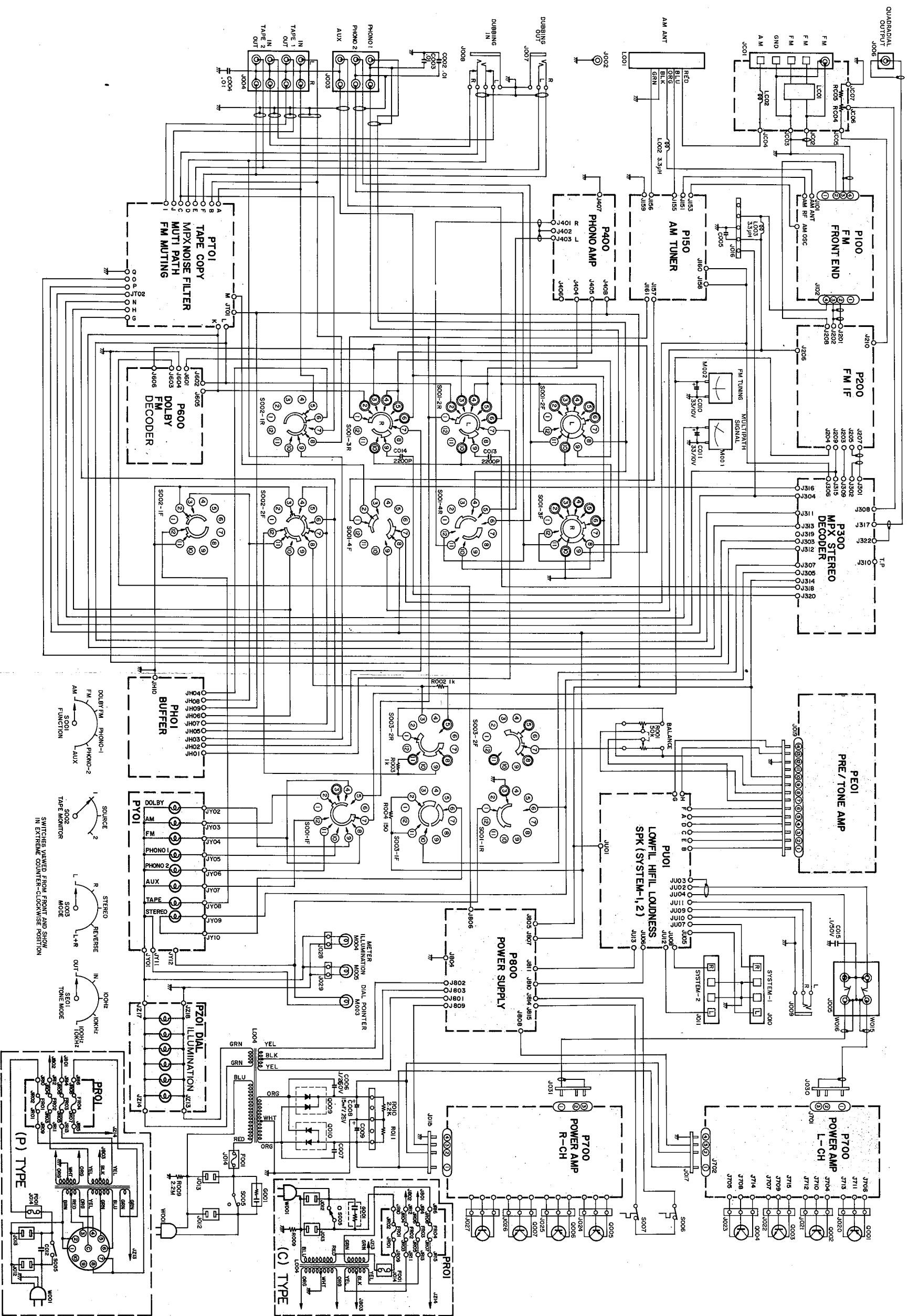

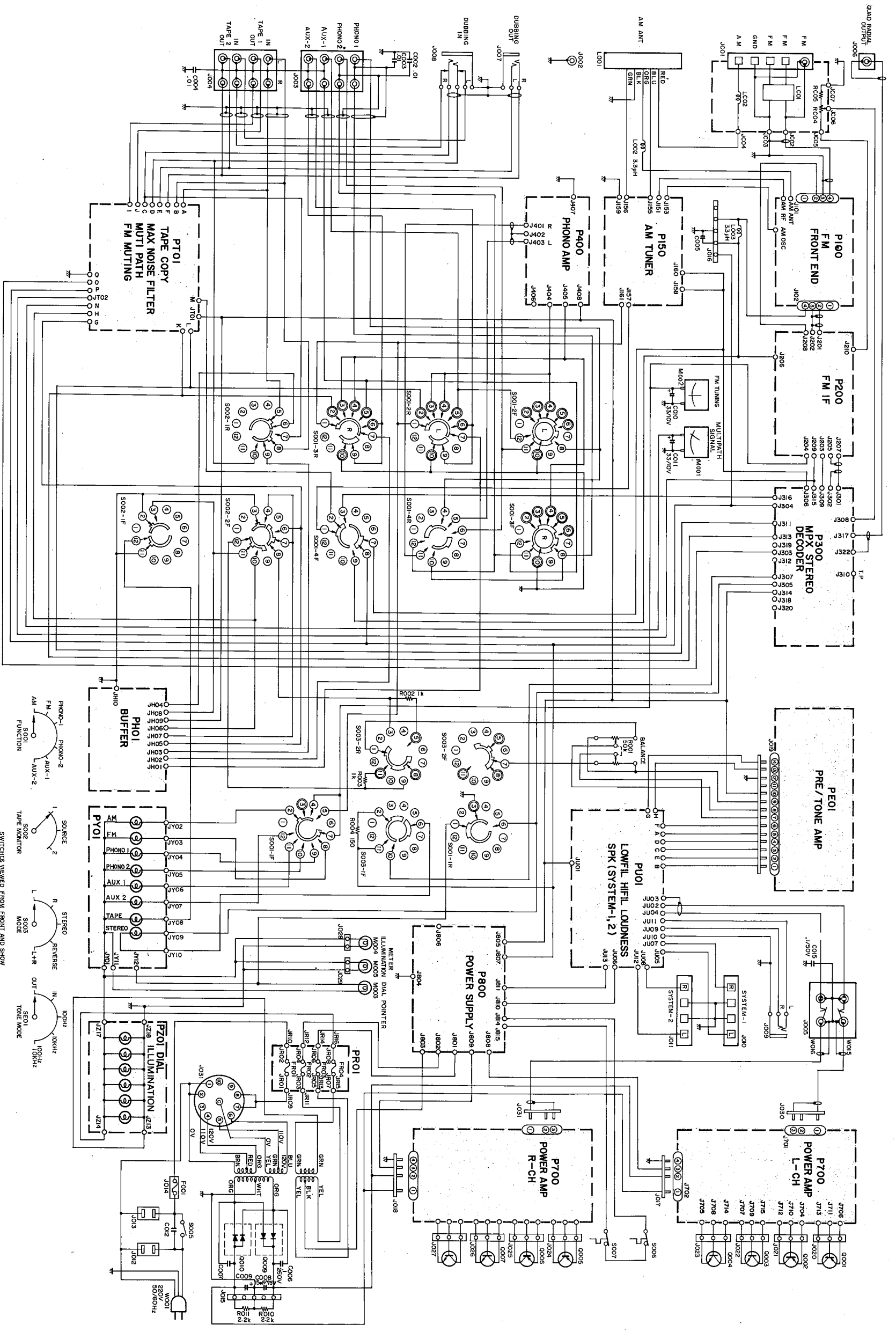

SWITCHES VIEWED FROM FRONT AND SHOWN IN EXTENSIVE SCHEMATIC-LOOKWISE POSITION

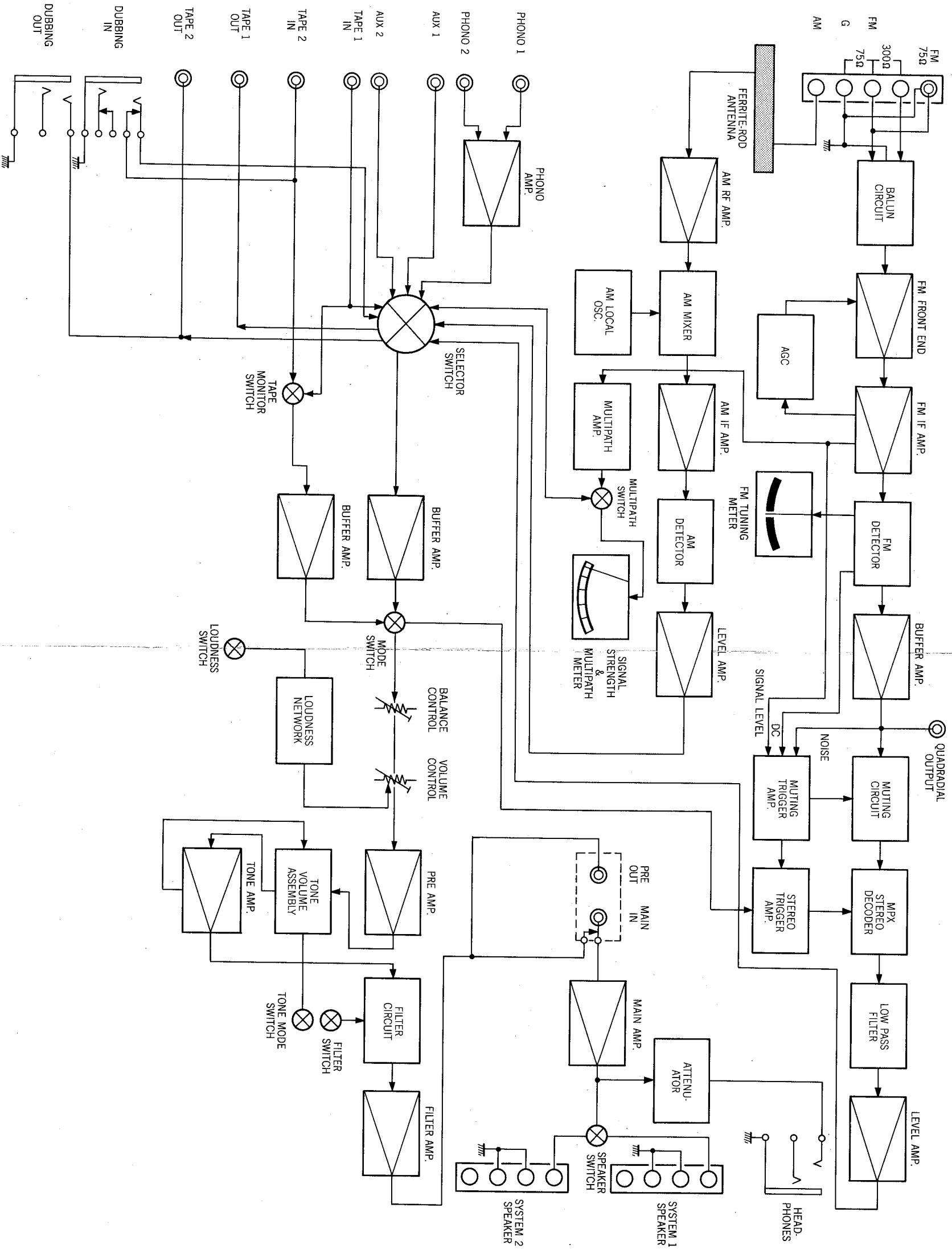

8.4 BLOCK DIAGRAM - EUROPE

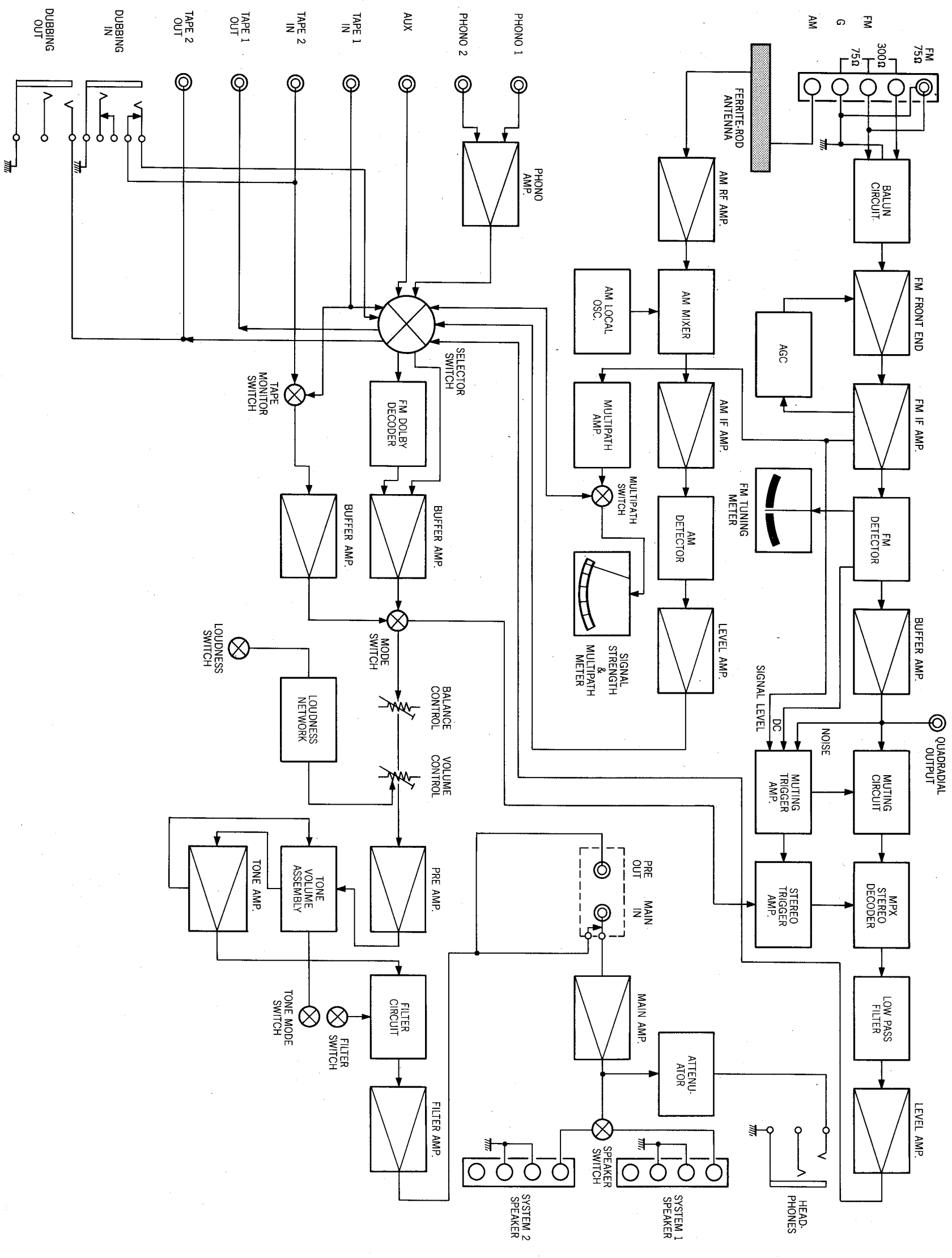

9. SCHEMATIC DIAGRAMS AND COMPONENT LOCATIONS

19.1 FM FRONT END CIRCUIT BOARD P100

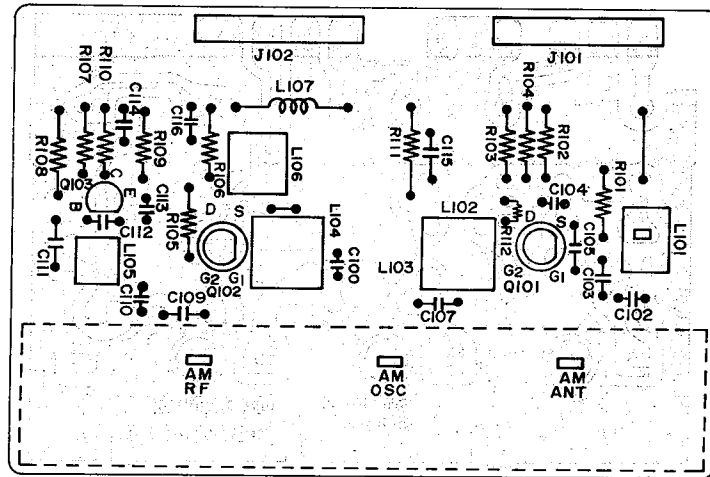
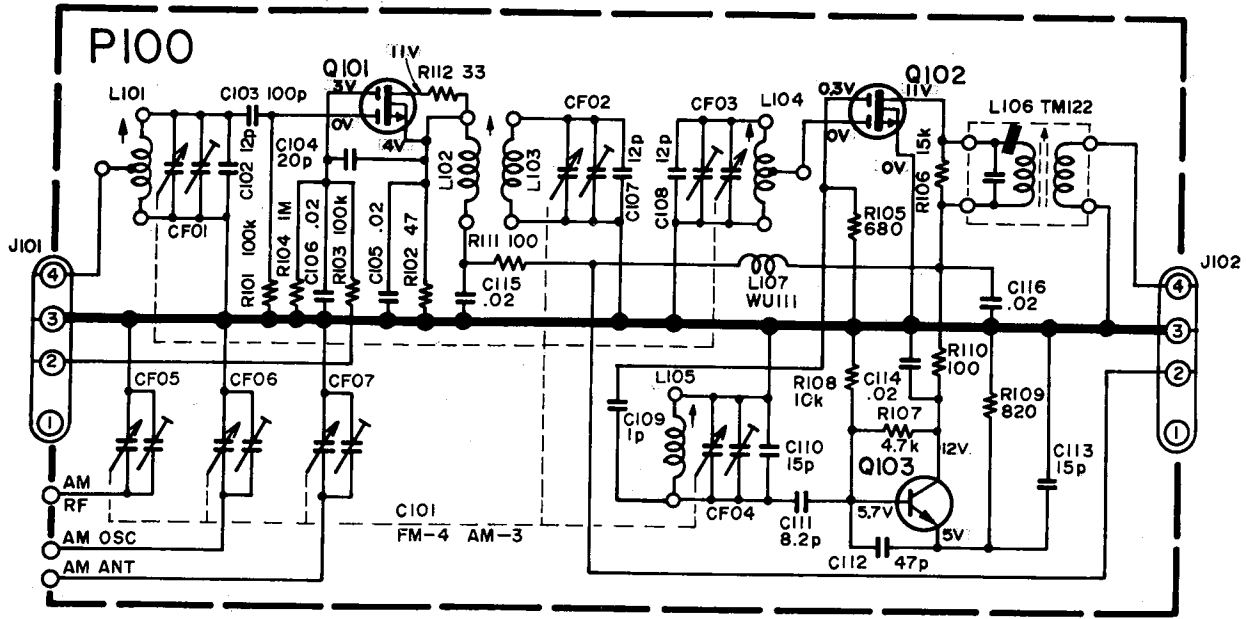

9.2 AM TUNER CIRCUIT BOARD P150

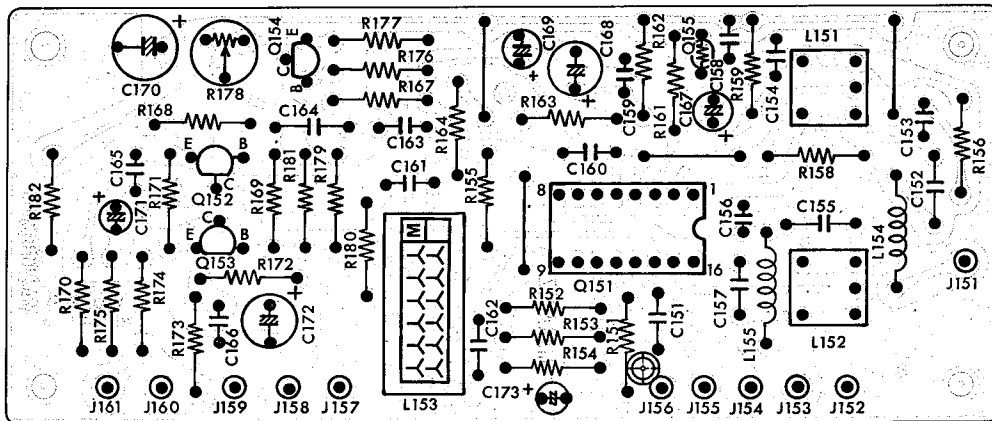
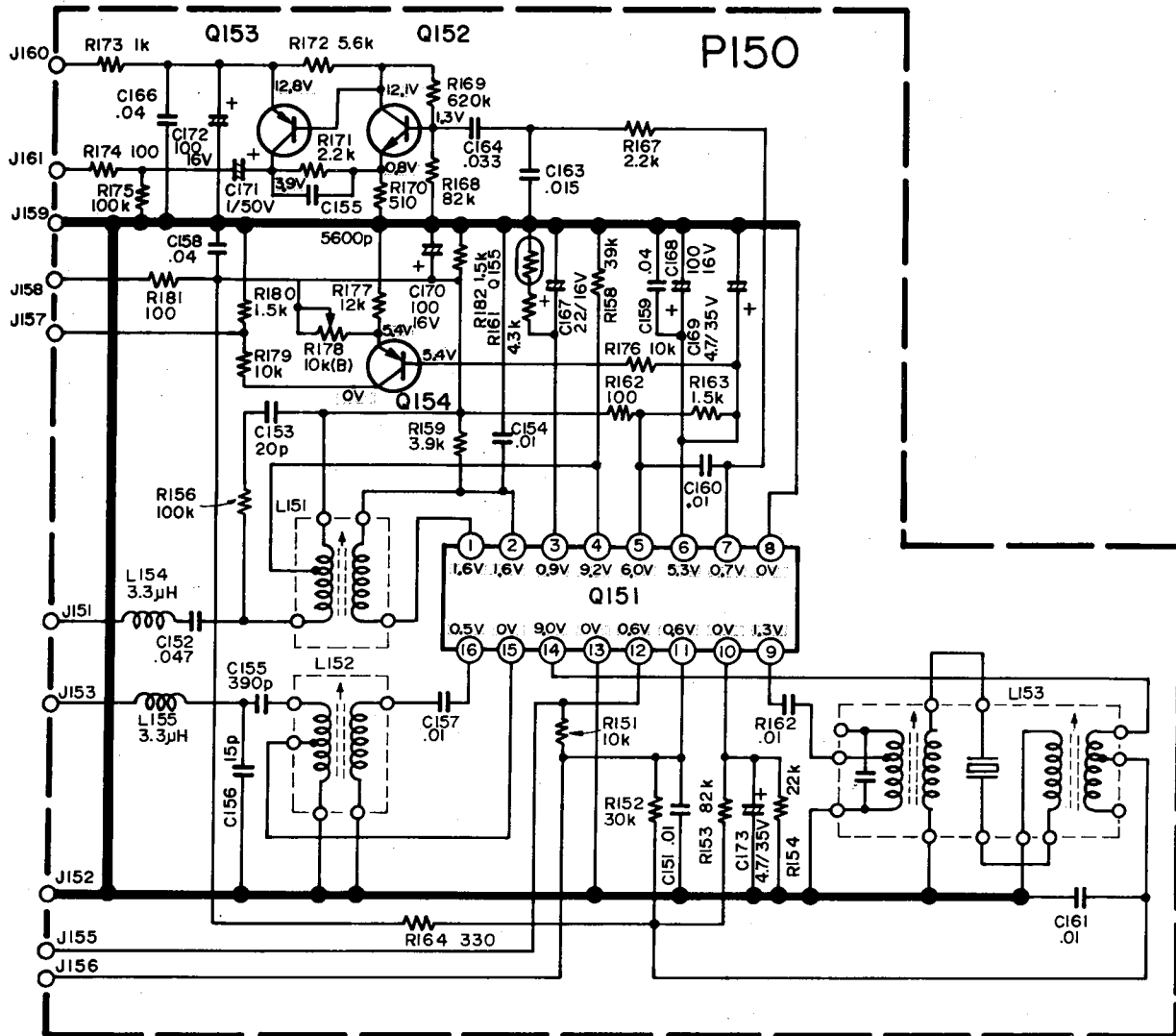

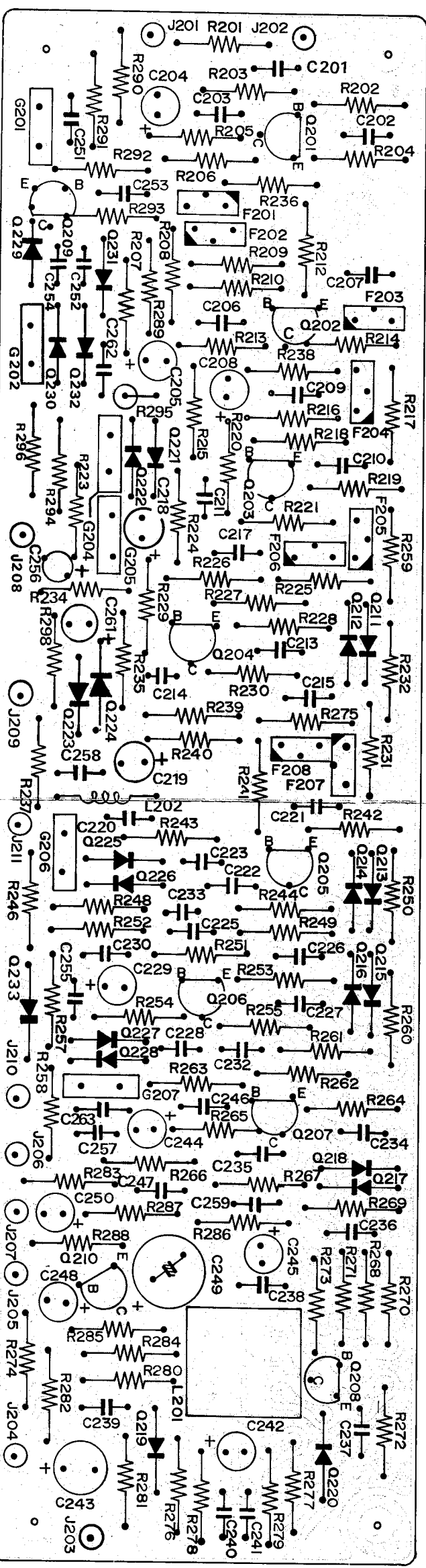
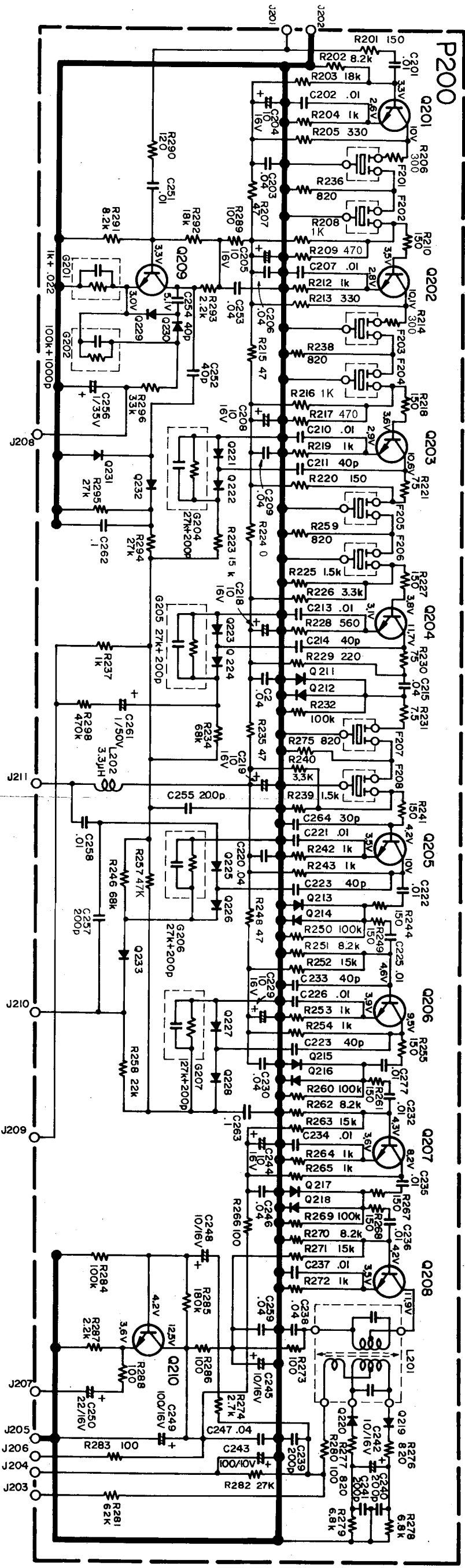

9.4 MPX STEREO DECODING AMPLIFIER CIRCUIT BOARD P300

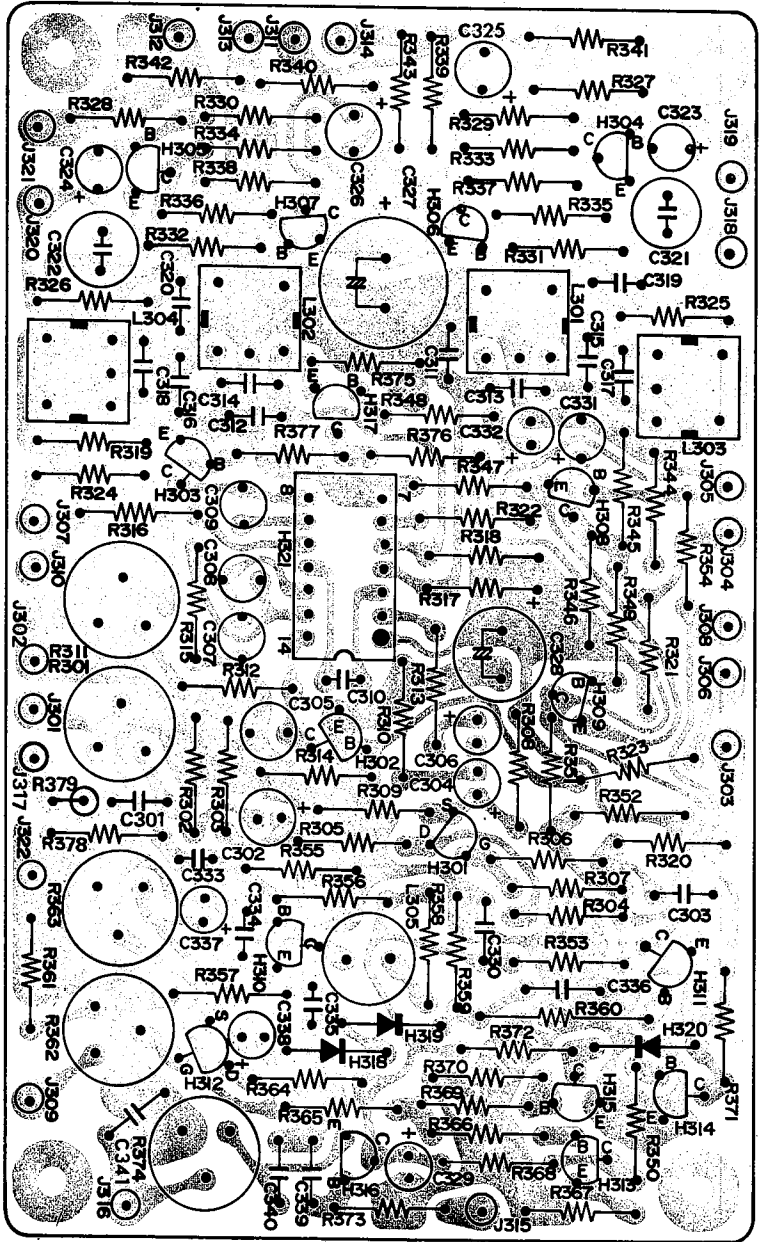
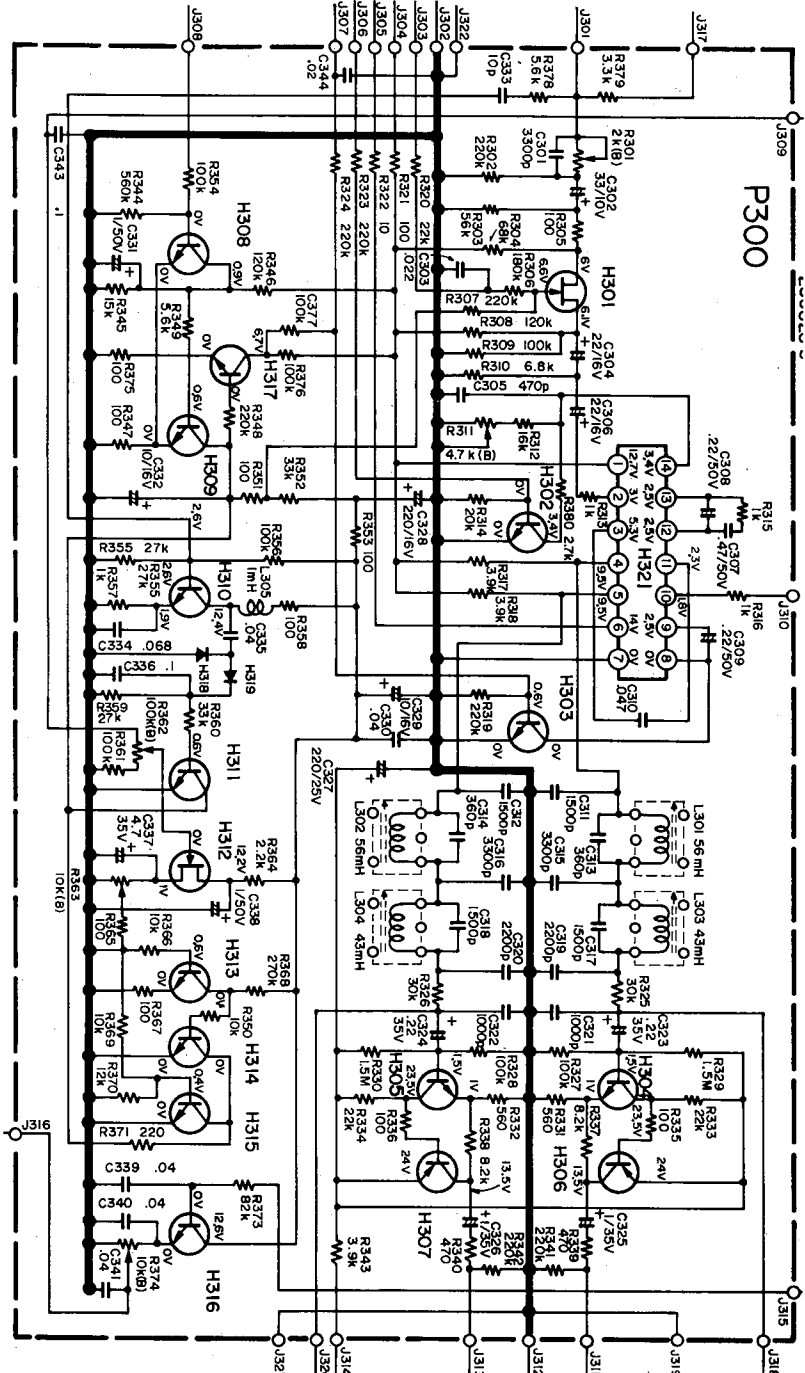

9.5 PHONO AMPLIFIER CIRCUIT BOARD P400

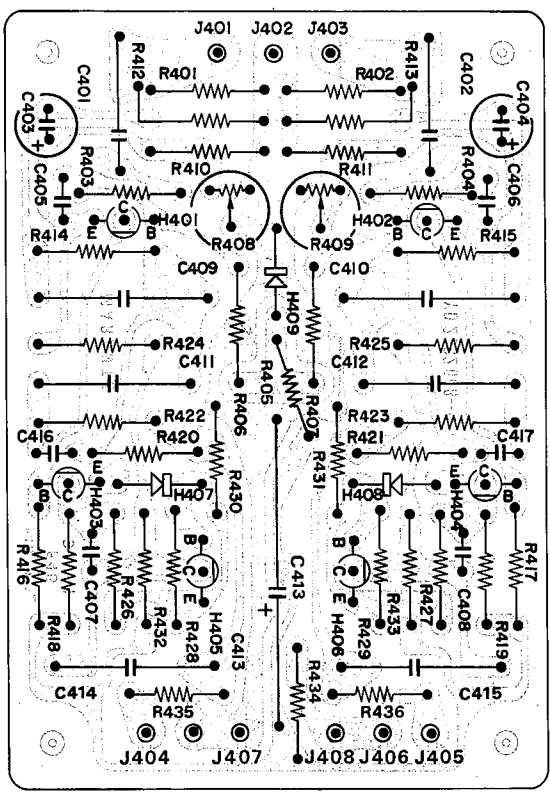
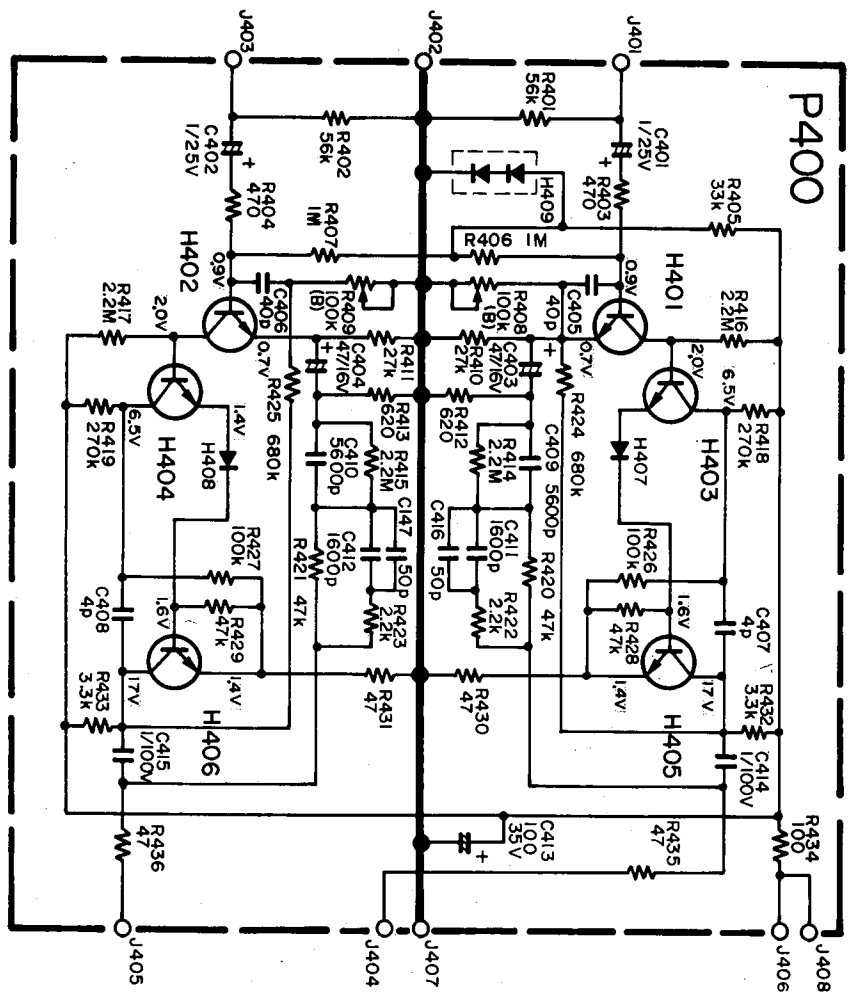

9.6 DOLBY FM DECODER CIRCUIT BOARD P600 - U.S.A. & CANADA

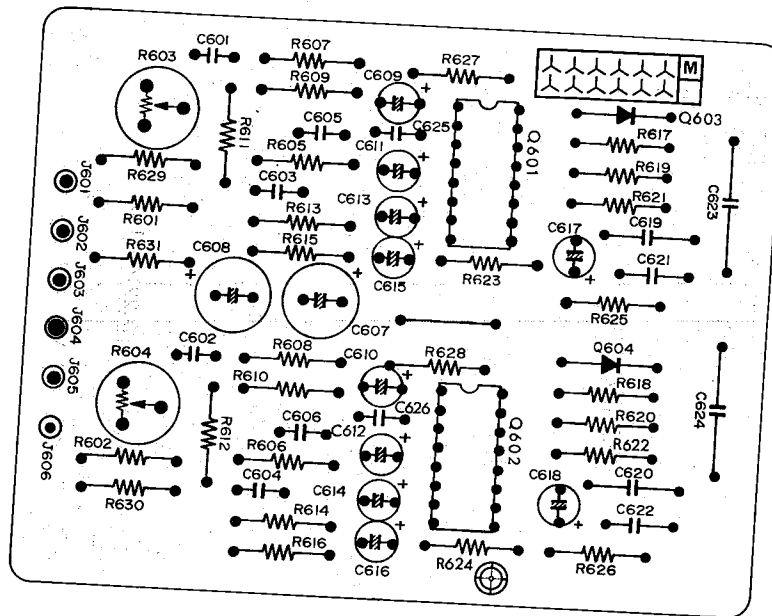
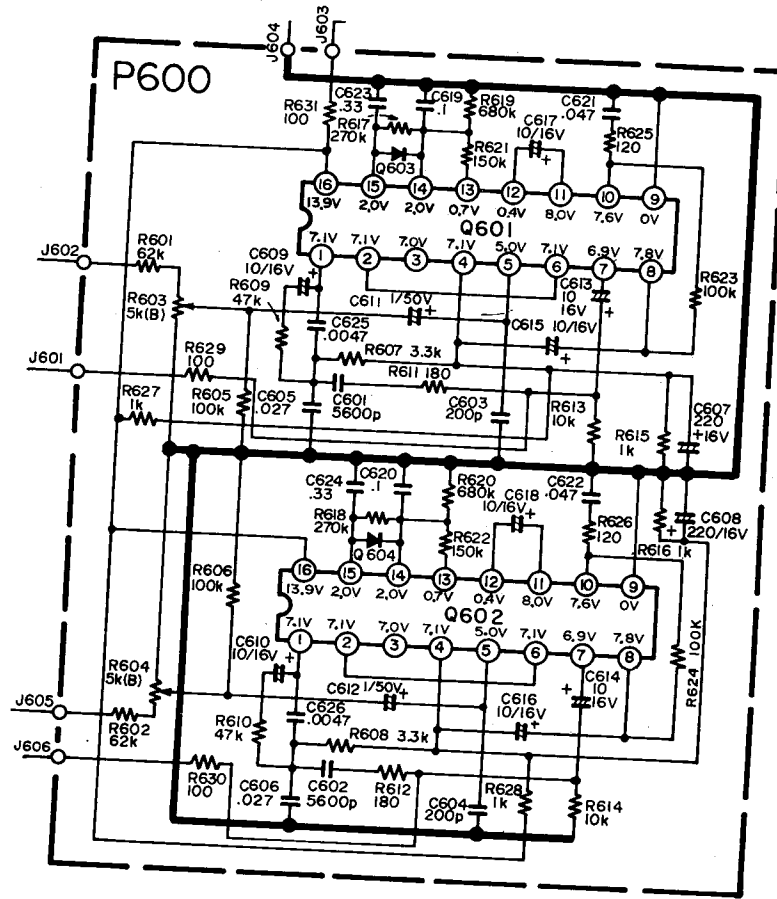

9.7 MAIN AMPLIFIER CIRCUIT BOARD P700

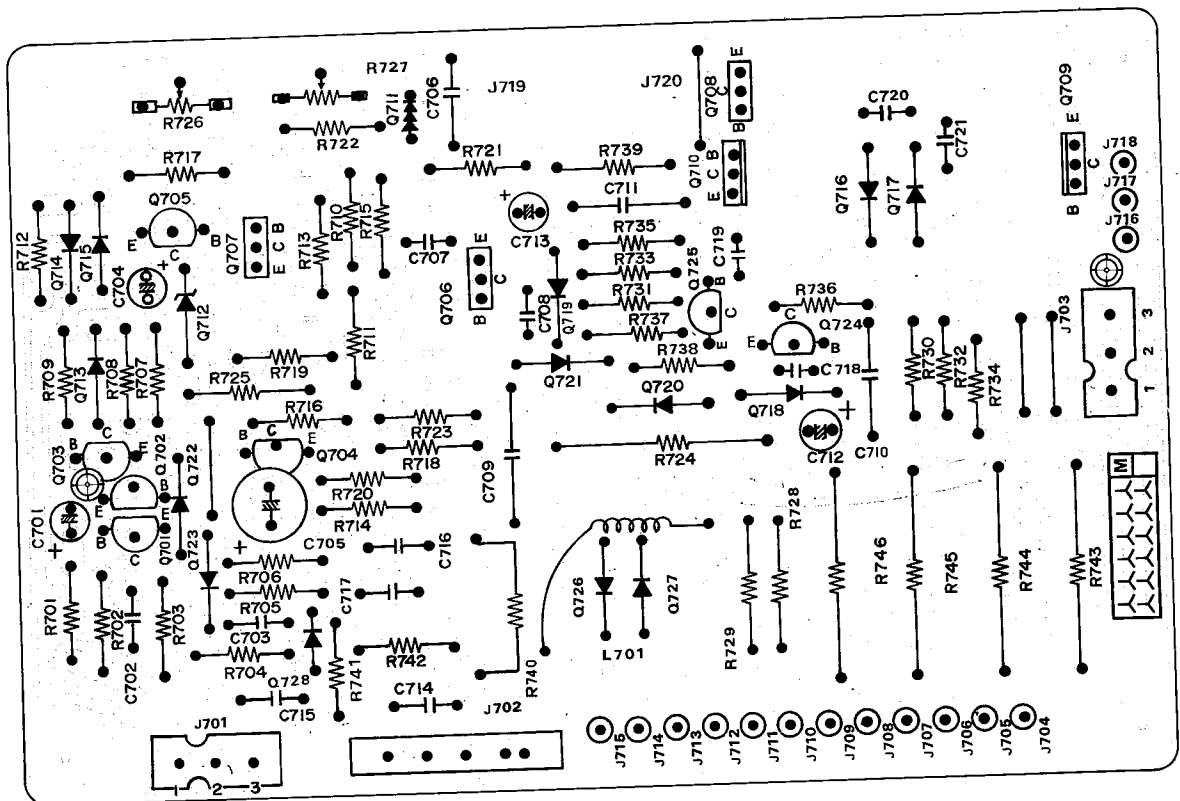
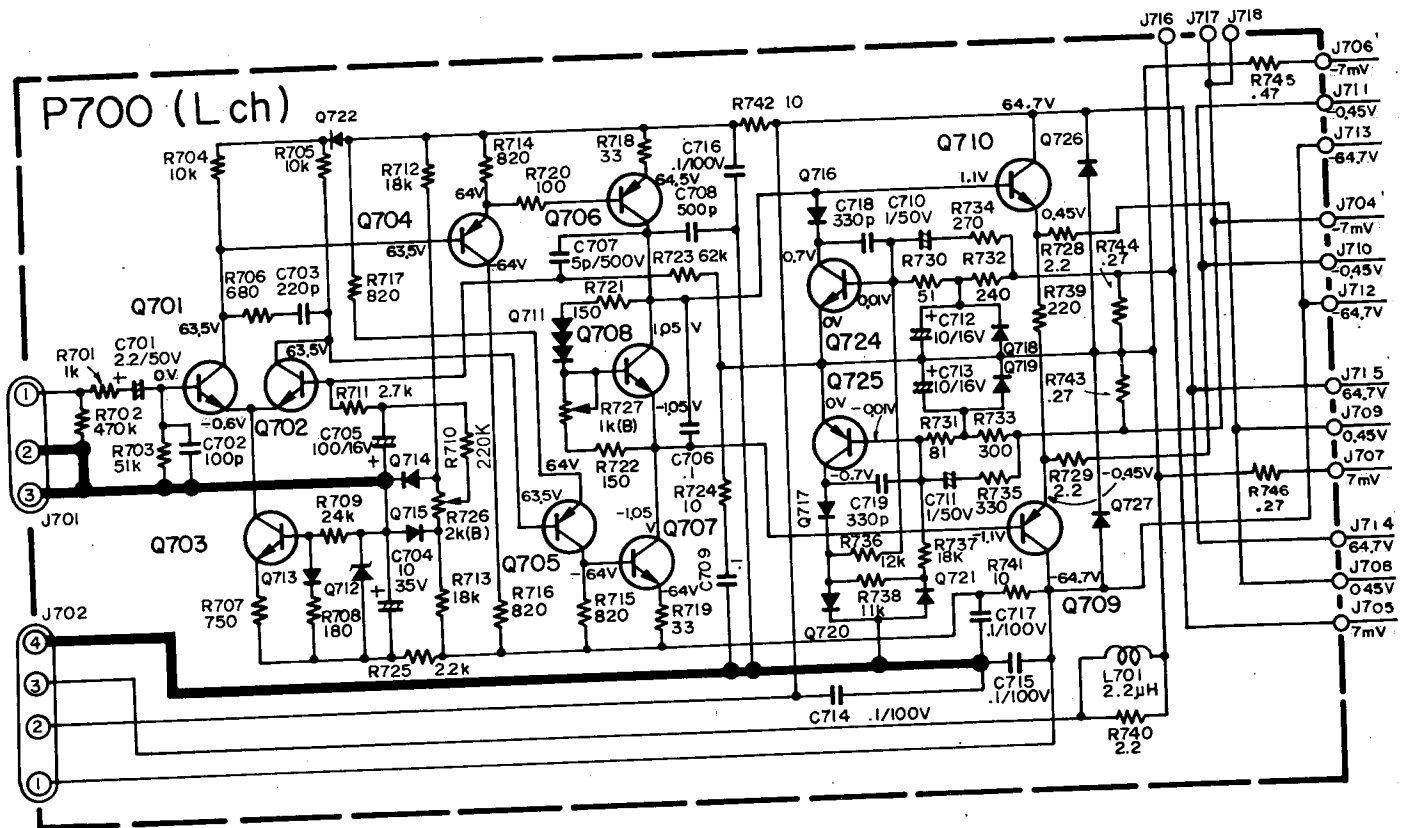

9.8 POWER SUPPLY AND PROTECTION RELAY CIRCUIT BOARD P800

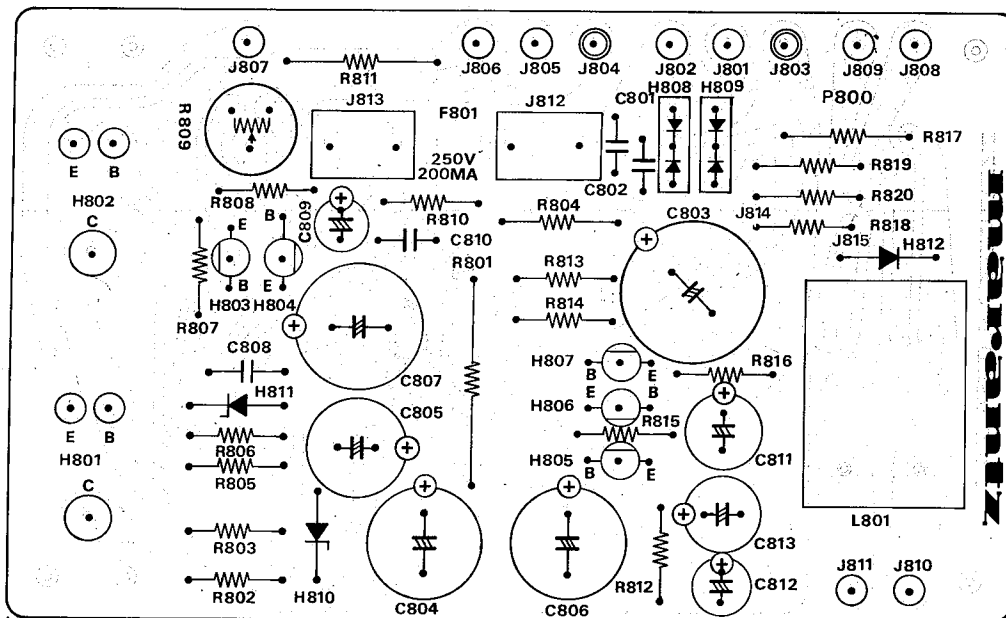
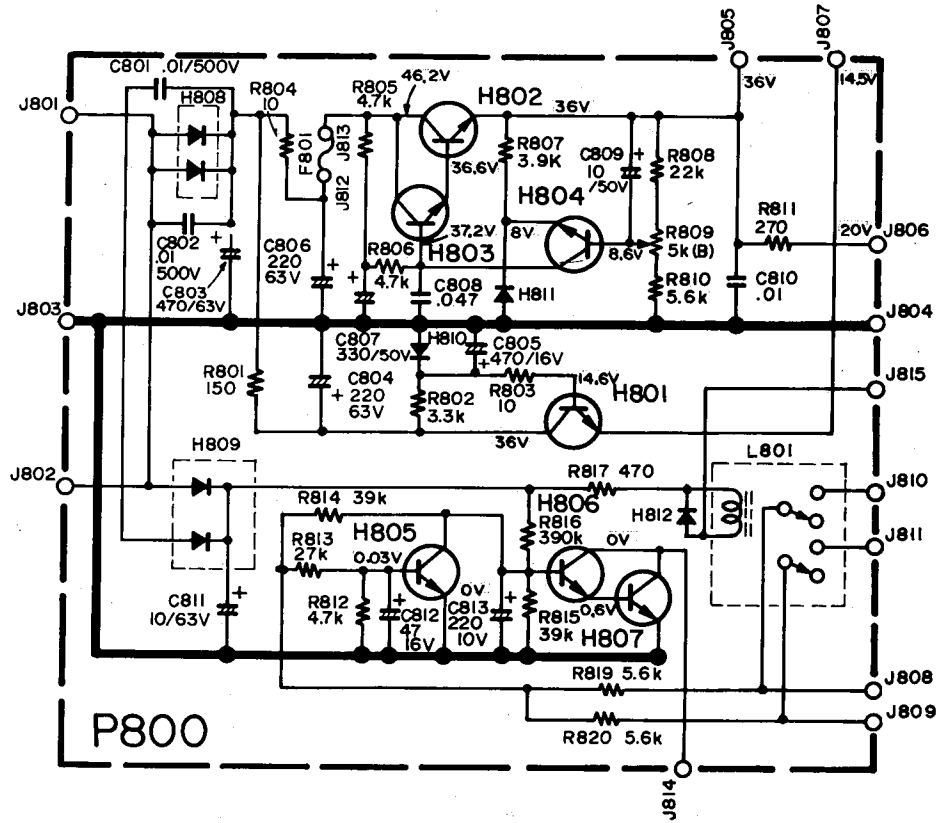

9.9 PRE AND TONE AMPLIFIER CIRCUIT BOARD PE01

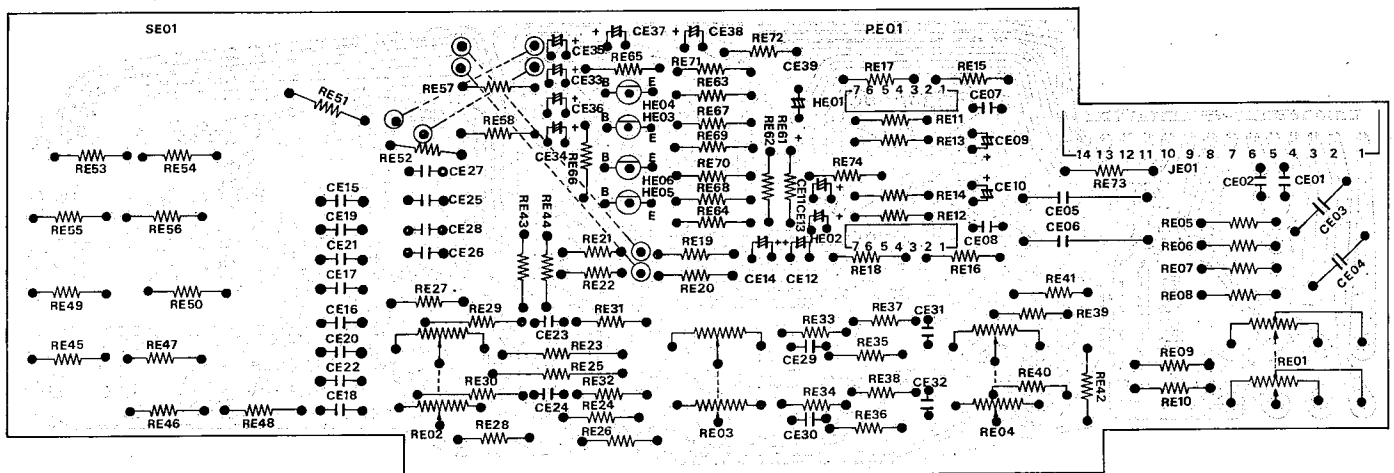
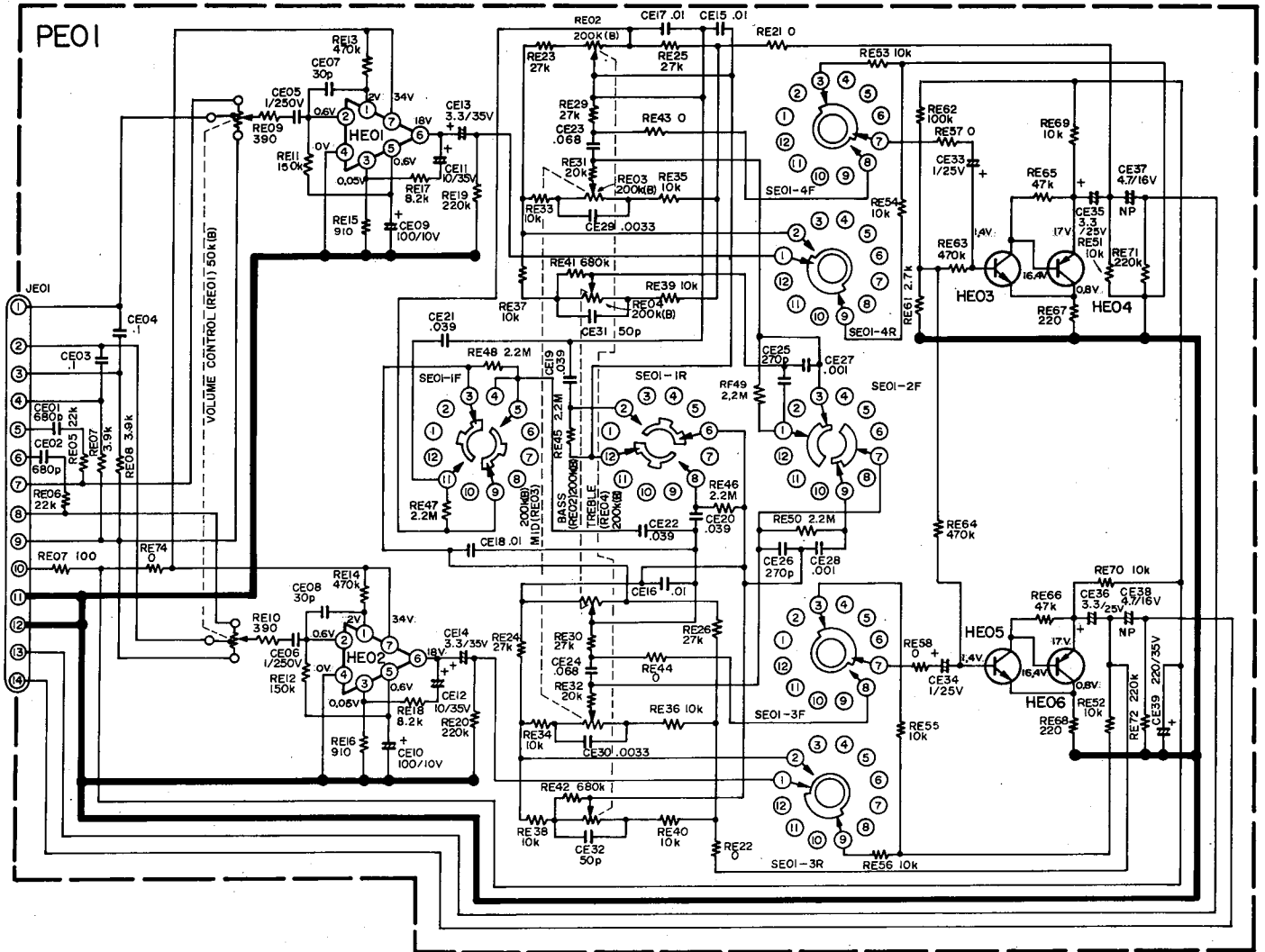

9.10 BUFFER AMPLIFIER CIRCUIT BOARD PH01

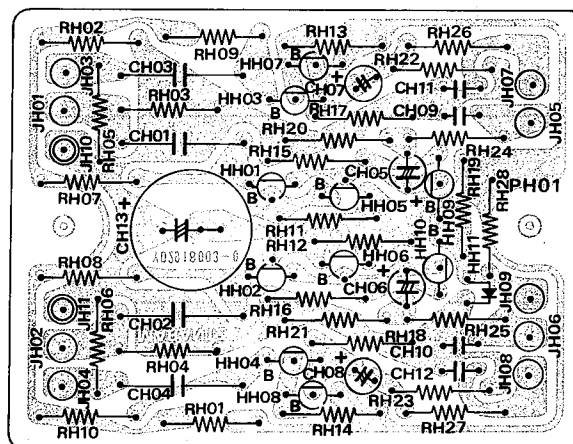
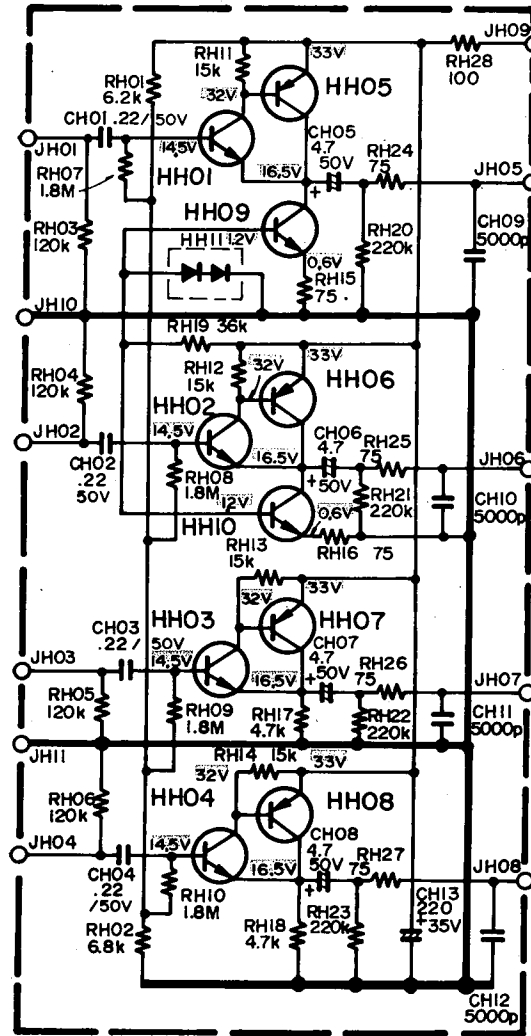

9.11 FUNCTION LAMP CIRCUIT BOARD PY01

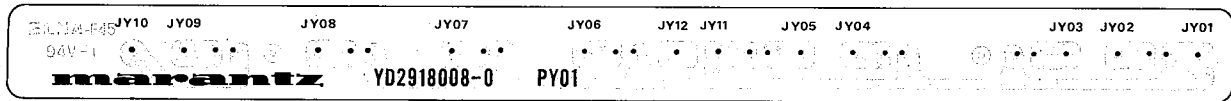
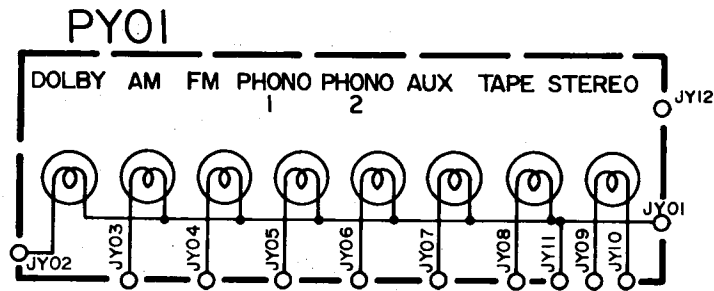

9.12 DIAL LAMP CIRCUIT BOARD PZ01

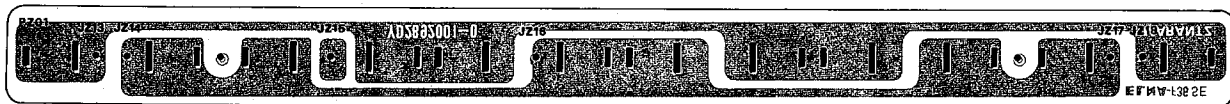
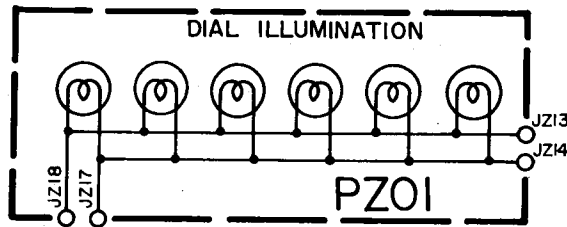

9.13 HI/LOW FILTERS, LOUDNESS AND SPEAKER SWITCHES CIRCUIT BOARD PU01

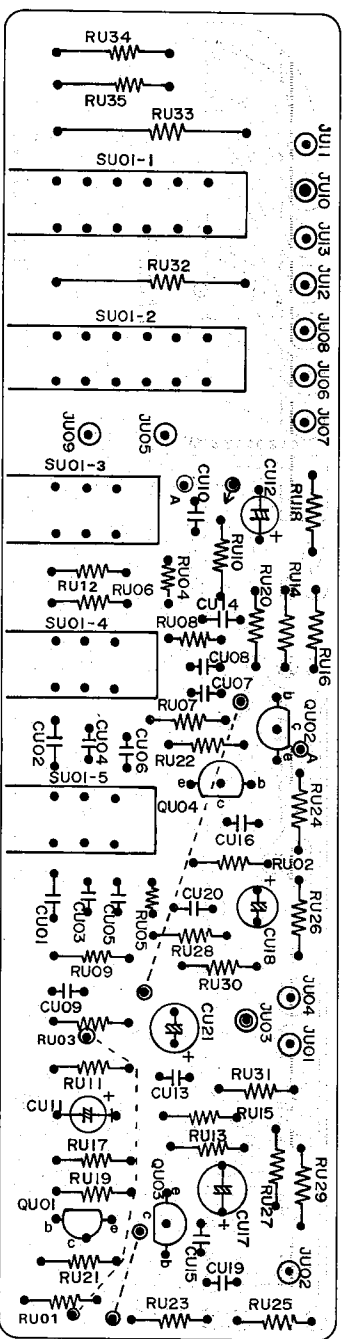
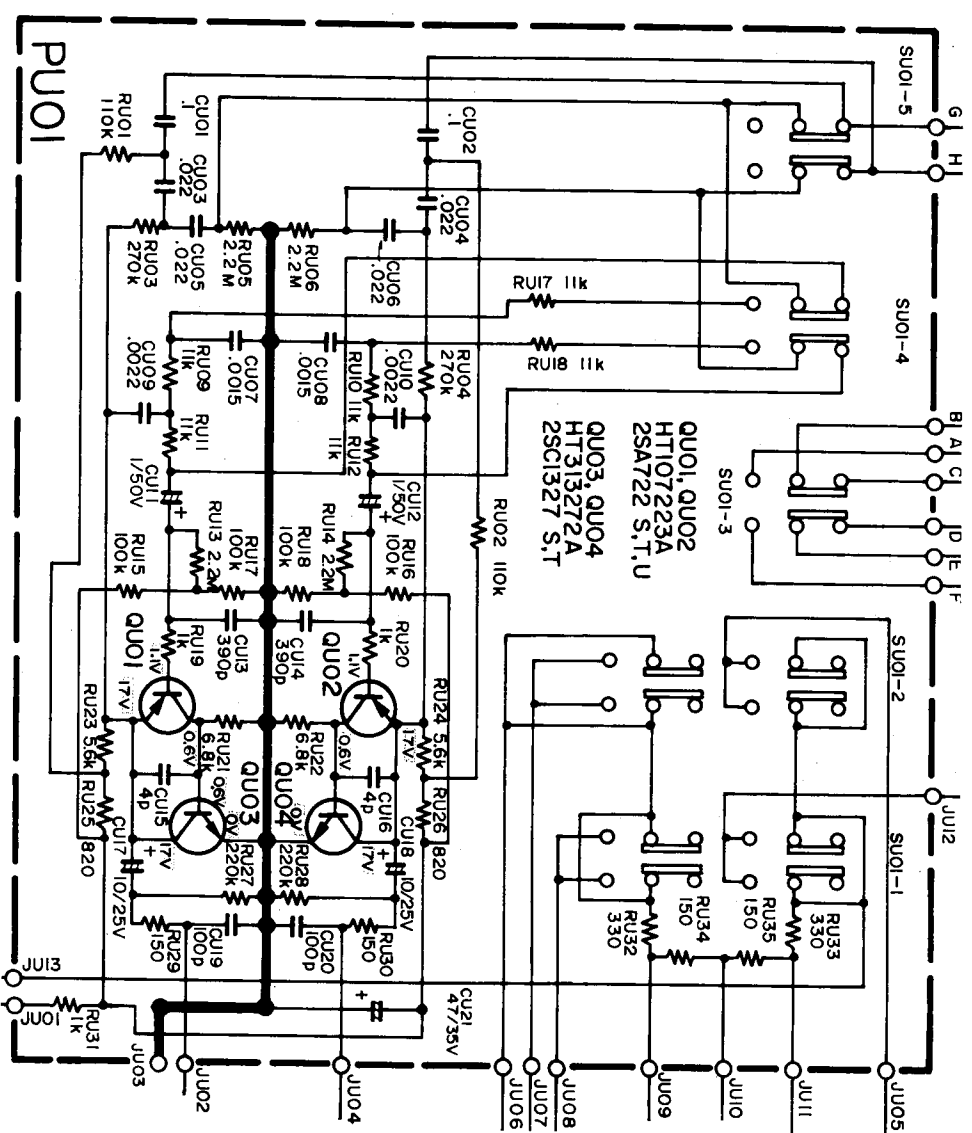

9.14 TAPE COPY, MPX NOISE FILTER, MULTIPATH AND FM MUTING SWITCHES CIRCUIT BOARD PT01

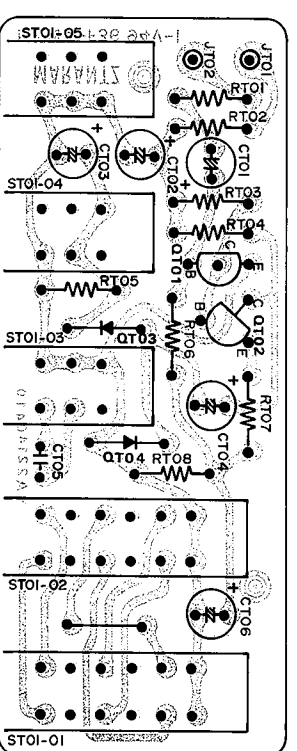
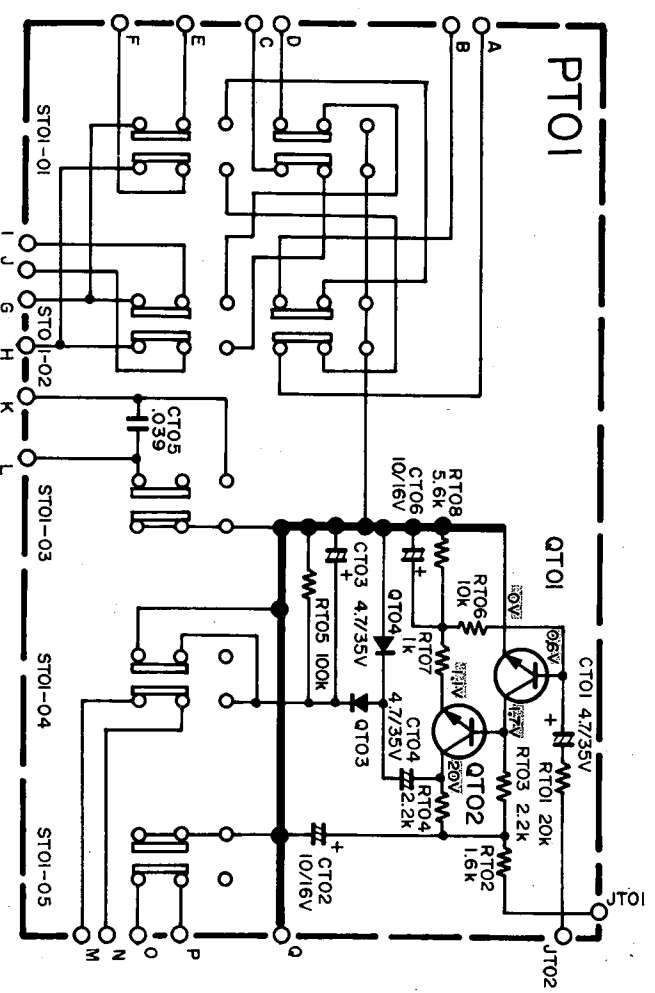

9.15 FM BALUN AND MUTING LEVEL CIRCUIT BOARD PC01

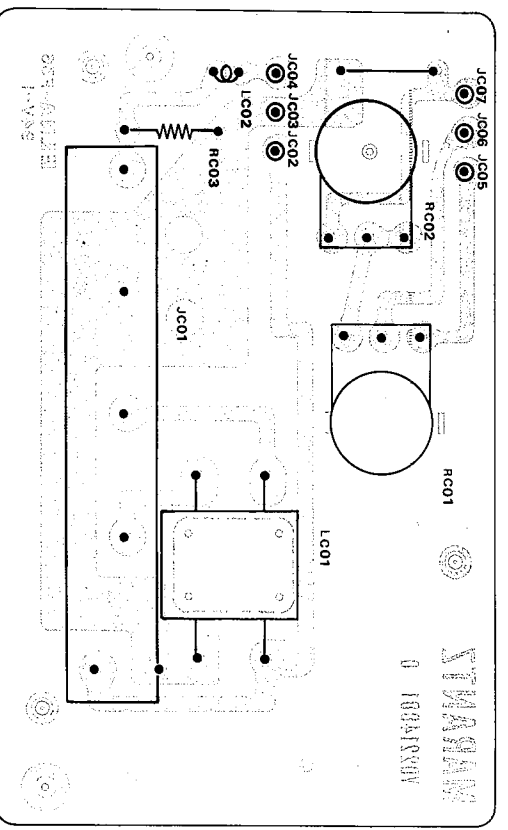
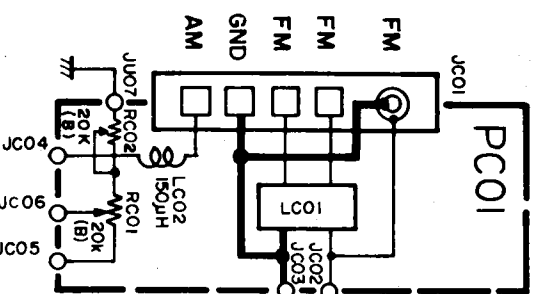

10.5 CABINET - FRONT VIEW - EUROPE

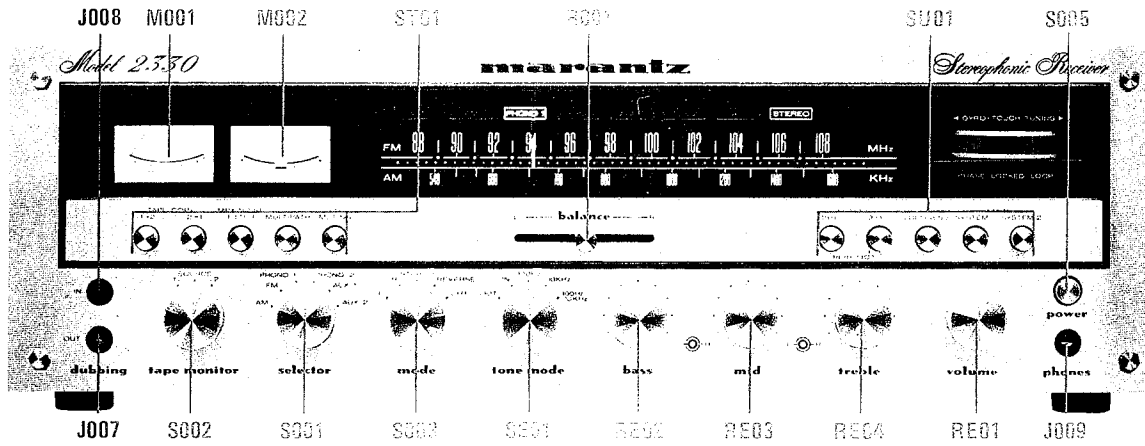

10.6 CHASSIS - TOP VIEW - EUROPE

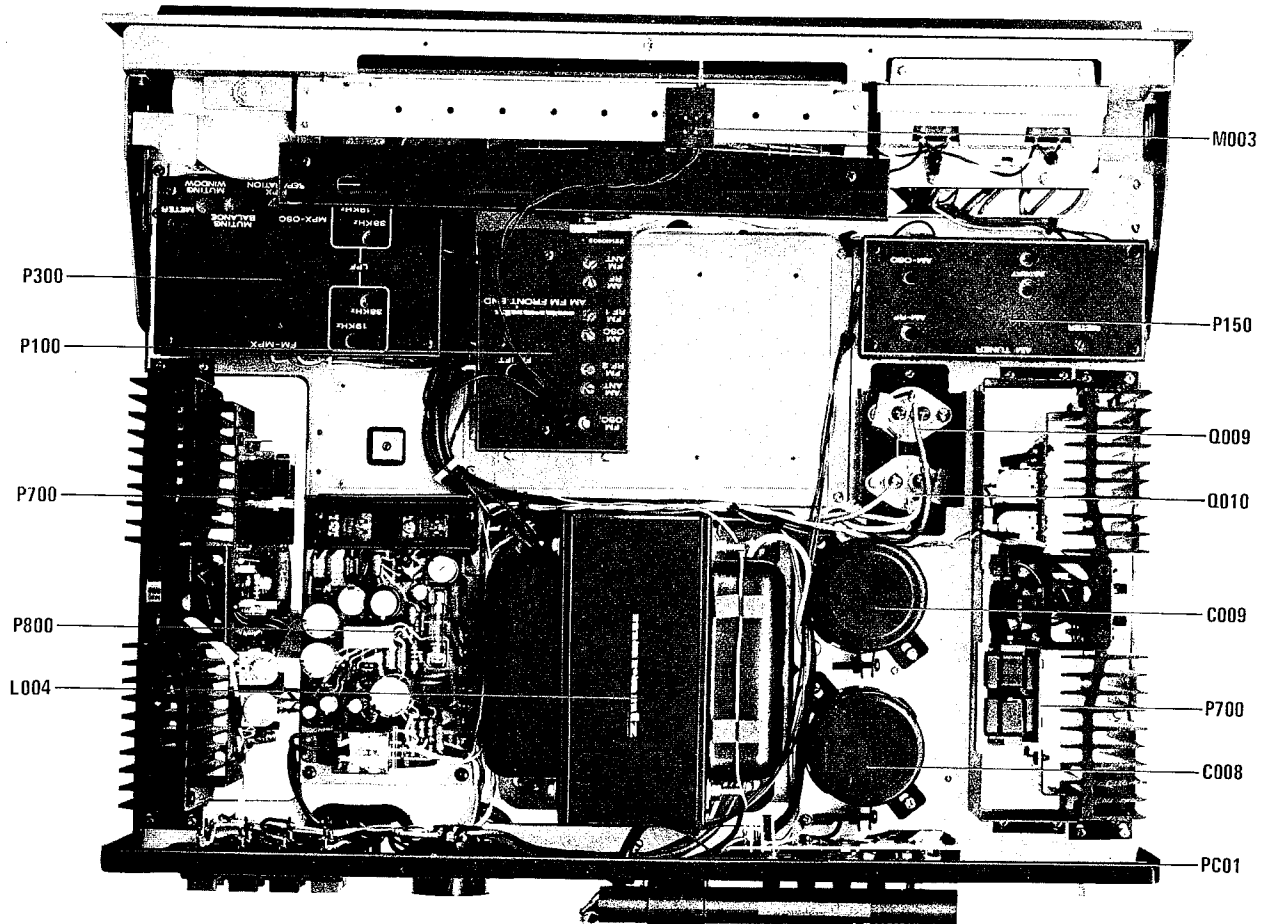

10.7 CABINET - REAR VIEW - EUROPE

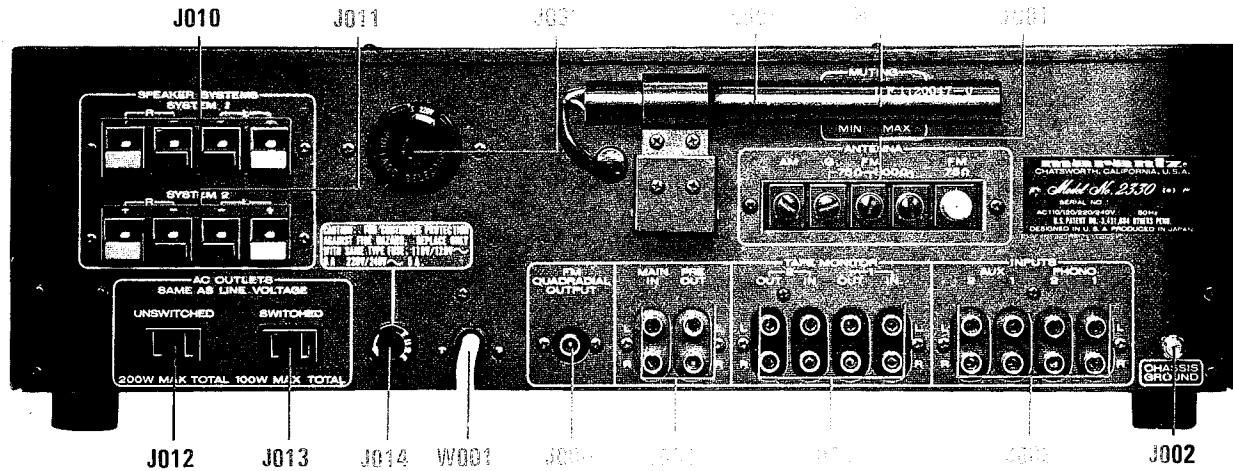

10.8 CHASSIS - BOTTOM VIEW - EUROPE

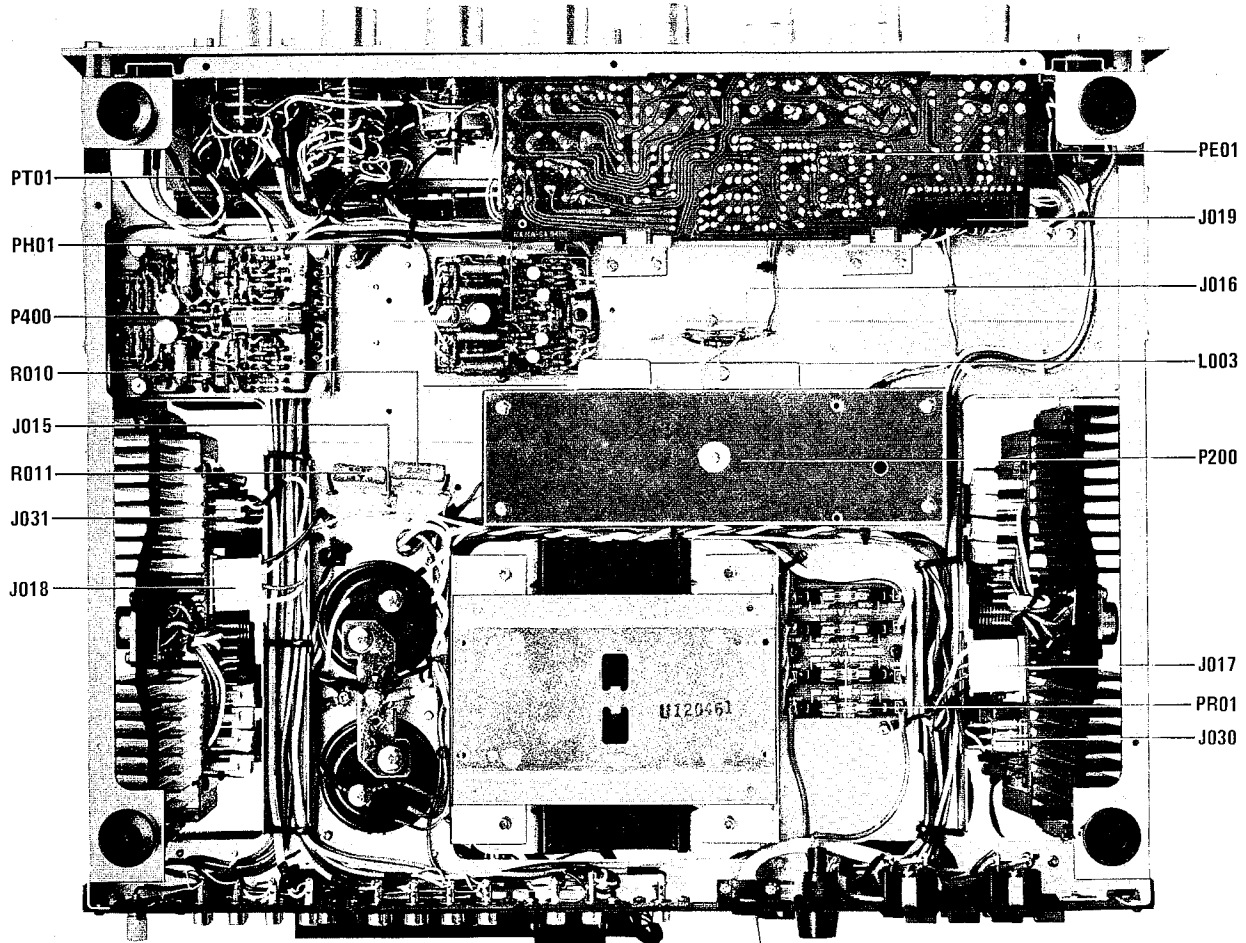

11.2 PACKING MATERIAL EXPLODED VIEW

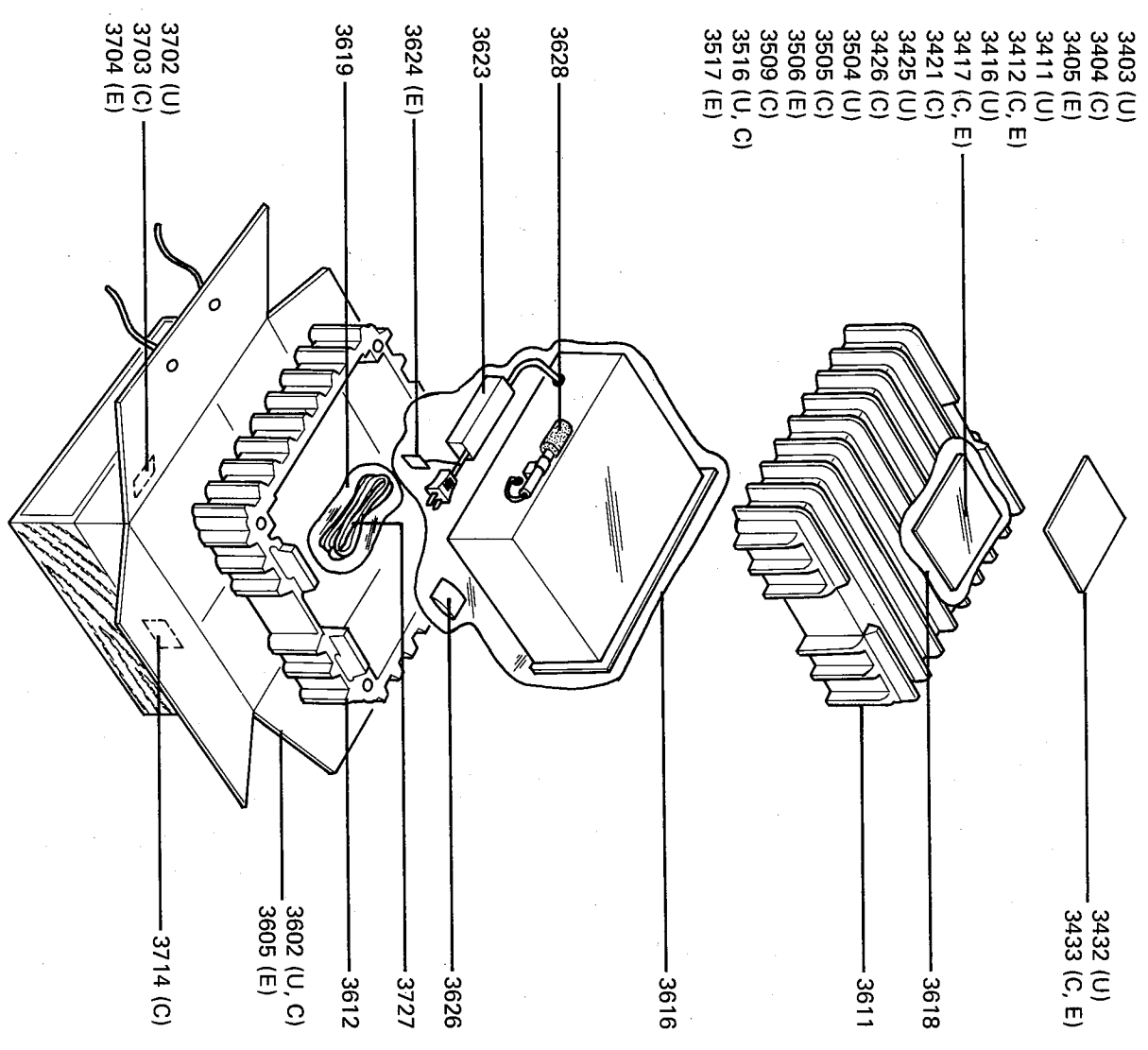

U: for U.S.A.
C: for Canada
E: for Europe

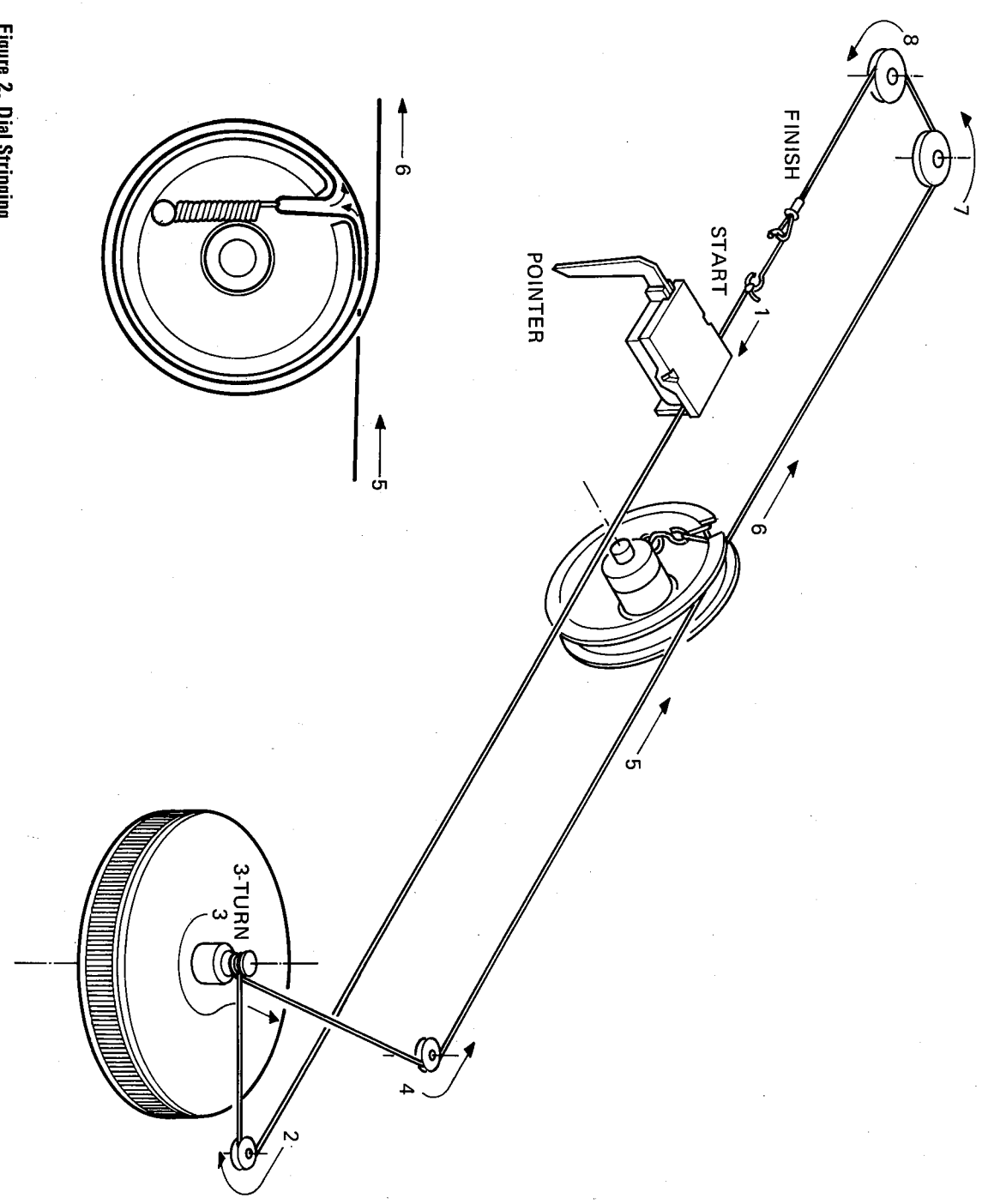

Figure 2. Dial Stringing

12. PARTS LIST

U: For U.S.A.
C: For Canada
E: For Europe

REF. DESIG.	Q'TY			PART NO.	DESCRIPTION
	U	C	E		
A	1	1		2214063400	Front Panel Assembly
A1			1	2214063410	Front Panel Assembly
1703	1	1		2214063013	Escutcheon
1704			1	2214063032	Escutcheon
1706	1	1	1	2214063023	Escutcheon
1708	1	1	1	2214401013	Frame
1710	1	1		2214158010	Window
1711			1	2214158020	Window
1713	10	10	10	2221259012	Bushing
1714	1	1	1	2886259010	Bushing
1716	1	1	1	2915107010	Sheet
1718	1	1	1	2918053010	Cover
B	1	1	1	2892257430	Lid Assembly, Upper
2903	1	1	1	2892257110	Lid
2904	4	4	4	2577118070	Spacer
2905	3	3	3	2892056020	Buffer
2906	2	2	2	2918056010	Buffer
C	1	1	1	2918257400	Lid Assembly, Lower
2912	1	1	1	2918257502	Lid K
2915	1	1	1	2915120010	Insulator
D	1	1	1	2214159400	Drum Assembly
0102	1	1	1	2214159010	Drum
0103	1	1	1	71101689L0	Spring
0105	2	2	2	51064019A9	Set Screw,
E	1	1	1	2915103420	Pointer Assembly
1820	1	1	1	2915103012	Pointer
1821	1	1	1	2850103010	Pointer
1822	1	1	1	2915103020	Cover
1823	1	1	1	2915267030	Heatsink
M003	1	1	1	IN10080300	Lamp, Dial Pointer
F	1	1	1	1202006420	Hook Assembly
1826	1	1	1	1202258010	Hook
1827	1	1	1	72071705D0	String
G	1	1	1	2853273400	Flywheel Assembly
1812	2	2	2	2577063022	Escutcheon
1813	1	1	1	2577273010	Flywheel
1814	1	1	1	2853112010	Shaft
1816	1	1	1	53110603E9	Hexagon Nut
1817	1	1	1	54020601E0	Flat Washer
H			1	2214160400	Rear Panel Assembly
1304			1	2214160230	Bracket
1309			1	2821259010	Bushing, AC Cord
1312			2	54050300R0	T.L. Washer
1314			2	55060305S0	T.R. Rivet
0201	1	1	1	2214160020	Bracket
0202	2	2		2214160030	Bracket
0203	4	4		51570306B0	P.H. Tapped Screw, P3x6ST
0204	3	3	3	51570306B0	P.H. Tapped Screw, P3x6ST
0205	4	4		51100306S9	B.H.M. Screw, B3x6
0301	2	2	2	2214267012	Heatsink
0302	16	16	16	54040302N0	Spring Washer
0303	16	16	16	51100316B9	B.H.M. Screw, B3x16
0304	4	4	4	2214160010	Bracket

REF. DESIG.	Q'TY			PART NO.	DESCRIPTION
	U	C	E		
0305	8	8	8	51280308U0	B.H. Tapped Screw B, 3x8
0308	4	4	4	2918104010	Retainer
0309	8	8	8	51280308U0	B.H. Tapped Screw B, 3x8
0310	8	8	8	51570306B0	P.H. Tapped Screw, P3x6ST
0402	2	2	2	2214267022	Heatsink
0403	4	4	4	51340308T0	F.H. Tapped Screw, F3x8ST
0404	2	2	2	51480310S9	B.H.M. Screw P, 3x10
0408	4	4	4	2212267020	Heatsink
0409	4	4	4	51100306S9	B.H.M. Screw, B3x6
0410	6	6	6	51280308U0	B.H. Tapped Screw B, 3x8
0414	4	4	4	2917267022	Heatsink
0415	4	4	4	51100310S9	B.H.M. Screw, B3x10
0416	4	4	4	53110303E9	Hexagon Nut
0417	4	4	4	54040302N0	Spring Washer
0421	2	2	2	2933101022	Support
0422	2	2	2	51100306S9	B.H.M. Screw, B3x6
0423	10	10	10	51100306S9	B.H.M. Screw, B3x6
0501	1	1	1	2918267022	Heatsink
0503	2	2	2	51100306S9	B.H.M. Screw, B3x6
0505	2	2	2	51100310E9	B.H.M. Screw, B3x10
0506	2	2	2	53110303E9	Hexagon Nut
0507	2	2	2	54050300R0	T.L. Washer OR
0508	2	2	2	54040302N0	Spring Washer
0509	2	2	2	54020301E0	Flat Washer P
0602	1	1	1	2918160504	Bracket K
0609	2	2	2	51100306A9	B.H.M. Screw, B3x6
0611	2	2	2	51100306A9	B.H.M. Screw, B3x6
0612	2	2	2	51100306A9	B.H.M. Screw, B3x6
0613	2	2	2	51100306A9	B.H.M. Screw, B3x6
0614	1			2214160050	Bracket
0616	3	3	3	51570305B0	P.H. Tapped Screw, P3x5ST
0618	2	2	2	51570305B0	P.H. Tapped Screw, P3x5ST
0620	1	1	1	2214120010	Insulator
0621	1	1	1	2214120020	Insulator
0622	1	1	1	2892122010	Sticker
0624	1	1	1	2918120020	Insulator
0626	2	2	2	51042608A0	F.H.M. Screw, F2.6x8
0702	2	2	2	51600306B0	P.H. Tapped Screw, P3x6ST
0706	2	2	2	2886107010	Sheet
0709	1	1	1	2904160072	Bracket
0710	1	1	1	2904160082	Bracket
0711	6	6	6	51100406A9	B.H.M. Screw, B4x6
0714	1	1	1	2892262512	Pulley K
0719	2	2	2	51100306A9	B.H.M. Screw, B3x6
0722	1	1	1	2577106020	Bearing
0723	1	1	1	1415118010	Spacer
0724	2	2	2	51040306A9	F.H.M. Screw, F3x6
0726	2	2	2	51490306A9	B.H.M. Screw S, 3x6
0728	2	2	2	2871053020	Cover
0803	1	1	1	2892274110	Reflector
0805	1	1	1	2892271010	Holder
0806	2	2	2	51570306B0	P.H. Tapped Screw, P3x6ST
0807	2	2	2	59030805P0	Washer
0809	1	1	1	2892271020	Holder
0810	2	2	2	51570306B0	P.H. Tapped Screw, P3x6ST
0812	2	2	2	51480306A9	B.H.M. Screw F, 3x6
0813	2	2	2	51100304A9	B.H.M. Screw, B3x4
0902	1	1	1	2886274012	Reflector
0904	1	1	1	2886271020	Holder
0905	2	2	2	51570306B0	P.H. Tapped Screw, P3x6ST
0906	2	2	2	51480306A9	B.H.M. Screw F, 3x6
1002	1	1	1	2918160050	Bracket

U: For U.S.A.
C: For Canada
E: For Europe

REF. DESIG.	Q'TY			PART NO.	DESCRIPTION
	U	C	E		
1011	1	1	1	2904160060	Bracket
1012	2	2	2	51100306A9	B.H.M. Screw, B3x6
1021	1	1	1	2918160060	Bracket
1022	1	1	1	62030039W0	Lug
1026	1	1	1	2214109050	Shield
1102	1	1	1	2892051012	Guide
1104	1	1	1	2892262520	Pulley K
1112	1	1	1	2892262530	Pulley K
1120	4	4	4	51570305B0	P.H. Tapped Screw, P3x5ST
1203	1	1	1	2853106500	Bearing K
1210	1	1	1	51640412A9	Set Screw C.P., 4x12
1211	1	1	1	54040402N0	Spring Washer
1212	1	1	1	53110403E9	Hexagon Nut
1302	1	1	1	2214160213	Bracket
1307	1	1	1	1455259030	Bushing, AC Cord
1311			2	53110303A9	Hexagon Nut
1313			2	51060316A9	P.H.M. Screw, P3x16
1402	4	4	4	51280308U0	B.H. Tapped Screw B, 3x8
1404	2	2	2	51280308U0	B.H. Tapped Screw B, 3x8
1406	8	8	8	51060308S9	P.H.M. Screw, P3x8
1407	8	8	8	53110303A9	Hexagon Nut
1412	3	3	3	51100306S9	B.H.M. Screw, B3x6
1414	1	1	1	1455259070	Bushing, Antenna Lead
1416			2	51100306S9	B.H.M. Screw, B3x6
1503	1	1	1	2578160522	Bracket K
1508	1	1	1	2819271130	Holder, Antenna
1510	2	2	2	51280312U0	B.H. Tapped Screw B, 3x12
1512	2	2	2	51280312U0	B.H. Tapped Screw B, 3x12
1602	2	2	2	51280308U0	B.H. Tapped Screw B, 3x8
1606	2	2	2	62040029W0	Lug
1610	1	1	1	62030039W0	Lug
1614	1	1	1	62030039W0	Lug
1720	1	1	1	2214302012	Dial
1721			1	2214302022	Dial
1723	1	1	1	2892107010	Sheet
1802	1	1	1	2917267032	Heatsink
1803	4	4	4	51100310B9	B.H.M. Screw, B3x10
1804	4	4	4	54040302N0	Spring Washer
1805	4	4	4	53110301E9	Hexagon Nut
1808	1	1	1	2918109050	Shield
1809	1	1	1	2918120010	Insulator
1830	1	1	1	9510601080	Label, 8 A 250 V
1912	1	1	1	1382005030	Clamper
1913	2	2	2	1382005030	Clamper
1914			1	1382005030	Clamper
1918	1	1	1	2918109070	Shield
1919	1	1	1	2889120050	Insulator
1920	2	2	2	2918120040	Insulator
2001	4	4	4	2759057012	Leg
2002	4	4	4	51490410S9	B.H.M. Screw F.S., 4x10
2006			1	2911861160	Label, Fuse Caution
2007			1	9510601080	Label, 8 A 250 V
2012	8	8	8	51060306S9	P.H.M. Screw, P3x6
2014	4	4	4	51100304A9	B.H.M. Screw, B3x4
2021	14	14	14	51570306B0	P.H. Tapped Screw, P3x6ST
2103	1	1	1	2214105502	Chassis K
2114	1	1	1	2214109010	Shield
2115	2	2	2	51570306B0	P.H. Tapped Screw, P3x6ST
2117	1	1	1	2214109020	Shield
2118	2	2	2	51570306B0	P.H. Tapped Screw, P3x6ST
2120	2	2	2	2892259010	Bushing
2202	4	4	4	51490614A9	B.H.M. Screw F.S., 6x14
2203	4	4	4	53110601A9	Hexagon Nut

REF. DESIG.	Q'TY			PART NO.	DESCRIPTION
	U	C	E		
2204	4	4	4	54020801A0	Flat Washer P
2216	4	4	4	51570408B0	P.H. Tapped Screw, P4x8ST
2218	1	1	1	2918160042	Bracket
2220	2	2	2	51100508E9	B.H.M. Screw, B5x8
2221	2	2	2	54020501E0	Flat Washer P
2222	2	2	2	54040502N0	Spring Washer
2224	2	2	2	51570408B0	P.H. Tapped Screw, P4x8ST
2225	2	2	2	54050400R0	T.L. Washer OR
2231	2	2	2	51100508E9	B.H.M. Screw, B5x8
2232	2	2	2	54040502N0	Spring Washer
2302	4	4	4	51100306S9	B.H.M. Screw, B3x6
2306	2	2	2	51570308B0	P.H. Tapped Screw, P3x8ST
2316	1	1	1	2918109012	Shield
2317	4	4	4	51570306B0	P.H. Tapped Screw, P3x6ST
2321	4	4	4	2888101022	Support
2322	4	4	4	2888101022	Support
2325	2	2	2	51570306B0	P.H. Tapped Screw, P3x6ST
2403	4	4	4	2856101020	Support
2404	1	1	1	2818101070	Support
2406	1	1	1	2856109022	Shield
2407	5	5	5	51100304E9	B.H.M. Screw, B3x4
2413	2	2	2	51100306S9	B.H.M. Screw, B3x6
2414	2	2	2	2886101050	Support
2415	2	2	2	54020301E0	Flat Washer P
2417	1	1	1	2916120050	Insulator
2431	2	2	2	2886160110	Bracket
2432	2	2	2	2886120090	Insulator
2433	4	4	4	51570306B0	P.H. Tapped Screw, P3x6ST
2503	1	1	1	51100306S9	B.H.M. Screw, B3x6
2504	1	1	1	2918101010	Support
2505	1	1	1	54020301E0	Flat Washer P
2516	1	1	1	2854160030	Bracket
2517	2	2	2	51570306B0	P.H. Tapped Screw, P3x6ST
2518	2	2	2	51100306S9	B.H.M. Screw, B3x6
2525	1	1	1	53110503A9	Hexagon Nut
2603	2	2	2	2818056030	Buffer
2607	1	1	1	51570306B0	P.H. Tapped Screw, P3x6ST
2609	1	1	1	1382005030	Clamper
2610	1	1	1	51600306B0	P.H. Tapped Screw, P3x6ST
2613	2	2	2	51600306B0	P.H. Tapped Screw, P3x6ST
2616	1	1	1	51600306B0	P.H. Tapped Screw, P3x6ST
2620	1	1	1	51600306B0	P.H. Tapped Screw, P3x6ST
2623	1	1	1	51570306B0	P.H. Tapped Screw, P3x6ST
2624	1	1	1	62030039W0	Lug
2626	1	1	1	51570306B0	P.H. Tapped Screw, P3x6ST
2628	1	1	1	51570306B0	P.H. Tapped Screw, P3x6ST
2629	1	1	1	62030039W0	Lug
2632	1	1	1	2886005060	Clamper
2633	3	3	3	2886005050	Clamper
2704			1	2911861160	Label, Caution
2705			1	9510221010	Label, Caution
2708	4	4	4	51570306B0	P.H. Tapped Screw, P3x6ST
2806	4	4	4	52017039J0	Bolt
2808	1	1	1	2916055010	Collar
2810	1	1	1	51340308P0	F.H. Tapped Screw, F3x8ST
2906	2	2	2	2918056010	Buffer
2907	4	4	4	51480406S9	B.H.M. Screw B4x6
2908	4	4	4	51122605S0	T.H.M. Screw, T2.6x5
2917	18	18	18	51100406S9	B.H.M. Screw, B4x6
2919	2	2	2	2918160070	Bracket
2920	2	2	2	2918120050	Insulator
3003	1	1	1	2221154112	Knob, Volume
3004	10	10	10	2221154122	Knob, Pushswitch

U : For U.S.A.
 C : For Canada
 E : For Europe

REF. DESIG.	Q'TY			PART NO.	DESCRIPTION
	U	C	E		
3005	5	5	5	2221154133	Knob, Pushswitch
3009	3	3	3	2210154023	Knob
3011	3	3	3	2210154013	Knob
3013	1	1	1	2904154140	Knob, Power Switch
3103	1			2214265010	Indicator
3104		1		2214265020	Indicator
3105			1	2214265030	Indicator
3112	2	2	2	51280308U0	B.H. Tapped Screw B, 3x8
3116	1	1	1	2578861010	Label, UL Caution
3117		1		2911861110	Label, UL Caution
3118	1	1	1	2932861010	Label, Do not remove cover.
3119	1	1	1	2911861140	Label, Do not remove cover.
3120	1	1	1	2506265060	Indicator, Do not use as handle.
3121		1		2911861170	Label
3123	1			9511101020	Label, UL
3124	1			9510911020	Label, UL Factory
3126		1		9510911010	Label, LL No.
3127		1		2911861190	Label, Disconnect supply....
3133	1	1	1	2886861010	Label, Marantz
3203	1	1	1	2850112020	Shaft
3204	1	1	1	54040402N0	Spring Washer
3207	1	1	1	2214109032	Shield
3208	3	3	3	51100306S9	B.H.M. Screw, B3x6
3210	1	1	1	2908259010	Bushing
3214	1	1	1	2873118020	Spacer
3217	1	1	1	2892269020	Protector
3218	2	2	2	51570306B0	P.H. Tapped Screw, P3x6ST
3221	1	1	1	2918269014	Protector
3222	2	2	2	51570306B0	P.H. Tapped Screw, P3x6ST
3225	1	1	1	2819120050	Insulator
3231	1	1	1	2892269010	Protector
3232	2	2	2	51100304S9	B.H.M. Screw, B3x4
3305	1	1	1	2889109043	Shield
3306	4	4	4	51100304S9	B.H.M. Screw, B3x4
3311	1	1	1	2214109040	Shield
3312	4	4	4	51100306S9	B.H.M. Screw, B3x6
3325	1	1	1	56382540G0	Eyelet
3403	1			2577813010	Envelope, Guarantee
3404		1		2918813012	Envelope, Guarantee
3405			1	2818813010	Envelope, Guarantee
3411	1			2577851020	Instructions, Important
3412		1	1	2818851120	Instructions, Important
3416	1			2577854012	Guarantee Card, IBM
3417	1	1	1	9630000180	Guarantee Card, IBM
3421		1		9650000050	Service Station Card
3425	1			2818854022	Guarantee Card
3426		1		2818854040	Guarantee Card
3432	1			2818851040	Instructions, Packing
3433		1	1	2818851140	Instructions, Packing
3504	1			2214851010	Instructions, Set
3505		1		2214851310	Instructions, Set
3506			1	2214851320	Instructions, Set
3509		1		2886851100	Instructions, Flysheet
3516	1	1	1	2214856010	Schematic Diagram
3517			1	2214856020	Schematic Diagram
3602	1	1	1	2214801010	Packing Case, Inner
3603	1	1	1	2214801110	Packing Case, Outer
3605			1	2214801020	Packing Case, Inner
3606			1	2214801120	Packing Case, Outer
3611	1	1	1	2892803010	Cushion, Upper
3612	1	1	1	2892803020	Cushion, Lower
3616	1	1	1	9015345430	Polyethylene Bag, Set
3618	1	1	1	9013025010	Polyethylene Bag, Printed Matter

REF. DESIG.	Q'TY			PART NO.	DESCRIPTION
	U	C	E		
3619	1	1	1	9013025010	Polyethylene Bag, Accessories
3623	1	1	1	2864804010	Sleeve, AC Cord
3624			1	9560000042	Hang Tag
3626	1	1	1	2731821010	Silicagel
3628	1	1	1	2819056010	Buffer, AM Rod-Antenna
3702	4			9522815010	Serial No. Card
3703		4		9523015120	Serial No. Card
3704			4	9523015110	Serial No. Card
3714		2		9510901020	Label
3727	1	1	1	ZA02000070	External Antenna
FM FRONT END CIRCUIT BOARD - P100					
P100	1	1	1	YD29920010	P.W. Board, FM Front End
A001	1	1	1	AV01202070	FM Front End Assembly
P100 - RESISTORS					
R101	1	1	1	GD05104140	Fixed, 100kΩ ±5%, ¼W
R102	1	1	1	GD05470140	Fixed, 47Ω ±5%, ¼W
R103	1	1	1	GD05104140	Fixed, 100kΩ ±5%, ¼W
R104	1	1	1	GD05105140	Fixed, 1MΩ ±5%, ¼W
R105	1	1	1	GD05681140	Fixed, 680Ω ±5%, ¼W
R106	1	1	1	GD05153140	Fixed, 15kΩ ±5%, ¼W
R107	1	1	1	GD05472140	Fixed, 4.7kΩ ±5%, ¼W
R108	1	1	1	GD05103140	Fixed, 10kΩ ±5%, ¼W
R109	1	1	1	GD05821140	Fixed, 820Ω ±5%, ¼W
R110	1	1	1	GD05101140	Fixed, 100Ω ±5%, ¼W
R111	1	1	1	GD05101140	Fixed, 100Ω ±5%, ¼W
R112	1	1	1	GD05330140	Fixed, 33Ω ±5%, ¼W
P100 - CAPACITORS					
C101	1	1	1	CA43700020	Variable, FM-4, AM-3
C102	1	1	1	DD16120020	Ceramic, 12pF ±10%
C103	1	1	1	DD16101010	Ceramic, 100pF ±10%
C104	1	1	1	DD15200010	Ceramic, 20pF ±5%
C105	1	1	1	DK18203030	Ceramic, 0.02μF +80%, -20%
C106	1	1	1	DK18203030	Ceramic, 0.02μF +80%, -20%
C107	1	1	1	DD16120020	Ceramic, 12pF ±10%
C108	1	1	1	DD16120020	Ceramic, 12pF ±10%
C109	1	1	1	DD10010020	Ceramic, 1pF ±0.25pF
C110	1	1	1	DD16150040	Ceramic, 15pF ±10%
C111	1	1	1	DD16082010	Ceramic, 8.2pF ±10%
C112	1	1	1	DD16470020	Ceramic, 47pF ±10%
C113	1	1	1	DD16150030	Ceramic, 15pF ±10%
C114	1	1	1	DK18203030	Ceramic, 0.02μF +80%, -20%
C115	1	1	1	DK18203030	Ceramic, 0.02μF +80%, -20%
C116	1	1	1	DK18203030	Ceramic, 0.02μF +80%, -20%
P100 - MISCELLANEOUS					
Q101	1	1	1	HF400451B0	FET, 3SK45 (B)
Q102	1	1	1	HF400591A0	FET, 3SK59 (Y)
Q103	1	1	1	HT307101C0	Transistor, 2SC710 (C)
L106	1	1	1	LI70039010	IFT, TM122
L107	1	1	1	LC13920010	Choke Coil, WU111
J101	1	1	1	YJ06001150	Plug
J102	1	1	1	YJ06001150	Plug
AM TUNER CIRCUIT BOARD - P150					
P150	1	1	1	YA29590310	P.W. Board, AM Tuner
	1	1	1	ZZ29590310	P.W. Board Assembly

U: For U.S.A.
C: For Canada
E: For Europe

REF. DESIG.	Q'TY			PART NO.	DESCRIPTION
	U	C	E		
P150 - RESISTORS					
R151	1	1	1	RT05103141	Fixed, 10kΩ ±5%, ¼W
R152	1	1	1	RT05303141	Fixed, 30kΩ ±5%, ¼W
R153	1	1	1	RT05823141	Fixed, 82kΩ ±5%, ¼W
R154	1	1	1	RT05223141	Fixed, 22kΩ ±5%, ¼W
R156	1	1	1	RT05104141	Fixed, 100kΩ ±5%, ¼W
R158	1	1	1	RT05393141	Fixed, 39kΩ ±5%, ¼W
R159	1	1	1	RT05392141	Fixed, 3.9kΩ ±5%, ¼W
R161	1	1	1	RT05432141	Fixed, 4.3kΩ ±5%, ¼W
R162	1	1	1	RT05101141	Fixed, 100Ω ±5%, ¼W
R163	1	1	1	RT05152141	Fixed, 1.5kΩ ±5%, ¼W
R164	1	1	1	RT05331141	Fixed, 330Ω ±5%, ¼W
R167	1	1	1	RT05222140	Fixed, 2.2kΩ ±5%, ¼W
R168	1	1	1	RT05823141	Fixed, 82kΩ ±5%, ¼W
R169	1	1	1	RT05624141	Fixed, 620kΩ ±5%, ¼W
R170	1	1	1	RT05511141	Fixed, 510Ω ±5%, ¼W
R171	1	1	1	RT05222141	Fixed, 2.2kΩ ±5%, ¼W
R172	1	1	1	RT05562141	Fixed, 5.6kΩ ±5%, ¼W
R173	1	1	1	RT05102141	Fixed, 1kΩ ±5%, ¼W
R174	1	1	1	RT05101141	Fixed, 100Ω ±5%, ¼W
R175	1	1	1	RT05104141	Fixed, 100kΩ ±5%, ¼W
R176	1	1	1	RT05103141	Fixed, 10kΩ ±5%, ¼W
R177	1	1	1	RT05123141	Fixed, 12kΩ ±5%, ¼W
R178	1	1	1	RA01030250	Trimming, 10kΩ (B)
R179	1	1	1	RT05103141	Fixed, 10kΩ ±5%, ¼W
R180	1	1	1	RT05152141	Fixed, 1.5kΩ ±5%, ¼W
R181	1	1	1	RT05101140	Fixed, 100Ω ±5%, ¼W
R182	1	1	1	RT05152141	Fixed, 1.5kΩ ±5%, ¼W
P150 - CAPACITORS					
C151	1	1	1	DK17103010	Ceramic, 0.01μF ±20%
C152	1	1	1	DF17473050	Film, 0.047μF ±20%
C153	1	1	1	DD16200010	Ceramic, 20pF ±10%
C154	1	1	1	DK17103010	Ceramic, 0.01μF ±20%
C155	1	1	1	DF65391010	Film, 390pF ±5%
C156	1	1	1	DD16150010	Ceramic, 15pF ±10%
C157	1	1	1	DK17103010	Ceramic, 0.01μF ±20%
C158	1	1	1	DK18403020	Ceramic, 0.04μF +80%,-20%
C159	1	1	1	DK18403020	Ceramic, 0.04μF +80%,-20%
C160	1	1	1	DK17103010	Ceramic, 0.01μF ±20%
C161	1	1	1	DK17103010	Ceramic, 0.01μF ±20%
C162	1	1	1	DK17103010	Ceramic, 0.01μF ±20%
C163	1	1	1	DF16153050	Film, 0.015μF ±10%
C164	1	1	1	DF16333050	Film, 0.033μF ±10%
C165	1	1	1	DF17562050	Film, 5600pF ±20%
C166	1	1	1	DK18403020	Film, 0.04μF +80%,-20%
C167	1	1	1	EA22601690	Electrolytic, 22μF, 16V
C168	1	1	1	EA10701690	Electrolytic, 100μF, 16V
C169	1	1	1	EA47503590	Electrolytic, 4.7μF, 35V
C170	1	1	1	EA10701690	Electrolytic, 100μF, 16V
C171	1	1	1	EE10505010	Electrolytic, 1μF, 50V
C172	1	1	1	EA10701690	Electrolytic, 100μF, 16V
C173	1	1	1	EA47503590	Electrolytic, 4.7μF, 35V
P150 - MISCELLANEOUS					
Q151	1	1	1	HC10005060	IC, μPC30
Q152	1	1	1	HT313272A0	Transistor, 2SC1327 S or T
Q153	1	1	1	HT108422A0	Transistor, 2SA842 (Gr, Bl)
Q154	1	1	1	HT104952A0	Transistor, 2SA495 O or Y
Q155	1	1	1	HH00002120	Thermistor, 31D27
L151	1	1	1	LA10010190	RF Coil, AM
L152	1	1	1	LO10010500	OSC Coil, AM
L153	1	1	1	LI10280030	IFT, AM
L154	1	1	1	LC13320020	Choke Coil, 3.3μH

REF. DESIG.	Q'TY			PART NO.	DESCRIPTION
	U	C	E		
L155	1	1	1	LC13320020	Choke Coil, 3.3μH
J151	1	1	1	YP10001130	Plug
J152	1	1	1	YP10001130	Plug
J153	1	1	1	YP10001130	Plug
J155	1	1	1	YP10001130	Plug
J156	1	1	1	YP10001130	Plug
J157	1	1	1	YP10001130	Plug
J158	1	1	1	YP10001130	Plug
J160	1	1	1	YP10001130	Plug
J161	1	1	1	YP10001130	Plug
P158	2	2	2	2933118020	Spacer, R181
P161	4	4	4	75061251P0	Jumper Wire,
FM IF CIRCUIT BOARD - P200					
P200	1	1	1	YD22120030	P.W. Board, FM IF
	1	1	1	ZZ22120030	P.W. Board Assembly
P200 - RESISTORS					
R201	1	1	1	RT05151140	Fixed, 150Ω ±5%, ¼W
R202	1	1	1	RT05822140	Fixed, 8.2kΩ ±5%, ¼W
R203	1	1	1	RT05183140	Fixed, 18kΩ ±5%, ¼W
R204	1	1	1	RT05102140	Fixed, 1kΩ ±5%, ¼W
R205	1	1	1	RT05331140	Fixed, 330Ω ±5%, ¼W
R206	1	1	1	RT05301140	Fixed, 300Ω ±5%, ¼W
R207	1	1	1	RT05470140	Fixed, 47Ω ±5%, ¼W
R208	1	1	1	RT05102140	Fixed, 1kΩ ±5%, ¼W
R209	1	1	1	RT05471140	Fixed, 470Ω ±5%, ¼W
R210	1	1	1	RT05151140	Fixed, 150Ω ±5%, ¼W
R212	1	1	1	RT05102140	Fixed, 1kΩ ±5%, ¼W
R213	1	1	1	RT05331140	Fixed, 330Ω ±5%, ¼W
R214	1	1	1	RT05301140	Fixed, 300Ω ±5%, ¼W
R215	1	1	1	RT05470140	Fixed, 47Ω ±5%, ¼W
R216	1	1	1	RT05102140	Fixed, 1kΩ ±5%, ¼W
R217	1	1	1	RT05471140	Fixed, 470Ω ±5%, ¼W
R218	1	1	1	RT05151140	Fixed, 150Ω ±5%, ¼W
R219	1	1	1	RT05102140	Fixed, 1kΩ ±5%, ¼W
R220	1	1	1	RT05151140	Fixed, 150Ω ±5%, ¼W
R221	1	1	1	RT05750140	Fixed, 75Ω ±5%, ¼W
R223	1	1	1	RT05153140	Fixed, 15kΩ ±5%, ¼W
R224	1	1	1	RC00000140	Fixed, 0Ω, ¼W
R225	1	1	1	RT05152140	Fixed, 1.5kΩ ±5%, ¼W
R226	1	1	1	RT05332140	Fixed, 3.3kΩ ±5%, ¼W
R227	1	1	1	RT05151140	Fixed, 150Ω ±5%, ¼W
R228	1	1	1	RT05561140	Fixed, 560Ω ±5%, ¼W
R229	1	1	1	RT05221140	Fixed, 220Ω ±5%, ¼W
R230	1	1	1	RT05750140	Fixed, 75Ω ±5%, ¼W
R231	1	1	1	RT05750140	Fixed, 75Ω ±5%, ¼W
R232	1	1	1	RT05104140	Fixed, 100kΩ ±5%, ¼W
R234	1	1	1	RT05683140	Fixed, 68kΩ ±5%, ¼W
R235	1	1	1	RT05470140	Fixed, 47Ω ±5%, ¼W
R236	1	1	1	RT05821140	Fixed, 820Ω ±5%, ¼W
R237	1	1	1	RT05102140	Fixed, 1kΩ ±5%, ¼W
R238	1	1	1	RT05821140	Fixed, 820Ω ±5%, ¼W
R239	1	1	1	RT05152140	Fixed, 1.5kΩ ±5%, ¼W
R240	1	1	1	RT05332140	Fixed, 3.3kΩ ±5%, ¼W
R241	1	1	1	RT05151140	Fixed, 150Ω ±5%, ¼W
R242	1	1	1	RT05102140	Fixed, 1kΩ ±5%, ¼W
R243	1	1	1	RT05102140	Fixed, 1kΩ ±5%, ¼W
R244	1	1	1	RT05151140	Fixed, 150Ω ±5%, ¼W
R246	1	1	1	RT05683140	Fixed, 68kΩ ±5%, ¼W

U: For U.S.A.
C: For Canada
E: For Europe

REF. DESIG.	Q'TY			PART NO.	DESCRIPTION
	U	C	E		
R248	1	1	1	RT05470140	Fixed, 47Ω ±5%, ¼W
R249	1	1	1	RT05151140	Fixed, 150Ω ±5%, ¼W
R250	1	1	1	RT05104140	Fixed, 100kΩ ±5%, ¼W
R251	1	1	1	RT05822140	Fixed, 8.2kΩ ±5%, ¼W
R252	1	1	1	RT05153140	Fixed, 15kΩ ±5%, ¼W
R253	1	1	1	RT05102140	Fixed, 1kΩ ±5%, ¼W
R254	1	1	1	RT05102140	Fixed, 1kΩ ±5%, ¼W
R255	1	1	1	RT05151140	Fixed, 150Ω ±5%, ¼W
R257	1	1	1	RT05473140	Fixed, 47kΩ ±5%, ¼W
R258	1	1	1	RT05223140	Fixed, 22kΩ ±5%, ¼W
R259	1	1	1	RT05821140	Fixed, 820Ω ±5%, ¼W
R260	1	1	1	RT05104140	Fixed, 100kΩ ±5%, ¼W
R261	1	1	1	RT05151140	Fixed, 150Ω ±5%, ¼W
R262	1	1	1	RT05822140	Fixed, 8.2kΩ ±5%, ¼W
R263	1	1	1	RT05153140	Fixed, 15kΩ ±5%, ¼W
R264	1	1	1	RT05102140	Fixed, 1kΩ ±5%, ¼W
R265	1	1	1	RT05102140	Fixed, 1kΩ ±5%, ¼W
R266	1	1	1	RT05101140	Fixed, 100Ω ±5%, ¼W
R267	1	1	1	RT05151140	Fixed, 150Ω ±5%, ¼W
R268	1	1	1	RT05151140	Fixed, 150Ω ±5%, ¼W
R269	1	1	1	RT05104140	Fixed, 100kΩ ±5%, ¼W
R270	1	1	1	RT05822140	Fixed, 8.2kΩ ±5%, ¼W
R271	1	1	1	RT05153140	Fixed, 15kΩ ±5%, ¼W
R272	1	1	1	RT05102140	Fixed, 1kΩ ±5%, ¼W
R273	1	1	1	RT05101140	Fixed, 100Ω ±5%, ¼W
R274	1	1	1	RT05272140	Fixed, 2.7kΩ ±5%, ¼W
R275	1	1	1	RT05821140	Fixed, 820Ω ±5%, ¼W
R276	1	1	1	RT05821140	Fixed, 820Ω ±5%, ¼W
R277	1	1	1	RT05821140	Fixed, 820Ω ±5%, ¼W
R278	1	1	1	RT05682140	Fixed, 6.8kΩ ±5%, ¼W
R279	1	1	1	RT05682140	Fixed, 6.8kΩ ±5%, ¼W
R280	1	1	1	RT05101140	Fixed, 100Ω ±5%, ¼W
R281	1	1	1	RT05623140	Fixed, 62kΩ ±5%, ¼W
R282	1	1	1	RT05273140	Fixed, 27kΩ ±5%, ¼W
R283	1	1	1	RT05101140	Fixed, 100Ω ±5%, ¼W
R284	1	1	1	RT05104140	Fixed, 100kΩ ±5%, ¼W
R285	1	1	1	RT05184140	Fixed, 180kΩ ±5%, ¼W
R286	1	1	1	RT05101140	Fixed, 100Ω ±5%, ¼W
R287	1	1	1	RT05222140	Fixed, 2.2kΩ ±5%, ¼W
R288	1	1	1	RT05101140	Fixed, 100Ω ±5%, ¼W
R289	1	1	1	RT05101140	Fixed, 100Ω ±5%, ¼W
R290	1	1	1	RT05121140	Fixed, 120Ω ±5%, ¼W
R291	1	1	1	RT05822140	Fixed, 8.2kΩ ±5%, ¼W
R292	1	1	1	RT05183140	Fixed, 18kΩ ±5%, ¼W
R293	1	1	1	RT05222140	Fixed, 2.2kΩ ±5%, ¼W
R294	1	1	1	RT05273140	Fixed, 27kΩ ±5%, ¼W
R295	1	1	1	RT05273140	Fixed, 27kΩ ±5%, ¼W
R296	1	1	1	RT05333140	Fixed, 33kΩ ±5%, ¼W
R298	1	1	1	RT05474140	Fixed, 470kΩ ±5%, ¼W
P200 - CAPACITORS					
C201	1	1	1	DK18103010	Ceramic, 0.01μF +80%, -20%
C202	1	1	1	DK18103010	Ceramic, 0.01μF +80%, -20%
C203	1	1	1	DK18403020	Ceramic, 0.04μF +80%, -20%
C204	1	1	1	EA10601690	Electrolytic, 10μF, 16V
C205	1	1	1	EA10601690	Electrolytic, 10μF, 16V
C206	1	1	1	DK18403020	Ceramic, 0.04μF +80%, -20%
C207	1	1	1	DK18103010	Ceramic, 0.01μF +80%, -20%
C208	1	1	1	EA10601690	Electrolytic, 10μF, 16V
C209	1	1	1	DK18403020	Ceramic, 0.04μF +80%, -20%
C210	1	1	1	DK18103010	Ceramic, 0.01μF +80%, -20%
C211	1	1	1	DD15400010	Ceramic, 40pF ±5%
C213	1	1	1	DK18103010	Ceramic, 0.01μF +80%, -20%

REF. DESIG.	Q'TY			PART NO.	DESCRIPTION
	U	C	E		
C214	1	1	1	DD15400010	Ceramic, 40pF ±5%
C215	1	1	1	DK18103010	Ceramic, 0.01μF +80%, -20%
C217	1	1	1	DK18403020	Ceramic, 0.04μF +80%, -20%
C218	1	1	1	EA10601690	Electrolytic, 10μF, 16V
C219	1	1	1	EA10601690	Electrolytic, 10μF, 16V
C220	1	1	1	DK18403020	Ceramic, 0.04μF +80%, -20%
C221	1	1	1	DK18103010	Ceramic, 0.01μF +80%, -20%
C222	1	1	1	DK18103010	Ceramic, 0.01μF +80%, -20%
C223	1	1	1	DD15400010	Ceramic, 40pF ±5%
C225	1	1	1	DK18103010	Ceramic, 0.01μF +80%, -20%
C226	1	1	1	DK18103010	Ceramic, 0.01μF +80%, -20%
C227	1	1	1	DK18103010	Ceramic, 0.01μF +80%, -20%
C228	1	1	1	DD15400010	Ceramic, 40pF ±5%
C229	1	1	1	EA10601690	Electrolytic, 10μF, 16V
C230	1	1	1	DK18403020	Ceramic, 0.04μF +80%, -20%
C232	1	1	1	DK18103010	Ceramic, 0.01μF +80%, -20%
C233	1	1	1	DD15400010	Ceramic, 40pF ±5%
C234	1	1	1	DK18103010	Ceramic, 0.01μF +80%, -20%
C235	1	1	1	DK18103010	Ceramic, 0.01μF +80%, -20%
C236	1	1	1	DK18103010	Ceramic, 0.01μF +80%, -20%
C237	1	1	1	DK18103010	Ceramic, 0.01μF +80%, -20%
C238	1	1	1	DK18403020	Ceramic, 0.04μF +80%, -20%
C239	1	1	1	DD16201010	Ceramic, 200pF ±10%
C240	1	1	1	DD16201010	Ceramic, 200pF ±10%
C241	1	1	1	DD16201010	Ceramic, 200pF ±10%
C242	1	1	1	EA10601690	Electrolytic, 10μF, 16V
C243	1	1	1	EA10701090	Electrolytic, 100μF, 10V
C244	1	1	1	EA10601690	Electrolytic, 10μF, 16V
C245	1	1	1	EA10601690	Electrolytic, 10μF, 16V
C246	1	1	1	DK18403020	Ceramic, 0.04μF +80%, -20%
C247	1	1	1	DK18403020	Ceramic, 0.04μF +80%, -20%
C248	1	1	1	EA10601690	Electrolytic, 10μF, 16V
C249	1	1	1	EA10701690	Electrolytic, 100μF, 16V
C250	1	1	1	EA22601690	Electrolytic, 22μF, 16V
C251	1	1	1	DK18103010	Ceramic, 0.01μF +80%, -20%
C252	1	1	1	DD15400010	Ceramic, 40pF ±5%
C253	1	1	1	DK18403020	Ceramic, 0.04μF +80%, -20%
C254	1	1	1	DD15400010	Ceramic, 40pF ±5%
C255	1	1	1	DD16201010	Ceramic, 200pF ±10%
C256	1	1	1	EV10503520	Electrolytic, 1μF ±20%, 35V
C257	1	1	1	DD16201010	Ceramic, 200pF ±10%
C258	1	1	1	DK18103010	Ceramic, 0.01μF +80%, -20%
C259	1	1	1	DK18403020	Ceramic, 0.04μF +80%, -20%
C261	1	1	1	EA10505090	Electrolytic, 1μF, 50V
C262	1	1	1	DK18104020	Ceramic, 0.1μF +80%, -20%
C263	1	1	1	DK18104020	Ceramic, 0.1μF +80%, -20%
P200 - SEMICONDUCTORS					
Q201	1	1	1	HT310472B0	Transistor, 2SC1047 C or D
Q202	1	1	1	HT310472B0	Transistor, 2SC1047 C or D
Q203	1	1	1	HT308292B0	Transistor, 2SC829 C or D
Q204	1	1	1	HT308292B0	Transistor, 2SC829 C or D
Q205	1	1	1	HT308292B0	Transistor, 2SC829 C or D
Q206	1	1	1	HT308292B0	Transistor, 2SC829 C or D
Q207	1	1	1	HT308292B0	Transistor, 2SC829 C or D
Q208	1	1	1	HT308292B0	Transistor, 2SC829 C or D
Q209	1	1	1	HT308292B0	Transistor, 2SC829 C or D
Q210	1	1	1	HT313272A0	Transistor, 2SC1327 S or T
Q211	1	1	1	HD20001210	Diode, 1S2473C
Q212	1	1	1	HD20001210	Diode, 1S2473C
Q213	1	1	1	HD20001210	Diode, 1S2473C
Q214	1	1	1	HD20001210	Diode, 1S2473C
Q215	1	1	1	HD20001210	Diode, 1S2473C
Q216	1	1	1	HD20001210	Diode, 1S2473C

U: For U.S.A.
C: For Canada
E: For Europe

REF. DESIG.	Q'TY			PART NO.	DESCRIPTION
	U	C	E		
Q217	1	1	1	HD20001210	Diode, 1S2473C
Q218	1	1	1	HD20001210	Diode, 1S2473C
Q219	1	1	1	HD10003020	Diode, 20A 90M
Q220	1	1	1	HD10003020	Diode, 20A 90M
Q221	1	1	1	HD10001050	Diode, 1N60
Q222	1	1	1	HD10001050	Diode, 1N60
Q223	1	1	1	HD10001050	Diode, 1N60
Q224	1	1	1	HD10001050	Diode, 1N60
Q225	1	1	1	HD10001050	Diode, 1N60
Q226	1	1	1	HD10001050	Diode, 1N60
Q227	1	1	1	HD10001050	Diode, 1N60
Q228	1	1	1	HD10001050	Diode, 1N60
Q229	1	1	1	HD10001050	Diode, 1N60
Q230	1	1	1	HD10001050	Diode, 1N60
Q231	1	1	1	HD10001050	Diode, 1N60
Q232	1	1	1	HD10001050	Diode, 1N60
Q233	1	1	1	HD10003020	Diode, 20A 90M
P200 - MISCELLANEOUS					
F201	1	1	1	FP11070010	Ceramic Filter, SFA 10.7MC
F202	1	1	1	FP11070010	Ceramic Filter, SFA 10.7MC
F203	1	1	1	FP11070010	Ceramic Filter, SFA 10.7MC
F204	1	1	1	FP11070010	Ceramic Filter, SFA 10.7MC
F205	1	1	1	FP11070010	Ceramic Filter, SFA 10.7MC
F206	1	1	1	FP11070010	Ceramic Filter, SFA 10.7MC
F207	1	1	1	FP11070010	Ceramic Filter, SFA 10.7MC
F208	1	1	1	FP11070010	Ceramic Filter, SFA 10.7MC
L201	1	1	1	LI14016230	IFT, FM Detector
L202	1	1	1	LC13320020	Choke Coil, 3.3μH
J201					
J211	11	11	11	YP10001200	Plug
G201	1	1	1	BF22300060	Printed Comp., 1kΩ +0.022μF
G202	1	1	1	BF10200020	Printed Comp., 100kΩ +1000pF
G204	1	1	1	BF20100040	Printed Comp., 2.7kΩ +200pF
G205	1	1	1	BF20100040	Printed Comp., 2.7kΩ +200pF
G206	1	1	1	BF20100040	Printed Comp., 2.7kΩ +200pF
G207	1	1	1	BF20100040	Printed Comp., 2.7kΩ +200pF
MULTIPLEX CIRCUIT BOARD - P300					
P300	1	1	1	YD28900033	P.W. Board, Multiplex
	1	1		ZZ22141033	P.W. Board Assembly
			1	ZZ22148030	P.W. Board Assembly
P300 - RESISTORS					
R301	1	1	1	RA02020110	Trimming, 2kΩ (B)
R302	1	1	1	RT05224140	Fixed, 220kΩ ±5%, ¼W
R303	1	1	1	RT05563140	Fixed, 56kΩ ±5%, ¼W
R304	1	1	1	RT05683140	Fixed, 68kΩ ±5%, ¼W
R305	1	1	1	RT05101140	Fixed, 100kΩ ±5%, ¼W
R306	1	1	1	RT05184140	Fixed, 180kΩ ±5%, ¼W
R307	1	1	1	RT05224140	Fixed, 220kΩ ±5%, ¼W
R308	1	1	1	RT05124140	Fixed, 120kΩ ±5%, ¼W
R309	1	1	1	RT05104140	Fixed, 100kΩ ±5%, ¼W
R310	1	1	1	RT05682140	Fixed, 6.8kΩ ±5%, ¼W
R311	1	1	1	RA04720050	Trimming, 4.7kΩ (B)
R312	1	1	1	RT05163140	Fixed, 16kΩ ±5%, ¼W
R313	1	1	1	RT05102140	Fixed, 1kΩ ±5%, ¼W
R314	1	1	1	RT05203140	Fixed, 20kΩ ±5%, ¼W
R315	1	1	1	RT05102140	Fixed, 1kΩ ±5%, ¼W

REF. DESIG.	Q'TY			PART NO.	DESCRIPTION
	U	C	E		
R316	1	1	1	RT05102140	Fixed, 1kΩ ±5%, ¼W
R317	1	1	1	RT05392140	Fixed, 3.9kΩ ±5%, ¼W
R318	1	1	1	RT05392140	Fixed, 3.9kΩ ±5%, ¼W
R319	1	1	1	RT05224140	Fixed, 220kΩ ±5%, ¼W
R320	1	1	1	RT05223140	Fixed, 22kΩ ±5%, ¼W
R321	1	1	1	RT05101140	Fixed, 100Ω ±5%, ¼W
R322	1	1	1	RT05100140	Fixed, 10Ω ±5%, ¼W
R323	1	1	1	RT05224140	Fixed, 220kΩ ±5%, ¼W
R324	1	1	1	RT05224140	Fixed, 220kΩ ±5%, ¼W
R325	1	1	1	RT05303140	Fixed, 30kΩ ±5%, ¼W
R326	1	1	1	RT05303140	Fixed, 30kΩ ±5%, ¼W
R327	1	1	1	RT05104140	Fixed, 100kΩ ±5%, ¼W
R328	1	1	1	RT05104140	Fixed, 100kΩ ±5%, ¼W
R329	1	1	1	RT05155140	Fixed, 1.5MΩ ±5%, ¼W
R330	1	1	1	RT05155140	Fixed, 1.5MΩ ±5%, ¼W
R331	1	1	1	RT05561140	Fixed, 560Ω ±5%, ¼W
R332	1	1	1	RT05561140	Fixed, 560Ω ±5%, ¼W
R333	1	1	1	RT05223140	Fixed, 22kΩ ±5%, ¼W
R334	1	1	1	RT05223140	Fixed, 22kΩ ±5%, ¼W
R335	1	1	1	RT05101140	Fixed, 100Ω ±5%, ¼W
R336	1	1	1	RT05101140	Fixed, 100Ω ±5%, ¼W
R337	1	1	1	RT05822140	Fixed, 8.2kΩ ±5%, ¼W
R338	1	1	1	RT05822140	Fixed, 8.2kΩ ±5%, ¼W
R339	1	1	1	RT05471140	Fixed, 470Ω ±5%, ¼W
R340	1	1	1	RT05471140	Fixed, 470Ω ±5%, ¼W
R341	1	1	1	RT05224140	Fixed, 220kΩ ±5%, ¼W
R342	1	1	1	RT05224140	Fixed, 220kΩ ±5%, ¼W
R343	1	1	1	RT05392140	Fixed, 3.9kΩ ±5%, ¼W
R344	1	1	1	RT05564140	Fixed, 560kΩ ±5%, ¼W
R345	1	1	1	RT05153140	Fixed, 15kΩ ±5%, ¼W
R346	1	1	1	RT05124140	Fixed, 120kΩ ±5%, ¼W
R347	1	1	1	RT05101140	Fixed, 100Ω ±5%, ¼W
R348	1	1	1	RT05224140	Fixed, 220kΩ ±5%, ¼W
R349	1	1	1	RT05562140	Fixed, 5.6kΩ ±5%, ¼W
R350	1	1	1	RT05103140	Fixed, 10kΩ ±5%, ¼W
R351	1	1	1	RT05101140	Fixed, 100Ω ±5%, ¼W
R352	1	1	1	RT05333140	Fixed, 33kΩ ±5%, ¼W
R353	1	1	1	RT05101140	Fixed, 100Ω ±5%, ¼W
R354	1	1	1	RT05104140	Fixed, 100kΩ ±5%, ¼W
R355	1	1	1	RT05273140	Fixed, 27kΩ ±5%, ¼W
R356	1	1	1	RT05104140	Fixed, 100kΩ ±5%, ¼W
R357	1	1	1	RT05102140	Fixed, 1kΩ ±5%, ¼W
R358	1	1	1	RT05101140	Fixed, 100Ω ±5%, ¼W
R359	1	1	1	RT05273140	Fixed, 27kΩ ±5%, ¼W
R360	1	1	1	RT05333140	Fixed, 33kΩ ±5%, ¼W
R361	1	1	1	RT05104140	Fixed, 100kΩ ±5%, ¼W
R362	1	1	1	RA01040180	Trimming, 100kΩ (B)
R363	1	1	1	RA01030250	Trimming, 10kΩ (B)
R364	1	1	1	RT05222140	Fixed, 2.2kΩ ±5%, ¼W
R365	1	1	1	RT05101140	Fixed, 100Ω ±5%, ¼W
R366	1	1	1	RT05103140	Fixed, 10kΩ ±5%, ¼W
R367	1	1	1	RT05101140	Fixed, 100Ω ±5%, ¼W
R368	1	1	1	RT05274140	Fixed, 270kΩ ±5%, ¼W
R369	1	1	1	RT05103140	Fixed, 10kΩ ±5%, ¼W
R370	1	1	1	RT05123140	Fixed, 12kΩ ±5%, ¼W
R371	1	1	1	RT05221140	Fixed, 220Ω ±5%, ¼W
R373	1	1	1	RT05823140	Fixed, 82kΩ ±5%, ¼W
R374	1	1	1	RA01030250	Trimming, 10kΩ (B)
R375	1	1	1	RT05101140	Fixed, 100Ω ±5%, ¼W
R376	1	1	1	RT05104140	Fixed, 100kΩ ±5%, ¼W
R377	1	1	1	RT05104140	Fixed, 100kΩ ±5%, ¼W
R378	1	1	1	RT05562140	Fixed, 5.6kΩ ±5%, ¼W
R379	1	1	1	RT05332140	Fixed, 3.3kΩ ±5%, ¼W

U : For U.S.A.
 C : For Canada
 E : For Europe

REF. DESIG.	Q'TY			PART NO.	DESCRIPTION
	U	C	E		
R380	1	1	1	RT05272140	Fixed, 2.7kΩ ±5%, ¼W
P300 - CAPACITORS					
C301	1	1	1	DF16332050	Film, 3300pF ±10%
C302	1	1	1	EA33601090	Electrolytic, 33μF, 10V
C303	1	1	1	DF17223050	Film, 0.022μF ±20%
C304	1	1	1	EA22601690	Electrolytic, 22μF, 16V
C305	1	1	1	DF55471010	Film, 470pF ±5%
C306	1	1	1	EA22601690	Electrolytic, 22μF, 16V
C307	1	1	1	EQ47405010	Electrolytic, 0.47μF ±20%, 50V
C308	1	1	1	EQ22405010	Electrolytic, 0.22μF ±20%, 50V
C309	1	1	1	EQ22405010	Electrolytic, 0.22μF ±20%, 50V
C310	1	1	1	DF17473010	Film, 0.047μF ±20%
C311	1	1	1	DF15152050	Film, 1500pF ±5%
C312	1	1	1	DF15152050	Film, 1500pF ±5%
C313	1	1	1	DD15361010	Ceramic, 360pF ±5%
C314	1	1	1	DD15361010	Ceramic, 360pF ±5%
C315	1	1	1	DF15332050	Film, 3300pF ±5%
C316	1	1	1	DF15332050	Film, 3300pF ±5%
C317	1	1	1	DF15152050	Film, 1500pF ±5%
C318	1	1	1	DF15152050	Film, 1500pF ±5%
C319	1	1	1	DF15222050	Film, 2200pF ±5%
C320	1	1	1	DF15222050	Film, 2200pF ±5%
C321	1	1	1	DF15102050	Film, 1000pF ±5%
C322	1	1	1	DF15102050	Film, 1000pF ±5%
C321	1	1	1	DF65202010	Film, 200pF ±5%
C322	1	1	1	DF65202010	Film, 200pF ±5%
C323	1	1	1	EV22403510	Electrolytic, 0.22μF ±20%, 35V
C324	1	1	1	EV22403510	Electrolytic, 0.22μF ±20%, 35V
C325	1	1	1	EV10503520	Electrolytic, 1μF ±20%, 35V
C326	1	1	1	EV10503520	Electrolytic, 1μF ±20%, 35V
C327	1	1	1	EA22702590	Electrolytic, 220μF, 25V
C328	1	1	1	EA22701690	Electrolytic, 220μF, 16V
C329	1	1	1	EA10601690	Electrolytic, 10μF, 16V
C330	1	1	1	DK18403020	Ceramic, 0.04μF +80%, -20%
C331	1	1	1	EA10505090	Electrolytic, 1μF, 50V
C332	1	1	1	EA10601690	Electrolytic, 10μF, 16V
C333	1	1	1	DD12100010	Ceramic, 10pF ±10%
C334	1	1	1	DF16683010	Film, 0.068μF ±10%
C335	1	1	1	DF17403010	Film, 0.04μF ±20%
C336	1	1	1	DK18104020	Ceramic, 0.1μF +80%, -20%
C337	1	1	1	EA47503590	Electrolytic, 4.7μF, 35V
C338	1	1	1	EA10505090	Electrolytic, 1μF, 50V
C339	1	1	1	DK18403020	Ceramic, 0.04μF +80%, -20%
C340	1	1	1	DK18403020	Ceramic, 0.04μF +80%, -20%
C341	1	1	1	DK18403020	Ceramic, 0.04μF +80%, -20%
C343	1	1	1	DF17104020	Film, 0.1μF ±20%
C344	1	1	1	DK18203020	Ceramic, 0.02μF +80%, -20%
P300 - MISCELLANEOUS					
L301	1	1	1	LS10290040	MPX Coil, 56 mH
L302	1	1	1	LS10290040	MPX Coil, 56 mH
L303	1	1	1	LS10290050	MPX Coil, 43 mH
L304	1	1	1	LS10290050	MPX Coil, 43 mH
L305	1	1	1	LC21050010	Choke Coil, 1 mH
P311	1	1	1	75061251P0	Jumper Wire
J301	22	22	22	YP10001130	Plug
J322					
P300 - SEMICONDUCTORS					
H301	1	1	1	HF200301C0	FET, 2SK30Y
H302	1	1	1	HT308281D0	Transistor, 2SC828S
H303	1	1	1	HT308281D0	Transistor, 2SC828S
H304	1	1	1	HT307322A0	Transistor, 2SC732B or G

REF. DESIG.	Q'TY			PART NO.	DESCRIPTION
	U	C	E		
H305	1	1	1	HT307322A0	Transistor, 2SC732B or G
H306	1	1	1	HT108422A0	Transistor, 2SA842 (Gr, BI)
H307	1	1	1	HT108422A0	Transistor, 2SA842 (Gr, BI)
H308	1	1	1	HT308281D0	Transistor, 2SC828S
H309	1	1	1	HT308281D0	Transistor, 2SC828S
H310	1	1	1	HT308281D0	Transistor, 2SC828S
H311	1	1	1	HT308281D0	Transistor, 2SC828S
H312	1	1	1	HF200300A0	FET, 2SK30A
H313	1	1	1	HT308281D0	Transistor, 2SC828S
H314	1	1	1	HT308281D0	Transistor, 2SC828S
H315	1	1	1	HT308281D0	Transistor, 2SC828S
H316	1	1	1	HT308281D0	Transistor, 2SC828S
H317	1	1	1	HT308281D0	Transistor, 2SC828S
H318	1	1	1	HD10001050	Diode, 1N60
H319	1	1	1	HD10001050	Diode, 1N60
H321	1	1	1	HC10004010	IC, HA1156
PHONO AMP. CIRCUIT BOARD - P400					
P400	1	1	1	YD28920084	P.W. Board, Phono Amp.
	1	1	1	ZZ22141084	P.W. Board Assembly
P400 - RESISTORS					
R401	1	1	1	RT05513140	Fixed, 51kΩ ±5%, ¼W
R402	1	1	1	RT05513140	Fixed, 51kΩ ±5%, ¼W
R403	1	1	1	RT05471140	Fixed, 470Ω ±5%, ¼W
R404	1	1	1	RT05471140	Fixed, 470Ω ±5%, ¼W
R405	1	1	1	RN05333140	Fixed, 33kΩ ±5%, ¼W
R406	1	1	1	RN05105140	Fixed, 1MΩ ±5%, ¼W
R407	1	1	1	RN05105140	Fixed, 1MΩ ±5%, ¼W
R408	1	1	1	RA01040150	Trimming, 100kΩ ±30% (B)
R409	1	1	1	RA01040150	Trimming, 100kΩ ±30% (B)
R410	1	1	1	RN05273140	Fixed, 27kΩ ±5%, ¼W
R411	1	1	1	RN05273140	Fixed, 27kΩ ±5%, ¼W
R412	1	1	1	RT05621140	Fixed, 620Ω ±5%, ¼W
R413	1	1	1	RT05621140	Fixed, 620Ω ±5%, ¼W
R414	1	1	1	RT05225140	Fixed, 2.2MΩ ±5%, ¼W
R415	1	1	1	RT05225140	Fixed, 2.2MΩ ±5%, ¼W
R416	1	1	1	RN05225140	Fixed, 2.2MΩ ±5%, ¼W
R417	1	1	1	RN05225140	Fixed, 2.2MΩ ±5%, ¼W
R418	1	1	1	RN05274140	Fixed, 270kΩ ±5%, ¼W
R419	1	1	1	RN05274140	Fixed, 270kΩ ±5%, ¼W
R420	1	1	1	RT05473140	Fixed, 47kΩ ±5%, ¼W
R421	1	1	1	RT05473140	Fixed, 47kΩ ±5%, ¼W
R422	1	1	1	RT05222140	Fixed, 2.2kΩ ±5%, ¼W
R423	1	1	1	RT05222140	Fixed, 2.2kΩ ±5%, ¼W
R424	1	1	1	RN05684140	Fixed, 680kΩ ±5%, ¼W
R425	1	1	1	RN05684140	Fixed, 680kΩ ±5%, ¼W
R426	1	1	1	RN05104140	Fixed, 100kΩ ±5%, ¼W
R427	1	1	1	RN05104140	Fixed, 100kΩ ±5%, ¼W
R428	1	1	1	RN05473140	Fixed, 47kΩ ±5%, ¼W
R429	1	1	1	RN05473140	Fixed, 47kΩ ±5%, ¼W
R430	1	1	1	RT05470140	Fixed, 47Ω ±5%, ¼W
R431	1	1	1	RT05470140	Fixed, 47Ω ±5%, ¼W
R432	1	1	1	RN05332140	Fixed, 3.3kΩ ±5%, ¼W
R433	1	1	1	RN05332140	Fixed, 3.3kΩ ±5%, ¼W
R434	1	1	1	RT05101140	Fixed, 100Ω ±5%, ¼W
R435	1	1	1	RT05470140	Fixed, 47Ω ±5%, ¼W
R436	1	1	1	RT05470140	Fixed, 47Ω ±5%, ¼W
P400 - CAPACITORS					
C420	1	1	1	DD15101020	Ceramic, 100pF ±5%
C421	1	1	1	DD15101020	Ceramic, 100pF ±5%

U : For U.S.A.
C : For Canada
E : For Europe

REF. DESIG.	Q'TY			PART NO.	DESCRIPTION
	U	C	E		
C401	1	1	1	EV33502560	Electrolytic, 3.3μF ±20%, 25V
C402	1	1	1	EV33502560	Electrolytic, 3.3μF ±20%, 25V
C403	1	1	1	EE47601640	Electrolytic, 47μF ±20%, 16V
C404	1	1	1	EE47601640	Electrolytic, 47μF ±20%, 16V
C405	1	1	1	DD15400040	Ceramic, 40pF ±5%, 50V
C406	1	1	1	DD15400040	Ceramic, 40pF ±5%, 50V
C407	1	1	1	DD11040010	Ceramic, 4pF ±0.5pF, 50V
C408	1	1	1	DD11040010	Ceramic, 4pF ±0.5pF, 50V
C409	1	1	1	DF65562010	Film, 5600pF ±5%, 50V
C410	1	1	1	DF65562010	Film, 5600pF ±5%, 50V
C411	1	1	1	DF65162010	Film, 1600pF ±5%, 50V
C412	1	1	1	DF65162010	Film, 1600pF ±5%, 50V
C413	1	1	1	ED10703510	Electrolytic, 100μF, 35V
C414	1	1	1	DF16105500	Film, 1μF ±10%, 100V
C415	1	1	1	DF16105500	Film, 1μF ±10%, 100V
C416	1	1	1	DD16500010	Ceramic, 50pF ±10%
C417	1	1	1	DD16500010	Ceramic, 50pF ±10%
C418	1	1	1	DD12100010	Ceramic, 10pF ±1pF, 50V
C419	1	1	1	DD12100010	Ceramic, 10pF ±1pF, 50V
P400 - SEMICONDUCTORS & PLUGS					
H401	1	1	1	HT313441E0	Transistor, 2SC1344 E
H402	1	1	1	HT313441E0	Transistor, 2SC1344 E
H403	1	1	1	HT313442A0	Transistor, 2SC1344 D or E
H404	1	1	1	HT313442A0	Transistor, 2SC1344 D or E
H405	1	1	1	HT317752C0	Transistor, 2SC1775A C or D
H406	1	1	1	HT317752C0	Transistor, 2SC1775A C or D
H407	1	1	1	HD20001210	Varistor, 1S-2473C
H408	1	1	1	HD20001210	Varistor, 1S-2473C
H409	1	1	1	HV00002060	Varistor, VD1212
J401	?	8	8	YP10001130	Plug
J408	?	8	8	YP10001130	Plug
DOLBY FM CIRCUIT BOARD - P600					
P600	1	1	1	YA22140210	P.W. Board, Dolby FM
	1	1	1	ZZ22140210	P.W. Board Assembly
P600 - RESISTORS					
R601	1	1	1	RT05623141	Fixed, 62kΩ ±5%, ¼W
R602	1	1	1	RT05623141	Fixed, 62kΩ ±5%, ¼W
R603	1	1	1	RA05020200	Trimming, 5kΩ (B)
R604	1	1	1	RA05020200	Trimming, 5kΩ (B)
R605	1	1	1	RT05104141	Fixed, 100kΩ ±5%, ¼W
R606	1	1	1	RT05104141	Fixed, 100kΩ ±5%, ¼W
R607	1	1	1	RT05332141	Fixed, 3.3kΩ ±5%, ¼W
R608	1	1	1	RT05332141	Fixed, 3.3kΩ ±5%, ¼W
R609	1	1	1	RT05473141	Fixed, 47kΩ ±5%, ¼W
R610	1	1	1	RT05473141	Fixed, 47kΩ ±5%, ¼W
R611	1	1	1	RT05181141	Fixed, 180Ω ±5%, ¼W
R612	1	1	1	RT05181141	Fixed, 180Ω ±5%, ¼W
R613	1	1	1	RT05103141	Fixed, 10kΩ ±5%, ¼W
R614	1	1	1	RT05103141	Fixed, 10kΩ ±5%, ¼W
R615	1	1	1	RT05102141	Fixed, 1kΩ ±5%, ¼W
R616	1	1	1	RT05102141	Fixed, 1kΩ ±5%, ¼W
R617	1	1	1	RT05274141	Fixed, 270kΩ ±5%, ¼W
R618	1	1	1	RT05274141	Fixed, 270kΩ ±5%, ¼W
R619	1	1	1	RT05684141	Fixed, 680kΩ ±5%, ¼W
R620	1	1	1	RT05684141	Fixed, 680kΩ ±5%, ¼W
R621	1	1	1	RT05154141	Fixed, 150kΩ ±5%, ¼W

REF. DESIG.	Q'TY			PART NO.	DESCRIPTION
	U	C	E		
R622	1	1	1	RT05154141	Fixed, 150kΩ ±5%, ¼W
R623	1	1	1	RT05104141	Fixed, 100kΩ ±5%, ¼W
R624	1	1	1	RT05104141	Fixed, 100kΩ ±5%, ¼W
R625	1	1	1	RT05121141	Fixed, 120Ω ±5%, ¼W
R626	1	1	1	RT05121141	Fixed, 120Ω ±5%, ¼W
R627	1	1	1	RT05102141	Fixed, 1kΩ ±5%, ¼W
R628	1	1	1	RT05102141	Fixed, 1kΩ ±5%, ¼W
R629	1	1	1	RT05101141	Fixed, 100Ω ±5%, ¼W
R630	1	1	1	RT05101141	Fixed, 100Ω ±5%, ¼W
R631	1	1	1	RT05101141	Fixed, 100Ω ±5%, ¼W
P600 - CAPACITORS					
C601	1	1	1	DF15562050	Film, 5600pF ±5%
C602	1	1	1	DF15562050	Film, 5600pF ±5%
C603	1	1	1	DD15201010	Ceramic, 200pF ±5%
C604	1	1	1	DD15201010	Ceramic, 200pF ±5%
C605	1	1	1	DF15273010	Film, 0.027μF ±5%
C606	1	1	1	DF15273010	Film, 0.027μF ±5%
C607	1	1	1	EA22701690	Electrolytic, 220μF, 16V
C608	1	1	1	EA22701690	Electrolytic, 220μF, 16V
C609	1	1	1	EA10601690	Electrolytic, 10μF, 16V
C610	1	1	1	EA10601690	Electrolytic, 10μF, 16V
C611	1	1	1	EE10505010	Electrolytic, 1μF, 50V
C612	1	1	1	EE10505010	Electrolytic, 1μF, 50V
C613	1	1	1	EA10601690	Electrolytic, 10μF, 16V
C614	1	1	1	EA10601690	Electrolytic, 10μF, 16V
C615	1	1	1	EA10601690	Electrolytic, 10μF, 16V
C616	1	1	1	EA10601690	Electrolytic, 10μF, 16V
C617	1	1	1	EA10601690	Electrolytic, 10μF, 16V
C618	1	1	1	EA10601690	Electrolytic, 10μF, 16V
C619	1	1	1	DF15104050	Film, 0.1μF ±5%
C620	1	1	1	DF15104050	Film, 0.1μF ±5%
C621	1	1	1	DF15473010	Film, 0.047μF ±5%
C622	1	1	1	DF15473010	Film, 0.047μF ±5%
C623	1	1	1	DF15334050	Film, 0.33μF ±5%
C624	1	1	1	DF15334050	Film, 0.33μF ±5%
C625	1	1	1	DF15472010	Film, 0.0047μF ±5%
C626	1	1	1	DF15472010	Film, 0.0047μF ±5%
P600 - MISCELLANEOUS					
Q601	1	1	1	HC10002270	IC, NE545B
Q602	1	1	1	HC10002270	IC, NE545B
Q603	1	1	1	HD10003020	Diode, 20A90
Q604	1	1	1	HD10003020	Diode, 20A90
J601	?	6	6	YP10001130	Plug
J606	?	6	6	YP10001130	Plug
P611	1	1	1	75061251P0	Jumper Wire
MAIN AMP. CIRCUIT BOARD - P700					
P700	2	2	2	YD29652012	P.W. Board, Main Amp.
	2	2	2	ZZ22142012	P.W. Board Assembly
P700 - RESISTORS					
R701	2	2	2	RT05102141	Fixed, 1kΩ ±5%, ¼W
R702	2	2	2	RT05474141	Fixed, 470kΩ ±5%, ¼W
R703	2	2	2	RT05513141	Fixed, 51kΩ ±5%, ¼W
R704	2	2	2	RT05103141	Fixed, 10kΩ ±5%, ¼W
R705	2	2	2	RT05103141	Fixed, 10kΩ ±5%, ¼W
R706	2	2	2	RT05681141	Fixed, 680Ω ±5%, ¼W
R707	2	2	2	RT05751141	Fixed, 750Ω ±5%, ¼W

U : For U.S.A.
C : For Canada
E : For Europe

REF. DESIG.	Q'TY			PART NO.	DESCRIPTION
	U	C	E		
R708	2	2	2	RT05181141	Fixed, 180Ω ±5%, ¼W
R709	2	2	2	RT05153141	Fixed, 15kΩ ±5%, ¼W
R710	2	2	2	RT05224141	Fixed, 220kΩ ±5%, ¼W
R711	2	2	2	RT05272141	Fixed, 2.7kΩ ±5%, ¼W
R712	2	2	2	RT05183141	Fixed, 18kΩ ±5%, ¼W
R713	2	2	2	RT05183141	Fixed, 18kΩ ±5%, ¼W
R714	2	2	2	RT05821141	Fixed, 820Ω ±5%, ¼W
R715	2	2	2	RT05821141	Fixed, 820Ω ±5%, ¼W
R716	2	2	2	RT05821141	Fixed, 820Ω ±5%, ¼W
R717	2	2	2	RT05821141	Fixed, 820Ω ±5%, ¼W
R718	2	2	2	GF05151140	Fixed, 150Ω ±5%, ¼W
R719	2	2	2	GF05151140	Fixed, 150Ω ±5%, ¼W
R720	2	2	2	RT05101141	Fixed, 100Ω ±5%, ¼W
R721	2	2	2	RT05151141	Fixed, 150Ω ±5%, ¼W
R722	2	2	2	RT05151141	Fixed, 150Ω ±5%, ¼W
R723	2	2	2	RT05623141	Fixed, 62kΩ ±5%, ¼W
R724	2	2	2	GJ05100030	Fixed, 10Ω ±5%, 3W
R725	2	2	2	GJ05222010	Fixed, 2.2kΩ ±5%, 1W
R726	2	2	2	RA02020130	Trimming, 2kΩ (B)
R727	2	2	2	RA01020200	Trimming, 1kΩ (B)
R728	2	2	2	GJ05022010	Fixed, 2.2Ω ±5%, 1W
R729	2	2	2	GJ05022010	Fixed, 2.2Ω ±5%, 1W
R730	2	2	2	RT05510141	Fixed, 51Ω ±5%, ¼W
R731	2	2	2	RT05820141	Fixed, 82Ω ±5%, ¼W
R732	2	2	2	RT05241141	Fixed, 240Ω ±5%, ¼W
R733	2	2	2	RT05331141	Fixed, 330Ω ±5%, ¼W
R734	2	2	2	RT05271141	Fixed, 270Ω ±5%, ¼W
R735	2	2	2	RT05331141	Fixed, 330Ω ±5%, ¼W
R736	2	2	2	RT05123141	Fixed, 12kΩ ±5%, ¼W
R737	2	2	2	RT05183141	Fixed, 18kΩ ±5%, ¼W
R738	2	2	2	RT05113141	Fixed, 11kΩ ±5%, ¼W
R739	2	2	2	GF05221120	Fixed, 220Ω ±5%, ½W
R740	2	2	2	GJ05022020	Fixed, 2.2Ω ±5%, 2W
R741	2	2	2	RT05100140	Fixed, 10Ω ±5%, ¼W
R742	2	2	2	RT05100140	Fixed, 10Ω ±5%, ¼W
R743	2	2	2	GW10272050	Fixed, 0.27Ω ±10%, 5W
R744	2	2	2	GW10272050	Fixed, 0.27Ω ±10%, 5W
R745	2	2	2	GW10272050	Fixed, 0.27Ω ±10%, 5W
R746	2	2	2	GW10272050	Fixed, 0.27Ω ±10%, 5W
P700 - CAPACITORS					
C721	2	2	2	DK16221510	Ceramic, 220pF ±10%
C701	2	2	2	EE22505040	Electrolytic, 2.2μF, 50V
C702	2	2	2	DD15101010	Ceramic, 100pF ±5%
C703	2	2	2	DK16221510	Ceramic, 220pF ±10%
C704	2	2	2	EA10603590	Electrolytic, 10μF, 35V
C705	2	2	2	EE10701640	Electrolytic, 100μF, 16V
C706	2	2	2	DF17104050	Film, 0.1μF ±20%
C707	2	2	2	DD15100500	Ceramic, 10pF ±0.25pF, 500V
C708	2	2	2	DK16501500	Ceramic, 500pF ±10%
C709	2	2	2	DF17104520	Film, 0.1μF ±20%, 200V
C710	2	2	2	EQ10505010	Electrolytic, 1μF, 50V
C711	2	2	2	EQ10505010	Electrolytic, 1μF, 50V
C712	2	2	2	EA10601690	Electrolytic, 10μF, 16V
C713	2	2	2	EA10601690	Electrolytic, 10μF, 16V
C714	2	2	2	DF16104500	Film, 0.1μF ±10%, 100V
C715	2	2	2	DF16104500	Film, 0.1μF ±10%, 100V
C716	2	2	2	DF16104500	Film, 0.1μF ±10%, 100V
C717	2	2	2	DF16104500	Film, 0.1μF ±10%, 100V
C718	2	2	2	DK16331500	Ceramic, 330pF ±10%
C719	2	2	2	DK16331500	Ceramic, 330pF ±10%
C720	2	2	2	DK16221510	Ceramic, 220pF ±10%

REF. DESIG.	Q'TY			PART NO.	DESCRIPTION
	U	C	E		
P700 - SEMICONDUCTORS					
Q701	2	2	2	HT317752E0	Transistor, 2SC1775A E or F
Q702	2	2	2	HT317752E0	Transistor, 2SC1775A E or F
Q703	2	2	2	HT317752D0	Transistor, 2SC1775A D or E
Q704	2	2	2	HT109122C0	Transistor, 2SA912 R or S
Q705	2	2	2	HT109122C0	Transistor, 2SA912 R or S
Q706	2	2	2	HT109142B0	Transistor, 2SA914 R or S
Q707	2	2	2	HT319532B0	Transistor, 2SC1953 R or S
Q708	2	2	2	HT315682B0	Transistor, 2SC1568 R or S
Q709	2	2	2	HT108392O0	Transistor, 2SA839 O or Y
Q710	2	2	2	HT316692O0	Transistor, 2SC1669 O or Y
Q711	2	2	2	HV00005080	Diode, STV3HY
Q712	2	2	2	HD30039090	Diode, WZ-240 (24D)
Q713	2	2	2	HD20011050	Diode, 1S1555
Q714	2	2	2	HD20011050	Diode, 1S1555
Q715	2	2	2	HD20011050	Diode, 1S1555
Q716	2	2	2	HD20011050	Diode, 1S1555
Q717	2	2	2	HD20011050	Diode, 1S1555
Q718	2	2	2	HD20011050	Diode, 1S1555
Q719	2	2	2	HD20011050	Diode, 1S1555
Q720	2	2	2	HD20011050	Diode, 1S1555
Q721	2	2	2	HD20011050	Diode, 1S1555
Q724	2	2	2	HT309452A0	Transistor, 2SC945 Q or R
Q725	2	2	2	HT107332B0	Transistor, 2SA733 Q or R
Q726	2	2	2	HD20011010	Diode, W06C
Q727	2	2	2	HD20011010	Diode, W06C
Q728	2	2	2	HD20011050	Diode, 1S1555
P700 - MISCELLANEOUS					
J701	2	2	2	YP06001040	Plug, 3P
J702	2	2	2	YP06000520	Plug, 4P
J704					
J720	17	17	17	YP10001130	Plug
L701	2	2	2	LC22220010	Choke Coil, 2.2μH
P709	24	24	24	2933118010	Spacer, R724, R740, R743~R746
P707	32	32	32	3444118050	Spacer, R725, R739, R741, R728, R729, R742, R718, R719
P711	8	8	8	75061251P0	Jumper Wire, 12.5mm
POWER SUPPLY CIRCUIT BOARD - P800					
P800	1	1	1	YD29180044	P.W. Board, Power Supply
	1	1	1	ZZ22141044	P.W. Board Assembly
P800 - RESISTORS					
R801	1	1	1	GQ10151050	Fixed, 150Ω ±10%, 5W
R802	1	1	1	GF05332140	Fixed, 3.3kΩ ±5%, ¼W
R803	1	1	1	GF05100140	Fixed, 10Ω ±5%, ¼W
R804	1	1	1	GF05100120	Fixed, 10Ω ±5%, ¼W
R805	1	1	1	RT05472140	Fixed, 4.7kΩ ±5%, ¼W
R806	1	1	1	RT05472140	Fixed, 4.7kΩ ±5%, ¼W
R807	1	1	1	GF05392140	Fixed, 3.9kΩ ±5%, ¼W
R808	1	1	1	RT05223140	Fixed, 22kΩ ±5%, ¼W
R809	1	1	1	RA05020200	Trimming, 5kΩ (B)
R810	1	1	1	RT05562140	Fixed, 5.6kΩ ±5%, ¼W
R811	1	1	1	GJ05271020	Fixed, 270Ω ±5%, 2W
R812	1	1	1	RT05472140	Fixed, 4.7kΩ ±5%, ¼W
R813	1	1	1	RT05273140	Fixed, 27kΩ ±5%, ¼W

U: For U.S.A.
C: For Canada
E: For Europe

REF. DESIG.	Q'TY			PART NO.	DESCRIPTION
	U	C	E		
R814	1	1	1	RT05393140	Fixed, 39kΩ ±5%, ¼W
R815	1	1	1	RT05393140	Fixed, 39kΩ ±5%, ¼W
R816	1	1	1	RT05394140	Fixed, 390kΩ ±5%, ¼W
R817	1	1	1	GJ05471010	Fixed, 470Ω ±5%, 1W
R819	1	1	1	GU05562120	Fixed, 5.6kΩ ±5%, ¼W
R820	1	1	1	GU05562120	Fixed, 5.6kΩ ±5%, ¼W
P800 - CAPACITORS					
C801	1	1	1	DK18103510	Ceramic, 0.01μF +100%, -0%, 500V
C802	1	1	1	DK18103510	Ceramic, 0.01μF +100%, -0%, 500V
C803	1	1	1	EA47706310	Electrolytic, 470μF, 63V
C804	1	1	1	EA22706310	Electrolytic, 220μF, 63V
C805	1	1	1	EA47701690	Electrolytic, 470μF, 16V
C806	1	1	1	EA22706310	Electrolytic, 220μF, 63V
C807	1	1	1	EA33705090	Electrolytic, 330μF, 50V
C808	1	1	1	DF17473050	Film, 0.047μF, 50V
C809	1	1	1	EA10605090	Electrolytic, 10μF, 50V
C810	1	1	1	DF17103050	Film, 0.01μF, 50V
C811	1	1	1	EA10606390	Electrolytic, 10μF, 63V
C812	1	1	1	EA47601690	Electrolytic, 47μF, 16V
C813	1	1	1	EA33701090	Electrolytic, 330μF, 10V
P800 - SEMICONDUCTORS					
H801	1	1	1	HT403314A0	Transistor, 2SD331 C,D,E or P
H802	1	1	1	HT403314A0	Transistor, 2SD331 C,D,E or P
H803	1	1	1	HT307343A0	Transistor, 2SC734 R, O or Y
H804	1	1	1	HT309452A0	Transistor, 2SC945 Q or R
H805	1	1	1	HT309452A0	Transistor, 2SC945 Q or R
H806	1	1	1	HT313183A0	Transistor, 2SC1318 P, Q or R
H807	1	1	1	HT313183A0	Transistor, 2SC1318 P, Q or R
H808	1	1	1	HD20011030	Diode, DS-131B
H809	1	1	1	HD20011030	Diode, DS-131B
H810	1	1	1	HD30027090	Diode, WZ-140
H811	1	1	1	HD30023090	Diode, WZ-071
H812	1	1	1	HD20003210	Diode, 1S2471 (BLK)
P800 - MISCELLANEOUS					
L801	1	1	1	LY20240110	Relay, 24V, 10A
F801	1	1	1	FS10020060	Fuse, 0.2A (UL)
J801	?	11	11	YP10001130	Plug
J811	1	1	1	YJ08000210	Socket, Fuse Holder
J812	1	1	1	YJ08000210	Socket, Fuse Holder
J813	1	1	1	YP10001130	Plug
J814	1	1	1	YP10001130	Plug
J815	1	1	1	YP10001130	Plug
P808	4	4	4	2933118020	Spacer, R804, R811
P809	2	2	2	2933118010	Spacer, R801
PRE & TONE AMP. CIRCUIT BOARD - PE01					
PE01	1	1	1	YD29180022	P.W. Board, Pre & Tone Amp.
	1	1	1	ZZ22141022	P.W. Board Assembly
PE01 - RESISTORS					
RE01	1	1	1	RM05030610	Variable, 50kΩ (B)
RE02	1	1	1	RD02040010	Variable, 200kΩ (B)
RE03	1	1	1	RD02040010	Variable, 200kΩ (B)
RE04	1	1	1	RD02040010	Variable, 200kΩ (B)
RE05	1	1	1	RT05223140	Fixed, 22kΩ ±5%, ¼W

REF. DESIG.	Q'TY			PART NO.	DESCRIPTION
	U	C	E		
RE06	1	1	1	RT05223140	Fixed, 22kΩ ±5%, ¼W
RE07	1	1	1	RT05392140	Fixed, 3.9kΩ ±5%, ¼W
RE08	1	1	1	RT05392140	Fixed, 3.9kΩ ±5%, ¼W
RE09	1	1	1	RT05391140	Fixed, 390Ω ±5%, ¼W
RE10	1	1	1	RT05391140	Fixed, 390Ω ±5%, ¼W
RE11	1	1	1	RN05154140	Fixed, 150kΩ ±5%, ¼W
RE12	1	1	1	RN05154140	Fixed, 150kΩ ±5%, ¼W
RE13	1	1	1	RN05474140	Fixed, 470kΩ ±5%, ¼W
RE14	1	1	1	RN05474140	Fixed, 470kΩ ±5%, ¼W
RE15	1	1	1	RT02911140	Fixed, 910Ω ±2%, ¼W
RE16	1	1	1	RT02911140	Fixed, 910Ω ±2%, ¼W
RE17	1	1	1	RT05822140	Fixed, 8.2kΩ ±5%, ¼W
RE18	1	1	1	RT05822140	Fixed, 8.2kΩ ±5%, ¼W
RE19	1	1	1	RT05224140	Fixed, 220kΩ ±5%, ¼W
RE20	1	1	1	RT05224140	Fixed, 220kΩ ±5%, ¼W
RE21	1	1	1	RC00000120	Fixed, 0Ω, ¼W
RE22	1	1	1	RC00000120	Fixed, 0Ω, ¼W
RE23	1	1	1	RT05273140	Fixed, 27kΩ ±5%, ¼W
RE24	1	1	1	RT05273140	Fixed, 27kΩ ±5%, ¼W
RE25	1	1	1	RT05273140	Fixed, 27kΩ ±5%, ¼W
RE26	1	1	1	RT05273140	Fixed, 27kΩ ±5%, ¼W
RE29	1	1	1	RT05273140	Fixed, 27kΩ ±5%, ¼W
RE30	1	1	1	RT05273140	Fixed, 27kΩ ±5%, ¼W
RE31	1	1	1	RT05203140	Fixed, 20kΩ ±5%, ¼W
RE32	1	1	1	RT05203140	Fixed, 20kΩ ±5%, ¼W
RE33	1	1	1	RT05103140	Fixed, 10kΩ ±5%, ¼W
RE34	1	1	1	RT05103140	Fixed, 10kΩ ±5%, ¼W
RE35	1	1	1	RT05103140	Fixed, 10kΩ ±5%, ¼W
RE36	1	1	1	RT05103140	Fixed, 10kΩ ±5%, ¼W
RE37	1	1	1	RT05103140	Fixed, 10kΩ ±5%, ¼W
RE38	1	1	1	RT05103140	Fixed, 10kΩ ±5%, ¼W
RE39	1	1	1	RT05103140	Fixed, 10kΩ ±5%, ¼W
RE40	1	1	1	RT05103140	Fixed, 10kΩ ±5%, ¼W
RE41	1	1	1	RT05684140	Fixed, 680kΩ ±5%, ¼W
RE42	1	1	1	RT05684140	Fixed, 680kΩ ±5%, ¼W
RE43	1	1	1	RC00000120	Fixed, 0Ω, ¼W
RE44	1	1	1	RC00000120	Fixed, 0Ω, ¼W
RE45	1	1	1	RT05225140	Fixed, 2.2MΩ ±5%, ¼W
RE46	1	1	1	RT05225140	Fixed, 2.2MΩ ±5%, ¼W
RE47	1	1	1	RT05225140	Fixed, 2.2MΩ ±5%, ¼W
RE48	1	1	1	RT05225140	Fixed, 2.2MΩ ±5%, ¼W
RE49	1	1	1	RT05225140	Fixed, 2.2MΩ ±5%, ¼W
RE50	1	1	1	RT05225140	Fixed, 2.2MΩ ±5%, ¼W
RE51	1	1	1	RT02103140	Fixed, 10kΩ ±2%, ¼W
RE52	1	1	1	RT02103140	Fixed, 10kΩ ±2%, ¼W
RE53	1	1	1	RT02103140	Fixed, 10kΩ ±2%, ¼W
RE54	1	1	1	RT02103140	Fixed, 10kΩ ±2%, ¼W
RE55	1	1	1	RT02103140	Fixed, 10kΩ ±2%, ¼W
RE56	1	1	1	RT02103140	Fixed, 10kΩ ±2%, ¼W
RE57	1	1	1	RC00000120	Fixed, 0Ω, ¼W
RE58	1	1	1	RC00000120	Fixed, 0Ω, ¼W
RE61	1	1	1	RT05272140	Fixed, 2.7kΩ ±5%, ¼W
RE62	1	1	1	RT05104140	Fixed, 100kΩ ±5%, ¼W
RE63	1	1	1	RT05474140	Fixed, 470kΩ ±5%, ¼W
RE64	1	1	1	RT05474140	Fixed, 470kΩ ±5%, ¼W
RE65	1	1	1	RT05473140	Fixed, 47kΩ ±5%, ¼W
RE66	1	1	1	RT05473140	Fixed, 47kΩ ±5%, ¼W
RE67	1	1	1	RT05221140	Fixed, 220Ω ±5%, ¼W
RE68	1	1	1	RT05221140	Fixed, 220Ω ±5%, ¼W
RE69	1	1	1	RT05103140	Fixed, 10kΩ ±5%, ¼W
RE70	1	1	1	RT05103140	Fixed, 10kΩ ±5%, ¼W
RE71	1	1	1	RT05104140	Fixed, 100kΩ ±5%, ¼W
RE72	1	1	1	RT05104140	Fixed, 100kΩ ±5%, ¼W

U: For U.S.A.
C: For Canada
E: For Europe

REF. DESIG.	Q'TY			PART NO.	DESCRIPTION
	U	C	E		
RE73	1	1	1	RT05101140	Fixed, 100Ω ±5%, ¼W
RE74	1	1	1	RC00000120	Fixed, 0Ω, ¼W
PE01 - CAPACITORS					
CE01	1	1	1	DK16681010	Ceramic, 680pF ±10%, 50V
CE02	1	1	1	DK16681010	Ceramic, 680pF ±10%, 50V
CE03	1	1	1	DF16104050	Film, 0.1µF ±10%, 50V
CE04	1	1	1	DF16104050	Film, 0.1µF ±10%, 50V
CE05	1	1	1	DF17105520	Film, 1µF ±20%, 250V
CE06	1	1	1	DF17105520	Film, 1µF ±20%, 250V
CE07	1	1	1	DD15300010	Ceramic, 30pF ±5%, 50V
CE08	1	1	1	DD15300010	Ceramic, 30pF ±5%, 50V
CE09	1	1	1	EA10701090	Electrolytic, 100µF +50%, -10%, 10V
CE10	1	1	1	EA10701090	Electrolytic, 100µF +50%, -10%, 10V
CE11	1	1	1	EA10603590	Electrolytic, 10µF +50%, -10%, 35V
CE12	1	1	1	EA10603590	Electrolytic, 10µF +50%, -10%, 35V
CE13	1	1	1	EV33503560	Electrolytic, 3.3µF±20%, 35V
CE14	1	1	1	EV33503560	Electrolytic, 3.3µF±20%, 35V
CE15	1	1	1	DF15103050	Film, 0.01µF±5%, 50V
CE16	1	1	1	DF15103050	Film, 0.01µF±5%, 50V
CE17	1	1	1	DF15103050	Film, 0.01µF±5%, 50V
CE18	1	1	1	DF15103050	Film, 0.01µF±5%, 50V
CE19	1	1	1	DF15393010	Film, 0.039µF±5%, 50V
CE20	1	1	1	DF15393010	Film, 0.039µF±5%, 50V
CE21	1	1	1	DF15393010	Film, 0.039µF±5%, 50V
CE22	1	1	1	DF15393010	Film, 0.039µF±5%, 50V
CE23	1	1	1	DF16682050	Film, 0.068µF±5%, 50V
CE24	1	1	1	DF16682050	Film, 0.068µF±5%, 50V
CE25	1	1	1	DF65271510	Film, 270pF ±5%, 50V
CE26	1	1	1	DF65271510	Film, 270pF ±5%, 50V
CE27	1	1	1	DF15102050	Film, 0.001µF±5%, 50V
CE28	1	1	1	DF15102050	Film, 0.001µF±5%, 50V
CE29	1	1	1	DF16332050	Film, 0.0033µF±5%, 50V
CE30	1	1	1	DF16332050	Film, 0.0033µF±5%, 50V
CE31	1	1	1	DD16500010	Ceramic, 50pF ±5%, 50V
CE32	1	1	1	DD16500010	Ceramic, 50pF ±5%, 50V
CE33	1	1	1	EV10502560	Electrolytic, 1µF ±20%, 25V
CE34	1	1	1	EV10502560	Electrolytic, 1µF ±20%, 25V
CE35	1	1	1	EV33503560	Electrolytic, 3.3µF±20%, 25V
CE36	1	1	1	EV33503560	Electrolytic, 3.3µF±20%, 25V
CE37	1	1	1	EQ47501610	Electrolytic, 4.7µF±30%, 16V
CE38	1	1	1	EQ47501610	Electrolytic, 4.7µF±30%, 16V
CE39	1	1	1	EA22703590	Electrolytic, 220µF +50%, -10%, 35V
PE01 - MISCELLANEOUS					
HE01	1	1	1	HC10001210	IC, BA312
HE02	1	1	1	HC10001210	IC, BA312
HE03	1	1	1	HT313272A0	Transistor, 2SC1327 S or T
HE04	1	1	1	HT107212A0	Transistor, 2SA721 S or T
HE05	1	1	1	HT313272A0	Transistor, 2SC1327 S or T
HE06	1	1	1	HT107212A0	Transistor, 2SA721 S or T
JE01	1	1	1	YP06000260	Plug, 14P
SE01	1	1	1	SR10050073	Rotary Switch, Tone Mode
BUFFER AMP. CIRCUIT BOARD - PH01					
PH01	1	1	1	YD29180030	P.W. Board, Buffer Amp.

REF. DESIG.	Q'TY			PART NO.	DESCRIPTION
	U	C	E		
	1	1	1	ZZ29180030	P.W. Board Assembly
PH01 - RESISTORS					
RH01	1	1	1	RT05622140	Fixed, 6.2kΩ ±5%, ¼W
RH02	1	1	1	RT05682140	Fixed, 6.8kΩ ±5%, ¼W
RH03	1	1	1	RT05124140	Fixed, 120kΩ ±5%, ¼W
RH04	1	1	1	RT05124140	Fixed, 120kΩ ±5%, ¼W
RH05	1	1	1	RT05124140	Fixed, 120kΩ ±5%, ¼W
RH06	1	1	1	RT05124140	Fixed, 120kΩ ±5%, ¼W
RH07	1	1	1	RN05185140	Fixed, 1.8MΩ ±5%, ¼W
RH08	1	1	1	RN05185140	Fixed, 1.8MΩ ±5%, ¼W
RH09	1	1	1	RN05185140	Fixed, 1.8MΩ ±5%, ¼W
RH10	1	1	1	RN05185140	Fixed, 1.8MΩ ±5%, ¼W
RH11	1	1	1	RN05153140	Fixed, 15kΩ ±5%, ¼W
RH12	1	1	1	RN05153140	Fixed, 15kΩ ±5%, ¼W
RH13	1	1	1	RN05153140	Fixed, 15kΩ ±5%, ¼W
RH14	1	1	1	RN05153140	Fixed, 15kΩ ±5%, ¼W
RH15	1	1	1	RT05750140	Fixed, 75Ω ±5%, ¼W
RH16	1	1	1	RT05750140	Fixed, 75Ω ±5%, ¼W
RH17	1	1	1	RT05472140	Fixed, 4.7kΩ ±5%, ¼W
RH18	1	1	1	RT05472140	Fixed, 4.7kΩ ±5%, ¼W
RH19	1	1	1	RT05363140	Fixed, 36kΩ ±5%, ¼W
RH20	1	1	1	RT05224140	Fixed, 220kΩ ±5%, ¼W
RH21	1	1	1	RT05224140	Fixed, 220kΩ ±5%, ¼W
RH22	1	1	1	RT05224140	Fixed, 220kΩ ±5%, ¼W
RH23	1	1	1	RT05224140	Fixed, 220kΩ ±5%, ¼W
RH24	1	1	1	RT05750140	Fixed, 75Ω ±5%, ¼W
RH25	1	1	1	RT05750140	Fixed, 75Ω ±5%, ¼W
RH26	1	1	1	RT05750140	Fixed, 75Ω ±5%, ¼W
RH27	1	1	1	RT05750140	Fixed, 75Ω ±5%, ¼W
RH28	1	1	1	RT05101140	Fixed, 100Ω ±5%, ¼W
PH01 - CAPACITORS					
CH01	1	1	1	DF17224050	Film, 0.22µF±20%, 50V
CH02	1	1	1	DF17224050	Film, 0.22µF±20%, 50V
CH03	1	1	1	DF17224050	Film, 0.22µF±20%, 50V
CH04	1	1	1	DF17224050	Film, 0.22µF±20%, 50V
CH05	1	1	1	EE47505040	Electrolytic, 4.7µF±20%, 50V
CH06	1	1	1	EE47505040	Electrolytic, 4.7µF±20%, 50V
CH07	1	1	1	EE47505040	Electrolytic, 4.7µF±20%, 50V
CH08	1	1	1	EE47505040	Electrolytic, 4.7µF±20%, 50V
CH09	1	1	1	DK17502010	Ceramic, 500pF ±20%, 50V
CH10	1	1	1	DK17502010	Ceramic, 500pF ±20%, 50V
CH11	1	1	1	DK17502010	Ceramic, 500pF ±20%, 50V
CH12	1	1	1	DK17502010	Ceramic, 500pF ±20%, 50V
CH13	1	1	1	EA22703590	Electrolytic, 220µF, 35V
PH01 - SEMICONDUCTORS & PLUGS					
HH01	1	1	1	HT313452A0	Transistor, 2SC1345 D or E
HH02	1	1	1	HT313452A0	Transistor, 2SC1345 D or E
HH03	1	1	1	HT313452A0	Transistor, 2SC1345 D or E
HH04	1	1	1	HT313452A0	Transistor, 2SC1345 D or E
HH05	1	1	1	HT107202A0	Transistor, 2SA720 R or S
HH06	1	1	1	HT107202A0	Transistor, 2SA720 R or S
HH07	1	1	1	HT107202A0	Transistor, 2SA720 R or S
HH08	1	1	1	HT107202A0	Transistor, 2SA720 R or S
HH09	1	1	1	HT313182Q0	Transistor, 2SC1318 B or R
HH10	1	1	1	HT313182Q0	Transistor, 2SC1318 Q or R
HH11	1	1	1	HV00006060	Varistor, VD1222
BUFFER AMP. CIRCUIT BOARD - PH01					
JH01	10	10	10	YP10001130	Plug
JH10					

U : For U.S.A.
C : For Canada
E : For Europe

REF. DESIG.	Q'TY			PART NO.	DESCRIPTION
	U	C	E		
PY01	1	1	1	YD29180080 ZZ29180080	FUNCTION LAMP CIRCUIT BOARD - PY01 P.W. Board, Function Lamp P.W. Board Assembly
MY01 ? MY08	8	8	8	IN10080370	PY01 - LAMPS & PLUGS Lamp, 8V, 40mA
JY01 ? JY12	12	12	12	YP10001130	Plug
PZ01	1	1	1	YD28920010 ZZ29182010	DIAL LAMP CIRCUIT BOARD - PZ01 P.W. Board, Dial Lamp P.W. Board Assembly
MZ01 ? MZ06	6	6	6	IN10080070	PZ01 - LAMPS, SOCKETS & PLUGS Lamp
JZ01 ? JZ12 JZ13 JZ14 JZ17 JZ18	12	12	12	YJ08000170	Socket
PU01	1	1	1	YA22140310 ZZ22140310	HI/LOW FILTER, LOUDNESS & SPEAKER SWITCHES CIRCUIT BOARD - PU01 P.W. Board, Hi/Low Filter, Loudness & Speaker Switches P.W. Board Assembly
RU01 RU02 RU03 RU04 RU05 RU06 RU07 RU08 RU09 RU10 RU11 RU12 RU13 RU14 RU15 RU16 RU17 RU18 RU19 RU20	1	1	1	GD05114141 GD05114141 GD05274141 GD05274140 GD05225140 GD05225141 GD05113141 GD05113140 GD05113141 GD05113141 GD05113141 GD05113141 GD05113141 GD05225141 GD05225141 GD05104141 GD05104141 GD05104141 GD05104141 GD05104141 GD05102141 GD05102141	PU01 - RESISTORS Fixed, 110kΩ ±5%, ¼W Fixed, 110kΩ ±5%, ¼W Fixed, 270kΩ ±5%, ¼W Fixed, 270kΩ ±5%, ¼W Fixed, 2.2MΩ ±5%, ¼W Fixed, 2.2MΩ ±5%, ¼W Fixed, 11kΩ ±5%, ¼W Fixed, 11kΩ ±5%, ¼W Fixed, 11kΩ ±5%, ¼W Fixed, 11kΩ ±5%, ¼W Fixed, 11kΩ ±5%, ¼W Fixed, 11kΩ ±5%, ¼W Fixed, 11kΩ ±5%, ¼W Fixed, 2.2MΩ ±5%, ¼W Fixed, 2.2MΩ ±5%, ¼W Fixed, 100kΩ ±5%, ¼W Fixed, 100kΩ ±5%, ¼W Fixed, 100kΩ ±5%, ¼W Fixed, 100kΩ ±5%, ¼W Fixed, 100kΩ ±5%, ¼W Fixed, 1kΩ ±5%, ¼W Fixed, 1kΩ ±5%, ¼W
RU21 RU22	1	1	1	GD05682141 GD05682141	Fixed, 6.8kΩ ±5%, ¼W Fixed, 6.8kΩ ±5%, ¼W

REF. DESIG.	Q'TY			PART NO.	DESCRIPTION
	U	C	E		
RU23 RU24 RU25 RU26 RU27 RU28 RU29 RU30	1	1	1	GD05562141 GD05562141 GD05821141 GD05821141 GD05224141 GD05224141 GD05151141 GD05151141	Fixed, 5.6kΩ ±5%, ¼W Fixed, 5.6kΩ ±5%, ¼W Fixed, 820Ω ±5%, ¼W Fixed, 820Ω ±5%, ¼W Fixed, 220kΩ ±5%, ¼W Fixed, 220kΩ ±5%, ¼W Fixed, 150Ω ±5%, ¼W Fixed, 150Ω ±5%, ¼W
RU31 RU32 RU33 RU34 RU35	1	1	1	GD05102141 GQ10331030 GQ10331030 GJ05151010 GJ05151010	Fixed, 1kΩ ±5%, ¼W Fixed, 330Ω ±10%, 3W Fixed, 330Ω ±10%, 3W Fixed, 150Ω ±5%, 1W Fixed, 150Ω ±5%, 1W
CU01 CU02 CU03 CU04 CU05 CU06 CU07 CU08 CU09 CU10	1	1	1	DF15104010 DF15104010 DF15223010 DF15223010 DF15223010 DF15223010 DF15152010 DF15152010 DF15222010 DF15222010	PU01 - CAPACITORS Film, 0.1μF ±5%, 50V Film, 0.1μF ±5%, 50V Film, 0.022μF ±5%, 50V Film, 0.022μF ±5%, 50V Film, 0.022μF ±5%, 50V Film, 0.022μF ±5%, 50V Film, 0.0015μF ±5%, 50V Film, 0.0015μF ±5%, 50V Film, 0.0022μF ±5%, 50V Film, 0.0022μF ±5%, 50V
CU11 CU12 CU13 CU14 CU15 CU16 CU17 CU18 CU19 CU20	1	1	1	EE22405040 EE22405040 DD15391010 DD15391010 DD11040010 DD11040010 EE10602540 EE10602540 DD15101020 DD15101020	Electrolytic, 0.22μF, 50V Electrolytic, 0.22μF, 50V Ceramic, 390pF ±5% Ceramic, 390pF ±5% Ceramic, 4pF ±0.5pF Ceramic, 4pF ±0.5pF Electrolytic, 10μF, 25V Electrolytic, 10μF, 25V Ceramic, 100pF ±5%, 50V Ceramic, 100pF ±5%, 50V
CU21	1	1	1	EA47603590	Electrolytic, 47μF, 35V
PU07	4	4	4	3444118050	PU01 - MISCELLANEOUS Spacer, RU34, RU35
SU01	1	1	1	SP04050150	Pushswitch
QU01 QU02 QU03 QU04	1	1	1	HT107223A0 HT107223A0 HT313272A0 HT313272A0	Transistor, 2SA722 S, T or U Transistor, 2SA722 S, T or U Transistor, 2SC1327 S or T Transistor, 2SC1327 S or T
JU01 ? JU13	13	13	13	YP10001130	Plug
PT01	1	1	1	YA22140410 ZZ22140410	TAPE COPY, MPX NOISE FILTER, MULTIPATH & FM MUTING SWITCHES P.W. Board, Tape Copy, MPX Noise Filter, Multipath & FM Muting Switches P.W. Board Assembly
RT01 RT02 RT03 RT04	1	1	1	GD05203141 GD05162141 GD05222141 GD05222141	PT01 - RESISTORS Fixed, 20kΩ ±5%, ¼W Fixed, 1.6kΩ ±5%, ¼W Fixed, 2.2kΩ ±5%, ¼W Fixed, 2.2kΩ ±5%, ¼W

U : For U.S.A.
 C : For Canada
 E : For Europe

REF. DESIG.	Q'TY			PART NO.	DESCRIPTION
	U	C	E		
RT05	1	1	1	GD05104141	Fixed, 100kΩ ±5%, ¼W
RT06	1	1	1	GD05153141	Fixed, 15kΩ ±5%, ¼W
RT07	1	1	1	GD05101141	Fixed, 100Ω ±5%, ¼W
RT08	1	1	1	GD05562141	Fixed, 5.6kΩ ±5%, ¼W
PT01 - CAPACITORS					
CT01	1	1	1	EA47503590	Electrolytic, 4.7μF, 35V
CT02	1	1	1	EA10601690	Electrolytic, 10μF, 16V
CT03	1	1	1	EA47503590	Electrolytic, 4.7μF, 35V
CT04	1	1	1	EA47503590	Electrolytic, 4.7μF, 35V
CT05	1	1	1	DF15393010	Film, 0.039μF, 50V
CT06	1	1	1	EA10601690	Electrolytic, 10μF, 16V
PT01 - SEMICONDUCTORS					
QT01	1	1	1	HT308282A0	Transistor, 2SC828 R or S
QT02	1	1	1	HT308282A0	Transistor, 2SC828 R or S
QT03	1	1	1	HD10003020	Diode, 20A90
QT04	1	1	1	HD10003020	Diode, 20A90
PT01 - MISCELLANEOUS					
ST01	1	1	1	SP04050160	Pushswitch
JT01	1	1	1	YP10001130	Plug
JT02	1	1	1	YP10001130	Plug
PT11	1	1	1	75061251P0	Jumper Wire,
ANTENNA CIRCUIT BOARD - PC01					
PC01	1	1	1	YD22140010	P.W. Board, Antenna Muting
	1	1	1	ZZ22140010	P.W. Board Assembly
PC01 - MISCELLANEOUS					
RC01	1	1	1	RK02030322	Resistor, Trimming, 20kΩ (B)
RC02	1	1	1	RK05030170	Resistor, Trimming, 50kΩ (B)
LC01	1	1	1	LB30075260	Balun Coil
LC02	1	1	1	LC11540020	Choke Coil, 150μH
JC01	1	1	1	BY04050010	Terminal, 4P
JC02	6	6	6	YP10001130	Plug
JC07	6	6	6	YP10001130	Plug
PC11	1	1	1	75061251P0	Jumper Wire,
GENERAL MISCELLANEOUS					
J007	1	1	1	YJ01000980	Jack, Dubbing Out
J008	1	1	1	YJ01000810	Jack, Dubbing In
S005	1	1	1	SP01010170	Pushswitch, Power
J009	1	1	1	YJ01000980	Jack, Phone
J002	1	1	1	YT01010050	Terminal, Ground
J003	1	1	1	YT02060120	Terminal, Phono 1 & 2, Aux
J004	1	1	1	YT02080060	Terminal, Tape Monitor
J006	1	1	1	YT02010090	Terminal, FM Quadrantal Out
J010	1	1	1	YT03040160	Terminal, System 1 Speaker
J011	1	1	1	YT03040160	Terminal, System 2 Speaker
J012	1	1	1	YJ04000560	Plug, AC Outlet (Unswitched)
J013	1	1	1	YJ04000560	Plug, AC Outlet (Switched)
J014	1	1	1	YJ08000120	Socket, Fuse Holder
J014	1	1	1	YJ08000220	Socket, Fuse Holder
J003	1	1	1	YT02080080	Terminal, Phono 1 & 2, Aux

REF. DESIG.	Q'TY			PART NO.	DESCRIPTION
	U	C	E		
W001	1	1	1	YC02400220	AC Cord
W001	1	1	1	YC01900030	AC Cord
F001	1	1	1	FS10800040	Fuse, 8A (UL)
F001	1	1	1	FS10800020	Fuse, 8A
F001	1	1	1	FS10500900	Fuse, 5A
G001	1	1	1	BF10400030	Printed Comp., 0.033μF +120Ω, 125V
G001	1	1	1	BF33300020	Printed Comp., 0.033μF +120Ω, 125V
M001	1	1	1	IM11042280	DC Meter, Signal Strength/ Multipath
M002	1	1	1	IM11042240	DC Meter, FM Tuning
M004	1	1	1	IN10080070	Lamp, Meter
M005	1	1	1	IN10080070	Lamp, Meter
C010	1	1	1	EA33601090	Electrolytic, 33μF, 10V
C011	1	1	1	EA33601090	Electrolytic, 33μF, 10V
J028	1	1	1	YJ08000190	Socket, Meter Lamp
J029	1	1	1	YJ08000190	Socket, Meter Lamp
R001	1	1	1	RS05030310	Resistor, Variable, 50kΩ, Balance
L001	1	1	1	LF11200470	Antenna Coil
L002	1	1	1	LC13320020	Choke Coil, 3.3μH
C002	1	1	1	DK17103010	Capacitor, Ceramic, 0.01μF ±20%, 50V
C003	1	1	1	DK17103010	Capacitor, Ceramic, 0.01μF ±20%, 50V
C004	1	1	1	DK17103010	Capacitor, Ceramic, 0.01μF ±20%, 50V
R009	1	1	1	RC10225120	Resistor, Fixed, 2.2MΩ ±10%, ½W
L003	1	1	1	LC13320020	Choke Coil, 3.3μH
C005	1	1	1	DK17103010	Capacitor, Ceramic, 0.01μF ±20%, 50V
J016	1	1	1	YL01050110	Plug, 5P (UL)
R010	1	1	1	GJ05222030	Resistor, Fixed, 2.2kΩ ±5%, 3W
R011	1	1	1	GJ05222030	Resistor, Fixed, 2.2kΩ ±5%, 3W
J015	1	1	1	YL01050110	Plug, 5P (UL)
Q001	1	1	1	HT107472C0	Transistor, 2SA747A R or O
Q002	1	1	1	HT107472C0	Transistor, 2SA747A R or O
Q003	1	1	1	HT311162C0	Transistor, 2SC1116A R or O
Q004	1	1	1	HT311162C0	Transistor, 2SC1116A R or O
Q005	1	1	1	HT107472C0	Transistor, 2SA747A R or O
Q006	1	1	1	HT107472C0	Transistor, 2SA747A R or O
Q007	1	1	1	HT311162C0	Transistor, 2SC1116A R or O
Q008	1	1	1	HT311162C0	Transistor, 2SC1116A R or O
J020	1	1	1	YJ05000200	Socket, Transistor
J021	1	1	1	YJ05000200	Socket, Transistor
J022	1	1	1	YJ05000200	Socket, Transistor
J023	1	1	1	YJ05000200	Socket, Transistor
J024	1	1	1	YJ05000200	Socket, Transistor
J025	1	1	1	YJ05000200	Socket, Transistor
J026	1	1	1	YJ05000200	Socket, Transistor

U : For U.S.A.
 C : For Canada
 E : For Europe

REF. DESIG.	Q'TY			PART NO.	DESCRIPTION
	U	C	E		
J027	1	1	1	YJ05000200	Socket, Transistor
J030	1	1	1	YJ06001040	Jack, 3P
J031	1	1	1	YJ06001040	Jack, 3P
J032	1	1	1	BY03110010	Jack, Voltage Selector
J017	1	1	1	YJ06001180	Jack, 4P
J018	1	1	1	YJ06001190	Jack, 4P
J019	1	1	1	YJ06000610	Jack, 14P
J005	1	1	1	YT02040113	Terminal, Pre Out/Main In
C015	1	1	1	DK18104020	Capacitor, Ceramic, 0.1μF ±20%, 50V
S001	1	1	1	SR12060040	Rotary Switch, Selector
S001	1	1	1	SR12060050	Rotary Switch, Selector
S002	1	1	1	SR07030010	Rotary Switch, Tape Monitor
S003	1	1	1	SR04050070	Rotary Switch, Mode
R002	1	1	1	RT05102140	Resistor, Fixed, 1kΩ ±5%, ¼W
R003	1	1	1	RT05102140	Resistor, Fixed, 1kΩ ±5%, ¼W
R004	1	1	1	RT05151140	Resistor, Fixed, 150Ω±5%, ¼W
C013	1	1	1	DF15222050	Capacitor, Film, 2200pF ±5%, 50V
C013	1	1	1	DF15102050	Capacitor, Film, 1000pF ±5%, 50V
C014	1	1	1	DF15222050	Capacitor, Film, 2200pF ±5%, 50V
C014	1	1	1	DF15102050	Capacitor, Film, 1000pF ±5%, 50V
Q009	1	1	1	HD20016080	Diode, SG-5TS
Q010	1	1	1	HD20017080	Diode, SG-5TR
C006	1	1	1	DF17104530	Capacitor, Film, 0.1μF ±20%, 250V
C007	1	1	1	DF17104530	Capacitor, Film, 0.1μF ±20%, 250V
L004	1	1	1	TS63302170	Transformer, Power
L004	1	1	1	TS63302180	Transformer, Power
J031	1	1	1	BY03110010	Terminal, Voltage Conversion
C008	1	1	1	EC15907510	Capacitor, Electrolytic, 15000μF +50%, -10%, 75V
C009	1	1	1	EC15907510	Capacitor, Electrolytic, 15000μF +50%, -10%, 75V
S006	1	1	1	FR30100010	Thermal Protector
S007	1	1	1	FR30100010	Thermal Protector
FUSE CIRCUIT BOARD - PR01					
PR01	1	1	1	YD28920100	P.W. Board, Fuse
PR01	1	1	1	ZZ28929100	P.W. Board Assembly
PR01	1	1	1	ZZ28928100	P.W. Board Assembly
PR01 - MISCELLANEOUS					
FR01	1	1	1	FS10500900	Fuse, 5A
FR02	1	1	1	FS10150030	Fuse, 1.5A
FR03	1	1	1	FS10150030	Fuse, 1.5A
FR04	1	1	1	FS10200050	Fuse, 2A
JR01	1	1	1	YJ08000200	Jack
JR02	1	1	1	YJ08000200	Jack
JR03	1	1	1	YJ08000200	Jack
JR04	1	1	1	YJ08000200	Jack

REF. DESIG.	Q'TY			PART NO.	DESCRIPTION
	U	C	E		
JR05	1	1	1	YJ08000200	Jack
JR06	1	1	1	YJ08000200	Jack
JR07	1	1	1	YJ08000200	Jack
JR08	1	1	1	YJ08000200	Jack
JR09	1	1	1	YP10000990	Plug
JR10	1	1	1	YP10000990	Plug
JR11	1	1	1	YP10000990	Plug
JR12	1	1	1	YP10000990	Plug
JR13	1	1	1	YP10000990	Plug
JR14	1	1	1	YP10000990	Plug
JR15	1	1	1	YP10000990	Plug
JR16	1	1	1	YP10000990	Plug
FR01	1	1	1	FS10800020	Fuse, 8A
FR02	1	1	1	FS10150050	Fuse, 1.5A
FR03	1	1	1	FS10150050	Fuse, 1.5A
FR04	1	1	1	FS10200060	Fuse, 2A
JR01	1	1	1	YJ08000170	Jack
JR02	1	1	1	YJ08000170	Jack
JR03	1	1	1	YJ08000170	Jack
JR04	1	1	1	YJ08000170	Jack
JR05	1	1	1	YJ08000170	Jack
JR06	1	1	1	YJ08000170	Jack
JR07	1	1	1	YJ08000170	Jack
JR08	1	1	1	YJ08000170	Jack

13. TECHNICAL SPECIFICATIONS

AMPLIFIER SECTION:

Rated Power Output, Minimum Continuous Average Power per Channel, Both Channels Driven	130 W
Power Band	20 Hz to 20 kHz
Total Harmonic Distortion	0.07%
Load Impedance	8 ohms
Maximum Power Output, DIN 45500	
(Less than 1% THD, 10 min. test at 1 kHz)	145 W
Power Bandwidth at 1% THD, DIN 45500	10 Hz to 70 kHz
I.M. Distortion	
(I.H.F. method, 60 Hz and 7 kHz mixed 4:1 at rated power output)	0.07%
Damping Factor	60
Sensitivity (at MAIN IN)	1.5 V
Impedance (at MAIN IN)	45 kohms
Frequency Response for Power Amp Only	
(at 1 W output, 20 Hz to 20 kHz)	±0.2 dB

PREAMPLIFIER SECTION:

Phono	
Input Overload at 1 kHz	110 mV
Equivalent Input Noise	1.0 μ V
Dynamic Range	
(Dynamic Range is the ratio of input overload to equivalent input noise.)	100 dB
Input Sensitivity	1.8 mV
Input Impedance	47 kohms
Frequency Response, RIAA 20 Hz to 20 kHz	±0.5 dB
Signal-to-Noise Ratio	
(at rated output and 7.75 mV input)	78 dB
Signal-to-Noise Ratio, unweighted (DIN 45500)	47 dB
High Level (Aux and Tape)	
Input Sensitivity	180 mV
Input Impedance	100 kohms
Frequency Response	
(includes power amp)	10 Hz to 60 kHz, ±1.0 dB
Signal-to-Noise Ratio	
(ref. to rated output and 775 mV input)	90 dB
Output Levels	
Tape Out (ref. 7.75 mV at Phono inputs)	775 mV
Pre-Out (ref. 180 mV at Aux inputs)	1.5 V
(ref. 500 mV at Aux inputs, main amp disconnected)	4.2 V
Output Impedance	
Tape Out	600 ohms
Pre-Out	900 ohms

FM TUNER SECTION:

Sensitivity	
IHF Usable	10.3 dBf (1.8 μ V)
IHF 50 dB Quieting (Mono)	16.1 dBf (3.5 μ V)
(Stereo)	36 dBf (35 μ V)
DIN Sensitivity (Mono, 26 dB S/N, 300 ohms input)	1.6 μ V
(Stereo, 46 dB S/N, 300 ohms input)	80 μ V
Quieting Slope (Mono)	
RF Input for 30 dB Quieting	9.8 dBf (1.7 μ V)
Quieting at:	
20 dBf (5.5 μ V)	58 dB
25 dBf (10 μ V)	63 dB
40 dBf (55 μ V)	72 dB
65 dBf (1000 μ V)	78 dB

Quieting Slope (Stereo)	
Quieting at:	
30 dBf (17 μ V)	42 dB
40 dBf (55 μ V)	52 dB
50 dBf (173 μ V)	60 dB
65 dBf (1000 μ V)	67 dB
Distortion (Mono)	
at 50 dB Quieting, 1000 Hz	0.6%
at 65 dBf (1000 μ V), 1000 Hz	0.15%
Distortion (Stereo)	
at 50 dB Quieting, 1000 Hz	0.6%
at 65 dBf (1000 μ V), 1000 Hz	0.3%
Hum and Noise	
at 65 dBf (1000 μ V)	
Mono	75 dB
Stereo	65 dB
Frequency Response	
30 Hz to 15 kHz	
Mono	\pm 1.0 dB
Stereo	\pm 1.0 dB
Capture Ratio	
at 45 dBf (100 μ V)	1.5 dB
at 65 dBf (1000 μ V)	1.0 dB
Alternate Channel Selectivity	80 dB
Spurious Response Rejection	100 dB
Image Response Rejection	85 dB
I.F. Rejection (Balanced)	100 dB
A.M. Suppression	57 dB
Stereo Separation	
100 Hz	42 dB
1000 Hz	45 dB
10 kHz	32 dB
Subcarrier Rejection	65 dB

AM TUNER SECTION:

IHF Usable Sensitivity	10 μ V
Distortion (THD), 30% Modulation	0.4%
Signal-to-Noise Ratio	54 dB
Frequency Response (\pm 3 dB)	40 Hz to 2.5 kHz
Alternate Channel Selectivity	46 dB
Image Rejection	80 dB
Spurious Response Rejection	90 dB
I.F. Rejection	75 dB

GENERAL:

Power Requirements	120 V AC, 50/60 Hz (U.S.A. and Canadian Versions) 220 V AC, 50/60 Hz (European Version)
	(This unit can be converted by a qualified technician to operate on 110/120/240 V AC, 50/60 Hz.)
Power Consumption at rated output, both channels operating	540 W
Idling Power (Volume Control at zero)	65 W
Semiconductor Complement:	
Integrated Circuits	4
Transistors	96
Diodes	55
Field Effect Transistors	2
Dimensions:	
Panel Width	491 mm (19-1/4 inches)
Panel Height	146 mm (5-3/4 inches)
Depth	386 mm (15-1/4 inches)
Weight:	
Unit alone	22.5 kg (49.5 lbs)
Packed for shipment	26 kg (57.2 lbs)