

HiFi Service Manuals

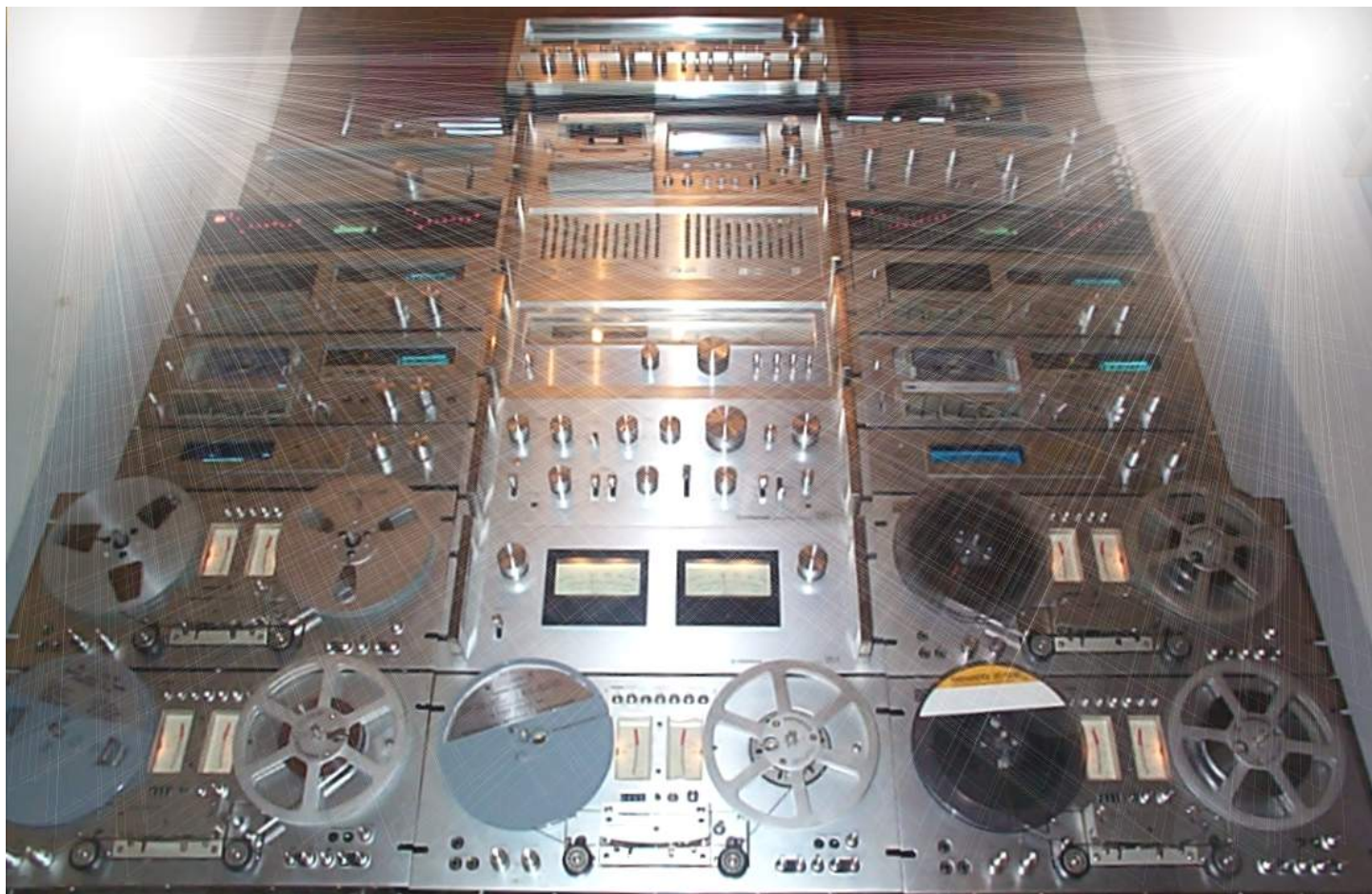

© HiFi Service Manuals. Unauthorized use Prohibited. Property of www.HiFiServiceManuals.com & HiFiServiceManuals on Ebay.

348

**SERVICE
MANUAL 2385**

marantz

model 2385

Stereophonic Receiver

TABLE OF CONTENTS

Section	Title	Page
1.	P.W. BOARDS	1
2.	TEST EQUIPMENT REQUIRED FOR SERVICING	2
3.	AM ALIGNMENT PROCEDURES	2
3.1	AM IF Alignment	2
3.2	AM Frequency Range and Tracking Alignment	2
3.3	AM Signal Strength Meter Alignment	2
4.	FM ALIGNMENT PROCEDURES	2
4.1	FM Frequency Range and Tracking Alignment	2
4.2	Stereo Separation Alignment	3
4.3	Muting Circuit Alignment	3
4.4	Dolby FM Tape Output Setting	4
5.	AUDIO ADJUSTMENT	4
6.	VOLTAGE CONVERSION FOR EUROPEAN MODEL	4
7.	DIAGRAMS	6
7.1	Block Diagram	6
7.2	Connection Diagram - U.S.A. & Canada	8
7.3	Connection Diagram - Europe	10
8.	SCHEMATIC DIAGRAMS AND COMPONENT LOCATIONS	12
8.1	FM Front End Circuit Board P100	12
8.2	AM Tuner, FM IF & MPX Stereo Decoder Circuit Board P200	13
8.3	FM Noise Amp Circuit Board PB00	16
8.4	FM Buffer Amp Circuit Board PC00	16
8.5	Phono Amp & Selector Switch Circuit Board P400	17
8.6	Power Supply Circuit Board P850	18
8.7	Main Amp & Peak Indicator Circuit Board P700	19
8.8	Pre & Tone Amp Circuit Board PE00	22
8.9	Dolby NR Socket Circuit Board PK00	24
8.10	Audio Muting Circuit Board PN00	24
8.11	Soft Start Circuit Board PQ00	24
8.12	Tape Copy, Tape Monitor, MPX Noise Filter & Multipath Switches Circuit Board PS00	25
8.13	Dubbing In & Out Jacks Circuit Board PV00	25
8.14	Filter Amp Circuit Board PT00	26
8.15	Speaker System Switch & Attenuator Circuit Board PW00	26
8.16	Peak & Function Indicator LED Circuit Board PY00	27
8.17	Dial Lamp Circuit Board PZ00	27
9.	MAJOR COMPONENT LOCATIONS	28
9.1	Cabinet - Front View - U.S.A. & Canada	28
9.2	Chassis - Top View - U.S.A. & Canada	28
9.3	Cabinet - Rear View - U.S.A. & Canada	29
9.4	Chassis - Bottom View - U.S.A. & Canada	29
9.5	Cabinet - Front View - Europe	30
9.6	Chassis - Top View - Europe	30
9.7	Cabinet - Rear View - Europe	31
9.8	Chassis - Bottom View - Europe	31
10.	EXPLODED VIEWS	32
10.1	Front Panel Exploded View	32
10.2	Chassis Exploded View	34
10.3	Rear Panel Exploded View - Europe	36
10.4	Packing Material Exploded View	37

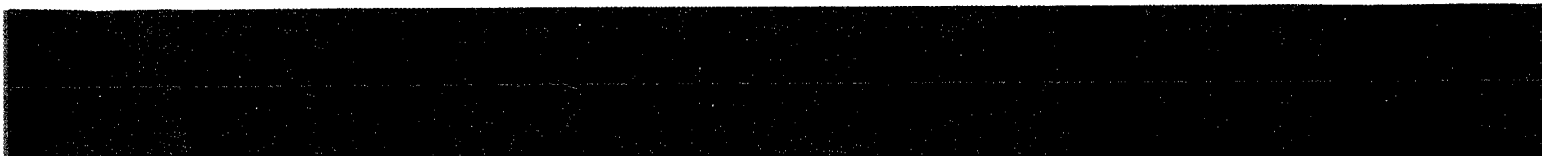

11. PARTS LIST	38
12. TECHNICAL SPECIFICATIONS	53
13. SCHEMATIC DIAGRAMS	55

INTRODUCTION

This service manual was prepared for use by Authorized Warranty Stations and contains service information for Marantz Model 2385 Stereophonic Receiver.

Servicing information and voltage data included in this manual are intended for use by the knowledgeable and experienced technician only. All instructions should be read carefully. No attempt should be made to proceed without a good understanding of the operation of the receiver.

The parts list furnishes information by which replacement parts may be ordered from the Marantz Company. A simple description is included for parts which can usually be obtained through local suppliers.

1. P.W. BOARDS

As can be seen from the circuit diagram the chassis of Model 2385 consists of the following units. Each unit mounted on a printed circuit board is described within the square enclosed by a bold dotted line on the circuit diagram.

1. FM Front End mounted on P.W. Board P100
2. AM Tuner, FM IF & MPX Stereo Decoder mounted on P.W. Board P200
3. FM Noise Amp mounted on P.W. Board PB00
4. FM Buffer Amp mounted on P.W. Board PC00
5. Phono Amp & Selector Switch mounted on P.W. Board P400
6. Main Amp & Peak Indicator mounted on P.W. Board P700
7. Power Supply mounted on P.W. Board P850
8. Pre & Tone Amp mounted on P.W. Board PE00
9. Dolby NR Socket mounted on P.W. Board PK00
10. Audio Muting mounted on P.W. Board PN00
11. Soft Start mounted on P.W. Board PQ00
12. Tape Copy, Tape Monitor, MPX Noise Filter & Multipath Switches mounted on P.W. Board PS00
13. Filter Amp mounted on P.W. Board PT00
14. Dubbing In & Out Jacks mounted on P.W. Board PV00
15. Speaker System Switch & Attenuator mounted on P.W. Board PW00
16. Peak & Function Indicator LED mounted on P.W. Board PY00
17. Dial Lamp mounted on P.W. Board PZ00

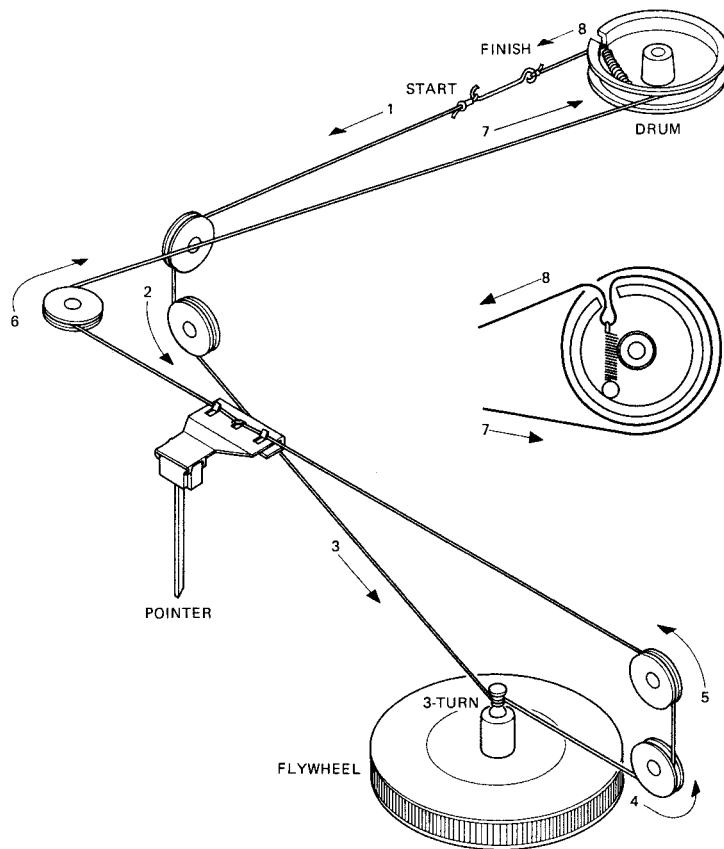

Figure 1. Dial Stringing

2. TEST EQUIPMENT REQUIRED FOR SERVICING

This table lists the test equipment required for servicing the Model 2385 Receiver.

Item	Manufacturer and Model No.	Use
AM Signal Generator		Signal source for AM alignment
Test Loop		Use with AM Signal Generator
FM Signal Generator MPX Signal Generator	Sound Technology Model 1000A	Signal source for FM alignment Stereo separation alignment and trouble shooting
Distortion Analyzer Audio Oscillator AC VTVM	Sound Technology Model 1700A	Distortion measurements Sinewave and squarewave signal source Voltage measurements (AC)
Oscilloscope	Tektronix Model T932 Philips Model 3232	Waveform analysis and trouble shooting and ASO alignment
Frequency Counter	Fluke Model 1900A	MPX Oscillator adjustment (VCO)
Circuit Tester		Trouble shooting
DC VTVM	Fluke Model 8000 "Digital" Simpson Model 313, Triplet Model 801	Voltage measurements (DC)
AC Wattmeter	Simpson Model 1379	Monitors primary power to amplifier
AC Ammeter	Commercial Grade (1-10A)	Monitors amplifier output under short circuit condition
Line Voltmeter	Simpson Model 1359	Monitors potential of primary power to amplifier
Variable Autotransformer	Superior Electronic Co., Powerstat Model 116B-10A	Adjusts level of primary power to amplifier
Shorting Plug	Use phono plug with 600-ohm across center pin and shell	Shorts amplifier input to eliminate noise pickup
Output Load (8 ohms, 0.5%, 200 W)	Commercial Grade	Provides 8-ohm load for amplifier output termination
Output Load (4 ohms, 0.5%, 300 W)	Commercial Grade	Provides 4-ohm load for amplifier output termination

3. AM ALIGNMENT PROCEDURES

3.1 AM IF ALIGNMENT

1. Connect a sweep generator to the J229 and an alignment scope to the test point B.
2. Rotate each core of IF transformers L153 and L154 for maximum height and flat top symmetrical response.

3.2 AM FREQUENCY RANGE AND TRACKING ALIGNMENT

1. Set AM signal generator to 515 kHz. Turn the tuning capacitor fully closed (place the tuning pointer at the low end) and adjust the oscillator coil L152 for maximum audio output.
2. Set the signal generator to 1650 kHz. Place the tuning pointer in the high frequency and adjust the oscillator trimmer on the oscillator tuning capacitor for maximum audio output.
3. Repeat steps 1 and 2 until no further adjustment is necessary.
4. Set the generator to 600 kHz and tune the receiver to the same frequency and adjust a slug core of AM ferrite-rod antenna L002 and RF coil L151 for maximum output.

5. Set the generator to 1400 kHz and tune the receiver to the same frequency and adjust both trimming capacitors of antenna and RF tuned circuit for maximum output.
6. Repeat steps 4 and 5 until no further adjustment is necessary.

NOTE: During tracking alignment reduce the signal generator output as necessary to avoid AGC action.

3.3 AM SIGNAL STRENGTH METER ALIGNMENT

Set an AM signal generator to 1000 kHz at $5\ \mu\text{V}$, and adjust R163 so that the signal strength meter may read 80% of the full scale.

4. FM ALIGNMENT PROCEDURES

4.1 FM FREQUENCY RANGE AND TRACKING ALIGNMENT

1. Connect an FM signal generator to the FM ANTENNA terminals and an oscilloscope and an audio distortion analyzer to the TAPE MONITOR OUT jacks on the rear panel.

2. Set the signal generator to 87.4 MHz and provide about 3 to 5 μV . Place the tuning pointer at the low frequency end by rotating the tuning knob and adjust the core of oscillator coil L106 to obtain maximum audio output.
3. Set the signal generator to 109 MHz and provide about 3 to 5 μV output. Rotate the tuning knob and place the tuning pointer at the high frequency end and adjust the trimming capacitor C123 for maximum output.
4. Repeat steps 2 and 3 until no further adjustment is necessary.
5. Set the signal generator to 90 MHz and tune the receiver to the same frequency. Decrease signal generator output until the audio output level decreases with the decreasing generator output. Adjust the antenna coil L101, RF coils L102, L103 and L104 and IF transformer L105 for minimum audio distortion.
6. Set the signal generator to 106 MHz and tune the receiver to the same frequency. Adjust the trimming capacitors CF01, CF02, CF03 and CF04 for minimum distortion.
7. Repeat steps 5 and 6 until no further adjustment is necessary.
8. Adjust the secondary core (upper) of discriminator transformer L201 so that the center tuning meter pointer indicates its center at no signal applied. Set the FM signal generator to 98 MHz and increase its output level 1 μV and tune the receiver to the same frequency so that the center tuning meter pointer indicates its center. Adjust the primary core (lower) of L201 for minimum distortion.

9. Set the signal generator to 98 MHz at 1000 μV , and adjust R278 so that the signal strength meter may read 90% of the full scale.

4.2 STEREO SEPARATION ALIGNMENT

1. Set the FM signal generator to provide 1 μV at 98 MHz. Tune the receiver to the same frequency so that the center tuning meter pointer indicates its center.
2. Turn the signal generator modulation off (with the pilot signal turned off), connect a frequency counter to test point J238, and adjust R310 so that the frequency counter may precisely read 19 kHz.
3. Modulate the signal generator with stereo composite signal consisting only of subchannel signal (of course a pilot signal must be included).
4. Adjust the trimming resistor R319 for maximum and same separation in both channels.

4.3 MUTING CIRCUIT ALIGNMENT

1. Set the FM signal generator to provide 6 μV at 98 MHz and tune the receiver to the same frequency correctly.
2. Depress the FM MUTING pushswitch. Set R001 to MIN position (counterclockwise). Adjust R330 until the muting circuit is activated to produce output for exactly 6 μV input.
3. In turn increase the FM signal generator output up to 50 μV .
4. Set R001 to MAX position (clockwise). Adjust R347 until the muting circuit is activated to produce output for exactly 50 μV input.

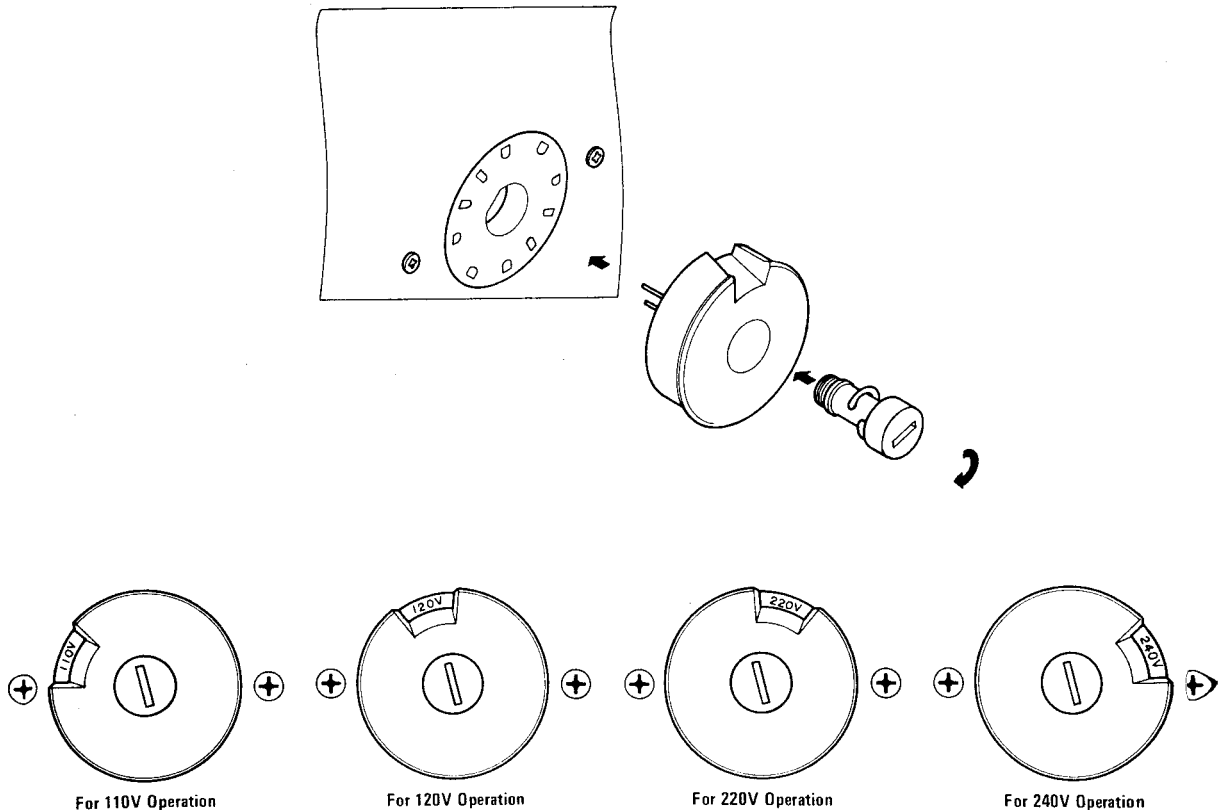

Figure 2. Voltage Conversion Chart

5. Turn R001 from MIN to MAX to assure the muting threshold level can change in the range of 6 to 50 μ V.

4.4 DOLBY FM TAPE OUTPUT SETTING

1. Set the modulation of FM signal generator to 400 Hz, 50% (± 37.5 kHz Dev.).
2. Set the signal generator to provide 1 μ V at 98 MHz. Tune the receiver to the same frequency so that the center tuning meter pointer indicates its center.
3. Switch the SELECTOR to the FM 25 μ S position. Set the trimming resistors RC01 and RC02 so that the output of the TAPE MONITOR OUT jacks R and L become 580 mV at VTVM.

5. AUDIO ADJUSTMENT

1. Main Amplifier DC off-set alignment
Connect a DC voltmeter with 0.5 or 1 V range between the speaker terminals and adjust the trimming resistor R729 for "zero" DC output on the meter. Repeat the same procedure for the other channel.

NOTE: During this alignment no load should be connected to the speaker terminals.

2. Idle-current adjustment
Connect a VTVM between pin terminals J719 and J729. Next, adjust the trimming resistor R747 so the VTVM reads 25 mV DC. Repeat the same procedure for the other channel.
3. Check DC off-set voltage aligned in the procedure 2 and if any DC output is observed on the DC voltmeter, adjust the R729 again for "zero" output.

6. VOLTAGE CONVERSION FOR EUROPEAN MODEL

The European version of the Model 2385 is equipped with a universal power transformer that may be adjusted to operate at 110 V, 120 V, 220 V, or 240 V AC at 50 to 60 Hz. To convert the unit to a different power source voltage, reposition conversion plug as shown in Figure 2.

CAUTION: DISCONNECT POWER SUPPLY CORD FROM AC OUTLET BEFORE CONVERTING VOLTAGE.

FTZ REGULATION

Instruction for the use in the range other than specified in FTZ codes.

Achtung für die Leute, die in dem Gebiet wohnen, wo die FTZ-Bestimmungen vorherrschend sind.

Sollte das Gerät auch für Frequenzen ausserhalb des in den FTZ-Bestimmungen angegebenen Bereiches empfangebereit sein, bitten wir, den Bereich durch Nachstellen des Kernes in der Oszillatortspule (in der Abbildung mit "FTZ" gekennzeichnet) so zu korrigieren, dass er den Bestimmungen entspricht.

OWNER'S NOTES

7. DIAGRAMS

7.1 BLOCK DIAGRAM

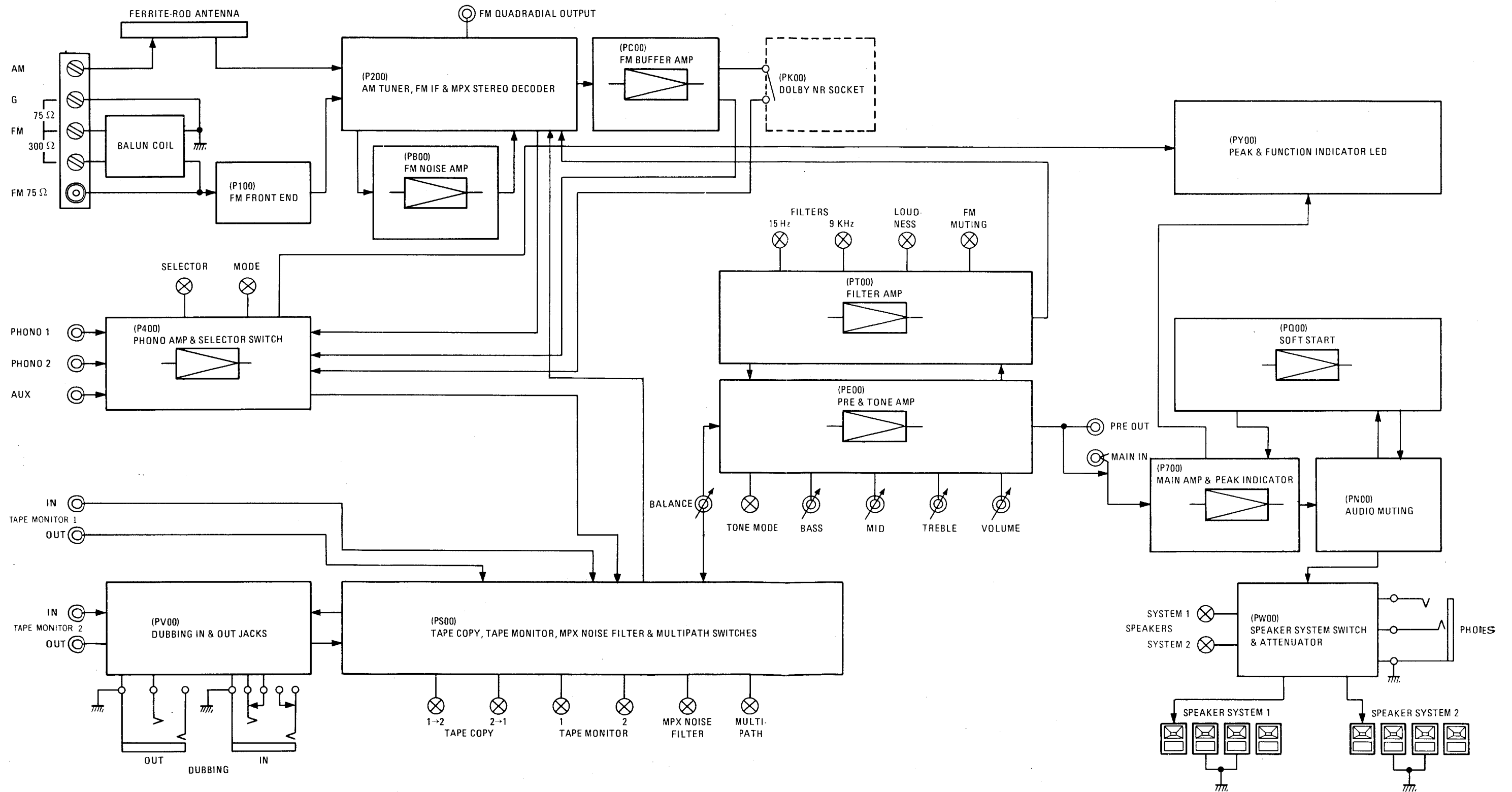

7.2 CONNECTION DIAGRAM - U.S.A. & CANADA

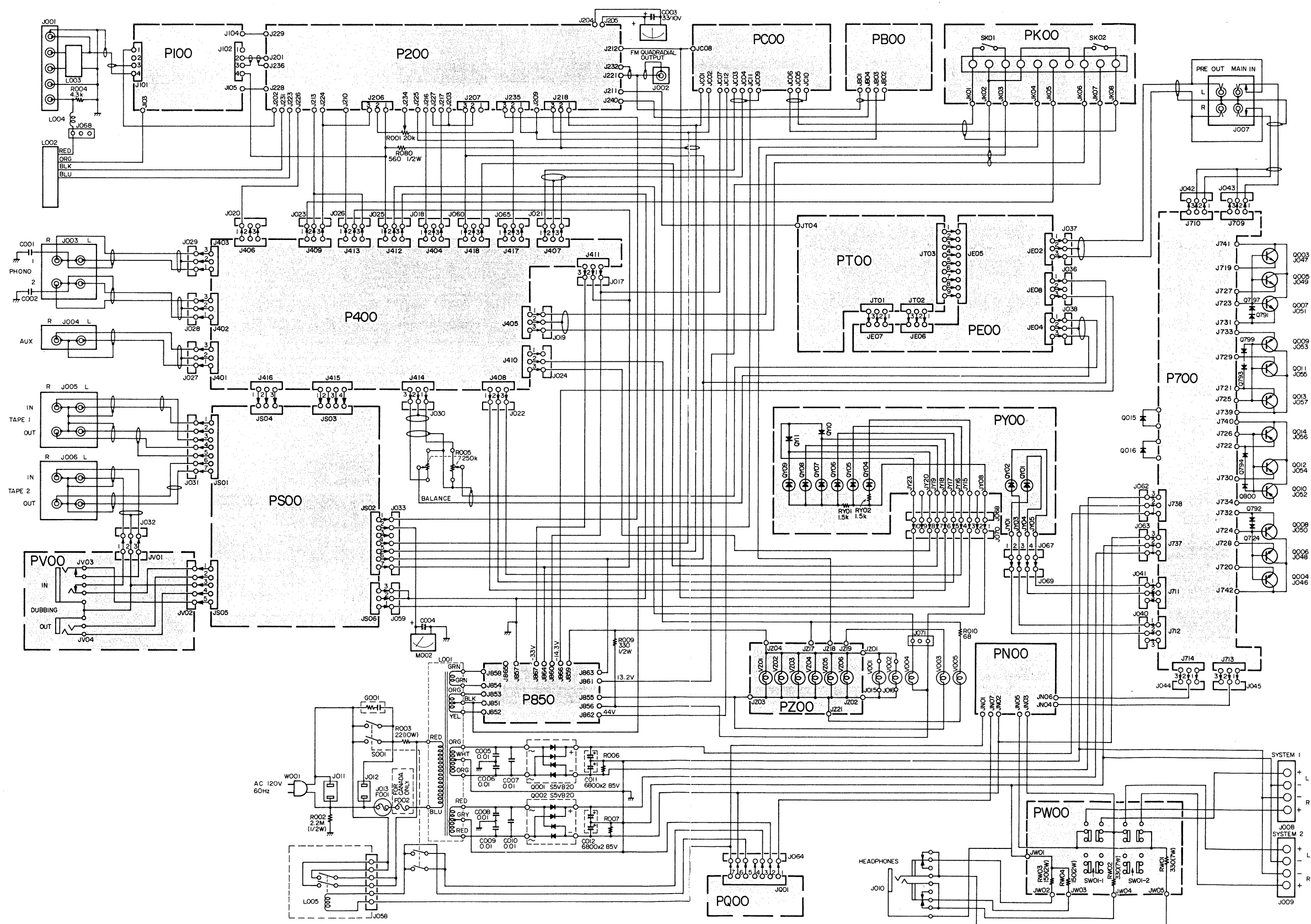

8. SCHEMATIC DIAGRAMS AND COMPONENT LOCATIONS

8.1 FM FRONT END CIRCUIT BOARD P100

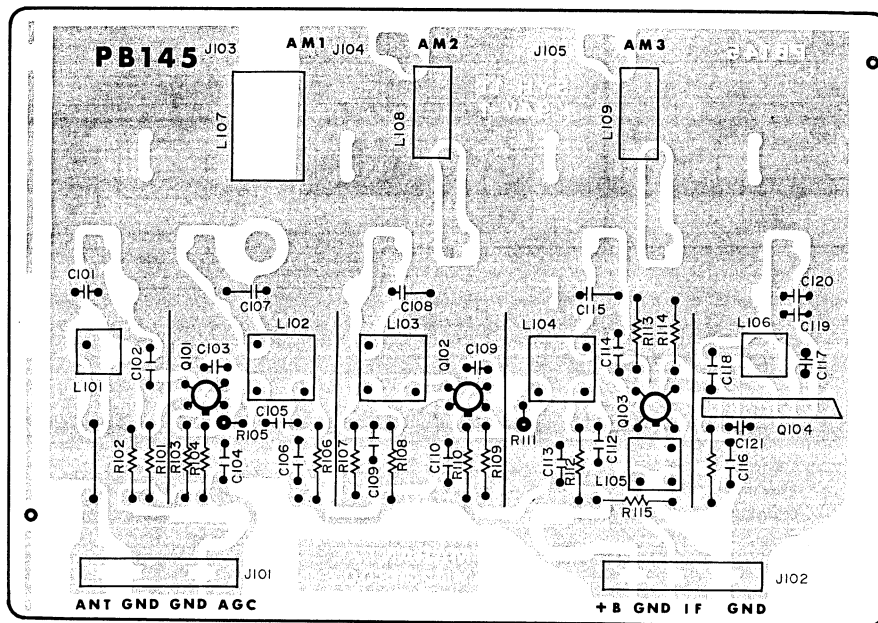
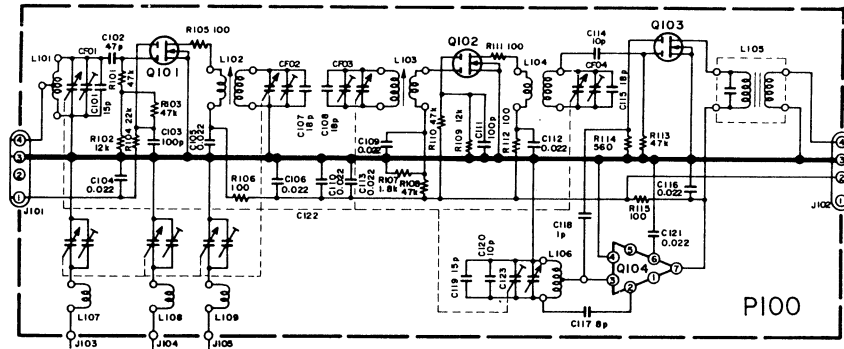

8.2 AM TUNER, FM IF & MPX STEREO DECODER CIRCUIT BOARD P200

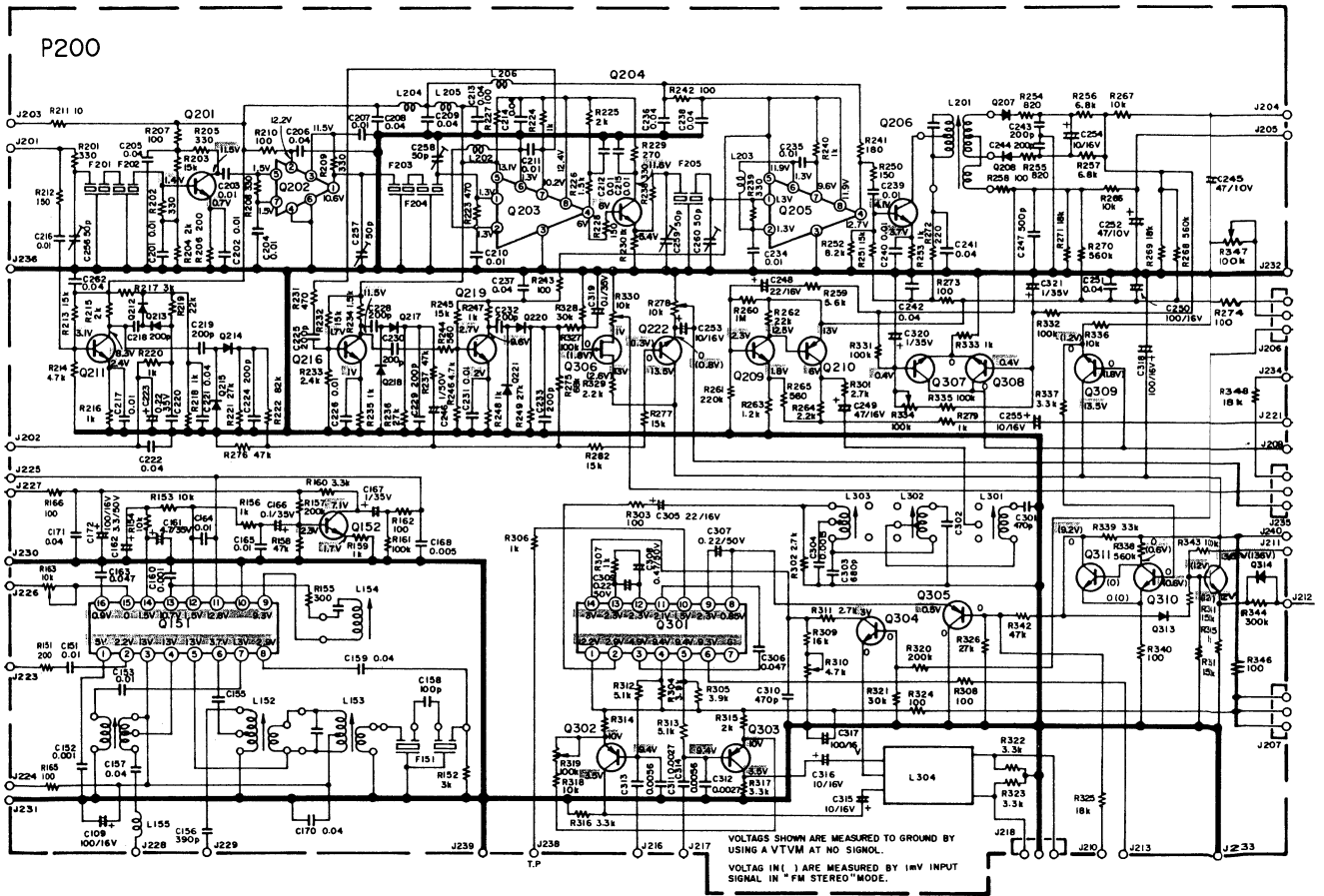

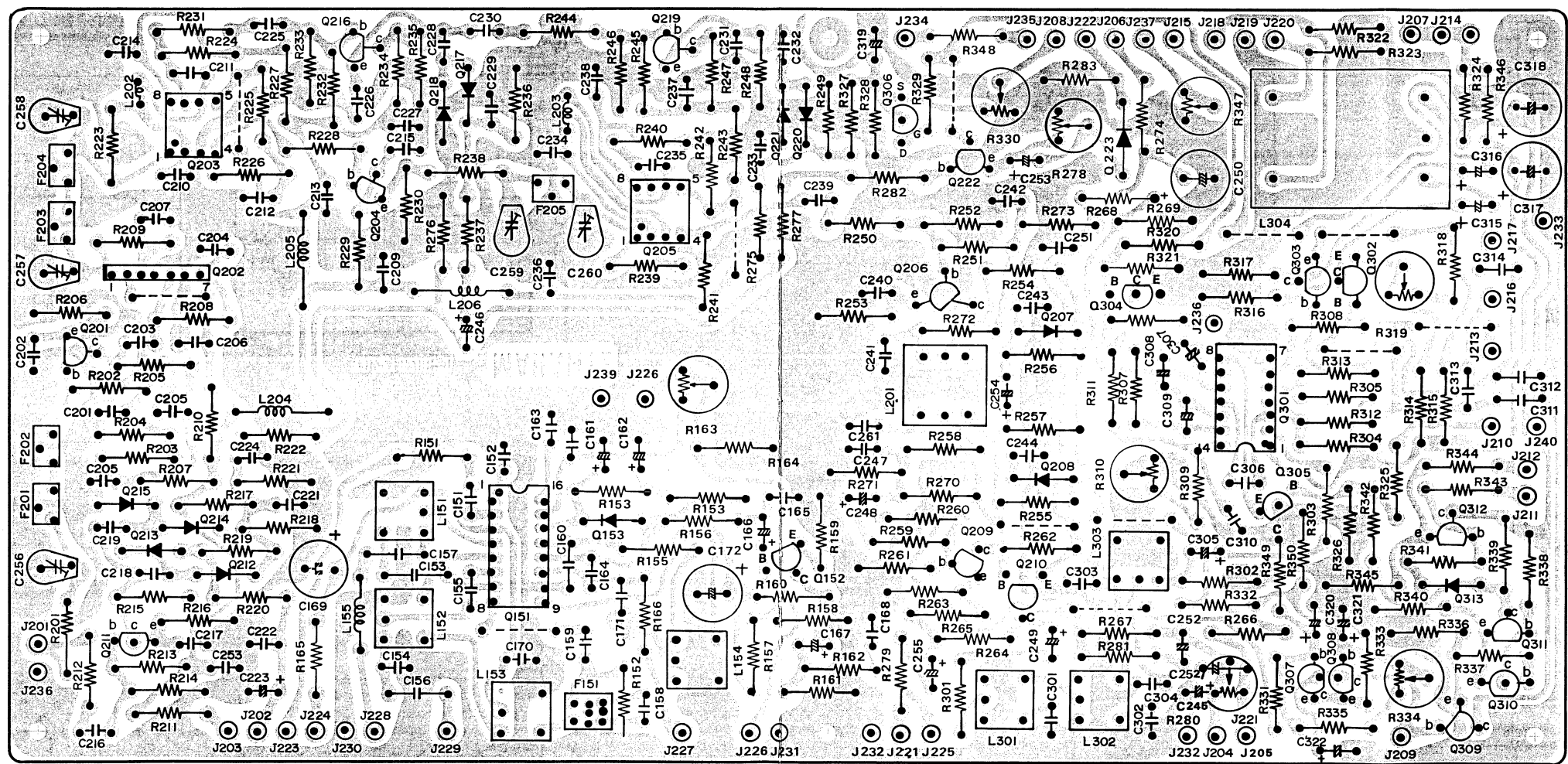

8.3 FM NOISE AMP CIRCUIT BOARD PB00

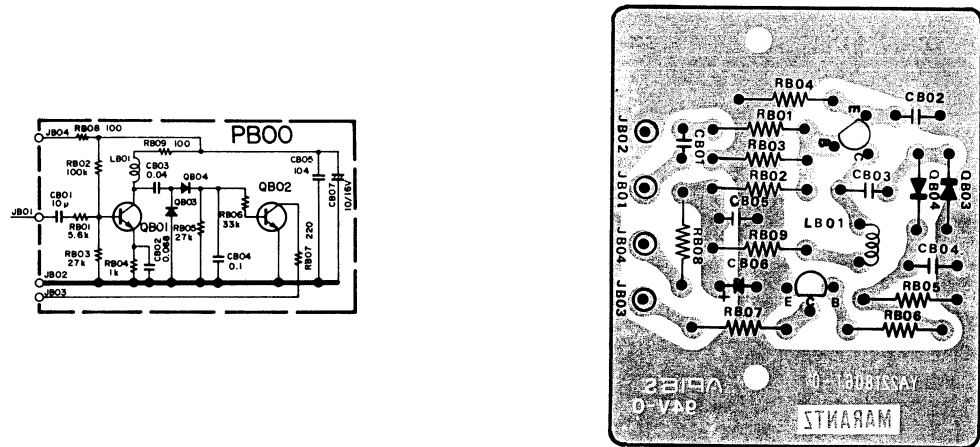

8.4 FM BUFFER AMP CIRCUIT BOARD PC00

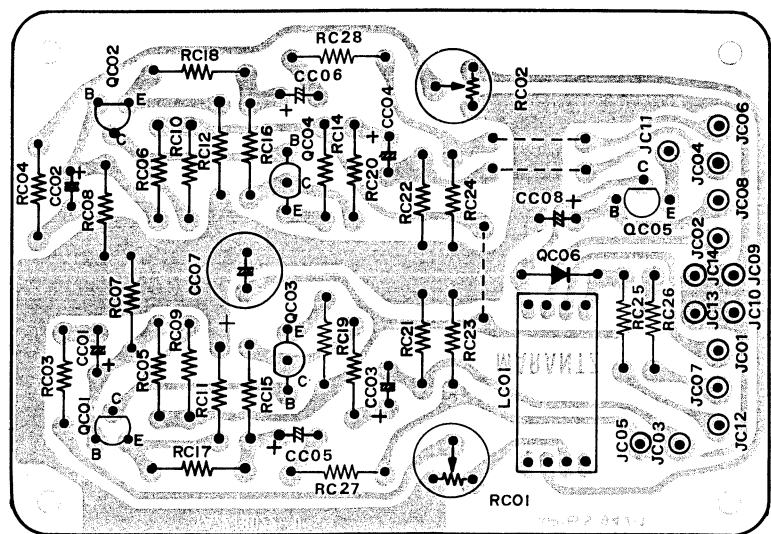
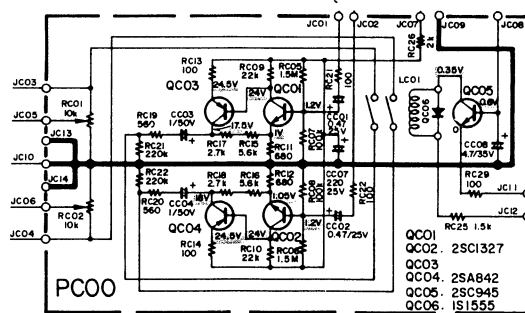

8.5 PHONO AMP & SELECTOR SWITCH CIRCUIT BOARD P400

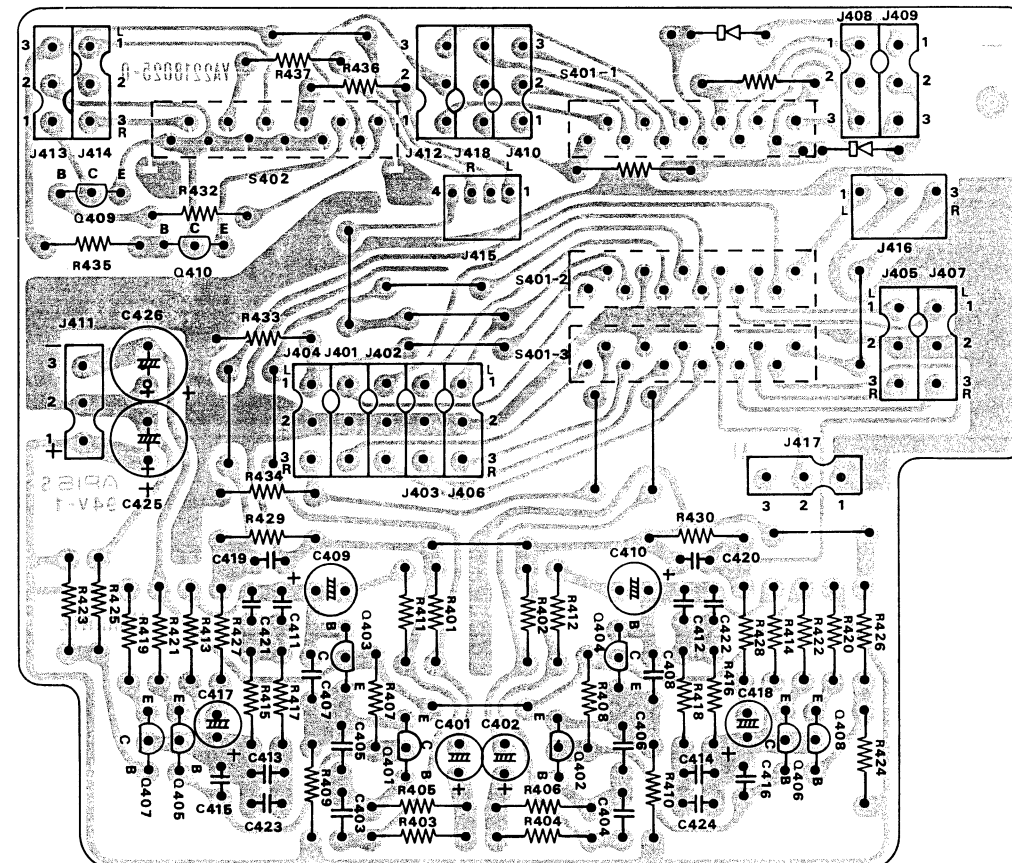
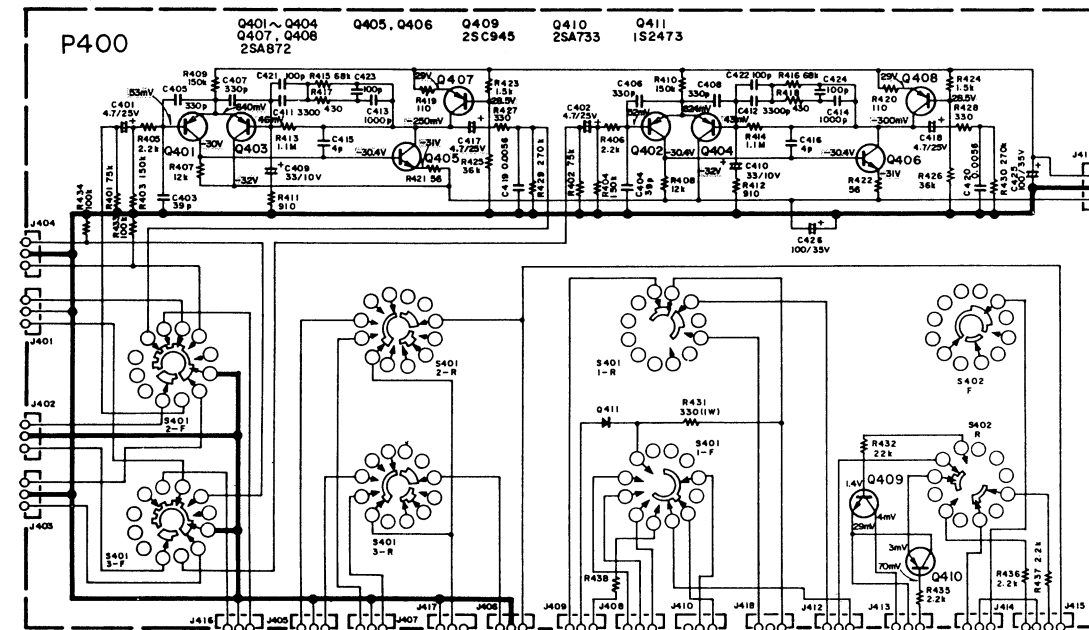

8.6 POWER SUPPLY CIRCUIT BOARD P850

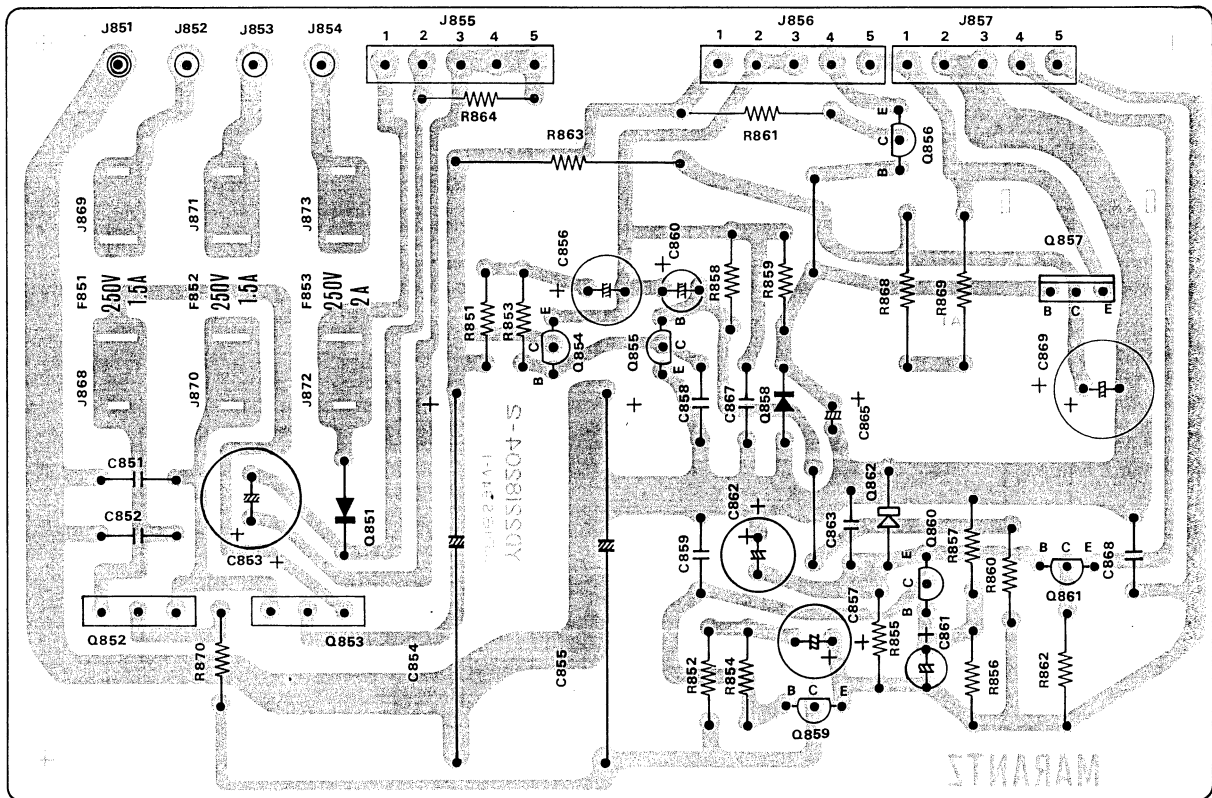
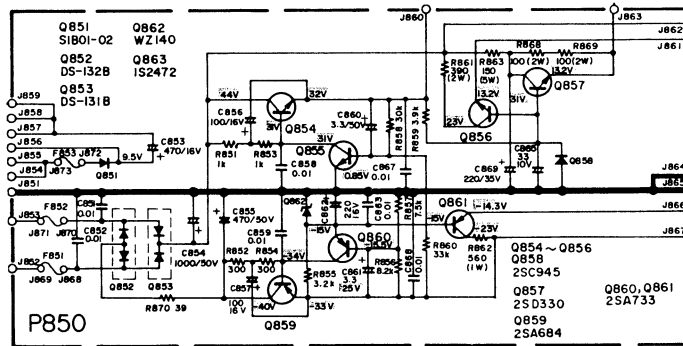

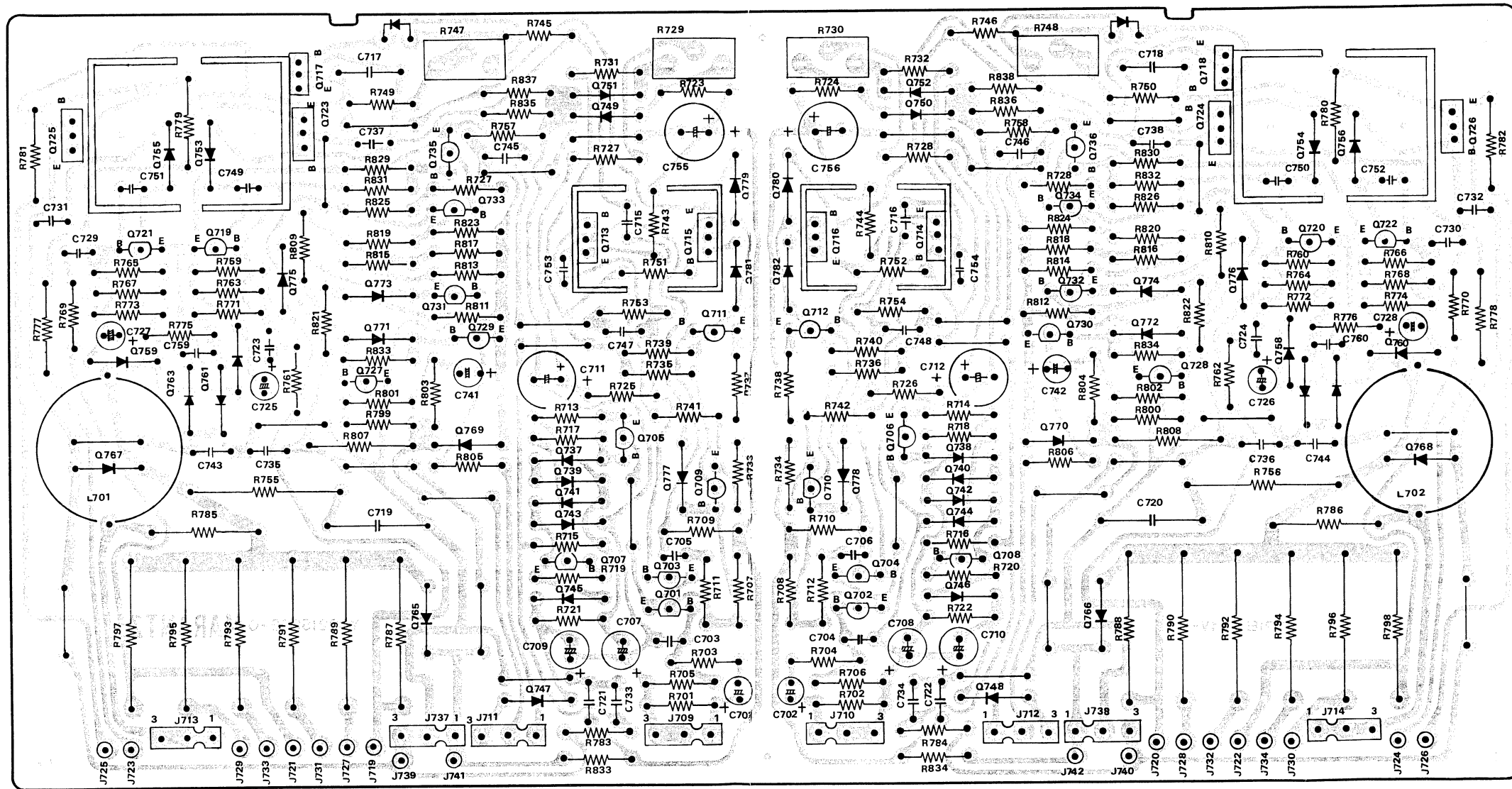

8.8 PRE & TONE AMP CIRCUIT BOARD PE00

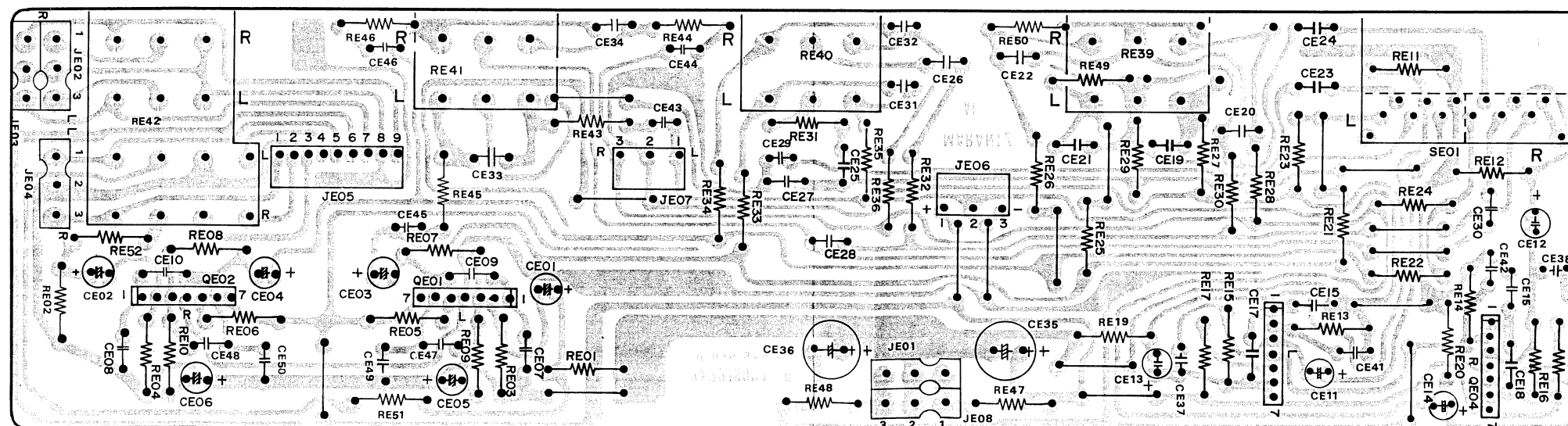
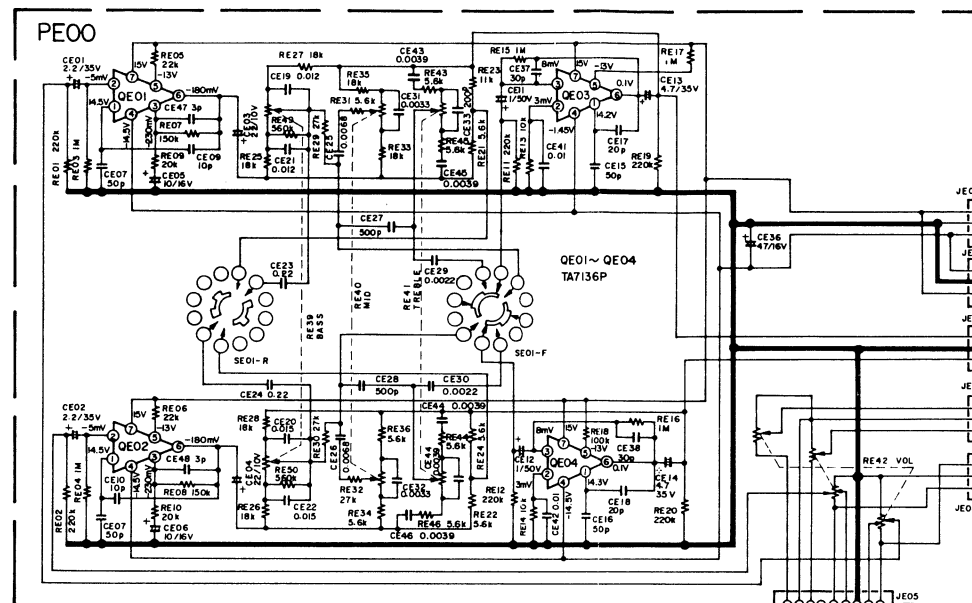

8.9 DOLBY NR SOCKET CIRCUIT BOARD PK00

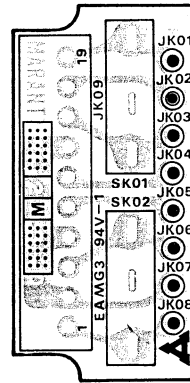
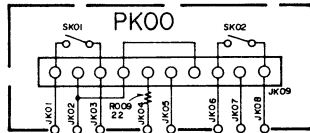

8.10 AUDIO MUTING CIRCUIT BOARD PN00

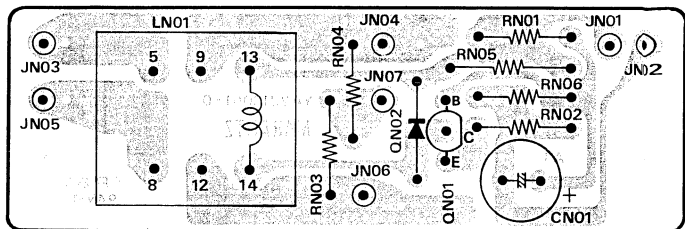
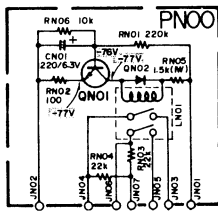

8.11 SOFT START CIRCUIT BOARD PQ00

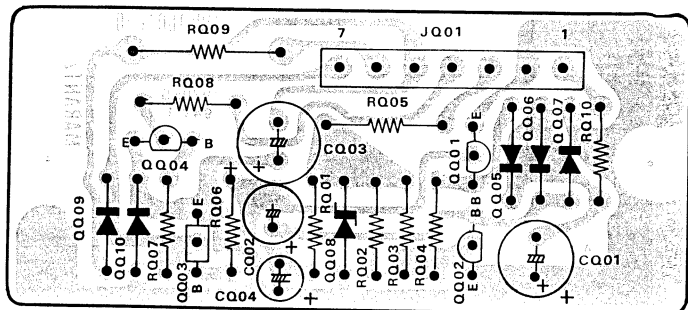
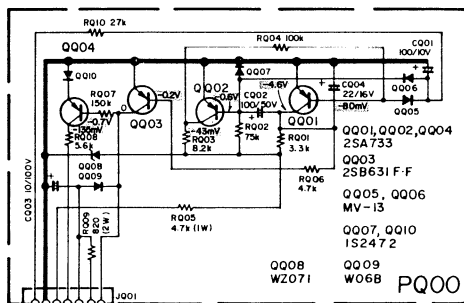

8.12 TAPE COPY, TAPE MONITOR, MPX NOISE FILTER & MULTIPATH SWITCHES CIRCUIT BOARD PS00

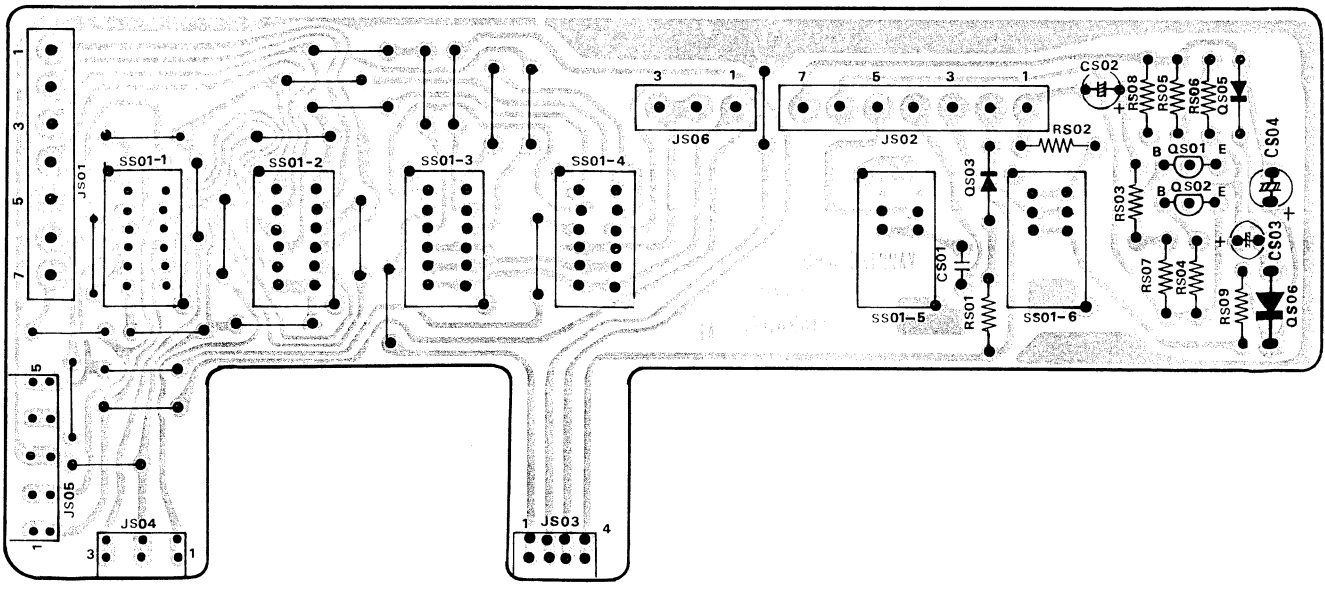
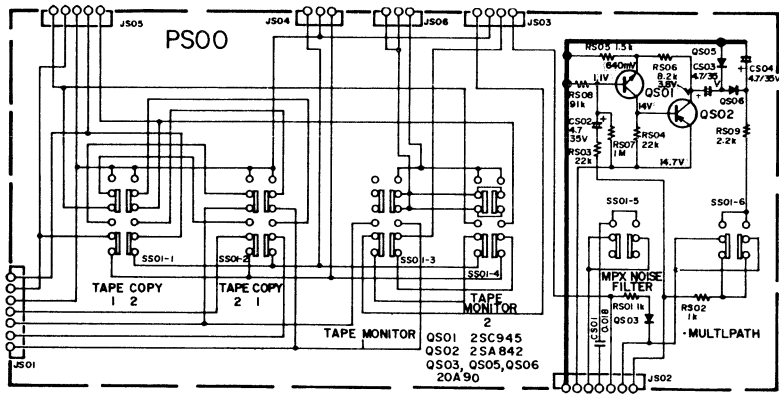

8.13 DUBBING IN & OUT JACKS BOARD PV00

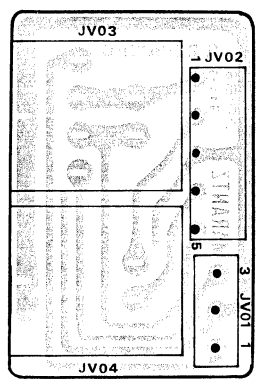
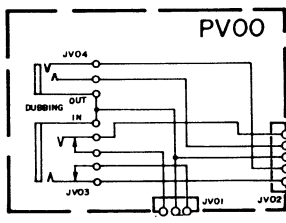

8.14 FILTER AMP CIRCUIT BOARD PT00

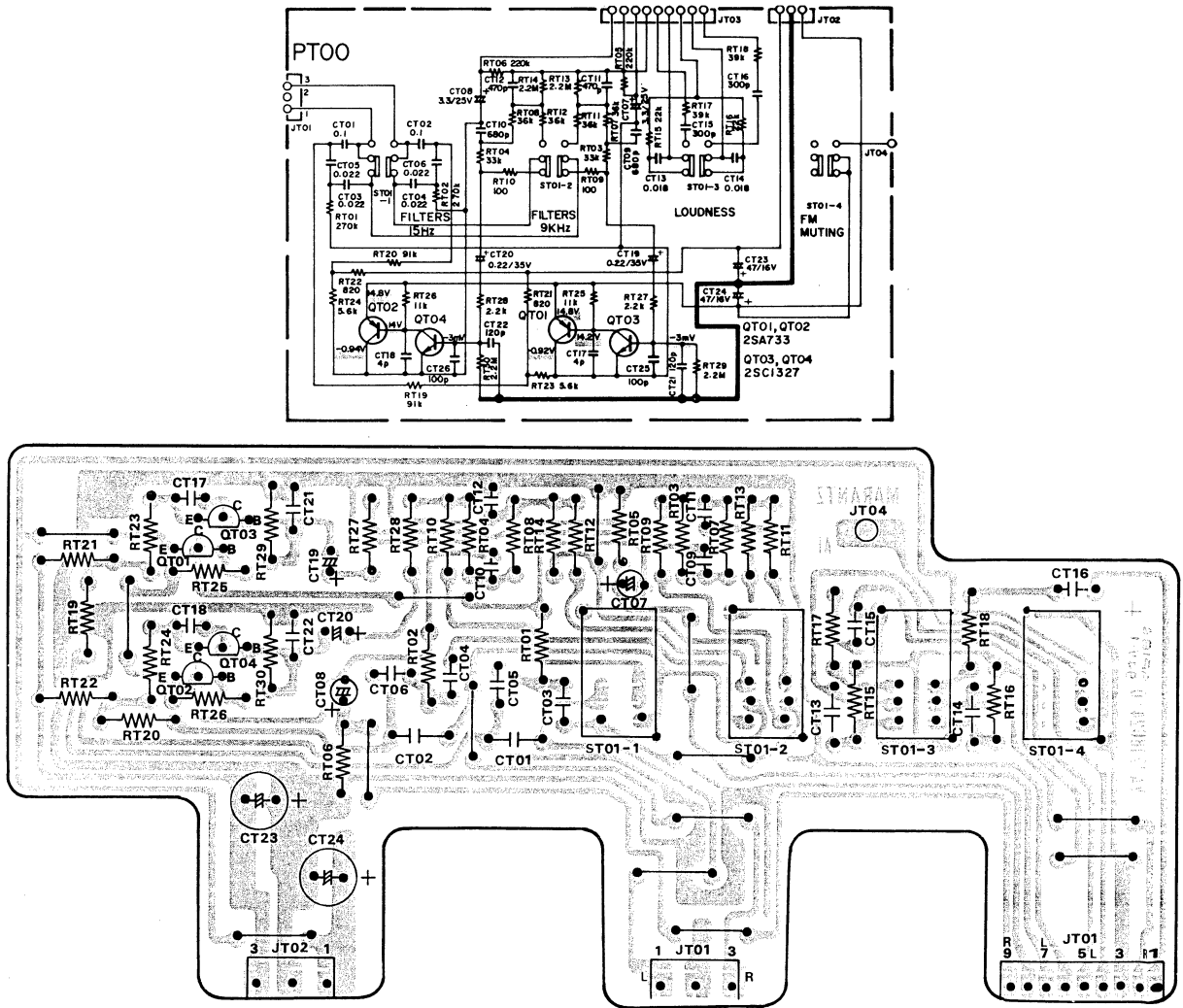

8.15 SPEAKER SYSTEM SWITCH & ATTENUATOR CIRCUIT BOARD PW00

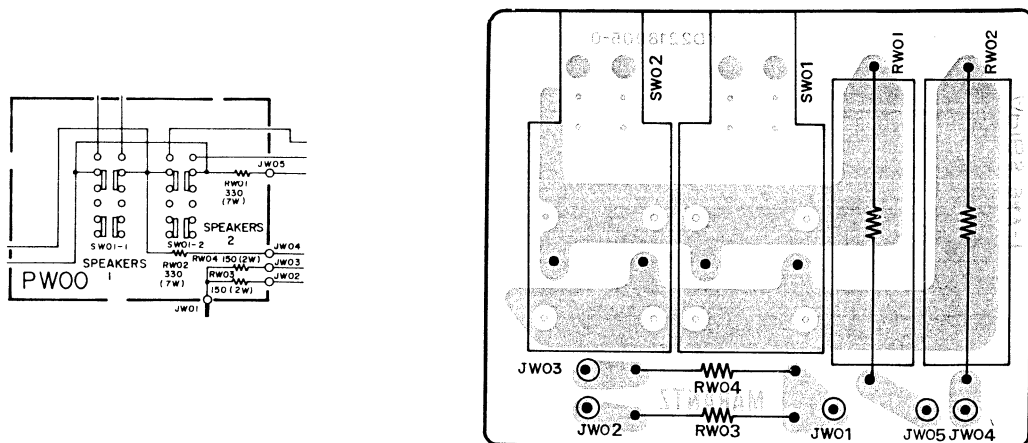

8.16 PEAK & FUNCTION INDICATOR LED CIRCUIT BOARD PY00

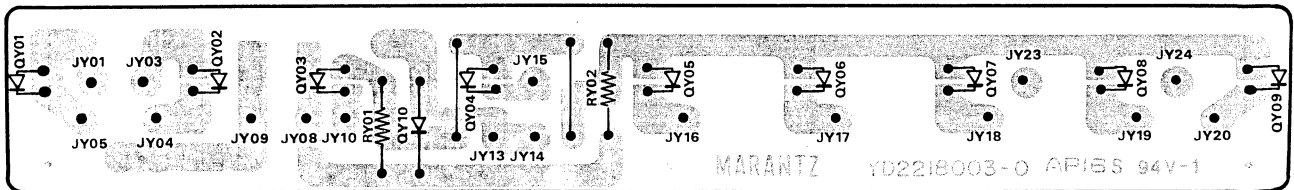
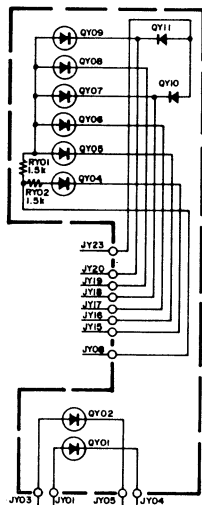

8.17 DIAL LAMP CIRCUIT BOARD PZ00

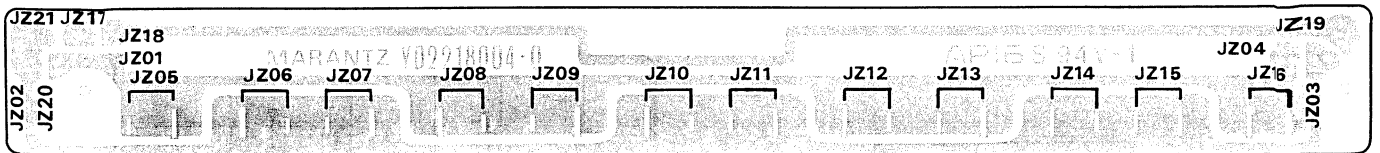
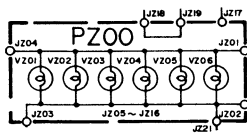

9. MAJOR COMPONENT LOCATIONS

9.1 CABINET - FRONT VIEW - U.S.A. & CANADA

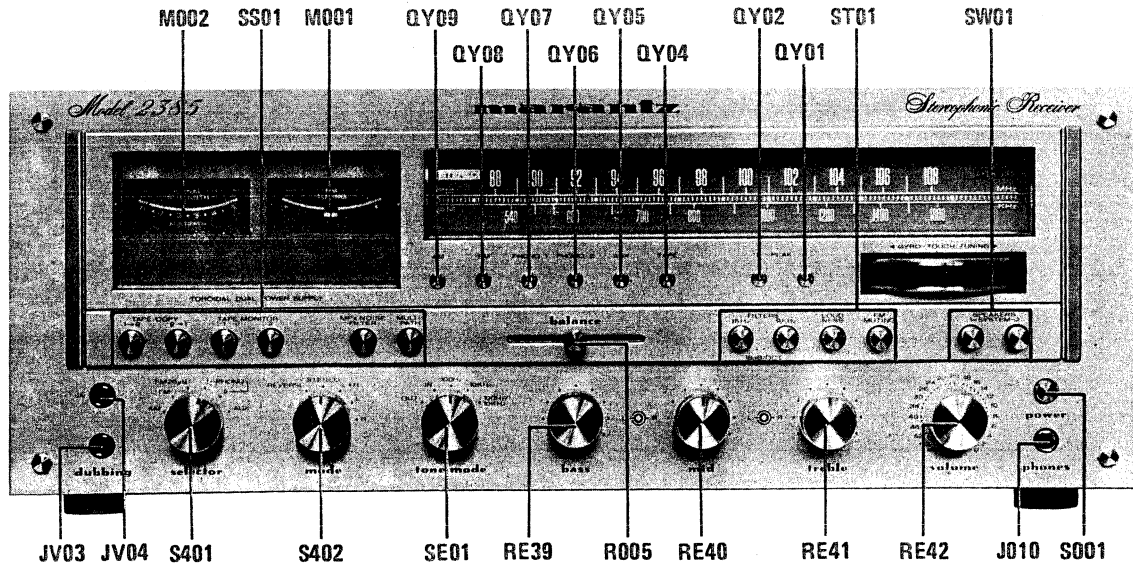

9.2 CHASSIS - TOP VIEW - U.S.A. & CANADA

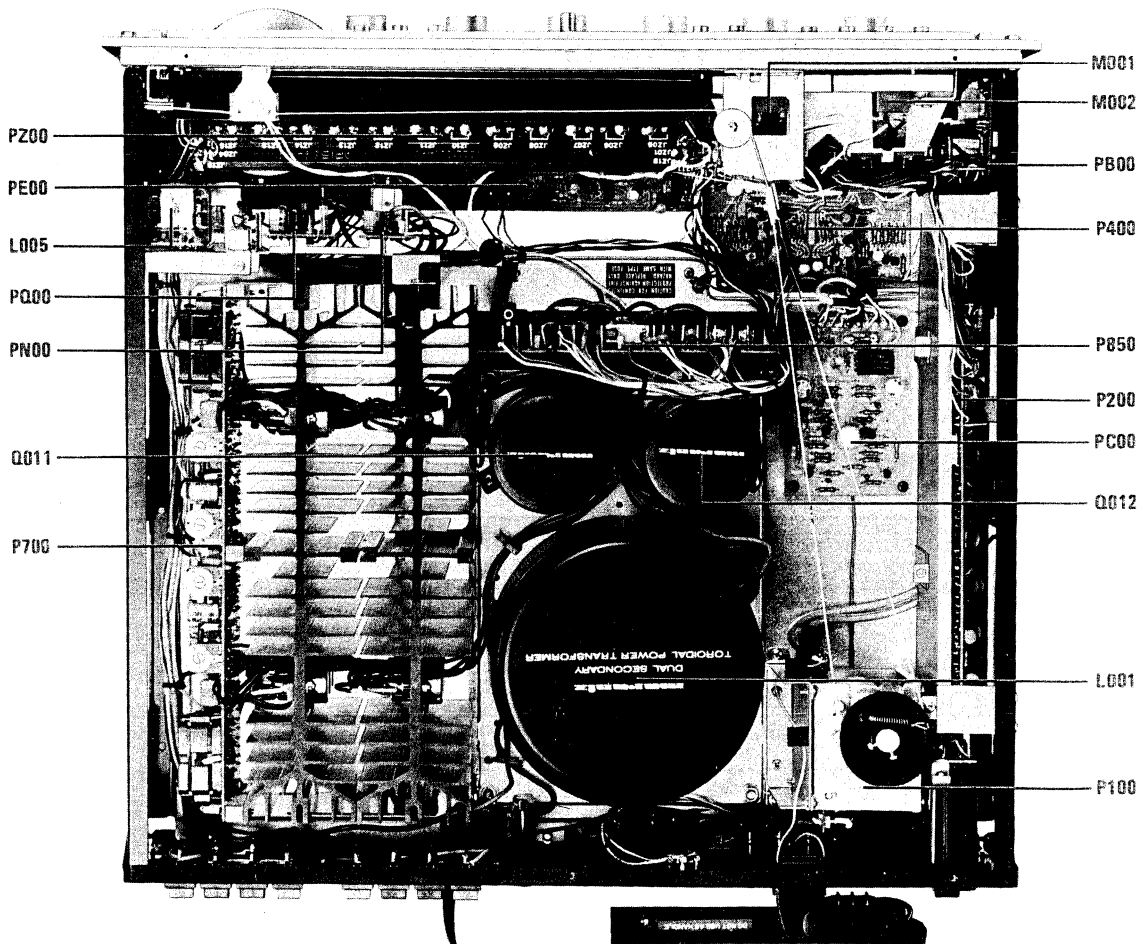

9.3 CABINET - REAR VIEW - U.S.A. & CANADA

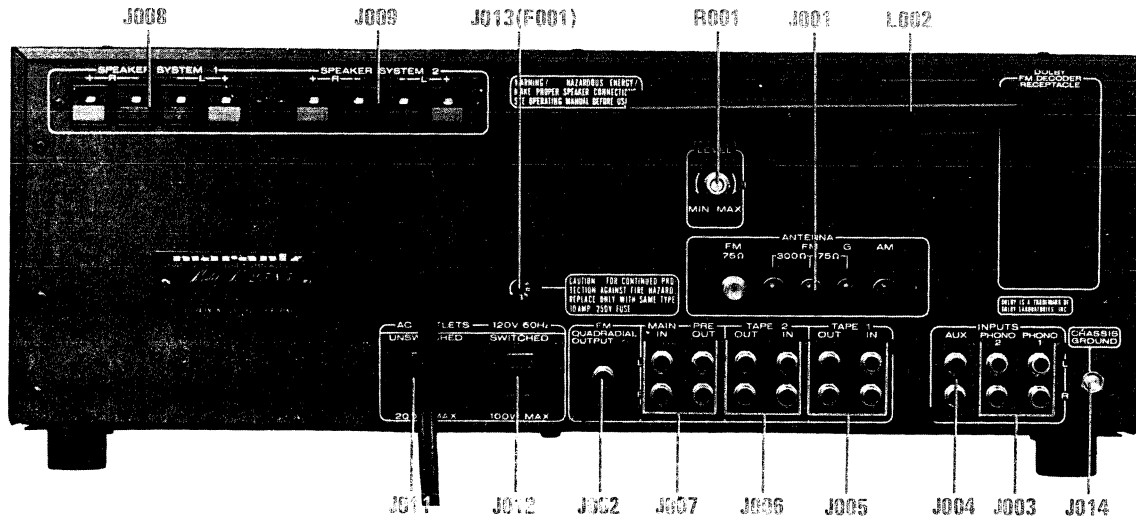

9.4 CHASSIS - BOTTOM VIEW - U.S.A. & CANADA

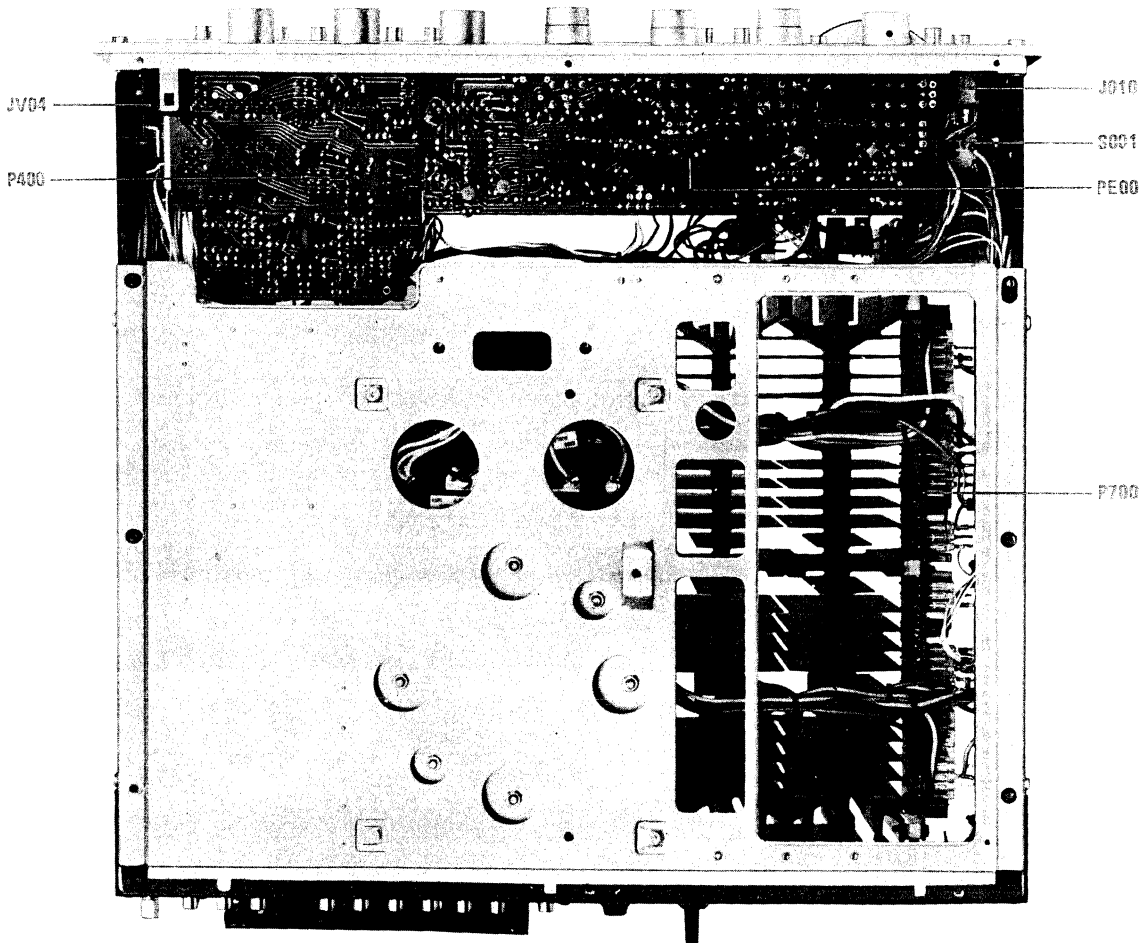

9.5 CABINET - FRONT VIEW - EUROPE

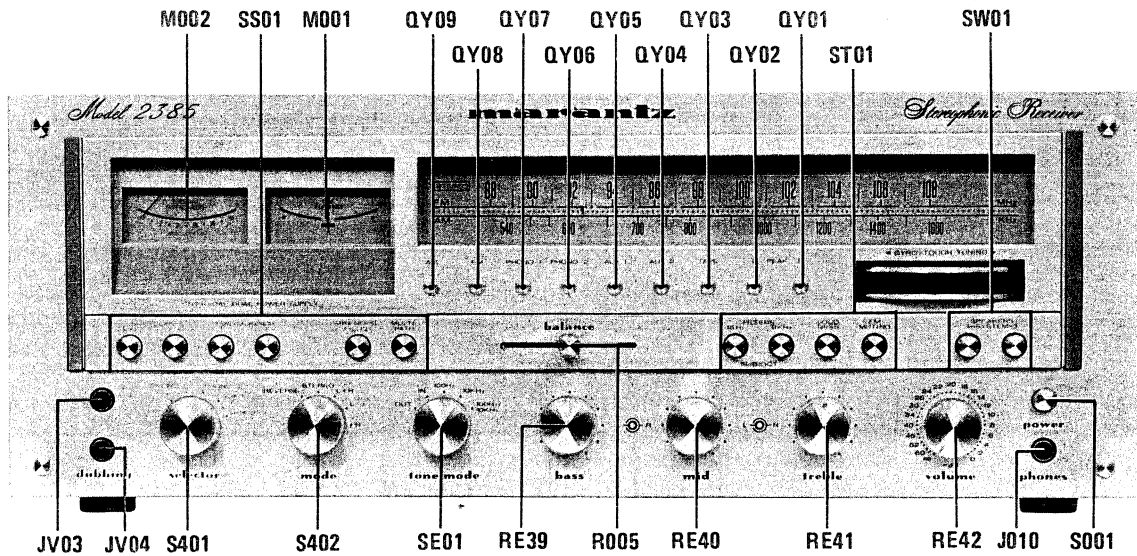

9.6 CHASSIS - TOP VIEW - EUROPE

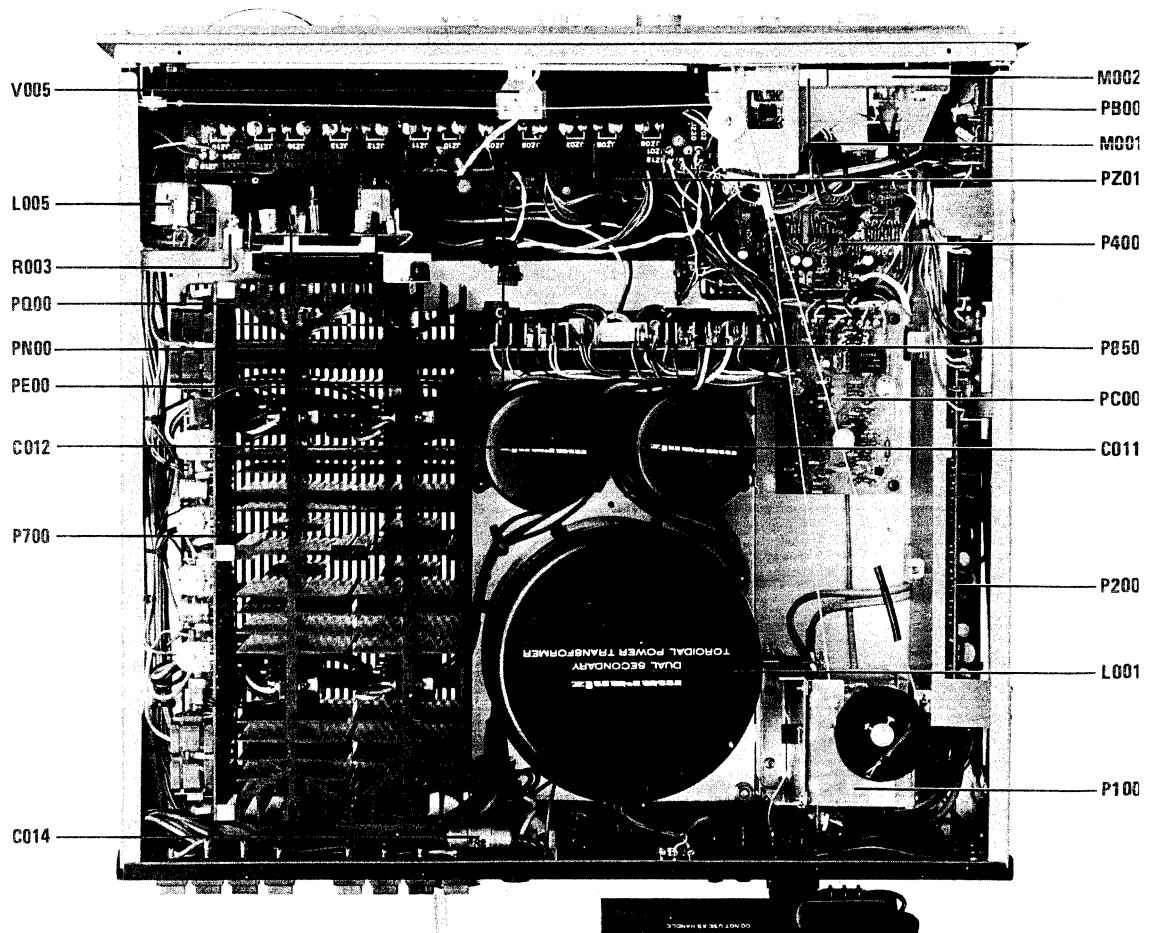

9.7 CABINET - REAR VIEW - EUROPE

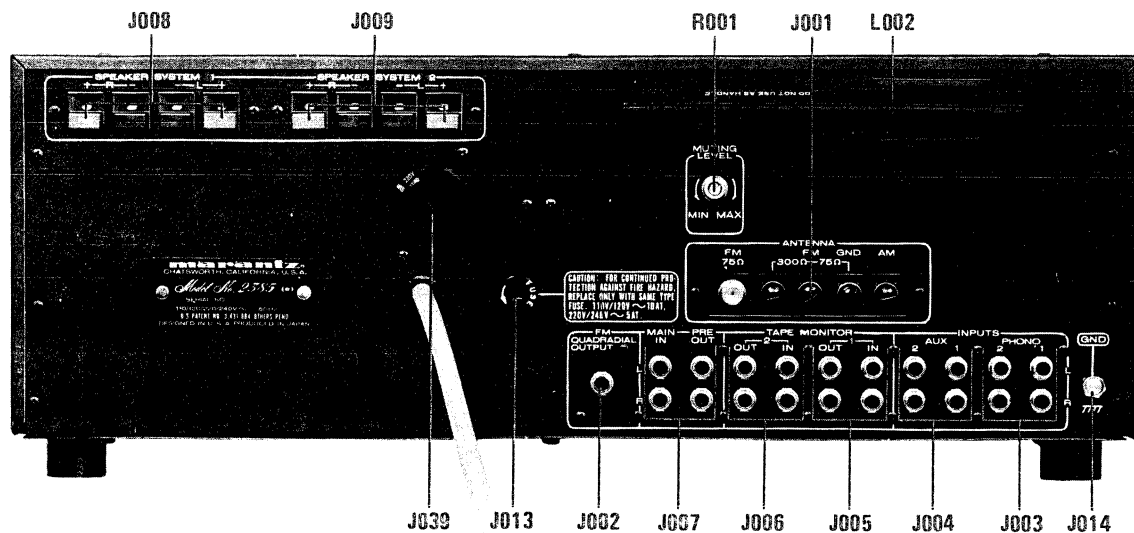

9.8 CHASSIS - BOTTOM VIEW - EUROPE

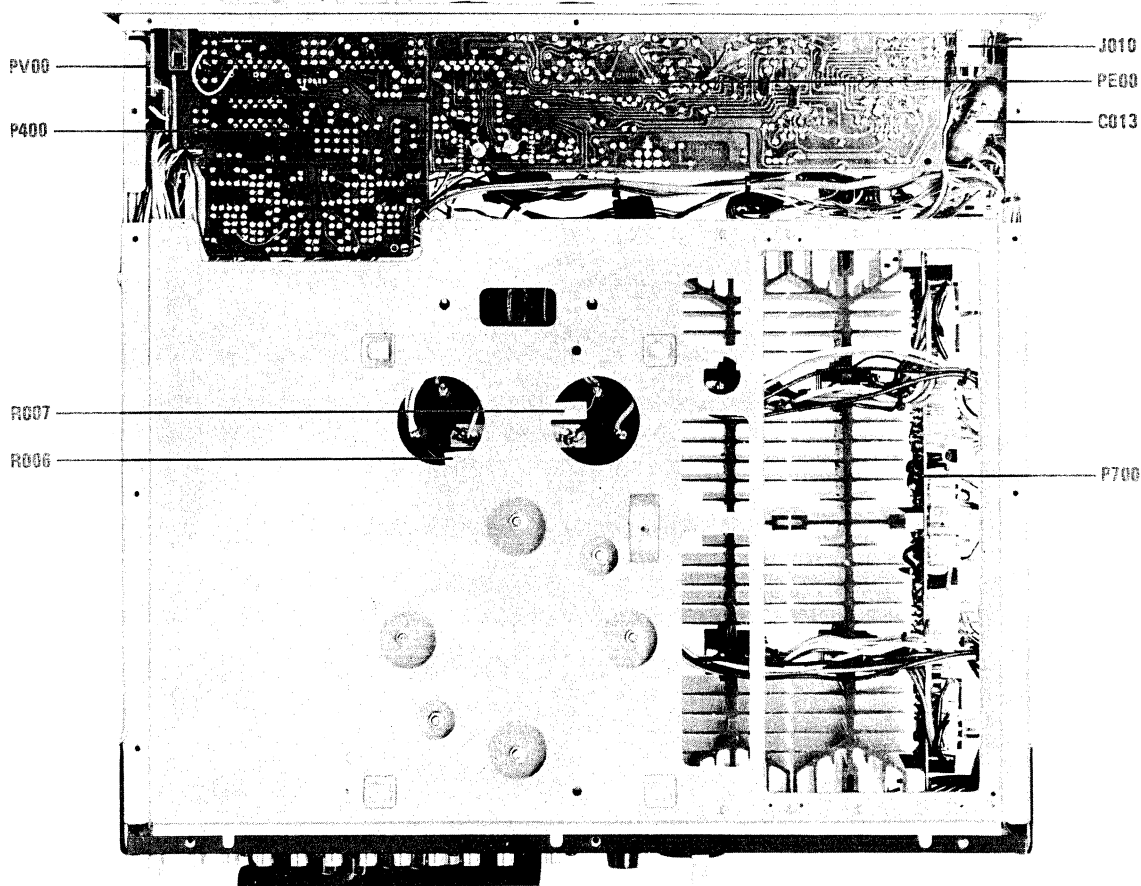

10. EXPLODED VIEWS

10.1 FRONT PANEL EXPLODED VIEW

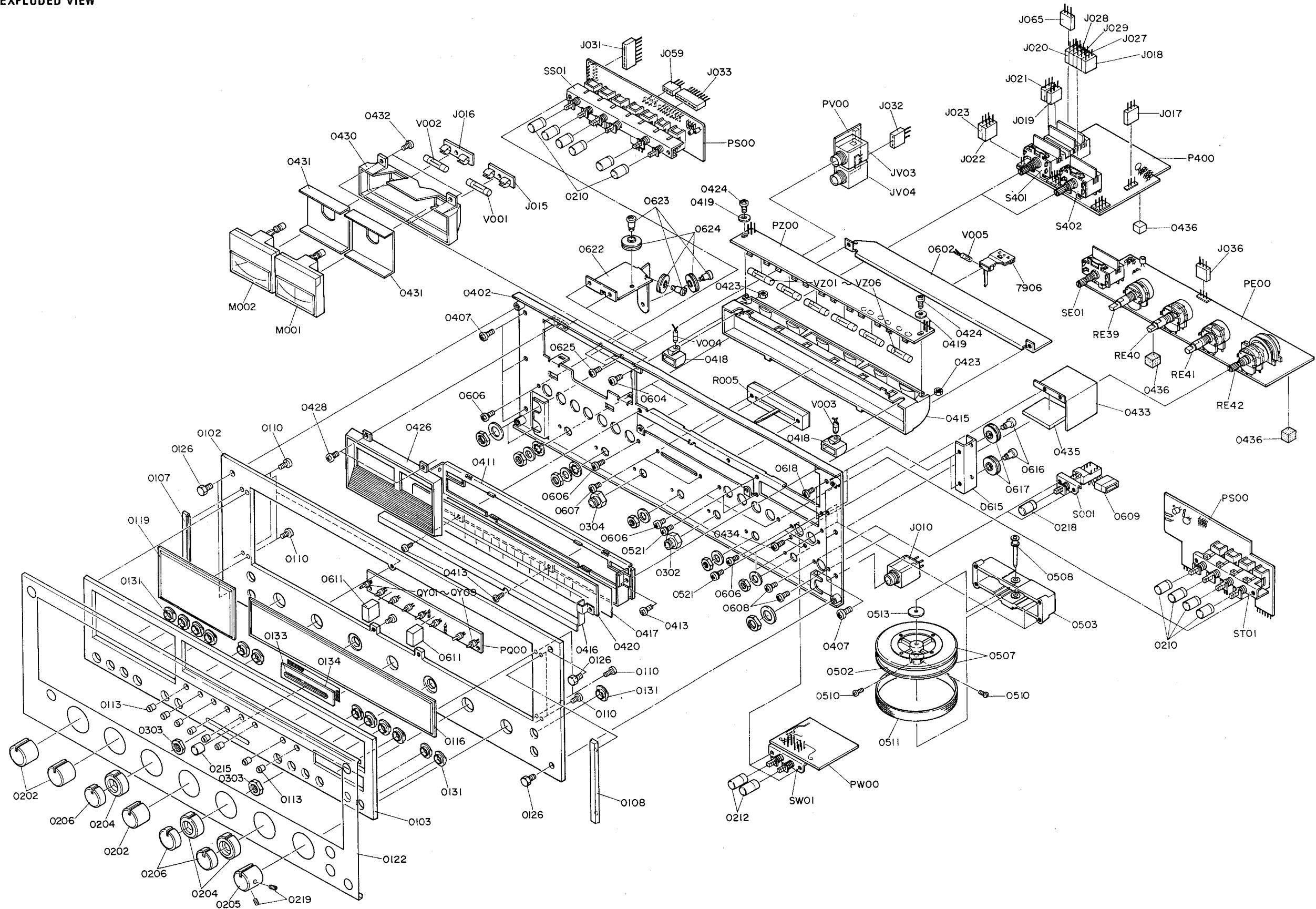

10.4 PACKING MATERIAL EXPLODED VIEW

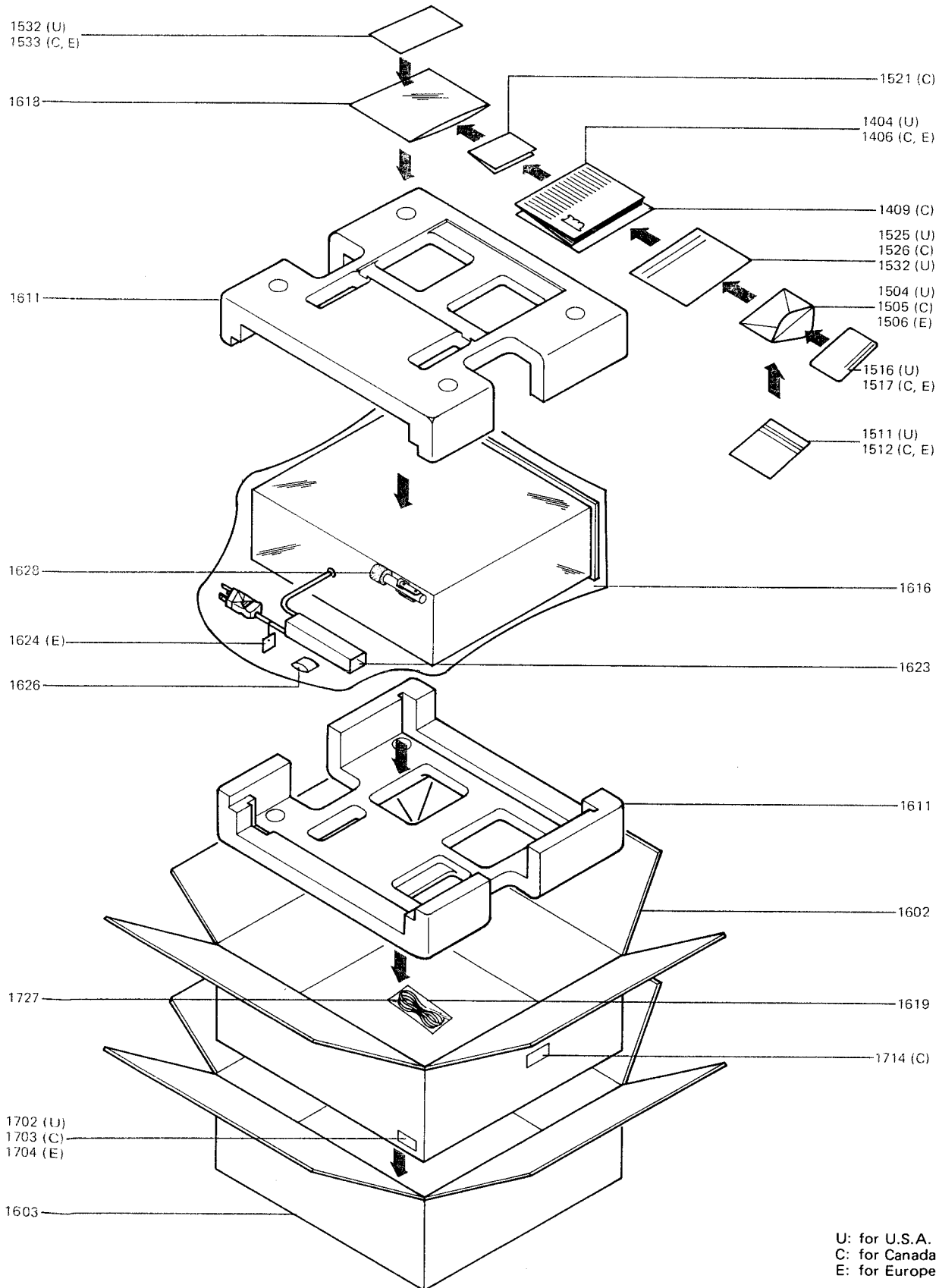

11. PARTS LIST

U : For U.S.A.
 C : For Canada
 E : For Europe

REF. DESIG.	Q'TY			PART NO.	DESCRIPTION
	U	C	E		
A	1	1		2218063400	Front Panel Assembly
A1			1	2218063410	Front Panel Assembly
0102	1	1	1	2218063014	Escutcheon
0103	1	1		2218063024	Escutcheon
0105			1	2218063120	Escutcheon
0107	1	1	1	2218063030	Escutcheon
0108	1	1	1	2218063040	Escutcheon
0110	10	10	10	51280308B0	B.H. Tapped Screw, B3x8ST
0113	8	8	9	2979259020	Bushing
0116	1	1	1	2219158110	Window
0119	1	1	1	2218158110	Window
0122	1	1	1	2218053010	Cover
0131	13	13	13	2978259010	Bushing
0133	1	1	1	2854259110	Bushing
0134	1	1	1	2219107020	Sheet
B	1	1	1	2218257400	Lid Assembly, Upper
0311	1	1	1	2218257010	Lid
0312	4	4	4	2577118070	Spacer
C	1	1	1	2219159400	Drum Assembly
0831	1	1	1	2219159010	Drum
0832	1	1	1	71101569M0	Spring
0833	2	2	2	51064019A9	Set Screw
D	1	1	1	2219273400	Flywheel Assembly
0502	1	1	1	2219273010	Flywheel
0507	2	2	2	2219063030	Escutcheon
0510	1	1	1	51820206B0	P.H.M. Screw, P2x6
0511	1	1	1	2219353010	Ring
E	1	1	1	1202006430	Hook Assembly
0834	1	1	1	1202258010	Hook
0835	1	1	1	72071605A0	String
0126	4	4	4	52017059J0	Bolt
0202	4	4	4	2221154230	Knob
0204	3	3	3	2210154220	Knob, Bass, Mid, Treble
0206	3	3	3	2210154210	Knob, Bass, Mid, Treble
0210	10	10	10	2218154010	Knob
0212	2	2	2	2218154020	Knob
0215	1	1	1	2970154013	Knob, Balance
0218	1	1	1	2970154033	Knob, Power
0302	1	1	1	2219101010	Support
0303	2	2	2	53118129G0	Hexagon Nut
0304	1	1	1	2219101020	Support
0314	6	6	6	51280306U0	B.H. Tapped Screw B, 3x6
0315	6	6	6	51480406S9	B.H.M. Screw F, 4x6
0321	1	1	1	2218257020	Lid
0322	4	4	4	51570410S9	P.H. Tapped Screw, P4x10ST
0323	4	4	4	2759057012	Leg
0325	13	13	13	51280410U0	B.H. Tapped Screw B, 4x10
0402	1	1	1	2218160012	Bracket
0404	1	1	1	2218160022	Bracket
0405	1	1	1	2218160032	Bracket
0407	6	6	6	51280408B0	B.H. Tapped Screw B, 4x8
0408	4	4	4	51280406B0	B.H. Tapped Screw B, 4x6
0411	1	1	1	2218271010	Holder

REF. DESIG.	Q'TY			PART NO.	DESCRIPTION
	U	C	E		
0413	3	3	3	51280306B0	B.H. Tapped Screw B, 3x6
0415	1	1	1	2218274010	Reflector
0418	2	2	1	2218274030	Reflector
0420	1	1		2218302010	Dial
0421			1	2218302020	Dial
0423	2	2	2	53110303E9	Hexagon Nut
0424	2	2	2	51100308A9	B.H.M. Screw, B3x8
0426	1	1	1	2218401010	Frame
0428	2	2	2	51280308U0	B.H. Tapped Screw B, 3x8
0430	1	1	1	2218274020	Reflector
0432	2	2	2	51280306B0	B.H. Tapped Screw B, 3x6
0503	1	1	1	2219104500	Retainer K
0508	1	1	1	2219112010	Shaft
0513	1	1	1	59031405G9	Washer
0521	4	4	4	51470306A9	B.H.M. Screw S, 3x6
0602	1	1	1	2218051010	Guide
0604	2	2	2	51100306A9	B.H.M. Screw, B3x6
0606	6	6	6	51100306A9	B.H.M. Screw, B3x6
0607	2	2	2	51100306A9	B.H.M. Screw, B3x6
0608	2	2	2	51100306A9	B.H.M. Screw, B3x6
0611	2	2	2	51280306B0	B.H. Tapped Screw B, 3x6
0614	1	1	1	2218262500	Pulley K
0618	3	3	3	51280306B0	B.H. Tapped Screw B, 3x6
0621	3	3	3	2218262510	Pulley K
0625	2	2	2	51280306B0	B.H. Tapped Screw B, 3x6
0702	1	1	1	2218105012	Chassis
0704	1	1	1	2218105022	Chassis
0706	1	1	1	2218267022	Heatsink
0707	3	3	3	51280306B0	B.H. Tapped Screw B, 3x6
0708	3	3	3	51280306U0	B.H. Tapped Screw B, 3x6
0709	2	2	2	2218271020	Holder
0710	4	4	4	53250501A0	Special Nut
0712	2	2	2	51280312B0	B.H. Tapped Screw B, 3x12
0716	6	6	6	51280408B0	B.H. Tapped Screw B, 4x8
0718	4	4	4	53110401A9	Hexagon Nut
0719	4	4	4	54040402N0	Spring Washer
0721	1	1	1	2947267050	Heatsink
0722	1	1	1	53110303E9	Hexagon Nut
0723	1	1	1	51100308S9	B.H.M. Screw, B3x8
0726	1	1	1	2218123010	Contactora
0727	1	1	1	51280306B0	B.H. Tapped Screw B, 3x6
0731	1	1	1	2886005060	Clamper
0802	1	1	1	2218160050	Bracket
0803	6	6	6	51280306B0	B.H. Tapped Screw B, 3x6
0805	2	2	2	2218160060	Bracket
0806	4	4	4	51280306B0	B.H. Tapped Screw B, 3x6
0807	2	2	2	51280306B0	B.H. Tapped Screw B, 3x6
0818	2	2	2	2218160090	Bracket
0811	4	4	4	51280306B0	B.H. Tapped Screw B, 3x6
0812	2	2	2	51280306B0	B.H. Tapped Screw B, 3x6
0815	4	4	4	51100306S9	B.H.M. Screw, B3x6
0817	1	1	1	2908109022	Shield
0821	1	1	1	2218160080	Bracket
0822	4	4	4	51280306B0	B.H. Tapped Screw B, 3x6
0823	1	1	1	2218160040	Bracket
0824	2	2	2	51100306A0	B.H.M. Screw, B3x6
0825	5	5	5	51280306B0	B.H. Tapped Screw B, 3x6
0830	1	1	1	56382540G0	Eyelet
0902	2	2	2	2218267012	Heatsink
0906	2	2	2	2218160122	Bracket
0908	3	3	3	2963160100	Bracket
0910	6	6	6	51280406U0	B.H. Tapped Screw B, 4x6
0911	6	6	6	51280306U0	B.H. Tapped Screw B, 3x6
0912	8	8	8	51280408U0	B.H. Tapped Screw B, 4x8
0913	6	6	6	51280306B0	B.H. Tapped Screw B, 3x6

U : For U.S.A.
C : For Canada
E : For Europe

REF. DESIG.	Q'TY			PART NO.	DESCRIPTION
	U	C	E		
0916	1	1	1	2218160070	Bracket
0917	1	1	1	2218109010	Shield
0918	4	4	4	51280306B0	B.H. Tapped Screw B, 3x6
0919	4	4	4	51280306U0	B.H. Tapped Screw B, 3x6
0920	1	1	1	51280306B0	B.H. Tapped Screw B, 3x6
0921	1	1	1	51280406B0	B.H. Tapped Screw B, 4x6
0926	24	24	24	51100314B9	B.H.M. Screw, B3x14
0927	2	2	2	51100312S9	B.H. Tapped Screw, B3x12ST
0928	2	2	2	53110303E9	Hexagon Nut
0929	2	2	2	54020301A0	Flat Washer P
1002	4	4	4	2212267020	Heatsink
1003	4	4	4	51100306S9	B.H.M. Screw, B3x6
1004	6	6	6	51280308U0	B.H. Tapped Screw, B3x8ST
1009	4	4	4	2917267022	Heatsink
1010	4	4	4	51100308S9	B.H.M. Screw, B3x8
1011	4	4	4	53110303E9	Hexagon Nut
1102	1	1	1	2218160212	Bracket
1103	1	1	1	2218160220	Bracket
1106	1	1	1	2218271050	Holder
1107	1	1	1	2218258010	Hook
1108	1	1	1	2218257030	Lid
1109	2	2	2	51280308U0	B.H. Tapped Screw B, 3x8
1110	2	2	2	51280308U0	B.H. Tapped Screw B, 3x8
1121	12	12	12	51280308U0	B.H. Tapped Screw, B3x8ST
1122	2	2	2	51280308U0	B.H. Tapped Screw, B3x8ST
1123	4	4	4	51280308U0	B.H. Tapped Screw, B3x8ST
1126	1	1	1	1455259090	Bushing
1127	1	1	1	1455259040	Bushing
1131	8	8	8	51280306U0	B.H. Tapped Screw B, 3x6
1132	1	1	1	62040029W0	Lug
1202	10	10	10	62030049W0	Lug
1203	10	10	10	51280306B0	B.H. Tapped Screw, B3x6ST
1302	1	1	1	2218265010	Indicator
1303	1	1	1	2218265020	Indicator
1304	1	1	1	2218265030	Indicator
1310	2	2	2	51280306U0	B.H. Tapped Screw B, 3x6
1311	1	1	1	2911861170	Label, Do not use as handle.
1312	1	1	1	2506265060	Label, Do not use as handle.
1314	1	1	1	2911861110	Label
1315	1	1	1	2911861140	Label
1317	1	1	1	2578861010	Label, UL Caution
1318	1	1	1	2932861010	Label, Do not remove...
1321	1	1	1	9510911010	Label, LL No.
1322	1	1	1	9510911020	Label, UL Factory
1323	1	1	1	9511101020	Label, UL
1327	1	1	1	2911861310	Label, Fuse Caution
1328	1	1	1	2911861010	Label
1329	1	1	1	2911861190	Label
1404	1	1	1	2218851010	Instructions, Set
1406	1	1	1	2218851310	Instructions, Set
1409	1	1	1	2886851100	Instructions, Flysheet
1416	1	1	1	2218856010	Schematic Diagram
1422	1	1	1	2886861010	Label, On Power Transformer
1424	1	1	1	9510221010	Label, Fuse Caution
1425	1	1	1	2911861160	Label, Fuse Caution
1504	1	1	1	2577813010	Envelope
1505	1	1	1	2918813012	Envelope
1506	1	1	1	2818813010	Envelope
1511	1	1	1	2577851020	Instructions, Important
1512	1	1	1	2818851120	Instructions, Important
1516	1	1	1	2577854012	Guarantee Card
1517	1	1	1	9630000180	Guarantee Card
1521	1	1	1	9650000050	Service Station Card

REF. DESIG.	Q'TY			PART NO.	DESCRIPTION
	U	C	E		
1525	1	1	1	2818854023	Guarantee Card
1526	1	1	1	2818854042	Guarantee Card
1532	1	1	1	2818851040	Instructions, Packing
1533	1	1	1	2818851140	Instructions, Packing
1602	1	1	1	2218801010	Packing Case, Inner
1603	1	1	1	2218801110	Packing Case, Outer
1611	2	2	2	2219809010	Cushion
1616	1	1	1	9015555500	Polyethylene Bag, Set
1618	1	1	1	9013025010	Polyethylene Bag, Printed Matter
1619	1	1	1	9013025010	Polyethylene Bag, Accessories
1623	1	1	1	2864804010	Sleeve, AC Cord
1624	1	1	1	9560000042	Hang Tag
1626	1	1	1	2731821010	Silicagel
1628	1	1	1	2819056010	Buffer, AM Antenna
1702	4	4	4	9522815010	Serial No. Card
1703	4	4	4	9523015120	Serial No. Card
1704	4	4	4	9523015110	Serial No. Card
1714	2	2	2	9510901020	Label
1727	1	1	1	ZA02000070	External Antenna
FM FRONT END CIRCUIT BOARD - P100					
P100	1	1	1	YD22180020	P.W. Board (Print Only)
	1	1	1	AV01202080	FM Front End Assembly
P100 - RESISTORS					
R101	1	1	1	GD05473140	Fixed, 47kΩ ±5%, ¼W
R102	1	1	1	GD05123140	Fixed, 12kΩ ±5%, ¼W
R103	1	1	1	GD05473140	Fixed, 47kΩ ±5%, ¼W
R104	1	1	1	GD05223140	Fixed, 22kΩ ±5%, ¼W
R105	1	1	1	GD05101140	Fixed, 100Ω ±5%, ¼W
R106	1	1	1	GD05101140	Fixed, 100Ω ±5%, ¼W
R107	1	1	1	GD05182140	Fixed, 1.8kΩ ±5%, ¼W
R108	1	1	1	GD05473140	Fixed, 47kΩ ±5%, ¼W
R109	1	1	1	GD05123140	Fixed, 12kΩ ±5%, ¼W
R110	1	1	1	GD05473140	Fixed, 47kΩ ±5%, ¼W
R111	1	1	1	GD05101140	Fixed, 100Ω ±5%, ¼W
R112	1	1	1	GD05101140	Fixed, 100Ω ±5%, ¼W
R113	1	1	1	GD05473140	Fixed, 47kΩ ±5%, ¼W
R114	1	1	1	GD05561140	Fixed, 560Ω ±5%, ¼W
R115	1	1	1	GD05101140	Fixed, 100Ω ±5%, ¼W
R116	1	1	1	GD05331140	Fixed, 330Ω ±5%, ¼W
P100 - CAPACITORS					
C101	1	1	1	DD16150010	Ceramic, 15pF ±10%
C102	1	1	1	DD15470010	Ceramic, 47pF ±5%
C103	1	1	1	DD16101010	Ceramic, 100pF ±10%
C104	1	1	1	DK18203030	Ceramic, 0.02μF +80%, -20%
C105	1	1	1	DK18203030	Ceramic, 0.02μF +80%, -20%
C106	1	1	1	DK18203030	Ceramic, 0.02μF +80%, -20%
C107	1	1	1	DD16180020	Ceramic, 18pF ±10%
C108	1	1	1	DD16180020	Ceramic, 18pF ±10%
C109	1	1	1	DK18203030	Ceramic, 0.02μF +80%, -20%
C110	1	1	1	DK18203030	Ceramic, 0.02μF +80%, -20%
C111	1	1	1	DD16101010	Ceramic, 100pF ±10%
C112	1	1	1	DK18203030	Ceramic, 0.02μF +80%, -20%
C113	1	1	1	DK18203030	Ceramic, 0.02μF +80%, -20%
C114	1	1	1	DD12100010	Ceramic, 10pF ±10%
C115	1	1	1	DD16180020	Ceramic, 18pF ±10%
C116	1	1	1	DK18203030	Ceramic, 0.02μF +80%, -20%
C117	1	1	1	DD11080010	Ceramic, 8pF ±0.5pF

U : For U.S.A.
 C : For Canada
 E : For Europe

REF. DESIG.	Q'TY			PART NO.	DESCRIPTION
	U	C	E		
C118	1	1	1	DD10010020	Ceramic, 1pF ±0.5pF
C119	1	1	1	DD16150090	Ceramic, 15pF ±10%
C120	1	1	1	DD12100090	Ceramic, 10pF ±10%
C121	1	1	1	DK18203030	Ceramic, 0.02μF +80%, -20%
C122	1	1	1	CA53700010	Variable, FM-5, AM-3
C123	1	1	1	CT10500030	Trimmer, 3pF~8pF
P100 - MISCELLANEOUS					
Q101	1	1	1	HF400591A0	FET, 3SK59
Q102	1	1	1	HF400591A0	FET, 3SK59
Q103	1	1	1	HF400591A0	FET, 3SK59
Q104	1	1	1	HC10029050	IC, TA7301P
L105	1	1	1	LI71016060	IFT, FM
J101	1	1	1	YJ06001150	Plug
J102	1	1	1	YJ06001150	Plug
J103	1	1	1	YP10001510	Plug
J104	1	1	1	YP10001510	Plug
J105	1	1	1	YP10001510	Plug
AM TUNER, FM IF & MPX STEREO DECODER CIRCUIT BOARD - P200					
P200	1	1	1	YD22182060	P.W. Board (Print Only)
	1	1	1	ZZ22182060	P.W. Board Assembly
	1	1	1	ZZ22188060	P.W. Board Assembly
P200 - RESISTORS-(A)					
R151	1	1	1	RT05201140	Fixed, 200Ω ±5%, ¼W
R152	1	1	1	RT05302140	Fixed, 3kΩ ±5%, ¼W
R153	1	1	1	RT05103140	Fixed, 10kΩ ±5%, ¼W
R154	1	1	1	RT05103140	Fixed, 10kΩ ±5%, ¼W
R155	1	1	1	RT05301140	Fixed, 300Ω ±5%, ¼W
R156	1	1	1	RT05102140	Fixed, 1kΩ ±5%, ¼W
R157	1	1	1	RT05204140	Fixed, 200kΩ ±5%, ¼W
R158	1	1	1	RT05473140	Fixed, 47kΩ ±5%, ¼W
R159	1	1	1	RT05102140	Fixed, 1kΩ ±5%, ¼W
R160	1	1	1	RT05332140	Fixed, 3.3kΩ ±5%, ¼W
R161	1	1	1	RT05104140	Fixed, 100kΩ ±5%, ¼W
R162	1	1	1	RT05101140	Fixed, 100Ω ±5%, ¼W
R163	1	1	1	RA01030250	Semifixed, 10kΩ
R165	1	1	1	RT05101140	Fixed, 100Ω ±5%, ¼W
R166	1	1	1	RT05101140	Fixed, 100Ω ±5%, ¼W
P200 - CAPACITORS-(A)					
C151	1	1	1	DF17103010	Film, 0.01μF ±20%
C152	1	1	1	DF17102010	Film, 0.001μF ±20%
C153	1	1	1	DF17103010	Film, 0.01μF ±20%
C155	1	1	1	DF17103010	Film, 0.01μF ±20%
C156	1	1	1	DF65391010	Film, 390pF ±5%
C157	1	1	1	DF17403010	Film, 0.04μF ±20%
C158	1	1	1	DD16101010	Ceramic, 100pF ±10%
C159	1	1	1	DF17403010	Film, 0.04μF ±20%
C160	1	1	1	DK17102010	Ceramic, 0.001μF ±20%
C161	1	1	1	EA47503590	Electrolytic, 47μF, 35V
C162	1	1	1	EA33505090	Electrolytic, 3.3μF, 50V
C163	1	1	1	DF17473010	Film, 0.047μF ±20%
C164	1	1	1	DF17103010	Film, 0.01μF ±20%
C165	1	1	1	DK17103010	Ceramic, 0.01μF ±20%
C166	1	1	1	EV10403560	Electrolytic, 0.1μF, 35V
C167	1	1	1	EV10503560	Electrolytic, 1μF, 35V
C168	1	1	1	DK17502010	Ceramic, 0.005μF ±20%
C169	1	1	1	EA10701690	Electrolytic, 100μF, 16V

REF. DESIG.	Q'TY			PART NO.	DESCRIPTION
	U	C	E		
C170	1	1	1	DK18403020	Ceramic, 0.04μF +80%, -20%
C171	1	1	1	DK18403020	Ceramic, 0.04μF +80%, -20%
C172	1	1	1	EA10701690	Electrolytic, 100μF, 16V
P200 - SEMICONDUCTORS, COILS, TRANSFORMERS & FILTER-(A)					
Q151	1	1	1	HC10019010	IC, HA1197
Q152	1	1	1	HT313272A0	Transistor, 2SC1327 S or T
L151	1	1	1	LA10010190	RF Coil
L152	1	1	1	LO10010480	OSC Coil
L153	1	1	1	LI10015010	IFT, AM
L154	1	1	1	LI10015060	IFT, AM
L155	1	1	1	LC13320020	Choke Coil
F151	1	1	1	FF10045160	Ceramic Filter, 455 kHz
P200 - RESISTORS-(B)					
R201	1	1	1	RT05331140	Fixed, 330Ω ±5%, ¼W
R202	1	1	1	RT05331140	Fixed, 330Ω ±5%, ¼W
R203	1	1	1	RT05153140	Fixed, 15kΩ ±5%, ¼W
R204	1	1	1	RT05202140	Fixed, 2kΩ ±5%, ¼W
R205	1	1	1	RT05331140	Fixed, 330Ω ±5%, ¼W
R206	1	1	1	RT05201140	Fixed, 200Ω ±5%, ¼W
R207	1	1	1	RT05101140	Fixed, 100Ω ±5%, ¼W
R208	1	1	1	RT05331140	Fixed, 330Ω ±5%, ¼W
R209	1	1	1	RT05331140	Fixed, 330Ω ±5%, ¼W
R210	1	1	1	RT05101140	Fixed, 100Ω ±5%, ¼W
R211	1	1	1	RT05100140	Fixed, 10Ω ±5%, ¼W
R212	1	1	1	RT05151140	Fixed, 150Ω ±5%, ¼W
R213	1	1	1	RT05153140	Fixed, 15kΩ ±5%, ¼W
R214	1	1	1	RT05472140	Fixed, 4.7kΩ ±5%, ¼W
R215	1	1	1	RT05202140	Fixed, 2kΩ ±5%, ¼W
R216	1	1	1	RT05102140	Fixed, 1kΩ ±5%, ¼W
R217	1	1	1	RT05302140	Fixed, 3kΩ ±5%, ¼W
R218	1	1	1	RT05102140	Fixed, 1kΩ ±5%, ¼W
R219	1	1	1	RT05223140	Fixed, 22kΩ ±5%, ¼W
R220	1	1	1	RT05102140	Fixed, 1kΩ ±5%, ¼W
R221	1	1	1	RT05273140	Fixed, 27kΩ ±5%, ¼W
R222	1	1	1	RT05104140	Fixed, 100kΩ ±5%, ¼W
R223	1	1	1	RT05471140	Fixed, 470Ω ±5%, ¼W
R224	1	1	1	RT05102140	Fixed, 1kΩ ±5%, ¼W
R225	1	1	1	RT05202140	Fixed, 2kΩ ±5%, ¼W
R226	1	1	1	RT05152140	Fixed, 1.5kΩ ±5%, ¼W
R227	1	1	1	RT05101140	Fixed, 100Ω ±5%, ¼W
R228	1	1	1	RT05151140	Fixed, 150Ω ±5%, ¼W
R229	1	1	1	RT05271140	Fixed, 270Ω ±5%, ¼W
R230	1	1	1	RT05102140	Fixed, 1kΩ ±5%, ¼W
R231	1	1	1	RT05471140	Fixed, 470Ω ±5%, ¼W
R232	1	1	1	RT05153140	Fixed, 15kΩ ±5%, ¼W
R233	1	1	1	RT05472140	Fixed, 4.7kΩ ±5%, ¼W
R234	1	1	1	RT05152140	Fixed, 1.5kΩ ±5%, ¼W
R235	1	1	1	RT05102140	Fixed, 1kΩ ±5%, ¼W
R236	1	1	1	RT05273140	Fixed, 27kΩ ±5%, ¼W
R237	1	1	1	RT05473140	Fixed, 47kΩ ±5%, ¼W
R238	1	1	1	RT05331140	Fixed, 330Ω ±5%, ¼W
R239	1	1	1	RT05331140	Fixed, 330Ω ±5%, ¼W
R240	1	1	1	RT05102140	Fixed, 1kΩ ±5%, ¼W
R241	1	1	1	RT05181140	Fixed, 180Ω ±5%, ¼W
R242	1	1	1	RT05101140	Fixed, 100Ω ±5%, ¼W
R243	1	1	1	RT05101140	Fixed, 100Ω ±5%, ¼W
R244	1	1	1	RT05561140	Fixed, 560Ω ±5%, ¼W
R245	1	1	1	RT05153140	Fixed, 15kΩ ±5%, ¼W

U : For U.S.A.
C : For Canada
E : For Europe

REF. DESIG.	Q'TY			PART NO.	DESCRIPTION
	U	C	E		
R246	1	1	1	RT05472140	Fixed, 4.7kΩ ±5%, ¼W
R247	1	1	1	RT05102140	Fixed, 1kΩ ±5%, ¼W
R248	1	1	1	RT05102140	Fixed, 1kΩ ±5%, ¼W
R249	1	1	1	RT05273140	Fixed, 27kΩ ±5%, ¼W
R250	1	1	1	RT05151140	Fixed, 150Ω ±5%, ¼W
R251	1	1	1	RT05153140	Fixed, 15kΩ ±5%, ¼W
R252	1	1	1	RT05822140	Fixed, 8.2kΩ ±5%, ¼W
R253	1	1	1	RT05102140	Fixed, 1kΩ ±5%, ¼W
R254	1	1	1	RT05821140	Fixed, 820Ω ±5%, ¼W
R255	1	1	1	RT05821140	Fixed, 820Ω ±5%, ¼W
R256	1	1	1	RT05682140	Fixed, 6.8kΩ ±5%, ¼W
R257	1	1	1	RT05682140	Fixed, 6.8kΩ ±5%, ¼W
R258	1	1	1	RT05101140	Fixed, 100Ω ±5%, ¼W
R259	1	1	1	RT05562140	Fixed, 5.6kΩ ±5%, ¼W
R260	1	1	1	RT05105140	Fixed, 1MΩ ±5%, ¼W
R261	1	1	1	RT05224140	Fixed, 220kΩ ±5%, ¼W
R262	1	1	1	RT05223140	Fixed, 22kΩ ±5%, ¼W
R263	1	1	1	RT05122140	Fixed, 1.2kΩ ±5%, ¼W
R264	1	1	1	RT05222140	Fixed, 2.2kΩ ±5%, ¼W
R265	1	1	1	RT05561140	Fixed, 560Ω ±5%, ¼W
R266	1	1	1	RT05103140	Fixed, 10kΩ ±5%, ¼W
R267	1	1	1	RT05103140	Fixed, 10kΩ ±5%, ¼W
R268	1	1	1	RT05564140	Fixed, 560kΩ ±5%, ¼W
R269	1	1	1	RT05183140	Fixed, 18kΩ ±5%, ¼W
R270	1	1	1	RT05564140	Fixed, 560kΩ ±5%, ¼W
R271	1	1	1	RT05183140	Fixed, 18kΩ ±5%, ¼W
R272	1	1	1	RT05221140	Fixed, 220Ω ±5%, ¼W
R273	1	1	1	RT05101140	Fixed, 100Ω ±5%, ¼W
R274	1	1	1	RT05101140	Fixed, 100Ω ±5%, ¼W
R275	1	1	1	RT05683140	Fixed, 68kΩ ±5%, ¼W
R276	1	1	1	RT05473140	Fixed, 47kΩ ±5%, ¼W
R277	1	1	1	RT05153140	Fixed, 15kΩ ±5%, ¼W
R278	1	1	1	RA01030250	Semifixed, 10kΩ
R279	1	1	1	RT05102140	Fixed, 1kΩ ±5%, ¼W
R282	1	1	1	RT05153140	Fixed, 15kΩ ±5%, ¼W
P200 - CAPACITORS-(B)					
C201	1	1	1	DK17103010	Ceramic, 0.01μF±20%
C202	1	1	1	DK17103010	Ceramic, 0.01μF±20%
C203	1	1	1	DK17103010	Ceramic, 0.01μF±20%
C204	1	1	1	DK17103010	Ceramic, 0.01μF±20%
C205	1	1	1	DK18403020	Ceramic, 0.04μF +80%, -20%
C206	1	1	1	DK18403020	Ceramic, 0.04μF +80%, -20%
C207	1	1	1	DK17103010	Ceramic, 0.01μF±20%
C208	1	1	1	DK18403020	Ceramic, 0.04μF +80%, -20%
C209	1	1	1	DK18403020	Ceramic, 0.04μF +80%, -20%
C210	1	1	1	DK17103010	Ceramic, 0.01μF±20%
C211	1	1	1	DK17103010	Ceramic, 0.01μF±20%
C212	1	1	1	DK17103010	Ceramic, 0.01μF±20%
C213	1	1	1	DK18403020	Ceramic, 0.04μF +80%, -20%
C214	1	1	1	DK18403020	Ceramic, 0.04μF +80%, -20%
C215	1	1	1	DK17103010	Ceramic, 0.01μF±20%
C216	1	1	1	DK17103010	Ceramic, 0.01μF±20%
C217	1	1	1	DK17103010	Ceramic, 0.01μF±20%
C218	1	1	1	DD16201010	Ceramic, 200pF ±10%
C219	1	1	1	DD16201010	Ceramic, 200pF ±10%
C220	1	1	1	DK17103010	Ceramic, 0.01μF±20%
C221	1	1	1	DK18403020	Ceramic, 0.04μF +80%, -20%
C222	1	1	1	DK18403020	Ceramic, 0.04μF +80%, -20%
C223	1	1	1	EV22403560	Electrolytic, 0.22μF, 35V
C224	1	1	1	DD16201010	Ceramic, 200pF ±10%
C225	1	1	1	DD16201010	Ceramic, 200pF ±10%
C226	1	1	1	DK17103010	Ceramic, 0.01μF±20%
C227	1	1	1	DK18403020	Ceramic, 0.04μF +80%, -20%

REF. DESIG.	Q'TY			PART NO.	DESCRIPTION
	U	C	E		
C228	1	1	1	DD16201010	Ceramic, 200pF ±10%
C229	1	1	1	DD16201010	Ceramic, 200pF ±10%
C230	1	1	1	DD16201010	Ceramic, 200pF ±10%
C231	1	1	1	DK17103010	Ceramic, 0.01μF±20%
C232	1	1	1	DD16201010	Ceramic, 200pF ±10%
C233	1	1	1	DD16201010	Ceramic, 200pF ±10%
C234	1	1	1	DK17103010	Ceramic, 0.01μF±20%
C235	1	1	1	DK17103010	Ceramic, 0.01μF±20%
C236	1	1	1	DK18403020	Ceramic, 0.04μF +80%, -20%
C237	1	1	1	DK18403020	Ceramic, 0.04μF +80%, -20%
C238	1	1	1	DK18403020	Ceramic, 0.04μF +80%, -20%
C239	1	1	1	DK17103010	Ceramic, 0.01μF±20%
C240	1	1	1	DK17103010	Ceramic, 0.01μF±20%
C241	1	1	1	DK18403020	Ceramic, 0.04μF +80%, -20%
C242	1	1	1	DK18403020	Ceramic, 0.04μF +80%, -20%
C243	1	1	1	DD16201010	Ceramic, 200pF ±10%
C244	1	1	1	DD16201010	Ceramic, 200pF ±10%
C245	1	1	1	EA47601690	Electrolytic, 47μF, 16V
C246	1	1	1	EA10505090	Electrolytic, 1μF, 50V
C247	1	1	1	DD16201010	Ceramic, 200pF ±10%
C248	1	1	1	EA22601690	Electrolytic, 22μF, 16V
C249	1	1	1	EA47601690	Electrolytic, 47μF, 16V
C250	1	1	1	EA10701690	Electrolytic, 100μF, 16V
C251	1	1	1	DK18403010	Ceramic, 0.04μF +80%, -20%
C252	1	1	1	EA47601690	Electrolytic, 47μF, 16V
C253	1	1	1	EA10601690	Electrolytic, 10μF, 16V
C254	1	1	1	EA10601690	Electrolytic, 10μF, 16V
C255	1	1	1	EA10601690	Electrolytic, 10μF, 16V
C256	1	1	1	CT15000010	Trimmer, 50pF
C257	1	1	1	CT15000010	Trimmer, 50pF
C258	1	1	1	CT15000010	Trimmer, 50pF
C259	1	1	1	CT15000010	Trimmer, 50pF
C260	1	1	1	CT15000010	Trimmer, 50pF
C261	1	1	1	DK18403020	Ceramic, 0.04μF +80%, -20%
C262	1	1	1	DK18403020	Ceramic, 0.04μF +80%, -20%
P200 - SEMICONDUCTORS, COILS, TRANSFORMERS & FILTERS-(B)					
Q201	1	1	1	HT310471C0	Transistor, 2SC1047 (C)
Q202	1	1	1	HC10011060	IC, μPC555H
Q203	1	1	1	HC10019030	IC, LA1222
Q204	1	1	1	HT308291C0	Transistor, 2SC829 (C)
Q205	1	1	1	HC10019030	IC, LA1222
Q206	1	1	1	HT308291C0	Transistor, 2SC829 (C)
Q207	1	1	1	HD20011050	Diode, 1S1555
Q208	1	1	1	HD20011050	Diode, 1S1555
Q209	1	1	1	HT313272A0	Transistor, 2SC1327 S or T
Q210	1	1	1	HT108422A0	Transistor, 2SA842 G R or BL
Q211	1	1	1	HT308291C0	Transistor, 2SC829 (C)
Q212	1	1	1	HD10003020	Diode, 20A90
Q213	1	1	1	HD10003020	Diode, 20A90
Q214	1	1	1	HD10003020	Diode, 20A90
Q215	1	1	1	HD10003020	Diode, 20A90
Q216	1	1	1	HT308291C0	Transistor, 2SC829 (C)
Q217	1	1	1	HD10003020	Diode, 20A90
Q218	1	1	1	HD10003020	Diode, 20A90
Q219	1	1	1	HT308291C0	Transistor, 2SC829 (C)
Q220	1	1	1	HD10003020	Diode, 20A90
Q221	1	1	1	HD10003020	Diode, 20A90
Q222	1	1	1	HT309452B0	Transistor, 2SC945 J or P
Q223	1	1	1	HD10003020	Diode, 20A90

U : For U.S.A.
 C : For Canada
 E : For Europe

REF. DESIG.	Q'TY			PART NO.	DESCRIPTION
	U	C	E		
L201	1	1	1	LI14016230	IFT, FM (Detector)
L202	1	1	1	LC12230020	Choke Coil, 22μH
L203	1	1	1	LC12230020	Choke Coil, 22μH
L204	1	1	1	LC13320020	Choke Coil, 3.3μH
L205	1	1	1	LC13320020	Choke Coil, 3.3μH
L206	1	1	1	LC13320020	Choke Coil, 3.3μH
F201	1	1	1	FF11070050	Ceramic Filter, 10.7MHz
F202	1	1	1	FF11070050	Ceramic Filter, 10.7MHz
F203	1	1	1	FF11070050	Ceramic Filter, 10.7MHz
F204	1	1	1	FF11070050	Ceramic Filter, 10.7MHz
F205	1	1	1	FF11070050	Ceramic Filter, 10.7MHz
P200 - RESISTORS-(C)					
R301	1	1	1	RT05272140	Fixed, 2.7kΩ ±5%, ¼W
R302	1	1	1	RT05272140	Fixed, 2.7kΩ ±5%, ¼W
R303	1	1	1	RT05102140	Fixed, 1kΩ ±5%, ¼W
R304	1	1	1	RT05392140	Fixed, 3.9kΩ ±5%, ¼W
R305	1	1	1	RT05392140	Fixed, 3.9kΩ ±5%, ¼W
R306	1	1	1	RT05102140	Fixed, 1kΩ ±5%, ¼W
R307	1	1	1	RT05102140	Fixed, 1kΩ ±5%, ¼W
R308	1	1	1	RT05101140	Fixed, 100Ω ±5%, ¼W
R309	1	1	1	RT05163140	Fixed, 16kΩ ±5%, ¼W
R310	1	1	1	RA04720050	Semifixed, 4.7kΩ
R311	1	1	1	RT05272140	Fixed, 2.7kΩ ±5%, ¼W
R312	1	1	1	RT05512140	Fixed, 5.1kΩ ±5%, ¼W
R313	1	1	1	RT05512140	Fixed, 5.1kΩ ±5%, ¼W
R314	1	1	1	RT05202140	Fixed, 2.0kΩ ±5%, ¼W
R315	1	1	1	RT05202140	Fixed, 2.0kΩ ±5%, ¼W
R316	1	1	1	RT05332140	Fixed, 3.3kΩ ±5%, ¼W
R317	1	1	1	RT05332140	Fixed, 3.3kΩ ±5%, ¼W
R318	1	1	1	RT05103140	Fixed, 10kΩ ±5%, ¼W
R319	1	1	1	RA05030120	Semifixed, 50kΩ
R320	1	1	1	RT05204140	Fixed, 200kΩ ±5%, ¼W
R321	1	1	1	RT05303140	Fixed, 30kΩ ±5%, ¼W
R322	1	1	1	RT05103140	Fixed, 10kΩ ±5%, ¼W
R323	1	1	1	RT05103140	Fixed, 10kΩ ±5%, ¼W
R324	1	1	1	RT05101140	Fixed, 100Ω ±5%, ¼W
R325	1	1	1	RT05273140	Fixed, 27kΩ ±5%, ¼W
R326	1	1	1	RT05273140	Fixed, 27kΩ ±5%, ¼W
R327	1	1	1	RT05104140	Fixed, 100kΩ ±5%, ¼W
R328	1	1	1	RT05104140	Fixed, 100kΩ ±5%, ¼W
R329	1	1	1	RT05222140	Fixed, 2.2kΩ ±5%, ¼W
R330	1	1	1	RA01030250	Semifixed, 10kΩ
R331	1	1	1	RT05104140	Fixed, 100kΩ ±5%, ¼W
R332	1	1	1	RT05104140	Fixed, 100kΩ ±5%, ¼W
R333	1	1	1	RT05102140	Fixed, 1kΩ ±5%, ¼W
R334	1	1	1	RA01040180	Semifixed, 100kΩ
R335	1	1	1	RT05104140	Fixed, 100kΩ ±5%, ¼W
R336	1	1	1	RT05103140	Fixed, 10kΩ ±5%, ¼W
R337	1	1	1	RT05332140	Fixed, 3.3kΩ ±5%, ¼W
R338	1	1	1	RT05564140	Fixed, 560kΩ ±5%, ¼W
R339	1	1	1	RT05333140	Fixed, 33kΩ ±5%, ¼W
R340	1	1	1	RT05101140	Fixed, 100Ω ±5%, ¼W
R341	1	1	1	RT05154140	Fixed, 150kΩ ±5%, ¼W
R342	1	1	1	RT05473140	Fixed, 47kΩ ±5%, ¼W
R343	1	1	1	RT05224140	Fixed, 220kΩ ±5%, ¼W
R344	1	1	1	RT05104140	Fixed, 100kΩ ±5%, ¼W
R345	1	1	1	RT05103140	Fixed, 10kΩ ±5%, ¼W
R346	1	1	1	RT05101140	Fixed, 100Ω ±5%, ¼W
R347	1	1	1	RA01040180	Semifixed, 100kΩ
R348	1	1	1	RT05183140	Fixed, 18kΩ ±5%, ¼W
P200 - CAPACITORS-(C)					
C311	1	1	1	DF15562050	Film, 5600pF ±5%

REF. DESIG.	Q'TY			PART NO.	DESCRIPTION
	U	C	E		
C312	1	1	1	DF15562050	Film, 5600pF ±5%
C301	1	1	1	DF55471010	Film, 470pF ±5%
C302	1	1	1	DF55911010	Film, 910pF ±5%
C303	1	1	1	DF55681010	Film, 680pF ±5%
C304	1	1	1	DF55152030	Film, 1500pF ±5%
C305	1	1	1	EA22601690	Electrolytic, 22μF, 16V
C306	1	1	1	DF17473010	Film, 0.047μF ±20%
C307	1	1	1	EQ22405010	Electrolytic, 0.22μF ±20%
C308	1	1	1	EQ47405010	Electrolytic, 0.47μF ±20%
C309	1	1	1	EQ22405010	Electrolytic, 0.22μF ±20%
C310	1	1	1	DF55471010	Film, 470pF ±5%
C311	1	1	1	DF15272050	Film, 2700pF ±5%
C312	1	1	1	DF15272050	Film, 2700pF ±5%
C313	1	1	1	DF15562050	Film, 5600pF ±5%
C314	1	1	1	DF15562050	Film, 5600pF ±5%
C315	1	1	1	EA10601690	Electrolytic, 10μF, 16V
C316	1	1	1	EA10601690	Electrolytic, 10μF, 16V
C317	1	1	1	EA10701690	Electrolytic, 100μF, 16V
C318	1	1	1	EA10701690	Electrolytic, 0.1μF, 35V
C319	1	1	1	EV10403560	Electrolytic, 0.1μF, 35V
C320	1	1	1	EV10503560	Electrolytic, 1μF, 35V
C321	1	1	1	EV10503560	Electrolytic, 1μF, 35V
C322	1	1	1	EV10503560	Electrolytic, 1μF, 35V
P200 - SEMICONDUCTORS & COILS-(C)					
Q301	1	1	1	HC10004010	IC, HA1156
Q302	1	1	1	HT108422A0	Transistor, 2SA842 GR or BL
Q303	1	1	1	HT108422A0	Transistor, 2SA842 GR or BL
Q304	1	1	1	HT309452B0	Transistor, 2SC945 Q or P
Q305	1	1	1	HT107331Q0	Transistor, 2SA733 Q
Q306	1	1	1	HF200300A0	FET, 2SK30
Q307	1	1	1	HT309452B0	Transistor, 2SC945 Q or P
Q308	1	1	1	HT309452B0	Transistor, 2SC945 Q or P
Q309	1	1	1	HT309452B0	Transistor, 2SC945 Q or P
Q310	1	1	1	HT309452B0	Transistor, 2SC945 Q or P
Q311	1	1	1	HT309452B0	Transistor, 2SC945 Q or P
Q312	1	1	1	HT309452B0	Transistor, 2SC945 Q or P
Q313	1	1	1	HD20011050	Diode, 1S1555
L301	1	1	1	LS10290160	Antibirde Coil
L302	1	1	1	LS10290170	Antibirde Coil
L303	1	1	1	LS10290180	Antibirde Coil
L304	1	1	1	LS35035010	LPF Coil
P200 - MISCELLANEOUS					
P208	12	12	12	2933118020	Spacer
P211	12	12	12	75061251P0	Jumper Wire
J201	1	1	1	YP10001130	Plug
J202	1	1	1	YP10001130	Plug
J203	1	1	1	YP10001130	Plug
J204	1	1	1	YP10001130	Plug
J205	1	1	1	YP10001130	Plug
J206	1	1	1	YP06000570	Plug
J207	1	1	1	YP06000570	Plug
J209	1	1	1	YP10001130	Plug
J210	1	1	1	YP10001130	Plug
J211	1	1	1	YP10001130	Plug
J212	1	1	1	YP10001130	Plug
J213	1	1	1	YP10001130	Plug
J216	1	1	1	YP10001130	Plug
J217	1	1	1	YP10001130	Plug
J218	1	1	1	YP06000570	Plug
J221	1	1	1	YP10001130	Plug

U : For U.S.A.
C : For Canada
E : For Europe

REF. DESIG.	Q'TY			PART NO.	DESCRIPTION
	U	C	E		
J223 ? J234	12	12	12	YP10001130	Plug
J235	1	1	1	YP06000570	Plug
J236	1	1	1	YP10001130	Plug
J238	1	1	1	YP10001130	Plug
J239	1	1	1	YP10001130	Plug
J240	1	1	1	YP10001130	Plug
FM NOISE AMP CIRCUIT BOARD - PB00					
PB00	1	1	1	YA22180610	P.W. Board (Print Only)
	1	1	1	ZZ22180610	P.W. Board Assembly
PB00 - RESISTORS					
RB01	1	1	1	RT05562140	Fixed, 5.6kΩ ±5%, ¼W
RB02	1	1	1	RT05104140	Fixed, 100kΩ ±5%, ¼W
RB03	1	1	1	RT05273140	Fixed, 27kΩ ±5%, ¼W
RB04	1	1	1	RT05102140	Fixed, 1kΩ ±5%, ¼W
RB05	1	1	1	RT05273140	Fixed, 27kΩ ±5%, ¼W
RB06	1	1	1	RT05333140	Fixed, 33kΩ ±5%, ¼W
RB07	1	1	1	RT05221140	Fixed, 220Ω ±5%, ¼W
RB08	1	1	1	RT05101140	Fixed, 100Ω ±5%, ¼W
RB09	1	1	1	RT05101140	Fixed, 100Ω ±5%, ¼W
PB00 - CAPACITORS					
CB01	1	1	1	DD12100010	Ceramic, 10pF
CB02	1	1	1	DF16683010	Film, 0.068μF
CB03	1	1	1	DF17403010	Film, 0.04μF
CB04	1	1	1	DK18104020	Ceramic, 0.1μF
CB05	1	1	1	DK18403020	Ceramic, 0.04μF
CB06	1	1	1	EA10601690	Electrolytic, 10μF, 16V
PB00 - MISCELLANEOUS					
QB01	1	1	1	HT308281D0	Transistor, 2SC828S
QB02	1	1	1	HT308281D0	Transistor, 2SC828S
QB03	1	1	1	HD10001050	Diode, 1N60
QB04	1	1	1	HD10001050	Diode, 1N60
L801	1	1	1	LC21050010	Choke Coil, 1mH
JB01 ? JB04	4	4	4	YP10001130	Plug
FM BUFFER AMP CIRCUIT BOARD - PC00					
PC00	1	1	1	YA22180220	P.W. Board (Print Only)
	1	1	1	ZZ22180220	P.W. Board Assembly
PC00 - RESISTORS					
RC01	1	1	1	RA05020200	Semifixed, 5kΩ
RC02	1	1	1	RA05020200	Semifixed, 5kΩ
RC03	1	1	1	RT05101140	Fixed, 100Ω ±5%, ¼W
RC04	1	1	1	RT05101140	Fixed, 100Ω ±5%, ¼W
RC05	1	1	1	RT05155140	Fixed, 1.5MΩ ±5%, ¼W
RC06	1	1	1	RT05155140	Fixed, 1.5MΩ ±5%, ¼W
RC07	1	1	1	RT05104140	Fixed, 100kΩ ±5%, ¼W
RC08	1	1	1	RT05104140	Fixed, 100kΩ ±5%, ¼W
RC09	1	1	1	RT05223140	Fixed, 22kΩ ±5%, ¼W
RC10	1	1	1	RT05223140	Fixed, 22kΩ ±5%, ¼W
RC11	1	1	1	RT05681140	Fixed, 680Ω ±5%, ¼W

REF. DESIG.	Q'TY			PART NO.	DESCRIPTION
	U	C	E		
RC12	1	1	1	RT05681140	Fixed, 680Ω ±5%, ¼W
RC13	1	1	1	RT05101140	Fixed, 100Ω ±5%, ¼W
RC14	1	1	1	RT05101140	Fixed, 100Ω ±5%, ¼W
RC15	1	1	1	RT05272140	Fixed, 2.7kΩ ±5%, ¼W
RC16	1	1	1	RT05272140	Fixed, 2.7kΩ ±5%, ¼W
RC17	1	1	1	RT05562140	Fixed, 5.6kΩ ±5%, ¼W
RC18	1	1	1	RT05562140	Fixed, 5.6kΩ ±5%, ¼W
RC19	1	1	1	RT05561140	Fixed, 560Ω ±5%, ¼W
RC20	1	1	1	RT05561140	Fixed, 560Ω ±5%, ¼W
RC21	1	1	1	RT05224140	Fixed, 220kΩ ±5%, ¼W
RC22	1	1	1	RT05224140	Fixed, 220kΩ ±5%, ¼W
RC23	1	1	1	RT05224140	Fixed, 220kΩ ±5%, ¼W
RC24	1	1	1	RT05224140	Fixed, 220kΩ ±5%, ¼W
RC25	1	1	1	RT05152140	Fixed, 1.5kΩ ±5%, ¼W
RC26	1	1	1	RT05152140	Fixed, 1.5kΩ ±5%, ¼W
RC27	1	1	1	RT05102140	Fixed, 1kΩ ±5%, ¼W
RC28	1	1	1	RT05102140	Fixed, 1kΩ ±5%, ¼W
PC00 - CAPACITORS					
CC01	1	1	1	EV47403560	Electrolytic, 0.47μF, 35V
CC02	1	1	1	EV47403560	Electrolytic, 0.47μF, 35V
CC03	1	1	1	EV10503560	Electrolytic, 1μF, 35V
CC04	1	1	1	EV10503560	Electrolytic, 1μF, 35V
CC05	1	1	1	EV10503560	Electrolytic, 1μF, 35V
CC06	1	1	1	EV10503560	Electrolytic, 1μF, 35V
CC07	1	1	1	EA22702590	Electrolytic, 220μF, 25V
CC08	1	1	1	EA47503590	Electrolytic, 4.7μF, 35V
PC00 - SEMICONDUCTORS					
QC01	1	1	1	HT313272A0	Transistor, 2SC1327S or T
QC02	1	1	1	HT313272A0	Transistor, 2SC1327S or T
QC03	1	1	1	HT108422A0	Transistor, 2SA842 GR or BL
QC04	1	1	1	HT108422A0	Transistor, 2SA842 GR or BL
QC05	1	1	1	HT309452B0	Transistor, 2SC945 P or Q
QC06	1	1	1	HD20011050	Diode, 1S1555
PC00 - MISCELLANEOUS					
PC08	4	4	4	2933118020	Spacer
PC11	3	3	3	75061251P0	Jumper Wire
LC01	1	1	1	LY20240120	Relay, 24V
JC01 ? JC14	14	14	14	YP10001130	Plug
PHONO AMP & SELECTOR SWITCH CIRCUIT BOARD - P400					
P400	1	1	1	YA22180250	P.W. Board (Print Only)
	1	1	1	ZZ22180250	P.W. Board Assembly
			1	ZZ22188250	P.W. Board Assembly
P400 - RESISTORS					
R401	1	1	1	RN05753140	Fixed, 75kΩ ±5%, ¼W
R402	1	1	1	RN05753140	Fixed, 75kΩ ±5%, ¼W
R403	1	1	1	RN05154140	Fixed, 150kΩ ±5%, ¼W
R404	1	1	1	RN05154140	Fixed, 150kΩ ±5%, ¼W
R405	1	1	1	RT05222140	Fixed, 2.2kΩ ±5%, ¼W
R406	1	1	1	RT05222140	Fixed, 2.2kΩ ±5%, ¼W
R407	1	1	1	RN05123140	Fixed, 12kΩ ±5%, ¼W
R408	1	1	1	RN05123140	Fixed, 12kΩ ±5%, ¼W
R409	1	1	1	RN05154140	Fixed, 150kΩ ±5%, ¼W
R410	1	1	1	RN05154140	Fixed, 150kΩ ±5%, ¼W
R411	1	1	1	RT05911140	Fixed, 910Ω ±5%, ¼W

U : For U.S.A.
 C : For Canada
 E : For Europe

REF. DESIG.	Q'TY			PART NO.	DESCRIPTION
	U	C	E		
R412	1	1	1	RT05911140	Fixed, 910Ω ±5%, ¼W
R413	1	1	1	RN05115140	Fixed, 1.1MΩ±5%, ¼W
R414	1	1	1	RN05115140	Fixed, 1.1MΩ±5%, ¼W
R415	1	1	1	RT05683140	Fixed, 68kΩ ±5%, ¼W
R416	1	1	1	RT05683140	Fixed, 68kΩ ±5%, ¼W
R417	1	1	1	RT05431140	Fixed, 430Ω ±5%, ¼W
R418	1	1	1	RT05431140	Fixed, 430Ω ±5%, ¼W
R419	1	1	1	RT05111140	Fixed, 110Ω ±5%, ¼W
R420	1	1	1	RT05111140	Fixed, 110Ω ±5%, ¼W
R421	1	1	1	RT05560140	Fixed, 56Ω ±5%, ¼W
R422	1	1	1	RT05560140	Fixed, 56Ω ±5%, ¼W
R423	1	1	1	RT05152140	Fixed, 1.5kΩ ±5%, ¼W
R424	1	1	1	RT05152140	Fixed, 1.5kΩ ±5%, ¼W
R425	1	1	1	RT05363140	Fixed, 36kΩ ±5%, ¼W
R426	1	1	1	RT05363140	Fixed, 36kΩ ±5%, ¼W
R427	1	1	1	RT05331140	Fixed, 330Ω ±5%, ¼W
R428	1	1	1	RT05331140	Fixed, 330Ω ±5%, ¼W
R429	1	1	1	RT05274140	Fixed, 270kΩ±5%, ¼W
R430	1	1	1	RT05274140	Fixed, 270kΩ±5%, ¼W
R431	1	1	1	GJ05331010	Fixed, 330Ω ±5%, 1W
R432	1	1	1	RT05223140	Fixed, 22kΩ ±5%, ¼W
R433	1	1	1	RT05104140	Fixed, 100kΩ±5%, ¼W
R434	1	1	1	RT05104140	Fixed, 100kΩ±5%, ¼W
R435	1	1	1	RT05222140	Fixed, 2.2kΩ ±5%, ¼W
R436	1	1	1	RT05222140	Fixed, 2.2kΩ ±5%, ¼W
R437	1	1	1	RT05222140	Fixed, 2.2kΩ ±5%, ¼W
P400 - CAPACITORS					
C401	1	1	1	EE47502510	Electrolytic, 4.7μF ±20%, 25V
C402	1	1	1	EE47502510	Electrolytic, 4.7μF ±20%, 25V
C403	1	1	1	DD15390010	Ceramic, 39pF ±5%, 50V
C404	1	1	1	DD15390010	Ceramic, 39pF ±5%, 50V
C405	1	1	1	DD15331010	Ceramic, 330pF±5%, 50V
C406	1	1	1	DD15331010	Ceramic, 330pF±5%, 50V
C407	1	1	1	DD15331010	Ceramic, 330pF±5%, 50V
C408	1	1	1	DD15331010	Ceramic, 330pF±5%, 50V
C409	1	1	1	EE33601040	Electrolytic, 33μF ±20%, 10V
C410	1	1	1	EE33601040	Electrolytic, 33μF ±20%, 10V
C411	1	1	1	DF15332010	Film, 3300pF±5%, 50V
C412	1	1	1	DF15332010	Film, 3300pF±5%, 50V
C413	1	1	1	DF15102010	Film, 1000pF±5%, 50V
C414	1	1	1	DF15102010	Film, 1000pF±5%, 50V
C415	1	1	1	DD11040010	Ceramic, 4pF ±0.5pF, 50V
C416	1	1	1	DD11040010	Ceramic, 4pF ±0.5pF, 50V
C417	1	1	1	EE47502510	Electrolytic, 4.7μF ±20%, 25V
C418	1	1	1	EE47502510	Electrolytic, 4.7μF ±20%, 25V
C419	1	1	1	DF16562010	Film, 5600pF±10%, 50V
C420	1	1	1	DF16562010	Film, 5600pF±10%, 50V
C421	1	1	1	DD15101010	Ceramic, 100pF±5%, 50V
C422	1	1	1	DD15101010	Ceramic, 100pF±5%, 50V
C423	1	1	1	DD15101010	Ceramic, 100pF±5%, 50V
C424	1	1	1	DD15101010	Ceramic, 100pF±5%, 50V
C425	1	1	1	EA10703590	Electrolytic, 100μF +100%, -10%, 35V
C426	1	1	1	EA10703590	Electrolytic, 100μF +100%, -10%, 35V
P400 - SEMICONDUCTORS					
Q401	1	1	1	HT108722D0	Transistor, 2SA872A D or E
Q402	1	1	1	HT108722D0	Transistor, 2SA872A D or E
Q403	1	1	1	HT108722D0	Transistor, 2SA872A D or E
Q404	1	1	1	HT108722D0	Transistor, 2SA872A D or E
Q405	1	1	1	HT317752E0	Transistor, 2SC1775A E or F
Q406	1	1	1	HT317752E0	Transistor, 2SC1775A E or F
Q407	1	1	1	HT108722E0	Transistor, 2SA872A E or F

REF. DESIG.	Q'TY			PART NO.	DESCRIPTION
	U	C	E		
Q408	1	1	1	HT108722E0	Transistor, 2SA872A E or F
Q409	1	1	1	HT309452A0	Transistor, 2SC945 Q or R
Q410	1	1	1	HT107332A0	Transistor, 2SA733 Q or R
Q411	1	1	1	HD20001210	Diode, 1S2473
Q412	1	1	1	HD20004130	Diode, S1B01-02
P400 - MISCELLANEOUS					
J401	1	1	1		
J414	14	14	14	YP06001040	Plug, 3P
J415	1	1	1	YJ06000460	Jack, 4P
J416	1	1	1	YJ06000740	Jack, 3P
J417	1	1	1	YP06001040	Plug, 3P
J418	1	1	1	YP06001040	Plug, 3P
S401	1	1	1	SR13060020	Rotary Switch, Selector
S401			1	SR11060020	Rotary Switch, Selector
S402	1	1	1	SR04050110	Rotary Switch, Mode
P410	14	14	14	75061251P0	Jumper Wire
P412			1	75060501P0	Jumper Wire
MAIN AMP & PEAK INDICATOR CIRCUIT BOARD - P700					
P700	1	1	1	YD22182080	P.W. Board (Print Only)
	1	1	1	ZZ22182080	P.W. Board Assembly
P700 - RESISTORS					
R701	1	1	1	RT05474140	Fixed, 470kΩ±5%, ¼W
R702	1	1	1	RT05474140	Fixed, 470kΩ±5%, ¼W
R703	1	1	1	RT05102140	Fixed, 1kΩ ±5%, ¼W
R704	1	1	1	RT05102140	Fixed, 1kΩ ±5%, ¼W
R705	1	1	1	RT05513140	Fixed, 51kΩ ±5%, ¼W
R706	1	1	1	RT05513140	Fixed, 51kΩ ±5%, ¼W
R707	1	1	1	RT05243140	Fixed, 24kΩ ±5%, ¼W
R708	1	1	1	RT05243140	Fixed, 24kΩ ±5%, ¼W
R709	1	1	1	RT05243140	Fixed, 24kΩ ±5%, ¼W
R710	1	1	1	RT05243140	Fixed, 24kΩ ±5%, ¼W
R711	1	1	1	RT05822140	Fixed, 8.2kΩ ±5%, ¼W
R712	1	1	1	RT05822140	Fixed, 8.2kΩ ±5%, ¼W
R713	1	1	1	RT05222140	Fixed, 2.2kΩ ±5%, ¼W
R714	1	1	1	RT05222140	Fixed, 2.2kΩ ±5%, ¼W
R715	1	1	1	RT05472140	Fixed, 4.7kΩ ±5%, ¼W
R716	1	1	1	RT05472140	Fixed, 4.7kΩ ±5%, ¼W
R717	1	1	1	RT05242140	Fixed, 2.4kΩ ±5%, ¼W
R718	1	1	1	RT05242140	Fixed, 2.4kΩ ±5%, ¼W
R719	1	1	1	RT05102140	Fixed, 1kΩ ±5%, ¼W
R720	1	1	1	RT05102140	Fixed, 1kΩ ±5%, ¼W
R721	1	1	1	RT05154140	Fixed, 150kΩ±5%, ¼W
R722	1	1	1	RT05154140	Fixed, 150kΩ±5%, ¼W
R723	1	1	1	RT05183140	Fixed, 18kΩ ±5%, ¼W
R724	1	1	1	RT05183140	Fixed, 18kΩ ±5%, ¼W
R725	1	1	1	RT05302140	Fixed, 3kΩ ±5%, ¼W
R726	1	1	1	RT05302140	Fixed, 3kΩ ±5%, ¼W
R727	1	1	1	RT05394140	Fixed, 390kΩ±5%, ¼W
R728	1	1	1	RT05394140	Fixed, 390kΩ±5%, ¼W
R729	1	1	1	RA02020130	Semifixed, 2kΩ (B)
R730	1	1	1	RA02020130	Semifixed, 2kΩ (B)
R731	1	1	1	RT05183140	Fixed, 18kΩ ±5%, ¼W
R732	1	1	1	RT05183140	Fixed, 18kΩ ±5%, ¼W
R733	1	1	1	GF05202140	Fixed, 2kΩ ±5%, ¼W
R734	1	1	1	GF05202140	Fixed, 2kΩ ±5%, ¼W

U : For U.S.A.
C : For Canada
E : For Europe

REF. DESIG.	Q'TY			PART NO.	DESCRIPTION
	U	C	E		
R735	1	1	1	GF05202140	Fixed, 2kΩ ±5%, ¼W
R736	1	1	1	GF05202140	Fixed, 2kΩ ±5%, ¼W
R737	1	1	1	GF05202140	Fixed, 2kΩ ±5%, ¼W
R738	1	1	1	GF05202140	Fixed, 2kΩ ±5%, ¼W
R739	1	1	1	GF05202140	Fixed, 2kΩ ±5%, ¼W
R740	1	1	1	GF05202140	Fixed, 2kΩ ±5%, ¼W
R741	1	1	1	GF05202140	Fixed, 2kΩ ±5%, ¼W
R742	1	1	1	GF05202140	Fixed, 2kΩ ±5%, ¼W
R743	1	1	1	GF05151140	Fixed, 150Ω ±5%, ¼W
R744	1	1	1	GF05151140	Fixed, 150Ω ±5%, ¼W
R745	1	1	1	GF05151140	Fixed, 150Ω ±5%, ¼W
R746	1	1	1	GF05151140	Fixed, 150Ω ±5%, ¼W
R747	1	1	1	RA01020200	Semifixed, 1kΩ (B)
R748	1	1	1	RA01020200	Semifixed, 1kΩ (B)
R749	1	1	1	RT05151140	Fixed, 150Ω ±5%, ¼W
R750	1	1	1	RT05151140	Fixed, 150Ω ±5%, ¼W
R751	1	1	1	GF05111140	Fixed, 110Ω ±5%, ¼W
R752	1	1	1	GF05111140	Fixed, 110Ω ±5%, ¼W
R753	1	1	1	RT05753140	Fixed, 75kΩ ±5%, ¼W
R754	1	1	1	RT05753140	Fixed, 75kΩ ±5%, ¼W
R755	1	1	1	GJ05100030	Fixed, 10Ω ±5%, 3W
R756	1	1	1	GJ05100030	Fixed, 10Ω ±5%, 3W
R757	1	1	1	GJ05010010	Fixed, 1Ω ±5%, 1W
R758	1	1	1	GJ05010010	Fixed, 1Ω ±5%, 1W
R759	1	1	1	GF05161140	Fixed, 160Ω ±5%, ¼W
R760	1	1	1	GF05161140	Fixed, 160Ω ±5%, ¼W
R761	1	1	1	RT05101140	Fixed, 100Ω ±5%, ¼W
R762	1	1	1	RT05101140	Fixed, 100Ω ±5%, ¼W
R763	1	1	1	GF05201140	Fixed, 200Ω ±5%, ¼W
R764	1	1	1	GF05201140	Fixed, 200Ω ±5%, ¼W
R765	1	1	1	GF05121140	Fixed, 120Ω ±5%, ¼W
R766	1	1	1	GF05121140	Fixed, 120Ω ±5%, ¼W
R767	1	1	1	GF05201140	Fixed, 200Ω ±5%, ¼W
R768	1	1	1	GF05201140	Fixed, 200Ω ±5%, ¼W
R769	1	1	1	RT05101140	Fixed, 100Ω ±5%, ¼W
R770	1	1	1	RT05101140	Fixed, 100Ω ±5%, ¼W
R771	1	1	1	RT05562140	Fixed, 5.6kΩ ±5%, ¼W
R772	1	1	1	RT05562140	Fixed, 5.6kΩ ±5%, ¼W
R773	1	1	1	RT05562140	Fixed, 5.6kΩ ±5%, ¼W
R774	1	1	1	RT05562140	Fixed, 5.6kΩ ±5%, ¼W
R775	1	1	1	RT05243140	Fixed, 24kΩ ±5%, ¼W
R776	1	1	1	RT05243140	Fixed, 24kΩ ±5%, ¼W
R777	1	1	1	GJ05022010	Fixed, 2.2Ω ±5%, 1W
R778	1	1	1	GJ05022010	Fixed, 2.2Ω ±5%, 1W
R779	1	1	1	GF05221120	Fixed, 220Ω ±5%, ½W
R780	1	1	1	GF05221120	Fixed, 220Ω ±5%, ½W
R781	1	1	1	GJ05022010	Fixed, 2.2Ω ±5%, 1W
R782	1	1	1	GJ05022010	Fixed, 2.2Ω ±5%, 1W
R783	1	1	1	GF05100140	Fixed, 10Ω ±5%, ¼W
R784	1	1	1	GF05100140	Fixed, 10Ω ±5%, ¼W
R785	1	1	1	GJ05022020	Fixed, 2.2Ω ±5%, 2W
R786	1	1	1	GJ05022020	Fixed, 2.2Ω ±5%, 2W
R787	1	1	1	GW10682050	Fixed, 0.68Ω ±10%, 5W
R788	1	1	1	GW10682050	Fixed, 0.68Ω ±10%, 5W
R789	1	1	1	GW10682050	Fixed, 0.68Ω ±10%, 5W
R790	1	1	1	GW10682050	Fixed, 0.68Ω ±10%, 5W
R791	1	1	1	GW10682050	Fixed, 0.68Ω ±10%, 5W
R792	1	1	1	GW10682050	Fixed, 0.68Ω ±10%, 5W
R793	1	1	1	GW10682050	Fixed, 0.68Ω ±10%, 5W
R794	1	1	1	GW10682050	Fixed, 0.68Ω ±10%, 5W
R795	1	1	1	GW10682050	Fixed, 0.68Ω ±10%, 5W
R796	1	1	1	GW10682050	Fixed, 0.68Ω ±10%, 5W
R797	1	1	1	GW10682050	Fixed, 0.68Ω ±10%, 5W

REF. DESIG.	Q'TY			PART NO.	DESCRIPTION
	U	C	E		
R798	1	1	1	GW10682050	Fixed, 0.68Ω ±10%, 5W
R799	1	1	1	GF05822140	Fixed, 8.2kΩ ±5%, ¼W
R800	1	1	1	GF05822140	Fixed, 8.2kΩ ±5%, ¼W
R801	1	1	1	RT05512140	Fixed, 5.1kΩ ±5%, ¼W
R802	1	1	1	RT05512140	Fixed, 5.1kΩ ±5%, ¼W
R803	1	1	1	RT05753140	Fixed, 75kΩ ±5%, ¼W
R804	1	1	1	RT05753140	Fixed, 75kΩ ±5%, ¼W
R805	1	1	1	GF05511140	Fixed, 510Ω ±5%, ¼W
R806	1	1	1	GF05511140	Fixed, 510Ω ±5%, ¼W
R807	1	1	1	GJ05682020	Fixed, 6.8kΩ ±5%, 2W
R808	1	1	1	GJ05682020	Fixed, 6.8kΩ ±5%, 2W
R809	1	1	1	RT05223140	Fixed, 22kΩ ±5%, ¼W
R810	1	1	1	RT05223140	Fixed, 22kΩ ±5%, ¼W
R811	1	1	1	RT05243140	Fixed, 24kΩ ±5%, ¼W
R812	1	1	1	RT05243140	Fixed, 24kΩ ±5%, ¼W
R813	1	1	1	RT05473140	Fixed, 47kΩ ±5%, ¼W
R814	1	1	1	RT05473140	Fixed, 47kΩ ±5%, ¼W
R815	1	1	1	RT05153140	Fixed, 15kΩ ±5%, ¼W
R816	1	1	1	RT05153140	Fixed, 15kΩ ±5%, ¼W
R817	1	1	1	RT05223140	Fixed, 22kΩ ±5%, ¼W
R818	1	1	1	RT05223140	Fixed, 22kΩ ±5%, ¼W
R819	1	1	1	RT05153140	Fixed, 15kΩ ±5%, ¼W
R820	1	1	1	RT05153140	Fixed, 15kΩ ±5%, ¼W
R821	1	1	1	RT05242140	Fixed, 2.4kΩ ±5%, ¼W
R822	1	1	1	RT05242140	Fixed, 2.4kΩ ±5%, ¼W
R823	1	1	1	RT05473140	Fixed, 47kΩ ±5%, ¼W
R824	1	1	1	RT05473140	Fixed, 47kΩ ±5%, ¼W
R825	1	1	1	RT05103140	Fixed, 10kΩ ±5%, ¼W
R826	1	1	1	RT05103140	Fixed, 10kΩ ±5%, ¼W
R827	1	1	1	RT05393140	Fixed, 39kΩ ±5%, ¼W
R828	1	1	1	RT05393140	Fixed, 39kΩ ±5%, ¼W
R829	1	1	1	RT05303140	Fixed, 30kΩ ±5%, ¼W
R830	1	1	1	RT05303140	Fixed, 30kΩ ±5%, ¼W
R831	1	1	1	RT05103140	Fixed, 10kΩ ±5%, ¼W
R832	1	1	1	RT05103140	Fixed, 10kΩ ±5%, ¼W
R833	1	1	1	GF05100140	Fixed, 10Ω ±5%, ¼W
R834	1	1	1	GF05100140	Fixed, 10Ω ±5%, ¼W
R835	1	1	1	RT05104140	Fixed, 100kΩ ±5%, ¼W
R836	1	1	1	RT05104140	Fixed, 100kΩ ±5%, ¼W
R837	1	1	1	RT05104140	Fixed, 100kΩ ±5%, ¼W
R838	1	1	1	RT05104140	Fixed, 100kΩ ±5%, ¼W
R839	1	1	1	RT05104140	Fixed, 100kΩ ±5%, ¼W
R840	1	1	1	RT05104140	Fixed, 100kΩ ±5%, ¼W
C701	1	1	1	EE22503510	Electrolytic, 2.2μF ±20%, 35V
C702	1	1	1	EE22503510	Electrolytic, 2.2μF ±20%, 35V
C703	1	1	1	DD16101010	Ceramic, 100pF ±10%, 50V
C704	1	1	1	DD16101010	Ceramic, 100pF ±10%, 50V
C705	1	1	1	DD15100500	Ceramic, 10pF ±10%, 500V
C706	1	1	1	DD15100500	Ceramic, 10pF ±10%, 500V
C707	1	1	1	EA47505090	Electrolytic, 4.7μF +100%, -10%, 50V
C708	1	1	1	EA47505090	Electrolytic, 4.7μF +100%, -10%, 50V
C709	1	1	1	EA47405090	Electrolytic, 0.47μF +100%, -10%, 50V
C710	1	1	1	EA47405090	Electrolytic, 0.47μF +100%, -10%, 50V
C711	1	1	1	EA10701690	Electrolytic, 100μF +100%, -10%, 16V
C712	1	1	1	EA10701690	Electrolytic, 100μF +100%, -10%, 16V
C715	1	1	1	DD10030500	Ceramic, 3pF ±0.5pF, 16V

U: For U.S.A.
C: For Canada
E: For Europe

REF. DESIG.	Q'TY			PART NO.	DESCRIPTION
	U	C	E		
C716	1	1	1	DD10030500	Ceramic, 3pF ±0.5pF, 16V
C717	1	1	1	DF17104050	Film, 0.1µF ±20%, 16V
C718	1	1	1	DF17104050	Film, 0.1µF ±20%, 16V
C719	1	1	1	DF17104520	Film, 0.1µF ±20%, 200V
C720	1	1	1	DF17104520	Film, 0.1µF ±20%, 200V
C721	1	1	1	DF17104540	Film, 0.1µF ±20%, 100V
C722	1	1	1	DF17104540	Film, 0.1µF ±20%, 100V
C723	1	1	1	DF16104010	Film, 0.1µF ±10%, 50V
C724	1	1	1	DF16104010	Film, 0.1µF ±10%, 50V
C725	1	1	1	EE10505010	Electrolytic, 1µF ±20%, 50V
C726	1	1	1	EE10505010	Electrolytic, 1µF ±20%, 50V
C727	1	1	1	EE10505010	Electrolytic, 1µF ±20%, 50V
C728	1	1	1	EE10505010	Electrolytic, 1µF ±20%, 50V
C729	1	1	1	DF16104010	Film, 0.1µF ±10%, 50V
C730	1	1	1	DF16104010	Film, 0.1µF ±10%, 50V
C731	1	1	1	DK16221510	Ceramic, 220pF ±10%, 500V
C732	1	1	1	DK16221510	Ceramic, 220pF ±10%, 500V
C733	1	1	1	DF17104540	Film, 0.1µF ±20%, 100V
C734	1	1	1	DF17104540	Film, 0.1µF ±20%, 100V
C735	1	1	1	DF17104540	Film, 0.1µF ±20%, 100V
C736	1	1	1	DF17104540	Film, 0.1µF ±20%, 100V
C737	1	1	1	DK16221510	Ceramic, 220pF ±10%, 500V
C738	1	1	1	DK16221510	Ceramic, 220pF ±10%, 500V
C741	1	1	1	EA10505090	Electrolytic, 1µF +100%, -10%, 50V
C742	1	1	1	EA10505090	Electrolytic, 1µF +100%, -10%, 50V
C743	1	1	1	DF17104540	Film, 0.1µF ±20%, 100V
C744	1	1	1	DF17104540	Film, 0.1µF ±20%, 100V
C745	1	1	1	DK16221510	Ceramic, 220pF ±10%, 500V
C746	1	1	1	DK16221510	Ceramic, 220pF ±10%, 500V
C747	1	1	1	DD10030500	Ceramic, 3pF ±0.5pF, 500V
C748	1	1	1	DD10030500	Ceramic, 3pF ±0.5pF, 500V
C749	1	1	1	DF16222010	Film, 0.0022µF ±10%, 50V
C750	1	1	1	DF16222010	Film, 0.0022µF ±10%, 50V
C751	1	1	1	DF16222010	Film, 0.0022µF ±10%, 50V
C752	1	1	1	DF16222010	Film, 0.0022µF ±10%, 50V
C753	1	1	1	DD15500500	Ceramic, 50pF ±5%, 500V
C754	1	1	1	DD15500500	Ceramic, 50pF ±5%, 500V
C755	1	1	1	EA10610010	Electrolytic, 10µF +100%, -10%, 100V
C756	1	1	1	EA10610010	Electrolytic, 10µF +100%, -10%, 100V
C759	1	1	1	DF15152010	Film, 0.0015µF ±5%, 50V
C760	1	1	1	DF15152010	Film, 0.0015µF ±5%, 50V
P700 - SEMICONDUCTORS					
Q701	1	1	1	HT317752E0	Transistor, 2SC1775A E or F
Q702	1	1	1	HT317752E0	Transistor, 2SC1775A E or F
Q703	1	1	1	HT317752E0	Transistor, 2SC1775A E or F
Q704	1	1	1	HT317752E0	Transistor, 2SC1775A E or F
Q705	1	1	1	HT317752D0	Transistor, 2SC1775A D or E
Q706	1	1	1	HT317752D0	Transistor, 2SC1775A D or E
Q707	1	1	1	HT107332A0	Transistor, 2SA733 Q or R
Q708	1	1	1	HT107332A0	Transistor, 2SA733 Q or R
Q709	1	1	1	HT108792B0	Transistor, 2SA879 Q or R
Q710	1	1	1	HT108792B0	Transistor, 2SA879 Q or R
Q711	1	1	1	HT108792B0	Transistor, 2SA879 Q or R
Q712	1	1	1	HT108792B0	Transistor, 2SA879 Q or R
Q713	1	1	1	HT109392B0	Transistor, 2SA939 B or V
Q714	1	1	1	HT109392B0	Transistor, 2SA939 B or V
Q715	1	1	1	HT320712B0	Transistor, 2SC2071 B or V
Q716	1	1	1	HT320712B0	Transistor, 2SC2071 B or V
Q717	1	1	1	HT315682B0	Transistor, 2SC1568 R or S

REF. DESIG.	Q'TY			PART NO.	DESCRIPTION
	U	C	E		
Q718	1	1	1	HT315682B0	Transistor, 2SC1568 R or S
Q719	1	1	1	HT309452A0	Transistor, 2SC945 Q or R
Q720	1	1	1	HT309452A0	Transistor, 2SC945 Q or R
Q721	1	1	1	HT107332A0	Transistor, 2SA733 P or Q
Q722	1	1	1	HT107332A0	Transistor, 2SA733 P or Q
Q723	1	1	1	HT406102B0	Transistor, 2SD610 R or Q
Q724	1	1	1	HT406102B0	Transistor, 2SD610 R or Q
Q725	1	1	1	HT206302B0	Transistor, 2SB630 R or Q
Q726	1	1	1	HT206302B0	Transistor, 2SB630 R or Q
Q727	1	1	1	HT309452A0	Transistor, 2SC945 Q or R
Q728	1	1	1	HT309452A0	Transistor, 2SC945 Q or R
Q729	1	1	1	HT309452A0	Transistor, 2SC945 Q or R
Q730	1	1	1	HT309452A0	Transistor, 2SC945 Q or R
Q731	1	1	1	HT108792B0	Transistor, 2SA879 Q or R
Q732	1	1	1	HT108792B0	Transistor, 2SA879 Q or R
Q733	1	1	1	HT108792B0	Transistor, 2SA879 Q or R
Q734	1	1	1	HT108792B0	Transistor, 2SA879 Q or R
Q735	1	1	1	HT315732B0	Transistor, 2SC1573 Q or R
Q736	1	1	1	HT315732B0	Transistor, 2SC1573 Q or R
Q737	1	1	1	HD20003210	Diode, 1S2471
Q738	1	1	1	HD20003210	Diode, 1S2471
Q739	1	1	1	HD20003210	Diode, 1S2471
Q740	1	1	1	HD20003210	Diode, 1S2471
Q741	1	1	1	HD30023090	Diode, WZ071
Q742	1	1	1	HD30023090	Diode, WZ071
Q743	1	1	1	HD30002130	Diode, EQA01-35R
Q744	1	1	1	HD30002130	Diode, EQA01-35R
Q745	1	1	1	HD20003210	Diode, 1S2471
Q746	1	1	1	HD20003210	Diode, 1S2471
Q747	1	1	1	HD20003210	Diode, 1S2471
Q748	1	1	1	HD20003210	Diode, 1S2471
Q749	1	1	1	HD20003210	Diode, 1S2471
Q750	1	1	1	HD20003210	Diode, 1S2471
Q751	1	1	1	HD20003210	Diode, 1S2471
Q752	1	1	1	HD20003210	Diode, 1S2471
Q753	1	1	1	HD20003210	Diode, 1S2471
Q754	1	1	1	HD20003210	Diode, 1S2471
Q755	1	1	1	HD20003210	Diode, 1S2471
Q756	1	1	1	HD20003210	Diode, 1S2471
Q757	1	1	1	HD20003210	Diode, 1S2471
Q758	1	1	1	HD20003210	Diode, 1S2471
Q759	1	1	1	HD20003210	Diode, 1S2471
Q760	1	1	1	HD20003210	Diode, 1S2471
Q761	1	1	1	HD20003210	Diode, 1S2471
Q762	1	1	1	HD20003210	Diode, 1S2471
Q763	1	1	1	HD20003210	Diode, 1S2471
Q764	1	1	1	HD20003210	Diode, 1S2471
Q765	1	1	1	HD20011010	Diode, W06C
Q766	1	1	1	HD20011010	Diode, W06C
Q767	1	1	1	HD20011010	Diode, W06C
Q768	1	1	1	HD20011010	Diode, W06C
Q769	1	1	1	HD30023090	Diode, WZ071
Q770	1	1	1	HD30023090	Diode, WZ071
Q771	1	1	1	HD20002210	Diode, 1S2472
Q772	1	1	1	HD20002210	Diode, 1S2472
Q773	1	1	1	HD20002210	Diode, 1S2472
Q774	1	1	1	HD20002210	Diode, 1S2472
Q775	1	1	1	HD20010010	Diode, W06C
Q776	1	1	1	HD20010010	Diode, W06C
Q777	1	1	1	HD20010010	Diode, W06C
Q778	1	1	1	HD20010010	Diode, W06C
Q779	1	1	1	HD20010010	Diode, W06C
Q780	1	1	1	HD20010010	Diode, W06C

U : For U.S.A.
C : For Canada
E : For Europe

REF. DESIG.	Q'TY			PART NO.	DESCRIPTION
	U	C	E		
Q781	1	1	1	HV00003120	Varistor, MV-13
Q782	1	1	1	HV00003120	Varistor, MV-13
P700 - MISCELLANEOUS					
L701	1	1	1	LC22220010	Choke Coil, 2.2μH
L702	1	1	1	LC22220010	Choke Coil, 2.2μH
P708	116	116	116	2933118020	Spacer
P711	28	28	28	75061251P0	Jumper Wire
J709	?	6	6	YP06001040	Plug, 3P
J714	?	16	16	YP10001130	Plug
J719	?	16	16	YP10001130	Plug
J734	?	16	16	YP10001130	Plug
J737	1	1	1	YP06001040	Plug, 3P
J738	1	1	1	YP06001040	Plug, 3P
J739	?	4	4	YP10001130	Plug
J742	?	4	4	YP10001130	Plug
POWER SUPPLY CIRCUIT BOARD - P850					
P850	1	1	1	YD22182040	P.W. Board (Print Only)
	1	1	1	ZZ22182040	P.W. Board Assembly
			1	ZZ22188040	P.W. Board Assembly
P850 - RESISTORS					
R851	1	1	1	GF05102140	Fixed, 1kΩ ±5%, ¼W
R852	1	1	1	GF05301140	Fixed, 300Ω ±5%, ¼W
R853	1	1	1	RT05102140	Fixed, 1kΩ ±5%, ¼W
R854	1	1	1	RT05301140	Fixed, 300Ω ±5%, ¼W
R855	1	1	1	RT05332140	Fixed, 3.3kΩ ±5%, ¼W
R856	1	1	1	RT05822140	Fixed, 8.2kΩ ±5%, ¼W
R857	1	1	1	RT05752140	Fixed, 7.5kΩ ±5%, ¼W
R858	1	1	1	RT05303140	Fixed, 30kΩ ±5%, ¼W
R859	1	1	1	RT05392140	Fixed, 3.9kΩ ±5%, ¼W
R860	1	1	1	RT05333140	Fixed, 33kΩ ±5%, ¼W
R861	1	1	1	GJ05241020	Fixed, 240Ω ±5%, 2W
R862	1	1	1	GJ05561010	Fixed, 560Ω ±5%, 1W
R863	1	1	1	GS10820050	Fixed, 82Ω ±10%, 5W
R864	1	1	1	GJ05301010	Fixed, 300Ω ±5%, 1W
R865	1	1	1	RT05682140	Fixed, 6.8kΩ ±5%, ¼W
R866	1	1	1	RT05752140	Fixed, 7.5kΩ ±5%, ¼W
R868	1	1	1	GJ05470020	Fixed, 47Ω ±5%, 2W
R869	1	1	1	GJ05470020	Fixed, 47Ω ±5%, 2W
R870	1	1	1	GF05390140	Fixed, 39Ω ±5%, ¼W
P850 - CAPACITORS					
C851	1	1	1	DK18103510	Ceramic, 0.01μF ±20%, 200V
C852	1	1	1	DK18103510	Ceramic, 0.01μF ±20%, 200V
C853	1	1	1	EA47701090	Electrolytic, 470μF +100%, -20%, 10V
C854	1	1	1	ED10805010	Electrolytic, 1000μF +100%, -20%, 50V
C855	1	1	1	ED47705020	Electrolytic, 470μF +100%, -20%, 50V
C856	1	1	1	EA10701690	Electrolytic, 100μF +100%, -10%, 16V
C857	1	1	1	EA10701690	Electrolytic, 100μF +100%, -10%, 16V
C858	1	1	1	DK18103510	Ceramic, 0.01μF ±20%, 200V
C859	1	1	1	DK18103510	Ceramic, 0.01μF ±20%, 200V
C860	1	1	1	EA33502590	Electrolytic, 3.3μF +100%, -10%, 25V

REF. DESIG.	Q'TY			PART NO.	DESCRIPTION
	U	C	E		
C861	1	1	1	EA33502590	Electrolytic, 3.3μF +100%, -10%, 25V
C862	1	1	1	EA22701690	Electrolytic, 220μF +100%, -10%, 16V
C863	1	1	1	DK18103510	Ceramic, 0.01μF ±20%, 200V
C864	1	1	1	DK18103510	Ceramic, 0.01μF ±20%, 200V
C865	1	1	1	EA33601690	Electrolytic, 33μF +100%, -20%, 16V
C867	1	1	1	DK18103510	Ceramic, 0.01μF ±20%, 200V
C868	1	1	1	DK18103510	Ceramic, 0.01μF ±20%, 200V
C869	1	1	1	EA22703590	Electrolytic, 220μF +100%, -20%, 35V
P850 - SEMICONDUCTORS					
Q851	1	1	1	HD20004130	Diode, S1B01-02
Q852	1	1	1	HD20012030	Diode, DS-132B
Q853	1	1	1	HD20011030	Diode, DS-131B
Q854	1	1	1	HT309452A0	Transistor, 2SC945 Q or R
Q855	1	1	1	HT309452A0	Transistor, 2SC945 Q or R
Q856	1	1	1	HT309452A0	Transistor, 2SC945 Q or R
Q857	1	1	1	HT403302A0	Transistor, 2SD330 D or E
Q858	1	1	1	HT309452A0	Transistor, 2SC945 Q or R
Q859	1	1	1	HT106842B0	Transistor, 2SA684 Q or R
Q860	1	1	1	HT107332A0	Transistor, 2SA733 Q or R
Q861	1	1	1	HT107332A0	Transistor, 2SA733 Q or R
Q862	1	1	1	HD30027090	Diode, WZ140
Q863	1	1	1	HD20002210	Diode, 1S2472
P850 - MISCELLANEOUS					
P857	22	22	22	3444118050	Spacer
F851	1	1	1	FS10050090	Fuse, 500mA (UL)
F851	1	1	1	FS10050800	Fuse, 500mA
F852	1	1	1	FS10050090	Fuse, 500mA (UL)
F852	1	1	1	FS10050800	Fuse, 500mA
F853	1	1	1	FS10200060	Fuse, 2A (UL)
F853	1	1	1	FS10200800	Fuse, 2A
J851	?	17	17	YP10001130	Plug
J867	?	6	6	YJ08000210	Socket, Fuse
J868	?	6	6	YJ08000210	Socket, Fuse
J873	?	6	6	YJ08000210	Socket, Fuse
PRE & TONE AMP CIRCUIT BOARD - PE00					
PE00	1	1	1	YA22180210	P.W. Board (Print Only)
	1	1	1	ZZ22180210	P.W. Board Assembly
PE00 - RESISTORS					
RE01	1	1	1	RT05224140	Fixed, 220kΩ ±5%, ¼W
RE02	1	1	1	RT05224140	Fixed, 220kΩ ±5%, ¼W
RE03	1	1	1	RT05105140	Fixed, 1MΩ ±5%, ¼W
RE04	1	1	1	RT05105140	Fixed, 1MΩ ±5%, ¼W
RE05	1	1	1	RT05104140	Fixed, 100kΩ ±5%, ¼W
RE06	1	1	1	RT05104140	Fixed, 100kΩ ±5%, ¼W
RE07	1	1	1	RT05154140	Fixed, 150kΩ ±5%, ¼W
RE08	1	1	1	RT05154140	Fixed, 150kΩ ±5%, ¼W
RE09	1	1	1	RT05203140	Fixed, 20kΩ ±5%, ¼W
RE10	1	1	1	RT05203140	Fixed, 20kΩ ±5%, ¼W
RE11	1	1	1	RT05224140	Fixed, 220kΩ ±5%, ¼W
RE12	1	1	1	RT05224140	Fixed, 220kΩ ±5%, ¼W
RE13	1	1	1	RT05103140	Fixed, 10kΩ ±5%, ¼W
RE14	1	1	1	RT05103140	Fixed, 10kΩ ±5%, ¼W

U : For U.S.A.
 C : For Canada
 E : For Europe

REF. DESIG.	Q'TY			PART NO.	DESCRIPTION
	U	C	E		
RE15	1	1	1	RT05105140	Fixed, 1M Ω \pm 5%, 1/4W
RE16	1	1	1	RT05105140	Fixed, 1M Ω \pm 5%, 1/4W
RE17	1	1	1	RT05104140	Fixed, 100k Ω \pm 5%, 1/4W
RE18	1	1	1	RT05104140	Fixed, 100k Ω \pm 5%, 1/4W
RE19	1	1	1	RT05224140	Fixed, 220k Ω \pm 5%, 1/4W
RE20	1	1	1	RT05224140	Fixed, 220k Ω \pm 5%, 1/4W
RE21	1	1	1	RT05113140	Fixed, 11k Ω \pm 5%, 1/4W
RE22	1	1	1	RT05113140	Fixed, 11k Ω \pm 5%, 1/4W
RE23	1	1	1	RT05113140	Fixed, 11k Ω \pm 5%, 1/4W
RE24	1	1	1	RT05113140	Fixed, 11k Ω \pm 5%, 1/4W
RE25	1	1	1	RT05183140	Fixed, 18k Ω \pm 5%, 1/4W
RE26	1	1	1	RT05183140	Fixed, 18k Ω \pm 5%, 1/4W
RE27	1	1	1	RT05183140	Fixed, 18k Ω \pm 5%, 1/4W
RE28	1	1	1	RT05183140	Fixed, 18k Ω \pm 5%, 1/4W
RE29	1	1	1	RT05273140	Fixed, 27k Ω \pm 5%, 1/4W
RE30	1	1	1	RT05273140	Fixed, 27k Ω \pm 5%, 1/4W
RE31	1	1	1	RT05562140	Fixed, 5.6k Ω \pm 5%, 1/4W
RE32	1	1	1	RT05562140	Fixed, 5.6k Ω \pm 5%, 1/4W
RE33	1	1	1	RT05183140	Fixed, 18k Ω \pm 5%, 1/4W
RE34	1	1	1	RT05183140	Fixed, 18k Ω \pm 5%, 1/4W
RE35	1	1	1	RT05183140	Fixed, 18k Ω \pm 5%, 1/4W
RE36	1	1	1	RT05183140	Fixed, 18k Ω \pm 5%, 1/4W
RE39	1	1	1	RD01040070	Variable, 100k Ω (B), Bass
RE40	1	1	1	RD01040070	Variable, 100k Ω (B), Mid
RE41	1	1	1	RD01040070	Variable, 100k Ω (B), Treble
RE42	1	1	1	RG02030010	Variable, 20k Ω (B)/250k Ω (V), Volume
RE43	1	1	1	RT05562140	Fixed, 5.6k Ω \pm 5%, 1/4W
RE44	1	1	1	RT05562140	Fixed, 5.6k Ω \pm 5%, 1/4W
RE45	1	1	1	RT05562140	Fixed, 5.6k Ω \pm 5%, 1/4W
RE46	1	1	1	RT05562140	Fixed, 5.6k Ω \pm 5%, 1/4W
RE49	1	1	1	RT05564140	Fixed, 560k Ω \pm 5%, 1/4W
RE50	1	1	1	RT05564140	Fixed, 560k Ω \pm 5%, 1/4W
CE01	1	1	1	EE22503510	Electrolytic, 2.2 μ F \pm 20%, 35V
CE02	1	1	1	EE22503510	Electrolytic, 2.2 μ F \pm 20%, 35V
CE03	1	1	1	EE22601640	Electrolytic, 22 μ F \pm 20%, 16V
CE04	1	1	1	EE22601640	Electrolytic, 22 μ F \pm 20%, 16V
CE05	1	1	1	EA10601690	Electrolytic, 10 μ F +100%, -10%, 16V
CE06	1	1	1	EA10601690	Electrolytic, 10 μ F +100%, -10%, 16V
CE07	1	1	1	DD15500050	Ceramic, 50pF \pm 5%, 50V
CE08	1	1	1	DD15500050	Ceramic, 50pF \pm 5%, 50V
CE09	1	1	1	DD12100010	Ceramic, 10pF \pm 1pF, 50V
CE10	1	1	1	DD12100010	Ceramic, 10pF \pm 1pF, 50V
CE11	1	1	1	EE10505010	Electrolytic, 1 μ F \pm 20%, 50V
CE12	1	1	1	EE10505010	Electrolytic, 1 μ F \pm 20%, 50V
CE13	1	1	1	EE47502540	Electrolytic, 4.7 μ F \pm 20%, 25V
CE14	1	1	1	EE47502540	Electrolytic, 4.7 μ F \pm 20%, 25V
CE15	1	1	1	DD15500050	Ceramic, 50pF \pm 5%, 50V
CE16	1	1	1	DD15500050	Ceramic, 50pF \pm 5%, 50V
CE17	1	1	1	DD16200010	Ceramic, 20pF \pm 10%, 50V
CE18	1	1	1	DD16200010	Ceramic, 20pF \pm 10%, 50V
CE19	1	1	1	DF16123010	Film, 0.012 μ F \pm 10%, 50V
CE20	1	1	1	DF16123010	Film, 0.012 μ F \pm 10%, 50V
CE21	1	1	1	DF16123010	Film, 0.012 μ F \pm 10%, 50V
CE22	1	1	1	DF16123010	Film, 0.012 μ F \pm 10%, 50V
CE23	1	1	1	DF17224020	Film, 0.22 μ F \pm 20%, 50V
CE24	1	1	1	DF17224020	Film, 0.22 μ F \pm 20%, 50V
CE25	1	1	1	DF16682010	Film, 0.0068 μ F \pm 10%, 50V
CE26	1	1	1	DF16682010	Film, 0.0068 μ F \pm 10%, 50V
CE27	1	1	1	DD16501010	Ceramic, 500pF \pm 10%, 50V

REF. DESIG.	Q'TY			PART NO.	DESCRIPTION
	U	C	E		
CE28	1	1	1	DD16501010	Ceramic, 500pF \pm 10%, 50V
CE29	1	1	1	DF16222010	Film, 0.0022 μ F \pm 10%, 50V
CE30	1	1	1	DF16222010	Film, 0.0022 μ F \pm 10%, 50V
CE31	1	1	1	DF16332010	Film, 0.0033 μ F \pm 10%, 50V
CE32	1	1	1	DF16332010	Film, 0.0033 μ F \pm 10%, 50V
CE33	1	1	1	DD15201010	Ceramic, 200pF \pm 10%, 50V
CE34	1	1	1	DD15201010	Ceramic, 200pF \pm 10%, 50V
CE35	1	1	1	EA10701690	Electrolytic, 100 μ F +100%, -10%, 16V
CE36	1	1	1	EA10701690	Electrolytic, 100 μ F +100%, -10%, 16V
CE37	1	1	1	DD12100010	Ceramic, 10pF \pm 1pF, 50V
CE38	1	1	1	DD12100010	Ceramic, 10pF \pm 1pF, 50V
CE41	1	1	1	DK18103010	Ceramic, 0.01 μ F \pm 1pF, 50V
CE42	1	1	1	DK18103010	Ceramic, 0.01 μ F \pm 1pF, 50V
CE43	1	1	1	DF16392010	Film, 3900pF \pm 10%, 50V
CE44	1	1	1	DF16392010	Film, 3900pF \pm 10%, 50V
CE45	1	1	1	DF16392010	Film, 3900pF \pm 10%, 50V
CE46	1	1	1	DF16392010	Film, 3900pF \pm 10%, 50V
CE47	1	1	1	DD12030010	Ceramic, 3pF \pm 1pF, 50V
CE48	1	1	1	DD12030010	Ceramic, 3pF \pm 1pF, 50V
SE01	1	1	1	SR04050130	PE00 - MISCELLANEOUS Rotary Switch, Tone Mode
QE01	1	1	1	HC10022050	IC, TA7136P
QE02	1	1	1	HC10022050	IC, TA7136P
QE03	1	1	1	HC10022050	IC, TA7136P
QE04	1	1	1	HC10022050	IC, TA7136P
PE11	18	18	18	75061251P0	Jumper Wire
JE01	1	1	1	YP06001040	Plug, 3P
JE02	1	1	1	YP06001040	Plug, 3P
JE04	1	1	1	YP06001040	Plug, 3P
JE05	1	1	1	YJ06000490	Jack, 9P
JE06	1	1	1	YJ06000740	Jack, 3P
JE07	1	1	1	YJ06000740	Jack, 3P
PK00	1	1	1	YA22180310 ZZ22180310	DOLBY NR SOCKET CIRCUIT BOARD - PK00 P.W. Board (Print Only) P.W. Board Assembly
SK01	1	1	1	SC01020240	PK00 - MISCELLANEOUS Switch, AH2524
SK02	1	1	1	SC01020240	Switch, AH2524
JK01	1	1	1	YP10001130	Plug
JK02	1	1	1	YP10001130	Plug
JK03	1	1	1	YP10001130	Plug
JK04	1	1	1	YP10001130	Plug
JK05	1	1	1	YP10001130	Plug
JK06	1	1	1	YP10001130	Plug
JK07	1	1	1	YP10001130	Plug
JK08	1	1	1	YP10001130	Plug
JK09	1	1	1	YJ07000120	Socket, 10P
PN00	1	1	1	YA22180510 ZZ22180510	AUDIO MUTING CIRCUIT BOARD - PN00 P.W. Board (Print Only) P.W. Board Assembly

U: For U.S.A.
C: For Canada
E: For Europe

REF. DESIG.	Q'TY			PART NO.	DESCRIPTION
	U	C	E		
RT15	1	1	1	GD05153140	Fixed, 15kΩ ±5%, ¼W
RT16	1	1	1	GD05153140	Fixed, 15kΩ ±5%, ¼W
RT17	1	1	1	GD05393140	Fixed, 39kΩ ±5%, ¼W
RT18	1	1	1	GD05393140	Fixed, 39kΩ ±5%, ¼W
RT19	1	1	1	GD05913140	Fixed, 91kΩ ±5%, ¼W
RT20	1	1	1	GD05913140	Fixed, 91kΩ ±5%, ¼W
RT21	1	1	1	GD05821140	Fixed, 820Ω ±5%, ¼W
RT22	1	1	1	GD05821140	Fixed, 820Ω ±5%, ¼W
RT23	1	1	1	GD05562140	Fixed, 5.6kΩ ±5%, ¼W
RT24	1	1	1	GD05562140	Fixed, 5.6kΩ ±5%, ¼W
RT25	1	1	1	GD05113140	Fixed, 11kΩ ±5%, ¼W
RT26	1	1	1	GD05113140	Fixed, 11kΩ ±5%, ¼W
RT27	1	1	1	GD05222140	Fixed, 2.2kΩ ±5%, ¼W
RT28	1	1	1	GD05222140	Fixed, 2.2kΩ ±5%, ¼W
RT29	1	1	1	GD05225140	Fixed, 2.2MΩ ±5%, ¼W
RT30	1	1	1	GD05225140	Fixed, 2.2MΩ ±5%, ¼W
PT00 - CAPACITORS					
CT01	1	1	1	DF16104010	Film, 0.1μF ±10%, 50V
CT02	1	1	1	DF16104010	Film, 0.1μF ±10%, 50V
CT03	1	1	1	DF15223010	Film, 0.022μF ±5%, 50V
CT04	1	1	1	DF15223010	Film, 0.022μF ±5%, 50V
CT05	1	1	1	DF15223010	Film, 0.022μF ±5%, 50V
CT06	1	1	1	DF15223010	Film, 0.022μF ±5%, 50V
CT07	1	1	1	EV33502560	Electrolytic, 3.3μF ±20%, 25V
CT08	1	1	1	EV33502560	Electrolytic, 3.3μF ±20%, 25V
CT09	1	1	1	DK16681010	Ceramic, 680pF ±10%, 50V
CT10	1	1	1	DK16681010	Ceramic, 680pF ±10%, 50V
CT11	1	1	1	DK16471010	Ceramic, 470pF ±10%, 50V
CT12	1	1	1	DK16471010	Ceramic, 470pF ±10%, 50V
CT13	1	1	1	DF17273050	Film, 0.027μF ±10%, 50V
CT14	1	1	1	DF17273050	Film, 0.027μF ±10%, 50V
CT15	1	1	1	DD15391010	Ceramic, 390pF ±10%, 50V
CT16	1	1	1	DD15391010	Ceramic, 390pF ±10%, 50V
CT17	1	1	1	DD11040010	Ceramic, 4pF ±0.5pF, 50V
CT18	1	1	1	DD11040010	Ceramic, 4pF ±0.5pF, 50V
CT19	1	1	1	EV22403560	Electrolytic, 0.22μF ±10%, 35V
CT20	1	1	1	EV22403560	Electrolytic, 0.22μF ±10%, 35V
CT21	1	1	1	DD15121010	Ceramic, 120pF ±5%, 35V
CT22	1	1	1	DD15121010	Ceramic, 120pF ±5%, 35V
CT23	1	1	1	EA47601690	Electrolytic, 47μF +100%, -10%, 16V
CT24	1	1	1	EA47601690	Electrolytic, 47μF +100%, -10%, 16V
PT00 - MISCELLANEOUS					
QT01	1	1	1	HT107332A0	Transistor, 2SA733 Q or R
QT02	1	1	1	HT107332A0	Transistor, 2SA733 Q or R
QT03	1	1	1	HT313272B0	Transistor, 2SC1327 T or U
QT04	1	1	1	HT313272B0	Transistor, 2SC1327 T or U
JT01	1	1	1	YP06000340	Plug, 3P
JT02	1	1	1	YP06000340	Plug, 3P
JT03	1	1	1	YP06000700	Plug, 9P
JT04	1	1	1	YP10001130	Plug
PT11	14	14	14	75061001P0	Jumper Wire
ST01	1	1	1	SP02040040	Pushswitch
DUBBING IN & OUT JACKS CIRCUIT BOARD - PV00					
PV00	1	1	1	YD22180010	P.W. Board (Print Only)
	1	1	1	ZZ22180010	P.W. Board Assembly

REF. DESIG.	Q'TY			PART NO.	DESCRIPTION
	U	C	E		
JV01	1	1	1	YP06000570	PV00 - MISCELLANEOUS Plug, 3P
JV02	1	1	1	YJ06000760	Socket, 5P
JV03	1	1	1	YJ01001040	Jack
JV04	1	1	1	YJ01001050	Jack
SPEAKER SYSTEM SWITCH & ATTENUATOR CIRCUIT BOARD - PW00					
PW00	1	1	1	YD22180050	P.W. Board (Print Only)
	1	1	1	ZZ22180050	P.W. Board Assembly
PW00 - RESISTORS					
RW01	1	1	1	GS10331070	Fixed, 330Ω ±10%, 7W
RW02	1	1	1	GS10331070	Fixed, 330Ω ±10%, 7W
RW03	1	1	1	RJ05151020	Fixed, 150Ω ±5%, 2W
RW04	1	1	1	RJ05151020	Fixed, 150Ω ±5%, 2W
PW00 - MISCELLANEOUS					
SW01	1	1	1	SP04020180	Pushswitch, Speaker
JW01	1	1	1	YP10001130	Plug
JW02	1	1	1	YP10001130	Plug
JW03	1	1	1	YP10001130	Plug
JW04	1	1	1	YP10001130	Plug
JW05	1	1	1	YP10001130	Plug
PEAK & FUNCTION INDICATOR LED CIRCUIT BOARD - PY00					
PY00	1	1	1	YD22180030	P.W. Board (Print Only)
	1	1	1	ZZ22180030	P.W. Board Assembly
	1	1	1	ZZ22188030	P.W. Board Assembly
PY00 - MISCELLANEOUS					
QY01	1	1	1	H110004030	Led, SLP-132B
QY02	1	1	1	H110004030	Led, SLP-132B
QY03	1	1	1	H110004030	Led, SLP-132B
QY04	1	1	1	H110004030	Led, SLP-132B
QY05	1	1	1	H110004030	Led, SLP-132B
QY06	1	1	1	H110004030	Led, SLP-132B
QY07	1	1	1	H110004030	Led, SLP-132B
QY08	1	1	1	H110004030	Led, SLP-132B
QY09	1	1	1	H110004030	Led, SLP-132B
RY01	1	1	1	RT05152140	Resistor, Fixed, 1.5kΩ ±5%, ¼W
RY02	1	1	1	RT05152140	Resistor, Fixed, 1.5kΩ ±5%, ¼W
PY11	1	1	1	75061251P0	Jumper Wire
JY01	1	1	1	YP10001130	Plug
JY03	1	1	1	YP10001130	Plug
JY04	1	1	1	YP10001130	Plug
JY05	1	1	1	YP10001130	Plug
JY08	1	1	1	YP10001130	Plug
JY10	1	1	1	YP10001130	Plug
JY15	1	1	1	YP10001130	Plug
JY16	1	1	1	YP10001130	Plug
JY17	1	1	1	YP10001130	Plug
JY18	1	1	1	YP10001130	Plug
JY19	1	1	1	YP10001130	Plug
JY20	1	1	1	YP10001130	Plug
JY23	1	1	1	YP10001130	Plug

U : For U.S.A.
C : For Canada
E : For Europe

REF. DESIG.	Q'TY			PART NO.	DESCRIPTION
	U	C	E		
PZ00	1	1	1	YD22180040	DIAL LAMP CIRCUIT BOARD - PZ00 P.W. Board (Print Only)
	1	1		ZZ22180040	P.W. Board Assembly
			1	ZZ22188140	P.W. Board Assembly
PZ01 - MISCELLANEOUS					
VZ01	1	1	1	IN10080070	Lamp, Dial
VZ02	1	1	1	IN10080070	Lamp, Dial
VZ03	1	1	1	IN10080070	Lamp, Dial
VZ04	1	1	1	IN10080070	Lamp, Dial
VZ05	1	1	1	IN10080070	Lamp, Dial
VZ06	1	1	1	IN10080070	Lamp, Dial
JZ21	1	1	1	YP10001130	Plug
JZ01	1	1	1	YP10001130	Plug
JZ02	1	1	1	YP10001130	Plug
JZ03	1	1	1	YP10001130	Plug
JZ04	1	1	1	YP10001130	Plug
JZ05	1	1	1	YJ08000170	Socket
JZ06	1	1	1	YJ08000170	Socket
JZ07	1	1	1	YJ08000170	Socket
JZ08	1	1	1	YJ08000170	Socket
JZ09	1	1	1	YJ08000170	Socket
JZ10	1	1	1	YJ08000170	Socket
JZ11	1	1	1	YJ08000170	Socket
JZ12	1	1	1	YJ08000170	Socket
JZ13	1	1	1	YJ08000170	Socket
JZ14	1	1	1	YJ08000170	Socket
JZ15	1	1	1	YJ08000170	Socket
JZ16	1	1	1	YJ08000170	Socket
JZ17	1	1	1	YP10001130	Plug
JZ18	1	1	1	YP10001130	Plug
JZ19	1	1	1	YP10001130	Plug
JZ20	1	1	1	YP10001130	Plug
GENERAL MISCELLANEOUS					
J001	1	1	1	BY04050010	Terminal, Antenna
J002	1	1	1	YT02010130	Terminal, FM Quadradi- al Output
J003	1	1	1	YT02040190	Terminal, Phono
J004	1	1	1	YT02020140	Terminal, Aux
J004	1	1	1	YT02040140	Terminal, Aux
J005	1	1	1	YT02040140	Terminal, Tape 1
J006	1	1	1	YT02040140	Terminal, Tape 2
J007	1	1	1	YT02040170	Terminal, Pre Out/Main In
J008	1	1	1	YT03040160	Terminal, Speaker System 1
J009	1	1	1	YT03040160	Terminal, Speaker System 2
J010	1	1	1	YJ01001060	Jack, Phones
J011	1	1	1	YJ04000560	Jack, AC Outlet
J012	1	1	1	YJ04000560	Jack, AC Outlet
J013	1	1	1	YJ08000120	Jack, Fuse Holder
J013	1	1	1	YJ08000220	Jack, Fuse Holder
J014	1	1	1	YT01010050	Terminal, Chassis Ground
J015	1	1	1	YJ08000190	Jack, Lamp Socket
J016	1	1	1	YJ08000190	Jack, Lamp Socket
J017	1	1	1	YJ06001040	Jack, 3P Socket
J018	1	1	1	YJ06001040	Jack, 3P Socket
J019	1	1	1	YJ06001040	Jack, 3P Socket
J020	1	1	1	YJ06001040	Jack, 3P Socket
J021	1	1	1	YJ06001040	Jack, 3P Socket
J022	1	1	1	YJ06001040	Jack, 3P Socket
J023	1	1	1	YJ06001040	Jack, 3P Socket

REF. DESIG.	Q'TY			PART NO.	DESCRIPTION
	U	C	E		
J024	1	1	1	YJ06001040	Jack, 3P Socket
J025	1	1	1	YJ06001040	Jack, 3P Socket
J026	1	1	1	YJ06001040	Jack, 3P Socket
J027	1	1	1	YJ06001040	Jack, 3P Socket
J028	1	1	1	YJ06001040	Jack, 3P Socket
J029	1	1	1	YJ06001040	Jack, 3P Socket
J030	1	1	1	YJ06001040	Jack, 3P Socket
J031	1	1	1	YJ06001260	Jack, 7P Socket
J032	1	1	1	YJ06001040	Jack, 3P Socket
J033	1	1	1	YJ06001060	Jack, 7P Socket
J036	1	1	1	YJ06001040	Jack, 3P Socket
J037	1	1	1	YJ06001040	Jack, 3P Socket
J038	1	1	1	YJ06001040	Jack, 3P Socket
J039			1	BY03110010	Terminal, Voltage Conversion
J040	1	1	1	YJ06001270	Jack, 6P Socket
J041	1	1	1	YJ06001270	Jack, 6P Socket
J042	1	1	1	YJ06001040	Jack, 3P Socket
J043	1	1	1	YJ06001040	Jack, 3P Socket
J044	1	1	1	YJ06001040	Jack, 3P Socket
J045	1	1	1	YJ06001040	Jack, 3P Socket
J046	1	1	1	YJ05000220	Jack, Transistor Socket
J047	1	1	1	YJ05000220	Jack, Transistor Socket
J048	1	1	1	YJ05000220	Jack, Transistor Socket
J049	1	1	1	YJ05000220	Jack, Transistor Socket
J050	1	1	1	YJ05000220	Jack, Transistor Socket
J051	1	1	1	YJ05000220	Jack, Transistor Socket
J052	1	1	1	YJ05000220	Jack, Transistor Socket
J053	1	1	1	YJ05000220	Jack, Transistor Socket
J054	1	1	1	YJ05000220	Jack, Transistor Socket
J055	1	1	1	YJ05000220	Jack, Transistor Socket
J056	1	1	1	YJ05000220	Jack, Transistor Socket
J057	1	1	1	YJ05000220	Jack, Transistor Socket
J058	1	1	1	YJ10000850	Jack, Relay Connector
J059	1	1	1	YJ06001040	Jack, 3P Socket
J060	1	1	1	YJ06001040	Jack, 3P Socket
J061	1	1	1	YL01020080	Terminal, 2P
J062	1	1	1	YJ06001040	Jack, 3P Socket
J063	1	1	1	YJ06001040	Jack, 3P Socket
J064	1	1	1	YJ06001060	Jack, 7P Socket
J065	1	1	1	YJ06001040	Jack, 3P Socket
L001	1	1	1	TS44501010	Power Transformer
L001	1	1	1	TS44501020	Power Transformer
L002	1	1	1	LF11200520	Antenna Coil, AM
L003	1	1	1	LB30075260	Balun Coil
L004	1	1	1	LC11540020	Choke Coil
L005	1	1	1	LY20480030	Relay, Soft Start
L005	1	1	1	LY20480040	Relay, Soft Start
R001	1	1	1	RK02030322	Resistor, Variable, 20k Ω (B), FM Muting
R002	1	1	1	RC10225120	Resistor, Fixed, 2.2M Ω \pm 10%, $\frac{1}{2}W$
R003	1	1	1	GS10220100	Resistor, Fixed, 22 Ω \pm 10%, $\frac{1}{2}W$
R004	1	1	1	RT05432140	Resistor, Fixed, 4.3k Ω \pm 5%, $\frac{1}{2}W$
R005	1	1	1	RS02540110	Resistor, Variable, 25k Ω , Balance
R006	1	1	1	GS05472020	Resistor, Fixed, 4.7k Ω \pm 5%, 2W
R007	1	1	1	GS05472020	Resistor, Fixed, 4.7k Ω \pm 5%, 2W
C001	1	1	1	DK18103010	Capacitor, Ceramic, 0.01 μ F \pm 20%, 50V

U: For U.S.A.
 C: For Canada
 E: For Europe

REF. DESIG.	Q'TY			PART NO.	DESCRIPTION
	U	C	E		
C002	1	1	1	DK18103010	Capacitor, Ceramic, 0.01μF ±20%, 50V
C003	1	1	1	EA33601090	Capacitor, Electrolytic, 33μF +100%, -10%, 10V
C004	1	1	1	EA33601090	Capacitor, Electrolytic, 33μF +100%, -10%, 10V
C005	1	1	1	DF17223520	Capacitor, Film, 0.022μF, 400V
C006	1	1	1	DF17223520	Capacitor, Film, 0.022μF, 400V
C007	1	1	1	DF17223520	Capacitor, Film, 0.022μF, 400V
C008	1	1	1	DF17223520	Capacitor, Film, 0.022μF, 400V
C009	1	1	1	DF17223520	Capacitor, Film, 0.022μF, 400V
C010	1	1	1	DF17223520	Capacitor, Film, 0.022μF, 400V
C011	1	1	1	ES68808510	Capacitor, Electrolytic, 6800μF, 85Vx2
C012	1	1	1	ES68808510	Capacitor, Electrolytic, 6800μF, 85Vx2
C013	1	1	1	DF17333510	Capacitor, Film, 0.033μF ±20%, 250V
M001	1	1	1	IM11055050	DC Meter, FM Tuning
M002	1	1	1	IM11055040	DC Meter, Signal Strength
V001	1	1	1	IN10080070	Lamp, Meter, 8V
V002	1	1	1	IN10080070	Lamp, Meter, 8V
V003	1	1	1	IN10080090	Lamp, Dolby
V004	1	1	1	IN10080340	Lamp, Stereo
F001	1	1	1	FS11000050	Fuse, 10A (UL)
F001	1	1	1	FS11000040	Fuse, 10A
F001	1	1	1	FS10500800	Fuse, 5A
F002	1	1	1	FS21000010	Fuse, 10A
G001	1	1	1	BF10400030	Printed Comp. (UL)
G001	1	1	1	BF33300020	Printed Comp. (CSA)
S001	1	1	1	SP04010230	Pushswitch, Power
Q001	1	1	1	HD20004290	Diode, S5VB20
Q002	1	1	1	HD20004290	Diode, S5VB20
Q003	1	1	1	HT315852B0	Transistor, 2SC1585 O or Y
Q004	1	1	1	HT315852B0	Transistor, 2SC1585 O or Y
Q005	1	1	1	HT315852B0	Transistor, 2SC1585 O or Y
Q006	1	1	1	HT315852B0	Transistor, 2SC1585 O or Y
Q007	1	1	1	HT315852B0	Transistor, 2SC1585 O or Y
Q008	1	1	1	HT315852B0	Transistor, 2SC1585 O or Y
Q009	1	1	1	HT109082B0	Transistor, 2SA908 O or Y
Q010	1	1	1	HT109082B0	Transistor, 2SA908 O or Y
Q011	1	1	1	HT109082B0	Transistor, 2SA908 O or Y
Q012	1	1	1	HT109082B0	Transistor, 2SA908 O or Y
Q013	1	1	1	HT109082B0	Transistor, 2SA908 O or Y
Q014	1	1	1	HT109082B0	Transistor, 2SA908 O or Y
Q015	1	1	1	HV00005080	Varistor, STV-3HY
Q016	1	1	1	HV00005080	Varistor, STV-3HY
W001	1	1	1	YC02400250	AC Cord
W001	1	1	1	YC01900030	AC Cord
7906	1	1	1	2218103500	Pointer K

12. TECHNICAL SPECIFICATIONS

[FOR U.S.A. MODEL ONLY]

AMPLIFIER SECTION:

RATED POWER OUTPUT, MINIMUM CONTINUOUS AVERAGE POWER PER CHANNEL, BOTH CHANNELS DRIVEN 185 W
 POWER BAND 20 Hz to 20 kHz
 TOTAL HARMONIC DISTORTION 0.05%
 LOAD IMPEDANCE 8 ohms
 RATED POWER OUTPUT, MINIMUM CONTINUOUS AVERAGE POWER PER CHANNEL, BOTH CHANNELS DRIVEN 240 W
 POWER BAND 20 Hz to 20 kHz
 TOTAL HARMONIC DISTORTION 0.1%
 LOAD IMPEDANCE 4 ohms

I.M. Distortion
 (I.H.F. method, 60 Hz and 7 kHz mixed 4:1 at rated power output)
 at 8 ohm load impedance 0.05%
 at 4 ohm load impedance 0.1%
 Damping Factor (at 20 Hz) 60
 Sensitivity (at MAIN IN) 1.5 V
 Impedance (at MAIN IN) 40 kohms
 Frequency Response for Power Amp Only
 (at 1 Watt output, 20 Hz to 20 kHz) ±0.2 dB

PREAMPLIFIER SECTION:

Phono
 Input Overload at 1 kHz 200 mV
 Equivalent Input Noise 1.0 μV
 Dynamic Range
 (Dynamic Range is the ratio of input overload to equivalent input noise) 106 dB
 Input Sensitivity 1.8 mV
 Input Impedance 47 kohms
 Frequency Response, RIAA 20 Hz to 20 kHz ±0.25 dB
 Signal-to-Noise Ratio
 (at rated output and 7.75 mV input) 79 dB
 High Level (Aux and Tape)
 Input Sensitivity 180 mV
 Input Impedance 47 kohms
 Frequency Response
 (includes power amp) 10 Hz to 50 kHz, ±1.0 dB
 Signal-to-Noise Ratio
 (ref. to rated output and 775 mV input) 92 dB
 Output Levels
 Tape Out (ref. 7.75 mV at Phono inputs) 775 mV
 Pre-Out (ref. 180 mV at Aux inputs) 1.5 V
 (ref. 500 mV at Aux inputs, main amp disconnected) 4.2 V
 Output Impedance
 Tape Out 500 ohms
 Pre-Out 50 ohms

FM TUNER SECTION:

Sensitivity
 IHF Usable 8.75 dBf (1.5 μV)
 IHF 50 dB Quieting (mono) 12.1 dBf (2.2 μV)
 (stereo) 33.2 dBf (25 μV)
 Quieting Slope (Mono)
 RF Input for 30 dB Quieting 6.8 dBf (1.2 μV)
 Quieting at:
 20 dBf (5.5 μV) 58 dB
 25 dBf (10 μV) 66 dB
 40 dBf (55 μV) 78 dB
 65 dBf (1000 μV) 80 dB
 Quieting Slope (Stereo)
 Quieting at:
 30 dBf (17 μV) 49 dB
 40 dBf (55 μV) 62 dB
 50 dBf (173 μV) 70 dB
 65 dBf (1000 μV) 75 dB
 Distortion (Mono) at 65 dBf (1000 μV)
 100 Hz 0.15%
 1000 Hz 0.1%
 6000 Hz 0.15%
 Distortion (Stereo) at 65 dBf (1000 μV)
 100 Hz 0.35%
 1000 Hz 0.2%
 6000 Hz 0.3%

Distortion (Mono and Stereo)
 at 50 dB Quieting, 1000 Hz 0.4%
 Hum and Noise
 at 65 dBf (1000 μV)
 Mono -80 dB
 Frequency Response
 30 Hz to 15 kHz
 Mono +0.2, -1.0 dB
 Stereo +0.2, -1.0 dB
 Capture Ratio
 at 45 dBf (100 μV) 1.0 dB
 at 65 dBf (1000 μV) 1.0 dB
 Alternate Channel Selectivity 85 dB
 Spurious Response Rejection 120 dB
 Image Response Rejection 120 dB
 I.F. Rejection (Balanced) 120 dB
 A.M. Suppression 60 dB
 Stereo Separation
 100 Hz 45 dB
 1000 Hz 50 dB
 10 kHz 42 dB
 Subcarrier Rejection 75 dB

AM TUNER SECTION:

IHF Usable Sensitivity 10 μV
 Distortion (THD), 30% Modulation 0.4%
 Signal-to-Noise Ratio 55 dB
 Alternate Channel Selectivity 50 dB
 Image Rejection 80 dB
 Spurious Response Rejection 90 dB
 I.F. Rejection 80 dB

GENERAL:

Power Requirements 120 V AC, 60 Hz
 Power Consumption at rated output, both channels operating 670 W
 Idling Power (Volume Control at zero) 75 W
 Dimensions:
 Panel Width 490 mm (19-1/4")
 Panel Height 177 mm (7")
 Depth 438 mm (17-1/4")
 Weight:
 Unit alone 26 kg (57.2 lbs)
 Packed for shipment 28 kg (61.6 lbs)

[FOR EUROPEAN MODEL ONLY]

AUDIO SECTION:

POWER OUTPUT AT 1% DISTORTION	260 W
RATED POWER OUTPUT, 1 kHz	260 W
TOTAL HARMONIC DISTORTION AT RATED POWER OUTPUT, 1 kHz	0.1%
I.M. DISTORTION AT RATED POWER OUTPUT (I.H.F. METHOD, 300 Hz AND 10 kHz MIXED 4:1 AT RATED POWER OUTPUT)	0.1%
POWER BANDWIDTH (½ RATED POWER OUTPUT)	5 Hz — 30 kHz
LOAD IMPEDANCE	4 ohms
POWER OUTPUT AT 1% DISTORTION	200 W
RATED POWER OUTPUT, 1 kHz	200 W
TOTAL HARMONIC DISTORTION AT RATED POWER OUTPUT, 1 kHz	0.05%
I.M. DISTORTION AT RATED POWER OUTPUT (I.H.F. METHOD, 300 Hz AND 10 kHz MIXED 4:1 AT RATED POWER OUTPUT)	0.1%
POWER BANDWIDTH (½ RATED POWER, OUTPUT)	5 Hz — 30 kHz
LOAD IMPEDANCE	8 ohms

Damping Factor	
8 ohms	45
4 ohms	20
Frequency Response	
Phono ±2 dB	±0.5 dB
Aux ±1.5 dB	±0.5 dB
Main In ±1.5 dB	±0.2 dB
Signal-to-Noise Ratio, 1 kHz	
Phono	50 dB
Aux	50 dB
Main In	55 dB
Input Terminals	
Phono: Input Impedance	47 kohms
Input Sensitivity	1.8 mV
Overload Margin (Above rated input voltage)	41 dB
Aux: Input Impedance	47 kohms
Input Sensitivity	180 mV
Overload Margin (Above rated input voltage)	60 dB
Phono Equivalent Input Noise	1.0 µV
Phono Dynamic Range (Ratio of input overload to equivalent input noise)	106 dB
Phono Input Capacitance	100 pF
Channel Balance	
Phono 0 — -40 dB	2.5 dB
Aux 40 Hz — 16 kHz	2.0 dB
Interchannel Crosstalk	
Phono 1 kHz	43 dB
250 Hz — 10 kHz	40 dB
Aux 1 kHz	55 dB
250 Hz — 10 kHz	45 dB
Intersource Crosstalk (Worst Point)	
1 kHz	55 dB
250 Hz — 10 kHz	43 dB
Output Voltage, 1 kHz	
Tape Out	775 mV
Pre Out	1.5 V
Output Impedance, 1 kHz	
Tape Out	500 ohms
Pre Out	50 ohms
Headphone Jack Load Impedance	4 ohms or more (200, 400 ohms acceptable)

FM TUNER SECTION:

Frequency Range	87.5 — 108 MHz
Usable Sensitivity 40 kHz Deviation, 98 MHz	
Mono, S/N 26 dB	1.3 µV
Stereo, S/N 46 dB	35 µV
Alternate Channel Selectivity, 98 MHz ±300 kHz	72 dB
Image Response Rejection, 98 MHz	120 dB
IF Rejection, 98 MHz	110 dB
Spurious Response Rejection, 98 MHz	110 dB
AM Suppression, 98 MHz	65 dB
Signal-to-Noise Ratio, 98 MHz	
Unweighted: Mono	73 dB
Stereo	70 dB
Weighted: Mono	78 dB
Stereo	71 dB
Pilot Signal & Subcarrier Rejection	
19 kHz	65 dB
38 kHz	75 dB

Total Harmonic Distortion, 98 MHz	
Mono	0.08%
Stereo	0.1%
Frequency Response	
30 Hz — 15 kHz	+0.2, -1.0 dB
Separation	
250 Hz — 6.3 kHz	47 dB
6.3 — 12.5 kHz	40 dB
Channel Balance	0.1 dB
Output Voltage, 1 kHz	910 mV
Output Impedance, 1 kHz	600 ohms
Acceptable Load Impedance, 1 kHz	47 kohms
Antenna Terminals	
Balanced	300 ohms
Unbalanced	75 ohms

AM TUNER SECTION:

Frequency Range	515 — 1650 kHz
Usable Sensitivity (26 dB S/N 30% Mod., 1 MHz)	15 µV
Selectivity, 1 MHz ±9 kHz	27 dB
Image Rejection, 1 MHz	80 dB
IF Rejection, 1 MHz	50 dB
Spurious Response Rejection, 1 MHz	90 dB
Signal-to-Noise Ratio, 1 MHz	55 dB
Frequency Response, 1 MHz ±3 dB	40 Hz — 2.3 kHz
Total Harmonic Distortion, 1 MHz	0.4%

GENERAL:

Power Requirements	220 V AC, 50 Hz
(E and N versions are featuring an external voltage selector for use on 110/120/240 V. Other versions can be converted by a qualified technician to operate on 110/120/240 V.)	
Power Consumption at Rated Output, Both Channels	
Operating	700 W
Idling Power	70 W
Semiconductor Complement	
Integrated Circuits	10
Transistors	122
Diodes	106
Field Effect Transistors	4
Dimensions	
Panel Width	19-1/4" (490 mm)
Panel Height	7" (177 mm)
Depth	17-1/4" (438 mm)
Weight	
Unit alone	58.3 lbs (26.5 kg)
Packed for shipment	62.7 lbs (28.5 kg)

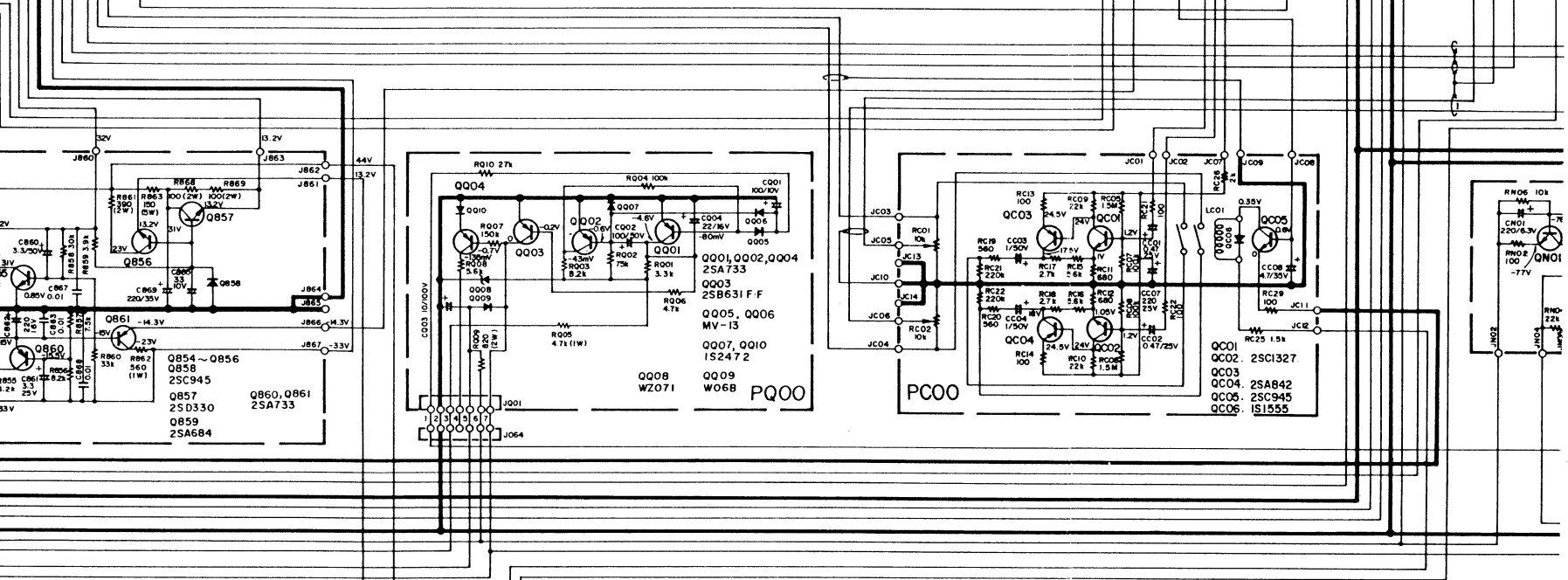
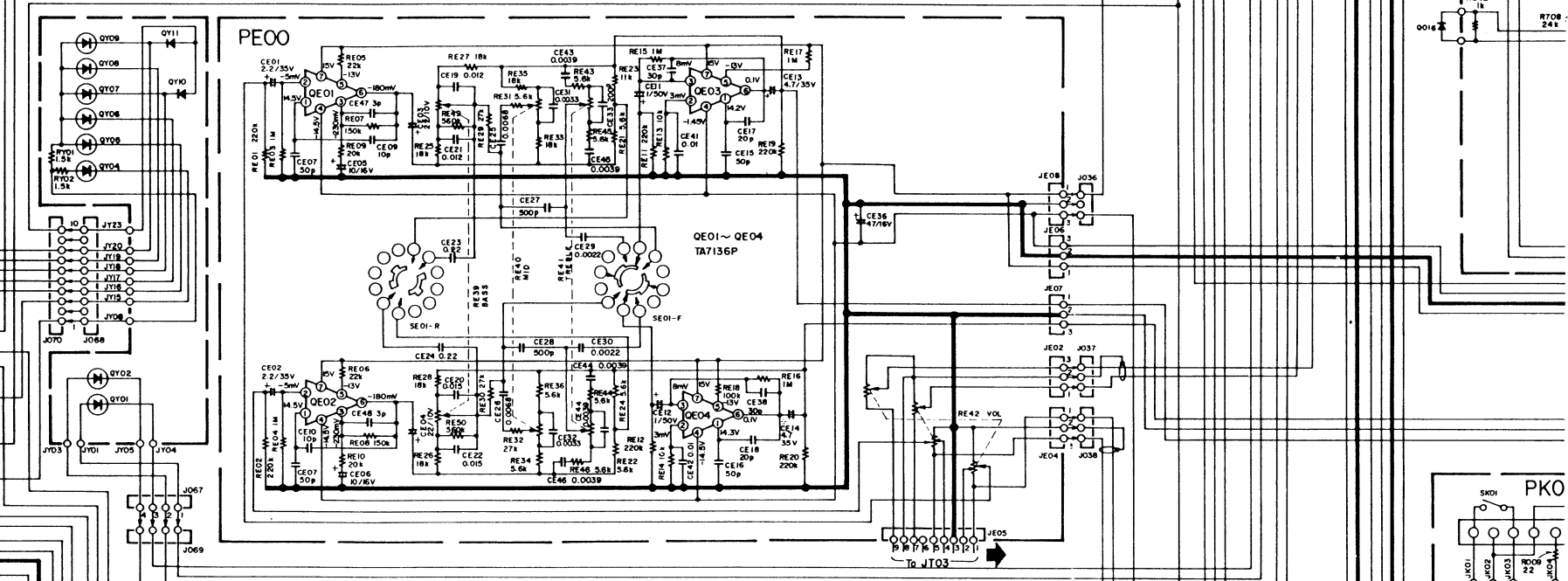
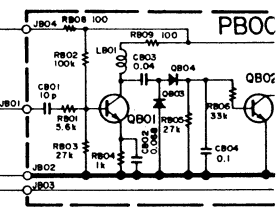
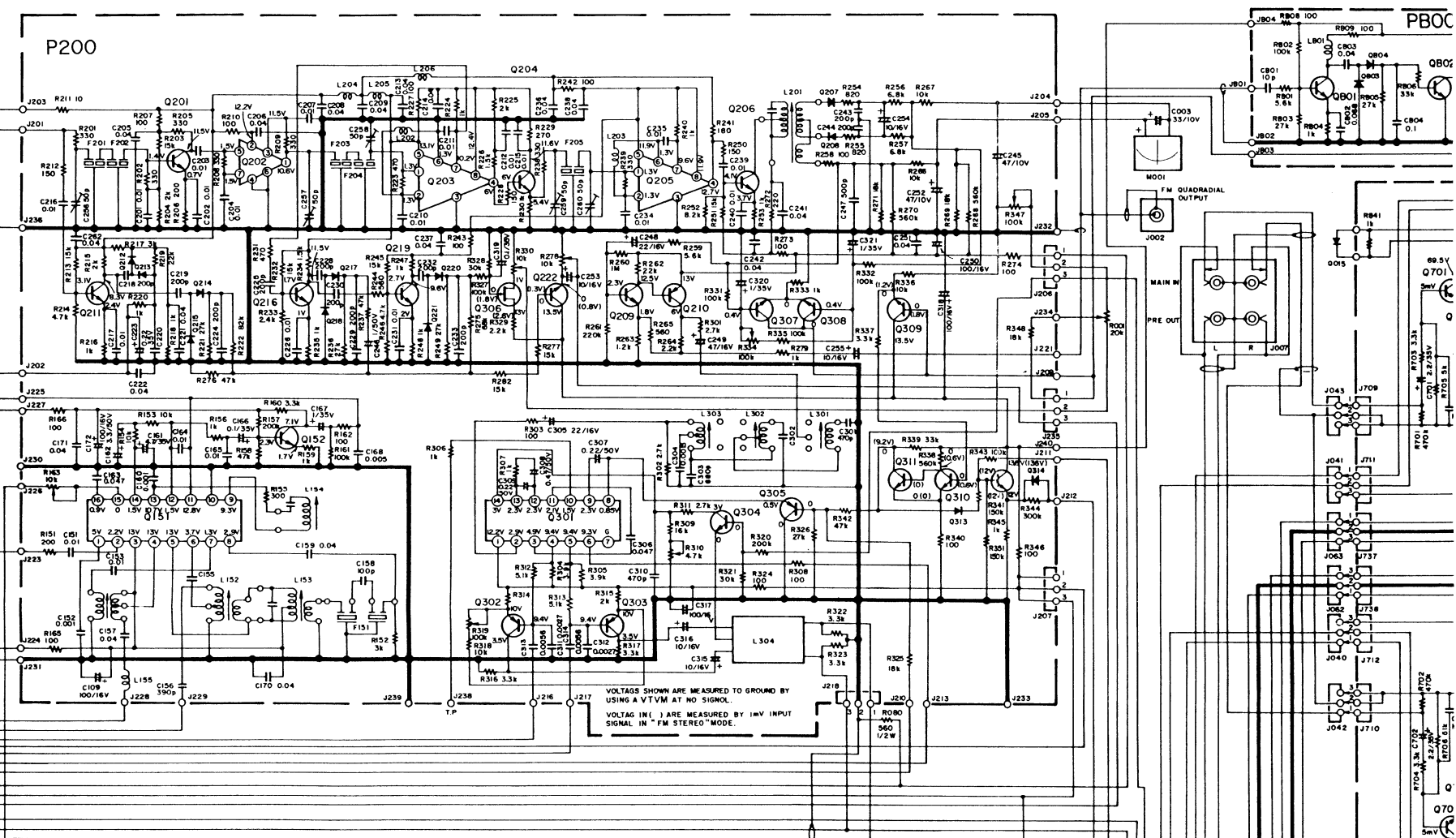

59
301P

- Q151 HA1197
- Q152, Q209 2SC1327
- Q201 2SC1047
- Q202 JPC55H
- Q203, Q205 LA1222
- Q204, Q206, Q211 Q216, Q219 2SC829
- Q207, Q208, Q212, Q215 Q217, Q218, Q220, Q221 2A090
- Q210, Q302, Q303 2SA842
- Q222, Q304, Q310~Q312 2SC945
- Q301 HA1156
- Q305 Q306 2SA733 2SK30

P200

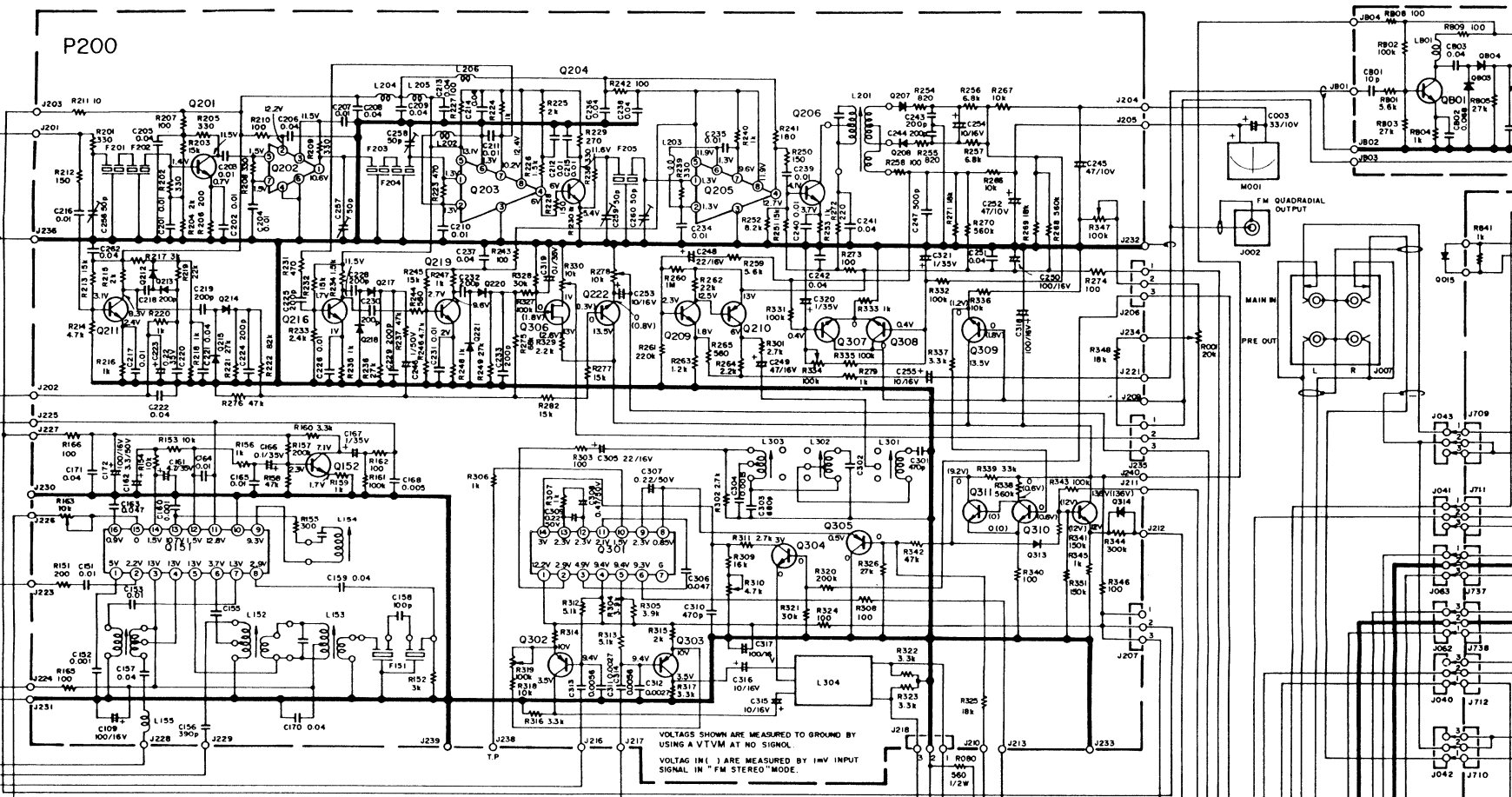

PE00

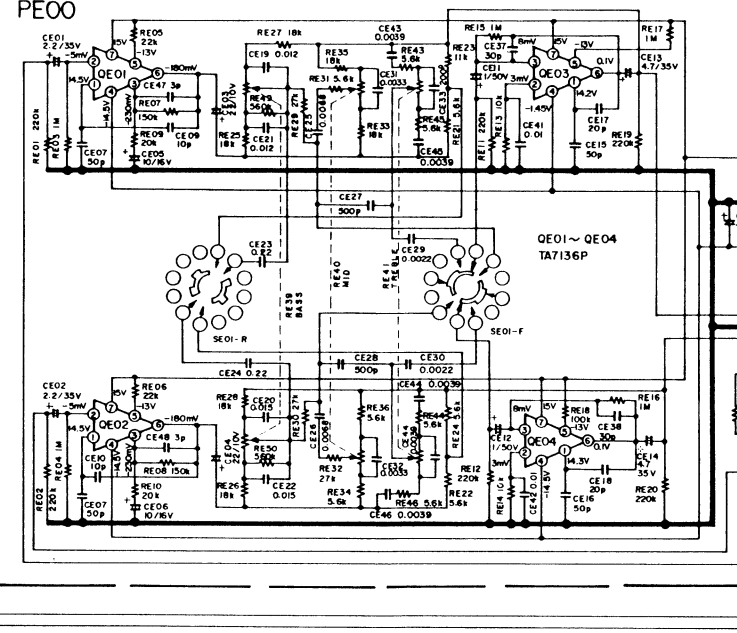

PZ00

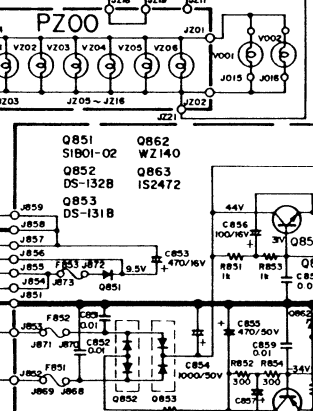

P850

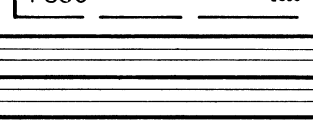

Q004

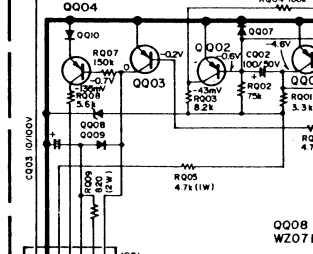

PC00

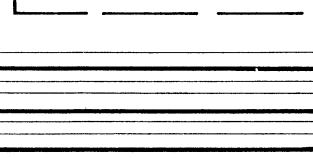

PK

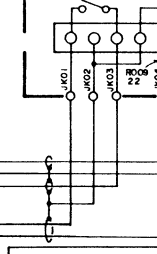

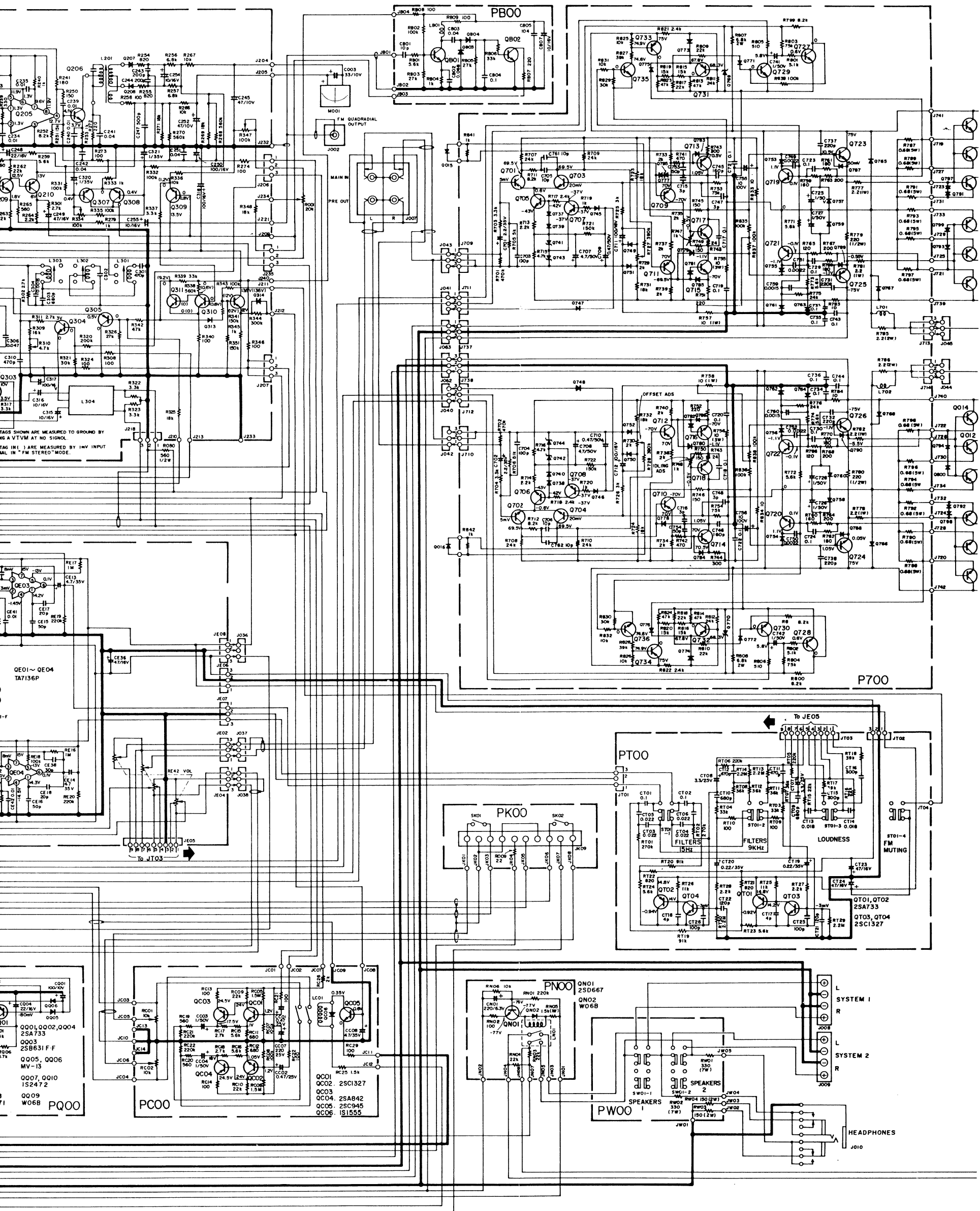

SCHEMATIC DIAGRAM - EUROPE

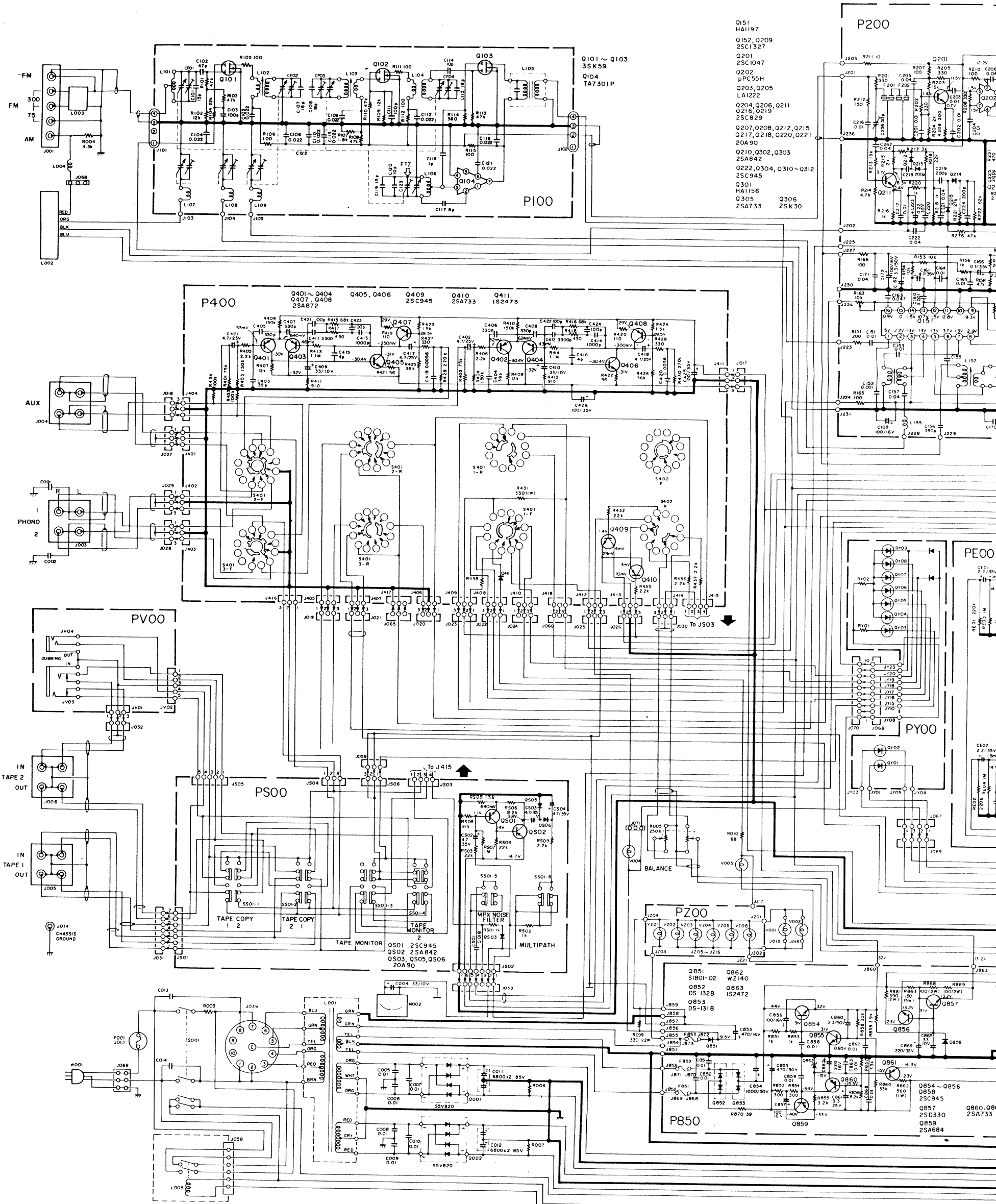

- Q151 HA1197
- Q152, Q209 2SC1327
- Q201 2SC1047
- Q202 μ PC55H
- Q203, Q205 LA1222
- Q204, Q206, Q211 2SC829
- Q216, Q219 2SC829
- Q207, Q208, Q212, Q215 2A842
- Q217, Q218, Q220, Q221 20A90
- Q210, Q302, Q303 2SA842
- Q222, Q304, Q310~Q312 2SC945
- Q301 HA1156
- Q305 2SA733
- Q306 2SK30

P200

Marantz 34P

- Q151 HA1197
- Q152, Q209 25C1327
- Q201 25C1047
- Q202 JPC55H
- Q203, Q205 LA1222
- Q204, Q206, Q211 Q216, Q219 25C829
- Q207, Q208, Q212, Q215 Q217, Q218, Q220, Q221 20A90
- Q210, Q302, Q303 25A842
- Q222, Q304, Q310~Q312 25C945
- Q301 HA1156
- Q305 Q306
- 25A733 25K30

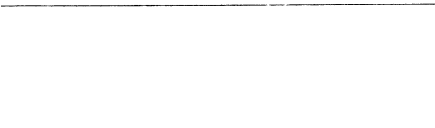
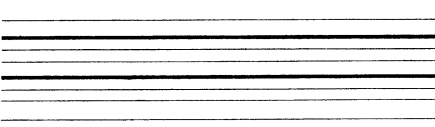
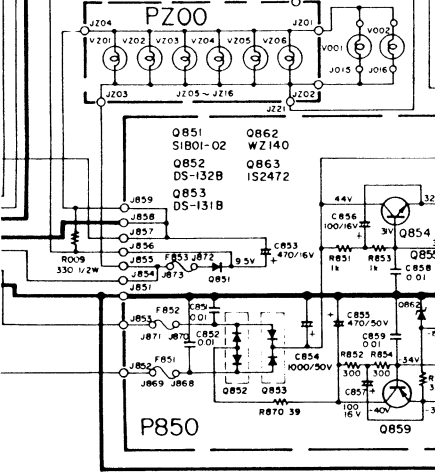
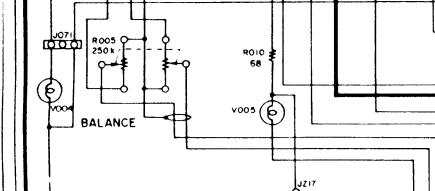
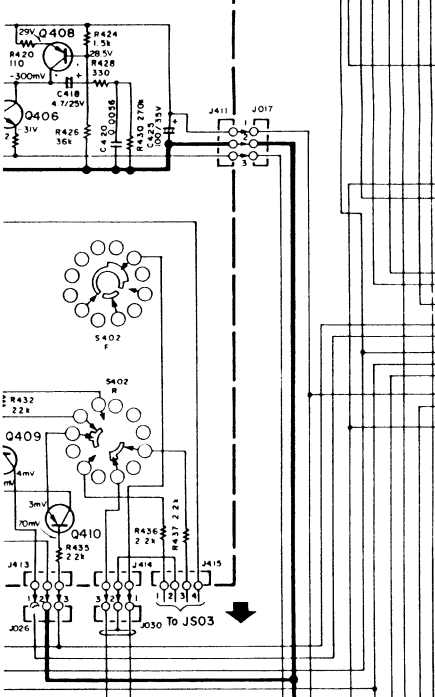
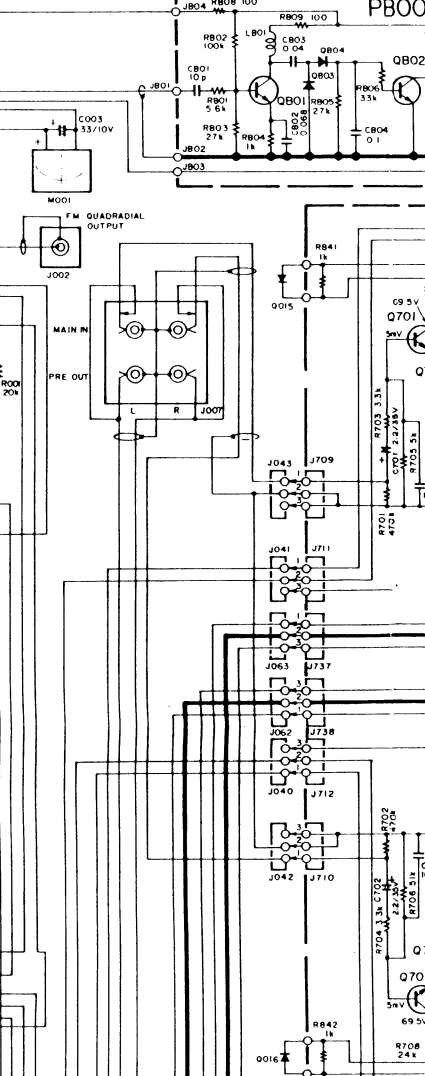
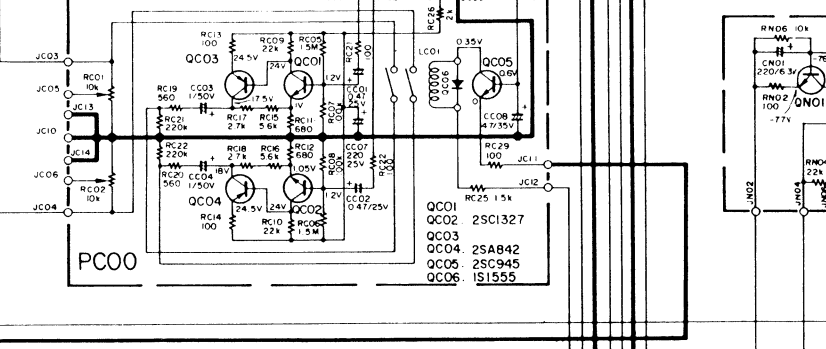
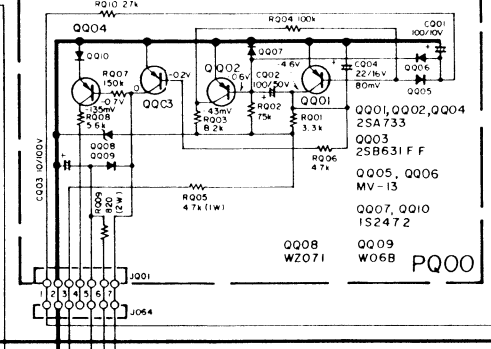
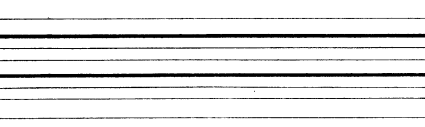
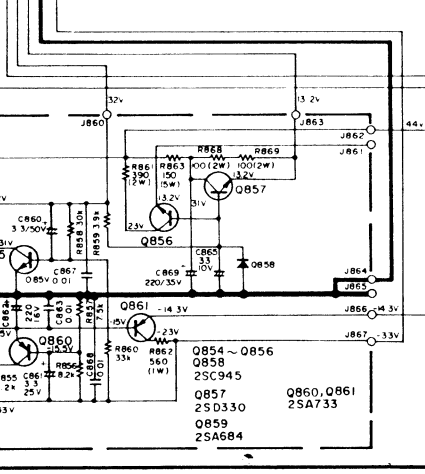
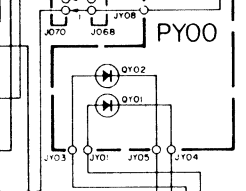
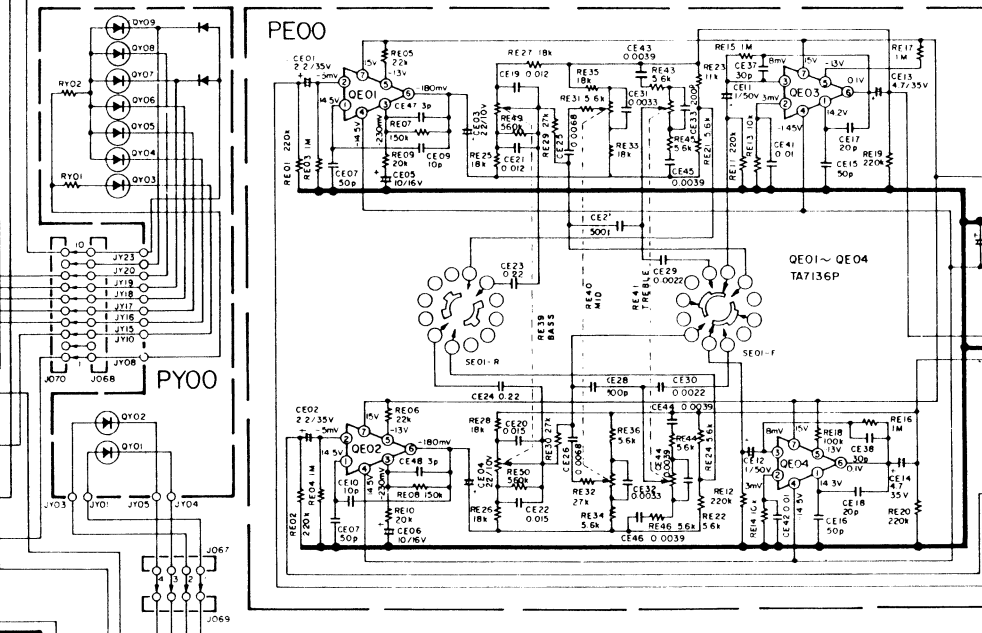
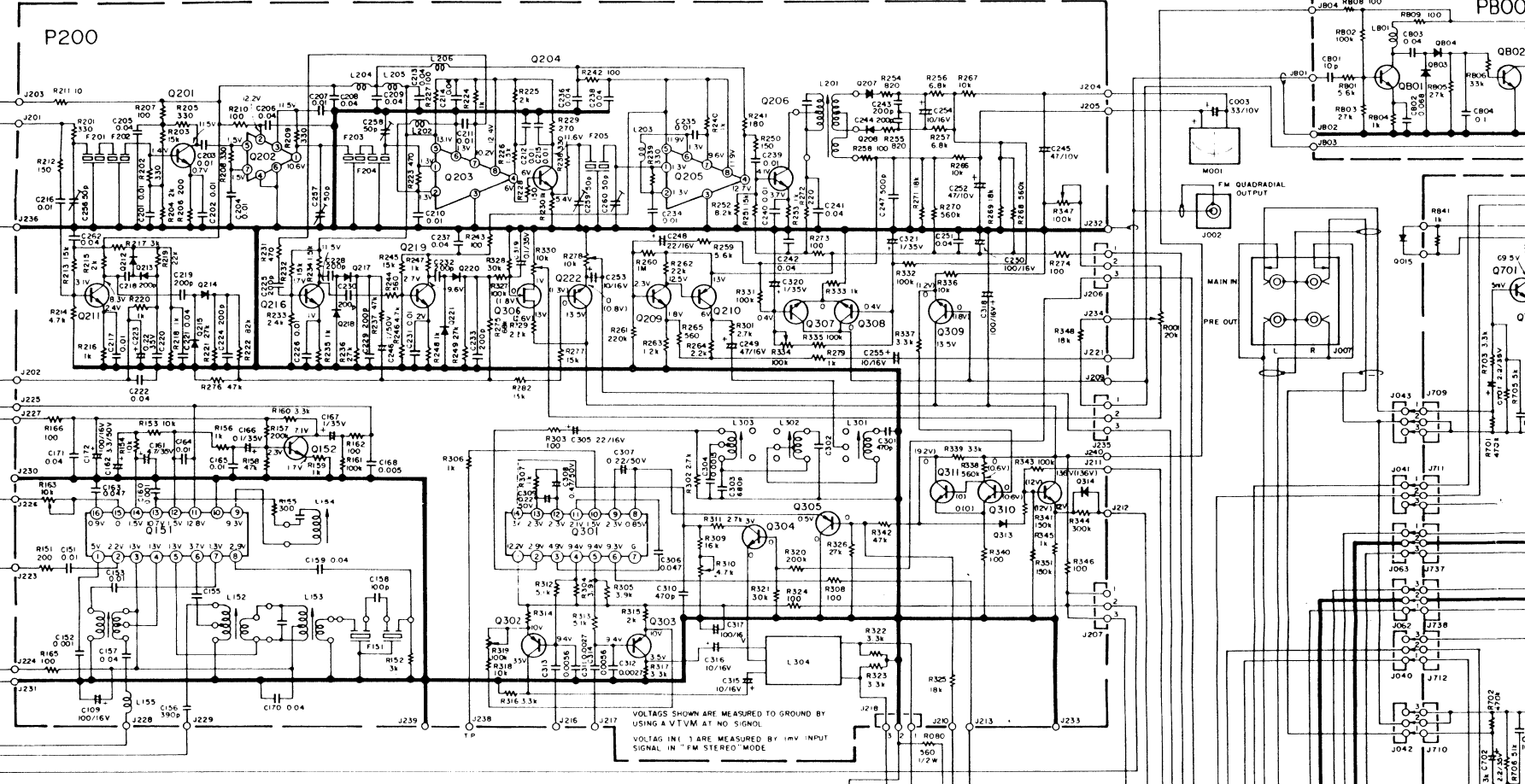

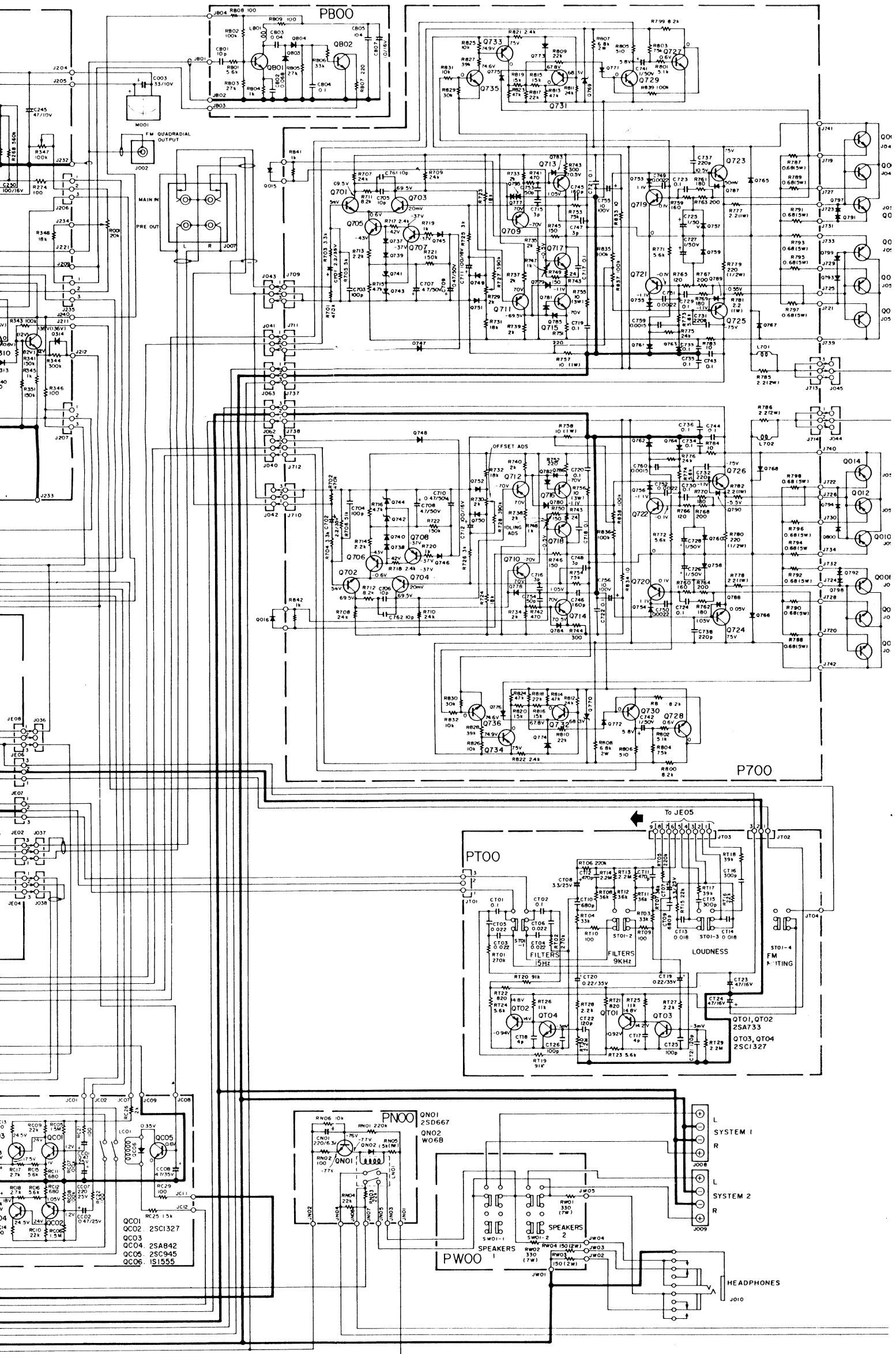



marantz

MARANTZ CO., INC. · P.O. BOX 577 · CHATSWORTH, CALIFORNIA · 91311



A WHOLLY-OWNED SUBSIDIARY OF SUPERSCOPE INC., CHATSWORTH, CALIFORNIA · 91311

DOLBY is a trademark of Dolby Laboratories, Inc.