

EQUIPMENT ITEM	MANUFACTURER AND MODEL NO. OR EQUIVALENT	USE
Distortion Analyzer (capable of measuring 0.02% THD)	Sound Technology Model 1700A or Hewlett Packard Model 331A or 333A	Measure total harmonic distortion of preamp
AC Voltmeter (capable of measuring 30 mV (noise) accurately)	Hewlett Packard Model 400F	Measure preamp output voltage
Audio Oscillator residual distortion less than 0.02%	Sound Technology Model 1700A or Weston Model CVO-100P	Audio signal source
Oscilloscope	Tektronix Model 503; Data Model 555	Waveform analysis and troubleshooting
VTVM	RCA Senior Volt-Ohm-yst Model 555; Simpson 312	Voltage and resistance measurements
Variable Autotransformer (0-140 V AC)	Powerstat Model 116B	Controls A.C. line voltage to preamp
AC Wattmeter 0-150 W	Simpson Model 1379 (Catalog No. 10970)	Monitor preamp power consumption
Line Voltmeter 0-150 V AC	Simpson Model 1359 (Catalog No. 10320)	Monitor A.C. line voltage to preamp
AC Power Control Box (optional)	Fabricated in accordance with Figure 4.	Monitor line voltage and power consumption
Phono Shorting Plug (4)	Phono shorting plug with 600 ohm resistor across center pin and shell	Short preamp input to eliminate noise pickup
Noise Filter (20 Hz to 20 KHz, 12 dB per octave roll off, less than 3 microvolts residual noise input)	Commercial grade.	Measure noise.

Table 1. Recommended Test Equipment

C. POWER CONSUMPTION VERIFICATION

1. Plug Model 3600 AC Plug into AC Control Box outlet.
2. Set LINE Switch (AC Power Control Box) to VARIABLE.

3. Observing Wattmeter, slowly rotate autotransformer control CW to 120 VAC. If Wattmeter indicates more than 7 W at any time, (or fails to indicate at all), shut off AC power and refer to the Trouble Analysis section.

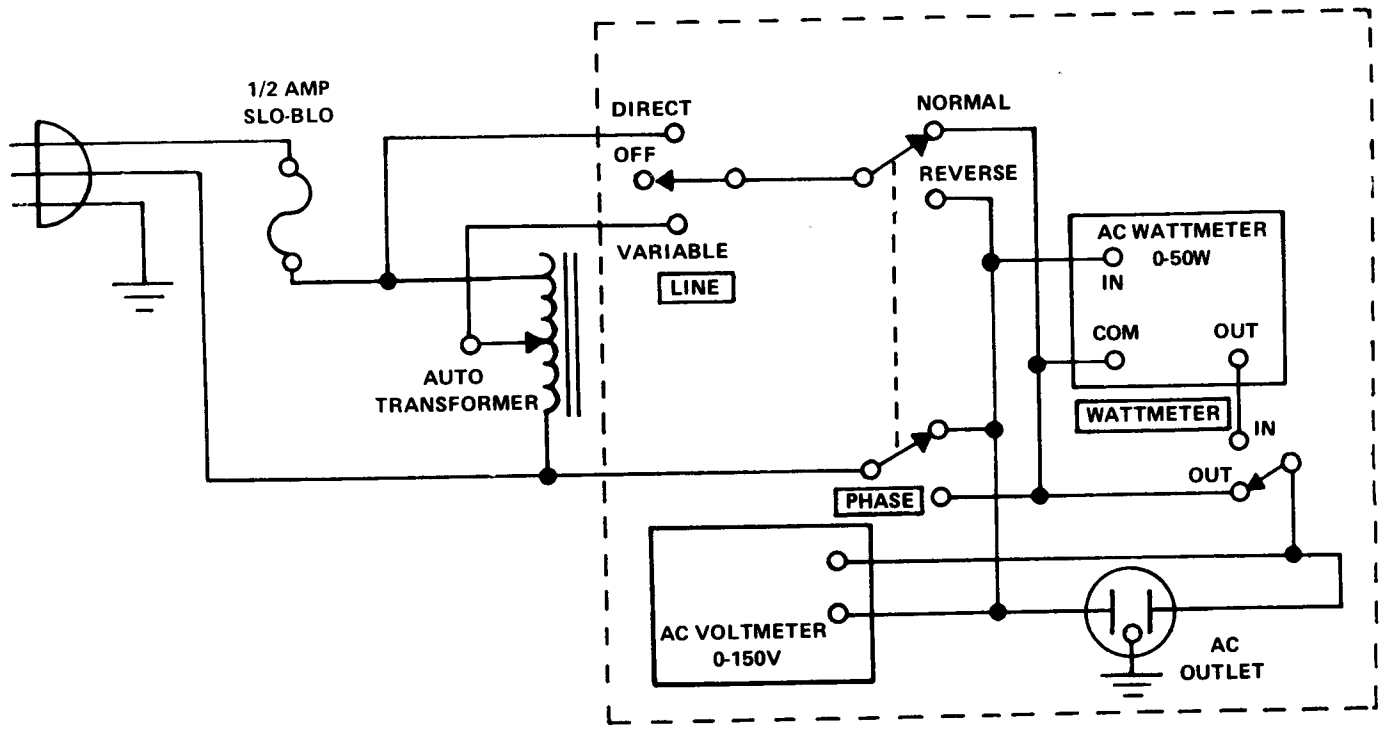

AC Power Control Box Connection Diagram

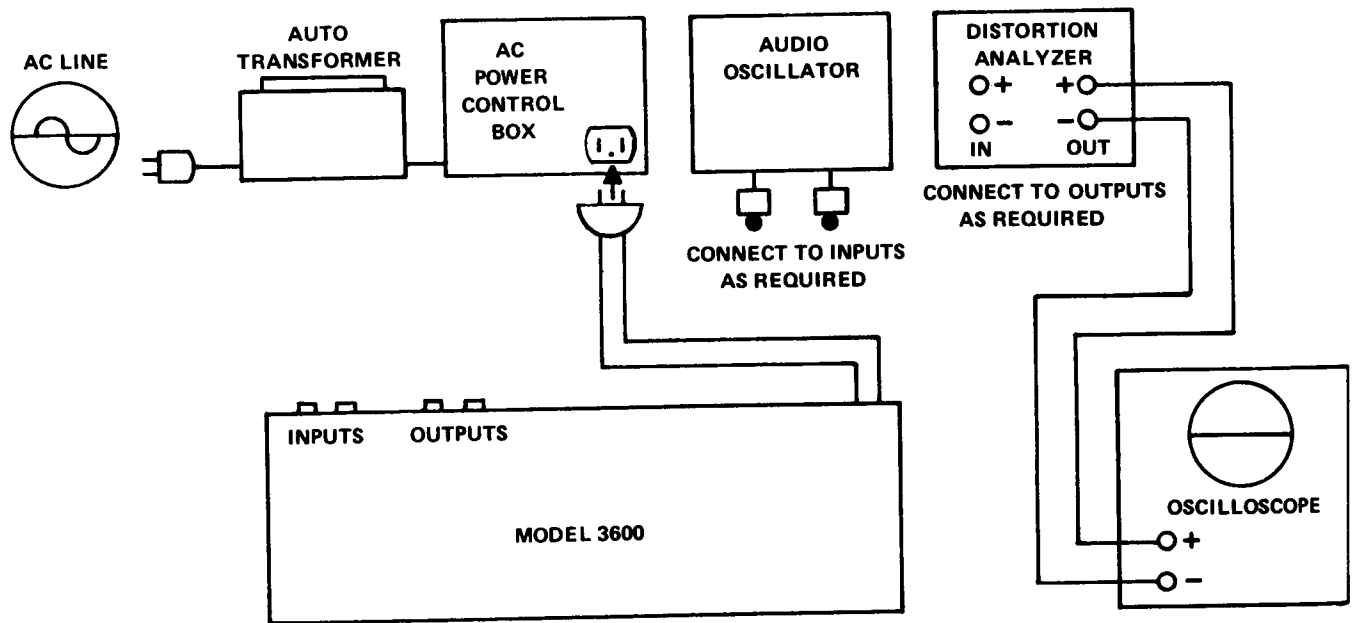

Test Equipment Connection Diagram

**D. FUNCTIONAL TESTS**

Perform functional tests on unit to establish the operation of all inputs, outputs and controls as specified. Reset Model 3600 controls to their "Normal" positions upon completion of the functional test.

1. For low level (Phono or Mic) input tests, apply a 1 kHz, 10 mV audio signal to Phono Input. Depress PHONO Selector Pushswitch.
2. Set Distortion Analyzer controls for AC VTVM and monitor output at SCOPE or TAPE OUTPUT Jack. Output should be approximately 1.0 V rms.
3. Without changing generator output level, disconnect and reconnect to Mic Input. Depress MIC Selector Pushswitch. Output should remain at approximately 1.0 V rms.
4. For high level (Tuner, Aux, or Tape) inputs, turn preamp power off, set generator to 1 kHz, 300 mV rms output. Connect to TUNER Input. Reconnect Distortion Analyzer to PREAMP Output.
5. Turn preamp power on, set VOLUME to maximum, depress TUNER Selector Pushswitch. Output should be approximately 3.0 V rms.
6. Without changing any connections other than inputs, check AUX, TAPE 1, and TAPE 2 Inputs as described in Step 5. Output level should remain at approximately 3.0 V rms.

**E. MAXIMUM VOLTAGE OUTPUT**

1. Depress AUX Selector pushswitch. Connect generator to AUX Input. Monitor signal at PREAMP OUTPUT with oscilloscope and distortion analyzer controls set for AC VTVM. Set VOLUME to MAX.
2. Set generator frequency to 1 kHz and increase generator output to the point of just below clipping. VTVM should indicate at least 9.0 V rms.

**F. TOTAL HARMONIC DISTORTION (THD)**

1. With preamp VOLUME set to maximum, check THD of AUX Input at 20 Hz, 2 kHz, and 20 kHz (3.0 V rms output). THD should be less than 0.025 percent.
2. Change input to PHONO and depress PHONO Selector pushswitch. Adjust generator for 3.0 V rms at TAPE OUTPUT. Check THD at 20 Hz, 2 kHz, and 20 kHz. THD should be less than 0.025 percent.

**G. HUM AND NOISE**

1. Insert 600-ohm phono shorting plug into each PHONO and AUX INPUT jack. Switch in bandpass filter control.
2. Turn VOLUME control CW up to maximum and depress PHONO Selector pushswitch. Noise output should indicate less than 78 microvolts at TAPE OUTPUT.
3. Depress AUX Selector pushswitch. Noise output should indicate less than 30 microvolts at PREAMP OUTPUT.

**H. FREQUENCY RESPONSE (PHONO/MIC)**

Refer to Figure 6. RIAA Equalization Curve and Standards to verify unit conformance.

1. For Phono frequency response apply a 1 kHz signal to PHONO INPUT. Connect AC VTVM to PREAMP OUTPUT. Set generator output for 0 dB indication on VTVM.
2. Check output level at the following frequencies  $\pm 0.5$  dB:  
20 Hz ..... - 19.30 dB  
100 Hz ..... + 13.11 dB  
400 Hz ..... + 3.81 dB  
2 kHz ..... - 2.61 dB  
10 kHz ..... - 13.75 dB  
20 kHz ..... - 19.60 dB
3. For Mic frequency response apply a 1 kHz signal to MIC INPUT. Depress MIC Selector pushswitch. Set generator output to 0 dB as measured at PREAMP OUTPUT.
4. Reduce generator frequency to 30 Hz. Output should be 0 dB ( $\pm 0.75$  dB).
5. Increase generator frequency to 11.5 kHz. Output should be 0 dB (+ 0 dB, - 4 dB).



## TROUBLE ANALYSIS

This section is included to assist in locating troubles that may be difficult to isolate. Normal troubleshooting techniques (point-to-point signal tracing and oscilloscope analysis) are assumed in isolating problems.

**NOTE:** Performance verification is necessary following any repair.

Table 2. lists possible symptoms and causes if a Model 3600 malfunctions. We do not attempt to point up all potential problems and their remedies since the service technician is capable of recognizing most. We attempt to aid the service technician in isolating problems from the unit level down to a detail part.

All references in this section will be made to Figures 1, 2, and 3.

SYMPTOMS	PROBABLE CAUSE
No primary power consumption	<ol style="list-style-type: none"> <li>1. Open A.C. input circuit, line cord, fuse, power switch or transformer</li> <li>2. Power supply circuit defective.</li> </ol>
Excessive primary power consumption	<ol style="list-style-type: none"> <li>1. Short in A.C. input circuit</li> <li>2. Short in A.C. secondary circuit, pilot lamp circuit, or power supply.</li> </ol>
No signal output both channels	No D.C. supply voltage to amplifiers, +Vcc, -Vcc or neither, caused by broken supply lines, defective power supply lines or defective power transformer.
No signal output in any condition	<ol style="list-style-type: none"> <li>1. Short in input circuit</li> <li>2. Open input circuit, Program Selector, Tape Monitor, Mode, Volume or Balance Switch</li> <li>3. Defective X10 amplifier and/or filter amplifier</li> <li>4. Output circuit open or shorted.</li> </ol>
No signal output in low level inputs	<ol style="list-style-type: none"> <li>1. Shorted input circuit to phono amplifier</li> <li>2. Open input circuit</li> <li>3. Defective phono amplifier</li> <li>4. Phono amplifier output circuit open</li> <li>5. Short in phono amplifier output circuit</li> <li>6. Phono amplifier oscillating (VHF) because of open (or shorted) feedback circuit through Program Selector Switch.</li> </ol>
No signal output with TONE in or LOUDNESS in	<ol style="list-style-type: none"> <li>1. Defective tone amplifier</li> <li>2. Open tone amplifier output circuit</li> <li>3. Defective Tone or Loudness switch.</li> </ol>
Low gain in low level inputs	Defective phono amplifier.
Low gain with TONE in	Defective tone amplifier.
High distortion in any condition	<ol style="list-style-type: none"> <li>1. X10 amplifier defective</li> <li>2. Excessive output loading</li> <li>3. Filter amplifier defective.</li> </ol>

**Trouble Analysis**

SYMPTOMS	PROBABLE CAUSE
High distortion in low level inputs	1. Defective phono amplifier 2. Hum pickup in the input circuit .
High distortion with TONE in	Defective tone amplifier .
Excessive noise in low level inputs	1. Defective phono amplifier 2. Open feedback circuit, Program Selector switch 3. Input circuit open 4. Input cable shield not grounded.
Excessive noise in high level inputs	1. Defective X10 amplifier 2. Input circuit cable shield not grounded 3. Excessive power supply ripple (hum) .
Excessive noise with TONE in	Defective tone amplifier .
Oscillation in low level inputs	1. Open input circuit 2. Open feedback circuit, program selector switch 3. Grounds intermittent or broken 4. Defective phono amplifier .
Oscillation in high level inputs	1. Defective X10 amplifier 2. Shorts in high or low filter circuits.

REFERENCE DESIGNATION	MARANTZ PART NUMBER	NOMENCLATURE
	361-1001	LINE CORD, AC
	367-1000	FUSE HOLDER, W/MTG. HDW
	565-1001	BUSHING, STRAIN RLF
	567-2000	FOOT, PLASTIC, BLK, W/FELT PAD x4
	670-4552	WASHER, F LAT NO. 6, BLK WAX x4
	671-2232	LOCKWASHER, NO. 4, SPT, BLK
	671-4330	LOCKWASHER, NO. 6, SPT, CD x2
	671-4332	LOCKWASHER, NO. 6, SPT, BLK, WAX x6
	672-5510	LOCKWASHER NO. 8 INTL T x2
	672-8816	LOCKWASHER, INTL T x4
	675-1015	FLATWASHER
	680-8726	NUT, HEX, 3/8-32 x 1/2 x4
	682-2000	SPEED NUT, J-TYPE x4
	689-1023	NUT, HEX, 3/8-32 x5
	689-2000	SPEED NUT, NO. 6, J-TYPE x4
	741-0410	SCREW, 6-32 x 1/4 L, PNH CRSHD, STL, CD x2
	741-0412	SCREW, 6-32 x 1/4 L, PNH, CRSHD, STL, BLK, WAX x2
	741-0612	SCREW, 6-32 x 3/8 PNH, CRSHD, STL, BLK, WAX x4
	769-2002	SCREW, 3MM x 35MM L, PNH, CRSHD, STL, BLK x4
	741-0612	SCREW, 6-32 x 3/8 L, PNH CRSHD, BLK, WAX x4
	799-1011	SCREW, NO. 6-20 x 1/2 L, SH MET TYPE Z, STL, BLK, WAX x4
<b>A100</b>	<b>200-2000-1</b>	<b>CONTROL BOARD COMPONENT ASSEMBLY</b>
C101, C102	* 381-2002	CAPACITOR, 10MFD +100%, -20%, 25V

REFERENCE DESIGNATION	MARANTZ PART NUMBER	NOMENCLATURE
C103, C104	386-2000	CAPACITOR, 5600PF $\pm$ 10%, 100V
C105, C106	381-2002	CAPACITOR, 10MFD +100%, -20%, 25V
DS-101	482-2000	LAMP, PILOT LIGHT
J101	360-2000	CONNECTOR, 11-PIN
J102 (PARTIAL)	360-1020	CONNECTOR, 13-PIN
J102 (PARTIAL)	360-1019	CONNECTOR, 16-PIN
J103	360-2001	CONNECTOR, 8-PIN
J104	360-2003	CONNECTOR, 7-PIN
J105,		PHONE JACK, SINGLE CLOSED
J106	360-1017	CIRCUIT, MIC
J107	360-1004	PHONE JACK, DOUBLE CLOSED CIRCUIT, DUB IN
J108	360-1005	PHONE JACK, DOUBLE OPEN CIRCUIT, DUB OUT
		<b>RESISTORS ARE OHMS <math>\pm</math> 5%, 1/4 W UNLESS OTHERWISE SPECIFIED</b>
R101,		
R102	434-4202	RESISTOR, C-F 2K
R103	420-2003	RESISTOR, VAR, 50K BALANCE
R105	420-2009	RESISTOR, VAR, 50K, DUAL VOLUME
R107,		
R108	434-5152	RESISTOR, C-F, 15K
R109,		
R110	434-4562	RESISTOR, C-F, 5.6K
R111,		
R112	434-4622	RESISTOR, C-F, 6.2K
R113		
thru	420-2002	RESISTOR, VAR, 100K, TONE
R118		



REFERENCE DESIGNATION	MARANTZ PART NUMBER	NOMENCLATURE
R119, R120, R121, R122, R123, R124, R125, R126	434-5152 434-4562 434-4682 434-5472	RESISTOR, C-F, 15K RESISTOR, C-F, 5.6K RESISTOR, C-F, 6.8K RESISTOR, C-F, 47K
S101	453-2009	SWITCH, ROTARY, 3-POSN, TAPE MONITOR
S102	453-2008	SWITCH, ROTARY, 5-POSN, MODE
S103	453-2010	SWITCH, ROTARY, 2-POSN, TONE
	132-2000	BRACKET, VARIABLE RESISTOR
	168-1016-2	SPACER, BALANCE CONTROL
	168-2006	SPACER, TONE CONTROL
	566-1020	GROMMET
	673-0122	LOCKWASHER NO. 2, EXT. TOOTH x2
	701-0412	SCREW, 2-56 x 1/4 LG, PNH, CRSHD, STL, BLK, WAX x2
	769-2001	SCREW, 3.0MM x 6.0MM LG PNH x14
A200- 300	200-2001-1	PREAMPLIFIER BOARD COMPONENT ASSEMBLY  CAPACITORS ARE $\pm 10\%$ , 100V UNLESS OTHERWISE SPECIFIED.
C201, C202, C203, C204, C205, C206, C207, C208	* 381-3001 385-1065 385-1037 381-3003	CAPACITOR, 4.7 MFD + 100%, - 20%, 25V CAPACITOR, 82PF CAPACITOR, 270PF CAPACITOR, 22 MFD + 100%, - 20%, 25V

REFERENCE DESIGNATION	MARANTZ PART NUMBER	NOMENCLATURE
C209, C210, C211, C212, C213, C214	385-2004 385-1040 385-1091	CAPACITOR, 220PF CAPACITOR, 47PF CAPACITOR, 1000PF $\pm 5\%$ , 100V
C215, C216	383-1002	CAPACITOR, .03MFD $\pm 20\%$ , 100V
C217, C218	385-1057	CAPACITOR, 3600PF $\pm 5\%$ , 100V
C219, C220, C221, C222	386-2003 383-1002	CAPACITOR, 1MFD CAPACITOR, .03MFD $\pm 20\%$ , 100V
C223 thru C226	381-3001	CAPACITOR, 4.7MFD + 100%, - 20%, 25V
C227, C228, C229, C230, C231, C232	385-2002 385-1074 381-3006	CAPACITOR, 510PF $\pm 5\%$ , 100V CAPACITOR, 68PF CAPACITOR, 100MFD + 100%, - 20%, 6.3V
C233, C234, C235, C236, C237, C238, C239	385-1046 385-1073 383-2000 383-1002	CAPACITOR, 2000PF CAPACITOR, 130PF CAPACITOR, .001MFD, GMV 300V CAPACITOR, .03MFD $\pm 20\%$ , 100V
C240 C241	NOT USED 383-1002	NOT USED CAPACITOR, .03MFD $\pm 20\%$ , 100V
C242 C243, C244, C245, C246	NOT USED 385-2003 381-2002	NOT USED CAPACITOR, 620PF CAPACITOR, 10MFD + 100%, - 20%, 25V

\* CAPACITOR P/N 381-XXXX ARE ELECTROLYTICS.



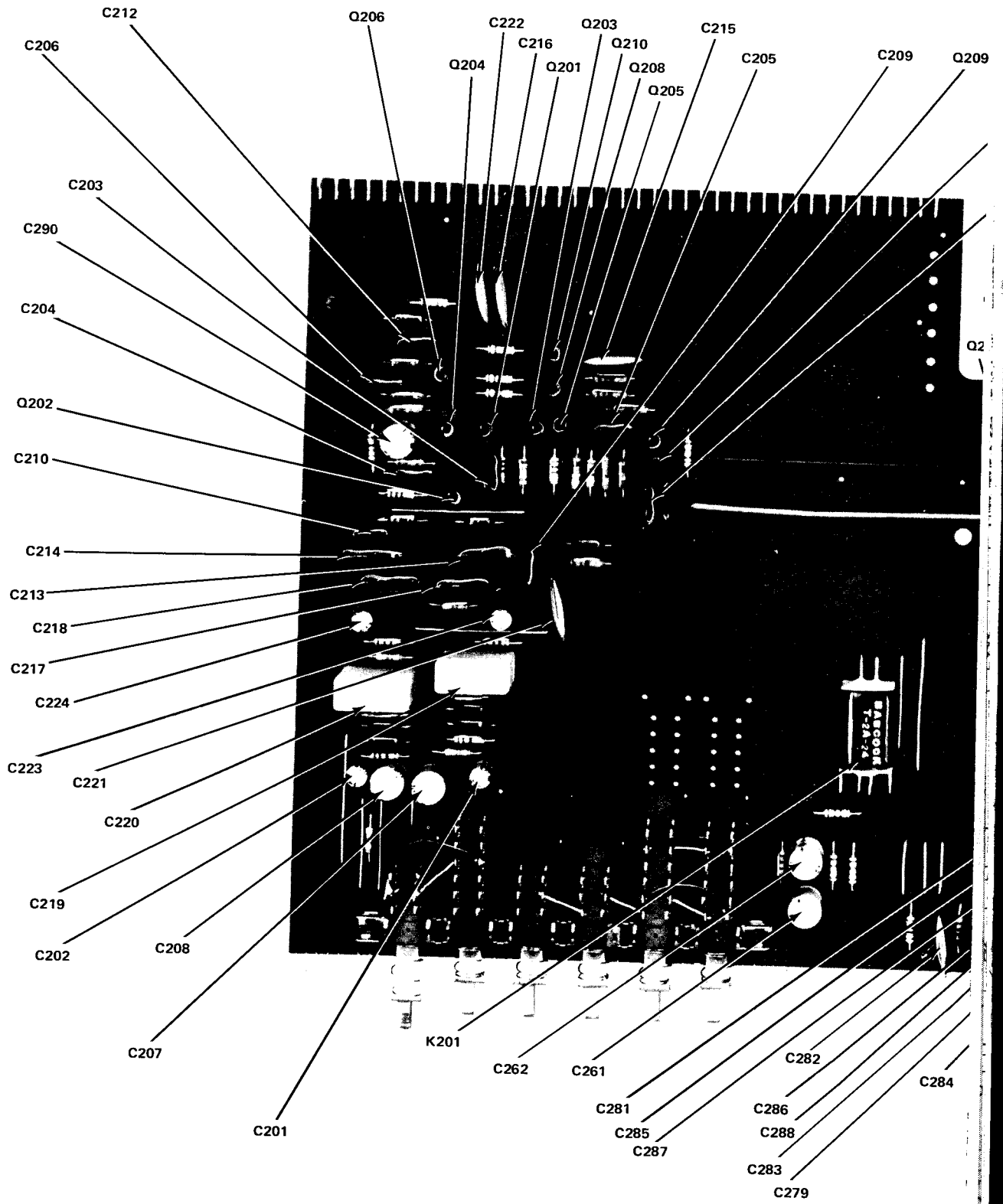

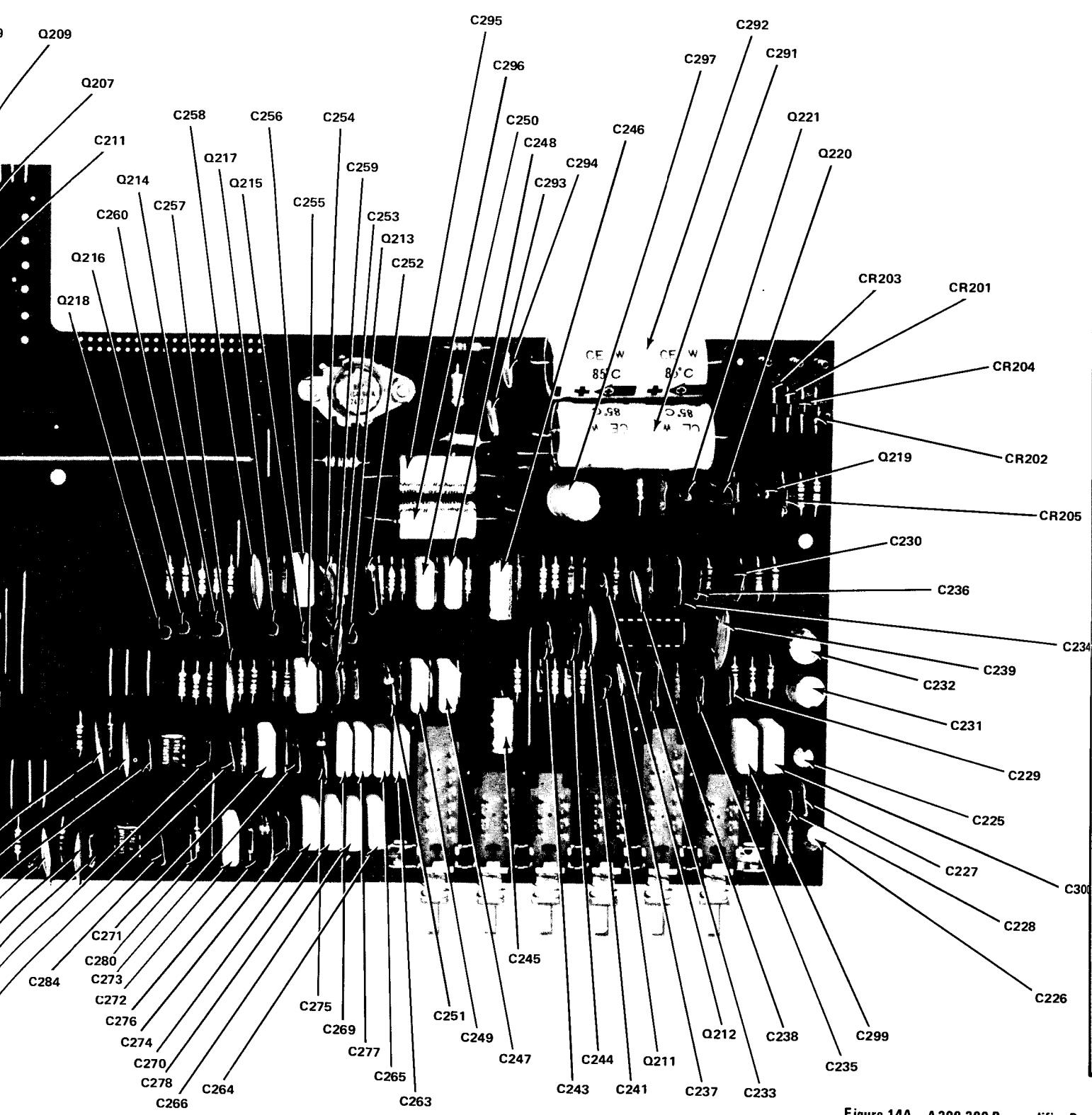

Figure 14A. A200-300 Preamplifier Box

A1

REFERENCE DESIGNATION	MARANTZ PART NUMBER	NOMENCLATURE	
	210-2000-1	PREAMPLIFIER UNIT	
	136-2001	COVER, UNIT	
	206-2000-1	FRONT DRESS PANEL ASSY (INCLUDES)	
		INSULATOR, UNIT COVER	
		PANEL, FRONT DRESS	
		SHIELD, DRESS PANEL	
		MASK, DUST, TONE CONTROL	
		MASK, DUST, BALANCE CONTROL	
		WINDOW, DRESS	
		JEWEL, PILOT LIGHT	
	174-2001	KNOB, ROUND, FUNCTION	x4
	180-1092	LABEL, UL APPROVED	
	180-2000-1	LABEL, SERIAL NUMBER (SERIALIZED)	
	551-2000	BUSHING, ROUND	x3
	551-2001	BUSHING, PHONE JACK	x5
	551-2002	BUSHING, BALANCE CONTROL	
	551-2003	BUSHING, TONE CONTROL	x6
	578-2000	FRAME, DRESS PANEL	
	578-2001	BEZEL, 6-STATION SWITCH	
	580-2009	KNOB, ROUND, TONE/ BALANCE CONTROL	x7
	580-2003	KNOB, ROUND, POWER	
	580-2004	KNOB, RECTANGULAR	x12
	580-2005	KNOB, ROUND, SPEAKER	x2
	585-1008	LABEL, CAUTION	
	769-2010	DRESS BOLT, HEX HD.	x4
	775-3242	SETScrew, 8-32 x 1/4, BLK CP	x4
	784-4112	SCREW, 6-32 x 1/4, TF, CRSHD, BLK	x20
	820-9900	SHIELD, LAMP	
A1	210-2001-1	CHASSIS ASSEMBLY	
	133-2000	CHASSIS, FRONT	
	133-2001	CHASSIS, BASE	
	133-2002	CHASSIS, REAR, MARKED	

REFERENCE DESIGNATION	MARANTZ PART NUMBER	NOMENCLATURE	
	202-2000-1	PILOT LIGHT SHIELD ASSY	
	210-2002-1	REAR CHASSIS ASSEMBLY	
C1, C3	383-1006	CAPACITOR, .01 MFD, 1400V	
C2	389-2000	CAPRISTOR, .1 MFD, 120 OHMS, 500V	
F1	451-1016	FUSE, 0.5 A, 250V	
J1-J6	360-1034	OUTLET, AC	
J7	360-1005	PHONE JACK, DOUBLE OPEN CIRCUIT	
J8, J9, J10	365-1015	CONNECTOR, FEMALE	
R1, R2	423-3332	RESISTOR, C-C, 330 OHMS ± 5%, 1W	
R3, R4	436-1103	RESISTOR, WW, 1 OHM ± 10%, 2W	
S1	452-2015	SWITCH, POWER	
S2	452-2000	SWITCH, 2-STATION, SPEAKER	
T1	440-2001	TRANSFORMER, POWER	
TB1 thru TB6	362-2000	TERMINAL BLOCK	
TB4	362-2005	TERMINAL STRIP	
TB5	362-2006	TERMINAL STRIP	
TB6	362-2002	TERMINAL STRIP	
	127-2001	INSULATOR, PILOT LIGHT ASSEMBLY	
	132-2002	BRACKET, POWER SWITCH	
	136-2005	SHIELD, PILOT LIGHT	
	168-2000	STANDOFF, HEX	x2
	168-2001	SPACER	x4
	359-2004	STANDOFF, HEX, 5-32 x 1/2, 2-56 THD	x2
	359-2012	BINDING POST	

2

CR205

C234

9

C300

8

C226

mplifier Board

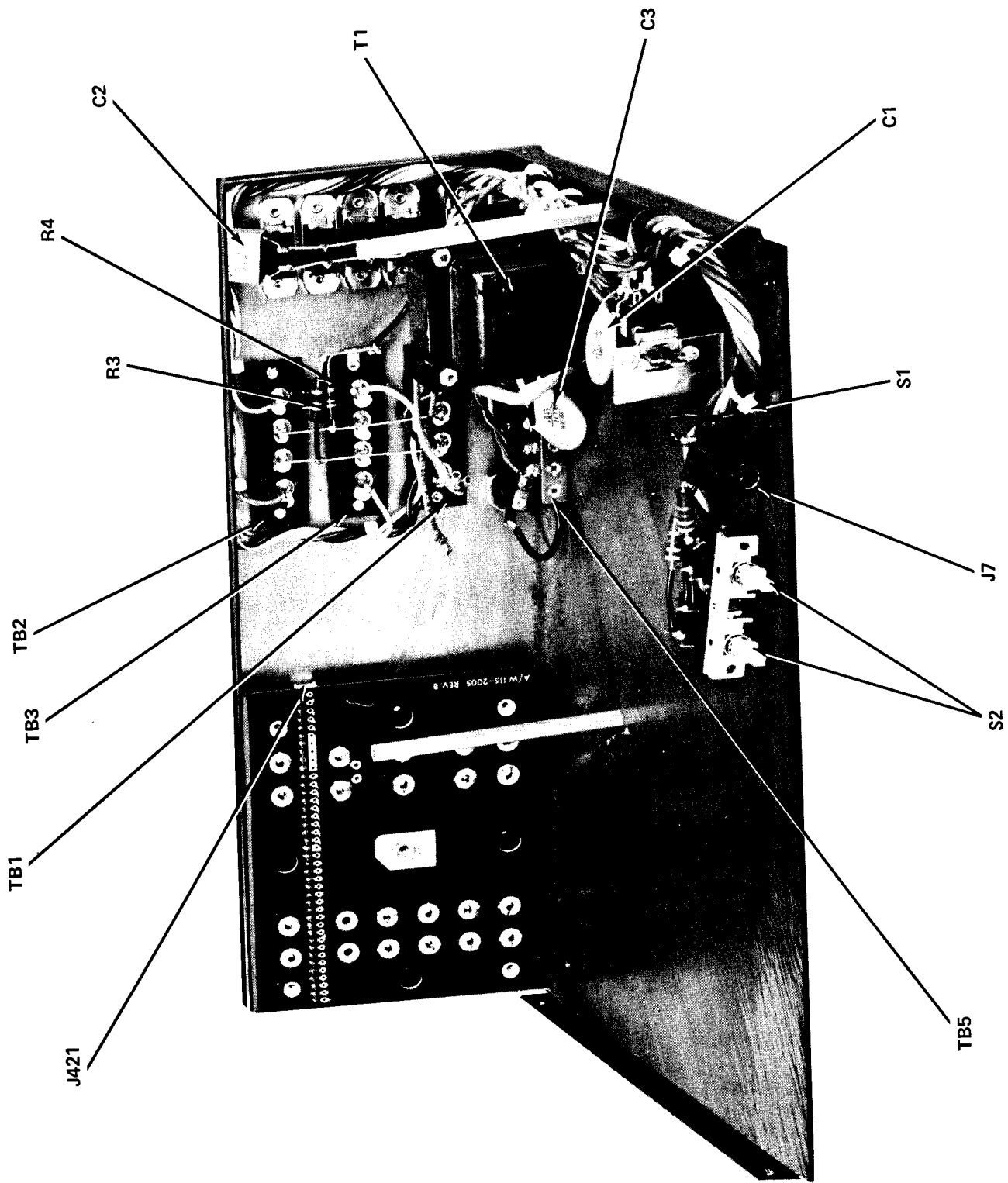

A1 Chassis

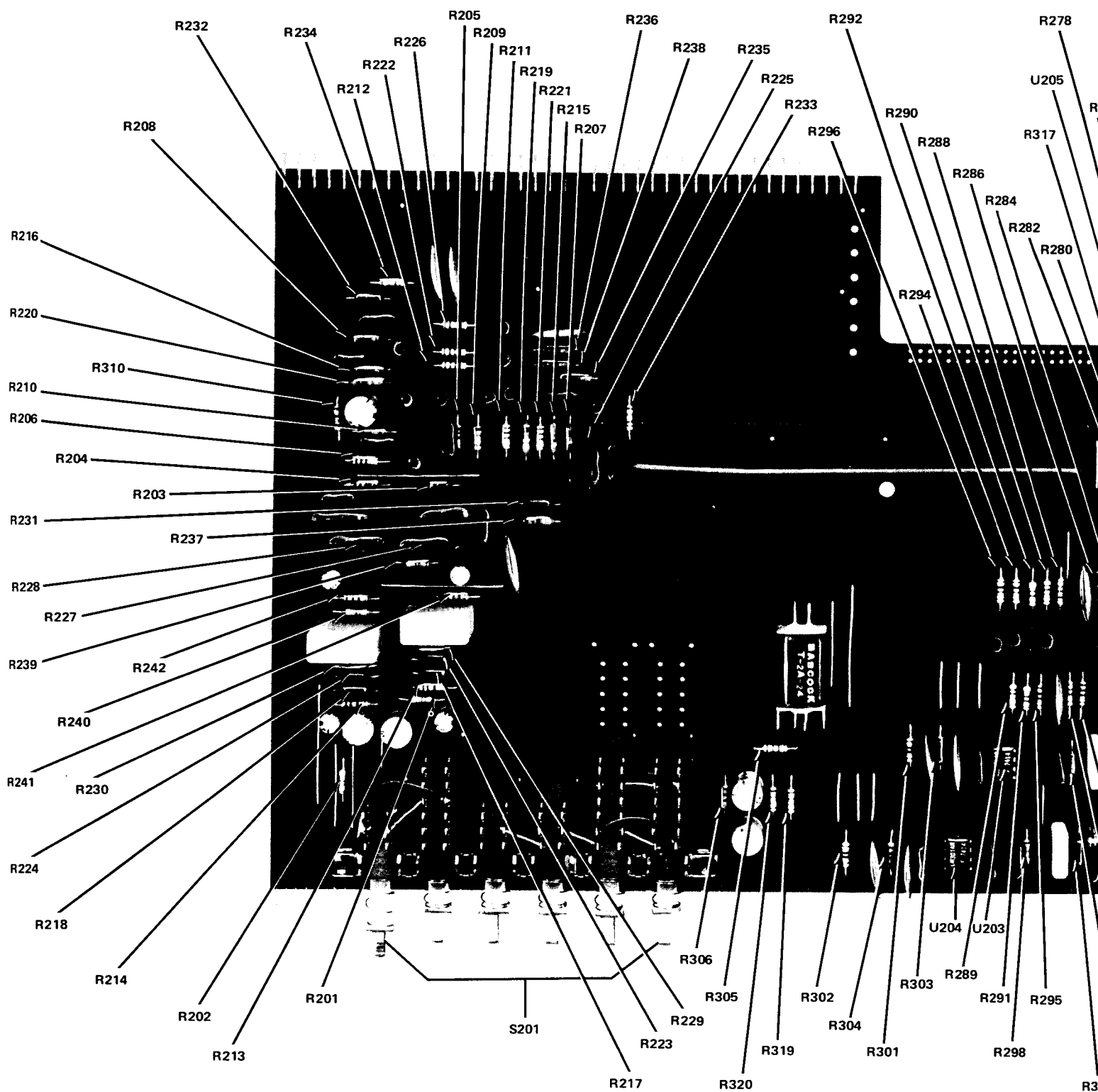

A200-300 Preamplifier Board

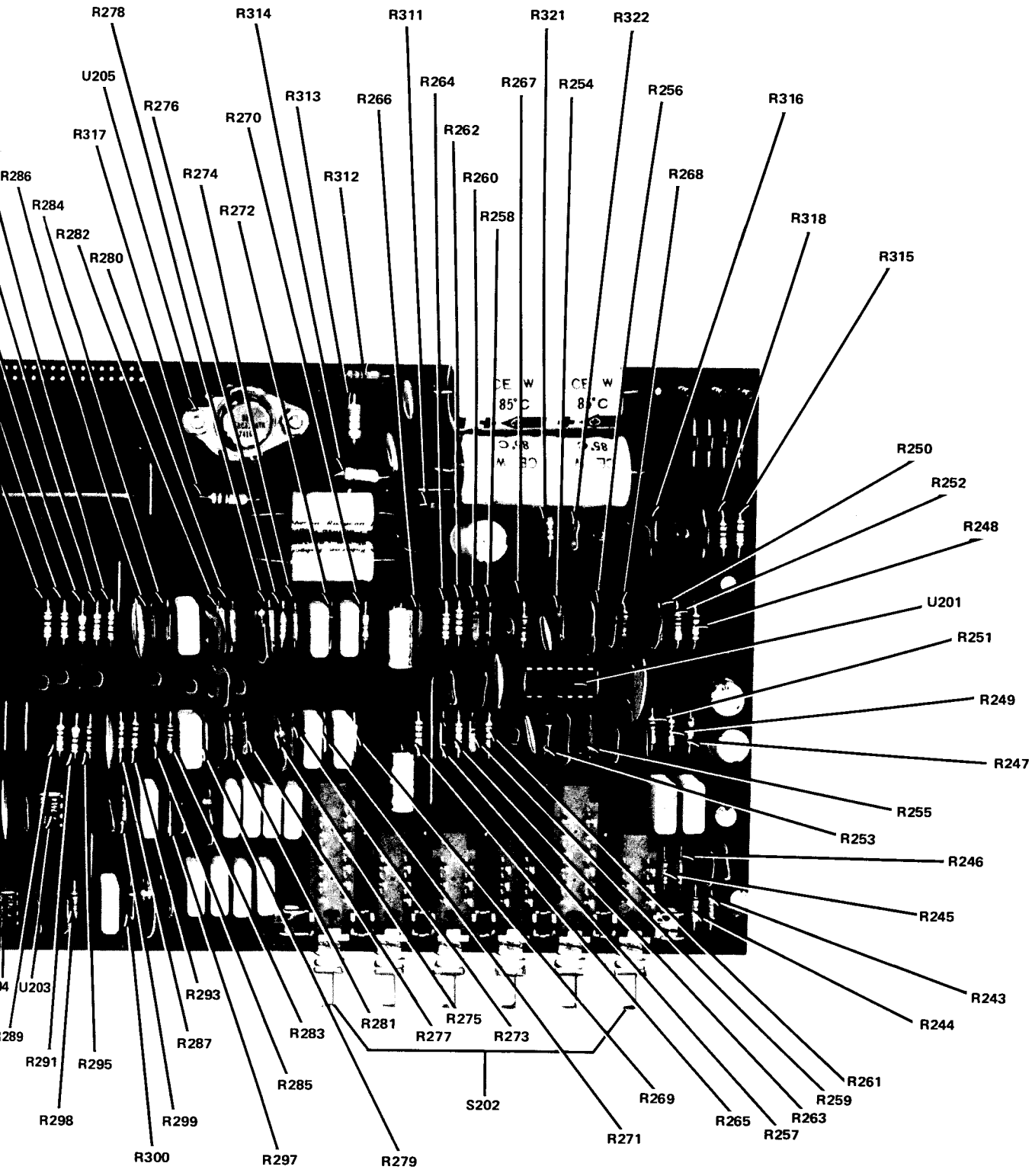

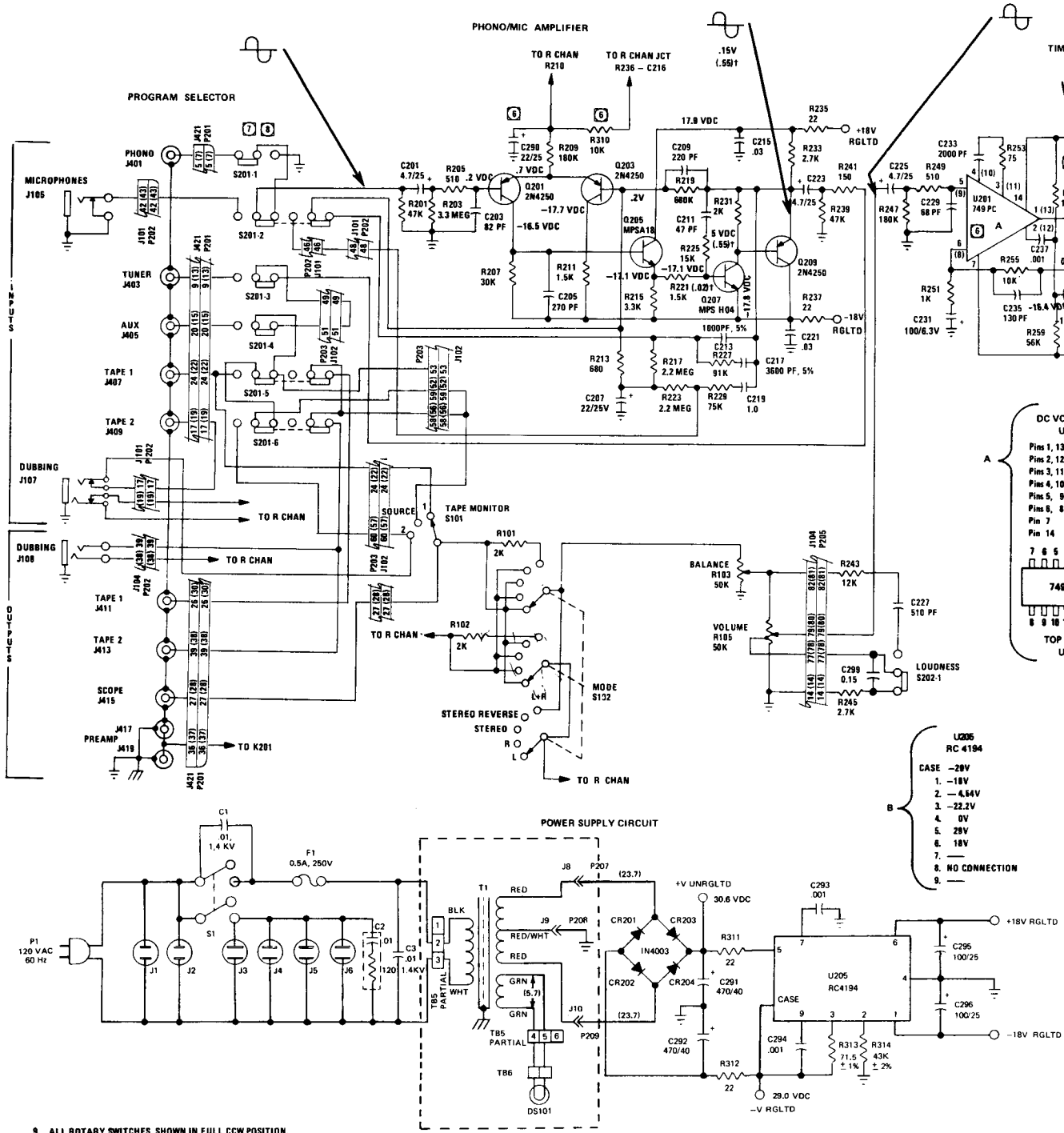

9. ALL ROTARY SWITCHES, SHOWN IN FULL CCW POSITION.
  - ④ SWITCHES S201-1 THRU S201-6 ARE INTERLOCKING.
  - ⑦ ALL SWITCHES EXCEPT PHONO ARE SHOWN IN NORMALLY OUT POSITION.
  - ⑤ COMPONENT OR CIRCUIT COMMON TO BOTH CHANNELS.
  5. LEFT CHANNEL REFERENCE DESIGNATIONS ARE ODD NUMBERS, RIGHT CHANNEL REFERENCE DESIGNATIONS ARE NEXT HIGHER EVEN NUMBERS.
  4. NUMBERS IN PARENTHESIS ARE FOR RIGHT CHANNEL.
  3. THIS SCHEMATIC SHOWS LEFT CHANNEL ONLY.
  2. CAPACITORS IN MFD, 10%. POLARIZED CAPACITORS ARE ELECTROLYTICS, (+100%, -20%).
  1. RESISTORS IN OHMS, 1/4W, 5%.
- NOTES, UNLESS SPECIFIED:

7. ( ) + INDICATES AC VOLTAGES EXPRESSED IN RMS WITH A SIGNAL APPLIED TO THE PHONO INPUT. SIGNAL GENERATOR USED: SOURCE 1.
  6. ( ) - INDICATES AN AC VOLTAGE EXPRESSED IN RMS WITH A SIGNAL APPLIED TO THE AUX INPUT. SIGNAL GENERATOR USED: SOURCE 1.
  5. ALL DC VOLTAGES MEASURED WITH NO SIGNAL APPLIED, INPUT.
  4. ALL VOLTAGES MEASURED WITH CONTROLS IN THE MID-RANGE POSITION.
  3. ALL VOLTAGES MEASURED WITH RESPECT TO CHASSIS GROUND.
  2. ALL VOLTAGES MEASURED WHILE MAINTAINING CONSTANT 120VAC.
  1. ALL INDICATED VOLTAGES ARE WITHIN ± 10% TOLERANCE.
- NOTES: VOLTAGES UNLESS SPECIFIED:

**Schematic Diagram**

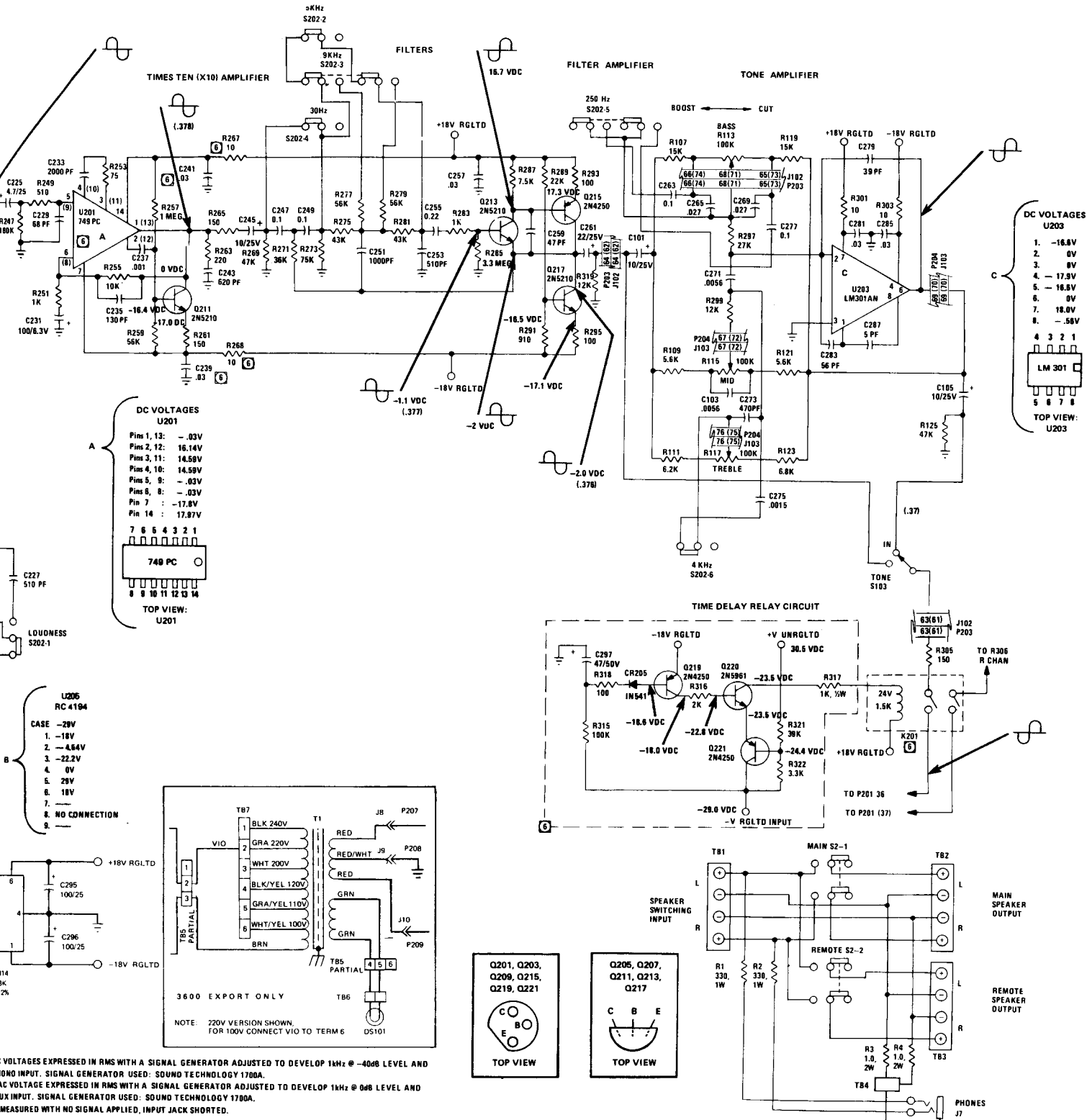

REFER DESIGN

- C247 thru
- C250
- C251
- C252
- C253
- C254
- C255
- C256
- C257
- C258

- C259
- C260
- C261
- C262

- C263
- C264
- C265
- C266
- C267
- C268
- C269
- C270
- C271
- C272
- C273
- C274
- C275
- C276
- C277
- C278
- C279
- C280
- C281
- C282
- C283
- C284
- C285
- C286
- C287
- C288
- C289
- C290

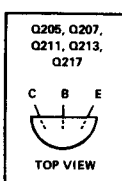
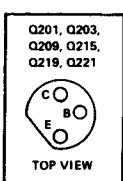
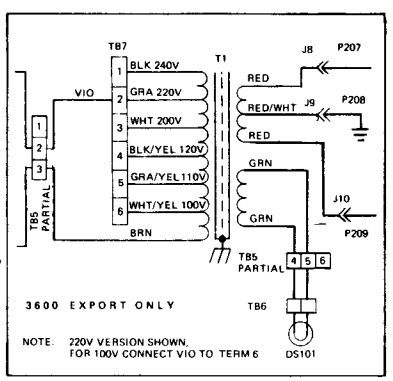
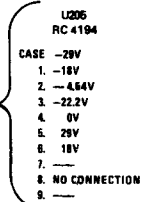
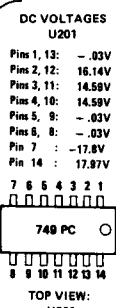
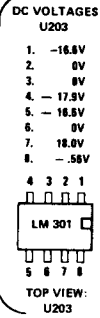

VOLTAGES EXPRESSED IN RMS WITH A SIGNAL GENERATOR ADJUSTED TO DEVELOP 1kHz @ -40dB LEVEL AND 100mV INPUT. SIGNAL GENERATOR USED: SOUND TECHNOLOGY 1780A.

DC VOLTAGE EXPRESSED IN RMS WITH A SIGNAL GENERATOR ADJUSTED TO DEVELOP 1kHz @ 0dB LEVEL AND 100mV INPUT. SIGNAL GENERATOR USED: SOUND TECHNOLOGY 1780A.

MEASURED WITH NO SIGNAL APPLIED, INPUT JACK SHORTED.

MEASURED WITH CONTROLS IN THE MID-RANGE POSITION, TONE SWITCH ON.

MEASURED WITH RESPECT TO CHASSIS GROUND.

MEASURED WHILE MAINTAINING CONSTANT 120 VOLT LINE INPUT THROUGH AN AUTOTRANSFORMER.

VOLTAGES ARE WITHIN ±10% TOLERANCE.

RESISTORS ARE AS SPECIFIED.



REFERENCE DESIGNATION	MARANTZ PART NUMBER	NOMENCLATURE
C247 thru C250	386-2002	CAPACITOR, 0.1 MFD
C251, C252, C253, C254	385-1091	CAPACITOR, 1000PF $\pm$ 5%, 100V
C255, C256	385-2002	CAPACITOR, 510PF $\pm$ 5%, 100V
C257, C258	386-2005	CAPACITOR, 0.22 MFD
C259, C260	383-1002	CAPACITOR, .03MFD $\pm$ 20%, 100V
C261, C262	385-1040	CAPACITOR, 47PF
C263, C264	381-3003	CAPACITOR, 22MFD + 100%, -20%, 25V
C265, C266	386-2002	CAPACITOR, 0.1 MFD
C267	386-2001	CAPACITOR, 0.027MFD
C268		NOT USED
C269, C270		NOT USED
C271, C272	386-2001	CAPACITOR, 0.027MFD
C273, C274	386-2000	CAPACITOR, 5600PF
C275, C276	385-1087	CAPACITOR, 470PF
C277, C278	385-1094	CAPACITOR, 1500PF
C279, C280	386-2002	CAPACITOR, 0.1MFD
C281, C282	385-1035	CAPACITOR, 39PF $\pm$ 10%, 500V
C283, C284	383-1002	CAPACITOR, .03MFD $\pm$ 20%, 100V
C285, C286	385-2001	CAPACITOR, 56PF
C287, C288	383-1002	CAPACITOR, .03MFD $\pm$ 20%, 100V
C289	385-1049	CAPACITOR, 5PF
C290	381-3003	NOT USED
		CAPACITOR, 22MFD + 100%, -20%, 25V

REFERENCE DESIGNATION	MARANTZ PART NUMBER	NOMENCLATURE
C291, C292	381-2001	CAPACITOR, 470MFD + 100%, -20%, 50V
C293, C294	383-2000	CAPACITOR, .001MFD, GMV, 300V
C295, C296	381-2000	CAPACITOR, 100MFD + 100%, -20%, 25V
C297	381-3007	CAPACITOR, 47MFD + 100%, -20%, 50V
C298		NOT USED
C299, C300	386-2004	CAPACITOR, 0.15MFD
CR201 thru CR204	460-2000	DIODE, RECTIFIER, 1N4003
CR205	460-1010	DIODE, RECTIFIER, 1N541
K201	410-2000	RELAY, REED, DPST (NO)
Q201 thru Q204	461-2001	TRANSISTOR, PNP, 2N4250
Q205, Q206	462-2000	TRANSISTOR, NPN, MPSA18
Q207, Q208	462-2018	TRANSISTOR, NPN, MPSH04
Q209, Q210	461-2001	TRANSISTOR, PNP, 2N4250
Q211 thru Q214	462-2002	TRANSISTOR, NPN, 2N5210
Q215, Q216	461-2001	TRANSISTOR, PNP, 2N4250
Q217, Q218	462-2002	TRANSISTOR, NPN, 2N5210
Q219	461-2001	TRANSISTOR, PNP, 2N4250
Q220	462-2004	TRANSISTOR, NPN, 2N5961
Q221	461-2001	TRANSISTOR, PNP, 2N4250