

marantz®

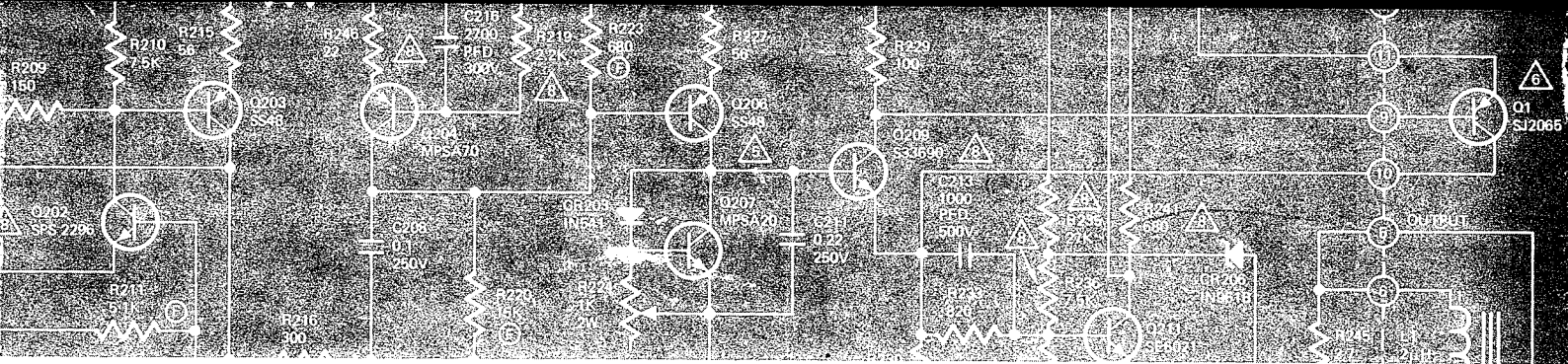

**SERVICE
MANUAL**

MODEL 500

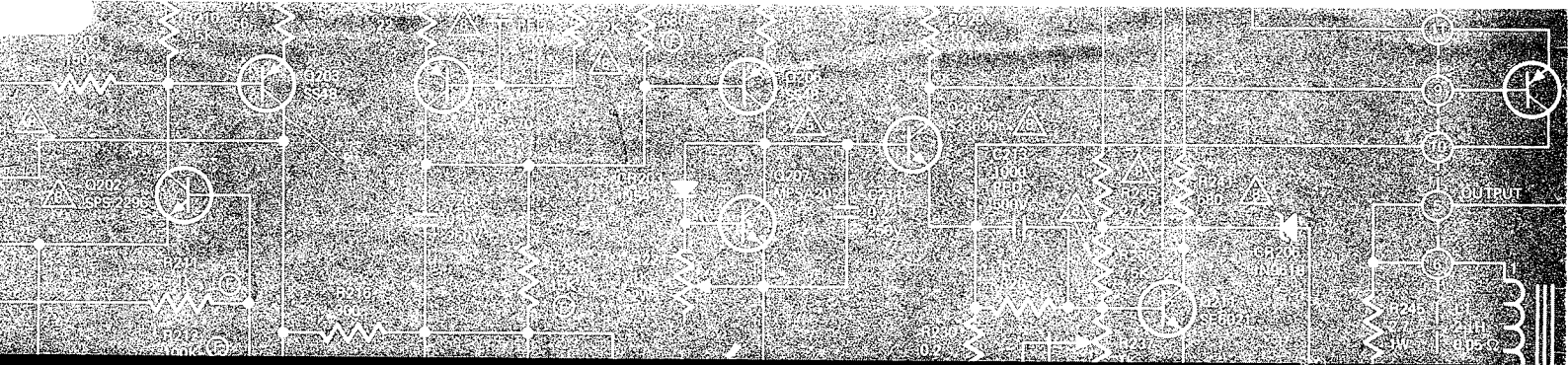

Stereo Power Amplifier

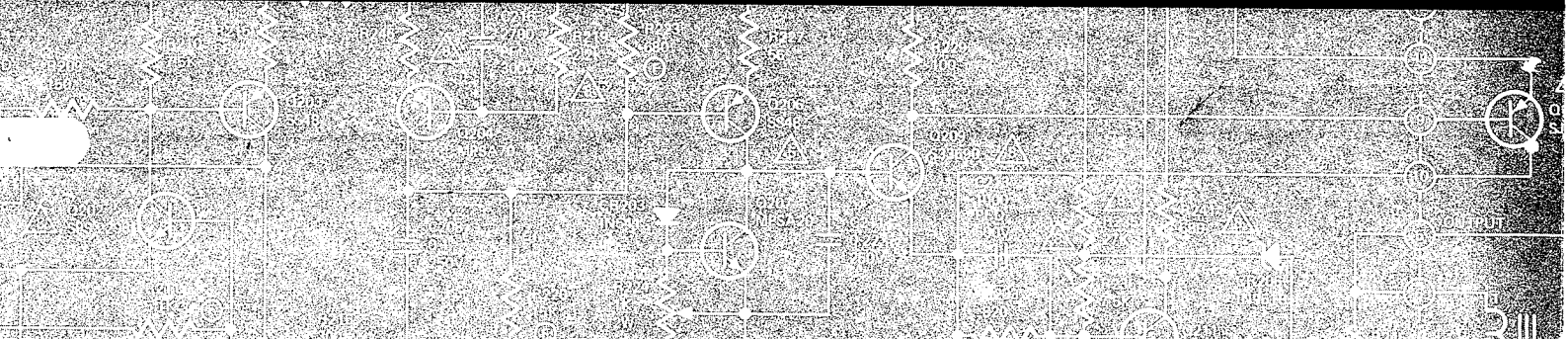

TABLE OF CONTENTS

Section	Page	Service Notes	12
Introduction	1	Disassembly/Re-assembly Instructions	12
Caution	1	Top Cover	12
Technical Specifications	2	Bottom Cover	13
Recommended Test Equipment	5	Front Panel Assembly	13
Performance Verification	7	Pilot Lamp	13
Test Procedure	7	Meter Board Assembly	13
Test Equipment	7	Meter	13
Preliminary Procedures	7	Front Panel	13
Bias Test	7	Driver Board Assembly	14
Relay Operation Test	8	Rear Panel Assembly	14
DC Balance Test	8	Ch. A Heatsink Component Assembly	14
Total Hum and Noise Test	8	Heatsink-Mounted Transistors	14
Maximum Power Output Test	8	Ch. A Power Amplifier Board Assembly	15
Harmonic Distortion Test	8	Heatsink Fan	15
Frequency Response Test	8	Ch. B Heatsink Component Assembly	16
Gain Test	8	Ch. B Power Amplifier Board Assembly	16
Gain Differential Test	9	Rectifier/Relay Board Assembly	16
Channel Separation Test	9	Power Supply Assembly	16
Meter Calibration Test	9	Voltage Conversion Instructions	16
Adjustment Procedure	9	100 VAC Conversion	16
Test Equipment	9	220 VAC Conversion	16
Preliminary Procedures	9	Parts List ("Loose" Parts)	18
Unit Disassembly	9	Parts List - Front Panel Assembly	18
Bias Adjustment	9	Parts List - Power Supply Assembly	19
DC Balance Adjustment	10	Parts List - Heatsink Component Assembly	19
SOA Limit Adjustment	10	Parts List - Driver Board Assembly	22
Meter Calibration	12	Parts List - Power Amplifier Board Assembly	23 & 24
		Parts List - Meter Board Assembly	25
		Parts List - Rectifier/Relay Board Assembly	25

marantz® SERVICE BULLETIN	model number 500	bulletin number M - 500 - 1
	for serial numbers ALL	
	subject POWER TRANSISTOR REPLACEMENTS	
	engineering approval <i>J. E. Branco</i>	date 3-26-75

When replacing transistors in the Marantz Model 500, it is imperative that the Beta Range Chart be referred to before replacements are ordered. To determine the proper beta range, note the color code on the transistor, then obtain the corresponding dash number from the chart. For example:

Replacement part number 462-1056-100 is to replace a RED coded 2N3440.

Replacement part number 462-1056-400 is to replace a GREEN coded 2N3440.

<u>REF DES.</u>	<u>VENDOR PART NO.</u>	<u>MARANTZ PART NO.</u>	<u>DASH NO.</u>	<u>BETA RANGE</u>	<u>COLOR CODE</u>
Q110 Q111 Q118	2N3440	462-1056-	-100 -200 -300 -400	40 - 49 50 - 74 75 - 99 100 - 160	RED ORANGE YELLOW GREEN
Q112 Q113 Q117	2N5415	461-1049-	-100 -200 -300 -400	30 - 49 50 - 74 75 - 99 100 - 150	RED ORANGE YELLOW GREEN
Q301	SJ2504	462-1025-	-100 -200 -300	40 - 75 76 - 100 101 & UP	RED YELLOW GREEN
Q302	SJ2503	461-1018-	-100 -200 -300	50 - 100 101 - 200 201 & UP	ORANGE GREEN GRAY
Q303 Q304 Q305 Q306	SJ2500 <i>use</i> <i>2SD555</i>	462-1023-	-100 -200 -300 -400	30 - 49 50 - 69 70 - 99 100 & UP	RED ORANGE YELLOW GREEN
Q307	SJ2505	461-1019-	-100 -200 -300	40 - 75 76 - 100 101 & UP	RED YELLOW GREEN

MARANTZ SERVICE BULLETIN NO. M-500-1

March 26, 1975

Page 2 of 2

<u>REF DES.</u>	<u>VENDOR PART NO.</u>	<u>MARANTZ PART NO.</u>	<u>DASH NO.</u>	<u>BETA RANGE</u>	<u>COLOR CODE</u>
Q308	SJ2502	462-1024-	-100 -200 -300	50 - 100 101 - 200 201 & UP	ORANGE GREEN GRAY
Q309 Q310 Q311 Q312	SJ2501 <i>use 25B600</i>	461-1017-	-100 -200 -300 -400	30 - 49 50 - 69 70 - 99 100 & UP	RED ORANGE YELLOW GREEN

NOTE: The beta color code of the SJ2500 transistor group (Q303 through Q306) can differ from the SJ2501 transistor group (Q309 through Q312) by one color difference on either heatsink assembly. Example:

All SJ2500 transistors on Channel A heatsink are ORANGE. The SJ2501 transistors on the opposite end of Channel A heatsink can be coded all RED or all YELLOW if an ORANGE beta color code replacement is not available.

This substitution applies to the SJ2500 and SJ2501 groups only. All other devices should be matched per notes in the Service Manual. THIS SUBSTITUTION SHOULD BE DONE ONLY IF THE PROPER BETA RANGE IS NOT OBTAINABLE.

After replacing output transistor always recheck bias adjustment and harmonic distortion per instructions on page 8 of the service manual.

Incorporate this change into the Service Manual as soon as possible to ensure proper service information.



Albert Almeida, Manager
Technical Services

 SERVICE BULLETIN <small>SS-MAR0234</small>	model number 500	bulletin number M-500-2
	for serial numbers ALL	
	subject POWER OUTPUT TRANSISTOR REPLACEMENT	
	engineering approval <i>[Signature]</i>	date 7-15-76

Effective immediately, all field replacements of the power output transistors in the Marantz Model 500 should be replaced with the new improved devices as follows:

<u>Designation</u>	<u>Old Part Number (Motorola)</u>	<u>New Part Number (NEC)</u>
Q303 - Q306	462-1023-XXX	462-2025-000
Q309 - Q312	461-1017-XXX	461-2014-000

When the new NEC devices are used to replace the Motorola devices, all output transistors in that channel must be replaced. For instance, if only 3 devices of the 8 total in a channel fail, all 8 output transistors must be replaced. There must be no mixture of Motorola devices with NEC devices in any given channel. This is necessary since the saturation characteristics of the two transistor types are different.

After replacing output transistors always recheck bias adjustment and harmonic distortion per instructions on pages 7 through 9 of the Service Manual.

 Albert Almeida, Manager
 Technical Services

LIST OF ILLUSTRATIONS

Figure		Page
1	Model 500 Front View	1
2	Model 500 Rear View	1
3	Functional Block Diagram	3 & 4
4	AC Power Control Box Schematic	6
5	Amplifier Output Load Box Schematic	6
6	Test Equipment Set-Up	7
7	Oscilloscope Connection for SOA Limit Adjustment	11
8	SOA Limit Oscilloscope Display	11
9	Model 500 Interior View - Top	17
10	Model 500 Interior View - Bottom	17
11	Front Panel Assembly - Rear View	18
12	Power Supply Assembly - Front View	19
13	Heatsink Component Assembly	19
14	Driver Board Assembly	21
15	Power Amplifier Board Assembly	23 & 24
16	Meter Board Assembly	25
17	Rectifier/Relay Board Assembly	26
18	Model 500 Schematic	27 & 28

Table

1	Recommended Test Equipment	5
---	----------------------------	---

MODEL 500



Figure 1. Model 500 Front View

INTRODUCTION

This service manual was prepared for and is intended for use only by factory authorized warranty repair stations and other equally qualified and equipped facilities. The service information contained herein is applicable to the Model 500 Stereo Power Amplifier, manufactured by the Marantz Company, a subsidiary of Superscope Incorporated, Sun Valley.

Performance evaluation and service of the Model 500 should be undertaken only by the experienced technician, one knowledgeable in solid-state amplifier operation and use of the test equipment. All instructions should be read carefully and understood fully before proceeding with any service. To better understand the functions of this amplifier, consult the Model 500 Handbook of Instructions (P/N 199-1055-000) which provides a functional and brief technical description of the unit.

CAUTION

1. The full line voltage exists at the terminal blocks mounted on the Heatsink Assembly & Power Supply Assembly. Care should be exercised to ensure that these terminals are not accidentally contacted causing harm to the technician and/or the equipment.
2. Do not discharge any capacitors in the Model 500 with a dead short (i.e., a screw driver blade). The filter capacitors are capable of storing a sizeable charge and the current delivered through a short-circuit may be sufficient to vaporize the screw driver causing harm to the technician or the equipment. Always use a 10-ohm 1 watt resistor for this purpose.
3. All adjustments should be made using screw drivers with insulated blades and handles. Otherwise, shorting of adjacent components may occur.
4. Never directly connect the loudspeaker terminals of one channel in parallel with those of any other, as severe damage to the output devices will result.

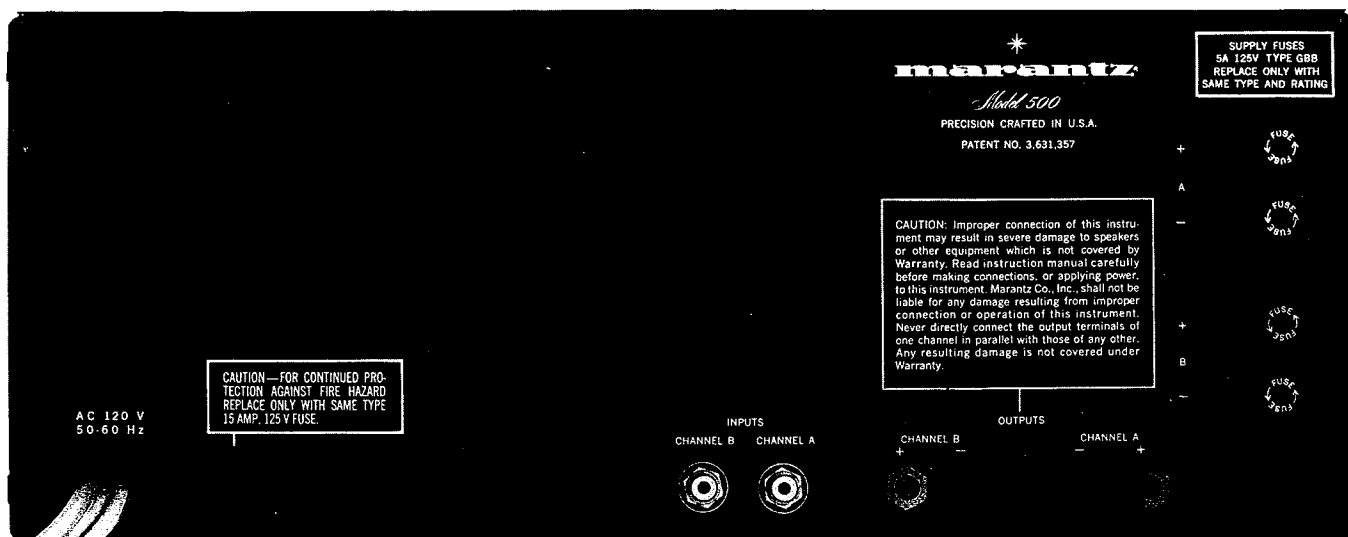

Figure 2. Model 500 Rear View

TECHNICAL SPECIFICATIONS

POWER AT CLIPPING (250/500 RANGE)

250 Watts RMS per channel, both channels driven into 8-ohm loads, 20 Hz to 20 kHz. Typically greater than 300 Watts.

TOTAL HARMONIC DISTORTION

Less than 0.05% at rated power output from 20 Hz to 20 kHz with both channels driven.

INTERMODULATION DISTORTION

Less than 0.05% at rated power output with both channels driven (S.M.P.T.E.).

CHANNEL SEPARATION

Greater than 60 dB, 20 Hz to 20 kHz.

FREQUENCY RESPONSE

20 Hz to 20 kHz at rated power output - ± 0.1 dB.

POWER BANDWIDTH

5 Hz to 35 kHz.
5 Hz to 45 kHz @ 0.1% THD

DAMPING FACTOR

Greater than 400

SENSITIVITY

2.25 Volts for 250 Watts into 8-ohm load with Gain Controls fully clockwise.

HUM AND NOISE

Better than 106 dB below 250 Watts. (8-ohm load)

INPUT IMPEDANCE

33K ohms with Gain Controls fully clockwise.

SQUARE WAVE RESPONSE

Tilt: Less than 20% at 20 Hz.
Undershoot: None
Overshoot: None
Rise Time: Less than 2.5 microseconds.
Slewing Rate: Faster than 11 Volts per microsecond.

OPERATING (PRIMARY) POWER REQUIREMENTS

Nominal Voltage	Range	Rated Power*	Frequency	Fuse
100 VAC	90 to 110 VAC	300 Watts	50 to 60 Hz	15A
120 VAC	108 to 132 VAC	300 Watts	50 to 60 Hz	15A
220 VAC	198 to 242 VAC	300 Watts	50 to 60 Hz	10A

*The rated line power is representative of the power requirements at 10% of full audio output into an 8-ohm load.

PHASE SHIFT

Leading 9° at 20 Hz.
Lagging 9° at 20 kHz.

METER MOVEMENT

Precision moving coil, jewel bearing meter movement.

TURN-ON

5 to 10 seconds delay prevents transient surges at turn-on from reaching output terminals. Input current limiting circuit reduces line inrush current to 50 amperes.

POWER SUPPLY

2.2 Kilowatt transformer; high current, silicon bridge rectifiers, and computer grade energy storage devices capable of energy storage exceeding 280 joules.

VOLTAGE CONVERSION

Special tapped primary allows easy conversion to 100 VAC or 220 VAC operation.

PROTECTION

Built-in circuits, together with line and supply fuses, provide protection against overload.

CONTROLS

Independent front panel Gain Controls and Power Level selector switch.

FRONT PANEL

Standard 19" x 7", with RETMA mounting hole spacing.

DIMENSIONS

16-3/4" wide, 6-3/4" high, 17-1/8" deep from panel mounting surface.

FINISH

Brushed gold anodize and black enamel.

WEIGHT

Net: 83 Lbs.
Packed for Shipment: 88 Lbs.

MODEL 500

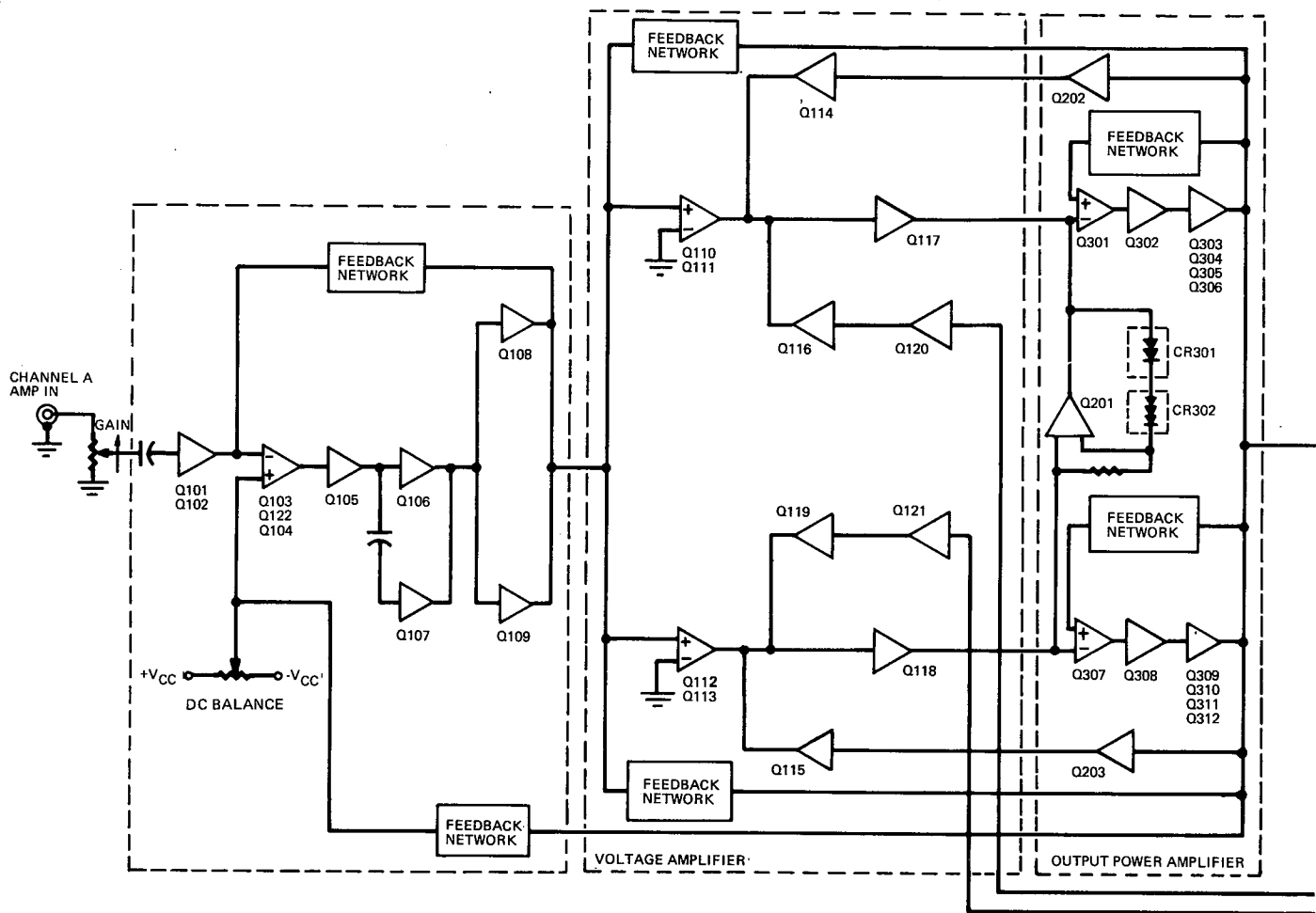

3 Figure 3. Functional Block Diagram

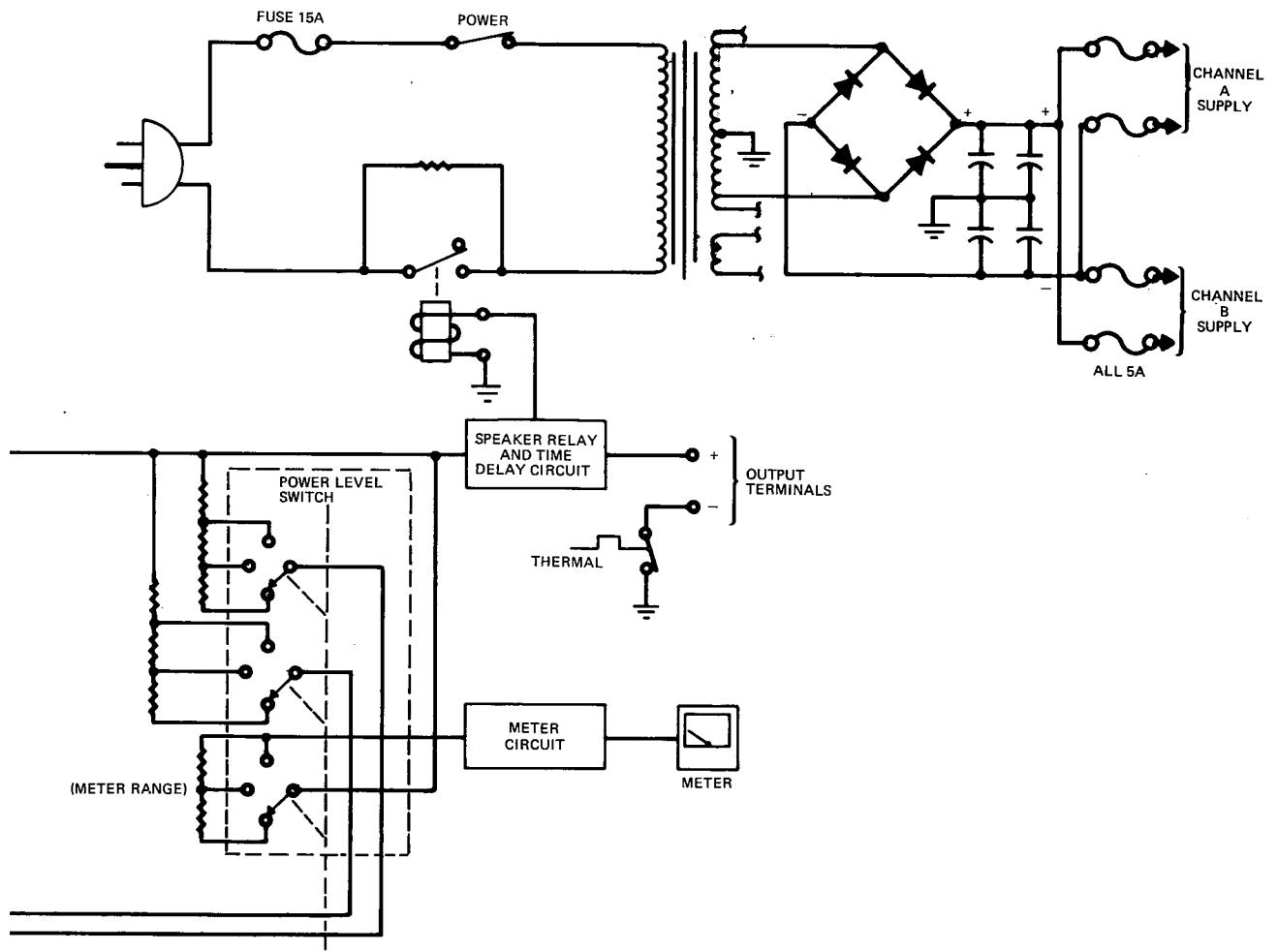

Figure 3. Functional Block Diagram (Cont.)

RECOMMENDED TEST EQUIPMENT

The test equipment listed below is recommended for servicing the Model 500 Stereo Power Amplifier. The Performance Verification and Adjustment Procedure sections of this manual are based on the use of these items or their equivalent.

TABLE 1

Item	Manufacturer and Model Number	Use
AC Wattmeter	Simpson Model 390	Monitor primary power consumption of amplifier
Line Voltmeter (0 - 150 VAC)	Commercial Grade	Monitor primary line voltage to amplifier
Variable Autotransformer (0 - 140 VAC, 22 Amps)	Powerstat Model 136B	Controls level of primary power to amplifier
Above items to be assembled per Figure 4 as AC Power Control Box		
Output Load Resistor (4 $\Omega \pm 0.5\%$, 250W) 6 Required	Commercial Grade	Provides load for amplifier output termination
Output Load Capacitor (0.5 μfd , 300V) 2 Required	Mylar	Provides capacitive load for instability tests
Output Load Capacitor (11 μfd , 300V) 2 Required	Mylar	Provides phase shift for SOA Limit Adjustment
Above items to be assembled per Figure 5 as Amplifier Output Load Box		
Distortion Analyzer	Hewlett Packard Model 331A or 333A	Measures distortion and voltage of amplifier output
Audio Oscillator	Weston Model CV0-100P (Note: Less than 0.02% residual distortion is required)	Sinewave Signal Source
Oscilloscope	Tektronix Model 503 or Data Model 555	Waveform analysis
VTVM	RCA Senior Volt-Ohmyst Model WV-98C	Voltage and resistance measurements
Resistance Substitution Box	Commercial grade with 5% RETMA steps in resistance from 270 Ω to 3.3K	Provides selectable resistance for bias adjustment
Oscilloscope	Tektronix Model 561 with two Model 3A7 Differential Comparators	Waveform analysis during SOA adjustment
Above items to be assembled per Figure 6 or as directed in Test or Adjustment Procedures		
Bleeder Resistor (10 Ω , 1W)	Commercial Grade	Discharges filter capacitors

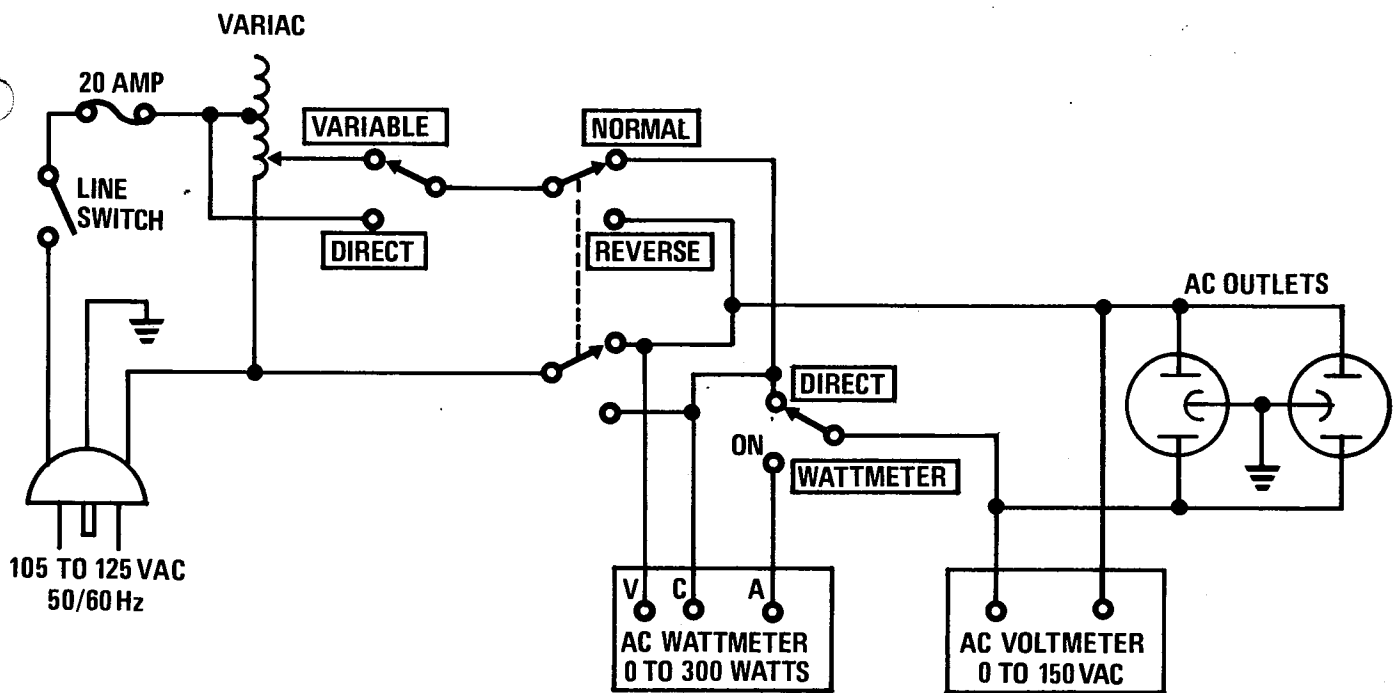

Figure 4. AC Power Control Box Schematic

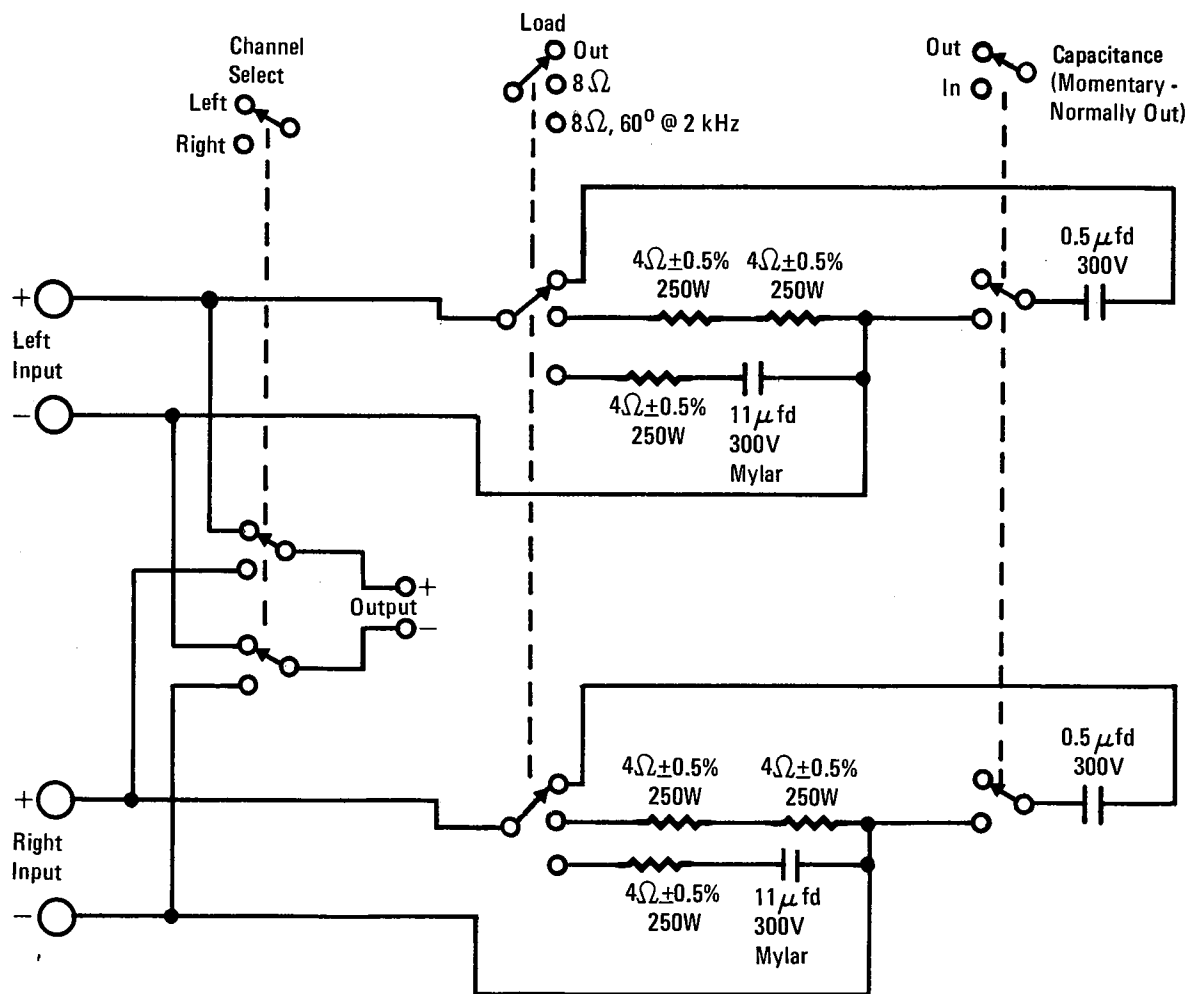

Figure 5. Amplifier Output Load Box Schematic

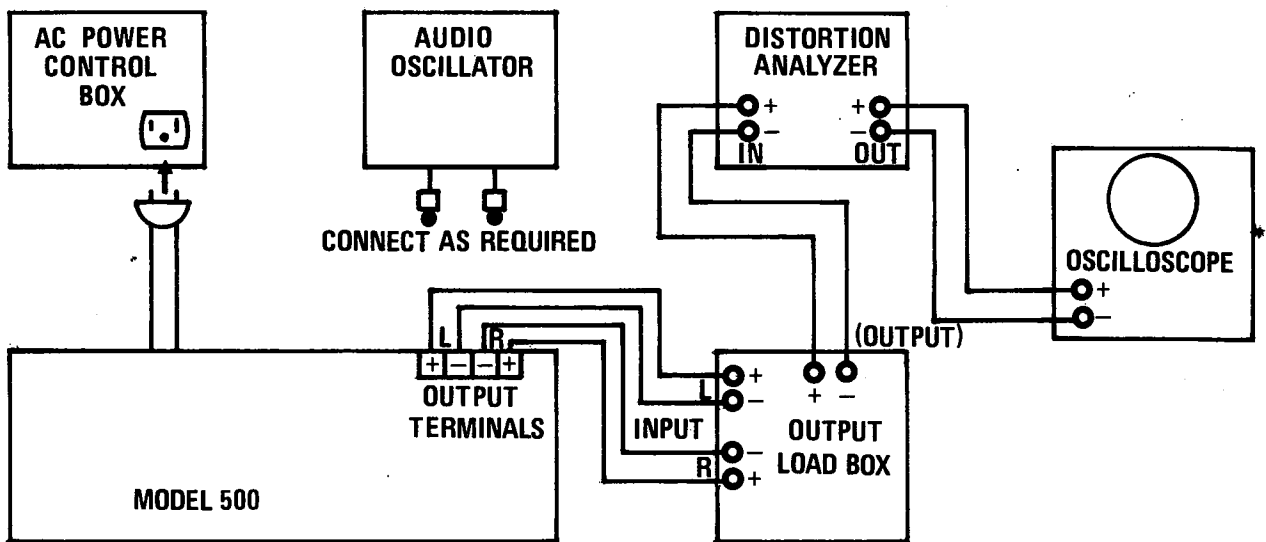

Figure 6. Test Equipment Set-Up

PERFORMANCE VERIFICATION

Test Procedure

All tests outlined below should be performed after any repair or adjustment. The tests described in paragraphs C through L may also be used as a method of isolating the defect prior to service. Should the results of the tests be other than as specified, refer to the Adjustment Procedure section of this manual. Unless otherwise specified, all tests are to be performed on both audio channels, with the results specified applying equally to each channel.

A. Test Equipment

Refer to Table 1 for list of recommended test equipment.

B. Preliminary Procedures

1. All tests are performed with the unit under test and the test equipment connected as shown in Figure 6. Only the rear panel input/output connection facilities of the Model 500 will be used for these tests. Except for the IDLING POWER test, all tests are conducted with 120 VAC line voltage applied to the unit. Unless otherwise specified in the procedure, the test equipment controls will be set in the following position:

AC Power Control Box

Line Switch ON
 Wattmeter Switch. DIRECT
 Variac 120 VAC LINE

Amplifier Output Load Box

Channel Select . . . SET FOR CHANNEL UNDER TEST
 Capacitance Switch OUT

During all the tests listed below the controls of the Model 500 under test will be set as follows:

Gain (both channels). MAX
 Power Level (both channels). . 250/500
 Power ON

2. Connections, between the output terminals of the Model 500 and the Output Load Box, must have negligible resistance with respect to the resistance of the load itself. Appreciable resistance adds to the total load, resulting in inaccurate measurement of output power.

C. Bias Test

1. With the Line Switch OFF, the Variac set to 0 (fully CCW) and the Wattmeter Switch to WATTMETER, plug the unit line cord into the AC Power Control Box.
2. On the Amplifier Output Load Box, set the Load Switch to OUT.
3. Turn the Line Switch ON and slowly advance the Variac while observing the Voltmeter and Wattmeter on the Power Control Box. When the line voltage reaches 120 VAC the Wattmeter should indicate between 120 and 150 watts.
4. If the Wattmeter reading is greater than 160 watts for any static Variac position, do not further increase the AC voltage.

Turn off the unit and refer to Bias Adjustment in the Adjustment Procedure section of this manual.

D. Relay Operation

1. Set Line Switch to OFF. Wait approximately 30 seconds.
2. Switch line ON. Time the delay between power turn-on and the moment that the relays energize (signaled by two audible clicks within the amplifier). The elapsed time should be between 2 and 10 seconds.
3. Connect the Audio Oscillator to the input jacks of both channels. Adjust frequency to 5 Hz and set level to minimum.
4. Slowly increase the Oscillator level until the relays de-energize carefully observing the highest voltage reached prior to relay cut-off. The output voltage should be between 25 and 33 volts.

E. DC Balance

1. With the Load Switch on the Amplifier Output Load Box set to OUT, connect a VTVM (set in the DC MODE) to the output terminals of the Load Box.
2. Allow the unit to reach operating temperature (approximately 3 minute warm-up).
3. Check each channel for a DC voltage of $0V \pm 50$ mV.

CAUTION: THE OUTPUT VOLTAGE MAY BE AS HIGH AS $\pm 82V$ IN A UNIT WITH MULTIPLE OPERATING DEFECTS.

F. Total Hum and Noise Test

1. Set the Load Switch on the Amplifier Output Load Box to 8 ohm. With the amplifier gain controls set to minimum (fully CCW), the output voltage through a 20 Hz - 20 kHz band pass filter should be 0.25 mV or less for each channel.
2. If the output voltage is greater than 0.25 mV on either channel, or both channels, refer to the Trouble Analysis section.

G. Maximum Power Output

1. Connect the Audio Oscillator to the input jacks of both channels, with frequency set to 2 kHz and the level set to minimum. Switch in the 8 ohm load.

2. Set the Audio Oscillator level for 44.7 volts output. Verify that neither channel is clipping.
3. Change Audio Oscillator frequency to 20 Hz and re-adjust level (if necessary) for 44.7V output. Verify lack of clipping on both channels.
4. Adjust Oscillator frequency to 20 kHz and re-set level (if required) for 44.7V output. Neither channel should be clipping.

H. Harmonic Distortion Test

1. Connect the Audio Oscillator to both channels and set the frequency to 20 Hz. Switch in the 8 ohm load.
2. Set the Oscillator level for 44.7 volts output. The distortion should measure less than 0.05%.
3. Change the Oscillator frequency to 20 kHz and re-adjust the level (if necessary) for 44.7 volts output. The measured distortion should be less than 0.05%. If the unit fails to meet this specification and the output waveform, when viewed on the scope, indicates the presence of spikes, refer to Bias Adjustment in the Adjustment Procedure section of this manual.
4. Switch the Output Load Capacitance to IN. Verify the lack of parasitic oscillation. The distortion should be less than 0.1%.

J. Frequency Response Test

1. Connect the Audio Oscillator to both channel input jacks. Switch in the 8 ohm load. Adjust oscillator frequency to 2 kHz and set level for 44.7V output.
2. Sweep Oscillator frequency from 20 Hz to 20 kHz. The output voltage of each channel should remain within the range of 44.25 and 44.7 volts.

K. Gain Test

1. Apply a 1 kHz signal to the input jack of Channel A. With an 8 ohm load, adjust the oscillator level for any convenient output voltage.
2. Measure the input voltage level. The difference between the input and output signal levels should be 26.3 dB ± 0.25 dB.

L. Gain Differential Test

1. Apply an identical 1 kHz signal to the inputs of each channel. Set the oscillator level for any convenient output voltage into the 8 ohm load.
2. Verify that both channels have the same output voltage with 0.2 dB.

M. Channel Separation Test

1. Apply the output of the Audio Oscillator to the Channel A input jack. Set the Channel B gain Control to minimum.
2. With the Load Box set for an 8 ohm load, set the Oscillator frequency to 20 kHz and the Oscillator level for a convenient output voltage.
3. Measure the output voltage of Channel B and verify that it is 55 dB or more below the level of the driven channel.
4. Repeat test for Channel A output with Channel B driven.

N. Meter Calibration Test

1. Verify zero set of both meters; adjust if required.
2. Apply a 2 kHz signal to the Channel A input jack. Switch in the 8 ohm load.
3. Verify that the Channel A meter reading is within 0.5 dB of the value indicated below.

<u>OUTPUT VOLTS</u>	<u>METER READING</u>
3.16	- 20 dB
22.36	- 3 dB
31.6	0 dB
44.7	+ 3 dB

4. Adjust the oscillator frequency to 10 kHz, adjust the level for an output voltage of 31.6V into the 8 ohm load. The meter should indicate 0 dB \pm 0.5 dB.
5. Adjust the oscillator frequency to 20 kHz. Re-adjust the level, if necessary, for an output of 31.6V. Verify that the meter indicates 0 dB \pm 0.5 dB.

If the meter readings are other than as specified above, refer to the Meter Calibration procedure outlined in the Adjustment Procedure section of this manual.

ADJUSTMENT PROCEDURE

This section outlines the recommended methods used to perform those adjustments which are to be made only by the service technician and then only after the appropriate test outlined in the Performance Verification section has indicated a need for such adjustment. It should be noted that these adjustments will normally be required only after replacement of parts and very rarely as a result of component "aging."

A. Test Equipment

Refer to Table 1 for recommended test equipment.

B. Preliminary Procedures

The preliminary procedures outlined in the Performance Verification section of this manual are applicable in their entirety.

C. Unit Disassembly

The disassembly procedure for the Model 500 is described in the Service Notes section of this manual. The degree of disassembly required for each adjustment is specified in each adjustment procedure.

D. Bias Adjustment

1. Disassemble the unit to the stage where the Power Amplifier board, of the audio channel that requires adjustment, is accessible (see the Service Notes section of this manual for disassembly instructions). The errant channel of a unit that has a high power consumption may be determined by measuring the current through the supply fuses (F2 through F5); the adjustment being required on that channel drawing significantly more current.
2. With the AC power disconnected from the unit, remove R202 from between terminals 24 and 25 of the Power Amplifier Board. (Refer to Figure 15 for location).

CAUTION: Never allow a short circuit to exist between these terminals as catastrophic failures in the output circuit may result.

3. Insert a resistance substitution box (R-box) between terminals 24 and 25. Select a value of 3.3K ohms or higher.

4. Apply 120 VAC 60 Hz power to the Model 500. Apply the output of the Audio Oscillator to the appropriate input jack. Set the frequency to 20 kHz and the level for a 4.5 volt output into the 8 ohm load.
5. While observing the output waveform on the scope, adjust the R-box for successively lower values of resistance until the large peaks are no longer distinguishable from the residual distortion.
6. Disconnect the Audio Oscillator from the input and disconnect the 8 ohm load. Check the line power consumption of the unit with the R-box in and out of the circuit. With the R-box in the circuit the power consumption should not increase more than 15 watts per channel. If the increase in power consumption is greater than 15 watts, adjust the R-box for a higher value of resistance which limits the power consumption increase to 15 watts or less.
7. Remove the AC power from the Model 500. Remove the R-box and substitute in its place a 1/2 watt carbon film resistor having a resistance value as close as possible to that selected by the R-box.
8. Re-assemble the Model 500.

E. DC Balance Adjustment

1. Remove the top cover from the unit (refer to the Service Notes section for disassembly instructions).
2. With the AC power disconnected from the unit, disconnect R131 from terminal E1 and reconnect it to terminal TP10 (refer to Figure 14 for location).
3. Apply power to the Model 500 and allow the unit to reach a stabilized operating temperature (about 3 minutes warm up).
4. Using a dc voltmeter with a floating ground, measure and note the voltage across R132, R135, R141, and R145 (the location of these components is indicated in Figure 14) of the audio channel requiring adjustment.
5. With the Gain control reduced to minimum, monitor the output into the 8 ohm load. Alternately adjust R136 and R139 (refer to Figure 14) until the following two conditions are met:

- (A) The measured voltage across R132, R135, R141, and R145 are nearly equal, and
- (B) the output voltage is within 100 mV of being zero. (A nearly ideal adjustment will be evidenced by an equal voltage across R135 and R145 and an equal voltage across R132 and R141, with a very small difference in voltage between the two pairs).

NOTE: If the need for re-adjustment of the dc balance is due to the replacement of R137 or R140, a proper dc balance may not be achieved if the actual values of R137 and R140 are at the opposite extremes of the tolerance range.

6. With the AC power removed from the unit, reconnect R131 to Terminal E1 (refer to step 2). Restore power to the Model 500 and again allow it to reach a stabilized operating temperature.
7. Adjust R108 (refer to Figure 14) for an output voltage across the 8 ohm load of 0 volts \pm 50 mV.
8. Replace the top cover.

F. S.O.A. (Safe Operating Area) Limit Adjustment

This adjustment will normally only need to be made after replacing Q114 or Q115 on the Driver Board Assembly or, CR201, CR202, Q202, Q203, R209, or R213 on the Power Amplifier Board. The procedure to be followed is:

1. Calibrate the oscilloscope for 20 VDC/CM horizontal deflection and 0.1 VDC/CM vertical deflection.
2. Disassemble the unit to the stage where the Power Amplifier board, of the audio channel that requires adjustment, is accessible. For access to the Channel A Power Amplifier board, it will be necessary to free the rear panel from the unit. However, by using extra long hook type probes, connections to the appropriate circuit points of the Channel B Power Amplifier board may be made without disassembling the unit beyond the removal of the top cover. See the Service Notes section of this manual for the disassembly procedure.

Teletronix Model 561 Oscilloscope

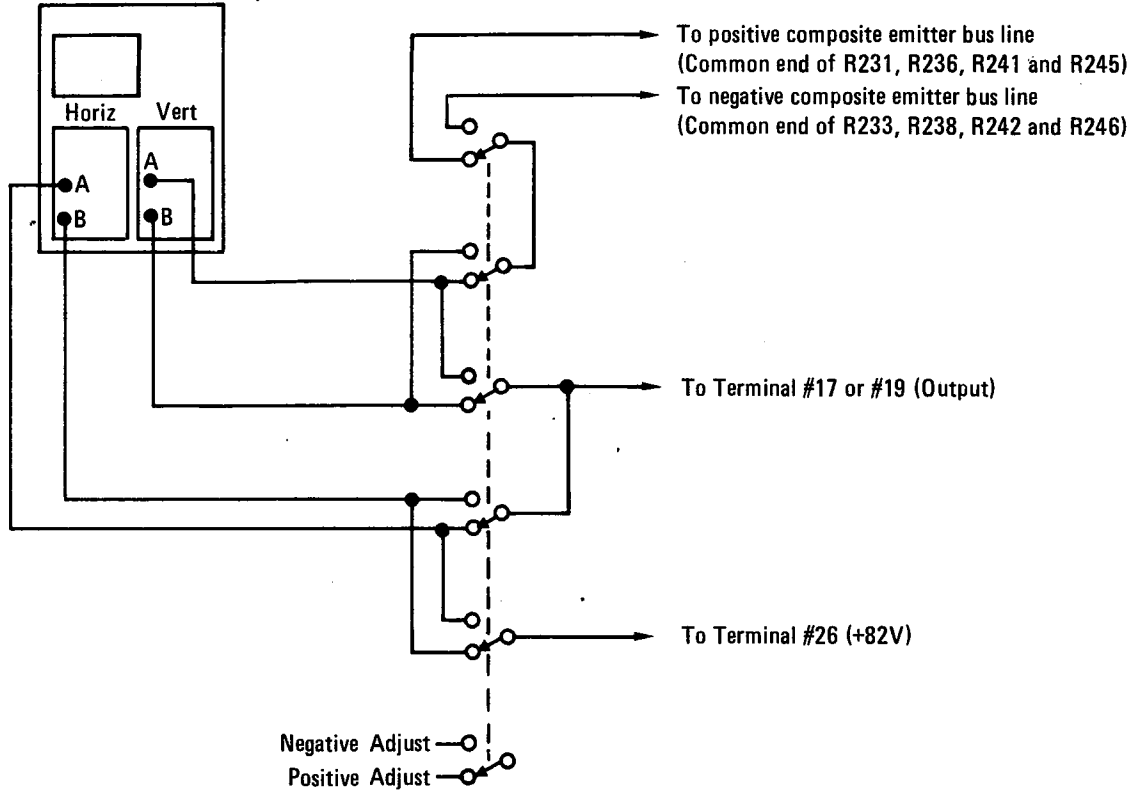

Figure 7. Oscilloscope Connection for S.O.A. Limit Adjustment

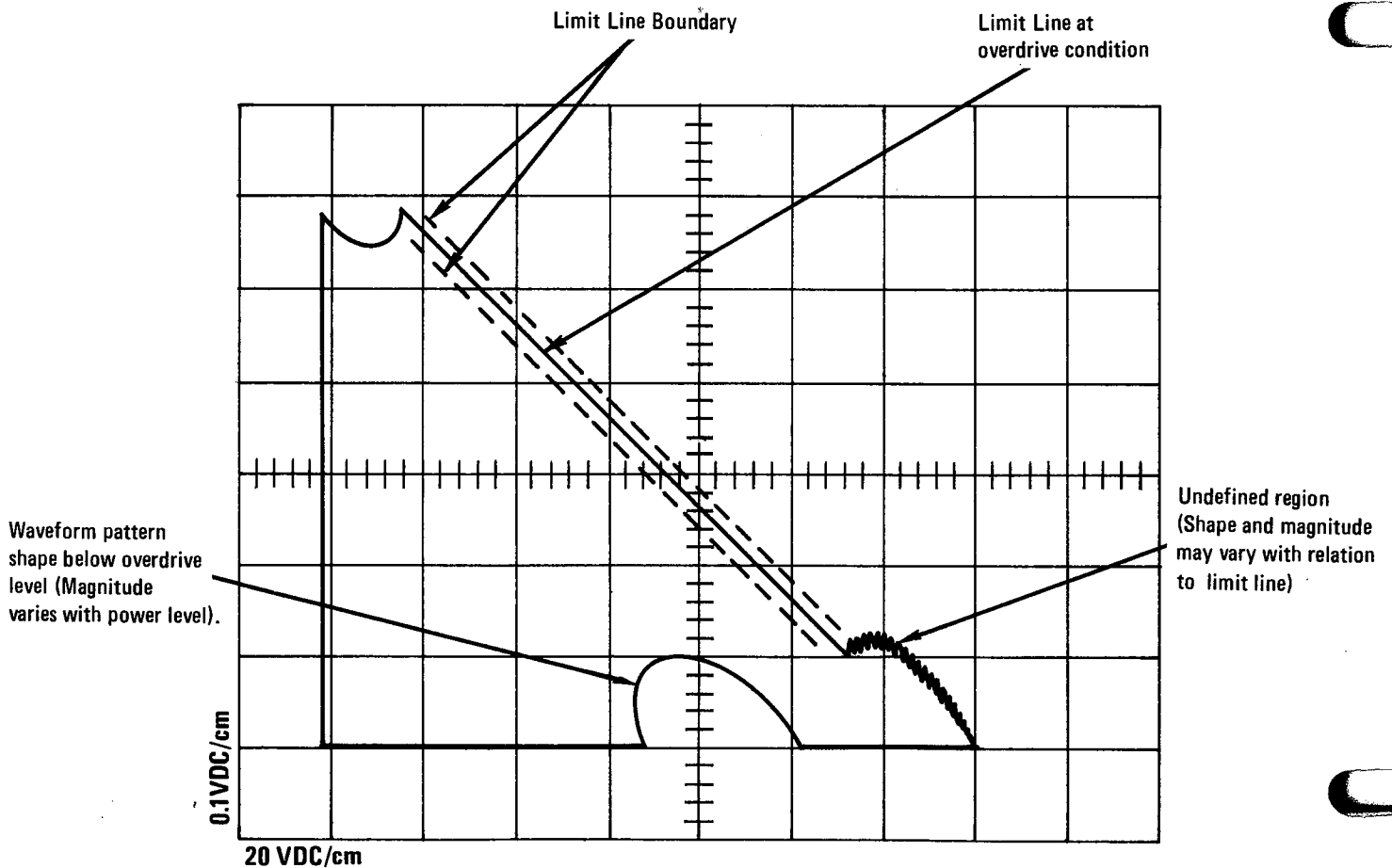

Figure 8. S.O.A. Limit Oscilloscope Display

3. With the AC power disconnected from the Model 500, connect the oscilloscope to the appropriate Power Amplifier circuit as shown in Figure 7. (Ref. Fig. 15.)

CAUTION: DURING TESTING HAZARDOUS VOLTAGES EXIST ON THE OSCILLOSCOPE CHASSIS.

4. Switch in the 8 ohm 60⁰ load. Connect the Audio Oscillator to the input jack of the channel being adjusted. Set the frequency at 2 kHz.
5. Apply 120 VAC 60 Hz power to the Model 500. Advance the oscillator level to drive the amplifier well into clipping (55 - 60V amplifier output; \approx 7V oscillator output).
6. The pattern displayed on the oscilloscope should be as shown in Figure 8 for both positive and negative halves of the complementary output circuit. With the switch (refer to Figure 7) in the "Positive Adjust" position, adjust R209 to bring the limit line voltage within the boundaries indicated in Figure 8; with the switch in the "Negative Adjust" position, adjust R213 for the negative half limit line.

IMPORTANT: TO PREVENT DAMAGE TO THE OSCILLOSCOPE OR AMPLIFIER, BEFORE SWITCHING FROM ONE "ADJUST" POSITION TO THE OTHER, REMOVE THE AC POWER FROM THE AMPLIFIER AND DISCHARGE THE FILTER CAPACITORS THROUGH THE

10-OHM BLEEDER RESISTOR. APPROXIMATELY 12 SECONDS IS REQUIRED TO FULLY DISCHARGE THE CAPACITORS.

7. Re-assemble the unit.

G. Meter Calibration.

1. Disassemble the unit to the point where the back side of the Front Panel Assembly is accessible. See the Service Notes section of this manual for disassembly instructions.
2. Apply the output of the Audio Oscillator to the input jack of the channel requiring adjustment. Set the frequency to 2 kHz and adjust the oscillator level for an amplifier output of 31.6V into the 8 ohm load.
3. Adjust R13 on the appropriate Meter Board until the meter indicates 0 dB \pm 0.5 dB. (See Figure 16.)
4. Adjust the oscillator frequency to 10 kHz and the level for 31.6 volts. If the meter indicates higher than 0 dB remove C13 from between terminals 9 and 10 on the Meter Board. Substitute lower values for C13 until the meter indicates 0 dB \pm 0.5 dB.
5. Adjust the frequency to 20 kHz and readjust the level, if necessary for 31.6V output. If the meter reads higher than 0 dB, remove C2 from between terminals 7 and 8 on the Meter Board. Substitute lower values for C2 until the meter indicates 0 dB \pm 0.5 dB.
6. Re-assemble the Model 500.

SERVICE NOTES

This section contains instructions for the disassembly of the Model 500 into its major component assemblies. Unless otherwise specified in the text, re-assembly of the unit is accomplished by following the instructions in reverse sequence. In all instances where the mounting means is not provided with a locking device (i.e. lockwasher, etc.) apply a small amount of Glyptal (P/N 641-1012-000) to the screw or nut. Included in the instructions for each major assembly are replacement procedures for those items which require special care or whose disassembly/re-assembly process is not obvious. In all cases, read all the instructions prior to attempting service.

Figures 9 and 10 show the location of all major components of the Model 500 within an assembled

unit. Figures 11 through 17 show the location of the individual parts within each major assembly.

This section also outlines the procedure for conversion of the 120V units for 100V or 220V operation, and contains a Parts List for items which are not part of a major component assembly.

A. DISASSEMBLY/RE-ASSEMBLY INSTRUCTIONS

1. Top Cover.

Remove the fourteen (14) #6-32 "sems" screws (P/N 769-1027-000) and the fourteen (14) #6 flat washers (P/N 670-4532-000) that secure the Top Cover in place. Thirteen screws are located around the outer edge of the cover and one is in the center of the cover, about 3" to the rear of the front panel.

MODEL 500

When replacing the Top Cover with a new part, ensure that the User Servicing Caution Label (P/N 585-1008-000) is affixed.

2. Bottom Cover

Remove the four (4) "feet" (P/N 567-1000-000) by removing the #6-32 x 1/2 screw (P/N 741-0812-000) securing the foot to the unit. Each screw is equipped with a #6 split-spring lockwasher (P/N 671-4330-000) and #6 flat washer (P/N 675-1009-000).

Remove the remaining eleven (11) #6-32 x 3/8 "sems" screws (P/N 769-1027-000) and eleven (11) #6 flat washers (P/N 670-4532-000). Ten of the screws are located around the outer edge of the cover and one is in the center, about 3" to the rear of the front panel.

When replacing the Bottom Cover with a new part, ensure that the User Servicing Caution Label (P/N 585-1008-000) is affixed.

3. Front Panel Assembly

Remove the top and bottom covers (ref. paragraphs 1 and 2).

Remove the two (2) #10 x 5/8 screws (P/N 761-1012-000), the two (2) #10 split-spring lockwashers (P/N 671-6562-000) and the two (2) #10 flat washers (P/N 670-6772-000) that secures each handle (P/N 174-1009-000) to the front panel.

The Front Panel Assembly is now free of the unit and may be rotated toward the bottom of the unit, to expose the rear of the panel and the front of the power supply assembly.

4. Pilot Lamp

Remove the top and bottom covers (ref. paragraphs 1 and 2).

Free the front panel assembly from the unit (ref. paragraph 3).

Rotate the lamp socket until the locking tabs on the socket align with the relieved areas of the mounting hole. The socket will "lift" slightly when properly aligned, and may be removed by lifting straight up.

Replace the bulb only with a #44 bulb (P/N 482-1006-000).

5. Meter Board Assembly

Remove the top and bottom covers (ref. paragraphs 1 and 2).

Free the front panel assembly from the unit (ref. paragraph 3).

Remove the two (2) #8-32 hex nuts (P/N 680-5340-000) that secure the Meter Board Assembly to the meter studs.

When re-installing the Meter Board Assembly, ensure that the meter board insulator (P/N 127-1021-000) is in place, and that the #8 external-tooth lockwashers (P/N 673-5510-000) are in place on the meter studs.

6. Meter

Remove the top and bottom covers (ref. paragraphs 1 and 2).

Free the front panel assembly from the unit (ref. paragraph 3).

Free the meter board assembly from the meter studs (ref. paragraph 5).

Remove the two (2) #6-32 x 1/4 screws (P/N 741-0410-000) and the two (2) #6 split-spring lockwashers (P/N 671-4330-000) that secure the meter shroud to the Meter.

Prior to installing a replacement Meter, remove the hex spacers (P/N 168-1009-000) from the back of the old Meter and install them on the new Meter.

After installing a replacement Meter, refer to the Adjustment Procedure section of this manual for calibration instructions.

7. Front Panel

Remove the sub-panel over the accessory chassis by exerting an outward force on the handle.

Remove the top and bottom covers (ref. paragraphs 1 and 2).

Remove the knobs from the four (4) controls using a #8 hex key wrench (allen wrench) to loosen the #8-32 set screw (P/N 775-3142-000) in each knob.

Free the front panel assembly from the unit (ref. paragraph 3).

Free the meter boards (ref. paragraph 5) and remove the meters (ref. paragraph 6).

Remove the #3/8-32 hex nut (P/N 680-8726-000) from the threaded bushing of each of the four (4) controls. Remove the Front Panel.

Remove the two (2) #6-32 hex nuts (P/N 680-4222-000) and the two (2) #6 split-spring lockwashers (P/N 671-4332-000)

that secure the panel plaque to the Front Panel. Remove the plaque.

8. Driver Board Assembly

Remove the top cover (ref. paragraph 1).

Remove the two (2) #4-40 x 5/16 screws (P/N 721-0512-000) and the two (2) #4 split-spring lockwashers (P/N 671-2232-000) that secure the Driver Board Assembly to the top heatsink bracket - refer to figure 9) for mounting screw location.

Unplug the Driver Board Assembly from the power amplifier board.

9. Rear Panel Assembly

Remove the top and bottom covers (ref. paragraphs 1 and 2).

Orient the unit on its right-hand side (the side nearest the line cord) with the rear of the unit overhanging the edge of the work-bench.

Remove the #6-32 x 3/8 "sems" screw (P/N 769-1027-000) and the #6 flat washer (P/N 670-4532-000) that secures the cable clamp located on the bottom heatsink bracket, at the rearmost corner nearest the output jacks.

Remove the two (2) #6-32 x 5/16 "sems" screws (P/N 769-1022-000) that secure the wireway bracket to the rear panel. The screws are located along the bottom edge of the rear panel, between the fuse post and the input jacks.

Remove the two (2) #10-32 x 7/16 screws (P/N 761-0712-000), the two (2) #10 split-spring lockwashers (P/N 671-6562-000) and the two (2) #10 flat washers (P/N 670-6772-000) that secure the rear panel to each side bracket. The screws are located at the rear of each side bracket.

The Rear Panel Assembly is now free of the unit and may be rotated towards the bottom of the unit to expose the inside of the panel and the Channel A power amplifier board.

10. Channel A Heatsink Component Assembly

This assembly contains all components of the Channel A power amplifier circuit; that is, the transistors mounted to the heatsink, with the power amplifier board attached.

Remove the top and bottom covers (ref. paragraphs 1 and 2).

Orient the unit on its right-hand side (the side nearest the line cord) with the rear of the unit overhanging the edge of the work-bench.

Free the rear panel assembly from the unit (ref. paragraph 9).

Remove the Channel A driver board assembly (ref. paragraph 8).

Remove the #6-32 x 5/16 screw (P/N 741-0510-000) and the #6 split-spring lockwasher (P/N 671-4330-000) that secures the grounding lug to the bottom heatsink bracket, just forward of the Channel A input jack.

Disengage the rearmost of the two "in-line" connectors located near the bottom heatsink bracket.

Remove the #6-32 x 7/16 screw (P/N 741-0712-000) and the #6 fibre flat washer (P/N 676-1007-000) that secures the tie-point terminal to the bottom heat-sink bracket; located in the area where the wireway bracket crosses over the heat-sink bracket. Remove the #6 fibre shoulder-washer (P/N 677-1005-000) from under the tie-point terminal.

Remove the #6-32 x 3/8 "sems" screw (P/N 769-1027-000) and the #6 flat washer (P/N 670-4532-000) that secures the cable clamp located on the bottom heatsink bracket, at the rearmost corner nearest the line cord.

Remove the four (4) #6-32 x 5/16 "sems" screws (P/N 769-1022-000) that secures the Channel A Heatsink Component Assembly to the top heatsink bracket.

Carefully remove the Heatsink Component Assembly from between the heat-sink brackets and remove the two (2) wires from the thermal switch (P/N 491-1001-000).

The Channel A Heatsink Component Assembly is now free of the unit and may be rotated toward the bottom of the unit to expose the heatsink-mounted transistors on both Channel A and Channel B heatsink assemblies.

11. Heatsink-Mounted Transistors

Remove the top and bottom covers (ref. paragraphs 1 and 2).

Remove the Channel A driver board assembly (ref. paragraph 8).

Free the rear panel assembly from the

unit (ref. paragraph 9).

Free the Channel A heatsink component assembly from the unit (ref. paragraph 10).

To remove the Driver (Q302, Q308) or Pre-Driver (Q301, Q307) transistor, remove the two (2) #6-32 x 9/16 screws (P/N 741-0910-000) and two (2) #6 split-spring lockwashers (P/N 671-4330-000) that secure the transistor in place. Remove the mica insulator (P/N 371-1007-000 for Q301/Q307, P/N 371-1006-000 for Q302/Q308) from under the transistor.

To remove an Output transistor, remove the two (2) #6-32 x 9/16 "sems" screws (P/N 789-1002-000) that secure the transistor in place. Remove the mica insulator (P/N 371-1006-000) from under the transistor.

When replacing any heatsink-mounted transistor, inspect the mica insulator and replace it if it is damaged. Apply an even coating of Wakefield Type 120 Thermal Compound (P/N 637-1002-000) to both sides of the insulator. Insert the transistor pins firmly into their respective sockets before re-installing the transistor mounting hardware.

When replacing the transistor on which the thermal switch (P/N 491-1001-000) is installed, apply a liberal amount of Wakefield Type 120 Thermal Compound between the thermal switch and the transistor case.

12. Channel A Power Amplifier Board Assembly

Remove the top and bottom covers (ref. paragraphs 1 and 2).

Free the rear panel assembly from the unit (ref. paragraph 9). -

Remove the Channel A driver board assembly (ref. paragraph 8).

Remove the #6-32 x 5/16 screw (P/N 741-0510-000) and the #6 split-spring lockwasher (P/N 671-4330-000) that secures the grounding lug to the bottom heatsink bracket, just forward of the Channel A input jack.

Disengage the rearmost of the two "in-line" connectors located near the bottom heatsink bracket.

While preventing the spacer (P/N 570-1007-000), located between the board and heatsink, from rotating remove the #4-40 x 1/4 screw (P/N 721-0412-000) and the #4 split-spring lockwasher (671-2232-000) located at each end of the board.

Remove the twelve (12) #6-32 hex nuts (P/N 680-4220-000) and the twelve (12) #6 split-spring lockwashers (P/N 671-4330-000) that secure the Power Amplifier Board to the heatsink.

Carefully disengage the Power Amplifier Board from the heatsink by exerting a force, directly away from the heatsink, along the entire length of the circuit board. (The Power Amplifier Board has 26 single spring-type connectors that mate with the pins of the heatsink-mounted transistors.)

The Channel A Power Amplifier Board is now free of the unit and may be rotated toward the bottom of the unit to expose the "copper-side" of the circuit board and the heatsink assembly.

When re-assembling the Power Amplifier Board to the heatsink, ensure that each single spring-type connector is properly aligned with its respective pin before applying any force to the circuit board. Also ensure that the #6 Internal-tooth lockwasher (P/N 672-4410-000) is in place, on each stud.

13. Heatsink Fan

Remove the top and bottom covers (ref. paragraphs 1 and 2).

Remove the Channel A driver board (ref. paragraph 8).

Free the rear panel assembly from the unit (ref. paragraph 9).

Free the Channel A heatsink component assembly from the unit (ref. paragraph 10).

Remove the four (4) #6-32 x 5/16 "sems" screws (P/N 769-1022-000) that secure the fan mounting plate to the heatsink brackets.

Carefully move the fan towards the rear of the unit until the fan line cord plug becomes exposed. Disengage the plug and remove the fan.

Prior to installing a replacement Fan (P/N 530-1000-000), remove the fan mounting plate (P/N 137-1004-000) and

the sponge rubber vibration isolator (P/N 129-1002-000) from the old Fan by removing the four (4) #6-32 x 3/4 flathead screws (P/N 741-1262-000), the four (4) #6 split-spring lockwashers (P/N 671-4332-000), and the four (4) #6-32 hex nuts (P/N 680-4222-000); re-install these items on the replacement Fan. Also remove the self-adhering sponge rubber vibration isolator (P/N 129-1003-000) from the inlet-end of the old Fan and affix it to the new Fan.

14. Channel B Heatsink Component Assembly

This assembly contains all components of the Channel B power amplifier circuit; that is, the transistors mounted to the heatsink, with the power amplifier board attached.

Remove the top and bottom covers (ref. paragraphs 1 and 2).

Remove the Channel A and Channel B driver boards (ref. paragraph 8).

Free the rear panel assembly from the unit (ref. paragraph 9).

Free the Channel A heatsink component assembly from the unit (ref. paragraph 10).

Remove the heatsink fan (ref. paragraph 13).

Remove the four (4) #6-32 x 7/16 screws (P/N 741-0712-000), the four (4) #6 split-spring lockwashers (P/N 671-4332-000) and the four #6 flat washers (P/N 670-4532-000) that secure the top heatsink bracket to both side plates (two screws per side).

Remove the four (4) #6-32 x 5/16 "sems" screws (P/N 769-1022-000) that secure the top heatsink bracket to the Channel B heatsink. Remove the bracket.

Disconnect the two wires from the Channel B thermal switch (P/N 491-1001-000).

Remove the #6-32 x 3/8 "sems" screw (P/N 769-1027-000) and the #6 flat washer (P/N 670-4532-000) that secure the cable clamp located on the bottom heatsink bracket, at the corner nearest the large filter capacitors.

Remove the remaining three screws that secure the Channel B Heatsink Component Assembly to the bottom heatsink bracket. The screws securing the two (2) grounding lugs are #6-32 x 5/16 (P/N 741-0510-000) and are equipped with a #6 split-spring lockwasher (P/N 671-4330-000); the remaining screw is a #6-32 x 5/16 "sems" (P/N 769-1022-000).

Disengage the remaining "in-line" connector located near the bottom heatsink bracket.

The Channel B Heatsink Component Assembly is now free of the unit and by moving the assembly directly toward the rear of the unit until it is clear of the side brackets, may be rotated toward the top of the unit to expose the component side of the Channel B power amplifier board and the rear of the power supply assembly.

15. Channel B Power Amplifier Board Assembly

The Channel B Power Amplifier Board Assembly is separated from (and re-assembled to) the Channel B heatsink in the same fashion as the Channel A power amplifier board is separated from (and re-assembled to) the Channel A heatsink (ref. paragraph 12).

16. Rectifier/Relay Board

Remove the top and bottom covers (ref. paragraphs 1 and 2).

Remove the Channel A and Channel B driver boards (ref. paragraph 8).

Free the rear panel assembly from the unit (ref. paragraph 9).

Free the Channel A and Channel B heatsink component assemblies from the unit (ref. paragraphs 10 and 14).

Remove the four (4) #6-32 x 5/8 screws (P/N 741-1012-000) and the four (4) #6 split-spring lockwashers (P/N 671-4332-000) that secure the AC terminal block to the bottom heatsink bracket.

Remove the four (4) #6-32 x 7/16 screws (P/N 741-0712-000), the four (4) #6 split-spring lockwashers (P/N 671-4332-000) and the four #6 flat washers (P/N

670-4532-000) that secure the bottom heatsink bracket to both side plates. Remove the heatsink bracket, and the vent screens (P/N 160-1000-000) from each side bracket.

Remove the #6-32 x 2-3/4 (P/N 740-4422-000), the #6-32 hex nut (P/N 680-4220-000), the #6 split-spring lockwasher (P/N 671-4332-000) and the spacer (P/N 559-4360-000) that secure the Rectifier-Relay Board to the wireway bracket.

Remove the two (2) #6-32 x 7/16 screws (P/N 784-7132-000) and the two #6 split-spring lockwashers (P/N 671-4330-000) that secure the Rectifier-Relay Board to the power supply assembly chassis.

The board is now free of the unit and, by rotating it toward the bottom of the unit, both sides may be exposed.

7. Power Supply Assembly

Removal of the Power Supply Assembly from the unit for service, is not recommended. However, both sides of the assembly may be exposed by disassembling the unit to the point where the Front Panel Assembly and the Channel B Heatsink Component Assembly are free of the unit.

VOLTAGE CONVERSION INSTRUCTIONS

1. The instructions set forth below are applicable for the conversion of 120V units for operation at a line voltage of 100 VAC or 220 VAC. The unit has provisions for making the conversion without the use of a soldering iron. The degree of disassembly required to perform the conversion is as follows:

Remove the top and bottom cover (ref. paragraphs 1 and 2 of Disassembly/Re-assembly Instructions).

Expose TB3 on the Power Supply Assembly by freeing the Front Panel Assembly from the unit (ref. paragraph 3 of Disassembly/Re-assembly Instructions).

2. 100 VAC Conversion

Identify terminal 1 of TB3. (The black wire from the transformer is connected to this terminal.)

Remove the white AC lead-in wire from terminal 1 of TB3.

Remove the jumper strap from between terminals 1 and 2 of TB3.

Install the jumper strap between terminals 3 and 4 of TB3.

Install the white AC lead-in wire to terminal 3 of TB3.

Re-assemble the unit and affix the labels, supplied in the 100 VAC conversion kit (P/N 103-1013-000), to the rear panel of the unit.

The Model 500 is now ready for 100V operation.

3. 220 VAC Conversion

Identify terminal 1 of TB3. (The black wire from the transformer is connected to this terminal.)

Remove the jumper strap from between terminals 5 and 6 of TB3, leaving the brown AC lead-in wire installed at terminal 6.

Remove the white AC lead-in wire from terminal 1 of TB3.

Remove, and discard, the jumper strap from between terminals 1 and 2 of TB3.

Install the white AC lead-in wire to terminal 2 of TB3.

Replace the 15-amp, 250V fuse in the unit with the 10-amp, 250V fuse (P/N 451-1017-000) supplied with the 220 VAC conversion kit (P/N 103-1015-100).

Re-assemble the unit and affix the labels, supplied in the conversion kit, to the rear panel of the unit.

The Model 500 is now ready for 220V operation.

C. Parts List

Listed on P18 are those parts (except major sub-assembly components) which might be required for service or maintenance of the Model 500. Components of major sub-assemblies are contained in separate lists which appear adjacent to the figure depicting the sub-assembly.



Line Fuse

J3
Channel B
Input



J1
Channel A
Input

TB6
Channel B
Output

TB4
Channel A
Output



Panel Assy
Fig. 11)

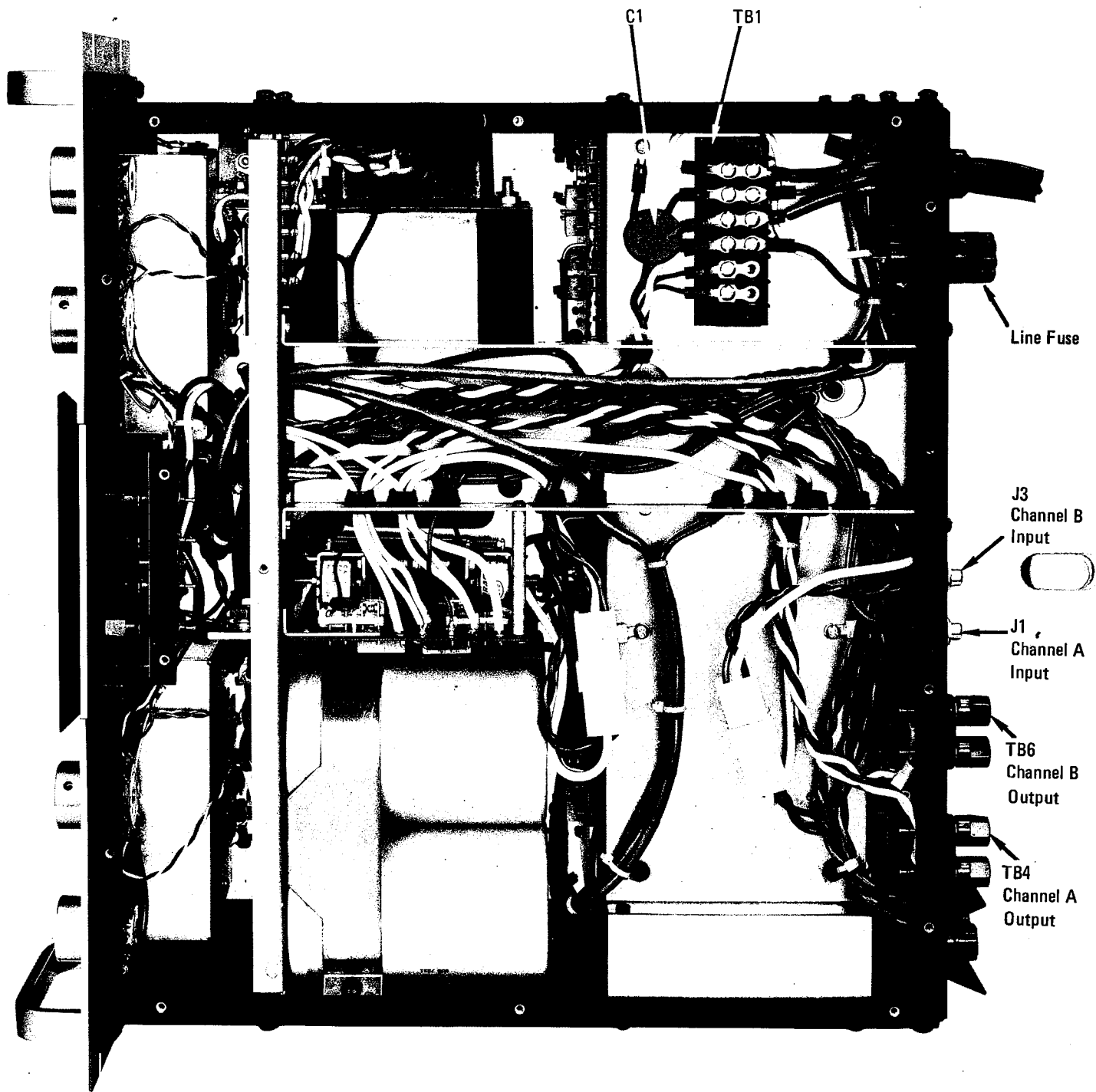

Figure 10. Model 500 Interior View-Bottom

MODEL 500

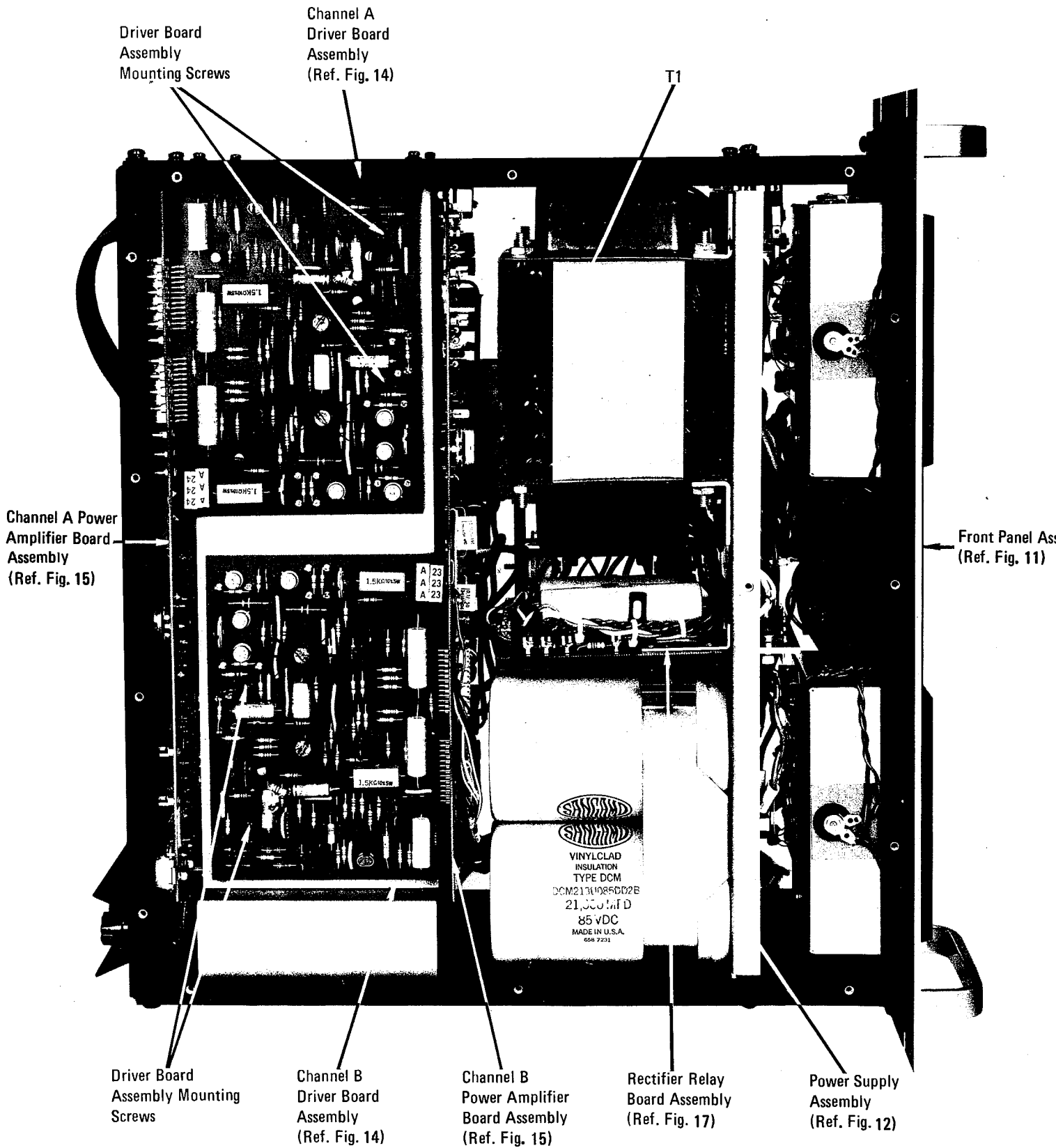

Figure 9. Model 500 Interior View-Top

Description	Part Number
Ball Stud	570-1001-000
Binding Post, Output (TB4, TB6)	359-1003-000
Bracket, Heatsink (Bottom)	132-1014-100
Bracket, Heatsink (Top)	132-1014-300
Bushing, Strain Relief	565-1003-000
Bushing, Wire Protection	565-1006-000
Capacitor, 0.01 μ fd, 1400V (C1)	383-1006-000
Compound, Thermal	637-1002-000
Connector Contact	365-1017-000
Connector, Female (In-Line)	360-1049-000
Connector, Male (In-Line)	360-1048-000
Connector, Thermal Switch	366-1000-000
Cover, Bottom	136-1016-000
Cover, Top	136-1015-000
Fan	530-1000-000
Foot	567-1000-000
Fuse, 5A (Fast-Acting)	451-1018-000
Fuse, 15A	451-1011-000
Fuse Post (Line)	367-1002-000
Fuse Post (Supply)	342-1000-000
Glyptal	641-1011-000
Handle	174-1009-000
Handle, Access Panel	174-1006-000
Insulator, Lamp Socket (Top Cover)	127-1018-000
Isolator, Fan-to-Chassis	129-1003-000
Isolator, Fan-to-Heatsink	129-1002-000
Jack, Phono-Input (J1, J3)	360-1014-000
Knob	174-1001-000
Label, Caution (User Servicing)	585-1008-000
Line Cord - Fan	361-1003-000
Line Cord - Unit (P1)	361-1002-000
Lug, Terminal Block	365-4402-000
Manual, Owner's	199-1055-000
Marker Strip, Modified	127-1022-000
Nut, Hex, #6-32, Blk	680-4222-000
Nut, Hex, #3/8-32	680-8726-000
Packing Set	198-1029-000
Panel, Access	134-1018-000
Plate, Fan Mtg	137-1004-000
Plate, Left Side	137-1007-000
Plate, Rear	137-1006-000
Plate, Right Side	137-1008-000
Schematic, Unit	199-1095-000
Screen, Vent	160-1000-000
Screw, #4-40 x 5/16", Blk	721-0512-000
Screw, #6-32 x 5/16", Cad	741-0510-000
Screw (Sems), #6-32 x 5/16", Blk	769-1022-000
Screw (Sems), #6-32 x 3/8", Blk	769-1027-000
Screw, #6-32 x 7/16", Blk	741-0712-000
Screw, #6-32 x 1/2", Blk	741-0812-000
Screw, #6-32 x 5/8", Blk	741-1012-000
Screw, Flat Hd, #6-32 x 3/4", Blk	741-1262-000
Screw, #6-32 x 2 3/4", Blk	740-4422-000
Screw, Set, #8-32 x 1/4"	775-3142-000
Screw, #10-32 x 7/16", Blk	761-0712-000
Screw, #10-32 x 5/8", Blk	761-1012-000
Shroud, Fuse (Supply)	136-1042-000
Spacer, #6 x 2 1/4"	559-4360-000

Description	Part Number
Template, Mounting	199-1056-000
Terminal Block (TB1)	363-1002-000
Terminal, Insulated Ring, 10-12 AWG, #6 Ring Dia	365-9451-000
Terminal, Insulated Ring, 14-16 AWG, #6 Ring Dia	365-9430-000
Terminal, Non-insulated Ring, 14-16 AWG, #6 Ring Dia	365-8430-000
Terminal, Insulated Ring, 16-22 AWG, #6 Ring Dia	365-9420-000
Terminal, Insulated Ring, 10-12 AWG, #10 Ring Dia	365-9850-000
Terminal, Insulated Ring, 10-12 AWG, #1/4 Ring Dia	365-2007-000
Terminal, Insulated Ring, 16-22 AWG, # 1/4 Ring Dia	365-2009-000
Terminal, Insulated Ring, 10-12 AWG, #5/16 Ring Dia	365-2008-000
Terminal, Insulated Ring, 14-16 AWG, #5/16 Ring Dia	365-2010-000
Terminal, Insulated Ring, 16-22 AWG, #5/16 Ring Dia	365-2011-000
Washer, Fibre, Flat	676-1007-000
Washer, Fibre, Shoulder	677-1005-000
Washer, Fibre, Shoulder (Input Jack)	677-1001-000
Washer, Flat, #6, Blk	670-4532-000
Washer, Flat #6, Blk (Small)	675-1009-000
Washer, Flat, #10, Blk	670-6772-000
Washer, Lock, #4, Blk	671-2232-000
Washer, Lock, #6, Blk	671-4332-000
Washer, Lock, #6, Cad	671-4330-000
Washer, Lock, #10, Blk	671-6562-000
Washer, Toothed, #6, Cad	672-4410-000

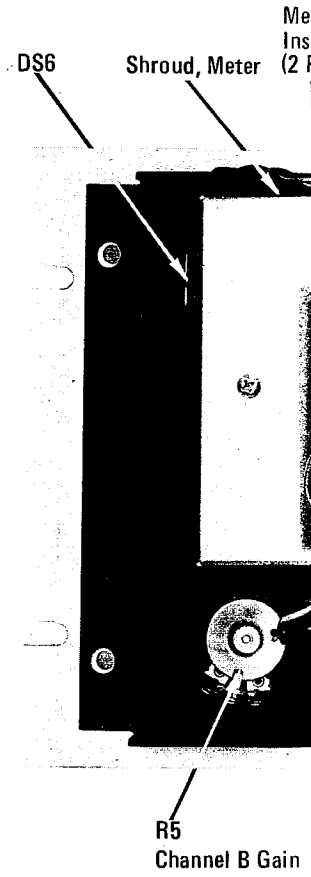

Figure 11. Front

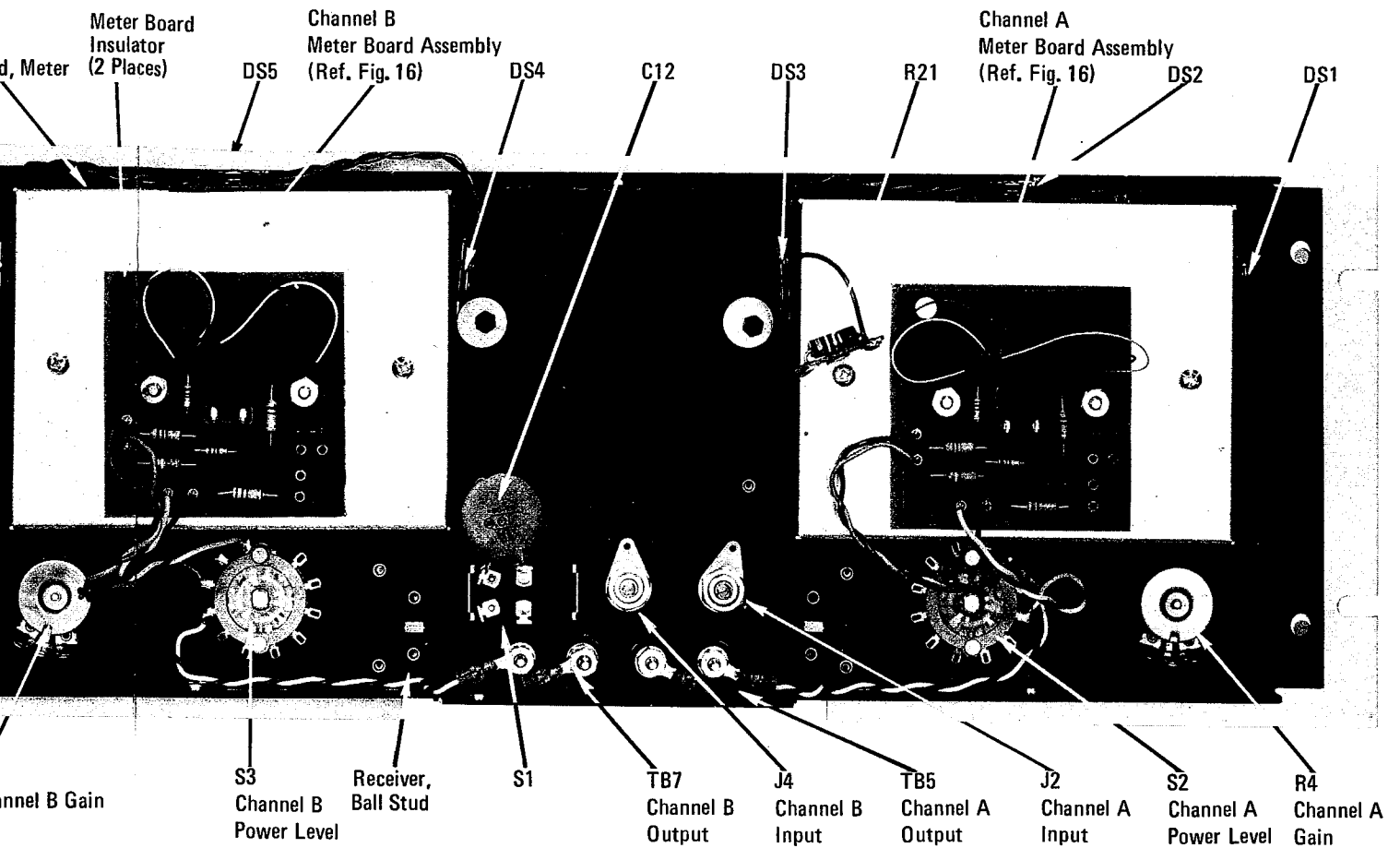

Figure 11. Front Panel Assembly - Rear View

FRONT PANEL ASSEMBLY PARTS LIST

Description	Part Number
Binding Post (TB5, TB7)	359-1003-000
Capacitor, 0.01 μ fd, 1400V (C12)	383-1006-000
Insulator, Lamp Socket	127-1024-000
Insulator, Meter Board	127-1021-000
Jack, Phono-Input (J2, J4)	360-1014-000
Lamp	482-1006-000
Meter (M1, M2)	855-1000-000
Nut, Hex, #6-32, Blk	680-4222-000
Nut, Hex, #6-32, Cad	680-4220-000
Nut, Hex, #8-32, Cad	680-5340-000
Nut, Hex, #3/8-32	680-8726-000
Nut, Hex, #15/32-32	680-9821-000
Panel, Front	134-1017-000
Panel, Plaque	134-1019-000
Potentiometer - Gain (R4, R5)	420-1034-000

Description	Part Number
Receiver, Ball Stud	570-1002-000
Resistor, 0.39 $\Omega \pm 5\%$, 2W (R21)	436-0392-000
Rivet, Flat Head, 5/32 Lg	664-1000-000
Rivet, Flat Head, 7/32 Lg	664-1001-000
Screw, #6-32 x 1/4, Cad	741-0410-000
Screw, #6-32 x 5/16, Cad	741-0510-000
Shroud, Meter	136-1020-000
Socket, Lamp	481-1003-000
Spacer, Male/Female, #6-32	168-1009-000
Switch, Rotary (S2, S3)	453-1019-000
Switch, Toggle (S1)	452-1018-000
Terminal Strip	362-1000-000
Washer, Fibre, Shoulder	677-1001-000
Washer, Flat, #6, Cad	670-4550-000
Washer, Lock # 6, Blk	671-4332-000
Washer, Lock, #6, Cad	671-4330-000
Washer, Toothed, #6, Cad	672-4410-000
Washer, Toothed, #8, Cad	673-5510-000
Washer, Toothed, #3/8, Cad	672-8716-000
Washer, Toothed, #15/32, Cad	675-1012-000

MODEL 500

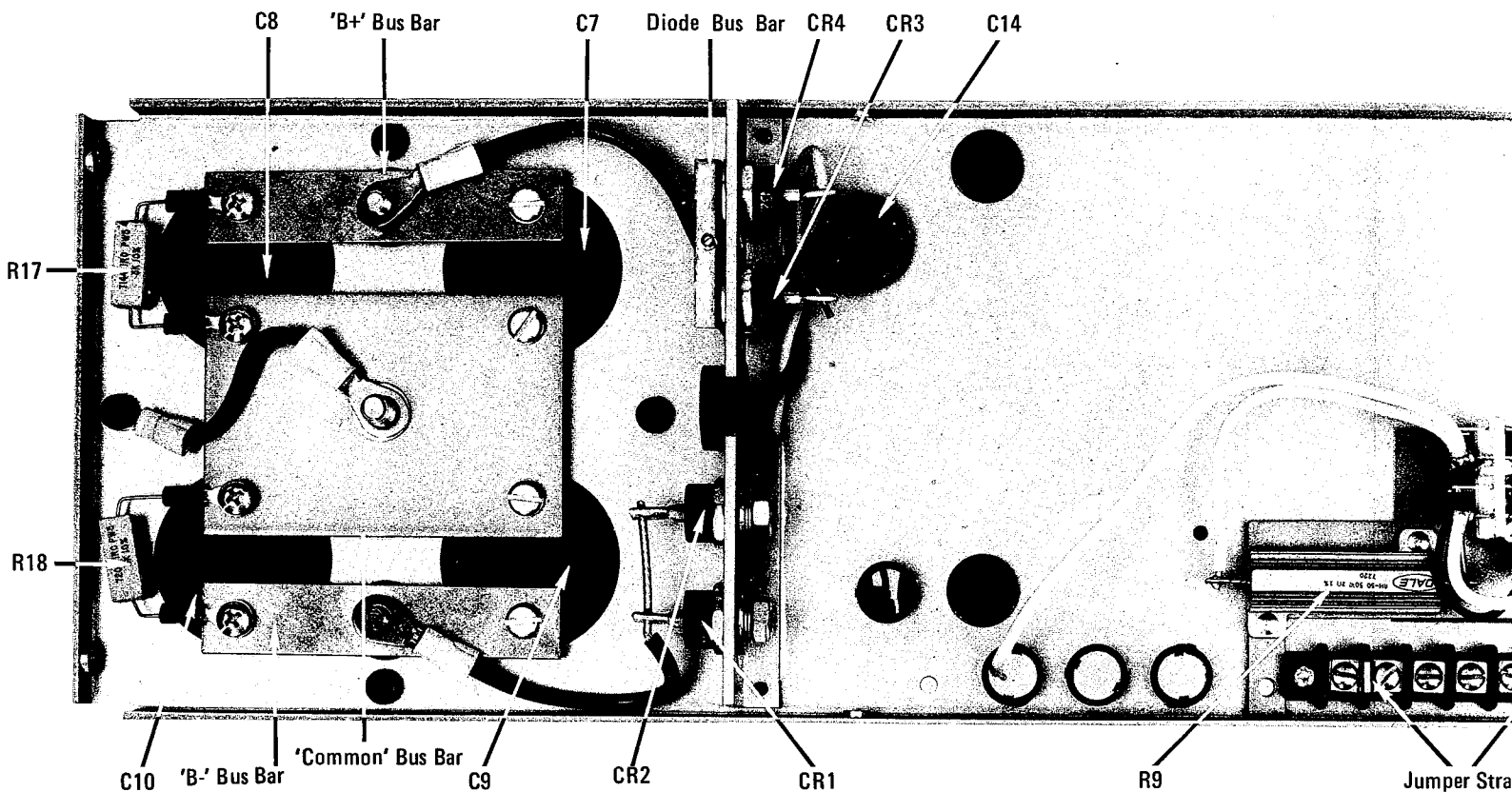
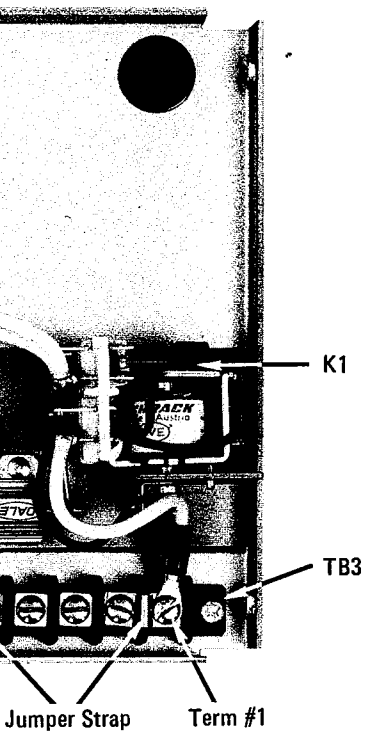

Figure 12. Power Supply Assembly

Description	Part Number
Bracket, Relay Mounting	132-1048-000
Bus Bar (B+, B-)	150-1002-000
Bus Bar (Common)	150-1005-000
Bus Bar, Diode	150-1006-000
Capacitor, 21,000 μ fd, 85V (C7-C10)	381-1065-000
Capacitor, 0.01 μ fd, 1400V (C4)	383-1006-000
Clamp, Capacitor	132-1033-000
Compound, Thermal	637-1002-000
Diode, Rectifier (CR1-CR4)	460-1012-000
Grommet, Plastic, 5/8 I.D.	565-1004-000
Grommet, Plastic, 7/8 I.D.	565-1008-000
Insulator, Relay	127-1023-000
Jumper Strap (Terminal Block)	365-1011-000
Nut, Hex, #6-32, Cad	680-4220-000
Nut, Hex, Keps, #10-32, Blk	689-1012-000
Nut, Hex, #12-24, Blk	689-1008-000
Nut, Hex, #1/4-20, Blk	689-1011-000
Nut, Hex, #1/4-20, Brass	680-7669-000
Nut, Hex, #5/16-18, Brass	689-1009-000

Description	Part Number
Relay, DPDT (K1)	410-1000-000
Resistor, 2 Ω ±1%, 50W (R9)	439-1020-000
Resistor, 3K ±10%, 5W (R17, R18)	428-4303-000
Rivet, 1/8 Dia x 7/32 Lg	655-4076-000
Screw, #6-32 x 3/8, Blk	784-6132-000
Screw, #6-32 x 7/16, Blk	784-7132-000
Screw, Sems, #6-32 x 9/16, Blk	789-1005-000
Screw, #10-32 x 7/16, Blk	761-0712-000
Screw, #10-32 x 5/8, Blk	761-1012-000
Screw, Hex Hd, #1/4-20 x 5/8, Blk	769-1011-000
Screw, Hex Hd, #1/4-20 x 5/8, Brass	769-1023-000
Screw, Hex Hd, #5/16-18 x 3/4	769-1024-000
Terminal Block (TB3)	363-1005-000
Terminal, Ring, Insulated, 18-22 Awg, #10 Stud	365-9822-000
Transformer, Power (T1)	440-1005-000
Washer, Flat, #1/4, Blk	675-1004-000
Washer, Flat, #1/4, Brass	670-7859-000
Washer, Lock, #6, Blk	671-4332-000
Washer, Lock, #10, Blk	671-6562-000
Washer, Lock, #12, Blk	675-1008-000
Washer, Lock, #1/4, Blk	671-7762-000
Washer, Toothed, #1/4, Bronze	675-1005-000
Washer, Toothed, #5/16, Bronze	675-1006-000



Description	Part Number
Bus Bar, Collector (Negative Half)	132-1032-200
Bus Bar, Collector (Positive Half)	132-1032-100
Bushing, Transistor Mtg Screw	127-1013-000
Clamp, Thermal Switch	132-1046-000
Compound, Thermal	637-1002-000
Diode — MZ2361 (CR301)	460-1015-000
Diode — SZ51066K (CR302)	460-1004-000
Insulator, Terminal Strip	127-1020-000
Insulator, Transistor (TO-3)	371-1006-000
Insulator, Transistor (TO-66)	371-1007-000
Nut, Hex, #6-32, Cad	680-4220-000
Resistor, 300Ω±5%, 1/4W	434-3302-000
Screw, #4-40 x 1/4, Blk	721-0412-000
Screw, #6-32 x 9/16, Cad	741-0910-000
Screw, Sems, #6-32 x 9/16, Cad	789-1002-000
Screw, #6-32 x 5/8, Cad	741-1010-000
Spacer, Male/Female, #4-40	570-1007-000
Spacer, Male/Female, #6-32	168-1008-000
Switch, Thermal (S301)	491-1001-000
Terminal, Feed-Thru	365-1018-000
Terminal Strip	362-1015-100
Transistor (Q301)	462-1025-
Transistor (Q302)	461-1018-
Transistor (Q303-Q306)	462-1023-
Transistor (Q307)	461-1019-
Transistor (Q308)	462-1024-
Transistor (Q309-Q312)	461-1017-
Washer, Lock, #4, Blk	671-2232-000
Washer, Lock, #6, Cad	671-4330-000
Washer, Toothed, #6, Cad	672-4410-000

For applicable dash number, see Transistor Specification Chart on Unit Schematic (Figure 18)

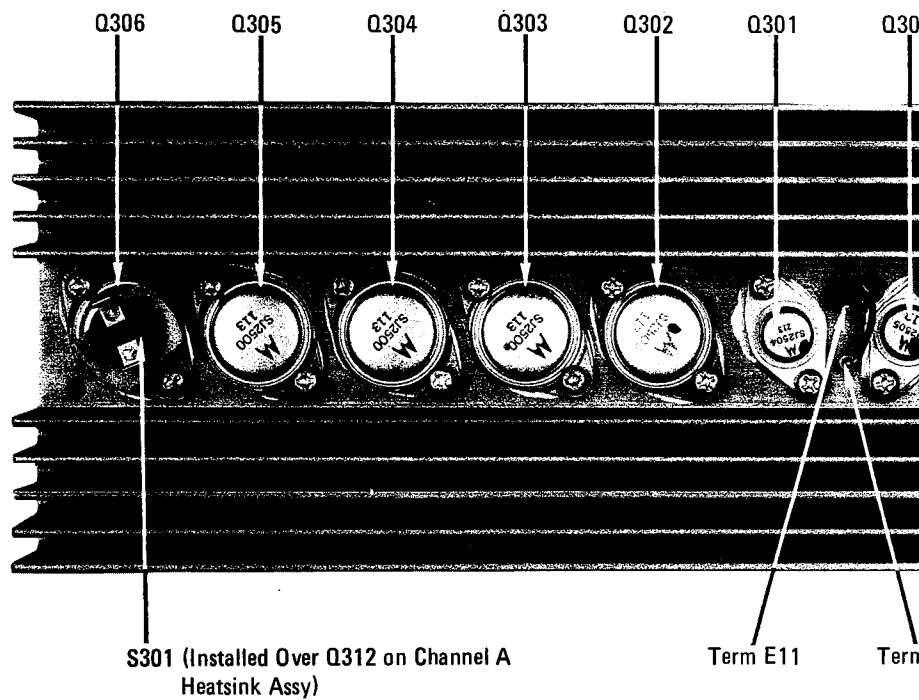

Channel B Heatsink Assembly Shown
(Same as Channel A Except as Noted)

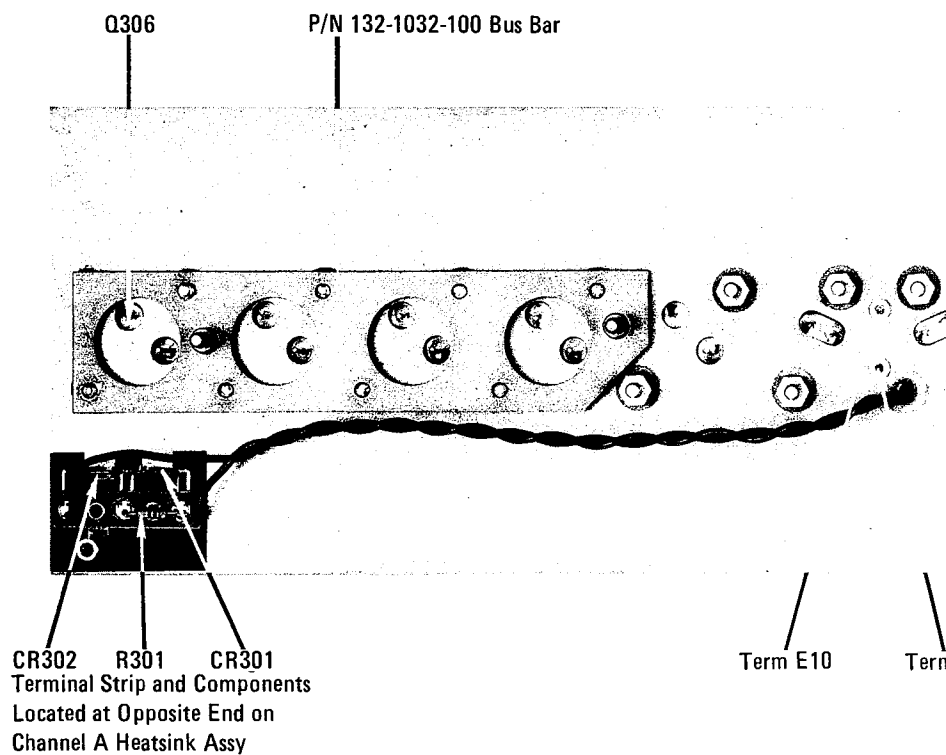
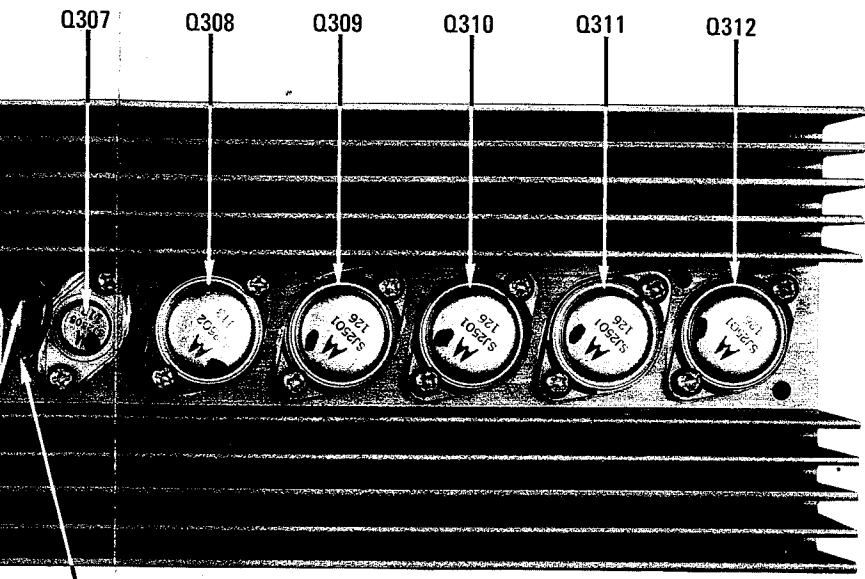

Figure 13. Heatsink Component Assembly



Q307

Q308

Q309

Q310

Q311

Q312

Term E10

P/N 132-1032-200 Bus Bar

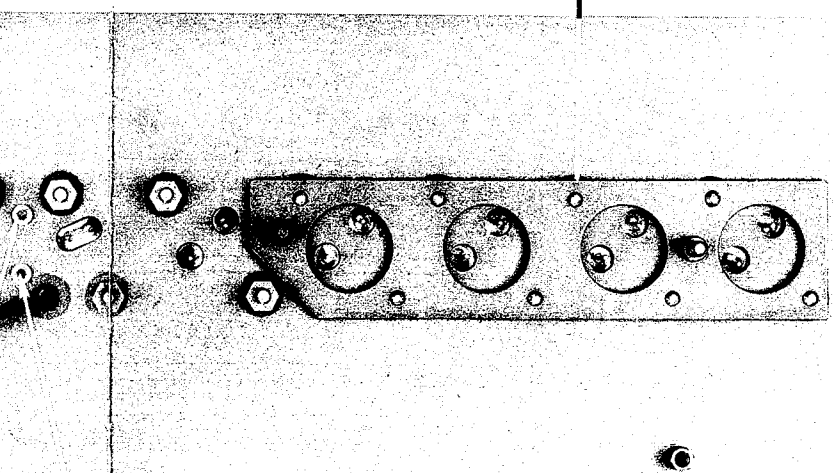

Term E11

MODEL 500

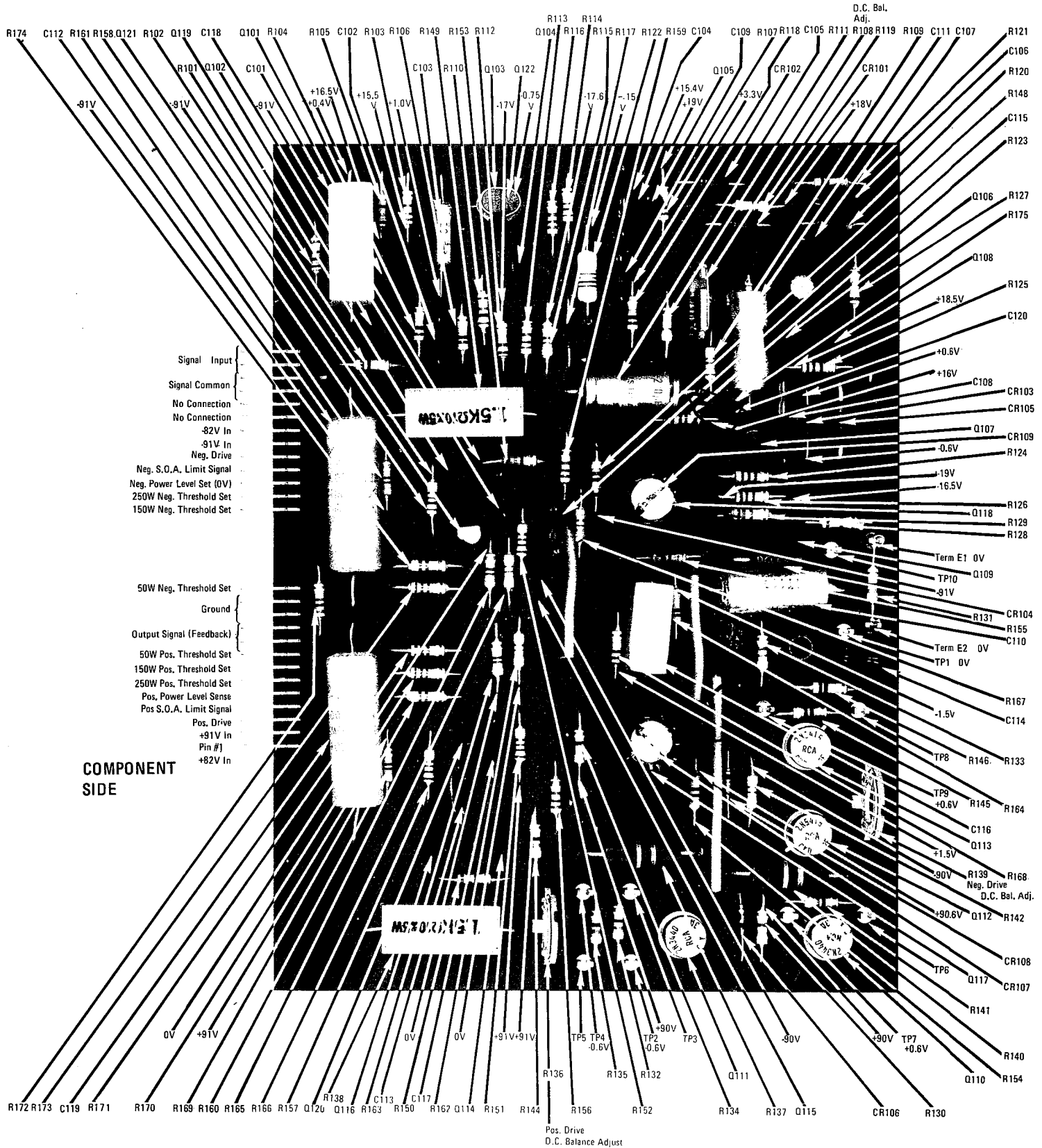
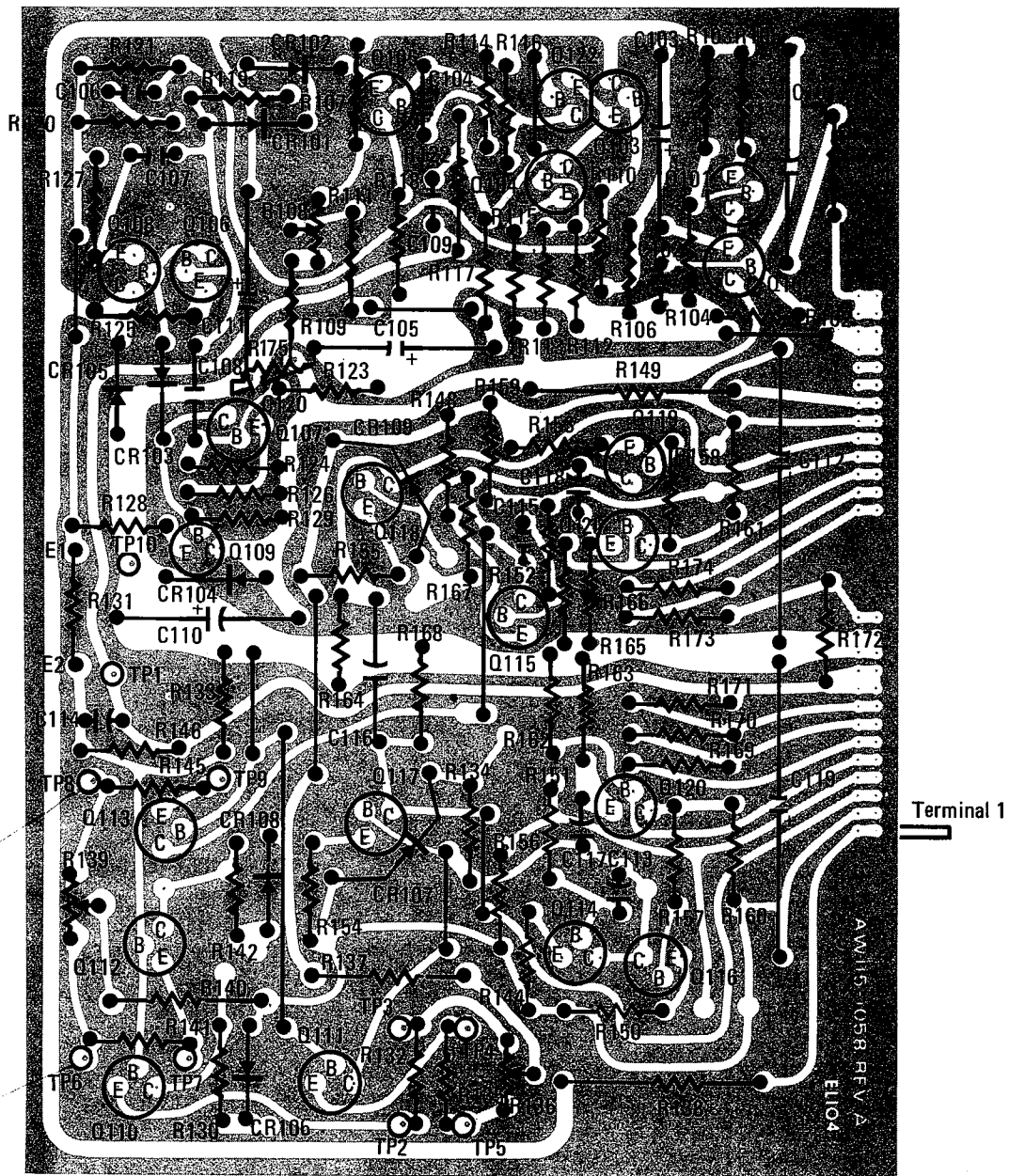

Figure 14. Driver Board Assembly (A1)

- 7 R121
- C106
- R120
- R148
- C115
- R123
- Q106 R127
- R175
- Q108
- R125
- C120
- C108 CR103
- CR105
- Q107 CR109
- R124
- R126
- Q118 R129
- R128
- 0V Q109
- CR104
- R131
- R155
- 0V C110
- R167
- C114
- 146 R133
- 145 R164
- C116
- Q113
- 139 R168
- eg. Drive
- D.C. Bal. Adj.
- Q112 R142
- CR108
- 117 CR107
- 141
- R140
- 10 R154



CIRCUIT SIDE







Figure 14. Driver Board Assembly (Cont.)

Notes:

1. Voltages are d.c. volts to ground, measured on a typical unit.
2. Configuration shown is applicable to circuit boards fabricated from A/W 115-1058, Rev. A.
3. Transistor pair Q103-Q122 to be equally spaced off board with their entire flat surfaces in intimate contact. P/N 562-1005-000 Thermal Retainer to be installed on pair.
4. P/N 562-1006-000 Thermal Dissipater to be installed on Q117 & Q113.
5. CR107 & CR109 to be in intimate contact with case of Q117 & Q118, respectively, with P/N 637-1001-000 Thermal Compound between mating surfaces. CR107 & CR109 leads to be insulated with #22 AWG, PVC sleeving.
6. P/N 372-1000-000 Insulator to be installed beneath Q110, Q111, Q112, Q113, Q117 & Q118.

Des.	Description	Part Number
A1	Driver Board Assembly	200-1058-100
C101	Cap., 1.0 μ fd \pm 10%, 100V	386-1018-000
C102	Cap., 150 pfd \pm 10%, 100V	385-1038-000
C103	Cap., Elect., 10 μ fd, 20V	381-1068-000
C104	Cap., 2000 pfd \pm 10%, 100V	385-1046-000
C105	Cap., Elect., 220 μ fd, 6.3V	381-1044-000
C106	Cap., 270 pfd \pm 10%, 100V	385-1037-000
C107	Cap., 15 pfd \pm 10%, 100V	385-1072-000
C108	Cap., 0.01 μ fd \pm 10%, 100V	385-1032-000
C109	Cap., 27 pfd \pm 10%, 100V	385-1036-000
C110	Cap., Elect., 47 μ fd, 35V	381-1069-000
C111	Cap., Elect., 47 μ fd, 35V	381-1069-000
C112	Cap., Elect., 18 μ fd, 100V	381-1066-000
C113	Cap., 150 pfd \pm 10%, 100V	385-1038-000
C114	Cap., 2.5 pfd \pm 10%, 100V	385-1076-000
C115	Cap., 130 pfd \pm 10%, 100V	385-1073-000
C116	Cap., 0.22 μ fd \pm 10%, 250V	386-1001-000
C117	Cap., 68 pfd \pm 10%, 100V	385-1074-000
C118	Cap., 68 pfd \pm 10%, 100V	385-1074-000
C119	Cap., Elect., 18 μ fd, 100V	381-1066-000
C120	Cap., Elect., 100 μ fd, 3V	381-1018-000
CR101	Diode	460-1015-000
CR102	Diode	460-1015-000
CR103	Diode	460-1015-000
CR104	Diode	459-1005-000
CR105	Diode	459-1005-000
CR106	Diode	460-1018-000
CR107	Diode	460-1016-000
CR108	Diode	460-1018-000
CR109	Diode	460-1016-000

Des.	Description	Part Number
Q101	Transistor	461-1013-000
Q102	Transistor	461-1013-000
Q103	Transistor	462-1038-200
Q104	Transistor	462-1042-000
Q105	Transistor	461-1013-000
Q106	Transistor	461-1037-000
Q107	Transistor	462-1044-000
Q108	Transistor	462-1009-000
Q109	Transistor	461-1006-000
Q110	Transistor	462-1056- Δ
Q111	Transistor	462-1056- Δ
Q112	Transistor	461-1049- Δ
Q113	Transistor	461-1049- Δ
Q114	Transistor	461-1036-000
Q115	Transistor	462-1042-000
Q116	Transistor	461-1036-000
Q117	Transistor	461-1049- Δ
Q118	Transistor	462-1056- Δ
Q119	Transistor	462-1042-000
Q120	Transistor	462-1058-000
Q121	Transistor	461-1050-000
Q122	Transistor	462-1038-200
R101	Res., 1K \pm 2%, 1/4W	434-4101-000
R102	Res., Metal Film, 100K \pm 2%, 1/4W	431-6101-000
R103	Res., 2.2K \pm 5%, 1/4W	434-4222-000
R104	Res., 10K \pm 5%, 1/4W	434-5102-000
R105	Res., 2.7K \pm 5%, 1/4W	434-4272-000
R106	Res., 100K \pm 5%, 1/4W	434-6102-000
R107	Res., 10K \pm 5%, 1/4W	434-5102-000
R108	Res., Var., 2.5K \pm 20%, 1/4W	420-1029-000
R109	Res., 6.8K \pm 5%, 1/4W	434-4682-000
R110	Res., 1K \pm 2%, 1/4W	434-4101-000
R111	Res., 470K \pm 5%, 1/4W	434-6472-000
R112	Res., 15K \pm 5%, 1/4W	434-5152-000
R113	Res., 2K \pm 5%, 1/4W	434-4202-000
R114	Res., 100 Ω \pm 5%, 1/4W	434-3102-000
R115	Res., 820 Ω \pm 5%, 1/4W	434-3822-000
R116	Res., 6.8K \pm 5%, 1/4W	434-4682-000
R117	Res., Metal Film, 1K \pm 1%, 1/4W	439-1017-000
R118	Res., 10K \pm 5%, 1/4W	434-5102-000
R119	Res., 3.3K \pm 5%, 1/4W	434-4332-000
R120	Res., 1K \pm 5%, 1/4W	434-4102-000
R121	Res., Metal Film, 100K \pm 2%, 1/4W	431-6101-000
R122	Res., Metal Film (T9), 20K \pm 2%, 1/2W	432-5201-000
R123	Res., 6.2K \pm 5%, 1/4W	434-4622-000
R124	Res., 1.2K \pm 5%, 1/4W	434-4122-000
R125	Res., 56 Ω \pm 5%, 1/4W	434-2562-000
R126	Res., 510 Ω \pm 5%, 1/4W	434-3512-000
R127	Res., 6.8 Ω \pm 5%, 1/4W	434-1682-000
R128	Res., 6.8 Ω \pm 5%, 1/4W	434-1682-000
R129	Res., 5.6K \pm 5%, 1/4W	434-4562-000

Des.	Description	Part Number
Q101	Transistor	461-1013-000
Q102	Transistor	461-1013-000
Q103	Transistor	462-1038-200
Q104	Transistor	462-1042-000
Q105	Transistor	461-1013-000
Q106	Transistor	461-1037-000
Q107	Transistor	462-1044-000
Q108	Transistor	462-1009-000
Q109	Transistor	461-1006-000
Q110	Transistor	462-1056- 
Q111	Transistor	462-1056- 
Q112	Transistor	461-1049- 
Q113	Transistor	461-1049- 
Q114	Transistor	461-1036-000
Q115	Transistor	462-1042-000
Q116	Transistor	461-1036-000
Q117	Transistor	461-1049- 
Q118	Transistor	462-1056- 
Q119	Transistor	462-1042-000
Q120	Transistor	462-1058-000
Q121	Transistor	461-1050-000
Q122	Transistor	462-1038-200
R101	Res., 1K \pm 2%, 1/4W	434-4101-000
R102	Res., Metal Film, 100K \pm 2%, 1/4W	431-6101-000
R103	Res., 2.2K \pm 5%, 1/4W	434-4222-000
R104	Res., 10K \pm 5%, 1/4W	434-5102-000
R105	Res., 2.7K \pm 5%, 1/4W	434-4272-000
R106	Res., 100K \pm 5%, 1/4W	434-6102-000
R107	Res., 10K \pm 5%, 1/4W	434-5102-000
R108	Res., Var., 2.5K \pm 20%, 1/4W	420-1029-000
R109	Res., 6.8K \pm 5%, 1/4W	434-4682-000
R110	Res., 1K \pm 2%, 1/4W	434-4101-000
R111	Res., 470K \pm 5%, 1/4W	434-6472-000
R112	Res., 15K \pm 5%, 1/4W	434-5152-000
R113	Res., 2K \pm 5%, 1/4W	434-4202-000
R114	Res., 100 Ω \pm 5%, 1/4W	434-3102-000
R115	Res., 820 Ω \pm 5%, 1/4W	434-3822-000
R116	Res., 6.8K \pm 5%, 1/4W	434-4682-000
R117	Res., Metal Film, 1K \pm 1%, 1/4W	439-1017-000
R118	Res., 10K \pm 5%, 1/4W	434-5102-000
R119	Res., 3.3K \pm 5%, 1/4W	434-4332-000
R120	Res., 1K \pm 5%, 1/4W	434-4102-000
R121	Res., Metal Film, 100K \pm 2%, 1/4W	431-6101-000
R122	Res., Metal Film (T9), 20K \pm 2%, 1/2W	432-5201-000
R123	Res., 6.2K \pm 5%, 1/4W	434-4622-000
R124	Res., 1.2K \pm 5%, 1/4W	434-4122-000
R125	Res., 56 Ω \pm 5%, 1/4W	434-2562-000
R126	Res., 510 Ω \pm 5%, 1/4W	434-3512-000
R127	Res., 6.8 Ω \pm 5%, 1/4W	434-1682-000
R128	Res., 6.8 Ω \pm 5%, 1/4W	434-1682-000
R129	Res., 5.6K \pm 5%, 1/4W	434-4562-000

Des.	Description	Part Number
R129	Res., 5.6K \pm 5%, 1/4W	434-4562-000
R130	Res., 330 Ω \pm 5%, 1/4W	434-3332-000
R131	Res., 4.7K \pm 5%, 1/4W	434-4472-000
R132	Res., 47 Ω \pm 5%, 1/4W	434-2472-000
R133	Res., 4.7K \pm 5%, 1/4W	434-4472-000
R134	Res., 330 Ω \pm 5%, 1/4W	434-3332-000
R135	Res., 47 Ω \pm 5%, 1/4W	434-2472-000
R136	Res., Var., 100 Ω \pm 20%, 1/4W	420-1036-000
R137	Res., 22K \pm 5%, 1W	423-5222-000
R138	Res., 1.5K \pm 10%, 5W	428-4152-000
R139	Res., Var., 100 Ω \pm 20%, 1/4W	420-1036-000
R140	Res., 22K \pm 5%, 1W	423-5222-000
R141	Res., 47 Ω \pm 5%, 1/4W	434-2472-000
R142	Res., 330 Ω \pm 5%, 1/4W	434-3332-000
R143	(Not Used)	
R144	Res., 47 Ω \pm 5%, 1/4W	434-2472-000
R145	Res., 47 Ω \pm 5%, 1/4W	434-2472-000
R146	Res., 100K \pm 5%, 1/4W	434-6102-000
R147	(Not Used)	
R148	Res., 47 Ω \pm 5%, 1/4W	434-2472-000
R149	Res., 1.5K \pm 10%, 5W	428-4152-000
R150	Res., 68 Ω \pm 5%, 1/4W	434-2682-000
R151	Res., 1K \pm 5%, 1/4W	434-4102-000
R152	Res., 1K \pm 5%, 1/4W	434-4102-000
R153	Res., 68 Ω \pm 5%, 1/4W	434-2682-000
R154	Res., 30 Ω \pm 5%, 1/4W	434-2302-000
R155	Res., 30 Ω \pm 5%, 1/4W	434-2302-000
R156	Res., 2K \pm 5%, 1/4W	434-4202-000
R157	Res., 1K \pm 5%, 1/4W	434-4102-000
R158	Res., 1K \pm 5%, 1/4W	434-4102-000
R159	Res., 2K \pm 5%, 1/4W	434-4202-000
R160	Res., 820 Ω \pm 5%, 1/4W	434-3822-000
R161	Res., 820 Ω \pm 5%, 1/4W	434-3822-000
R162	Res., 330 Ω \pm 5%, 1/4W	434-3332-000
R163	Res., 820 Ω \pm 5%, 1/4W	434-3822-000
R164	Res., 100K \pm 5%, 1/4W	434-6102-000
R165	Res., 820 Ω \pm 5%, 1/4W	434-3822-000
R166	Res., 330 Ω \pm 5%, 1/4W	434-3332-000
R167	Res., 330 Ω \pm 5%, 1/4W	434-3332-000
R168	Res., 100K \pm 5%, 1/4W	434-6102-000
R169	Res., 8.2K \pm 5%, 1/4W	434-4822-000
R170	Res., 5.6K \pm 5%, 1/4W	434-4562-000
R171	Res., 7.5K \pm 5%, 1/4W	434-4752-000
R172	Res., 7.5K \pm 5%, 1/4W	434-4752-000
R173	Res., 5.6K \pm 5%, 1/4W	434-4562-000
R174	Res., 8.2K \pm 5%, 1/4W	434-4822-000
R175	Res., 10 Ω \pm 5%, 1/2W Compound, Thermal Dissipator, Thermal Insulator, Transistor Mtg Pin, Connector Retainer, Thermal	433-2102-000 637-1001-000 562-1006-000 372-1000-000 360-1025-000 562-1005-000



For applicable dash number, see Transistor Specification Chart on unit Schematic (Figure 18)

POWER AMPLIFIER BOARD PARTS LIST

Des.	Description	Part Number
A2	Power Amplifier Board Assembly	200-1057-100
C201	Cap., 0.22 μ fd \pm 10%, 250V	386-1001-000
C202	Cap., Elect., 18 μ fd, 100V	381-1066-000
C203	Cap., Elect., 18 μ fd, 100V	381-1066-000
C204	Cap., 0.047 μ fd \pm 10%, 250V	386-1011-000
C205	Cap., 27 pfd \pm 10%, 100V	385-1036-000
C206	Cap., 27 pfd \pm 10%, 100V	385-1036-000
C207	Cap., 270 pfd \pm 10%, 300V	385-1090-000
C208	Cap., 0.01 μ fd \pm 10%, 100V	385-1032-000
C209	Cap., 0.01 μ fd \pm 10%, 100V	385-1032-000
C210	Cap., 270 pfd \pm 10%, 300V	385-1090-000
C211	Cap., 0.1 μ fd \pm 10%, 250V	386-1000-000
C212	Cap., 0.068 μ fd \pm 10%, 250V	386-1020-000
C213	Cap., 0.22 μ fd \pm 10%, 250V	386-1001-000
C214	Cap., 0.1 μ fd \pm 10%, 250V	386-1000-000
CR201	Diode, 13V Zener	459-1004-000
CR202	Diode, 13V Zener	459-1004-000
CR203	(Not Used)	
CR204	(Not Used)	
CR205	Diode, 200 PIV	460-1019-000
CR206	Diode, 200 PIV	460-1019-000
L201	Toroid	147-1008-000
Q201	Transistor (with Mica Insulator)	462-1057-000
Q202	Transistor	462-1058-000
Q203	Transistor	461-1050-000
R201	Res., 300 Ω \pm 5%, 1/2W	433-3302-000
R202	Res., 1/2W (Selected Value)	
R203	Res., 43K \pm 5%, 1/2W	433-5432-000
R204	Res., 200 Ω \pm 5%, 1/2W	433-3202-000
R205	Res., 200 Ω \pm 5%, 1/2W	433-3202-000
R206	Res., 2.7 Ω \pm 5%, 1/2W	433-1272-000
R207	Res., 10 Ω \pm 5%, 1/2W	433-2102-000
R208	Res., 4.3K \pm 5%, 1/2W	433-4432-000
R209	Res., Var. 5K \pm 30%, 2W	420-1042-000
R210	Res., 200 Ω \pm 5%, 1/2W	433-3202-000
R211	Res., 200K \pm 5%, 1/2W	433-6202-000
R212	Res., 200 Ω \pm 5%, 1/2W	433-3202-000
R213	Res., Var., 5K \pm 30%, 2W	420-1042-000
R214	Res., 180K \pm 5%, 1/2W	433-6182-000
R215	Res., 3.9K \pm 5%, 1/2W	433-4392-000
R216	Res., 39K \pm 5%, 1/2W	433-5392-000
R217	Res., 10 Ω \pm 5%, 1/2W	433-2102-000
R218	Res., 20 Ω \pm 5%, 2W	424-2202-000

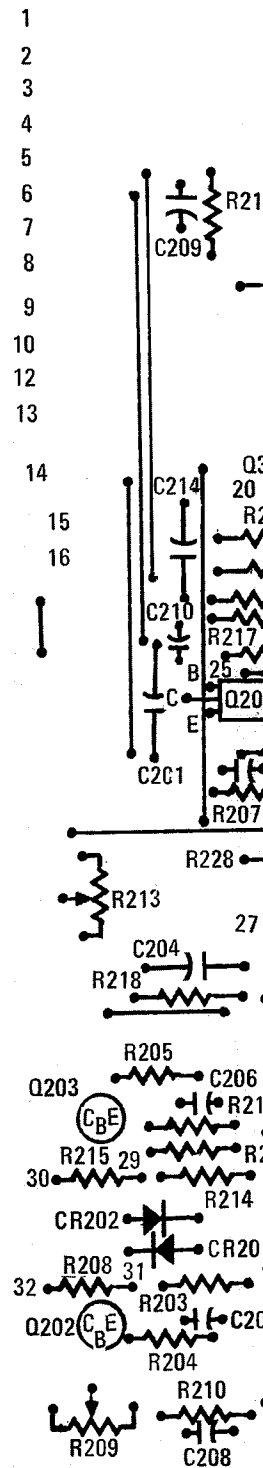
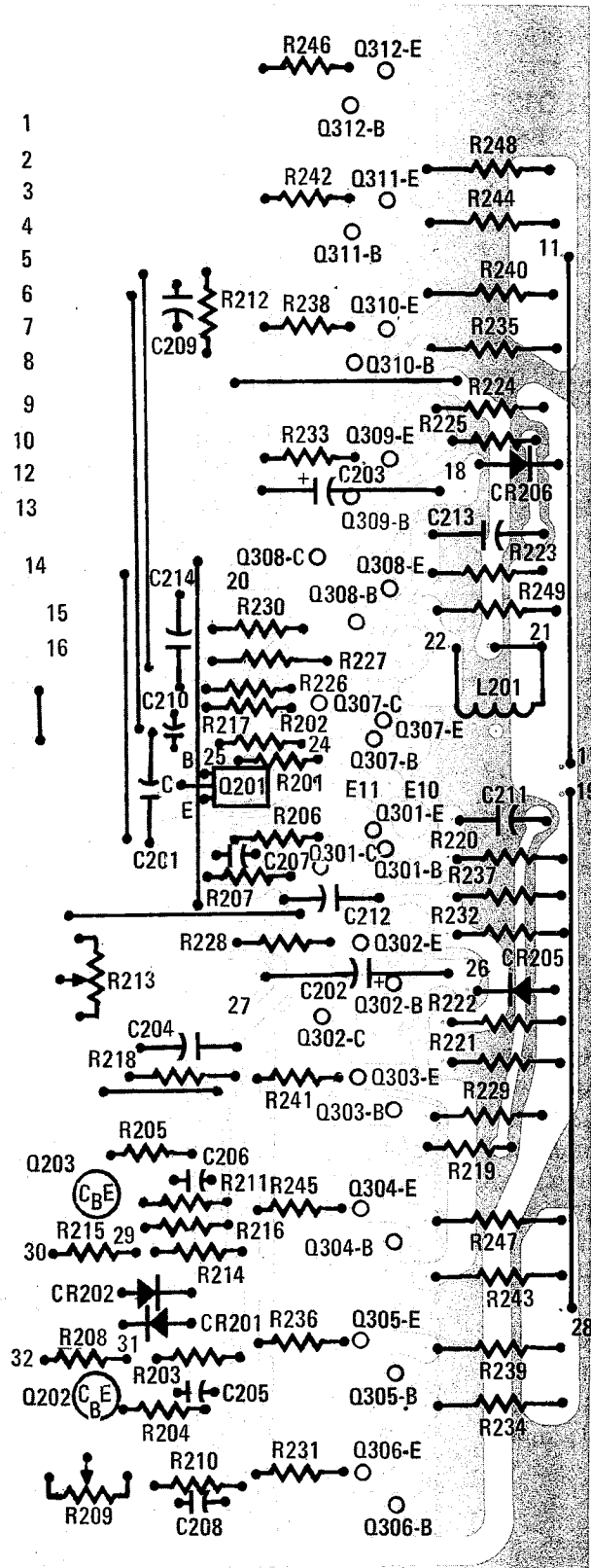



Figure 15. Power Amplifier Board Assembly (A2) (Cont.)

Parts List



Circuit Side

Figure 15. Power Amplifier Board Assembly (A2) (Cont.)

Q201 Located on opposite side of board. 

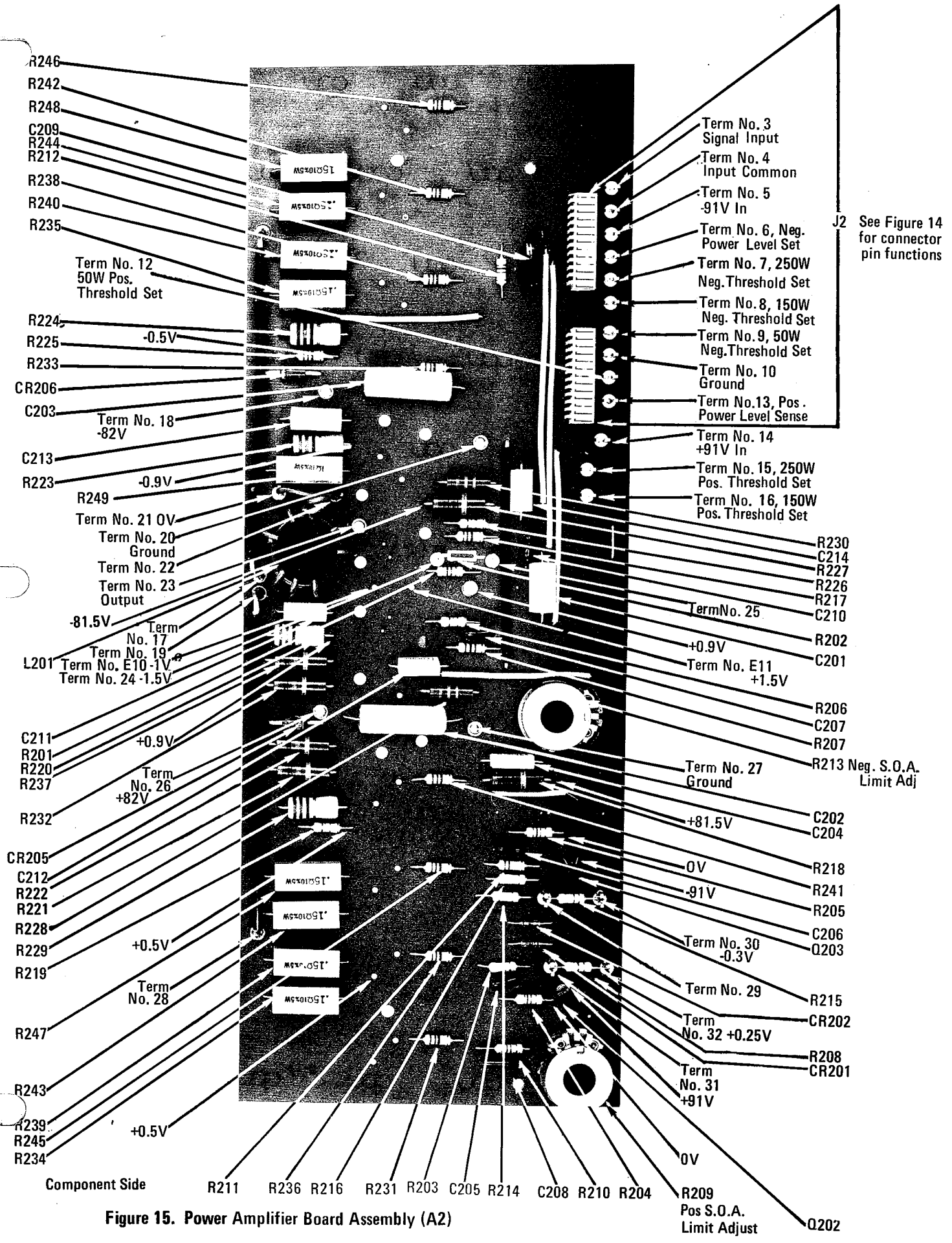

Figure 15. Power Amplifier Board Assembly (A2)

POWER AMPLIFIER BOARD PARTS LIST (Cont.)

Des.	Description	Part Number
R219	Res., $2.7\Omega \pm 5\%$, 1/2W	433-1272-000
R220	Res., $27\Omega \pm 5\%$, 2W	439-1021-000
R221	Res., $100\Omega \pm 5\%$, 2W	424-3102-000
R222	Res., $100\Omega \pm 5\%$, 2W	424-3102-000
R223	Res., $27\Omega \pm 5\%$, 2W	439-1021-000
R224	Res., $12\Omega \pm 5\%$, 2W	439-1019-000
R225	Res., $10\Omega \pm 5\%$, 1/2W	433-2102-000
R226	Res., $2.7\Omega \pm 5\%$, 1/2W	433-1272-000
R227	Res., $20\Omega \pm 5\%$, 2W	424-2202-000
R228	Res., $2.7\Omega \pm 5\%$, 1W	423-1272-000
R229	Res., $12\Omega \pm 5\%$, 2W	439-1019-000
R230	Res., $2.7\Omega \pm 5\%$, 1W	423-1272-000
R231	Res., $10\Omega \pm 5\%$, 1/2W	433-2102-000
R232	Res., $100\Omega \pm 5\%$, 2W	424-3102-000
R233	Res., $10\Omega \pm 5\%$, 1/2W	433-2102-000
R234	Res., $0.15\Omega \pm 10\%$, 5W	428-0153-000
R235	Res., $0.15\Omega \pm 10\%$, 5W	428-0153-000
R236	Res., $10\Omega \pm 5\%$, 1/2W	433-2102-000
R237	Res., $100\Omega \pm 5\%$, 2W	424-3102-000
R238	Res., $10\Omega \pm 5\%$, 1/2W	433-2102-000
R239	Res., $0.15\Omega \pm 10\%$, 5W	428-0153-000
R240	Res., $0.15\Omega \pm 10\%$, 5W	428-0153-000
R241	Res., $10\Omega \pm 5\%$, 1/2W	433-2102-000
R242	Res., $10\Omega \pm 5\%$, 1/2W	433-2102-000
R243	Res., $0.15\Omega \pm 10\%$, 5W	428-0153-000
R244	Res., $0.15\Omega \pm 10\%$, 5W	428-0153-000
R245	Res., $10\Omega \pm 5\%$, 1/2W	433-2102-000
R246	Res., $10\Omega \pm 5\%$, 1/2W	433-2102-000
R247	Res., $0.15\Omega \pm 10\%$, 5W	428-0153-000
R248	Res., $0.15\Omega \pm 10\%$, 5W	428-0153-000
R249	Res., $1\Omega \pm 10\%$, 5W	428-1103-000
	Compound, Thermal	637-1002-000
	Connector, Female, 13 Pin	360-1020-000
	Retainer, Toroid	570-1003-000
	Screw, #4-40 x 3/8, Cad	721-0610-000
	Screw, #6-32 x 5/8, Blk	741-1012-000
	Socket, Transistor Pin (TO-3)	368-1006-000
	Socket, Transistor Pin (TO-66)	368-1005-000
	Spacer, #4-40	168-1011-000
	Washer, Lock, #4, Cad	671-2230-000

Notes:

1. Voltages are d.c. volts to ground measured on a typical unit.
2. Configuration shown is applicable to circuit boards fabricated from A/W 115-1057, Rev. A.
3. Apply a liberal amount of P/N 637-1002-000 Thermal Compound to both sides of mica insulator associated with Q201.

MODEL 500

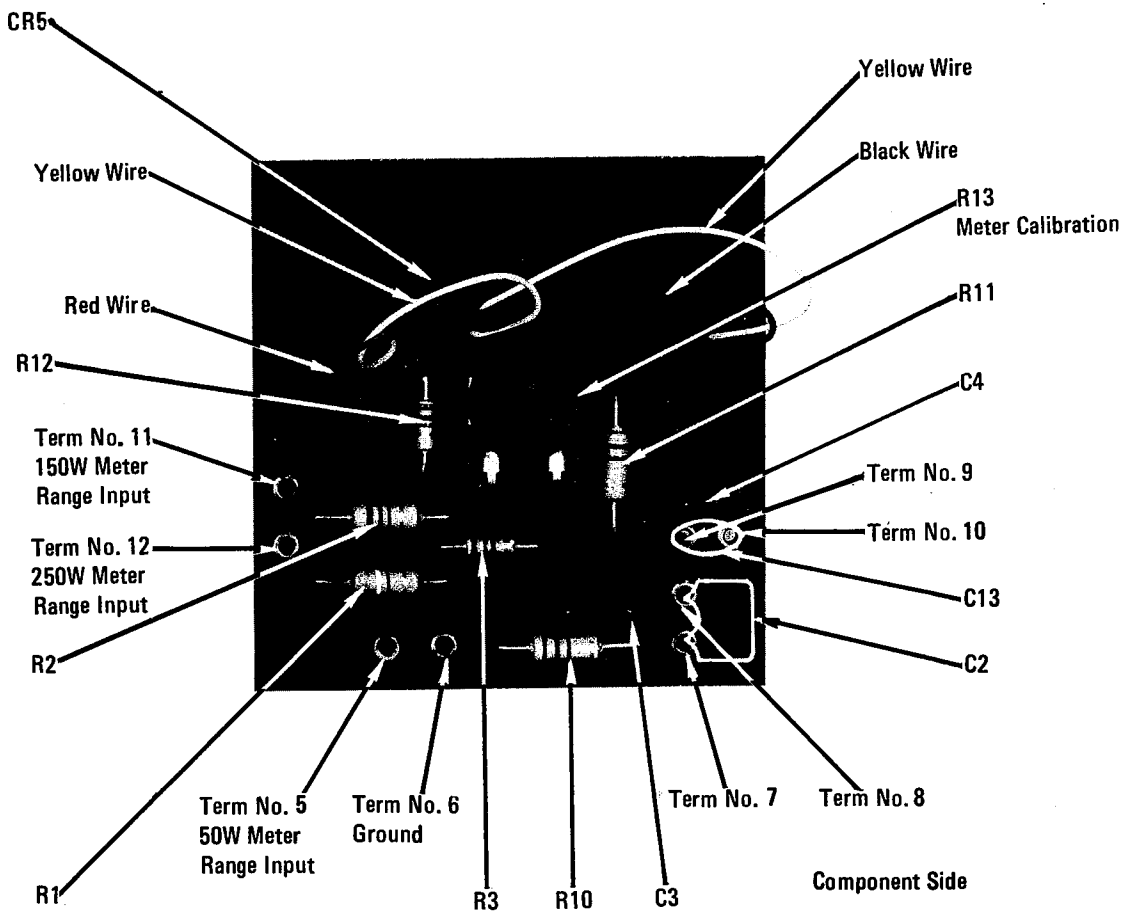

Figure 16. Meter Board Assembly (A3)

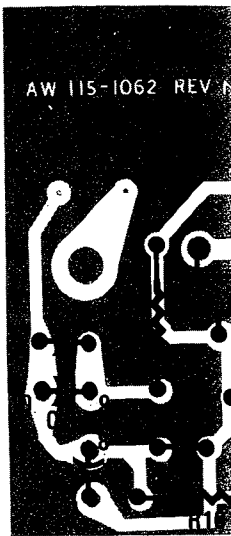

Figure 16. Meter Board

METER BOARD PARTS LIST

Des.	Description	Part Number
A3	Meter Board Assembly	200-1062-100
C2	Cap., 100V (Selected Value)	
C3	Cap., 680 pfd ±10%, 100V	385-1042-000
C4	Cap., 360 pfd ±10%, 100V	385-1075-000
C13	Cap., 100V (Selected Value)	
CR5	Rectifier Bridge	468-1002-000
R1	Res., 3.9K ±5%, 1/2W	433-4392-000
R2	Res., 5.6K ±5%, 1/2W	433-4562-000
R3	Res., 6.8K ±5%, 1/4W	434-4682-000
R10	Res., 5.1K ±5%, 1/2W	433-4512-000
R11	Res., 110K ±5%, 1/2W	433-6112-000
R12	Res., 1K ±5%, 1/4W	434-4102-000
R13	Res., Var., 5K ±20%, 1/4W	420-1035-000
	Screw, #4-40 x 3/16, Blk	721-0310-000

Notes:

1. Configuration shown is as boards fabricated from Rev. N/C.

115-1062 REV N/C



Circuit Side

Meter Board Assembly (A3) (Cont.)

shown is applicable to circuit
 ted from A/W 115-1062,

RECTIFIER/RELAY BOARD PARTS LIST

Des.	Description	Part Number
A4	Rectifier/Relay Board Assembly	200-1019-100
C401	Cap., Elect., 8000 μ fd, 15V	381-1064-000
C402	Cap., Elect., 8000 μ fd, 15V	381-1064-000
C403	Cap., Elect. 18 μ fd, 100V	381-1066-000
C404	Cap., Elect., 18 μ fd, 100V	381-1066-000
C405	Cap., Elect., 150 μ fd, 25V	381-1080-000
C406	Cap., Elect., 33 mfd, 16V	381-1035-100
C407	Cap., Elect., 33 mfd, 16V	381-1035-100
C408	Cap., Elect., 150 mfd, 25V	381-1080-000
CR401 thru CR406	Diode, Rectifier	460-1006-000
K401	Relay, DPDT	410-1000-000
K402	Relay, DPDT	410-1000-000
Q401	Transistor	462-1053-000
Q402	Transistor	462-1053-000
Q403 thru Q406	Transistor	462-1058-000
R401	Res., 1K \pm 5%, 1/2W	433-4102-000
R402	Res., 1K \pm 5%, 1/2W	433-4102-000
R403	Res., 39K \pm 5%, 1/2W	433-5392-000
R404	Res., 4.3K \pm 5%, 1/2W	433-4432-000
R405	Res., 62K \pm 5%, 1/2W	433-5622-000
R406	Res., 4.3K \pm 5%, 1/2W	433-4432-000
R407	Res., 62K \pm 5%, 1/2W	433-5622-000
R408	Res., 39K \pm 5%, 1/2W	433-5392-000
R409	Res., 1K \pm 5%, 5W	428-4102-000
R410	Res., 1.5M \pm 5%, 1/2W	433-7152-000
R411	Res., 220K \pm 5%, 1/2W	433-6222-000
R412	Res., 220K \pm 5%, 1/2W	433-6222-000
R413	Res., 1.5M \pm 5%, 1/2W	433-7152-000
R414	Res., 1K \pm 5%, 5W	428-4102-000
R415	Res., 5.6K \pm 5%, 1/2W	433-4562-000
R416	Res., 5.6K \pm 5%, 1/2W	433-4562-000
R417	Res., 3K \pm 10%, 5W	428-4303-000
R418	Res., 3K \pm 10%, 5W	428-4303-000
	Bracket	132-1036-000
	Clamp, Capacitor	561-1006-000
	Insulator, Transistor Mtg	372-1000-000
	Rivet, 1/8 Dia x 5/32 Lg	655-4056-000
	Rivet, 1/8 Dia x 3/16 Lg	655-4066-000
	Rivet, 1/8 Dia x 7/32 Lg	655-4076-000
	Washer, Shoulder	677-1004-000

Q201 Located on opposite side of board. 

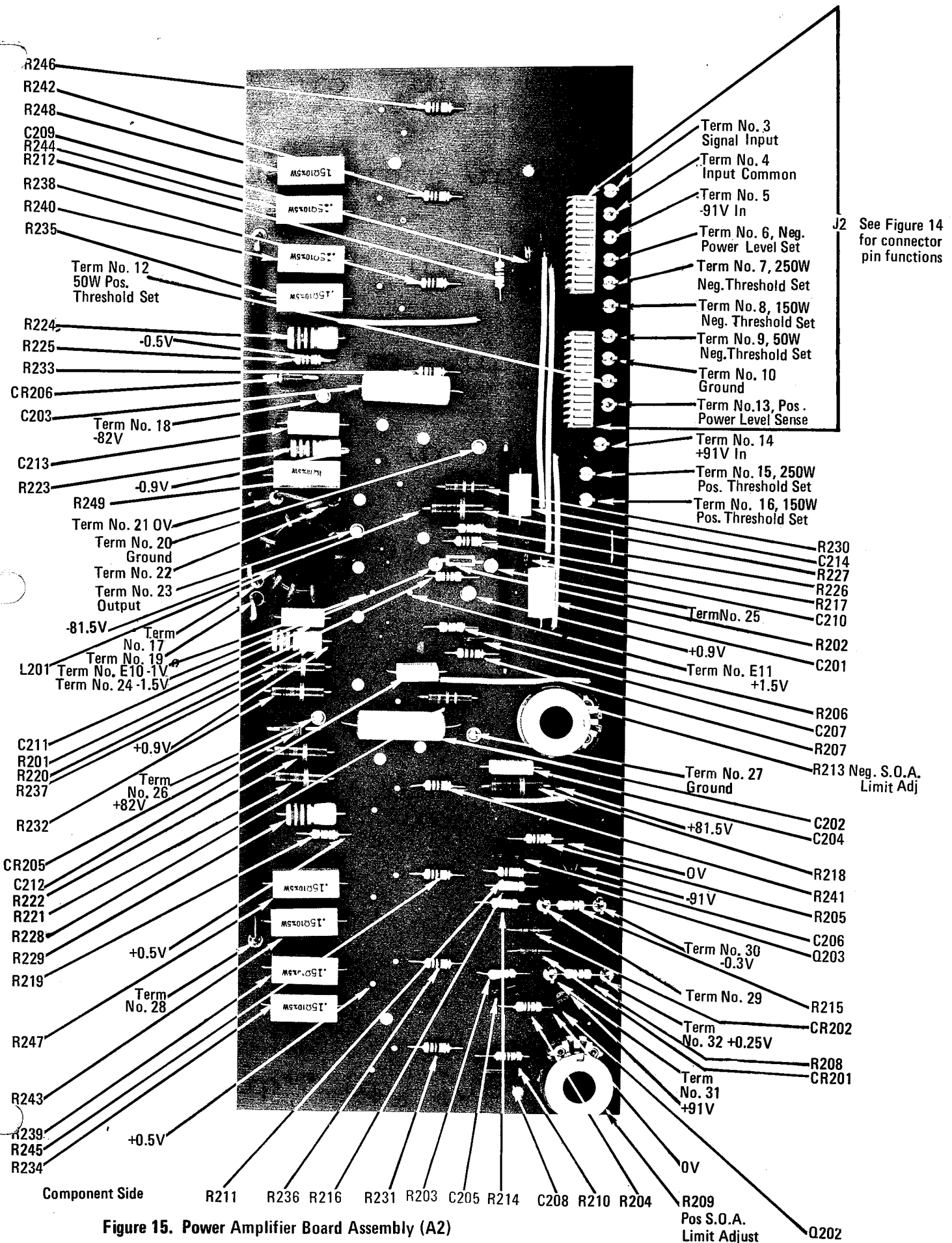

Figure 15. Power Amplifier Board Assembly (A2)

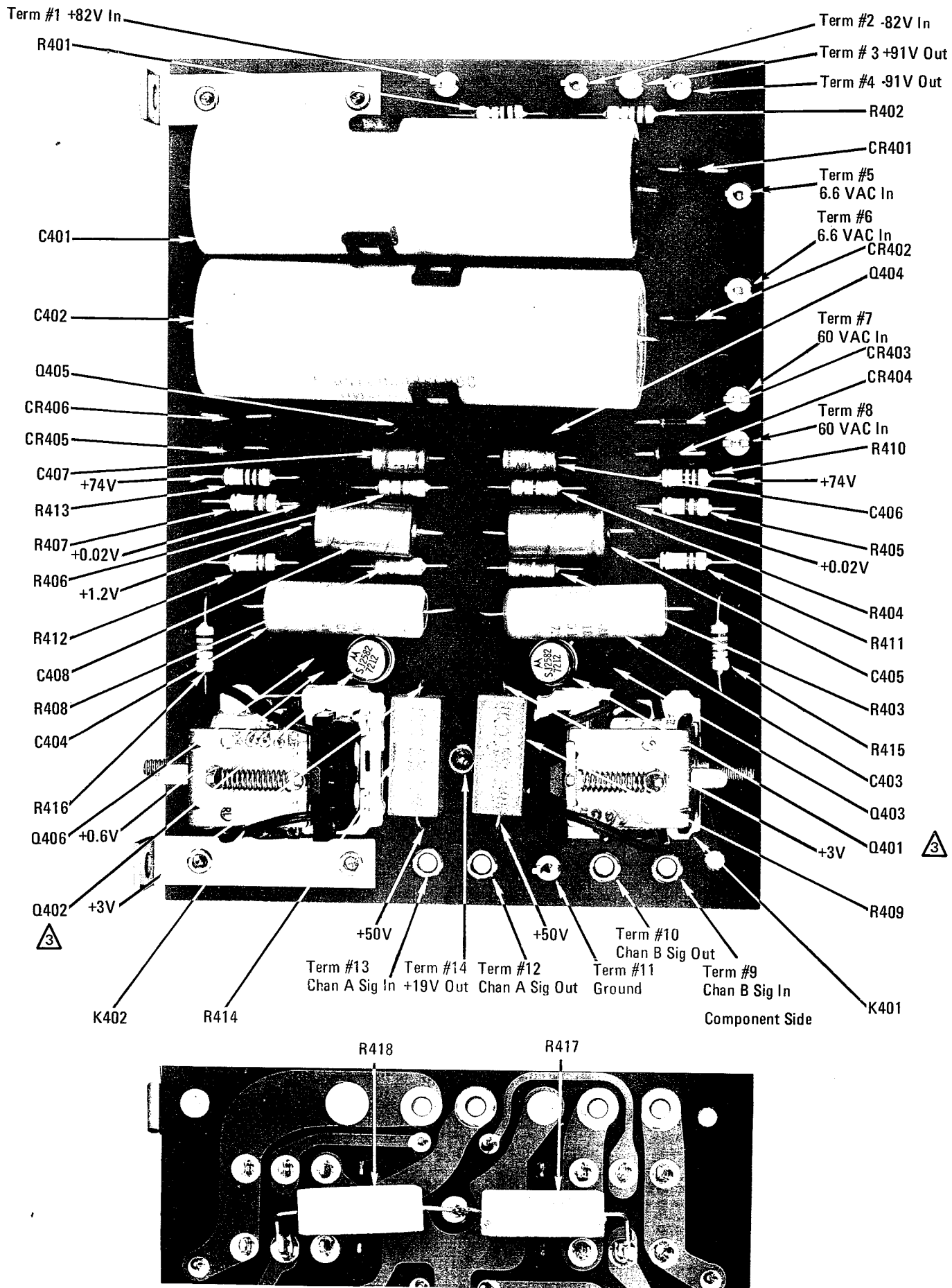
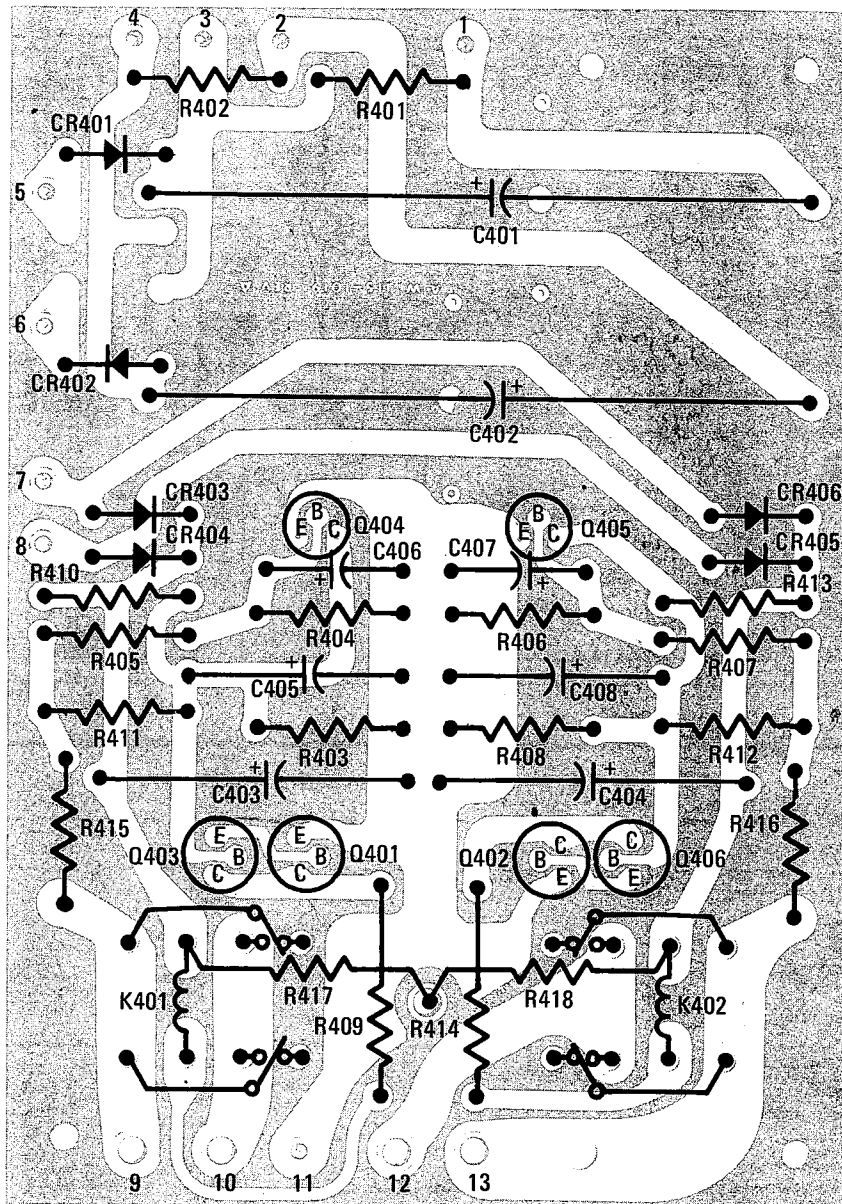



Figure 17. Rectifier/Relay Board Assembly (A4)



Circuit Side

Notes:

1. Voltages are d.c. volts to ground (unless otherwise specified), measured on a typical unit.
2. Configuration shown is applicable to circuit boards fabricated from A/W 115-1019, Rev. A.
3.  P/N 372-1000-000 Insulator to be installed beneath Q401 and Q402.

DASH NUMBER
-1
-2
-3
-4
-1
-2
-3
-4

Figure 17. Rectifier/Relay Board Assembly (A4) (Cont.)

MODEL 500

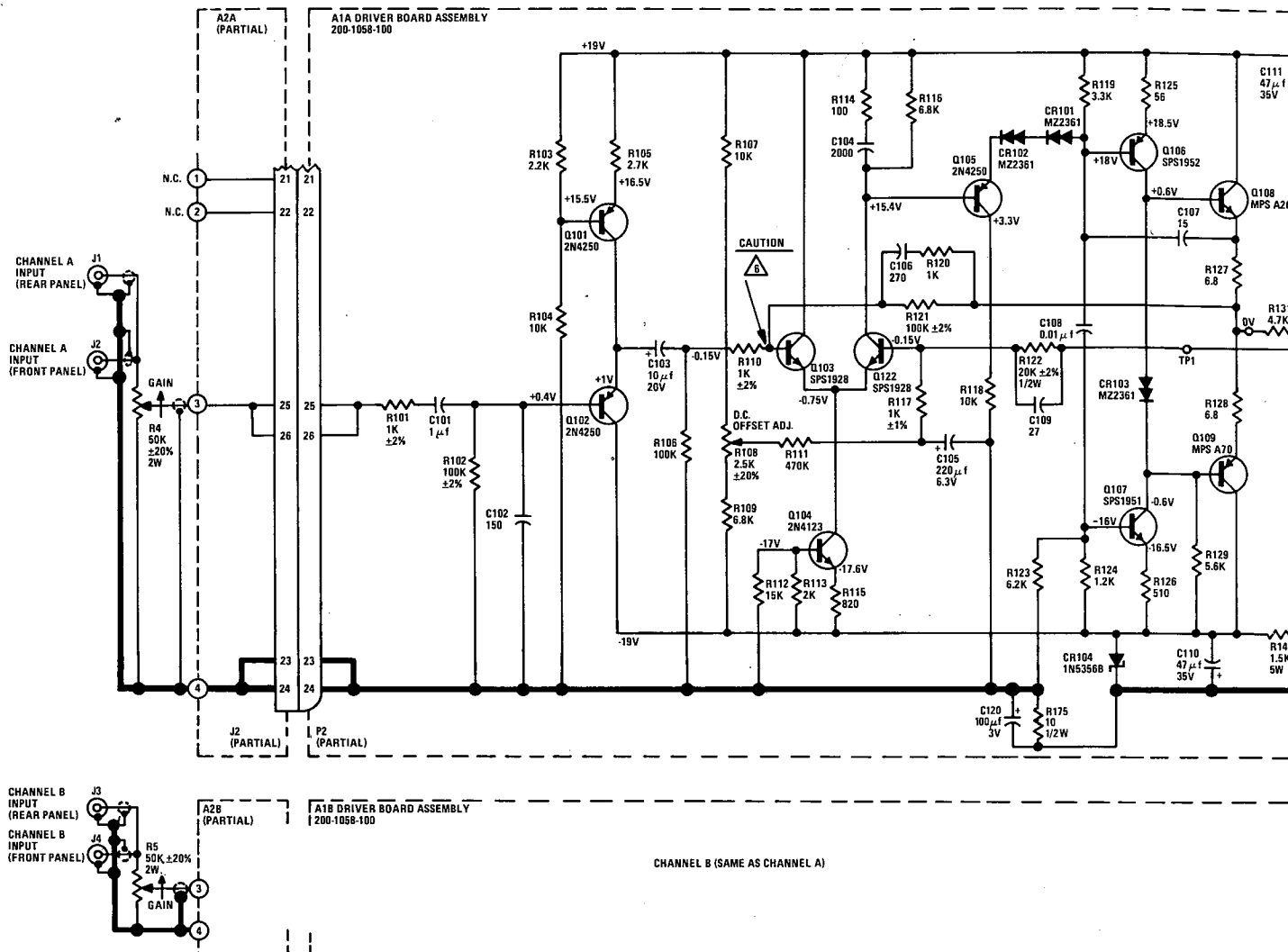

- 14. ALL TRANSISTORS IN GROUP Q303 THRU Q306 AND Q309 THRU Q312 TO BE IN SAME BETA GROUP PER BETA RANGE CHART.
 - 13. TRANSISTORS IN PAIRS Q301-Q307 AND Q302-Q308 ARE TO BE IN THE SAME BETA GROUP PER BETA RANGE CHART.
 - 12. TRANSISTORS IN PAIR Q117-Q118 ARE TO BE IN THE SAME BETA GROUP USING -2, -3, OR -4 PARTS ONLY PER BETA RANGE CHART.
 - 11. TRANSISTORS IN PAIRS Q110-Q111 AND Q112-Q113 ARE TO BE IN THE SAME BETA GROUP USING ONLY -1 OR -4 PARTS PER BETA RANGE CHART.
 - 10. (NOT USED)
 - 9. (NOT USED)
 - 8. S2 AND S3 ARE SHOWN IN 50/100 POSITION (MAX CCW).
 - 7. VOLTAGES ARE TAKEN WITH NO SIGNAL APPLIED.
 - 6. CAUTION: DO NOT MEASURE - TEST LEAD MAY CAUSE OSCILLATION.
 - 5. COMPONENT TO BE OF SELECTED VALUE, IF REQUIRED BY TEST.
 - 4. PART OF 230-1025-100, HEAT SINK ASSEMBLY.
 - 3. ALL CAPACITORS ARE IN μf , 100V. TOLERANCE ON NON-ELECTROLYTIC TYPES = $\pm 10\%$.
 - 2. ALL RESISTORS ARE IN OHMS, $\pm 5\%$, 1/2W, FOR 200 AND 400 SERIES.
 - 1. ALL RESISTORS ARE IN OHMS, $\pm 5\%$, 1/4W (EXCEPT 200 AND 400 SERIES).
- NOTES: UNLESS OTHERWISE SPECIFIED.

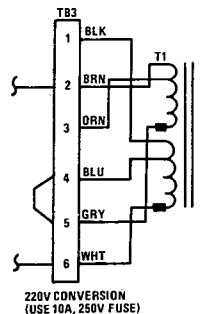
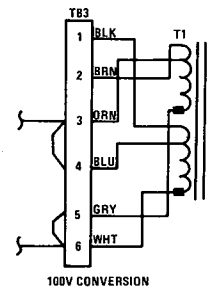
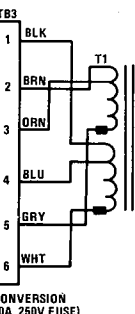
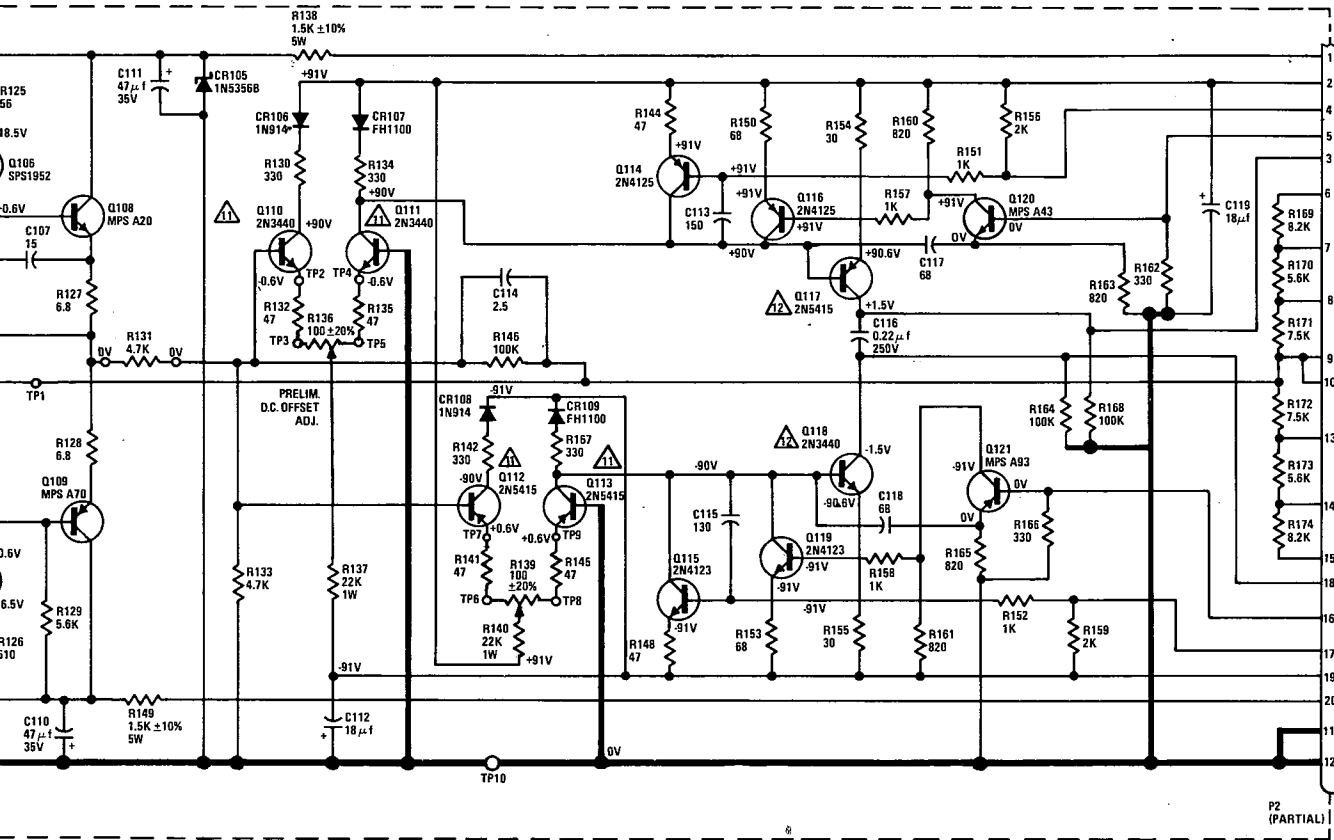

Figure 18A. Model 500 Schematic



BETA RANGE CHART 13 14				
REF DESIG	TYPE	BETA RANGE h_{fe}	COLOR CODE	DASH NUMBER
Q301	SJ2504 (462-1025)	40-75	RED	-1
		76-100	YELLOW	-2
		101 & UP	GREEN	-3
Q302	SJ2503 (461-1018)	50-100	ORANGE	-1
		101-200	GREEN	-2
		201 & UP	GRAY	-3
Q303	SJ2500 (462-1023)	30-49	RED	-1
		50-69	ORANGE	-2
		70-99	YELLOW	-3
		100 & UP	GREEN	-4
Q307	SJ2505 (461-1019)	40-75	RED	-1
		76-100	YELLOW	-2
		101 & UP	GREEN	-3
Q308	SJ2502 (462-1024)	50-100	ORANGE	-1
		101-200	GREEN	-2
		201 & UP	GRAY	-3
Q309	SJ2501 (461-1017)	30-49	RED	-1
		50-69	ORANGE	-2
		70-99	YELLOW	-3
		100 & UP	GREEN	-4

2SD555

2SB600

BETA RANGE CHART 11 12				
REF DESIG	TYPE	BETA RANGE h_{fe}	COLOR CODE	DASH NUMBER
Q110	2N3440 (462-1056)	40-49	RED	-1
		50-74	ORANGE	-2
		75-99	YELLOW	-3
		100-160	GREEN	-4
Q112	2N5415 (461-1049)	30-49	RED	-1
		50-74	ORANGE	-2
		75-99	YELLOW	-3
Q117		100-150	GREEN	-4

MODEL 500

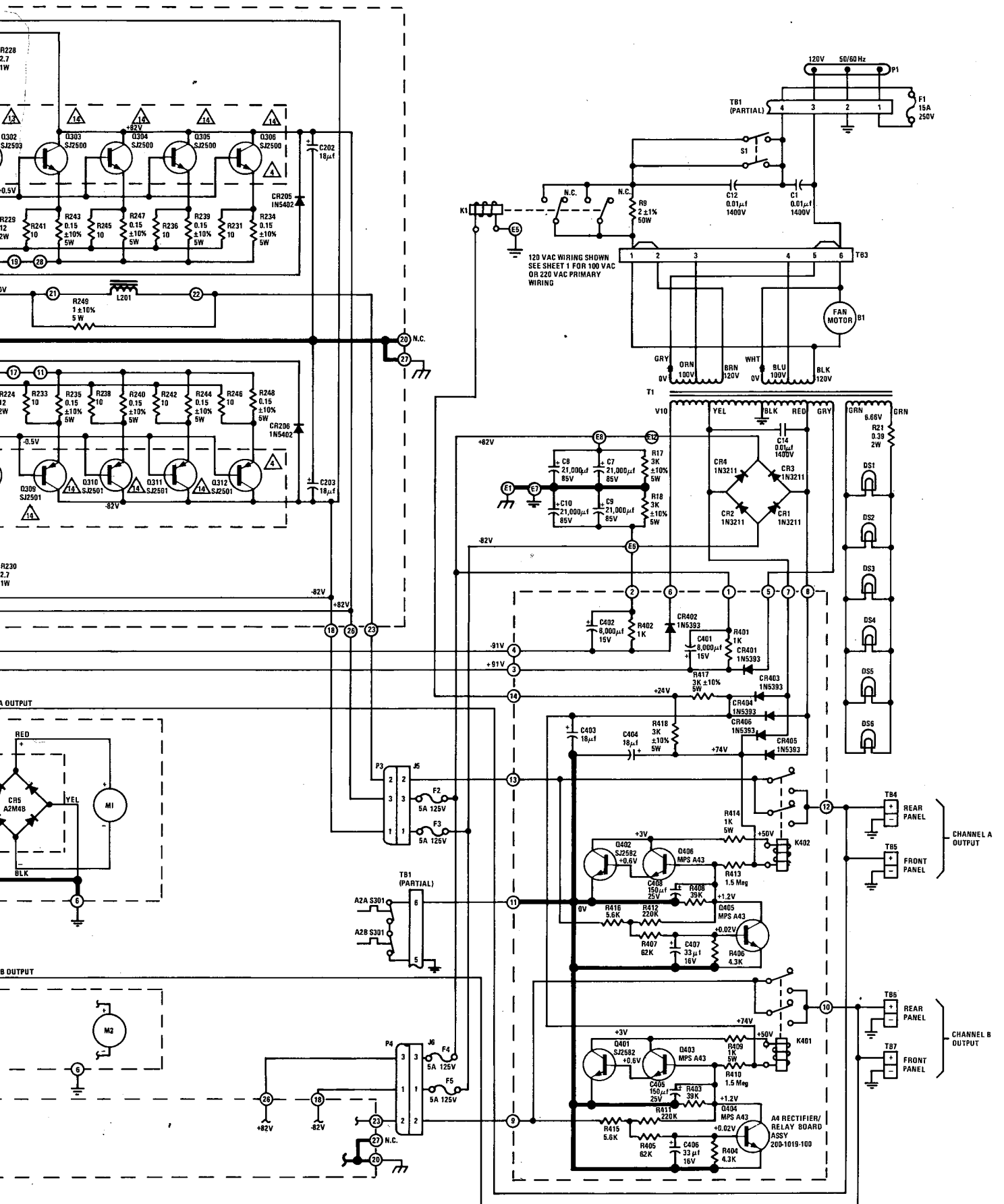

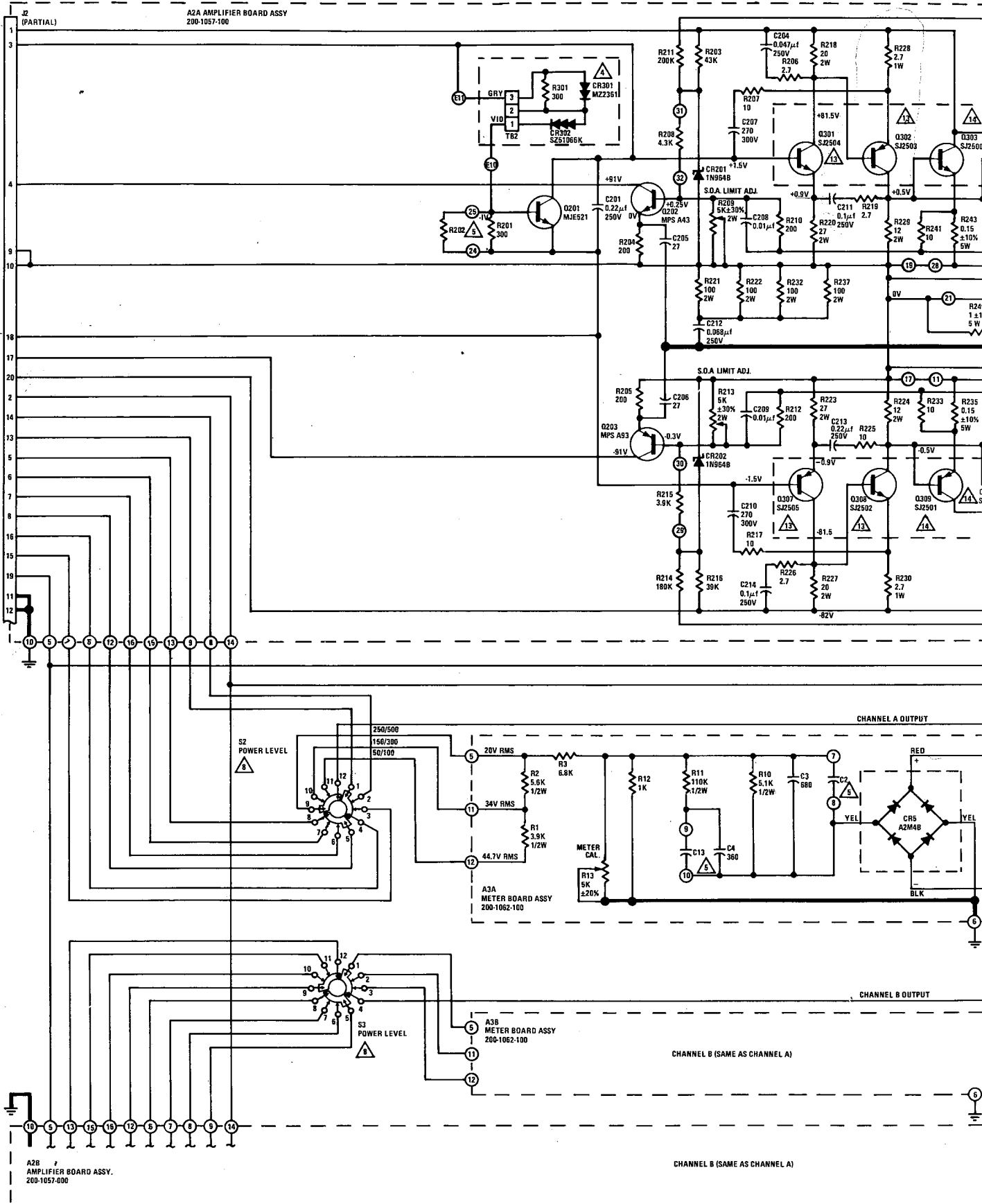

Figure 18B. Model 500 Schematic (Cont.)



marantz

MARANTZ CO., INC. · P.O. BOX 99 · SUN VALLEY, CALIFORNIA · 91352
A WHOLLY OWNED SUBSIDIARY OF SUPERSCOPE INC., SUN VALLEY, CALIFORNIA 91352