

**SERVICE
MANUAL 6270Q**

marantz

model 6270Q

Turntable

MARANTZ DESIGN AND SERVICE

Using superior design and selected high grade components, MARANTZ Company has created the ultimate in stereo sound. Only original MARANTZ parts can insure that your MARANTZ product will continue to perform to the specifications for which it is famous.

Parts for your MARANTZ stereo are generally available within 72 hours throughout the nation via a toll-free line to our National Parts Depot in California. The sales professionals who take your call immediately refer to their own desk top computer terminal and can quickly determine the availability and price information you require. If for some reason, your order should exceed our available stock, we usually can instantly provide an alternate replacement part or current delivery information. When the order is placed and confirmed, the computer simultaneously generates "hard copy" orders at the distribution center. As hard copies come directly from the computer to the national parts depot, your requested stock is assembled and prepared for shipment and placed on the first available carrier for delivery to you.

ORDERING PARTS

Phone orders will eliminate mail delays, and we encourage the use of this method. If you order by mail, use MARANTZ parts order forms which are available from our National Parts Depot located at the following address:

SUPERSCOPE NATIONAL PARTS DEPARTMENT
20525 Nordhoff Street
Chatsworth, California 91311
Phone: 1-800-423-5108
1-213-998-9333

The following information must be supplied to eliminate delays in processing your order:

1. Complete address.
2. Complete part numbers.
3. Complete description of parts.
4. Model number for which part is required (indicate MARANTZ).
5. Account number (for account customers only).

Direct consumers will be provided with the current retail price quotation on available parts in order to advise them of the cost of the parts and shipping.

OVERSEAS PARTS ORDERING

Parts may also be ordered from the following overseas addresses:

CANADA

Superscope Canada, Ltd.
3710 Nashua Drive
Mississauga
Ontario, Canada L4V1M5

AUSTRALIA

Superscope (Australasia) Pty., Ltd.
32 Cross Street (P.O. Box 604)
Brookvale 2100 N.S.W.
Australia

JAPAN

Marantz Japan, Inc.
3622 Kamitsuruma
Sagamihara Shi
Kanagawa, Japan

EUROPE

Superscope Europe, S.A.
Avenue Leopold III, 2
7120 Peronnes-Lez-Binche
Belgium

Marantz France
Rue Louis Armand 9
92600 Asnieres
Hauts-de-Seine
France

Marantz Audio U.K. Ltd.
London Road, 203
Staines
Middlesex
England

Superscope GmbH
Max-Planck-Strasse 22
D-6072 Dreieich 1
West Germany

All of the above locations are fully equipped to take care of your total service needs. Because various countries have differing configuration requirements, it is necessary that you contact the service facility in your particular country. In the event that there is no service location listed for your country, please contact the nearest facility for the necessary assistance.

marantz
We sound better.

TABLE OF CONTENTS

SECTION	PAGE
1 MECHANICAL OPERATION	2
1.1 Auto Mode	2
1.2 Manual Mode	2
2 ADJUSTMENTS	3
2.1 Tone Arm Adjustment	3
2.2 Check and Adjustment Procedure of M6270Q Motor Drive PWB	4
3 SERVICE NOTES	5
3.1 Voltage Conversion for European Model	5
3.2 Cartridge Wire Color Code	5
3.3 Replacement Parts/Technical Assistance	5
4 DIAGRAM AND COMPONENT LOCATIONS	6
4.1 Switch Assembly (PS01) Schematic Diagram and Component Locations	6
4.2 Led. Swtich Assembly (PT01) Schematic Diagram and Component Locations	6
4.3 Led. Switch Assembly (PT02) Schematic Diagram and Component Locations	6
4.4 Power Supply Assembly (P800) Schematic Diagram and Component Locations	6
4.5 Led. Assembly (PY00) Schematic Diagram and Component Locations	7
4.6 Connective Assembly (PV03) Schematic Diagram and Component Locations	7
5 SCHEMATIC DIAGRAM	8
6 EXPLOCED VIEW AND PARTS LIST	10
7 ELECTRICAL PARTS LIST	16
8 TECHNICAL SPECIFICATIONA	17

MARANTZ MODEL 6270Q TURNTABLE

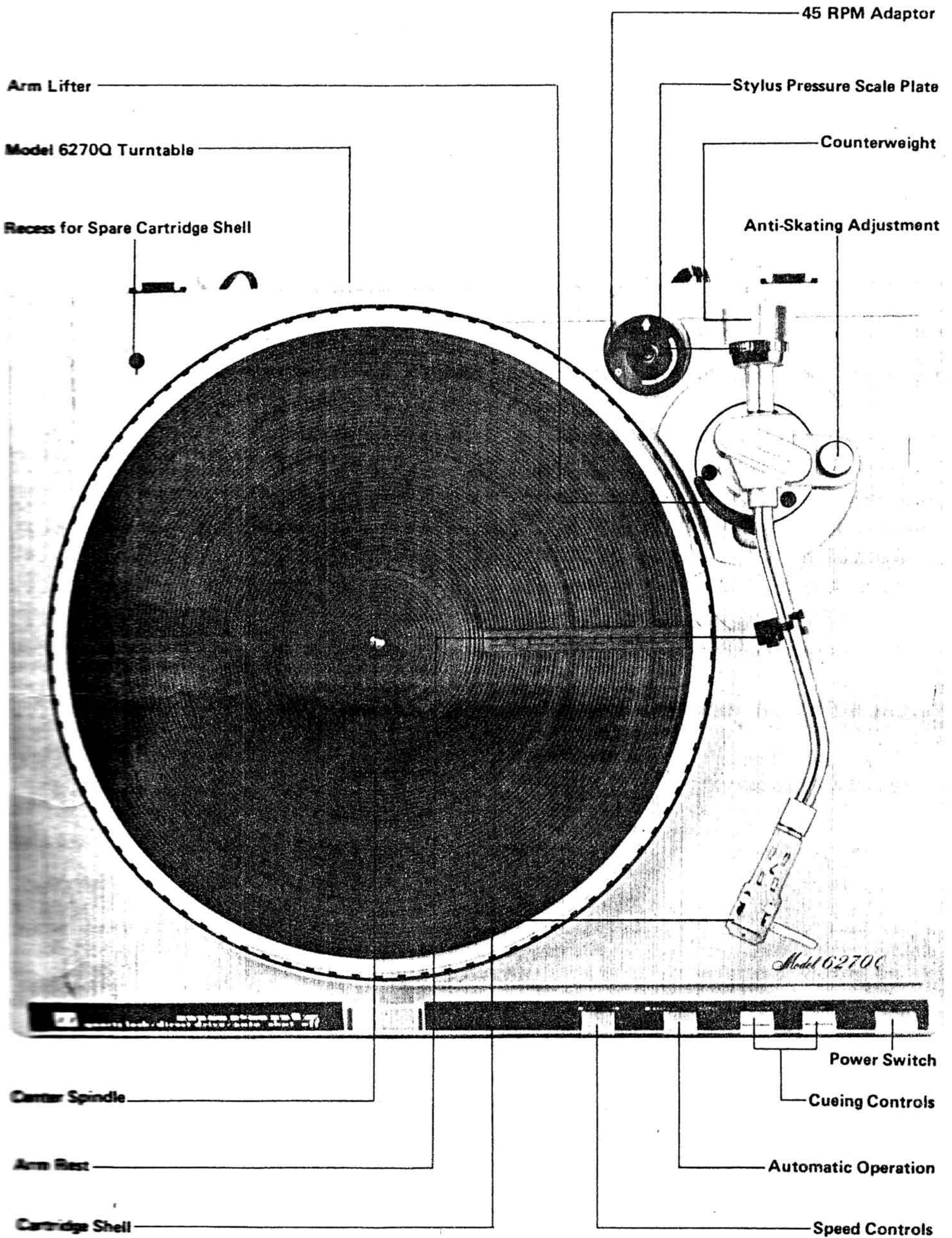

1. MECHANICAL OPERATION

1.1 Auto Mode

When in the AUTO mode the tone arm will lift up and the turntable will stop automatically when the record has finished playing. Operation is as follows:

1. Depress the **AUTO/MANUAL** pushswitch.
2. Depress the **POWER** switch. The turntable will not rotate yet.
3. Position the stylus over the first groove of the record.
4. Press the **CUE DOWN** button. Now the turntable will start, and the arm will slowly descend. By the time the stylus contacts the disc, the turntable will be up to speed.
5. When the record finishes playing, the arm will lift and the turntable will stop.
6. To lift the arm and stop the turntable before the end of the record, press the **CUE UP** pushbutton.

1.2 Manual Mode

1. Turn on your amplifier system and select the Model 6270Q Turntable as the source input.
2. Place a record on the turntable. For a 45 RPM record, fit the supplied adaptor over the turntable center spindle.
3. Press the **CUE UP** button.
4. Select the desired speed (33 or 45).
5. Place the turntable in MANUAL mode (pushswitch released).
6. Depress the **POWER** switch. The turntable will rotate. While the record is turning, you may wish to clean its surface with a suitable cleaning device before playing.
7. Take the arm out of the arm rest and position the stylus directly above the desired groove.
8. Press the **CUE DOWN** button. The stylus will slowly descend to the selected groove. A small amount of practice will enable precise record cueing.
9. To lift the tone arm at any time, press the **CUE UP** pushbutton.
10. To stop the turntable, press and release the **POWER** pushswitch.

If you wish to clean the record as it rotates on the turntable, leave the arm on the arm rest and press the **CUE DOWN** pushbutton (press the **CUE UP** pushbutton after cleaning to avoid stylus damage due to hand lowering), or temporarily put the turntable in the MANUAL mode.

2. ADJUSTMENTS

2.1 TONE ARM ADJUSTMENTS

● STYLUS TRACKING ANGLE

When setting up the arm for playing, it is important to check the tracking angle, because improper tracking angle will cause distortion and premature record wear. Most phono cartridges are designed so that when the cartridge is mounted on a surface parallel with the record surface, the stylus will track at the proper angle (see Figure 4). The surface inside of the cartridge shell (against which the cartridge is mounted) is parallel to the record surface when the stylus is touching the record surface. Visually check the angle of the tone arm in actual playing position. If it is not level and parallel with the record surface, then it is necessary to change the height of the tone arm by using the spacers supplied with the phono cartridge. This, of course, requires removing and remounting the cartridge, and some trial and error technique. With most cartridges, no spacers will be necessary.

NOTE

Some cartridges are built so that their bodies are at an angle with respect to their own mounting tabs. No attempt should be made to change this angle. Simply make sure that the cartridge mounting tab surfaces are parallel to the tone arm shell mounting surface before proceeding with the stylus overhang adjustments.

● STYLUS OVERHANG

The model 6270Q Turntable is designed to operate with the least distortion when the tip of the stylus is at a particular distance from the tone arm pivot. For this reason, the cartridge shell is slotted, allowing the cartridge with its mounting screws to be slid toward or away from

the pivot point. This, in effect, changes the radius of the arc described by the stylus. Supplied in the accessory kit is a 45 RPM spindle adaptor. The adaptor has been specially marked with an arrow and a circle to aid you in setting the proper stylus overhang. Proceed as follows:

1. With the turntable stopped, place the 45 RPM adaptor on the center spindle with the arrow pointing to the rear of the turntable.
2. Remove the arm from its arm rest and remove the protective cover (if any) from the stylus.
3. Place the stylus tip over the 45 RPM adaptor and adjust the cartridge so that the stylus tip will be perfectly centered in the circle.
4. Make sure that the cartridge is installed straight. The sides of the cartridge must remain parallel to the sides of the shell.
5. Tighten the mounting screws.

● VERTICAL TONE ARM BALANCE

The adjustable counterweight at the end of the tone arm establishes tone arm balance and stylus tracking force. Since no two types of cartridges weigh the same, the balance and tracking force must be adjusted for each cartridge being used.

First, to establish a point of reference, the entire arm assembly (with cartridge installed) must be balanced. If the cartridge has a removable stylus protector, remove it (as you would to play a record). Release the tone arm from the arm rest.

To adjust the tone arm balance, set the anti-skate dial at minimum (see Figure 3).

To balance the arm, adjust the position of the counter-

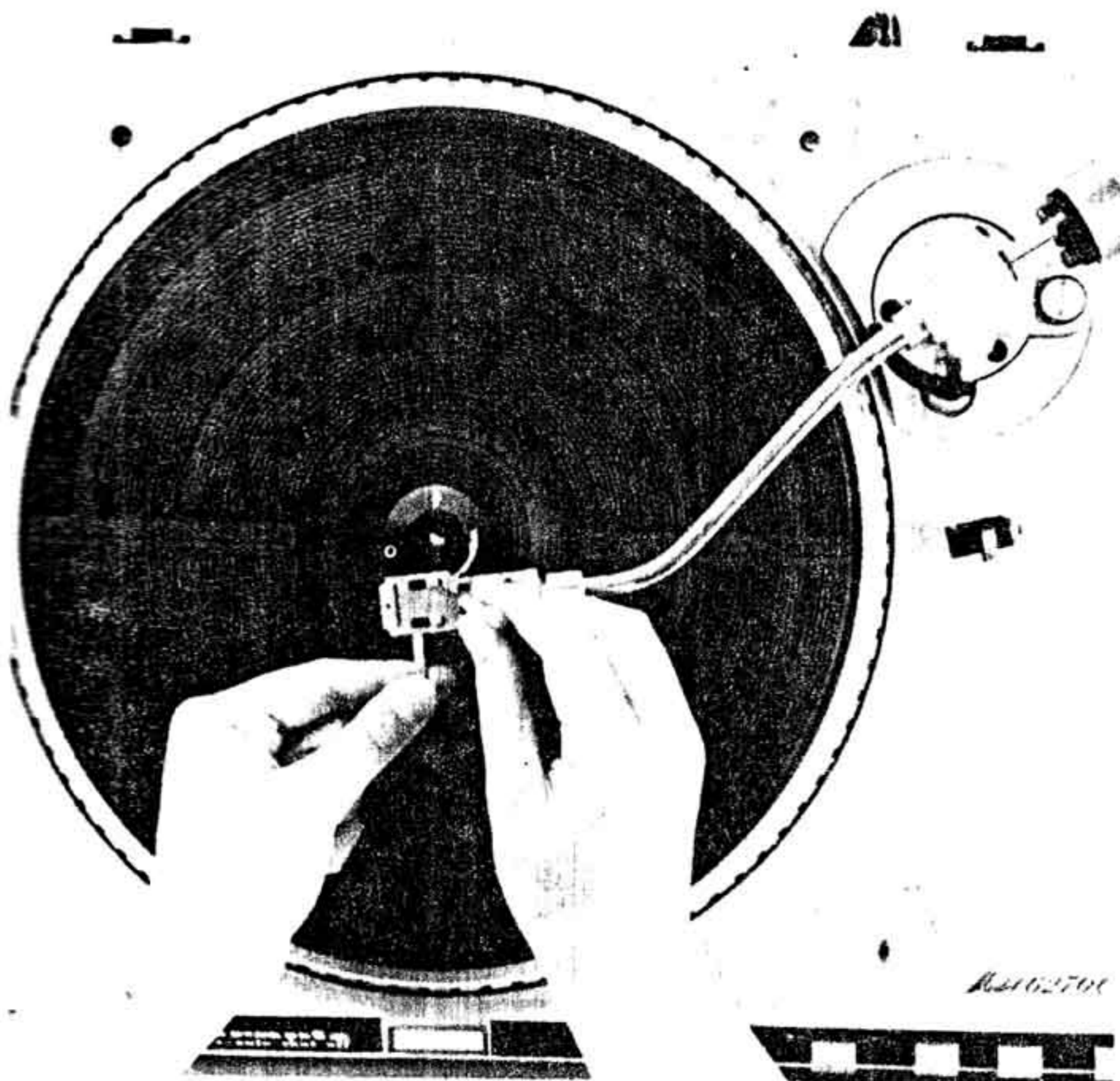

Figure 1. Stylus Overhang Adjustment



Figure 2. Tone Arm Balance Adjustment

weight by rotating it. A numbered stylus pressure scale plate is located immediately in front of the counterweight. Rotating the scale plate alone does not change the counterweight's position. To change the balance, grasp and turn the counterweight itself.

Adjust the weight so that the arm is level (parallel to the turntable surface) with the cartridge suspended in midair. Then, without moving the counterweight, set the stylus pressure scale plate to indicate zero. This establishes a reference point for setting the tracking force.

• TRACKING FORCE

For the recommended tracking force, refer to the instructions that accompany the cartridge.

Tracking force, the downward pressure of the stylus against the record, is produced by simply setting the arm off balance in the appropriate direction. That is, the counterweight is screwed inward (toward the arm pivot) until the desired downward pressure is achieved.

The stylus pressure scale plate is in frictional contact with the counterweight, so that they rotate together when the counterweight is turned. The numbers on the scale plate correspond to the tracking force measured in grams. So, if the desired tracking force is two grams, turn the counterweight inward until the stylus pressure scale plate registers 2.

• ANTI-SKATING ADJUSTMENT

The anti-skating mechanism is provided to counteract the natural tendency of the arm to "skate" toward the center of the record as it is being played. The more tracking force used, the more anti-skating force required.

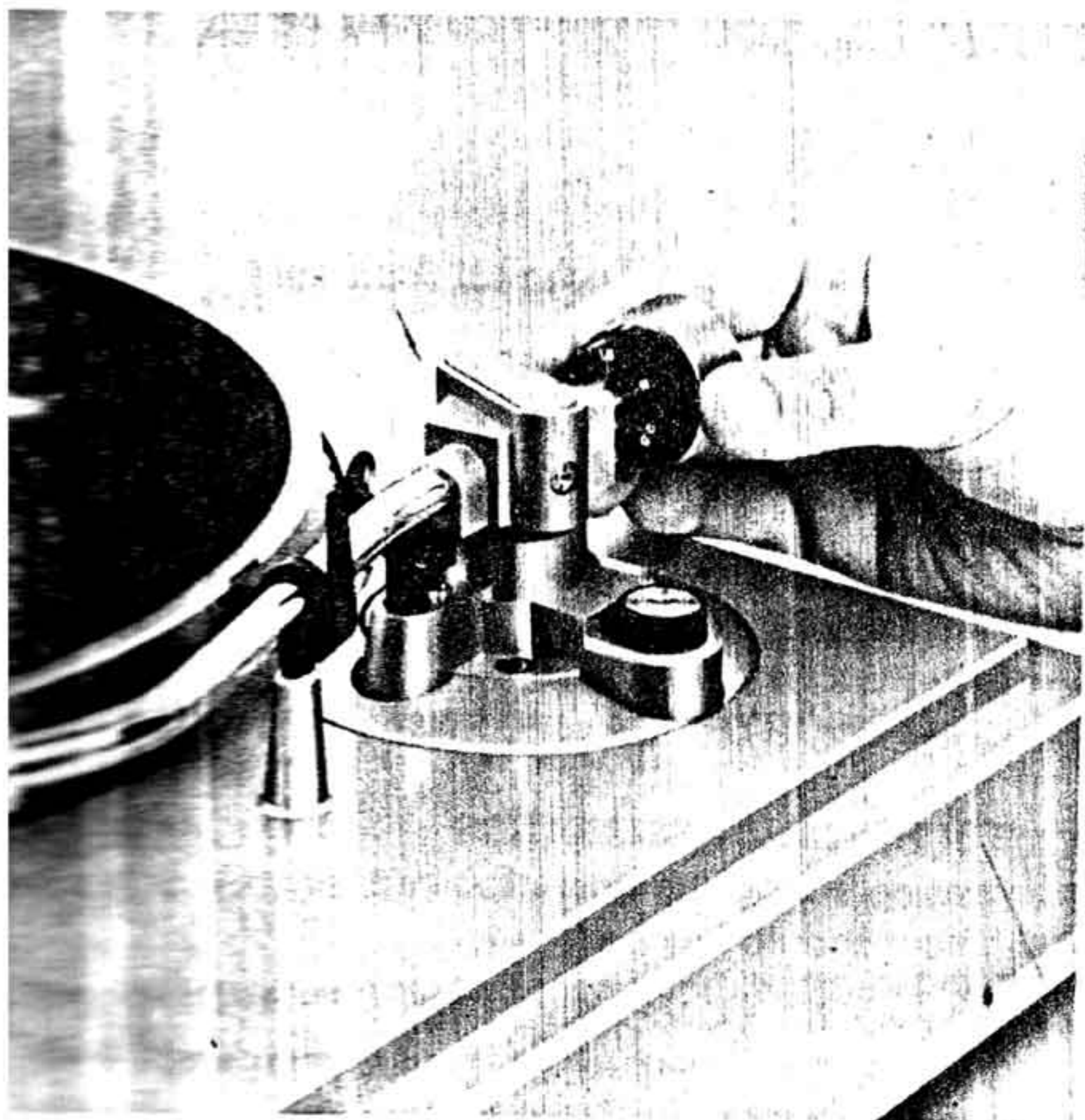
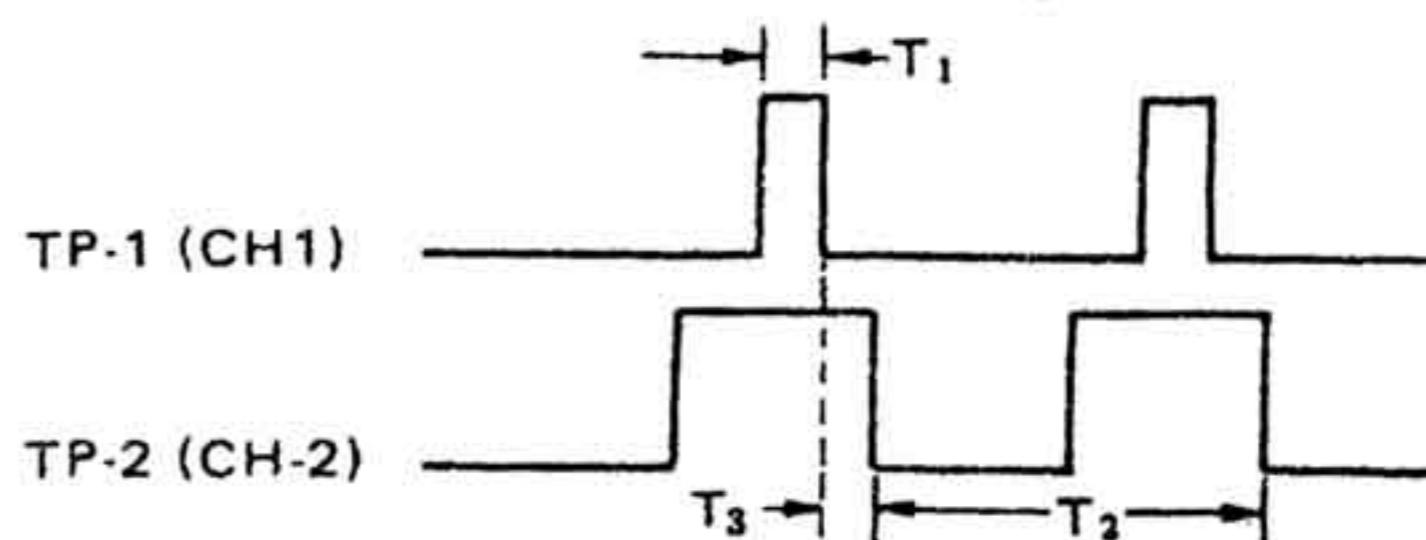

Figure 3. Anti-Skating Mechanism

The anti-skating force is adjustable with continuous graduations that correspond to the tracking force markings on the stylus pressure scale plate. Set the anti-skating force to the same value as the tracking force. Place the arm in the arm rest, and secure it with the safety lock.

2.2 CHECK AND ADJUSTMENT PROCEDURE OF M6270Q MOTOR DRIVE PWB

1. Oscillator Frequency Check
Frequency between the negative (-) terminal and TP-1
50 Hz (20 mS) for 33-1/3 rpm
67.5 Hz (14.815 mS) for 45 rpm
2. Synchronization Adjustment
 - 1) Connect the negative (-) terminal to GROUND, TP-1 to CH1 and TP-2 to CH2 using a two-phenomenon oscilloscope.
 - 2) Select a speed of 45 rpm.
 - 3) Adjust VR1 of M001 until T3 has ± 1 mS.
 - 4) Select a speed of 33 rpm.
 - 5) Adjust VR2 of M001 until T3 has ± 1 mS.
 - 6) Check to make sure that T1 ranges from 0.8 to 1.8 mS when a speed is 33 rpm.



3. Current Value Check
Check current at the positive (+) 24 V DC terminal.
No-load current: Less than 100 mA
Locked rotor current: 400 to 700 mA in locking

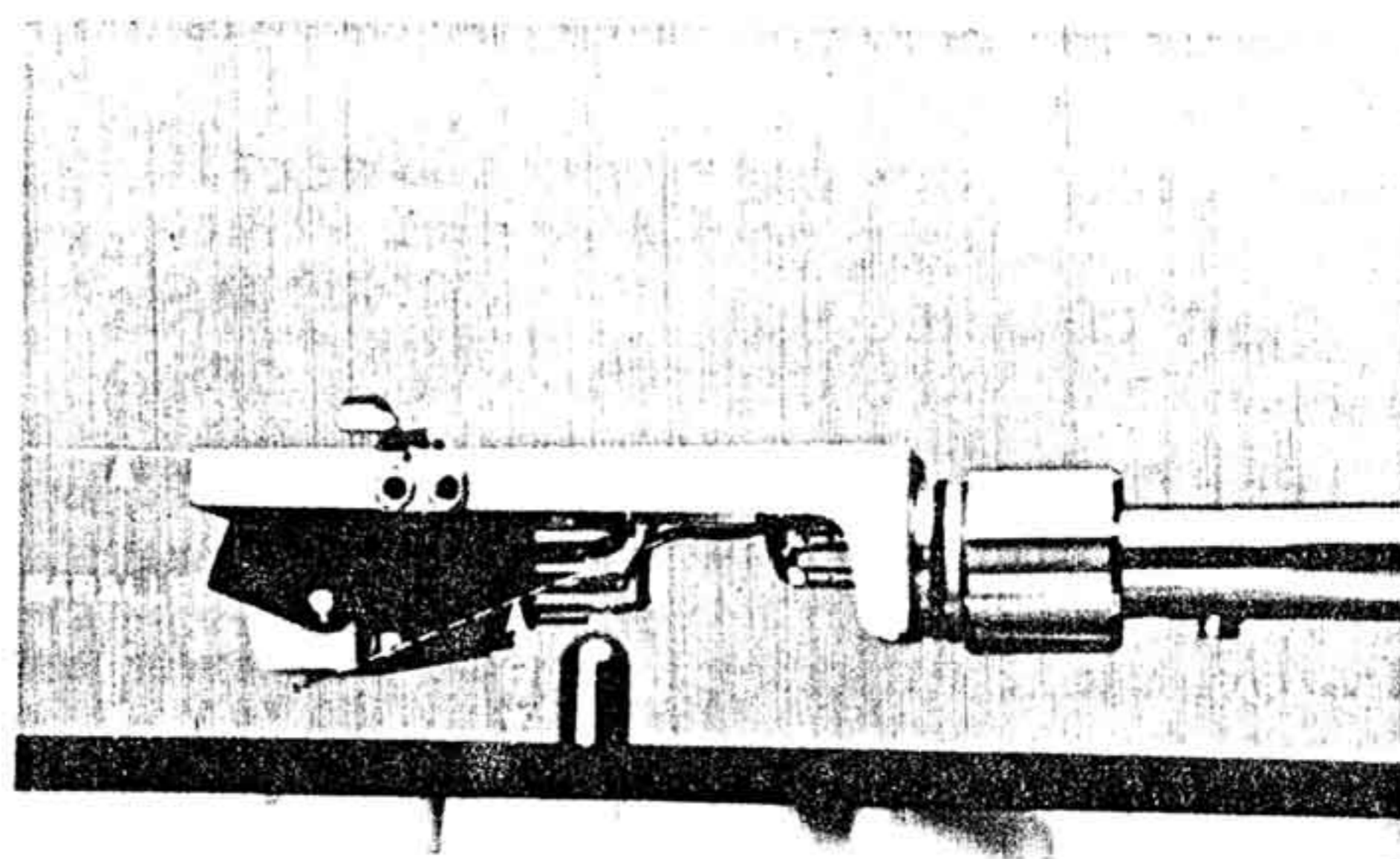

Figure 4. Tracking Angle

3. SERVICE NOTES

3.1 Voltage Conversion for European Model

The European version of the Model 6270Q is equipped with a universal power transformer that may be adjusted to operate at 110V, 120V, 220V or 240V AC at 50 to 60 Hz. To convert the unit to a different power source voltage, reposition conversion plug as shown in the illustration below.

CAUTION
DISCONNECT POWER SUPPLY CORD FROM AC OUTLET BEFORE CONVERTING VOLTAGE.

Figure 5. Voltage Conversion Chart

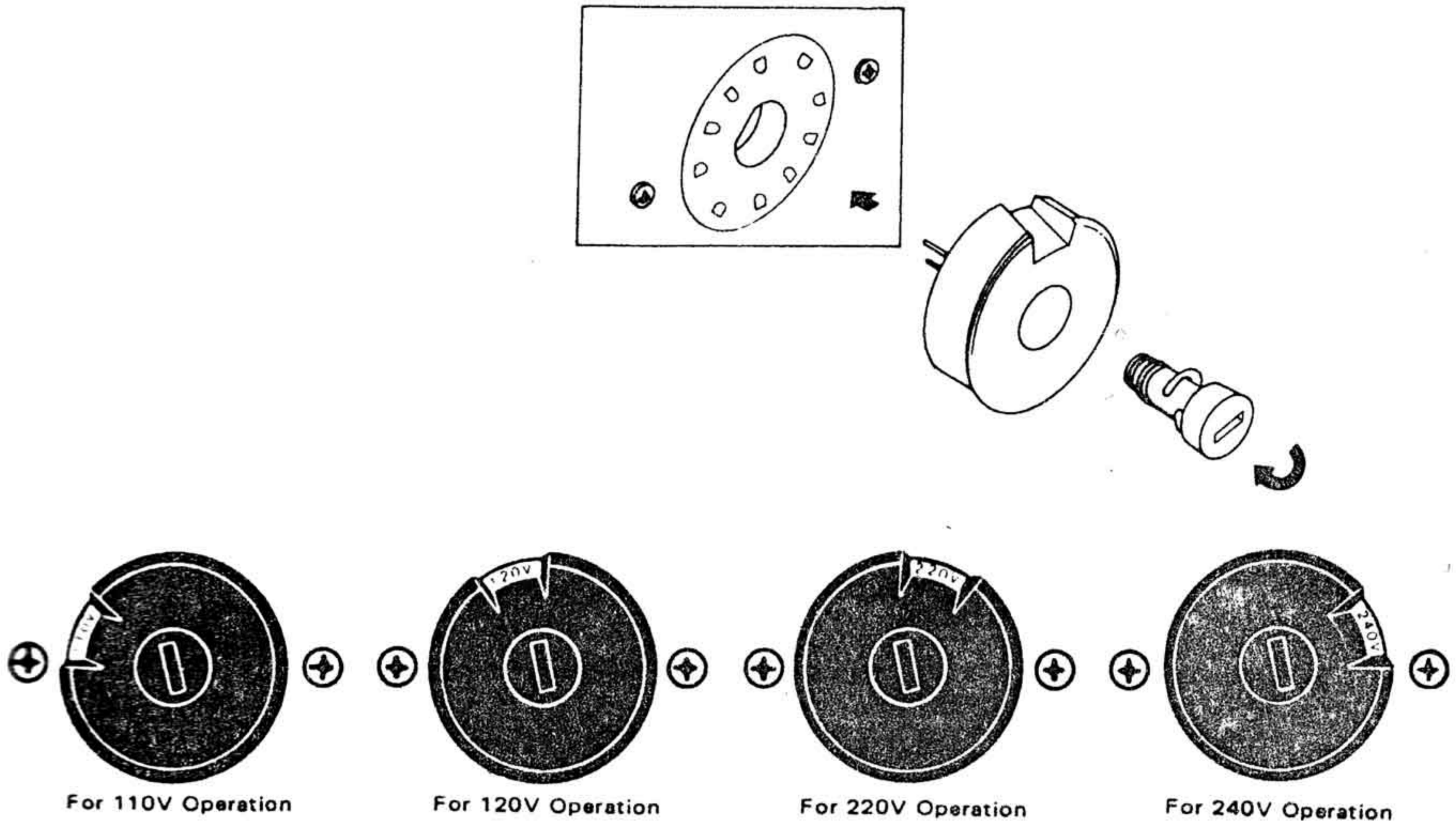

3.2 Cartridge Wire Color Code

Before a cartridge is screwed into the shell, the small clips at the ends of the wires in the tone arm cartridge shell should be pushed onto their corresponding cartridge connection pins.

**TONE ARM CARTRIDGES SHELL
- WIRE COLOR CODE -**

RIGHT CHANNEL HOT	RED
RIGHT CHANNEL GROUND	GREEN
LEFT CHANNEL HOT	WHITE
LEFT CHANNEL GROUND	BLUE

The cartridge or its accompanying technical sheet will identify the cartridge connection pins. It may be necessary to slightly compress the terminal clips with your fingers to make them fit snugly on the prongs of some cartridges.

3.3 Replacement Parts/Technical Assistance

1. REPLACEMENT PARTS

Turntable replacement parts may be ordered by writing to:

**MARANTZ COMPANY, INC.
PARTS DEPARTMENT
P.O. BOX 577
CHATSWORTH, CALIFORNIA 91311 USA**

2. TECHNICAL ASSISTANCE

Inquiries regarding the operation and servicing of Marantz equipment should be directed to:

**MARANTZ COMPANY, INC.
TECHNICAL SERVICES DEPARTMENT
P.O. BOX 577
CHATSWORTH, CALIFORNIA 91311 USA**

4. DIAGRAM AND COMPONENT LOCATIONS

4.1 Switch Assembly (PS01) Schematic Diagram and Component Locations

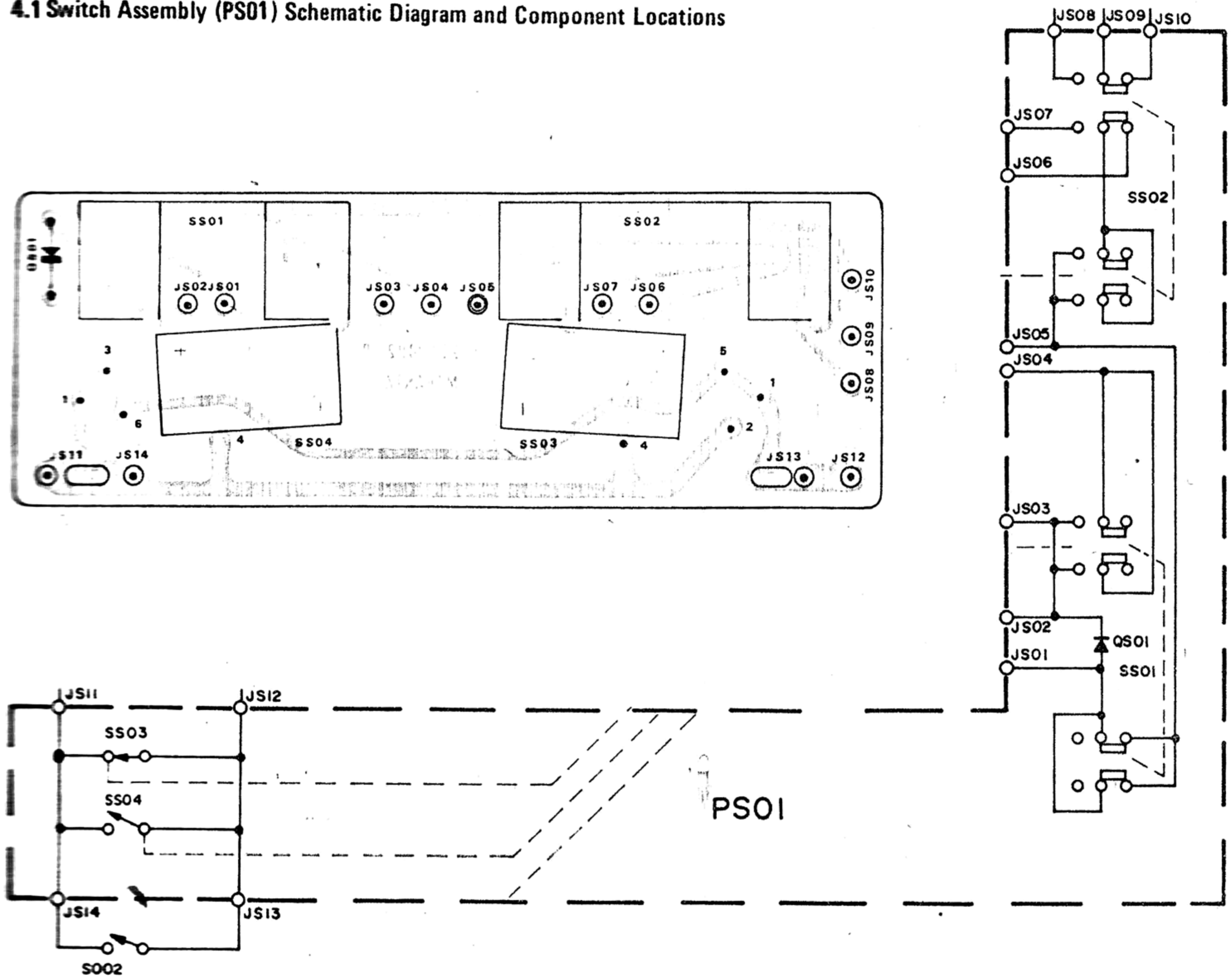

4.2 Led. Switch Assembly (PT01) Schematic Diagram and Component Locations

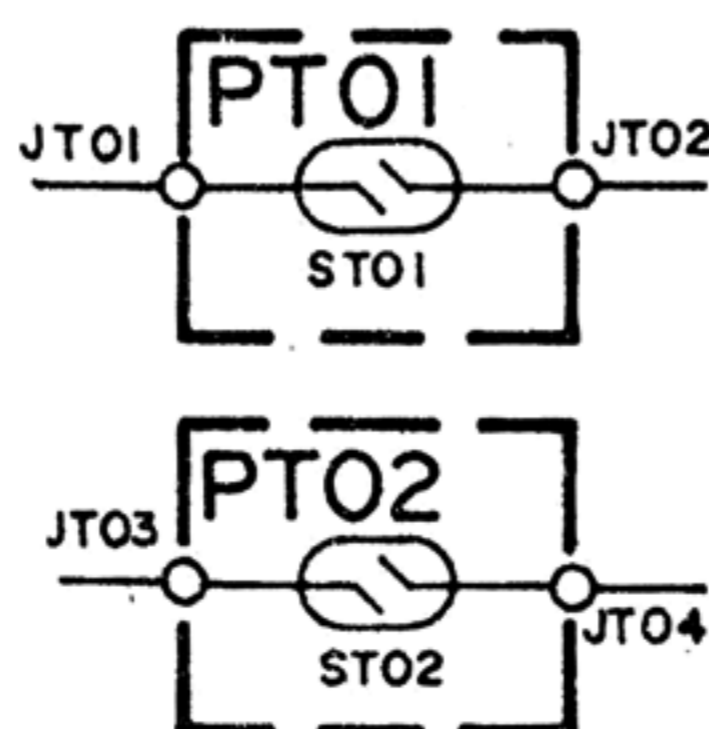
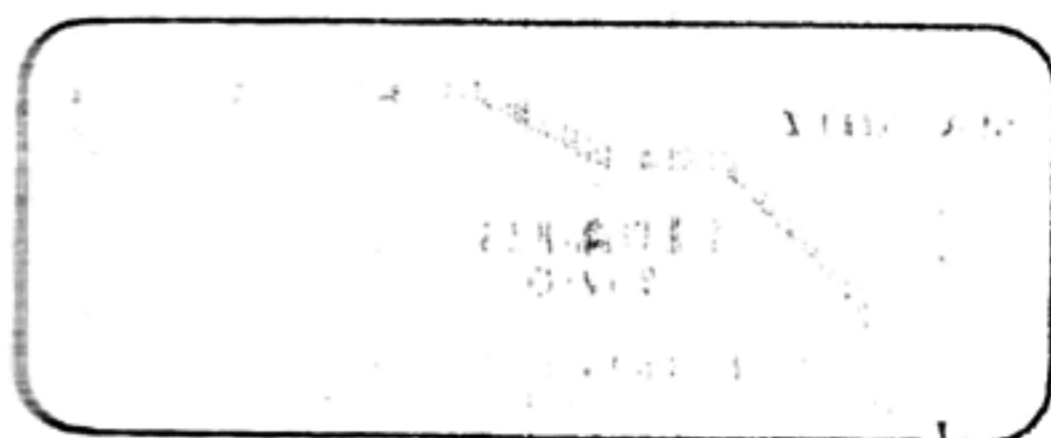

4.3 Led. Switch Assembly (PT02) Schematic Diagram and Component Locations

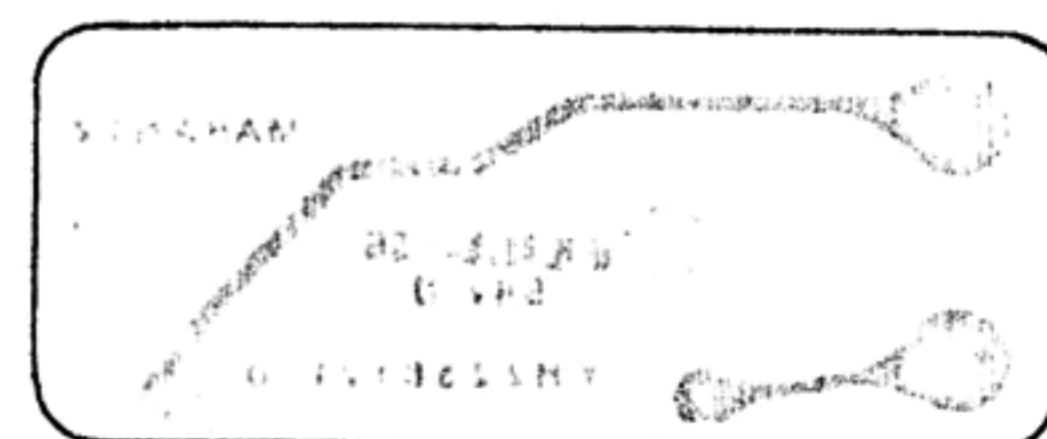

4.4 Power Supply Assembly (P800) Schematic Diagram and Component Locations

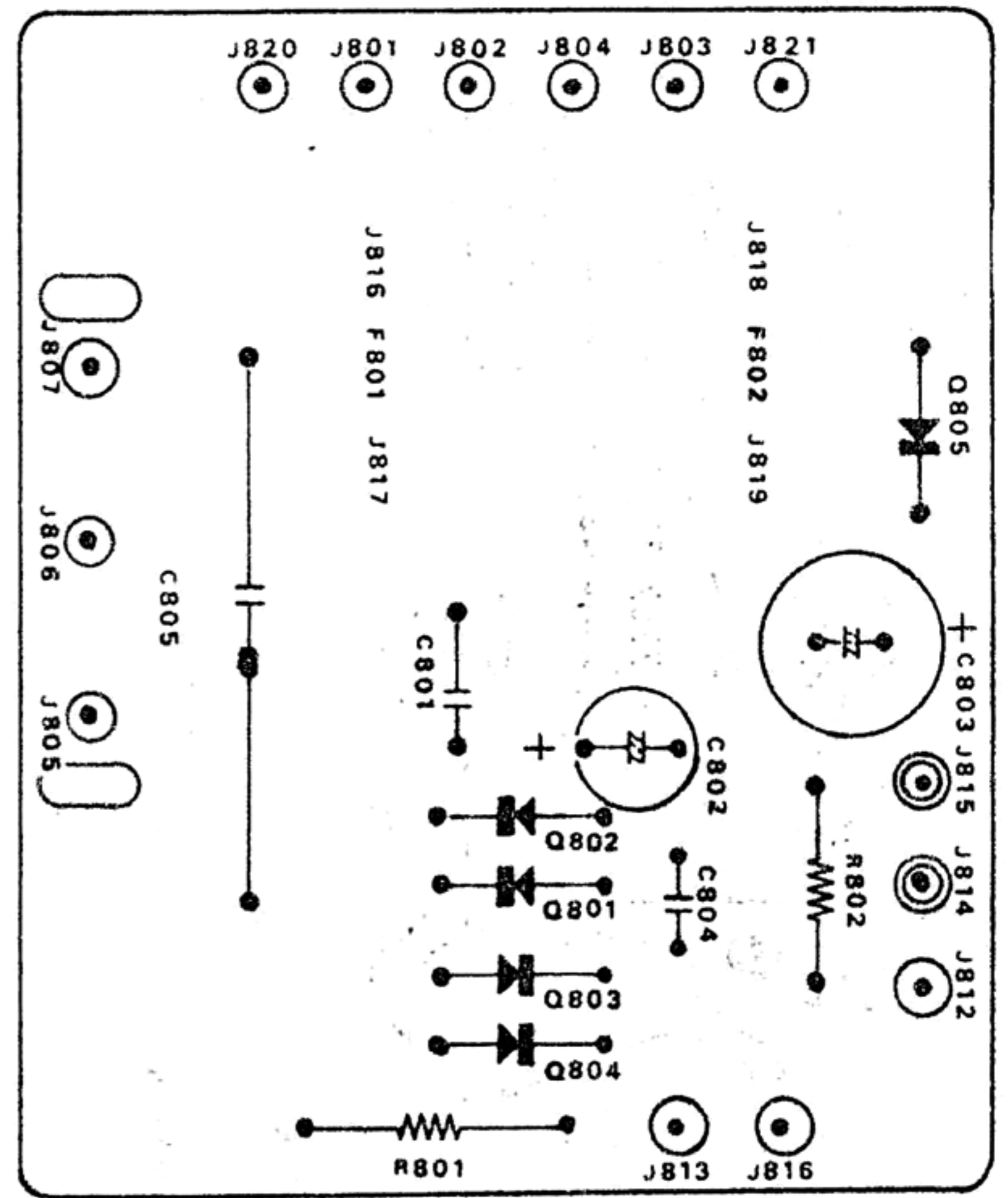
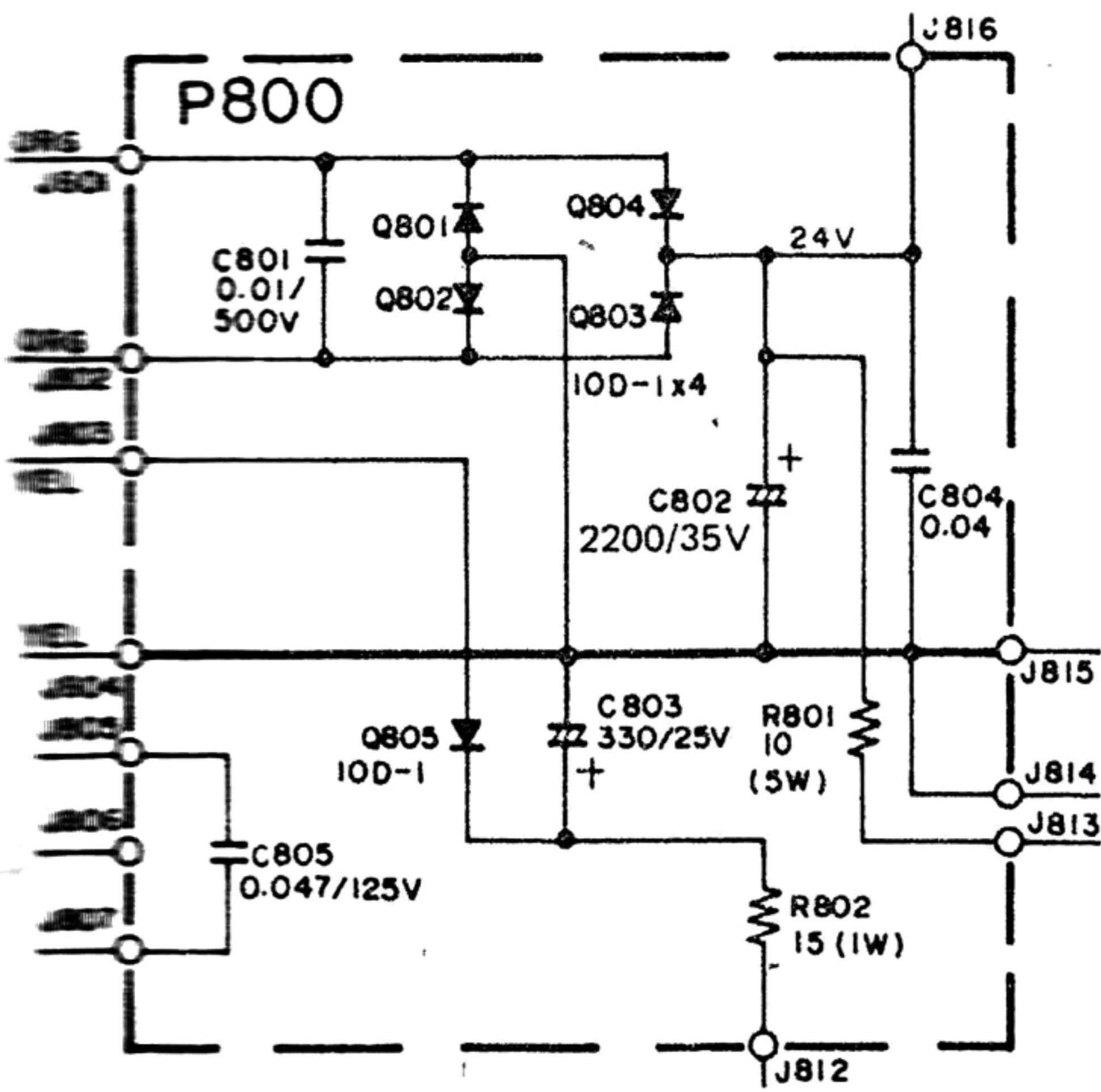

4.5 Led. Assembly (PY00) Schematic Diagram and Component Locations

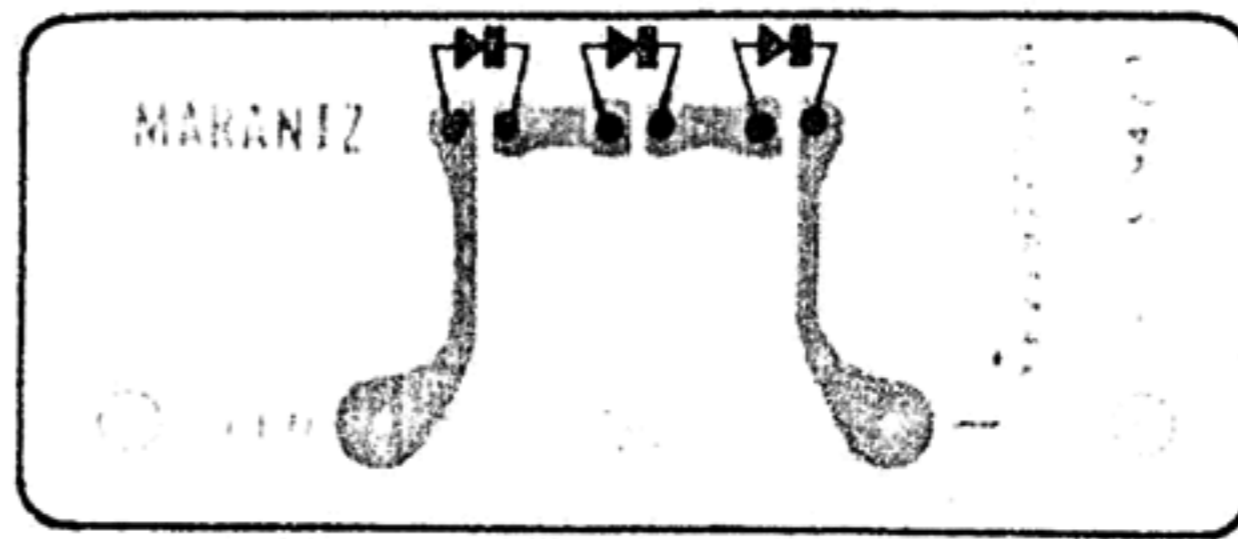
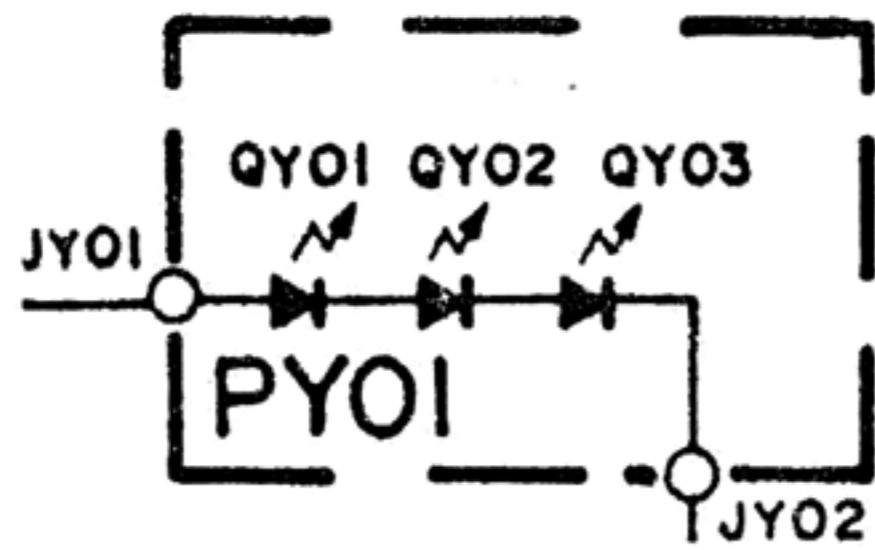

4.6 Connective Assembly (PV03) Schematic Diagram and Component Locations

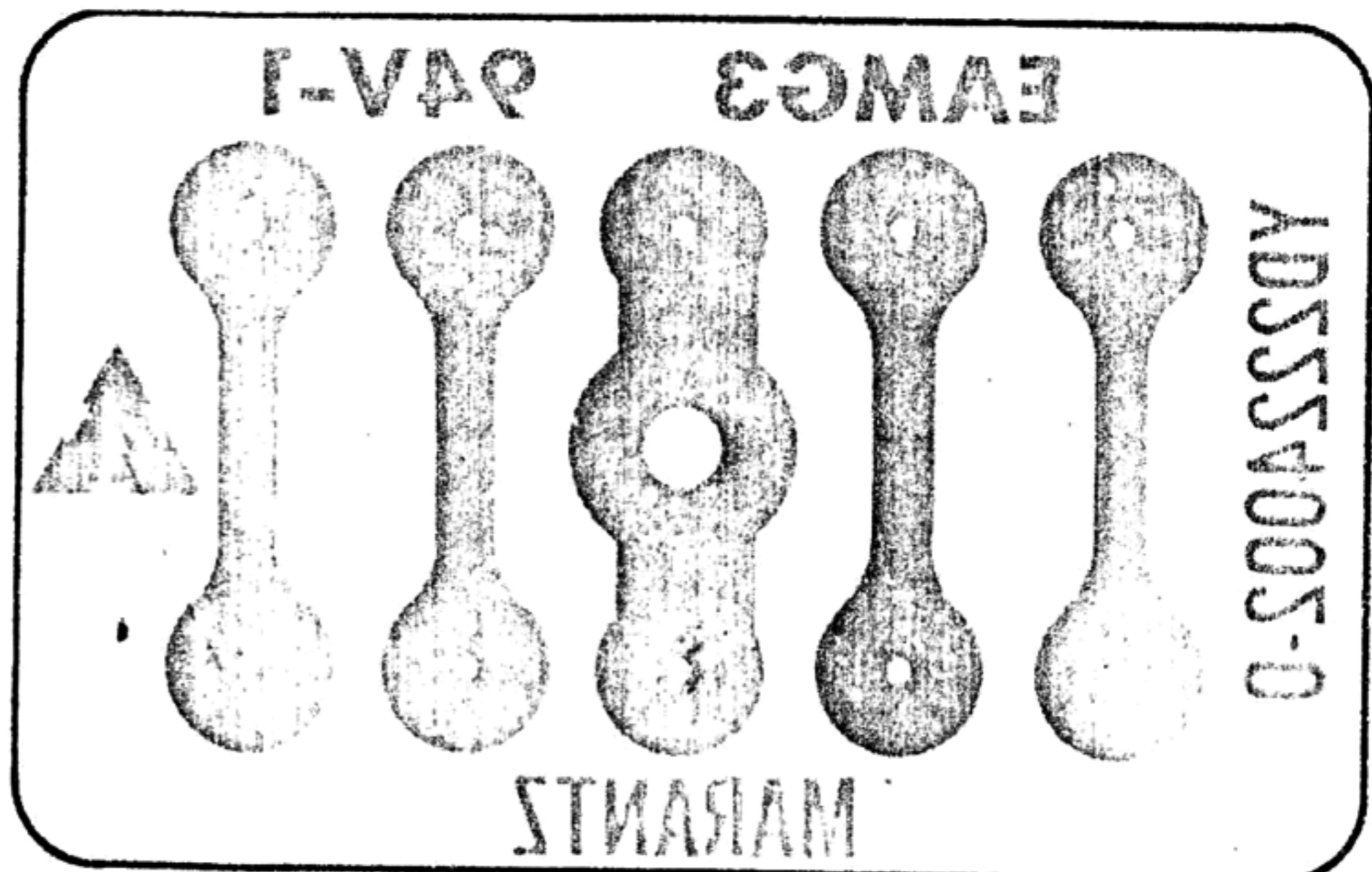
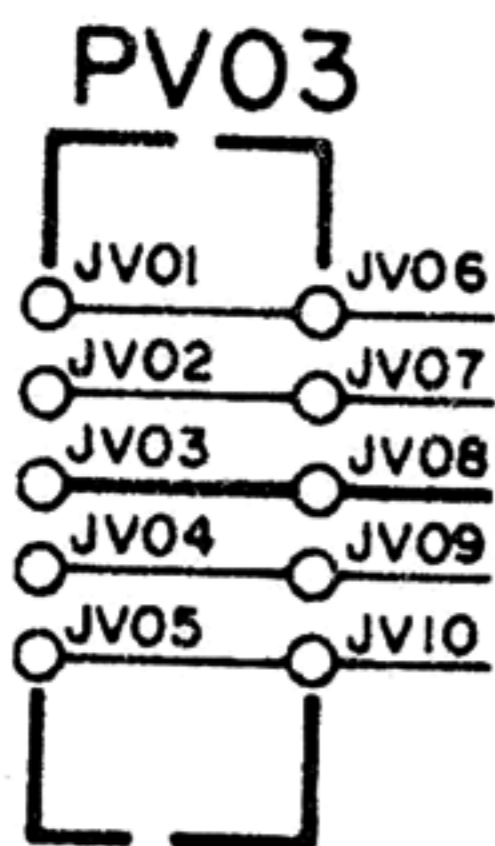

5. SCHEMATIC DIAGRAM

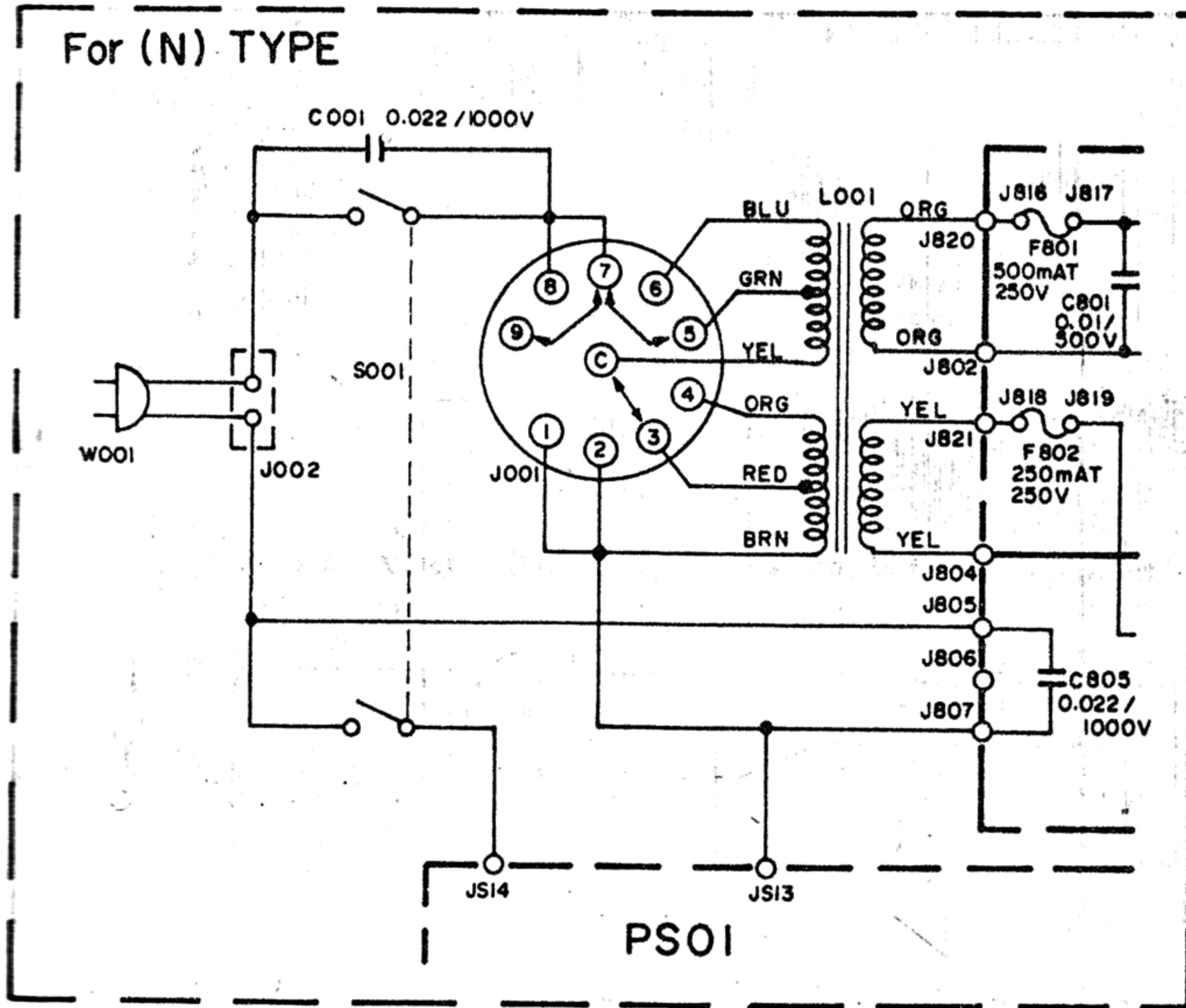

Q801~Q805
HD20013100
10D1

QS01
HD20003210
IS2471

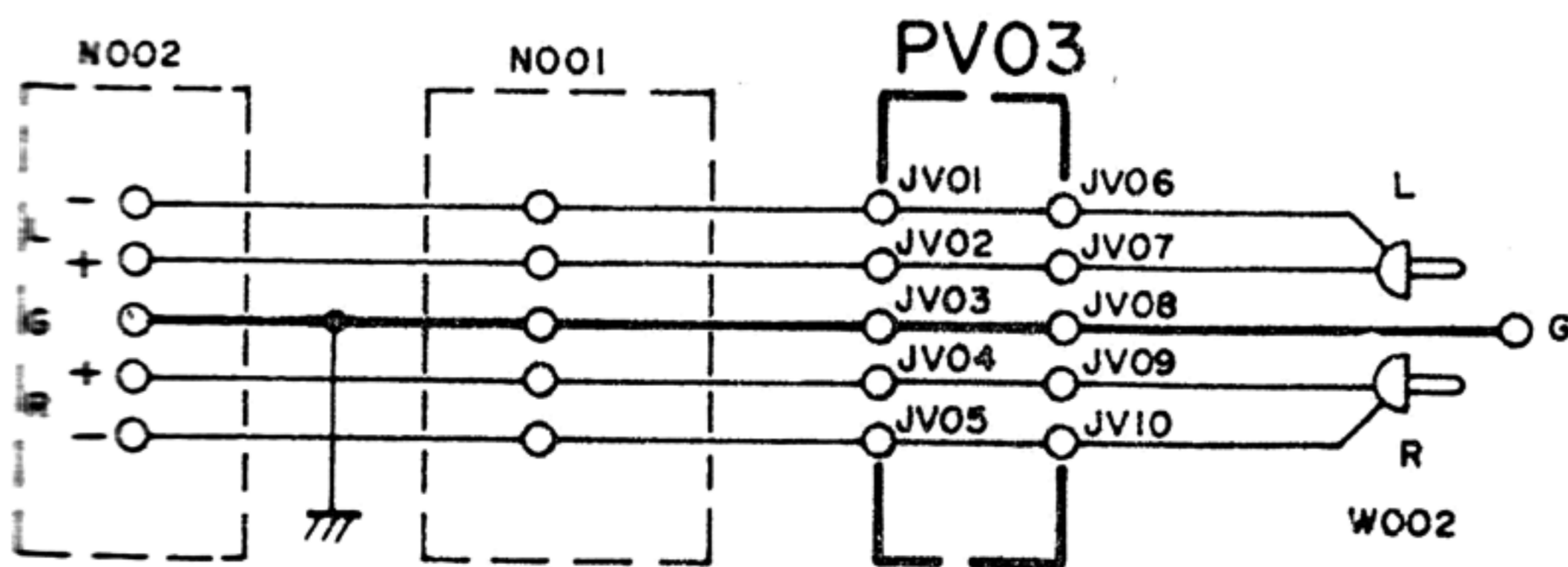
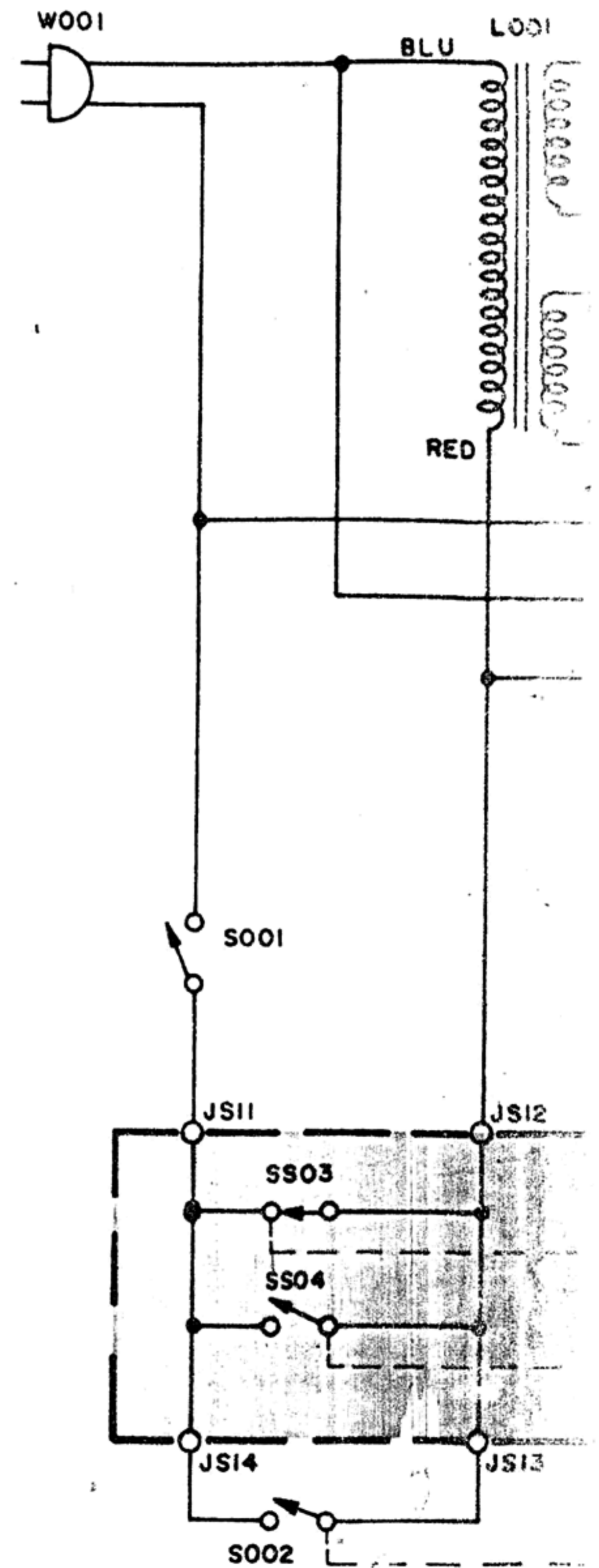

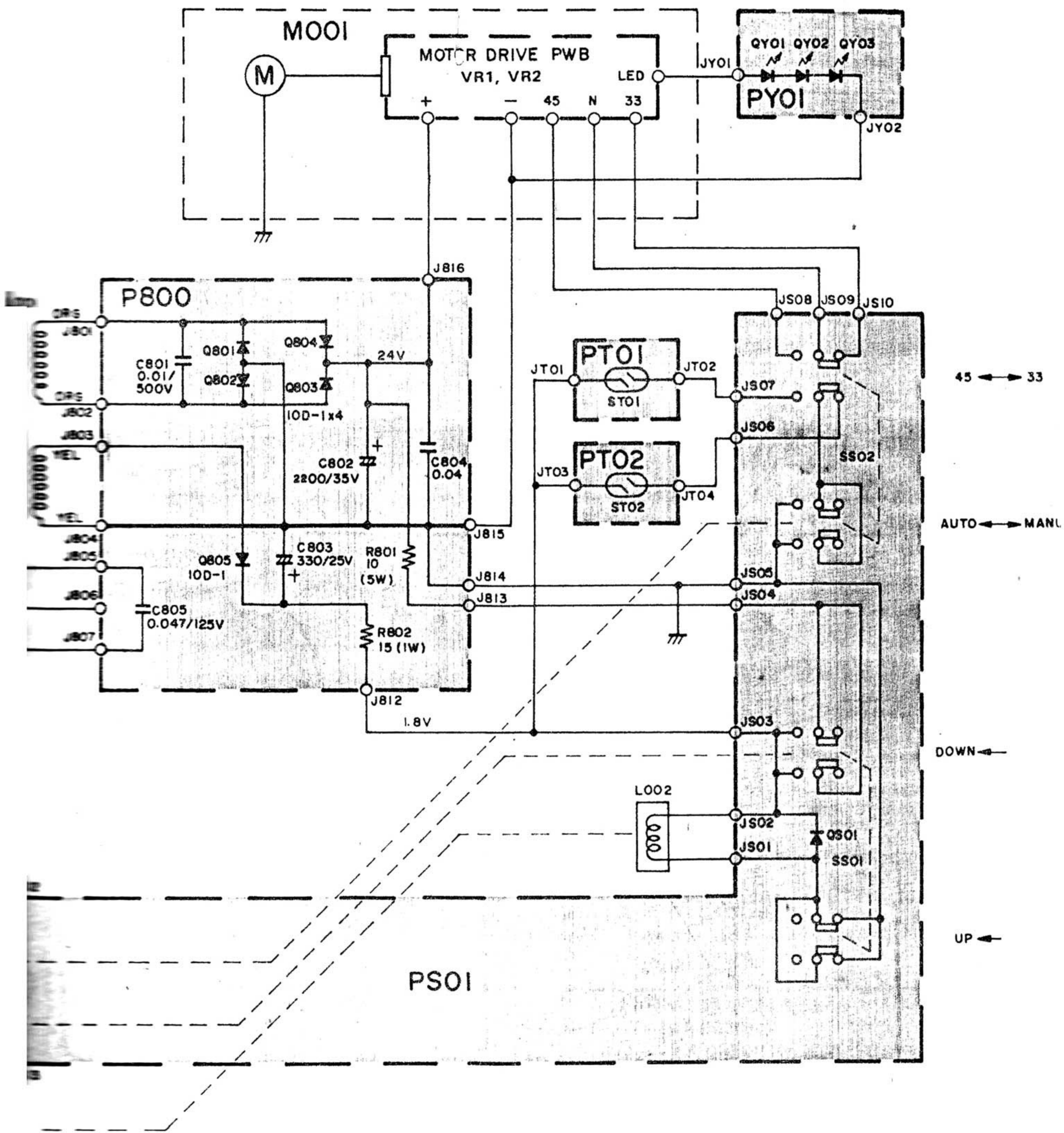

EXPLODED VIEW AND PARTS LIST

[C01-99] Case and General Parts

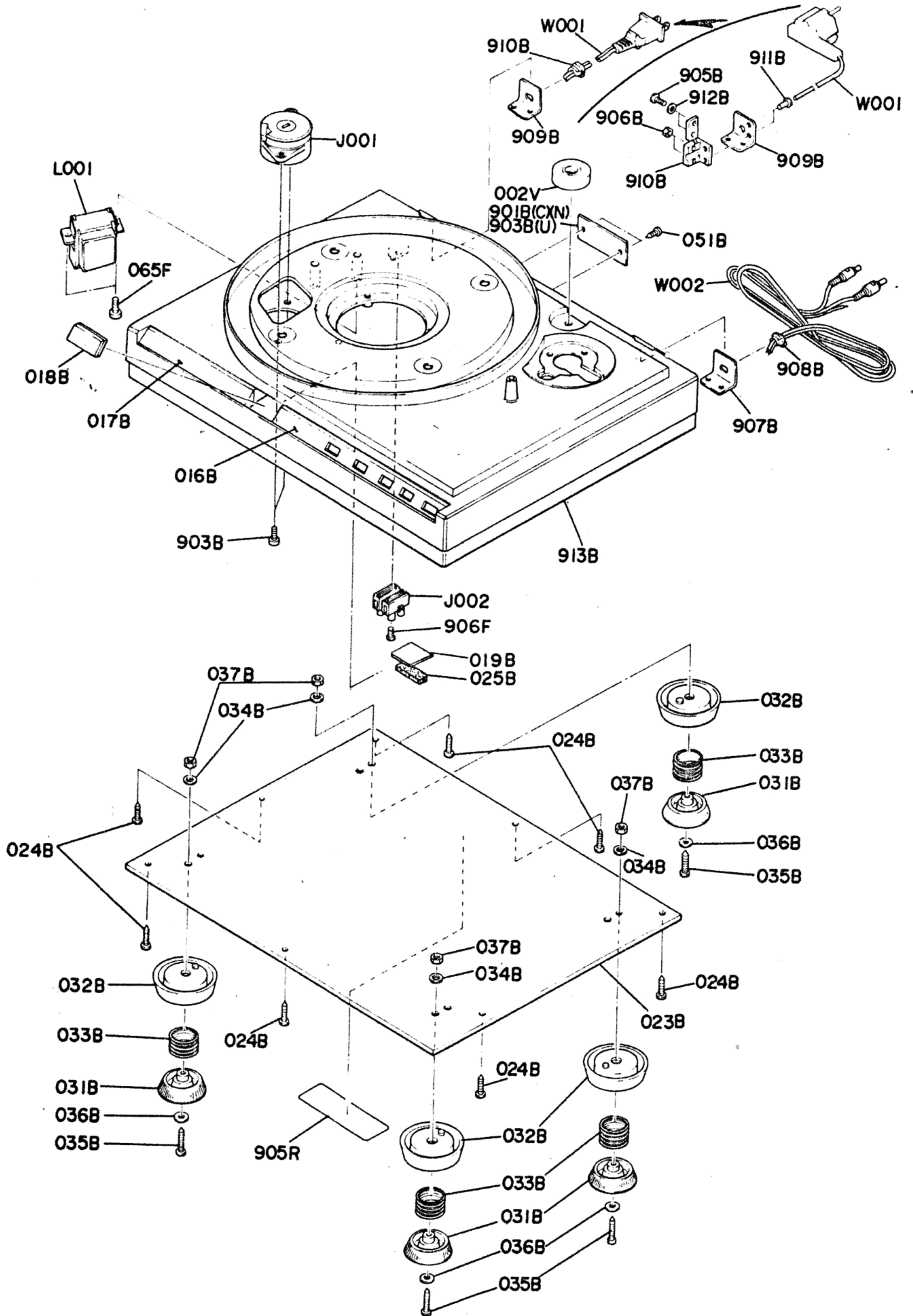

REF. DESIG.	Q'TY			PART NO.	DESCRIPTION
	U	C	N		
A	1	1		2292064400	Case Assembly
A1			1	2292064410	Case Assembly
016B	1	1	1	2292063010	Escutcheon
017B	1	1	1	2292063020	Escutcheon
018B	1	1	1	2292158010	Window
019B	1	1	1	2292274020	Reflector
025B	1	1	1	2292056010	Buffer
913B	1	1		2292064012	Case
913B			1	2292064112	Case
023B	1	1	1	2292257012	Lid
024B	7	7	7	51280314B0	B.H. Tapped Screw B3 x 14
031B	4	4	4	2224057012	Reg
032B	4	4	4	2292053010	Cover
033B	4	4	4	2224115030	Spring
034B	4	4	4	54110149A0	Flat Washer, L
035B	4	4	4	51100320A9	B.H.M. Screw B3 x 20
036B	4	4	4	54020301A0	Flat Washer, P
037B	4	4	4	53110303A9	Hexagon Nut
051B	2	2	2	51760306B0	OS Tapped Screw
901B		1		2292265022	Indicator
901B			1	2292265032	Indicator
903B	1			2292265010	Indicator
903B			2	51100308A9	B.H.M. Screw B3 x 8
906B			2	51100312A9	B.H.M. Screw B3 x 12

REF. DESIG.	Q'TY			PART NO.	DESCRIPTION
	U	C	N		
906B			2	53110303A9	Hexagon Nut
907B	1	1	1	2224160042	Bracket
908B	1	1	1	1455259070	Bushing
909B	1	1		2224160032	Bracket
909B			1	2262160050	Bracket
910B	1	1		1455259030	Bushing
910B			1	2821259010	Bushing
911B			2	55060305S0	T.R. Rivet
912B			2	54050300R0	T.L. Washer OR
065F	2	2	2	51100408A9	B.H.M. Screw B4 x 8
906F			1	51280316B0	B.H. Tapped Screw B3 x 16
905R		1		9510911010	Label
002V	1	1	1	2272362020	REC Adaptor
J001			1	BY03110010	Plug
J002			1	YL09020040	Terminal
L001	1	1		TS15407050	Power Transformer
L001			1	TS15407070	Power Transformer
W001	1	1		YC02000140	A.C. Power Cord
W001			1	YC01800160	A.C. Power Cord
W002	1	1	1	YB01000060	Connective Cord

F01-99] Turn Table and Motor

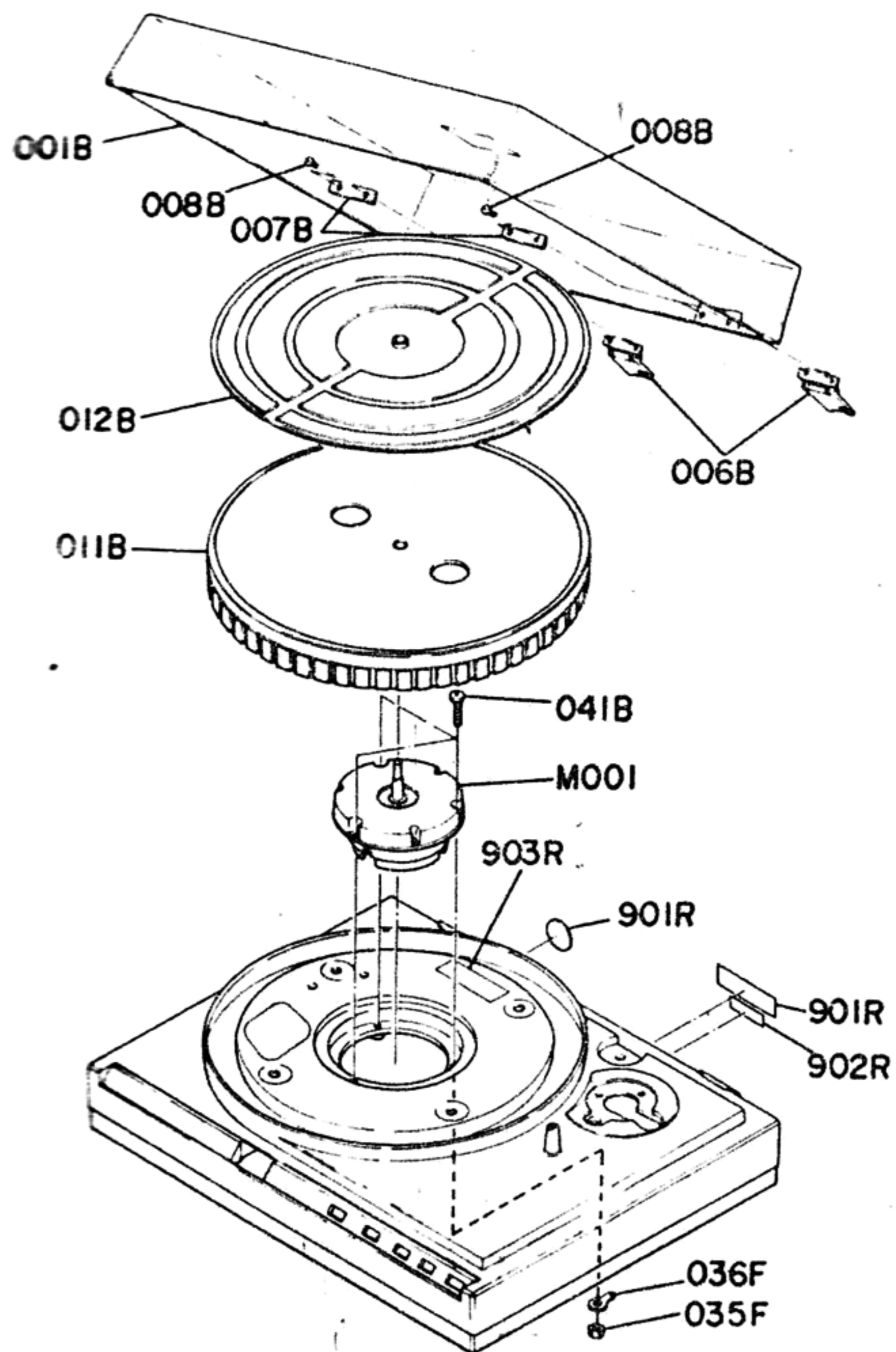

REF. DESIG.	Q'TY			PART NO.	DESCRIPTION
	U	C	N		
B	1	1	1	2224053400	Dust Cover Assembly
001B	1	1	1	2224053513	Cover
006B	2	2	2	2224153512	Hinge
007B	2	2	2	2224160260	Bracket
008B	4	4	4	51100410S9	B.H.M. Screw B4 x 10
011B	1	1	1	2292165010	Turntable
012B	1	1	1	2224107020	Sheet
041B	3	3	3	51100416A9	B.H.M. Screw B4 x 16
035F	1	1	1	53110403B9	Hexagon Nut
036F	1	1	1	62040029W0	Lug
901R	1			9511101060	Label
901R		1		2457861040	Label
901R			2	3889861010	Label
902R			1	2255861040	Label
903R	2			3889861010	Label
903R		2		2911861182	Label
M001	1	1	1	PM23300070	Phonomotor Unit

F02-99] Tone Arm

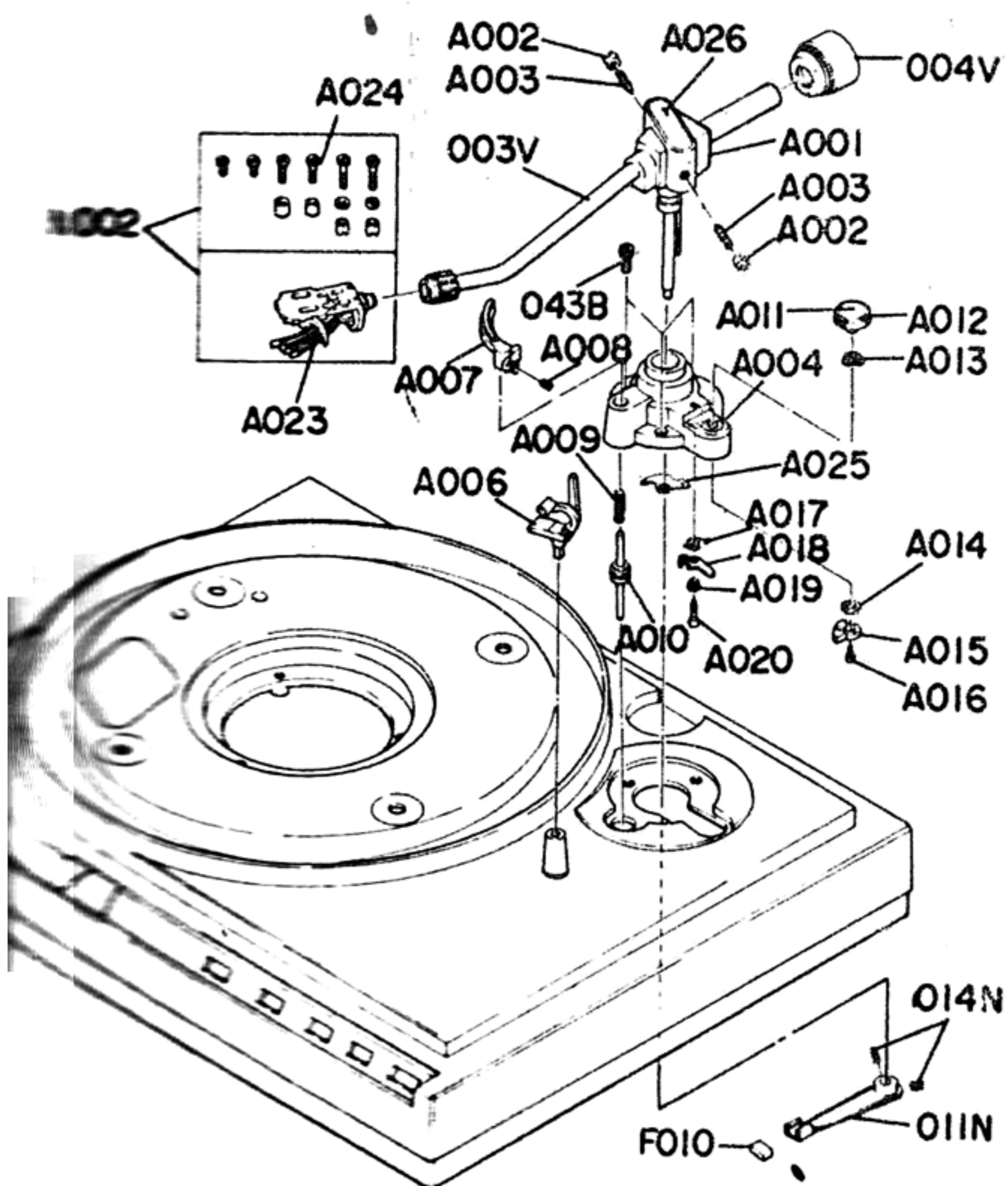

REF. DESIG.	Q'TY			PART NO.	DESCRIPTION
	U	C	N		
A001	1	1	1	2271002210	Pipe Arm Assembly
A002	2	2	2	2271104210	Nut
A003	2	2	2	2271104220	Pivot
A004	1	1	1	2292100210	Base Bracket Assembly
A006	1	1	1	2271005210	Arm Rest Assembly
A007	1	1	1	2271101210	Arm Support Assembly
A008	1	1	1	51650305B9	Socket Screw HD 3 x 5
A009	1	1	1	2271115210	Spring
A010	1	1	1	2292112210	Lifter Shaft Assembly
A011	1	1	1	2271063210	Plate
A012	1	1	1	2271154210	Knob
A013	1	1	1	2271115220	Spring
A014	1	1	1	59050805G9	Washer
A015	1	1	1	2271054210	Cam
A016	1	1	1	51380205A0	P.H. Tapped Screw P2 x 5
A017	1	1	1	2271115230	Spring
A018	1	1	1	2271354210	Lever Assembly
A019	1	1	1	2271055210	Collar
A020	1	1	1	51382605J0	P.H. Tapped Screw P2.6 x 5
A023	1	1	1	YS02040160	Head Shell
A024	1	1	1	2292160220	Screw Head Shell
A025	1	1	1	2271104230	Retainer
A026	1	1	1	2292203210	Name Plate
043B	3	3	3	52730412S9	H.S. Head Bolt H4 x 12
N002	1	1	1	YS02040120	Head Shell
004V	1	1	1	2271008010	Main Weight
011N	1	1	1	2256002533	Arm
014N	2	2	2	51690303Q9	Socket Screw, HP 3 x 3
F010	1	1	1	FD20100010	Ferrite Magnet

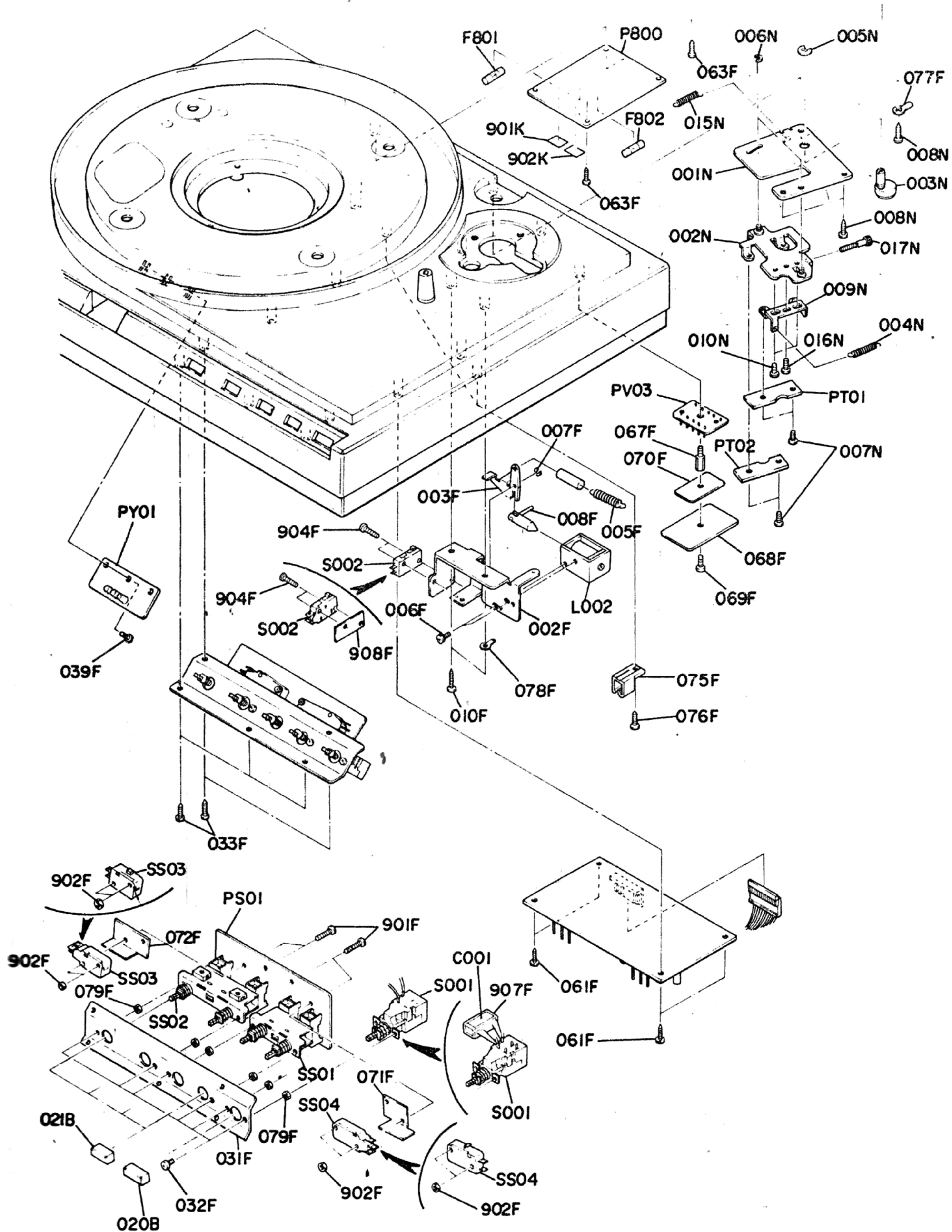

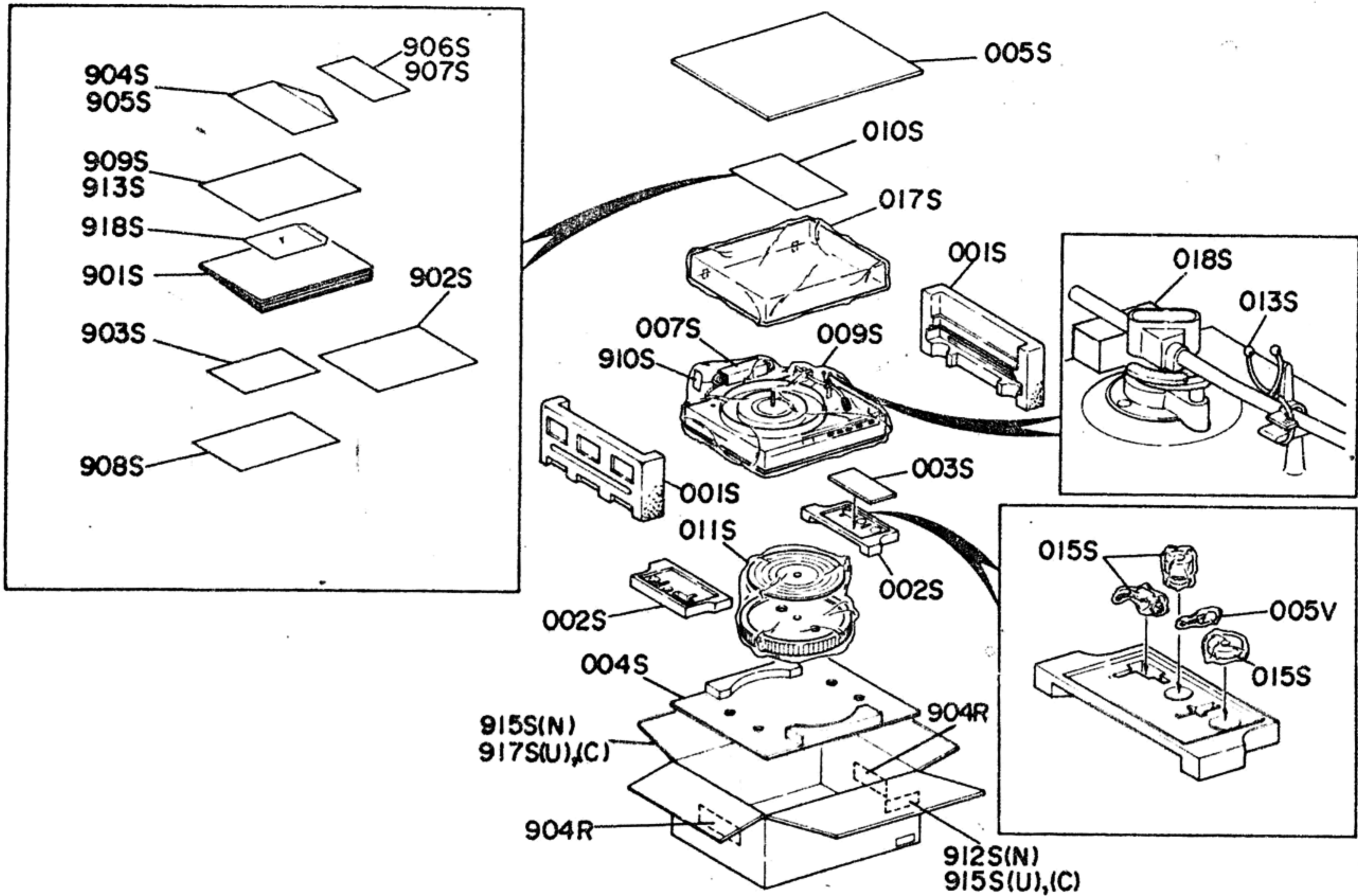

REF. DESIG.	QTY			PART NO.	DESCRIPTION
	U	C	N		
001S	2	2	2	2292809010	Cashion
002S	2	2	2	2292809020	Cashion
003S	1	1	1	2292807030	Reinforcing
004S	1	1	1	2292807010	Reinforcing
005S	1	1	1	2292807020	Reinforcing
007S	1	1	1	2864804010	Sleeve
009S	1	1	1	9090909040	Polyethy Bag
010S	1	1	1	9013025010	Polyethy Bag
011S	1	1	1	9013540010	Polyethy Bag
001S	1	1	1	2256005050	Clamper
002S	3	3	3	9010510010	Polyethy Bag
003S	1	1	1	9014543380	Polyethy Bag
004S	1	1	1	2292809030	Cushion
005S	1			2292851010	Instructions
006S	1	1		2292851310	Instructions
007S	1	1		2292851310	Instructions
008S	1			2292851020	Instructions
009S	1	1		2292851050	Instructions
010S	1	1		2292851030	Instructions
011S	1			2886851100	Insturctions
012S	1			2818813010	Envelope
013S	1			2918813012	Envelope
014S	1			9630000180	Guarantee Card

REF. DESIG.	QTY			PART NO.	DESCRIPTION
	U	C	N		
907S			1	9630000180	Guarantee Card
908S			1	9650000053	S. Station Card
909S			1	2818854042	Guarantee Card
910S			1	9560000043	Hang Tag
912S			3	9526019030	Serial No Card
913S	1			2818854024	Guarantee Card
915S	3			9526019010	Serial No Card
915S		3		9526019020	Serial No Card
915S			1	2292801010	Packing Case
917S	1			2292801010	Packing Case
917S		1		2292801150	Packing Case
918S	1			2225813010	Envelope
904R		2		9510901020	Label
005V	1	1	1	2939164010	Driver

7. ELECTRICAL PARTS LIST

REF. DESIG.	QTY			PART NO.	DESCRIPTION
	U	C	N		
P800	1	1	1	YF22920010	P100-POWER SUPPLY CIRCUIT BOARD P.W. Board Power Supply
	1	1		ZZ22920010	P.W. Board Assembly
			1	ZZ22928010	P.W. Board Assembly
P100-CAPACITORS					
C801	1	1	1	DK18103510	Ceramic 0.01 μ F \pm 20% 500V
C802	1	1	1	EA22803590	Elect 2200 μ F 35V
C803	1	1	1	EA33702590	Elect 330 μ F 25V
C804	1	1	1	DK18403010	Ceramic 0.04 μ F
C805	1			DF17473600	Film 0.047 μ F \pm 20% 125V
C805		1		DF17473590	Film 0.047 μ F \pm 20% 125V
C805			1	DF17223800	Film 0.022 μ F \pm 20% 1000V
P100-RESISTORS					
R801	1	1	1	GS10210050	21 Ω \pm 10% 5W
R802	1	1	1	GA05150010	15 Ω \pm 5% 1W
P100-SEMICONDUCTORS					
Q801	1	1	1	HD20013100	Diode 10D1
Q802	1	1	1	HD20013100	Diode 10D1
Q803	1	1	1	HD20013100	Diode 10D1
Q804	1	1	1	HD20013100	Diode 10D1
Q805	1	1	1	HD20013100	Diode 10D1
P800-MISCELLANEOUS					
F801			1	FS10050800	Fuse 250V 500mA
F802			1	FS10025800	Fuse 250V 250mA
J805			1	YL01010040	Terminal
J807			1	YL01010040	Terminal
J816			1	YJ08000200	Jack
J817			1	YJ08000200	Jack
J818			1	YJ08000200	Jack
J819			1	YJ08000200	Jack

REF. DESIG.	QTY			PART NO.	DESCRIPTION
	U	C	N		
PS01	1	1	1	YF22920020	PS01-SWITCH CIRCUIT BOARD P.W. Board Switch
	1	1	1	ZZ22920020	P.W. Board Assembly
			1	ZZ22928020	P.W. Board Assembly
QS01	1	1	1	HD20003210	Diode 1S2471
JS13			1	YL01010040	Terminal
JS14			1	YL01010040	Terminal
SS01	1	1	1	SP02020370	Push Switch
SS02	1	1	1	SP02020380	Push Switch
SS03	1			SM01020350	Mini Switch
SS03			1	SM01020330	Mini Switch
SS03			1	SM01020340	Mini Switch
SS04	1			SM01020350	Mini Switch
SS04		1		SM01020330	Mini Switch
SS04			1	SM01020340	Mini Switch
PT01-L.E.D SWITCH CIRCUIT BOARD					
PT01	1	1	1	YH22561220	P.W. Board L.E.D Switch
	1	1	1	ZZ22561220	P.W. Board Assembly
ST01	1	1	1	SC01010280	Switch, LED
PT02-L.E.D SWITCH CIRCUIT BOARD					
PT02	1	1	1	YH22561210	P.W. Board L.E.D Switch
	1	1	1	ZZ22561210	P.W. Board Assembly
ST02	1	1	1	SC01010280	Switch, LED
PV03-CONNECTIVE CIRCUIT BOARD					
PV03	1	1	1	YD22240020	P.W. Board Connective
	1	1	1	ZZ22240020	P.W. Board Assembly
PY01-L.E.D CIRCUIT BOARD					
PY01	1	1	1	YF22920030	P.W. Board L.E.D
	1	1	1	YF22920030	P.W. Board Assembly
QY01	1	1	1	HI10002300	L.E.D Yellow
QY02	1	1	1	HI10002300	L.E.D Yellow
QY03	1	1	1	HI10002300	L.E.D Yellow

(W01-99)	Assembly and Wiring
(T01-99)	Adjustment
(X01-00)	Correction

8. TECHNICAL SPECIFICATIONS

FOR U.S.A. MODEL ONLY

Drive System	Direct Drive System
Drive Motor Type	Quartz Locked DC Servo
Rumble (NAB RRL)	69 dB
Wow and Flutter (NAB, WRMS)	0.025%
Tone Arm Length	8.46 inches (219 mm)
Platter Diameter	12.3 inches (320 mm)
Stylus Overhang	0.71 inches (18 mm)
Tracking Force	0 ~ 3.0 grams
Anti-Skating Force	0 ~ 3.0 grams
Maximum Tracking Error	0.20° / cm
Average Tracking Error	0.07° / cm

GENERAL

Power Requirements	120 V AC 60 Hz
Power Consumption	5 Watts
Dimensions:	
Width	18-1/4 inches (464 mm)
Height	5-5/8 inches (149 mm)
Depth	14-9/16 inches (370 mm)
Weight	17.16 lbs (7.8 kg)

FOR EUROPEAN MODEL ONLY

Drive System	Direct Drive System
Drive Motor Type	Quartz Locked DC Servo
Speed	33-1/3, 45 rpm.
Rumble	
NAB RRL	69 dB
DIN B WTD	75 dB
Hunt Pick-up	60 dB
Wow and Flutter	
NAB WRMS	0.025%
DIN 45 507	0.05%
Tone Arm Length	8-5/8" (219 mm)
Overhang	23/32" (18 mm)
Tracking Force	0 ~ 3 g
Anti Skating Force	0 ~ 3 g
Tracking Error	-2.94° ~ +0.61°
Platter Diameter	12-5/8" (320 mm)
Platter Weight	3.5 lbs (1600 g)

GENERAL

Power Requirements	220 V/AC, 50 Hz
(This unit can be converted by a qualified technician to operate on 110/220/240 V, 50 Hz)	
Power Consumption	5 W
Dimensions	
Width	18-1/4" (464 mm)
Height	5-7/8" (149 mm)
Depth	14-9/16" (370 mm)
Weight	
Unit alone	17.1 lbs (7.8 kg)
Packed for Shipment	21.6 lbs (9.8 kg)