

# Service Manual

CC4300 /A1B/F1B/N1B/U1B

5 Disc CD Changer

CC4300

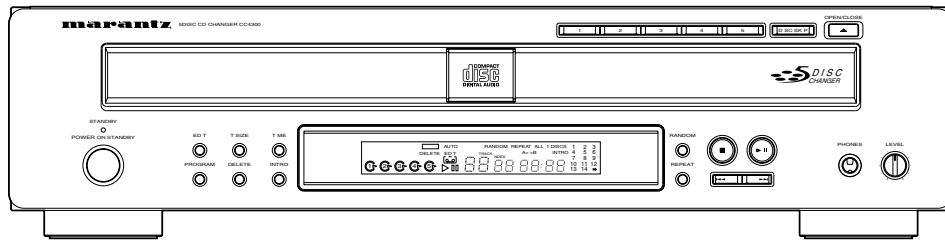

COMPACT  
disc  
DIGITAL AUDIO

## TABLE OF CONTENTS

SECTION	PAGE
1. TECHNICAL SPECIFICATIONS .....	1
2. SERVICE MODE .....	1
3. TAKING THE DISC OUT OF EMERGENCY .....	2
4. CAUTIONS IN ASSEMBLING AND DISASSEMBLING .....	3
5. WIRING DIAGRAM .....	4
6. BLOCK DIAGRAM .....	5
7. SCHEMATIC DIAGRAM .....	7
8. PARTS LOCATION .....	9
9. IC DATA .....	17
10. EXPLODED VIEW AND PARTS LIST .....	21
11. ELECTRICAL PARTS LIST .....	27

Please use this service manual with referring to the user guide ( D.F.U. ) without fail.

修理の際は、必ず取扱説明書を準備し操作方法を確認の上作業を行ってください。

# marantz®

## CC4300

## MARANTZ DESIGN AND SERVICE

Using superior design and selected high grade components, **MARANTZ** company has created the ultimate in stereo sound. Only original **MARANTZ** parts can insure that your **MARANTZ** product will continue to perform to the specifications for which it is famous.

Parts for your **MARANTZ** equipment are generally available to our National Marantz Subsidiary or Agent.

### ORDERING PARTS :

Parts can be ordered either by mail or by Fax.. In both cases, the correct part number has to be specified.

The following information must be supplied to eliminate delays in processing your order :

1. Complete address
2. Complete part numbers and quantities required
3. Description of parts
4. Model number for which part is required
5. Way of shipment
6. Signature : any order form or Fax. must be signed, otherwise such part order will be considered as null and void.

#### USA

**MARANTZ AMERICA, INC**  
1100 MAPLEWOOD DRIVE  
ITASCA, IL. 60143  
USA  
PHONE : 630 - 741 - 0300  
FAX : 630 - 741 - 0301

#### EUROPE / TRADING

**MARANTZ EUROPE B.V.**  
P. O. BOX 8744, BUILD NG SILVERPOINT  
BEEMDSTRAAT 11, 5653 MA EINDHOVEN  
THE NETHERLANDS  
PHONE : +31 - 40 - 2507844  
FAX : +31 - 40 - 2507860

#### CANADA

**LENBROOK INDUSTRIES LIMITED**  
633 GRANITE COURT,  
PICKERING, ONTARIO L1W 3K1  
CANADA  
PHONE : 905 - 831 - 6333  
FAX : 905 - 831 - 6936

#### PROFESSIONAL AMERICAS

**SUPERSCOPE TECHNOLOGIES, INC.**  
MARANTZ PROFESSIONAL PRODUCTS  
2640 WHITE OAK CIRCLE, SUITE A  
AURORA, ILLINOIS 60504 USA  
PHONE : 630 - 820 - 4800  
FAX : 630 - 820 - 8103

#### PROFESSIONAL AUSTRALIA

**TECHNICAL AUDIO GROUP PTY, LTD**  
558 DARLING STREET,  
BALMAIN, NSW 2041,  
AUSTRALIA  
PHONE : 61 - 2 - 9810 - 5300  
FAX : 61 - 2 - 9810 - 5355

#### PROFESSIONAL HONG KONG

**Jolly ProAudio Broadcast Engineering Ltd.**  
UNIT 2, 10F, WAH HUNG CENTRE,  
41 HUNG TO ROAD, KWUN TONG, KLN.,  
HONG KONG  
PHONE : 852 - 21913660  
FAX : 852 - 21913990

#### AUSTRALIA

**QualiFi Pty Ltd,**  
24 LIONEL ROAD,  
MT. WAVERLEY VIC 3149  
AUSTRALIA  
PHONE : +61 - (0)3 - 9543 - 1522  
FAX : +61 - (0)3 - 9543 - 3677

#### THAILAND

**MRZ STANDARD CO., LTD**  
746 - 754 MAHACHAI ROAD.,  
WANGBURAPAPIROM, PHRANAKORN,  
BANGKOK, 10200 THAILAND  
PHONE : +66 - 2 - 222 9181  
FAX : +66 - 2 - 224 6795

#### SINGAPORE

**WO KEE HONG DISTRIBUTION PTE LTD**  
130 JOO SENG ROAD  
#03-02 OLIVINE BUILDING  
SINGAPORE 368357  
PHONE : +65 6858 5535 / +65 6381 8621  
FAX : +65 6858 6078

#### NEW ZEALAND

**WILDASH AUDIO SYSTEMS NZ**  
14 MALVERN ROAD MT ALBERT  
AUCKLAND NEW ZEALAND  
PHONE : +64 - 9 - 8451958  
FAX : +64 - 9 - 8463554

#### TAIWAN

**PAI- YUING CO., LTD.**  
6 TH FL NO, 148 SUNG KIANG ROAD,  
TAIPEI, 10429, TAIWAN R.O.C.  
PHONE : +886 - 2 - 25221304  
FAX : +886 - 2 - 25630415

#### MALAYSIA

**WO KEE HONG ELECTRONICS SDN. BHD.**  
SUITE 8.1, LEVEL 8, MENARA GENESIS,  
NO. 33, JALAN SULTAN ISMAIL,  
50250 KUALA LUMPUR, MALAYSIA  
PHONE : +60 3 - 21457677  
FAX : +60 3 - 21458180

#### JAPAN *Technical*

**MARANTZ JAPAN, INC.**  
35- 1, 7- CHOME, SAGAMIONO  
SAGAMIHARA - SHI, KANAGAWA  
JAPAN 228-8505  
PHONE : +81 42 748 1013  
FAX : +81 42 741 9190

#### 日本マランツ株式会社

本社 〒228-8505  
神奈川県相模原市相模大野7-35-1  
営業本部 〒150-0022  
東京都渋谷区恵比寿南1-11-9

#### KOREA

**MK ENTERPRISES LTD.**  
ROOM 604/605, ELECTRO-OFFICETEL, 16-58,  
3GA, HANGANG-RO, YONGSAN-KU, SEOUL  
KOREA  
PHONE : +822 - 3232 - 155  
FAX : +822 - 3232 - 154

### SHOCK, FIRE HAZARD SERVICE TEST :

**CAUTION :** After servicing this appliance and prior to returning to customer, measure the resistance between either primary AC cord connector pins ( with unit NOT connected to AC mains and its Power switch ON ), and the face or Front Panel of product and controls and chassis bottom.

Any resistance measurement less than 1 Megohms should cause unit to be repaired or corrected before AC power is applied, and verified before it is return to the user/customer.

Ref. UL Standard No. 1492.

In case of difficulties, do not hesitate to contact the Technical Department at above mentioned address.

# 1. TECHNICAL SPECIFICATIONS

**SYSTEM** ..... Compact Disc Digital Audio

## TYPICAL AUDIO PERFORMANCES

Number of channels ..... 2  
Frequency response ..... 20~20,000 Hz  $\pm$ 0.5 dB  
Signal to noise ratio, A Wtd ..... 105 dB  
Dynamic range ..... 95 dB  
Total harmonic distortion, 1 kHz ..... 0.005 %  
Wow and flutter ..... Quartz crystal precision  
Audio output level ..... 2 V RMS

## Digital output

Optical ..... -19 dBm  
Coaxial ..... 0.5 Vp-p (75 $\Omega$ )

## OPTICAL READOUT SYSTEM

Laser ..... Semiconductor AlGaAs  
Wavelength ..... 780 nm

## SIGNAL FORMAT

Sampling Frequency ..... 44.1 kHz  
D/A Conversion ..... 1 bit P.L.M. D/A Conversion  
Oversampling ..... 8 times

## GENERAL

Power supply  
A Version ..... AC 240 V, 50 Hz  
F Version ..... AC 100 V, 50/60 Hz  
N Version ..... AC 230 V, 50 Hz  
U Version ..... AC 120 V, 60 Hz  
Power consumption ..... 12 W  
Dimensions (W x H x D) ..... 17-5/16 x 4-7/16 x 15-1/2 inches (440 x 113 x 393 mm)  
Weight (NET) ..... 12.8 lbs (5.8 kg)

# 2. SERVICE MODE

1. While Mains cord is disconnected , press **EDIT** button on the unit and in the Mains cord.
2. Version number of the micom software is displayed on the FL " \* \* \* - \* \* \* "
3. Press **DISC SKIP** button then FL display shows all segments and the next one segments will turn on as interval of 0.5 second one by one.
4. Disconnect Mains cord to quit service mode.

### 3. TAKING THE DISC OUT OF EMERGENCY

1. Remove 6 screws on the top cover and remove the top cover.
2. Turn the gear to see from the hole of the square to the direction shown with your finger and disc tray will opened.

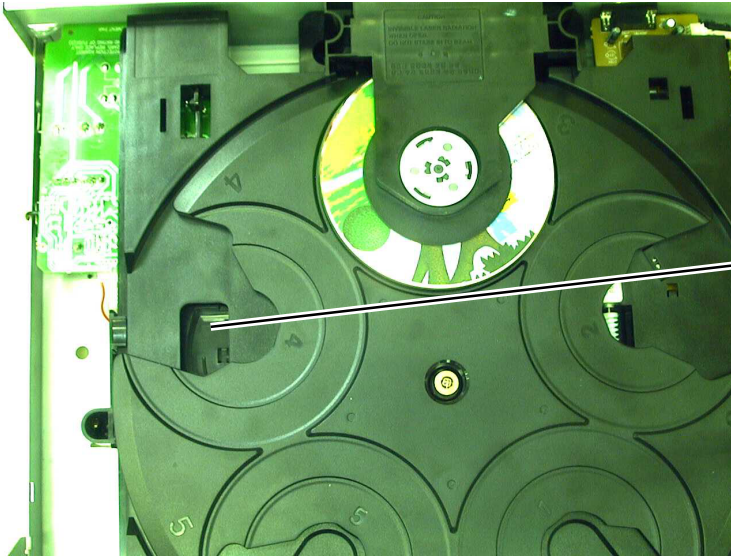

The hole of the square

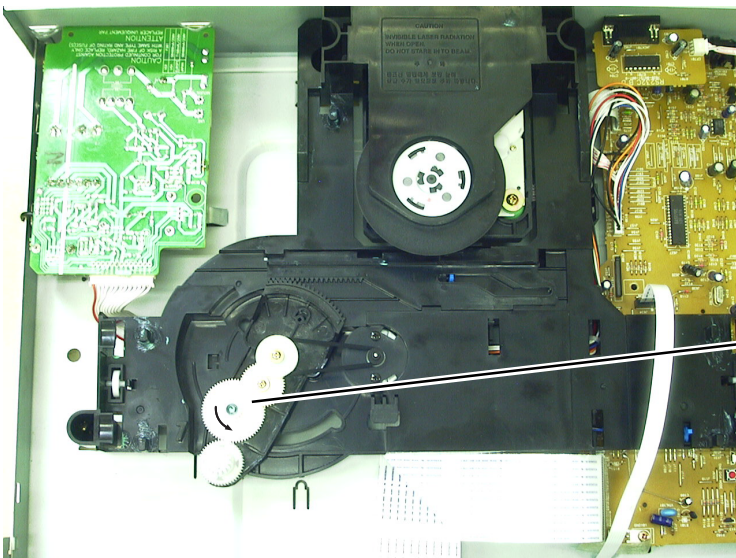

Turn the gear

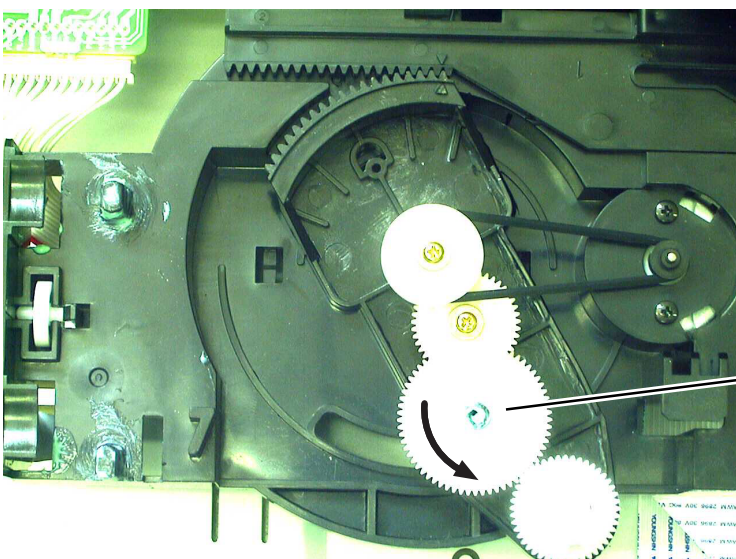

The gear

#### 4. CAUTIONS IN ASSEMBLING AND DISASSEMBLING

##### REMOVE DISC TRAY

1. When removing the Disc tray, disconnect the wires at the rear side and a hook is bent in the arrow direction. can be removed when Tray is pulled to the front.
2. The arrow of gear is checked, and Tray is inserted.

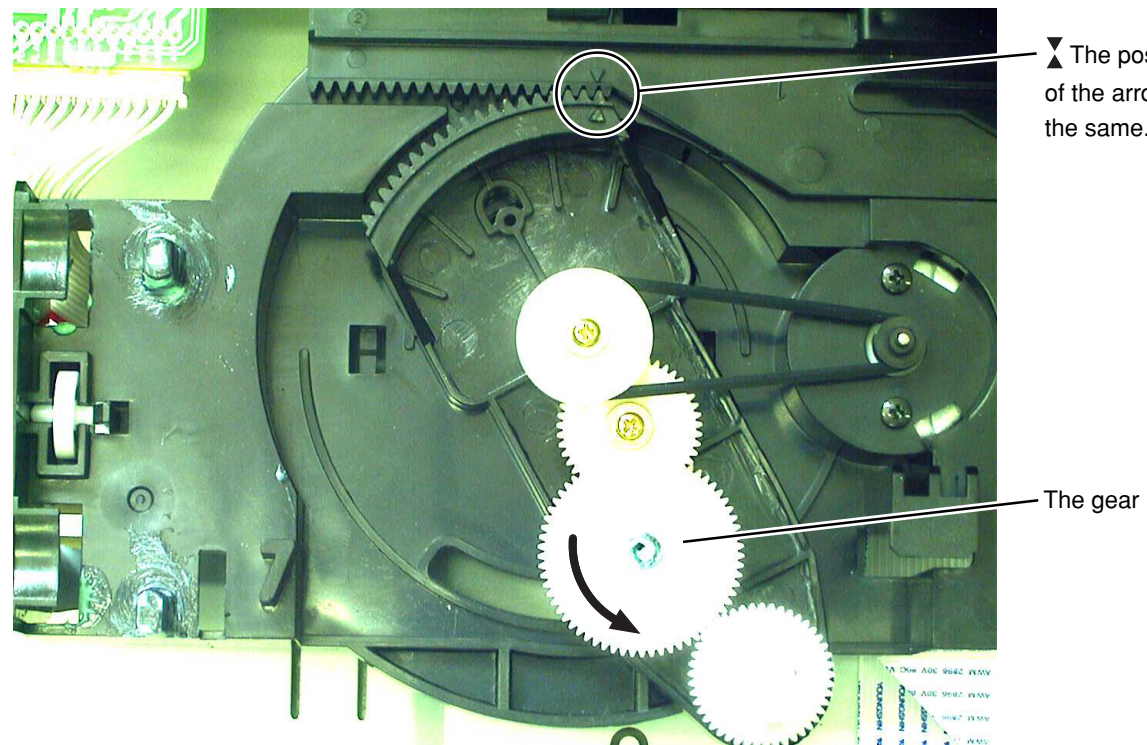

#### 5. WIRING DIAGRAM

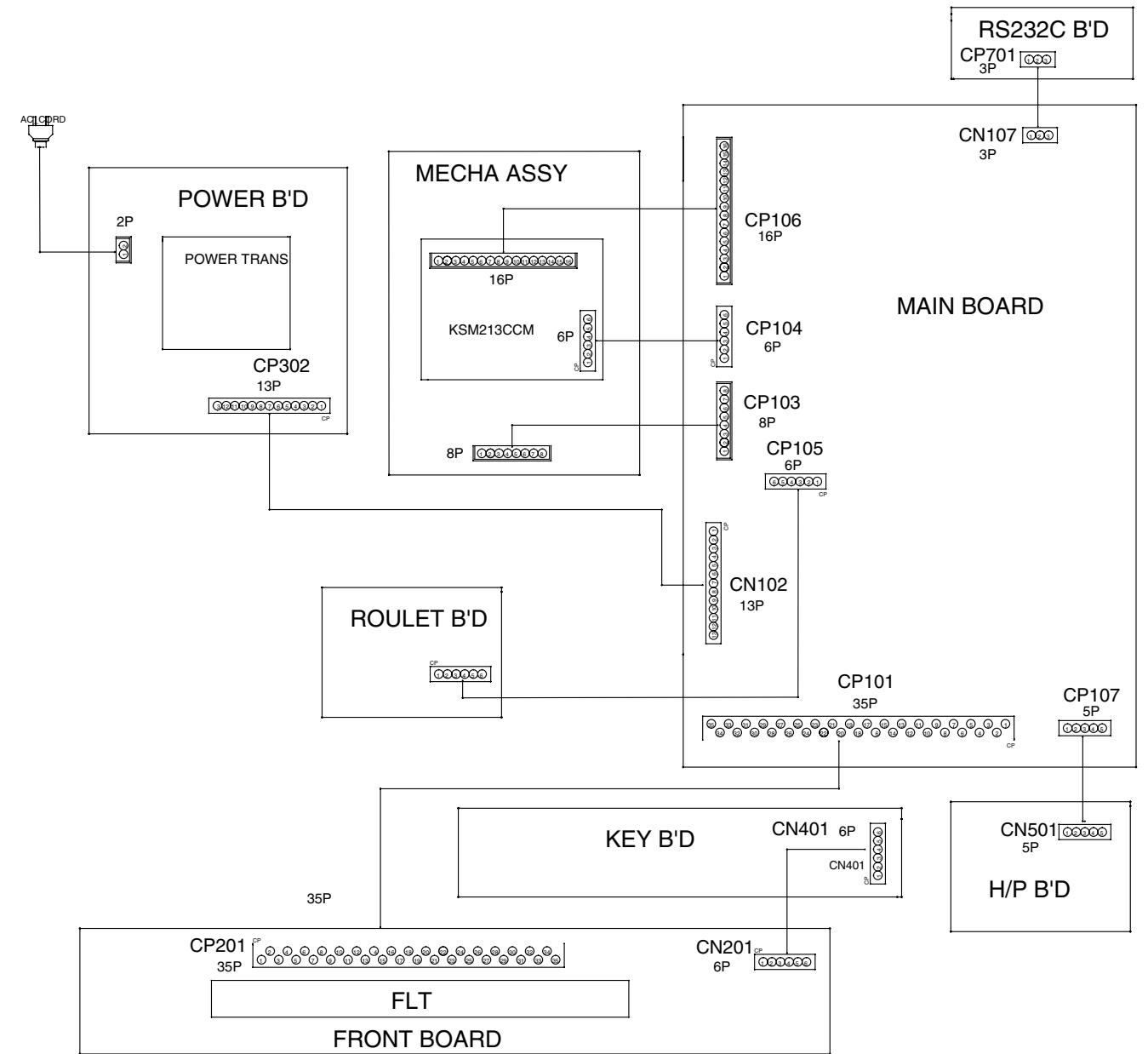

6. BLOCK DIAGRAM

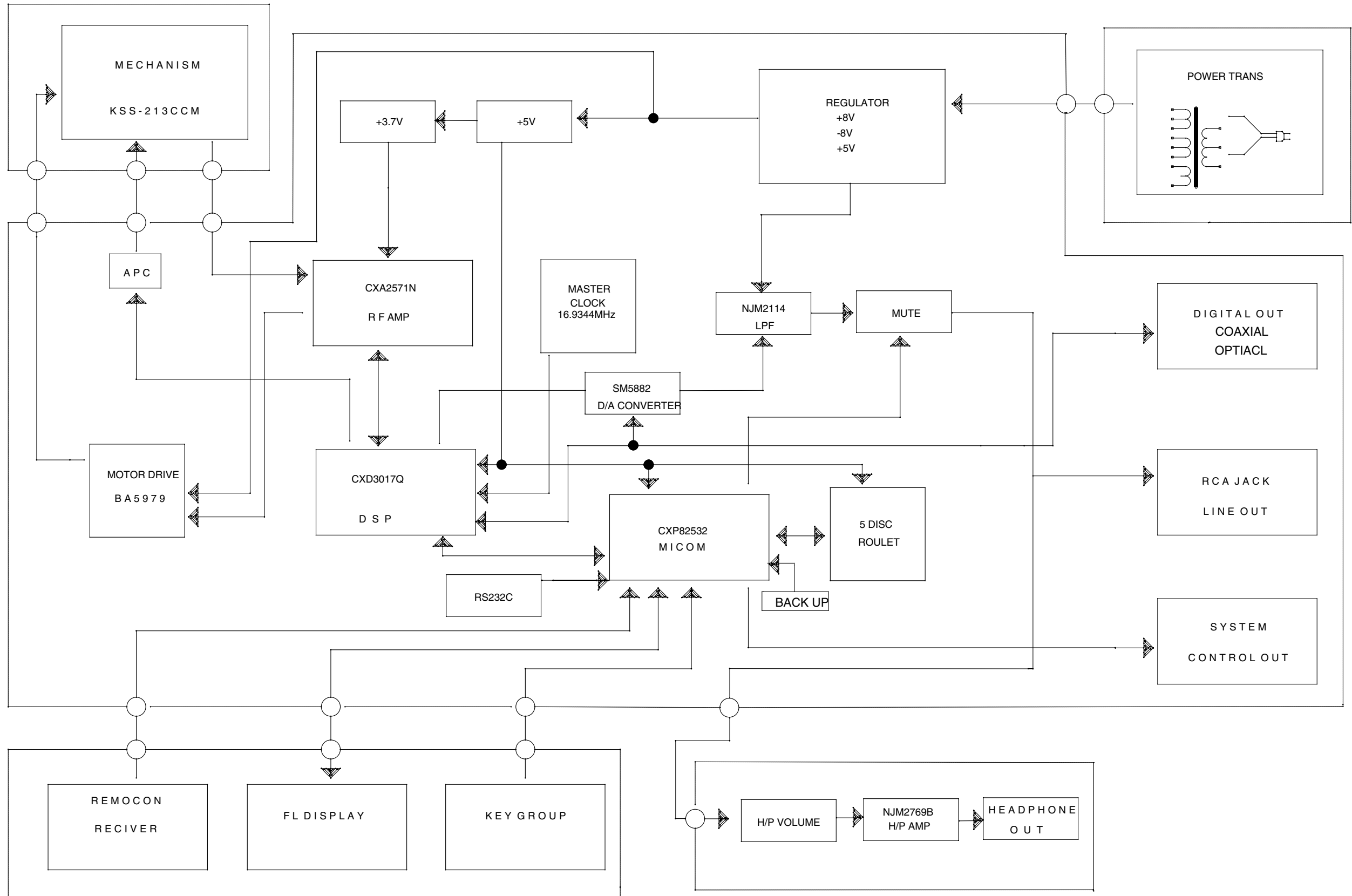

7. SCHEMATIC DIAGRAM

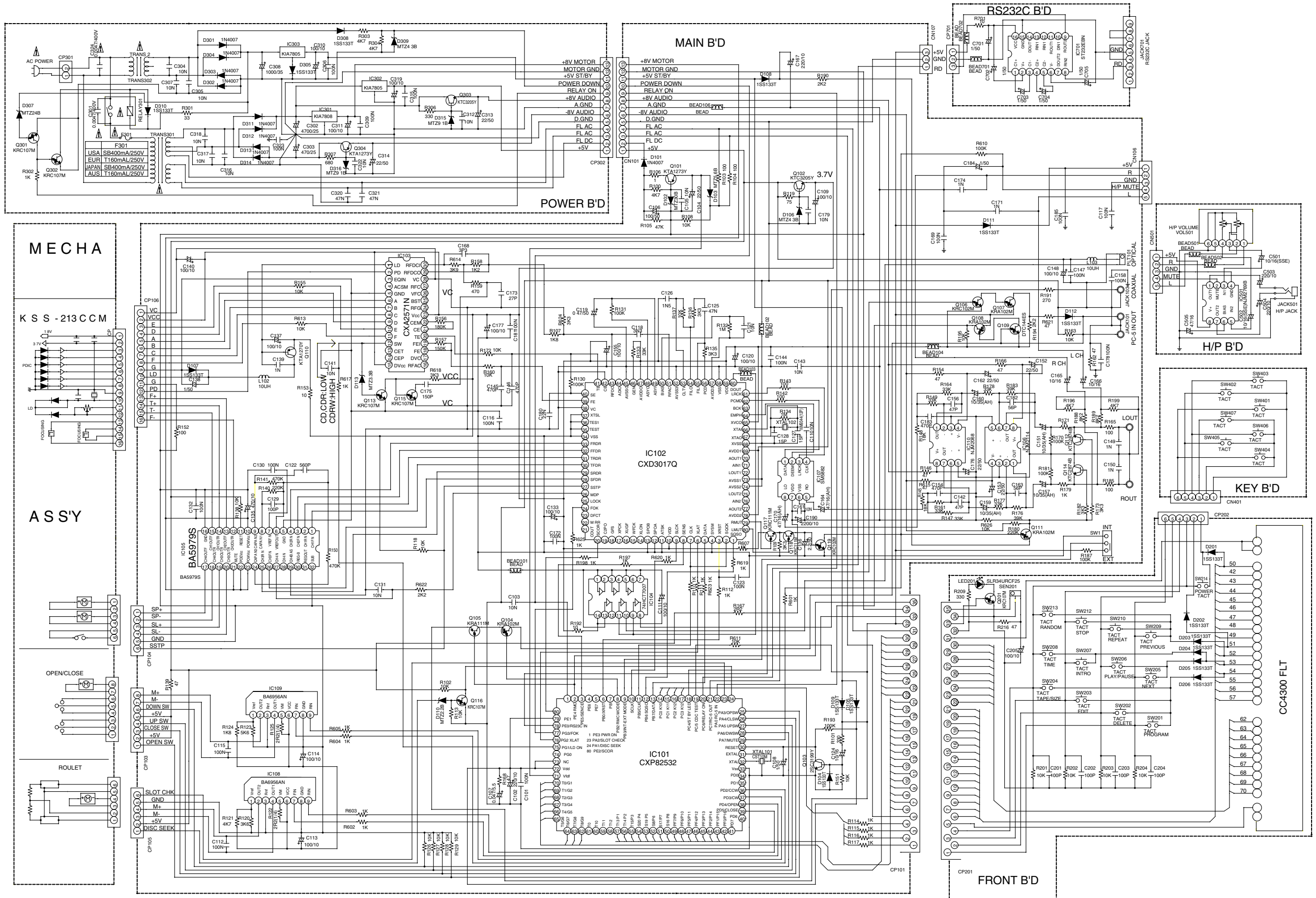

8. PARTS LOCATION

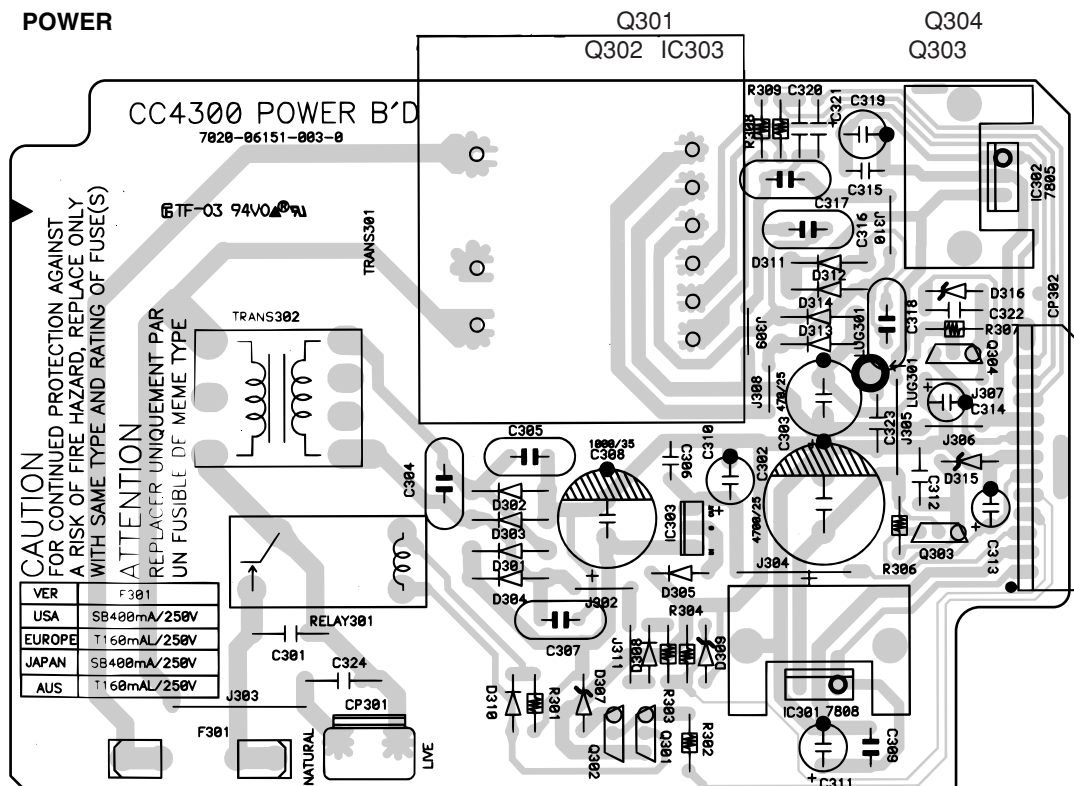
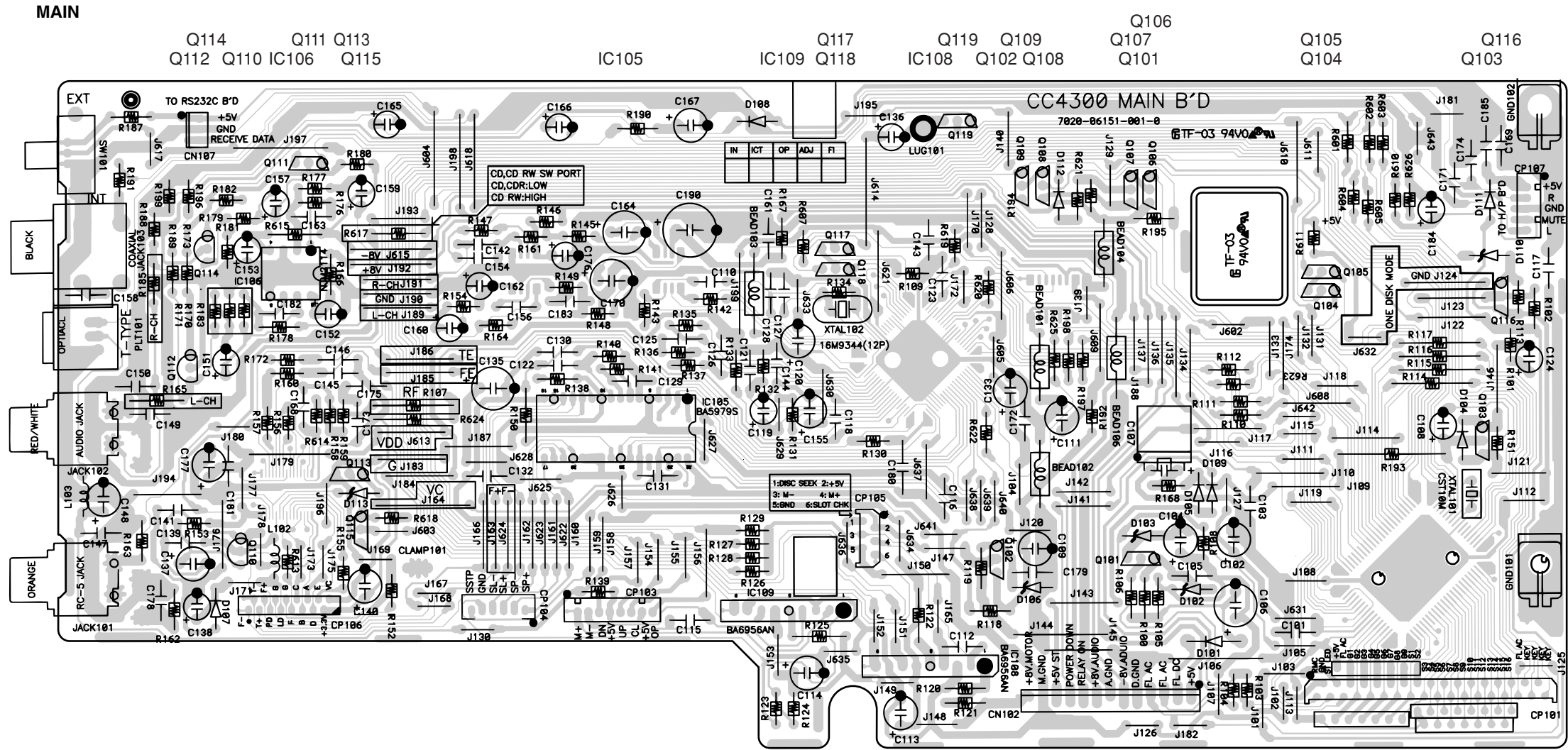



MAIN

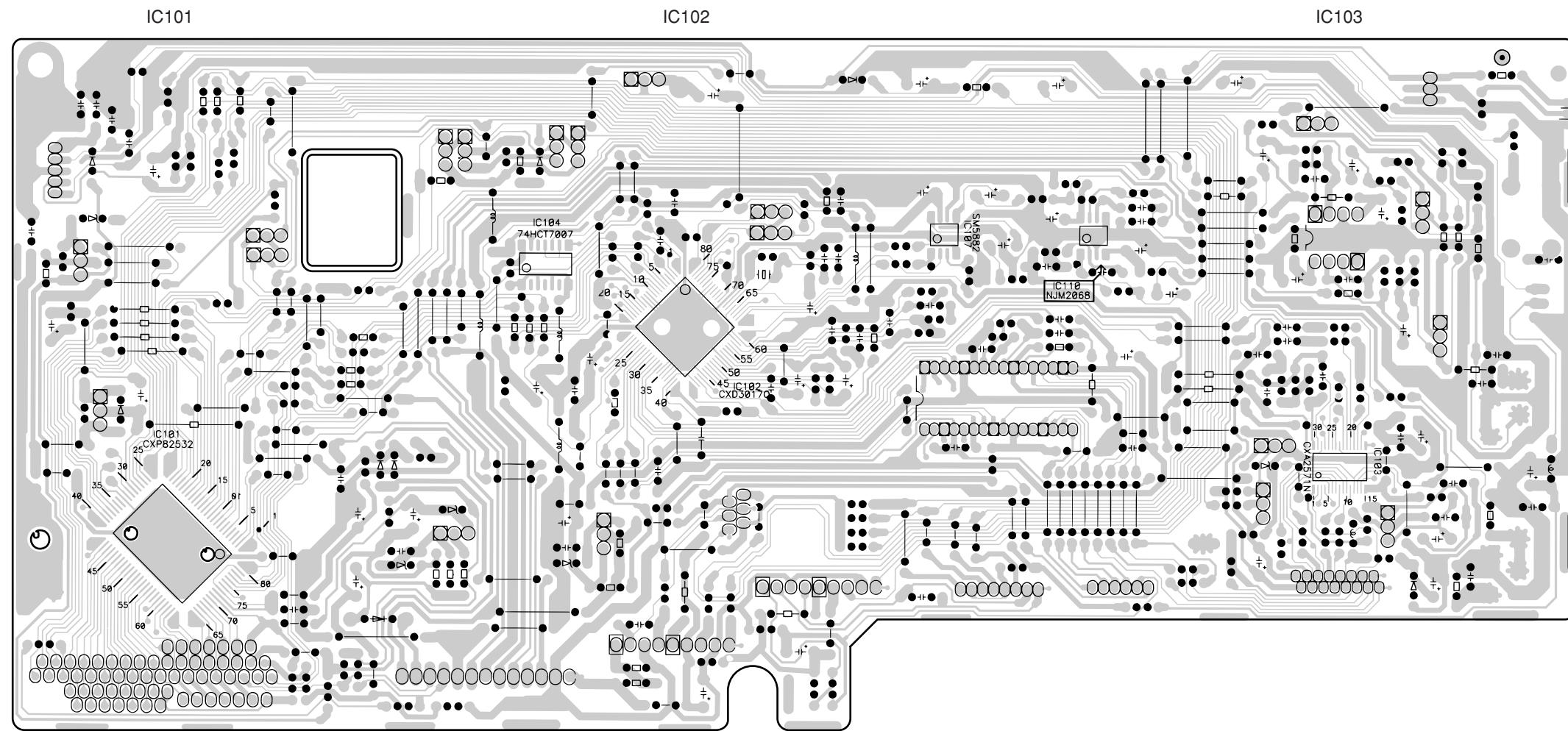

POWER

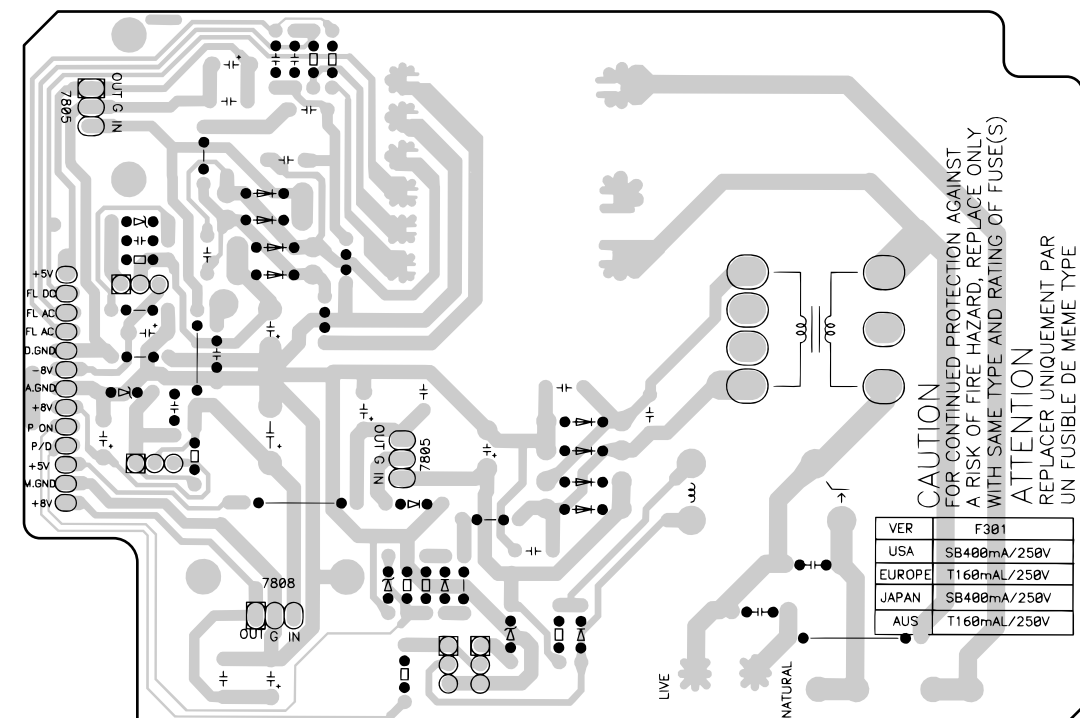

RS232C

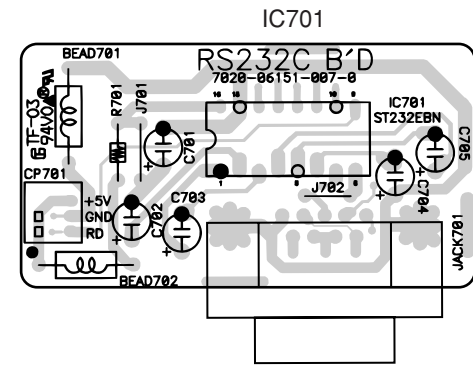

H/P (HEAD/PHONES)

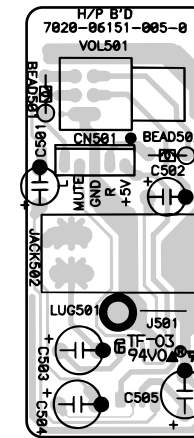

KEY

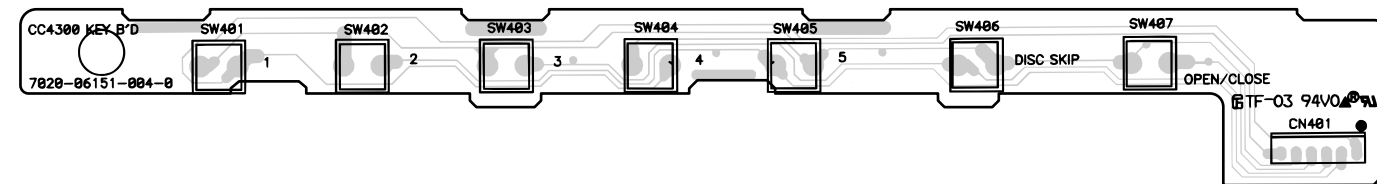

FRONT

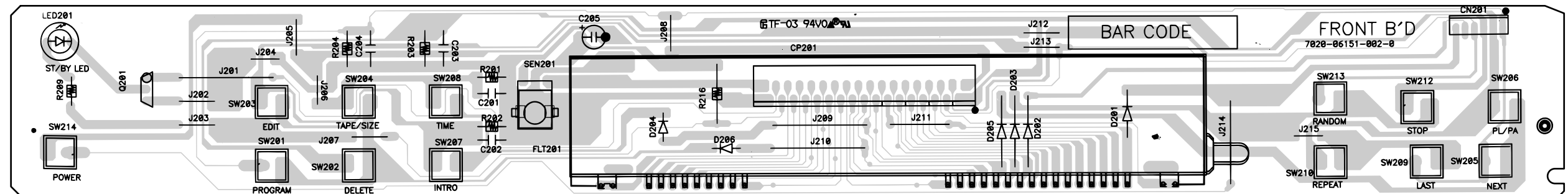

H/P (HEAD/PHONES)

IC501

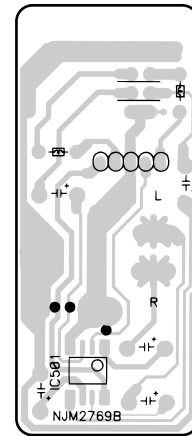

RS232C

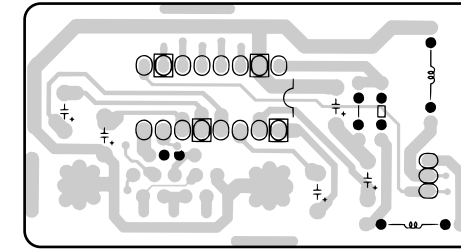

KEY

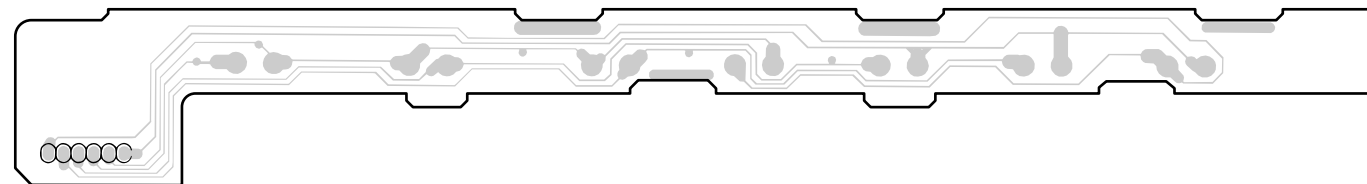

FRONT

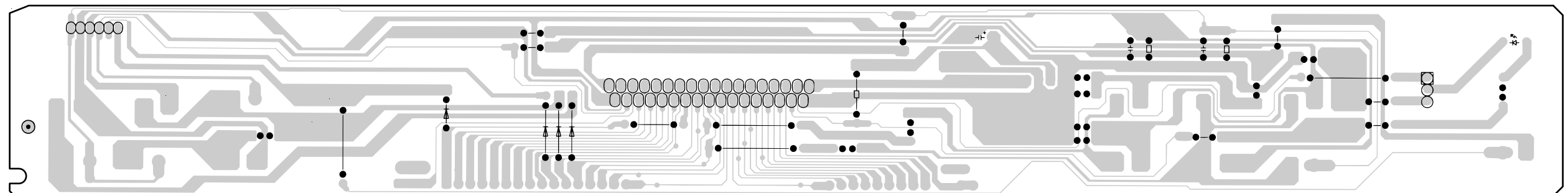

## 9. IC DATA

IC101 : CXP82532

### PIN OPERATION

PIN NO	PIN NAME	operation	description	ASSIGN
1	POWER DOWN	Input for power down		I
2	RMC	Input for remocan data		I
3	SENSE	Input for SENS of CXD3017Q CD DSP		I
4	NC	NO CONNECTION		
5	NC	NO CONNECTION		
6	XRST	Output for XRST of CXD3017Q CD DSP		O
7	NC	NO CONNECTION		
8	RMC MODE(INT/EXT)	Output for RC-5 on/off		O
9	RC-5 int/ext	Input for RC-5 int/ext		I
10	SCLK	Output for SCLK of CXD3017Q CD DSP		O
11	CLK	Output for CLK of CXD3017Q CD DSP		O
12	SOSO	Input for SOSO of CXD3017Q CD DSP		I
13	DATA	Output for DATA of CXD3017Q CD DSP		O
14	KEY INPUT	Data input key scan		I
15	KEY INPUT	Data input key scan		I
16	KEY INPUT	Data input key scan		I
17	KEY INPUT	Data input key scan		I
18	ST/BY LED	Output to drive SYBY LED(REDF)	ACTIVE "HIGH"	O
19	ONE DISK MODE	Input for ONE DISK MODE(TEST MODE)		I
20	POWER ON	Output for relay on	ACTIVE "HIGH"	O
21	RC-5 OUT	Output for RC-5		O
22	RC-5 IN	Input for RC-5		I
23	SLOT CHECK	Input for SLOT CHECK of RULET.		I
24	DISC SEEK	Input for DISC SEEK of RULET.		I
25	OPEN SW	Input for detecting "TRAY OPEN SW" condition		I
26	CLOSE SW	Input for detecting "TRAY CLOSE SW" condition		I
27	UP SW	Input for detecting "UP SW" condition		I
28	DOWN SW	Input for detecting "DOWN SW" condition		I
29	MUTE	Output for MUTE	ACTIVE "LOW"	O
30	RESET	Input for RESET		I
31	EXTAL	Input for 10MHz crystal oscillator.		I
32	XTAL	Output for 10MHz crystal oscillator.		O
33	VSS	Ground		
34	NC	NO CONNECTION		
35	NC	NO CONNECTION		
36	ROLET CCW	Output for ROULET CCW.		O
37	ROLET CW	Output for ROULET CW.		O
38	TRAY CLOSE	Output for TRAY CLOSE.		O
39	TRAY OPEN	Output for TRAY OPEN.		O
40	NC	NO CONNECTION		
41	NC	NO CONNECTION		
42	SEG16	Out for FLT SEGMENT16.		O
43	SEG15	Out for FLT SEGMENT15.		O
44	SEG14	Out for FLT SEGMENT14.		O
45	SEG13	Out for FLT SEGMENT13.		O
46	SEG12	Out for FLT SEGMENT12.		O
47	SEG11	Out for FLT SEGMENT11.		O
48	SEG10	Out for FLT SEGMENT10.		O
49	SEG9	Out for FLT SEGMENT9.		O
50	SEG8	Out for FLT SEGMENT8.		O
51	SEG7	Out for FLT SEGMENT7.		O
52	SEG6	Out for FLT SEGMENT6.		O
53	SEG5	Out for FLT SEGMENT5.		O
54	SEG4	Out for FLT SEGMENT4.		O
55	SEG3	Out for FLT SEGMENT3.		O
56	SEG2	Out for FLT SEGMENT2.		O
57	SEG1	Out for FLT SEGMENT1.		O
58	NC	NO CONNECTION		
59	NC	NO CONNECTION		
60	NC	NO CONNECTION		
61	NC	NO CONNECTION		
62	GRID9	Out for FLT GRID9		O
63	GRID8	Out for FLT GRID8		O
64	GRID7	Out for FLT GRID7		O
65	GRID6	Out for FLT GRID6		O
66	GRID5	Out for FLT GRID5		O
67	GRID4	Out for FLT GRID4		O
68	GRID3	Out for FLT GRID3		O
69	GRID2	Out for FLT GRID2		O
70	GRID1	Out for FLT GRID1		O
71	VDFD	VDFD -30V		
72	VDD	VDD +5V		
73	VDD	VDD +5V		
74	NC	NO CONNECTION		
75	LD ON	Output for LD on	CD CDR:"LOW" , CD RW:"HIG"	O
76	XLAT	Output for LATCH of CXD3017 CD DSP		O
77	FOK	Input for FOK of CXD3017Q CD DSP		I
78	RS232C IN	Input for RS232C DATA.		I
79	VDD	VDD +5V		
80	SCOR	Input for SCOR of CXD3017Q CD DSP		I

### Block Diagram

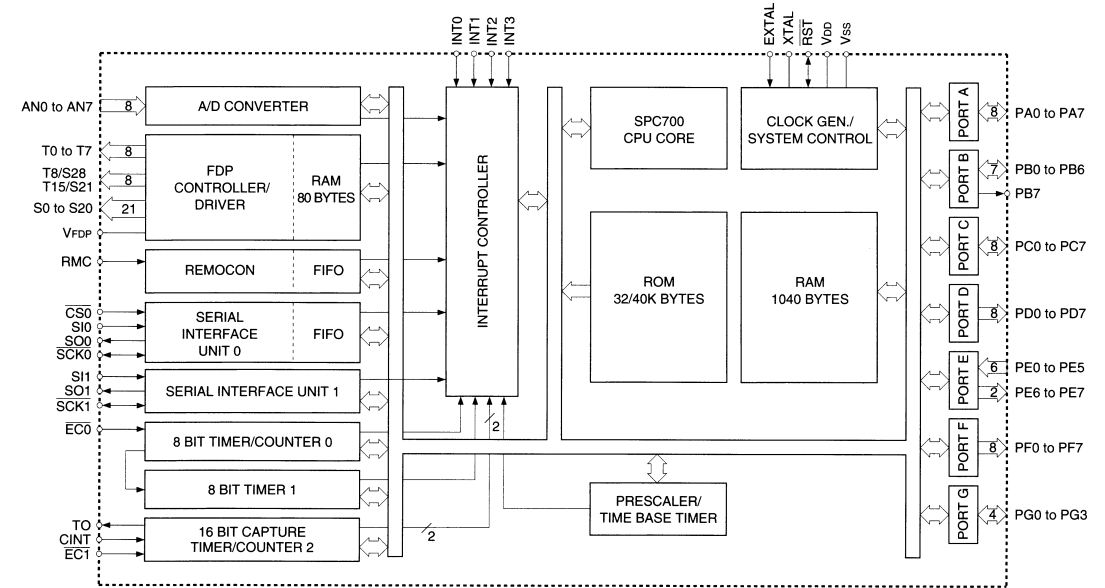

IC103 : CXA2571N

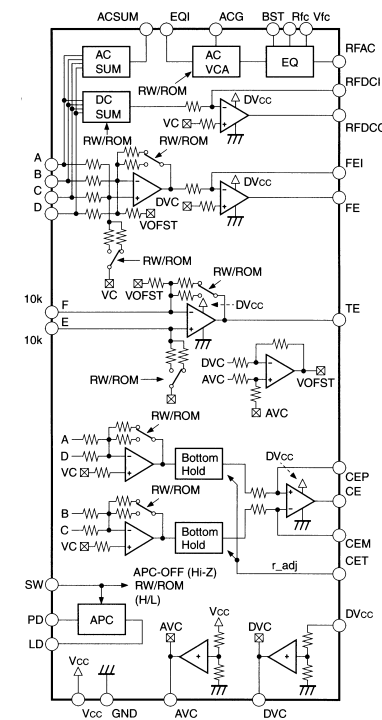

### Pin Description

Pin NO.	Symbol	I/O	Description
1	LD	Out	APC amplifier output.
2	PD	In	APC amplifier input.
3	EQ_IN	In	RFAC system VCA block and EQ block input.
4	AC_SUM	Out	RFAC system RF SUM output.
5	GND	In	Ground.
6	A	In	A signal input.
7	B	In	B signal input.
8	C	In	C signal input.
9	D	In	D signal input.
10	E	In	E signal input.
11	F	In	F signal input.
12	SW	In	Mode switching signal input.
13	CET	In	CE system hold time constant adjustment.
14	CEP	—	CE amplifier non-inverted input.
15	DVcc	In	DVcc.
16	RFAC	Out	RFAC signal output.
17	DVC	Out	DVC output.
18	FE	Out	Focus error signal output.
19	FEI	—	FE amplifier virtual ground.
20	TE	Out	Tracking error signal output.
21	CE	Out	Center error signal output.
22	CEM	—	CE amplifier virtual ground.
23	Vcc	In	Vcc.
24	RFQ	In	RFAC system VCA block low-frequency gain adjustment.
25	BST	In	EQ boost amount adjustment range.
26	VFC	In	EQ cut-off frequency adjustment.
27	RFC	In	EQ cut-off frequency adjustment.
28	VC	Out	VC voltage output.
29	RFDCO	Out	RFDC signal output.
30	RFDCI	—	RFDC amplifier virtual ground.

IC102 : CXD3017Q

Block Diagram

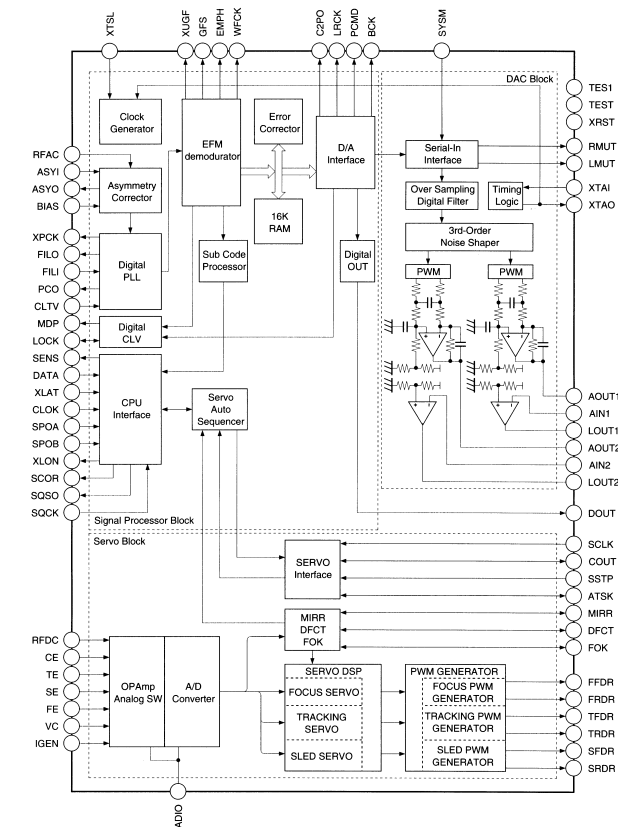

Pin Description

Pin No.	Symbol	I/O	Output values	Description
1	SGSO	O	1, 0	Sub Q 80-bit, PCM peak and level data outputs. CD TEXT data output.
2	SQCK	I		SQSO readout clock input.
3	XRST	I		System reset. Reset when low.
4	YSYM	I		Mute input. Muted when high.
5	DATA	I		Serial data input from CPU.
6	XLAT	I		Latch input from CPU. Serial data is latched at the falling edge.
7	CLOCK	I		Serial data transfer clock input from CPU.
8	SENS	O	1, 0	SENS output to CPU.
9	SCLK	I		SENS serial data readout clock input.
10	V <sub>DD</sub>	—	—	Digital power supply.
11	ATSK	I/O	1, 0	Anti-shock input/output.
12	SPOA	I		Microcomputer extension interface (input A)
13	SPOB	I		Microcomputer extension interface (input B)
14	XLON	O	1, 0	Microcomputer extension interface (output)
15	WFCK	O	1, 0	WFCK output.
16	XUGF	O	1, 0	XUGF output. MINT1 or RFCK is output by switching with the command.
17	XPCK	O	1, 0	XPCK output. MNT0 is output by switching with the command.
18	GFS	O	1, 0	GFS output. MNT3 or XROF is output by switching with the command.
19	C2PO	O	1, 0	C2PO output. GTOP is output by switching with the command.
20	SCOR	O	1, 0	Outputs a high signal when either subcode sync S0 or S1 is detected.
21	COUT	I/O	1, 0	Track count signal input/output.
22	MIRR	I/O	1, 0	Mirror signal input/output.
23	DFCT	I/O	1, 0	Defect signal input/output.
24	FOK	I/O	1, 0	Focus OK signal input/output.
25	LOCK	I/O	1, 0	GFS is sampled at 460Hz; when GFS is high, this pin outputs a high signal. If GFS is low eight consecutive samples, this pin outputs low. Or input when LKIN = 1.
26	MDP	O	1, Z, 0	Spindle motor servo control output.
27	SSTP	I		Disc innermost track detection signal input.
28	SFDR	O	1, 0	Sted drive output.
29	SRDR	O	1, 0	Sted drive output.
30	TFDR	O	1, 0	Tracking drive output.
31	TRDR	O	1, 0	Tracking drive output.
32	FFDR	O	1, 0	Focus drive output.
33	FRDR	O	1, 0	Focus drive output.
34	V <sub>SS</sub>	—	—	Digital GND.

Pin No.	Symbol	I/O	Output values	Description
35	TEST	I		Test pin. Normally, GND.
36	TES1	I		Test pin. Normally, GND.
37	XTSL	I		Crystal selection input. Low when the crystal is 16.9344MHz; high when the crystal is 33.8688MHz.
38	VC	I		Center voltage input.
39	FE	I		Focus error signal input.
40	SE	I		Sled error signal input.
41	TE	I		Tracking error signal input.
42	CE	I		Center servo analog input.
43	RFDC	I		RF signal input.
44	ADIO	O	Analog	Test pin. No connected.
45	AV <sub>SS</sub> 0	—	—	Analog GND.
46	IGEN	I		Operational amplifier constant current input.
47	AV <sub>DD</sub> 0	—	—	Analog power supply.
48	ASYO	O	1, 0	EFM full-swing output. (low = V <sub>SS</sub> , high = V <sub>DD</sub> )
49	ASYI	I		Asymmetry comparator voltage input.
50	BIAS	I		Asymmetry circuit constant current input.
51	RFAC	I		EFM signal input.
52	AV <sub>SS</sub> 3	—	—	Analog GND.
53	CLTV	I		Multiplier VCO1 control voltage input.
54	FILO	O	Analog	Master PLL filter output. (slave = digital PLL)
55	FILI	I		Master PLL filter input.
56	PCO	O	1, Z, 0	Master PLL charge pump output.
57	AV <sub>DD</sub> 3	—	—	Analog power supply.
58	V <sub>SS</sub>	—	—	Digital GND.
59	V <sub>DD</sub>	—	—	Digital power supply.
60	DOUT	O	1, 0	Digital Out output.
61	LRCK	O	1, 0	D/A interface. LR clock output f = F <sub>s</sub> .
62	PCMD	O	1, 0	D/A interface. Serial data output. (two's complement, MSB first)
63	BCK	O	1, 0	D/A interface. Bit clock output.
64	EMPH	O	1, 0	Outputs a high signal when the playback disc has emphasis, and a low signal when there is no emphasis.
65	XV <sub>DD</sub>	—	—	Master clock power supply.
66	XTAI	I		Crystal oscillation circuit input. Master clock is externally input from this pin.
67	XTAO	O		Crystal oscillation circuit output.
68	XV <sub>SS</sub>	—	—	Master clock GND.

Pin No.	Symbol	I/O	Output values	Description
69	AV <sub>DD</sub> 1	—	—	Analog power supply.
70	AOUT1	O		L ch analog output.
71	AIN1	I		L ch operational amplifier input.
72	LOUT1	O		L ch LINE output.
73	AV <sub>SS</sub> 1	—	—	Analog GND.
74	AV <sub>SS</sub> 2	—	—	Analog GND.
75	LOUT2	O		R ch LINE output.
76	AIN2	I		R ch operational amplifier input.
77	AOUT2	O		R ch analog output.
78	AV <sub>DD</sub> 2	—	—	Analog power supply.
79	RMUT	O	1, 0	R ch zero detection flag.
80	LMUT	O	1, 0	L ch zero detection flag.

- Notes**
- PCMD is a MSB first, two's complement output.
  - GTOP is used to monitor the frame sync protection status. (High: sync protection window released.)
  - XUGF is the frame sync obtained from the EFM signal, and is negative pulse. It is the signal before sync protection.
  - XPCK is the inverse of the EFM PLL clock. The PLL is designed so that the falling edge and the EFM signal transition point coincide.
  - The GFS signal goes high when the frame sync and the insertion timing match.
  - RFCK is derived from the crystal accuracy, and has a cycle of 136μs.
  - C2PO represents the data error status.
  - XROF is generated when the 16K RAM exceeds the ±4F jitter margin.

Monitor Pin Output Combinations

Command bit	Output data				
MTSL1	MTSL0				
0	0	XUGF	XPCK	GFS	C2PO
0	1	MNT1	MNT0	MNT3	C2PO
1	0	RFCK	XPCK	XROF	GTOP

IC107 : SM5882

PIN DESCRIPTION

Number	Name	I/O	Description
1	DATA	I	Serial data input
2	BCK <sup>1</sup>	I	Bit clock input
	DEEM <sup>2</sup>	I	Deemphasis ON/OFF control (44.1 kHz, ON when HIGH)
3	LRCI	I	Sample rate (fs) clock input. Left-channel input when HIGH, and right-channel input when LOW.
4	CLK	I	External clock input
5	RO	O	Right-channel analog output
6	VSS	—	Ground
7	VDD	—	Supply
8	LO	O	Left-channel analog output

- 3-wire type
- 2-wire type with built-in deemphasis filter

BLOCK DIAGRAM

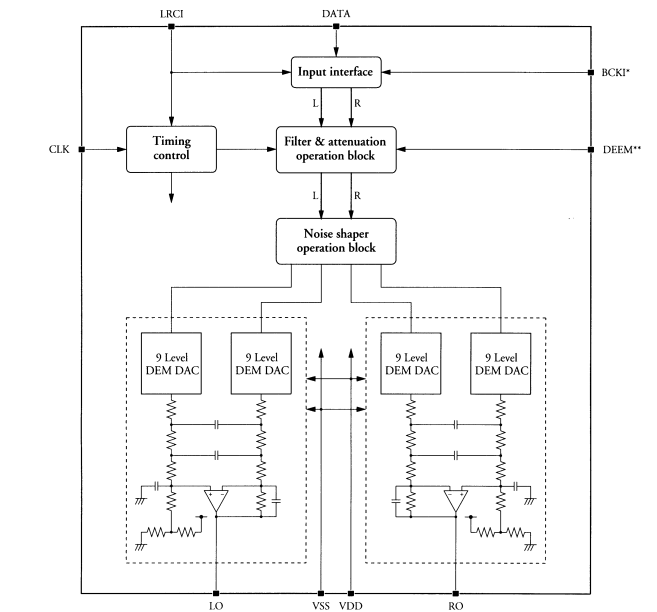

- <sup>1</sup> : Not available for 2-wire input type
- <sup>2</sup> : Not available for 3-wire input type

IC110 : NJM2068

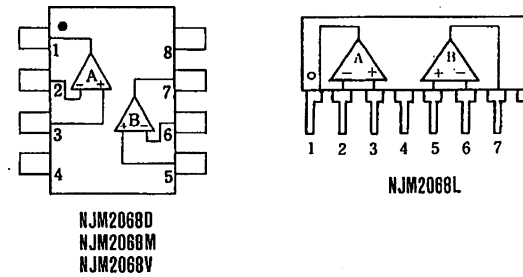

IC501 : NJM2769B

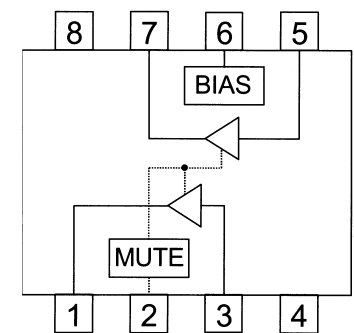

IC701 : ST232EBN

PIN DESCRIPTION

PIN No	SYMBOL	NAME AND FUNCTION
1	C <sub>1+</sub>	Positive Terminal for the first Charge Pump Capacitor
2	V <sub>+</sub>	Doubled Voltage Terminal
3	C <sub>1-</sub>	Negative Terminal for the first Charge Pump Capacitor
4	C <sub>2+</sub>	Positive Terminal for the second Charge Pump Capacitor
5	C <sub>2-</sub>	Negative Terminal for the second Charge Pump Capacitor
6	V <sub>-</sub>	Inverted Voltage Terminal
7	T <sub>2OUT</sub>	Second Transmitter Output Voltage
8	R <sub>2IN</sub>	Second Receiver Input Voltage
9	R <sub>2OUT</sub>	Second Receiver Output Voltage
10	T <sub>2IN</sub>	Second Transmitter Input Voltage
11	T <sub>1IN</sub>	First Transmitter Input Voltage
12	R <sub>1OUT</sub>	First Receiver Output Voltage
13	R <sub>1IN</sub>	First Receiver Input Voltage
14	T <sub>1OUT</sub>	First Transmitter Output Voltage
15	GND	Ground
16	V <sub>CC</sub>	Supply Voltage

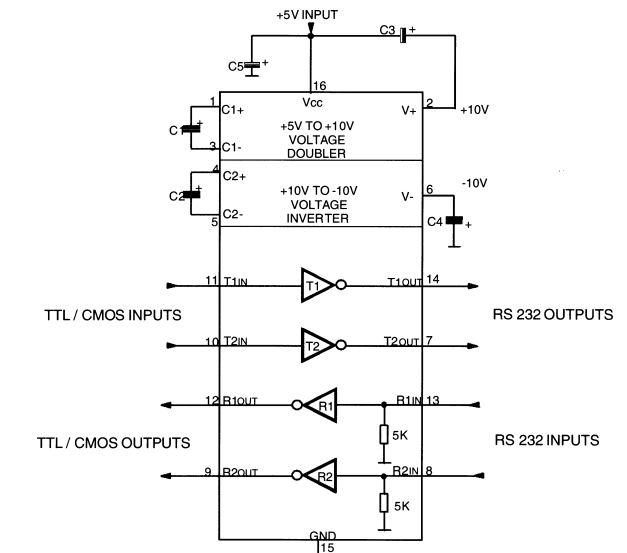

10. EXPLODED VIEW AND PARTS LIST

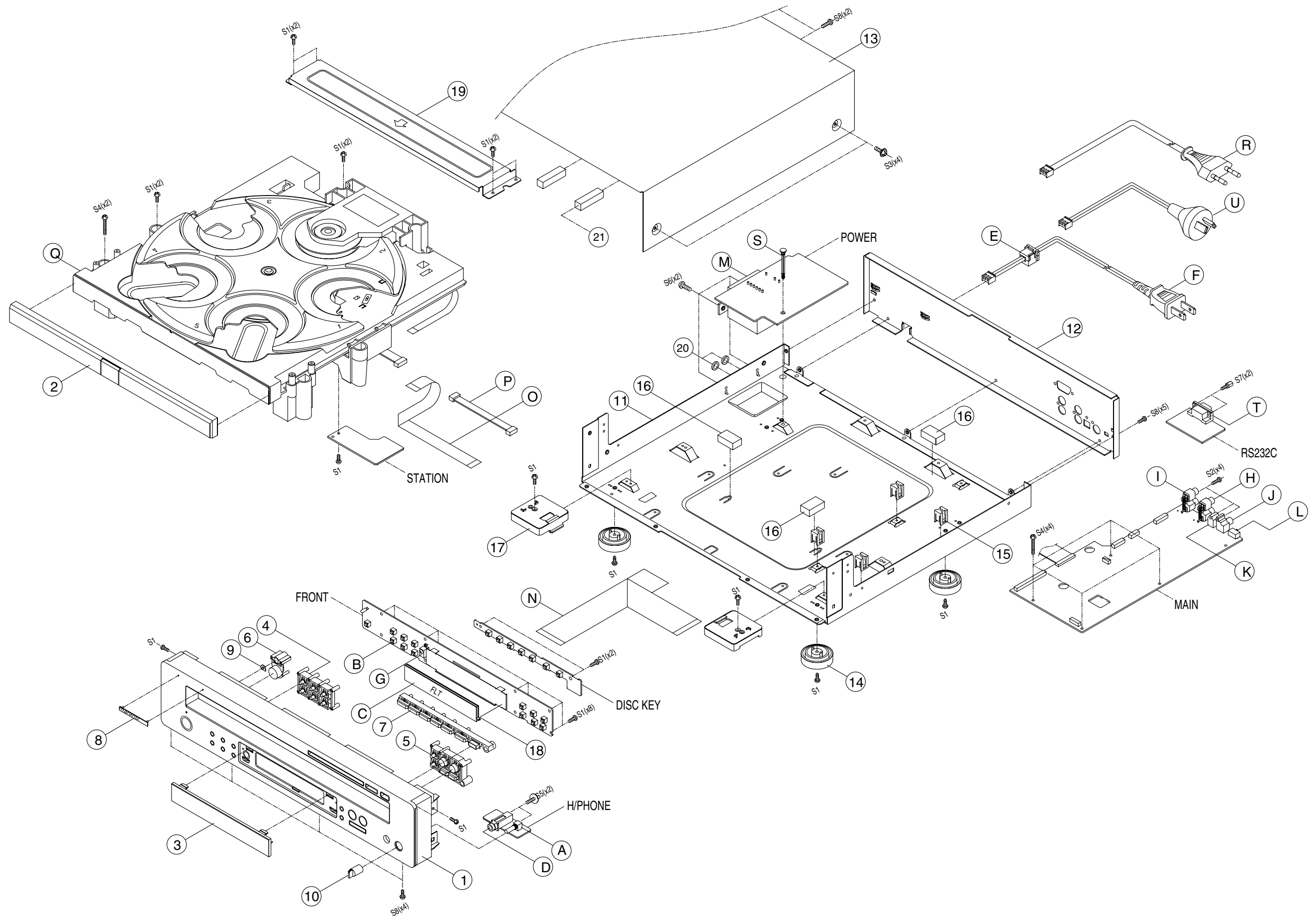

POS. NO	VERS. COLOR	PART NO. (FOR EUR)	PART NO. (MJI)	DESCRIPTION		
				<b>EXPLODED VIEW PART (MECHANISM)</b>		
1		08AW248010	08AW248010	PANEL	CC4300/U1B ABS(AF303)BK/FRONT	3067210781020
2		08AW063010	08AW063010	COVER	TRAY/ABS(AF303)BK	4317210351000
3		08AW158010	08AW158010	WINDOW	DISPLAY/ACRYL WINE	5070210783000
4		08AW270020	08AW270020	BUTTON	6KEY-A/ABS(HF380) BK	5090211631000
5		08AW270030	08AW270030	BUTTON	6KEY-B/ABS(HF380) BK	5097211641000
6		08AW270010	08AW270010	BUTTON	POWER/ABS(HF380) BK	5090211651000
7		08AW270040	08AW270040	BUTTON	CC4300/U1B 7KEY/ABS(HF380) BK	5097211661000
8		168W251010	168W251010	BADGE	BADGE(MARANTZ)	563704097802A
9		nsp	nsp	INDICATOR	GUIDE LED AX9030	5160041003010
10		08AW154010	08AW154010	KNOB	VOLUME/ABS(HF380)	5080210541000
11		nsp	nsp	CHASSIS MAIN		3200210206100Z
12	/A	nsp	nsp	CHASSIS REAR PANEL	BACK CHASSIS CC4300/A1B	3207042616250Z
12	/F	nsp	nsp	CHASSIS REAR PANEL	BACK CHASSIS CC4300/F1B	3207042616240Z
12	/N	nsp	nsp	CHASSIS REAR PANEL	BACK CHASSIS CC4300/N1B	3207042616230Z
12	/U	nsp	nsp	CHASSIS REAR PANEL	BACK CHASSIS CC4300/U1B	3207042616220Z
13		nsp	nsp	CABINET (TOP COVER)	BLACK	3000044516000Z
14		322W057010	322W057010	FOOT	FOOT (GOLD AM4736-615AL) HOT STAMPING	4007040241030
15		nsp	nsp	SUPPORTER	HCD60M ABS/PCB	4070000980000
16		nsp	nsp	CUSHION	D-XW33(J) EVA 30x15x12t /PCB	4050210415000
17		nsp	nsp	GUIDE	CC4300/U1B MECHA/ABS(AF380)BK	4350210021000
18		nsp	nsp	BRACKET	CDC5090R(DOM) ET.HD0.3t(A4)/VFD	4010210296000
19		nsp	nsp	BRACKET	CC4300/U1B FRAME/FRONT	4010211256000
20		nsp	nsp	CUSHION	AVC1500(N) RUBBER BK(PI18xPI10x3.5T)/RUBBER	4050210165000
21		nsp	nsp	CUSHION	CC4300/U1B TOP COVER/CR60	4050210665000
A		*RB000020R	*RB000020R	VR ROTARY 9MM	RK0971220-2KBx2-M(ALPS)	C451122200100
B		*SP001140R	*SP001140R	SW TACT	SKHV10920A 5MM/260G-REEL	G180000270010
C		*HQ300560R	*HQ300560R	DISPLAY FLT	HNA-09SM13 49PIN(ANGLE)	K530001270030
D		nsp	nsp	JACK D6.5	HTJ064-11D(G)/WTJ06411D(G)WELLCO	G402040161330
E	/F	nsp	323W259020	STOPPER	CORD HOLDER DACH-2	4380040172010
E	/U/N/A	323W259030	323W259030	STOPPER	CORD HOLDER DACH-1	4380040162010
⚠	F	/U	nsp	*YC000690R	MAINS CORD ASSY SPT2 10A/125V	L06802003008C
⚠	F	/F	nsp	*YC000700R	MAINS CORD ASSY KP235 12A/125V	L068000000080
G		*HW100580R	*HW100580R	MODULE REMOCON	NJL64H360A 36kHz	E940643600000
H		*YJ002490R	*YJ002490R	TER RCA 2PIN	JK020130LN(GND PLATE&PIN)/ORINGE	G601020130050
I		*YT002800R	*YT002800R	TER RCA 2PIN	JK020130PN(GND PLATE&PIN)	G601020130020
J		*YT002670R	*YT002670R	TER RCA 1PIN	JE010003PN(GND) BLACK	G600010003050
K		*YT002580R	*YT002580R	MODULE	GP1FA502TZ /OPTICAL TRANSMIT 96kHz	E100150200030
L		*SS000700R	*SS000700R	SW SLIDE	SSAF112NA011	G060112011010
⚠	M	/F	nsp	*TS001670R	POWER TRANS CC4300(F1B) 100V/50Hz 48x25	8200480250090
⚠	M	/N/A	nsp	*TS001660R	POWER TRANS CC4300(N1B) 230V/50Hz 48x25	8200480250100
⚠	M	/U	nsp	*TS001650R	POWER TRANS CC4300(U1B) 120V/60Hz 48x25	8200480250080
N		*YU001020R	*YU001020R	CABLE FLAT CARD	1.25x35*320xD(5/5/10)x(0.1x0.8)	L301321350010
O		*YU001010R	*YU001010R	CABLE FLAT CARD	1.0x16x250xC(5/5/10)x(0.035x0.65)	L301251160010
P		nsp	nsp	CN WIRE	120MM/6P GIL-S-06=PHR-06 WH20080#28	L000121060020
Q		nsp	nsp	MECHA ASSY	ICM04B MECHA ASSY (LOADER AND TRAVERSE)	8038041479010Z
⚠	R	/N	nsp	*YC000680R	MAINS CORD ASSY(N) HITACHI EHD477A	L06804001102C
S		nsp	nsp	FASTENER	BUTTON SUPPORT DABS-35R	4420210023010
T		nsp	nsp	CN.WAFER INTERFACE	9P FEMAIL D-SUB (SH232CF)	L103090090020
⚠	U	/A	nsp	*YC000670R	MAINS CORD ASSY 7.5A/250V 2M	L06804023001C
S1		nsp	nsp	SCREW TAP TITE	+2S 3x8 B-TYPE ZNY/BH	B020030081B10
S2		nsp	nsp	SCREW TAP TITE	AVR3300(E3)(DENON) +2S 3x10 B-TYPE(DOT) BK/BH	B020030103B11
S3		nsp	nsp	SCREW TAP TITE	+3S 4x8 BK/BH	B020940083B10
S4		nsp	nsp	SCREW TAP TITE	+2S 3x17 B-TYPE ZNY/BH	B020030171B10

NOTE : \*nsp\* PART IS LISTED FOR REFERENCE ONLY, MARANTZ WILL NOT SUPPLY THESE PARTS.

POS. NO	VERS. COLOR	PART NO. (FOR EUR)	PART NO. (MJI)	DESCRIPTION		
S5		nsp	nsp	SCREW	+2S 3x8 ZnY WASHER P112	1500001456010
S6		nsp	nsp	SCREW TAP TITE	+3S 4x8 S-TYPE ZNY/BH	B020740081B10
S7		nsp	nsp	SUPPORT	STUD NO4-4OUNC H=5.0	4120100177010
S8		nsp	nsp	SCREW TAP TITE	+2S 3x8 B-TYPE BK/BH	B020030083B10
M01		nsp	nsp	BODY	MECHA	3410041401010
M02		08AW163010	08AW163010	TRAY	LOADING	4600040241010
M03		08AW163020	08AW163020	ROULETTE	TRAY	2720040061010
M04		08AW401020	08AW401020	BASE	PU DRIVE	3400041391010
M05		08AW058020	08AW058020	GEAR	CENTER (A)	2470040291010
M06		08AW058010	08AW058010	GEAR	CENTER (B)	2470040211010
M07		08AW058030	08AW058030	GEAR	TRAY	2470040683010
M08		08AW262010	08AW262010	GEAR	PULLEY	2470040341010
M09		08AW360010	08AW360010	SLIDER	FUNCTION	2640040031010
M10		08AW354010	08AW354010	ARM	GEAR	2540041133010
M11		08AW262020	08AW262020	PULLEY	MOTOR	2500000310000
M12		08AW116010	08AW116010	PLATE	PRESSURE	4470043826010
M13		08AW264010	08AW264010	BELT	LOADING	2490040595010
M14		08AW058050	08AW058050	GEAR	W-WHEEL	2530041563010
M15		08AW058040	08AW058040	GEAR	WORM	2470040693010
M16		08AW358010	08AW358010	ROLLER	TRAY	2520040473010
M17		nsp	nsp	POLY WASHER	8x14x0.5t	1537040366010
M18		nsp	nsp	SPRING	ROULETTE	3720044506010
M19		nsp	nsp	PLATE CLAMPER		4470004050000
M20		nsp	nsp	MAGNET		7800GZ3400L10
M21		08AW005010	08AW005010	CLAMP	BASE	4330020041010
M22		nsp	nsp	CON'T L=70	MOTOR	L000079550000
M23		nsp	nsp	CON'T L=350	LOADING	L000079520000
M24		*YU001040R	*YU001040R	FLAT CABLE	25P(P=1L=230MM)	L301700360010
M25		08AW056010	08AW056010	INSULATOR RED		1240020135020
M26		08AW056020	08AW056020	INSULATOR GREEN		1240020135010
M27		08AW051010	08AW051010	GUIDE	TRAY	4350042061010
M28		nsp	nsp	PCB OF SENSOR		7020059830000
M29		nsp	nsp	HOUSING 6P		4428606965000
A		08AW304500	08AW304500	TRAVERSE(PICK UP UNIT KSN213CCM)		8030040622010
B		*SM000400R	*SM000400R	SW LEVER	SSCF21062A	G140040220010
C		*MM001240R	*MM001240R	MOTOR	DC FF-130SH-14230	G700040400010
D		*MM001250R	*MM001250R	MOTOR	DC SM3220BT	G700322000110
E		*HW100610R	*HW100610R	PHOTO SENSOR	SG-23F1	K611230000000
F		*HW100620R	*HW100620R	PHOTO SENSOR	ON2173-RS	K611217300000
				<b>PACKING</b>		
	/F	nsp	08AW851110	USER GUIDE (/F)		5707047250070
	/N/A	08AW851310	08AW851310	USER GUIDE (/N/A)		5707047250060
	/U	nsp	08AW851250	USER GUIDE (/U)		5707047250050
		nsp	ZK08AW0010	REMOTE CONTROLLER RC4300CC		8300430000010
				<b>NOT STANDARD SPEAR PARTS</b>		
		08AW801010	08AW801010	PACKING CASE		6017040940150
		08AW809010	08AW809010	CUSHION SNOW L/R		6230210444000
		nsp	nsp	BATTERY DRY		G670001R50010
	/F	nsp	nsp	POST CARD(JAPAN)		5777200120030
	/F	nsp	nsp	CARD WARRANTY(JAPAN)		5777200120040
	/N	nsp	nsp	CARD IMPORTANT		5777200120050
	/U	nsp	nsp	CARD WARRANTY(USA)		5777200120010
	/U	nsp	nsp	CARD WARRANTY(CANADA)		5777200120020

NOTE : "nsp" PART IS LISTED FOR REFERENCE ONLY, MARANTZ WILL NOT SUPPLY THESE PARTS.



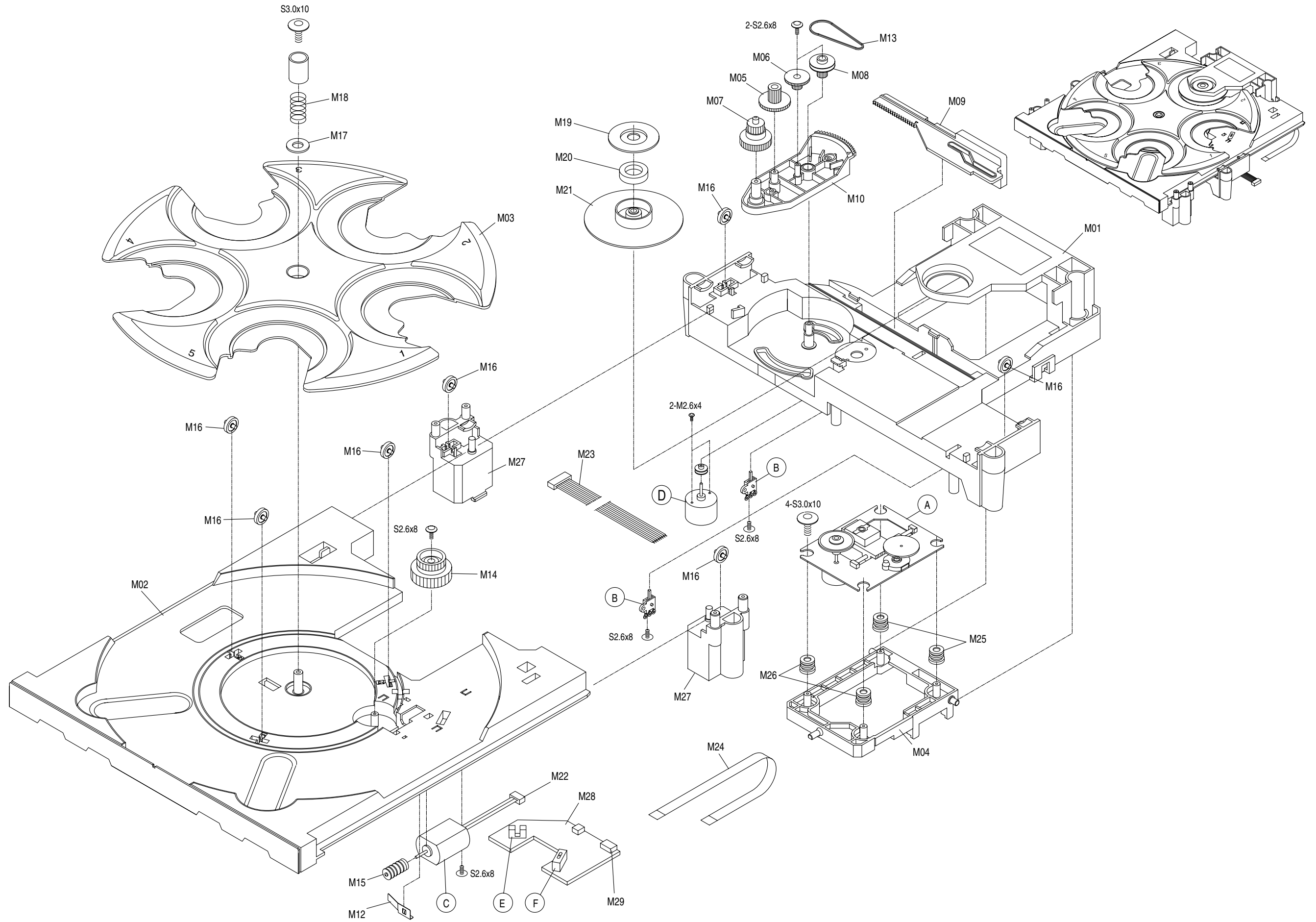

# 11. ELECTRICAL PARTS LIST

## ASSIGNMENT OF COMMON PARTS CODES.

### RESISTORS

R\*\*\*: 1) GD05xxx140, Carbon film fixed resistor, ±5% 1/4W  
 R\*\*\*: 2) GD05xxx160, Carbon film fixed resistor, ±5% 1/6W

① Resistance value

Examples ;

① Resistance value  
 0.1 Ω ... 001 10 Ω ... 100 1 kΩ ... 102 100 kΩ ... 104  
 0.5 Ω ... 005 18 Ω ... 180 2.7 kΩ ... 272 680 kΩ ... 684  
 1 Ω ... 010 100 Ω ... 101 10 kΩ ... 103 1 MΩ ... 105  
 6.8 Ω ... 068 390 Ω ... 391 22 kΩ ... 223 4.7 MΩ ... 475

Note : Please distinguish 1/4W from 1/6W by the shape of parts used actually.

### CAPACITORS

C\*\*\*: CERAMIC CAP.

3) DD1xxx370, Ceramic capacitor  
 Disc type  
 Temp.coef.P350 ~N1000, 50V  
 ② Capacity value  
 ③ Tolerance

Examples ;

② Tolerance (Capacity deviation)  
 ±0.25 pF ... 0  
 ±0.5 pF ... 1  
 ±5% ... 5

\* Tolerance of COMMON PARTS handled here are as follows :

0.5 pF ~ 5 pF ... ±0.25 pF  
 6 pF ~ 10 pF ... ±0.5 pF  
 12 pF ~ 560 pF ... ±5%

③ Capacity value

0.5 pF ... 005 3 pF ... 030 100 pF ... 101  
 1 pF ... 010 10 pF ... 100 220 pF ... 221  
 1.5 pF ... 015 47 pF ... 470 560 pF ... 561

C\*\*\* : CERAMIC CAP.

4) DK16xxx300, High dielectric constant ceramic capacitor  
 Disc type  
 Temp.chara. 2B4, 50V  
 ④ Capacity value

Examples ;

④ Capacity value  
 100 pF ... 101 1000 pF ... 102 10000 pF ... 103  
 470 pF ... 471 2200 pF ... 222

C\*\*\* : 5) ELECTROLY CAP. (  $\text{Z}$  ), 6) FILM CAP. (  $\text{Z}$  )

5) EAxxx10, Electrolytic capacitor  
 One-way lead type, Tolerance ±20%  
 ⑤ Working voltage  
 ⑥ Capacity value

Examples ;

⑤ Capacity value  
 0.1 μF ... 104 4.7 μF ... 475 100 μF ... 107  
 0.33 μF ... 334 10 μF ... 106 330 μF ... 337  
 1 μF ... 105 22 μF ... 226 1100 μF ... 118  
 2200 μF ... 228

⑥ Working voltage

6.3V ... 006 25V ... 025  
 10V ... 010 35V ... 035  
 16V ... 016 50V ... 050

6) DF15xxx350 Plastic film capacitor  
 One-way type, Mylar ±5% 50V  
 DF15xxx310 Plastic film capacitor  
 One-way type, Mylar ±10% 50V  
 ⑦ Capacity value

Examples ;

⑦ Capacity value  
 0.001 μF (1000 pF) ... 102 0.1 μF ... 104  
 0.0018 μF ... 182 0.56 μF ... 564  
 0.01 μF ... 103 1 μF ... 105  
 0.015 μF ... 153

NOTE : 1) The above CODES ( R\*\*\*, R\*\*\*, C\*\*\*, C\*\*\* and C\*\*\* ) are omitted on the schematic diagram in some case.

2) On the occasion, be confirmed the common parts on the parts list.

3) Refer to "Common Parts List" for the other common parts (RI05, DD4, DK4).

## NOTE ON SAFETY FOR FUSIBLE RESISTOR :

The suppliers and their type numbers of fusible resistors are as follows;

1. KOA Corporation

Part No. (MJI) Type No. (KOA) Description  
 NH05xxx140 → RF25SxxxxΩJ (±5% 1/4W)  
 NH05xxx120 → RF50SxxxxΩJ (±5% 1/2W)  
 NH85xxx110 → RF73B2AxxxxΩJ (±5% 1/10W)  
 NH95xxx140 → RF73B2ExxxxΩJ (±5% 1/4W)

\* Resistance value Resistance value (0.1 Ω – 10 kΩ)

2. Matsushita Electronic Components Co., Ltd

Part No. (MJI) Type No. (MEC) Description  
 NF05xxx140 → ERD-2FCJxxx (±5% 1/4W)  
 RF05xxx140 → ERD-2FCGxxx (±2% 1/4W)  
 NF02xxx140 → ERD-2FCGxxx (±2% 1/4W)  
 RF02xxx140 → ERD-2FCGxxx (±2% 1/4W)

\* Resistance value \* Resistance value

Examples ;

\* Resistance value  
 0.1 Ω ... 001 10 Ω ... 100 1 kΩ ... 102 100 kΩ ... 104  
 0.5 Ω ... 005 18 Ω ... 180 2.7 kΩ ... 272 680 kΩ ... 684  
 1 Ω ... 010 100 Ω ... 101 10 kΩ ... 103 1 MΩ ... 105  
 6.8 Ω ... 068 390 Ω ... 391 22 kΩ ... 223 4.7 MΩ ... 475

## ABBREVIATION AND MARKS

ANT. : ANTENNA	BATT. : BATTERY
CAP. : CAPACITOR	CER. : CERAMIC
CONN. : CONNECTING	DIG. : DIGITAL
HP : HEADPHONE	MIC. : MICROPHONE
μ-PRO : MICROPROCESSOR	REC. : RECORDING
RES. : RESISTOR	SPK : SPEAKER
SW : SWITCH	TRANSF. : TRANSFORMER
TRIM. : TRIMMING	TRS. : TRANSISTOR
VAR. : VARIABLE	X'TAL : CRYSTAL

## NOTE ON FUSE :

Regarding to all parts of parts code **FS20xxx2xx**, replace only with Wickmann-Werke GmbH, Type 372 non glass type fuse.

## NOTE ON SAFETY :

Symbol Fire or electrical shock hazard. Only original parts should be used to replaced any part marked with symbol . Any other component substitution (other than original type), may increase risk of fire or electrical shock hazard.

## 安全上の注意 :

がついている部品は、安全上重要な部品です。必ず指定されている部品番号の部品を使用して下さい。

POS. NO	VERS. COLOR	PART NO. (FOR EUR)	PART NO. (MJI)	DESCRIPTION
				<b>MAIN P.C.B</b>
BEAD101		nsp	nsp	BEAD COIL BAS3580T0 3.5PHI*8 52RE 7610035800020
BEAD102		nsp	nsp	BEAD COIL BAS3580T0 3.5PHI*8 52RE 7610035800020
BEAD103		nsp	nsp	BEAD COIL BAS3580T0 3.5PHI*8 52RE 7610035800020
BEAD104		nsp	nsp	BEAD COIL BAS3580T0 3.5PHI*8 52RE 7610035800020
BEAD106		nsp	nsp	BEAD COIL BAS3580T0 3.5PHI*8 52RE 7610035800020
C101		nsp	nsp	C CERAMIC HIK AXIAL F0.1UF-Z/50V-52RE D005104597530
C102		nsp	nsp	C ELECT GE 85C 220UF-M/10V 6.3*11-5RE.SMS-SY D040221082050
C103		nsp	nsp	C CERAMIC HIK AXIAL Y0.01UF-M/16V-52RE D005103773530
C104		nsp	nsp	C ELECT GE 85C 22UF-M/50V 5*11-5RE.SY D040220087060
C105		nsp	nsp	C CERAMIC HIK AXIAL Y0.01UF-M/16V-52RE D005103773530
C106		nsp	nsp	C ELECT GE 85C 100UF-M/50J 8*11.5 D040101087100
C107		*EA001100R	*EA001100R	C DOUBLE LAYER(70) 0.047F 5.5V VEND ESR45OHM D090473704010
C108		nsp	nsp	C ELECT GE 85C 1UF-M/50V 5*11-5RE D040010087050
C109		nsp	nsp	C ELECT GE 85C 100UF-M/10V 5*11-5RE D040101082060
C110		nsp	nsp	C CERAMIC HIK AXIAL Y0.01UF-M/16V-52RE D005103773530
C111		nsp	nsp	C ELECT GE 85C 100UF-M/10V 5*11-5RE D040101082060
C112		nsp	nsp	C CERAMIC HIK AXIAL F0.1UF-Z/50V-52RE D005104597530
C113		nsp	nsp	C ELECT GE 85C 100UF-M/10V 5*11-5RE D040101082060
C114		nsp	nsp	C ELECT GE 85C 100UF-M/10V 5*11-5RE D040101082060
C115		nsp	nsp	C CERAMIC HIK AXIAL F0.1UF-Z/50V-52RE D005104597530
C116		nsp	nsp	C CERAMIC HIK AXIAL F0.1UF-Z/50V-52RE D005104597530
C117		nsp	nsp	C CERAMIC HIK AXIAL F0.1UF-Z/50V-52RE D005104597530
C118		nsp	nsp	C CERAMIC HIK AXIAL X0.0033UF-M/16-52RE D005332773530
C119		nsp	nsp	C ELECT GE 85C 0.47UF-M/50V 5*11-5RE SY D040R47087050
C120		nsp	nsp	C ELECT GE 85C 100UF-M/10V 5*11-5RE D040101082060
C121		nsp	nsp	C CERAMIC HIK AXIAL Y0.01UF-M/16V-52RE D005103773530
C122		nsp	nsp	C CERAMIC HIK AXIAL B560PF-K/50V-52RE D005561277520
C123		nsp	nsp	C CERAMIC HIK AXIAL F0.1UF-Z/50V-52RE D005104597530
C124		nsp	nsp	C ELECT GE 85C 10UF-M/16V 5*11 D040100083100
C125		nsp	nsp	C CERAMIC HIK AXIAL F0.047UF-Z/50V-52RE D005473597520
C126		nsp	nsp	C CERAMIC HIK AXIAL X0.0015UF-M/16V-52RE D005152773530
C127		nsp	nsp	C CERAMIC T.C AXIAL SL15PF-J/50V-52RE D001150067520
C128		nsp	nsp	C CERAMIC T.C AXIAL SL15PF-J/50V-52RE D001150067520
C129		nsp	nsp	C CERAMIC HIK AXIAL B100PF-K/50V-52RE D005101177520
C130		nsp	nsp	C CERAMIC HIK AXIAL F0.1UF-Z/50V-52RE D005104597530
C131		nsp	nsp	C CERAMIC HIK AXIAL Y0.01UF-M/16V-52RE D005103773530
C132		nsp	nsp	C CERAMIC HIK AXIAL F0.1UF-Z/50V-52RE D005104597530
C133		nsp	nsp	C ELECT GE 85C 100UF-M/10V 5*11-5RE D040101082060
C135		nsp	nsp	C ELECT GE 85C 470UF-M/10V 6.3*11-5RE D040471082060
C136		nsp	nsp	C ELECT GE 85C 2.2UF-M/50V 5*11-5RE D0402R2087100
C137		nsp	nsp	C ELECT GE 85C 100UF-M/10V 5*11-5RE D040101082060
C138		nsp	nsp	C ELECT GE 85C 1UF-M/50V 5*11-5RE D040010087050
C139		nsp	nsp	C CERAMIC HIK AXIAL B0.001UF-K/50V-52RE D005102177530
C140		nsp	nsp	C ELECT GE 85C 100UF-M/10V 5*11-5RE D040101082060
C141		nsp	nsp	C CERAMIC HIK AXIAL Y0.01UF-M/16V-52RE D005103773530
C142		nsp	nsp	C CERAMIC T.C AXIAL SL47PF-J/50V-52RE D001470067520
C143		nsp	nsp	C CERAMIC HIK AXIAL F0.1UF-Z/50V-52RE D005104597530
C144		nsp	nsp	C CERAMIC HIK AXIAL F0.1UF-Z/50V-52RE D005104597530
C145		nsp	nsp	C CERAMIC HIK AXIAL B470PF-K/50V-52RE D005471277520
C146		nsp	nsp	C CERAMIC HIK AXIAL B470PF-K/50V-52RE D005471277520
C147		nsp	nsp	C CERAMIC HIK AXIAL F0.1UF-Z/50V-52RE D005104597530
C148		nsp	nsp	C ELECT GE 85C 100UF-M/10V 5*11-5RE D040101082060
C149		nsp	nsp	C CERAMIC HIK AXIAL B0.001UF-K/50V-52RE D005102177530
C150		nsp	nsp	C CERAMIC HIK AXIAL B0.001UF-K/50V-52RE D005102177530
C151		nsp	nsp	C ELECT AH 85C 10UF-M/35V 6.3*11 D046100085100
C152		nsp	nsp	C ELECT GE 85C 22UF-M/50V 5*11-5RE.SY D040220087060

POS. NO	VERS. COLOR	PART NO. (FOR EUR)	PART NO. (MJI)	DESCRIPTION		
C153		nsp	nsp	C ELECT GE 85C	22UF-M/50V 5*11-5RE.SY	D040220087060
C154		nsp	nsp	C CERAMIC HIK AXIAL	B470PF-K/50V-52RE	D005471277520
C155		nsp	nsp	C ELECT GE 85C	100UF-M/10V 5*11-5RE	D040101082060
C156		nsp	nsp	C CERAMIC T.C AXIAL	SL47PF-J/50V-52Re	D001470067520
C157		nsp	nsp	C ELECT AH 85C	10UF-M/35V 6.3*11	D046100085100
C158		nsp	nsp	C CERAMIC HIK AXIAL	F0.1UF-Z/50V-52RE	D005104597530
C159		nsp	nsp	C ELECT AH 85C	10UF-M/35V 6.3*11	D046100085100
C160		nsp	nsp	C ELECT AH 85C	10UF-M/35V 6.3*11	D046100085100
C161		nsp	nsp	C CERAMIC HIK AXIAL	Y0.01UF-M/16V-52RE	D005103773530
C162		nsp	nsp	C ELECT GE 85C	22UF-M/50V 5*11-5RE.SY	D040220087060
C163		nsp	nsp	C CERAMIC T.C AXIAL	SL56PF-J/50V-52RE	D001560067520
C164		nsp	nsp	C ELECT AH 85C	47UF-M/16V 8*11.5	D046470083100
C165		nsp	nsp	C ELECT GE 85C	10UF-M/16V 5*11	D040100083100
C166		nsp	nsp	C ELECT GE 85C	10UF-M/16V 5*11	D040100083100
C167		nsp	nsp	C ELECT GE 85C	220UF-M/10V 6.3*11-5RE.SMS-SY	D040221082050
C168		nsp	nsp	C CERAMIC T.C AXIAL	SL3.3PF-K/50V-52RE	D0013R3077520
C169		nsp	nsp	C CERAMIC HIK AXIAL	F0.1UF-Z/50V-52RE	D005104597530
C170		nsp	nsp	C ELECT AH 85C	47UF-M/16V 8*11.5	D046470083100
C171		nsp	nsp	C CERAMIC HIK AXIAL	B0.001UF-K/50V-52RE	D005102177530
C172		nsp	nsp	C CERAMIC HIK AXIAL	F0.1UF-Z/50V-52RE	D005104597530
C173		nsp	nsp	C CERAMIC T.C AXIAL	SL27PF-J/50V-52RE	D001270067520
C174		nsp	nsp	C CERAMIC HIK AXIAL	B0.001UF-K/50V-52RE	D005102177530
C175		nsp	nsp	C CERAMIC HIK AXIAL	B150PF-K/50V-52RE	D005151177530
C176		nsp	nsp	C ELECT GE 85C	22UF-M/50V 5*11-5RE.SY	D040220087060
C177		nsp	nsp	C ELECT GE 85C	100UF-M/10V 5*11-5RE	D040101082060
C178		nsp	nsp	C CERAMIC HIK AXIAL	F0.1UF-Z/50V-52RE	D005104597530
C179		nsp	nsp	C CERAMIC HIK AXIAL	Y0.01UF-M/16V-52RE	D005103773530
C180		nsp	nsp	C CERAMIC HIK AXIAL	F0.022UF-Z/25V-52RE	D005223594520
C181		nsp	nsp	C CERAMIC HIK AXIAL	F0.1UF-Z/50V-52RE	D005104597530
C182		nsp	nsp	C CERAMIC T.C AXIAL	SL56PF-J/50V-52RE	D001560067520
C183		nsp	nsp	C CERAMIC HIK AXIAL	B470PF-K/50V-52RE	D005471277520
C184		nsp	nsp	C ELECT GE 85C	1UF-M/50V 5*11-5RE	D040010087050
C185		nsp	nsp	C CERAMIC HIK AXIAL	F0.1UF-Z/50V-52RE	D005104597530
C190		nsp	nsp	C ELECT GE 85C	2200UF-M/10V 12.5*20	D040222082100
CLAMP101		nsp	nsp	CLAMP	HMX9800 DARA-2(W=2.6 L=50)/WIRE(SOLDER)	4330000120000
CN102		nsp	nsp	CN WIRE	320/13P 5264-13=5395-13 RD1007#26	L000321130010
CN107		nsp	nsp	CN WIRE	100MM/3P 9073-03=51004-03 RD1007#26	L000101030100
CP101		nsp	nsp	CN.FPC 1.25MM	6126 35P ST 1.25 1S	L131621603500
CP103		nsp	nsp	CN.WAFER 2.0MM	53014-0810 8P	L101530140810
CP104		nsp	nsp	CN.WAFER 2.0MM	G1L-S-6P-S2T2-EF	L101220060000
CP105		nsp	nsp	CN.FPC 1.25MM	8370-061 6P DIP ST	L131837000600
CP106		nsp	nsp	CN.FPC 1.0MM	52806-1610 16P STRAIGHT	L130528061610
CP107		nsp	nsp	CN.WAFER 2.0MM	53014-0510 5P	L101530140510
D101		nsp	*HD201570R	D SWITCHING	IN4007 52REEL 1000V 1A	K000400700520
D102		nsp	*HD301670R	D ZENER	MTZJ30B-0.5W/5MA-52MM	K06030R044520
D103		nsp	HD30561000	D ZENER	MTZJ5.6B-0.5W/5MA-52MM	K06005R644520
D104		nsp	*HD400190R	D SWITCHING	1N4148-52RE 75V 150MA DO-34 (MIC)	K000414803520
D105		nsp	*HD400190R	D SWITCHING	1N4148-52RE 75V 150MA DO-34 (MIC)	K000414803520
D106		nsp	HD30431000	D ZENER	MTZJ4.3B-0.5W/5MA-52MM	K06004R344520
D107		nsp	*HD400190R	D SWITCHING	1N4148-52RE 75V 150MA DO-34 (MIC)	K000414803520
D108		nsp	*HD400190R	D SWITCHING	1N4148-52RE 75V 150MA DO-34 (MIC)	K000414803520
D109		nsp	*HD400190R	D SWITCHING	1N4148-52RE 75V 150MA DO-34 (MIC)	K000414803520
D110		nsp	*HD302070R	D ZENER	MTZJ2.2B-0.5W/5MA-52MM	K06002R244520
D111		nsp	*HD400190R	D SWITCHING	1N4148-52RE 75V 150MA DO-34 (MIC)	K000414803520
D112		nsp	*HD400190R	D SWITCHING	1N4148-52RE 75V 150MA DO-34 (MIC)	K000414803520
D113		nsp	*HD302080R	D ZENER	MTZJ3.3B-0.5W/5MA-52MM	K06003R344520
GND101		nsp	nsp	TERMINAL	ALL PBST/GND PLATE-REEL	3790040876010

NOTE : \*nsp\* PART IS LISTED FOR REFERENCE ONLY, MARANTZ WILL NOT SUPPLY THESE PARTS.

POS. NO	VERS. COLOR	PART NO. (FOR EUR)	PART NO. (MJI)	DESCRIPTION		
GND102		nsp	nsp	TERMINAL	ALL PBST/GND PLATE-REEL	3790040876010
IC101		*HU100590R	*HU100590R	IC CPU MICRO PROCESS	CXP82532-306Q/QFP80 CC4300 DWP367	J020825323060
IC102		*HC108040R	*HC108040R	IC OPTICAL-DSP	CXD3017Q QFP80 /P236V	J031301700020
IC103		*HC108070R	*HC108070R	IC ANALOG	CXA2571N-T4 RF MATRIX AMP /CDP	J080257100010
IC104		*HC000060R	*HC000060R	IC LOGIC	TC74HCT7007AF/MFP14P	J040747007010
IC105		*HC107400R	*HC107400R	IC LINEAR-DRIVER	BA5979S/DIP32P	J127597900020
IC106		*HC108080R	*HC108080R	IC LINEAR OP	NJM2114D-DIP8P	J121211400010
IC107		*HC108050R	*HC108050R	IC LOGIC-D/A CONVER	IC SM5882AS SOP 8P	J042588200010
IC108		*HC107410R	*HC107410R	IC LINEAR-DRIVER	BA6956AN SIP9 /MOTOR DRIVER	J127695600010
IC109		*HC107410R	*HC107410R	IC LINEAR-DRIVER	BA6956AN SIP9 /MOTOR DRIVER	J127695600010
IC110		*HC107380R	*HC107380R	IC LINEAR OP	NJM2068MD-SOP8P	J121206800030
J101		nsp	nsp	CN WIRE 1P	JUMPER (0.6/52MM)	L045084006040
J102		nsp	nsp	CN WIRE 1P	JUMPER (0.6/52MM)	L045084006040
J103		nsp	nsp	CN WIRE 1P	JUMPER (0.6/52MM)	L045084006040
J104		nsp	nsp	CN WIRE 1P	JUMPER (0.6/52MM)	L045084006040
J105		nsp	nsp	CN WIRE 1P	JUMPER (0.6/52MM)	L045084006040
J106		nsp	nsp	CN WIRE 1P	JUMPER (0.6/52MM)	L045084006040
J107		nsp	nsp	CN WIRE 1P	JUMPER (0.6/52MM)	L045084006040
J108		nsp	nsp	CN WIRE 1P	JUMPER (0.6/52MM)	L045084006040
J109		nsp	nsp	CN WIRE 1P	JUMPER (0.6/52MM)	L045084006040
J110		nsp	nsp	CN WIRE 1P	JUMPER (0.6/52MM)	L045084006040
J111		nsp	nsp	CN WIRE 1P	JUMPER (0.6/52MM)	L045084006040
J112		nsp	nsp	CN WIRE 1P	JUMPER (0.6/52MM)	L045084006040
J113		nsp	nsp	CN WIRE 1P	JUMPER (0.6/52MM)	L045084006040
J114		nsp	nsp	CN WIRE 1P	JUMPER (0.6/52MM)	L045084006040
J115		nsp	nsp	CN WIRE 1P	JUMPER (0.6/52MM)	L045084006040
J116		nsp	nsp	CN WIRE 1P	JUMPER (0.6/52MM)	L045084006040
J117		nsp	nsp	CN WIRE 1P	JUMPER (0.6/52MM)	L045084006040
J118		nsp	nsp	CN WIRE 1P	JUMPER (0.6/52MM)	L045084006040
J119		nsp	nsp	CN WIRE 1P	JUMPER (0.6/52MM)	L045084006040
J120		nsp	nsp	CN WIRE 1P	JUMPER (0.6/52MM)	L045084006040
J121		nsp	nsp	CN WIRE 1P	JUMPER (0.6/52MM)	L045084006040
J122		nsp	nsp	CN WIRE 1P	JUMPER (0.6/52MM)	L045084006040
J123		nsp	nsp	CN WIRE 1P	JUMPER (0.6/52MM)	L045084006040
J124		nsp	nsp	CN WIRE 1P	JUMPER (0.6/52MM)	L045084006040
J125		nsp	nsp	CN WIRE 1P	JUMPER (0.6/52MM)	L045084006040
J126		nsp	nsp	CN WIRE 1P	JUMPER (0.6/52MM)	L045084006040
J127		nsp	nsp	CN WIRE 1P	JUMPER (0.6/52MM)	L045084006040
J128		nsp	nsp	CN WIRE 1P	JUMPER (0.6/52MM)	L045084006040
J129		nsp	nsp	CN WIRE 1P	JUMPER (0.6/52MM)	L045084006040
J130		nsp	nsp	CN WIRE 1P	JUMPER (0.6/52MM)	L045084006040
J131		nsp	nsp	CN WIRE 1P	JUMPER (0.6/52MM)	L045084006040
J132		nsp	nsp	CN WIRE 1P	JUMPER (0.6/52MM)	L045084006040
J133		nsp	nsp	CN WIRE 1P	JUMPER (0.6/52MM)	L045084006040
J134		nsp	nsp	CN WIRE 1P	JUMPER (0.6/52MM)	L045084006040
J135		nsp	nsp	CN WIRE 1P	JUMPER (0.6/52MM)	L045084006040
J136		nsp	nsp	CN WIRE 1P	JUMPER (0.6/52MM)	L045084006040
J137		nsp	nsp	CN WIRE 1P	JUMPER (0.6/52MM)	L045084006040
J139		nsp	nsp	CN WIRE 1P	JUMPER (0.6/52MM)	L045084006040
J140		nsp	nsp	CN WIRE 1P	JUMPER (0.6/52MM)	L045084006040
J141		nsp	nsp	CN WIRE 1P	JUMPER (0.6/52MM)	L045084006040
J142		nsp	nsp	CN WIRE 1P	JUMPER (0.6/52MM)	L045084006040
J143		nsp	nsp	CN WIRE 1P	JUMPER (0.6/52MM)	L045084006040
J144		nsp	nsp	CN WIRE 1P	JUMPER (0.6/52MM)	L045084006040
J145		nsp	nsp	CN WIRE 1P	JUMPER (0.6/52MM)	L045084006040
J146		nsp	nsp	CN WIRE 1P	JUMPER (0.6/52MM)	L045084006040

NOTE : "nsp" PART IS LISTED FOR REFERENCE ONLY, MARANTZ WILL NOT SUPPLY THESE PARTS.

POS. NO	VERS. COLOR	PART NO. (FOR EUR)	PART NO. (MJI)	DESCRIPTION		
J147		nsp	nsp	CN WIRE 1P	JUMPER (0.6/52MM)	L045084006040
J148		nsp	nsp	CN WIRE 1P	JUMPER (0.6/52MM)	L045084006040
J149		nsp	nsp	CN WIRE 1P	JUMPER (0.6/52MM)	L045084006040
J150		nsp	nsp	CN WIRE 1P	JUMPER (0.6/52MM)	L045084006040
J151		nsp	nsp	CN WIRE 1P	JUMPER (0.6/52MM)	L045084006040
J152		nsp	nsp	CN WIRE 1P	JUMPER (0.6/52MM)	L045084006040
JACK101		*YJ002490R	*YJ002490R	TER CINCH 2PIN	JK020130LN(GND PLATE&PIN)/ORANGE	G601020130050
JACK102		*YT002800R	*YT002800R	TER CINCH 2PIN	JK020130PN(GND PLATE&PIN)	G601020130020
JACK103		*YT002670R	*YT002670R	TER CINCH 1PIN	JE010003PN(GND) BLACK	G600010003050
L102		nsp	nsp	COIL FILTER-INDUCTOR	10UH-Q40/24M-R2.5-52RE 02TB	D330100700520
L103		nsp	nsp	COIL FILTER-INDUCTOR	10UH-Q40/24M-R2.5-52RE 02TB	D330100700520
LUG101		nsp	nsp	RING TER WIRE	60MM/1P 61640BS-2(3.2) SIN-21T-1.8S BK1007#18	8410600180010
PLT101		*YT002580R	*YT002580R	MODULE	GP1FA502TZ /OPTICAL TRANSMIT 96kHz SHUTTER	E100150200030
Q101		*BA001250R	*BA001250R	SEMI TR/GE PNP 2SA	KTA1273Y 1W/TO92L-REEL	J5001273Y0050
Q102		*BA001260R	*BA001260R	SEMI TR/GE NPN 2SC	KTC3205Y 1W/TO92L-REEL	J5023205Y0020
Q103		*HT800010R	*HT800010R	SEMI TR/GE NPN 2SC	TR NPN 2SC3199Y (BKTC3199 Y	J5023199Y0050
Q104		*BA001210R	*BA001210R	SEMI BRT/PNP RA	KRA102M 0.3W/TO92M-REEL	J6002202M0010
Q105		*BA001200R	*BA001200R	SEMI BRT/PNP RA	KRA111M 0.4W/TO92M-REEL	J6000111M0010
Q106		*BA001180R	*BA001180R	SEMI BRT/NPN RC	KRC102M 0.4W/TO92M-REEL	J6020102M0010
Q107		*BA001210R	*BA001210R	SEMI BRT/PNP RA	KRA102M 0.3W/TO92M-REEL	J6002202M0010
Q108		*BA001210R	*BA001210R	SEMI BRT/PNP RA	KRA102M 0.3W/TO92M-REEL	J6002202M0010
Q109		*BA001390R	*BA001390R	SEMI BRT/NPN RC	DTC144ES 0.3W/TO92M-REEL	J6020144E0010
Q110		*BA001240R	*BA001240R	SEMI TR/GE PNP 2SA	KTA1270Y 0.5W/TO92-REEL	J5001270Y0050
Q111		*BA001210R	*BA001210R	SEMI BRT/PNP RA	KRA102M 0.3W/TO92M-REEL	J6002202M0010
Q112		*HT300880R	*HT300880R	SEMI TR/GE NPN 2SC	KTC2874B TO92-REEL	J502287400010
Q113		*BA001070R	*BA001070R	SEMI BRT/NPN RC	KRC107M 0.4W/TO92M-REEL	J6020107M0010
Q114		*HT300880R	*HT300880R	SEMI TR/GE NPN 2SC	KTC2874B TO92-REEL	J502287400010
Q115		*BA001070R	*BA001070R	SEMI BRT/NPN RC	KRC107M 0.4W/TO92M-REEL	J6020107M0010
Q116		*BA001070R	*BA001070R	SEMI BRT/NPN RC	KRC107M 0.4W/TO92M-REEL	J6020107M0010
Q117		*BA001410R	*BA001410R	SEMI BRT/NPN RC	KRC111M 0.3W/TO92M-REEL	J6020111M0010
Q118		*BA001410R	*BA001410R	SEMI BRT/NPN RC	KRC111M 0.3W/TO92M-REEL	J6020111M0010
Q119		*BA001180R	*BA001180R	SEMI BRT/NPN RC	KRC102M 0.4W/TO92M-REEL	J6020102M0010
R100		nsp	nsp	R CARBON FILM	4.7K-J 1/5W-52RE-AX	C00004726P520
R101		nsp	nsp	R CARBON FILM	330-J 1/5W-52RE-AX	C00003316P520
R102		nsp	nsp	R CARBON FILM	10K-J 1/5W-52RE-AX	C00001036P520
R103		nsp	nsp	R CARBON FILM	100-J 1/5W-52RE	C00001016P520
R104		nsp	nsp	R CARBON FILM	100-J 1/5W-52RE	C00001016P520
R105		nsp	nsp	R CARBON FILM	47K-J 1/5W-52RE-AX	C00004736P520
R106		nsp	nsp	R CARBON FILM	1-J 1/5W-52RE-AX	C00000106P520
R107		nsp	nsp	R CARBON FILM	1.8K-J 1/5W-52RE-AX	C00001826P520
R108		nsp	nsp	R CARBON FILM	10K-J 1/5W-52RE-AX	C00001036P520
R109		nsp	nsp	R CARBON FILM	3.3K-J 1/5W-52RE-AX	C00003326P520
R110		nsp	nsp	R CARBON FILM	1K-J 1/5W-52RE-AX	C00001026P520
R111		nsp	nsp	R CARBON FILM	1K-J 1/5W-52RE-AX	C00001026P520
R112		nsp	nsp	R CARBON FILM	1K-J 1/5W-52RE-AX	C00001026P520
R113		nsp	nsp	R CARBON FILM	10K-J 1/5W-52RE-AX	C00001036P520
R114		nsp	nsp	R CARBON FILM	1K-J 1/5W-52RE-AX	C00001026P520
R115		nsp	nsp	R CARBON FILM	1K-J 1/5W-52RE-AX	C00001026P520
R116		nsp	nsp	R CARBON FILM	1K-J 1/5W-52RE-AX	C00001026P520
R117		nsp	nsp	R CARBON FILM	1K-J 1/5W-52RE-AX	C00001026P520
R118		nsp	nsp	R CARBON FILM	10K-J 1/5W-52RE-AX	C00001036P520
R119		nsp	nsp	R CARBON FILM	75-J 1/5W-52RE-AX	C00007506P520
R120		nsp	nsp	R CARBON FILM	3.6K-J 1/5W-52RE-AX	C00003626P520
R121		nsp	nsp	R CARBON FILM	4.7K-J 1/5W-52RE-AX	C00004726P520

NOTE : \*nsp\* PART IS LISTED FOR REFERENCE ONLY, MARANTZ WILL NOT SUPPLY THESE PARTS.

POS. NO	VERS. COLOR	PART NO. (FOR EUR)	PART NO. (MJI)	DESCRIPTION	
R122		nsp	nsp	R CARBON FILM 2.2-J 1/4W-52RE-AX	C0002R2063520
R123		nsp	nsp	R CARBON FILM 5.6K-J 1/5W-52RE-AX	C00005626P520
R124		nsp	nsp	R CARBON FILM 1.8K-J 1/5W-52RE-AX	C00001826P520
R125		nsp	nsp	R CARBON FILM 2.2-J 1/4W-52RE-AX	C0002R2063520
R126		nsp	nsp	R CARBON FILM 10K-J 1/5W-52RE-AX	C00001036P520
R127		nsp	nsp	R CARBON FILM 10K-J 1/5W-52RE-AX	C00001036P520
R128		nsp	nsp	R CARBON FILM 10K-J 1/5W-52RE-AX	C00001036P520
R129		nsp	nsp	R CARBON FILM 10K-J 1/5W-52RE-AX	C00001036P520
R130		nsp	nsp	R CARBON FILM 100K-J 1/5W-52RE-AX	C00001046P520
R131		nsp	nsp	R CARBON FILM 100K-J 1/5W-52RE-AX	C00001046P520
R132		nsp	nsp	R CARBON FILM 1M-J 1/5W-52RE-AX	C00001056P520
R133		nsp	nsp	R CARBON FILM 33K-J 1/5W-52RE-AX	C00003336P520
R134		nsp	nsp	R CARBON FILM 1M-J 1/5W-52RE-AX	C00001056P520
R135		nsp	nsp	R CARBON FILM 3.3K-J 1/5W-52RE-AX	C00003326P520
R136		nsp	nsp	R CARBON FILM 3.3K-J 1/5W-52RE-AX	C00003326P520
R137		nsp	nsp	R CARBON FILM 10K-J 1/5W-52RE-AX	C00001036P520
R138		nsp	nsp	R CARBON FILM 10K-J 1/5W-52RE-AX	C00001036P520
R139		nsp	nsp	R CARBON FILM 47-J 1/5W-52RE-AX	C00004706P520
R140		nsp	nsp	R CARBON FILM 220K-J 1/5W-52RE-AX	C00002246P520
R141		nsp	nsp	R CARBON FILM 470K-J 1/5W-52RE-AX	C00004746P520
R142		nsp	nsp	R CARBON FILM 100-J 1/5W-52RE	C00001016P520
R143		nsp	nsp	R CARBON FILM 100-J 1/5W-52RE	C00001016P520
R145		nsp	nsp	R CARBON FILM 18K-J 1/5W-52RE-AX	C00001836P520
R146		nsp	nsp	R CARBON FILM 47-J 1/5W-52RE-AX	C00004706P520
R147		nsp	nsp	R CARBON FILM 33K-J 1/5W-52RE-AX	C00003336P520
R148		nsp	nsp	R CARBON FILM 18K-J 1/5W-52RE-AX	C00001836P520
R149		nsp	nsp	R CARBON FILM 33K-J 1/5W-52RE-AX	C00003336P520
R150		nsp	nsp	R CARBON FILM 470K-J 1/5W-52RE-AX	C00004746P520
R151		nsp	nsp	R CARBON FILM 10K-J 1/5W-52RE-AX	C00001036P520
R152		nsp	nsp	R CARBON FILM 100-J 1/5W-52RE	C00001016P520
R153		nsp	nsp	R CARBON FILM 10-J 1/5W-52RE-AX	C00001006P520
R154		nsp	nsp	R CARBON FILM 47-J 1/5W-52RE-AX	C00004706P520
R155		nsp	nsp	R CARBON FILM 15K-J 1/5W-52RE-AX	C00001536P520
R156		nsp	nsp	R CARBON FILM 180K-J 1/5W-52RE-AX	C00001846P520
R157		nsp	nsp	R CARBON FILM 150K-J 1/5W-52RE-AX	C00001546P520
R158		nsp	nsp	R CARBON FILM 1.2K-J 1/5W-52RE-AX	C00001226P520
R159		nsp	nsp	R CARBON FILM 470-J 1/5W-52RE-AX	C00004716P520
R160		nsp	nsp	R CARBON FILM 10K-J 1/5W-52RE-AX	C00001036P520
R161		nsp	nsp	R CARBON FILM 33K-J 1/5W-52RE-AX	C00003336P520
R162		nsp	nsp	R CARBON FILM 47-J 1/5W-52RE-AX	C00004706P520
R163		nsp	nsp	R CARBON FILM 10K-J 1/5W-52RE-AX	C00001036P520
R164		nsp	nsp	R CARBON FILM 33K-J 1/5W-52RE-AX	C00003336P520
R165		nsp	nsp	R CARBON FILM 100-J 1/5W-52RE	C00001016P520
R166		nsp	nsp	R CARBON FILM 47-J 1/5W-52RE-AX	C00004706P520
R167		nsp	nsp	R CARBON FILM 2.2-J 1/5W-52RE-AX	C0002R206P520
R168		nsp	nsp	R CARBON FILM 47-J 1/5W-52RE-AX	C00004706P520
R170		nsp	nsp	R CARBON FILM 100K-J 1/5W-52RE-AX	C00001046P520
R171		nsp	nsp	R CARBON FILM 1K-J 1/5W-52RE-AX	C00001026P520
R172		nsp	nsp	R CARBON FILM 10K-J 1/5W-52RE-AX	C00001036P520
R173		nsp	nsp	R CARBON FILM 3.3K-J 1/5W-52RE-AX	C00003326P520
R176		nsp	nsp	R CARBON FILM 39K-J 1/5W-52RE-AX	C00003936P520
R177		nsp	nsp	R CARBON FILM 33K-J 1/5W-52RE-AX	C00003336P520
R178		nsp	nsp	R CARBON FILM 33K-J 1/5W-52RE-AX	C00003336P520
R179		nsp	nsp	R CARBON FILM 1K-J 1/5W-52RE-AX	C00001026P520
R180		nsp	nsp	R CARBON FILM 220K-J 1/5W-52RE-AX	C00002246P520
R181		nsp	nsp	R CARBON FILM 100K-J 1/5W-52RE-AX	C00001046P520
R182		nsp	nsp	R CARBON FILM 3.3K-J 1/5W-52RE-AX	C00003326P520

NOTE : "nsp" PART IS LISTED FOR REFERENCE ONLY, MARANTZ WILL NOT SUPPLY THESE PARTS.

POS. NO	VERS. COLOR	PART NO. (FOR EUR)	PART NO. (MJI)	DESCRIPTION		
R183		nsp	nsp	R CARBON FILM	39K-J 1/5W-52RE-AX	C00003936P520
R185		nsp	nsp	R CARBON FILM	100-J 1/5W-52RE	C00001016P520
R187		nsp	nsp	R CARBON FILM	100K-J 1/5W-52RE-AX	C00001046P520
R188		nsp	nsp	R CARBON FILM	8.2K-J 1/5W-52RE-AX	C00008226P520
R189		nsp	nsp	R CARBON FILM	8.2K-J 1/5W-52RE-AX	C00008226P520
R190		nsp	nsp	R CARBON FILM	2.2K-J 1/5W-52RE-AX	C00002226P520
R191		nsp	nsp	R CARBON FILM	270-J 1/5W-52RE-AX	C00002716P520
R192		nsp	nsp	R CARBON FILM	10-J 1/5W-52RE-AX	C00001006P520
R193		nsp	nsp	R CARBON FILM	100K-J 1/5W-52RE-AX	C00001046P520
R194		nsp	nsp	R CARBON FILM	2.2K-J 1/5W-52RE-AX	C00002226P520
R195		nsp	nsp	R CARBON FILM	10K-J 1/5W-52RE-AX	C00001036P520
R196		nsp	nsp	R CARBON FILM	4.7K-J 1/5W-52RE-AX	C00004726P520
R197		nsp	nsp	R CARBON FILM	1K-J 1/5W-52RE-AX	C00001026P520
R198		nsp	nsp	R CARBON FILM	1K-J 1/5W-52RE-AX	C00001026P520
R199		nsp	nsp	R CARBON FILM	4.7K-J 1/5W-52RE-AX	C00004726P520
R601		nsp	nsp	R CARBON FILM	1K-J 1/5W-52RE-AX	C00001026P520
R602		nsp	nsp	R CARBON FILM	1K-J 1/5W-52RE-AX	C00001026P520
R603		nsp	nsp	R CARBON FILM	1K-J 1/5W-52RE-AX	C00001026P520
R604		nsp	nsp	R CARBON FILM	1K-J 1/5W-52RE-AX	C00001026P520
R605		nsp	nsp	R CARBON FILM	1K-J 1/5W-52RE-AX	C00001026P520
R607		nsp	nsp	R CARBON FILM	1K-J 1/5W-52RE-AX	C00001026P520
R610		nsp	nsp	R CARBON FILM	100K-J 1/5W-52RE-AX	C00001046P520
R611		nsp	nsp	R CARBON FILM	10K-J 1/5W-52RE-AX	C00001036P520
R613		nsp	nsp	R CARBON FILM	15K-J 1/5W-52RE-AX	C00001536P520
R614		nsp	nsp	R CARBON FILM	3.9K-J 1/5W-52RE-AX	C00003926P520
R615		nsp	nsp	R CARBON FILM	47-J 1/5W-52RE-AX	C00004706P520
R617		nsp	nsp	R CARBON FILM	1K-J 1/5W-52RE-AX	C00001026P520
R618		nsp	nsp	R CARBON FILM	3.3K-J 1/5W-52RE-AX	C00003326P520
R619		nsp	nsp	R CARBON FILM	1K-J 1/5W-52RE-AX	C00001026P520
R620		nsp	nsp	R CARBON FILM	1K-J 1/5W-52RE-AX	C00001026P520
R621		nsp	nsp	R CARBON FILM	47-J 1/5W-52RE-AX	C00004706P520
R622		nsp	nsp	R CARBON FILM	2.2K-J 1/5W-52RE-AX	C00002226P520
R623		nsp	nsp	R CARBON FILM	1K-J 1/5W-52RE-AX	C00001026P520
R624		nsp	nsp	R CARBON FILM	3.3K-J 1/5W-52RE-AX	C00003326P520
R625		nsp	nsp	R CARBON FILM	1K-J 1/5W-52RE-AX	C00001026P520
R626		nsp	nsp	R CARBON FILM	10K-J 1/5W-52RE-AX	C00001036P520
SW101		*SS000700R	*SS000700R	SW SLIDE	SSAF112NA011	G060112011010
XTAL101		*FQ000350R	*FQ000350R	RESONATOR CERAMIC	CST10.0MTW-TF01/REEL CSTLA10M0T55-A0	E830100000050
XTAL102		*JX000960R	*JX000960R	CRYSTAL	HC-49S 16.9344MHz CL=12PF 5REEL(CRIMPED)	E800169344510
				<b>FRONT P.C.B.</b>		
C201		nsp	nsp	C CERAMIC HIK AXIAL	B100PF-K/50V-52RE	D005101177520
C202		nsp	nsp	C CERAMIC HIK AXIAL	B100PF-K/50V-52RE	D005101177520
C203		nsp	nsp	C CERAMIC HIK AXIAL	B100PF-K/50V-52RE	D005101177520
C204		nsp	nsp	C CERAMIC HIK AXIAL	B100PF-K/50V-52RE	D005101177520
C205		nsp	nsp	C ELECT GE 85C	100UF-M/10V 5*11-5RE	D040101082060
CN201		nsp	nsp	CN WIRE	120/6P 9073-06=9073-06 RD#26	L000121060050
CP201		nsp	nsp	CN.FPC 1.25MM	52492-3520 35P BOTTOM ENTRY	L131524923520
D201		nsp	*HD400190R	D SWITCHING	1N4148-52RE 75V 150MA DO-34 (MIC)	K000414803520
D202		nsp	*HD400190R	D SWITCHING	1N4148-52RE 75V 150MA DO-34 (MIC)	K000414803520
D203		nsp	*HD400190R	D SWITCHING	1N4148-52RE 75V 150MA DO-34 (MIC)	K000414803520
D204		nsp	*HD400190R	D SWITCHING	1N4148-52RE 75V 150MA DO-34 (MIC)	K000414803520
D205		nsp	*HD400190R	D SWITCHING	1N4148-52RE 75V 150MA DO-34 (MIC)	K000414803520
D206		nsp	*HD400190R	D SWITCHING	1N4148-52RE 75V 150MA DO-34 (MIC)	K000414803520
FLT201		*HQ300560R	*HQ300560R	DISPLAY FLT	HNA-09SM13 49PIN(ANGLE)	K530001270030
GUIDE201		nsp	nsp	BRACKET	CDC5090R(DOM) ET.HD0.3t(A4)/VFD	4010210296000

NOTE : "nsp" PART IS LISTED FOR REFERENCE ONLY, MARANTZ WILL NOT SUPPLY THESE PARTS.

POS. NO	VERS. COLOR	PART NO. (FOR EUR)	PART NO. (MJI)	DESCRIPTION		
J201		nsp	nsp	CN WIRE 1P	JUMPER (0.6/52MM)	L045084006040
J202		nsp	nsp	CN WIRE 1P	JUMPER (0.6/52MM)	L045084006040
J203		nsp	nsp	CN WIRE 1P	JUMPER (0.6/52MM)	L045084006040
J204		nsp	nsp	CN WIRE 1P	JUMPER (0.6/52MM)	L045084006040
J205		nsp	nsp	CN WIRE 1P	JUMPER (0.6/52MM)	L045084006040
J206		nsp	nsp	CN WIRE 1P	JUMPER (0.6/52MM)	L045084006040
J207		nsp	nsp	CN WIRE 1P	JUMPER (0.6/52MM)	L045084006040
J208		nsp	nsp	CN WIRE 1P	JUMPER (0.6/52MM)	L045084006040
J209		nsp	nsp	CN WIRE 1P	JUMPER (0.6/52MM)	L045084006040
J210		nsp	nsp	CN WIRE 1P	JUMPER (0.6/52MM)	L045084006040
J211		nsp	nsp	CN WIRE 1P	JUMPER (0.6/52MM)	L045084006040
J212		nsp	nsp	CN WIRE 1P	JUMPER (0.6/52MM)	L045084006040
J213		nsp	nsp	CN WIRE 1P	JUMPER (0.6/52MM)	L045084006040
J214		nsp	nsp	CN WIRE 1P	JUMPER (0.6/52MM)	L045084006040
J215		nsp	nsp	CN WIRE 1P	JUMPER (0.6/52MM)	L045084006040
LED201		*HI100710R	*HI100710R	LED ROUND	LED SLR-34URCF25	K500032101120
Q201		*BA001070R	*BA001070R	SEMI BRT/NPN RC	KRC107M 0.4W/TO92M-REEL	J6020107M0010
R201		nsp	nsp	R CARBON FILM	10K-J 1/5W-52RE-AX	C00001036P520
R202		nsp	nsp	R CARBON FILM	10K-J 1/5W-52RE-AX	C00001036P520
R203		nsp	nsp	R CARBON FILM	10K-J 1/5W-52RE-AX	C00001036P520
R204		nsp	nsp	R CARBON FILM	10K-J 1/5W-52RE-AX	C00001036P520
R209		nsp	nsp	R CARBON FILM	330-J 1/5W-52RE-AX	C00003316P520
R216		nsp	nsp	R CARBON FILM	47-J 1/5W-52RE-AX	C00004706P520
SEN201		*HW100580R	*HW100580R	MODULE REMOCON	NJL64H360A 36kHz	E940643600000
SW201		nsp	*SP001140R	SW TACT	SKHV10920A 5MM/260G-REEL	G180000270010
SW202		nsp	*SP001140R	SW TACT	SKHV10920A 5MM/260G-REEL	G180000270010
SW203		nsp	*SP001140R	SW TACT	SKHV10920A 5MM/260G-REEL	G180000270010
SW204		nsp	*SP001140R	SW TACT	SKHV10920A 5MM/260G-REEL	G180000270010
SW205		nsp	*SP001140R	SW TACT	SKHV10920A 5MM/260G-REEL	G180000270010
SW206		nsp	*SP001140R	SW TACT	SKHV10920A 5MM/260G-REEL	G180000270010
SW207		nsp	*SP001140R	SW TACT	SKHV10920A 5MM/260G-REEL	G180000270010
SW208		nsp	*SP001140R	SW TACT	SKHV10920A 5MM/260G-REEL	G180000270010
SW209		nsp	*SP001140R	SW TACT	SKHV10920A 5MM/260G-REEL	G180000270010
SW210		nsp	*SP001140R	SW TACT	SKHV10920A 5MM/260G-REEL	G180000270010
SW212		nsp	*SP001140R	SW TACT	SKHV10920A 5MM/260G-REEL	G180000270010
SW213		nsp	*SP001140R	SW TACT	SKHV10920A 5MM/260G-REEL	G180000270010
SW214		nsp	*SP001140R	SW TACT	SKHV10920A 5MM/260G-REEL	G180000270010
				<b>POWER P.C.B</b>		
		nsp	nsp	HEAT SINK	HEAT SINK (24X30)	2120044288010
 C301		nsp	nsp	C CERAMIC AC(SAFETY)	DE2F3KH108MN4A(DE1310-469E472M) P10 25REEL	D00847208K060
C302		nsp	nsp	C ELECT GE 85C	4700UF-M/25V 16*31.5	D040472084210
C303		nsp	nsp	C ELECT GE 85C	470UF-M/25V 10*12.5-5RE.SY	D040471084060
C304		nsp	nsp	C FILM POLYESTER	ST-0.01UF-J/100V-5RE	D02010306C060
C305		nsp	nsp	C FILM POLYESTER	ST-0.01UF-J/100V-5RE	D02010306C060
C306		nsp	nsp	C CERAMIC SEMI DISC	F0.1UF-Z/50V-5RE PI6	D006104597050
C307		nsp	nsp	C FILM POLYESTER	ST-0.01UF-J/100V-5RE	D02010306C060
C308		nsp	nsp	C ELECT GE 85C	1000UF-M/35V 12.5*25L.BLK SY	D040102085030
C309		nsp	nsp	C CERAMIC SEMI DISC	F0.1UF-Z/50V-5RE PI6	D006104597050
C310		nsp	nsp	C ELECT GE 85C	100UF-M/10V 5*11-5RE	D040101082060
C311		nsp	nsp	C ELECT GE 85C	100UF-M/10V 5*11-5RE	D040101082060
C312		nsp	nsp	C CERAMIC HIK AXIAL	Y0.01UF-M/16V-52RE	D005103773530
C313		nsp	nsp	C ELECT GE 85C	22UF-M/50V 5*11-5RE.SY	D040220087060
C314		nsp	nsp	C ELECT GE 85C	22UF-M/50V 5*11-5RE.SY	D040220087060
C315		nsp	nsp	C CERAMIC SEMI DISC	F0.1UF-Z/50V-5RE PI6	D006104597050
C316		nsp	nsp	C FILM POLYESTER	ST-0.01UF-J/100V-5RE	D02010306C060

NOTE : "nsp" PART IS LISTED FOR REFERENCE ONLY, MARANTZ WILL NOT SUPPLY THESE PARTS.



POS. NO	VERS. COLOR	PART NO. (FOR EUR)	PART NO. (MJI)	DESCRIPTION		
C317		nsp	nsp	C FILM POLYESTER	ST-0.01UF-J/100V-5RE	D02010306C060
C318		nsp	nsp	C FILM POLYESTER	ST-0.01UF-J/100V-5RE	D02010306C060
C319		nsp	nsp	C ELECT GE 85C	100UF-M/10V 5*11-5RE	D040101082060
C320		nsp	nsp	C CERAMIC HIK AXIAL	F0.047UF-Z/50V-52RE	D005473597520
C321		nsp	nsp	C CERAMIC HIK AXIAL	F0.047UF-Z/50V-52RE	D005473597520
C322		nsp	nsp	C CERAMIC HIK AXIAL	Y0.01UF-M/16V-52RE	D005103773530
C323		nsp	nsp	C CERAMIC HIK AXIAL	F0.1UF-Z/50V-52RE	D005104597530
▲ C324		nsp	nsp	C CERAMIC AC(SAFETY)	DE2F3KH108MN4A(DE1310-469E472M) P10 25REEL	D00847208K060
CLIP301		nsp	nsp	HOLDER FUSE CLIP	PI5.2-REEL	G645000050010
CLIP302		nsp	nsp	HOLDER FUSE CLIP	PI5.2-REEL	G645000050010
CP301		nsp	nsp	CN.WAFER 7.92MM	YW396V(03AV)	L108039602010
CP302		nsp	nsp	CN.WAFER 2.5MM	5268-13A 13P ANGLE	L102526813010
D301		nsp	*HD201570R	D SWITCHING	IN4007 52REEL 1000V 1A	K000400700520
D302		nsp	*HD201570R	D SWITCHING	IN4007 52REEL 1000V 1A	K000400700520
D303		nsp	*HD201570R	D SWITCHING	IN4007 52REEL 1000V 1A	K000400700520
D304		nsp	*HD201570R	D SWITCHING	IN4007 52REEL 1000V 1A	K000400700520
D305		nsp	*HD400190R	D SWITCHING	1N4148-52RE 75V 150MA DO-34 (MIC)	K000414803520
D307		nsp	*HD302090R	D ZENER	MTZJ24B-0.5W/5MA-52MM	K06024R044520
D308		nsp	*HD400190R	D SWITCHING	1N4148-52RE 75V 150MA DO-34 (MIC)	K000414803520
D309		nsp	HD30431000	D ZENER	MTZJ4.3B-0.5W/5MA-52MM	K06004R344520
D310		nsp	*HD400190R	D SWITCHING	1N4148-52RE 75V 150MA DO-34 (MIC)	K000414803520
D311		nsp	*HD201570R	D SWITCHING	IN4007 52REEL 1000V 1A	K000400700520
D312		nsp	*HD201570R	D SWITCHING	IN4007 52REEL 1000V 1A	K000400700520
D313		nsp	*HD201570R	D SWITCHING	IN4007 52REEL 1000V 1A	K000400700520
D314		nsp	*HD201570R	D SWITCHING	IN4007 52REEL 1000V 1A	K000400700520
D315		nsp	*HD301970R	D ZENER	MTZJ9.1B-0.5W/5MA-52MM	K06009R144520
D316		nsp	*HD301970R	D ZENER	MTZJ9.1B-0.5W/5MA-52MM	K06009R144520
▲ F301	/N/A	*FS000790R	*FS000790R	FUSE (5.2*20)	250V-T160MA-S/V/B/R(YARN)	G650161251160
▲ F301	/U/F	nsp	*FS000930R	FUSE (5.2*20)	LF239.400 250V-400MA-SB	G650401251050
IC301		*HC300460R	*HC300460R	IC LINEAR-REGULATOR	KIA7808AP (KEC)	J126780800130
IC302		*HC300450R	*HC300450R	IC LINEAR-REGULATOR	KIA7805AP 20W TO220AB	J126780500360
IC303		HC3890509F	HC3890509F	IC LINEAR-REGULATOR	KIA7805API 20W-TO220IS MOLD	J126780500110
J302		nsp	nsp	CN WIRE 1P	JUMPER (0.6/52MM)	L045084006040
J303		nsp	nsp	CN WIRE 1P	JUMPER (0.6/52MM)	L045084006040
J304		nsp	nsp	CN WIRE 1P	JUMPER (0.6/52MM)	L045084006040
J305		nsp	nsp	CN WIRE 1P	JUMPER (0.6/52MM)	L045084006040
J306		nsp	nsp	CN WIRE 1P	JUMPER (0.6/52MM)	L045084006040
J307		nsp	nsp	CN WIRE 1P	JUMPER (0.6/52MM)	L045084006040
J308		nsp	nsp	CN WIRE 1P	JUMPER (0.6/52MM)	L045084006040
J309		nsp	nsp	CN WIRE 1P	JUMPER (0.6/52MM)	L045084006040
J310		nsp	nsp	CN WIRE 1P	JUMPER (0.6/52MM)	L045084006040
J311		nsp	nsp	CN WIRE 1P	JUMPER (0.6/52MM)	L045084006040
J312		nsp	nsp	CN WIRE 1P	JUMPER (0.6/52MM)	L045084006040
J313		nsp	nsp	CN WIRE 1P	JUMPER (0.6/52MM)	L045084006040
LUG301		nsp	nsp	CN WIRE	80MM 1P 6045BS-2XB1813TOP-2E BK1015#20	L000800010010
Q301		*BA001070R	*BA001070R	SEMI BRT/NPN RC	KRC107M 0.4W/TO92M-REEL	J6020107M0010
Q302		*BA001070R	*BA001070R	SEMI BRT/NPN RC	KRC107M 0.4W/TO92M-REEL	J6020107M0010
Q303		*BA001260R	*BA001260R	SEMI TR/GE NPN 2SC	KTC3205Y 1W/TO92L-REEL	J5023205Y0020
Q304		*BA001250R	*BA001250R	SEMI TR/GE PNP 2SA	KTA1273Y 1W/TO92L-REEL	J5001273Y0050
R301		nsp	nsp	R CARBON FILM	33-J 1/5W-52RE-AX	C00003306P520
R302		nsp	nsp	R CARBON FILM	1K-J 1/5W-52RE-AX	C00001026P520
R303		nsp	nsp	R CARBON FILM	4.7K-J 1/5W-52RE-AX	C00004726P520
R304		nsp	nsp	R CARBON FILM	4.7K-J 1/5W-52RE-AX	C00004726P520
R306		nsp	nsp	R CARBON FILM	330-J 1/5W-52RE-AX	C00003316P520
R307		nsp	nsp	R CARBON FILM	680-J 1/5W-52RE-AX	C00006816P520
RELAY301		*LY000260R	*LY000260R	RELAY	G5PA-1-8 12V 5A	G680120502010

NOTE : \*nsp\* PART IS LISTED FOR REFERENCE ONLY, MARANTZ WILL NOT SUPPLY THESE PARTS.

POS. NO	VERS. COLOR	PART NO. (FOR EUR)	PART NO. (MJI)	DESCRIPTION		
⚠	TRANS301	/U	nsp	*TS001650R	POWER TRANS	CC4300(U1B) 120V/60Hz 48*25 8200480250080
⚠	TRANS301	/N/A	*TS001660R	*TS001660R	POWER TRANS	CC4300(N1B) 230V/50Hz 48*25 8200480250100
⚠	TRANS301	/F	nsp	*TS001670R	POWER TRANS	CC4300(F1B) 100V/50Hz 48*25 8200480250090
⚠	TRANS302	/U	nsp	*TS001530R	POWER TRANS	SR6200/7200 STAND-BY 120V/60Hz 28*15 8200280150060
⚠	TRANS302	/N/A	*TS001540R	*TS001540R	TRANS ST/BY	230/50 RV5080R 28*25 I <sub>o</sub> =22MA 12.5V*0.1A(DC) 820128000011
⚠	TRANS302	/F	nsp	*TS001370R	POWER TRANS	AVC5/STAND-BY 100V 50Hz 28*15 8200280150020
<b>KEY P.C.B</b>						
	SW401		nsp	*SP001140R	SW TACT	SKHV10920A 5MM/260G-REEL G180000270010
	SW402		nsp	*SP001140R	SW TACT	SKHV10920A 5MM/260G-REEL G180000270010
	SW403		nsp	*SP001140R	SW TACT	SKHV10920A 5MM/260G-REEL G180000270010
	SW404		nsp	*SP001140R	SW TACT	SKHV10920A 5MM/260G-REEL G180000270010
	SW405		nsp	*SP001140R	SW TACT	SKHV10920A 5MM/260G-REEL G180000270010
	SW406		nsp	*SP001140R	SW TACT	SKHV10920A 5MM/260G-REEL G180000270010
	SW407		nsp	*SP001140R	SW TACT	SKHV10920A 5MM/260G-REEL G180000270010
<b>H/P (HEAD PHONES) P.C.B.</b>						
	BEAD501		nsp	nsp	BEAD COIL	BRS3550T0 3.5PHI*5 R.REEL(5MM) 7610035500010
	BEAD502		nsp	nsp	BEAD COIL	BRS3550T0 3.5PHI*5 R.REEL(5MM) 7610035500010
	C501		nsp	nsp	C ELECT GE 85C	10UF-M/16V 4*5-5RE D040100083110
	C502		nsp	nsp	C ELECT GE 85C	10UF-M/16V 4*5-5RE D040100083110
	C503		nsp	nsp	C ELECT GE 85C	220UF-M/10V 6.3*11-5RE.SMS-SY D040221082050
	C504		nsp	nsp	C ELECT GE 85C	220UF-M/10V 6.3*11-5RE.SMS-SY D040221082050
	C505		nsp	nsp	C ELECT GE 85C	47UF-M/16V 5*11-5RE.SY D040470083080
	CN501		nsp	nsp	CN WIRE	120/5P 9073-05=51004-05 RD1007#26 L000121050040
	IC501		*HC108090R	*HC108090R	IC LINEAR POWER	NJM2769BM DMP-8P /HEADPHONE AMP J122276900010
	J501		nsp	nsp	CN WIRE 1P	JUMPER (0.6/52MM) L045084006040
	JACK502		nsp	nsp	JACK D6.5	HTJ064-11D(G)/WTJ06411D(G)WELLCO G402040161330
	LUG501		nsp	nsp	CN WIRE	140MM/1P 61640BS-2XB1813TOP-2E BK1015#20 L000141010020
	VOL501		*RB000020R	*RB000020R	VR ROTARY 9MM	RK0971220-2KB*2-M(ALPS) C451122200100
<b>RS232C P.C.B.</b>						
	BD701		nsp	nsp	BEAD COIL	BAS3580T0 3.5PHI*8 52RE 7610035800020
	BD702		nsp	nsp	BEAD COIL	BAS3580T0 3.5PHI*8 52RE 7610035800020
	C701		nsp	nsp	C ELECT GE 85C	1UF-M/50V 5*11-5RE D040010087050
	C702		nsp	nsp	C ELECT GE 85C	1UF-M/50V 5*11-5RE D040010087050
	C703		nsp	nsp	C ELECT GE 85C	1UF-M/50V 5*11-5RE D040010087050
	C704		nsp	nsp	C ELECT GE 85C	1UF-M/50V 5*11-5RE D040010087050
	C705		nsp	nsp	C ELECT GE 85C	1UF-M/50V 5*11-5RE D040010087050
	CP701		nsp	nsp	CN.WAFER 2.0MM	53015-0310 3P ANGLE L101530150310
	IC701		*HC108060R	*HC108060R	IC LOGIC-INTERFACE	ST232EBN RS232 TRANSCEIVER DIP16 .ST J046232000010
	J701		nsp	nsp	CN WIRE 1P	JUMPER (0.6/52MM) L045084006040
	J702		nsp	nsp	CN WIRE 1P	JUMPER (0.6/52MM) L045084006040
	JACK701		nsp	nsp	CN.WAFER INTERFACE	9P FEMAIL D-SUB (SH232CF) L103090090020
	R701		nsp	nsp	R CARBON FILM	10-J 1/5W-52RE-AX C00001006P520

NOTE : "nsp" PART IS LISTED FOR REFERENCE ONLY, MARANTZ WILL NOT SUPPLY THESE PARTS.