

Service Manual

74 CD10 / 00B

Compact disc player

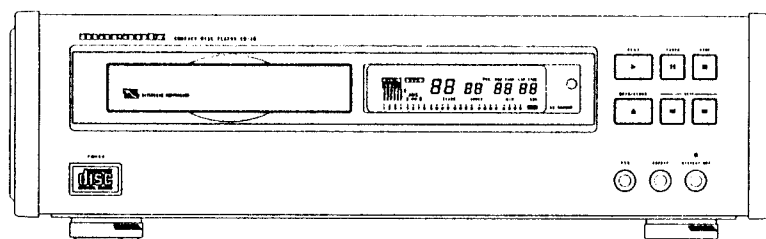

CONTENTS

SECTION	PAGE
1. TECHNICAL SPECIFICATIONS	1
2. IC PIN FUNCTIONS	3
3. BLOCK DIAGRAM	8
4. SCHEMATIC DIAGRAM AND PARTS LOCATIONS (PATTERN SIDE)	10
5. CONNECTION DIAGRAM	34
6. EXPLODED VIEW AND MECHANICAL PARTS LIST	36
7. TRAY MECHANISM LOADING PROCEDURES	40
8. PRACTICAL HINTS	42
9. INITIATING THE SERVICE PROGRAMME	43
10. MEASUREMENTS AND ADJUSTMENT FOR CDM4 (SUB CHASSIS)	45
11. DETAILED MEASURING METHOD FOR THE SERVO + PRE-AMPLIFIER CIRCUIT	46
12. DETAILED MEASURING METHOD FOR THE DECODER CIRCUIT	49
13. ELECTRICAL PARTS LIST	52

4822 725 51012

marantz®

model CD-10

First issue : 1992

PCS67 925

MARANTZ DESIGN AND SERVICE

Using superior design and selected high grade components, MARANTZ company has created the ultimate in stereo sound. Only original MARANTZ parts can insure that your MARANTZ product will continue to perform to the specifications for which it is famous.

Parts for your MARANTZ equipment are generally available at our National Marantz Subsidiary or Agent.

ORDERING PARTS

Parts can be ordered either by mail or by telex. In both cases, the correct part number has to be specified. The following information must be supplied to eliminate delays in processing your order:

1. Complete address
2. Complete part numbers and quantities required
3. Description of parts
4. Model number for which the part is required
5. Way of shipment
6. Signature: any order form or telex must be signed, otherwise such part order will be considered as null and void.

ADDRESSES

AUSTRIA MARANTZ Hietzingerg. Ka. 137a 1130 Wien Austria	FRANCE MARANTZ FRANCE 4 Rue Bernard Palissy 92600 Asnières France	ITALY MARANTZ ITALIANA SPA Piazza IV Novembre 3 20124 Milano Italy	NORWAY MARANTZ Postboks 7034 Assiden 3007 Drammen Norway	SPAIN MARANTZ SPAIN Martinez Villergas 4 Apartado 2065 Madrid 28027 Spain
BELGIUM MARANTZ EUROPE B.V. Div. Benelux P.O. Box 218 Building HCM9 5600 MD Eindhoven The Netherlands	GERMANY MARANTZ GERMANY GmbH Alexanderstrasse 1 2000 Hamburg Germany	JAPAN MARANTZ JAPAN INC. 35-1, 7-chome, Sagamiono Sagamihara-shi, Kanagawa Japan	PORTUGAL COREL Av. da Liberdade 211-2 Esq. 1200 Lisboa Portugal	SWEDEN MARANTZ Box 1324 17125 Solna Sweden
CHILE MARANTZ DIVISION OF PHILIPS S.A. Av. Santa Mana 0760 Casilla 2687 Santiago Chile	GREAT BRITAIN MARANTZ HiFi UK Ltd. Kingsbridge House Padbury Oaks 575-583 Bath Road Longford Middlesex UB7 0EH, U.K.	KUWAIT AL ALAMIAH ELECTRONICS P.O. Box 8196 Salmiah 22052 Kuwait	SAUDI ARABIA AL ALAMIAH ELECTRONICS P.O. Box 5954 University Street Riyadh 11432 Saudi Arabia	SWITZERLAND MARANTZ SWITZERLAND Postfach 8010 Zurich Switzerland
DENMARK MARANTZ Horsvinget 5 2630 Tastrup Denmark	GREECE ADAMCO ELECTR. SA P.O. Box 21025 Hippocrates Str. 188 Athens 11471 Greece	NETHERLANDS MARANTZ EUROPE B.V. Div. Benelux P.O. Box 218 Building HCM9 5600 MD Eindhoven The Netherlands	SOUTH AFRICA MARANTZ S.A. 10 Bond Street Randburg 2194 P.O. Box 7703 Johannesburg 2000 South Africa	TRADING MARANTZ TRADING P.O. Box 218 Building HCM9 5600 MD Eindhoven The Netherlands
FINLAND MARANTZ Kuortanegatan 1 00520 Helsingfors 52 Finland				

All of the above locations are fully equipped to take care of your total service needs or can advise you. Because various countries have differing configuration requirements, it is necessary that you contact the service facility in your particular country. In the event that there is no service location listed for your country, please contact the nearest facility for the necessary assistance.

In case of difficulties, do not hesitate to contact the Technical Department at above mentioned address.

1 TECHNICAL SPECIFICATIONS

Audio Characteristics

Channels 2 channels
D/A conversion 1-bit linear/channel

Frequency Characteristics

Line output jack 20 to 20,000 Hz, ± 0.2 dB
Dynamic range 96 dB
S/N ratio 108 dB
Channel separation 100 dB or more (1 kHz)
THD 0.0015 % (1 kHz)
Wow & flutter Precision of quartz
Analog output jacks Output level 2 V RMS
Line output jacks Output impedance 100 ohms
Matching load impedance 10 k ohms or more
Digital output Pin jack, 0.5 Vp-p/75 ohms
(Rectangular optical connector)
optical output -19 dBm

Optical Readout System

Laser AlGAs semiconductor
Wavelength 780 nm

Signal System

Sampling frequency 44.1 kHz
Quantization 16-bit linear/channel
Error correction Cross-interleave read solomon code (CIRC).
Class A D/A conversion

Power Supply

Voltage 230 V
Line Frequency 50 Hz or 60 Hz
Power Consumption 18 W

Cabinet, etc.

Dimensions
Width 457 mm
Height 136 mm
Depth 358 mm
Weight Approx. 16.5 kg
Operating temperature + 5°C ~ + 35°C
Operating humidity 5 % ~ 65 % (without Dew)

Accessories

Remote control unit (RC-10 CD) 1
Dimensions (W x H x D) 60 x 15 x 175 mm
Weight (without batteries) 85 g
R03 Batteries 2
Stereo audio cable with RCA pins 1 Pair
Digital signal cable with RCA pins 1

* Improvement may result in changes in specifications and design without notice.

SERVICE TOOLS

Audio signals disc	4822 397 30184
Disc without errors (test disc 5) + disc with DO errors, black spots and fingerprints (test disc 5A)	4822 397 30096
Disc 65 min 1 kHz without pause	4822 397 30155
Max. diameter disc(58.0 mm)	4822 397 60141
Torx screwdrivers	
Set (straight)	4822 395 50145
Set (square)	4822 395 50132
13th order filter	4822 395 30204
Service cable (4p)	4822 321 21284
Service flexfoil (14p)	4822 322 40066
Service connector (14p)	4822 267 50676
Green LED CQY G11	5322 130 32182
Insulation cover	4822 444 60655

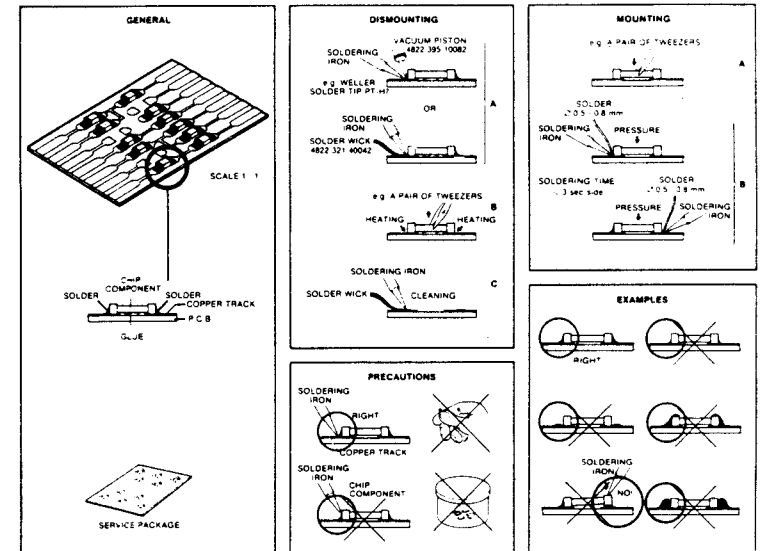

GB WARNING

All ICs and many other semi-conductors are susceptible to electrostatic discharges (ESD). Careless handling during repair can reduce life drastically.
When repairing, make sure that you are connected with the same potential as the mass of the set via a wrist wrap with resistance. Keep components and tools also at this potential.

F ATTENTION

Tous les IC et beaucoup d'autres semi-conducteurs sont sensibles aux décharges statiques (ESD). Leur longévité pourrait être considérablement écourtée par le fait qu'aucune précaution n'est prise à leur manipulation.
Lors de réparations, s'assurer de bien être relié au même potentiel que la masse de l'appareil et enfiler le bracelet sert d'une résistance de sécurité.
Veiller à ce que les composants ainsi que les outils que l'on utilise soient également à ce potentiel.

D WARNUNG

Alle ICs und viele andere Halbleiter sind empfindlich gegen elektrostatische Entladungen (ESD).
Unvorsorgliche Behandlung bei der Reparatur kann die Lebensdauer drastisch vermindern. Sorgen Sie dafür, dass Sie im Reparaturfall über ein Pulsarmband mit Widerstand mit dem Massepotential des Gerätes verbunden sind. Halten Sie Bauteile und Hilfsmittel ebenfalls auf diesem Potential.

NL WAARSCHUWING

Alle IC's en vele andere halfgeleiders zijn gevoelig voor electrostatische ontladings (ESD).
Onzorgvuldig behandelen tijdens reparatie kan de levensduur drastisch doen verminderen. Zorg ervoor dat u tijdens reparatie via een polsband met weerstand verbonden bent met hetzelfde potentiaal als de massa van het apparaat.
Houd componenten en hulpmiddelen ook op ditzelfde potentiaal.

I AVVERTIMENTO

Tutti IC e parecchi semi-conduttori sono sensibili alle scariche statiche (ESD).
La loro longevità potrebbe essere fortemente ridotta in caso di non osservazione della più grande cauzione alla loro manipolazione.
Durante le riparazioni occorre quindi essere collegato allo stesso potenziale che quello della massa dell'apparecchio tramite un bracciale a resistenza.
Assicurarsi che i componenti e anche gli utensili con quali si lavora siano anche a questo potenziale.

Q101 : TDA8808T

pin	mnemonic	description
1	GCHF	Gain control input of HF amplifier. Current output from HF amplitude detector
2	Vp	Positive supply voltage
3	HFout	HF amplifier and equalizer voltage output
4	DET	HF detector voltage input
5	Sc	Starting up capacitor input
6	Si/ \overline{RD}	On/off control (start input); ready signal output (starting up procedure successful)
7	Beq	Equalizer reference current input
8	Bgc	DC and LF gain control reference current input
9	FOC START	Focus normalizing circuit starting current
10	PLLH	PLL on hold output
11	\overline{TL}	Track loss output
12	\overline{DODS}	Drop out detector suppression input
13	V _{ext}	TDA8808T Negative supply connection for FE and FE _{lag} output stage; also substrate connection TDA8808AT Positive supply connection for FE and FE _{lag} output stage
14	LPF	Low pass filter for I _{ret} , used in track loss (\overline{TL}) detector and LF gain control
15	FE	Current output of normalized, switched focus error signal
16	FE _{lag}	Current output of switched focus error signal, intended for lag network
17	LO	Laser amplifier current output
18	LM	Laser monitor diode input
19	GCLF	Gain control input for AC and LF amplifiers. Current output from LF amplitude detector
20	Re2	Summation of amplified currents from D3 and D4
21	Re1	Summation of amplified currents from D1 and D2
23, 22	D1, D2	Current inputs to DC and LF photo diode amplifier
24, 25	D3, D4	Current inputs to DC and LF photo diode amplifier
26	HFin	Current input to HF amplifier
27	GND	Ground connection of device; also substrate connection for TDA8808AT
28	DEC	Decoupling input (internal bypass)

Q103 : TDA8809T

pin	mnemonic	description
1	Vp	Positive supply voltage
2	Cosc1	Frequency setting capacitors for oscillator
3	Cosc2	
4	R _{wob}	Wobble generator input
5	R _{osc}	Biassing resistor for oscillator frequency and internal amplitude
6	$\overline{DIV4}$	Divide-by-4 input
7	REdig	Digital output of sign (Re2 - Re1)
8	B3	Input control bits for off-, catch-, play-status and DAC output current
9	B2	
10	B1	
11	B0	
12	V _{ext(+)}	Positive external voltage input
13	V _{ext(-)}	Negative external voltage input (also substrate connection)
14	GND	Negative supply connection
15	RADout	Current output of amplified (Re2 - Re1) input currents
16	REin	Radial error input
17	RE _{lag}	Voltage output of integrated (Re2 - Re1) input currents
18	Lag	Connection of integrator capacitor for (Re1 - Re2) input currents
19	Lead	Lead output
20	V _{ref}	Internal reference voltage output
21	AGC	Gain control input for radial error signal
22	RDAC	Biassing resistor for current output for track jumping (3½ bits)
23	offset in	Offset control input for radial offset
24	offset out	Offset control output for radial offset
25	C _L PF	Low-pass filter for Re1 and Re2, used for radial offset control
26	C _H PF	High-pass filter for Re1 and Re2, used for radial offset control
27	Re1	Input for amplified currents from photo-diodes D1 and D2
28	Re2	Input for amplified currents from photo diodes D3 and D4

Q501 : SAA7310 (1/3)

pin no.	mnemonic	description
QFP		
7 - 14	A0 - A7	Address: address outputs to external RAM.
15	$\overline{\text{RAS}}$	Row Address Select: output to external RAM (4416) which uses multiplexed address inputs.
16	$\text{R}/\overline{\text{W}}$	Read/Write: output signal to external RAM.
18	$\overline{\text{MUTE}}$	Mute: input from the microprocessor. When mute is LOW the data output DAAB, pin 37 (2), is attenuated to zero in 15 successive divide-by-2 steps. On the rising edge of mute the data output is incremented to the first 'good' value in 2 steps. This input has an internal pull-up of 50 k Ω (typ.).
19 - 21	D1 - D3	Data: data inputs/outputs to external RAM.
22	$\overline{\text{CAS}}$	Column Address Select: output signal to external RAM.
23	D4	Data: data input/output to external RAM.
24	MSC	Motor Speed Control: open drain output which provides a pulse width modulated signal with a pulse rate of 88 kHz to control the rate of data entry. The duty factor varies from 1,6% to 98,4% in 62 steps. When a motor-start signal is detected via pin 33 (42) (SWAB/SSM) the duty factor is forced to 98,4% for 0,2 seconds followed by a normal calculated signal. After a motor-stop signal is detected the duty factor is forced to 1,6% for 0,2 seconds, followed by a continuous 50% duty factor.
25	XTAL2	Crystal oscillator output: drive output to clock crystal (11,2896 MHz typ.).
26	XTAL1	Crystal oscillator input: input from crystal oscillator or slave clock.
27	VSS	Ground: circuit earth potential.
28	VDD	Power Supply: positive supply voltage (+ 5 V).
29	PD/OC	Phase Detector output/ Oscillator Control input: outputs of the frequency detector and phase detector are summed internally, then filtered at this pin to provide the frequency control signal for the VCO.
30	I_{ref}	Current reference: external reference input to the phase detector and data slicer. This input is required to minimize the spread in the charge pump output of the phase detector and data slicer.
31	FB	Feedback: output from the input data slicer. This output is a current source of 100 μA (typ.) which changes polarity when the level detector input HFI at pin 25 (32) rises above the threshold voltage of 2 V (typ.). When a data run length violation is detected (e.g. during drop out), or when HFD at pin 26 (34) is LOW, this output goes to a high impedance state.

Q501 : SAA7310 (2/3)

pin no.	mnemonic	description
QFP		
32	HFI	High-Frequency Input: level detector input to the data slicer. A differential signal of between 0,5 and 2,5 V (peak-to-peak value) is required to drive the data slicer correctly. When a T_{max} violation is detected or when HFD is LOW, this input is biased directly to its threshold voltage
34	HFD	High-Frequency Detector: when HIGH this input signal enables the frequency and phase detector inputs, also the feedback output (FB) from the data slicer. An internal voltage clamp of 3 V (typ.) requires the HFD input to be fed via a high impedance. This input has an internal pull-up of 50 k Ω (typ.).
35	$\overline{\text{AM}}$	Additional Mute: This pin is normally held HIGH. Should track loss occur the pin should be taken LOW and then the data is forced LOW at the pre-FIFO stage. The muted data will then be corrected after de-interleaving. Note With DINT2, DEEM/ $\overline{\text{DINT1}}$, FB set to logic 0 and SDAB, SCAB set to logic 1, this pin becomes the demodulator clock output (CEFM) of the SAA7210 (CD2A).
36	$\overline{\text{CRI}}$	Counter Reset Inhibit: when LOW this input signal allows the divide-by-588 master counter in the DEMOD timing to run-free. This input has an internal pull-up of 50 k Ω (typ.).
37	QDATA	Q-channel Data: this subcoding output is parity checked and changes in response to the Q-channel clock input (see subcoding microprocessor handshaking protocol).
38	QRA	Q-channel Request input/Acknowledge output: the output has an internal pull-up of nominally 10 k Ω . (see subcoding microprocessor handshaking protocol).
40	QCL	Q-channel Clock: clock input generated by the microprocessor when it detects a QRA LOW signal.
41	DEEM/ $\overline{\text{DINT1}}$	De-emphasis output and data interpolated input: signal derived from one bit of the parity-checked Q-channel and fed out via the debounce circuit in DEEM mode. When using the CD3A in a non-digital audio application this pin should be set HIGH (with DINT2 set LOW) to prevent data being interpolated. Note This pin should only be used in its input mode when DINT2 is LOW.
42	SWAB/SSM	Subcoding Word clock output and Start/Stop Motor input: open drain output which is sensed during each HIGH period and if externally forced LOW a motor-stop condition will be decoded and fed to the motor control logic circuit. When allowed to return HIGH, the motor will start. This open-drain output has an internal pull-up of 10 k Ω (typ.).

Q501 : SAA7310 (3/3)

pin no.	mnemonic	description
QFP		
43	SDAB	Subcoding Data: a 10-bit burst of data, including flags and sync bits, is output serially once per frame clocked by burst clock output SCAB (see Fig. 6).
44	SCAB	Subcoding Clock: a 10-bit burst clock 2,8224 MHz (typ.) output which is used to synchronize the subcoding data.
1	EFAB	Error Flag: output from interpolation and mute circuit indicating unreliable data.
2	DAAB	Data: this output together with its clock (CLAB) and word select (WSAB) outputs, conforms to the I ² S bus format (see Fig. 7).
3	CLAB	Clock: I ² S output.
4	WSAB	Word Select: I ² S output.
5	DINT2	Data interpolated input: this pin should normally be set HIGH. When using the CD3A in a non-digital audio application this pin should be set LOW (with DEEM/DINT1 set HIGH) to prevent data being interpolated.
6	TEST1	Test output 1
17	TEST2	Test output 2
33	TEST3	Test output 3
39	TEST4	Test output 4

Note to the pin functions

The pin sequence of the address outputs (A0 - A7) and the data outputs (D1 - D4) has been selected to be compatible with various dynamic 16 K x 4-bit RAMs including the 4416.

Q504 : PCF3523P

pin no.	mnemonic	i/o description
1	WSAB	I Word Select: I2S input.
2	CLAB	I Clock: I2S input.
3	DAAB	I Data: I2S input.
4	EFAB	I Error Flag: Indicating unreliable data when high. Copied to the validity bit in the DOBM output signal.
5	FS44	I Sampling Frequency in channel status block: 44.1 KHz when this input is HIGH, 32 KHz when LOW. This input has an internal pull-up.
6	SCAB	I Subcode Clock: 10 bit burst clock which synchronizes subcode data. Alternative function: control bit 2 of channel status block.
7	SDAB	I Subcode Data: 10 bit burst data. Alternative function: control bit 3 of channel status.
8	VSS	Ground: circuit earth potential.
9	XIN	I Crystal oscillator input from crystal oscillator or slave clock.
10	XOUT	O Crystal clock drive output to clock crystal.
11	XSYS	O System clock output: 256 x Fs.
12	TESTB	I Test input: HIGH for normal operation. This input has an internal pull-up.
13	DOBM	O Digital Audio Output: biphas modulated signal.
14	DOEN	I Digital Output ENable: disables DOBM (continuously LOW) when LOW (standby). This input has an internal pull-up.
15	ATSB	I Attenuation: when active LOW this control input provides -12 dB attenuation. This input has an internal pull-up.
16	VDD	Power supply: positive supply voltage (+5V).

Q561 : SAA7350GP (1/2)

Pin No.	mnemonic	description
1	XSEL	Crystal frequency select. This pin is used to select the master crystal frequency as follows:- XSEL HIGH = 384fs XSEL LOW = 256fs This pin defaults to XSEL HIGH when not connected.
2	DOEN	One-bit Digital Output Enable. When LOW, the one-bit code outputs are made available for TDA1547 (DAC7). If unconnected the pin will default HIGH.
3	IDF3	Input data format. These three pins determine the input format the device is to operate in (see functional description). If unconnected these pins will default HIGH (i.e. burst clock mode).
4	IDF2	
5	IDF1	
6	TEST4	Test 4: This pin should be left open circuit.
7	SDI2	Serial Data Input. Used in simultaneous mode only (for the right channel signal). When not used, this pin will be internally pulled high.
8	SDI1	Serial Data Input. This should be a 16, 18 or 20-bit linear 2's complement PCM signal. In simultaneous mode this pin is used for the left channel signal.
9	WSI	Serial input Word Select signal. Signifies whether data word is for the left or right channel. Can be either fs, 2fs, 4fs or 8fs where fs is the system sampling frequency. fs can lie between 16kHz and 53kHz.
10	SCKI	Bit clock input for the serial input interface.
11	TEST1	Test 1. This pin should be left open circuit.
12	VDD	+5V power supply for the digital section.
13	VSS	Ground connection for the digital section.
14	XIN	Crystal Oscillator Input.
15	XOUT	Crystal Oscillator Output.
16	XSYS1	Buffered Oscillator Output.
17	TEST5	Test 5. In normal operation this pin should be tied LOW.
18	VDDAR	Analogue 5V supply for right channel.
19	INTR+	Output from the Right Positive switched-capacitor integrator. Input to differential op-amp.
20	FBR+	Feedback connection for the Right positive switched-capacitor integrator.
21	VSSAR	0V supply for right channel.
22	FBR-	Feedback connection for the Right Negative switched-capacitor integrator.
23	INTR-	Output from the Right Negative switched-capacitor integrator. Input to differential op-amp.
24	VROR	High impedance voltage reference for right channel inputs. Typically VDDAR/2.

Q561 : SAA7350GP (2/2)

Pin No.	mnemonic	description
25	VDACR	Reference Voltage Supply for Right channel DAC's. Normally this will be connected to VSS.
26	VROR	Right channel Voltage Reference Output. Typically VDDAR/2.
27	VDDATR	5V supply for right channel analogue timing.
28	VSSAT	0V supply for left and right channel analogue.
29	VDDATL	5V supply for left channel analogue timing.
30	IRR	24kohm bias resistor connection for the reference current generator circuit.
31	VROL	Left channel Voltage Reference Output. Typically VDDAL/2.
32	VDACL	Reference Voltage Supply for Left channel DAC. Normally this will be connected to VSS.
33	VRCL	High impedance voltage reference for left channel inputs and for bias current generator. Typically VDDAL/2.
34	INTL-	Output from the Left Negative switched-capacitor integrator. Input to differential op-amp.
35	FBL-	Feedback connection for the Left Negative switched-capacitor integrator.
36	VSSAL	0v supply for left channel.
37	FBL+	Feedback connection for the Left Positive switched-capacitor integrator.
38	INTL+	Output from the Left Positive switched-capacitor integrator. Input to differential op-amp.
39	VDDAL	Analogue 5V supply for left channel.
40	TEST2	Test 2: This pin should be left open circuit.
41	TEST3	Test 3: This pin should be left open circuit.
42	DOL	Digital Output Left. Left channel one-bit code for TDA1547 (DAC7), when disabled this pin will be driven LOW.
43	XSYS2	Output clock at a frequency of half the master clock frequency.
44	DOR	Digital Output Right. Right channel one-bit code for TDA1547 (DAC7). When disabled this pin will be driven LOW.

Q563 : SM5803AP

PIN No.	NAME	I/O *1	DESCRIPTION
1	DIN	Ip	Serial data input
2	BCKI	Ip	Timing clock for serial input data (Bit clock)
3	CKSL	Ip	Selecting system clock *2
4	CKDV	Ip	↑
5	\overline{BX}	Ip	Selecting over sampling H: 4fs L: 8fs
6	XTI	I	Input for oscillator or external clock input (System clock)
7	XTO	O	Output for oscillator. No connect when using external clock
8	V _{SS1}	—	Ground 1
9	CKO	O	Clock output (Same frequency as XT1 input clock)
10	MS1	Ip	Mode set control 1
11	MS2	Ip	Mode set control 2
12	MS3	Ip	Mode set control 3
13	MDT	Ip	Mode set data
14	\overline{MEN}	Ip	Mode set enable
15	MUTE	Ip	Mute control H: Mute on L: Mute off
16	DIEM	Ip	Digital de-emphasis control H: De-emphasis on L: De-emphasis off
17	FSEL1	Ip	Selecting digital de-emphasis filter characteristics *3
18	FSEL2	Ip	↑
19	DGR	O	8fs dual output mode: Deglitch signal (Negative output) 4fs dual output mode: ↑ 4fs alternate output mode: Deglitch signal (Rch)
20	DGL	O	8fs dual output mode: Deglitch signal (Positive output) 4fs dual output mode: ↑ 4fs alternate output mode: Deglitch signal (Lch)
21	V _{SS2}	—	Ground 2
22	V _{DD}	—	Supply voltage (-5V)
23	DOR	O	8fs dual output mode: Rch data output 4fs dual output mode: ↑ 4fs alternate output mode: Multiplex clock for L/R output data
24	DOL	O	8fs dual output mode: Lch data output 4fs dual output mode: ↑ 4fs alternate output mode: Lch/Rch data output
25	WCKO	O	Output timing control (Word clock)
26	BCKO	O	Output timing control for serial data (Bit clock)
27	FSCO	O	Internal timing clock (fs rate)
28	LRCI	Ip	Multiplex clock for Lch/Rch input data (fs rate) H: Lch L: Rch

*1) I : Input terminal
Ip : Input terminal with pull-up resistance
O : Output terminal

*2)

CKSL	CKDV	System clock (Input to XT1)
H	H	192fs
H	L	384fs
L	H	256fs
L	L	512fs

*3)

FSEL1	FSEL2	Characteristics of de-emphasis
H	H	fs = 32 kHz
L	L	fs = 44.1 kHz
L	H	fs = 48 kHz

QD01, QD02 : TDA1547

PIN No.	NAME	DESCRIPTION
1	diggnd	0V digital supply
2	vdddig	5V digital supply for both channels
3	datchr	serial one-bit data input for the right channel
4	n.c.	pin not connected, should preferably be connected to digital ground
5	clklnr	clock input for the right channel
6	vdddigr	5V digital supply for the right channel. This voltage determines the internal logic high level in the right channel.
7	vssdigr	-3.5V digital supply for the right channel. This voltage determines the internal logic low level in the right channel.
8	vrefr	-4V reference voltage for the right channel switch capacitor DAC.
9	agnddacr	0V reference voltage for the right channel switch capacitor DAC. This pin should be connected to analog ground.
10	outdnr	output from the right negative switch capacitor DAC. Feedback connection for the right negative opamp
11	outdr	output from the right positive switch capacitor DAC. Feedback connection for the right positive opamp.
12	agndopar	0V reference voltage for both right channel opamps.
13	n.c.	pin not connected, should preferably be connected to analog ground.
14	outopar	output of right positive opamp
15	outnpar	output of right negative opamp.
16	vssanl	-5V analog supply
17	vddanl	5V analog supply
18	outnopal	output of left negative opamp.
19	outopal	output of left positive opamp.
20	n.c.	pin not connected, should preferably be connected to analog ground.
21	agndopal	0V reference voltage for both left channel opamps
22	outdl	output from the left positive switch capacitor DAC. Feedback connection for the left positive opamp.
23	outcni	output from the left negative switch capacitor DAC. Feedback connection for the left negative opamp
24	agnddac1	0V reference voltage for the left channel switch capacitor DAC. This pin should be connected to analog ground.
25	vrefl	-4V reference voltage for the left channel switch capacitor DAC.
26	vssdigl	-3.5V digital supply for the left channel. This voltage determines the internal logic low level in the left channel
27	vdddigl	5V digital supply for the left channel. This voltage determines the internal logic high level in the left channel.
28	clklnr	clock input for the left channel
29	n.c.	pin not connected, should preferably be connected to digital ground
30	datchl	serial one-bit data input for the right channel
31	vssdig	-5V digital supply for both channels
32	sub	-5V substrate

MEMO

3 BLOCK DIAGRAM

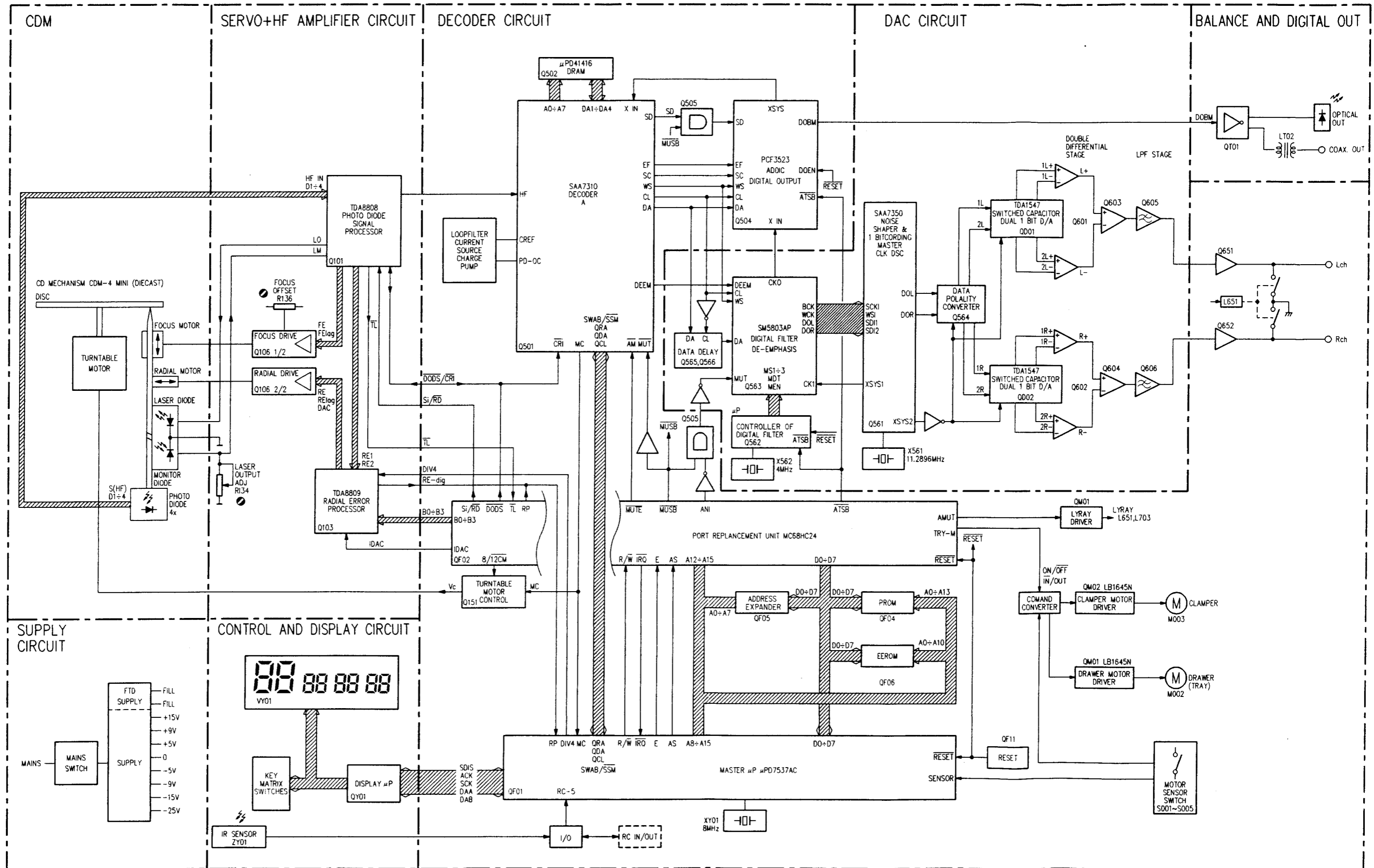

4 SCHEMATIC DIAGRAM AND PARTS LOCATIONS (PATTERN SIDE)

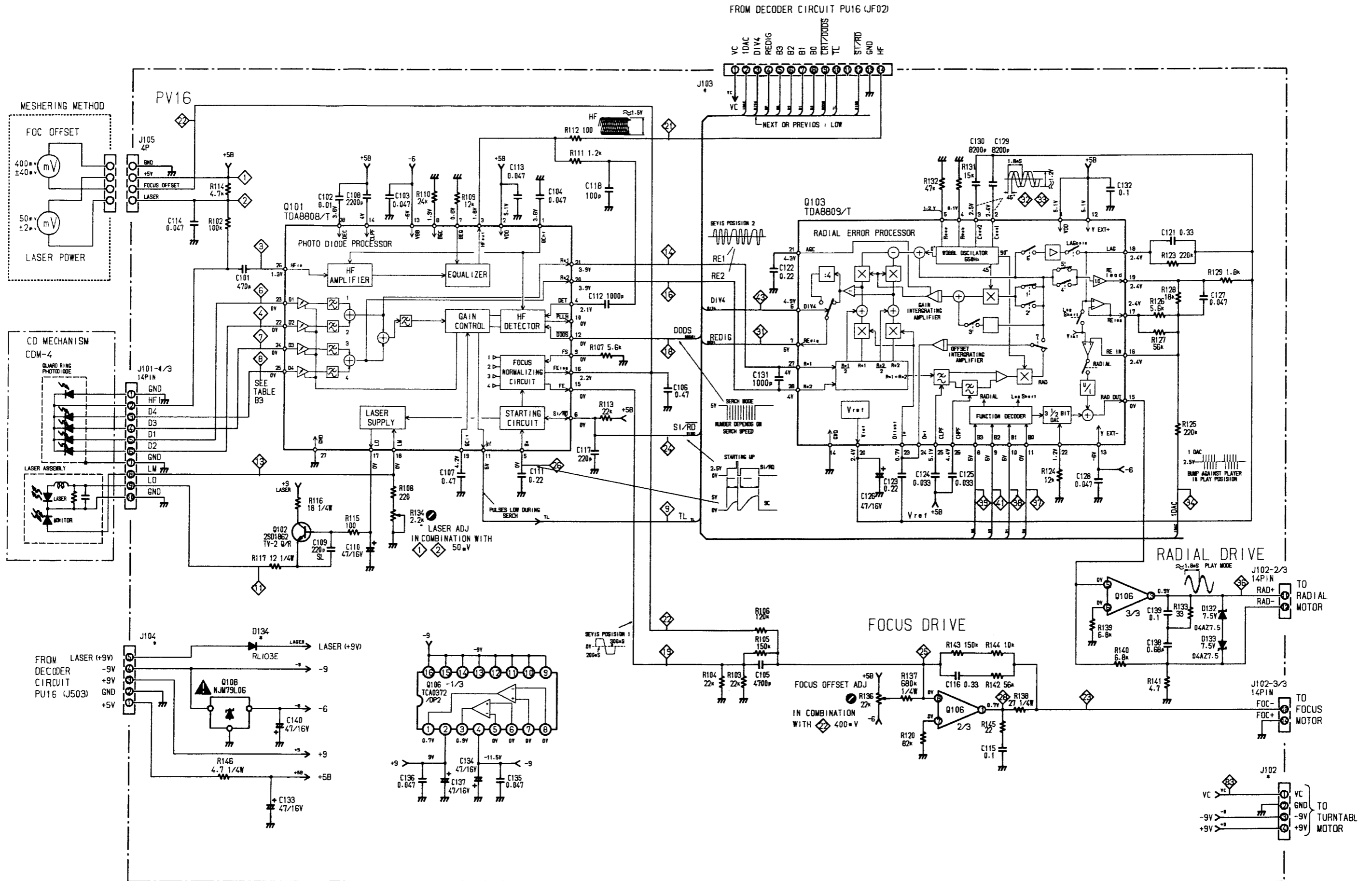

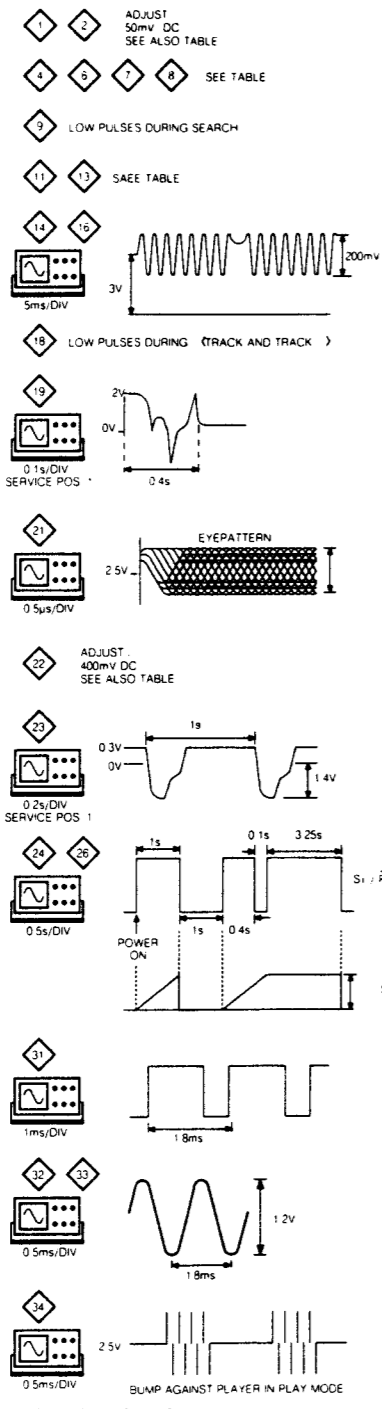

SERVICE POSITION 0		PLAY MODE	
((SEARCH+))		SEARCH	
B3	HIGH	HIGH	ACTIVITY
B2	HIGH	LOW	ACTIVITY
B1	HIGH	HIGH	ACTIVITY
B0	LOW	LOW	ACTIVITY

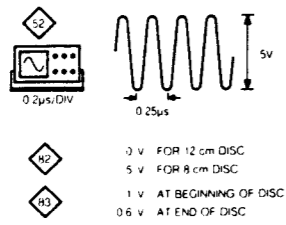

PV16 SERVO

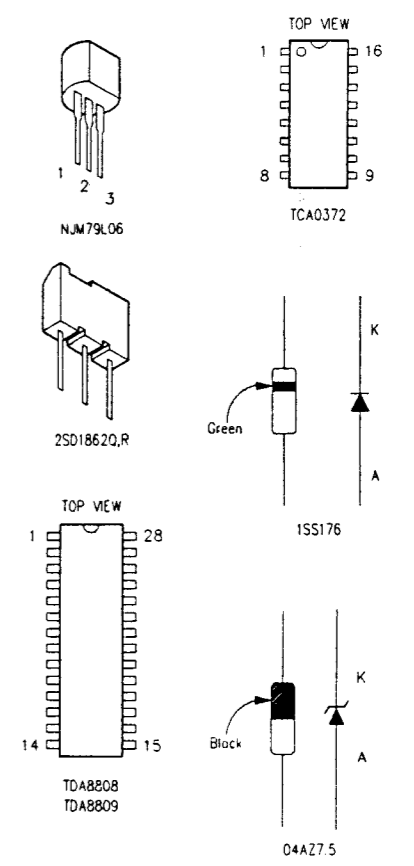
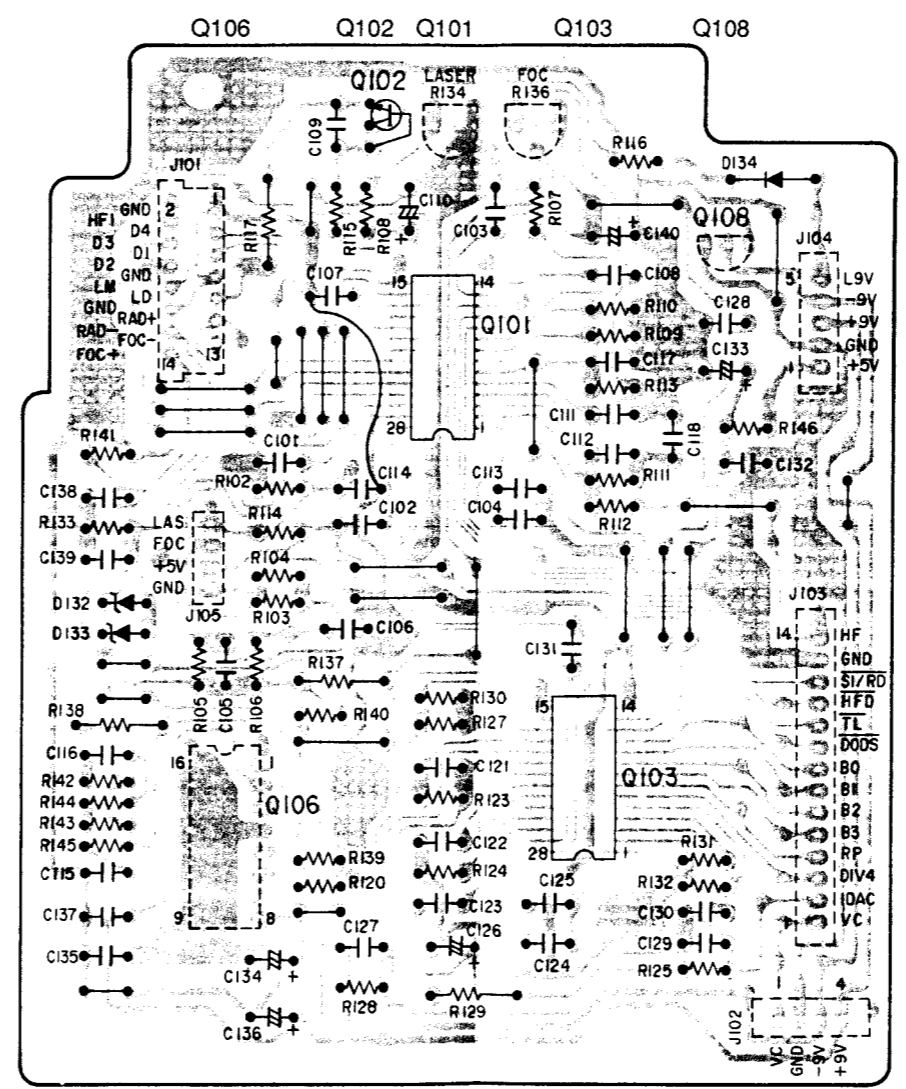

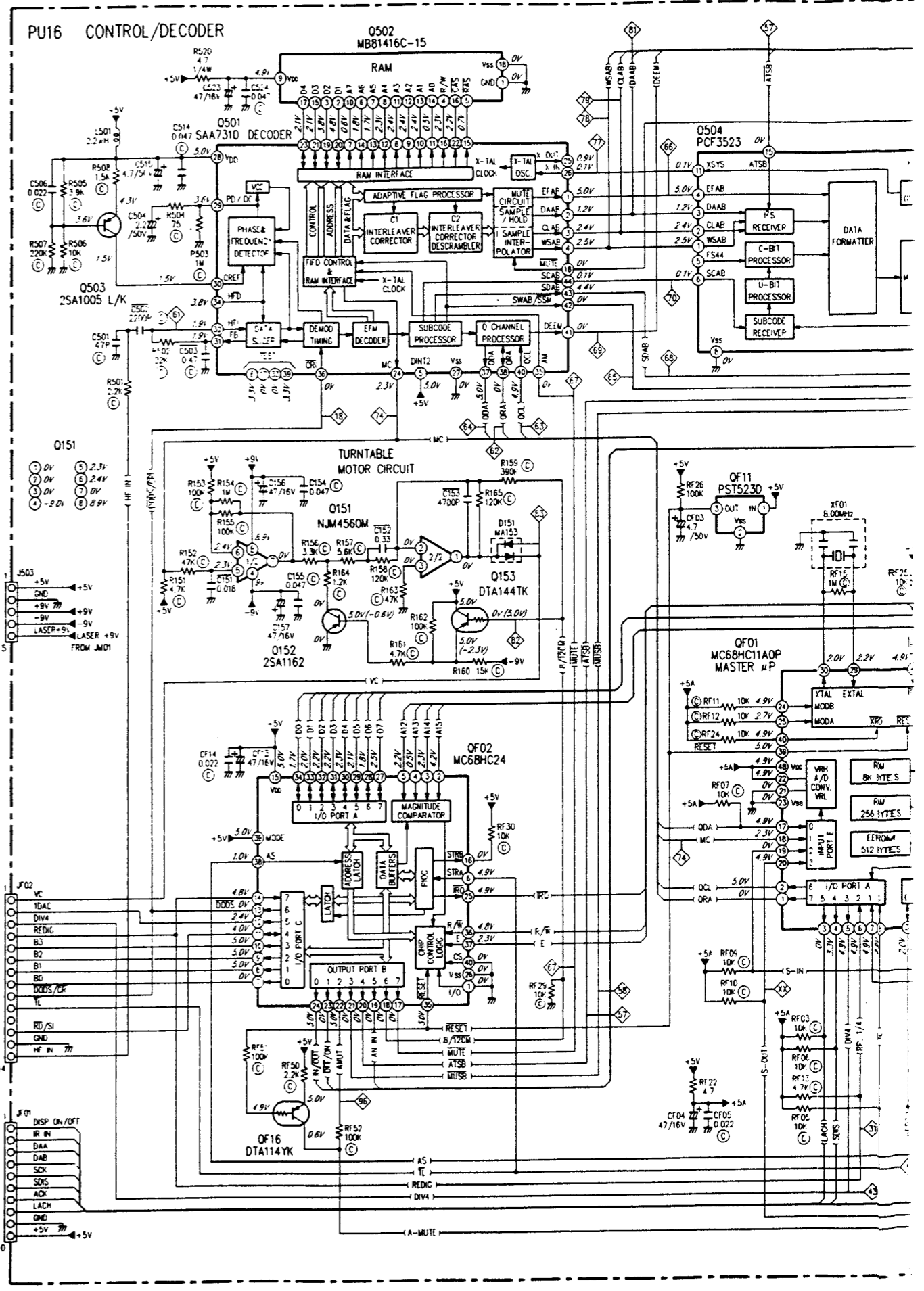
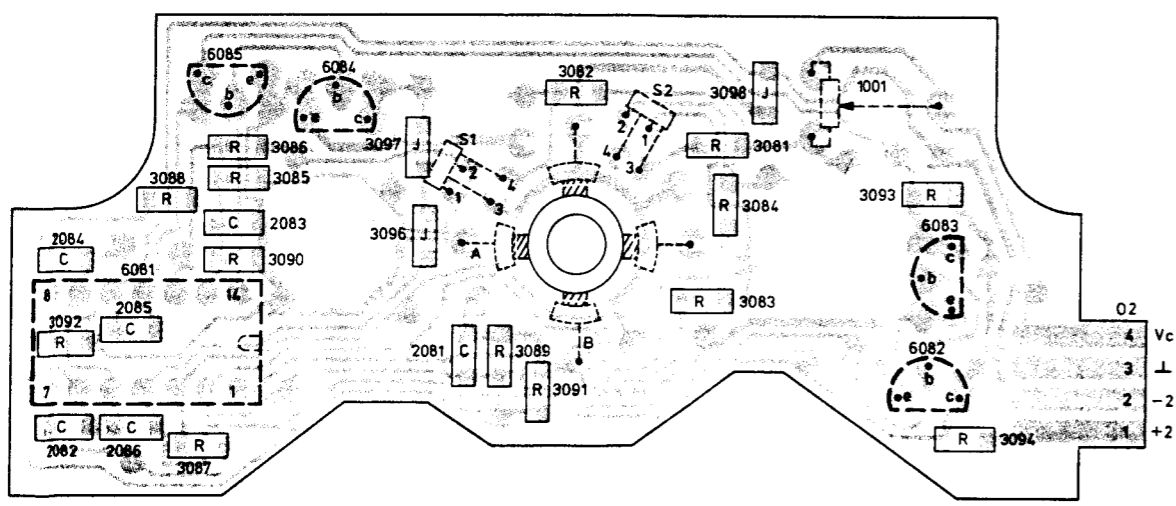
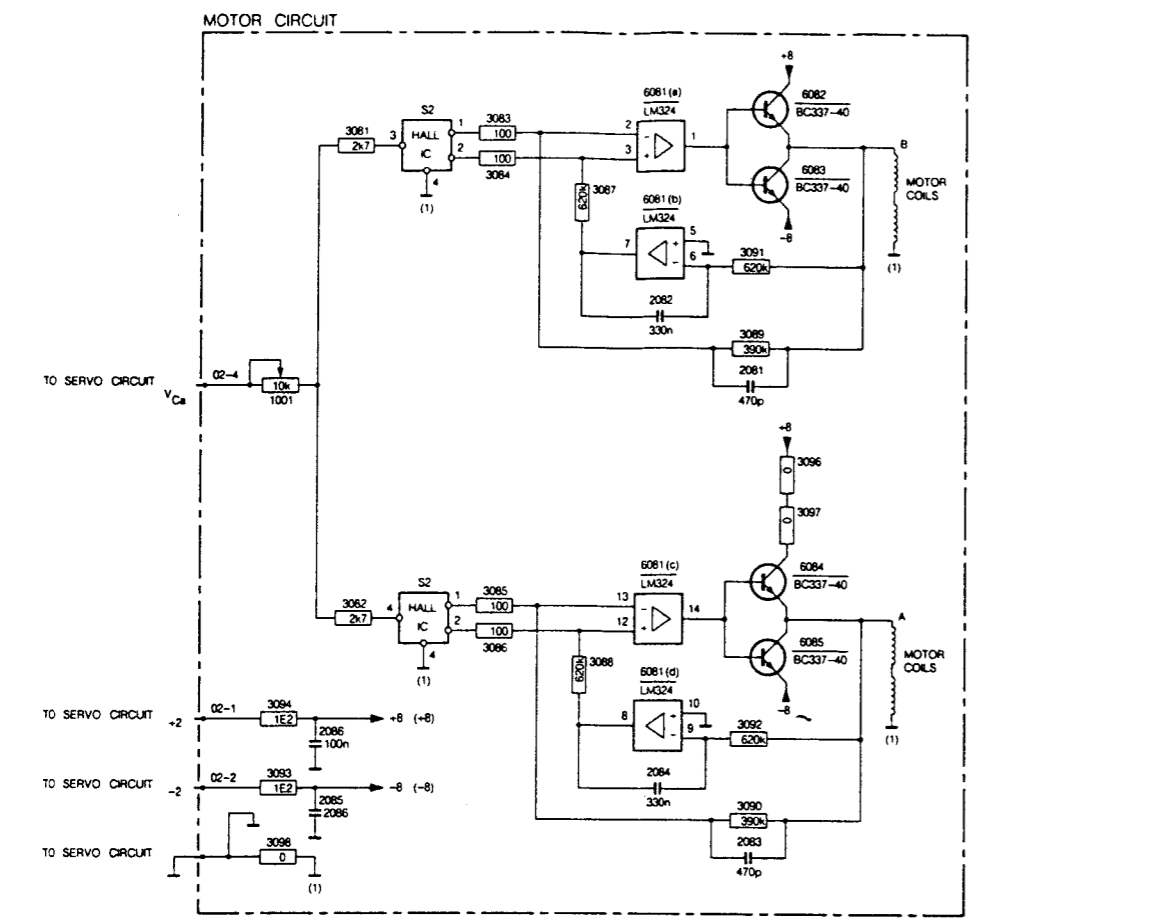

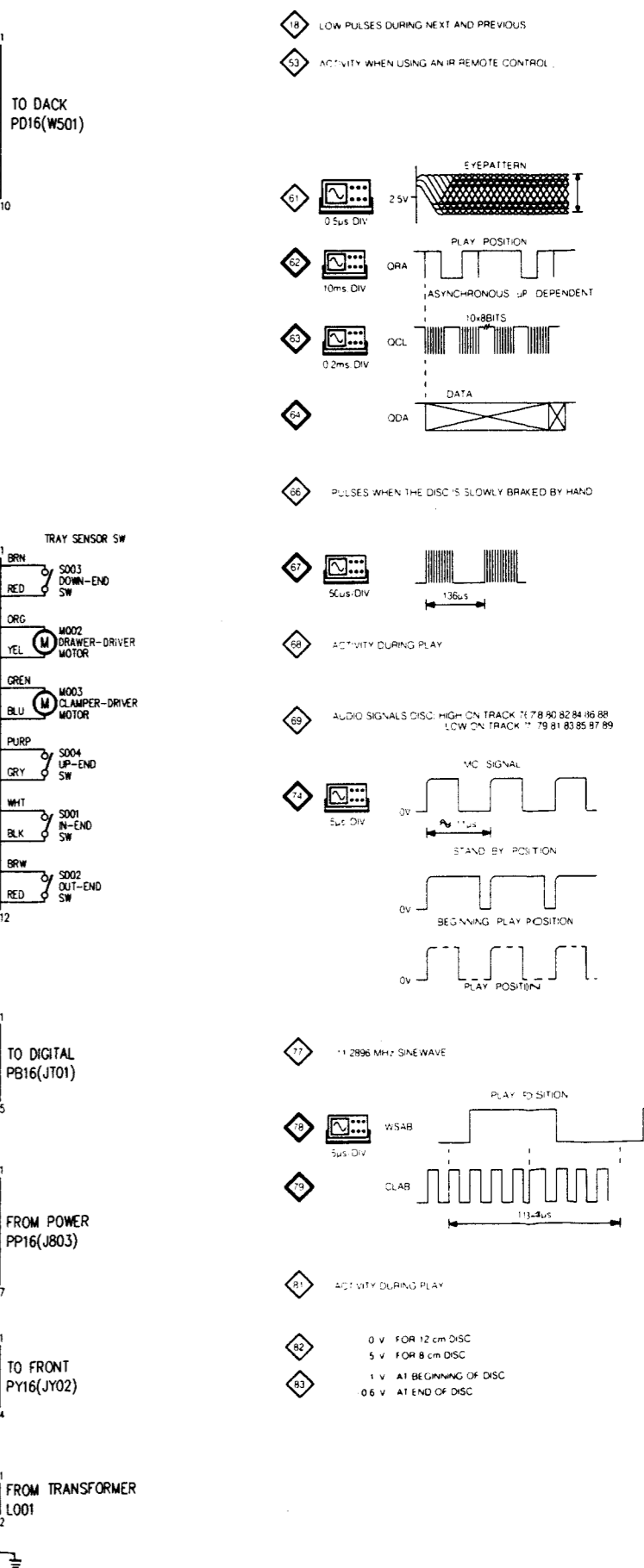
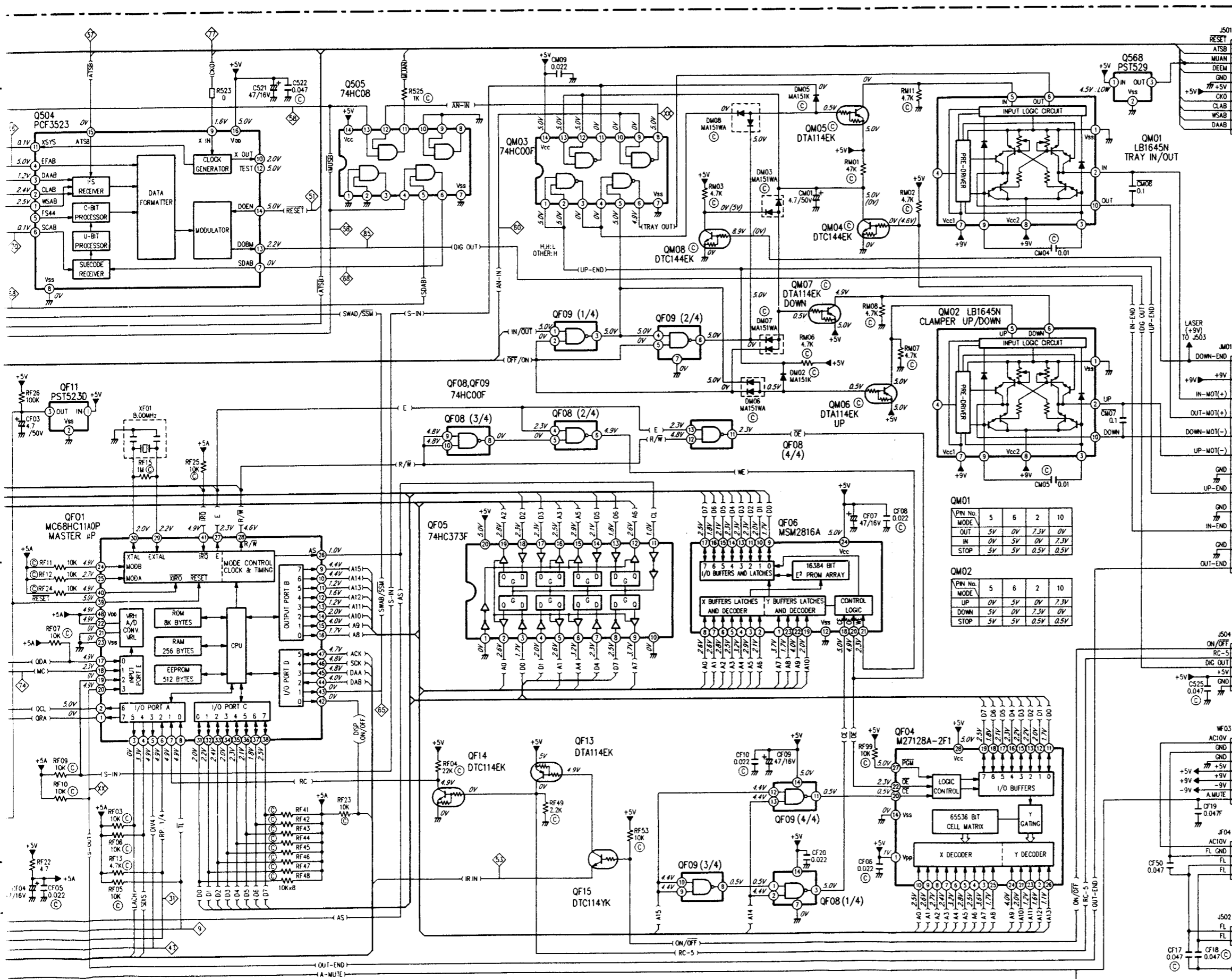



PST523D
PST529
2SA1005L/K

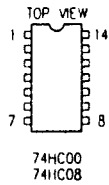

74HC00
74HC08

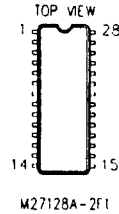

M27128A-2F1

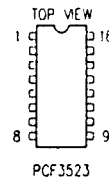

PCF3523

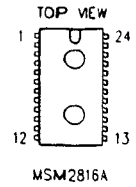

MSM2816A

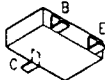

DTA114YK, DTA114EK
DTC144EK, DTC114EK
DTA144TK, 2SA1162

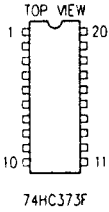

74HC373F

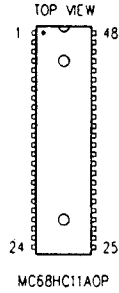

MC68HC11AOP

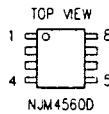

NJM4560D

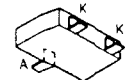

MA153
MA151WA
MAT51K

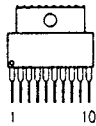

LB1645N

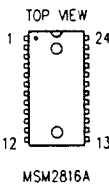

MSM2816A

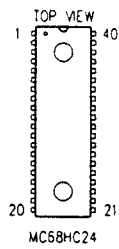

MC68HC24

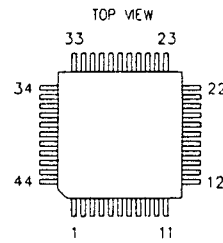

SAA7310

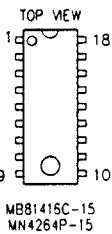

MB81416C-15
MN4264P-15

TIMING CHART

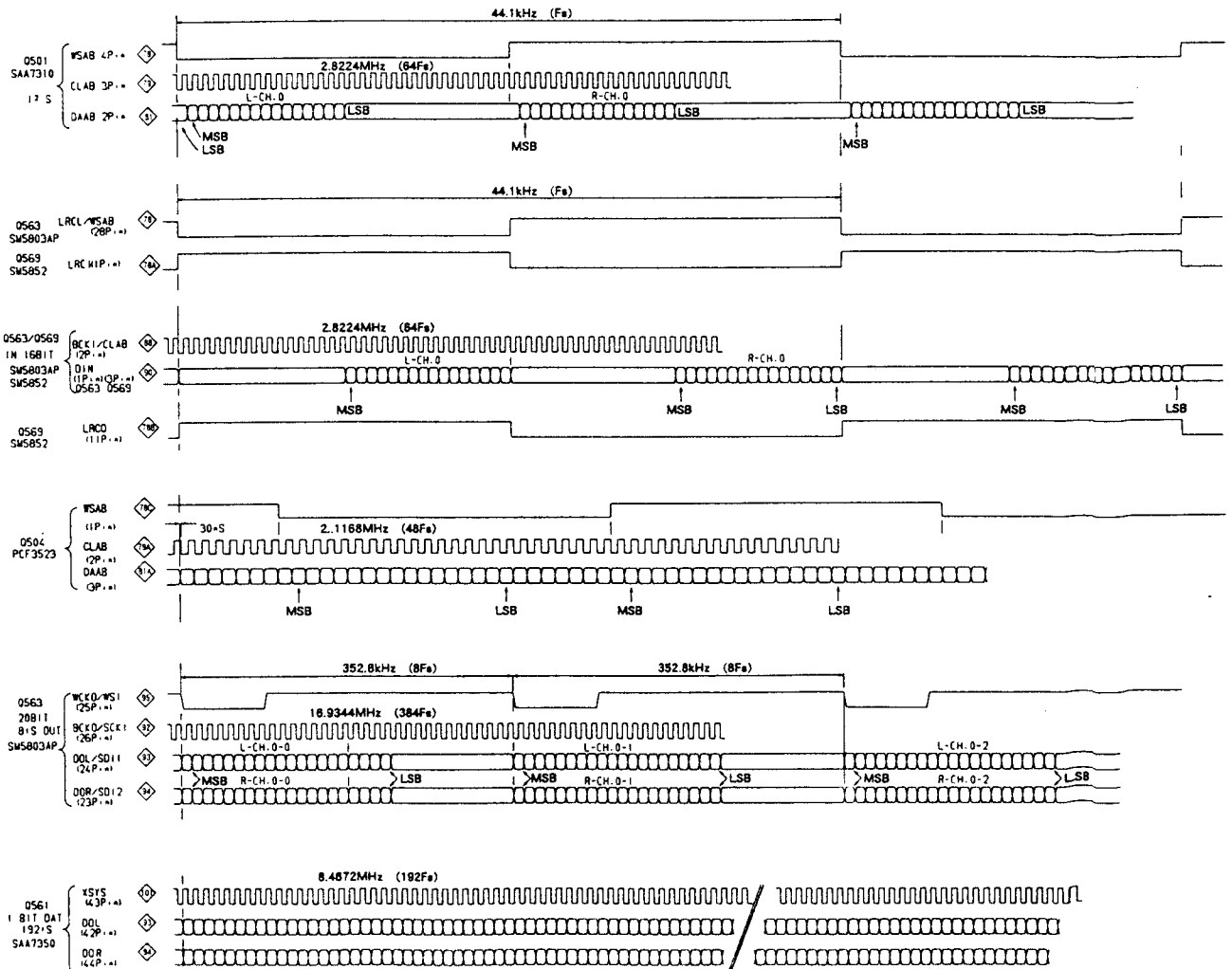

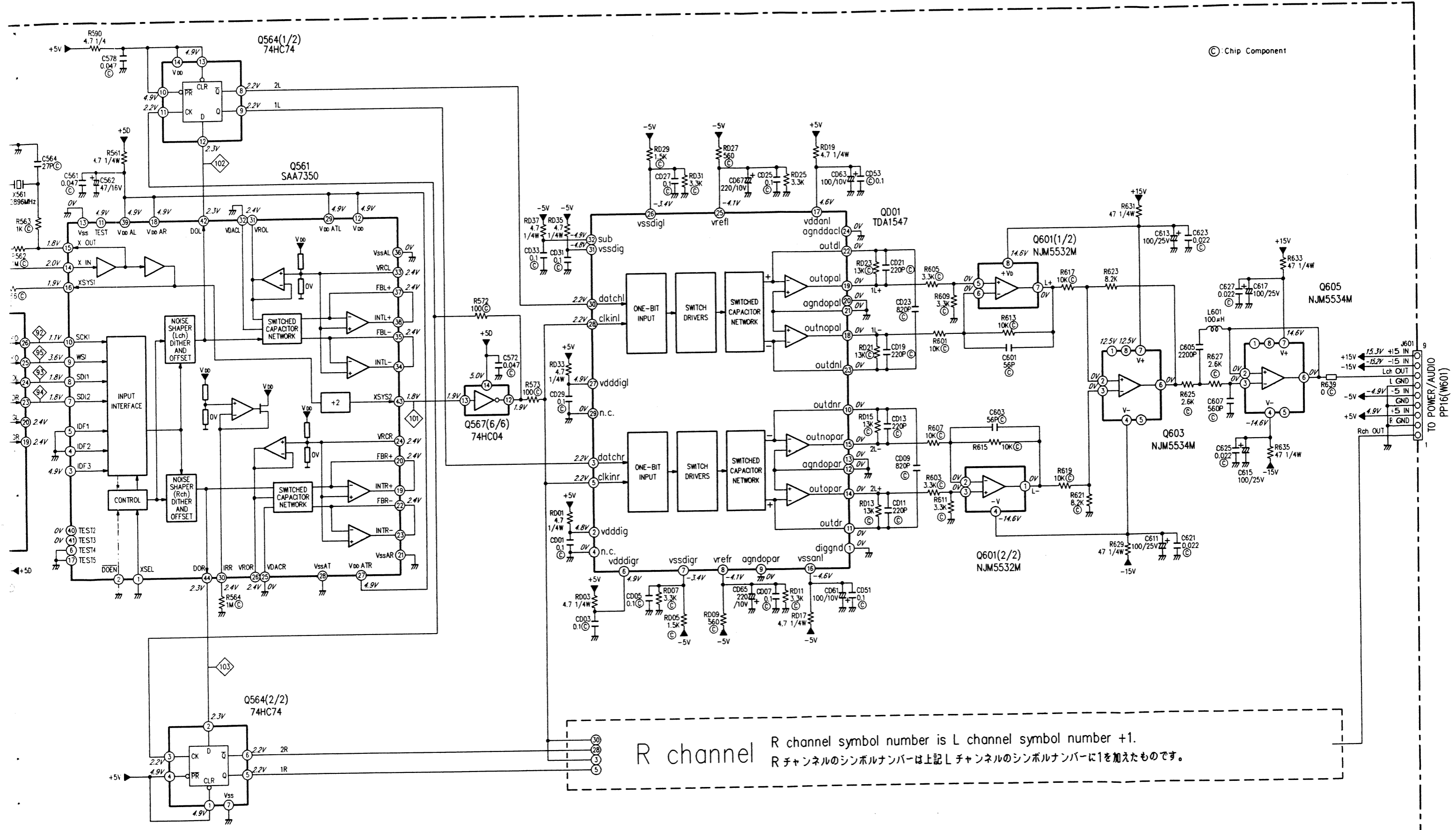

© Chip Component

R channel R channel symbol number is L channel symbol number +1.
 Rチャンネルのシンボルナンバーは上記Lチャンネルのシンボルナンバーに1を加えたものです。

PD16 DAC (COMPONENT SIDE)

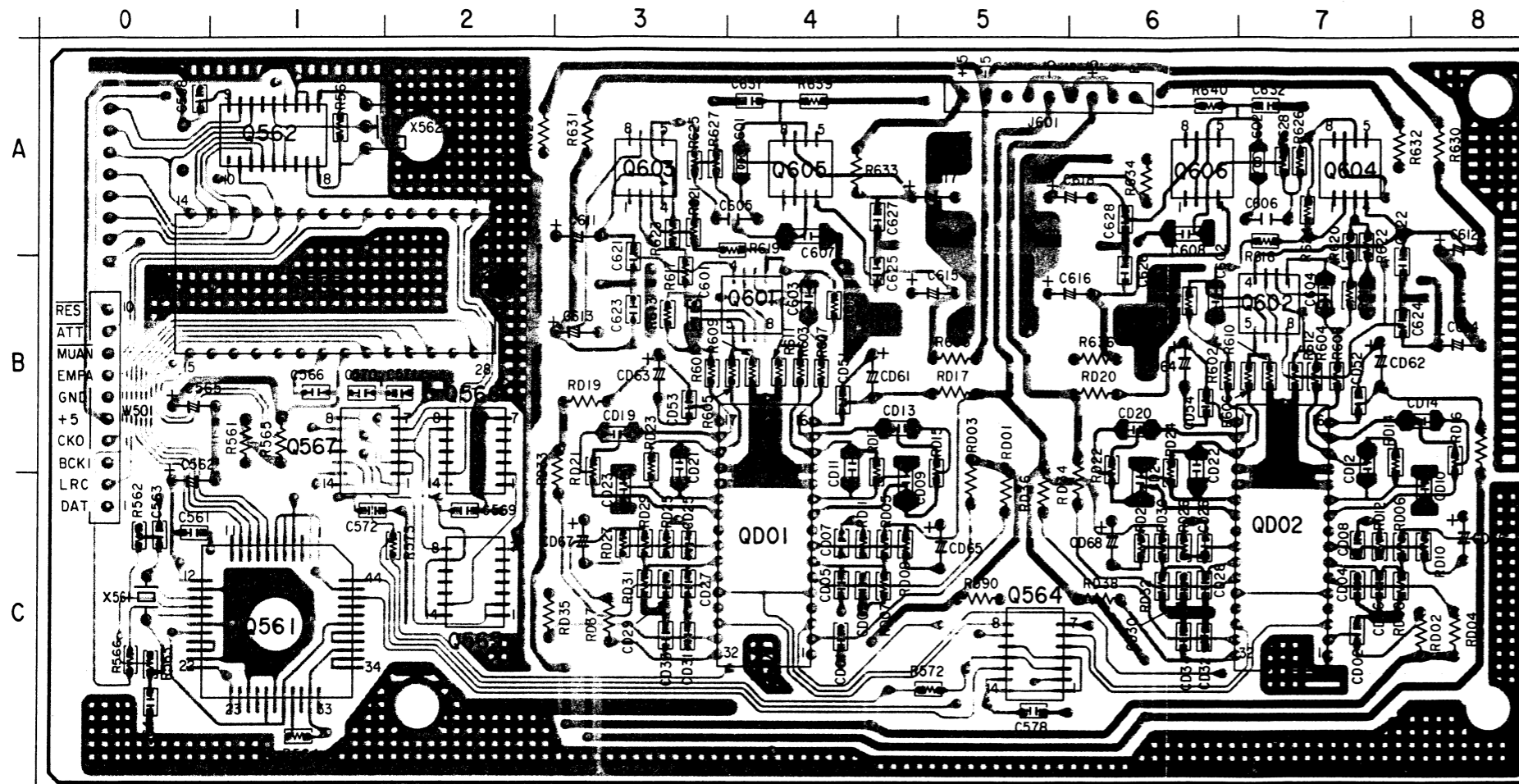

CD01 C4	C611 A3	RD28 C6
CD02 C7	C612 A8	RD29 C3
CD03 C4	C613 B3	RD30 C6
CD04 C7	C614 B8	RD31 C3
CD05 C4	C615 B5	RD32 C6
CD06 C7	C616 B5	RD33 B2
CD07 C4	C617 A5	RD34 B6
CD08 C7	C618 A5	RD35 C2
CD09 B5	C621 A3	RD36 C5
CD10 C8	C622 A7	RD37 C3
CD11 B4	C623 B3	RD38 C6
CD12 B7	C624 B7	R561 B1
CD13 B4	C625 A4	R562 C0
CD14 B8	C626 A6	R563 C0
CD19 B3	C627 A4	R564 C1
CD20 B6	C628 A6	R565 B1
CD21 B3	C631 A4	R566 C0
CD22 B6	C632 A7	R569 A1
CD23 C3	J601 A5	R572 C5
CD24 B6	L601 A4	R573 C2
CD25 C3	L602 A7	R590 C5
CD26 C6	QD01 C4	R601 B3
CD27 C3	QD02 C7	R602 B6
CD28 C6	Q561 C1	R603 B4
CD29 C3	Q562 A1	R604 B7
CD30 C6	Q563 B1	R605 B3
CD31 C3	Q564 C5	R606 B7
CD32 C6	Q565 C2	R607 B4
CD33 C3	Q566 B2	R608 B7
CD34 C6	Q567 B1	R609 B4
CD51 B4	Q601 B4	R610 B7
CD52 B7	Q602 B7	R611 B4
CD53 B3	Q603 A3	R612 B7
CD54 B6	Q604 A7	R613 B3
CD61 B4	Q605 A4	R614 B6
CD62 B7	Q606 A6	R615 B4
CD63 B3	RD01 C5	R616 B7
CD64 B6	RD02 C8	R617 A3
CD65 C5	RD03 B5	R618 A7
CD66 C8	RD04 C8	R619 A3
CD67 C3	RD05 C4	R620 A7
CD68 C6	RD06 C7	R621 A3
C561 C0	RD07 C4	R622 A7
C562 C0	RD08 C7	R623 A3
C563 C0	RD09 C5	R624 A7
C564 C0	RD10 C8	R625 A3
C565 B0	RD11 C4	R626 A7
C566 B1	RD12 C7	R627 A3
C567 A0	RD13 B4	R628 A7
C568 A0	RD14 B7	R629 A2
C569 C2	RD15 B5	R630 A8
C570 B1	RD16 B8	R631 A3
C571 B2	RD17 B5	R632 A7
C572 C1	RD18 B8	R633 A4
C578 C5	RD19 B3	R634 A6
C601 B3	RD20 B6	R635 B5
C602 B6	RD21 B3	R636 B6
C603 B4	RD22 B6	R639 A4
C604 B7	RD23 B3	R640 A6
C605 A3	RD24 B6	W501 B0
C606 A6	RD25 C3	X561 C0
C607 A4	RD26 C6	X562 A1
C608 A6	RD27 C3	

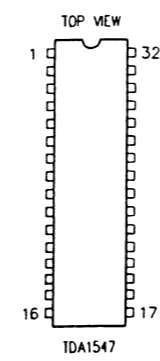
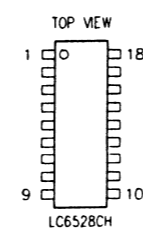
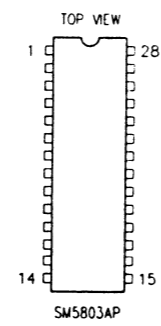
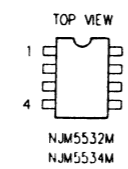
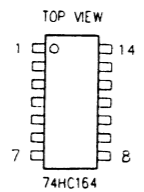
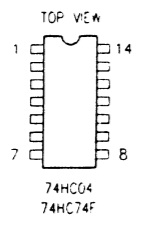
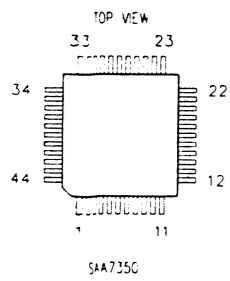

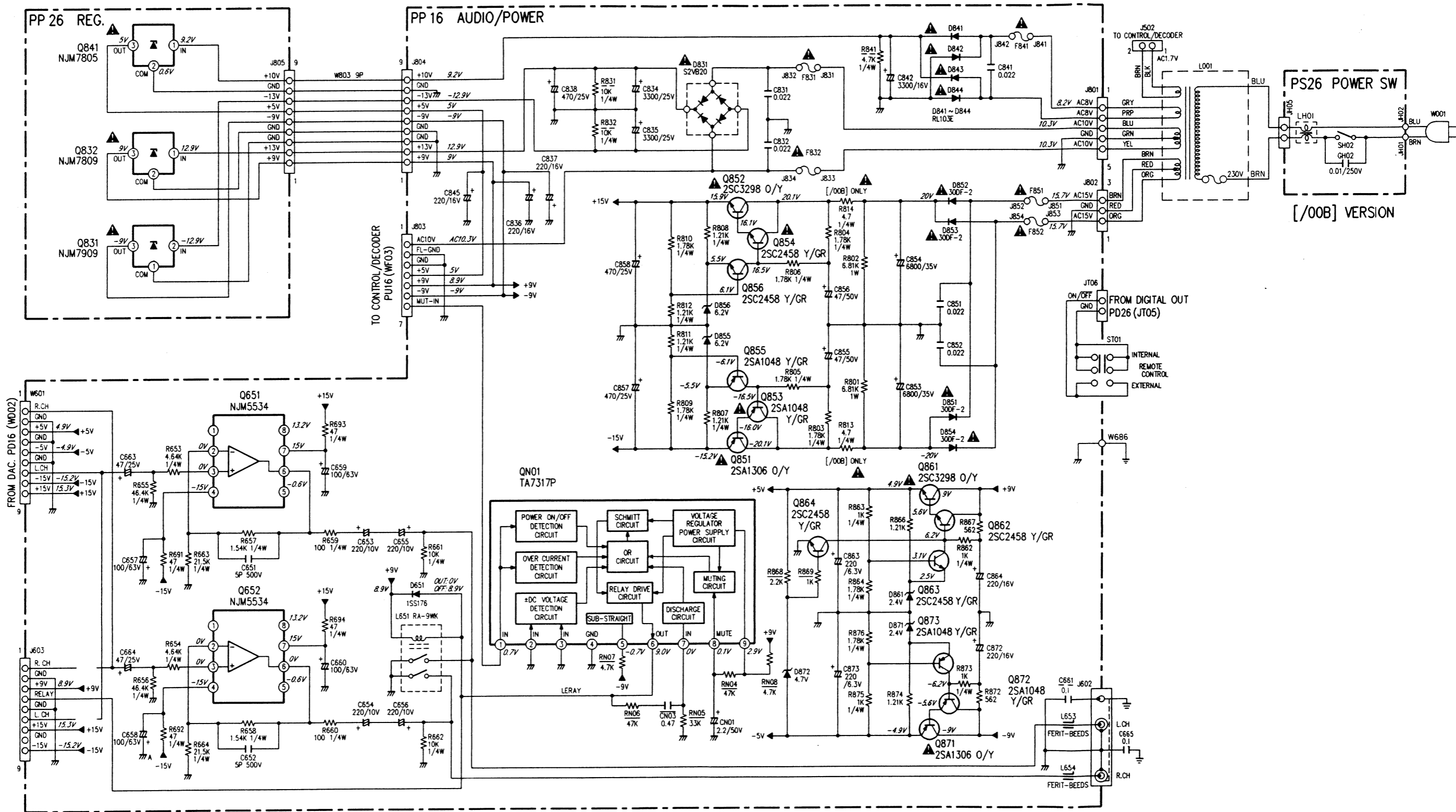

NOTE ON SAFETY:
 Symbol ▲ Fire or electrical shock hazard. Only original parts should be used to replace any part marked with symbol ▲. Any other component substitution (other than original type), may increase risk of fire or electrical shock hazard.

PP16 POWER/AUDIO

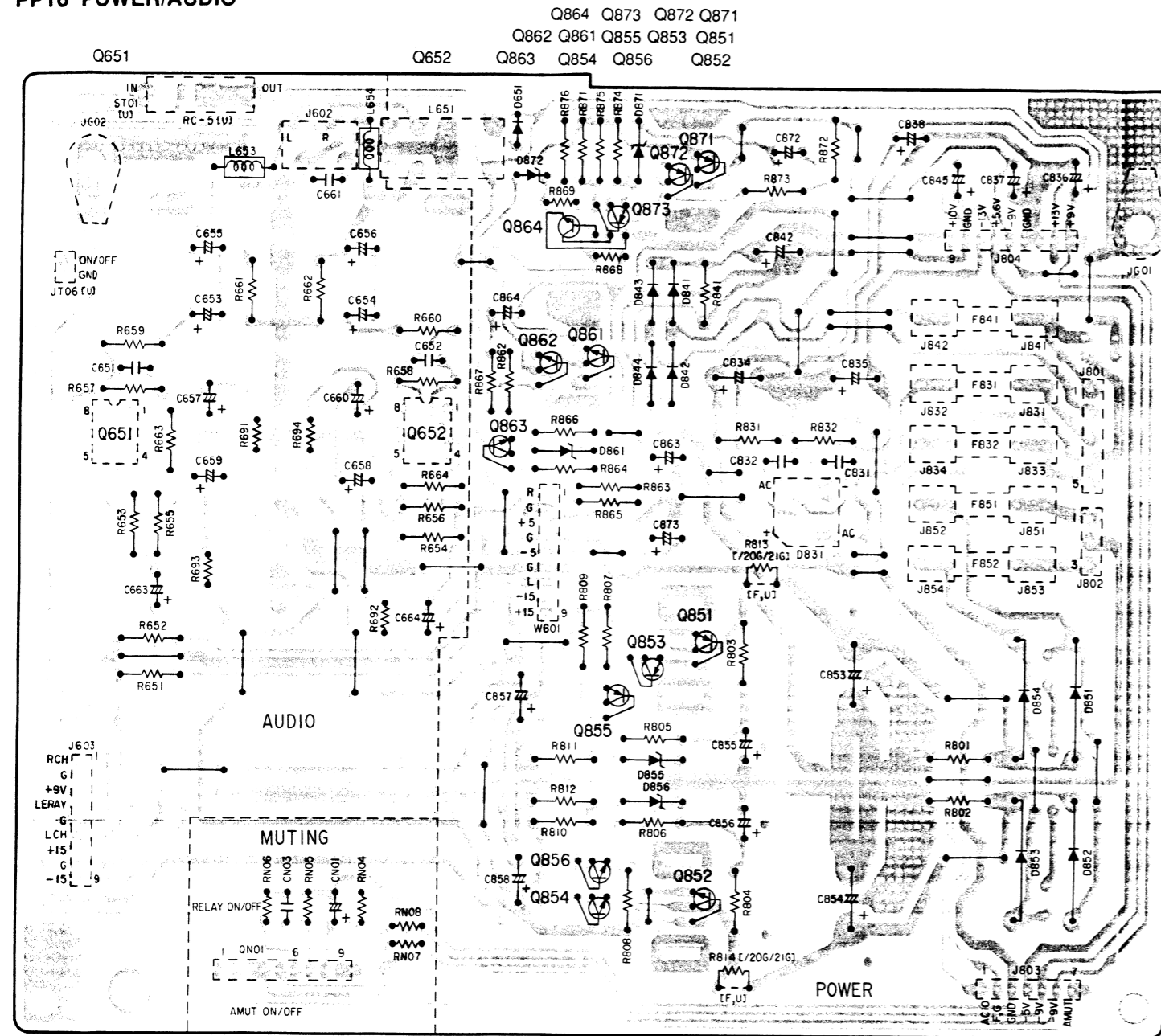

PS26 POWER SW

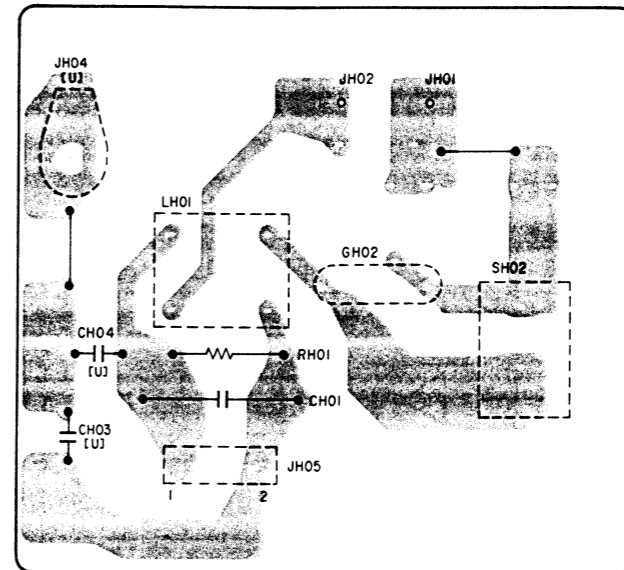

PP26 REGULATOR

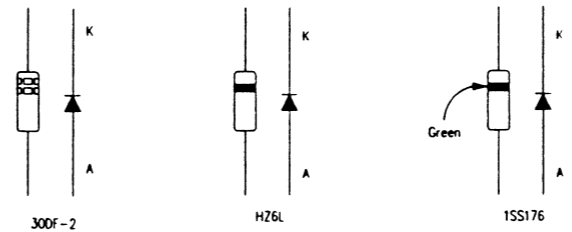
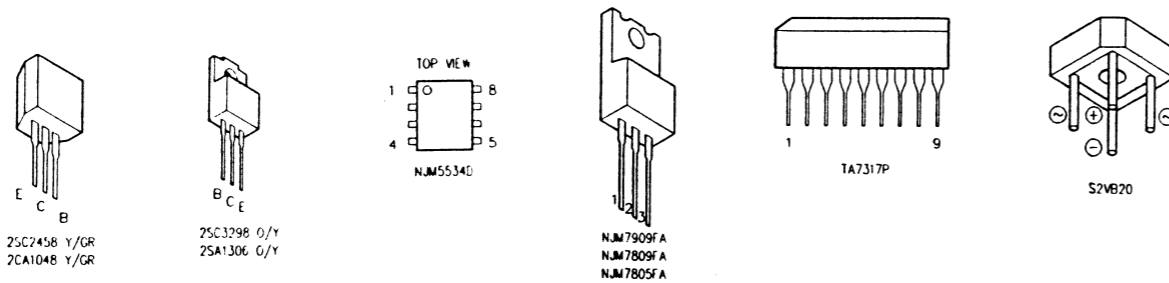
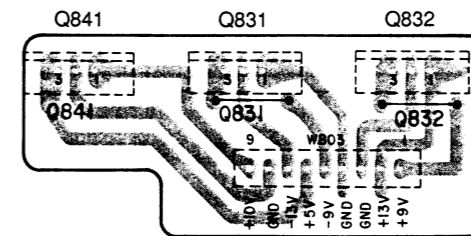

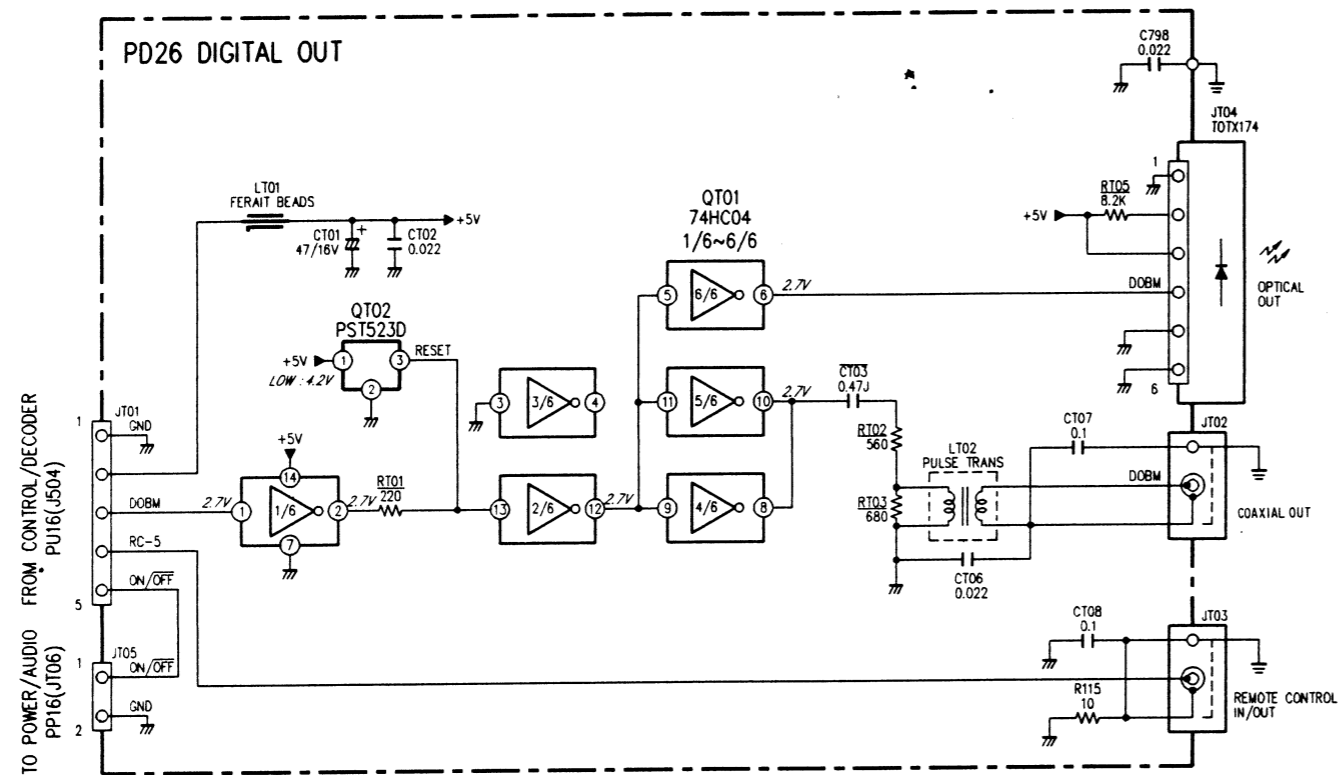

PD26 DIGITAL OUT

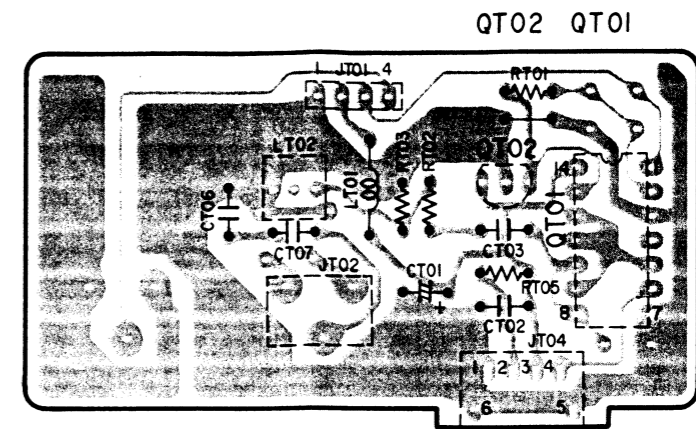

PY16 KEY-SENS/DISPLAY

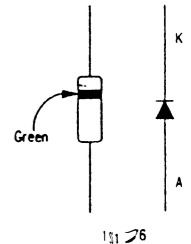
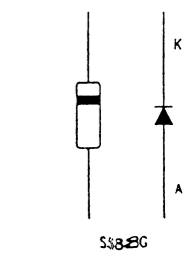
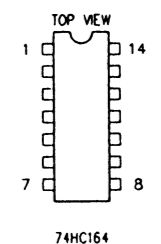
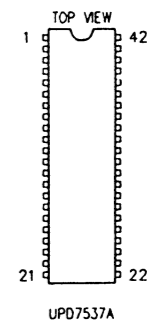
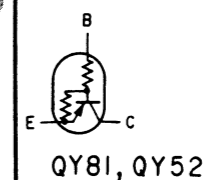
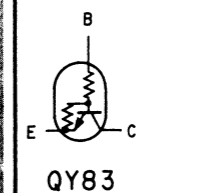
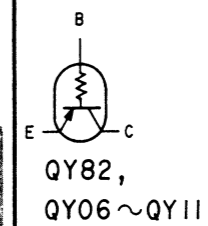
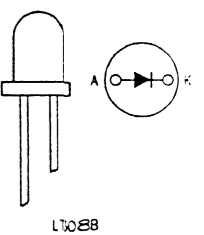
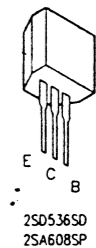
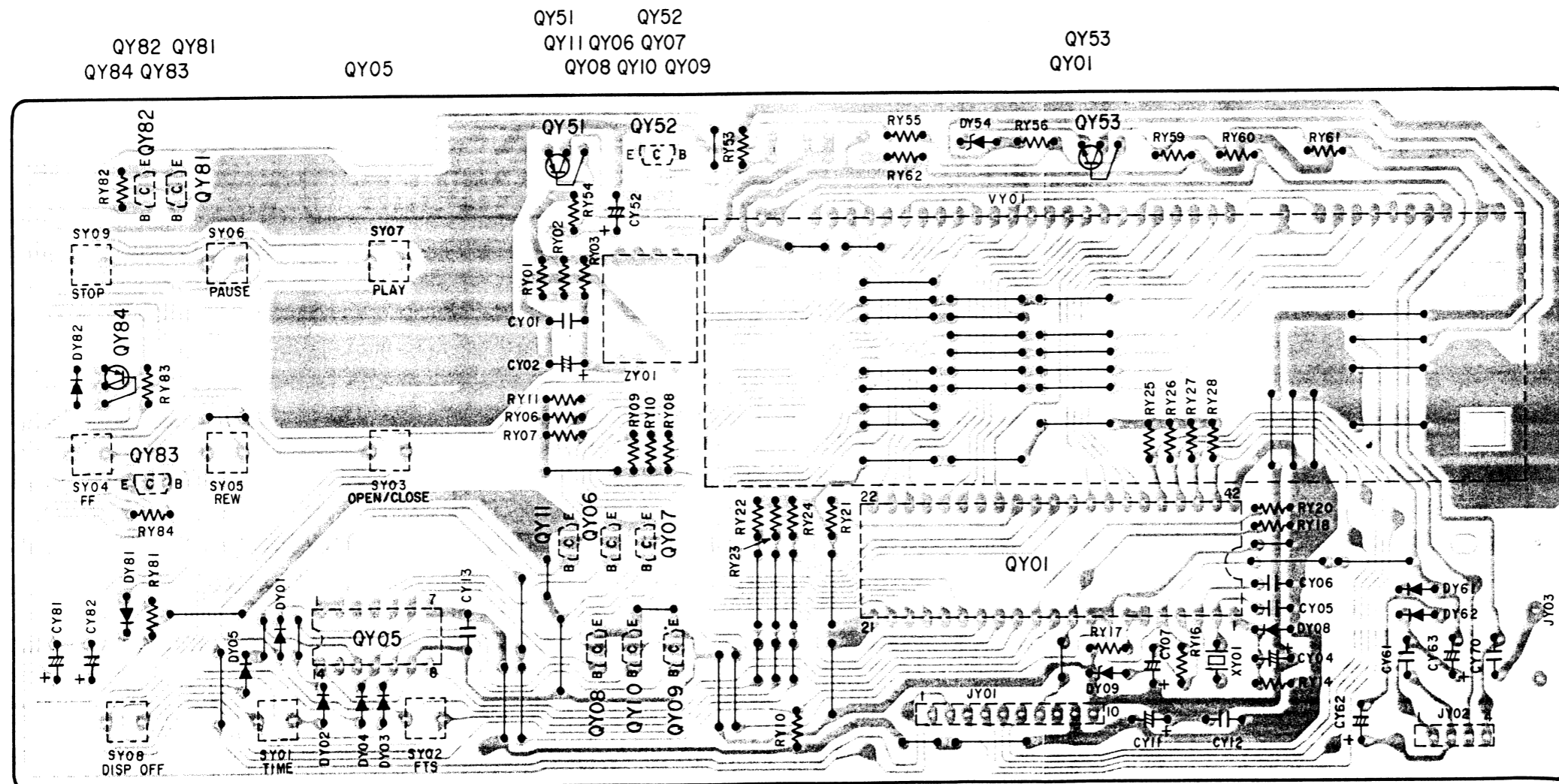

PY16 KEY-SENS/
DISPLAY

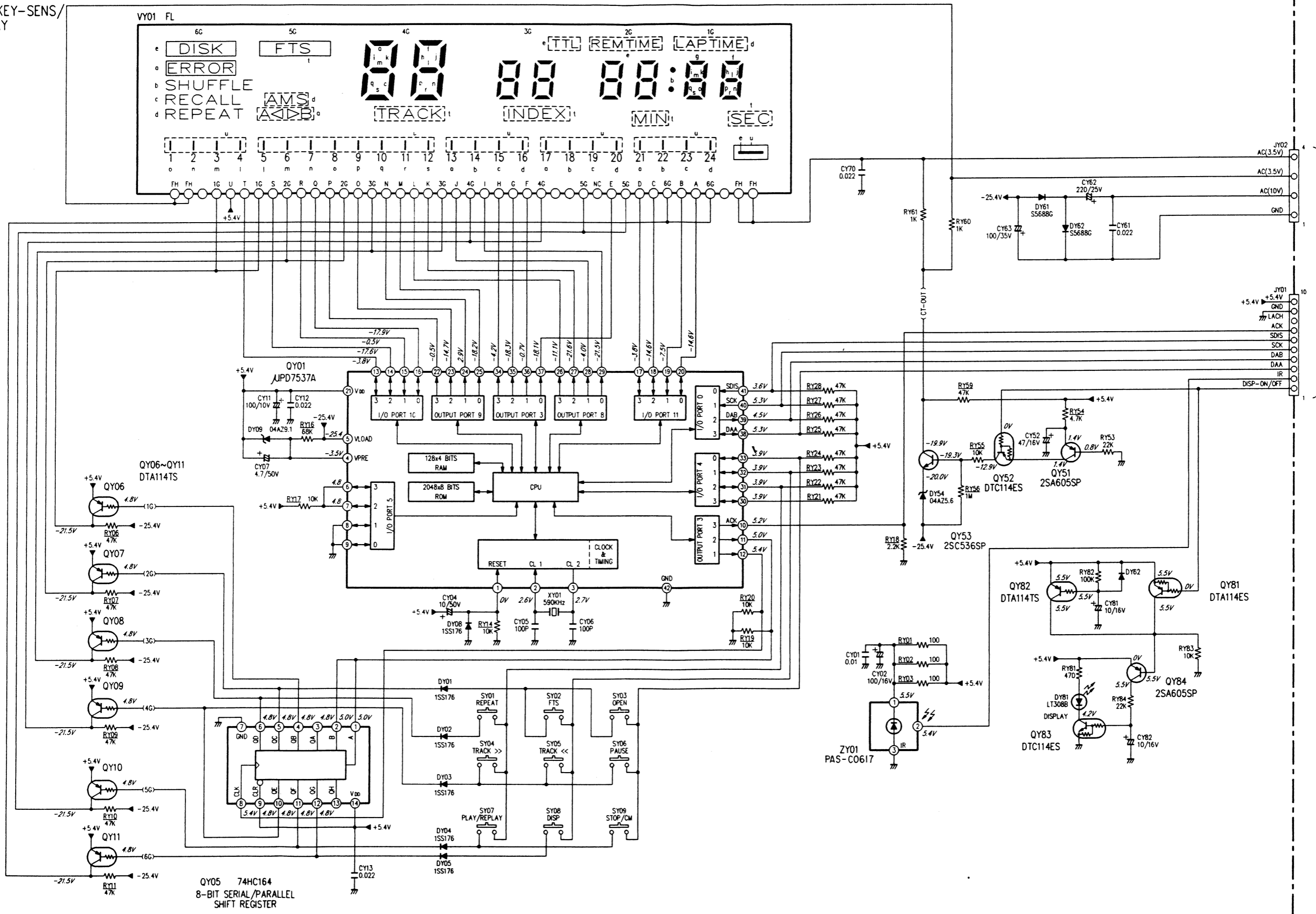

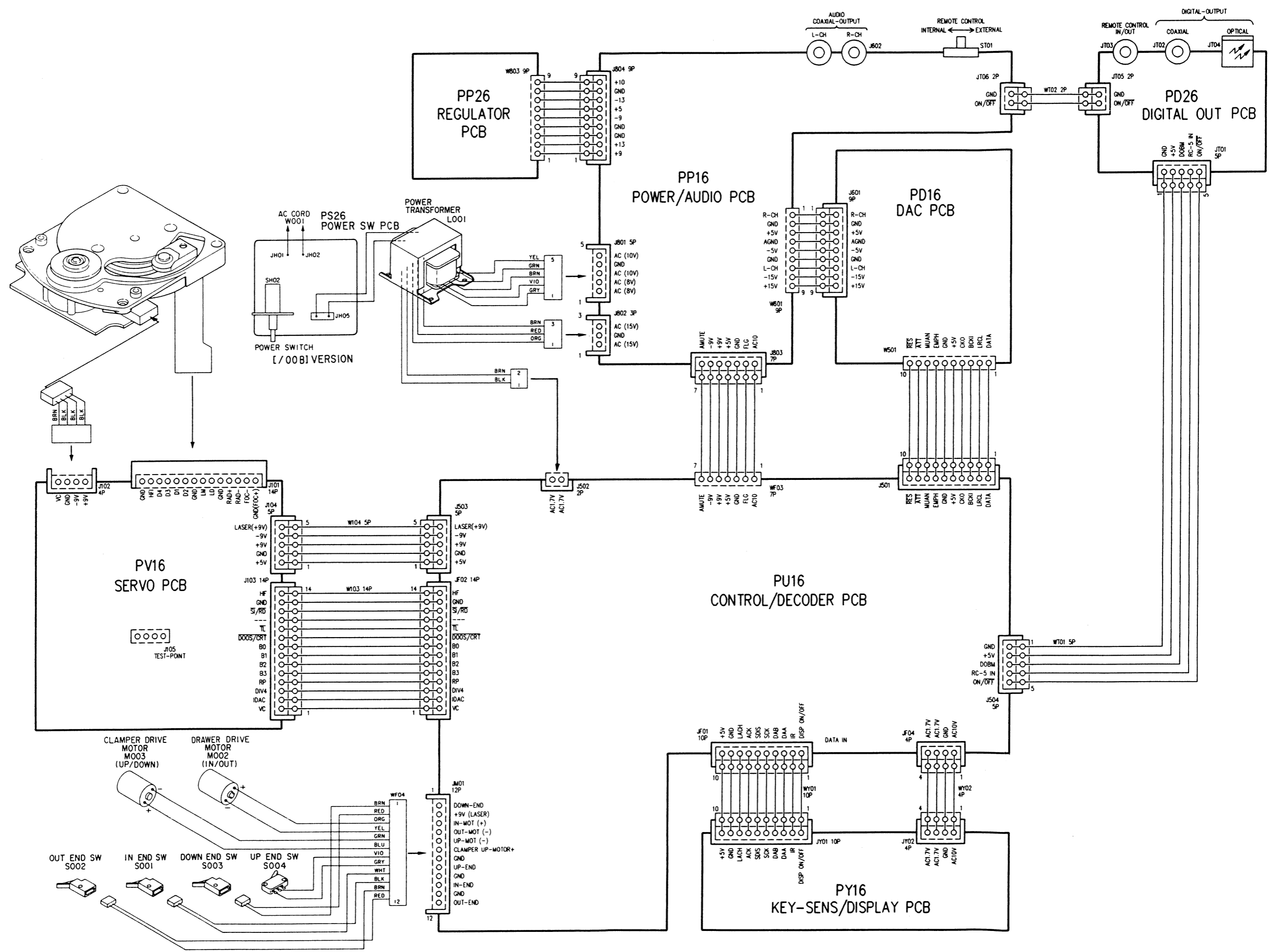

6 EXPLODED VIEW AND MECHANICAL PARTS LIST

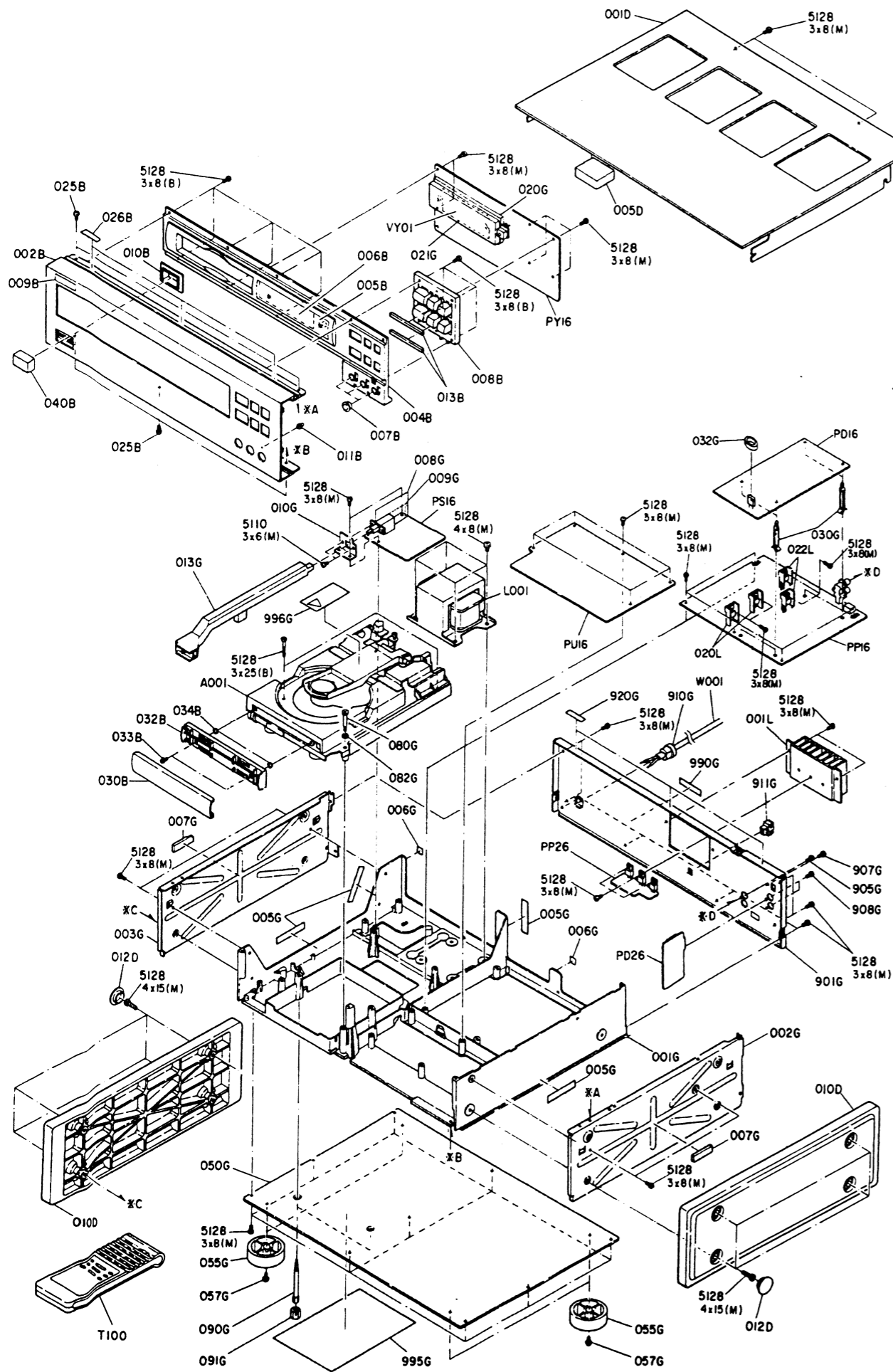

REF. DESIG.	PART NO.	DESCRIPTION
002B	4822 444 40652	FRONT PANEL
004B	4822 454 30482	ESCUTCHEON
005B	4822 450 62029	WINDOW
006B	4822 459 40729	FL-MASK (BLUE)
007B	4822 410 62505	BUTTON, FTS/REPEAT/D-OFF
008B	4822 410 62506	BUTTON
009B	4822 459 10943	BADGE
010B	4822 532 70319	BUSHING, POWER SW
011B	4822 381 11393	LENS, DISPLAY OFF
025B	4822 502 13636	PH.TAP.SCREW
030B	4822 454 30483	ESCUTCHEON
032B	4822 532 40218	RETAINER
033B	4822 502 13927	F.WASHER SCREW
040B	4822 410 61556	BUTTON POWER
010D	4822 444 40651	SIDE PANEL
012D	4822 443 62664	CAP, SIDE PANEL
013G	4822 402 61411	LINK, POWER SW
020G	4822 256 92037	HOLDER FL
021G	4822 459 10942	STICKER
055G	4822 462 41947	LEG
057G	4822 502 12511	B.T.SCREW(W/W)
080G	4822 502 13925	SCREW
082G	4822 530 80667	WAVE WASHER
090G	4822 532 30508	SHAFT
091G	4822 462 71495	CAP
905G	4822 502 13636	PH.TAP.SCREW
907G	4822 502 13636	PH.TAP.SCREW
908G	4822 502 13636	PH.TAP.SCREW
910G	4822 325 50202	BUSHING, AC CORD
L001	4822 146 21721	POWER TRANSFORMER [/00B]
VY01	4822 130 90441	DISPLAY UNIT
W001	4822 321 10804	A.C.POWER CORD
W100	4822 321 61923	CONNECTIVE CORD (FOR SUB CHASSIS)
J082	4822 321 22611	CONNECTIVE CORD, RCA AUDIO
J083	4822 321 22862	CONNECTIVE CORD, RCA GOLD 75Ω DIGITAL
T100	4822 218 10507	IR COMANDER (RC-10CD)
001T	4822 736 21677	USER MANUAL

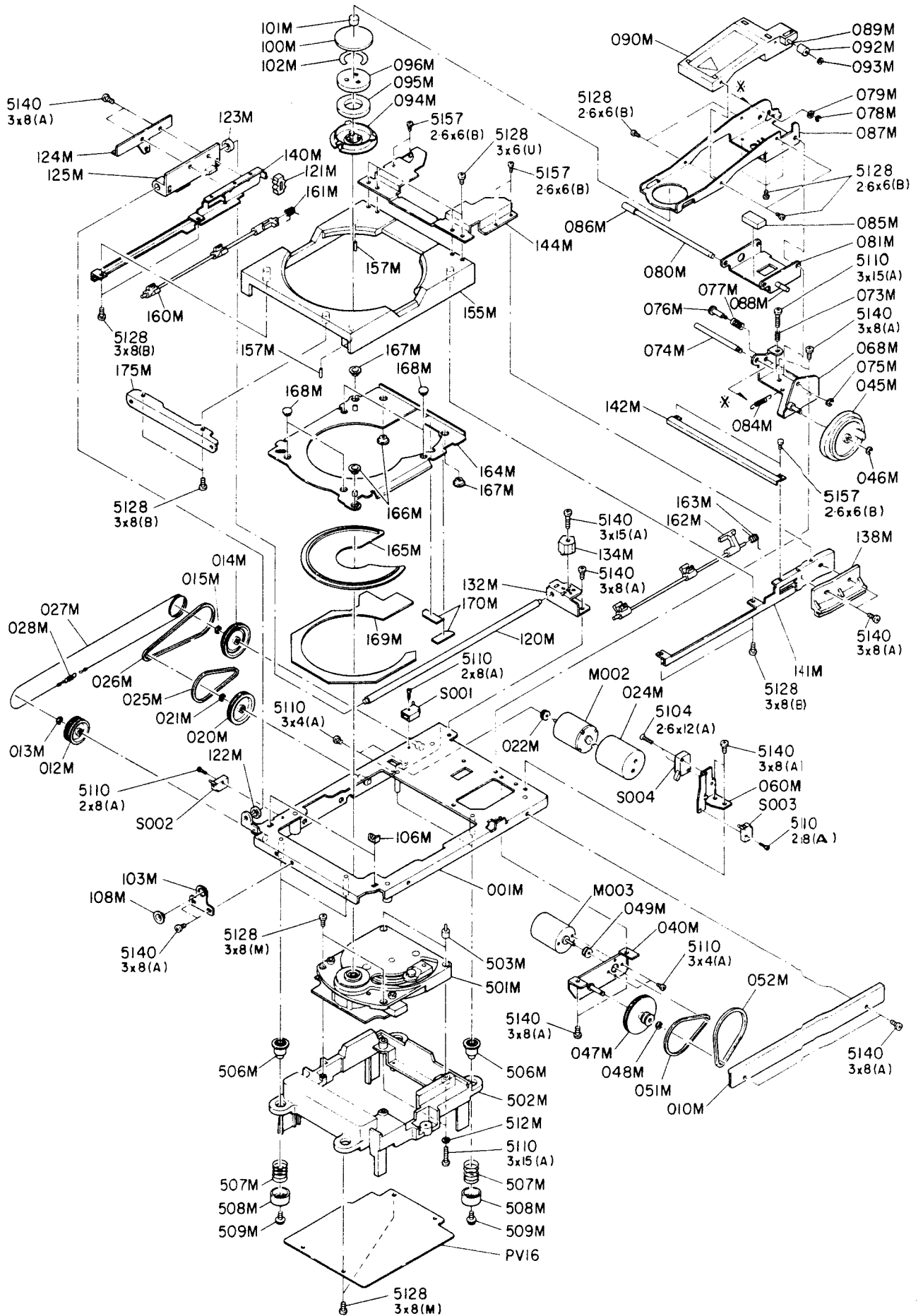

REF. DESIG.	PART NO.	DESCRIPTION
012M	4822 528 81163	PULLEY
013M	4822 530 70043	E RING
014M	4822 528 81387	PULLEY
015M	4822 530 70043	E RING
020M	4822 528 81238	PULLEY
021M	4822 530 70043	E RING
022M	4822 528 81166	PULLEY, MOTOR
025M	4822 358 30762	BELT, MOTOR
026M	4822 358 31065	BELT, TRAY DRIVE
028M	4822 492 33161	SPRING, TENSION
045M	4822 528 30392	CAM, CLAMPER
046M	4822 530 70043	E RING
047M	4822 528 81164	PULLEY, CLAMPER MIDDLE
048M	4822 530 70043	E RING
049M	4822 528 81166	PULLEY, MOTOR
051M	4822 358 30762	BELT, MOTOR
052M	4822 358 30763	BELT, CAM DRIVE
073M	4822 492 70628	SPRING, DOWN ADJUSTER
075M	4822 530 70043	E RING
077M	4822 492 70631	SPRING, L/R ADJUSTER
078M	4822 530 70122	E RING
079M	4822 532 52236	WASHER
084M	4822 492 70629	SPRING, CLAMPER PULL DOWN
088M	4822 528 90837	ROLLER
092M	4822 528 90836	ROLLER
093M	4822 532 51467	STOPPER
094M	4822 526 20174	CLAMPER
095M	4822 526 20173	MAGNET
096M	4822 528 90783	COVER
100M	4822 462 71811	BUFFER, CLAMPER
101M	4822 462 71809	BUFFER, CLAMPER TOP
102M	4822 466 61927	BUFFER, CLAMPER TOP
106M	4822 256 91867	HOLDER, TRAY FRONT SUPPORT
108M	4822 532 30509	BUSHING, FRONT GUIDE
125M	4822 256 91196	HOLDER, SLIDE BEARING
155M	4822 444 50574	CASE, TRAY
161M	4822 492 70633	SPRING, TRAY LIFT LEFT
163M	4822 492 70632	SPRING, TRAY LIFT RIGHT
164M	4822 444 50635	TRAY, U/D DISC
165M	4822 444 50677	TRAY, SINGLE
501M	4822 691 30276	MECHANISM CDM-4
502M	4822 444 60906	CASE, MECHA
506M	4822 532 21452	BUSHING, SUSPENSION RUBBER
507M	4822 492 70625	SPRING, SUSPENSION
508M	4822 530 70561	RETAINER
509M	4822 502 13926	F. WASHER SCREW
512M	4822 530 80349	SPRING WASHER
M002	4822 361 60467	D.C.MOTOR, TRAY DRIVE
M003	4822 361 60447	D.C.MOTOR, CLAMPER DRIVE
S001	4822 277 21132	SLIDE SWITCH, TRAY IN END
S002	4822 277 21132	SLIDE SWITCH, TRAY OUT END
S003	4822 277 21132	SLIDE SWITCH, CLAMPER DOWN END SENSOR
S004	4822 271 30712	MINI SWITCH, CLAMPER UP END SENSOR

7 TRAY MECHANISM LOADING PROCEDURES

Cautions when servicing

1. When mounting tray and tray case

(when replacing tray case because of damage etc.)

- a) When the tray has been positioned improperly with a deviated clearance to the front panel window, remove the tray lid, loosen screws \bar{A} and adjust by moving the tray frame within the range of the holes play.

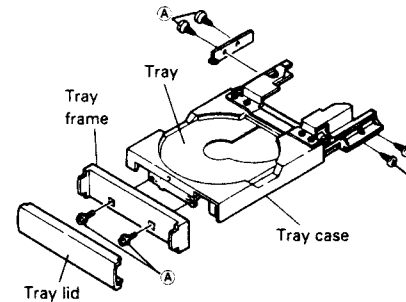

For the tray tilt adjustment, refer to the figure below.

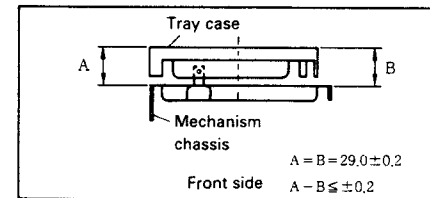

Adjust the tilt with screws \bar{A} .

- b) The operating power of the tray is set to 250 - 350gr (Power OFF).

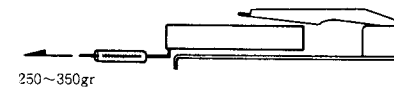

2. When the tray is disengaged to the lower side

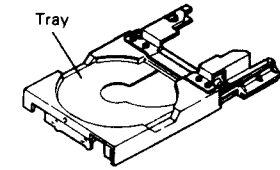

When the tray is pushed downward without the sub-chassis (CDM-4), it will be disengaged. So care will be necessary.

(Closing the tray without the sub-chassis also disengages the tray.)

Mount the tray referring to the figures below.

- a) Bring down the lever and put the tray on the protrusion of lever.

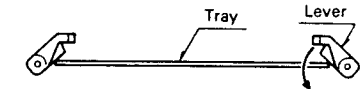

- b) While holding the tray, bring down the opposite lever and put the tray on the protrusion of the lever.



Note:

If both the levers are brought down at the same time, the tray cannot be raised. The levers should be brought down one by one.

If the tray is forced to move to the original position, the two pins injected into the tray case may be bent.

3. When replacing the sub-chassis (CDM-4)

- a) The height of the sub-chassis turn table is different one by one. Adjust each turn table height so that the magnet clasper does not touch the clasper metal strap as shown in the figure.
Standard (1.5 ± 0.3 mm)

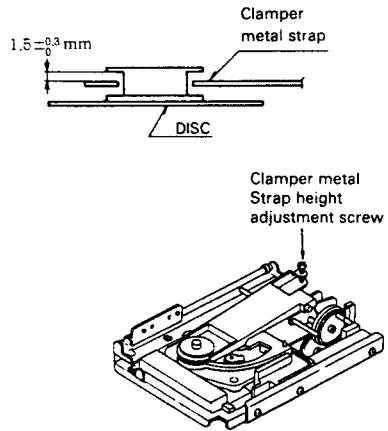

- b) After replacing the sub-chassis, readjust so that the magnet clasper does not touch the clasper metal strap at right and left sides. (The clasper metal strap should not be touched to other straps.)

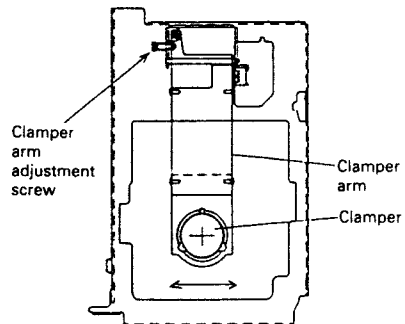

4. Others

- a) For the loading wire winding, refer to the figure below.

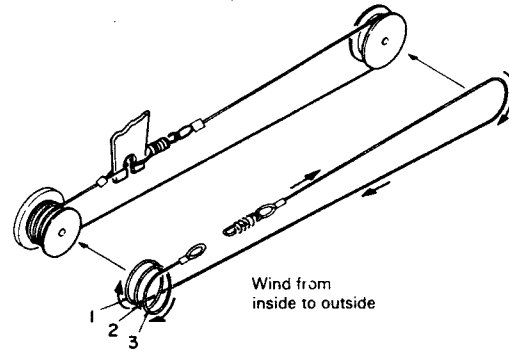

- b) When the magnet clasper (094M) is replaced, bent the narrowest tab and remove the clasper.

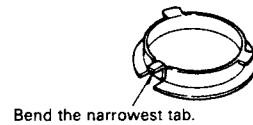

8 PRACTICAL HINTS

Test discs

It is important that the test discs be treated with great care. The disturbances on the discs (black spots, finger-prints, etc.) are exclusive and are unambiguously positioned. Damages may cause extra drop-outs etc., thus putting an end to the exclusivity of the intentional error on the disc. In that case it is not possible anymore to check for example the good functioning of the track detector.

Measurements on op-amps

In the electronic circuits, op-amps have frequently been used. The applications include amplifiers, filters, invertors and buffers.

In those cases where in one way or the other feedback has been applied, the voltage difference at the differential inputs converges to zero. This applies to both DC and AC signals. The cause can be traced to the properties of an ideal op-amp ($Z=\infty$, $G=\infty$, $ZO=0$). If one input of an op-amp is directly connected to ground, it will be virtually impossible to measure at the inverting and non-inverting inputs. In such cases only the output signal will be measurable.

That is why in most cases the AC voltage at the inputs will not be given. The DC voltages at the inputs are equal.

Stimulating with "0" and "1"

To find a location of failure circuit it is sometimes necessary to connect certain points to ground or to a power supply voltage. As a result certain circuits can be set to a desired state, thus saving the diagnosis time. Generally, if the points are outputs of op-amps, specified dummies are used to connect the output to the ground. As a result, the required check can be made with the circuit protected.

Measurements on microprocessors

Inputs and outputs of microprocessors should never be connected directly to the supply voltage. The inputs and outputs should only be brought to "0" or ground if this is stated explicitly.

Measurements with an oscilloscope

During measurements with an oscilloscope it is recommended to use a 1:10 test probe, since a 1:10 probe has a considerably smaller input capacitance than a 1:1 probe.

Selection of the ground potential

It is very important to select a ground point that is as close as possible to the test point.

Conditions for injection

- Injection of levels or signals from an external source should **never** take place if the relevant circuit has no supply voltage.
- The injected levels or signals should **never** be greater than the supply voltage of the relevant circuit.

Indication of the test points

In the drawing of the diagrams and PCBs the test points are indicated by a number (e.g. ②) to which the measuring method refers. In the following measuring method the symbol \diamond has been omitted for the test points indicated.

GENERAL CHECK POINTS

In the detailed measuring method below, a number of general conditions, required for a properly functioning set, will not be mentioned. Before the detailed measuring method is started, these general points should be checked:

- Ensure that the disc and objective are clean (remove dust, fingerprints, etc.) and use undamaged discs.
- Check that all supply voltages are present and that they have the correct values.

Initiation of the service programme of the μP

For the initiation of the service programme of the μP , see initiating the service programme.

SERVICING THE CDM UNIT

If the CDM is malfunction, replace whole, CDM unit.

9 INITIATING THE SERVICE PROGRAMME

The player can be brought in service position "0" to "3" whether the disc is put on the turntable or not. For the service position "2", the disc should be put on the turntable.

Service position "0"

- Press "STOP", "PLAY" and "FTS" simultaneously while switching on the mains voltage.
- The display shows:
 - The TRACK and INDEX field: Cd 10
 - The MINUTES and SECONDS field: 00 0
- Fast CDM check:
 - With SEARCH keys "◀◀" and "▶▶" (Remote Control only) or with jog dial, check that the radial arm moves most outward and inward. (Service position "0" to "3")
 - Laser control in.
 - Check that the focus unit jumps over the tracks.

ATTENTION:

After the player is brought in service position "0" the laser remains driven until service position "3". Therefore, avoid direct exposure to the beam in service positions "0", "1" and "2".

Service position "1"

- Bring the player in service position "0". Press SKIP key "▶▶".
- The display shows:
 - The MINUTES and SECONDS field: 00 1
- Functions:
 - Laser control in.
 - Focus start procedure is repeated unlimitedly. (If not, check SI/RD signal.)
 - With SKIP key "▶▶", one can go back to service position "0".

Service position "2"

- Without a disc on the turntable:
 - Bring the player in service position "1" with the power turned off and the disc put on the turntable.
- With a disc on the turntable:
 - With SEARCH key "◀◀", move radial arm most inward.
- Bring the player in service position "1".
- Press SKIP key "▶▶".
- The display shows:
 - The MINUTES and SECONDS field: 00 2
- Functions:
 - Laser control in.
 - Focus control in.
 - Turntable motor control in.
 - Decoder IC generates MC signal.
 - With SKIP key "◀◀", one can go back to service position "1".

ATTENTION:

When the radial arm is most outward with the disc on the turntable, the turntable (spindle motor) may turn reversely at high speed. In this case, with skip key bring the player in service position "1" or "3" from "2" immediately.

- Bring the player in service position "2". Press SKIP key "▶▶".
- The display shows:
 - The MINUTES and SECONDS field: 00 3
 - The set is the same condition as in STOP.
 - With SKIP keys "◀◀" and "▶▶", one can go to service positions "3" to "0" and vice versa.

Service position "E"

- Bring the player in service position "3".
- Without a disc on the turntable:
 - Press "PLAY" key, and the display shows the same as when the power is turned on normally.
 - Set a disc with "OPEN/CLOSE" key, and TOC data is displayed.
- With a disc on the turntable:
 - Press "PLAY" key, and TOC data is read and displayed.
- Press "PLAY" key again, and the mode is changed to PLAY.
- Functions: all keys have their original functions. (including remote controller)
- If an error is detected, the player will stop and give an error indication on the display. For a description of the error indication: See Error table.
- If the μ P observes a system error, a system error indication will appear on the display: Er 01 through Er 12.
- With any key pressed, system error mode (including error message) will be cleared. (With "PLAY" key, the PLAY mode will be brought again.)
- If the μ P observes an operation error, an operating error indication will be displayed for 1.5 seconds: Er 30 through Er 56.

The service programme can be abandoned again by turning the mains switch (POWER ON/OFF) off and on again (Hardware reset).

The error message number will be displayed only in service programme. (In normal mode, "ERROR" indication will just appear.)

SEARCH "▶▶" = Forward search key
SEARCH "◀◀" = Reverse search key
SKIP "▶▶" = TRACK NEXT key
SKIP "◀◀" = TRACK PREV key

ERROR TABLE

System errors

Indication	Cause	Check
Er 01	No RD	Si, So, RD, Photodiode signal processor
Er 02	No TL pulse at start-up	TL, HF, Photodiode signal processor, CD disc present
Er 03	No lead-in track found	CD disc, radial arm position, REdig, Radial error processor
Er 04	Too many TL pulses in PLAY	CD disc, HFD
Er 05	TL pulse > 50 msec. in PLAY	CD disc, HF in, photodiodes
Er 06	No TL pulse within 0.5 sec. during track jumping	RE-lag circuit
Er 07	Subcoding error during PLAY	HF
Er 08	TOC error	CD disc, turntable motor control, radial arm position
Er 09	EEROM set error	Replace EEROM
Er 10	Search error; selected point on disc cannot be reached	CD disc
Er 11	ROM error	Replace ROM
Er 12	RAM in μ P MC68HC11 defective	Replace μ P MC68HC11

Operating errors

- Er 30 "▶▶" key operated during the last track, with Repeat turned off.
- Er 31 "◀◀" key operated during the first track, with Repeat turned off.
- Er 32 Index selected before a track has been selected.
- Er 34 The programme memory is full.
- Er 35 The programme track is not present on this CD disc.
- Er 36 Selected time in seconds greater than 59.
- Er 38 Wrong time programmed.
- Er 39 The selected track is not present on this CD disc.
- Er 40 The selected track does not exist.
- Er 41 FTS data storage error: memory full.
- Er 42 FTS data storage error: no programme presented.
- Er 43 FTS data storage error: no more disc number.
- Er 44 FTS playback error: no FTS programme in the memory.
- Er 45 FTS selection error: "▶▶" key actuated while FTS points towards end of the number of tracks.
- Er 46 FTS selection error: "◀◀" key actuated while the FTS points to the beginning of the number of tracks.
- Er 47 FTS selection error: "▶▶" or "◀◀" key actuated at the moment the μ P is storing data.
- Er 48 FTS selection error: "◀◀" key actuated while the CD disc has not yet been stored in the FTS memory; or TOC of the disc has not yet been read in.
- Er 49 FTS selection error: "▶▶" key actuated.

- Er 50 FTS clear error: "CANCEL" key actuated while data are being stored in the memory.
- Er 51 "CANCEL" key actuated, but clear function has not been carried out.
- Er 52 FTS data storage error: TOC of the CD disc, of which data should be saved, has not yet been read in.
- Er 53 FTS playback error: insufficient data of the TOC of the CD disc read in for processing in the FTS memory.
- Er 54 "A - B" key actuated while the player was not in PLAY mode.
- Er 55 "SEARCH" key actuated during Skip mode.
- Er 56 End of the "FAST FORWARD or FAST REVERSE" search motion.

10 MEASUREMENTS AND ADJUSTMENT FOR CDM4 (SUB CHASSIS)

Check of the laser supply

The laser circuit generates a laser beam with LO signal at pin 17 of Q101, and the monitor diode makes LM signal. These circuits constitute a feedback system and controls the laser output.

If, in that case, the laser (= complete CDM unit) is replaced, the new laser will also become defective.

However, it is impossible to check and repair a feedback system if a link is missing. For this reason the laser supply can be checked with the circuit below. The green LED replaces the laser, the voltage across the 18-Ohm resistor is fed back as monitor voltage, the 33-Ohm resistor and the switch serve to draw more current from the laser supply.

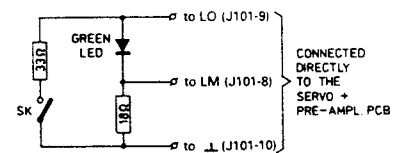

LED GREEN e.g. COY 94 IV 5322 130 32182

The above circuit is connected to connector J101 via an extension cable instead of flex print. The normal flex print is not suited for this purpose because of its high internal resistance.

Code no. extension cable 4622 322 40066

- The above flex print out of connector J101 on the servo + pre-amplifier PCB.
- Connect the circuit via the extension cable to connector J101.
- Select the play mode and SI/RD (pin 6 of Q101) will be "high".
- Measure the voltage LO (Laser Out) at test point 11.

Note:

SI/RD = 0, start initialization "high", is the play mode. At SI/RD : "low", in the STANDBY state, LO = 0 V ± 0.2 V.

SK open: 1.8 V < LO < 2.3 V
170 mV < LM < 220 mV
The green LED emits little light.

SK closed: 1.8 V < LO < 2.3 V
170 mV < LM < 220 mV
The green LED emits little light.

- During the change-over from SK closed to SK open, the LED will emit more light for a short moment.
- The control sees to it that the same amount of current flows through the LED when SK is open and when SK is closed.

Repair procedure

Since laser, monitor diode and photodiodes are very sensitive to static charges, care should be taken that during measurements and adjustments the aids and yourself have a potential that is equal to that of the CD mechanism.

Laser adjustment for CDM4

- Measure the resistance of R108 + R134 with an ohmmeter and adjust potentiometer R134 so that R134 + R108 have a combined value of 1 kΩ.
- Check the monitor diode connections. Measure at test point 13 and ground (⊥).
- Put test disc "5" on the turn table.
- Switch on the set and select the PLAY mode or a similar service position.
- Take a DC voltmeter and measure across R116. The voltage across this resistor should **stay smaller than 1260 mV**.
- Check if HF is present. If not, stop the measurement immediately and analyze the fault.
- If HF is present, play track no. 1 of test disc "5" and adjust R134 (2.2 k) so that the sum of HF across R114 (test points 1 and 2) becomes 50 mV ± 2 mV with a DC voltmeter.

Check, during the adjustment, that the voltage across R116 does not exceed 1260 mV.

- If the adjustment is not successful within the 1260 mV margin across R116, check the angle setting.

Adjustment of the focus off-set (FE-lag)

- **Coarse adjustment**
- A - Place potentiometer R136 approximately in mid-position.
 - Put test disc "5" on the turntable.
 - Bring the player in service position "2".
 - The focussing motor can now start focussing. Check that the disc is moving.
- B - Place with potentiometer R136 (Focus Offset) the focussing motor in optical horizontal position.
 - Hereafter the fine adjustment of the focus offset has to be carried out.
- **Fine adjustment**
- Bring the player in service position "2".
- Adjust potentiometer R106 (Focus Offset) for a voltage across R106 (test point 27) of 400 mV ± 40 mV.

Note:

Notice that CDM is in a horizontal position.

11 DETAILED MEASURING METHOD FOR THE SERVO + PRE-AMPLIFIER CIRCUIT

PHOTODIODE SIGNAL PROCESSOR IC (Q101)

- Check the SI/RD, LO, LM signals

SI/RD (pin 6; test point 24)
LO (pin 17; test point 11)
LM (pin 18; test point 13)

- With the SI/RD signal (= Start Initiation) the laser supply, among other things, is switched on. When the SI/RD signal is "high", the LO signal (= Laser Out) should be "high". Via the LM signal (= Laser Monitor) the power supply for the laser diode is controlled.

Position of Player	POWER ON	Service position "1"	PLAY
SI/RD signal	"low"	* "high"	"high"
LO signal	"low"	"high"	"high"

*) "low" pulse when focussing starts

- Check the FE signal

FE (pin 15; test point 19)

- The FE signal (= Focus Error) is used to drive the focussing unit.
- When the SI/RD signal goes "low" pulse, the focal point will be searched for.
- When the player is brought into service position "1", the objective will search for the focal point. At test point 19 the FE signal varies between +1.5 V and -1.5 V.
- When the player is brought into service position "2" (with disc on turntable), the FE signal ensures that the laser spot stays in focus. If an error signal is injected, the FE signal will correct.
- Inject successively a voltage of +5 V and -6 V (= +5B and -6B) via a 200 kΩ resistance to test point 25 and check the FE signal.

Signal injected : testpoint 25	+ 5V	- 6V
FE signal : test point 19	negative	positive

- Check the FE lag

FE lag (pin 16; test point 22)

- See adjustment of the focus off-set.

- Check the D1 to D4 signals

D1 (pin 23; test point 6)
D2 (pin 22; test point 4)
D3 (pin 24; test point 7)
D4 (pin 25; test point 8)

- The signals D1 to D4 are the error signals from the photodiode circuits.
- When in service position "2", the focusing unit should keep in track. When the disc is moving, there should be a changing signal on test points 4, 6, 7 and 8.

- Check the photodiodes

Connected the circuit below to an alternating voltage of 17.5 V.

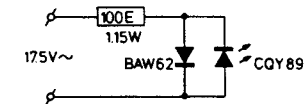

100 Ω, 1.15W - 4822 116 51098
BAW 62 - 4922 130 30613
CQY 89 - 4822 130 31332

Switch on the supply voltage (17.5 V) and bring the player in the stand-by mode or in service position "0". In this measurement, infrared diode CQY89 replaces the function of the laser diode.

When this diode is held above the objective unit, the infrared light falls on the 4 photodiodes. When the 4 photodiodes are functioning, the following voltage form will be visible on test point 4, 6, 7 and 8 on the servo + pre-amplifier PCB. (The amplitude depends on the distance between the IR diode and the objective).

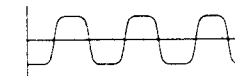

Position of the oscilloscope: 100 ns/div.

• **Check the HF-in signal**

HF-in (pin 26; test point 3)

- The HF-in signal (= High Frequency in) is the information signal from the 4 photodiodes.

• **Check the HF amplifier in Q101**

- Take the flexible PCB out of connector J101.
- Switch on the supply voltage.
- Inject a signal V-in of about 10 mVpp, 50 kHz, via the RC network, between connector pin J101-2 and connector pin J101-7 according to the diagram below.
- The output voltage (Vout) between connector pins J103-13 and J103-14 should be about 1 Vpp.

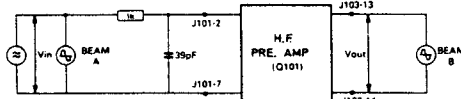

• **Check the HF-out signal**

HF-out (pin 3; test point 21)

- The HF-out signal (= High-Frequency out) is the amplified information signal for the decoder circuit. During playback of test disc "5" (4822 397 30098), a so-called "eye pattern" should be present on test point 21 (see figure below).
 - The HF signal should be present and stable in the PLAY mode and in service position "E" after the lead-in track has been read.
- In service position "2" and during the reading of the lead-in track, the HF signal is present, but is not stable.

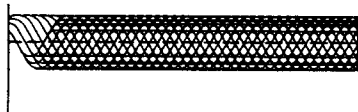

Position of the oscilloscope: 0.5 μs/div.
Amplitude: about 1.5 Vpp

• **Check the DET, TL signals**

**DET (pin 4)
TL (pin 11; test point 9)**

- The DET signal (= Detector) gives information on the level of the HF signal to the high-frequency Level/Drop-out detector of Q101.
- The TL signal (=Track Lost) will then go "low" in order to tell the servo μP that the tracking signals are unreliable.

Method:

(Can only be used in a playing set).

- Put test disc "5A" (4822 397 30098) on the turntable.
- When track number 10 or 15 is played, the drop-out pulses will be present on the DET signal (pin 4). (Position of oscilloscope: 2 ms/div.)

When the disc is slowly braked by hand, TL pulse will be visible at test point 9. ("low" pulse or "low")

• **Check the RE1, RE2 signals**

**RE1 (pin 21; test point 14)
RE2 (pin 20; test point 16)**

- Signals RE1 and RE2 (= Radial Error) are the control signals for the arm during tracking.
- In service position "2", the following signals should be visible at test point 14 and 16.

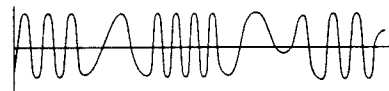

Position of the oscilloscope: 2 ms/div.
The frequency strongly depends on the eccentricity of the disc.

• **Check the DODS/CRI signals**

DODS/CRI (pin 12; test point 18)

The DODS signal (=Drop Out Detector Suppression) avoids that Drop-Out signals influence the arm control during tracking jumping. ("low" in jumping)

Position of Player	Power ON	Service position "E"	Play	Search pause
DODS/CRI	"low"	"high"	"high"	"low" pulse

• **Check the SC (= Start Capacity) signal**

SC (pin 5; test point 26)

Position of player	SC (pin 5)
POWER ON	4V
PLAY	+ 5V
Service position "1"	* 4V

* Repeats for focusing.

• **Check the FE lag signal**

FE lag (pin 16, test point 22)

- In service position "2", "E" and in the PLAY mode, a voltage of about 400 mV (Focus Offset voltage) is present at this point.

See adjustment of the focus off-set.

RADIAL ERROR PROCESSOR IC Q103

Check the signals coming from the servo μP and from photodiode signal processor Q101.

• **Check the RE-dig signal**

RE-dig (RP) (pin 7; test point 31)

- With the RE dig signal (= Radial Error digital = Radial Polarity), the movement of the arm is controlled/corrected in case of track jumping and bumping against the player.
- In service position "E" or in the PLAY mode a square wave should be present at test point 31. Because of frequency variations this square wave is hard to trigger.
- In the positions "◀◀" and "▶▶" SKIP keys, the frequency of the square wave decreases.

• **Check the RE signal**

RE (pin 15; test point 36)

- With the RE signal (= Radial Error) the light spot is kept on the track.
- When an error signal is injected, the RE signal will correct.
- Bring the player in service position "E".
- Inject successively a voltage of +5 V and -6 V (= +5B and -6B), via a 120 kΩ resistance, to ICQ106 and check the RE signal.

Signal injected testpoint 38	+ 5V	- 6V
RE signal: test point 36	negative	positive

• **Check the RE-lag signal**

RE lag (pin 18; test point 42)

- Capacitor C121 in the RE-lag circuit has a memory function.
- It memorizes the degree of inclination of the disc.
- When a jump is made to a certain track on the disc, the memory should be cleared.
- This takes place by the decoder μP (QF02, B0 to B3) via ICQ103.
- During track jumping (SEARCH), slow pulses should be visible at test point 42 (position of the oscilloscope 0.1 ms/div.).

• **Check the RE1, RE2 signals**

**RE1 (pin 21; test point 14)
RE2 (pin 20; test point 16)**

- See measuring method of RE1 and RE2.

• **Check the B0 to B3 signals**

**B0 (pin 11; test point 37)
B1 (pin 10; test point 38)
B2 (pin 9; test point 41)
B3 (pin 8; test point 39)**

- With the B0 to B3 signals; the radial control is switched on and the level on the DAC output is controlled.
- Depending on the SEARCH directions "◀◀", "▶▶" and total operation modes of 4, B0 to B3 signals become as shown below.

	STOP	PLAY	Service position "0", "1", "2"	"◀◀" search	"▶▶" search
B0	"low"	"high"	"low"	"low"	"low"
B1	"high"	"high"	"high"	"high"	"high"
B2	"high"	"high"	"high"	"high"	"low"
B3	"high"	"low"	"high"	"high"	"high"

• **Check the VC signal**

VC (connector point J102-1; test point 83)

- Place a disc on the turntable. The voltage at connector point J102-1 will be about Vc: -1.7 V < Vc < 0 V during playback.

12 DETAILED MEASURING METHOD FOR THE DECODER CIRCUIT

DECODER IC (Q501)

- Check the MC signal

MC (pin 24; test point 74)

The MC signal is used to control the speed of the turntable (spindle motor).

- In stand-by mode, the MC signal (Motor Control) corresponds to the figure below.

Note:

The repetition time of the MC signal is 11.3 μ sec.

- Place a disc on the turntable.
- In position PLAY or service position "E", the MC signal corresponds to the figure below.

Note:

During start-up the duty cycle is 98 %, then the duty cycle of the signal becomes about 50 %.

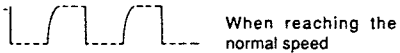
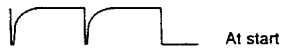

- Check the HF signal

HF (eye pattern; test point 61)

- Place a disc on the turntable.
- When reading of the lead-in track is completed in the PLAY mode or in service position "E", normal HF signal becomes the eye pattern as shown below.

Note:

In service position "2" or during reading of the lead-in track the HF signal is not stable.

Amplitude = 1.5 Vpp (eye pattern)



- Check the Xin signal

Xin (pin 26; test point 77)

- The Xin frequency is 11.2896 MHz.
- If this frequency deviates, check XIN (pin 9) on ADOC IC (Q504). This frequency should be 11.2896 MHz.

- Check the timing signals meant for Filter IC (Q502)

WSAB (pin 4; test point 78)

CLAB (pin 3; test point 79)

DAAB (pin 2; test point 81)

- Place a disc on the turntable.
- Service position "E" or PLAY mode.
- Trigger the oscilloscope with the WSAB signal.
- Check the interrelation between the WSAB signal and the CLAB signal.
- The DAAB signal being sent to the Delay IC (Q565) can be observed by triggering the oscilloscope with the WSAB signal. (The data waveform is not stable.)

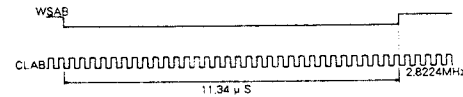

- Check the EFAB signal

EFAB (pin 1; test point 66)

- Place test disc "5A" on the turntable.
- During playback, EFAB pulses should be present at test point 66 for soft braking of the disc and during fast search (F. Forward, F. Reverse).



- Check the Q-channel signals

QRA (pin 38; test point 62)

QCL (pin 40; test point 63)

QDA (pin 37; test point 64)

- Place a disc on the turntable.
- Service position "E" or PLAY mode.
- Trigger the oscilloscope with the QRA signal (Q-channel Request Acknowledge).
- Check the interrelations of QRA and QCL (Q-channel clock) signals between the master μ P (QF01).
- If they are normal, check the QDA signal (Q-channel Data).

Note:

The QRA request is initiated by QF01 (QRA "high"). Then Decoder-A answers this request (QRA goes "low"). With the next leading clock pulse (QCL) the QRA signal is rendered "high" again by the QF01. As soon as the Decoder-A has taken in enough information via QDA, QRA will go "low" again. That is why the QRA times vary each time.

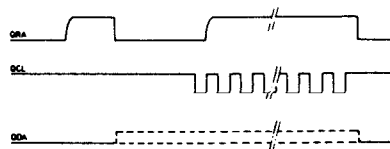

- Check the SWAB/SSM signal

SWAB/SSM (pin 42; test point 65)

- Motor start pulse when test point 65 is "high" for ≤ 0.2 sec.
- Motor stop pulse when test point 65 is "low" for ≤ 0.2 sec.

Note:

After the motor start pulse goes "high", SWAB information (Subcoding Word clock) will become visible at this point. The period time of that signal is 136 μ sec (7.35 kHz).

- Check the subcode clock signals

SWAB/SSM (pin 42, test point 65)

SCAB (pin 44, test point 70)

SDAB (pin 43, test point 68)

- Place a disc on the turntable.
- Service position "E" or PLAY mode.
- Trigger the oscilloscope with the SWAB signal at test point 65.
- Check the SCAB signal (Subcode Clock).
- Check the SDAB signal (Subcode Data).
- Check that the signals above are sent to ADOC (DIGITAL OUT) IC (Q504) without interruption. However, they go "low" at PAUSE/STOP mode.

Note:

While the burst of 10 clock pulses appear on SCAB, the Q-channel information is transferred on SDAB. Hereafter the P-bit indication follows.

The P-bit is "high" between two bursts of 10 clock pulses in case of pause indication and "low" in case of music indication.

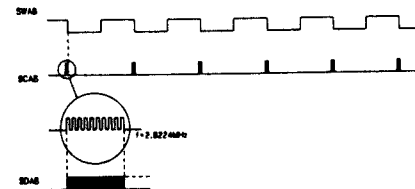

- Check the DODS/CRI signal

DODS/CRI (pin 36; test point 18)

The CRI signal (Counter Reset) goes "low" in track jumping and the signal makes the internal counter to free-running status. (See PHOTODIODE SIGNAL PROCESSOR IC (Q101). Check the DODS/CRI signal section.)

- Check the DEEM signal

DEEM (pin 41; test point 69)

- Place test disc "5" on the turntable.
- During playback of track number 15, the DEEM signal should be "high". (DE-EMPHASIS ON)

ADOC IC (Q504)

This IC (ADOC: Audio Digital Output Circuit) generates the DOBM signal out of the I²S data and subcode data.

- Check the WSAB, DOBM signals

WSAB (pin 1; test point 78)

DOBM (pin 13; test point 85)

- Place a disc on the turntable.
- STOP mode or PLAY mode.
- Trigger the oscilloscope with the WSAB signal.
- Check the DOBM signal.

Note:

As shown below, the DOBM signal makes a pattern when an audio signal enters, but the data section of the DOBM signal is not specified when the audio signal does not enter.

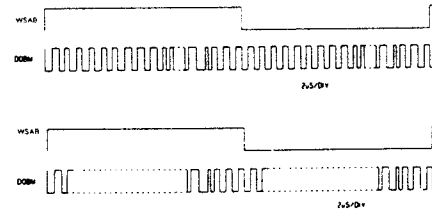

CHECK THE ATSB, MUSB SIGNALS

ATSB (QF02, pin 20; test point 57)

MUSB (QF02, pin 21; test point 58)

- The ATSB signal goes "low" during searching with attenuation (-12 dB) in.
- The MUSB signal goes "low" during PAUSE, SKIP, and track jumping with mute in.

FILTER IC (Q563)

- Check the signals between Decoder IC and Filter IC

WSAB (W501-pin 2; test point 78)

CLAB (W501-pin 3; test point 79)

DAAB (W501-pin 1; test point 81)

LRCI/WSAB (pin 28; test point 78)

BCKI/CLAB (pin 2; test point 88)

DIN (pin 1; test point 89)

The DAAB, CLAB, WSAB signals are output from Decoder IC (Q501) in I²S format. A format conversion is required for inputting these data into the Filter IC (Q563). For this purpose, the DAAB signal is delayed by 16 bits with the CLAB clock in the Shift Register IC (Q565, Q566). As a result, the delayed DAAB signal from pin 13 of IC566 is input to Filter IC (Q563). (See the timing chart.)

REF. DESIG.	PART NO.	DESCRIPTION
RD13 ?	4822 111 91355	13KΩ ±1% 1/10W CHIP
RD16 RD17 ?	4822 111 90967	4.7Ω ±5% 1/4W FUSE
RD20 RD21 ?	4822 111 91355	13KΩ ±1% 1/10W CHIP
RD24		
RD25	4822 116 83255	3.3KΩ ±1% 1/10W CHIP
RD26	4822 116 83255	3.3KΩ ±1% 1/10W CHIP
RD27	4822 116 83352	560Ω ±5% 1/10W CHIP
RD28	4822 116 83352	560Ω ±5% 1/10W CHIP
RD29	4822 111 91369	1.5KΩ ±5% 1/10W CHIP
RD30	4822 111 91369	1.5KΩ ±5% 1/10W CHIP
RD31	4822 116 83255	3.3KΩ ±5% 1/10W CHIP
RD32	4822 116 83255	3.3KΩ ±5% 1/10W CHIP
RD33 ?	4822 111 90967	4.7Ω ±5% 1/4W FUSE
RD38		
R561	4822 111 90967	4.7Ω ±5% 1/4W FUSE
R562	4822 111 90897	1MΩ ±5% 1/10W CHIP
R563	4822 111 90894	1KΩ ±5% 1/10W CHIP
R564	4822 111 90897	1MΩ ±5% 1/10W CHIP
R565	4822 111 90967	4.7Ω ±5% 1/4W FUSE
R566	4822 111 90893	100Ω ±5% 1/10W CHIP
R569	4822 111 90897	1MΩ ±5% 1/10W CHIP
R572	4822 111 90893	100Ω ±5% 1/10W CHIP
R573	4822 111 90893	100Ω ±5% 1/10W CHIP
R575	4822 111 90892	0Ω ±5% 1/10W CHIP
R590	4822 111 90967	4.7Ω ±5% 1/4W FUSE
R601	4822 111 90883	10KΩ ±1% 1/10W CHIP
R602	4822 111 90883	10KΩ ±1% 1/10W CHIP
R603 ?	4822 116 83255	3.3KΩ ±1% 1/10W CHIP
R606		
R607	4822 111 90883	10KΩ ±1% 1/10W CHIP
R608	4822 111 90883	10KΩ ±1% 1/10W CHIP
R609 ?	4822 116 83255	3.3KΩ ±1% 1/10W CHIP
R612		
R613 ?	4822 111 90883	10KΩ ±1% 1/10W CHIP
R620 R621 ?	4822 116 83232	8.2KΩ ±1% 1/10W CHIP
R624 R625 ?	4822 117 10183	2.61KΩ ±1% 1/10W CHIP
R628 R629 ?	4822 111 90731	47Ω ±2% 1/4W FUSE
R636		
R639	4822 111 90892	0Ω ±5% 1/10W CHIP
R640	4822 111 90892	0Ω ±5% 1/10W CHIP
QD01	4822 209 31013	PD16-SEMICONDUCTORS IC DAC7 TDA1547 1BIT DAC
QD02	4822 209 31013	IC DAC7 TDA1547 1BIT DAC
Q561	4822 209 30438	IC BS DAC SMA7350
Q563	4822 209 31011	IC DIGITAL FIL SM5803APT
Q564	4822 209 61494	IC 74HC74F
Q565	4822 209 62764	IC 74HC164F
Q566	4822 209 62764	IC 74HC164F
Q567	5322 209 73187	IC 74HC04F
Q601	4822 209 83359	IC NJM5532M
Q602	4822 209 83359	IC NJM5532M

REF. DESIG.	PART NO.	DESCRIPTION
Q603 ?	4822 209 30062	IC NJM5534M FLAT
Q606		
L601	4822 157 53873	PD16-MISCELLANEOUS CHOKO COIL 100μH
L602	4822 157 53873	CHOKO COIL 100μH
X561	4822 242 72395	CRYSTAL, 11 2896MHZ
X562	4822 242 72223	CERAMIC VIBRATOR, CST4.00MGW CERALOCK
CT01	4822 124 41539	PD26-CAPACITORS ELECT 47μF 16V
CT02	4822 122 30103	CERAMIC 0.022μF +80%-20% 50V
CT04	4822 122 40617	CERAMIC 0.1μF +80%-20%
CT06	4822 122 30103	CERAMIC 0.022μF +80%-20% 50V
CT07	4822 122 40617	CERAMIC 0.1μF +80%-20%
QT01	4822 209 72503	PD26-SEMICONDUCTORS IC HI SPEED 74HC04
QT02	4822 209 73951	IC RESET PST523D (4.2V LOW)
JT02	4822 265 20354	PD26-MISCELLANEOUS TERMINAL 1P RCA GOLD
JT03	4822 265 20629	TERMINAL 1P RCA ORANGE
JT04	4822 267 31219	JACK OPTICAL TOX174
LT01	4822 158 60605	FERRITE CORE, BEADS
LT02	4822 142 60388	PULSE TRANSFORMER
CN01	4822 124 90357	PP16-POWER / AUDIO CIRCUIT BOARD PP16-CAPACITORS ELECT 2 2μF 50V
C651	4822 123 30093	MICA 5PF ±0.5PF 500V
C652	4822 123 30093	MICA 5PF ±0.5PF 500V
C653 ?	4822 124 23398	ELECT 220μF 10V
C656 C657 ?	4822 124 22572	ELECT 100μF 63V
C660		
C661	4822 122 40617	CERAMIC 0.1μF +80% -20%
C663	4822 124 90058	ELECT 47μF 25V
C664	4822 124 90058	ELECT 47μF 25V
C665	4822 122 40617	CERAMIC 0.1μF +80% -20%
C834	4822 124 22239	ELECT 3300μF 25V
C835	4822 124 22239	ELECT 3300μF 25V
C836	4822 124 22239	ELECT 3300μF 25V
C837	4822 124 90364	ELECT 220μF 16V
C838	4822 124 90364	ELECT 220μF 16V
C839	4822 124 23649	ELECT 470μF 25V
C842	4822 124 90388	ELECT 3300μF 16V
C845	4822 124 90364	ELECT 220μF 16V
C853	4822 124 42037	ELECT 6800μF 35V
C854	4822 124 42037	ELECT 6800μF 35V
C855	4822 209 70226	IC NJM5534D
C856	4822 209 70226	IC NJM5534D
C857	4822 124 22734	ELECT 47μF 50V
C858	4822 124 22734	ELECT 47μF 50V
C863	4822 124 23363	ELECT 220μF 6.3V
C864	4822 124 90364	ELECT 220μF 16V
C872	4822 124 90364	ELECT 220μF 16V
C873	4822 124 23363	ELECT 220μF 6.3V

REF. DESIG.	PART NO.	DESCRIPTION
R653	4822 050 24642	PP16-RESISTORS 4.64KΩ ±2% 1/4W
R654	4822 050 24642	4.64KΩ ±2% 1/4W
R655	4822 050 24643	46.4KΩ ±2% 1/4W
R656	4822 050 24643	46.4KΩ ±2% 1/4W
R657	4822 050 21542	1.54KΩ ±2% 1/4W
R658	4822 050 21542	1.54KΩ ±2% 1/4W
R659	4822 050 21001	100Ω ±2% 1/4W
R660	4822 050 21001	100Ω ±2% 1/4W
R661	4822 050 21003	10KΩ ±2% 1/4W
R662	4822 050 21003	10KΩ ±2% 1/4W
R663	4822 050 22153	21.5KΩ ±2% 1/4W
R664	4822 050 22153	21.5KΩ ±2% 1/4W
R691 ?	4822 111 90731	47Ω ±2% 1/4W FUSE
R694		
R801	4822 117 10229	6.81KΩ ±2% 1/4W
R802	4822 117 10229	6.81KΩ ±2% 1/4W
R803 ?	4822 050 21782	1.78KΩ ±2% 1/4W
R806		
R807	4822 050 21212	1.21KΩ ±2% 1/4W
R808	4822 050 21212	1.21KΩ ±2% 1/4W
R809	4822 050 21782	1.78KΩ ±2% 1/4W
R810	4822 050 21782	1.78KΩ ±2% 1/4W
R811	4822 050 21212	1.21KΩ ±2% 1/4W
R812	4822 050 21212	1.21KΩ ±2% 1/4W
R813	4822 111 90967	4.7Ω ±5% 1/4W FUSE [00B]
R814	4822 111 90967	4.7Ω ±5% 1/4W FUSE [00B]
R862	4822 050 21002	1KΩ ±2% 1/4W
R863	4822 050 21002	1KΩ ±2% 1/4W
R864	4822 050 21782	1.78KΩ ±2% 1/4W
R866	4822 050 21212	1.21KΩ ±2% 1/4W
R867	4822 050 25621	562Ω ±2% 1/4W
R872	4822 050 25621	562Ω ±2% 1/4W
R873	4822 050 21002	1KΩ ±2% 1/4W
R874	4822 050 21212	1.21KΩ ±2% 1/4W
R875	4822 050 21002	1KΩ ±2% 1/4W
R876	4822 050 21782	1.78KΩ ±2% 1/4W
D651	4822 130 33305	PP16-SEMICONDUCTORS DIODE 1SS176, MA165, 1SS245 30V 0.1A
D831	4822 130 80907	DIODE S2VB20
D841		
D844	4822 130 32508	DIODE RL103E .DSF10C
D851		
D854	4822 130 33074	DIODE 30DF-2 200V 3A
D855	4822 130 33664	ZENER DIODE HZ6L (3) 6.2V
D856	4822 130 33664	ZENER DIODE HZ6L (3) 6.2V
D861	4822 130 82956	ZENER DIODE HZ2CLL 2.4V (±0.2V)
D871	4822 130 82956	ZENER DIODE HZ2CLL 2.4V (±0.2V)
D872	4822 130 33759	ZENER DIODE 04A24.7, RD4.7ES, MTZJ4.7B
ON01	4822 209 83312	IC RELAY DRIVE TA7317P
O651	4822 209 70226	IC NJM5534D
O652	4822 209 70226	IC NJM5534D
O653	4822 130 43023	TRANSISTOR 2SA1306 (O, Y)
O654	4822 130 43311	TRANSISTOR 2SC3298 (O, Y)
O655	4822 130 60107	TRANSISTOR 2SA1048 (Y, GR)
O656	4822 130 60839	TRANSISTOR 2SC2458 (Y, GR)
O657	4822 130 60107	TRANSISTOR 2SC1048 (Y, GR)
O658	4822 130 60839	TRANSISTOR 2SC2458 (Y, GR)
O659	4822 130 43311	TRANSISTOR 2SC3298 (O, Y)
O660	4822 130 60839	TRANSISTOR 2SC2458 (Y, GR)
O663	4822 130 60839	TRANSISTOR 2SC2458 (Y, GR)
O664	4822 130 60839	TRANSISTOR 2SC2458 (Y, GR)

REF. DESIG.	PART NO.	DESCRIPTION
Q871	4822 130 43023	TRANSISTOR 2SA1306 (O, Y)
Q872	4822 130 60107	TRANSISTOR 2SA1048 (Y, GR)
Q873	4822 130 60107	TRANSISTOR 2SA1048 (Y, GR)
F831	4822 253 30402	PP16-MISCELLANEOUS FUSE T 800MA BS [00B]
F832	4822 253 30402	FUSE T 800MA BS [00B]
F841	4822 253 30402	FUSE T 800MA BS [00B]
F851	4822 253 30402	FUSE T 800MA BS [00B]
F852	4822 253 30402	FUSE T 800MA BS [00B]
J602	4822 267 30955	JACK 2P RCA
L651	4822 280 20448	RELAY DC9V RA-9W-K
L653	4822 158 60605	FERRIT CORE, BEADS
L654	4822 158 60605	FERRIT CORE, BEADS
ST01	4822 277 21559	SLIDE SWITCH, REMOTE INT/ EXT
Q831	4822 209 62762	PP26-REGULATOR CIRCUIT BOARD PP26-SEMICONDUCTORS IC REG NJN7909FA -9V 1A
Q832	4822 209 62761	IC REG NJM7809FA +9V 1A
Q841	4822 209 31631	IC REG NJM7805FA +5V 1A
GH02	4822 121 43732	PS26-POWER SWITCH CIRCUIT BOARD PS26-CAPACITORS FILM 0.01μF ±20% 250V
LH01	4822 157 70419	PS26-MISCELLANEOUS NOISE FILTER, CHOKO
SH02	4822 276 11141	PUSH SWITCH, POWER
CF03	4822 124 22274	PU16-CONTROL / DECODER CIRCUIT BOARD PU16-CAPACITORS ELECT 4.7μF 50V
CF04	4822 124 41539	ELECT 47μF 16V
CF05	5322 122 32654	CERAMIC 0.022μF ±10% CHIP
CF06	5322 122 32654	CERAMIC 0.022μF ±10% CHIP
CF07	4822 124 41539	ELECT 47μF 16V
CF08	5322 122 32654	CERAMIC 0.022μF ±10% CHIP
CF09	4822 124 41539	ELECT 47μF 16V
CF10	5322 122 32654	CERAMIC 0.022μF ±10% CHIP
CF13	4822 124 41539	ELECT 47μF 16V
CF14	5322 122 32654	CERAMIC 0.022μF ±10% CHIP
CF17 ?	4822 122 32669	CERAMIC 0.047μF +80%-20% CHIP
CF19		
CF20	5322 122 32654	CERAMIC 0.022μF ±10% CHIP
CF50	4822 122 32669	CERAMIC 0.047μF +80%-20% CHIP
CM01	4822 124 22274	ELECT 4.7μF 50V
CM04	5322 122 34098	CERAMIC 0.01μF ±10% CHIP
CM05	5322 122 34098	CERAMIC 0.01μF ±10% CHIP
CM07	4822 122 33714	CERAMIC 0.1μF +80%-20% CHIP
CM08	4822 122 33714	CERAMIC 0.1μF +80%-20% CHIP
CM09	5322 122 32654	CERAMIC 0.022μF ±10% CHIP
C154	4822 122 32669	CERAMIC 0.047μF +80%-20% CHIP
C155	4822 122 32669	CERAMIC 0.047μF +80%-20% CHIP
C156	4822 124 41539	ELECT 47μF 16V
C157	4822 124 41539	ELECT 47μF 16V
C501	4822 122 32694	CERAMIC 47PF ±5% CHIP
C504	4822 124 90357	ELECT 2.2μF ±5% 50V

REF. DESIG.	PART NO.	DESCRIPTION
C506	5322 122 32654	CERAMIC 0.022μF ±10% CHIP
C514	4822 122 32669	CERAMIC 0.047μF +80%-20% CHIP
C515	4822 124 22274	ELECT 4.7μF 16V
C521	4822 124 41539	ELECT 4.7μF 16V
C522	4822 122 32669	CERAMIC 0.047μF +80%-20% CHIP
C523	4822 124 41539	ELECT 4.7μF 16V
C524	4822 122 32669	CERAMIC 0.047μF +80%-20% CHIP
C525	4822 122 32669	CERAMIC 0.047μF +80%-20% CHIP
PV16-RESISTOR		
RF03	4822 111 90895	10KΩ ±5% 1/10W CHIP
RF04	4822 111 90907	22KΩ ±5% 1/10W CHIP
RF05	4822 111 90895	10KΩ ±5% 1/10W CHIP
RF07	4822 111 90895	10KΩ ±5% 1/10W CHIP
RF09	4822 111 90895	10KΩ ±5% 1/10W CHIP
RF12	4822 111 90918	4.7KΩ ±5% 1/10W CHIP
RF13	4822 111 90918	1MΩ ±5% 1/10W CHIP
RF15	4822 111 90918	1MΩ ±5% 1/10W CHIP
RF22	4822 111 90967	4.7Ω ±5% 1/4W FUSE
RF23	4822 111 90895	10KΩ ±5% 1/10W CHIP
RF25	4822 111 90896	100KΩ ±5% 1/10W CHIP
RF26	4822 111 90895	10KΩ ±5% 1/10W CHIP
RF29	4822 111 90895	10KΩ ±5% 1/10W CHIP
RF30	4822 111 90895	10KΩ ±5% 1/10W CHIP
RF41	4822 111 90895	10KΩ ±5% 1/10W CHIP
RF48	4822 111 90919	47KΩ ±5% 1/10W CHIP
RF49	4822 111 90919	2.2KΩ ±5% 1/10W CHIP
RF50	4822 111 90896	100KΩ ±5% 1/10W CHIP
RF51	4822 111 90896	100KΩ ±5% 1/10W CHIP
RF52	4822 111 90895	10KΩ ±5% 1/10W CHIP
RF53	4822 111 90895	10KΩ ±5% 1/10W CHIP
RF99	4822 111 90895	10KΩ ±5% 1/10W CHIP
RM01	4822 111 90919	47KΩ ±5% 1/10W CHIP
RM02	4822 111 90918	4.7KΩ ±5% 1/10W CHIP
RM03	4822 111 90918	4.7KΩ ±5% 1/10W CHIP
RM06	4822 111 90918	4.7KΩ ±5% 1/10W CHIP
RM08	4822 111 90918	4.7KΩ ±5% 1/10W CHIP
RM11	4822 111 90918	4.7KΩ ±5% 1/10W CHIP
R151	4822 111 90918	4.7KΩ ±5% 1/10W CHIP
R152	4822 111 90919	47KΩ ±5% 1/10W CHIP
R153	4822 111 90896	100KΩ ±5% 1/10W CHIP
R154	4822 111 90897	1MΩ ±5% 1/10W CHIP
R155	4822 111 90896	100KΩ ±5% 1/10W CHIP
R156	4822 116 83255	3.3KΩ ±5% 1/10W CHIP
R157	4822 111 90922	5.6KΩ ±5% 1/10W CHIP
R158	4822 111 91368	120KΩ ±5% 1/10W CHIP
R159	4822 116 83609	390KΩ ±5% 1/10W CHIP
R160	4822 111 90899	15KΩ ±5% 1/10W CHIP
R161	4822 111 90918	4.7KΩ ±5% 1/10W CHIP
R162	4822 111 90896	100KΩ ±5% 1/10W CHIP
R163	4822 111 90919	47KΩ ±5% 1/10W CHIP
R164	4822 111 91075	1.2KΩ ±5% 1/10W CHIP
R165	4822 111 91368	120KΩ ±5% 1/10W CHIP
R501	4822 111 90906	2.2KΩ ±5% 1/10W CHIP
R502	4822 111 90907	22KΩ ±5% 1/10W CHIP
R503	4822 111 90897	1MΩ ±5% 1/10W CHIP
R504	4822 116 81011	75Ω ±5% 1/10W CHIP
R505	4822 111 90916	3.9KΩ ±5% 1/10W CHIP
R506	4822 111 90895	10KΩ ±5% 1/10W CHIP
R507	4822 111 90908	220KΩ ±5% 1/10W CHIP
R508	4822 111 91369	1.5KΩ ±5% 1/10W CHIP
R509	4822 111 90894	1KΩ ±5% 1/10W CHIP
R510	4822 111 90894	1KΩ ±5% 1/10W CHIP
R520	4822 111 90967	4.7Ω ±5% 1/4W FUSE
R523	4822 111 90892	0Ω ±5% 1/10W CHIP

REF. DESIG.	PART NO.	DESCRIPTION
R525	4822 111 90894	1KΩ ±5% 1/10W CHIP
R574	4822 111 90892	0Ω ±5% 1/10W CHIP
PV16-SEMICONDUCTORS		
DM02	4822 130 32635	DIODE MA-151K CHIP
DM03	4822 130 32866	DIODE MA-151WA CHIP
DM05	4822 130 32635	DIODE MA-151K CHIP
DM06	4822 130 32866	DIODE MA151WA CHIP
DM08	4822 130 32866	DIODE MA151WA CHIP
D151	4822 130 32868	DIODE MA153 CHIP
QF01	4822 209 62768	MICROPROCESSOR MAIN μ-COM MC68HC11A0P
QF02	4822 209 62756	IC MC68HC24
QF04	4822 130 50487	IC RECTIFIER OTP (FOR CD-10)
QF05	5322 209 71555	IC MB74HC373
QF06	4822 209 51273	IC MSM2816A EE- PROM
QF08	4822 209 31928	IC CMOS 74HC00
QF09	4822 209 31928	IC CMOS 74HC00
QF11	4822 209 73951	IC RESET PST523D (4.2V LOW)
QF13	4822 130 60941	DIGITAL TRANSISTOR DTA114EK
QF14	4822 130 90451	DIGITAL TRANSISTOR DTC114EK
QF15	4822 130 61437	DIGITAL TRANSISTOR DTC114YK
QF16	4822 130 61436	DIGITAL TRANSISTOR DTA114YK
QM01	4822 209 83803	IC LB1645N
QM02	4822 209 83803	IC LB1645N
QM03	4822 209 31928	IC CMOS 74HC00 FLAT
QM04	4822 130 90449	DIGITAL TRANSISTOR DTC144
QM05	4822 130 60941	DIGITAL TRANSISTOR DTA114EK
QM07	4822 130 90449	DIGITAL TRANSISTOR DTC144
Q151	4822 209 83357	IC QFP NJM4560M
Q152	4822 130 42733	TRANSISTOR 2SA1162(G) CHIP
Q153	4822 130 61799	DIGITAL TRANSISTOR DTA144TK
Q501	4822 209 63453	IC DEM/ERCO SAA7310 QFP
Q502	4822 209 73952	IC D-RAM MB81416C-15, MN4264P-15
Q503	4822 130 61438	TRANSISTOR 2SA1005 (L,R)
Q504	4822 209 30439	IC ADOC PCF323P
Q505	4822 209 63379	IC 74HC08 FLAT
Q568	4822 209 31012	IC RESET PST529C (4.5V LOW)
PV16-MISCELLANEOUS		
L501	4822 152 20647	CHOKO COIL 2.2μH
XF01	4822 242 72066	CERAMIC VIBRATOR 8MHZ CST8.00MHZ(MT)
PV16-SERVO CURCUIT BOARD		
PV16-CAPACITORS		
C101	4822 121 42327	FILM 470PF ±5% 50V
C103	4822 122 40306	CERAMIC 0.047μF +80%-20% 50V
C110	4822 124 41539	ELECT 47μF 16V
C113	4822 122 40306	CERAMIC 0.047μF +80%-20% 50V
C114	4822 122 40306	CERAMIC 0.047μF +80%-20% 50V
C126	4822 124 41539	ELECT 47μF 16V
C128	4822 122 40306	CERAMIC 0.047μF +80%-20% 50V
C132	4822 122 40306	CERAMIC 0.047μF +80%-20% 50V
C133	4822 124 41539	ELECT 47μF 16V
C134	4822 124 41539	ELECT 47μF 16V
C135	4822 122 40306	CERAMIC 0.047μF +80%-20% 50V
C136	4822 124 41539	ELECT 47μF 16V
C137	4822 122 40306	CERAMIC 0.047μF +80%-20% 50V
C140	4822 124 41539	ELECT 47μF 16V

REF. DESIG.	PART NO.	DESCRIPTION
PV16-RESISTORS		
R116	4822 115 90194	15Ω ±2%/14W FUSE
R134	4822 100 20681	2.2KΩ TRIMMING LASER ADJ
R136	4822 100 11352	22KΩ TRIMMING FOCUS OFFSET ADJ
R141	4822 111 90967	4.7Ω ±5% 1/4W FUSE
R146	4822 111 90967	4.7Ω ±5% 1/4W FUSE
PV16-SEMICONDUCTORS		
D132	4822 130 80272	ZENER DIODE 04AZ7.5, RD7.5ES, MTZJ7 5C
D133	4822 130 80272	ZENER DIODE 04AZ7.5, RD7.5ES, MTZJ7 5C
D134	4822 130 32508	DIODE RL103E, DSF10C
Q101	4822 209 30436	IC HF & FOC TDA8808 QFP
Q102	4822 130 61441	TRANSISTOR 2SD1862 (Q, R)
Q103	4822 209 30437	IC RADIAL TDA8809 QFP
Q106	4822 209 62755	IC POWER OP TCA0372
Q108	4822 209 30442	IC REG NJM79L06A 6V 0.5A
PV16-MISCELLANEOUS		
J101	4822 267 31465	JACK, FPC CONNECT
PV16-KEY-SENS / DISPLAY CIRCUIT BOARD		
PV16-CAPACITORS		
CY01	4822 122 32486	CERAMIC 0.01μF +80%-20% 50V
CY02	4822 124 90354	ELECT 100μF 16V
CY04	4822 124 22571	ELECT 10μF 50V
CY05	5322 122 32265	CERAMIC 100PF ±5% 50V
CY06	5322 122 32265	CERAMIC 100PF ±5% 50V
CY07	4822 124 22274	ELECT 4.7μF 50V
CY11	4822 124 90353	ELECT 100μF 10V
CY12	4822 122 30103	CERAMIC 0.022μF +80%-20% 50V
CY13	4822 122 30103	CERAMIC 0.022μF +80%-20% 50V
CY52	4822 124 41246	ELECT 47μF 16V
CY61	4822 122 30103	CERAMIC 0.022μF +80%-20% 50V
CY62	4822 124 90365	ELECT 220μF 25V
CY63	4822 124 41536	ELECT 100μF 35V
CY70	4822 122 30103	CERAMIC 0.022μF +80%-20% 50V
CY81	4822 124 21894	ELECT 10μF 16V
CY82	4822 124 21894	ELECT 10μF 16V
PV16-SEMICONDUCTORS		
DY01	4822 130 33305	DIODE 1SS176, MA165, 1SS254 30V 0.1A
DY05	4822 130 33305	DIODE 1SS176, MA165, 1SS254 30V 0.1A
DY08	4822 130 80319	ZENER DIODE 04AZ9.1, RD9.1ES, MTZJ9 1C
DY09	4822 130 80319	ZENER DIODE 04AZ5.6, RD5.6ES, MTZJ5 6B
DY54	4822 130 33948	DIODE S5688G VRM=400V IO=1A
DY61	4822 130 80839	DIODE S5688G VRM=400V IO=1A
DY62	4822 130 80839	DIODE S5688G VRM=400V IO=1A
DY81	4822 130 80326	L.E.D LT3D08 RED
DY82	4822 130 33305	DIODE 1SS176, MA165, 1SS254
QY01	4822 209 62769	MICROPROCESSOR μPD7537A
QY05	4822 209 62763	IC TC74HC164BP
4822 130 63211	DIGITAL TRANSISTOR DTA114TS	
QY11	4822 130 42715	TRANSISTOR 2SA608SP, 2SA1048, 2SA1309, 2SA933S
QY51	4822 130 42715	DIGITAL TRANSISTOR DTA114ES
QY52	4822 130 61227	TRANSISTOR 2SC536SP, 2SC2458, 2SC3311, 2SC1740S
QY53	4822 130 42298	DIGITAL TRANSISTOR DTA114ES
QY81	4822 130 61227	DIGITAL TRANSISTOR DTA114ES
QY82	4822 130 63211	DIGITAL TRANSISTOR DTA114TS

REF. DESIG.	PART NO.	DESCRIPTION
QY83	4822 130 60588	DIGITAL TRANSISTOR DTC114ES
QY84	4822 130 42715	2SA608SP, 2SA1048, 2SA1309, 2SA933S
PV16-MISCELLANEOUS		
SY01	4822 276 20508	PUSH SWITCH, REPEAT
SY02	4822 276 20508	PUSH SWITCH, FTS
SY03	4822 276 20508	PUSH SWITCH, OPEN
SY04	4822 276 20508	PUSH SWITCH, PREV TRACK
SY05	4822 276 20508	PUSH SWITCH, NEXT TRACK
SY06	4822 276 20508	PUSH SWITCH, PAUSE
SY07	4822 276 20508	PUSH SWITCH, PLAY/REPLAY
SY08	4822 276 20508	PUSH SWITCH, DISP
SY09	4822 276 20508	PUSH SWITCH, STOP/CM
VY01	4822 130 90441	DISPLAY UNIT
XY01	4822 242 73695	CERAMIC VIBRATOR, CSB590P 590KHZ
ZY01	4822 130 82139	REMOTE RECEIVER PAS-C0617

NOTE ON SAFETY:

Symbol ▲ Fire or electrical shock hazard. Only original parts should be used to replace any part marked with symbol ▲. Any other component substitution (other than original type), may increase risk of fire or electrical shock hazard.