

COMPACT
disc
DIGITAL AUDIO

381

SERVICE
MANUAL

CD-54

marantz®

model CD-54

Compact Disc Digital Audio Player

MARANTZ DESIGN AND SERVICE

Using superior design and selected high grade components, MARANTZ company has created the ultimate in stereo sound. Only **original MARANTZ parts** can insure that your MARANTZ product will continue to perform to the specifications for which it is famous.

Parts for your MARANTZ equipment are generally available to our National Marantz Subsidiary or Agent.

ORDERING PARTS:

Parts can be ordered either by mail or by telex. In both cases, MARANTZ part number has to be specified. If you order by mail, fulfil MARANTZ order forms.

MARANTZ S.A.
EUROPEAN PARTS DEPARTMENT
2, Avenue Leopold III
B-7120 PERONNES-lez-BINCHE
BELGIUM
TWX: 57589 SEPLT B

SUPERSCOPE NATIONAL PARTS DEPARTMENT
20525 Nordhoff Street
Chatsworth, California 91311
Phone: 1-800-423-5108
Phone: 1-213-998-9333

The following information must be supplied to eliminate delays in processing your order:

1. Complete address
2. Complete part numbers and quantities required
3. Description of parts
4. Model number for which part is required
5. Way of shipment
6. Signature: any order form or telex must be signed otherwise such part order will be considered as null and void.

PARTS ORDERING:

Parts may be ordered from the following addresses:

Marantz S.A.
European Parts Dept.
2, Avenue Léopold III
B-7120 Péronnes-lez-Binche
Belgium
Telex: 57589

Marantz Germany GMBH
Max Planckstrasse, 22
6072 Dreieich 1
West Germany
Telex: 4185316

EUROPE

Marantz France
4 rue Bernard Palissy
92600 Asnières
France
Telex: 611651

Marantz Denmark
Bregnerødvej 132b
3460 Birkerød
Denmark
Telex: 39137

Marantz GMBH Austria
Wiedner Hauptstrasse 98
1050 Wien
Austria
Telex: 113583

Marantz S.A.
326 Avenue Louise Bte 32
1050 Brussels
Belgium
Telex: 26602

Marantz Italiana S.p.A.
Via Monte Napoleone 10
20121 Milano
Italy

Marantz Audio U.K. Ltd.
Unit 15/16
Saxon Way Industrial Estate
Moor Lane
Harmondsworth UB7 OLW
Great Britain
Telex: 935196

Marantz Belgium
45 rue Auguste Van Zande
1080 Brussels
Belgium

Marantz Svenska A.B.
Svartviksvangen 56
Traneberg - Box 12016
16112 Bromma
Sweden
Telex: 13449

AUSTRALIA

Marantz Australia Pty., Ltd.
32 Cross Street
Brookvale, N.S.W. 2100
Australia
Telex: 24121

U.S.A.

Marantz Company, Inc.
National Service Dept.
P.O. Box 577
Chatsworth, CA 91311
U.S.A.
Telex: 4720284

JAPAN

Marantz Japan, Inc.
35-1 7-chome, Sagamiono
Sagamihara-shi, Kanagawa
Japan
Telex: 22878

All of the above locations are fully equipped to take care of your total service needs. Because various countries have differing configuration requirements, it is necessary that you contact the service facility in your particular country. In the event that there is no service location listed for your country, please, contact the nearest facility for the necessary assistance.

In case of difficulties, do not hesitate to contact the Technical Department at abovementioned address.

NOTE—FOR U.S.A. ONLY

Parts for your MARANTZ stereo are generally available within 72 hours throughout the nation via a toll-free line to our National Parts Depot in California. The sales professionals who take your call immediately refer to their own desk top computer terminal and can quickly determine the availability and price information you require. If, for some reason, your order should exceed our available stock, we usually can instantly provide an alternate replacement part or current delivery information. When the order is placed and confirmed, the computer simultaneously generated "hard copy" orders at the distribution center. As hard copies come directly from the computer to the national parts depot, your requested stock is assembled and prepared for shipment and placed on the first available carrier for delivery to you.

Phone orders will eliminate mail delays, and we encourage the use of this method. If you order by mail, use MARANTZ parts order forms which are available from SUPERSCOPE NATIONAL PARTS DEPARTMENT.

marantz®

MARANTZ MODEL CD-54 COMPACT DISC

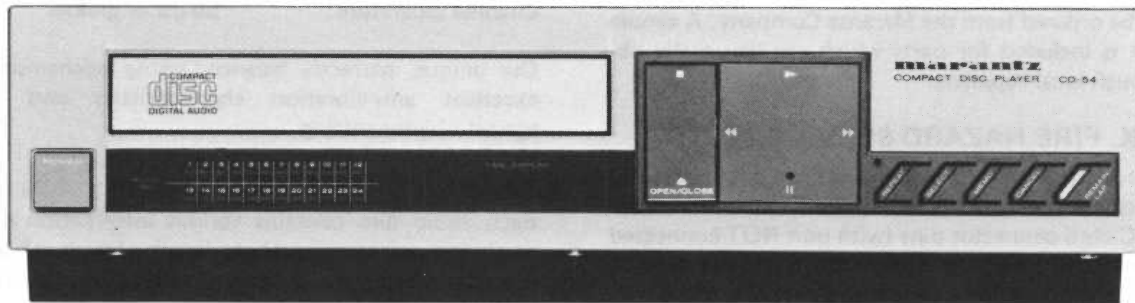

TABLE OF CONTENTS

Section	Title	Page
INTRODUCTION	4
1. SHOCK, FIRE HAZARD SERVICE TEST	4
2. P.W. Boards	4
	Measuring Equipment and Test Disc Required For Servicing	4
3. FEATURES	4
	Laser Radiation Safety	5
	Notes on Electrostatic Damage	6
	Transportation Screw	6
	Voltage Conversion	6
4. HOW TO DISASSEMBLE	7
5. ADJUSTMENT AND MEASUREMENT	8
	1. Sub Chassis Adjustment	8
	2. Servo PWB Adjustment	9
	3. Decoder PWB Adjustment	9
	4. Electrical Characteristics Measurement	10
6. WIRING DIAGRAMS	11
7. EXPLODED VIEW AND PARTS LIST	16
8. ELECTRICAL PARTS LIST	22
9. SCHEMATIC DIAGRAMS AND SEMICONDUCTORS ELECTRODES	30
10. SPECIFICATIONS	31

INTRODUCTION

This service manual are prepared for use by Authorized Warranty Station and contains service information for Marantz Compact Disc.

Servicing information and voltage data included in this manual are intended for use by the knowledgeable and experienced technician only. All instructions should be read carefully. No attempt should be made to proceed without a good understanding of the operation of the Compact Disc.

The parts list furnishes information by which replacement parts may be ordered from the Marantz Company. A simple description is included for parts which can be usually obtained through local suppliers.

1. SHOCK, FIRE HAZARD SERVICE TEST:

CAUTION: After servicing this appliance and prior to returning to customer, measure the resistance between either primary AC cord connector pins (with unit NOT connected to AC mains and its Power switch ON), and the face or front Panel of product and controls and chassis bottom.

Any resistance measurement less than 1 Megohms should cause unit to be repaired or corrected before AC power is applied, and verified before return to user/customer.

Ref. UL Standard NO. 1270. Para. 66.3. D (Mandatory Test after servicing Electrical Appliances, effective 7-1-83).

2. P.W. BOARDS

As can be seen from the circuit diagram, the chassis of your Compact Disc consists of the following units. Each unit mounted on a printed circuit board is described within the square enclosed by a bold dotted line on the circuit diagram.

1. Servo. mounted on P.W. Board P201
2. Decoder Supply. mounted on P.W. Board P501
3. Filter. mounted on P.W. Board PH01
4. Motor Control. mounted on P.W. Board PM01
5. Tray Open Close Sw. mounted on P.W. Board PM02
6. Time-Dot LED Flexble mounted on P.W. Board PR01
7. Power Switch mounted on P.W. Board PS01
8. Door Switch mounted on P.W. Board PU01
9. Key Switch. mounted on P.W. Board PY01
10. 7 Seg Driver mounted on P.W. Board PY02
11. 12 Dot Driver mounted on P.W. Board PY03

MEASURING EQUIPMENT AND TEST DISC REQUIRED FOR SERVICING

- DC voltmeter
- Distortion meter
- Low pass filter
- Spectrum analyzer
- Oscilloscope
- Phase meter
- Frequency counter
- Test disc

3. FEATURES

The compact disc system is an epoch-making audio system which makes the best of state-of-the-art digital techniques.

HIGH-PERFORMANCE

The CD-54 is extremely superior in performance to the conventional analog audio systems as demonstrated by the following characteristics.

- Frequency range: 3 Hz to 20 kHz
- Dynamic range: 90 dB or greater
- Distortion factor: 0.003%
- Wow and flutter: less than measureble limit
- Channel separation: 90 dB or greater

Our unique, perfectly balanced swing mechanism provides excellent anti-vibration characteristics and immunity against oblique setting.

VARIETY OF FUNCTIONS

Each audio disc contains various information other than music (e.g. selection numbers, length of each selection, etc.) and the CD-54 reads this information to provide many useful functions.

- **Random access programming**
Any number of selections (up to 24) can be automatically played in the desired order using the random access programming function.
- **Delete programming**
Any selections can be skipped automatically by using the delete programming function.
- **All play**
Of course, all selections can be played in the recorded order.
- **Skip**
Pressing the **PLAY(▶)** button during play automatically skips the current selection and starts playing the next selection.
- **Repeat**
Either all or selected selections can be played repeatedly.
- **Easy-to-read display**
The display shows program and operation status, elapsed time for playing each selection, time remaining to complete the program.
- **Marantz bus system**
The CD-54 is equipped with the Marantz bus system which makes it possible to build a synthesized audio system. With the Marantz bus system, the microcomputers built into each component communicate with each other to provide an easy operation system with remote control capability.

LASER RADIATION SAFETY

Protection of eyes from laser beam during servicing
This set employs a laser. Therefore, be sure to carefully follow the instructions below when servicing.

1. Laser Diode Properties

- Material: Al Ga As
- Wave Length: 0.78 μm
- Emission Duration: Continuous
- Laser Output: Max. 0.11 mW

This output is the value measured at the objective lens surface on the light pen assembly.

- Classification: Class IIIb

2. During service, do not take the subchassis block apart and do not adjust the H F amp circuit. If there is a breakdown in the H F circuit (including laser diode), replace the entire subchassis block (including H F amp circuit board).

WARNING!!

When servicing, do not approach the laser exit with the eye too closely.

In case it is necessary to confirm laser beam emission, be sure to observe from a distance of more than 30 cm from the surface of the objective lens on the light pen assembly.

LASER WARNING LABELS

The labels shown below are affixed.

- 1) DHHS Protective housing label
"DANGER - INVISIBLE LASER RADIATION WHEN OPEN. AVOID DIRECT EXPOSURE TO BEAM."
- 2) DNHW Protective housing label and laser radiation sign label
"CAUTION - HAZARDOUS LASER RADIATION WHEN OPEN AND INTERLOCK DEFETED."
"ATTENTION - RAYONNEMENT LASER DANGEREUX SI OUVERT AVEC L'ENCLenchement DE SECURITE ANNULE."

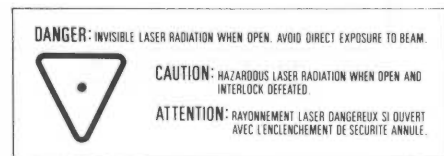

Warning Label

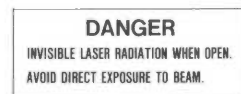
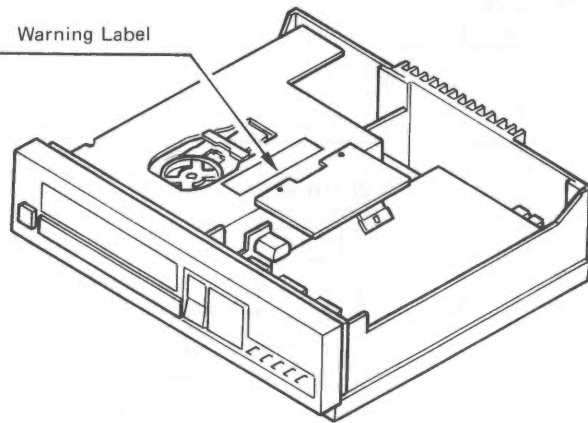

Bottom Cover

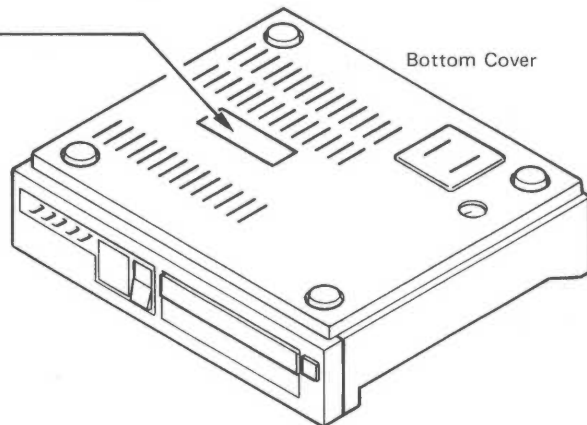

NOTES ON ELECTROSTATIC DAMAGE

When handling the laser diode of the optical pick-up or the MOS IC, be sure not to damage them with electrostatic. The electrostatic level charged in the human body and clothing varies with ambient conditions. However, simply walking will produce an electrostatic charge of more than several kV. With synthetic fiber clothing, an electrostatic charge of about 10 ~ 30 kV will be produced on a dry day. If the charged electrostatic voltage is applied to the electrode of the semi-conductor, the electrode may be damaged easily. When handling the laser diode or the MOS IC, pay attention to the following points.

1. Lay a conductive sheet on the work bench and ground it.
2. Ground the soldering iron.
3. Do not wear synthetic fiber gloves or clothing. During operation, be sure to put on the wrist strap shown below.



4. Use a conductive material to store the semi-conductors and short-circuit the electrodes or wrap them in aluminium foil to keep the potential at each electrode the same.

TRANSPORTATION SCREW

To prevent the laser pick-up from damage during transportation, the pick-up is secured with 3 screws. After unpacking, be sure to remove these screws. After servicing, do not forget to fix the laser pick-up with these screws.

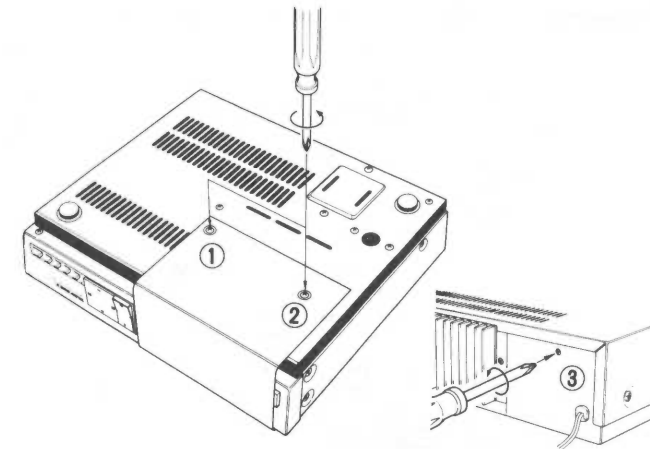

VOLTAGE CONVERSION

To convert the unit to a different power source voltage, change the position as illustrated in the drawing below.

CAUTION:

DISCONNECT POWER SUPPLY CORD FROM AC OUTLET BEFORE CONVERTING VOLTAGE. DO NOT DISASSEMBLE THE VOLTAGE SELECTOR ABSOLUTELY.

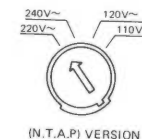
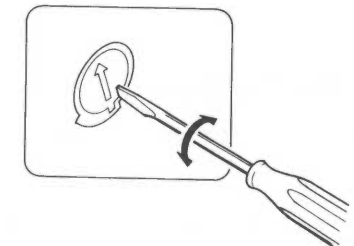

NOTE ON SAFETY:

SYMBOL Δ FIRE OR ELECTRICAL SHOCK HAZARD. ONLY ORIGINAL PARTS SHOULD BE USED TO REPLACE ANY PART MARKED WITH SYMBOL Δ . ANY OTHER COMPONENT SUBSTITUTION (OTHER THAN ORIGINAL TYPE), MAY INCREASE RISK OF FIRE OR ELECTRICAL SHOCK HAZARD.

4. HOW TO DISASSEMBLE

4-1 Removing Top, Bottom and Front Panels

Remove screws ① ~ ⑥ to remove the top panel.

Remove screws ⑦ ~ ⑨ to remove the bottom plate.

Remove screws ⑩ ~ ⑫ to remove front panel.

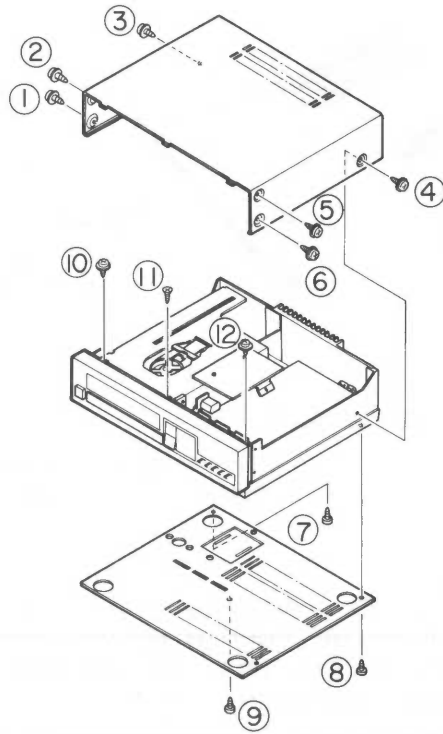

4-3 Removing Tray Mechanism

Remove screws ① ~ ③ and remove motor Chassis.

Pull out tray ④ in the direction of the arrow.

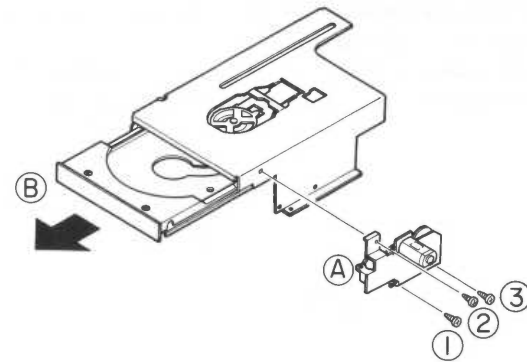

4-2 Removing Disc Tray Chassis

Remove screws ① and ② and remove shield plate ③ and PWB ④.

Remove screws ⑤ ~ ⑦ and remove the disc tray chassis.

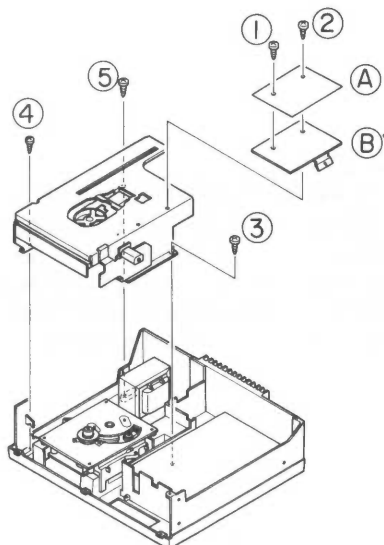

4-4 Removing Sub Chassis

Remove screws ① ~ ⑥ to remove the sub chassis.

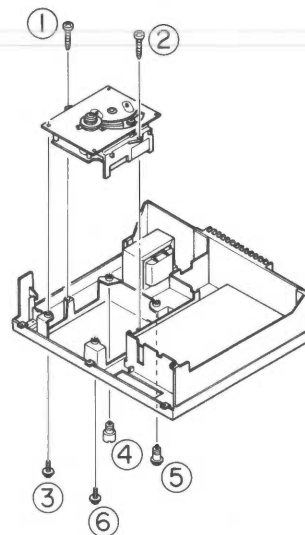

5. ADJUSTMENT AND MEASUREMENT

1. SUB CHASSIS ADJUSTMENT

1-1 Laser Output Adjustment

- (1) Play track 1 of the test disc (410055-2).
- (2) Connect a DC voltmeter between the emitter of Q239 and the ground of servo PWB (P201).
- (3) Adjust R180 (3180) so the DC voltmeter reads 500 mV \pm 30 mV.

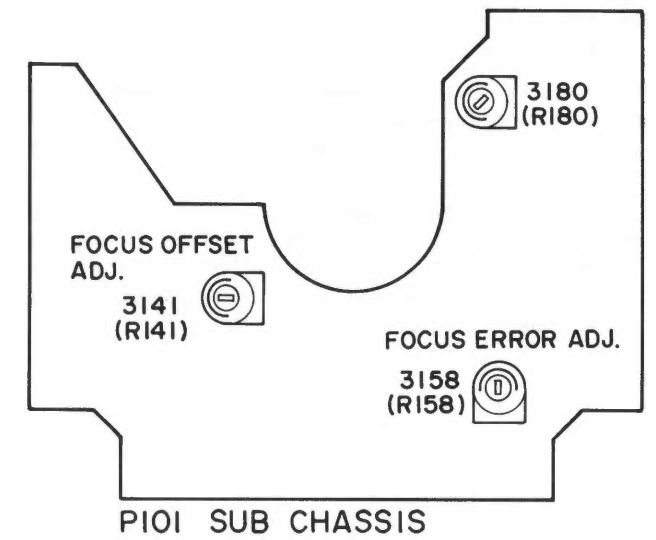
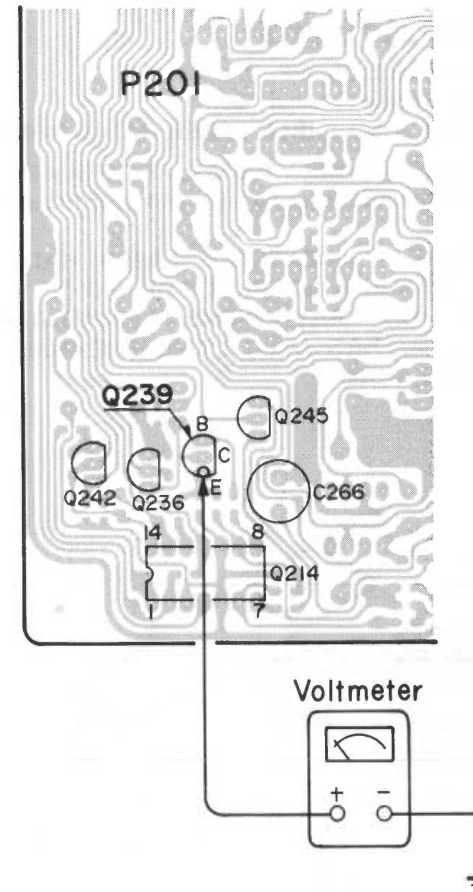

NOTE: If the test disc is not available, play the first track of a commercially available music disc.

1-2 Turntable Height Adjustment

To adjust the sub chassis objective lens movable range, proceed as follows.

- (1) Play track 1 of the test disc (410055-2).
- (2) Connect the DC voltmeter to the ends of R240 of servo PWB (P201).
- (3) The DC voltmeter should read $0\text{ V} \pm 100\text{ mV}$. If not, adjust the turntable height as follows.

- (4) Turn the adjusting screw located at the bottom of the turntable motor so the voltage at the ends of R240 is 0 V .
- (5) After adjustment, play the outer part of the disc and check the voltage at the ends of R240 is within $\pm 100\text{ mV}$ of that at the inner part.
- (6) After completion of adjustment, secure the screw with screw locking compound.

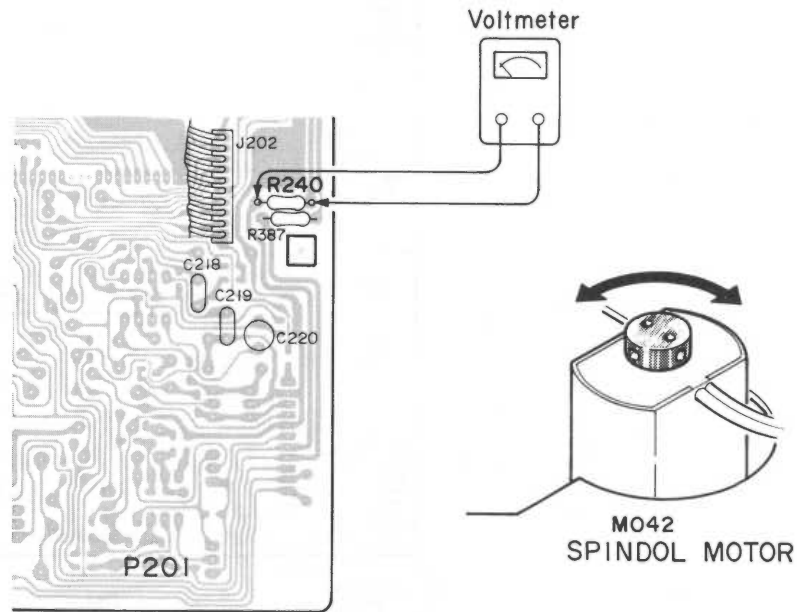

2. SERVO PWB ADJUSTMENT

2-1 Radial DC Off-set Adjustment

- (1) Play track 1 of the test disc (410055-2).
- (2) Connect an oscilloscope between the connector (J201) and the ground of the servo PWB (P201).
- (3) Adjust R315 so that the oscilloscope reads $0\text{ V} \pm 0.5\text{ V}$.

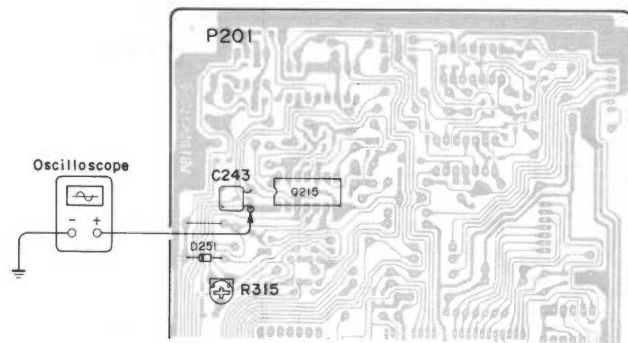

3. DECODER PWB ADJUSTMENT

3-1 PLL Circuit Adjustment

- (1) Play track 1 of the test disc (410055-2).
- (2) Connect a voltmeter between the cross point of R510 and R511 and the ground of the decoder PWB (P501).
- (3) Adjust L501 so the voltmeter reads $5\text{ V} \pm 100\text{ mV}$.

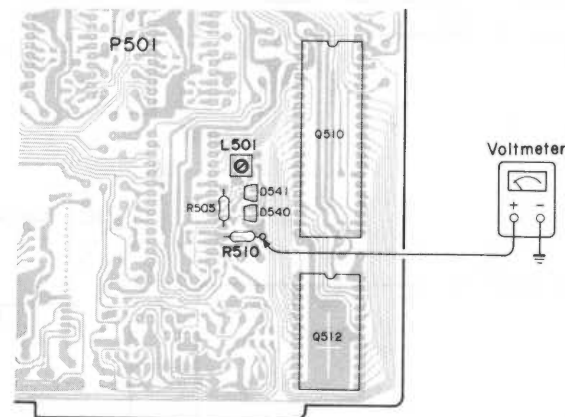

4. ELECTRICAL CHARACTERISTICS MEASUREMENT

4-1 Frequency Response

- (1) Play track 19 of the test disc (410055-2) and set the level to 0. The frequency of track 19 is 3,150 Hz.
- (2) Play the L channel of track 4 and R channel of track 8 of the test disc (410055-2) and measure the level deviation against that of track 19 (3,150 Hz) in dB. The frequencies of tracks 4 and 8 are as follows: 41 Hz, 101 Hz, 997 Hz, 3,163 Hz, 6,363 Hz, 10,007 Hz, 16,001 Hz, 19,001 Hz, 19,997 Hz.

4-2 Output Level and Channel Balance

- (1) Play track 19 of the test disc (410055-2) and read the level. Calculate the level difference between the right and left channels and the result should be the channel balance.

4-3 Distortion and Noise

- (1) Play track 4 of the test disc (410055-2) and measure the distortion. The measuring frequencies are as follows: 41 Hz, 101 Hz, 997 Hz, 3,163 Hz, 6,363 Hz, 10,007 Hz, 16,001 Hz, 19,001 Hz, 19,997 Hz.
- (2) Perform same procedures for track 8 of the test disc (410055-2).

4-4 Signal-to-noise Ratio (Dynamic Range)

- (1) Play track 5 of the test disc (410055-2), measure the distortion in dB and assume it as A. The measuring frequencies are as follows: 41 Hz, 101 Hz, 997 Hz, 3,163 Hz, 6,363 Hz, 10,007 Hz, 16,001 Hz, 19,001 Hz, 19,997 Hz.
- (2) Obtain the signal-to-noise ratio and dynamic range according to the following formula. Signal-to-noise ratio, dynamic range = $A + 24\text{ dB}$.
- (3) Perform same procedures for track 9 of the test disc (410055-2).

4-5 Channel Crosstalk Measurement

- (1) Play track 4 of the test disc and set the left channel output to 0.
- (2) Measure the non-signal level of the right channel and read the non-signal level difference against 0 dB in dB.
- (3) The measuring frequencies are as follows: 41 Hz, 101 Hz, 997 Hz, 3,163 Hz, 6,363 Hz, 10,007 Hz, 16,001 Hz, 19,001 Hz, 19,997 Hz.
- (4) Perform same procedures for track 8 of the test disc (410055-2).

6. WIARING DIAGRAMS

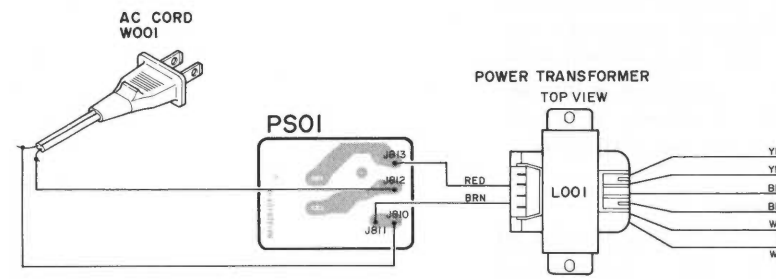

FOR (F) VERSION

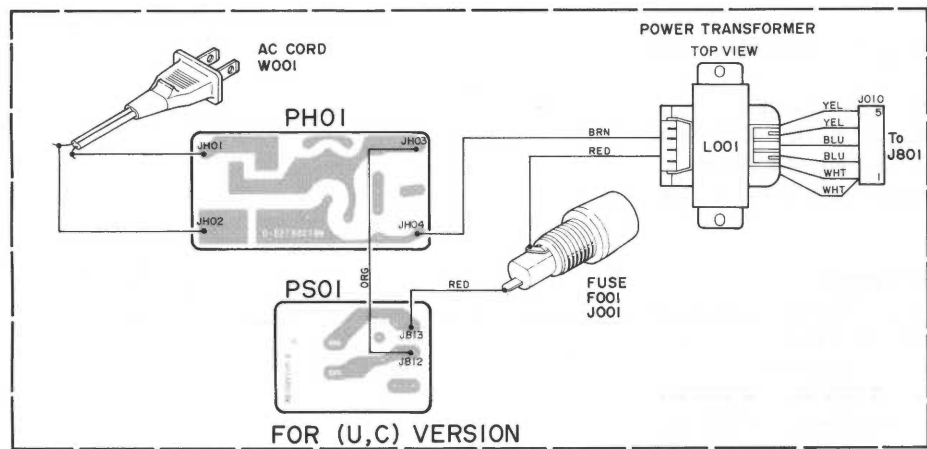

FOR (U,C) VERSION

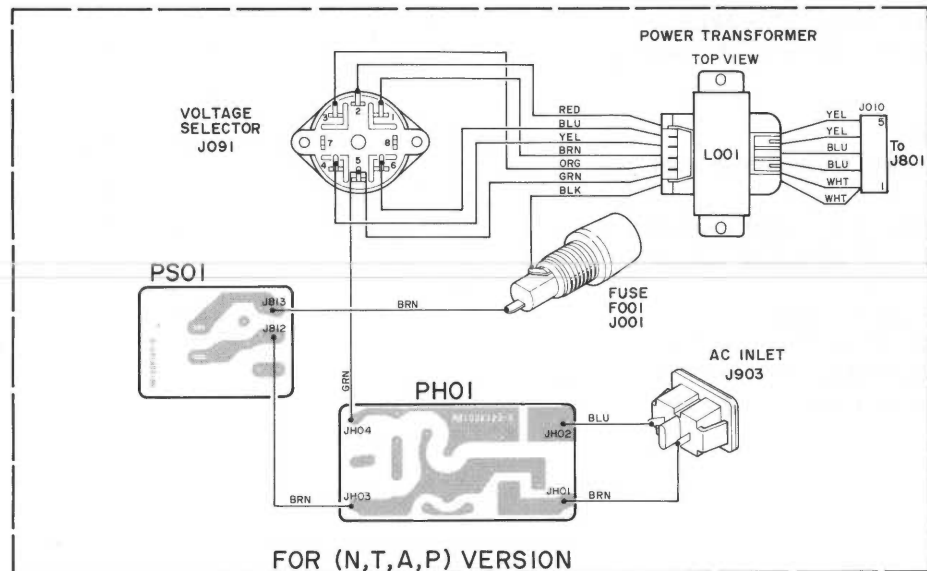

FOR (N,T,A,P) VERSION

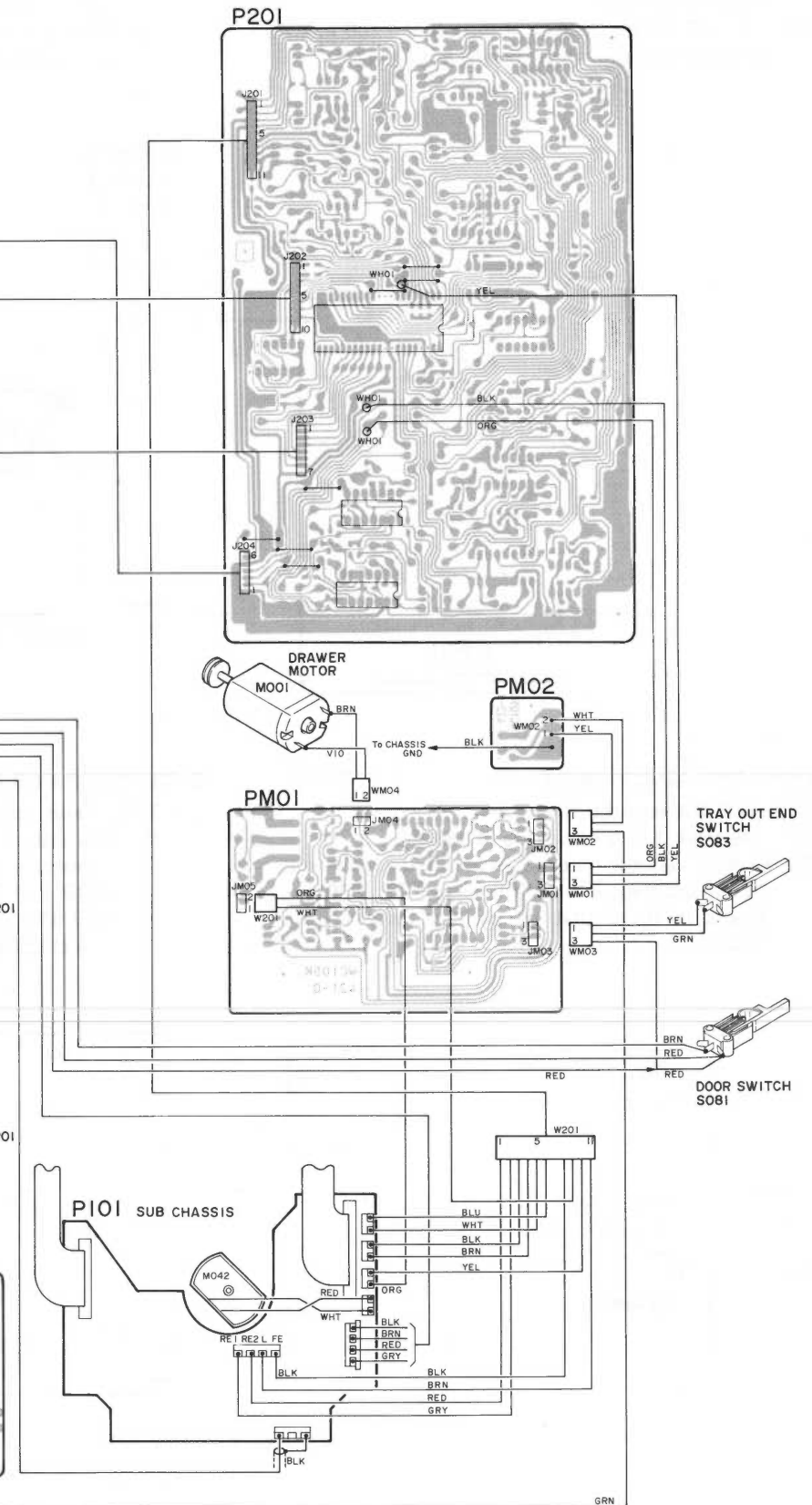
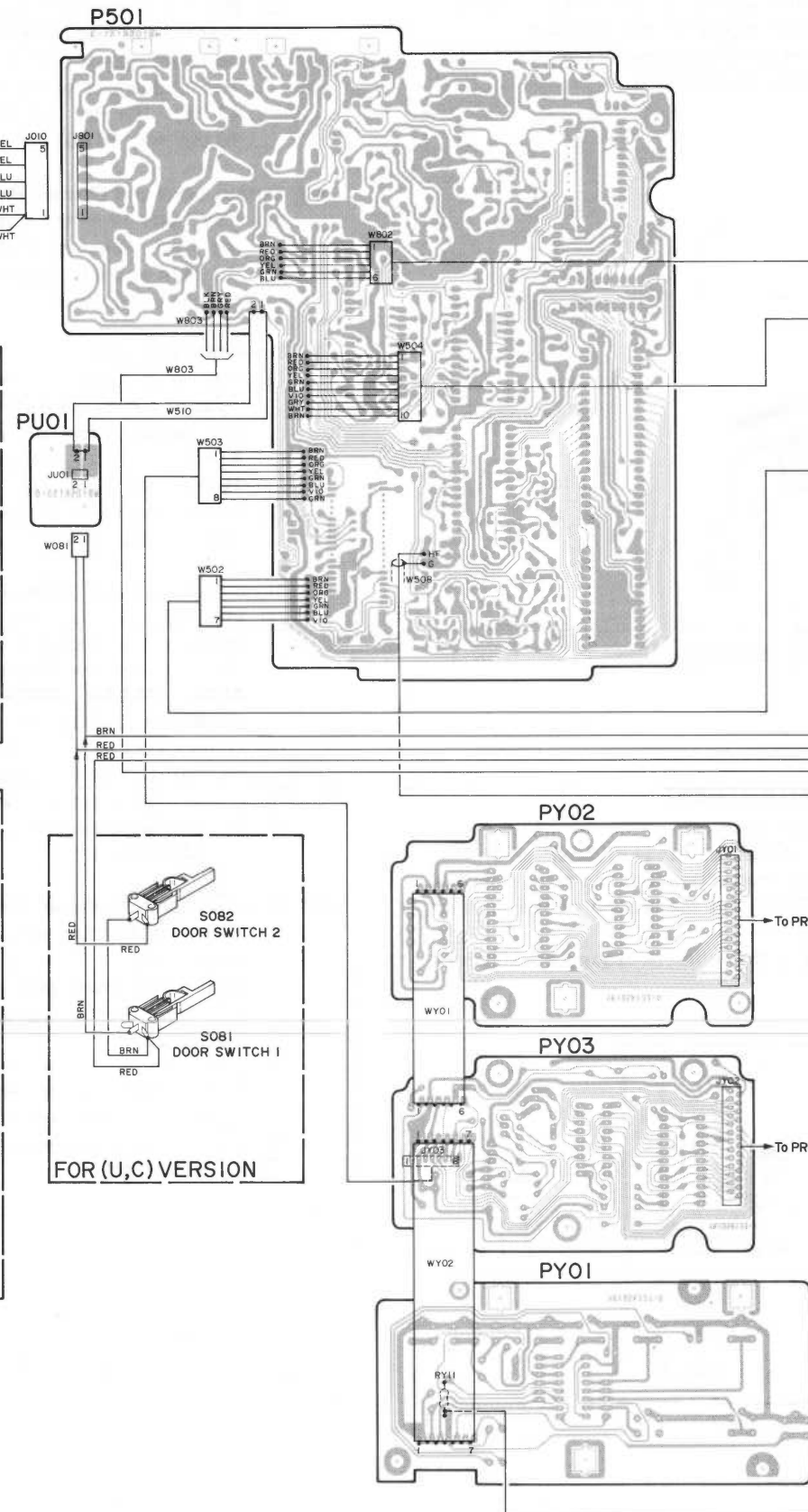

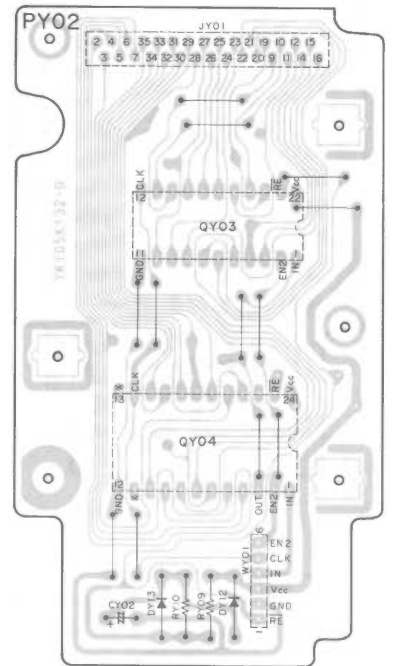
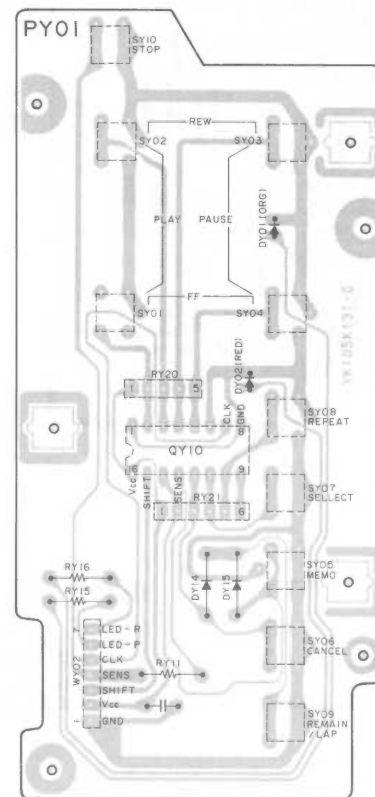
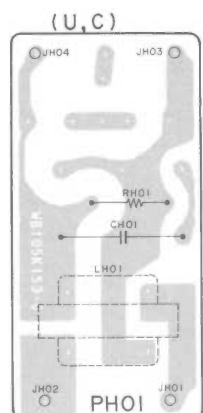
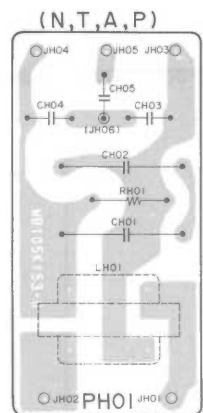
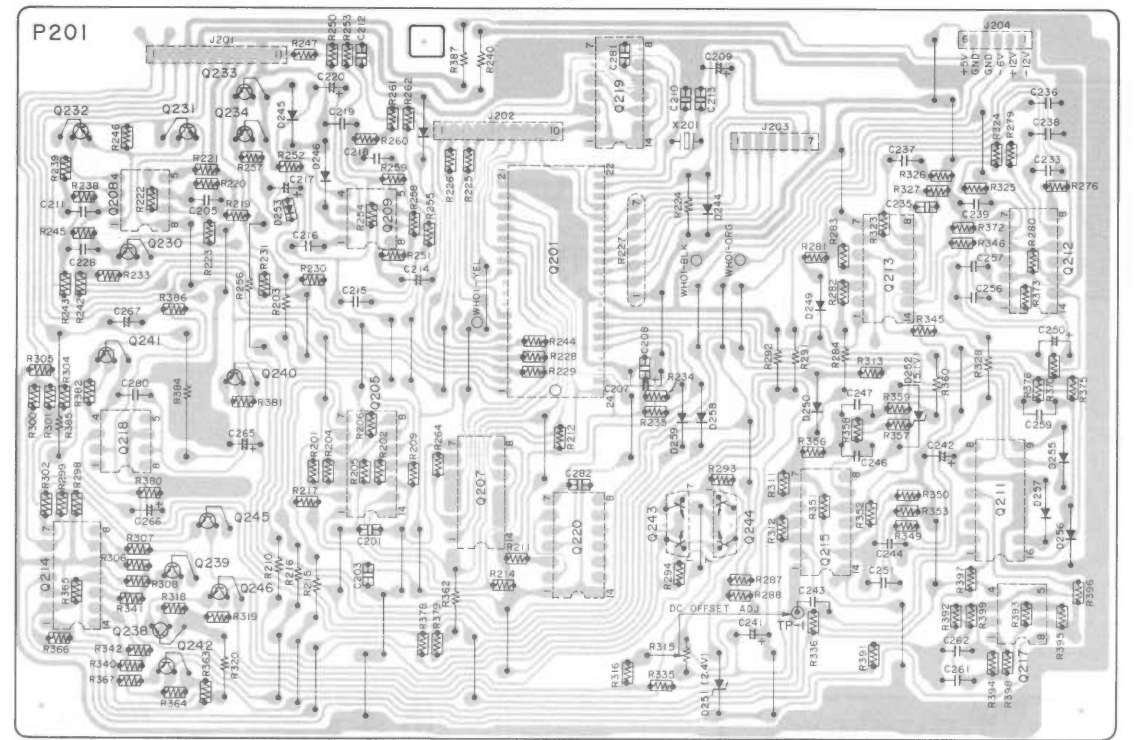
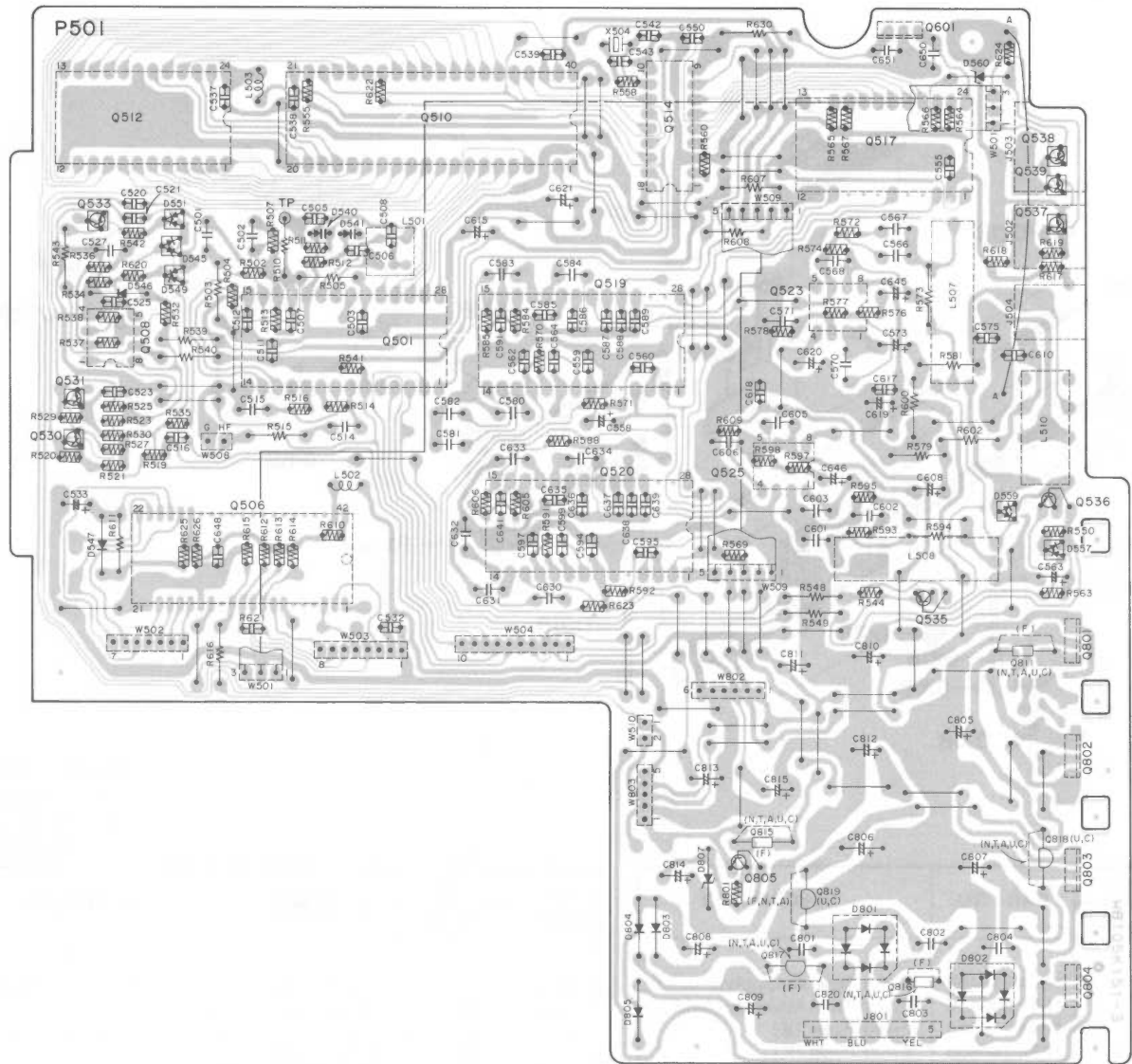

7. EXPLODED VIEWS AND PARTS LIST

[C01-99] FRONT PANEL

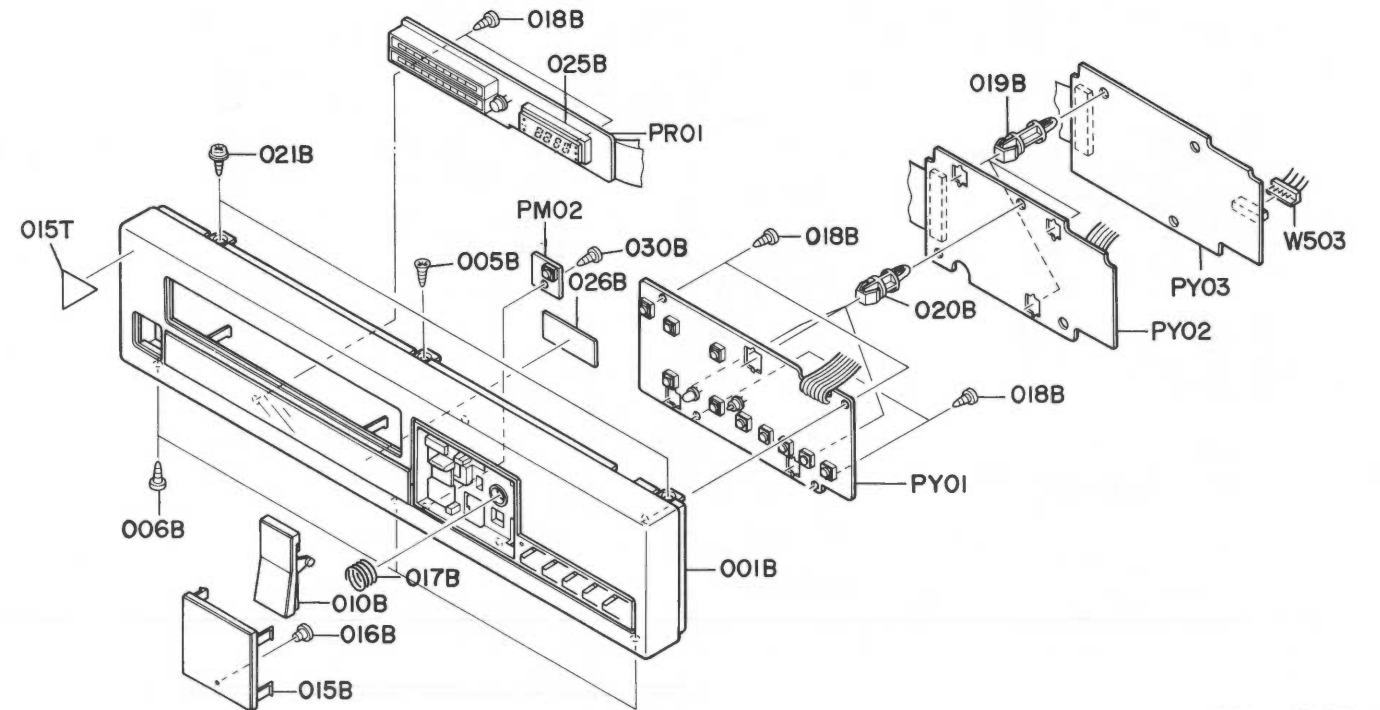
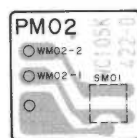
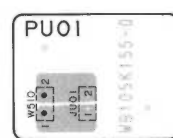
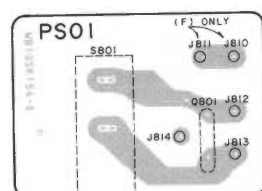
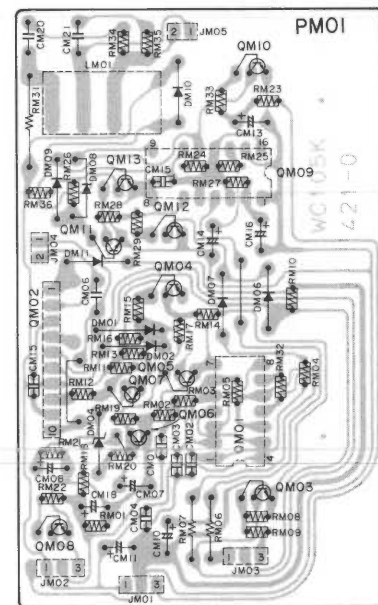
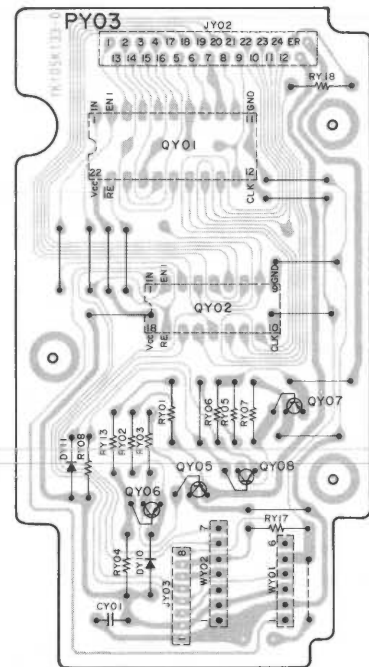
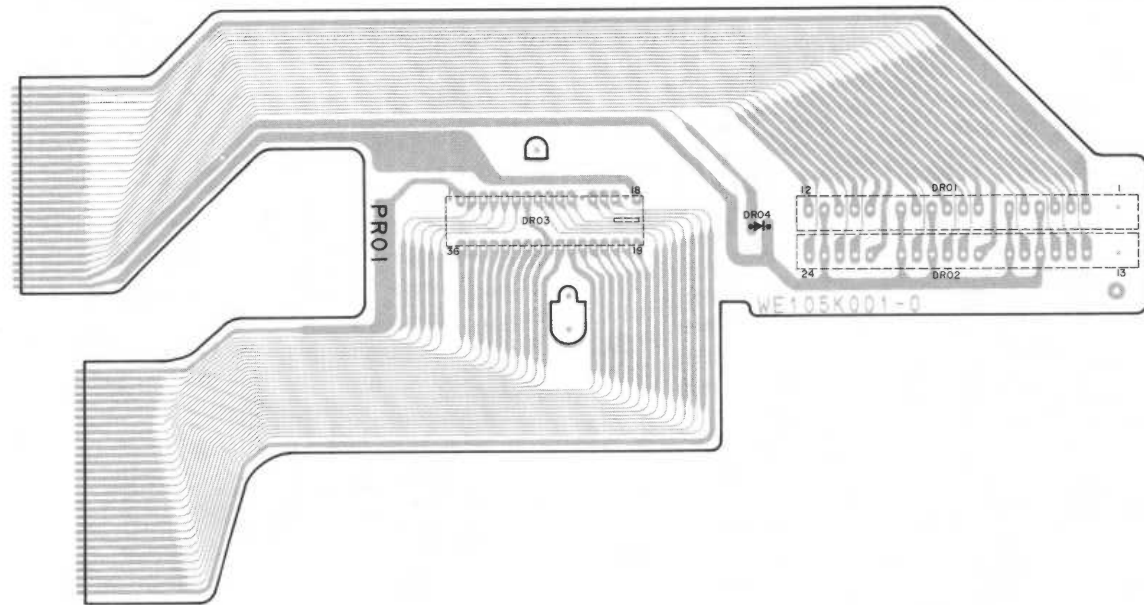

(U): for U.S.A.
(N): for Europe
(A): for Australia
(F): for Japan

REF. DESIG.	Q'TY				PART NO.	DESCRIPTION
	U	N	A	F		
A				1	105K248400	Front Panel Assembly(Bronze)
A1	1	1	1		105K248410	Front Panel Assembly(Gold)
001B				1	105K248510	Front Panel (K)
001B	1	1	1		105K248600	Front Panel (K)
010B	1	1	1	1	105K270060	Button, Eject
015B	1	1	1	1	105K270040	Button, Function
016B	1	1	1	1	105K355010	Lens, Pause Indicator
017B	1	1	1	1	105K115080	Spring, Function

REF. DESIG.	Q'TY				PART NO.	DESCRIPTION
	U	N	A	F		
005B	1	1	1	1	51500306B0	F.H. Tapped Screw F3 x 6
006B	3	3	3	3	51280306B0	B.H. Tapped Screw B3 x 6
018B	6	6	6	6	51280306B0	B.H. Tapped Screw B3 x 6
019B	3	3	3	3	105K101010	Support
020B	3	3	3	3	3896101010	Support
021B	2	2	2	2	51260308B0	B.T. Screw B3 x 8
025B	1	1	1	1	105K118030	Spacer
026B	1	1	1	1	105K303010	Mask
030B	1	1	1	1	51280306B0	B.H. Tapped Screw B3 x 6
0157				1	21168610A0	Label, Marantz
W503	1	1	1	1	YB00230100	Connective Cord, 8P

[C02-99] LID (Top/Bottom) & PACKING MATERIALS

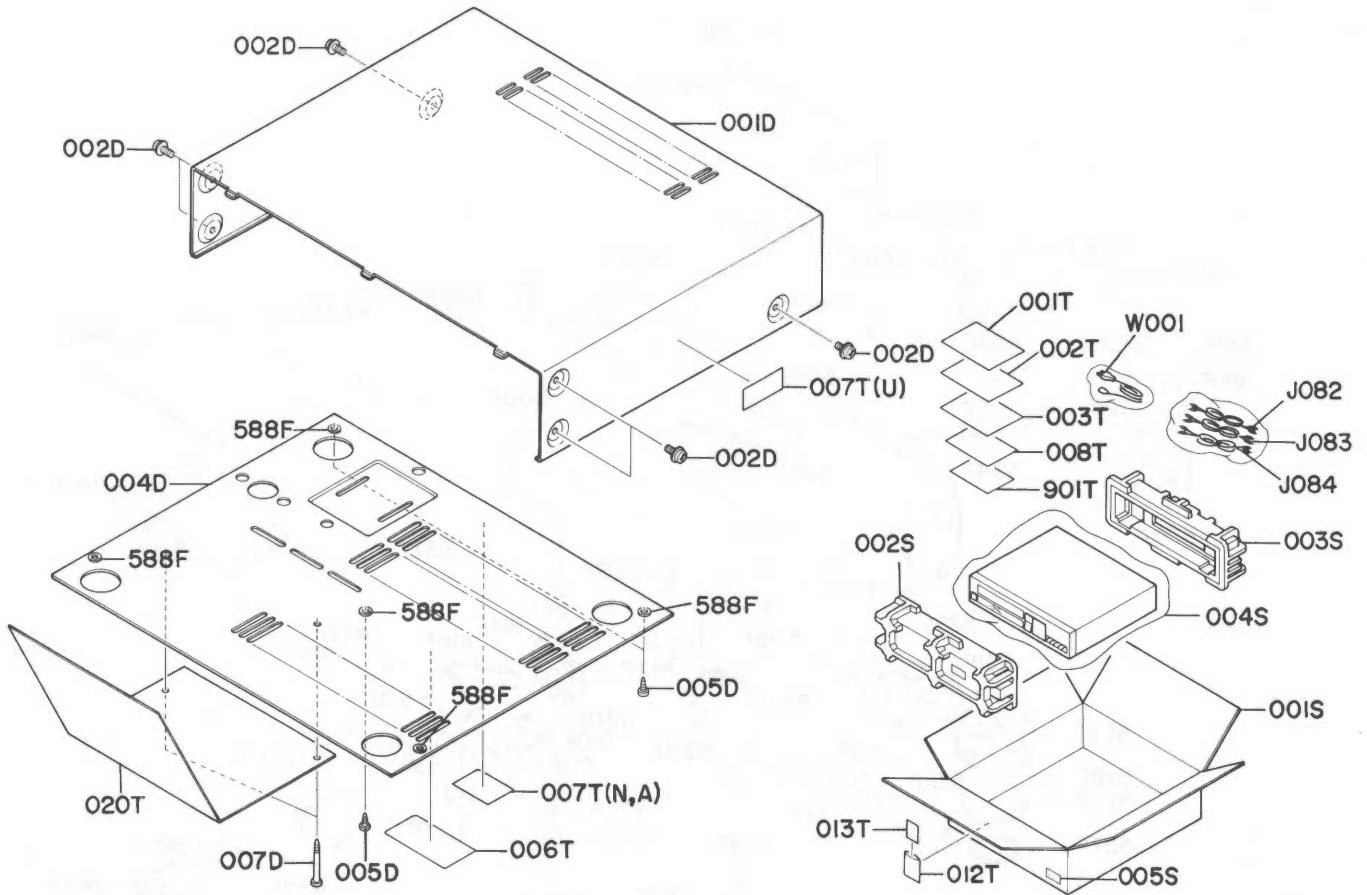

REF. DESIG.	Q'TY				PART NO.	DESCRIPTION
	U	N	A	F		
001D	1	1	1		105K257060	Lid, Top Cover
001D				1	105K257020	Lid, Top Cover
002D	6	6	6	6	51260308Z0	B.T. Screw B3 x 8
004D	1			1	105K257050	Lid, Bottom
004D		1	1		105K257030	Lid, Bottom
005D	3	3	3	3	51280306M0	B.H. Tapped Screw B3 x 6
007D	2	2	2	2	51400350Y0	B.H. Tapped Screw (RED)
588F	5	5	5	5	105K118050	Spacer
006T	1				235H861010	Label, Bottom Cover
007T	1				117H861010	Label, Top Cover
007T		1	1		2911861110	Label, Bottom Cover
020T	1				101K861060	Label, Transportation
020T		1	1		101K861050	Label, Transportation
020T				1	101K861040	Label, Transportation

REF. DESIG.	Q'TY				PART NO.	DESCRIPTION
	U	N	A	F		
001S	1				105K801020	PACKING Packing, Case
001S		1	1	1	105K801010	Packing, Case
002S	1	1	1	1	105K809010	Cushion, Front
003S	1	1	1	1	105K809020	Cushion, Rear
004S	1	1	1	1	9090808030	Polyethylene Sheet
005S				2	9526019010	Serial No. Card
005S				4	9526019060	Serial No. Card
005S				4	9526019030	Serial No. Card
005S				4	9526019040	Serial No. Card
001T	1				105K851210	User Manual
001T		1	1		105K851310	User Manual
001T				1	105K851110	User Manual
002T	1				105K851220	User Manual, Spec
002T		1	1		105K851320	User Manual, Spec
002T				1	9631000130	Warranty Card
003T	1				103H854010	Warranty Card
003T		1			105K856010	Circuit Diagram
003T				1	9631000090	Warranty Card
003T				1	128T854010	Warranty Card
008T	1				9560000100	Hang Tag
012T				1	9611000050	User's Card
013T				1	9540000010	License
901T	1				9650000050	S. Station Card
J082	1	1	1	1	ZD01000170	Connective Cord, Audio Out
J083	1	1	1	1	ZD01000220	Connective Cord, Easy Out
J084	1	1	1	1	ZD01000250	Connective Cord, Remote
AW001				1	ZC01805010	A.C. Power Cord
AW001				1	ZC02006020	A.C. Power Cord

[P01-99] CHASSIS ASSEMBLY

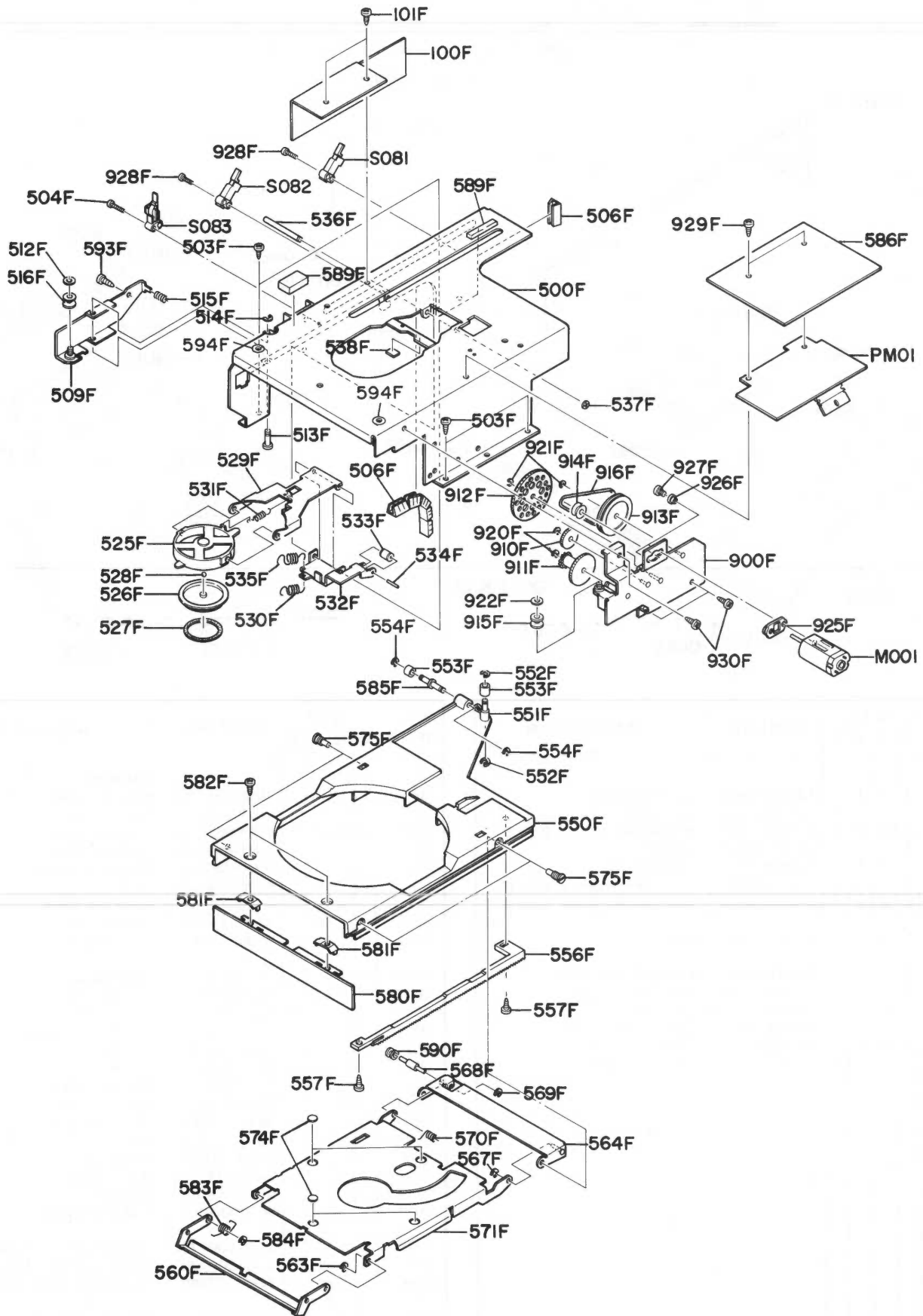

REF. DESIG.	Q'TY				PART NO.	DESCRIPTION
	U	N	A	F		
100F	1				105K120050	Insulator, Limit Sw.
101F	2				51280304B0	B.H. Tapped Screw B3 x 4
500F	1	1	1	1	105K105500	Chassis (K)
503F	4	4	4	4	51280306M0	B.H. Tapped Screw B3 x 6
504F	1	1	1	1	51100210A0	B.H.M. Screw B2 x 10
505F	1	1	1	1	105K259020	Bushing
506F	1	1	1	1	2207259010	Bushing
509F	1	1	1	1	105K160510	Bracket (K), Roller
512F	1	1	1	1	105K118020	Spacer
513F	1	1	1	1	105K112080	Shaft
514F	1	1	1	1	105K118020	Spacer
515F	1	1	1	1	105K115020	Spring
516F	1	1	1	1	105K358010	Roller
525F	1	1	1	1	105K064010	Case, Clamper
526F	1	1	1	1	105K005010	Clamper, Disc
527F	1	1	1	1	105K056020	Buffer
528F	1	1	1	1	61030010T0	Ball
529F	1	1	1	1	105K354010	Lever, Clamper
530F	1	1	1	1	105K115040	Spring, Lift Up
531F	1	1	1	1	105K115060	Spring, Holding
532F	1	1	1	1	105K354030	Lever, Transmit
533F	1	1	1	1	105K358030	Roller, Clamper
534F	1	1	1	1	4367112100	Shaft, Roller
535F	1	1	1	1	105K115050	Spring, Over Stroke
536F	1	1	1	1	105K112070	Shaft, Lever
537F	1	1	1	1	64000200R0	RG Ring, E Type
538F	1	1	1	1	105K056030	Buffer
550F	1	1	1	1	105K163010	Tray
551F	1	1	1	1	105K112040	Shaft, Roller
552F	2	2	2	2	64000200R0	RG Ring, E Type
553F	2	2	2	2	105K358020	Roller
554F	2	2	2	2	64000200R0	RG Ring, E Type
556F	1	1	1	1	105K058010	Gear, Ruck
557F	2	2	2	2	51280306B0	B.H. Tapped Screw B3 x 6
560F	1	1	1	1	105K354510	Lever (K), Front
563F	1	1	1	1	64000200R0	RG Ring, E Type
564F	1	1	1	1	105K354500	Lever (K), Rear
567F	1	1	1	1	64000200R0	RG Ring, E Type
568F	1	1	1	1	105K112050	Shaft, Guide
569F	1	1	1	1	64000200R0	RG Ring, E Type
570F	1	1	1	1	105K115030	Spring, U/D
571F	1	1	1	1	105K163500	Tray (K), U/D
574F	4	4	4	4	105K056010	Buffer
575F	4	4	4	4	105K112020	Shaft
580F	1	1	1	1	105K248030	Front Panel, Tray (GOLD)
580F				1	105K248010	Front Panel, Tray (BRONZE)
581F	2	2	2	2	105K116010	Spring, Leaf
582F	2	2	2	2	51280308U0	B.H. Tapped Screw B3 x 8
583F	1	1	1	1	105K115100	Spring, U/D
584F	1	1	1	1	64002500R0	RG Ring, E Type
585F	1	1	1	1	105K112100	Shaft, Roller
586F	1	1	1	1	105K120030	Insulator
589F	2	2	2	2	105K118060	Spacer
590F	1	1	1	1	105K358040	Roller, Guide
593F	1	1	1	1	51280312B0	B.H. Tapped Screw B3 x 12
594F	2	2	2	2	105K118050	Spacer

REF. DESIG.	Q'TY				PART NO.	DESCRIPTION
	U	N	A	F		
900F	1	1	1	1	105K160520	Bracket (K), Motor
910F	1	1	1	1	105K058020	Gear, Idler
911F	1	1	1	1	105K058030	Gear, Drive
912F	1	1	1	1	101K058010	Gear, Middle
913F	1	1	1	1	101K262010	Pulley, Middle
914F	1	1	1	1	101K262020	Pulley, Motor
915F	1	1	1	1	105K358010	Roller (R)
916F	1	1	1	1	101K264010	Belt, Drive
920F	2	2	2	2	64000200R0	RG Ring, E Type
921F	2	2	2	2	64001500R0	RG Ring, E Type
922F	1	1	1	1	105K118020	Spacer
925F	1	1	1	1	105K259010	Bushing, Motor
926F	2	2	2	2	105K055010	Collar, Motor
927F	2	2	2	2	51100208A0	B.H.M. Screw B2 x 8
928F	1	1	1	1	51100208A0	B.H.M. Screw B2 x 8
929F	2	2	2	2	51280306Z0	B.H. Tapped Screw B3 x 6
930F	3	3	3	3	51280306B0	B.H. Tapped Screw B3 x 6
M001	1	1	1	1	MM0090030	D.C. Motor, Drive
S081	1	1	1	1	SM01020460	Mini Switch, Door 1
S082	1				SM01020470	Mini Switch, Door 2
S083	1	1	1	1	SM01020460	Mini Switch, Tray Out End

[P02-99] FRAME & GENERAL PARTS

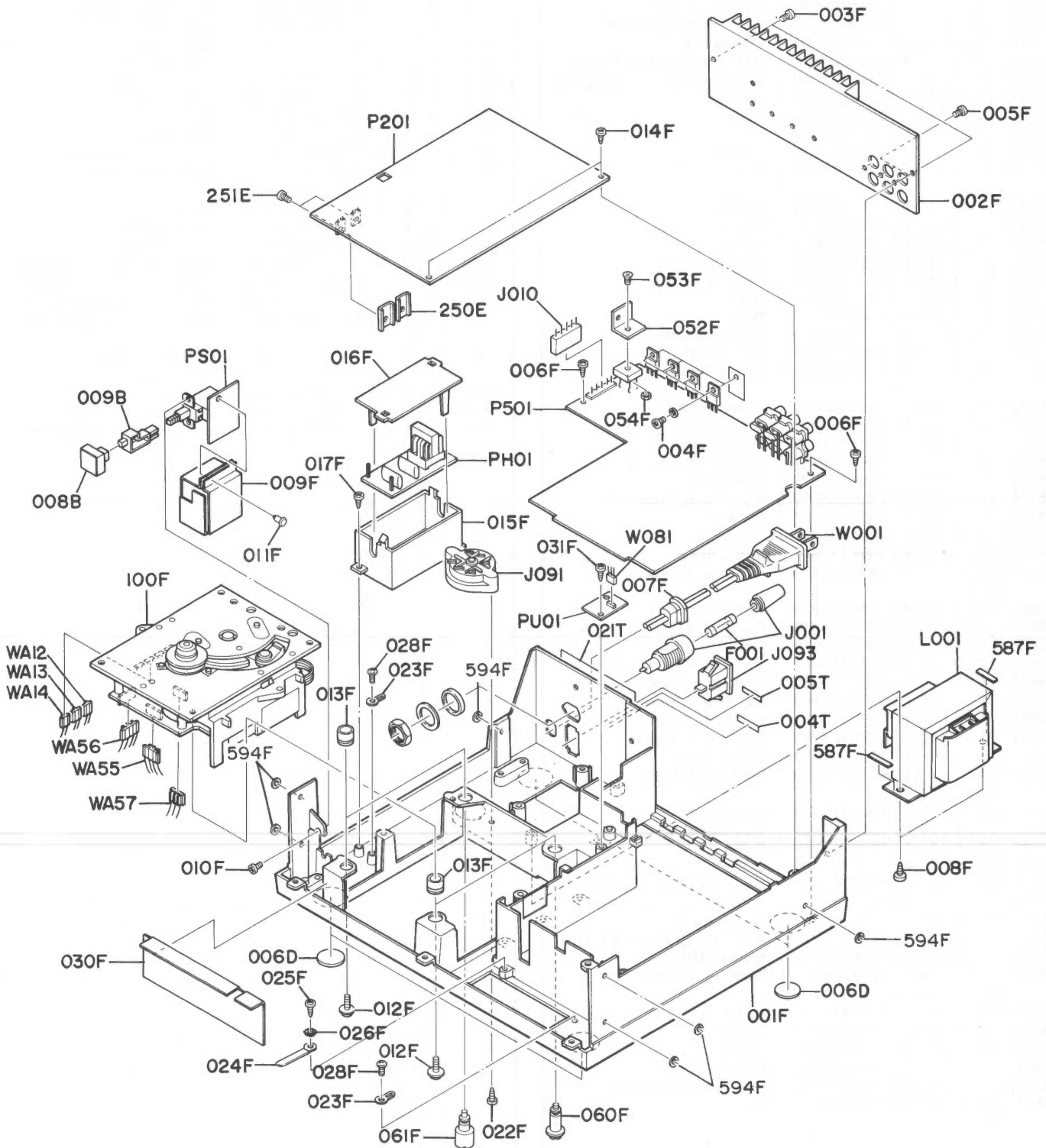

REF. DESIG.	Q'TY				PART NO.	DESCRIPTION
	U	N	A	F		
008B	1	1	1	1	105K270020	Button, Power
009B	1	1	1	1	105K125010	Joint, Power Switch
006D	4	4	4	4	150K057010	Leg
250E	2	2	2	2	415H267010	Heatsink
251E	2	2	2	2	51280306B0	B.H. Tapped Screw B3 x 6
001F	1				105K401020	Frame
001F		1	1		105K401030	Frame
001F				1	105K401010	Frame
002F	1				105K267020	Heatsink
002F		1	1		105K267030	Heatsink
002F				1	105K267010	Heatsink
003F	2	2	2	2	51280306B0	B.H. Tapped Screw B3 x 6
004F	4	4	4	4	51280306M0	B.H. Tapped Screw B3 x 6
005F	3	3	3	3	51280308Z0	B.H. Tapped Screw B3 x 8
006F	3	3	3	3	51280306M0	B.H. Tapped Screw B3 x 8
007F	1			1	1455259090	Bushing, AC Cord
008F	2	2	2	2	51100408M9	B.H.M. Screw B4 x 8
009F		1	1		105K120010	Insulator
010F	1	1	1	1	51100306Z9	B.H.M. Screw B3 x 6
011F	1	1	1	1	2276005050	Clamper
012F	2	2	2	2	101K112190	Shaft
013F	4				101K259120	Bushing
013F		4	4	4	101K259050	Bushing
014F	2	2	2	2	51280306M0	B.H. Tapped Screw B3 x 6
015F	1	1	1		105K064020	Case, Filter
016F	1	1	1		105K257040	Lid, Filter Case
017F	1	1	1		51280306Z0	B.H. Tapped Screw B3 x 6
022F		2	2		51280306Z0	B.H. Tapped Screw B3 x 6
023F	2	2	2	2	62030049W0	Lug, Earth
024F	1	1	1	1	4220005030	Clamper
025F	1	1	1	1	51280306Z0	B.H. Tapped Screw B3 x 6
026F	1	1	1	1	54050300R0	T.L. Washer, OR
027F	1	1	1		51280306Z0	B.H. Tapped Screw B3 x 6
028F	2	2	2	2	51280306Z0	B.H. Tapped Screw B3 x 6
030F	1	1	1	1	105K120020	Insulator, Display
031F	1	1	1	1	51280306Z0	B.H. Tapped Screw B3 x 6
052F	1	1	1	1	4618267210	Heatsink
053F	1	1	1	1	51042612A0	F.H.M. Screw F2.6 x 12
054F	1	1	1	1	53112603A0	Hexagon Nut M2.6
060F	1	1	1	1	105K112150	Shaft
061F	1	1	1	1	105K112160	Shaft
100F	1	1	1	1	109K165020	Turntable Assembly
587F	2	2	2	2	105F118040	Spacer
594F	6	6	6	6	105K118050	Spacer
004T	1	1	1	1	2112265010	Indicator, Serial No.
005T		1	1		4581861010	Label, Made in Japan
021T	1				105K861030	Label
021T		1	1		105K861020	Label
021T				1	105K861010	Label

REF. DESIG.	Q'TY				PART NO.	DESCRIPTION
	U	N	A	F		
△F001	1				FS10150500	Fuse, 1.5A 250V
△F001		1	1		FS10025800	Fuse, 250mA 250V
△J001	1				YJ08000300	Jack, Fuse Holder
△J001		1	1		YJ08000290	Jack, Fuse Holder
J010	1	1	1	1	YJ06001050	Jack, 5P
△J091		1	1		BY05080050	Voltage Selector
△J093		1	1		YP04000580	Plug, AC Inlet
△L001	1				TS16642030	Power Transformer
△L001		1	1		TS16642020	Power Transformer
△L001				1	TS16642010	Power Transformer
△W001	1				YC02000160	A.C. Power Cord
△W001				1	YC01800200	A.C. Power Cord
W081	1	1	1	1	YB00350180	Connective Cord, 2P
WA12	1	1	1	1	YB00309030	Connective Cord, 2P
WA13	1	1	1	1	YB00309040	Connective Cord, 2P
WA14	1	1	1	1	YB00309050	Connective Cord, 2P
WA55	1	1	1	1	YB00309010	Connective Cord, 3P
WA56	1	1	1	1	YB00409010	Connective Cord, 4P
WA57	1	1	1	1	YB00329010	Connective Cord, 4P

(U): for U.S.A.
 (N): for Europe
 (A): for Australia
 (F): for Japan

8. ELECTRICAL PARTS LIST

REF. DESIG.	Q'TY				PART NO.	DESCRIPTION
	U	N	A	F		
P101	1	1	1	1	WC108K0410 ZZ108K0410	P101-HF-AMP CIRCUIT BOARD P.W. Board, HF-Amp P.W. Board Assembly
P101-CAPACITORS						
C101	1	1	1	1	DK46681300	Ceramic 680pF ±10%,Chip
C102	1	1	1	1	DK46681300	Ceramic 680pF ±10%,Chip
C103	1	1	1	1	DK46681300	Ceramic 680pF ±10%,Chip
C104	1	1	1	1	DK46681300	Ceramic 680pF ±10%,Chip
C110	1	1	1	1	DK46103300	Ceramic 0.01μF ±10%,Chip
C111	1	1	1	1	DK46103300	Ceramic 0.01μF ±10%,Chip
C115	1	1	1	1	DK46103300	Ceramic 0.01μF ±10%,Chip
C117	1	1	1	1	DK45470300	Ceramic 47pF ±5%, Chip
C122	1	1	1	1	DD45181300	Ceramic 180pF ±5%, Chip
C127	1	1	1	1	DD45820300	Ceramic 82pF ±5%, Chip
C129	1	1	1	1	DK46103300	Ceramic 0.01μF ±10%,Chip
C132	1	1	1	1	DD45680300	Ceramic 68pF ±5%, Chip
C133	1	1	1	1	DD45220300	Ceramic 22pF ±5%, Chip
C135	1	1	1	1	DK46103300	Ceramic 0.01μF ±10%,Chip
C136	1	1	1	1	DK46103300	Ceramic 0.01μF ±10%,Chip
C140	1	1	1	1	OA33601630	Elect 33μF 16V
C141	1	1	1	1	DK46103300	Ceramic 0.01μF ±10%,Chip
C142	1	1	1	1	DK46103300	Ceramic 0.01μF ±10%,Chip
C143	1	1	1	1	OA33601630	Elect 33μF 16V
C144	1	1	1	1	OA33601630	Elect 33μF 16V
C145	1	1	1	1	DK46103300	Ceramic 0.01μF ±10%,Chip
C147	1	1	1	1	OA33601630	Elect 33μF 16V
C148	1	1	1	1	DK46103300	Ceramic 0.01μF ±10%,Chip
C149	1	1	1	1	OA33601630	Elect 33μF 16V
P101-RESISTORS (All Resistors are ±5% & 1/8W)						
R101	1	1	1	1	RI05223180	22KΩ, Chip
R102	1	1	1	1	RI05223180	22KΩ, Chip
R103	1	1	1	1	RI05223180	22KΩ, Chip
R104	1	1	1	1	RI05223180	22KΩ, Chip
R110	1	1	1	1	RI05222180	2.2KΩ, Chip
R111	1	1	1	1	RI05222180	2.2KΩ, Chip
R112	1	1	1	1	RI05470180	47Ω, Chip
R113	1	1	1	1	RI05103180	10KΩ, Chip
R115	1	1	1	1	RI05684180	680KΩ, Chip
R116	1	1	1	1	RI05684180	680KΩ, Chip
R118	1	1	1	1	RI05684180	680KΩ, Chip
R119	1	1	1	1	RI05684180	680KΩ, Chip
R123	1	1	1	1	RI05223180	22KΩ, Chip
R124	1	1	1	1	RI05223180	22KΩ, Chip
R125	1	1	1	1	RI05103180	10KΩ, Chip
R130	1	1	1	1	RI05222180	2.2KΩ, Chip
R131	1	1	1	1	RI05222180	2.2KΩ, Chip
R132	1	1	1	1	RI05222180	2.2KΩ, Chip
R133	1	1	1	1	RI05222180	2.2KΩ, Chip
R137	1	1	1	1	RI05103180	10KΩ, Chip
R138	1	1	1	1	RI05103180	10KΩ, Chip
R139	1	1	1	1	RI05103180	10KΩ, Chip
R140	1	1	1	1	RI05103180	10KΩ, Chip
R141	1	1	1	1	RA04730600	47KΩ, Trimming
R145	1	1	1	1	RI05391180	390Ω, Chip
R146	1	1	1	1	RI05470180	47Ω, Chip
R148	1	1	1	1	RI05682180	6.8KΩ, Chip
R150	1	1	1	1	RI05222180	2.2KΩ, Chip
R152	1	1	1	1	RI05153180	15KΩ, Chip
R153	1	1	1	1	RI05271180	270Ω, Chip

REF. DESIG.	Q'TY				PART NO.	DESCRIPTION
	U	N	A	F		
R155	1	1	1	1	RI05223180	22KΩ, Chip
R156	1	1	1	1	RI05223180	22KΩ, Chip
R158	1	1	1	1	RA02220600	2.2KΩ, Trimming
R162	1	1	1	1	RI05332180	3.3KΩ, Chip
R163	1	1	1	1	RI05182180	1.8KΩ, Chip
R164	1	1	1	1	RI05332180	3.3KΩ, Chip
R165	1	1	1	1	RI05682180	6.8KΩ, Chip
R166	1	1	1	1	RI05470180	47Ω, Chip
R167	1	1	1	1	RI05332180	3.3KΩ, Chip
R172	1	1	1	1	RI05332180	3.3KΩ, Chip
R173	1	1	1	1	RI05222180	2.2KΩ, Chip
R174	1	1	1	1	RI05222180	2.2KΩ, Chip
R175	1	1	1	1	RI05222180	2.2KΩ, Chip
R176	1	1	1	1	RI05470180	47Ω, Chip
R177	1	1	1	1	RI05682180	6.8KΩ, Chip
R179	1	1	1	1	RI05124180	120KΩ, Chip
R180	1	1	1	1	RA01020600	1KΩ, Trimming
R181	1	1	1	1	RI05470180	47Ω, Chip
R182	1	1	1	1	RI05123180	12KΩ, Chip
R184	1	1	1	1	RI05105180	1MΩ, Chip
R186	1	1	1	1	RI05271180	270Ω, Chip
R187	1	1	1	1	RI05682180	6.8KΩ, Chip
R188	1	1	1	1	RI05124180	120KΩ, Chip
R189	1	1	1	1	RI05332180	3.3KΩ, Chip
R190	1	1	1	1	RI05151180	150Ω, Chip
R191	1	1	1	1	RI05124180	120KΩ, Chip
R192	1	1	1	1	RI05181180	180Ω, Chip
R194	1	1	1	1	NF02150140	15Ω ±2% ¼W,Fuse
R195	1	1	1	1	RI05105140	1MΩ, Chip
R196	1	1	1	1	RI05181180	180Ω, Chip
R197	1	1	1	1	NF02470140	47Ω ±2% ¼W,Fuse
R198	1	1	1	1	RI05332180	3.3KΩ, Chip
R199	1	1	1	1	RI05181180	180Ω, Chip
P101-SEMICONDUCTORS						
Q101	1	1	1	1	HC10031090	IC NJM2058D
Q103	1	1	1	1	HT327852E0	Transistor 2SC2785(EF,KF)
Q104	1	1	1	1	HT327852E0	Transistor 2SC2785(EF,KF)
Q105	1	1	1	1	HT327852E0	Transistor 2SC2785(EF,KF)
Q107	1	1	1	1	HC10083060	IC UA741C
Q109	1	1	1	1	HT327852E0	Transistor 2SC2785(EF,KF)
Q110	1	1	1	1	HT327852E0	Transistor 2SC2785(EF,KF)
Q111	1	1	1	1	HT327852E0	Transistor 2SC2785(EF,KF)
Q114	1	1	1	1	HC10030090	IC NJM2904D
Q118	1	1	1	1	HT313832C0	Transistor 2SC1383(R, S)
P101-MISCELLANEOUS						
J060	1	1	1	1	YJ07001210	Jack, 8P
J070	1	1	1	1	YJ07001200	Jack, 6P
J150	1	1	1	1	YJ06003020	Jack, 2P
J160	1	1	1	1	YP10002010	Plug, 5P
J170	1	1	1	1	YP10002070	Plug, 11P
J180	1	1	1	1	YJ06003020	Jack, 2P
M042	1	1	1	1	MM00500030	D.C. Motor
P061-PHOTO DIODE FLEX. CIRCUIT BOARD						
P061	1	1	1	1	WE108K0120 ZZ108K0120	P.W. Board, Photo Diode Flex. P.W. Board Assembly
D061	1	1	1	1	HI60001490	L.E.D., Detect
P071	1	1	1	1	WE108K0110	P.W. Board, Laser Diode Flex.

REF. DESIG.	Q'TY				PART NO.	DESCRIPTION
	U	N	A	F		
P702	1	1	1	1	YF108K0010 ZZ108K0010	P702-LASER DIODE CIRCUIT BOARD P.W. Board, Laser Diode P.W. Board Assembly
D071	1	1	1	1	HI20002320	L.E.D., Laser
L071	1	1	1	1	LD00004010	Coil Assy, Radial
L072	1	1	1	1	LD00004010	Coil Assy, Radial
L073	1	1	1	1	LD00011010	Coil Assy, Focus
P201	1	1	1	1	WB105K1520 ZZ105K1520	P201-SERVO CIRCUIT BOARD P.W. Board, Servo P.W. Board Assembly
C201	1	1	1	1	DK46103300	Ceramic 0.01 μ F \pm 10%,Chip
C203	1	1	1	1	DK46103300	Ceramic 0.01 μ F \pm 10%,Chip
C204	1	1	1	1	DF15104350	Film 0.1 μ F \pm 5%
C205	1	1	1	1	DF15273350	Film 0.027 μ F \pm 5%
C207	1	1	1	1	OA33601610	Elect 33 μ F 16V
C208	1	1	1	1	DK46103300	Ceramic 0.01 μ F \pm 10%,Chip
C209	1	1	1	1	OA10505010	Elect 1 μ F 50V
C210	1	1	1	1	DD45680300	Ceramic 68pF \pm 5%, Chip
C211	1	1	1	1	DF15104350	Film 0.1 μ F \pm 5%
C212	1	1	1	1	DK46331300	Ceramic 330pF \pm 10%,Chip
C213	1	1	1	1	DD45680300	Ceramic 68pF \pm 5%, Chip
C214	1	1	1	1	EQ22601630	Elect 22 μ F 16V
C215	1	1	1	1	DF15154350	Film 0.15 μ F \pm 5%
C216	1	1	1	1	DF15103350	Film 0.01 μ F \pm 5%
C217	1	1	1	1	OA33505010	Elect 3.3 μ F 50V
C218	1	1	1	1	DF15153350	Film 0.015 μ F \pm 5%
C219	1	1	1	1	DF15473350	Film 0.047 μ F \pm 5%
C228	1	1	1	1	DF15104350	Film 0.1 μ F \pm 5%
C233	1	1	1	1	DF15474350	Film 0.47 μ F \pm 5%
C235	1	1	1	1	DK46103300	Ceramic 0.01 μ F \pm 10%,Chip
C236	1	1	1	1	DF15562350	Film 5600pF \pm 5%
C237	1	1	1	1	DF15333350	Film 0.033 μ F \pm 5%
C238	1	1	1	1	DF15562350	Film 5600pF \pm 5%
C239	1	1	1	1	DF74391030	Film 390pF \pm 2%
C241	1	1	1	1	OA33601610	Elect 33 μ F 16V
C242	1	1	1	1	OA33601610	Elect 33 μ F 16V
C243	1	1	1	1	DF15474350	Film 0.47 μ F \pm 5%
C244	1	1	1	1	DF74681030	Film 680pF \pm 2%
C246	1	1	1	1	DF74682010	Film 6800pF \pm 2%
C247	1	1	1	1	DF74682010	Film 6800pF \pm 2%
C250	1	1	1	1	OA33601610	Elect 33 μ F 16V
C251	1	1	1	1	DF15224350	Film 0.22 μ F \pm 5%
C256	1	1	1	1	DF15182350	Film 1800pF \pm 5%
C257	1	1	1	1	DF15682350	Film 6800pF \pm 5%
C259	1	1	1	1	DF15223350	Film 0.022 μ F \pm 5%
C261	1	1	1	1	DF74682010	Film 6800pF \pm 2%
C262	1	1	1	1	DF74682010	Film 6800pF \pm 2%
C265	1	1	1	1	OA33701610	Elect 330 μ F 16V
C266	1	1	1	1	OA33701610	Elect 330 μ F 16V
C267	1	1	1	1	EQ10505030	Elect 1 μ F 50V
C280	1	1	1	1	DF15104350	Film 0.1 μ F \pm 5%
C281	1	1	1	1	DK46223200	Ceramic 0.22 μ F \pm 10%,Chip
C282	1	1	1	1	DK46223200	Ceramic 0.22 μ F \pm 10%,Chip

REF. DESIG.	Q'TY				PART NO.	DESCRIPTION
	U	N	A	F		
R201	1	1	1	1	RI05473180	P201-RESISTORS (All Resistors are \pm 5% & 1/8W) 47K Ω , Chip
R202	1	1	1	1	RI05105180	1M Ω , Chip
R203	1	1	1	1	GD05824140	820K Ω $\frac{1}{4}$ W
R204	1	1	1	1	RI05105180	1M Ω , Chip
R205	1	1	1	1	RI05104180	100K Ω , Chip
R206	1	1	1	1	RI05474180	470K Ω , Chip
R209	1	1	1	1	RI05473180	47K Ω , Chip
R210	1	1	1	1	GD05104140	100K Ω $\frac{1}{4}$ W
R211	1	1	1	1	RI05472180	4.7K Ω , Chip
R212	1	1	1	1	RI05472180	4.7K Ω , Chip
R214	1	1	1	1	RI05223180	22K Ω , Chip
R215	1	1	1	1	GD05682140	6.8K Ω $\frac{1}{4}$ W
R216	1	1	1	1	GD05104140	100K Ω $\frac{1}{4}$ W
R217	1	1	1	1	RI05333180	33K Ω , Chip
R219	1	1	1	1	RI05222180	2.2K Ω , Chip
R220	1	1	1	1	RI05223180	22K Ω , Chip
R221	1	1	1	1	RI05682180	6.8K Ω , Chip
R222	1	1	1	1	RI05123180	12K Ω , Chip
R223	1	1	1	1	RI05104180	100K Ω , Chip
R224	1	1	1	1	GD05473140	47K Ω $\frac{1}{4}$ W
R225	1	1	1	1	RI05332180	3.3K Ω , Chip
R226	1	1	1	1	RI05471180	470 Ω , Chip
R227	1	1	1	1	BW05472020	4.7K Ω , Compo.
R228	1	1	1	1	RI05472180	4.7K Ω , Chip
R229	1	1	1	1	RI05472180	4.7K Ω , Chip
R230	1	1	1	1	RI05563180	56K Ω , Chip
R231	1	1	1	1	RI05334180	330K Ω , Chip
R233	1	1	1	1	RI05104180	100K Ω , Chip
R234	1	1	1	1	RI05472180	4.7K Ω , Chip
R235	1	1	1	1	RI05472180	4.7K Ω , Chip
R238	1	1	1	1	RI05474180	470K Ω , Chip
R239	1	1	1	1	RI05473180	47K Ω , Chip
R240	1	1	1	1	GD05033140	3.3 Ω $\frac{1}{4}$ W
R242	1	1	1	1	RI05565180	5.6M Ω , Chip
R243	1	1	1	1	RI05565180	5.6M Ω , Chip
R244	1	1	1	1	RI05472180	4.7K Ω , Chip
R245	1	1	1	1	RI05154180	150K Ω , Chip
R246	1	1	1	1	RI05101180	100 Ω , Chip
R247	1	1	1	1	RI05102180	1K Ω , Chip
R250	1	1	1	1	RI05683180	68K Ω , Chip
R251	1	1	1	1	RI05683180	68K Ω , Chip
R252	1	1	1	1	RI05681180	680 Ω , Chip
R253	1	1	1	1	RI05472180	4.7K Ω , Chip
R254	1	1	1	1	RI05104180	100K Ω , Chip
R255	1	1	1	1	RI05223180	22K Ω , Chip
R256	1	1	1	1	GA05033020	3.3 Ω 2W
R257	1	1	1	1	RI05273180	27K Ω , Chip
R258	1	1	1	1	RI05272180	2.7K Ω , Chip
R259	1	1	1	1	RI05682180	6.8K Ω , Chip
R260	1	1	1	1	RI05563180	56K Ω , Chip

REF. DESIG.	Q'TY				PART NO.	DESCRIPTION
	U	N	A	F		
R261	1	1	1	1	RI05563180	56K Ω , Chip
R262	1	1	1	1	RI05332180	3.3K Ω , Chip
R264	1	1	1	1	RI05332180	3.3K Ω , Chip
R276	1	1	1	1	RI05472180	4.7K Ω , Chip
R279	1	1	1	1	RI01473180	47K Ω , Chip $\pm 0.5\text{pF}$
R280	1	1	1	1	RI01473180	47K Ω , Chip $\pm 0.5\text{pF}$
R281	1	1	1	1	RI05474180	470K Ω , Chip
R282	1	1	1	1	RI05473180	47K Ω , Chip
R283	1	1	1	1	RI05473180	47K Ω , Chip
R284	1	1	1	1	GD05103140	10K Ω $\frac{1}{4}\text{W}$
R287	1	1	1	1	RI01682180	6.8K Ω , Chip $\pm 0.5\text{pF}$
R288	1	1	1	1	RI01682180	6.8K Ω , Chip $\pm 0.5\text{pF}$
R291	1	1	1	1	GD05473140	47K Ω $\frac{1}{4}\text{W}$
R292	1	1	1	1	GD05473140	47K Ω $\frac{1}{4}\text{W}$
R293	1	1	1	1	RI05471180	470 Ω , Chip
R294	1	1	1	1	RI05471180	470 Ω , Chip
R298	1	1	1	1	RI05471180	470 Ω , Chip
R299	1	1	1	1	RI05272180	2.7K Ω , Chip
R300	1	1	1	1	RI05103180	10K Ω , Chip
R301	1	1	1	1	RI05103180	10K Ω , Chip
R302	1	1	1	1	RI05222180	2.2K Ω , Chip
R304	1	1	1	1	RI05103180	10K Ω , Chip
R305	1	1	1	1	RI05103180	10K Ω , Chip
R306	1	1	1	1	RI05272180	2.7K Ω , Chip
R307	1	1	1	1	RI05222180	2.2K Ω , Chip
R308	1	1	1	1	RI05471180	470 Ω , Chip
R311	1	1	1	1	RI01823180	82K Ω , Chip $\pm 0.5\text{pF}$
R312	1	1	1	1	RI01823180	82K Ω , Chip $\pm 0.5\text{pF}$
R313	1	1	1	1	RI05472180	4.7K Ω , Chip
R315	1	1	1	1	RA01030630	10K Ω , Trimming
R316	1	1	1	1	RI05473180	47K Ω , Chip
R318	1	1	1	1	RI05821180	820 Ω , Chip
R319	1	1	1	1	RI05471180	470 Ω , Chip
R320	1	1	1	1	GD05152140	1.5K Ω $\frac{1}{4}\text{W}$
R323	1	1	1	1	RI05124180	120K Ω , Chip
R324	1	1	1	1	RI05473180	75K Ω , Chip
R325	1	1	1	1	RI05473180	75K Ω , Chip
R326	1	1	1	1	RI05224180	220K Ω , Chip
R327	1	1	1	1	RI05104180	100K Ω , Chip
R328	1	1	1	1	GD05334140	330K Ω $\frac{1}{4}\text{W}$
R335	1	1	1	1	RI05683180	68K Ω , Chip
R336	1	1	1	1	RI05472180	4.7K Ω , Chip
R340	1	1	1	1	RI05103180	10K Ω , Chip
R341	1	1	1	1	RI05103180	10K Ω , Chip
R342	1	1	1	1	RI05563180	56K Ω , Chip
R345	1	1	1	1	RI05473180	47K Ω , Chip
R346	1	1	1	1	RI05473180	47K Ω , Chip
R349	1	1	1	1	RI05183180	18K Ω , Chip
R350	1	1	1	1	RI05184180	180K Ω , Chip
R351	1	1	1	1	RI05333180	33K Ω , Chip
R352	1	1	1	1	RI05273180	27K Ω , Chip
R353	1	1	1	1	RI05472180	4.7K Ω , Chip
R356	1	1	1	1	RI05363180	36K Ω , Chip
R357	1	1	1	1	RI05392180	3.9K Ω , Chip
R358	1	1	1	1	RI05364180	360K Ω , Chip
R359	1	1	1	1	RI05272180	2.7K Ω , Chip
R360	1	1	1	1	GD05104140	100K Ω $\frac{1}{4}\text{W}$
R362	1	1	1	1	GD05104140	100K Ω $\frac{1}{4}\text{W}$
R363	1	1	1	1	RI05103180	10K Ω , Chip
R364	1	1	1	1	RI05472180	4.7K Ω , Chip

REF. DESIG.	Q'TY				PART NO.	DESCRIPTION
	U	N	A	F		
R365	1	1	1	1	RI05474180	470K Ω , Chip
R366	1	1	1	1	RI05334180	330K Ω , Chip
R367	1	1	1	1	RI05474180	470K Ω , Chip
R370	1	1	1	1	RI05273180	27K Ω , Chip
R372	1	1	1	1	RI05473180	47K Ω , Chip
R373	1	1	1	1	RI05184180	180K Ω , Chip
R375	1	1	1	1	RI05683180	68K Ω , Chip
R376	1	1	1	1	RI05472180	4.7K Ω , Chip
R378	1	1	1	1	RI05273180	27K Ω , Chip
R379	1	1	1	1	RI05273180	27K Ω , Chip
R380	1	1	1	1	RI05332180	3.3K Ω , Chip
R381	1	1	1	1	RI05121180	120 Ω , Chip
R382	1	1	1	1	RI05121180	120 Ω , Chip
R384	1	1	1	1	GA05082020	8.2 Ω 2W
R385	1	1	1	1	GA05082020	8.2 Ω 2W
R386	1	1	1	1	RI05332180	3.3K Ω , Chip
R387	1	1	1	1	GD05022140	2.2 Ω $\frac{1}{4}\text{W}$
R391	1	1	1	1	RI05562180	5.6K Ω , Chip
R392	1	1	1	1	RI05133180	13K Ω , Chip
R393	1	1	1	1	RI05223180	22K Ω , Chip
R394	1	1	1	1	RI05334180	330K Ω , Chip
R395	1	1	1	1	RI05223180	22K Ω , Chip
R396	1	1	1	1	RI05563180	56K Ω , Chip
R397	1	1	1	1	RI05563180	56K Ω , Chip
R398	1	1	1	1	RI05182180	1.8K Ω , Chip
R399	1	1	1	1	RI05182180	1.8K Ω , Chip
D244	1	1	1	1	HD20001000	Diode 1S2473
D245	1	1	1	1	HD20001000	Diode 1S2473
D246	1	1	1	1	HD20001000	Diode 1S2473
D249	1	1	1	1	HD20001000	Diode 1S2473
D250	1	1	1	1	HD20001000	Diode 1S2473
D251	1	1	1	1	HD30041010	Zener HZ2C2
D252	1	1	1	1	HD30021060	Zener RD5.1EB2
D253	1	1	1	1	HZ30001020	Chip Diode MA3068-M
D255	1	1	1	1	HD20001000	Diode 1S2473
D256	1	1	1	1	HD20001000	Diode 1S2473
D257	1	1	1	1	HD20001000	Diode 1S2473
D258	1	1	1	1	HD20001000	Diode 1S2473
D259	1	1	1	1	HD20001000	Diode 1S2473
Q201	1	1	1	1	HC10094060	IC $\mu\text{PD1512ACU}$
Q205	1	1	1	1	HC10081060	IC μPC339C
Q207	1	1	1	1	HC10055010	IC HD14025N
Q208	1	1	1	1	HC10003090	IC NJM4558D
Q209	1	1	1	1	HC10003090	IC NJM4558D
Q211	1	1	1	1	HC10056010	IC HD14053B
Q212	1	1	1	1	HC10082060	IC μPC324C
Q213	1	1	1	1	HC10057010	IC HD14070B
Q214	1	1	1	1	HC10082060	IC μPC324C
Q215	1	1	1	1	HC10082060	IC μPC324C
Q217	1	1	1	1	HC10003090	IC NJM4558D
Q218	1	1	1	1	HC10083060	IC μPC741C
Q219	1	1	1	1	HC10058010	IC HD74LS74A
Q220	1	1	1	1	HC10058010	IC HD74LS74A
Q230	1	1	1	1	HT309452B0	Transistor 2SC945(P or Q)
Q231	1	1	1	1	HT328241Y0	Transistor 2SC2824(Y)
Q232	1	1	1	1	HT111841Y0	Transistor 2SA1184(Y)
Q233	1	1	1	1	HT313841R0	Transistor 2SC1384(R)
Q234	1	1	1	1	HT106841R0	Transistor 2SA684(R)
Q238	1	1	1	1	HT309452B0	Transistor 2SC945(P or Q)

P201-SEMICONDUCTORS

REF. DESIG.	Q'TY				PART NO.	DESCRIPTION
	U	N	A	F		
Q239	1	1	1	1	HT309452B0	Transistor 2SC945(P or Q)
Q240	1	1	1	1	HT111841Y0	Transistor 2SA1184(Y)
Q241	1	1	1	1	HT328241Y0	Transistor 2SC2824(Y)
Q242	1	1	1	1	HT107332A0	Transistor 2SA733(P or Q)
Q243	1	1	1	1	HT333811G0	Transistor 2SC3381(GR)
Q244	1	1	1	1	HT333811G0	Transistor 2SC3381(GR)
Q245	1	1	1	1	HT309452B0	Transistor 2SC945(P or Q)
Q246	1	1	1	1	HT309452B0	Transistor 2SC945(P or Q)
P201-MISCELLANEOUS						
J201	1	1	1	1	YJ06003110	Jack, 11P
J202	1	1	1	1	YJ06003100	Jack, 10P
J203	1	1	1	1	YJ06003070	Jack, 7P
J204	1	1	1	1	YJ06003060	Jack, 6P
W201	1	1	1	1	YB00290020	Connective Cord, 11P
X201	1	1	1	1	FQ03504010	Seramic Vib. 3.58MHz
P501-DECODER-SUPPLY CIRCUIT BOARD						
P501	1	1	1	1	WB105K1500	P.W. Board, Decoder-Supply
	1	1	1	1	ZZ105K1500	P.W. Board Assembly
P501-CAPACITORS						
C501	1	1	1	1	DF74223030	Film 0.022μF ±2%
C502	1	1	1	1	DF74223030	Film 0.022μF ±2%
C503	1	1	1	1	DK46222300	Ceramic 2000pF ±10%,Chip
C505	1	1	1	1	DK46272300	Ceramic 2700pF ±10%,Chip
C506	1	1	1	1	DK46472300	Ceramic 4700pF ±10%,Chip
C507	1	1	1	1	DK46222300	Ceramic 2200pF ±10%,Chip
C508	1	1	1	1	DK46821300	Ceramic 820pF ±10%,Chip
C511	1	1	1	1	DK46223300	Ceramic 0.022μF ±10%,Chip
C512	1	1	1	1	DK46223300	Ceramic 0.022μF ±10%,Chip
C514	1	1	1	1	DF16104310	Film 0.1μF ±10%
C515	1	1	1	1	DF16104310	Film 0.1μF ±10%
C516	1	1	1	1	DK46103300	Ceramic 0.01μF ±10%,Chip
C520	1	1	1	1	DK46471300	Ceramic 470pF ±10%,Chip
C521	1	1	1	1	DK46471300	Ceramic 470pF ±10%,Chip
C523	1	1	1	1	DK46103300	Ceramic 0.01μF ±10%,Chip
C525	1	1	1	1	DK46222300	Ceramic 2200pF ±10%,Chip
C527	1	1	1	1	DF16104310	Film 0.1μF ±10%
C532	1	1	1	1	DK46223300	Ceramic 0.022μF ±10%,Chip
C533	1	1	1	1	OA10505010	Elect 1μF 50V
C537	1	1	1	1	DK46223300	Ceramic 0.022μF ±10%,Chip
C538	1	1	1	1	DK46223300	Ceramic 0.022μF ±10%,Chip
C539	1	1	1	1	DK46223300	Ceramic 0.022μF ±10%,Chip
C542	1	1	1	1	DD45680300	Ceramic 68pF ±5%, Chip
C543	1	1	1	1	DD45330300	Ceramic 33pF ±5%, Chip
C550	1	1	1	1	DK46223300	Ceramic 0.022μF ±10%,Chip
C555	1	1	1	1	DK46223300	Ceramic 0.022μF ±10%,Chip
C558	1	1	1	1	OA47601610	Elect 47μF 16V
C559	1	1	1	1	DK46223300	Ceramic 0.022μF ±10%,Chip
C560	1	1	1	1	DK46223300	Ceramic 0.022μF ±10%,Chip
C562	1	1	1	1	DK46223300	Ceramic 0.022μF ±10%,Chip
C563	1	1	1	1	OA22700610	Elect 220μF 6.3V
C564	1	1	1	1	DK46821300	Ceramic 820pF ±10%,Chip
C566	1	1	1	1	DF74512030	Film 5100pF ±2%
C567	1	1	1	1	DF74153010	Film 0.015μF ±2%
C568	1	1	1	1	DF74222010	Film 2200pF ±2%

REF. DESIG.	Q'TY				PART NO.	DESCRIPTION
	U	N	A	F		
C570	1	1	1	1	DF74222010	Film 2200pF ±2%
C571	1	1	1	1	DF74222010	Film 1200pF ±2%
C573	1	1	1	1	EA10701660	Elect 100μF 16V
C574	1	1	1	1	EA10701660	Elect 100μF 16V
C575	1	1	1	1	DD45101300	Ceramic 100pF ±5%, Chip
C580	1	1	1	1	DF15474350	Film 0.47μF ±5%
C581	1	1	1	1	DF15474350	Film 0.47μF ±5%
C582	1	1	1	1	DF16104310	Film 0.1μF ±10%
C583	1	1	1	1	DF16104310	Film 0.1μF ±10%
C584	1	1	1	1	DF16104310	Film 0.1μF ±10%
C585	1	1	1	1	DK46223300	Ceramic 0.022μF ±10%,Chip
C586	1	1	1	1	DK46223300	Ceramic 0.022μF ±10%,Chip
C587	1	1	1	1	DK46223300	Ceramic 0.022μF ±10%,Chip
C588	1	1	1	1	DK46223300	Ceramic 0.022μF ±10%,Chip
C589	1	1	1	1	DK46223300	Ceramic 0.022μF ±10%,Chip
C591	1	1	1	1	DK46152300	Ceramic 1500pF ±10%,Chip
C594	1	1	1	1	DK46223300	Ceramic 0.022μF ±10%,Chip
C595	1	1	1	1	DK46223300	Ceramic 0.022μF ±10%,Chip
C597	1	1	1	1	KD46223300	Ceramic 0.022μF ±10%,Chip
C599	1	1	1	1	DK46821300	Ceramic 820pF ±10%,Chip
C601	1	1	1	1	DF74512030	Film 5100pF ±2%
C602	1	1	1	1	DF74153010	Film 0.015μF ±2%
C603	1	1	1	1	DF74222010	Film 2200pF ±2%
C605	1	1	1	1	DF74222010	Film 2200pF ±2%
C606	1	1	1	1	DF74122010	Film 1200pF ±2%
C608	1	1	1	1	EA10701660	Elect 100μF 16V
C609	1	1	1	1	EA10701660	Elect 100μF 16V
C610	1	1	1	1	DD45101300	Ceramic 100pF ±5%, Chip
C615	1	1	1	1	OA47601610	Elect 47μF 16V
C619	1	1	1	1	OA47601610	Elect 47μF 16V
C620	1	1	1	1	OA47601610	Elect 47μF 16V
C621	1	1	1	1	OA47601610	Elect 47μF 16V
C630	1	1	1	1	DF15474350	Film 0.47μF ±5%
C631	1	1	1	1	DF15474350	Film 0.47μF ±5%
C632	1	1	1	1	DF16104310	Film 0.1μF ±10%
C633	1	1	1	1	DF16104310	Film 0.1μF ±10%
C634	1	1	1	1	DF16104310	Film 0.1μF ±10%
C635	1	1	1	1	DK46223300	Ceramic 0.022μF ±10%,Chip
C636	1	1	1	1	DK46223300	Ceramic 0.022μF ±10%,Chip
C637	1	1	1	1	DK46223300	Ceramic 0.022μF ±10%,Chip
C638	1	1	1	1	DK46223300	Ceramic 0.022μF ±10%,Chip
C639	1	1	1	1	DK46223300	Ceramic 0.022μF ±10%,Chip
C641	1	1	1	1	DK46152300	Ceramic 1500pF ±10%,Chip
C645	1	1	1	1	EA47602560	Elect 47μF 25V
C646	1	1	1	1	EA47602560	Elect 47μF 25V
C648	1	1	1	1	DK46223300	Ceramic 0.022μF ±10%,Chip
C650	1	1	1	1	DF15104350	Film 0.1μF ±5%
C651	1	1	1	1	DF15474350	Film 0.47μF ±5%
△C801	1	1	1	1	DF16104310	Film 0.1μF ±10%
△C802	1	1	1	1	DF16104310	Film 0.1μF ±10%
△C803	1	1	1	1	DF16104310	Film 0.1μF ±10%
△C804	1	1	1	1	DF16104310	Film 0.1μF ±10%
△C805	1	1	1	1	OA33802510	Elect 3300μF 25V
△C806	1	1	1	1	OA33802510	Elect 3300μF 25V
△C807	1	1	1	1	OA47801610	Elect 4700μF 16V
C808	1	1	1	1	OA10702510	Elect 100μF 25V
C809	1	1	1	1	OA33705010	Elect 330μF 50V
C810	1	1	1	1	OA33701610	Elect 330μF 16V

REF. DESIG.	Q'TY				PART NO.	DESCRIPTION
	U	N	A	F		
C811	1	1	1	1	OA33701610	Elect 330 μ F 16V
C812	1	1	1	1	OA33701010	Elect 330 μ F 10V
C813	1	1	1	1	OA33702510	Elect 330 μ F 25V
C814	1	1	1	1	OA10701010	Elect 100 μ F 10V
C815	1	1	1	1	OA33701010	Elect 330 μ F 10V
C820	1	1	1	1	DF16104310	Film 0.1 μ F \pm 10%
P501-RESISTORS (All Resistors are \pm 5% & 1/8W)						
R502	1	1	1	1	RI05824180	820K Ω , Chip
R503	1	1	1	1	GD05183140	18K Ω 1/4W
R504	1	1	1	1	RI05824180	820K Ω , Chip
R505	1	1	1	1	GD05184140	180K Ω 1/4W
R507	1	1	1	1	RI05183180	18K Ω , Chip
R510	1	1	1	1	GD05392140	3.9K Ω 1/4W
R511	1	1	1	1	RI05103180	10K Ω , Chip
R512	1	1	1	1	RI05104180	100K Ω , Chip
R513	1	1	1	1	RI05184180	180K Ω , Chip
R514	1	1	1	1	RI05105180	1M Ω , Chip
R515	1	1	1	1	GD05010140	1 Ω 1/4W
R516	1	1	1	1	RI05105180	1M Ω , Chip
R519	1	1	1	1	RI05222180	2.2K Ω , Chip
R520	1	1	1	1	RI05223180	22K Ω , Chip
R521	1	1	1	1	RI05223180	22K Ω , Chip
R523	1	1	1	1	RI05222180	2.2K Ω , Chip
R525	1	1	1	1	RI05222180	2.2K Ω , Chip
R527	1	1	1	1	RI05102180	1K Ω , Chip
R529	1	1	1	1	RI05223180	22K Ω , Chip
R530	1	1	1	1	RI05223180	22K Ω , Chip
R532	1	1	1	1	RI05332180	3.3K Ω , Chip
R534	1	1	1	1	RI05103180	10K Ω , Chip
R535	1	1	1	1	RI05104180	100K Ω , Chip
R536	1	1	1	1	RI05104180	100K Ω , Chip
R537	1	1	1	1	RI05274180	270K Ω , Chip
R538	1	1	1	1	RI05393180	39K Ω , Chip
R539	1	1	1	1	GD05010140	1 Ω 1/4W
R540	1	1	1	1	GD05472140	4.7K Ω 1/4W
R541	1	1	1	1	RI05472180	4.7K Ω , Chip
R542	1	1	1	1	RI05473180	47K Ω , Chip
R543	1	1	1	1	GD05104140	100K Ω 1/4W
R544	1	1	1	1	RI05472180	4.7K Ω , Chip
R548	1	1	1	1	GD05332140	3.3K Ω 1/4W
R549	1	1	1	1	GD05472140	4.7K Ω 1/4W
R550	1	1	1	1	RI05822180	8.2K Ω , Chip
R555	1	1	1	1	RI05102180	1K Ω , Chip
R558	1	1	1	1	RI05105180	1M Ω , Chip
R560	1	1	1	1	RI05102180	1K Ω , Chip
R563	1	1	1	1	RI05562180	5.6K Ω , Chip
R564	1	1	1	1	RI05102180	1K Ω , Chip
R565	1	1	1	1	RI05102180	1K Ω , Chip
R566	1	1	1	1	RI05102180	1K Ω , Chip
R567	1	1	1	1	RI05102180	1K Ω , Chip
R569	1	1	1	1	RI05000180	0 Ω , Chip
R570	1	1	1	1	RI05272180	2.7K Ω , Chip
R571	1	1	1	1	RI05101180	100 Ω , Chip
R572	1	1	1	1	RI05102180	1K Ω , Chip
R573	1	1	1	1	GD05105140	1M Ω 1/4W
R574	1	1	1	1	RI05182180	1.8K Ω , Chip
R576	1	1	1	1	RI05222180	2.2K Ω , Chip

REF. DESIG.	Q'TY				PART NO.	DESCRIPTION
	U	N	A	F		
R577	1	1	1	1	RI05222180	2.2K Ω , Chip
R578	1	1	1	1	RI05104180	100K Ω , Chip
R579	1	1	1	1	GD05103140	10K Ω 1/4W
R581	1	1	1	1	GD05470140	47 Ω 1/4W
R584	1	1	1	1	RI05820180	82 Ω , Chip
R585	1	1	1	1	RI05621180	620 Ω , Chip
R591	1	1	1	1	RI05272180	2.7K Ω , Chip
R592	1	1	1	1	RI05101180	100 Ω , Chip
R593	1	1	1	1	RI05102180	1K Ω , Chip
R594	1	1	1	1	GD05105140	1M Ω 1/4W
R595	1	1	1	1	RI05182180	1.8K Ω , Chip
R597	1	1	1	1	RI05222180	2.2K Ω , Chip
R598	1	1	1	1	RI05222180	2.2K Ω , Chip
R600	1	1	1	1	GD05103140	10K Ω , Chip
R602	1	1	1	1	GD05470140	47 Ω , Chip
R605	1	1	1	1	RI05820180	82 Ω , Chip
R606	1	1	1	1	RI05621180	620 Ω , Chip
R607	1	1	1	1	GD05151140	150 Ω , Chip
R608	1	1	1	1	GD05471140	470 Ω , Chip
R609	1	1	1	1	RI05104180	100K Ω , Chip
R610	1	1	1	1	RI05103180	10K Ω , Chip
R611	1	1	1	1	GD05473140	47K Ω , Chip
R612	1	1	1	1	RI05103180	10K Ω , Chip
R613	1	1	1	1	RI05103180	10K Ω , Chip
R614	1	1	1	1	RI05103180	10K Ω , Chip
R615	1	1	1	1	RI05223180	22K Ω , Chip
R616	1	1	1	1	GD05273140	27K Ω 1/4W
R617	1	1	1	1	RI05472180	4.7K Ω , Chip
R618	1	1	1	1	RI05473180	47K Ω , Chip
R619	1	1	1	1	RI05103180	10K Ω , Chip
R620	1	1	1	1	RI05000180	0 Ω , Chip
R621	1	1	1	1	RI05000180	0 Ω , Chip
R622	1	1	1	1	RI05000180	0 Ω , Chip
R623	1	1	1	1	RI05000180	0 Ω , Chip
R624	1	1	1	1	RI05221180	220 Ω , Chip
R625	1	1	1	1	RI05000180	0 Ω , Chip
R630	1	1	1	1	GA05056010	5.6 Ω 1W
R801	1	1	1	1	RI05471180	470 Ω , Chip
P501-SEMICONDUCTORS						
D539	1	1	1	1	HD40006030	Varicap SVC321SP
D540	1	1	1	1	HD40006030	Varicap SVC321SP
D545	1	1	1	1	HZ20002020	Chip Diode MA151WA
D546	1	1	1	1	HD20001210	Diode 1S2473
D547	1	1	1	1	HD20001210	Diode 1S2473
D549	1	1	1	1	HZ20001020	Chip Diode MA151WK
D551	1	1	1	1	HZ20001020	Chip Diode MA151WK
D557	1	1	1	1	HZ20005020	Chip Diode MA153
D559	1	1	1	1	HZ20002020	Chip Diode MA151WA
D560	1	1	1	1	HD30002020	Zener MA1039
Δ D801	1	1	1	1	HE20003030	Diode DBA20C
Δ D802	1	1	1	1	HE20003030	Diode DBA20C
Δ D803	1	1	1	1	HD20022030	Diode DSF10C-BT
Δ D804	1	1	1	1	HD20022030	Diode DSF10C-BT
Δ D805	1	1	1	1	HD20022030	Diode DSF10C-BT
D807	1	1	1	1	HD30041060	Zener RD6.8E

9. SEMICONDUCTORS ELECTRODES AND SCHEMATIC DIAGRAMS

REF. DESIG.	Q'TY				PART NO.	DESCRIPTION
	U	N	A	F		
SY01	1	1	1	1	SP01010800	PY01-MISCELLANEOUS Push Switch KHH15902
SY02	1	1	1	1	SP01010800	Push Switch KHH15902
SY03	1	1	1	1	SP01010800	Push Switch KHH15902
SY04	1	1	1	1	SP01010800	Push Switch KHH15902
SY05	1	1	1	1	SP01010800	Push Switch KHH15902
SY06	1	1	1	1	SP01010800	Push Switch KHH15902
SY07	1	1	1	1	SP01010800	Push Switch KHH15902
SY08	1	1	1	1	SP01010800	Push Switch KHH15902
SY09	1	1	1	1	SP01010800	Push Switch KHH15902
SY10	1	1	1	1	SP01010800	Push Switch KHH15902
WY02	1	1	1	1	YU07140260	Jumper Lead, 7P
PY02	1	1	1	1	YK105K1320 ZZ105K1320	PY02-7 SEG DRIVER CIRCUIT BOARD P.W. Board, 7 Seg Driver P.W. Board Assembly
CY02	1	1	1	1	OA10505010	PY02-CAPACITOR Elect 1 μ F 50V
RY09	1	1	1	1	GD05473140	PY02-RESISTORS 47K Ω \pm 5% $\frac{1}{4}$ W
RY10	1	1	1	1	GD05473140	47K Ω \pm 5% $\frac{1}{4}$ W
DY12	1	1	1	1	HD20001000	PY02-SEMICONDUCTORS Diode 1S1555
DY13	1	1	1	1	HD20001000	Diode 1S1555
QY03	1	1	1	1	HC10001260	IC MSM59371RS
QY04	1	1	1	1	HC10003260	IC MSM5937RS
JY01	1	1	1	1	YJ07001230	PY02-MISCELLANEOUS Jack
WY01	1	1	1	1	YU06080260	Jumper Lead, 6P
PY03	1	1	1	1	YK105K1330 ZZ105K1330	PY03-12 DOT DRIVER CIRCUIT BOARD P.W. Board, 12 Dot Driver P.W. Board Assembly
CY01	1	1	1	1	DK18103300	PY03-CAPACITOR Ceramic 0.01 μ F
RY01	1	1	1	1	GD05470140	PY03-RESISTORS (All Resistors are \pm 5% & $\frac{1}{4}$ W) 47 Ω
RY02	1	1	1	1	GD05151140	150 Ω
RY03	1	1	1	1	GD05221140	220 Ω
RY04	1	1	1	1	GD05470140	47 Ω
RY05	1	1	1	1	GD05510140	51 Ω
RY06	1	1	1	1	GD05151140	150 Ω
RY07	1	1	1	1	GD05221140	220 Ω
RY08	1	1	1	1	GD05470140	14 Ω
RY17	1	1	1	1	GD05103140	10K Ω
RY18	1	1	1	1	GD05330140	33 Ω

REF. DESIG.	Q'TY				PART NO.	DESCRIPTION
	U	N	A	F		
DY10	1	1	1	1	HD20001000	PY03-SEMICONDUCTORS Diode 1S1555
DY11	1	1	1	1	HD20001000	Diode 1S1555
QY01	1	1	1	1	HC10001260	IC MSM59371RS
QY02	1	1	1	1	HC10002260	IC MSM5837RS
QY05	1	1	1	1	HT206321F0	Transistor 2SB632K(F)
QY06	1	1	1	1	HT107331P0	Transistor 2SA733(P)
QY07	1	1	1	1	HT206321F0	Transistor 2SB632K(F)
QY08	1	1	1	1	HT107331P0	Transistor 2SA733(P)
JY02	1	1	1	1	YJ07001180	PY03-MISCELLANEOUS Jack
JY03	1	1	1	1	YJ06003080	Jack

NOTE ON SAFETY:
SYMBOL \triangle FIRE OR ELECTRICAL SHOCK HAZARD.
ONLY ORIGINAL PARTS SHOULD BE USED TO REPLACE ANY PART MARKED WITH SYMBOL \triangle .
ANY OTHER COMPONENT SUBSTITUTION (OTHER THAN ORIGINAL TYPE), MAY INCREASE RISK OF FIRE OR ELECTRICAL SHOCK HAZARD.

(W01-99)	Assembly and Wiring
(T01-99)	Adjustment
(X01-00)	Correction

	2SC945 (PorQ) (HT309452B0) 2SA733 (P) (HT107331P0)	FRONT VIEW 	BA6109 (HC10025210)
	2SA1184 (Y) (HT111841Y0) 2SC2824 (Y) (HT328241Y0)	TOP VIEW 	HD145388 (HC45380680)
	2SC1384 (R) (HT313841R0) 2SA684 (R) (HT106841R0)	TOP VIEW 	μ PC324C (HC10082060) μ PD4011BC (HC40110040)
	2SB632K (F) (HT206321F0)	TOP VIEW 	HD14070B (HC10057010) HD74LS74A (HC10058010)
	μ PC7805H (HC10056060) μ PC7812H (HC10043060)	TOP VIEW 	SAA7010 (HC10022270)
	μ PC7912H (HC10044060) μ PC7918H (HC10079060)	TOP VIEW 	SAA7020 (HC10023270)
	2SC2712 (G) (HX327121A0)	TOP VIEW 	SAA7030 (HC10024270) MSM5937RS (HC10003260)
	UN2114 PNP (BA10001020)	TOP VIEW 	SAA7000 (HC10021270)
	UN2215 NPN (BA20001020)	TOP VIEW 	μ PD4016C (HC10098060)
	μ PC339C (HC10081060) μ PC741C (HC10083060) μ PD393C (HC10084060)	TOP VIEW 	NJM4558D (HC10003090) JRC4560DD (HC10021090)
	2SC3381 G.R. (HT333811G0)	TOP VIEW 	HD140538 (HC10056010) 74LS166 (HC716600A0)
	HD14025B (HC10055010)	TOP VIEW 	MSM59371RS (HC10001260)
	μ PD1512ACU (HC10093060)	TOP VIEW 	MSM5837RS (HC10002260)

10. SPECIFICATIONS

GENERAL

Disc Diameter	120 mm
Number of Channels	2
Track Pitch	1.6 μ m
Scanning Speed	1.2 ~ 1.4 m/sec.

SIGNAL FORMAT

Sampling Frequency	44.1 kHz
Quantization	16 bit linear
Modulation System	EFM
Channel Bit Rate	4.3218 Mb/sec.
Error Correction	CIRC
Encode System	2S complement

OPTICAL PICK-UP

Semiconductor Wavelength	0.78 μ m
Number of Opening (NA)	0.45
Focus Depth	$\pm 2 \mu$ m
Beam Spot Diameter (at disc surface)	Approx. 1 mm

ELECTRICAL CHARACTERISTICS

Output	2.0 V
Frequency Response	3 Hz ~ 20 kHz
Signal-to-noise Ratio	More than 90 dB
Dynamic Range	More than 90 dB
Total Harmonic Distortion	0.003% (1 kHz)
Wow and Flutter	Below measurable limits
De-emphasis	Automatic switching

OTHERS

Power Supply	polystyrene with extruded aluminium profiles
	This model is convertible to 110/120/220/240 volts by changing voltage selector on the bottom panel.
Power Consumption	30 W
Dimensions (W) x (H) x (D)	320 x 90 x 291 mm
Weight	6.5 kg

Specifications and appearance are subject to change modification without notice.

SCHMATIC DIAGRAMS

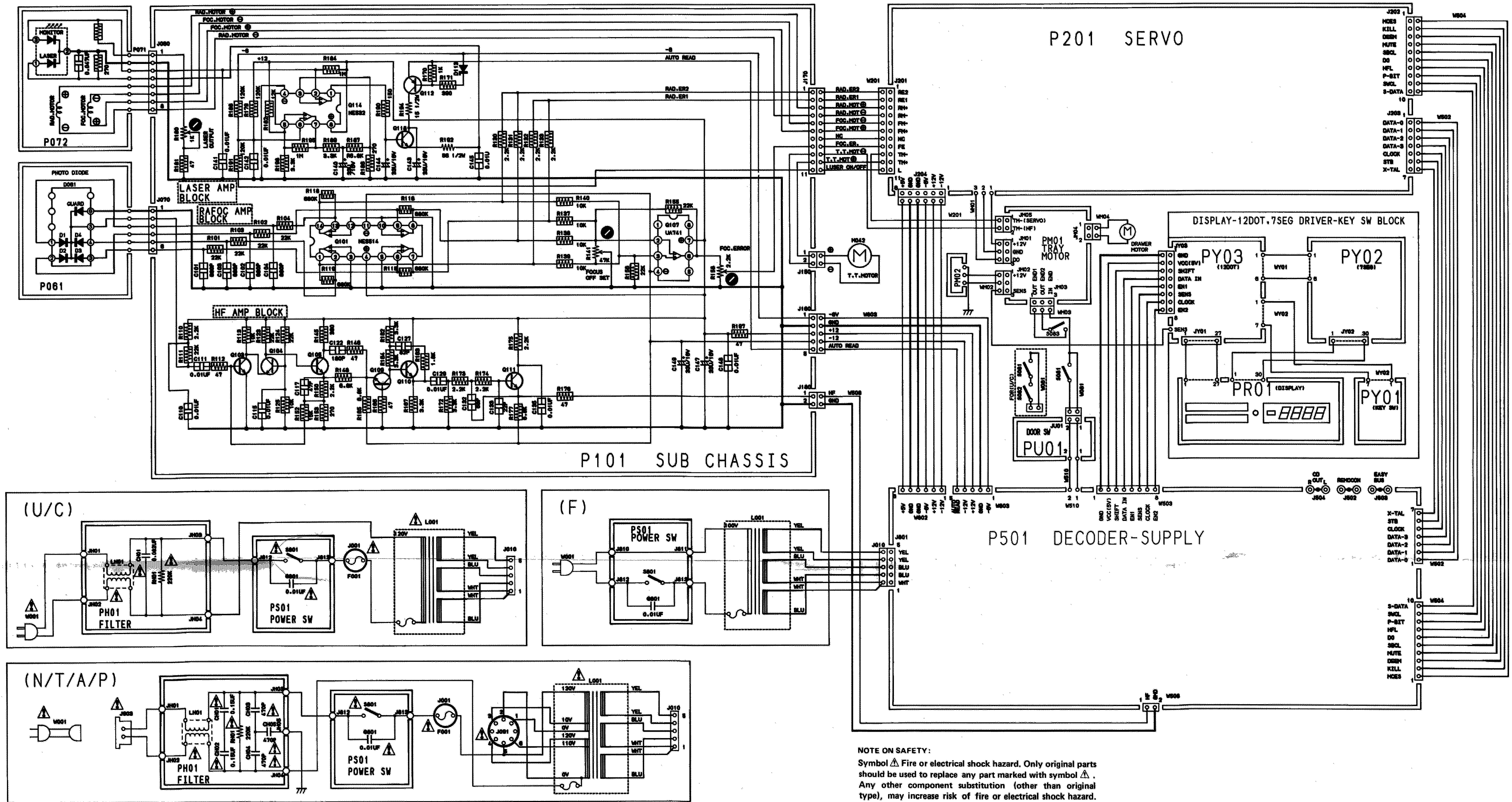

Components and wiring are subject to change for modification without notice.

NOTE ON SAFETY:
 Symbol ⚠ Fire or electrical shock hazard. Only original parts should be used to replace any part marked with symbol ⚠. Any other component substitution (other than original type), may increase risk of fire or electrical shock hazard.

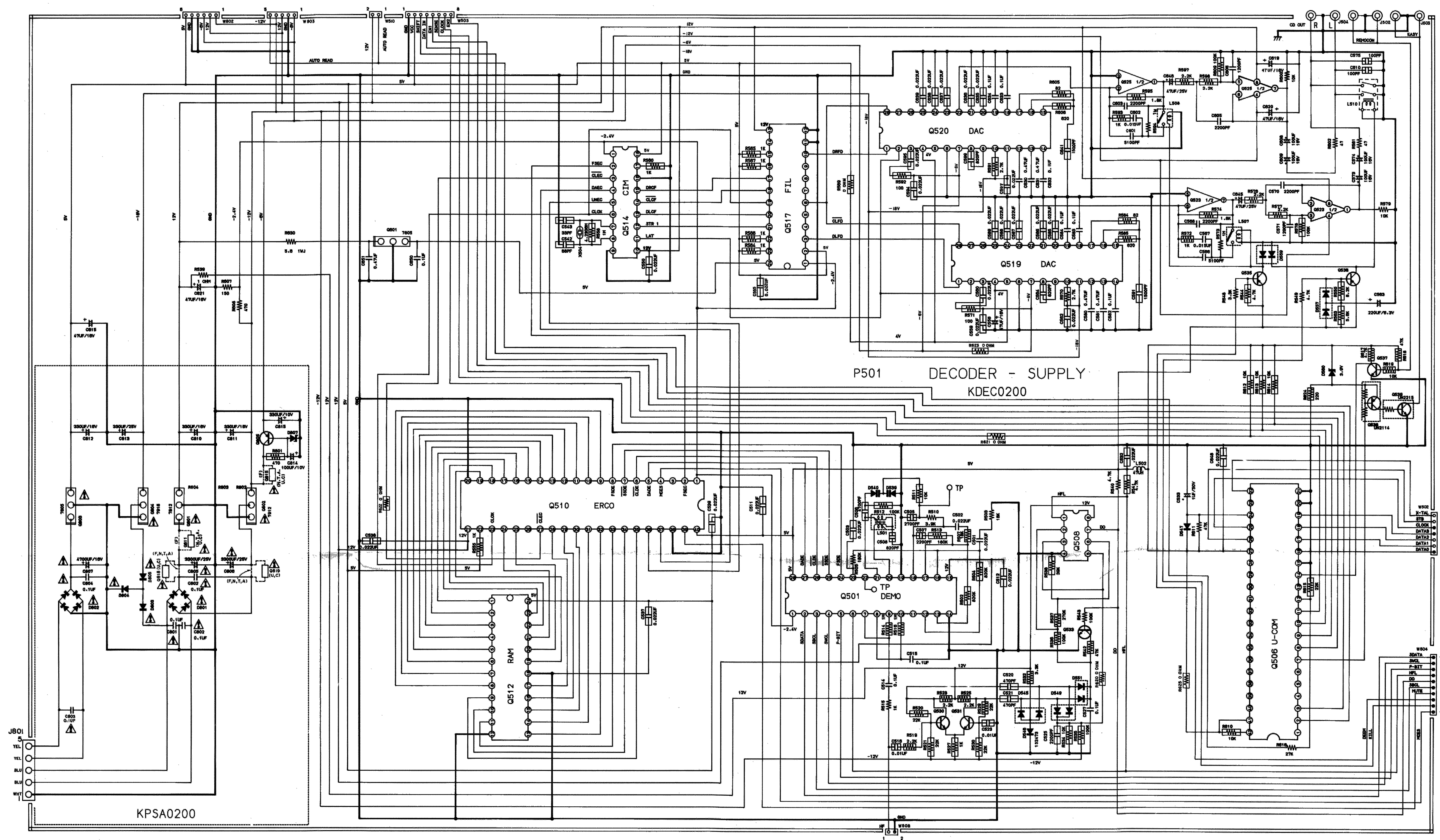

KPSA0200

P501 DECODER - SUPPLY
KDEC0200

J501
5
YEL
BLU
BLU
WHT

W504
DATA
P-RET
DO
DATA
DATA
DATA

Q506 U-COM

Q501 TP DEMO

Q510 ERCO

Q512 RAM

Q520 DAC

Q519 DAC

Q514 CTM

Q517 FIL

Q521

Q514

Q521

Q514

Q521

Q514

Q521

Q514

Q521

Q514

Q521

Q514

Q521

Q514

Q521

Q514

Q521

Q514

Q521

Q514

Q521

Q514

Q521

Q514

Q521

Q514

Q521

Q514

Q521

Q514

Q521

Q514

Q521

Q514

Q521

Q514

Q521

Q514

Q521

Q514

Q521

Q514

Q521

Q514

Q521

Q514

Q521

Q514

Q521

Q514

Q521

Q514

Q521

Q514

Q521

Q514

Q521

Q514

Q521

Q514

Q521

Q514

Q521

Q514

Q521

Q514

Q521

Q514

Q521

Q514

Q521

Q514

Q521

Q514

Q521

Q514

Q521

Q514

Q521

Q514

Q521

Q514

Q521

Q514

Q521

Q514

Q521

Q514

Q521

Q514

Q521

Q514

Q521

Q514

Q521

Q514

Q521

Q514

Q521

Q514

Q521

Q514

Q521

Q514

Q521

Q514

Q521

Q514

Q521

Q514

Q521

Q514

Q521

Q514

Q521

Q514

Q521

Q514

Q521

Q514

Q521

Q514

Q521

Q514

Q521

Q514

Q521

Q514

Q521

Q514

Q521

Q514

Q521

Q514

Q521

Q514

Q521

Q514

Q521

Q514

Q521

Q514

Q521

Q514

Q521

Q514

Q521

Q514

Q521

Q514

Q521

Q514

Q521

Q514

Q521

Q514

Q521

Q514

Q521

Q514

Q521

Q514

Q521

Q514

Q521

Q514

Q521

Q514

Q521

Q514

Q521

Q514

Q521

Q514

Q521

Q514

Q521

Q514

Q521

Q514

Q521

Q514

Q521

Q514

Q521

Q514

Q521

Q514

Q521

Q514

Q521

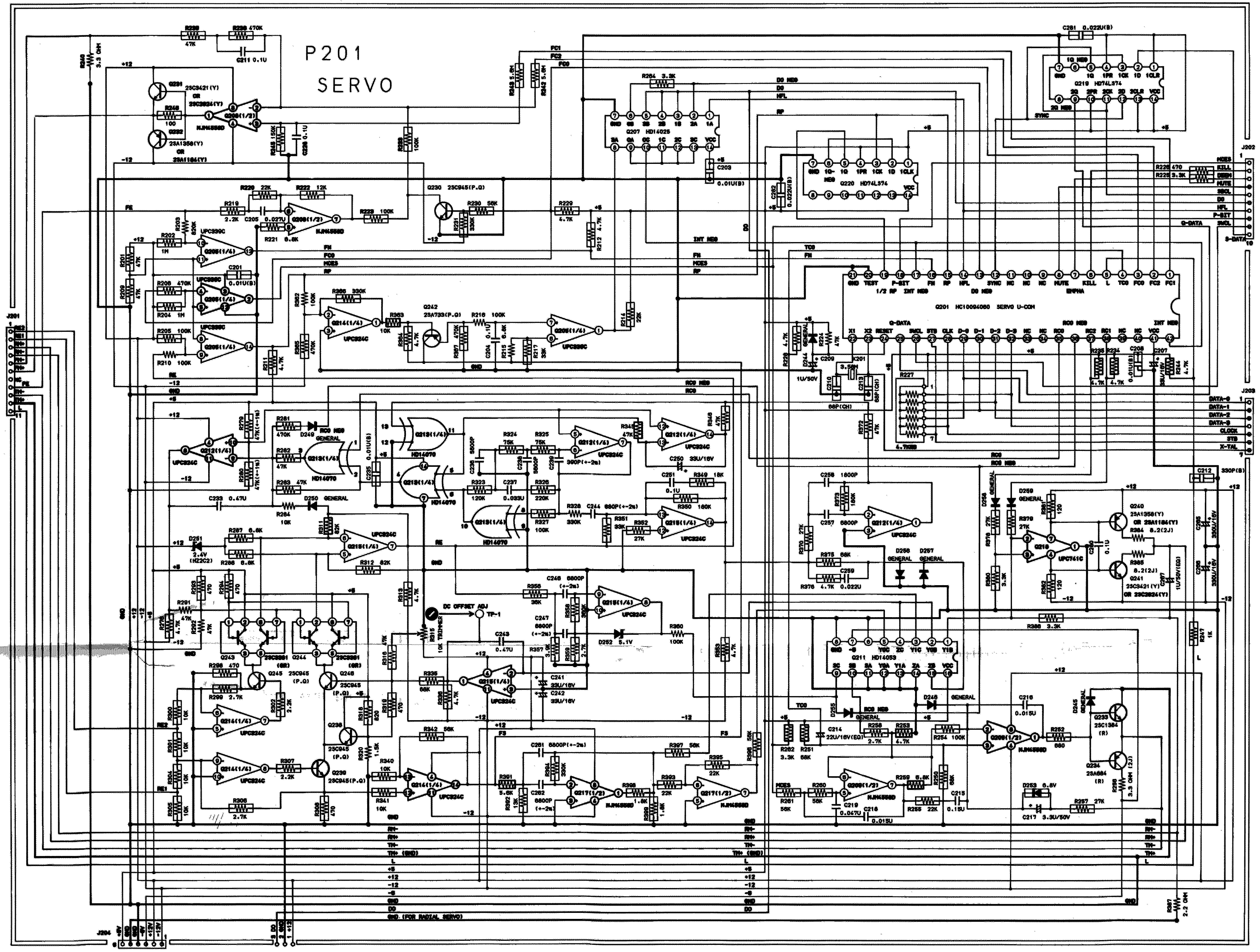

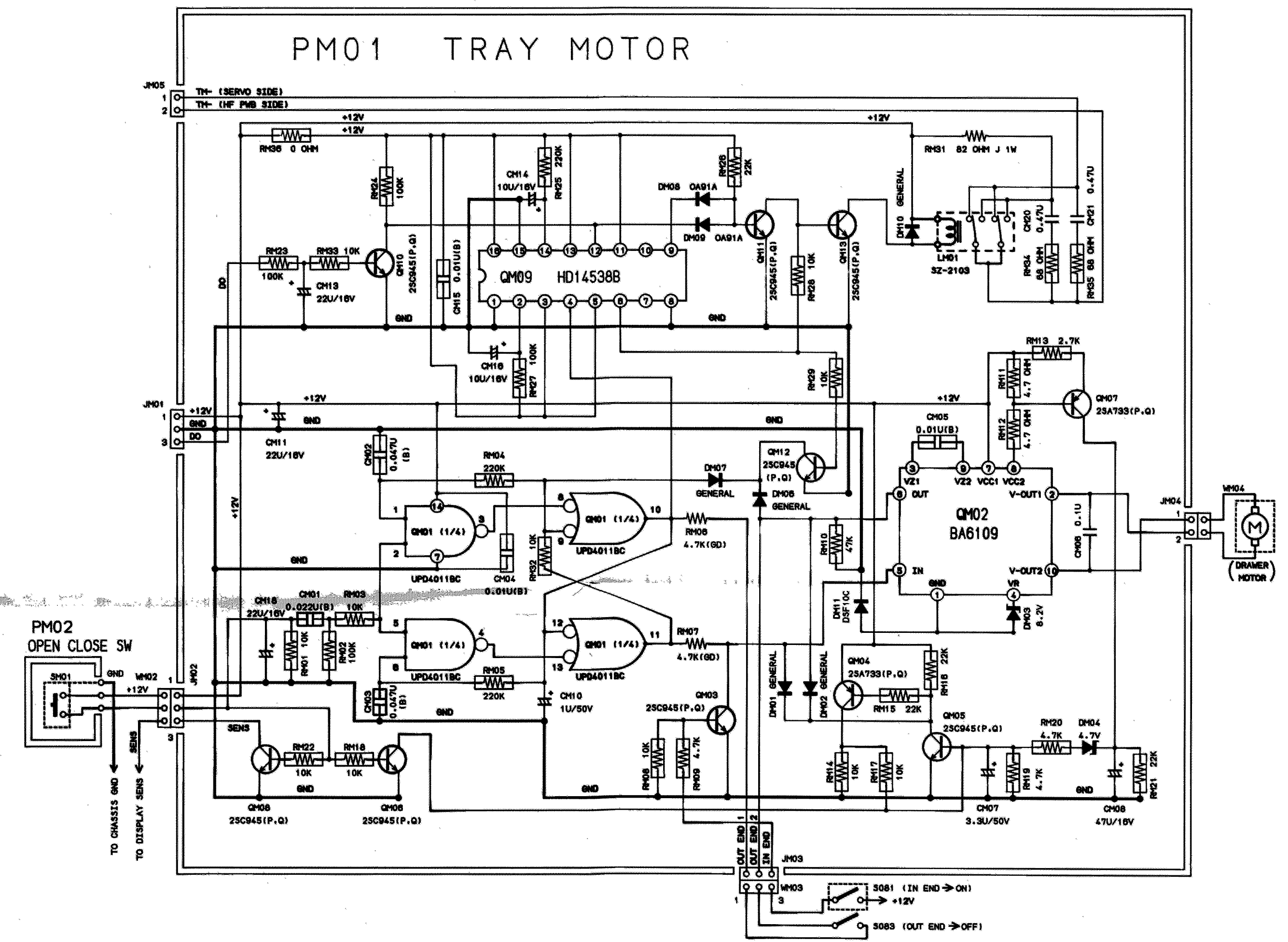
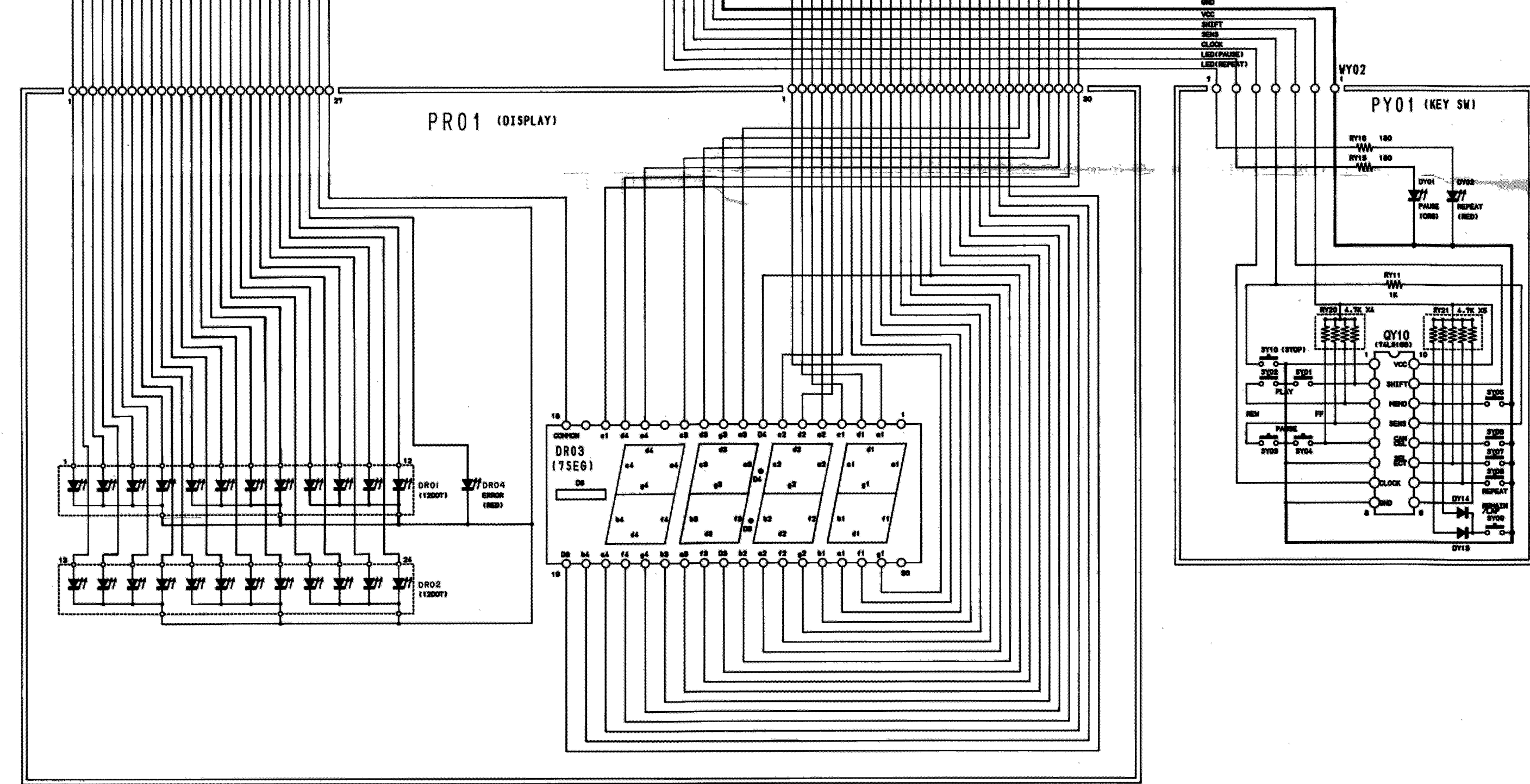
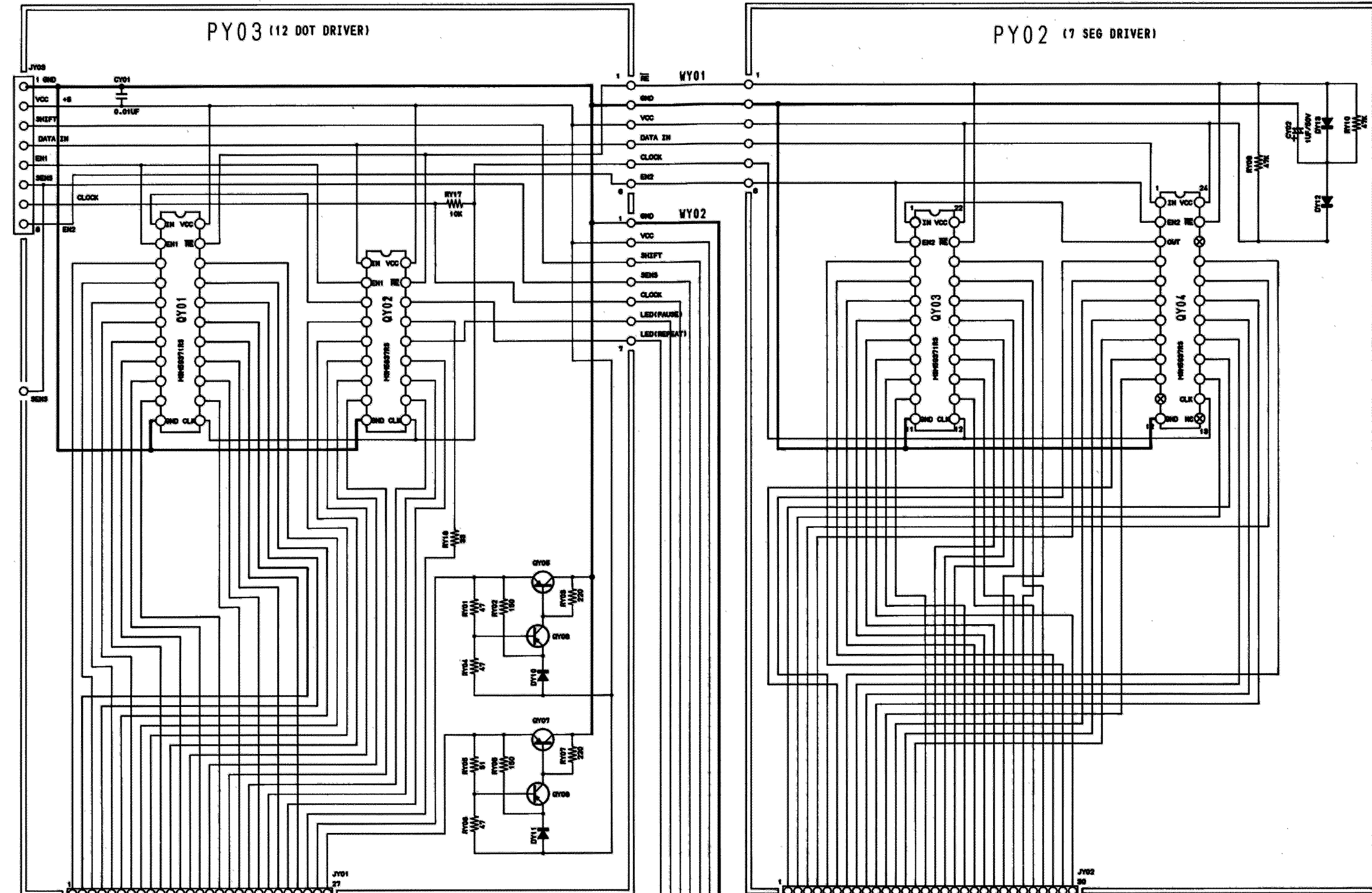



marantz®

MARANTZ is a registered trademark