

Service Manual

CD6003 /F N/K1SG/N1B/N1SG

CD Player

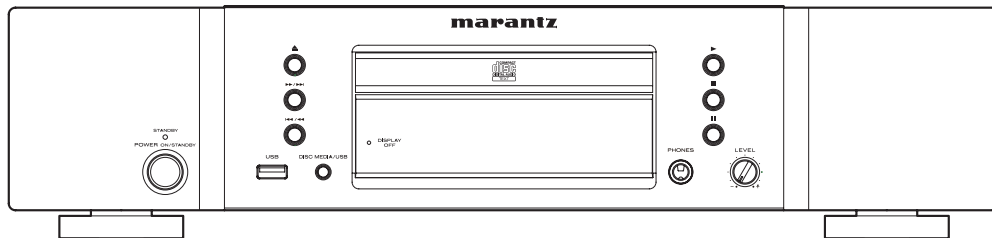

CD6003

TABLE OF CONTENTS

SECTION	PAGE
1. TECHNICAL SPECIFICATIONS.....	1
2. SERVICE HINTS AND TOOLS	2
3. WARNING AND LASER SAFETY INSTRUCTIONS	3
4. TAKING THE DISC OUT OF EMERGENCY	4
5. SERVICE MODE	4
6. ALL CLEAR	8
7. ERROR MESSAGE	8
8. TROUBLESHOOTING.....	20
9. UPDATE MICROPROCESSOR SOFTWARE PROCEDURE	22
10. WIRING DIAGRAM.....	33
11. BLOCK DIAGRAM.....	35
12. SCHEMATIC DIAGRAM	37
13. PARTS LOCATION	43
14. EXPLODED VIEW AND PARTS LIST	53
15. MICROPROCESSOR AND IC DATA.....	57
16. ELECTRICAL PARTS LIST.....	65
17. ABOUT REPLACE THE MICROPROCESSOR WITH A NEW ONE.....	78

Please use this service manual with referring to the user guide (D.F.U.) without fail.
修理の際は、必ず取扱説明書を準備し操作方法を確認の上作業を行ってください。

marantz®

CD6003

MARANTZ DESIGN AND SERVICE

Using superior design and selected high grade components, **MARANTZ** company has created the ultimate in stereo sound. Only original **MARANTZ** parts can insure that your **MARANTZ** product will continue to perform to the specifications for which it is famous.

Parts for your **MARANTZ** equipment are generally available to our National Marantz Subsidiary or Agent.

ORDERING PARTS :

Parts can be ordered either by mail or by Fax.. In both cases, the correct part number has to be specified.

The following information must be supplied to eliminate delays in processing your order :

1. Complete address
2. Complete part numbers and quantities required
3. Description of parts
4. Model number for which part is required
5. Way of shipment
6. Signature : any order form or Fax. must be signed, otherwise such part order will be considered as null and void.

USA

MARANTZ AMERICA, INC
100 CORPORATE DRIVE
MAHWAH, NEW JERSEY 07430
USA

EUROPE / TRADING

D&M EUROPE B. V.
P. O. BOX 8744, BUILDING SILVERPOINT
BEEMDSTRAAT 11, 5653 MA EINDHOVEN
THE NETHERLANDS
PHONE : +31 - 40 - 2507844
FAX : +31 - 40 - 2507860

CANADA

D&M Canada Inc.
5-505 APPLE CREEK BLVD.
MARKHAM, ONTARIO L3R 5B1
CANADA
PHONE : 905 - 415 - 9292
FAX : 905 - 475 - 4159

JAPAN

D&M Holdings Inc.
D&M BUILDING, 2-1 NISSHIN-CHO,
KAWASAKI-KU, KAWASAKI-SHI,
KANAGAWA, 210-8569 JAPAN

株式会社 ディーアンドエムホールディングス

本 社 〒210-8569
神奈川県川崎市川崎区日進町2-1 D&Mビル



KOREA

D&M SALES AND MARKETING KOREA LTD.
CHUNG JIN B/D., #1001,
53-5, WONHYORO 3 GA, YONGSAN-GU,
SEOUL, 140-719, KOREA
PHONE : +82 - 2 - 323 - 2155
FAX : +82 - 2 - 323 - 2154

CHINA

D&M SALES AND MARKETING SHANGHAI LTD.
ROOM.808 SHANGHAI AIRPORT CITY TERMINAL
NO.1600 NANJING (WEST) ROAD, SHANGHAI,
CHINA. 200040
TEL : 021 - 6248 - 5151
FAX : 021 - 6248 - 4434

NOTE ON SAFETY :

Symbol  Fire or electrical shock hazard. Only original parts should be used to replaced any part marked with symbol  . Any other component substitution (other than original type), may increase risk of fire or electrical shock hazard.

安全上の注意 :

 がついている部品は、安全上重要な部品です。必ず指定されている部品番号のものを使用して下さい。

SHOCK, FIRE HAZARD SERVICE TEST :

CAUTION : After servicing this appliance and prior to returning to customer, measure the resistance between either primary AC cord connector pins (with unit NOT connected to AC mains and its Power switch ON), and the face or Front Panel of product and controls and chassis bottom.

Any resistance measurement less than 1 Megohms should cause unit to be repaired or corrected before AC power is applied, and verified before it is return to the user/customer.

Ref. UL Standard No. 60065.

In case of difficulties, do not hesitate to contact the Technical Department at above mentioned address.

1. TECHNICAL SPECIFICATIONS

Audio characteristics

Channels 2 channels
 Frequency response 2 Hz to 20 kHz
 Dynamic range 100 dB
 Signal-to-noise ratio (A-weighted) 110 dB
 Channel separation (1 kHz) 110 dB
 Harmonic distortion (1 kHz) 0.002%
 Wow & flutter Precision of quartz
 Audio output 2.35 V rms, stereo
 Headphone output (variable maximum) ... 18 mW/32 ohms
 Digital output
 Coaxial output (pin jack) 0.5 Vp-p, 75 ohms
 Optical output (square optical connector) -19 dBm

Optical readout system

Laser AlGaAs semiconductor
 Wavelength 780 nm

Dimensions (unit: mm)

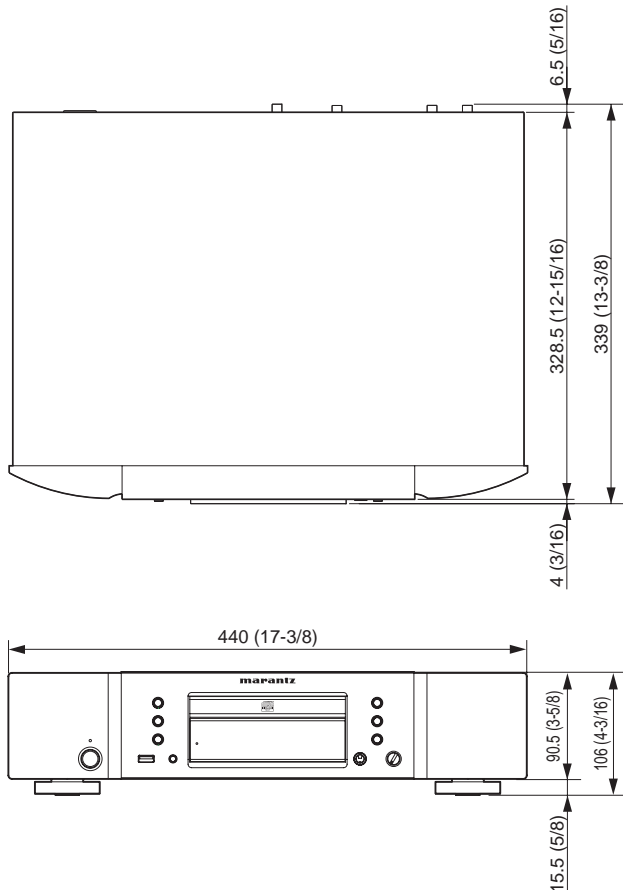

Signal system

Sampling frequency 44.1 kHz
 Quantization 16-bit linear PCM

Power supply

Power requirement AC 230 V 50/60 Hz
 Power consumption 19 W
 Standby power consumption 0.3 W

规格 [K version only]

音频特性

模拟输出 (载荷=10kΩ Ref=1kHz)

声道 2 声道
 频率响应 4Hz 到 20kHz (Ref=0dB, ±3dB)
 动态范围 (使用 FLP-A20k 时) 90dB (Ref=-60dB)
 信噪比 (使用 FLP-A20k 时) 90dB (Ref=0dB)
 全频失真 (使用 FLP-A20k 时) 0.008% (Ref=0dB)
 抖动度 石英精度
 输出水平 2.35±0.3V rms

数字输出

水平输出 (同轴) 0.5V±0.1Vp-p, 75Ω
 水平输出 (光学) -19 dBm ±3 dBm

光学读取系统

激光 AlGaAs 半导体激光
 波长 760 - 800nm

信号系统

采样频率 44.1kHz
 量化 16 位线性 PCM

电源

电源要求 交流 220V 50Hz
 功耗 19W
 待机电源消耗 <0.5W

机箱等

允许的工作温度 +5 ~ +35°C
 允许的工作湿度 5 ~ 90% (无结露)

2. SERVICE HINTS AND TOOLS

SERVICE HINTS

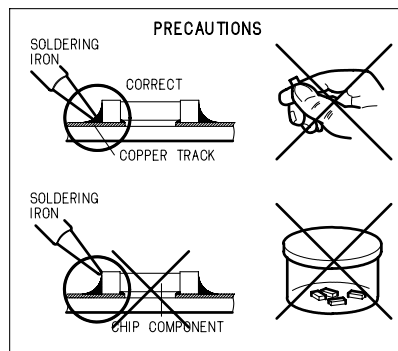
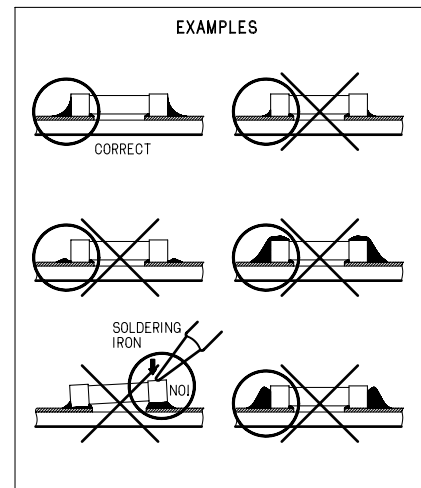
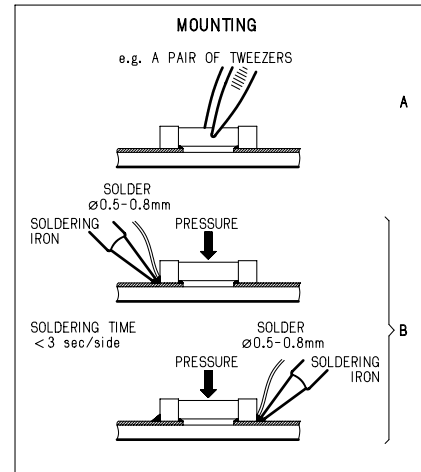
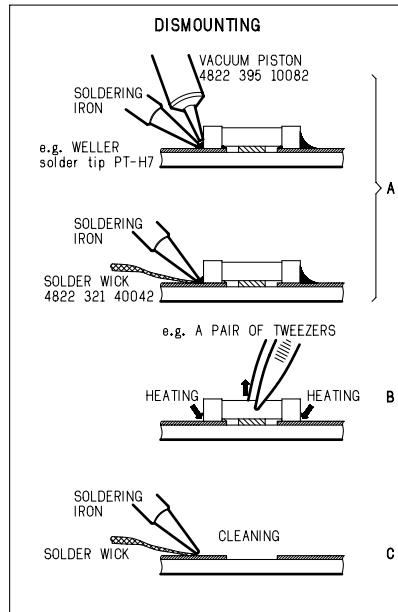
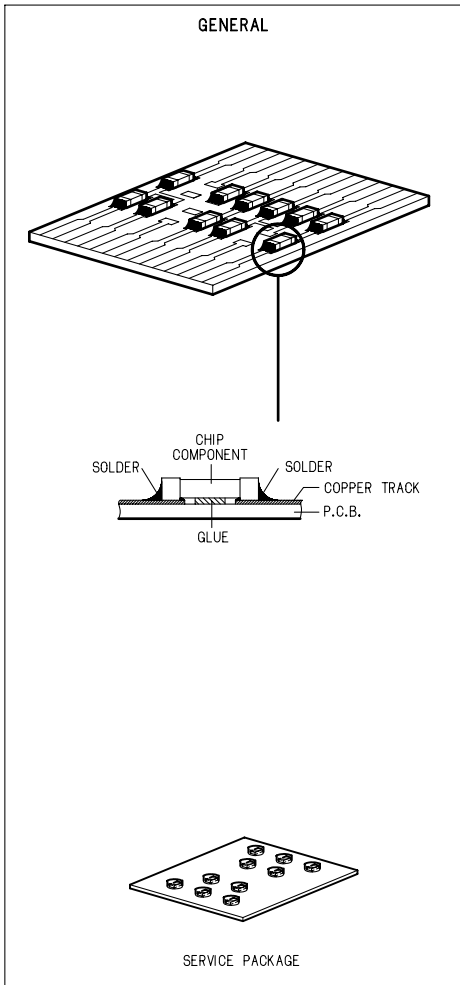

SERVICE TOOLS

Audio signals disc	4822 397 30184 or TCD-784
Disc without errors +	
Disc with DO errors, black spots and fingerprints	4822 397 30245 (SBC444A) or TCD-726
Disc (65 min 1kHz) without no pause	4822 397 30155
Max. diameter disc (58.0 mm)	4822 397 60141
Torx screwdrivers	
Set (straight)	4822 395 50145
Set (square)	4822 395 50132
13th order filter	4822 395 30204
DVD test disc (PAL)	4822 397 10131
DVD test disc (NTSC) ALMEDIO	TDV-540

070703MZ

3. WARNING AND LASER SAFETY INSTRUCTIONS

GB WARNING

All ICs and many other semi-conductors are susceptible to electrostatic discharges (ESD). Careless handling during repair can reduce life drastically.
When repairing, make sure that you are connected with the same potential as the mass of the set via a wrist wrap with resistance.
Keep components and tools also at this potential.



NL WAARSCHUWING

Alle IC's en vele andere halfgeleiders zijn gevoelig voor elektrostatische ontladingen (ESD).
Onzorgvuldig behandelen tijdens reparatie kan de levensduur drastisch doen verminderen.
Zorg ervoor dat u tijdens reparatie via een polsband met weerstand verbonden bent met hetzelfde potentiaal als de massa van het apparaat.
Houd componenten en hulpmiddelen ook op hetzelfde potentiaal.

F ATTENTION

Tous les IC et beaucoup d'autres semi-conducteurs sont sensibles aux décharges statiques (ESD).
Leur longévité pourrait être considérablement écourtée par le fait qu'aucune précaution n'est prise à leur manipulation.
Lors de réparations, s'assurer de bien être relié au même potentiel que la masse de l'appareil et enfiler le braceleterti d'une résistance de sécurité.
Veiller à ce que les composants ainsi que les outils que l'on utilise soient également à ce potentiel.

D WARNUNG

Alle IC und viele andere Halbleiter sind empfindlich gegen elektrostatische Entladungen (ESD).
Unsorgfältige Behandlung bei der Reparatur kann die Lebensdauer drastisch vermindern.
Sorgen sie dafür, das Sie im Reparaturfall über ein Pulsarmband mit Widerstand mit dem Massepotential des Gerätes verbunden sind.
Halten Sie Bauteile und Hilfsmittel ebenfalls auf diesem Potential.

I AVVERTIMENTO

Tutti IC e parecchi semi-conduttori sono sensibili alle scariche statiche (ESD).
La loro longevità potrebbe essere fortemente ridatta in caso di non osservazione della più grande cauzione alla loro manipolazione.
Durante le riparazioni occorre quindi essere collegato allo stesso potenziale che quello della massa dell'apparecchio tramite un braccialetto a resistenza.
Assicurarsi che i componenti e anche gli utensili con quali si lavora siano anche a questo potenziale.

GB

Safety regulations require that the set be restored to its original condition and that parts which are identical with those specified be used.

NL

Veiligheidsbepalingen vereisen, dat het apparaat in zijn oorspronkelijke toestand wordt terug gebracht en dat onderdelen, identiek aan de gespecificeerde worden toegepast.

D

Bei jeder Reparatur sind die geltenden Sicherheitsvorschriften zu beachten.
Der Originalzustand des Gerats darf nicht verändert werden.
Für Reparaturen sind Original-Ersatzteile zu verwenden.

I

Le norme di sicurezza esigono che l'apparecchio venga rimesso nelle condizioni originali e che siano utilizzati pezzi di ricambio identici a quelli specificati.

F

"Pour votre sécurité, ces documents doivent être utilisés par des spécialistes agréés, seuls habilités à réparer votre appareil en panne."

Les normes de sécurité exigent que l'appareil soit remis à l'état d'origine et que soient utilisées les pièces de rechange identiques à celles spécifiées.

LASER SAFETY

This unit employs a laser. Only a qualified service person should remove the cover or attempt to service this device, due to possible eye injury.



USE OF CONTROLS OR ADJUSTMENTS OR PERFORMANCE OF PROCEDURE OTHER THAN THOSE SPECIFIED HEREIN MAY RESULT IN HAZARDOUS RADIATION EXPOSURE.

AVOID DIRECT EXPOSURE TO BEAM

WARNING

**The use of optical instruments with this product will increase eye hazard.
Repair handling should take place as much as possible with a disc loaded inside the player**

WARNING LOCATION: INSIDE ON LASER COVERSIELD

CAUTION VISIBLE AND INVISIBLE LASER RADIATION WHEN OPEN AVOID EXPOSURE TO BEAM
ADVARSEL SYNLIG OG USYNLIG LASERSTRÅLING VED ÅBNING UNDGÅ UDSÆTTELSE FOR STRÅLING
ADVARSEL SYNLIG OG USYNLIG LASERSTRÅLING NÅR DEKSEL Å PNES UNNGÅ EKSPONERING FOR STRÅLEN
VARNING SYNLIG OCH OSYNLIG LASERSTRÅLNING NÅR DENNA DEL ÅR ÖPPNAD BETRAKTA EJ STRÅLEN
VARO! AVATT AESSA OLET ALTTIINA NÄKYVÄLLE JA NÄKYMÄTTÖMÄLLE LASER SÄTEILYLLE. ÄLÄ KATSO SÄTEESEEN
VORSICHT SICHTBARE UND UNSICHTBARE LASERSTRAHLUNG WENN ABDECKUNG GEÖFFNET NICHT DEM STRAHL AUSSETZEN
DANGER VISIBLE AND INVISIBLE LASER RADIATION WHEN OPEN AVOID DIRECT EXPOSURE TO BEAM
ATTENTION RAYONNEMENT LASER VISIBLE ET INVISIBLE EN CAS D'OUVERTURE EXPOSITION DANGEREUSE AU FAISCEAU

4. TAKING THE DISC OUT OF EMERGENCY

1. Remove the top cover of the player.
2. Remove 2 screws shown in the picture follows.
3. Remove the disc clamber.
4. Now you can remove the disc.

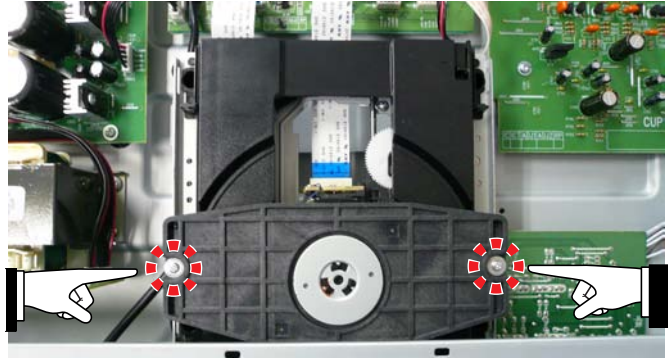

Remove those screws

5. SERVICE MODE

There are two modes in the service mode.

サービスモードには2種類あり、各モジュールのバージョン情報
を表示するモードとラストエラーメッセージを確認するモードがあ
ります。

**[A] Mode to display version information on each
module.**

[A] 各モジュールのバージョン情報等を表示するモード

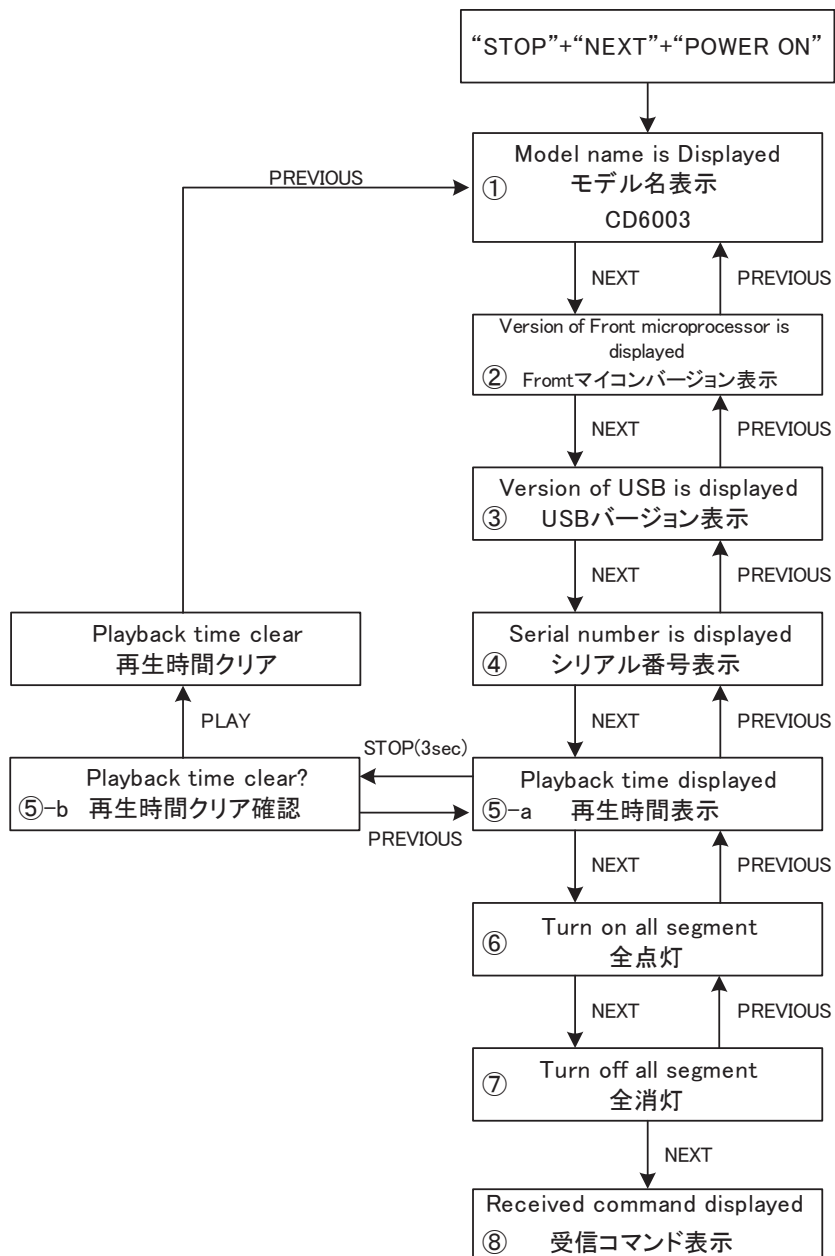

Here is the indication and specification of each function.

以下に、それぞれの表示及び仕様を示します。

1. Model name is displayed.

1. モデル名表示

モデル名をFLに表示します。



2. Version of FRONT microprocessor is displayed.

2. Front マイコンバージョン表示

フロントマイコンのバージョン表示を行います。

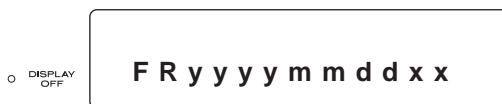

3. Version of USB device is displayed.

3. USBバージョン表示

First, Revision of USB device is displayed.

USBデバイスのバージョン情報を表示します。
まず、LSIのデバイスのリビジョンを表示します。

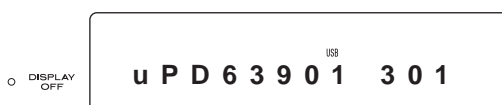

Press **NEXT** button, then version of USB is displayed.

NEXT キーが押されるとバージョン情報を表示します。

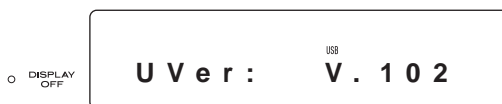

Push **PREVIOUS** button then Revision of USB device is displayed.

PREVIOUS キーが押されると LSI のリビジョン表示に復帰します。

Revision of USB is display of LSI when the **PREVIOUS** button is pushed when light up all FL segment.

又、全点灯表示を行っている際、**PREVIOUS** キーが押されると、LSI のリビジョン表示に復帰します。

4. Serial number is displayed.

4. シリアル番号表示

シリアル番号の表示を行います。



5-a. CD playback time is displayed.

5-a. 再生時間表示

It is only a HOUR display.

CD及びSA-CDのそれぞれの再生時間を表示します。
再生時間は、分秒の表示は行わないものとします。但し、再生時間のカウンタは秒単位でカウントを行っています。

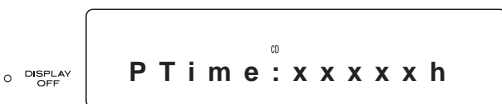

To be displayed backup time , press **PLAY** button.

再生時間を表示中に **PLAY** キーが入力されると、バックアップされた再生時間を表示します。これは、CDモジュールを交換した際、次項の再生時間クリアを行いますが、その時に交換する前のCDモジュールの再生時間をメモリにバックアップし、その情報を確認することが可能です。

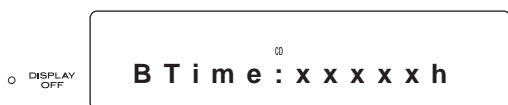

To be displayed playback time, press **PUSE** button.

PAUSE キーが入力されると、現在の再生時間表示に復帰します。

5-b. Confirmation of to do clear playback time

When replacing SUPER AUDIO CD module and reset playback times.

Press the **STOP** button more than 3 seconds while playback time is displayed.



Press **PLAY** Button.



xxx : number of changed CD module

The display is as follows.

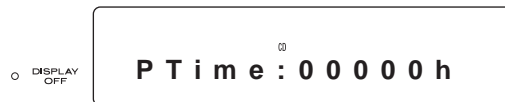

Press the **PREVIOUS** button while confirmation of to do clear playback time.

6. Light up all FL segment

The icon and the character representation are displayed every second. Standby LED doesn't light.

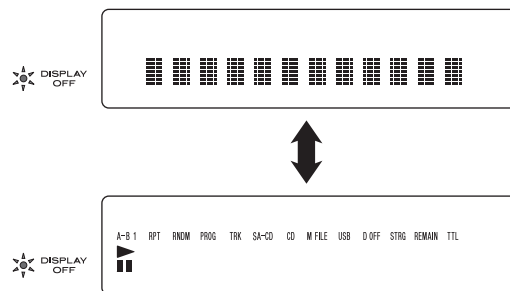

7. Light off all FL segment



8. Confirmation of remote control command

The command input by a key and a remote controller is displayed.

When the **STANDBY** button is pressed or Standby RC code is received, it shifts to Standby.

5-b. 再生時間クリア確認

CD モジュールを交換した場合、再生時間をクリアする必要があります。

再生時間表示中に **STOP** キーを3秒以上長押しで再生時間クリア確認表示に移行します。

この表示中に **PLAY** キーを押すと再生時間がクリアされます。再生時間がクリアされると以下の表示に切り替わります。

ここで、表示中の xxx は CD モジュールの交換履歴になります。この表示を約 3 秒間表示行くと再生時間がクリアされたことを示すために以下の表示を行います。

再生時間クリア確認表示中に **PREVIOUS** キーが押されると再生時間表示に復帰します。

6. 全点灯

使用する部品が全点灯を禁止としているため、ICON 部と文字表示部を 1 秒毎に交互に表示させます。

但し、Standby LED に関しては、Standby 機能と連動しているため、全点灯時にも点灯することはありません。

7. 全消灯

全ての表示を消灯します。

8. 受信コマンド表示

フロントにあるキー及びリモートコントローラーから入力されるコマンドを表示部に表示します。

但し、**STANDBY** キーが押された場合 Standby に移行します。同様にリモートコントローラーより Power OFF 及び Power On/Off コマンドを受信した場合も Standby に移行します。

[B] The mode to check the last error message etc.

This test mode is common to all models.

[B] ラストエラーメッセージなどを確認するモード

このテスト用のモードは全てのモデルにおいて共通仕様です。

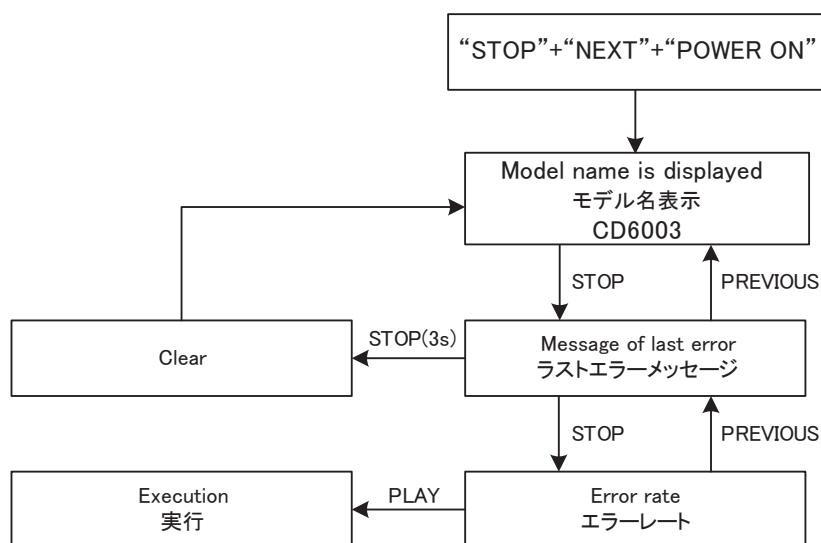

Here is the indication and specification of each function.

ここで、それぞれの表示及び仕様を示します。

1. Last Error Message

This function enables the users to check error messages at a later time when an error has occurred between the front microprocessor and each device.

However, it does not display all errors. For more information about what messages can be displayed, refer to the Other Error Message page.

When no error has ever occurred, it displays the following.



Hold the **STOP** button for 3 seconds while the last error message is being displayed, and the last error message will be cleared. After the last error message is cleared, the model identification returns to the display.

1. ラストエラーメッセージ

フロントマイコンと各デバイス間の通信エラーなどが生じた際のエラー表示を、後からでも確認できる機能です。但し、全てのエラー表示を記録するわけではありません。表示が可能なエラー情報はエラーメッセージの項を参照ください。

尚、エラー情報がない場合は、以下の表示を行います。

ラストエラーメッセージを表示中に、**STOP** キーを3秒間押し続けるとラストエラーメッセージ情報をクリアすることができます。このとき、ラストエラーメッセージ情報のクリアが完了するとモデル名表示に自動的に復帰します。

2. Error Rate

This function determines the CD error rate. When the disk that can be reproduced has been inserted, it displays it as follows. Here, the case where CD-DA has been inserted is indicated.



The measurement of the error rate of inserted disk and real machine begins when Play Key or remote controller's Play command is input while displaying the above-mentioned.

The error rate displays the sum total of the C1 error and the C2 error every one second with Hex.

2. エラーレート

CDのエラーレートを測定します。再生可能なディスクが挿入されていると以下の表示を行います。ここでは、CD-DAが挿入されている場合を示します。

上記表示中に Play Key 又はリモートコントローラーの Play コマンドが入力されると、挿入されたディスクと実機のエラーレートの測定を開始します。エラーレートは、1秒毎のC1エラー及びC2エラーの総和をHexで表示します。

The example of the display is for your information shown.

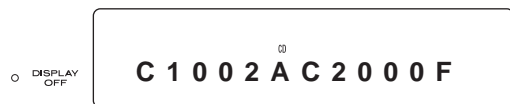

Four digits since C1 are the C1 errors. Four digits since C2 become the C2 errors. The buttons that function or command becomes Stop, Open/Close, Standby, Power, and Power Off while measuring it.

The buttons that function while this message is being displayed are OPEN/CLOSE and PLAY.

参考までに表示例を示します。

ここで、C1以降の4桁がC1エラーの値となり、C2以降の4桁がC2エラーの値となります。

測定中に有効なKey又はコマンドは、Stop、Open/Close、Standby、Power及びPower Offとなります。

この表示中に有効なキーはOPEN/CLOSEとPLAYになります。又、同じディスクを使用しても同じ値が出るとは限りません。

6. ALL CLEAR

To reset the back up memory of the unit into the default status, follow the procedure below.

However, information of the serial number and the reproduction time on the set cannot be deleted by this function. Connect the mains cord into the unit and press **STOP** and **POWER ON** button simultaneously more than 3 seconds.



"Reset" is displayed, after "Reset OK" displayed on the display 3 seconds, then unit returns to the normal status.



6. オールクリア

本機能を使用することで、工場出荷状態の設定に戻すことが可能です。但し、セットのシリアル番号及び再生時間情報に関しては本機能で消去することはできません。

STOP キーを押した状態で**POWER ON** キーを押します。Standby解除から3秒間**STOP** キーが押され続けるとオールクリアに移行します。オールクリアの状態に移行すると、以下の表示に変わります。

オールクリアの処理が完了すると以下の表示を3秒間表示し、通常状態の表示に復帰します。

7. ERROR MESSAGE

The error message common to all models.

[A] The error message displayed as the Last Error Message

1 Peculiar error information to CD module

1) Limit switch error of pick up

The CD module moves picking up to an inner side and the outer side when starting, and confirms whether the switch that exists in the CD module works normally. At this time, when the switch that provides for range of motion on an inner side of picking up doesn't work normally, the following errors are displayed.

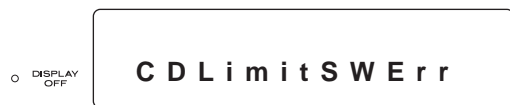

At this time, please confirm whether the tray open/close first pressing the **OPEN/CLOSE** button.

Please refer to "The tray do not Open/Close" when it is not possible open or close.

7. エラーメッセージ

全モデル共通のエラーメッセージ

[A] ラストエラーメッセージにて表示されるエラーメッセージ

1 CDモジュール単独のエラー情報

1) ピックアップのリミットスイッチエラー

CDモジュールは起動時にピックアップを内周側と外周側に移動して、CDモジュールにあるスイッチが正常に動作しているか確認を行います。この時、ピックアップの内周側の動作範囲を規定するスイッチが正常に動作していない場合、以下のエラーを表示します。

この時、まず**OPEN/CLOSE** キーを押してトレイがオープン/クローズするか確認してください。

オープン/クローズできない場合は、“トレイがOpen/Closeできない”を参照ください。

Confirm whether pick-up operates on a reception desk side and a rear side when opening/closing when a pertinent error is confirmed to can open/close.

Confirm each cable when it doesn't operate or the voltage of 1pin and 2pin of CN32 changes from 7.5V into about 4V. Confirm the solder of IC21 and CN32 when having changed. There is a possibility of the breakdown of the CD module when not having changed. Exchange CD modules.

2) Transfer error of boot program of CD DSP

The following error of three is divided in the software debug. It displays it to CD DSP when failing in writing the boot program. In this case, confirm the solder of IC31 of CUP12190x. If the same problem arises after confirmed, IC31 may be broken. If such is the case, replace IC31.

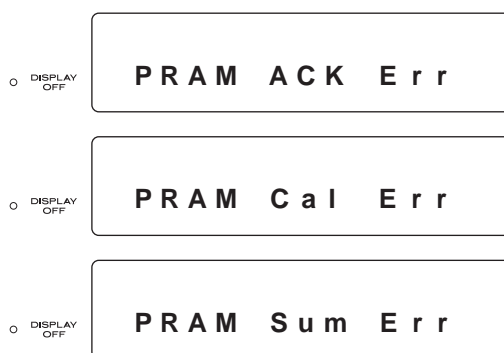

3) Error concerning discs

When the disk cannot be read by some reasons in the disk relation, the following displays are done. The condition, when it takes 60 seconds or more to read TOC of the disk and CD-DA not being done for the disk and write from be not shut session (CD-I) and the first session that focus doesn't encounter it that cannot be reproduced or it takes 120 seconds or more to analyze CD-ROM, it displays it.



When the acquisition of information that is called subcode Q data including information of TOC information and the reproduction time cannot be acquired longer than the fixed time, this display is displayed. There is a possibility that there are some problems on the disk side when a general disk can be reproduced, and only a specific disk is displayed. There is a possibility that IC31, IC32 or the CD module is out of order when the error of the correspondence occurs on not a specific disk but two or more disks.



オープン/クローズができるのに該当エラーが確認される場合は、オープン/クローズした際にピックアップ本体がフロント側及びリア側に動作しているか確認してください。

動作していない場合、CN32の1pin及び2pinの電圧が7.5Vから4V程度に変化する場合は、各ケーブルを確認してください。動作している場合は、CN32の6pinがトレイをクローズした際にHigh⇔Lowと変化するか確認してください。変化している場合はIC21及びCN32の半田を確認してください。変化していない場合、CDモジュールの故障の可能性あります。CDモジュールを交換してください。

2) CD DSPのブートプログラムの転送エラー

下記の3つのエラーに関しては、ソフトウェアのデバック上分けていますが、CD DSPへブートプログラムの書き込みに失敗した場合には表示を行います。この場合、CUP12190xのIC31の半田を確認してください。

確認後も同様のエラーが表示される場合、IC31の故障の可能性あります。IC31を交換してください。

3) ディスク関連のエラー

ディスク関連で、何らかの理由でディスクが読めない場合以下の表示を行います。

条件的には、フォーカスが合わない、再生不可能なセッション(CD-I)、最初のセッションが閉じられていないディスク、書き込みがされていないディスク、CD-DAのTOCの読み込みに60秒以上かかる場合、CD-ROMの解析に120秒以上かかる場合に表示を行います。

この表示は、TOC情報や再生時間情報を含むサブコードQデータと呼ばれる情報の取得が一定時間以上取得できなかった場合に表示されます。

一般のディスクが再生できていて、特定のディスクのみ表示される場合はディスク側に何らかの問題がある可能性があります。

特定のディスクではなく複数のディスクで該当のエラーが発生する場合、IC31、IC32又はCDモジュールが故障している可能性があります。CDモジュールを交換してみても該当エラーが発生する場合はIC31又はIC32を交換してください。

When the error is continuously caused five times or more, two or more errors do the following display by internal processing. There is a possibility that IC31, IC32 or the CD module is out of order when the error of the correspondence occurs on not a specific disk but two or more disks. Exchange IC31 or IC32 when a pertinent error occurs even if CD modules are exchanged.

内部処理で複数のエラーが連続で5回以上エラーが生じた場合に下記の表示を行います。

特定のディスクではなく複数のディスクで該当のエラーが発生する場合、IC31、IC32又はCDモジュールが故障している可能性があります。

CDモジュールを交換してみても該当エラーが発生する場合はIC31又はIC32を交換してください。



4) Communication Error between D/A Converter and Front Microprocessor

If no response is detected in the communication between the D/A Converter and the Microprocessor, the display will show the following message.

Check that the flexible cable has been duly connected between CUP12190x and CUP12192x and also that L752(+5V) and IC75(14pin(+3.3V)) on the CUP12192x are receiving the designated voltage.

Make the CD or the USB repayable.

Ensure that IIC communications have been established between R755 and R756 when the unit is switched from STOP to PLAY.

If the error cannot be corrected through normal operations, IC75 may be broken. If such is the case, replace IC75.

4) D/A コンバータとマイコンとの通信エラー

D/A コンバータとマイコンの通信において指定時間内に応答がない場合、以下の表示を行います。

CUP12190xとCUP12192xを接続しているケーブルがきちんと接続されているか確認してください。

CUP12192x上のL752(+5V)とIC75の14pin(+3.3V)を確認し、指定の電圧が確認してください。

CD又はUSBを再生可能な状態にしてください。

Stop状態からPlay状態に変更するときにR755とR756にIIC通信が行われているか確認してください。

通常動作が行われている状態で、当エラーが解消できない場合、IC75が壊れている可能性があります。IC75を交換してください。



5) iPod-authenticated error and the microprocessor communication error

If no response is made in the communication with an iPod-authenticated IC within a regulated timeframe, the display will show the following message.

As the communication with the authenticated IC has not been established normally, ensure that the IIC signal is communicating at a normal level when the unit is connected with an iPod.

The frequency of the IIC clock (IIC_SCL) is approximately 40 kHz only when the unit communicates with an iPod-authenticated IC. If no communication can be detected, check the soldering points of the microprocessor (IC21 on CUP12190x), resistors (R214, R215, R217 and R218 on CUP12190x) and the authenticated IC (R214 on CUP12190x).

If the problem specific to the iPod cannot be rectified, the authenticated IC (IC27 on CUP12190x) may be broken.

If that is the case, replace IC27.

5) iPodの認証ICとマイコンの通信エラー

iPodの認証ICとの通信において指定時間内に応答がない場合、以下の表示を行います。

認証ICとの通信が正常に行われていない状態なので、iPodを接続したときにIICの信号が正常なレベルで通信しているか確認してください。

尚、iPodの認証ICとの通信を行うときのみIICのクロック (IPOD_SCL) は約40kHzになります。通信が行われていないようであれば、マイコン (CUP12190x上のIC21)、抵抗 (CUP12190x上のR214、R215、R217、R218)、認証IC (CUP12190x上のIC27) の半田付けの状態を確認してください。

通常動作が問題なくiPodのみ的问题が解決できない場合は、認証IC (CUP12190x上のIC27) が壊れている可能性があります。IC27を交換してください。



6) Other errors of iPod-authenticated error

When the iPod-authenticated IC has received error information, the display will show the following message. This message means that the authenticated IC is communicating properly. Try connecting another iPod. If no problem arises with another iPod, advise the user to repair the iPod.

If the same problem arises with another iPod, the authenticated IC (IC27 on CUP12190x) may be broken. If that is the case, replace IC27.



When a problem arises with the processing of the iPod authentication and signature, the display will show the following message.

If the following message appears instead of the above messages - "iPodErrorIC", "iPodICErrorx" and "USB_Com_Error_", try connecting another iPod.

If no problem arises, advise the user to repair the iPod.

If the error message persists, the authenticated IC (IC27 on CUP12190x) may be broken. If that is the case, replace IC27.



2 Error Messages special to USB device

If no response is made in the communication between the USB Module and the microprocessor within a designated timeframe, the display will show the following message.

Ensure that each of L161, L251, L252 and L181 on CUP12190x is applied with the voltage.

Ensure that each of 1pin and 50pin in IC11 on CUP12190x is supplied with the clock signal of the designated frequency.

Check the soldering points of IC21, IC11 and around.

Refer to the Communication between USB Module and the microprocessor on the Communication Waveform page and check the signal.

If the error message below cannot be cleared despite the unit performing normal operations properly, IC11 may be broken. If such is the case, replace IC11.



6) 認証ICのその他のエラー

iPodの認証IC上で確認できる認証エラーの情報を受け取ると以下の表示を行います。

この表示の場合、認証ICとの通信は正常に行われているので、他のiPodを接続してみてください。

他のiPodを接続して問題がないようであれば、iPod側の修理をするよう勧めてください。

他のiPodでも同様のエラー表示が出る場合、認証IC(CUP12190x上のIC27)が壊れている可能性があります。IC27を交換してください。

iPodの認証及び署名に関する処理に問題が発生すると、以下の表示を行います。

上の“iPodErrorIC”、“iPodICErrorx”及び“USB_Com_Error_”が表示されなくて以下の表示がされる場合、他のiPodを接続してみてください。

他のiPodを接続して問題がないようであれば、iPod側の修理をするよう勧めてください。

他のiPodでも同様のエラー表示が出る場合、認証IC(CUP12190x上のIC27)が壊れている可能性があります。IC27を交換してください。

2 USBデバイス単独のエラー情報

USBデバイスとマイコンの通信において指定時間内に応答がない場合、以下の表示を行います。

CUP12190xのL161、L251、L252及びL181にそれぞれの電圧が印加されているか確認してください。

CUP12190xのIC11の1pin及び50pinに所定の周波数のクロック信号が見えるか確認してください。

IC21とIC11及び周辺回路の半田付けの状態を確認してください。

通信波形の項にあるUSBデバイスとマイコンとの通信を参照し、その信号を確認してください。

通常動作が問題なく下記エラーメッセージが解消できない場合は、IC11が壊れている可能性があります。IC11を交換してください。

[B] Error messages that are not displayed in the Last Error Message

1 Error messages that can be displayed on the FL or LCD

1) Communication Error between the Front Microprocessor and EEPROM

If no response is detected between the Front Microprocessor and EEPROM within a regulated timeframe, the display will show the following message.

Ensure that IIC communications have been established between R235 and R236 on CUP12190x when the unit is powered on or put into STANDBY.

If no communication is detected, check the soldering of R212, R213, R235, R236, IC21 and IC22.

If the error cannot be corrected through normal operations, IC22 may be broke. If such is the case, replace IC22.



2) Error Messages special to USB

If no response is made while the unit is communicating with the USB Module, the display will show the following message.

If the indication will not be changed to "USB_Com_Err", the communication may be unstable. Check if the regulated voltage is applied to each of L161, L251 and L252 on CUP12190x.

Check if 1pin and 50pin in IC11 on CUP12190x receive the clock signal of the designated frequency

Check the soldering points of IC21, IC11 and around.

Refer to the communication between the USB module and the microprocessor on the communication waveform page and check the signal. If the message below cannot be cleared while the unit is functioning normally, IC11 may be broken. If that is the case, replace IC11.



When the unit is connected with an incompatible USB device or a device configured with an incompatible communication protocol or command, the display will show the following message.

If this message is displayed, the device is incompatible and cannot be connected to the unit.



If the information obtained from the USB has a flaw or improper data, which are detected by the USB host controller in the unit, the display will show the following message.

[B] ラストエラーメッセージにて表示されないエラーメッセージ

1 FL 又は LCD 上に表示可能なエラーメッセージ

1) マイコンとEEPROMとの通信エラー

EEPROMとマイコンの通信において指定時間内に応答がない場合、以下の表示を行います。

電源投入時又はスタンバイ移行時に、CUP12190xのR235とR236にIIC通信が行われているか確認してください。

通信が行われていない場合、R212、R213、R235、R236、IC21、IC22の半田の状態を確認してください。

通常動作が行われている状態で、当エラーが解消できない場合、IC22が壊れている可能性があります。

IC22を交換してください。

2) USB 単独のエラー情報

USBデバイスに通信を行った際に、USBデバイスから返答がない場合、以下の表示を行います。

"USB_Com_Err"に移行しない場合、通信が不安定になっている可能性があります。

CUP12190xのL161、L251、L252及びL181にそれぞれの電圧が印加されているか確認してください。

CUP12190xのIC11の1pin及び50pinに所定の周波数のクロック信号が見えるか確認してください。

IC21とIC11及び周辺回路の半田付けの状態を確認してください。

通信波形の項にあるUSBデバイスとマイコンとの通信を参照し、その信号を確認してください。

通常動作が問題なく下記エラーメッセージが解消できない場合は、IC11が壊れている可能性があります。IC11を交換してください。

接続されたUSB機器が対象外のもの(例えばUSBキーボードなど)や、本機で対応できない通信プロトコルやコマンドを使用している機器が接続された場合、以下の表示を行います。

本表示が行われた機器は、本機対象外の機器のため接続はできません。

接続されたUSBから取得した情報に不具合や不正なデータがある場合、通信のタイムアウト及び本機で使用しているUSBのホストコントローラーがエラーを検出すると以下の表示を行います。

When the message appears, the device may be connected and used, but success is not guaranteed.

この表示が行われた機器に関しては、場合によっては接続ができるかもしれませんが、接続に関しては、保障するものではありません。

○ DISPLAY OFF

C o n n e c t E r r o r

If the signal comes in an incompatible format, the display will show the following message.

The compatible formats are FAT16 and FAT32. In FAT32 the USB memory must be 128MB or bigger in size.

Moreover, it doesn't correspond to the file system for usual Mac OS when formatting it with Mac OS of the Apple Co.. Please format it with FAT32. (OS supports it up to 32GB or less.)

本機で対応できない規格でフォーマットされている場合、以下の表示を行います。

本機で対応可能なファイルフォーマットは、**FAT16**又は**FAT32**になります。但し、**FAT32**の場合**128MB**より大きな**USBメモリ**に限ります。又、Apple社の**Mac OS**でフォーマットする場合は、通常の**Mac OS**用のファイルシステムには対応していません。**FAT32**でフォーマットするようにしてください。(最大**32GB**までOSがサポートしています。)

○ DISPLAY OFF

F A T E r r o r

This message means that the device is formatted in an incompatible cluster size. Normally, when USB memories are formatted on Microsoft Windows, FAT32 is the default, and if the memory size is up to 128MB, it will be formatted in a cluster size of 2KB, which is incompatible with the unit. Therefore, the memory size is recommended to be 256MB or bigger. If the memory size is 128MB, format it with FAT16 (indicated as FAT on Microsoft Windows) instead of FAT32, and it will be compatible with the unit.

本機で対応できないクラスタサイズでフォーマットされています。通常**Microsoft Windows**で**USBメモリ**等をフォーマットする場合、**FAT32**がデフォルト設定になっています。そのため、**128MB**までのサイズのメモリの場合、本機で対応できない**2kB**のクラスタを使用してフォーマットされてしまいます。よって、**256MB**以上のメモリを推奨しています。**128MB**の**USBメモリ**を使用する場合、**FAT32**でフォーマットするのではなく**FAT16**(**Microsoft Windows**上では**FAT**と表記されます)でフォーマットすると、本機で使うことができるようになります。

○ DISPLAY OFF

C l u s t e r E r r

If the unit receives a power supply exceeding the maximum level (500 mA) via USB, the display will show the following message and the power supply will be cut off. If the message below appears, the USB device cannot be operated through the unit's USB Bus power alone. An auxiliary power unit might enable the device to be used, but damage resulting from this would not be covered by the warranty.

USBを介して本機で供給可能な電流値の制限(**500mA**)を超えた場合、以下の表示を行い、電源供給を中止します。この表示が現れる機器を本機のみ**USBバスパワー**で動作することはできません。補助電源にて供給可能な**USBデバイス**の場合は使用できる場合もありますが、本機での動作保障外となります。

○ DISPLAY OFF

O v e r C u r r e n t

If the command will not be set within a set timeframe after PLAY, PAUSE, STOP, FF, FR and such operations are carried out, the display will show the following message.

This message will be displayed for 3 seconds and then the USB module will be reset.

If the error indication persists after these operations, IC11 may be broken as the unit will not accept a specific command alone. If no other error message will appear, replace IC11.

USBデバイスに対してファイルの再生、一時停止、停止、早送り、早戻しといった操作を行った際に、一定時間たってもコマンド設定が行われない場合に、以下の表示を行います。この表示に関しては、**3秒間**表示した後**USBデバイス**に対してリセットをかけます。

同様の動作を行ってもエラー表示が現れる場合、特定コマンドのみ受け付けていないため**IC11**が壊れている可能性があります。他のエラー表示が確認できない場合、**IC11**を交換してください。

○ DISPLAY OFF

U S B T i m e O u t

If the file has an incompatible extension or is 24KB or smaller in size, the display will show the following message.

Extensions other than those mentioned in the instructions manual will be excluded from the warranty. Refer to the instructions manual and ensure that the extension and format is compatible with the unit.



本機で再生できない拡張子のファイルや24kB以下のファイルの場合、以下の表示を行います。

取扱説明書に記載されている拡張子以外は、対象外又は保障外となります。

取扱説明書に記載されている拡張子で対象フォーマットのファイルを利用してください。

If the unit detects an incompatible sampling frequency or number of channels or an incompatible format file, the display will show the following message.

Sampling frequencies, numbers of channels and formats other than those mentioned in the instructions manual will be excluded from the warranty. Refer to the instructions manual and ensure that the format is incompatible.



本機で再生できないサンプリング周波数やチャンネル数、未対応のフォーマットのファイルを検出すると以下の表示を行います。

取扱説明書に記載されているサンプリング周波数、チャンネル数及び対応フォーマット以外は、対象外又は保障外となります。取扱説明書に記載されている対象フォーマットのファイルを利用してください。

If the file includes big sized image data or information, the analysis may take time. If the analysis takes more than 15 seconds, the display will show the following message.

If this message appears, the operation of the file will not be covered by the warranty.



サイズの大きな画像データや情報が付加されている場合、その情報の解析に時間がかかることがあります。

本機では、解析時間が15秒以上かかる場合に以下の表示を行います。この表示がでるファイルの再生に関しては、保障外となります。

If the USB module turns off the command for the settings of AMS, Repeat or Random, the display will show the following message.

If the error persists after the mode is switched to Disc from USB and then reswitched to USB and the designated remote control code is sent, IC11 may be broken as it will not accept a specific command alone. If no other error message appears, replace IC11.



AMS設定、Repeat設定、ランダム設定等の要求に対してUSBデバイスがコマンドを無効と処理した場合、以下の表示を行います。

一旦USBモードからDiscモードに切り替えた後、再度USBモードに戻して、該当のリモコンコードを送付しても同様のエラーが出る場合、特定コマンドのみ受け付けていないためIC11が壊れている可能性があります。他のエラー表示が確認できない場合、IC11を交換してください。

If the USB module turns off the command for setting AMS, Repeat or Random and specifying the range, the display will show the following message.

If the error persists after the mode is switched to Disc from USB and then reswitched to USB and the designated remote control code is sent, IC11 may be broken as it will not accept a specific command alone. If no other error message appears, replace IC11.



AMS設定、Repeat設定、ランダム設定等の要求に対してUSBデバイスが各動作を行う範囲指定に対して無効と処理した場合、以下の表示を行います。

一旦USBモードからDiscモードに切り替えた後、再度USBモードに戻して、該当のリモコンコードを送付しても同様のエラーが出る場合、特定コマンドのみ受け付けていないためIC11が壊れている可能性があります。他のエラー表示が確認できない場合、IC11を交換してください。

When the unit has failed to search for a folder or a file, obtain folder information or set the default, the display will show the following message.

If this error repeats, IC11 may be broken. If that is the case, replace IC11.



フォルダ及びファイルの検索、フォルダの情報の取得、デフォルト設定時等に失敗した際に、以下の表示を行います。何度もこのエラーが確認される場合、IC11が壊れている可能性があります。IC11を交換してください。

If the unit has failed to obtain information of the file to be played back, the display will show the following message.

If this error occurs to a specific file, the file information may be corrupted. Check the file header and other information.

If the error occurs to all files, IC11 may be broken. If no other error message appears, replace IC11.



再生対象ファイルの情報の取得に失敗すると以下の表示を行います。

特定のファイルでこのエラーが確認される場合、そのファイルの情報が壊れている可能性があります。

ファイルのヘッダ情報等を確認してください。

全てのファイルに対してこのエラーが確認される場合、IC11が壊れている可能性があります。他のエラー表示が確認できない場合、IC11を交換してください。

If the unit has failed to obtain information of the SB manufacturer, the product and the serial number, the display will show the following message.

On the display, the "x" will be replaced by the number 1, 2 or Failed to obtain manufacturer information; 2. Failed to obtain product information; 3. Failed to obtain serial number.

If this message appears, use of the device will not be covered by the warranty.



USBの製造者情報、製品情報及びシリアル情報の取得に失敗すると、以下の表示を行います。

表示上の"x"は、1～3の数字が表示され、1:製造者情報の取得に失敗、2:製品情報の取得に失敗、3:シリアル番号の取得に失敗を示します。

本表示が現われた機器は、本機で接続及び動作を保障するものではありません。

If the unit has failed to set a decodable file, the display will show the following message.

If the error persists after the mode is switched to Disc from USB and then reswitched to USB and the designated remote control code is sent, IC11 may be broken as it will not accept a specific command alone. If no other error message appears, replace IC11.



本機でデコード可能なファイルの設定に失敗すると、以下の表示を行います。

一旦USBモードからDiscモードに切り替えた後、再度USBモードに戻しても同様のエラーが出る場合、特定コマンドのみ受け付けていないためIC11が壊れている可能性があります。他のエラー表示が確認できない場合、IC11を交換してください。

If the unit has failed to set a Logic Unit Number for a USB device connected thereto, the display will show the following message. Currently, the program already has a prepared function, which is not used for SA8003 and hence will never be displayed.



接続されたUSB機器のLogic Unit Numberを指定する際に、設定に失敗すると以下の表示を行います。

現状、プログラムの関数としては準備していますが、CD6003では使用していないため表示されることはありません。

3) Common error information on CD and USB device

If the unit detects a DRM protected file, the display will show the following message.

The unit is not made to and hence cannot play back DRM protected files.



If the unit detects a file with corrupted file data or other unacceptable files, the display will show the following message.

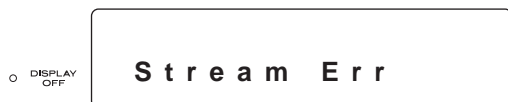

If no playable file exists in the USB device connected to the unit, the display will show the following message:



4) Error Message that can be displayed while an iPod device is connected

If the unit experiences an error in the recognition process or fails to receive required information from an iPod device, the display will show the following message.

If this error has occurred, try unplugging and plugging the device again. If the same message is displayed again, try another iPod device.

If the unit works normally with another iPod, advise the user to repair the iPod device.

However, the firmware version that can be connected with this machine exists for 1G, 2G Nano, and 5G iPod. It becomes the following error display for the firmware version that cannot be connected. Please use the latest firmware.



If an error occurs to communication commands in the recognition process, the display will show the following message. This message is mainly for debugging software and normally does not appear.

The display shows this message for only 3 seconds and then changes to "Can'tConnect".



If the unit has failed to receive response from the iPod device within a given timeframe for the processing, the display will show the following message.

3) CD及びUSBデバイスの共通のエラー情報

デジタル著作権管理されているファイルを検出すると、以下の表示を行います。

デジタル著作権管理されているファイルに対しては、本機は未対応ですので再生することができません。

再生しようとするファイルの情報の一部が破損されているなど、本機で再生できないファイルを検出すると以下の表示を行います。

挿入されたディスク又は接続されたUSBデバイス上に本機で再生可能なファイルが存在しない場合、以下の表示を行います。

4) iPodを使用した際に表示されるエラーメッセージ

認証処理中に認証エラーが発生する又はiPodへ要求した情報の返答が来ないなど接続を行う上で障害が生じた際、以下の表示を行います。

一旦iPodをCD6003から抜いて再度接続を試みてください。それでも以下の表示が出る場合、他のiPodの接続を試みてください。

他のiPodにて接続に問題がない場合、iPod側の修理をすよう勧めてください。

但し、1G及び2G Nanoと5G iPodの場合、本機との接続が可能なファームウェアバージョンが存在します。接続できないファームウェアバージョンの場合は、下記エラー表示となります。最新のファームウェアを使用するようにしてください。

認証処理段階で通信するコマンド等のエラーが起きると以下の表示を行います。

このエラー表示は主にソフトウェアデバッグ用ですので、通常表示されることはありません。

尚、このエラー表示は3秒間だけ表示され、その後“Can'tConnect”表示に移行します。

iPodより指定された処理時間を経過してもiPodより返答がない場合に以下の表示を行います。

If no error occurs with another iPod device, advise the user to repair the iPod device.

This message is displayed for 3 seconds only and then changes to "Can't Connect".



If the unit fails to receive response from the iPod device within a given period of time after sending a command, the display will show the following message.

If no error occurs with another iPod device, advise the user to repair the iPod device.

This message is displayed for only 3 seconds and then changes to "Can't Connect".



If an error occurs to communication commands while the unit is performing normal operations excluding such basic ones as PLAY, PAUSE and SEARCH, the display will show the following message.

This message is mainly for debugging software and normally does not appear.

After this message is displayed, the unit automatically resets the USB module. If the error persists after the unit is restarted, IC11 may be broken as it will not accept a specific command alone. If no other error message appears, replace IC11.



If an error occurs to communication commands while the unit is performing normal operations including PLAY, PAUSE and SEARCH, the display will show the following message. This message is mainly for debugging software and normally does not appear.

After this message is displayed, the unit automatically resets the USB module. If the error persists after the unit is restarted, IC11 may be broken as it will not accept a specific command alone. If no other error message appears, replace IC11.



If an error occurs to the command communication to indicate a change in the sampling frequency, the display will show the following message. This message is mainly for debugging software and normally does not appear.



他の iPod にて接続に問題がない場合、iPod 側の修理をするよう勧めてください。

尚、このエラー表示は3秒間だけ表示され、その後 "Can't Connect" 表示に移行します。

iPod に対してコマンドを送付し、一定時間返答がない場合以下の表示を行います。

他の iPod にて接続に問題がない場合、iPod 側の修理をするよう勧めてください。

尚、このエラー表示は3秒間だけ表示され、その後 "Can't Connect" 表示に移行します。

再生・一時停止・サーチ等の基本動作を除く通常動作中に通信するコマンド等のエラーが起きると以下の表示を行います。

このエラー表示は主にソフトウェアデバッグ用ですので、通常表示されることはありません。

この表示を行った後、自動的に USB デバイスのリセットを行います。再起動後も同様のエラーが出る場合、特定コマンドのみ受け付けていないため IC11 が壊れている可能性があります。他のエラー表示が確認できない場合、IC11 を交換してください。

再生・一時停止・サーチ等の通常動作中に通信するコマンド等のエラーが起きると以下の表示を行います。

このエラー表示は主にソフトウェアデバッグ用ですので、通常表示されることはありません。

この表示を行った後、自動的に USB デバイスのリセットを行います。再起動後も同様のエラーが出る場合、特定コマンドのみ受け付けていないため IC11 が壊れている可能性があります。他のエラー表示が確認できない場合、IC11 を交換してください。

iPod 上のファイルのサンプリング周波数などが変化したことなどを通知するコマンドの通信においてエラーが起きると以下の表示を行います。

このエラー表示は主にソフトウェアデバッグ用ですので、通常表示されることはありません。

Upon confirming that an iPod device is connected, the unit will begin modifying the USB communication method. If an error occurs in this process, the display will show the following message.

If this message reappears after unplugging and plugging the iPod device, IC11 may be broken as it will not accept a specific command alone.

If no other error message appears, replace IC11.



The following error displays are done when "Direct" has been selected as a method of controlling iPod when 1G Nano and 5G iPod are used and it operates automatically as "Remote". The purpose of this is for above-mentioned iPod not to be able to output the voice in the "Direct" mode. When corresponding iPod is used, we will recommend "Remote" to be selected.

iPodが接続されたことが確認できるとUSBの通信方式の変更を開始します。

この際、変更に何らかの不具合が生じると以下の表示を行います。

iPodを抜き差ししてもこの表示が出る場合、特定コマンドのみ受け付けていないためIC11が壊れている可能性があります。他のエラー表示が確認できない場合、IC11を交換してください。

1G Nano及び5G iPodを使用する際、iPodのコントロール方法として"Direct"を選択されている場合、以下のエラー表示が行われて自動的に"Remote"として動作します。これは、上記iPodが"Direct"モードで音声出力ができないためです。該当するiPodを使用される場合は、"Remote"を選択することをお勧めします。

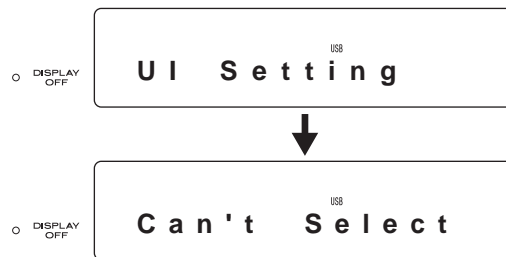

2 Error Messages that Cannot Be Displayed on the FL and LCD

1) Display Off LED flickering

After the primary source is powered on, the microprocessor in the unit will obtain model information.

Until this setting is confirmed, the unit cannot show any messages on the display/.

In this case, check if 98pin and 99pin on CUP12190x receive designated voltages.

2 FL及びLCD上にて表示できないエラーメッセージ

1) Display off LED が点滅する

一次電源投入後、本セットのマイコンはモデル情報の取得を行います。

この設定が不定の場合、Display Off LEDが点滅し、表示が行われません。

CUP12190x上のIC21の98pin及び99pinが指定の電圧かどうか確認してください。

IC21	Signal name	CD6003
98pin	MODELSEL0	0V~1.1V
99pin	MODEL_SEL1	0V~1.1V

If the unit receives the regulated voltage and yet has the Display Off LED flickering, IC21 on CUP12190x may be broken. If such is the case, replace IC21

Check the signal in reference to Communications between the FL and the Microprocessor on the Communication Waveform page.

All signals are output from the Microprocessor.

If no signal is output, IC21 on CUP12190x may be broken. If such is the case, replace IC21.

If a signal is detected, FL51 may be broken. If such is the case, replace FL51.

電圧に問題がなくDisplay Off LEDが点滅している場合、CUP12190x上のIC21が壊れている可能性があります。IC21を交換してください。

一次電源を再度投入すれば、FLとマイコンの通信が行われます。

通信波形の項にあるFLとマイコンとの通信を参照し、その信号を確認してください。

全ての信号はマイコンから出力されます。

Display Off LEDが点滅されていないのに信号が出力されていない場合、CUP12190x上のIC21が壊れている可能性があります。IC21を交換してください。

信号が確認された場合、FL51が壊れている可能性があります。FL51を交換してください。

2) Remote controller doesn't work.

Confirm the switch of EXTERNAL/INTERNAL is INTERNAL. Confirm the shape of waves of 5V amplitude has gone out of 1pin of RS51 on CUP12191x-1 when the command is input from a remote controller.

Confirm the shape of waves of 3.3V amplitude has gone out when the command is input from a remote controller to 35pin of IC21 of CUP12190x. The solder of IC21 is confirmed, and there is still a possibility that IC21 is broken when it is not possible to repair when going out. Exchange IC21.

The case of No signal appear then check Q402, D401 and around.

3) Tray doesn't work

Confirm the voltage of 1pin of 1pin of IC32 of CUP12190x, 3pin, and CN31 and 2pin when the tray doesn't work. Confirm the connection of each cable when the voltage of about 3V is output to 1pin of IC32 or 2pin of CN31 when 1pin of 3pin or CN31 of IC32 is closed when opening.

Confirm whether 9pin of IC21 or 33pin of IC32 is High after pushing the **OPEN/CLOSE** key when the voltage is not confirmed.

Confirm soldering Q302, Q303, and IC32 when 33pin of IC32 doesn't become High.

There is a possibility that IC32 is broken when it is time when it is High 33pin of IC32, and it is not output to 1pin etc. of IC32. Please exchange it. There is a possibility that the CD module is out of order when the tray is not good at Open/Close even if all work is done. Please exchange it.

2) リモートコントローラーの受信ができない

EXTERNAL/INTERNALのスイッチがINTERNALになっていることを確認してください。

リモートコントローラーからコマンドを入力した場合にCUP12191x-1上のRS51の1pinから5V振幅の波形が出ていることを確認してください。

CUP12190xのIC21の35pinに、リモートコントローラーからコマンドを入力した場合に3.3V振幅の波形が出ていることを確認してください。

出ている場合は、IC21の半田を確認し、それでも修理できない場合IC21が壊れている可能性があります。IC21を交換してください。

出していない場合は、Q402及びD401を含む周辺回路を確認してください。

3) トレイがOpen/Closeできない

トレイが動作しない場合は、CUP12190xのIC32の1pin及び3pin、CN31の1pin及び2pinの電圧を確認してください。オープン時にIC32の3pin又はCN31の1pin、クローズ時にIC32の1pin又はCN31の2pinに約3Vの電圧が出力されている場合は、各ケーブルの接続を確認してください。電圧が確認されない場合は、**OPEN/CLOSE**キーを押した後にIC21の9pin又はIC32の33pinがHighになっているか確認してください。

IC32の33pinがHighにならない場合は、Q302及びQ303とIC32の半田付けを確認してください。

IC32の33pinがHighになっている場合で、IC32の1pin等に出力されない場合はIC32が壊れている可能性があります。交換してください。

全ての作業を行ってもトレイがOpen/Closeできない場合はCDモジュールが故障している可能性があります。交換してください。

8. TROUBLESHOOTING

8.1 Discs cannot be played back

[A] An Message is displayed

Refer to "ERROR MESSAGE"

[B] No Error Message

1) Either CDs or SA-CDs cannot be played back

In this case, OPU may have been crippled due to deterioration of the CD laser. Replace the Traverse and ensure that the Playtime is cleared.

2) Neither Disc can be played back

In this case, either the pickup mechanism or the decoder PCB may be broken.

Normally, if the front Microprocessor is communicating, the OPU may have been crippled due to deterioration of the CD laser. Replace the Traverse.

If the unit still will not play back discs, the decoder PCB may be having trouble. If such is the case, replace the decoder PCB and ensure that the Playtime is cleared.

8.2 No Audio

[A] Error Message Appears

Refer to "ERROR MESSAGE".

[B] No Error Message

1) No Audio in CD/CD-ROM

Compare the communication between IC31/IC12 on CUP12190x and IC75 on CUP12192x-2. IC12 is the selector to switch the signals.

If each module is communicating with IC31 and IC12 on CUP12190x without IC12 and IC75 of CUP12192x-2 communicating, IC12 may be broken, If such is the case, replace IC12.

If playing time display without IC31 and IC12 communicating, IC31 may be broken, If such is the case, replace IC31.

8.3 No Audio in USB

Compare the communication between IC11/IC12 on CUP12190x and IC75 on CUP12192x-2. IC12 is the selector to switch the signals.

If each module is communicating with IC11 and IC12 on CUP12190x without IC12 and IC75 of CUP12192x-2 communicating, IC12 may be broken, If such is the case, replace IC12.

If playing time display without IC11 and IC12 communicating, IC11 may be broken, If such is the case, replace IC11.

8. トラブルシューティング

8.1 ディスクが再生できない

[A] エラー表示あり

各エラー表示の項を参照ください

[B] エラー表示なし

1) CD-DA 又は CD-ROM ディスクが再生できない

この場合、CD用のレーザーの劣化等によるOPUの不具合の可能性があります。ピックアップメカ側を交換してください。この時、必ず再生時間クリアを行ってください。

2) 両方のディスクが再生できない

この場合、ピックアップメカ、デコーダー基板のどちらかが壊れている可能性があります。

通常、フロントマイコンと正常に通信を行っている場合、レーザーの劣化等によるOPUの不具合の可能性の方が高いです。ピックアップメカ側を交換してください。

それでも回らない場合は、デコーダー基板の不具合が考えられます。デコーダー基板を交換してください。

尚、ピックアップメカを交換した場合は必ず再生時間クリアを行ってください。

8.2 音が出ない

[A] エラー表示あり

各エラー表示の項を参照ください。

[B] エラー表示なし

1) CD/CD-ROM で音が出ない

CUP12190xのIC31とIC12の通信と、CUP12192x-2のIC75との通信を比べてみてください。IC12は各信号を切り替えるセレクターです。

CUP12190xのIC31とのIC12の通信がきているのに、IC12とCUP12192x-2のIC75の通信が行われていない場合、IC12が壊れている可能性があります。IC12を交換してください。

フロントの時間表示がカウントされているのにIC31とのIC12の通信が行われない場合は、IC31が壊れている可能性があります。IC31を交換してください。

8.3 USB で音が出ない

CUP12190xのIC11とのIC12の通信と、IC12とCUP12192x-2のIC75との通信を比べてみてください。IC12は各信号を切り替えるセレクターです。

CUP12190xのIC11とのIC12の通信がきているのに、IC12とCUP12192x-2のIC75の通信が行われていない場合、IC12が壊れている可能性があります。IC12を交換してください。

フロントの時間表示がカウントされているのにIC11とのIC12の通信が行われない場合は、IC11が壊れている可能性があります。IC11を交換してください。

8.4 Always No Audio

If no problem is found with the communications between each Module and IC75 on CUP12192x-2, the problem lies with IC75 or the following analog circuit. If the output of AOUTA+/- and AOUTB+/- of IC75 has not gone out, IC75 may be broken. If such is the case, replace IC75. Refer to each circuit.

8.5 USB device is not recognized

If the USB indication will not change after a USB device is connected, the unit has not recognized the USB device. If it still will not change after another USB device is tried, check if TPF691 is receiving a voltage of +5V.

Many devices are supplied with power through the USB port.

The USB indication means that the microprocessor is communicating with the USB module properly.

If the voltage cannot be detected, check 1pin of JK51, VDD of board and IC26. If the voltage is detected and yet going low on 2pin/3pin of JK51 after a USB device is connected, the USB module determines that no connection is made. If this is happening, the problem can lie with the USB device that has been connected thereto or with the USB connector.

If a wave is detected from TPF671 and TPF673 after a USB device is connected, IC11 may be broken. If such is the case, replace IC11.

8.6 The unit will not come out of STANDBY

If the unit will not come out of STANDBY after the POWER ON/STANDBY button is pressed while the STANDBY LED is flickering, check 59pin of IC21 on CUP12190x.

If this test pin has turned High, IC21 is functioning properly. Check CUP12192x-1.

If this test pin will not change from Low, IC21 may be broken. If such is the case, replace IC21.

8.4 常に音が出ない

CUP12192x-2のIC75まで通信が行われていて、各電源が正常に供給されている場合、IC75又はアナログ回路が故障している可能性があります。

IC75のAOUTA+/-及びAOUTB+/-の出力が出ていなければIC75が壊れている可能性があります。IC75を交換してください。

その他の場合はアナログ回路が壊れているか、ミュート回路が常にミュートしている場合です。各回路を参照ください。

8.5 USB デバイスが認識しない

USBデバイスを挿入したのに表示が“USB”から変化しない場合、USBデバイスを認識していません。

他のUSBデバイスを挿入しても同様な状態であれば、JK51の1pinに+5Vの電圧がきているか確認してください。多くのUSBデバイスは、USBポートから電源の供給を受けていることがあります。

又、“USB”の表示が行われている場合、マイコンとUSBデバイスの通信は正常に行われていることとなります。

電圧の確認ができない場合、JK51の1pinを始め、各基板上のVDD及びIC26を確認してください。

電圧の確認ができた場合、USBデバイスを挿入してもJK51の2pin/3pinが共にLowの場合、USBデバイスは未接続と認識します。

この場合、接続しているUSBデバイス側の問題又はUSBコネクタ(JK51)が考えられます。

USBデバイスを接続するとJK51の2pin/3pinに波形が確認できた場合、IC11が壊れている可能性があります。

IC11を交換してください。

8.6 スタンバイからの復帰ができない

スタンバイLEDが点灯している状態から、Power On/Standby Keyを押しても通常状態に復帰しない場合、CUP12190xのIC21の59pinを確認してください。

このテストピンがHighに変化している場合、IC21は正常に動作をしています。

CUP12192x-1を確認してください。

このテストピンがLowから変化しない場合は、IC21が壊れている可能性があります。

IC21を交換してください。

10. WIRING DIAGRAM

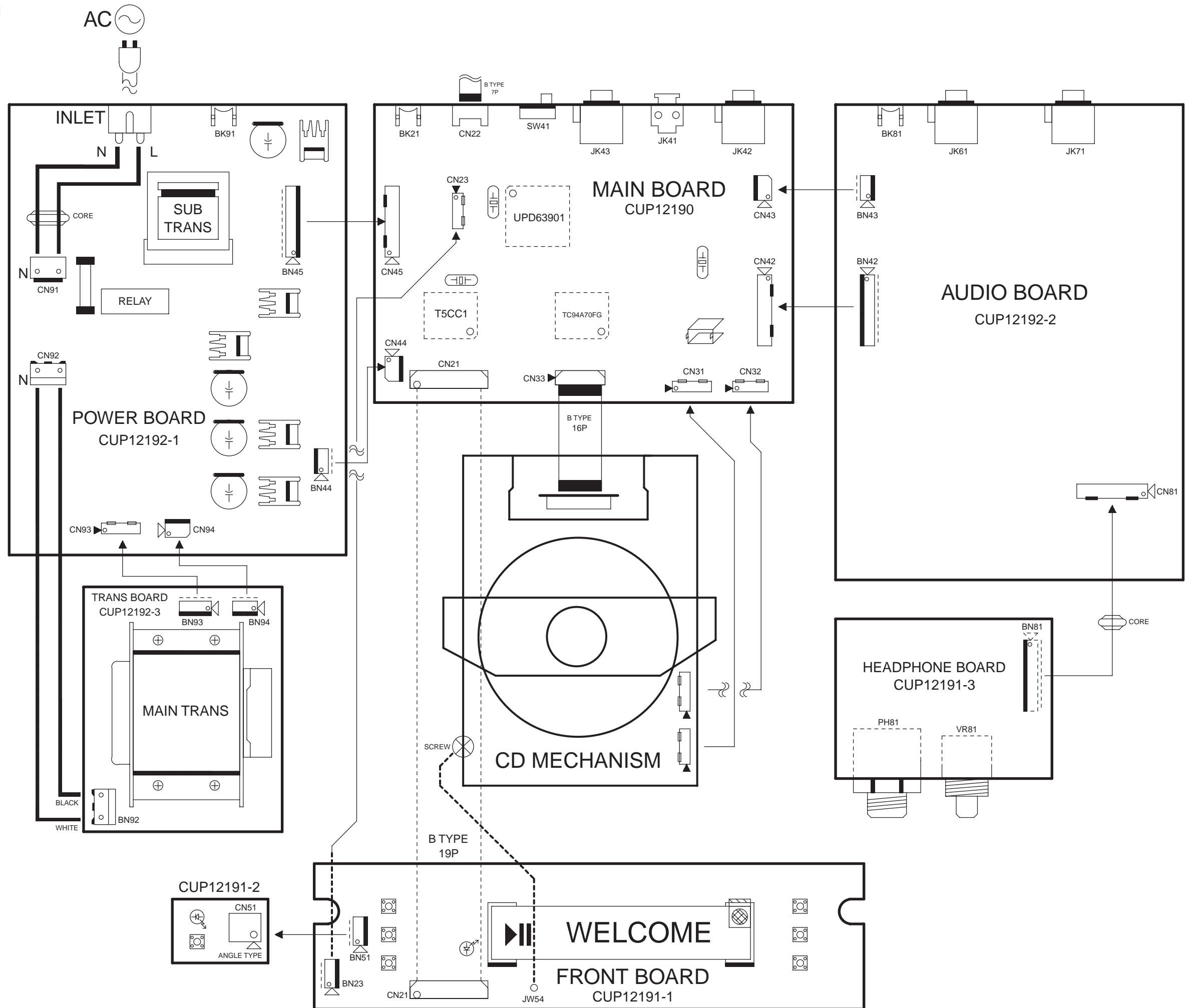

11. BLOCK DIAGRAM

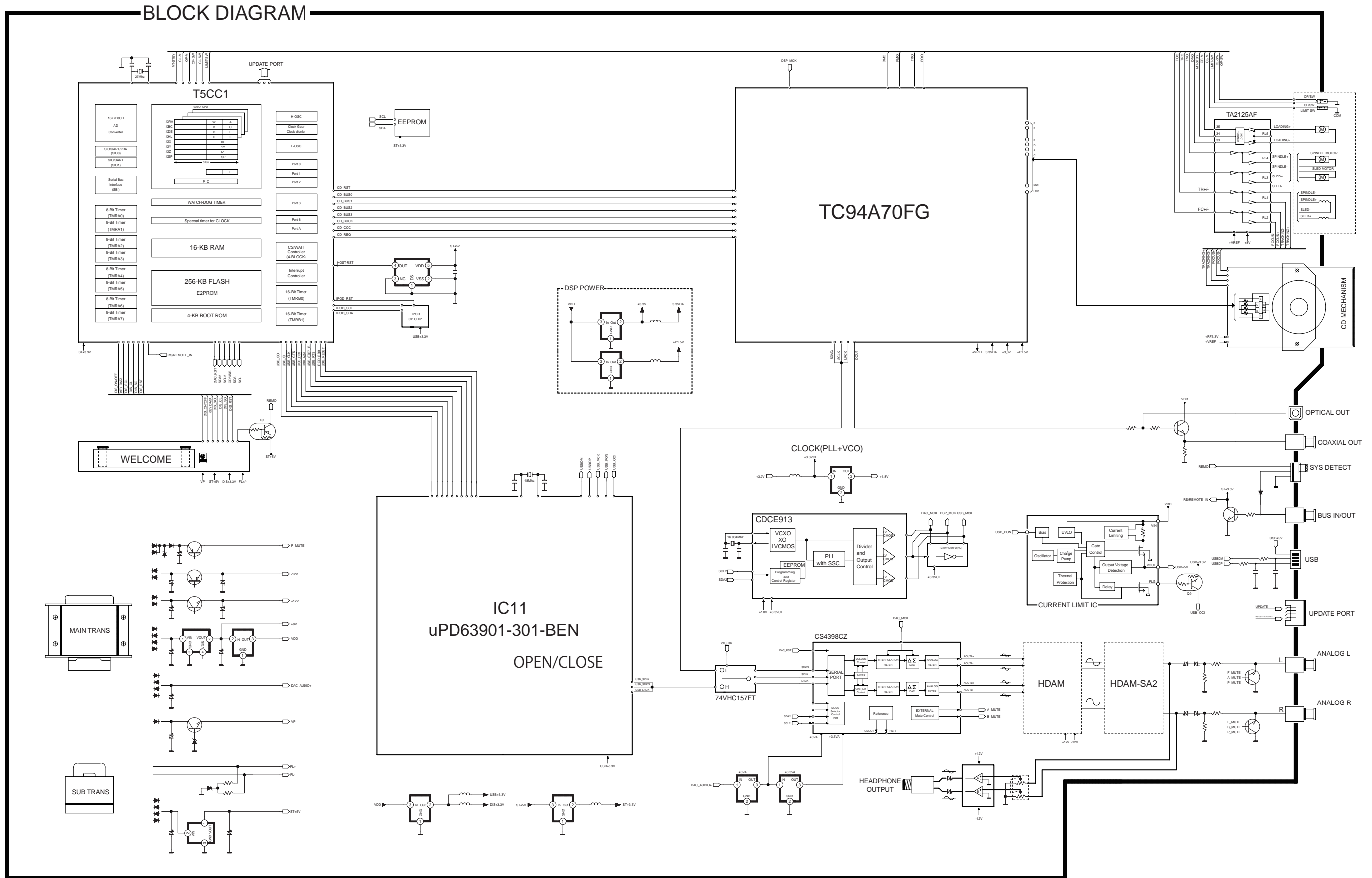

12. SCHEMATIC DIAGRAM

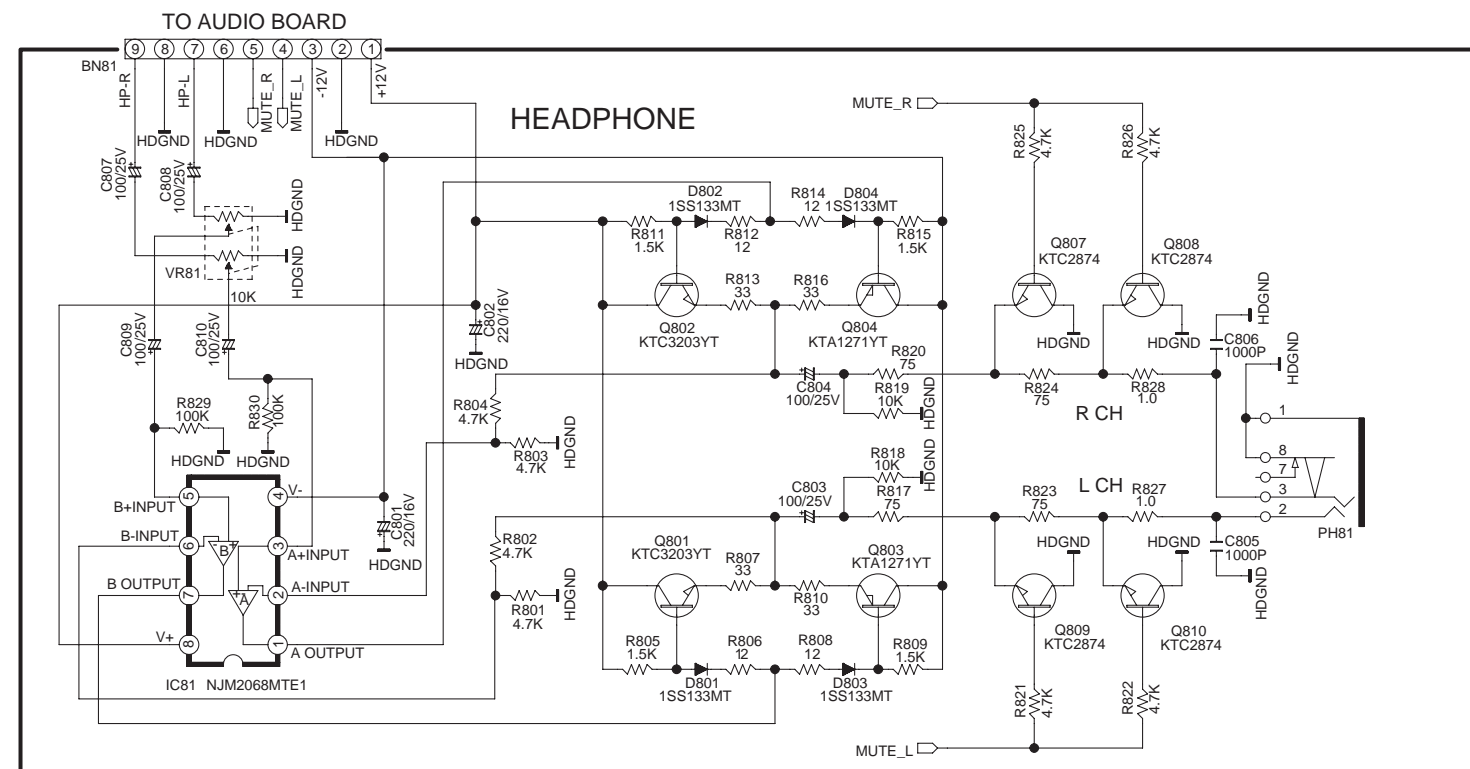
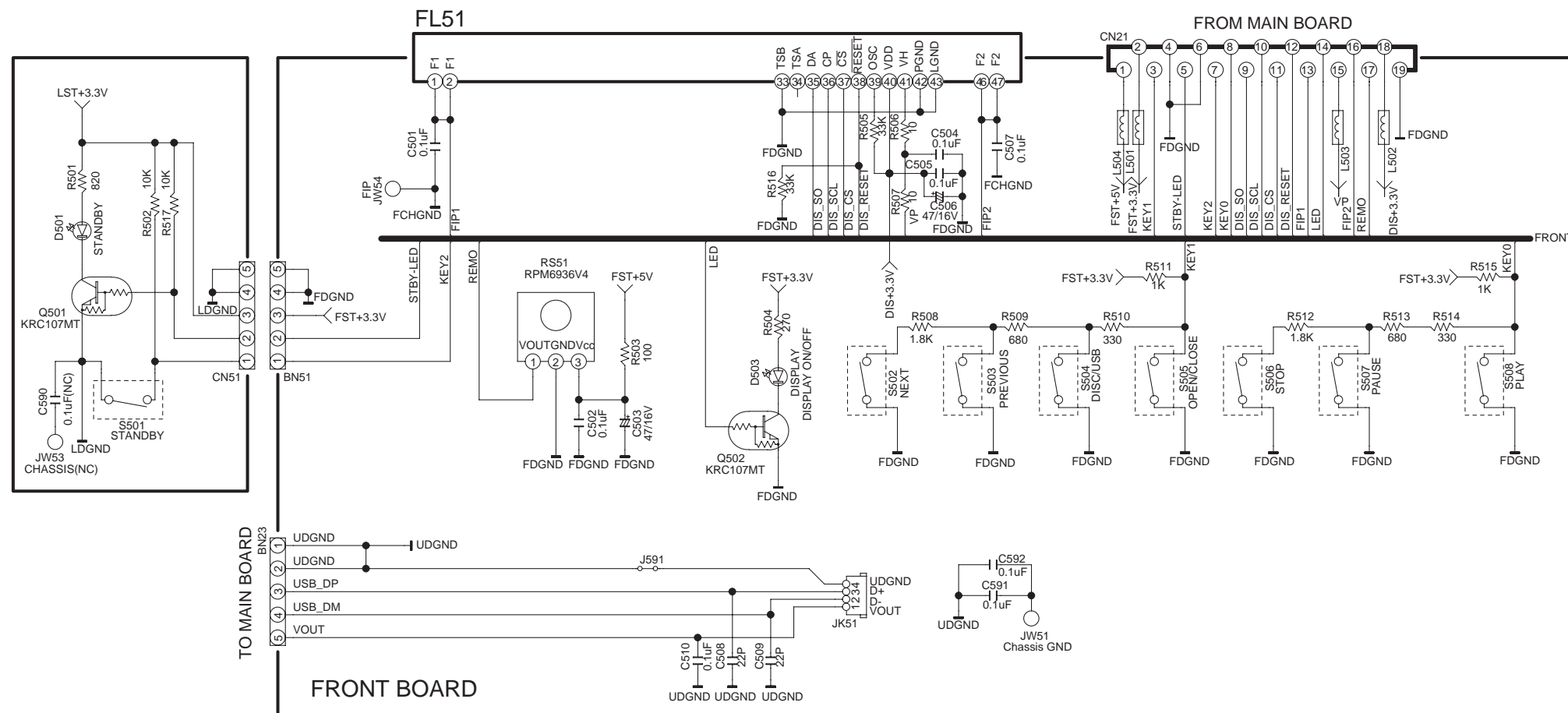

MAIN BOARD

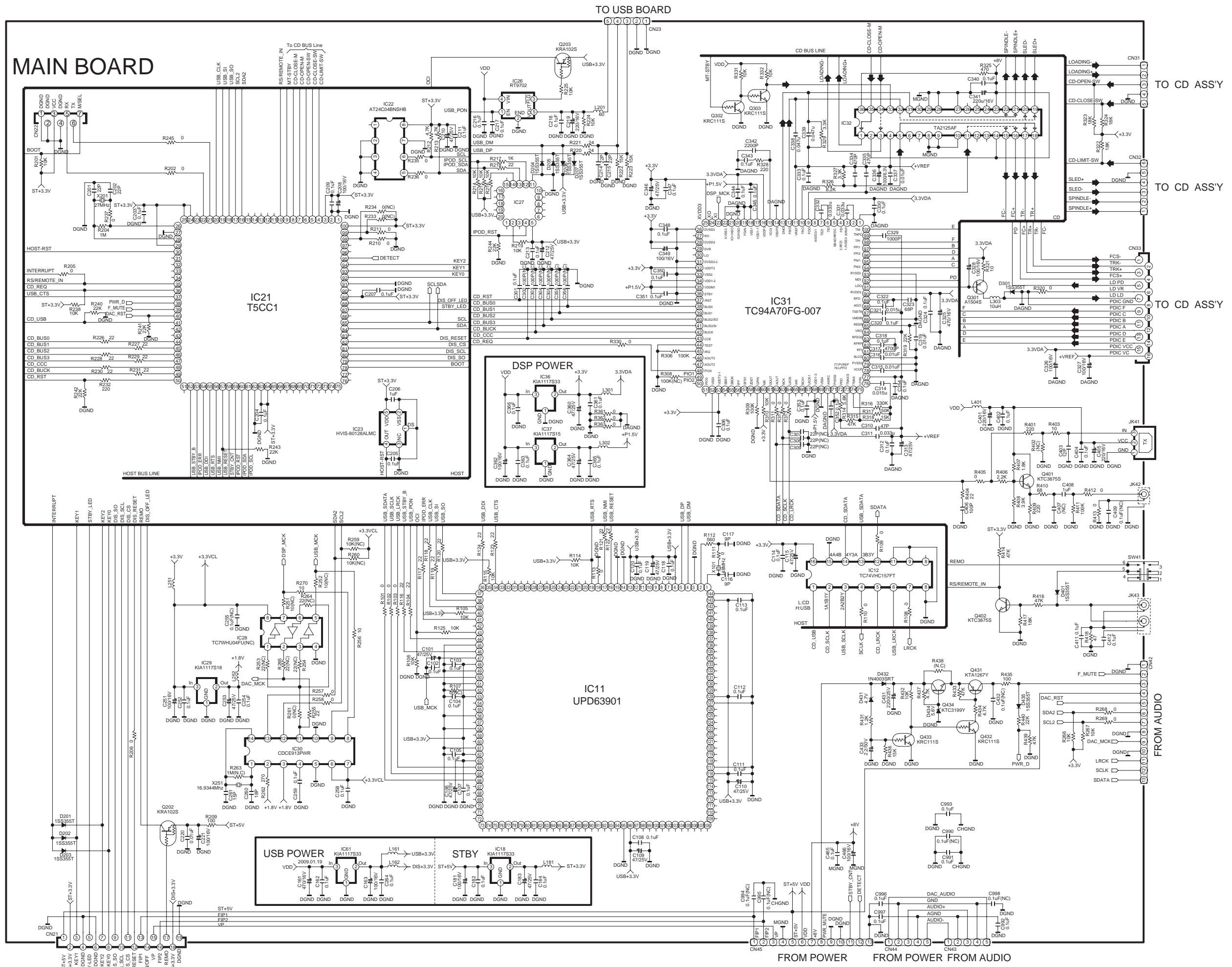

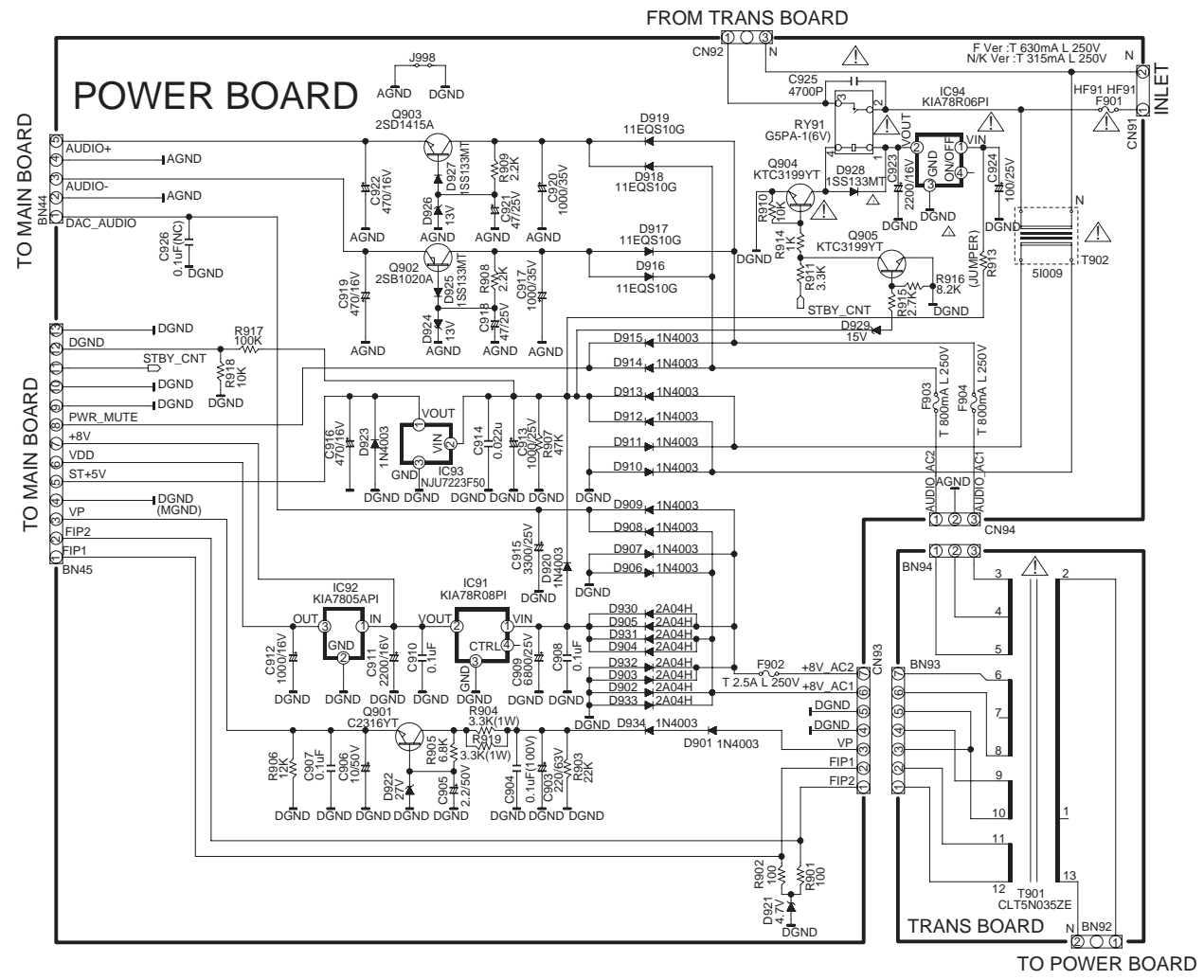
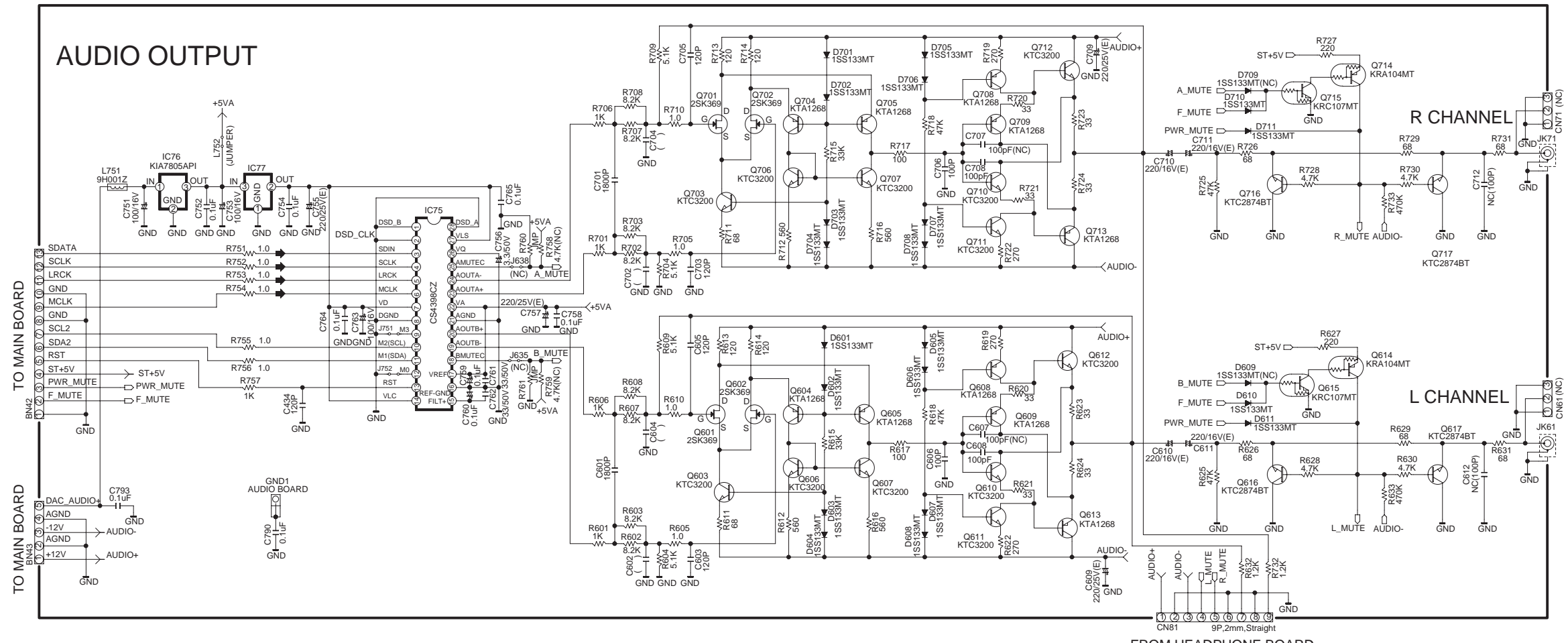

13. PARTS LOCATION

MAIN A PWB

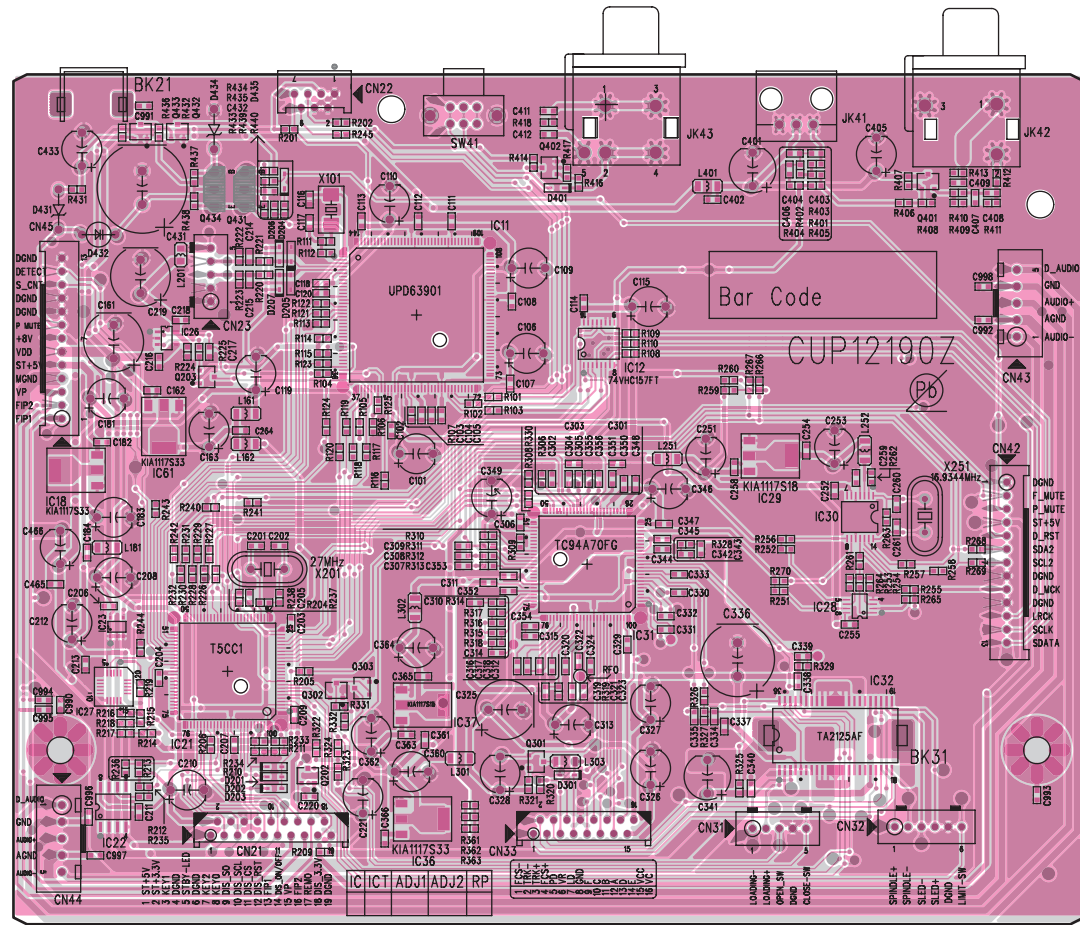

MAIN B PWB

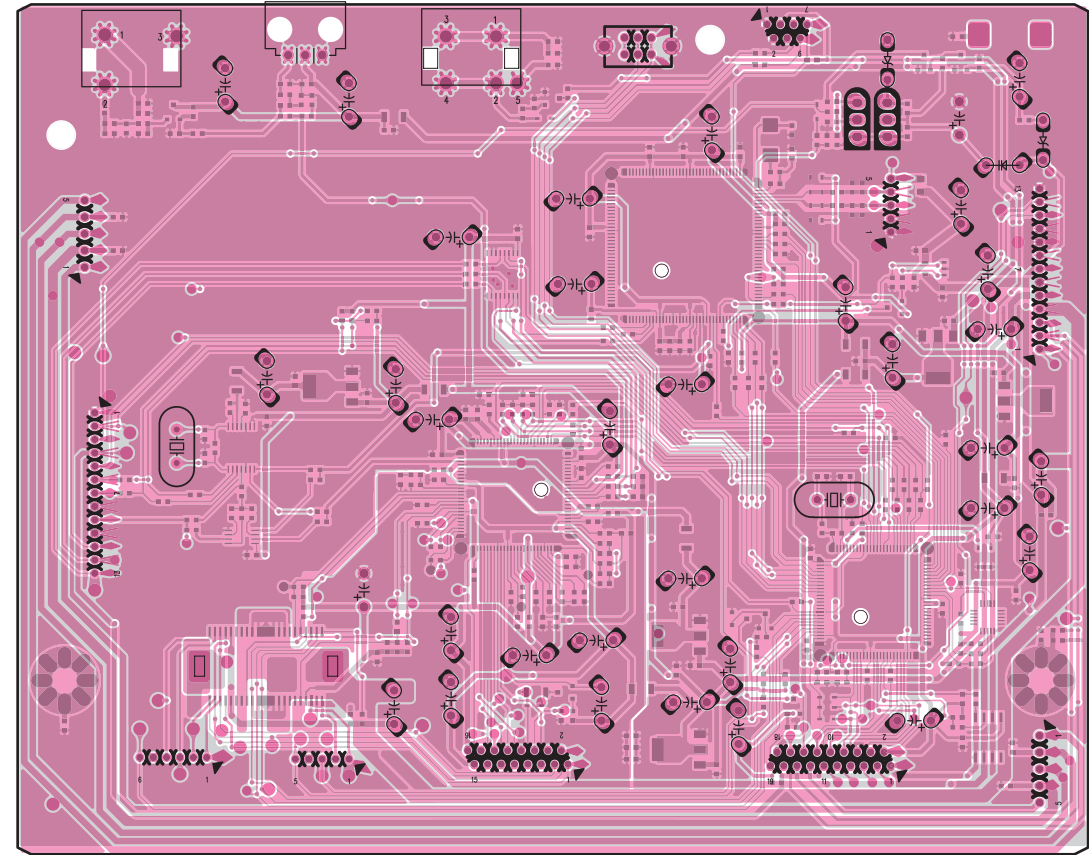

鉛フリー半田
 半田付けには、鉛フリー半田 (Sn-Ag-Cu) を使用してください。
Lead-free Solder
 When soldering, use the Lead-free Solder (Sn-Ag-Cu).

FRONT1 A PWB

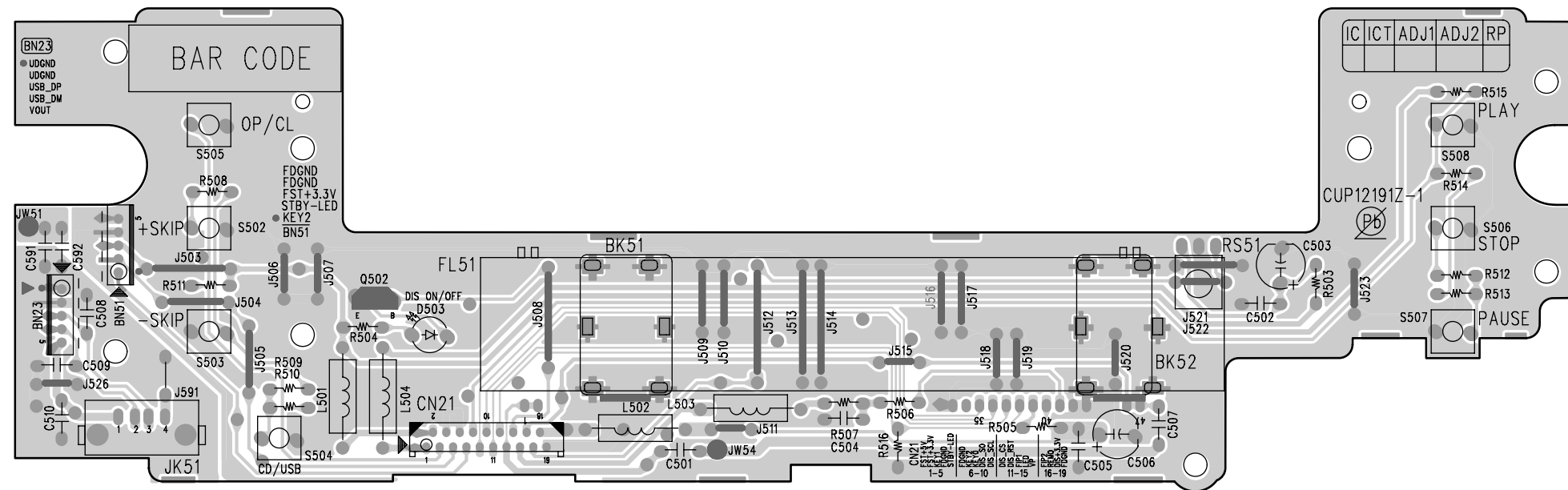

FRONT 1 B PWB

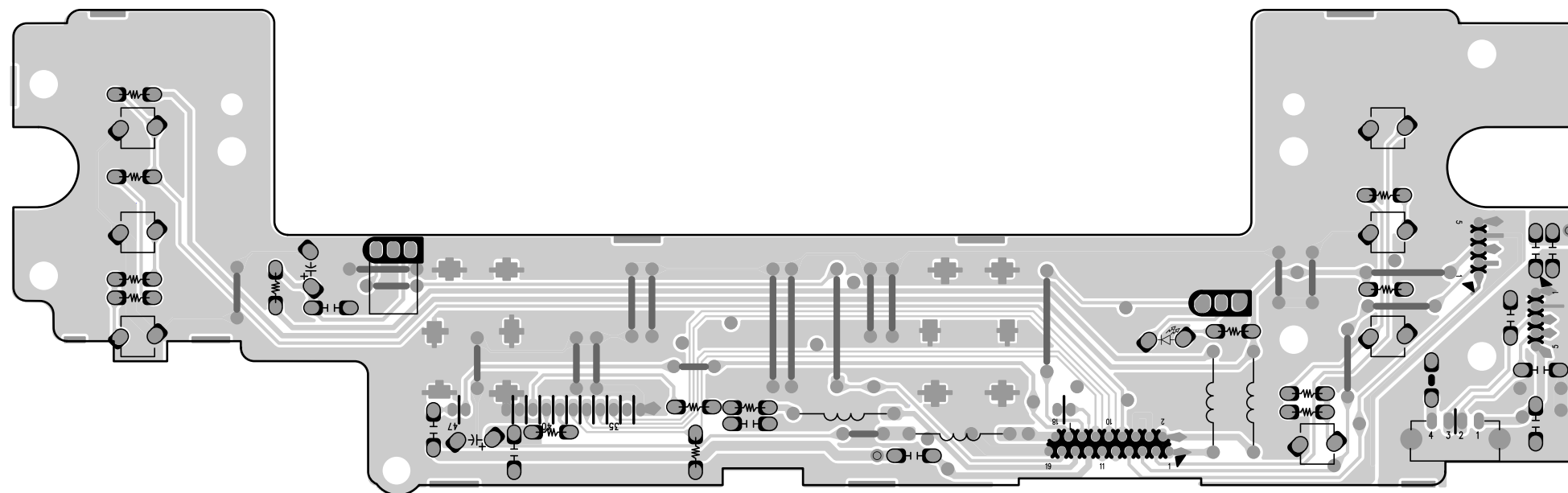

鉛フリー半田
半田付けには、鉛フリー半田 (Sn-Ag-Cu) を使用してください。
Lead-free Solder
When soldering, use the Lead-free Solder (Sn-Ag-Cu).

FRONT2 A PWB

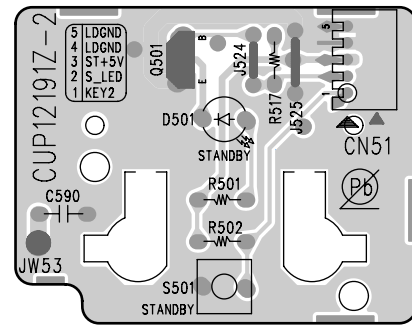

FRONT2 B PWB

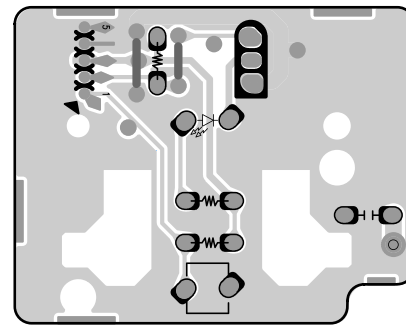

FRONT3 A PWB

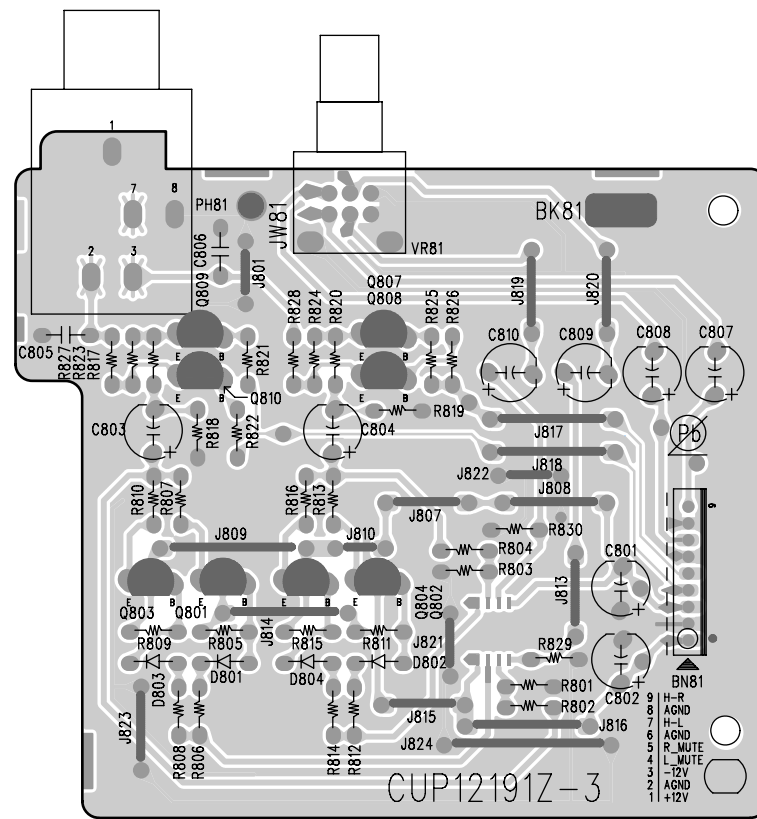

FRONT3 B PWB

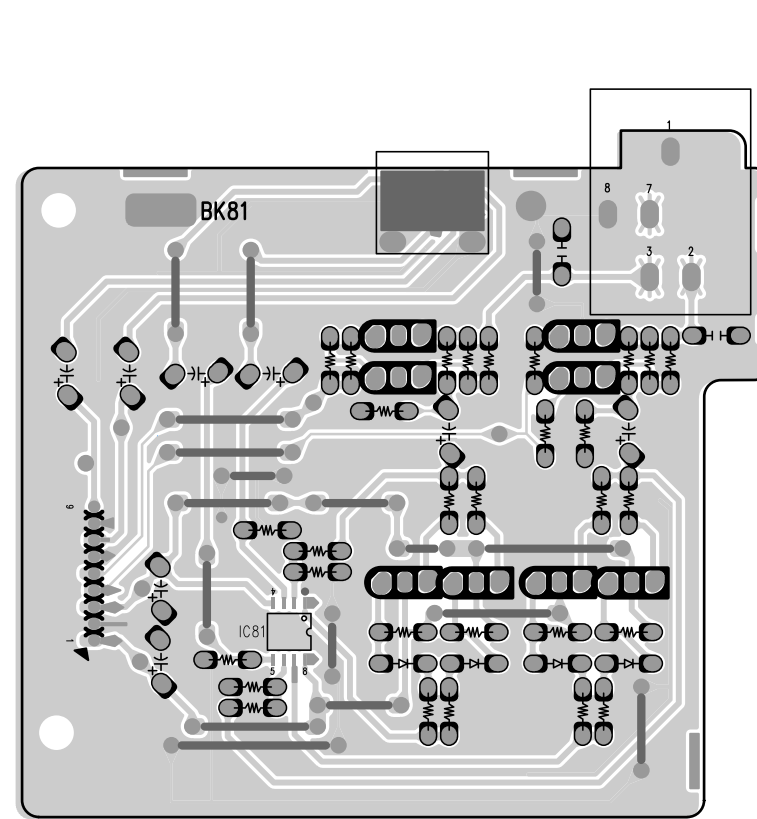

鉛フリー半田
半田付けには、鉛フリー半田 (Sn-Ag-Cu) を使用してください。

Lead-free Solder
When soldering, use the Lead-free Solder (Sn-Ag-Cu).

POWER1 A PWB

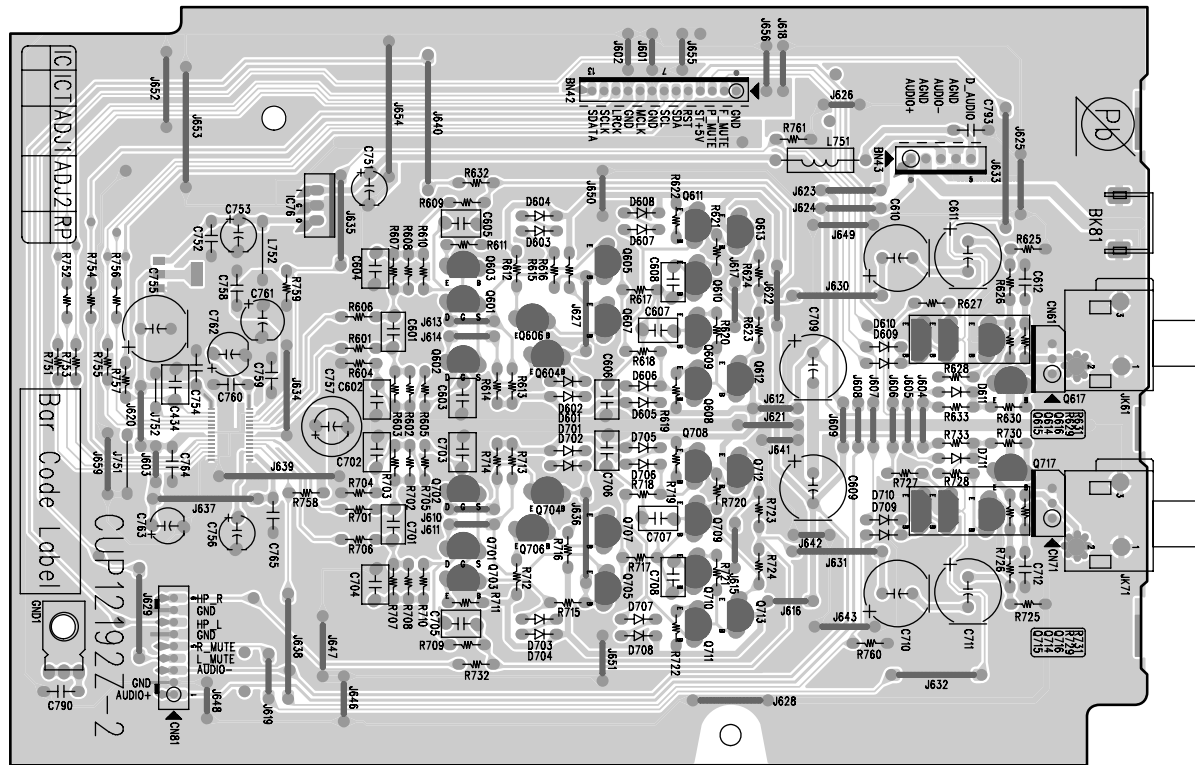

POWER1 B PWB

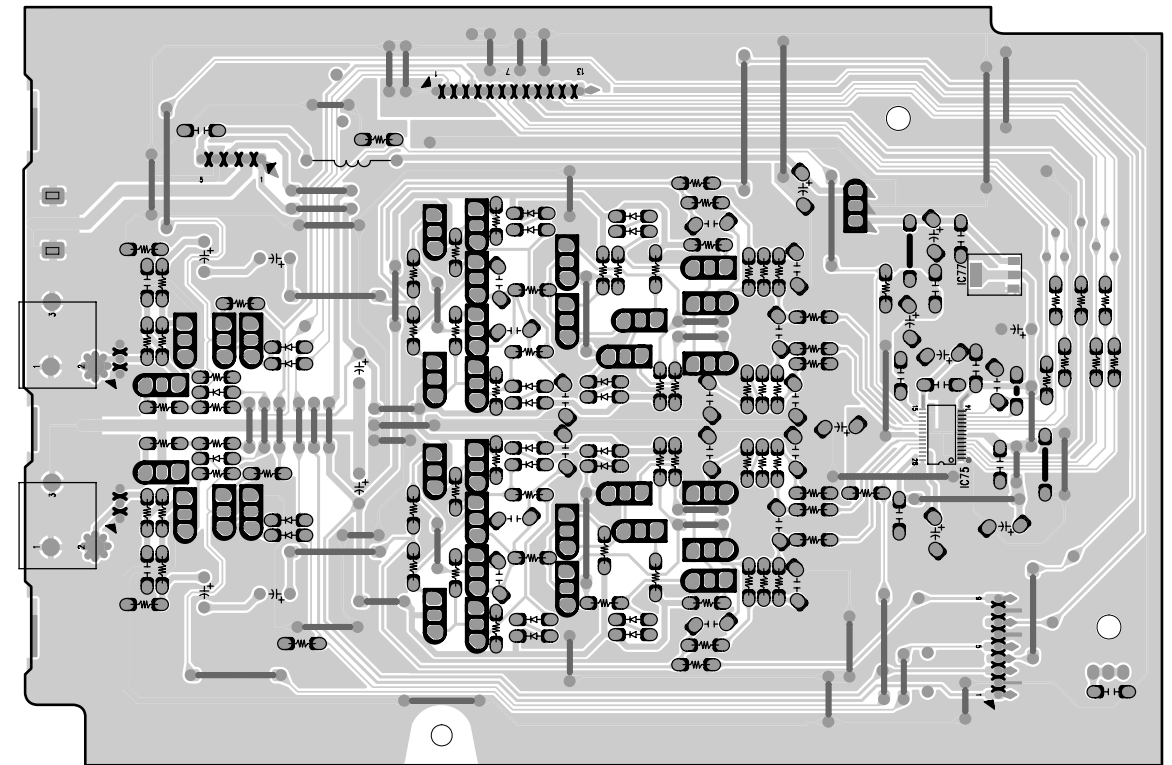

鉛フリー半田
半田付けには、鉛フリー半田 (Sn-Ag-Cu) を使用してください。
Lead-free Solder
When soldering, use the Lead-free Solder (Sn-Ag-Cu).

POWER2 A PWB

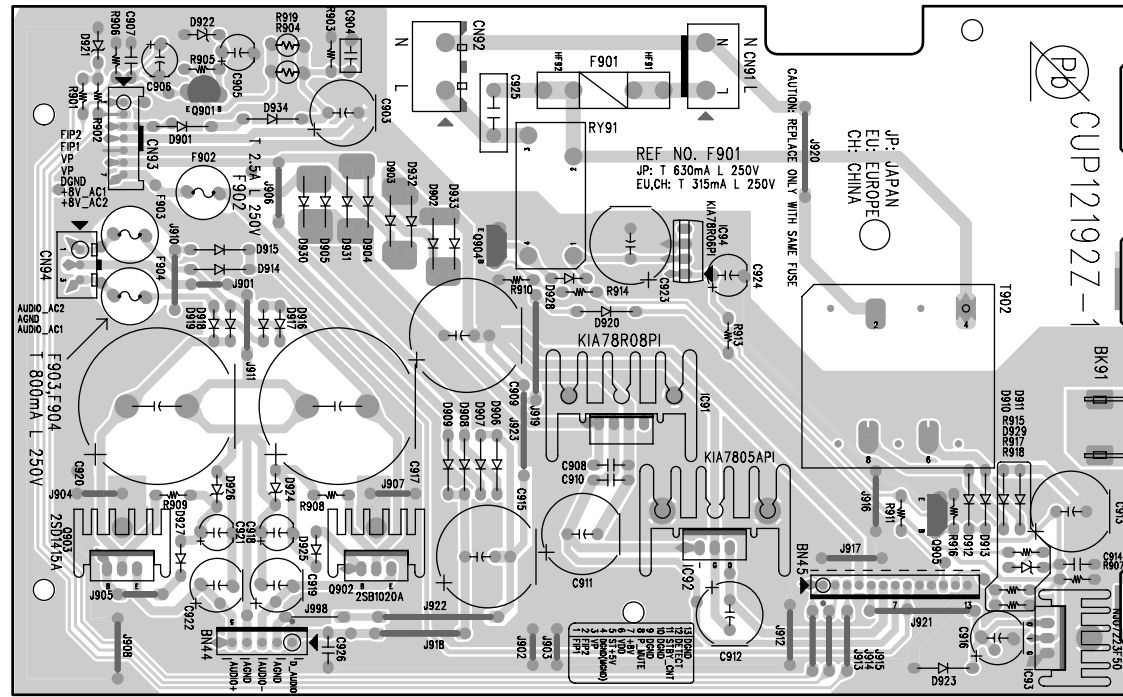

POWER2 B PWB

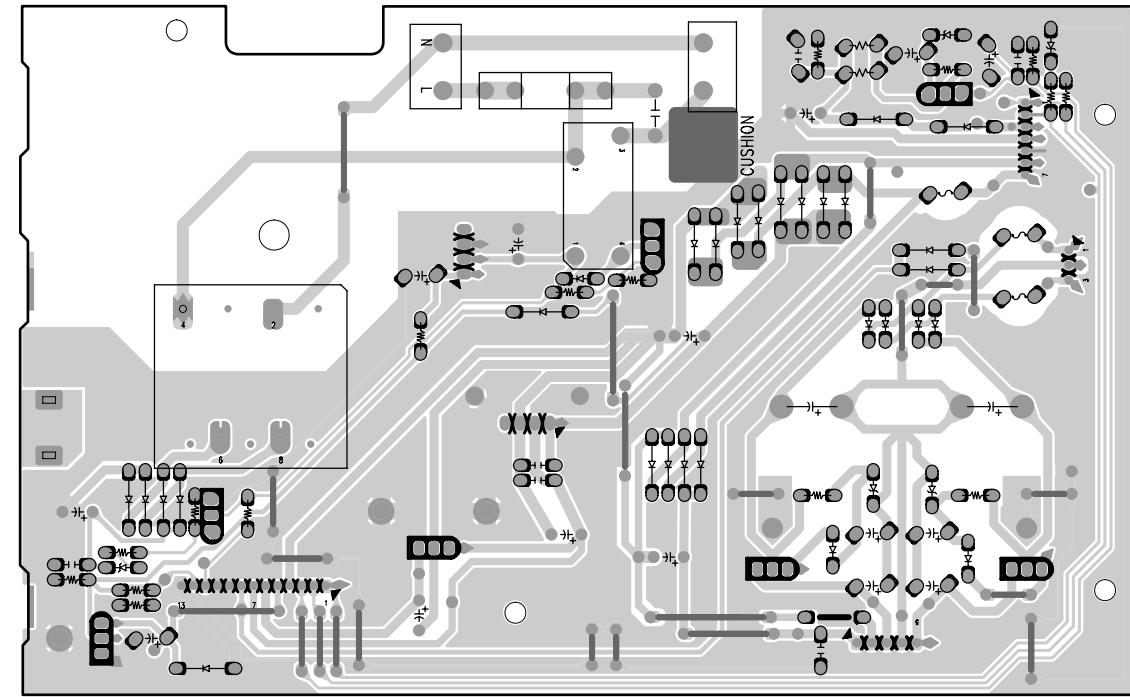

POWER3 A PWB

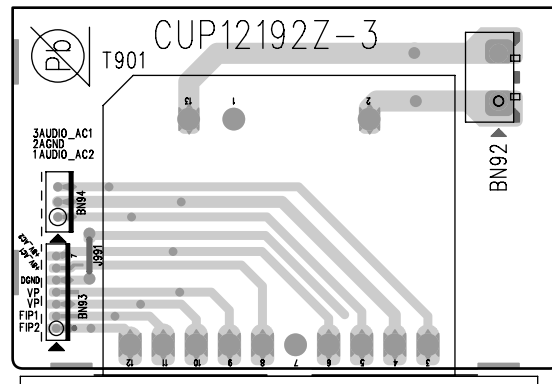

POWER3 B PWB

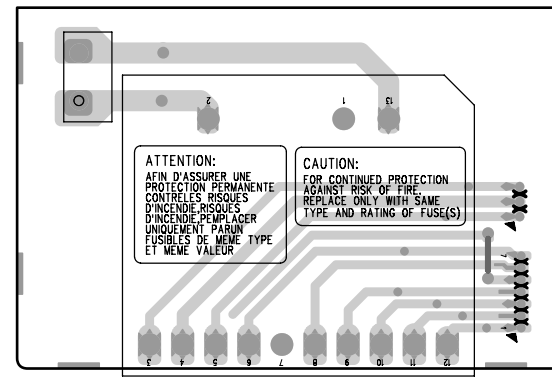

鉛フリー半田
半田付けには、鉛フリー半田 (Sn-Ag-Cu) を使用してください。

Lead-free Solder
When soldering, use the Lead-free Solder (Sn-Ag-Cu).

14. EXPLODED VIEW AND PARTS LIST

NO.	VERS.	COLOR	PARTS NO.	DESCRIPTION	Q'TY	A/S PART
S1			CTB3+6JR	SCREW	16	O.K
S2			CTB3+6FFB	SCREW	2	O.K
S3			CTBD3+8JFB	SCREW DOT	1	O.K
S4			CTB3+8JFB	SCREW	19	O.K
S5			CTW3+8JR	SCREW	6	O.K
S6	N1B		CTW3+8JFZR	SCREW	6	O.K
S6	N1SG, FN		CTW3+8JFC	SCREW	6	O.K
S7			CTB3+10JR	SCREW	12	O.K
S8			CTB3+10JFB	SCREW	5	O.K
S9			CTW3+12JR	SCREW	4	O.K
S10			CTW3+18JR	SCREW	3	O.K
S11			CHD2A023R	SCREW	4	O.K

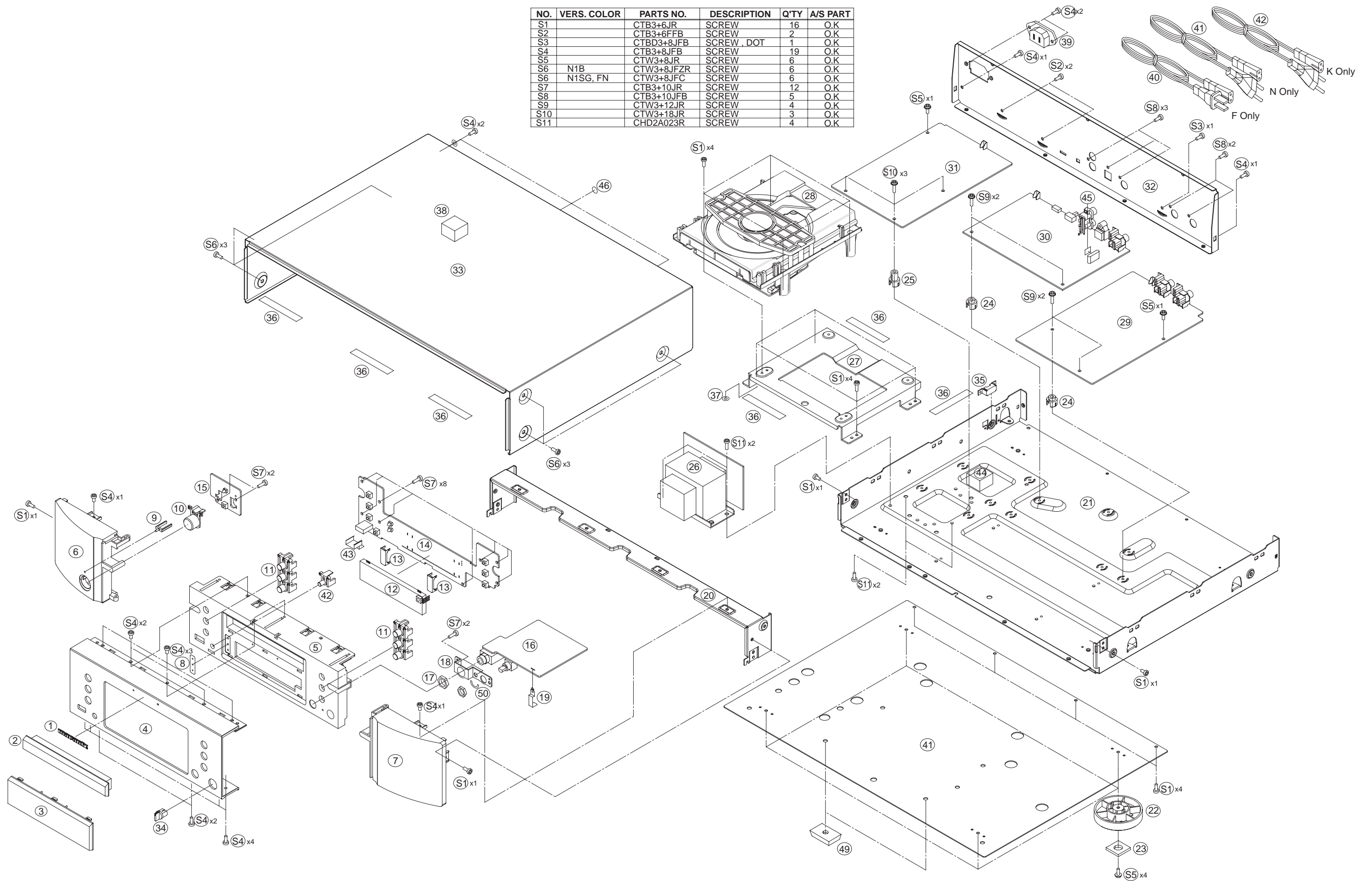

15. MICROPROCESSOR AND IC DATA

IC21 : T5CC1

Pin No	Pin Port	Name	Use	PortSetup		Note
				Act.	Init	
1	VREFL	GND	-	-	-	GMD for AD
2	AVSS	GND	-	-	-	GND
3	AVCC	ST+3.3V	AVCC	-	-	ST+3.3V
4	P70/TA0IN	CD_LIMIT_SW	I	-	-	Limit SW of CD Loader
5	P71/TA1OUT	CD_CLOSE_SW	I	-	-	Close SW of CD Loader
6	P72/TA3OUT	CD_OPEN_SW	I	-	-	Open SW of CD Loader
7	P73/TA4IN	CD_OPEN_M	O	H	L	Open Control for Motor Driver IC
8	P74/TA5OUT	CD_CLOSE_M	O	H	L	Close Control for Motor Driver IC
9	P75/TA7OUT	MT_STBY	O	L	L	Standby Control for Motor Driver IC
10	P80/TB0IN0/INT5	RS/REMOTE_IN				Remote Input
11	P81/TB0IN1/INT6					
12	P82/TB0OUT0					
13	P83/TB0OUT1					
14	P84/TB1IN0/INT7					
15	P85/TB1IN1/INT8					
16	P86/TB1OUT0	SDA2	O	-	-	I2C Data for DAC/PLL
17	P87/TB1OUT1	SCL2	O	-	-	I2C Clock for DAC/PLL
18	P90/TXD0	USB_SO	UART	-	-	Data Out for USB Control IC(uPD63901)
19	P91/RXD0	USB_SI	UART	-	-	Data In for USB Control IC(uPD63901)
20	P92/SCLK0/_CTS0	USB_CLK	UART	-	-	Clock for USB Control IC(uPD63901)
21	P93/TXD1	TXD	UART	-	-	Data Out for RS-232
22	P94/RXD1	RXD	UART	-	-	Data In from RS-232
23	P95/SCLK1/_CTS1					
24	AM0	AM0	I	-	-	Connect to DVCC
25	DVCC	ST+3.3V	DVCC	-	-	ST+3.3V
26	X2	XOUT	O	-	-	27MHz X'tal
27	DVSS	GND	-	-	-	GND
28	X1	XIN	I	-	-	27MHz X'tal
29	AM1	AM1	I	-	-	Connect to DVCC
30	_RESET	HOST_RESET	I	L	H	RESET
31	P96/XT1					
32	P97/XT2					
33	EMU0	EMU0	O	-	-	OPEN
34	EMU1	EMU1	O	-	-	OPEN
35	PA0/INT1	RS/REMOTE_IN	I	↓	-	Remote Input/Wake up Key Input
36	PA1/INT2	CD_REQ	I	↑	-	IREQ from CD DSP
37	PA2/INT3	USB_CTS	I	↓	-	CTS for USB Control IC(uPD63901)
38	PA3/INT4	PWR_D	I	↑	-	Power Down Detect
39	PA4	A_MUTE	O	H	H	Analog Mute
40	PA5	DAC_RST	O	L	H	DAC IC Reset
41	PA6	CD_USB	O	-	L	L:CD, H:USB
42	PA7					
43	ALE		-	-	-	Disable
44	P00/AD0	CD_BUS0	O	-	H	Data In/Out bus for CD DSP
45	P01/AD1	CD_BUS1	I/O	-	H	Data In/Out bus for CD DSP
46	P02/AD2	CD_BUS2	I/O	-	H	Data In/Out bus for CD DSP
47	P03/AD3	CD_BUS3	I/O	-	H	Data In/Out bus for CD DSP
48	P04/AD4	CD_CCC	I/O	L	H	Chip Enable for CD DSP
49	P05/AD5	CD_BUCK	O	L	H	Clock Out for CD DSP
50	P06/AD6	CD_RST	O	L	H	Reset to CD DSP
51	P07/AD7					
52	P10/AD8/A8	USB_STBY_B	O	L	H	Standby Control for USB Control IC(uPD63901)
53	P11/AD9/A9	IPOD_ERR	I	-	-	iPod Error from USB Control IC(uPD63901)

Pin No	Pin Port	Name	Use	PortSetup		Note
				Act.	Init	
54	P12/AD10/A10	USB_DDI	I	-	-	USB Error From USB Control IC(uPD63901)
55	P13/AD11/A11	USB_RTS	O	L	H	RTS for USB Control IC(uPD63901)
56	P14/AD12/A12	USB_NMI	I	-	-	Standby detect from USB Control IC(uPD63901)
57	P15/AD13/A13	USB_RESET	O	L	H	Reset for USB Control IC(uPD63901)
58	P16/AD14/A14	STBY_CNT	O	L	L	Standby Control L : Standby, H : Normal
59	P17/AD15/A15	IPOD_RST	O	L	H	Reset for iPod CP Chip
60	P20/A0/A16	IPOD_SDA	I/O	-	H	I2C Data for iPod CP
61	P21/A1/A17	IPOD_SCL	I/O	-	H	I2C Clock for iPod CP
62	DVSS	GND	-	-	-	GND
63	_NMI	_NMI	I	-	-	ST+3.3V
64	DVCC	ST+3.3V	DVCC	-	-	ST+3.3V
65	P22/A2/A18					
66	P23/A3/A19					
67	P24/A4/A20					
68	P25/A5/A21					
69	P26/A6/A22					
70	P27/A7/A23					
71	P30/_RD					
72	P31/_WR					
73	P32/_HWR					
74	P33/_WAIT					
75	P34/_BUSRQ					
76	P35/_BUSAK					
77	P36/R/_W					
78	P37/_BOOT	BOOT	I	-	-	Single Boot Mode (at P37=Low)
79	P40/_CS0	DIS_SO	O	-	H	Data Output for VFD
80	P41/_CS1	DIS_SCL	O	-	H	Clock Output for VFD
81	P42/_CS2	DIS_CS	O	L	H	CS for VFD
82	P43/_CS3	DIS_RESET	O	L	H	Reset for VFD
83	P60/SCK					
84	P61/SO/SDA	SDA	I/O			I2C Data for EEPROM
85	P62/SI/SCL	SCL	O			I2C Clock for EEPROM
86	P63/INT0					
87	P64/SCOUT	STBY_LED	O	L	L	Standby LED Control Normal : L, Standby : H -> Input Port
88	P65	DIS_OFF_LED	O	H	L	Display Off LED On
89	DVCC	ST+3.3V	DVCC	-	-	ST+3.3V
90	P66					
91	DVSS	GND	-	-	-	GND
92	P50/AN0	KEY0	AD	-	-	Front Key In 0
93	P51/AN1	KEY1	AD	-	-	Front Key In 1
94	P52/AN2	KEY2	AD	-	-	Front Key In 2
95	P53/AN3/_ADTRG	DETECT	AD	-	-	2 times AC voltage input detect
96	P54/AN4		AD			
97	P55/AN5		AD			
98	P56/AN6	MODEL_SEL0	AD	-	-	Model Select0
99	P57/AN7	MODEL_SEL1	AD	-	-	Model Select1
100	VREFH	ST+3.3V	-	-	-	ST+3.3V for AD

Programmable 1-PLL VCXO Clock Synthesizer With 1.8-V, 2.5-V, and 3.3-V Outputs

FEATURES

- Member of Programmable Clock Generator Family
 - CDCE913/CDCEL913: 1-PLL, 3 Outputs
 - CDCE925/CDCEL925: 2-PLL, 5 Outputs
 - CDCE937/CDCEL937: 3-PLL, 7 Outputs
 - CDCE949/CDCEL949: 4-PLL, 9 Outputs
- In-System Programmability and EEPROM
 - Serial Programmable Volatile Register
 - Nonvolatile EEPROM to Store Customer Setting
- Flexible Input Clocking Concept
 - External Crystal: 8 MHz to 32 MHz
 - On-Chip VCXO: Pull Range ± 150 ppm
 - Single-Ended LVCMOS up to 160 MHz
- Free Selectable Output Frequency up to 230 MHz
- Low-Noise PLL Core
 - PLL Loop Filter Components Integrated
 - Low Period Jitter (Typical 50 ps)
- Separate Output Supply Pins
 - CDCE913: 3.3 V and 2.5 V
 - CDCEL913: 1.8 V

- Flexible Clock Driver
 - Three User-Definable Control Inputs [S0/S1/S2], for example., SSC Selection, Frequency Switching, Output Enable, or Power Down
 - Generates Highly Accurate Clocks for Video, Audio, USB, IEEE1394, RFID, Bluetooth™, WLAN, Ethernet™, and GPS
 - Generates Common Clock Frequencies Used With TI-DaVinci™, OMAP™, DSPs
 - Programmable SSC Modulation
 - Enables 0-PPM Clock Generation
- 1.8-V Device Power Supply
- Wide Temperature Range -40° C to 85° C
- Packaged in TSSOP
- Development and Programming Kit for Easy PLL Design and Programming (TI Pro-Clock™)

APPLICATIONS

- D-TV, STB, IP-STB, DVD-Player, DVD-Recorder, Printer

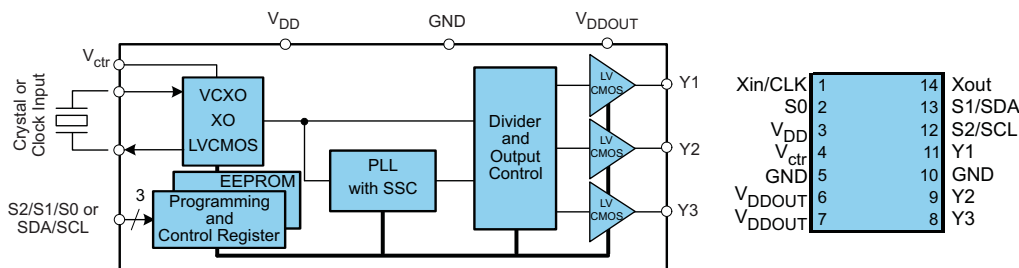

TERMINAL		I/O	DESCRIPTION
NAME	PIN TSSOP14		
Y1–Y3	11, 9, 8	O	LVCMOS outputs
Xin/CLK	1	I	Crystal oscillator input or LVCMOS clock Input (selectable via SDA/SCL bus)
Xout	14	O	Crystal oscillator output (leave open or pullup when not used)
V _{ctr}	4	I	VCXO control voltage (leave open or pullup when not used)
V _{DD}	3	Power	1.8-V power supply for the device
V _{DDOUT}	6, 7	Power	CDCEL913: 1.8-V supply for all outputs
			CDCE913: 3.3-V or 2.5-V supply for all outputs
GND	5, 10	Ground	Ground
S0	2	I	User-programmable control input S0; LVCMOS inputs; internal pullup 500k
SDA/S1	13	I/O or I	SDA: bidirectional serial data input/output (default configuration), LVCMOS internal pullup; or S1: user-programmable control input; LVCMOS inputs; internal pullup 500k
SCL/S2	12	I	SCL: serial clock input LVCMOS (default configuration), internal pullup 500k or S2: user-programmable control input; LVCMOS inputs; internal pullup 500k

IC31 : TC94A70FG

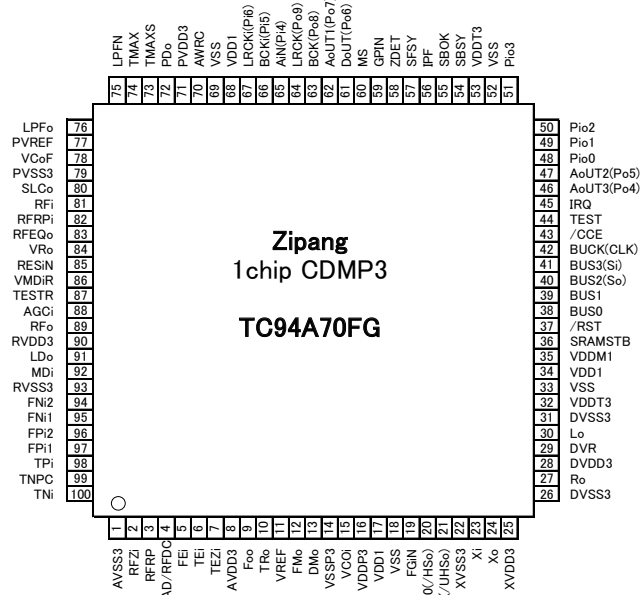
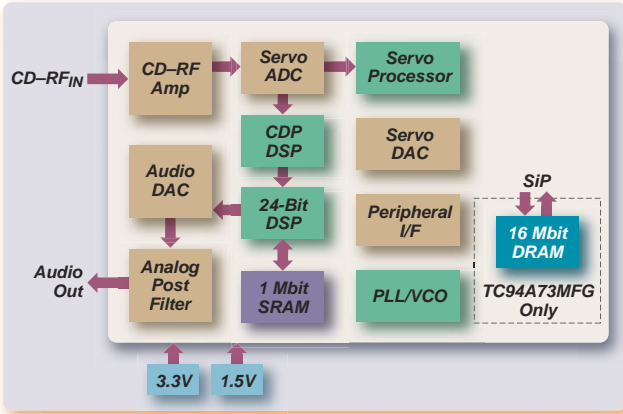

Zipang
1chip CDMFP3
TC94A70FG

Pin No.	Symbol	I/O	Description	Default	Remarks
1	AVSS3	—	Grounding pin for 3.3V CD analog circuits.	—	
2	RFZi	I 3A/I/F	Input pin for RF ripple zero-cross signal.	I	Connect to RFRP by 0.033uF
3	RFRP	O 3A/I/F	RF ripple signal output pin.	O	Monitor pin for the signal.
4	SBAD/RFDC	O 3A/I/F	Sub beam addition signal or RFDC (Hologram PUH RF peak detection signal) signal output pin	O	
5	FEi	O 3A/I/F	Focus error signal input pin.	O	
6	TEi	O 3A/I/F	Tracking error signal input pin.	O	
7	TEZi	I 3A/I/F	Tracking error signal zero-cross input pin.	I	Connect to TEI by 0.033uF
8	AVDD3	—	Power supply pin for 3.3 V CD analog circuits.	—	
9	Foo	O 3A/I/F	Focus servo equalizer output pin.	O	Built-in series resistor 3.3k Ω
10	TRo	O 3A/I/F	Tracking servo equalizer output pin.	O	
11	VREF	—	Reference voltage pin for analog circuits(1.65V)	—	Connect to VRO and PVREF. Connect 0.1uF
12	FMo	O 3A/I/F	Feed servo equalizer output pin.	O	Built-in series resistor 3.3k Ω 3-state output (AVDD3,AVSS3,VREF)
13	DMo	O 3A/I/F	Disc servo equalizer output pin	O	
14	VSSP3	—	Grounding pin for 3.3V DSP VCO circuits.	—	
15	VCOi	I 3A/I/F	DSP VCO control voltage input pin.	I	
16	VDDP3	—	Power supply pin for 3.3V DSP VCO circuit.	—	
17	VDD1	—	Power supply pin for 1.5V digital circuit	—	
18	VSS	—	Grounding pin for 1.5V digital circuit.	—	
19	FGIN	I 3I/F	FG signal input pin for CAV. CLV: 'L', CAV: FG input	I	Analog input
20	io0/(HSo)	I/O 3I/F	General Input/output port -0 (CD) (Playback speed mode flag output pin.)	I	Schmitt input CMOS PORT
21	io1/(UHSo)	I/O 3I/F	General Input/output port -1 (CD) (Playback speed mode flag output pin.)	I	Schmitt input CMOS PORT
22	XVSS3	—	Grounding pin for 3.3V system clock oscillator circuit.	—	
23	Xi	I 3A/I/F	Input pin for system clock oscillator Circuit (External Rfb=1MΩ)	I	X'tal
24	Xo	O 3A/I/F	Output pin for system clock oscillator circuit	O	X'tal
25	XVDD3	—	Power supply pin for 3.3 V system clock oscillator circuit	—	

Pin No.	Symbol	I/O	Description	Default	Remarks
26	DVSS3	—	Grounding pin for 3.3V DAC circuit	—	
27	Ro	O 3A/I/F	R channel audio output pin of Audio DAC.	O	No capacitor required to DVR pin when built-in audio DAC is not in use, however , connect 3.3V to DVDD3 and GND to DVSS3.
28	DVDD3	—	Power supply pin for 3.3V Audio DAC circuit.	—	
29	DVR	—	Reference voltage pin for Audio DAC.	—	
30	Lo	O 3A/I/F	L channel audio output pin of Audio DAC	O	
31	DVSS3	—	Grounding pin for 3.3V Audio DAC circuit	—	
32	VDDT3	—	Power supply pin for 3.3 V digital I/O circuit.	—	For CD and DSP I/O
33	VSS	—	Grounding pin for 3.3V digital circuit	—	-
34	VDD1	—	Power supply pin for 1.5V digital circuit.	—	-
35	VDDM1	—	Power supply pin for 1.5V 1Mbit SRAM.	—	
36	SRAMSTB	I 3I/F	1Mbit SRAM stand-by pin	I	Schmitt input
37	/RST	I 3I/F	Reset signal input pin.	I	Schmitt input
38	BUS0	IO 3I/F	Data input/output pin -0 for microcontroller interface	I	Schmitt input CMOS PORT
39	BUS1	IO 3I/F	Data input/output pin -1 for microcontroller interface	I	Schmitt input CMOS PORT
40	BUS2(So)	IO 3I/F	Data input/output pin -2 for microcontroller interface (Serial output)	I	Schmitt input CMOS PORT
41	BUS3(Si)	IO 3I/F	Data input/output pin -3 for microcontroller interface (Serial input)	I	Schmitt input CMOS PORT
42	BUCK(CLK)	I 3I/F	Clock input pin for the microcontroller interface. (Clock input for Serial communication interface)	I	Schmitt input
43	/CCE	I 3I/F	Chip enable signal input pin for microcontroller interface.	I	Schmitt input
44	TEST	I 3I/F	Setting pin for LSI test mode. (Connect to GND in normal operation)	I	Schmitt input
45	IRQ	I 3I/F	DSP interruption pin.(Pull down by 100kΩ when not in use)	I	Schmitt input
46	AoUT3(Po4)	O 3I/F	Audio data output pin -3 (DSP general output port -4)	O	CMOS PORT
47	AoUT2(Po5)	O 3I/F	Audio data output pin -2 (DSP general output port -5)	O	CMOS PORT
48	Pio0	I/O 3I/F	DSP general input/output port -0	I	Schmitt input CMOS PORT
49	Pio1	I/O 3I/F	DSP general input/output port -1	I	Schmitt input CMOS PORT
50	Pio2	I/O 3I/F	DSP general input/output port -2	I	Schmitt input CMOS PORT
51	Pio3	I/O 3I/F	DSP general input/output port -3	I	Schmitt input CMOS PORT
52	VSS	—	Grounding pin for 3.3V digital circuit	—	-
53	VDDT3	—	Power supply pin for 3.3 V digital I/O circuit.	—	For CD and DSP I/O
54	SBSY	O 3I/F	Sub code block sync output pin	O	CMOS PORT
55	SBOK	O 3I/F	CRCC check result output pin for sub code Q data.	O	CMOS PORT

IC31 : TC94A70FG

Pin No.	Symbol	I/O	Description	Default	Remarks
56	IPF	O 3I/F	Correction flag output	O	CMOS PORT
57	SFSY	O 3I/F	Servo internal register read clock output pin	O	CMOS PORT
58	ZDET	O 3I/F	Internal Audio DAC Zero data detection flag output	O	CMOS PORT
59	GPIN	I 3I/F	CD General Input port(Pull down by 100K Ω when not in use)	I	Schmitt input
60	MS	I 3I/F	Microprocessor I/F mode selection pin. "L": Parallel I/F, "H": Serial I/F	I	
61	DoUT(Po6)	O 3I/F	Digital Audio output (SPDIF) pin (DSP general output port -6)	O	CMOS PORT
62	AoUT1(Po7)	O 3I/F	Audio data output pin -1(DSP general output port -7)	O	CMOS PORT
63	BCKo(Po8)	O 3I/F	Bit clock output pin for AoUT (DSP general output port -8)	O	CMOS PORT
64	LRCKo(Po9)	O 3I/F	L/R channel clock output pin (DSP general output port -9)	O	CMOS PORT
65	AIN(Pi4)	I 3I/F	Audio data input for Audio DAC (DSP general input port -4)	I	Schmitt input
66	BCKi(Pi5)	I 3I/F	Bit clock input pin for AIN (DSP general input port -5)	I	Schmitt input
67	LRCKi(Pi6)	I 3I/F	L/R channel clock for AIN (DSP general input port -6)	I	Schmitt input
68	VDD1	—	Power supply pin for 1.5V digital circuit.	—	
69	VSS	—	Grounding pin for 1.5V digital circuit.	—	
70	AWRC	O 3A/I/F	VCO control pin for active wide-range PLL	O	Applicable in CLV/CAV mode. Connect 0.033 uF.
71	PVDD3	—	Power supply pin for 3.3V CD PLL circuit.	—	
72	PD _o	O 3A/I/F	EFM and PLCK Phase difference signal output pin.	O	4-state output (PVDD3, Hiz,PVSS3,PVREF)
73	TMAXS	O 3A/I/F	TMAX detection result output pin	O	3-state output (PVDD3,PVSS3,Hiz)
74	TMAX	O 3A/I/F	TMAX detection result output pin	O	3-state output(PVDD3,PVSS3,Hiz)
75	LPFN	I 3A/I/F	PLL circuit LPF amplifier inversion input pin	I	Connect resistor of LPF, refer to application circuit diagram.
76	LPFo	O 3A/I/F	PLL circuit LPF amplifier Output pin	O	Connect capacitor of LPF, refer to application circuit diagram.
77	PVREF	—	PLL circuit 1.65 V reference voltage pin.	—	Connected to VREF and VRO inside of IC. Connect 0.1uF.
78	VCoF	O 3A/I/F	VCO filter pin	O	Connect 0.01uF.
79	PVSS3	—	Grounding pin for 3.3V CD PLL circuit.	—	
80	SLCo	O 3A/I/F	EFM slice level output pin. Output impedance =2.5k Ω both of analog/digital slice mode.	O	Connect capacitor according with servo frequency band.
81	RFi	I 3A/I/F	RF signal input pin Zin is selectable by command.	I	Zin : 20k Ω , 10k Ω , 5k Ω
82	RFRPi	I 3A/I/F	RF ripple signal input pin	I	

Pin No.	Symbol	I/O	Description	Default	Remarks
83	RFEQ _o	O 3A/I/F	RF equalizer circuit output pin.	O	Connect to RFRPi by 0.1uF, to RFi by 4700pF.
84	VR _o	O 3A/I/F	1.65 V reference voltage output pin.	O	Connected to VREF and PVREF inside of IC. Connect 0.1uF+100uF.
85	RESIN	O 3A/I/F	Pin for connecting a resistor for reference current generation.	O	Connect 22k Ω /0.01uF.
86	VMDIR	—	Reference voltage output pin for LD APC.	—	Connect 0.1uF
87	TESTR	O 3A/I/F	LPF connection pin for RFEQ _o offset correction circuit.	O	Connect more than 0.015uF.
88	AGCi	I 3A/I/F	RF signal AGC amplifier input pin	I	
89	RF _o	O 3A/I/F	RF signal generation amplifier output pin	O	
90	RVDD3	—	Power supply for 3.3V RF amplifier core circuit.	—	
91	LDo	O 3A/I/F	Laser diode amplifier output pin.		
92	MDi	I 3A/I/F	Monitor photodiode amplifier input pin.	I	Reference Voltage=178mVtyp.
93	RVSS3	—	Grounding pin for RF amplifier core circuit	—	
94	FNi2	I 3A/I/F	Main beam signal input pin. To be connected to PIN diode C.	I	
95	FNi1	I 3A/I/F	Main beam signal input pin. To be connected to PIN diode A.	I	
96	FPI2	I 3A/I/F	Main beam signal input pin. To be connected to PIN diode D.	I	
97	FPI1	I 3A/I/F	Main beam signal input pin. To be connected to PIN diode B.	I	
98	TPi	I 3A/I/F	Sub beam signal input pin. To be connected to PIN diode F.	I	
99	TNPC	O 3A/I/F	TNI/TPi input common capacitor connection pin.	O	Connect to VRO by capacitor.
100	TNi	I 3A/I/F	Sub beam signal input pin. To be connected to PIN diode E.	I	

* 3A I/F : : 3 V analog circuit input/output pin.
1.5 I/F : 1.5V digital input/output pin.
3 I/F : 3 V digital input/output pin.

Note: The servo output pins (FOO, TRO, FMO, and DMO) become undefined or GND level under the following conditions:

- /RST pin = Low
- Crystal oscillation stopped according to the instructions by the Stop crystal oscillation command
- Power supply for CD is OFF.
- SRAMSTB pin = High

To prevent the undefined pin states from affecting the servo circuitry or any other mechanical blocks in the system, appropriate measures should be taken, such as using a driver IC supporting a standby feature to place the system in standby mode while either of the above conditions is satisfied.

IC32 : TA2125AF

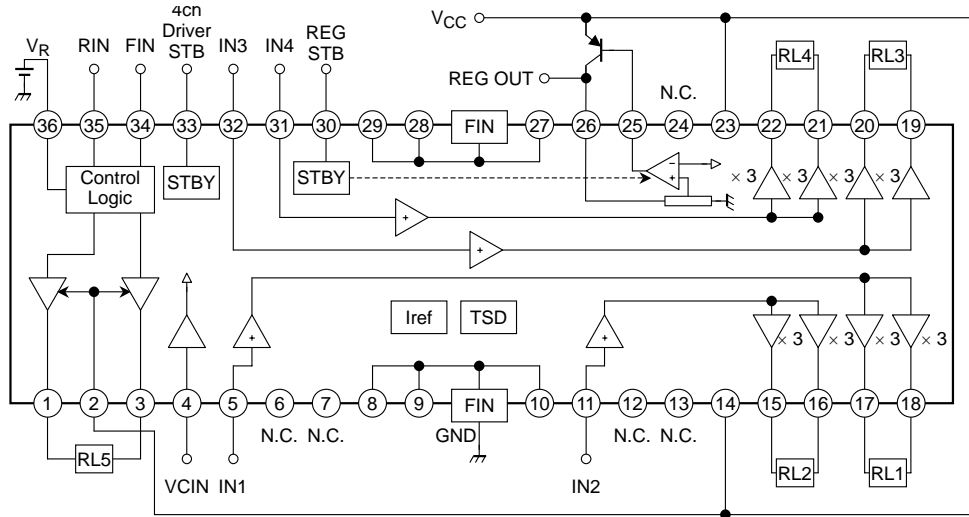

No.	Symbol	Function	
1	OUT5A	Output terminal	H-bridge
2	V _M	Supply voltage terminal for Logic	H-bridge
3	OUT5B	Output terminal	H-bridge
4	V _{CIN}	Input reference voltage	4ch BTL
5	IN1	Input for ch1	4ch BTL
6	N.C.	Open	—
7	N.C.	Open	—
8	N.C.	8, 9, 10, 27, 28, 29 are connected to PW GND (FIN)	—
9	N.C.	8, 9, 10, 27, 28, 29 are connected to PW GND (FIN)	—
10	N.C.	8, 9, 10, 27, 28, 29 are connected to PW GND (FIN)	—
11	IN2	Input for ch2	4ch BTL
12	N.C.	Open	—
13	N.C.	Open	—
14	V _{CC1}	Supply voltage terminal for ch1/ch2	4ch BTL
15	OUT2M	Inverted output for ch2	4ch BTL
16	OUT2P	Non-inverted output for ch2	4ch BTL
17	OUT1M	Inverted output for ch1	4ch BTL
18	OUT1P	Non-inverted output for ch1	4ch BTL
19	OUT3P	Non-inverted output for ch3	4ch BTL
20	OUT3M	Inverted output for ch3	4ch BTL
21	OUT4P	Non-inverted output for ch4	4ch BTL
22	OUT4M	Inverted output for ch4	4ch BTL
23	V _{CC2}	Supply voltage terminal for ch3/ch4	4ch BTL
24	N.C.	Open	—
25	REG	Connection with BASE of PNP Tr	Regulator
26	REG OUT	Output for regulator (5 V)	Regulator
27	N.C.	8, 9, 10, 27, 28, 29 are connected to PW GND (FIN)	—
28	N.C.	8, 9, 10, 27, 28, 29 are connected to PW GND (FIN)	—
29	N.C.	8, 9, 10, 27, 28, 29 are connected to PW GND (FIN)	—
30	REG STBY	Standby control for regulator	Regulator
31	IN4	Input for ch4	4ch BTL
32	IN3	Input for ch3	4ch BTL
33	STBY	Standby control for 4ch BTL	4ch BTL
34	FIN	Logic control input	H-bridge
35	RIN	Logic control input	H-bridge
36	VR	Supply voltage terminal for motor driver	H-bridge

120 dB, 192 kHz Multi-Bit DAC with Volume Control

Features

- ◆ Advanced Multi-bit Delta-Sigma Architecture
 - 120 dB Dynamic Range
 - -107 dB THD+N
 - Low Clock Jitter Sensitivity
 - Differential Analog Outputs
- ◆ PCM input
 - 102 dB of Stopband Attenuation
 - Supports Sample Rates up to 192 kHz
 - Accepts up to 24 bit Audio Data
 - Supports All Industry Standard Audio Interface Formats
 - Selectable Digital Filter Response
 - Volume Control with 1/2 dB Step Size and Soft Ramp
 - Flexible Channel Routing and Mixing
 - Selectable De-Emphasis
- ◆ Supports Stand-Alone or I²C/SPI™ Configuration
 - Embedded Level Translators
 - 1.8 V to 5 V Serial Audio Input
 - 1.8 V to 5 V Control Data Input
- ◆ Direct Stream Digital (DSD)
 - Dedicated DSD Input Pins
 - On-Chip 50 kHz Filter to Meet Scarlet Book SACD Recommendations
 - Matched PCM and DSD Analog Output Levels
 - Non-Decimating Volume Control with 1/2 dB Step Size and Soft Ramp
 - DSD Mute Detection
 - Supports Phase-Modulated Inputs
 - Optional Direct DSD Path to On-Chip Switched Capacitor Filter
- ◆ Control Output for External Muting
 - Independent Left and Right Mute Controls
 - Supports Auto Detection of Mute Output Polarity
- ◆ Typical Applications
 - DVD Players
 - SACD Players
 - A/V Receivers
 - Professional Audio Products

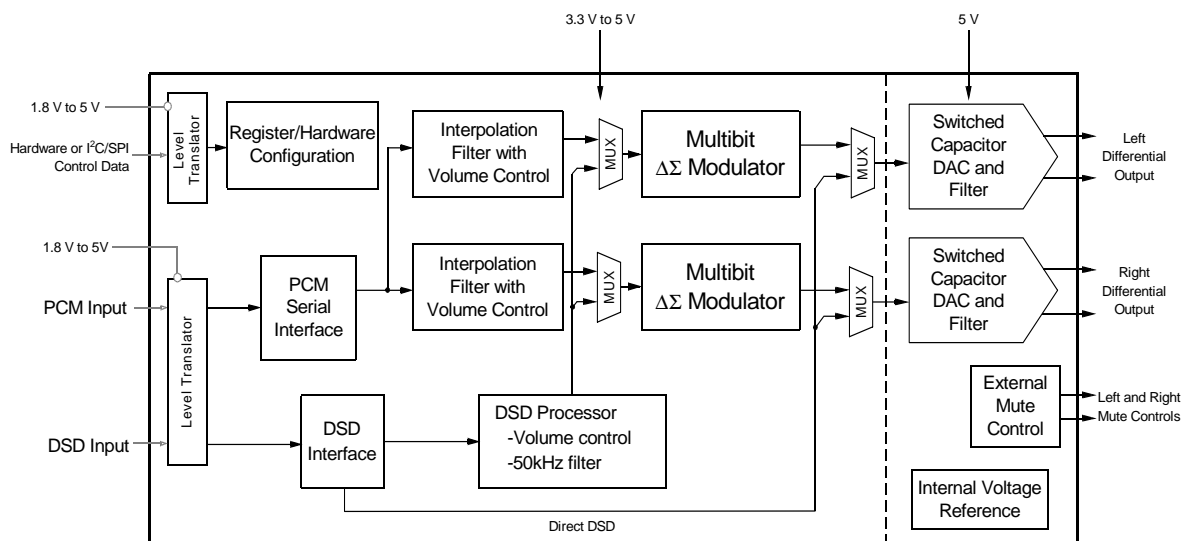

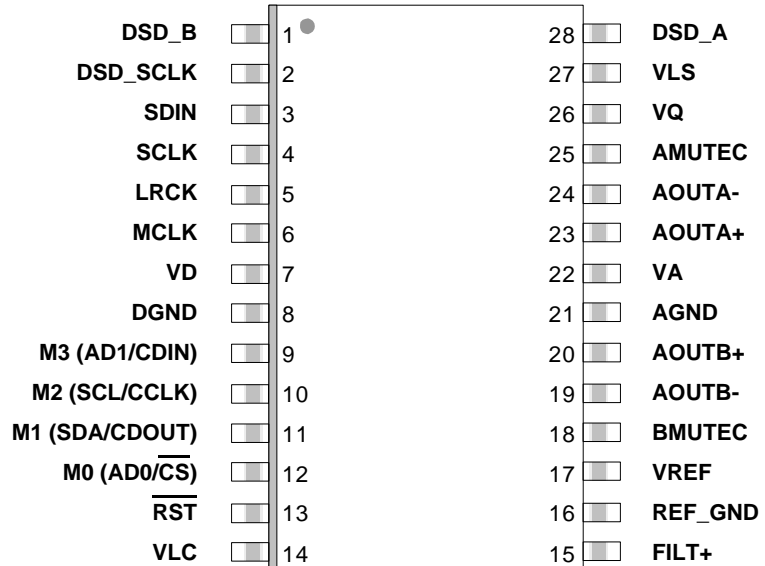

Pin Name	Pin #	Pin Description
DSD_A	28	Direct Stream Digital Input (Input) - Input for Direct Stream Digital serial audio data.
DSD_B	1	
DSD_SCLK	2	DSD Serial Clock (Input) - Serial clock for the Direct Stream Digital audio interface.
SDIN	3	Serial Audio Data Input (Input) - Input for two's complement serial audio data.
SCLK	4	Serial Clock (Input) - Serial clock for the serial audio interface.
LRCK	5	Left Right Clock (Input) - Determines which channel, Left or Right, is currently active on the serial audio data line.
MCLK	6	Master Clock (Input) - Clock source for the delta-sigma modulator and digital filters.
VD	7	Digital Power (Input) - Positive power for the digital section.
DGND	8	Digital Ground (Input) - Ground reference for the digital section.
RST	13	Reset (Input) - The device enters system reset when enabled.
VLC	14	Control Port Power (Input) - Positive power for Control Port I/O.
FILT+	15	Positive Voltage Reference (Output) - Positive reference voltage for the internal sampling circuits.
REF_GND	16	Reference Ground (Input) - Ground reference for the internal sampling circuits.
VREF	17	Voltage Reference (Input) - Positive voltage reference for the internal sampling circuits.
BMUTEC	18	Mute Control (Output) - The Mute Control pin is active during power-up initialization, muting, power-down or if the master clock to left/right clock frequency ratio is incorrect. During reset, these outputs are set to a high impedance.
AMUTEC	25	
AOUTB+	20	Differential Right Channel Analog Output (Output) - The full-scale differential analog output level is specified in the Analog Characteristics specification table.
AOUTB-	19	
AGND	21	Analog Ground (Input) - Ground reference for the analog section.
VA	22	Analog Power (Input) - Positive power for the analog section.
AOUTA+	23	Differential Left Channel Analog Output (Output) - The full-scale differential analog output level is specified in the Analog Characteristics specification table.
AOUTA-	24	
VQ	26	Quiescent Voltage (Output) - Filter connection for internal quiescent voltage.
VLS	27	Serial Audio Interface Power (Input) - Positive power for serial audio interface I/O.
Stand-Alone Mode Definitions		
M3	9	Mode Selection (Input) - Determines the operational mode of the device.
M2	10	
M1	11	
M0	12	
Control Port Mode Definitions		
AD1/CDIN	9	Address Bit 1 (I²C) / Control Data Input (SPI) (Input) - AD1 is a chip address pin in I ² C mode; CDIN is the input data line for the Control Port interface in SPI mode.
SCL/CCLK	10	Serial Control Port Clock (Input) - Serial clock for the serial Control Port.
SDA/CDOUT	11	Serial Control Data (I²C) / Control Data Output (SPI) (Input/Output) - SDA is a data I/O line in I ² C mode. CDOUT is the output data line for the Control Port interface in SPI mode.
AD0/CS	12	Address Bit 0 (I²C) / Control Port Chip Select (SPI) (Input) - AD0 is a chip address pin in I ² C mode; CS is the chip select signal for SPI format.

16. ELECTRICAL PARTS LIST

PARTS INFORMATION

RESISTORS

- 1) 00MGD05 × × × 140, Carbon film fixed resistor, ±5% 1/4W
 2) 00MGD05 × × × 160, Carbon film fixed resistor, ±5% 1/6W

① Resistance value

Examples ;

① Resistance value

0.1Ω 001	10Ω 100	1kΩ 102	100kΩ 104
0.5Ω 005	18Ω 180	2.7kΩ 272	680kΩ 684
1Ω 010	100Ω 101	10kΩ 103	1MΩ 105
6.8Ω 068	390Ω 391	22kΩ 223	4.7MΩ 475

Note : Please distinguish 1/4W from 1/6W by the shape of parts used actually.

CAPACITORS

CERAMIC CAP.

- 3) 00MDD1 × × × × 370, Ceramic capacitor
 Disc type
 Temp.coeff.P350 ~ N1000, 50V
- ② Tolerance
 Capacity value
 Tolerance

Examples ;

- ② Tolerance (Capacity deviation)
- ±0.25pF.....0
 - ±0.5pF.....1
 - ±5%.....5

* Tolerance of COMMON PARTS handled here are as follows :

- 0.5pF ~ 5pF.... ±0.25pF
- 6pF ~ 10pF.... ±0.5pF
- 12pF ~ 560pF.... ±5%

③ Capacity value

0.5pF.... 005	3pF 030	100pF.... 101
1pF.... 010	10pF 100	220pF.... 221
1.5pF.... 015	47pF 470	560pF.... 561

CERAMIC CAP.

- 4) 00MDK16 × × × × 300, High dielectric constant ceramic capacitor
 Disc type
 Temp.chara. 2B4, 50V
- ④ Capacity value

Examples ;

- ④ Capacity value
- | | | |
|---------------|-----------------|------------------|
| 100pF.... 101 | 1000pF 102 | 10000pF 103 |
| 470pF.... 471 | 2200pF 222 | |

ELECTROLY CAP. ($\frac{\square}{\square}$)

- 5) 00MEA × × × × × 10, Electrolytic capacitor
 One-way lead type, Tolerance ±20%
- ⑤ Capacity value
 Working voltage

Examples ;

- ⑤ Capacity value
- | | | |
|-----------------|----------------|----------------|
| 0.1μF 104 | 4.7μF 475 | 100μF ... 107 |
| 0.33μF 334 | 10μF 106 | 330μF ... 337 |
| 1μF 105 | 22μF 226 | 1100μF ... 118 |
| | | 2200μF ... 228 |
- ⑥ Working voltage
- | | |
|---------------|--------------|
| 6.3V 006 | 25V 025 |
| 10V 010 | 35V 035 |
| 16V 016 | 50V 050 |

FILM CAP. ($\frac{\square}{\square}$)

- 6) 00MDF15 × × × × 350 Plastic film capacitor
 One-way type, Mylar ±5% 50V
 00MDF15 × × × × 310 Plastic film capacitor
 One-way type, Mylar ±10% 50V
 00MDF16 × × × × 310 Plastic film capacitor
 One-way type, Mylar ±10% 50V
- ⑦ Capacity value

Examples ;

- ⑦ Capacity value
- | | |
|----------------------------|-----------------|
| 0.001μF (1000pF) 102 | 0.1μF 104 |
| 0.0018μF 182 | 0.56μF 564 |
| 0.01μF 103 | 1μF 105 |
| 0.015μF 153 | |

NOTE ON SAFETY FOR FUSIBLE RESISTOR :

The suppliers and their type numbers of fusible resistors are as follows;

1. KOA Corporation

Part No. (MJI)	Type No. (KOA)	Description
00MNH05 × × × 140	→ RF25S × × × × ΩJ	(±5% 1/4W)
00MNH05 × × × 120	→ RF50S × × × × ΩJ	(±5% 1/2W)
00MNH85 × × × 110	→ RF73B2A × × × × ΩJ	(±5% 1/10W)
00MNH95 × × × 140	→ RF73B2E × × × × ΩJ	(±5% 1/4W)

* Resistance value Resistance value (0.1 – 10kΩ)

2. Matsushita Electronic Components Co., Ltd

Part No. (MJI)	Type No. (MEC)	Description
00MNF05 × × × 140	→ ERD-2FCJ × × ×	(±5% 1/4W)
00MRF05 × × × 140		
00MNF02 × × × 140	→ ERD-2FCG × × ×	(±2% 1/4W)
00MRF02 × × × 140		

* Resistance value * Resistance value

Examples ;

* Resistance value

0.1Ω 001	10Ω 100	1kΩ 102	100kΩ 104
0.5Ω 005	18Ω 180	2.7kΩ 272	680kΩ 684
1Ω 010	100Ω 101	10kΩ 103	1MΩ 105
6.8Ω 068	390Ω 391	22kΩ 223	4.7MΩ 475

ABBREVIATION AND MARKS

ANT. : ANTENNA	BATT. : BATTERY
CAP. : CAPACITOR	CER. : CERAMIC
CONN. : CONNECTING	DIG. : DIGITAL
HP : HEADPHONE	MIC. : MICROPHONE
μ-PRO : MICROPROCESSOR	REC. : RECORDING
RES. : RESISTOR	SPK : SPEAKER
SW : SWITCH	TRANSF. : TRANSFORMER
TRIM. : TRIMMING	TRS. : TRANSISTOR
VAR. : VARIABLE	X'TAL : CRYSTAL

NOTE ON FUSE :

Regarding to all parts of parts code **00MFS20xxx2xx**, replace only with Wickmann-Werke GmbH, Type 372 non glass type fuse.

NOTE ON SAFETY :

Symbol **⚠** Fire or electrical shock hazard. Only original parts should be used to replaced any part marked with symbol **⚠**. Any other component substitution (other than original type), may increase risk of fire or electrical shock hazard.

安全上の注意 :

⚠がついている部品は、安全上重要な部品です。必ず指定されている部品番号の部品を使用して下さい。

P.W.B. NAME	POS. NO.	VERS. COLOR	PART NO. (FOR EUR)	PART NO. (MZ)	PART NAME	DESCRIPTION
AUDIO PWB(CUP12192-2)						
AUDIO	C601		00MOF15182540	00MOF15182540	FILM CAP.	APSV 182J 1800PF(TP) 100V POLYPROPYLENE CCMP2A182JN09T
AUDIO	C603		nsp	00MOF15121540	FILM CAP.	120PF J 100V APSV POLYPROPYLENE CCMP2A121JN09T
AUDIO	C605		nsp	00MOF15121540	FILM CAP.	120PF J 100V APSV POLYPROPYLENE CCMP2A121JN09T
AUDIO	C606		943133002360S	943133002360S	FILM CAP.	APSA0100J10100 POLYPROPYLENE CCMP2A101JN09T
AUDIO	C608		943133002360S	943133002360S	FILM CAP.	APSA0100J10100 POLYPROPYLENE CCMP2A101JN09T
AUDIO	C609		nsp	00MOA227025R0	ELECT CAP.	220UF/25V 10X20 CCEA1EROA221T
AUDIO	C610		nsp	00MOA227016Z0	ELECT CAP.	ROS-16V 221M-H5#PE-T2 (220UF 16V) CCEA1CR221T
AUDIO	C611		nsp	00MOA227016Z0	ELECT CAP.	ROS-16V 221M-H5#PE-T2 (220UF 16V) CCEA1CR221T
AUDIO	D601		nsp	00MHD20015210	DIODE	1SS133T-77 CVD1SS133MT
AUDIO	D602		nsp	00MHD20015210	DIODE	1SS133T-77 CVD1SS133MT
AUDIO	D603		nsp	00MHD20015210	DIODE	1SS133T-77 CVD1SS133MT
AUDIO	D604		nsp	00MHD20015210	DIODE	1SS133T-77 CVD1SS133MT
AUDIO	D605		nsp	00MHD20015210	DIODE	1SS133T-77 CVD1SS133MT
AUDIO	D606		nsp	00MHD20015210	DIODE	1SS133T-77 CVD1SS133MT
AUDIO	D607		nsp	00MHD20015210	DIODE	1SS133T-77 CVD1SS133MT
AUDIO	D608		nsp	00MHD20015210	DIODE	1SS133T-77 CVD1SS133MT
AUDIO	D610		nsp	00MHD20015210	DIODE	1SS133T-77 CVD1SS133MT
AUDIO	D611		nsp	00MHD20015210	DIODE	1SS133T-77 CVD1SS133MT
AUDIO	J601		nsp	nsp	CORD	SN95/PB5 0.6 C3A206
AUDIO	J602		nsp	nsp	CORD	SN95/PB5 0.6 C3A206
AUDIO	J603		nsp	nsp	CORD	SN95/PB5 0.6 C3A206
AUDIO	J604		nsp	nsp	CORD	SN95/PB5 0.6 C3A206
AUDIO	J605		nsp	nsp	CORD	SN95/PB5 0.6 C3A206
AUDIO	J606		nsp	nsp	CORD	SN95/PB5 0.6 C3A206
AUDIO	J607		nsp	nsp	CORD	SN95/PB5 0.6 C3A206
AUDIO	J608		nsp	nsp	CORD	SN95/PB5 0.6 C3A206
AUDIO	J609		nsp	nsp	CORD	SN95/PB5 0.6 C3A206
AUDIO	J610		nsp	nsp	CORD	SN95/PB5 0.6 C3A206
AUDIO	J611		nsp	nsp	CORD	SN95/PB5 0.6 C3A206
AUDIO	J612		nsp	nsp	CORD	SN95/PB5 0.6 C3A206
AUDIO	J613		nsp	nsp	CORD	SN95/PB5 0.6 C3A206
AUDIO	J614		nsp	nsp	CORD	SN95/PB5 0.6 C3A206
AUDIO	J615		nsp	nsp	CORD	SN95/PB5 0.6 C3A206
AUDIO	J616		nsp	nsp	CORD	SN95/PB5 0.6 C3A206
AUDIO	J617		nsp	nsp	CORD	SN95/PB5 0.6 C3A206
AUDIO	J618		nsp	nsp	CORD	SN95/PB5 0.6 C3A206
AUDIO	J619		nsp	nsp	CORD	SN95/PB5 0.6 C3A206
AUDIO	J620		nsp	nsp	CORD	SN95/PB5 0.6 C3A206
AUDIO	J621		nsp	nsp	CORD	SN95/PB5 0.6 C3A206
AUDIO	J622		nsp	nsp	CORD	SN95/PB5 0.6 C3A206
AUDIO	J623		nsp	nsp	CORD	SN95/PB5 0.6 C3A206
AUDIO	J624		nsp	nsp	CORD	SN95/PB5 0.6 C3A206
AUDIO	J626		nsp	nsp	CORD	SN95/PB5 0.6 C3A206
AUDIO	J627		nsp	nsp	CORD	SN95/PB5 0.6 C3A206
AUDIO	J628		nsp	nsp	CORD	SN95/PB5 0.6 C3A206
AUDIO	J629		nsp	nsp	CORD	SN95/PB5 0.6 C3A206
AUDIO	J630		nsp	nsp	CORD	SN95/PB5 0.6 C3A206
AUDIO	J631		nsp	nsp	CORD	SN95/PB5 0.6 C3A206
AUDIO	J632		nsp	nsp	CORD	SN95/PB5 0.6 C3A206
AUDIO	J633		nsp	nsp	CORD	SN95/PB5 0.6 C3A206
AUDIO	J634		nsp	nsp	CORD	SN95/PB5 0.6 C3A206
AUDIO	J636		nsp	nsp	CORD	SN95/PB5 0.6 C3A206
AUDIO	J637		nsp	nsp	CORD	SN95/PB5 0.6 C3A206
AUDIO	J639		nsp	nsp	CORD	SN95/PB5 0.6 C3A206
AUDIO	J640		nsp	nsp	CORD	SN95/PB5 0.6 C3A206
AUDIO	J641		nsp	nsp	CORD	SN95/PB5 0.6 C3A206
AUDIO	J642		nsp	nsp	CORD	SN95/PB5 0.6 C3A206
AUDIO	J643		nsp	nsp	CORD	SN95/PB5 0.6 C3A206
AUDIO	J646		nsp	nsp	CORD	SN95/PB5 0.6 C3A206
AUDIO	J647		nsp	nsp	CORD	SN95/PB5 0.6 C3A206
AUDIO	J648		nsp	nsp	CORD	SN95/PB5 0.6 C3A206
AUDIO	J649		nsp	nsp	CORD	SN95/PB5 0.6 C3A206
AUDIO	J650		nsp	nsp	CORD	SN95/PB5 0.6 C3A206
AUDIO	J651		nsp	nsp	CORD	SN95/PB5 0.6 C3A206
AUDIO	J652		nsp	nsp	CORD	SN95/PB5 0.6 C3A206
AUDIO	J654		nsp	nsp	CORD	SN95/PB5 0.6 C3A206
AUDIO	J655		nsp	nsp	CORD	SN95/PB5 0.6 C3A206
AUDIO	J656		nsp	nsp	CORD	SN95/PB5 0.6 C3A206
AUDIO	J659		nsp	nsp	CORD	SN95/PB5 0.6 C3A206
AUDIO	Q601		00MHF203691B0	00MHF203691B0	F.E.T.	2SK369 BL VGDS-40V PD0.4W HVT2SK369BLT
AUDIO	Q602		00MHF203691B0	00MHF203691B0	F.E.T.	2SK369 BL VGDS-40V PD0.4W HVT2SK369BLT
AUDIO	Q603		00MHT800931A0	00MHT800931A0	TRS.	KTC3200GR-AT/P HVTKTC3200GRT
AUDIO	Q604		00MHT600121A0	00MHT600121A0	TRS.	KTA1268GR HVTKTA1268GRT
AUDIO	Q605		00MHT600121A0	00MHT600121A0	TRS.	KTA1268GR HVTKTA1268GRT
AUDIO	Q606		00MHT800931A0	00MHT800931A0	TRS.	KTC3200GR-AT/P HVTKTC3200GRT

NOTE : "nsp" PART IS LISTED FOR REFERENCE ONLY, D&M WILL NOT SUPPLY THESE PARTS.

P.W.B. NAME	POS. NO.	VERS. COLOR	PART NO. (FOR EUR)	PART NO. (MZ)	PART NAME	DESCRIPTION	
AUDIO	Q607		00MHT800931A0	00MHT800931A0	TRS.	KTC3200GR-AT/P	HVTKTC3200GRT
AUDIO	Q608		00MHT600121A0	00MHT600121A0	TRS.	KTA1268GR	HVTKTA1268GRT
AUDIO	Q609		00MHT600121A0	00MHT600121A0	TRS.	KTA1268GR	HVTKTA1268GRT
AUDIO	Q610		00MHT800931A0	00MHT800931A0	TRS.	KTC3200GR-AT/P	HVTKTC3200GRT
AUDIO	Q611		00MHT800931A0	00MHT800931A0	TRS.	KTC3200GR-AT/P	HVTKTC3200GRT
AUDIO	Q612		00MHT800931A0	00MHT800931A0	TRS.	KTC3200GR-AT/P	HVTKTC3200GRT
AUDIO	Q613		00MHT600121A0	00MHT600121A0	TRS.	KTA1268GR	HVTKTA1268GRT
AUDIO	Q614		00MBA10002000	00MBA10002000	TRS.	KRA104M	HVTKRA104MT
AUDIO	Q615		90M-BA001460R	90M-BA001460R	TRS.	KRC107M	HVTKRC107MT
AUDIO	Q616		00MHT805501B0	00MHT805501B0	TRS.	KTC2874B	HVTKTC2874BT
AUDIO	Q617		00MHT805501B0	00MHT805501B0	TRS.	KTC2874B	HVTKTC2874BT
AUDIO	R601		00MGD05102160	00MGD05102160	RES.	1K OHM 1/6W J CARBON	CRD20TJ102T
AUDIO	R602		00MGD05822160	00MGD05822160	RES.	8.2K OHM 1/6W J CARBON	CRD20TJ822T
AUDIO	R603		00MGD05822160	00MGD05822160	RES.	8.2K OHM 1/6W J CARBON	CRD20TJ822T
AUDIO	R604		00MGD05512160	00MGD05512160	RES.	5.1K OHM J CARBON	CRD20TJ512T
AUDIO	R605		00MGD05010160	00MGD05010160	RES.	1 OHM 1/6W J CARBON	CRD20TJ1R0T
AUDIO	R606		00MGD05102160	00MGD05102160	RES.	1K OHM 1/6W J CARBON	CRD20TJ102T
AUDIO	R607		00MGD05822160	00MGD05822160	RES.	8.2K OHM 1/6W J CARBON	CRD20TJ822T
AUDIO	R608		00MGD05822160	00MGD05822160	RES.	8.2K OHM 1/6W J CARBON	CRD20TJ822T
AUDIO	R609		00MGD05512160	00MGD05512160	RES.	5.1K OHM J CARBON	CRD20TJ512T
AUDIO	R610		00MGD05010160	00MGD05010160	RES.	1 OHM 1/6W J CARBON	CRD20TJ1R0T
AUDIO	R611		00MGD05680160	00MGD05680160	RES.	68 OHM 1/6W J CARBON	CRD20TJ680T
AUDIO	R612		00MGD05561160	00MGD05561160	RES.	560 OHM 1/6W J CARBON	CRD20TJ561T
AUDIO	R613		00MGD05121160	00MGD05121160	RES.	120 OHM 1/6W J CARBON	CRD20TJ121T
AUDIO	R614		00MGD05121160	00MGD05121160	RES.	120 OHM 1/6W J CARBON	CRD20TJ121T
AUDIO	R615		00MGD05333160	00MGD05333160	RES.	33K OHM 1/6W J CARBON	CRD20TJ333T
AUDIO	R616		00MGD05561160	00MGD05561160	RES.	560 OHM 1/6W J CARBON	CRD20TJ561T
AUDIO	R617		00MGD05101160	00MGD05101160	RES.	100 OHM 1/6W J CARBON	CRD20TJ101T
AUDIO	R618		00MGD05473160	00MGD05473160	RES.	47K OHM 1/6W J CARBON	CRD20TJ473T
AUDIO	R619		00MGD05271160	00MGD05271160	RES.	270 OHM 1/6W J CARBON	CRD20TJ271T
AUDIO	R620		00MGD05330160	00MGD05330160	RES.	33 OHM 1/6W J CARBON	CRD20TJ330T
AUDIO	R621		00MGD05330160	00MGD05330160	RES.	33 OHM 1/6W J CARBON	CRD20TJ330T
AUDIO	R622		00MGD05271160	00MGD05271160	RES.	270 OHM 1/6W J CARBON	CRD20TJ271T
AUDIO	R623		00MGD05330160	00MGD05330160	RES.	33 OHM 1/6W J CARBON	CRD20TJ330T
AUDIO	R624		00MGD05330160	00MGD05330160	RES.	33 OHM 1/6W J CARBON	CRD20TJ330T
AUDIO	R625		00MGD05473160	00MGD05473160	RES.	47K OHM 1/6W J CARBON	CRD20TJ473T
AUDIO	R626		00MGD05680160	00MGD05680160	RES.	68 OHM 1/6W J CARBON	CRD20TJ680T
AUDIO	R627		00MGD05221160	00MGD05221160	RES.	220 OHM 1/6W J CARBON	CRD20TJ221T
AUDIO	R628		00MGD05472160	00MGD05472160	RES.	4.7K OHM 1/6W J CARBON	CRD20TJ472T
AUDIO	R629		00MGD05680160	00MGD05680160	RES.	68 OHM 1/6W J CARBON	CRD20TJ680T
AUDIO	R630		00MGD05472160	00MGD05472160	RES.	4.7K OHM 1/6W J CARBON	CRD20TJ472T
AUDIO	R631		00MGD05680160	00MGD05680160	RES.	68 OHM 1/6W J CARBON	CRD20TJ680T
AUDIO	R632		00MGD05122160	00MGD05122160	RES.	1.2K OHM 1/6W J CARBON	CRD20TJ122T
AUDIO	R633		00MGD05474160	00MGD05474160	RES.	470K OHM 1/6W J CARBON	CRD20TJ474T
AUDIO	BN42		nsp	nsp	WIRE	WIREASSY(LOCK,13P,80MM,2.0MM)	CWB1D01308047
AUDIO	BN43		nsp	nsp	WIRE	WIREASSY(LOCK,5P,80MM,2.5MM)	CWB1D00508058
AUDIO	BN44		nsp	nsp	WIRE	WIREASSY(LOCK,5P,80MM,2.5MM)	CWB1D00508058
AUDIO	BN45		nsp	nsp	WIRE	WIREASSY(LOCK,13P,80MM,2.0MM)	CWB1D01308047
AUDIO	C434		nsp	00MOF15121540	FILM CAP.	120PF J 100V APSV POLYPROPYLENE	CCMP2A121JN09T
AUDIO	C701		00MOF15182540	00MOF15182540	FILM CAP.	APSV 182J 1800PF(TP) 100V POLYPROPYLENE	CCMP2A182JN09T
AUDIO	C703		nsp	00MOF15121540	FILM CAP.	120PF J 100V APSV POLYPROPYLENE	CCMP2A121JN09T
AUDIO	C705		nsp	00MOF15121540	FILM CAP.	120PF J 100V APSV POLYPROPYLENE	CCMP2A121JN09T
AUDIO	C706		943133002360S	943133002360S	FILM CAP.	APSA0100J10100 POLYPROPYLENE	CCMP2A101JN09T
AUDIO	C708		943133002360S	943133002360S	FILM CAP.	APSA0100J10100 POLYPROPYLENE	CCMP2A101JN09T
AUDIO	C709		nsp	00MOA227025R0	ELECT CAP.	220UF/25V 10X20	CCEA1EROA221T
AUDIO	C710		nsp	00MOA227016Z0	ELECT CAP.	ROS-16V 221M-H5#PE-T2 (220UF 16V)	CCEA1CR221T
AUDIO	C711		nsp	00MOA227016Z0	ELECT CAP.	ROS-16V 221M-H5#PE-T2 (220UF 16V)	CCEA1CR221T
AUDIO	C751		nsp	00MOA10701620	ELECT CAP.	100UF 16V	CCEA1CH101T
AUDIO	C752		nsp	nsp	CER. CAP.	0.1UF 50V Z CERAMIC	CCBS1H104ZFT
AUDIO	C753		nsp	00MOA10701620	ELECT CAP.	100UF 16V	CCEA1CH101T
AUDIO	C754		nsp	nsp	CER. CAP.	0.1UF 50V Z CERAMIC	CCBS1H104ZFT
AUDIO	C755		nsp	00MOA227025R0	ELECT CAP.	220UF/25V 10X20	CCEA1EROA221T
AUDIO	C756		nsp	00MOA33505020	ELECT CAP.	3.3UF 50V	CCEA1HH3R3T
AUDIO	C757		nsp	00MOA227025R0	ELECT CAP.	220UF/25V 10X20	CCEA1EROA221T
AUDIO	C758		nsp	nsp	CER. CAP.	0.1UF 50V Z CERAMIC	CCBS1H104ZFT
AUDIO	C759		nsp	nsp	CER. CAP.	0.1UF 50V Z CERAMIC	CCBS1H104ZFT
AUDIO	C760		nsp	nsp	CER. CAP.	0.1UF 50V Z CERAMIC	CCBS1H104ZFT
AUDIO	C761		nsp	90M-OA000330R	ELECT CAP.	33UF 50V	CCEA1HH330T
AUDIO	C762		nsp	90M-OA000330R	ELECT CAP.	33UF 50V	CCEA1HH330T
AUDIO	C763		nsp	00MOA10701620	ELECT CAP.	100UF 16V	CCEA1CH101T
AUDIO	C764		nsp	nsp	CER. CAP.	0.1UF 50V Z CERAMIC	CCBS1H104ZFT
AUDIO	C765		nsp	nsp	CER. CAP.	0.1UF 50V Z CERAMIC	CCBS1H104ZFT
AUDIO	C790		nsp	nsp	CER. CAP.	0.1UF 50V Z CERAMIC	CCBS1H104ZFT
AUDIO	C793		nsp	nsp	CER. CAP.	0.1UF 50V Z CERAMIC	CCBS1H104ZFT
AUDIO	CN81		nsp	nsp	CONN.	9P STRAIGHT 00906-0030	CJP09GA19ZY
AUDIO	D701		nsp	00MHD20015210	DIODE	1SS133T-77	CVD1SS133MT

NOTE : "nsp" PART IS LISTED FOR REFERENCE ONLY, D&M WILL NOT SUPPLY THESE PARTS.

P.W.B. NAME	POS. NO.	VERS. COLOR	PART NO. (FOR EUR)	PART NO. (MZ)	PART NAME	DESCRIPTION	
AUDIO	D702		nsp	00MHD20015210	DIODE	1SS133T-77	CVD1SS133MT
AUDIO	D703		nsp	00MHD20015210	DIODE	1SS133T-77	CVD1SS133MT
AUDIO	D704		nsp	00MHD20015210	DIODE	1SS133T-77	CVD1SS133MT
AUDIO	D705		nsp	00MHD20015210	DIODE	1SS133T-77	CVD1SS133MT
AUDIO	D706		nsp	00MHD20015210	DIODE	1SS133T-77	CVD1SS133MT
AUDIO	D707		nsp	00MHD20015210	DIODE	1SS133T-77	CVD1SS133MT
AUDIO	D708		nsp	00MHD20015210	DIODE	1SS133T-77	CVD1SS133MT
AUDIO	D710		nsp	00MHD20015210	DIODE	1SS133T-77	CVD1SS133MT
AUDIO	D711		nsp	00MHD20015210	DIODE	1SS133T-77	CVD1SS133MT
AUDIO	GND1		nsp	nsp	TERMINAL	EARTH PLATE MET37-0002	HJT1A025
AUDIO	HF91		nsp	nsp	CONN.	HOLDER FUSE	KJCF5S
AUDIO	HF92		nsp	nsp	CONN.	HOLDER FUSE	KJCF5S
AUDIO	IC75		90M-HC109330R	90M-HC109330R	IC	CS4398CZ	HVIC54398CZ
AUDIO	IC76		00MHC3890599F	00MHC3890599F	IC	KIA7805API	HVIA7805API
AUDIO	IC77		90M-HC900150R	90M-HC900150R	IC	KIA1117S/F33 REGULATOR(SOT-223)	CVIKIA1117S33
AUDIO	▲ IC94		943231007200M	943231007200M	TC	REGULATOR(6VOUTPUTLOWDROP)	CVIKIA78R06PI
AUDIO	J751		nsp	nsp	CORD	SN95/PB5 0.6	C3A206
AUDIO	J752		nsp	nsp	CORD	SN95/PB5 0.6	C3A206
AUDIO	JK61		943643002370S	943643002370S	TERMINAL	CINCH 1P WHITE (GL)	CJJ4M064Z
AUDIO	JK71		943643002380S	943643002380S	TERMINAL	CINCH 1P RED (GL)	CJJ4M065Z
AUDIO	L751		90M-FN000090R	90M-FN000090R	EMI FILTER	BEAD	KLZ9H001Z
AUDIO	L752		nsp	nsp	CORD	SN95/PB5 0.6	C3A206
AUDIO	Q701		00MHF203691B0	00MHF203691B0	F.E.T.	2SK369 BL VGDS-40V PD0.4W	HVT2SK369BLT
AUDIO	Q702		00MHF203691B0	00MHF203691B0	F.E.T.	2SK369 BL VGDS-40V PD0.4W	HVT2SK369BLT
AUDIO	Q703		00MHT800931A0	00MHT800931A0	TRS.	KTC3200GR-AT/P	HVTKTC3200GRT
AUDIO	Q704		00MHT600121A0	00MHT600121A0	TRS.	KTA1268GR	HVTKTA1268GRT
AUDIO	Q705		00MHT600121A0	00MHT600121A0	TRS.	KTA1268GR	HVTKTA1268GRT
AUDIO	Q706		00MHT800931A0	00MHT800931A0	TRS.	KTC3200GR-AT/P	HVTKTC3200GRT
AUDIO	Q707		00MHT800931A0	00MHT800931A0	TRS.	KTC3200GR-AT/P	HVTKTC3200GRT
AUDIO	Q708		00MHT600121A0	00MHT600121A0	TRS.	KTA1268GR	HVTKTA1268GRT
AUDIO	Q709		00MHT600121A0	00MHT600121A0	TRS.	KTA1268GR	HVTKTA1268GRT
AUDIO	Q710		00MHT800931A0	00MHT800931A0	TRS.	KTC3200GR-AT/P	HVTKTC3200GRT
AUDIO	Q711		00MHT800931A0	00MHT800931A0	TRS.	KTC3200GR-AT/P	HVTKTC3200GRT
AUDIO	Q712		00MHT800931A0	00MHT800931A0	TRS.	KTC3200GR-AT/P	HVTKTC3200GRT
AUDIO	Q713		00MHT600121A0	00MHT600121A0	TRS.	KTA1268GR	HVTKTA1268GRT
AUDIO	Q714		00MBA10002000	00MBA10002000	TRS.	KRA104M	HVTKRA104MT
AUDIO	Q715		90M-BA001460R	90M-BA001460R	TRS.	KRC107M	HVTKRC107MT
AUDIO	Q716		00MHT805501B0	00MHT805501B0	TRS.	KTC2874B	HVTKTC2874BT
AUDIO	Q717		00MHT805501B0	00MHT805501B0	TRS.	KTC2874B	HVTKTC2874BT
AUDIO	R701		00MGD05102160	00MGD05102160	RES.	1K OHM 1/6W J CARBON	CRD20TJ102T
AUDIO	R702		00MGD05822160	00MGD05822160	RES.	8.2K OHM 1/6W J CARBON	CRD20TJ822T
AUDIO	R703		00MGD05822160	00MGD05822160	RES.	8.2K OHM 1/6W J CARBON	CRD20TJ822T
AUDIO	R704		00MGD05512160	00MGD05512160	RES.	5.1K OHM J CARBON	CRD20TJ512T
AUDIO	R705		00MGD05010160	00MGD05010160	RES.	1 OHM 1/6W J CARBON	CRD20TJ1R0T
AUDIO	R706		00MGD05102160	00MGD05102160	RES.	1K OHM 1/6W J CARBON	CRD20TJ102T
AUDIO	R707		00MGD05822160	00MGD05822160	RES.	8.2K OHM 1/6W J CARBON	CRD20TJ822T
AUDIO	R708		00MGD05822160	00MGD05822160	RES.	8.2K OHM 1/6W J CARBON	CRD20TJ822T
AUDIO	R709		00MGD05512160	00MGD05512160	RES.	5.1K OHM J CARBON	CRD20TJ512T
AUDIO	R710		00MGD05010160	00MGD05010160	RES.	1 OHM 1/6W J CARBON	CRD20TJ1R0T
AUDIO	R711		00MGD05680160	00MGD05680160	RES.	68 OHM 1/6W J CARBON	CRD20TJ680T
AUDIO	R712		00MGD05561160	00MGD05561160	RES.	560 OHM 1/6W J CARBON	CRD20TJ561T
AUDIO	R713		00MGD05121160	00MGD05121160	RES.	120 OHM 1/6W J CARBON	CRD20TJ121T
AUDIO	R714		00MGD05121160	00MGD05121160	RES.	120 OHM 1/6W J CARBON	CRD20TJ121T
AUDIO	R715		00MGD05333160	00MGD05333160	RES.	33K OHM 1/6W J CARBON	CRD20TJ333T
AUDIO	R716		00MGD05561160	00MGD05561160	RES.	560 OHM 1/6W J CARBON	CRD20TJ561T
AUDIO	R717		00MGD05101160	00MGD05101160	RES.	100 OHM 1/6W J CARBON	CRD20TJ101T
AUDIO	R718		00MGD05473160	00MGD05473160	RES.	47K OHM 1/6W J CARBON	CRD20TJ473T
AUDIO	R719		00MGD05271160	00MGD05271160	RES.	270 OHM 1/6W J CARBON	CRD20TJ271T
AUDIO	R720		00MGD05330160	00MGD05330160	RES.	33 OHM 1/6W J CARBON	CRD20TJ330T
AUDIO	R721		00MGD05330160	00MGD05330160	RES.	33 OHM 1/6W J CARBON	CRD20TJ330T
AUDIO	R722		00MGD05271160	00MGD05271160	RES.	270 OHM 1/6W J CARBON	CRD20TJ271T
AUDIO	R723		00MGD05330160	00MGD05330160	RES.	33 OHM 1/6W J CARBON	CRD20TJ330T
AUDIO	R724		00MGD05330160	00MGD05330160	RES.	33 OHM 1/6W J CARBON	CRD20TJ330T
AUDIO	R725		00MGD05473160	00MGD05473160	RES.	47K OHM 1/6W J CARBON	CRD20TJ473T
AUDIO	R726		00MGD05680160	00MGD05680160	RES.	68 OHM 1/6W J CARBON	CRD20TJ680T
AUDIO	R727		00MGD05221160	00MGD05221160	RES.	220 OHM 1/6W J CARBON	CRD20TJ221T
AUDIO	R728		00MGD05472160	00MGD05472160	RES.	4.7K OHM 1/6W J CARBON	CRD20TJ472T
AUDIO	R729		00MGD05680160	00MGD05680160	RES.	68 OHM 1/6W J CARBON	CRD20TJ680T
AUDIO	R730		00MGD05472160	00MGD05472160	RES.	4.7K OHM 1/6W J CARBON	CRD20TJ472T
AUDIO	R731		00MGD05680160	00MGD05680160	RES.	68 OHM 1/6W J CARBON	CRD20TJ680T
AUDIO	R732		00MGD05122160	00MGD05122160	RES.	1.2K OHM 1/6W J CARBON	CRD20TJ122T
AUDIO	R733		00MGD05474160	00MGD05474160	RES.	470K OHM 1/6W J CARBON	CRD20TJ474T
AUDIO	R751		00MGD05010160	00MGD05010160	RES.	1 OHM 1/6W J CARBON	CRD20TJ1R0T
AUDIO	R752		00MGD05010160	00MGD05010160	RES.	1 OHM 1/6W J CARBON	CRD20TJ1R0T
AUDIO	R753		00MGD05010160	00MGD05010160	RES.	1 OHM 1/6W J CARBON	CRD20TJ1R0T
AUDIO	R754		00MGD05010160	00MGD05010160	RES.	1 OHM 1/6W J CARBON	CRD20TJ1R0T

NOTE : "nsp" PART IS LISTED FOR REFERENCE ONLY, D&M WILL NOT SUPPLY THESE PARTS.

P.W.B. NAME	POS. NO.	VERS. COLOR	PART NO. (FOR EUR)	PART NO. (MZ)	PART NAME	DESCRIPTION
AUDIO	R755		00MGD05010160	00MGD05010160	RES.	1 OHM 1/6W J CARBON CRD20TJ1R0T
AUDIO	R756		00MGD05010160	00MGD05010160	RES.	1 OHM 1/6W J CARBON CRD20TJ1R0T
AUDIO	R757		00MGD05102160	00MGD05102160	RES.	1K OHM 1/6W J CARBON CRD20TJ102T
AUDIO	R760		nsp	nsp	CORD	SN95/PB5 0.6 C3A206
AUDIO	R761		nsp	nsp	CORD	SN95/PB5 0.6 C3A206
AUDIO		FN	nsp	nsp	PCB	CD6003/FCDAUDIO+POWERPCBASSY COP12192C
AUDIO		FN	nsp	nsp	PCB	CD6003/FCDAUDIO+POWERPCBAUTOASSY CIP12192C
AUDIO		K1SG	nsp	nsp	PCB	CD6003/KCDAUDIO+POWERPCBASSY COP12192D
AUDIO		K1SG	nsp	nsp	PCB	CD6003/KCDAUDIO+POWERPCBAUTOASSY CIP12192D
AUDIO		N1	nsp	nsp	PCB	CD6003/NCDAUDIO+POWERPCBAUTOASSY CIP12192B
AUDIO			nsp	nsp	PCB	PCB,AUDIO+POWERCD6003(330*247,FR1/1) CUP12192Z
FRONT. PWB(CUP12191Z)						
FRONT		N1B	nsp	nsp	PCB	CD6003CDFRONTPCBAUTOASSY CIP12191B
FRONT		N1B	nsp	nsp	PCB	PCB,FRONT+HPCD6003(331*197,FR1/2) CUP12191Z
FRONT	BK81(19)		nsp	nsp	PLATE	PLATE,EARTH CMC1A348
FRONT	BN23		nsp	nsp	WAFER	WIREASSY(5P,2.0MM,350MM,Shield) CWB1C905350EN001
FRONT	BN51		nsp	nsp	CORD	WIRE ASSY CWB1B905050EN
FRONT	CN51		nsp	nsp	CONN.	5P WAFER 20017WR-05 CJP05GB46ZY
FRONT	IC81		00MHC10102090	00MHC10102090	IC	NJM2068M HVINJM2068MTE1
FRONT	JW54		nsp	nsp	CORD	WIRE ASSY CWE7202100AR
FRONT		FN	nsp	nsp	PCB	CD6003CDFRONTPCBAUTOASSY CIP12191B
FRONT		FN	nsp	nsp	PCB	PCB,FRONT+HPCD6003(331*197,FR1/2) CUP12191Z
FRONT		K1SG	nsp	nsp	PCB	CD6003CDFRONTPCBAUTOASSY CIP12191B
FRONT		K1SG	nsp	nsp	PCB	PCB,FRONT+HPCD6003(331*197,FR1/2) CUP12191Z
FRONT		N1SG	nsp	nsp	PCB	CD6003CDFRONTPCBAUTOASSY CIP12191B
FRONT		N1SG	nsp	nsp	PCB	PCB,FRONT+HPCD6003(331*197,FR1/2) CUP12191Z
FRONT1. PWB(CUP12191Z-1)						
FRONT1	BK51(13)		nsp	nsp	BRACKET	BRACKET, FIP CMD1A721
FRONT1	BK52(13)		nsp	nsp	BRACKET	BRACKET, FIP CMD1A721
FRONT1	C501		nsp	nsp	CER. CAP.	0.1UF 50V Z CERAMIC CCBS1H104ZFT
FRONT1	C502		nsp	nsp	CER. CAP.	0.1UF 50V Z CERAMIC CCBS1H104ZFT
FRONT1	C503		00MEJ47601640	00MEJ47601640	ELECT CAP.	47 UF 16V KS CCEA1CKS470T
FRONT1	C504		nsp	nsp	CER. CAP.	0.1UF 50V Z CERAMIC CCBS1H104ZFT
FRONT1	C505		nsp	nsp	CER. CAP.	0.1UF 50V Z CERAMIC CCBS1H104ZFT
FRONT1	C506		00MEJ47601640	00MEJ47601640	ELECT CAP.	47 UF 16V KS CCEA1CKS470T
FRONT1	C507		nsp	nsp	CER. CAP.	0.1UF 50V Z CERAMIC CCBS1H104ZFT
FRONT1	C508		nsp	nsp	CER. CAP.	22PF 50V J CCBS1H220JCT
FRONT1	C509		nsp	nsp	CER. CAP.	22PF 50V J CCBS1H220JCT
FRONT1	C510		nsp	nsp	CER. CAP.	0.1UF 50V Z CERAMIC CCBS1H104ZFT
FRONT1	CN21		nsp	nsp	CONN.	19P WAFER FFC FCZ100E-19SSK CJP19GA117ZY
FRONT1	D503		90M-HI101120R	90M-HI101120R	L.E.D.	SLR325VRA47 KVDLSLR325VRA47
FRONT1	FL51(12)		943172007220M	943172007220M	FIP	F.I.P.CD6003FUTABA(13BT-237INK) CFL13BT237INK
FRONT1	J503		nsp	nsp	CORD	SN95/PB5 0.6 C3A206
FRONT1	J504		nsp	nsp	CORD	SN95/PB5 0.6 C3A206
FRONT1	J505		nsp	nsp	CORD	SN95/PB5 0.6 C3A206
FRONT1	J506		nsp	nsp	CORD	SN95/PB5 0.6 C3A206
FRONT1	J507		nsp	nsp	CORD	SN95/PB5 0.6 C3A206
FRONT1	J508		nsp	nsp	CORD	SN95/PB5 0.6 C3A206
FRONT1	J509		nsp	nsp	CORD	SN95/PB5 0.6 C3A206
FRONT1	J510		nsp	nsp	CORD	SN95/PB5 0.6 C3A206
FRONT1	J511		nsp	nsp	CORD	SN95/PB5 0.6 C3A206
FRONT1	J512		nsp	nsp	CORD	SN95/PB5 0.6 C3A206
FRONT1	J513		nsp	nsp	CORD	SN95/PB5 0.6 C3A206
FRONT1	J514		nsp	nsp	CORD	SN95/PB5 0.6 C3A206
FRONT1	J515		nsp	nsp	CORD	SN95/PB5 0.6 C3A206
FRONT1	J516		nsp	nsp	CORD	SN95/PB5 0.6 C3A206
FRONT1	J517		nsp	nsp	CORD	SN95/PB5 0.6 C3A206
FRONT1	J518		nsp	nsp	CORD	SN95/PB5 0.6 C3A206
FRONT1	J519		nsp	nsp	CORD	SN95/PB5 0.6 C3A206
FRONT1	J520		nsp	nsp	CORD	SN95/PB5 0.6 C3A206
FRONT1	J521		nsp	nsp	CORD	SN95/PB5 0.6 C3A206
FRONT1	J522		nsp	nsp	CORD	SN95/PB5 0.6 C3A206
FRONT1	J523		nsp	nsp	CORD	SN95/PB5 0.6 C3A206
FRONT1	J526		nsp	nsp	CORD	SN95/PB5 0.6 C3A206
FRONT1	J591		nsp	nsp	CORD	SN95/PB5 0.6 C3A206
FRONT1	JK51		943643001320S	943643001320S	TERMINAL	USB JACK STRAIGHT BLACK CJJ9X006Z
FRONT1	L501		90M-FN000090R	90M-FN000090R	EMI FILTER	BEAD KLZ9H001Z
FRONT1	L502		90M-FN000090R	90M-FN000090R	EMI FILTER	BEAD KLZ9H001Z
FRONT1	L503		90M-FN000090R	90M-FN000090R	EMI FILTER	BEAD KLZ9H001Z
FRONT1	L504		90M-FN000090R	90M-FN000090R	EMI FILTER	BEAD KLZ9H001Z
FRONT1	Q502		90M-BA001460R	90M-BA001460R	TRS.	KRC107M HVTKRC107MT
FRONT1	R503		00MGD05101160	00MGD05101160	RES.	100 OHM 1/6W J CARBON CRD20TJ101T
FRONT1	R504		00MGD05271160	00MGD05271160	RES.	270 OHM 1/6W J CARBON CRD20TJ271T
FRONT1	R505		00MGD05333160	00MGD05333160	RES.	33K OHM 1/6W J CARBON CRD20TJ333T

NOTE : "nsp" PART IS LISTED FOR REFERENCE ONLY, D&M WILL NOT SUPPLY THESE PARTS.

P.W.B. NAME	POS. NO.	VERS. COLOR	PART NO. (FOR EUR)	PART NO. (MZ)	PART NAME	DESCRIPTION
FRONT1	R506		00MGD05100160	00MGD05100160	RES.	10 OHM 1/6W J CARBON CRD20TJ100T
FRONT1	R507		00MGD05100160	00MGD05100160	RES.	10 OHM 1/6W J CARBON CRD20TJ100T
FRONT1	R508		00MGD05182160	00MGD05182160	RES.	1.8K OHM 1/6W J CARBON CRD20TJ182T
FRONT1	R509		00MGD05681160	00MGD05681160	RES.	680 OHM 1/6W J CARBON CRD20TJ681T
FRONT1	R510		00MGD05331160	00MGD05331160	RES.	330 OHM 1/6W J CARBON CRD20TJ331T
FRONT1	R511		00MGD05102160	00MGD05102160	RES.	1K OHM 1/6W J CARBON CRD20TJ102T
FRONT1	R512		00MGD05331160	00MGD05331160	RES.	1.8K OHM 1/6W J CARBON CRD20TJ182T
FRONT1	R513		00MGD05681160	00MGD05681160	RES.	680 OHM 1/6W J CARBON CRD20TJ681T
FRONT1	R514		00MGD05331160	00MGD05331160	RES.	330 OHM 1/6W J CARBON CRD20TJ331T
FRONT1	R515		00MGD05102160	00MGD05102160	RES.	1K OHM 1/6W J CARBON CRD20TJ102T
FRONT1	R516		00MGD05331160	00MGD05331160	RES.	33K OHM 1/6W J CARBON CRD20TJ333T
FRONT1	RS51		00MHW10004210	00MHW10004210	PHOTO UNIT	RPM6936-V4 CRVRPM6936V4
FRONT1	S502		90M-SP001400R	90M-SP001400R	PUSH SW	TACT SW EVQ22505R CST1A023ZT
FRONT1	S503		90M-SP001400R	90M-SP001400R	PUSH SW	TACT SW EVQ22505R CST1A023ZT
FRONT1	S504		90M-SP001400R	90M-SP001400R	PUSH SW	TACT SW EVQ22505R CST1A023ZT
FRONT1	S505		90M-SP001400R	90M-SP001400R	PUSH SW	TACT SW EVQ22505R CST1A023ZT
FRONT1	S506		90M-SP001400R	90M-SP001400R	PUSH SW	TACT SW EVQ22505R CST1A023ZT
FRONT1	S507		90M-SP001400R	90M-SP001400R	PUSH SW	TACT SW EVQ22505R CST1A023ZT
FRONT1	S508		90M-SP001400R	90M-SP001400R	PUSH SW	TACT SW EVQ22505R CST1A023ZT
FRONT2. PWB(CUP12191Z-2)						
FRONT2	D501		263710016400S	263710016400S	L.E.D.	SLI-325URT31W TP CVDSL1325URT31WT055
FRONT2	J524		nsp	nsp	CORD	SN95/PB5 0.6 C3A206
FRONT2	J525		nsp	nsp	CORD	SN95/PB5 0.6 C3A206
FRONT2	Q501		90M-BA001460R	90M-BA001460R	TRS.	KRC107M HVTKRC107MT
FRONT2	R501		00MGD05821160	00MGD05821160	RES.	820 OHM 1/6W J CARBON CRD20TJ821T
FRONT2	R502		00MGD05103160	00MGD05103160	RES.	10K OHM 1/6W J CARBON CRD20TJ103T
FRONT2	R517		00MGD05103160	00MGD05103160	RES.	10K OHM 1/6W J CARBON CRD20TJ103T
FRONT2	S501		90M-SP001400R	90M-SP001400R	PUSH SW	TACT SW EVQ22505R CST1A023ZT
H/P/PWB(CUP12191Z-3)						
H/P	BK81		nsp	nsp	BRACKET	BRACKET FOR PWB CMD1A569
H/P	BN81		nsp	nsp	CORD	WIRE ASSY 9P 280MM CWZCD5003BN81ZA
H/P	C801		00MOA22701620	00MOA22701620	ELECT CAP.	220UF 16V CCEA1CH221T
H/P	C802		00MOA22701620	00MOA22701620	ELECT CAP.	220UF 16V CCEA1CH221T
H/P	C803		00MOA10702520	00MOA10702520	ELECT CAP.	100UF 25V CCEA1EH101T
H/P	C804		00MOA10702520	00MOA10702520	ELECT CAP.	100UF 25V CCEA1EH101T
H/P	C805		nsp	nsp	CER. CAP.	1000PF 50V B CERAMIC CCBS1H102KBT
H/P	C806		nsp	nsp	CER. CAP.	1000PF 50V B CERAMIC CCBS1H102KBT
H/P	C807		00MOA10702520	00MOA10702520	ELECT CAP.	100UF 25V CCEA1EH101T
H/P	C808		00MOA10702520	00MOA10702520	ELECT CAP.	100UF 25V CCEA1EH101T
H/P	C809		00MOA10702520	00MOA10702520	ELECT CAP.	100UF 25V CCEA1EH101T
H/P	C810		00MOA10702520	00MOA10702520	ELECT CAP.	100UF 25V CCEA1EH101T
H/P	D801		00MHD20015210	00MHD20015210	DIODE	1SS133T-77 CVD1SS133MT
H/P	D802		00MHD20015210	00MHD20015210	DIODE	1SS133T-77 CVD1SS133MT
H/P	D803		00MHD20015210	00MHD20015210	DIODE	1SS133T-77 CVD1SS133MT
H/P	D804		00MHD20015210	00MHD20015210	DIODE	1SS133T-77 CVD1SS133MT
H/P	J801		nsp	nsp	CORD	SN95/PB5 0.6 C3A206
H/P	J807		nsp	nsp	CORD	SN95/PB5 0.6 C3A206
H/P	J808		nsp	nsp	CORD	SN95/PB5 0.6 C3A206
H/P	J809		nsp	nsp	CORD	SN95/PB5 0.6 C3A206
H/P	J810		nsp	nsp	CORD	SN95/PB5 0.6 C3A206
H/P	J813		nsp	nsp	CORD	SN95/PB5 0.6 C3A206
H/P	J814		nsp	nsp	CORD	SN95/PB5 0.6 C3A206
H/P	J815		nsp	nsp	CORD	SN95/PB5 0.6 C3A206
H/P	J816		nsp	nsp	CORD	SN95/PB5 0.6 C3A206
H/P	J817		nsp	nsp	CORD	SN95/PB5 0.6 C3A206
H/P	J818		nsp	nsp	CORD	SN95/PB5 0.6 C3A206
H/P	J819		nsp	nsp	CORD	SN95/PB5 0.6 C3A206
H/P	J820		nsp	nsp	CORD	SN95/PB5 0.6 C3A206
H/P	J821		nsp	nsp	CORD	SN95/PB5 0.6 C3A206
H/P	J822		nsp	nsp	CORD	SN95/PB5 0.6 C3A206
H/P	J823		nsp	nsp	CORD	SN95/PB5 0.6 C3A206
H/P	J824		nsp	nsp	CORD	SN95/PB5 0.6 C3A206
H/P	PH81		90M-YT004500R	90M-YT004500R	TERMINAL	JACK SILVER PJ-612A-51 CJJ2E026Z
H/P	Q801		00MHT800951B0	00MHT800951B0	TRS.	KTC3203Y HVTKTC3203YT
H/P	Q802		00MHT800951B0	00MHT800951B0	TRS.	KTC3203Y HVTKTC3203YT
H/P	Q803		00MHT600141B0	00MHT600141B0	TRS.	KTA1271Y HVTKTA1271YT
H/P	Q804		00MHT600141B0	00MHT600141B0	TRS.	KTA1271Y HVTKTA1271YT
H/P	Q807		00MHT805501B0	00MHT805501B0	TRS.	KTC2874B HVTKTC2874BT
H/P	Q808		00MHT805501B0	00MHT805501B0	TRS.	KTC2874B HVTKTC2874BT
H/P	Q809		00MHT805501B0	00MHT805501B0	TRS.	KTC2874B HVTKTC2874BT
H/P	Q810		00MHT805501B0	00MHT805501B0	TRS.	KTC2874B HVTKTC2874BT
H/P	R801		00MGD05472160	00MGD05472160	RES.	4.7K OHM 1/6W J CARBON CRD20TJ472T
H/P	R802		00MGD05472160	00MGD05472160	RES.	4.7K OHM 1/6W J CARBON CRD20TJ472T
H/P	R803		00MGD05472160	00MGD05472160	RES.	4.7K OHM 1/6W J CARBON CRD20TJ472T

NOTE : "nsp" PART IS LISTED FOR REFERENCE ONLY, D&M WILL NOT SUPPLY THESE PARTS.

P.W.B. NAME	POS. NO.	VERS. COLOR	PART NO. (FOR EUR)	PART NO. (MZ)	PART NAME	DESCRIPTION	
H/P	R804		00MGD05472160	00MGD05472160	RES.	4.7K OHM 1/6W J CARBON	CRD20TJ472T
H/P	R805		00MGD05152160	00MGD05152160	RES.	1.5K OHM 1/6W J CARBON	CRD20TJ152T
H/P	R806		00MGD05120160	00MGD05120160	RES.	12 OHM 1/6W J CARBON	CRD20TJ120T
H/P	R807		00MGD05330160	00MGD05330160	RES.	33 OHM 1/6W J CARBON	CRD20TJ330T
H/P	R808		00MGD05120160	00MGD05120160	RES.	12 OHM 1/6W J CARBON	CRD20TJ120T
H/P	R809		00MGD05152160	00MGD05152160	RES.	1.5K OHM 1/6W J CARBON	CRD20TJ152T
H/P	R810		00MGD05330160	00MGD05330160	RES.	33 OHM 1/6W J CARBON	CRD20TJ330T
H/P	R811		00MGD05152160	00MGD05152160	RES.	1.5K OHM 1/6W J CARBON	CRD20TJ152T
H/P	R812		00MGD05120160	00MGD05120160	RES.	12 OHM 1/6W J CARBON	CRD20TJ120T
H/P	R813		00MGD05330160	00MGD05330160	RES.	33 OHM 1/6W J CARBON	CRD20TJ330T
H/P	R814		00MGD05120160	00MGD05120160	RES.	12 OHM 1/6W J CARBON	CRD20TJ120T
H/P	R815		00MGD05152160	00MGD05152160	RES.	1.5K OHM 1/6W J CARBON	CRD20TJ152T
H/P	R816		00MGD05330160	00MGD05330160	RES.	33 OHM 1/6W J CARBON	CRD20TJ330T
H/P	R817		00MGD05750160	00MGD05750160	RES.	75 OHM 1/6W J CARBON	CRD20TJ750T
H/P	R818		00MGD05103160	00MGD05103160	RES.	10K OHM 1/6W J CARBON	CRD20TJ103T
H/P	R819		00MGD05103160	00MGD05103160	RES.	10K OHM 1/6W J CARBON	CRD20TJ103T
H/P	R820		00MGD05750160	00MGD05750160	RES.	75 OHM 1/6W J CARBON	CRD20TJ750T
H/P	R821		00MGD05472160	00MGD05472160	RES.	4.7K OHM 1/6W J CARBON	CRD20TJ472T
H/P	R822		00MGD05472160	00MGD05472160	RES.	4.7K OHM 1/6W J CARBON	CRD20TJ472T
H/P	R823		00MGD05750160	00MGD05750160	RES.	75 OHM 1/6W J CARBON	CRD20TJ750T
H/P	R824		00MGD05750160	00MGD05750160	RES.	75 OHM 1/6W J CARBON	CRD20TJ750T
H/P	R825		00MGD05472160	00MGD05472160	RES.	4.7K OHM 1/6W J CARBON	CRD20TJ472T
H/P	R826		00MGD05472160	00MGD05472160	RES.	4.7K OHM 1/6W J CARBON	CRD20TJ472T
H/P	R827		00MGD05010160	00MGD05010160	RES.	1 OHM 1/6W J CARBON	CRD20TJ1R0T
H/P	R828		00MGD05010160	00MGD05010160	RES.	1 OHM 1/6W J CARBON	CRD20TJ1R0T
H/P	R829		00MGD05104160	00MGD05104160	RES.	100K OHM 1/6W J CARBON	CRD20TJ104T
H/P	R830		00MGD05104160	00MGD05104160	RES.	100K OHM 1/6W J CARBON	CRD20TJ104T
H/P	VR81		943671002420S	943671002420S	VAR. RES.	10KA A CURVE	CVV3J02A103Z
					MAIN PWB(CUP12190) POWER PWB(CUP12192-1)		
MAIN	BK21		nsp	nsp	BRACKET	PCB,AUDIO+POWERCD6003(330*247,FR1/1)	CMD1A569
MAIN	BK31		nsp	nsp	HEATSINK	HEAT SINK	CMY1A267
MAIN	C101		00MOA47602520	00MOA47602520	ELECT CAP.	47UF 25V	CCEA1EH470T
MAIN	C102		00MDK96104300	00MDK96104300	CER. CAP.	0.1UF 50V K	CCUS1H104KC
MAIN	C103		00MDK96104300	00MDK96104300	CER. CAP.	0.1UF 50V K	CCUS1H104KC
MAIN	C104		00MDK96104300	00MDK96104300	CER. CAP.	0.1UF 50V K	CCUS1H104KC
MAIN	C105		00MDK96104300	00MDK96104300	CER. CAP.	0.1UF 50V K	CCUS1H104KC
MAIN	C106		00MOA47602520	00MOA47602520	ELECT CAP.	47UF 25V	CCEA1EH470T
MAIN	C107		00MDK96104300	00MDK96104300	CER. CAP.	0.1UF 50V K	CCUS1H104KC
MAIN	C108		00MDK96104300	00MDK96104300	CER. CAP.	0.1UF 50V K	CCUS1H104KC
MAIN	C109		00MOA47602520	00MOA47602520	ELECT CAP.	47UF 25V	CCEA1EH470T
MAIN	C110		00MOA47602520	00MOA47602520	ELECT CAP.	47UF 25V	CCEA1EH470T
MAIN	C111		00MDK96104300	00MDK96104300	CER. CAP.	0.1UF 50V K	CCUS1H104KC
MAIN	C112		00MDK96104300	00MDK96104300	CER. CAP.	0.1UF 50V K	CCUS1H104KC
MAIN	C113		00MDK96104300	00MDK96104300	CER. CAP.	0.1UF 50V K	CCUS1H104KC
MAIN	C114		00MDK96104300	00MDK96104300	CER. CAP.	0.1UF 50V K	CCUS1H104KC
MAIN	C115		00MOA47602520	00MOA47602520	ELECT CAP.	47UF 25V	CCEA1EH470T
MAIN	C116		00MDD91090300	00MDD91090300	CER. CAP.	9PF 50V DA	CCUS1H090DA
MAIN	C117		00MDD91090300	00MDD91090300	CER. CAP.	9PF 50V DA	CCUS1H090DA
MAIN	C118		00MDK96104300	00MDK96104300	CER. CAP.	0.1UF 50V K	CCUS1H104KC
MAIN	C119		00MOA47602520	00MOA47602520	ELECT CAP.	47UF 25V	CCEA1EH470T
MAIN	C120		00MDK96104300	00MDK96104300	CER. CAP.	0.1UF 50V K	CCUS1H104KC
MAIN	C161		00MOA47701620	00MOA47701620	ELECT CAP.	470UF 16V ZF	CCEA1CH471T
MAIN	C162		00MDK96104300	00MDK96104300	CER. CAP.	0.1UF 50V K	CCUS1H104KC
MAIN	C163		00MOA10701620	00MOA10701620	ELECT CAP.	100UF 16V	CCEA1CH101T
MAIN	C181		00MOA10701620	00MOA10701620	ELECT CAP.	100UF 16V	CCEA1CH101T
MAIN	C182		00MDK96104300	00MDK96104300	CER. CAP.	0.1UF 50V K	CCUS1H104KC
MAIN	C183		00MOA47602520	00MOA47602520	ELECT CAP.	47UF 25V	CCEA1EH470T
MAIN	C184		00MDK96104300	00MDK96104300	CER. CAP.	0.1UF 50V K	CCUS1H104KC
MAIN	C201		00MDD95220300	00MDD95220300	CER. CAP.	22PF 50V JA	CCUS1H220JA
MAIN	C202		00MDD95220300	00MDD95220300	CER. CAP.	22PF 50V JA	CCUS1H220JA
MAIN	C203		00MDK96104300	00MDK96104300	CER. CAP.	0.1UF 50V K	CCUS1H104KC
MAIN	C204		00MDK96104300	00MDK96104300	CER. CAP.	0.1UF 50V K	CCUS1H104KC
MAIN	C205		00MDK96104300	00MDK96104300	CER. CAP.	0.1UF 50V K	CCUS1H104KC
MAIN	C206		90M-DK900090R	90M-DK900090R	CER. CAP.	1UF 10V KC	CCUS1A105KC
MAIN	C207		00MDK96104300	00MDK96104300	CER. CAP.	0.1UF 50V K	CCUS1H104KC
MAIN	C208		00MOA10701620	00MOA10701620	ELECT CAP.	100UF 16V	CCEA1CH101T
MAIN	C209		00MDK96104300	00MDK96104300	CER. CAP.	0.1UF 50V K	CCUS1H104KC
MAIN	C210		00MOA47602520	00MOA47602520	ELECT CAP.	47UF 25V	CCEA1EH470T
MAIN	C211		00MDK96104300	00MDK96104300	CER. CAP.	0.1UF 50V K	CCUS1H104KC
MAIN	C212		00MOA47602520	00MOA47602520	ELECT CAP.	47UF 25V	CCEA1EH470T
MAIN	C213		00MDK96104300	00MDK96104300	CER. CAP.	0.1UF 50V K	CCUS1H104KC
MAIN	C214		00MDD95220300	00MDD95220300	CER. CAP.	22PF 50V JA	CCUS1H220JA
MAIN	C215		00MDD95220300	00MDD95220300	CER. CAP.	22PF 50V JA	CCUS1H220JA
MAIN	C216		00MDK96104300	00MDK96104300	CER. CAP.	0.1UF 50V K	CCUS1H104KC
MAIN	C217		00MDK96104300	00MDK96104300	CER. CAP.	0.1UF 50V K	CCUS1H104KC

NOTE : "nsp" PART IS LISTED FOR REFERENCE ONLY, D&M WILL NOT SUPPLY THESE PARTS.

P.W.B. NAME	POS. NO.	VERS. COLOR	PART NO. (FOR EUR)	PART NO. (MZ)	PART NAME	DESCRIPTION
MAIN	C218		00MDK96104300	00MDK96104300	CER. CAP.	0.1UF 50V K CCUS1H104KC
MAIN	C219		00MOA22701620	00MOA22701620	ELECT CAP.	220UF 16V CCEA1CH221T
MAIN	C220		00MDK96103300	00MDK96103300	CER. CAP.	0.01UF 50V KC CCUS1H103KC
MAIN	C221		00MOA10701620	00MOA10701620	ELECT CAP.	100UF 16V CCEA1CH101T
MAIN	C251		00MOA10701620	00MOA10701620	ELECT CAP.	100UF 16V CCEA1CH101T
MAIN	C252		00MDK96104300	00MDK96104300	CER. CAP.	0.1UF 50V K CCUS1H104KC
MAIN	C253		00MOA47602520	00MOA47602520	ELECT CAP.	47UF 25V CCEA1EH470T
MAIN	C254		00MDK96104300	00MDK96104300	CER. CAP.	0.1UF 50V K CCUS1H104KC
MAIN	C258		00MDK96104300	00MDK96104300	CER. CAP.	0.1UF 50V K CCUS1H104KC
MAIN	C259		00MDK96104300	00MDK96104300	CER. CAP.	0.1UF 50V K CCUS1H104KC
MAIN	C260		00MDD95180300	00MDD95180300	CER. CAP.	18PF 50V JA CCUS1H180JA
MAIN	C261		00MDD9515030R	00MDD9515030R	CER. CAP.	15PF 50V JA CCUS1H150JA
MAIN	C264		00MDK96104300	00MDK96104300	CER. CAP.	0.1UF 50V K CCUS1H104KC
MAIN	C301		00MDK96104300	00MDK96104300	CER. CAP.	0.1UF 50V K CCUS1H104KC
MAIN	C306		00MDK96104300	00MDK96104300	CER. CAP.	0.1UF 50V K CCUS1H104KC
MAIN	C310		00MDD95470300	00MDD95470300	CER. CAP.	47PF 50V JA CCUS1H470JA
MAIN	C311		00MDK96333300	00MDK96333300	CER. CAP.	0.033UF 50V K CCUS1H333KC
MAIN	C312		00MDK96104300	00MDK96104300	CER. CAP.	0.1UF 50V K CCUS1H104KC
MAIN	C313		00MOA47602520	00MOA47602520	ELECT CAP.	47UF 25V CCEA1EH470T
MAIN	C314		00MDK96153300	00MDK96153300	CER. CAP.	0.015UF 50V CCUS1H153KC
MAIN	C315		00MDK96103300	00MDK96103300	CER. CAP.	0.01UF 50V KC CCUS1H103KC
MAIN	C316		00MDK96103300	00MDK96103300	CER. CAP.	0.01UF 50V KC CCUS1H103KC
MAIN	C317		00MDK96472300	00MDK96472300	CER. CAP.	4700PF 50V KC CCUS1H472KC
MAIN	C318		00MDK96104300	00MDK96104300	CER. CAP.	0.1UF 50V K CCUS1H104KC
MAIN	C319		00MDK96103300	00MDK96103300	CER. CAP.	0.01UF 50V KC CCUS1H103KC
MAIN	C320		00MDK96104300	00MDK96104300	CER. CAP.	0.1UF 50V K CCUS1H104KC
MAIN	C321		00MDK96153300	00MDK96153300	CER. CAP.	0.015UF 50V CCUS1H153KC
MAIN	C322		00MDK96104300	00MDK96104300	CER. CAP.	0.1UF 50V K CCUS1H104KC
MAIN	C323		00MDD95680300	00MDD95680300	CER. CAP.	68PF 50V JA CCUS1H680JA
MAIN	C324		00MDK96104300	00MDK96104300	CER. CAP.	0.1UF 50V K CCUS1H104KC
MAIN	C325		00MOA47701620	00MOA47701620	ELECT CAP.	470UF 16V ZF CCEA1CH471T
MAIN	C326		00MOA10701620	00MOA10701620	ELECT CAP.	100UF 16V CCEA1CH101T
MAIN	C327		00MOA10701620	00MOA10701620	ELECT CAP.	100UF 16V CCEA1CH101T
MAIN	C328		00MOA10701620	00MOA10701620	ELECT CAP.	100UF 16V CCEA1CH101T
MAIN	C329		00MDK96102300	00MDK96102300	CER. CAP.	1000PF 50V KC CCUS1H102KC
MAIN	C330		00MDK96104300	00MDK96104300	CER. CAP.	0.1UF 50V K CCUS1H104KC
MAIN	C331		00MDK96333300	00MDK96333300	CER. CAP.	0.033UF 50V K CCUS1H333KC
MAIN	C332		00MDK96333300	00MDK96333300	CER. CAP.	0.033UF 50V K CCUS1H333KC
MAIN	C333		00MDK96104300	00MDK96104300	CER. CAP.	0.1UF 50V K CCUS1H104KC
MAIN	C334		00MDD95471300	00MDD95471300	CER. CAP.	470PF 50V JA CCUS1H471JA
MAIN	C335		00MDD95471300	00MDD95471300	CER. CAP.	470PF 50V JA CCUS1H471JA
MAIN	C336		90M-OA000630R	90M-OA000630R	ELECT CAP.	KZH 6.3V/1000UF CCEA0JKZH102KS
MAIN	C337		00MDK96103300	00MDK96103300	CER. CAP.	0.01UF 50V KC CCUS1H103KC
MAIN	C338		00MDK96473300	00MDK96473300	CER. CAP.	0.043UF 50V KC CCUS1H473KC
MAIN	C339		00MDK96473300	00MDK96473300	CER. CAP.	0.043UF 50V KC CCUS1H473KC
MAIN	C340		00MDK96104300	00MDK96104300	CER. CAP.	0.1UF 50V K CCUS1H104KC
MAIN	C341		00MOA22701620	00MOA22701620	ELECT CAP.	220UF 16V CCEA1CH221T
MAIN	C342		00MDK96222300	00MDK96222300	CER. CAP.	2200PF 50V KC CCUS1H222KC
MAIN	C343		00MDK96104300	00MDK96104300	CER. CAP.	0.1UF 50V K CCUS1H104KC
MAIN	C344		00MDK96104300	00MDK96104300	CER. CAP.	0.1UF 50V K CCUS1H104KC
MAIN	C345		00MDK96104300	00MDK96104300	CER. CAP.	0.1UF 50V K CCUS1H104KC
MAIN	C346		00MOA47602520	00MOA47602520	ELECT CAP.	47UF 25V CCEA1EH470T
MAIN	C347		00MDK96104300	00MDK96104300	CER. CAP.	0.1UF 50V K CCUS1H104KC
MAIN	C348		00MDK96104300	00MDK96104300	CER. CAP.	0.1UF 50V K CCUS1H104KC
MAIN	C349		00MOA10701620	00MOA10701620	ELECT CAP.	100UF 16V CCEA1CH101T
MAIN	C350		00MDK96104300	00MDK96104300	CER. CAP.	0.1UF 50V K CCUS1H104KC
MAIN	C351		00MDK96104300	00MDK96104300	CER. CAP.	0.1UF 50V K CCUS1H104KC
MAIN	C352		00MDK96104300	00MDK96104300	CER. CAP.	0.1UF 50V K CCUS1H104KC
MAIN	C353		00MDK96104300	00MDK96104300	CER. CAP.	0.1UF 50V K CCUS1H104KC
MAIN	C354		00MDK96104300	00MDK96104300	CER. CAP.	0.1UF 50V K CCUS1H104KC
MAIN	C360		00MOA47602520	00MOA47602520	ELECT CAP.	47UF 25V CCEA1EH470T
MAIN	C361		00MDK96104300	00MDK96104300	CER. CAP.	0.1UF 50V K CCUS1H104KC
MAIN	C362		00MOA10701620	00MOA10701620	ELECT CAP.	100UF 16V CCEA1CH101T
MAIN	C363		00MDK96104300	00MDK96104300	CER. CAP.	0.1UF 50V K CCUS1H104KC
MAIN	C364		00MOA47602520	00MOA47602520	ELECT CAP.	47UF 25V CCEA1EH470T
MAIN	C365		00MDK96104300	00MDK96104300	CER. CAP.	0.1UF 50V K CCUS1H104KC
MAIN	C366		00MDK96104300	00MDK96104300	CER. CAP.	0.1UF 50V K CCUS1H104KC
MAIN	C401		00MOA22701620	00MOA22701620	ELECT CAP.	220UF 16V CCEA1CH221T
MAIN	C402		00MDK96104300	00MDK96104300	CER. CAP.	0.1UF 50V K CCUS1H104KC
MAIN	C403		00MDD95120300	00MDD95120300	CER. CAP.	12PF 50V JA CCUS1H120JA
MAIN	C404		00MDK96104300	00MDK96104300	CER. CAP.	0.1UF 50V K CCUS1H104KC
MAIN	C405		00MOA22701620	00MOA22701620	ELECT CAP.	220UF 16V CCEA1CH221T
MAIN	C406		00MDD95101300	00MDD95101300	CER. CAP.	100PF 50V JA CCUS1H101JA
MAIN	C408		90M-DK900090R	90M-DK900090R	CER. CAP.	1UF 10V KC CCUS1A105KC
MAIN	C411		00MDK96104300	00MDK96104300	CER. CAP.	0.1UF 50V K CCUS1H104KC
MAIN	C412		00MDK96104300	00MDK96104300	CER. CAP.	0.1UF 50V K CCUS1H104KC

NOTE : *nsp* PART IS LISTED FOR REFERENCE ONLY, D&M WILL NOT SUPPLY THESE PARTS.

P.W.B. NAME	POS. NO.	VERS. COLOR	PART NO. (FOR EUR)	PART NO. (MZ)	PART NAME	DESCRIPTION
MAIN	C431		00MOA22802520	00MOA22802520	ELECT CAP.	2200UF 25V CCEA1EH222E
MAIN	C433		00MOA22505020	00MOA22505020	ELECT CAP.	2.2UF 50V CCEA1HH2R2T
MAIN	C465		00MDK96104300	00MDK96104300	CER. CAP.	0.1UF 50V K CCUS1H104KC
MAIN	C466		00MOA10701620	00MOA10701620	ELECT CAP.	100UF 16V CCEA1CH101T
MAIN	CN21		nsp	nsp	CONN.	19P WAFER FFC FCZ100E-19SSK CJP19GA117ZY
MAIN	CN22		nsp	nsp	CONN.	7P WAFER CARD CABLE CJP07GB113ZY
MAIN	CN23		nsp	nsp	CONN.	5P STRAIGHT 20017WS-05 CJP05GA19ZY
MAIN	CN31		nsp	nsp	CONN.	5P STRAIGHT 20017WS-05 CJP05GA19ZY
MAIN	CN32		nsp	nsp	CONN.	6P STRAIGHT 20017WS-06 CJP06GA19ZY
MAIN	CN33		nsp	nsp	CONN.	16P WAFER FFC FCZ100E-16SSK CJP16GA117ZY
MAIN	CN42		nsp	nsp	#N/A	LOCKINGTYPE,STRAIGHTWAFER, 2MM CJP13GI236ZW
MAIN	CN43		nsp	nsp	WAFER	LOCKINGTYPE,STRAIGHTWAFER, 2.5MM CJP05GI237ZW
MAIN	CN44		nsp	nsp	WAFER	LOCKINGTYPE,STRAIGHTWAFER, 2.5MM CJP05GI237ZW
MAIN	CN45		nsp	nsp	WAFER	LOCKINGTYPE,STRAIGHTWAFER, 2MM CJP13GI236ZW
MAIN	D201		00MHZ21303210	00MHZ21303210	DIODE	1SS355 CVD1SS355T
MAIN	D202		00MHZ21303210	00MHZ21303210	DIODE	1SS355 CVD1SS355T
MAIN	D203		00MHZ21303210	00MHZ21303210	DIODE	1SS355 CVD1SS355T
MAIN	D204		00MHZ21303210	00MHZ21303210	DIODE	1SS355 CVD1SS355T
MAIN	D205		00MHZ21303210	00MHZ21303210	DIODE	1SS355 CVD1SS355T
MAIN	D206		00MHZ21303210	00MHZ21303210	DIODE	1SS355 CVD1SS355T
MAIN	D207		00MHZ21303210	00MHZ21303210	DIODE	1SS355 CVD1SS355T
MAIN	D301		00MHZ21303210	00MHZ21303210	DIODE	1SS355 CVD1SS355T
MAIN	D401		00MHZ21303210	00MHZ21303210	DIODE	1SS355 CVD1SS355T
MAIN	D431		90M-HD302440R	90M-HD302440R	ZENER DIODE	ZJ4.7B 1/2W CVDZJ4.7BT
MAIN	D432		90M-HD201750R	90M-HD201750R	DIODE	1N4003 CVD1N4003SRT
MAIN	D434		90M-HD302460R	90M-HD302460R	ZENER DIODE	ZJ5.6B 1/2W CVDZJ5.6BT
MAIN	D435		00MHZ21303210	00MHZ21303210	DIODE	1SS355 CVD1SS355T
MAIN	IC11		245710006603S	245710006603S	IC	UPD63901GJ(A)-301-8EN-A CVI245710006603SM
MAIN	IC12		90M-HC109290R	90M-HC109290R	IC	TC74VHC157FT HVITC74VHC157FT
MAIN	IC18		90M-HC900150R	90M-HC900150R	IC	KIA1117S/F33 REGULATOR(SOT-223) CVIKIA1117S33
MAIN	IC21		943243007230M	943243007230M	U-PRO	I.C,FLASHU-COM CD6003 CVIT5CC1 CVIT5CC1
MAIN	IC22		943236000650S	943236000650S	IC	AT24C04BN-SH-B CVIAT24C04BNSHB
MAIN	IC23		943239007240M	943239007240M	IC	I.C,RESET2.8V(50ms,C-MOS,SOT23-5P) CVIS80128ALMCJANT2
MAIN	IC26		943239007250M	943239007250M	IC	I.C,CURRENTLIMITER(500MA,SOT-23-5) CVIRT9702PB
MAIN	IC27		943239007260M	943239007260M	IC	I.C,CPCHIP(MF134IS2161,20P,FROMMARANTZ) CVI236710022502S_M
MAIN	IC29		943231002450S	943231002450S	IC	KIA1117S18-RTK/ CVIKIA1117S18
MAIN	IC30		943235002460S	943235002460S	IC	CDCE913PWR CVICDCE913PWR
MAIN	IC31		943239007270M	943239007270M	IC	I.C,CDDSP(VER-007,LQFP-100P) CVITC94A70FG-007
MAIN	IC32		90M-HC109470R	90M-HC109470R	IC	TA2125AFG HVITA2125AFG
MAIN	IC36		90M-HC900150R	90M-HC900150R	IC	KIA1117S/F33 REGULATOR(SOT-223) CVIKIA1117S33
MAIN	IC37		90M-HC900160R	90M-HC900160R	IC	LM1117S15 REGULATOR(SOT-223) CVIKIA1117S15
MAIN	IC61		90M-HC900150R	90M-HC900150R	IC	KIA1117S/F33 REGULATOR(SOT-223) CVIKIA1117S33
MAIN	JK41		90M-YT005310R	90M-YT005310R	OPT. CONN.	TOTX177L HJSTOTX177L
MAIN	JK42		943646000840S	943646000840S	TERMINAL	CINCH 1P JACK BLACK CJJ4M056W
MAIN	JK43		90M-YT003120R	90M-YT003120R	TERMINAL	CINCH 2P JE0200598N CJJ4N036Z
MAIN	L161		90M-FN000260R	90M-FN000260R	EMI FILTER	HU-1H3216-121 HLZ91002Z
MAIN	L162		90M-FN000260R	90M-FN000260R	EMI FILTER	HU-1H3216-121 HLZ91002Z
MAIN	L181		90M-FN000260R	90M-FN000260R	EMI FILTER	HU-1H3216-121 HLZ91002Z
MAIN	L201		90M-FC900380R	90M-FC900380R	FERRITE CORE	FB 2012(0805)600E 1.5A POWER CLZ9R001Z
MAIN	L251		90M-FN000260R	90M-FN000260R	EMI FILTER	HU-1H3216-121 HLZ91002Z
MAIN	L252		90M-FN000260R	90M-FN000260R	EMI FILTER	HU-1H3216-121 HLZ91002Z
MAIN	L301		90M-FN000260R	90M-FN000260R	EMI FILTER	HU-1H3216-121 HLZ91002Z
MAIN	L302		90M-FN000260R	90M-FN000260R	EMI FILTER	HU-1H3216-121 HLZ91002Z
MAIN	L303		nsp	nsp	CHIP INDUCT.	FI-C3216-103KJT HLQ09E100KRZ
MAIN	L401		90M-FN000260R	90M-FN000260R	EMI FILTER	HU-1H3216-121 HLZ91002Z
MAIN	Q202		90M-HX600010R	90M-HX600010R	CHIP TRS.	KRA102S HVTKRA102S
MAIN	Q203		90M-HX600010R	90M-HX600010R	CHIP TRS.	KRA102S HVTKRA102S
MAIN	Q301		90M-HX600020R	90M-HX600020R	CHIP TRS.	KTA1504S Y RTK HVTKTA1504SYRTK
MAIN	Q302		90M-HX800090R	90M-HX800090R	CHIP TRS.	KRC111S HVTKRC111S
MAIN	Q303		90M-HX800090R	90M-HX800090R	CHIP TRS.	KRC111S HVTKRC111S
MAIN	Q401		90M-HX800100R	90M-HX800100R	CHIP TRS.	KTC3875S Y RTK HVTKTC3875SYRTK
MAIN	Q402		90M-HX800100R	90M-HX800100R	CHIP TRS.	KTC3875S Y RTK HVTKTC3875SYRTK
MAIN	Q431		00MHT600111B0	00MHT600111B0	TRS.	KTA1267Y HVTKTA1267YT
MAIN	Q432		90M-HX800090R	90M-HX800090R	CHIP TRS.	KRC111S HVTKRC111S
MAIN	Q433		90M-HX800090R	90M-HX800090R	CHIP TRS.	KRC111S HVTKRC111S
MAIN	Q434		00MHT30001000	00MHT30001000	TRS.	KTC3199Y HVTKTC3199YT
MAIN	R101		00MNN05000610	00MNN05000610	CHIP RES.	0 OHM 1/10W J CRJ10DJ0R0T
MAIN	R102		00MNN05000610	00MNN05000610	CHIP RES.	0 OHM 1/10W J CRJ10DJ0R0T
MAIN	R103		00MNN05000610	00MNN05000610	CHIP RES.	0 OHM 1/10W J CRJ10DJ0R0T
MAIN	R104		00MNN05220610	00MNN05220610	CHIP RES.	22 OHM 1/10W J CRJ10DJ220T
MAIN	R105		00MNN05103610	00MNN05103610	CHIP RES.	10K OHM 1/10W J CRJ10DJ103T
MAIN	R106		00MNN05103610	00MNN05103610	CHIP RES.	10K OHM 1/10W J CRJ10DJ103T
MAIN	R108		00MNN05000610	00MNN05000610	CHIP RES.	0 OHM 1/10W J CRJ10DJ0R0T
MAIN	R109		00MNN05000610	00MNN05000610	CHIP RES.	0 OHM 1/10W J CRJ10DJ0R0T
MAIN	R110		00MNN05000610	00MNN05000610	CHIP RES.	0 OHM 1/10W J CRJ10DJ0R0T
MAIN	R111		00MNN05000610	00MNN05000610	CHIP RES.	0 OHM 1/10W J CRJ10DJ0R0T

NOTE : "nsp" PART IS LISTED FOR REFERENCE ONLY, D&M WILL NOT SUPPLY THESE PARTS.

P.W.B. NAME	POS. NO.	VERS. COLOR	PART NO. (FOR EUR)	PART NO. (MZ)	PART NAME	DESCRIPTION
MAIN	R112		00MNN05561610	00MNN05561610	CHIP RES.	560 OHM 1/10W J CRJ10DJ561T
MAIN	R113		00MNN05000610	00MNN05000610	CHIP RES.	0 OHM 1/10W J CRJ10DJ0R0T
MAIN	R114		00MNN05103610	00MNN05103610	CHIP RES.	10K OHM 1/10W J CRJ10DJ103T
MAIN	R115		00MNN05103610	00MNN05103610	CHIP RES.	10K OHM 1/10W J CRJ10DJ103T
MAIN	R116		00MNN05220610	00MNN05220610	CHIP RES.	22 OHM 1/10W J CRJ10DJ220T
MAIN	R117		00MNN05220610	00MNN05220610	CHIP RES.	22 OHM 1/10W J CRJ10DJ220T
MAIN	R118		00MNN05220610	00MNN05220610	CHIP RES.	22 OHM 1/10W J CRJ10DJ220T
MAIN	R119		00MNN05220610	00MNN05220610	CHIP RES.	22 OHM 1/10W J CRJ10DJ220T
MAIN	R120		00MNN05220610	00MNN05220610	CHIP RES.	22 OHM 1/10W J CRJ10DJ220T
MAIN	R121		00MNN05220610	00MNN05220610	CHIP RES.	22 OHM 1/10W J CRJ10DJ220T
MAIN	R122		00MNN05220610	00MNN05220610	CHIP RES.	22 OHM 1/10W J CRJ10DJ220T
MAIN	R123		00MNN05220610	00MNN05220610	CHIP RES.	22 OHM 1/10W J CRJ10DJ220T
MAIN	R124		00MNN05220610	00MNN05220610	CHIP RES.	22 OHM 1/10W J CRJ10DJ220T
MAIN	R125		00MNN05103610	00MNN05103610	CHIP RES.	10K OHM 1/10W J CRJ10DJ103T
MAIN	R201		00MNN05103610	00MNN05103610	CHIP RES.	10K OHM 1/10W J CRJ10DJ103T
MAIN	R202		00MNN05000610	00MNN05000610	CHIP RES.	0 OHM 1/10W J CRJ10DJ0R0T
MAIN	R204		00MNN05105610	00MNN05105610	CHIP RES.	1M OHM 1/10W J CRJ10DJ105T
MAIN	R205		00MNN05000610	00MNN05000610	CHIP RES.	0 OHM 1/10W J CRJ10DJ0R0T
MAIN	R206		00MNN05000610	00MNN05000610	CHIP RES.	0 OHM 1/10W J CRJ10DJ0R0T
MAIN	R209		00MNN05101610	00MNN05101610	CHIP RES.	100 OHM 1/10W J CRJ10DJ101T
MAIN	R210		00MNN05000610	00MNN05000610	CHIP RES.	0 OHM 1/10W J CRJ10DJ0R0T
MAIN	R211		00MNN05000610	00MNN05000610	CHIP RES.	0 OHM 1/10W J CRJ10DJ0R0T
MAIN	R212		00MNN05472610	00MNN05472610	CHIP RES.	4.7K OHM 1/10W J CRJ10DJ472T
MAIN	R213		00MNN05472610	00MNN05472610	CHIP RES.	4.7K OHM 1/10W J CRJ10DJ472T
MAIN	R214		00MNN05103610	00MNN05103610	CHIP RES.	10K OHM 1/10W J CRJ10DJ103T
MAIN	R215		00MNN05103610	00MNN05103610	CHIP RES.	10K OHM 1/10W J CRJ10DJ103T
MAIN	R216		00MNN05103610	00MNN05103610	CHIP RES.	10K OHM 1/10W J CRJ10DJ103T
MAIN	R217		00MNN05102610	00MNN05102610	CHIP RES.	1K OHM 1/10W J CRJ10DJ102T
MAIN	R218		00MNN05220610	00MNN05220610	CHIP RES.	22 OHM 1/10W J CRJ10DJ220T
MAIN	R219		00MNN05103610	00MNN05103610	CHIP RES.	10K OHM 1/10W J CRJ10DJ103T
MAIN	R220		943129007280M	943129007280M	RES	RES, CHIP CRJ10DJ240T
MAIN	R221		943129007280M	943129007280M	RES	RES, CHIP CRJ10DJ240T
MAIN	R222		00MNN05153610	00MNN05153610	CHIP RES.	15K OHM 1/10W J CRJ10DJ153T
MAIN	R223		00MNN05153610	00MNN05153610	CHIP RES.	15K OHM 1/10W J CRJ10DJ153T
MAIN	R224		00MNN05103610	00MNN05103610	CHIP RES.	10K OHM 1/10W J CRJ10DJ103T
MAIN	R225		00MNN05103610	00MNN05103610	CHIP RES.	10K OHM 1/10W J CRJ10DJ103T
MAIN	R226		00MNN05220610	00MNN05220610	CHIP RES.	22 OHM 1/10W J CRJ10DJ220T
MAIN	R227		00MNN05220610	00MNN05220610	CHIP RES.	22 OHM 1/10W J CRJ10DJ220T
MAIN	R228		00MNN05220610	00MNN05220610	CHIP RES.	22 OHM 1/10W J CRJ10DJ220T
MAIN	R229		00MNN05220610	00MNN05220610	CHIP RES.	22 OHM 1/10W J CRJ10DJ220T
MAIN	R230		00MNN05220610	00MNN05220610	CHIP RES.	22 OHM 1/10W J CRJ10DJ220T
MAIN	R231		00MNN05220610	00MNN05220610	CHIP RES.	22 OHM 1/10W J CRJ10DJ220T
MAIN	R232		00MNN05221610	00MNN05221610	CHIP RES.	220 OHM 1/10W J CRJ10DJ221T
MAIN	R235		00MNN05000610	00MNN05000610	CHIP RES.	0 OHM 1/10W J CRJ10DJ0R0T
MAIN	R236		00MNN05000610	00MNN05000610	CHIP RES.	0 OHM 1/10W J CRJ10DJ0R0T
MAIN	R237		00MNN05000610	00MNN05000610	CHIP RES.	0 OHM 1/10W J CRJ10DJ0R0T
MAIN	R238		00MNN05103610	00MNN05103610	CHIP RES.	10K OHM 1/10W J CRJ10DJ103T
MAIN	R240		00MNN05223610	00MNN05223610	CHIP RES.	22K OHM 1/10W J CRJ10DJ223T
MAIN	R241		00MNN05223610	00MNN05223610	CHIP RES.	22K OHM 1/10W J CRJ10DJ223T
MAIN	R242		00MNN05223610	00MNN05223610	CHIP RES.	22K OHM 1/10W J CRJ10DJ223T
MAIN	R243		00MNN05223610	00MNN05223610	CHIP RES.	22K OHM 1/10W J CRJ10DJ223T
MAIN	R244		00MNN05223610	00MNN05223610	CHIP RES.	22K OHM 1/10W J CRJ10DJ223T
MAIN	R245		00MNN05000610	00MNN05000610	CHIP RES.	0 OHM 1/10W J CRJ10DJ0R0T
MAIN	R255		00MNN05220610	00MNN05220610	CHIP RES.	22 OHM 1/10W J CRJ10DJ220T
MAIN	R256		00MNN05100610	00MNN05100610	CHIP RES.	10 OHM 1/10W J CRJ10DJ100T
MAIN	R257		00MNN05000610	00MNN05000610	CHIP RES.	0 OHM 1/10W J CRJ10DJ0R0T
MAIN	R258		00MNN05000610	00MNN05000610	CHIP RES.	0 OHM 1/10W J CRJ10DJ0R0T
MAIN	R262		00MNN05271610	00MNN05271610	CHIP RES.	270 OHM +-5% 1/16W CRJ10DJ271T
MAIN	R266		00MNN05103610	00MNN05103610	CHIP RES.	10K OHM 1/10W J CRJ10DJ103T
MAIN	R267		00MNN05103610	00MNN05103610	CHIP RES.	10K OHM 1/10W J CRJ10DJ103T
MAIN	R268		00MNN05000610	00MNN05000610	CHIP RES.	0 OHM 1/10W J CRJ10DJ0R0T
MAIN	R269		00MNN05000610	00MNN05000610	CHIP RES.	0 OHM 1/10W J CRJ10DJ0R0T
MAIN	R270		00MNN05100610	00MNN05100610	CHIP RES.	10 OHM 1/10W J CRJ10DJ100T
MAIN	R306		00MNN05104610	00MNN05104610	CHIP RES.	100K OHM 1/10W J CRJ10DJ104T
MAIN	R309		00MNN05104610	00MNN05104610	CHIP RES.	100K OHM 1/10W J CRJ10DJ104T
MAIN	R310		00MNN05103610	00MNN05103610	CHIP RES.	10K OHM 1/10W J CRJ10DJ103T
MAIN	R311		00MNN05000610	00MNN05000610	CHIP RES.	0 OHM 1/10W J CRJ10DJ0R0T
MAIN	R312		00MNN05000610	00MNN05000610	CHIP RES.	0 OHM 1/10W J CRJ10DJ0R0T
MAIN	R313		00MNN05000610	00MNN05000610	CHIP RES.	0 OHM 1/10W J CRJ10DJ0R0T
MAIN	R314		00MNN05562610	00MNN05562610	CHIP RES.	5.6K OHM 1/10W J CRJ10DJ562T
MAIN	R315		00MNN05473610	00MNN05473610	CHIP RES.	47K OHM 1/10W J CRJ10DJ473T
MAIN	R316		00MNN05334610	00MNN05334610	CHIP RES.	330K OHM 1/10W J CRJ10DJ334T
MAIN	R317		00MNN05154610	00MNN05154610	CHIP RES.	150K OHM 1/10W J CRJ10DJ154T
MAIN	R318		00MNN05153610	00MNN05153610	CHIP RES.	15K OHM 1/10W J CRJ10DJ153T
MAIN	R319		00MNN05223610	00MNN05223610	CHIP RES.	22K OHM 1/10W J CRJ10DJ223T
MAIN	R320		00MNN05000610	00MNN05000610	CHIP RES.	0 OHM 1/10W J CRJ10DJ0R0T

NOTE : "nsp" PART IS LISTED FOR REFERENCE ONLY, D&M WILL NOT SUPPLY THESE PARTS.

P.W.B. NAME	POS. NO.	VERS. COLOR	PART NO. (FOR EUR)	PART NO. (MZ)	PART NAME	DESCRIPTION
MAIN	R321		00MNN05100610	00MNN05100610	CHIP RES.	10 OHM 1/10W J CRJ10DJ100T
MAIN	R322		00MNN05183610	00MNN05183610	CHIP RES.	18K OHM 1/10W J CRJ10DJ183T
MAIN	R323		00MNN05183610	00MNN05183610	CHIP RES.	18K OHM 1/10W J CRJ10DJ183T
MAIN	R324		00MNN05183610	00MNN05183610	CHIP RES.	18K OHM 1/10W J CRJ10DJ183T
MAIN	R325		00MNN05471610	00MNN05471610	CHIP RES.	470 OHM 1/10W J CRJ10DJ471T
MAIN	R326		00MNN05822610	00MNN05822610	CHIP RES.	8.2K OHM 1/10W J CRJ10DJ822T
MAIN	R327		00MNN05332610	00MNN05332610	CHIP RES.	3.3K OHM 1/10W J CRJ10DJ332T
MAIN	R328		00MNN05221610	00MNN05221610	CHIP RES.	220 OHM 1/10W J CRJ10DJ221T
MAIN	R329		00MNN05332610	00MNN05332610	CHIP RES.	3.3K OHM 1/10W J CRJ10DJ332T
MAIN	R330		00MNN05000610	00MNN05000610	CHIP RES.	0 OHM 1/10W J CRJ10DJ0R0T
MAIN	R331		00MNN05103610	00MNN05103610	CHIP RES.	10K OHM 1/10W J CRJ10DJ103T
MAIN	R332		00MNN05103610	00MNN05103610	CHIP RES.	10K OHM 1/10W J CRJ10DJ103T
MAIN	R361		00MNN05000610	00MNN05000610	CHIP RES.	0 OHM 1/10W J CRJ10DJ0R0T
MAIN	R362		00MNN05000610	00MNN05000610	CHIP RES.	0 OHM 1/10W J CRJ10DJ0R0T
MAIN	R363		00MNN05000610	00MNN05000610	CHIP RES.	0 OHM 1/10W J CRJ10DJ0R0T
MAIN	R401		00MNN05221610	00MNN05221610	CHIP RES.	220 OHM 1/10W J CRJ10DJ221T
MAIN	R403		00MNN05100610	00MNN05100610	CHIP RES.	10 OHM 1/10W J CRJ10DJ100T
MAIN	R404		00MNN05220610	00MNN05220610	CHIP RES.	22 OHM 1/10W J CRJ10DJ220T
MAIN	R405		00MNN05000610	00MNN05000610	CHIP RES.	0 OHM 1/10W J CRJ10DJ0R0T
MAIN	R406		00MNN05222610	00MNN05222610	CHIP RES.	2.2K OHM 1/10W J CRJ10DJ222T
MAIN	R407		00MNN05182610	00MNN05182610	CHIP RES.	1.8K OHM 1/10W J CRJ10DJ182T
MAIN	R408		00MNN05392610	00MNN05392610	CHIP RES.	3.9K OHM 1/10W J CRJ10DJ392T
MAIN	R409		00MNN05221610	00MNN05221610	CHIP RES.	220 OHM 1/10W J CRJ10DJ221T
MAIN	R410		00MNN05680610	00MNN05680610	CHIP RES.	68 OHM 1/10W J CRJ10DJ680T
MAIN	R411		00MNN05104610	00MNN05104610	CHIP RES.	100K OHM 1/10W J CRJ10DJ104T
MAIN	R412		00MNN05000610	00MNN05000610	CHIP RES.	0 OHM 1/10W J CRJ10DJ0R0T
MAIN	R413		00MNN05000610	00MNN05000610	CHIP RES.	0 OHM 1/10W J CRJ10DJ0R0T
MAIN	R414		00MNN05473610	00MNN05473610	CHIP RES.	47K OHM 1/10W J CRJ10DJ473T
MAIN	R416		00MNN05473610	00MNN05473610	CHIP RES.	47K OHM 1/10W J CRJ10DJ473T
MAIN	R417		00MNN05183610	00MNN05183610	CHIP RES.	18K OHM 1/10W J CRJ10DJ183T
MAIN	R418		00MNN05470610	00MNN05470610	CHIP RES.	47 OHM 1/10W J CRJ10DJ470T
MAIN	R431		00MNN05122610	00MNN05122610	CHIP RES.	1.2K OHM 1/10W J CRJ10DJ122T
MAIN	R432		00MNN05103610	00MNN05103610	CHIP RES.	10K OHM 1/10W J CRJ10DJ103T
MAIN	R433		00MNN05473610	00MNN05473610	CHIP RES.	47K OHM 1/10W J CRJ10DJ473T
MAIN	R434		00MNN05472610	00MNN05472610	CHIP RES.	4.7K OHM 1/10W J CRJ10DJ472T
MAIN	R435		00MNN05101610	00MNN05101610	CHIP RES.	100 OHM 1/10W J CRJ10DJ101T
MAIN	R436		00MNN05153610	00MNN05153610	CHIP RES.	15K OHM 1/10W J CRJ10DJ153T
MAIN	R437		00MNN05472610	00MNN05472610	CHIP RES.	4.7K OHM 1/10W J CRJ10DJ472T
MAIN	R439		00MNN05473610	00MNN05473610	CHIP RES.	47K OHM 1/10W J CRJ10DJ473T
MAIN	R440		00MNN05223610	00MNN05223610	CHIP RES.	22K OHM 1/10W J CRJ10DJ223T
MAIN	SW41		90M-SS000710R	90M-SS000710R	SW	SLIDE SWITCH KSS2B016Z
MAIN	X101		943141007290M	943141007290M	CRYSTAL	CRYSTAL,SMD(48MHZ,FCX-03,SMD) COX00D3991127905-DM
MAIN	X201		90M-JX001330R	90M-JX001330R	X'TAL	27MHZ COX27000E180TF
MAIN	X251		90M-JX001390R	90M-JX001390R	X'TAL	16.934MHZ HOX16934A120C
MAIN			nsp	nsp	PCB	CD6003CDMAINPCBAUTOASS'Y CIP12190B
MAIN			nsp	nsp	PCB	CD6003CDMAINPCBSMDASS'Y CIP12190BSMD
MAIN			nsp	nsp	PCB	PCB,MAINCD6003(160*291,FR4/2) CUP12190Z
POWER.PWB(CUP12192Z-1)						
POWER	BK91		nsp	nsp	BRACKET	BRACKET FOR PWB CMD1A569
POWER	C903		nsp	00MOA22706320	ELECT CAP.	220UF 63V CCEA1JH221E
POWER	C904		nsp	nsp	FILM CAP.	0.1UF 100V CCUMT2A104KB
POWER	C905		nsp	00MOA22505020	ELECT CAP.	2.2UF 50V CCEA1HH2R2T
POWER	C906		nsp	00MOA10605020	ELECT CAP.	10UF 50V CCEA1HH100T
POWER	C907		nsp	nsp	CER. CAP.	0.1UF 50V Z CERAMIC CCBS1H104ZFT
POWER	C908		nsp	nsp	CER. CAP.	0.1UF 50V Z CERAMIC CCBS1H104ZFT
POWER	C909		nsp	90M-OA000620R	ELECT CAP.	KR3 25V/6800UF 18X35 CCEA1EH682E
POWER	C910		nsp	nsp	CER. CAP.	0.1UF 50V Z CERAMIC CCBS1H104ZFT
POWER	C911		nsp	00MOA22801620	ELECT CAP.	2200UF 16V CCEA1CH222E
POWER	C912		nsp	00MOA10801620	ELECT CAP.	1000UF 16V CCEA1CH102E
POWER	C913		nsp	00MOA10802520	ELECT CAP.	1000UF 25V CCEA1EH102E
POWER	C914		nsp	nsp	CER. CAP.	0.022UF 50V Z CERAMIC CCBS1H223ZFT
POWER	C915		nsp	00MOA33802520	ELECT CAP.	3300UF 25V CCEA1EH332E
POWER	C916		nsp	00MOA47701620	ELECT CAP.	470UF 16V ZF CCEA1CH471T
POWER	C917		nsp	00MOB10803570	ELECT CAP.	1000U 35V(ALP) (LF)-BLOCK CAP CCEA1VLAO102E
POWER	C918		nsp	00MOA47602520	ELECT CAP.	47UF 25V CCEA1EH470T
POWER	C919		nsp	00MOA47701620	ELECT CAP.	470UF 16V ZF CCEA1CH471T
POWER	C920		nsp	00MOB10803570	ELECT CAP.	1000U 35V(ALP) (LF)-BLOCK CAP CCEA1VLAO102E
POWER	C921		nsp	00MOA47602520	ELECT CAP.	47UF 25V CCEA1EH470T
POWER	C922		nsp	00MOA47701620	ELECT CAP.	470UF 16V ZF CCEA1CH471T
POWER	▲ C923		00MOA22801620	00MOA22801620	ELECT CAP.	2200UF 16V CCEA1CH222E
POWER	▲ C924		00MOA10702520	00MOA10702520	ELECT CAP.	100UF 25V CCEA1EH101T
POWER	▲ C925		90M-DK100770R	90M-DK100770R	CER. CAP.	! 0.0047UF 2.5KV CERAMIC KCKDKS472ME
POWER	CN91		nsp	nsp	CONN.	2P 7.92MM(YUNHO) CJP02KA060ZY
POWER	CN92		nsp	nsp	CONN.	2P WAFER CJP02GA89ZY
POWER	CN93		nsp	nsp	WAFER	LOCKINGTYPE, STRAIGHTWAFER, 2MM CJP07G1236ZW

NOTE : "nsp" PART IS LISTED FOR REFERENCE ONLY, D&M WILL NOT SUPPLY THESE PARTS.

P.W.B. NAME	POS. NO.	VERS. COLOR	PART NO. (FOR EUR)	PART NO. (MZ)	PART NAME	DESCRIPTION
POWER	CN94		nsp	nsp	WAFER	LOCKINGTYPE, STRAIGHTWAFER, 2.5MM
POWER	D901		90M-HD201730R	90M-HD201730R	DIODE	1N4003
POWER	D902		943209005450M	943209005450M	DIODE	DIODE,RECT(2A)
POWER	D903		943209005450M	943209005450M	DIODE	DIODE,RECT(2A)
POWER	D904		943209005450M	943209005450M	DIODE	DIODE,RECT(2A)
POWER	D905		943209005450M	943209005450M	DIODE	DIODE,RECT(2A)
POWER	D906		90M-HD201730R	90M-HD201730R	DIODE	1N4003
POWER	D907		90M-HD201730R	90M-HD201730R	DIODE	1N4003
POWER	D908		90M-HD201730R	90M-HD201730R	DIODE	1N4003
POWER	D909		90M-HD201730R	90M-HD201730R	DIODE	1N4003
POWER	D910		90M-HD201730R	90M-HD201730R	DIODE	1N4003
POWER	D911		90M-HD201730R	90M-HD201730R	DIODE	1N4003
POWER	D912		90M-HD201730R	90M-HD201730R	DIODE	1N4003
POWER	D913		90M-HD201730R	90M-HD201730R	DIODE	1N4003
POWER	D914		90M-HD201730R	90M-HD201730R	DIODE	1N4003
POWER	D915		90M-HD201730R	90M-HD201730R	DIODE	1N4003
POWER	▲ D916		00MHD20055100	00MHD20055100	DIODE	! SHOTTKY 11EQS10 1A 100V
POWER	▲ D917		00MHD20055100	00MHD20055100	DIODE	! SHOTTKY 11EQS10 1A 100V
POWER	▲ D918		00MHD20055100	00MHD20055100	DIODE	! SHOTTKY 11EQS10 1A 100V
POWER	▲ D919		00MHD20055100	00MHD20055100	DIODE	! SHOTTKY 11EQS10 1A 100V
POWER	D920		90M-HD201730R	90M-HD201730R	DIODE	1N4003
POWER	D921		90M-HD302440R	90M-HD302440R	ZENER DIODE	ZJ4.7B 1/2W
POWER	D922		90M-HD302350R	90M-HD302350R	DIODE	DIODE ZENER ZJ27B1/2W
POWER	D923		90M-HD201730R	90M-HD201730R	DIODE	1N4003
POWER	D924		90M-HD302450R	90M-HD302450R	ZENER DIODE	ZJ13B 1/2W
POWER	D925		00MHD20015210	00MHD20015210	DIODE	1SS133T-77
POWER	D926		90M-HD302450R	90M-HD302450R	ZENER DIODE	ZJ13B 1/2W
POWER	D927		00MHD20015210	00MHD20015210	DIODE	1SS133T-77
POWER	▲ D928		00MHD20015210	00MHD20015210	DIODE	1SS133T-77
POWER	D929		90M-HD302480R	90M-HD302480R	ZENER DIODE	ZJ15B 1/2W
POWER	D930		943209005450M	943209005450M	DIODE	DIODE, RECT(2A)
POWER	D931		943209005450M	943209005450M	DIODE	DIODE, RECT(2A)
POWER	D932		943209005450M	943209005450M	DIODE	DIODE, RECT(2A)
POWER	D933		943209005450M	943209005450M	DIODE	DIODE, RECT(2A)
POWER	D934		90M-HD201730R	90M-HD201730R	DIODE	1N4003
POWER	▲ F901	FN	nsp	90M-FS001370R	FUSE	! 250V T 0.63A
POWER	▲ F901	K1SG	nsp	90M-FS001260R	FUSE	! T 315MA L 250V
POWER	▲ F901	N1	90M-FS001260R	90M-FS001260R	FUSE	! T 315MA L 250V
POWER	▲ F902		90M-FS001070R	90M-FS001070R	FUSE	! AC250V T2.5AL
POWER	▲ F903		90M-FS001530R	90M-FS001530R	FUSE	! FUSE 0.8A 372 SERIES/TR5
POWER	▲ F904		90M-FS001530R	90M-FS001530R	FUSE	! FUSE 0.8A 372 SERIES/TR5
POWER	IC91		90M-HC300950R	90M-HC300950R	IC	KIA78R08 REGULATOR(TO220IS-4)
POWER	J901		nsp	nsp	CORD	SN95/PB5 0.6
POWER	J902		nsp	nsp	CORD	SN95/PB5 0.6
POWER	J903		nsp	nsp	CORD	SN95/PB5 0.6
POWER	J904		nsp	nsp	CORD	SN95/PB5 0.6
POWER	J905		nsp	nsp	CORD	SN95/PB5 0.6
POWER	J906		nsp	nsp	CORD	SN95/PB5 0.6
POWER	J907		nsp	nsp	CORD	SN95/PB5 0.6
POWER	J908		nsp	nsp	CORD	SN95/PB5 0.6
POWER	J910		nsp	nsp	CORD	SN95/PB5 0.6
POWER	J911		nsp	nsp	CORD	SN95/PB5 0.6
POWER	J912		nsp	nsp	CORD	SN95/PB5 0.6
POWER	J913		nsp	nsp	CORD	SN95/PB5 0.6
POWER	J914		nsp	nsp	CORD	SN95/PB5 0.6
POWER	J915		nsp	nsp	CORD	SN95/PB5 0.6
POWER	J916		nsp	nsp	CORD	SN95/PB5 0.6
POWER	J917		nsp	nsp	CORD	SN95/PB5 0.6
POWER	J918		nsp	nsp	CORD	SN95/PB5 0.6
POWER	J919		nsp	nsp	CORD	SN95/PB5 0.6
POWER	J920		nsp	nsp	CORD	SN95/PB5 0.6
POWER	J921		nsp	nsp	CORD	SN95/PB5 0.6
POWER	J922		nsp	nsp	CORD	SN95/PB5 0.6
POWER	J923		nsp	nsp	CORD	SN95/PB5 0.6
POWER	J991		nsp	nsp	CORD	SN95/PB5 0.6
POWER	J998		nsp	nsp	CORD	SN95/PB5 0.6
POWER	Q901		943219006820S	943219006820S	T.R	T.R
POWER	▲ Q904		00MHT30001000	00MHT30001000	TRS.	KTC3199Y
POWER	▲ Q905		00MHT30001000	00MHT30001000	TRS.	KTC3199Y
POWER	R901		00MGD05101160	00MGD05101160	RES.	100 OHM 1/6W J CARBON
POWER	R902		00MGD05101160	00MGD05101160	RES.	100 OHM 1/6W J CARBON
POWER	R903		00MGD05223160	00MGD05223160	RES.	22K OHM 1/6W J CARBON
POWER	R904		nsp	nsp	RES.	RES, METALOXIDEFILM
POWER	R905		00MGD05682160	00MGD05682160	RES.	RES, METALOXIDEFILM
POWER	R906		00MGD05123160	00MGD05123160	RES.	12K OHM 1/6W J CARBON
POWER	R907		00MGD05473160	00MGD05473160	RES.	47K OHM 1/6W J CARBON

NOTE : "nsp" PART IS LISTED FOR REFERENCE ONLY, D&M WILL NOT SUPPLY THESE PARTS.

P.W.B. NAME	POS. NO.	VERS. COLOR	PART NO. (FOR EUR)	PART NO. (MZ)	PART NAME	DESCRIPTION
POWER	R908		00MGD05222160	00MGD05222160	RES.	2.2K OHM 1/6W J CARBON CRD20TJ222T
POWER	R909		00MGD05222160	00MGD05222160	RES.	2.2K OHM 1/6W J CARBON CRD20TJ222T
POWER	R910		00MGD05103160	00MGD05103160	RES.	10K OHM 1/6W J CARBON CRD20TJ103T
POWER	R911		00MGD05332160	00MGD05332160	RES.	3.3K OHM 1/6W J CARBON CRD20TJ332T
POWER	R913		nsp	nsp	CORD	SN95/PB5 0.6 C3A206
POWER	R914		00MGD05102160	00MGD05102160	RES.	1K OHM 1/6W J CARBON CRD20TJ102T
POWER	R915		00MGD05272160	00MGD05272160	RES.	2.7K OHM 1/6W J CARBON CRD20TJ272T
POWER	R916		00MGD05822160	00MGD05822160	RES.	8.2K OHM 1/6W J CARBON CRD20TJ822T
POWER	R917		00MGD05104160	00MGD05104160	RES.	100K OHM 1/6W J CARBON CRD20TJ104T
POWER	R918		00MGD05103160	00MGD05103160	RES.	10K OHM 1/6W J CARBON CRD20TJ103T
POWER	R919		nsp	nsp	RES.	RES.METALOXIDEFILM KRG1SANJ332RT
POWER	▲ RY91		943682004660S	943682004660S	RELAY	! RELAY G5PA-1 DC6V CSL1E002ZE
POWER	▲ T902	FN	nsp	90M-TS003170R	TRANSF.	# TRANSF. SUB CD6002/F CLT5I009ZJ
POWER	▲ T902	K1SG	nsp	943101007210M	TRANSF.	TRANS.SUBCD6003/K CLT5I009ZH
POWER	▲ T902	N1	90M-TS003180R	90M-TS003180R	TRANSF.	# TRANSF. SUB CD6002/N CLT5I009ZE
POWER	29,31		nsp	nsp	PCB	CD6003/NCDAUDIO+POWERPCBASS'Y COP12192B
POWER	C991		00MDK96104300	00MDK96104300	CER. CAP.	0.1UF 50V K CCUS1H104KC
POWER	C992		00MDK96104300	00MDK96104300	CER. CAP.	0.1UF 50V K CCUS1H104KC
POWER	C993		00MDK96104300	00MDK96104300	CER. CAP.	0.1UF 50V K CCUS1H104KC
POWER	C996		00MDK96104300	00MDK96104300	CER. CAP.	0.1UF 50V K CCUS1H104KC
POWER	C997		00MDK96104300	00MDK96104300	CER. CAP.	0.1UF 50V K CCUS1H104KC
					TRANSF.PWB(CUP12192Z-3)	
TRANSF	BN92		nsp	nsp	WIRE	WIREASSY(2P,200MM,#18) CWB4F932200UZ
TRANSF	BN93		nsp	nsp	WIRE	WIREASSY(LOCK,7P,150MM,2.0MM) CWB1C00715047
TRANSF	BN94		nsp	nsp	WIRE	WIREASSY(LOCK,3P,120MM,2.5MM) CWB1D00312058
TRANSF	T901(26)	FN	nsp	90M-TS003150R	TRANSF.	# TRANSF. POWER CD6002 100V/50HZ CLT5N035ZJ
TRANSF	T901(26)	K1SG	nsp	90M-TS003160R	TRANSF.	# TRANSF. POWER CD6002 230V/50HZ CLT5N035ZE
TRANSF	T901(26)	N1	90M-TS003160R	90M-TS003160R	TRANSF.	# TRANSF. POWER CD6002 230V/50HZ CLT5N035ZE

NOTE : "nsp" PART IS LISTED FOR REFERENCE ONLY, D&M WILL NOT SUPPLY THESE PARTS.