

SERVICE
MANUAL

CD-73



marantz®

model CD-73

Compact Disc Player

TABLE OF CONTENTS

SECTION	PAGE
1. INTRODUCTION	1
2. P. W. BOARDS	1
3. DRAWER MOTOR CONTROL P. W. BOARD WORKING PRINCIPLE	2
4. ADJUSTMENT PROCEDURES FOR DISC CLAMPER	3
5. VOLTAGE CONVERSION	4
6. SIGNAL BLOCK DIAGRAM	5
7. COMPONENT LOCATIONS (AND WIRE CONNECTIONS)	6
8. DIAGRAM AND COMPONENT LOCATIONS	8
8.1 Servo (P200) Schematic Diagram and Component Locations	8
8.2 Decoder (P500) Schematic Diagram and Component Locations	13
8.3 Power Supply (P100) Schematic Diagram and Component Locations	18
8.4 Pre Amp. + Laser (AY40) Schematic Diagram and Component Locations	19
9. EXPLODED VIEW AND PARTS LIST	22
10. ELECTRICAL PARTS LIST	30
11. TECHNICAL SPECIFICATIONS	38
12. SCHEMATIC DIAGRAM	40

MODEL CD-73 COMPACT DISC PLAYER

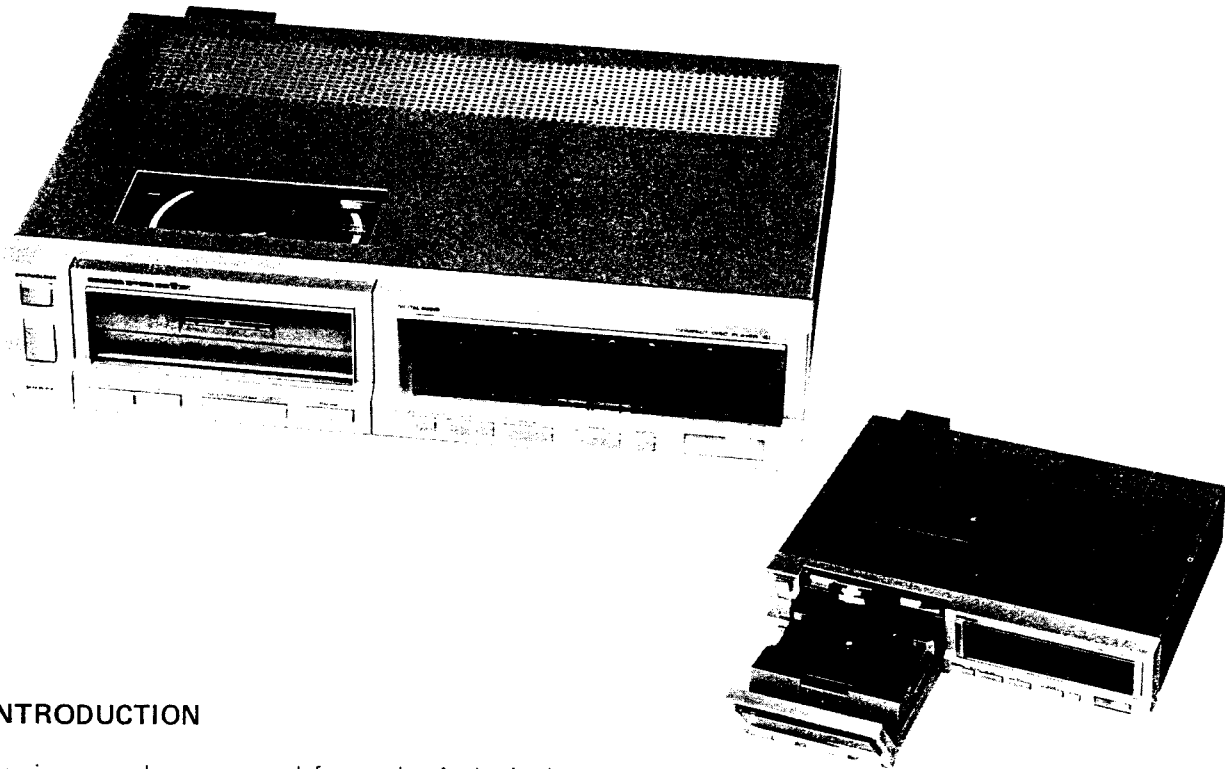

1. INTRODUCTION

This service manual was prepared for use by Authorized Warranty Stations and contains service information for Marantz Model CD-73 Compact Disc Player.

Servicing information and voltage data included in this manual are intended for use by the knowledgeable and experienced technician only. All instructions should be read carefully. No attempt should be made to proceed without a good understanding of the operation of the Compact Disc Player.

The parts list furnishes information by which replacement parts may be ordered from the Marantz Company. A simple description is included for parts which can usually be obtained through local suppliers.

2. P. W. BOARDS

1. Power Supplymounted on P.W. Board P100
2. Servomounted on P.W. Board P200
3. Decodermounted on P.W. Board P500
4. Motor/Remoconmounted on P.W. Board P800
5. Main Filtermounted on P.W. Board PH00
6. Power Indicatormounted on P.W. Board PR00
7. Disc Inside Indicatormounted on P.W. Board PR50
8. Program Key Switchmounted on P.W. Board PS00
9. Mode Key Switchmounted on P.W. Board PU00
10. Signal Relay 2mounted on P.W. Board PU50
11. Displaymounted on P.W. Board PY00
12. Mode Indicatormounted on P.W. Board PZ00
13. Signal Relay 1mounted on P.W. Board PZ50

14. Pre Amp. + Lasermounted on P.W. Board AY40

3. DRAWER MOTOR CONTROL P. W. BORAD WORKING PRINCIPLE

Drawer motor control P. W. Borad includes the following.

- (1) Drawer motor drive circuit
- (2) Remote control circuit (Marantz Bus System decoder circuit)

3.1 Drawer Motor Drive Circuit

A. Outline of the system

This circuit revolves and reverses the drawer motor by the OPEN/CLOSE switch of S802 on the front panel to open and close the drawer. It includes a circuit to increase starting torque and a safety circuit which stops automatically when something is caught in the drawer.

B. Operation of each part

- a) Q809, Q808 and Q807 are motor drive circuits. Especially Q808 increases motor starting torque.
- b) When the voltage of R820 becomes over about 0.6V, the base current begins to flow through Q803. That is, the motor is locked to detect the excessive current.
- c) Q805 and Q806 make up a set/reset flip flop, which is set when positive voltage is put into the base of Q805. And it is reset when the base becomes 0. As long as it is set, D806 is "ON" and motor drive circuit does not operate.
- d) Q802 becomes "ON" just for a few msec when the OPEN/CLOSE switch of S802 is pushed. (S802 is non-shorting type.)

- e) Q801 becomes "ON" just for the time-constant t_1 based on R816/R801/C801 only after S802 is changed from CLOSE to OPEN, and makes the base of Q809 0V to stop the motor drive circuit. Meanwhile, the voltage of C807 is discharged to increase the torque for the time-constant t_2 of C807/R822 just after the end of t_1 .

C. Explanation of overall operation

- a) During the shift of OPEN/CLOSE switch S802, from OPEN to CLOSE, Q802 becomes "ON" in an instant and flip flop which is composed of Q805 and Q806 is reset to cut off D806.
- b) Consequently motor drive circuit which is composed of Q809, Q808 and Q807 begins to operate to switch on the drawer motor.
- c) When the drawer comes to the mechanical end, short-circuit current begins to flow to the motor to generate voltage of R820 about 1V. This voltage reverses Q803 to cut off D804.
- d) After D804 is cut off, C805 is discharged through R807 and Q804, and Q804 becomes OFF after about 2.5 sec.
- e) As a result, the collector voltage of Q804 rises to set the above flip flop through R809/R810. In this way, the motor drive circuit becomes OFF again.
- f) You have the same operation also when S802 is changed from CLOSE to OPEN. But Q801 has been added so that Q808 which increases start up torque can become ON without fail.

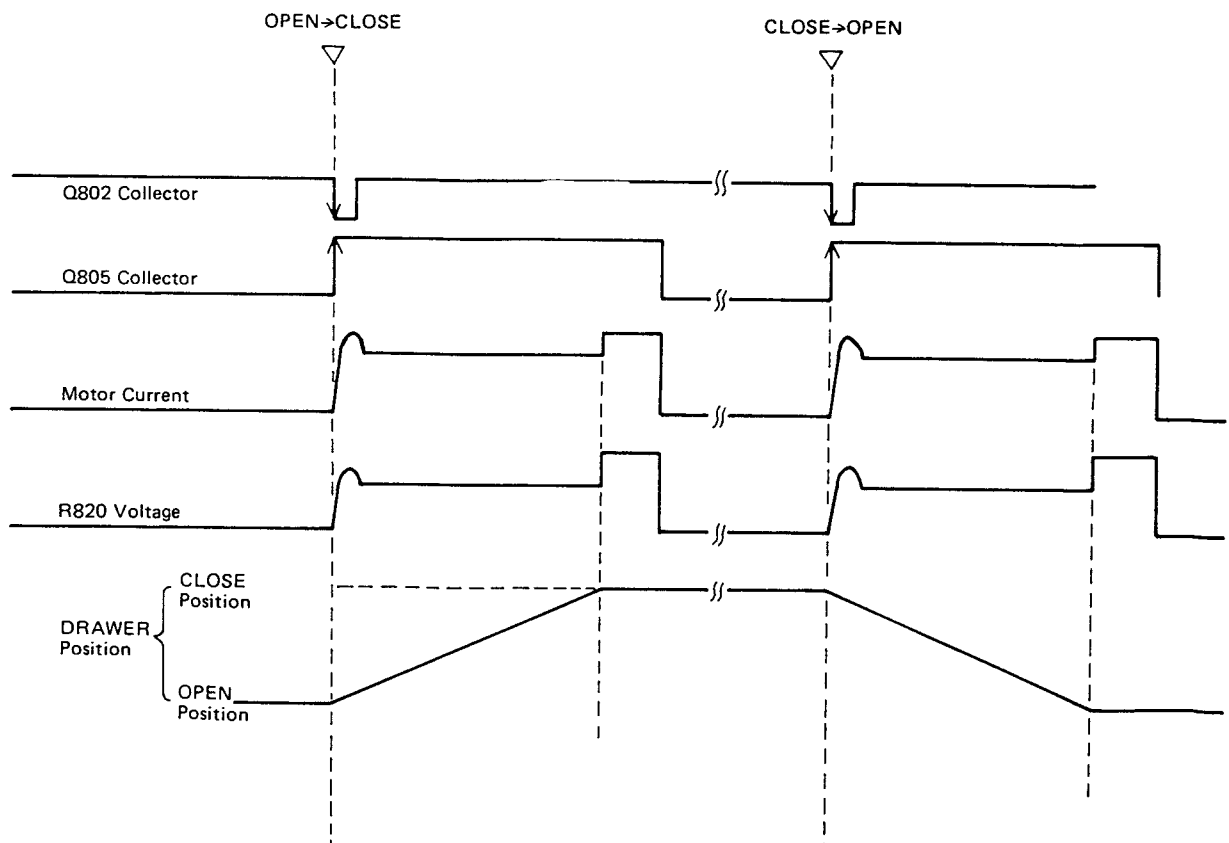

3.2 Remote Control Circuit

A. Outline of the system

Marantz Bus System is a general term to this remote control circuit. Remocon transmitter and remocon receiver are necessary to operate it.

The output of the remocon receiver is connected to the remocon "IN" terminal on the rear panel of the CD-73. The remocon transmitter has 4 keys for play/next, pause, repeat and stop.

B. Operation of each part

- a) Q851 is N channel Micro Processor for remocon.
- b) Q857 amplifies a signal from the remocon receiver and transmits it to pin 24 of the Micro Processor.
- c) Q858 is a transistor switch. When a laser signal "S" becomes Low level, it switches "ON" and changes the Micro Processor pin 25 to High level to generate an easy operation signal at pin 19.
This easy operation signal is reversed at Q856 and put out from the easy "OUT" terminal of the CD-73. This signal makes easy operation possible.
- d) Q853, Q854 and Q855 are used as analogue switches and controlled by output pin 9, 10 and 15 respectively. Q852 is a transistor switch, which lowers a sense signal to GND level to stop operation.
- e) R852/D851/C856 are used for initial setting of the Micro Processor.

C. Overall operation

When any key of the remocon transmitter is pushed, a pulse signal is transmitted to the CD-73 remote "IN" terminal through the remocon receiver. This signal is put into the Micro Processor pin 24 after being amplified at Q857 and the Micro Processor comes to correspond to the key to generate High signal at the output pin as follows.

play/next	pin 9
pause	pin 10
repeat	pin 15
stop	pin 4

Besides, only when the play/next key is pushed, an easy operation signal occurs at pin 19 for 60 msec to mute the other sources.

4. ADJUSTMENT PROCEDURES FOR DISC CLAMPER

4.1 Adjusting the height of the pressure ring holder

The height of the holder must be adjusted to maintain braking by keeping the appropriate distance between the holder and pressure ring.

With the drawer in the unit, lift the holder manually, and place the positioning tool on the turntable. If the drawer is in the "out" position, the aluminum cap will come in contact with the front chassis and front panel, and will be scratched when the drawer is pushed into the unit.

With a screwdriver, turn the adjustment screw clockwise 2 or 3 turns. Push down the holder several times to confirm that it sinks a few millimeters until it makes contact with the positioning tool. If there is no play between the holder and tool, turn the adjustment screw further until a few millimeters play is obtained.

Turn the adjustment screw counterclockwise until the play between the holder and tool becomes zero. For optimum adjustment, do not exert excess pressure on the adjustment screw with the screwdriver.

Apply lock paint to the adjustment screw.

Lift the holder with the drawer in the "in" position, and remove the positioning tool.

5. VOLTAGE CONVERSION

• EUROPEAN MODEL ONLY

To convert the unit to a different power source voltage, change the position as illustrated in the drawing below.

CAUTION
DISCONNECT POWER SUPPLY CORD FROM AC
OUTLET BEFORE CONVERTING VOLTAGE.

Voltage Conversion Chart

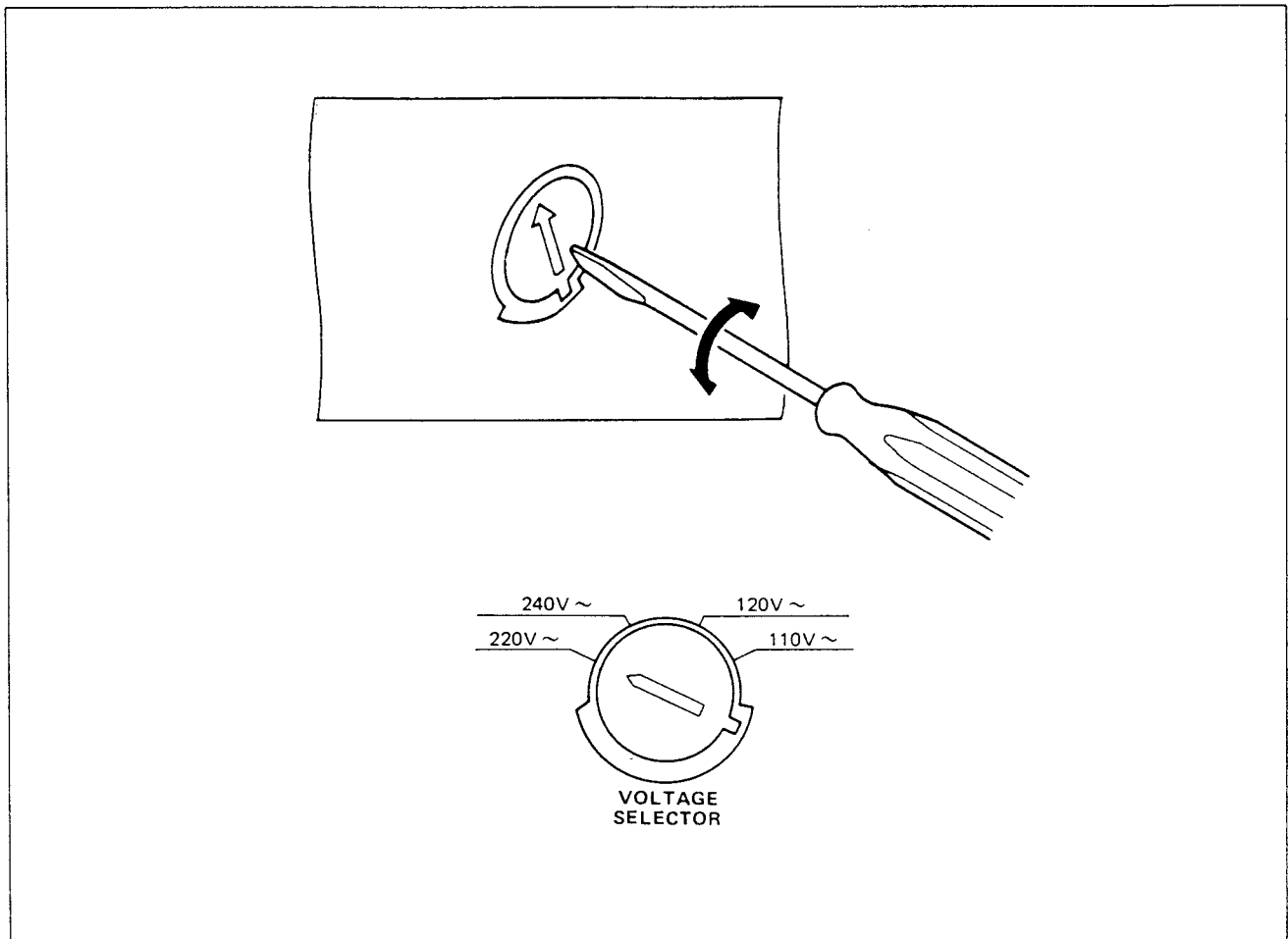

Note on safety: Symbol \triangle Fire or electrical shock hazard. Only original parts should be used to replace any part marked with symbol \triangle . Any other component substitution (other than original type), may increase risk of fire or electrical shock hazard.

6. SIGNAL BLOCK DIAGRAM

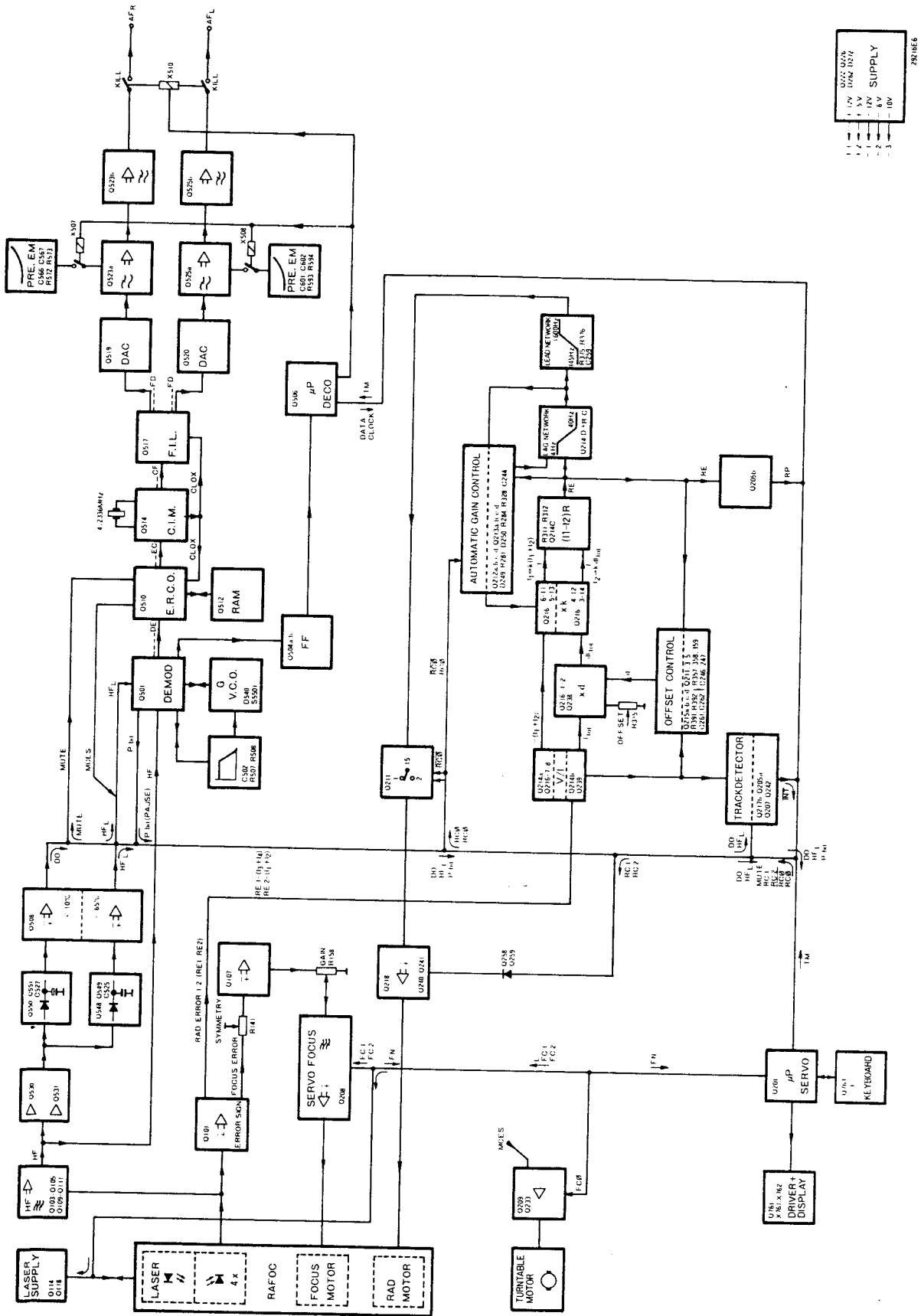

Pin	Supply
1	5V
2	5V
3	5V
4	5V
5	5V
6	5V
7	5V
8	5V
9	5V
10	5V

m 3590

7. COMPONENT LOCATIONS (AND WIRE CONNECTIONS)

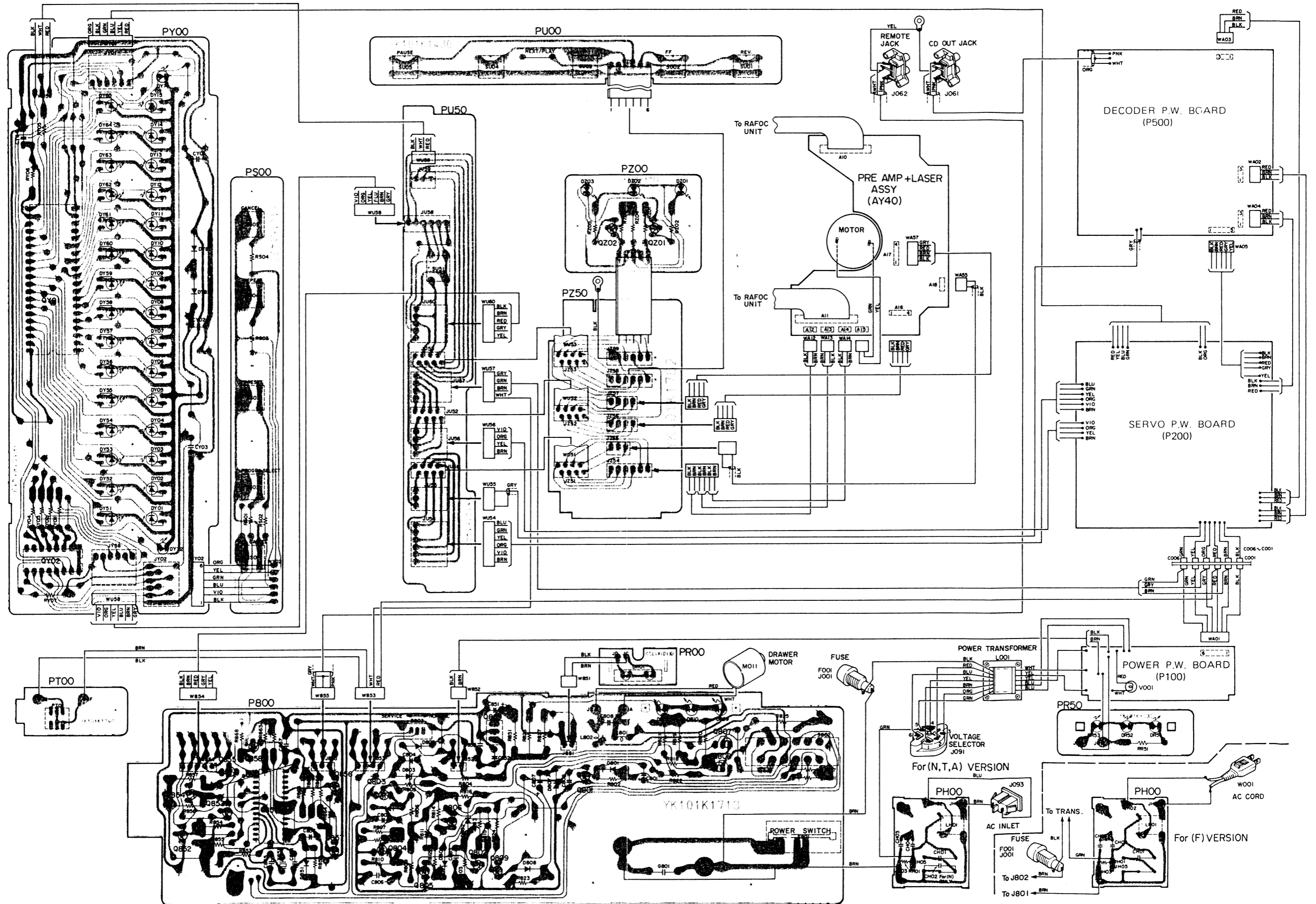

8. DIAGRAM AND COMPONENT LOCATIONS

8.1 Servo (P200) Schematic Diagram and Component Locations

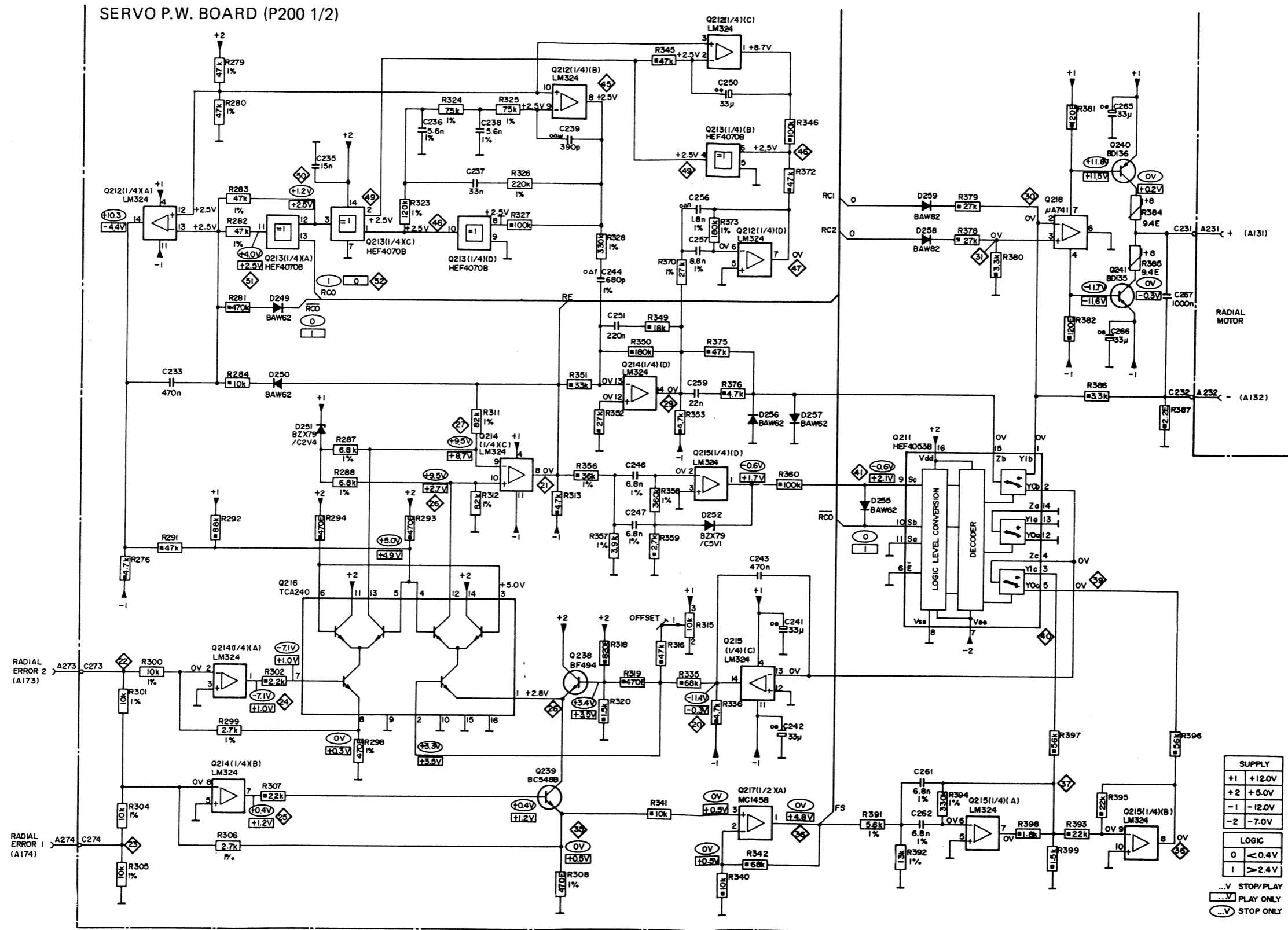

m 3592

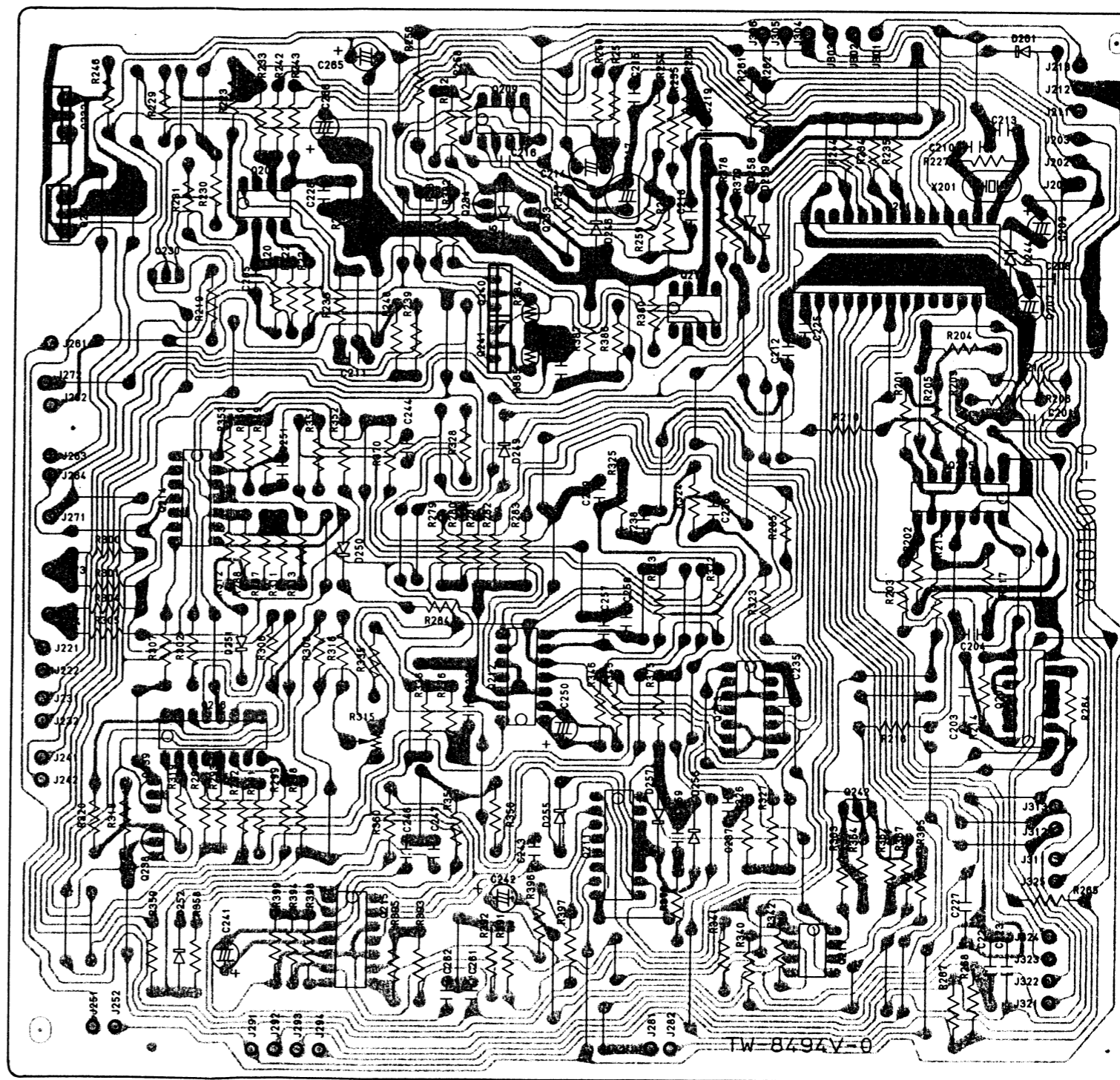
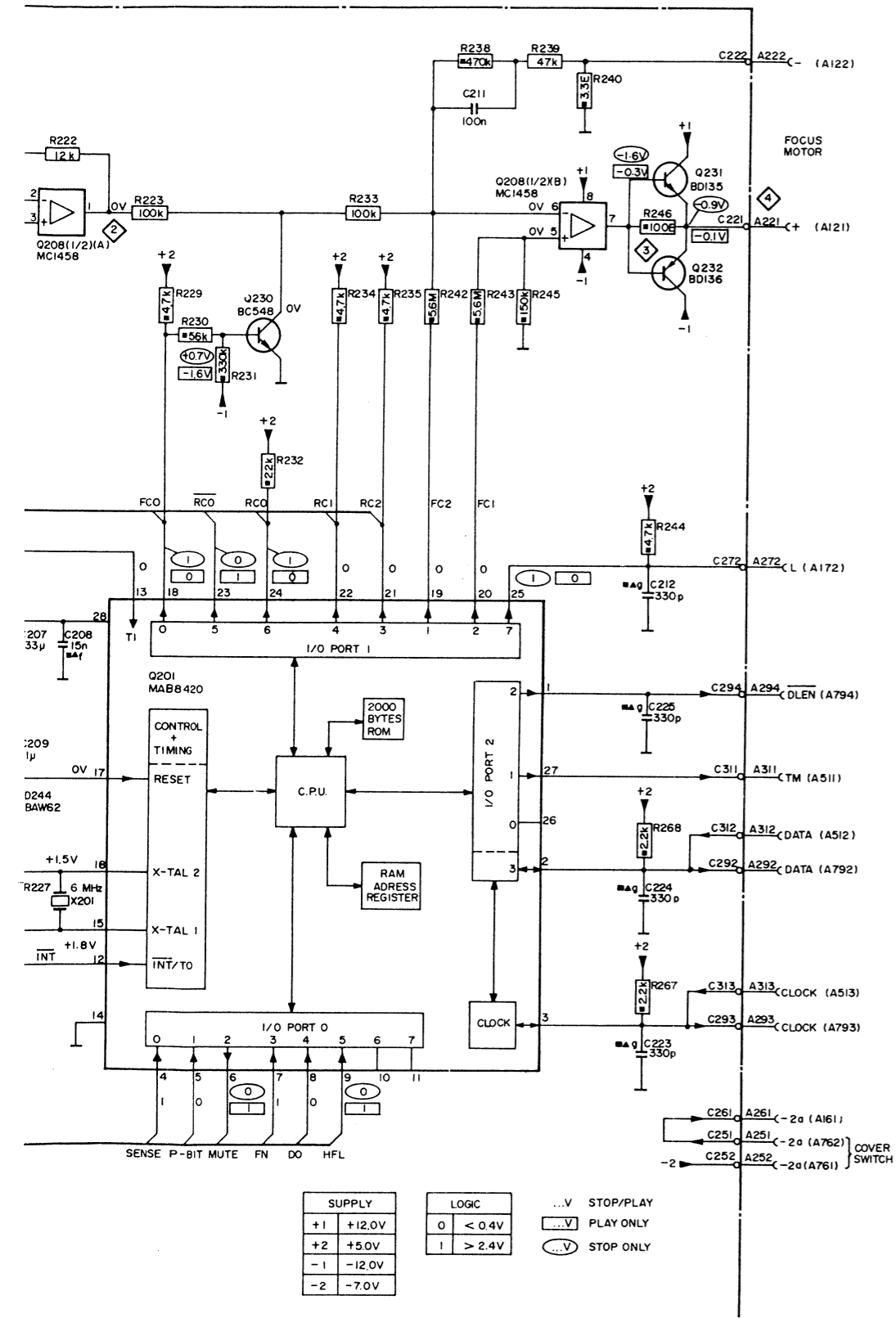

8.2 Decoder (P500) Schematic Diagram and Component Locations

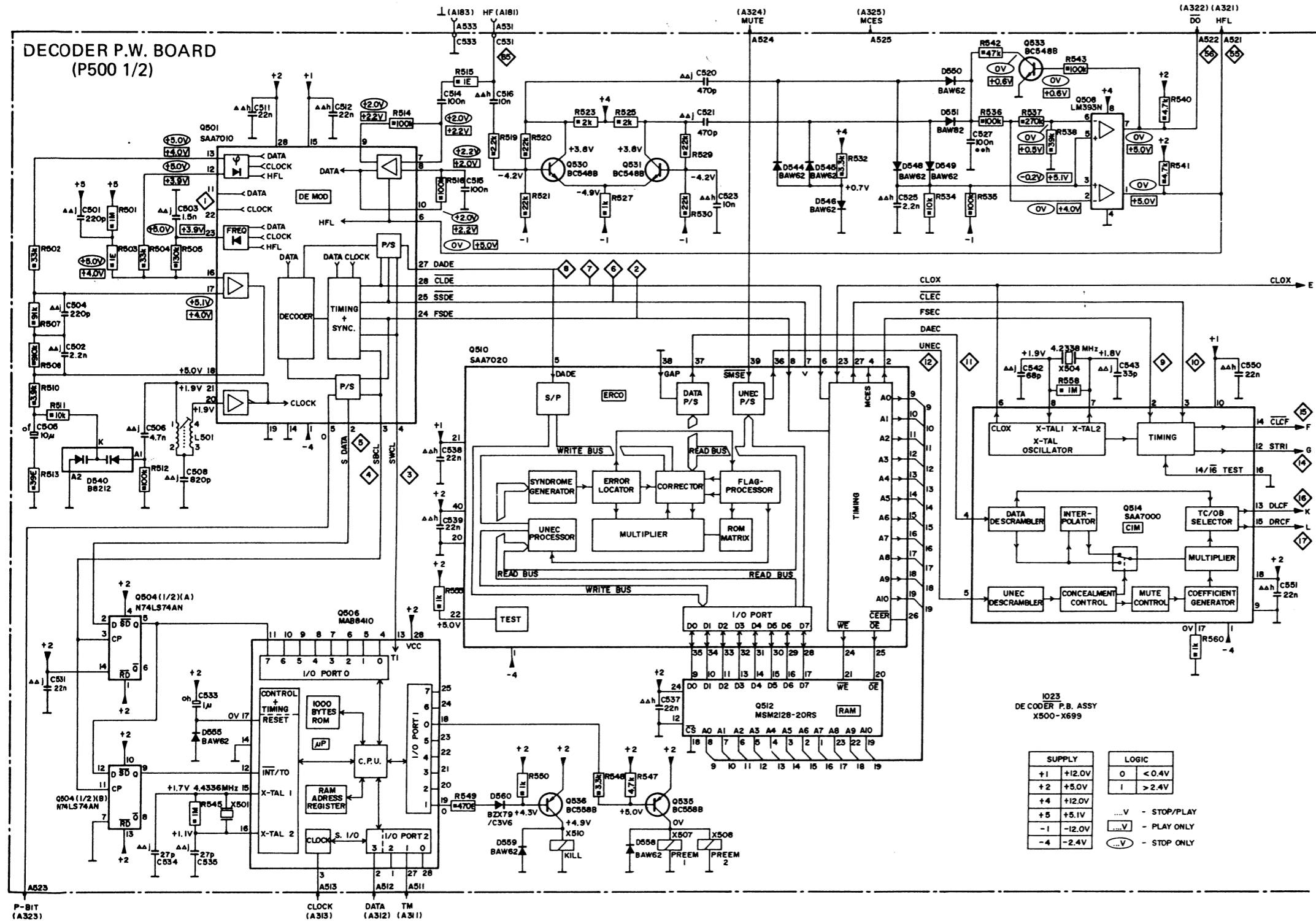

DECODER P.W. BOARD (P500 2/2)

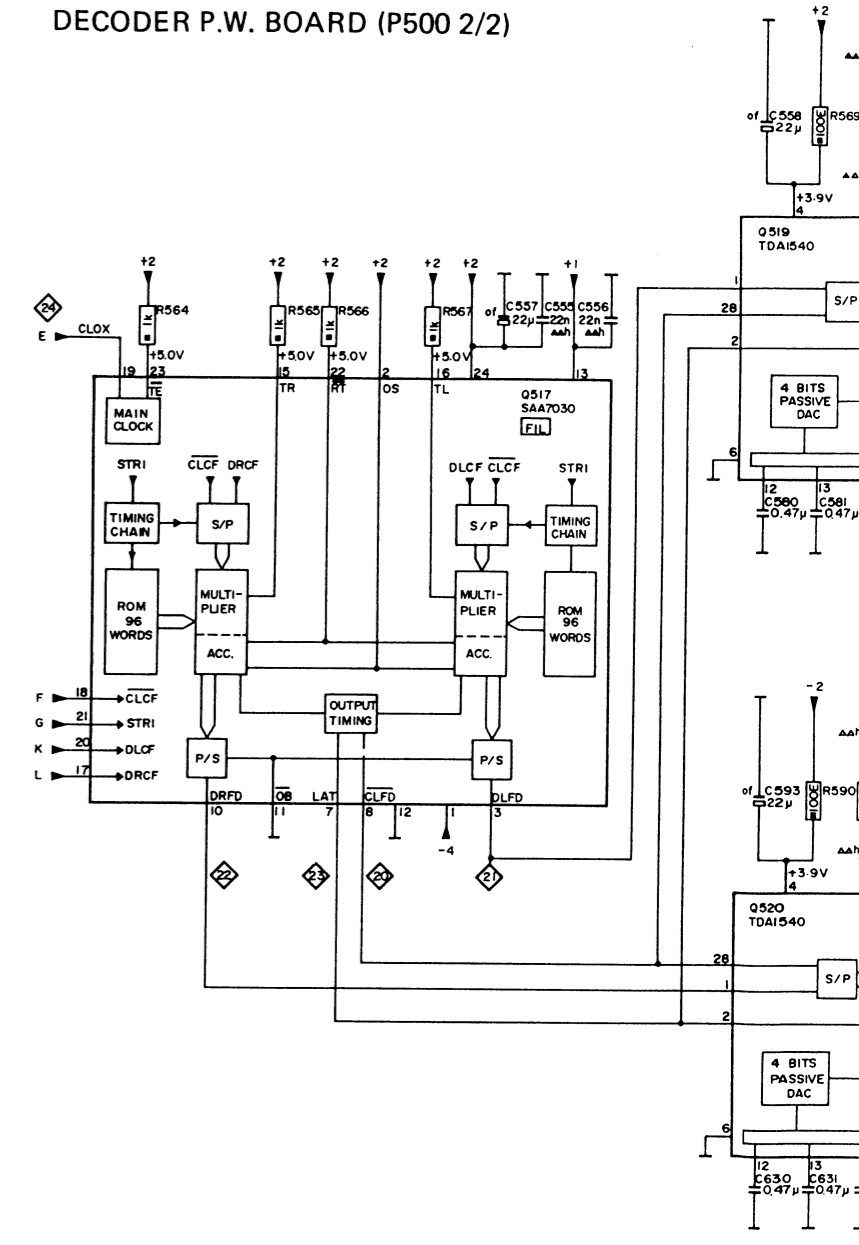

m 3594

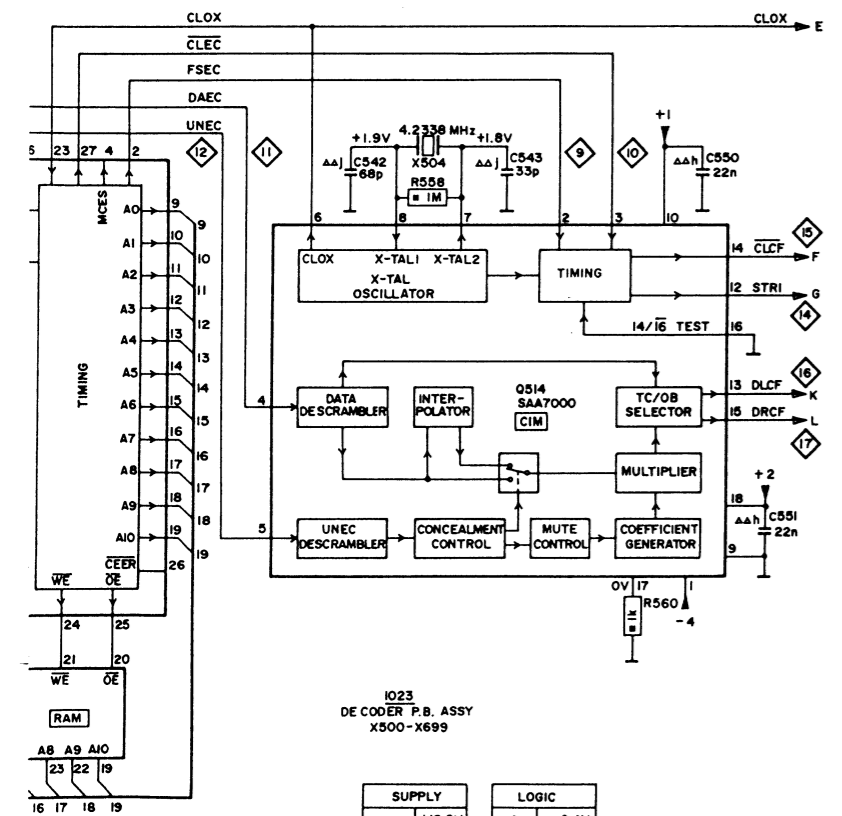
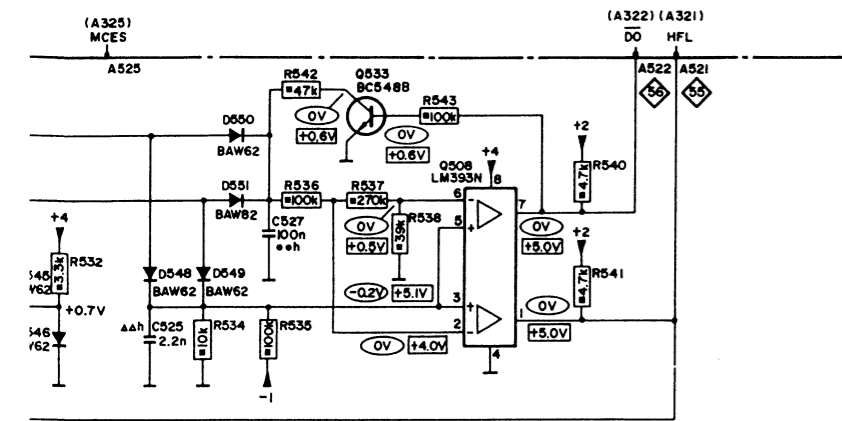

I023
DE COOER P.B. ASSY
X500-X699

SUPPLY		LOGIC	
+1	+12.0V	0	< 0.4V
+2	+5.0V	1	> 2.4V
+4	+12.0V	...	- STOP/PLAY
+5	+5.1V	...	- PLAY ONLY
-1	-12.0V	...	- STOP ONLY
-4	-2.4V	...	- STOP ONLY

DECODER P.W. BOARD (P500 2/2)

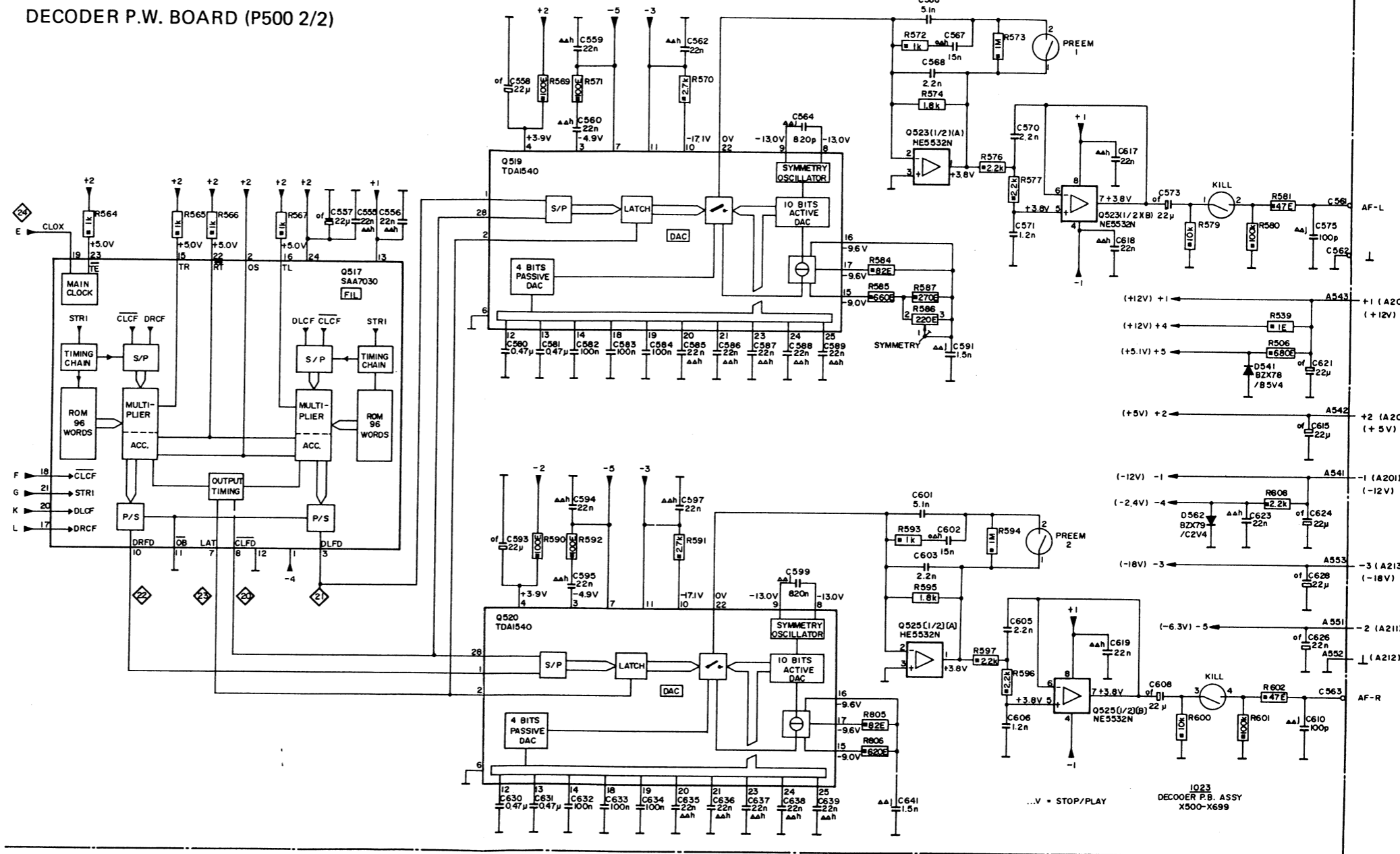

I023
DECOER P.B. ASSY
X500-X699

...V = STOP/PLAY

8.3 Power Supply (P100) Schematic Diagram and Component Locations

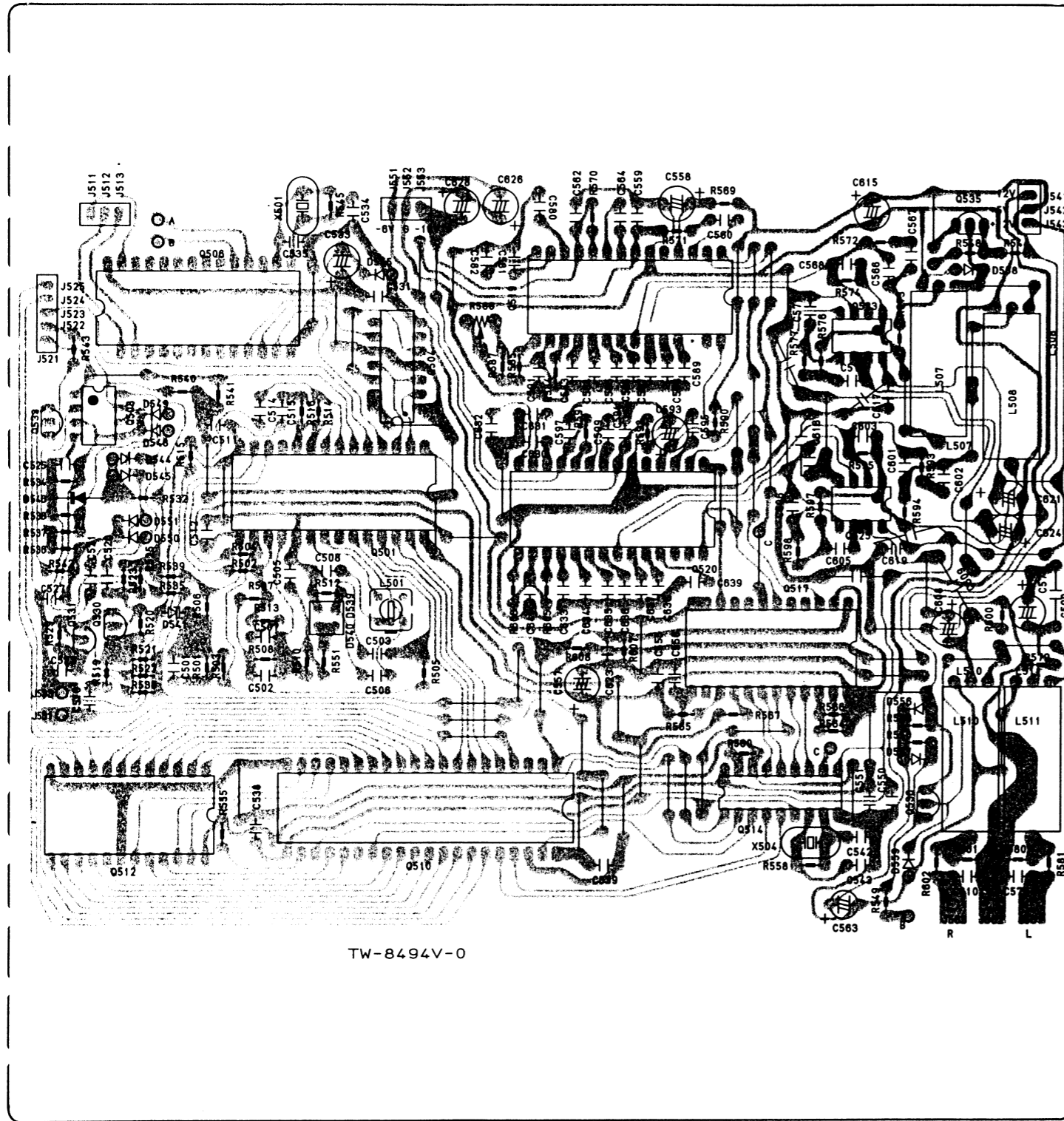

POWER P.W. BOARD (P100)

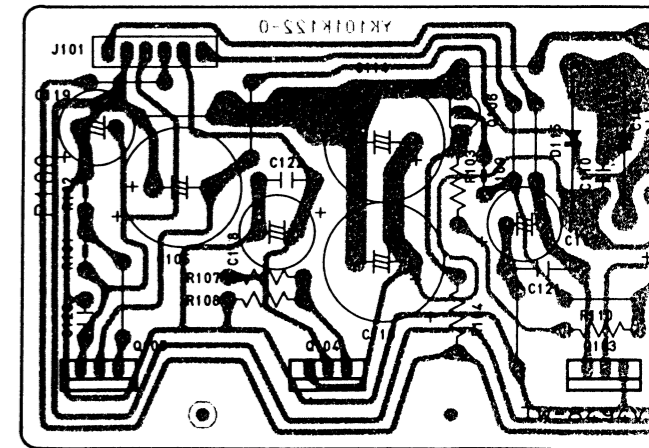
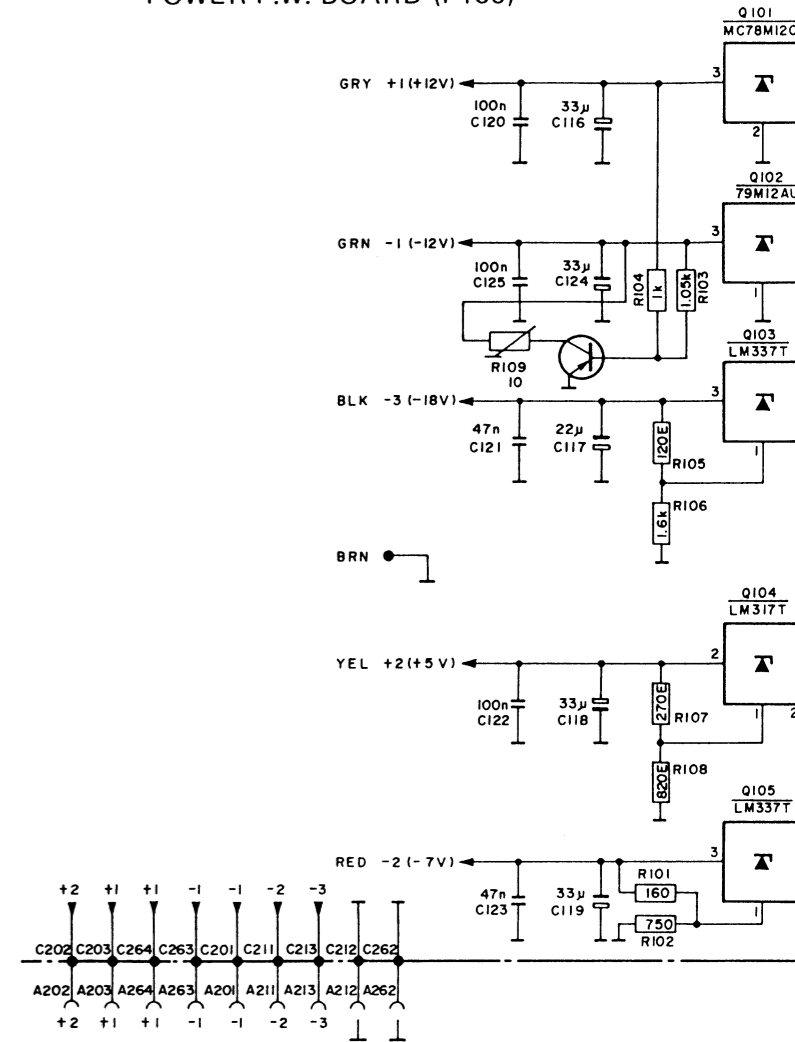

8.3 Power Supply (P100) Schematic Diagram and Component Locations

POWER P.W. BOARD (P100)

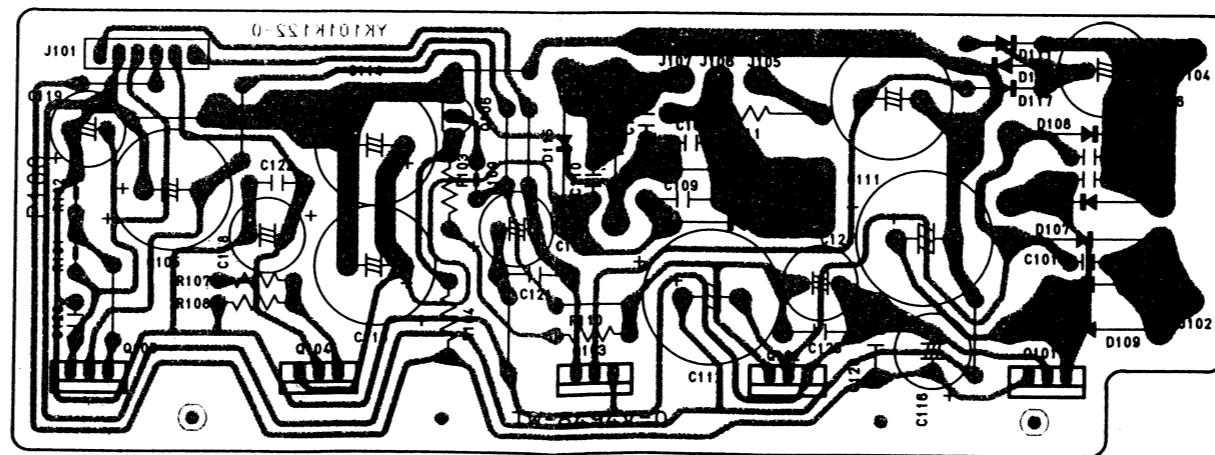
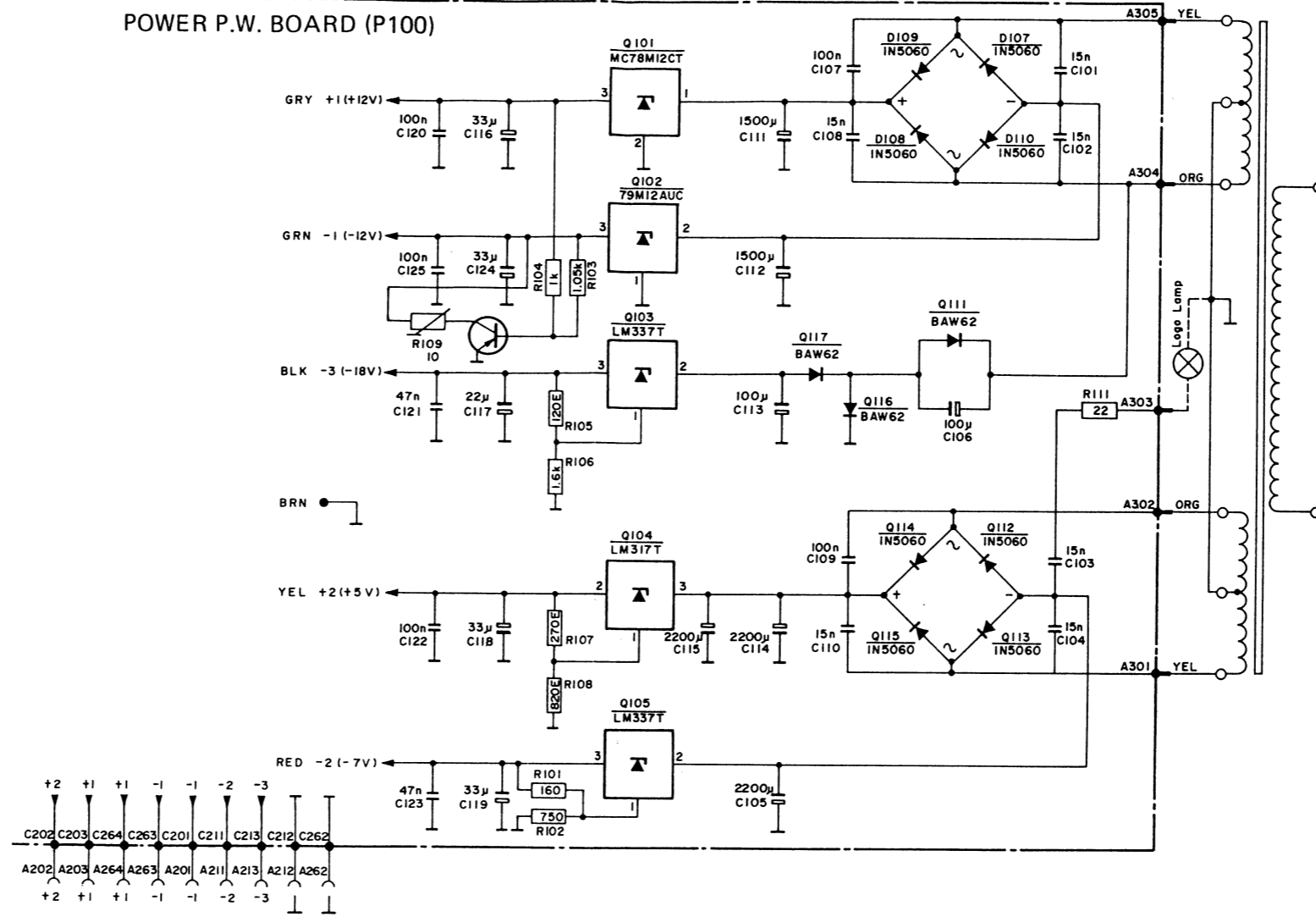

8.4 Pre Amp. + Laser (AY40) Schematic Diagram and Component Locations

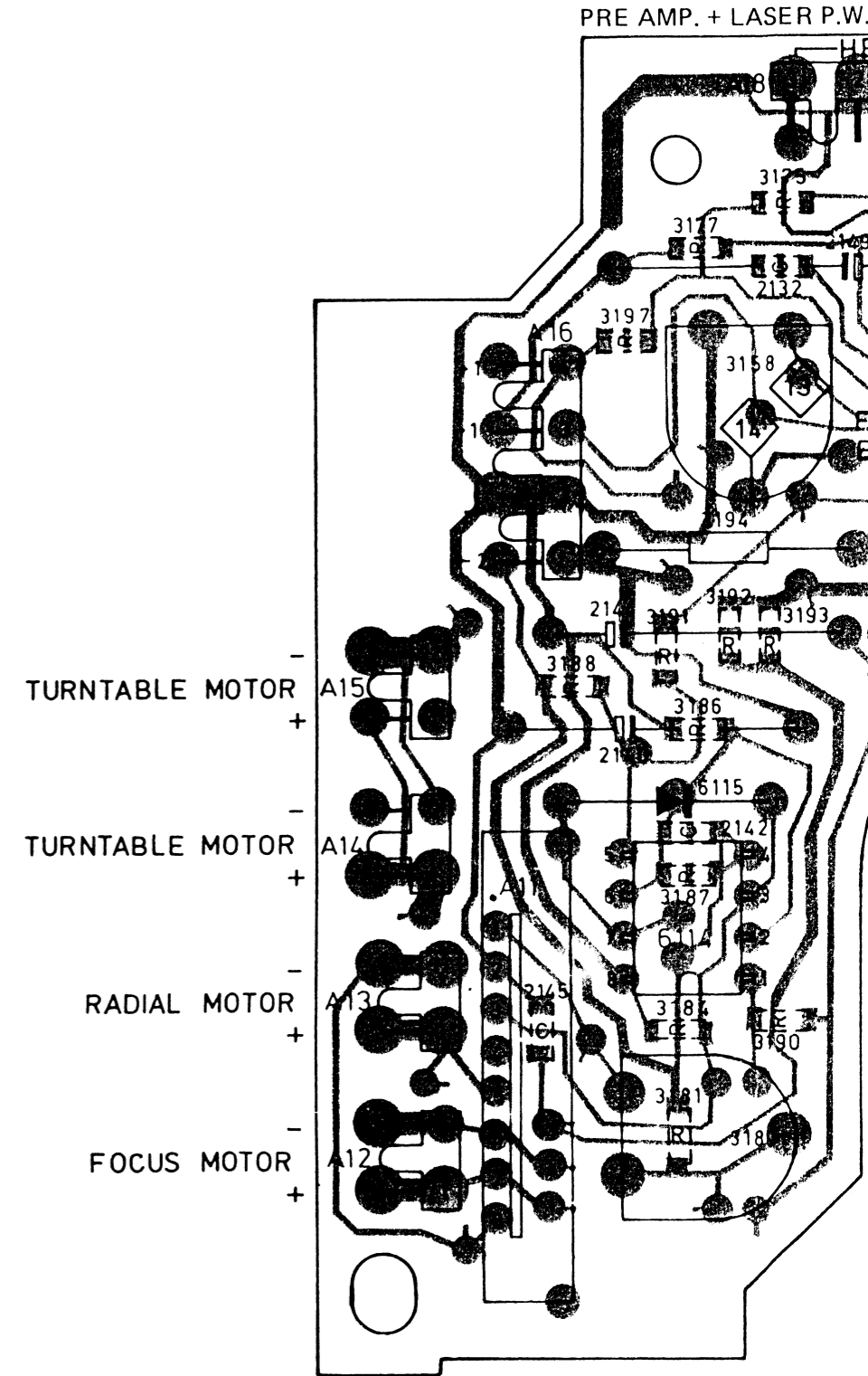
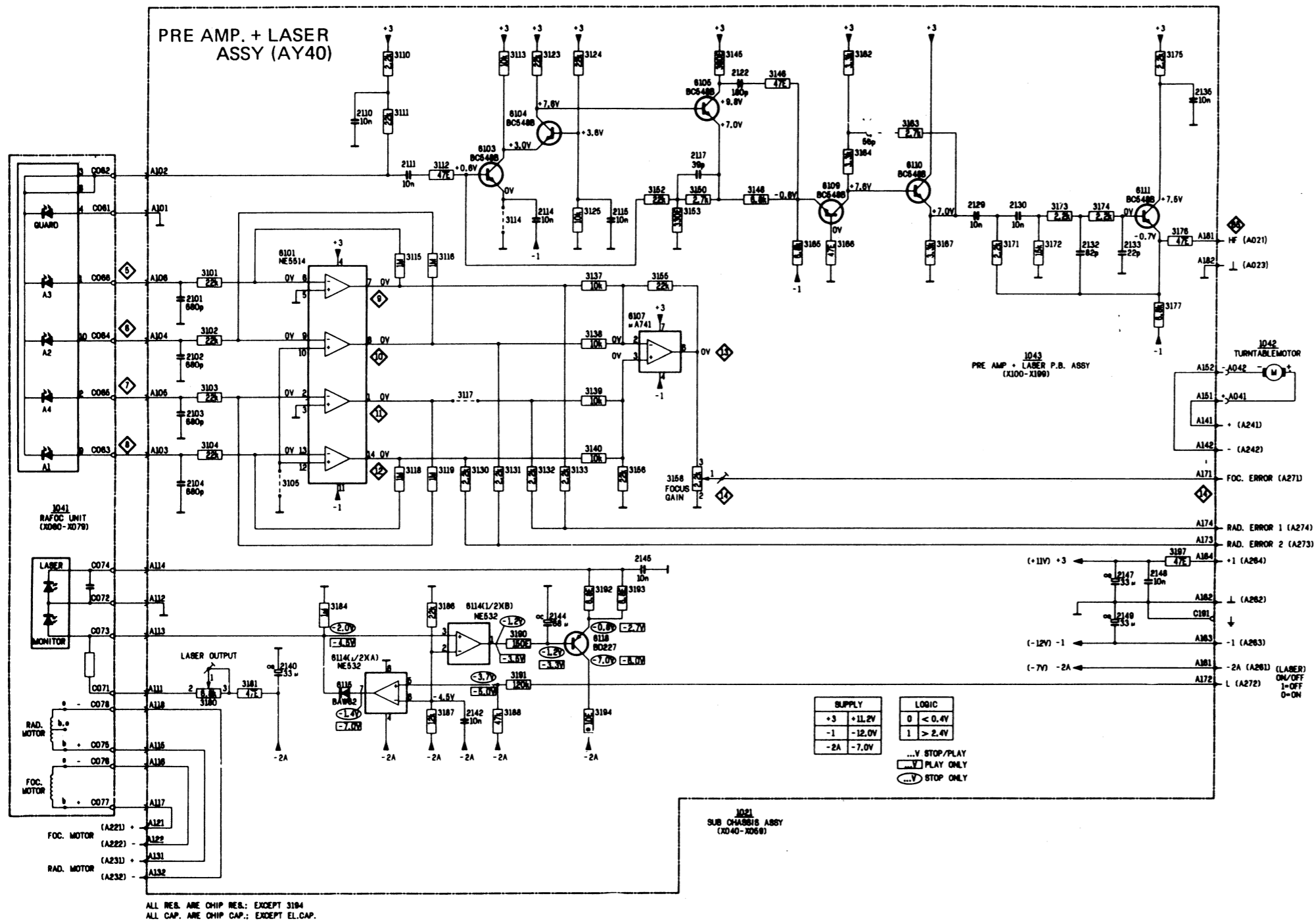

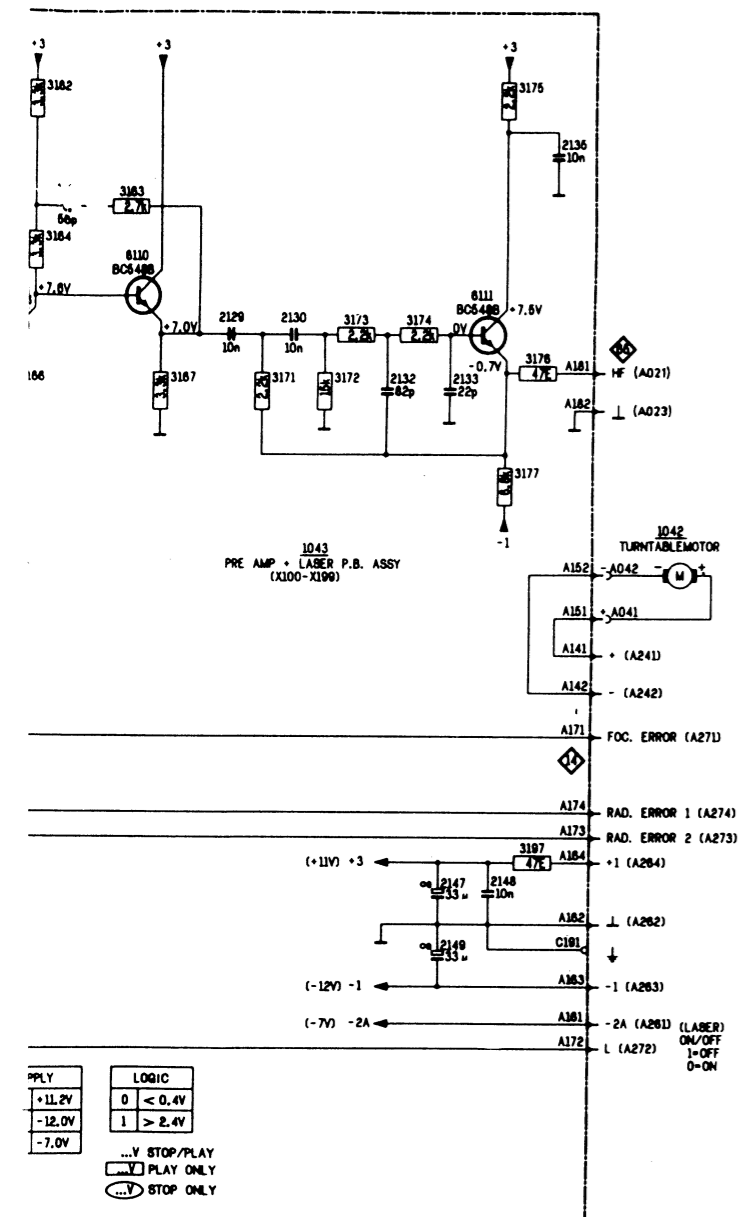

PRE AMP. + LASER P.W. BOARD

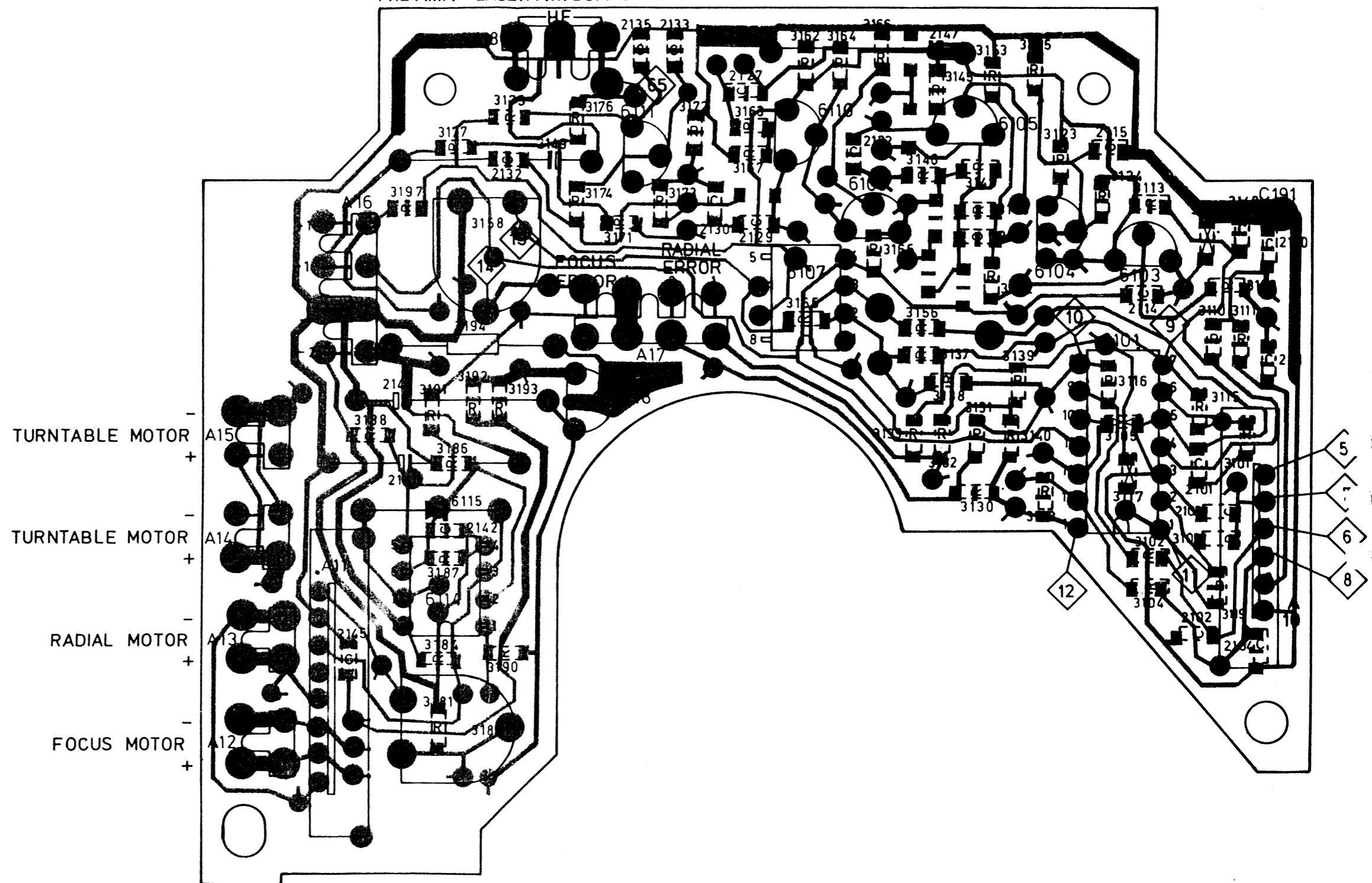

9. EXPLODED VIEW AND PARTS LIST

• [C01-99] Front Panel

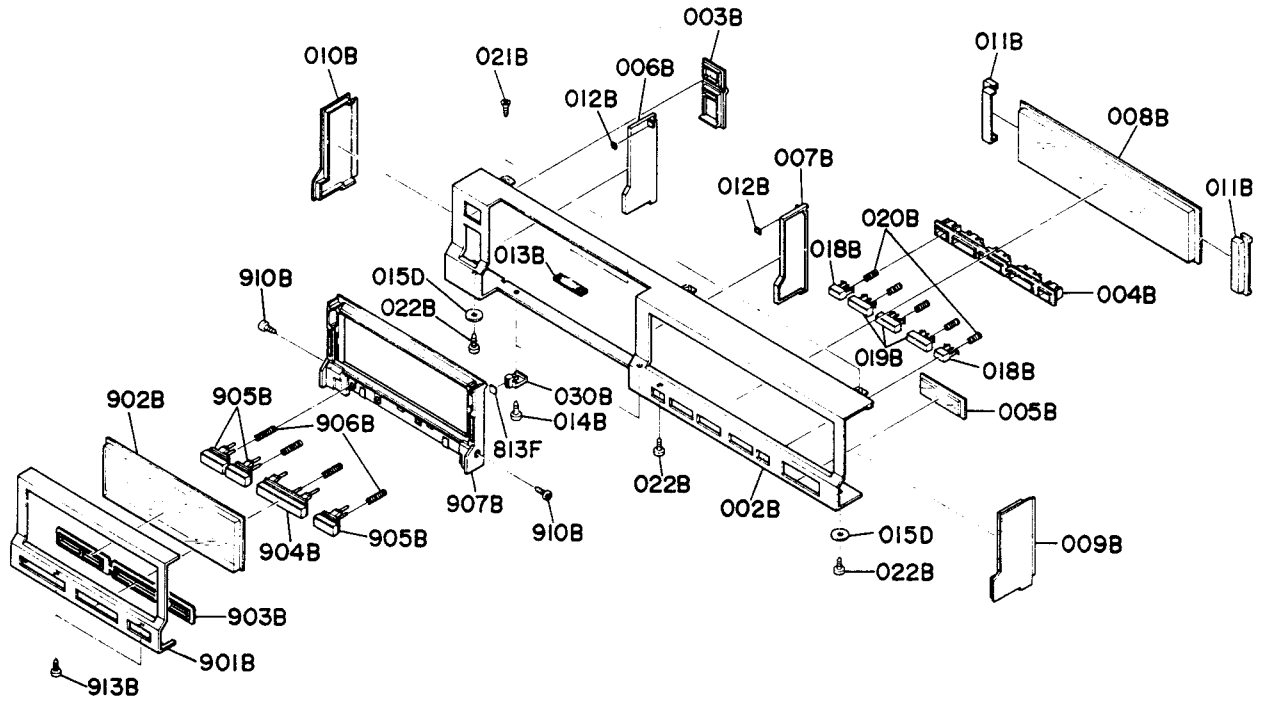

• (N): for Europe
• (F): for Japan

REF. DESIG.	Q'TY		PART NO.	DESCRIPTION
	N	F		
A	1	1	101K063400	Front Panel Assembly
002B	1	1	101K063010	Escutcheon, Front Panel
003B	1	1	101K259030	Bushing, Power
004B	1	1	101K259010	Bushing, Function
005B	1	1	101K251010	Badge
006B	1	1	101K201020	Divition, (L)
007B	1	1	101K201010	Divition, (R)
008B	1	1	101K158010	Window
009B	1	1	101K067010	Cap, (R)
010B	1	1	101K067020	Cap, (L)
011B	2	2	101K005010	Clamper
012B	2	2	101K056010	Buffer
013B	2	2	101K056030	Buffer

REF. DESIG.	Q'TY		PART NO.	DESCRIPTION
	N	F		
014B	2	2	51280308B0	B.H. Tapped Screw B3 x 8
018B	2	2	101K154010	Knob, Stop/Cancel
019B	3	3	101K154020	Knob
020B	5	5	101K115130	Spring, Knob
021B	2	2	51500306B0	F.H. Taptite Screw F3 x 6
022B	3	3	51280308B0	B.H. Tapped Screw B3 x 8
030B	2	2	101K114020	Stopper
901B	1	1	101K063020	Escutcheon, Door
902B	1	1	101K158030	Window, Door
903B	1	1	101K259060	Bushing
904B	1	1	101K154050	Knob, Play
905B	3	3	101K154060	Knob, FF/REV/Pause
906B	4	4	101K115130	Spring, Knob
907B	1	1	101K271040	Holder, Door
910B	2	2	51060305A9	P.H.M. Screw P3 x 5
913B	2	2	51280308B0	B.H. Tapped Screw B3 x 8
015D	2	2	54110149A0	Flat Washer, L
813F	2	2	101K056060	Buffer

● [C02-99] Lid (Top/Bottom)

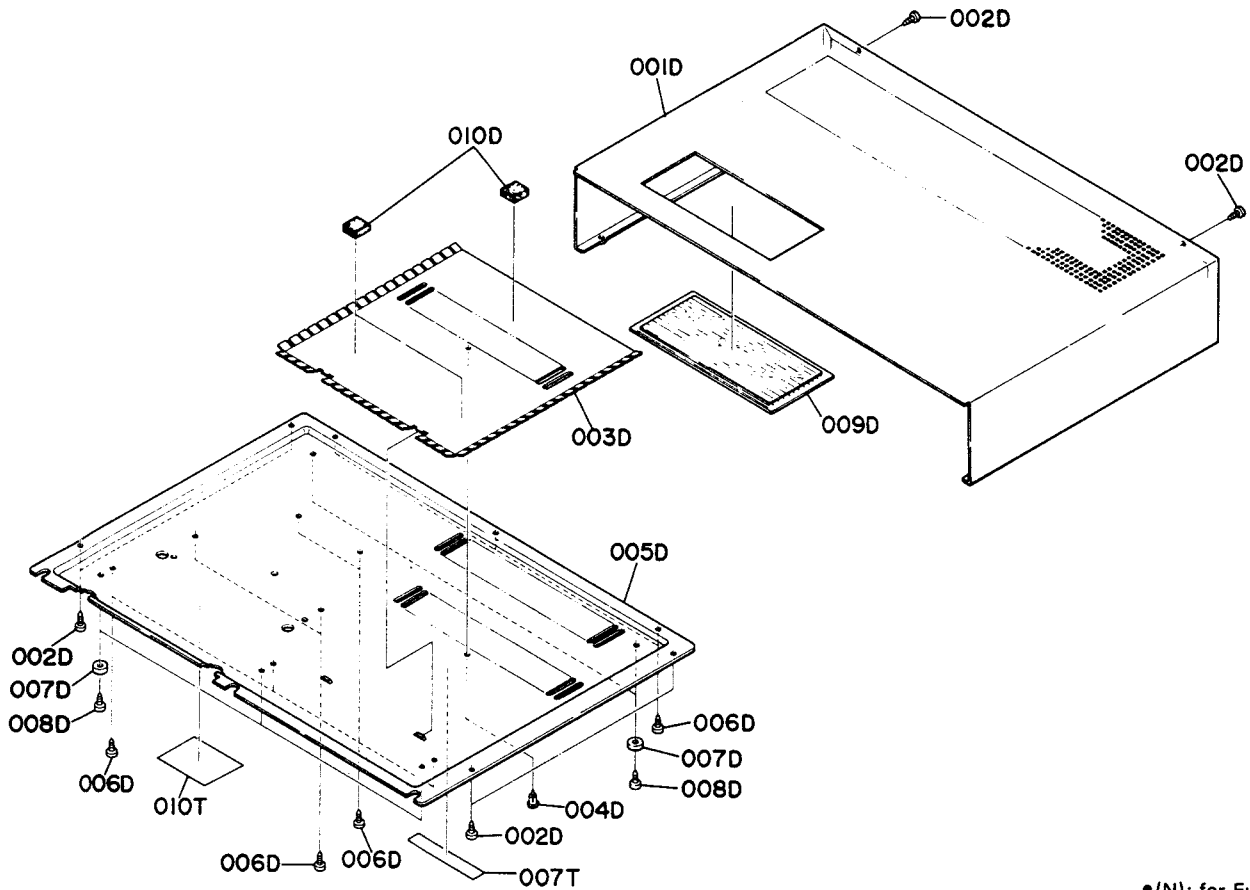

●(N): for Europe
●(F): for Japan

REF. DESIG.	Q'TY		PART NO.	DESCRIPTION
	N	F		
001D	1	1	101K257030	Lid, Top Cover
002D	6	6	51280305B0	B.H. Tapped Screw B3 x 5
003D	1	1	101K109030	Shield
004D	1	1	2912259020	Bushing
005D	1	1	101K257010	Lid, Bottom Cover
006D	10	10	51280305B0	B.H. Tapped Screw B3 x 5
007D	5	5	136T057010	Leg
008D	5	5	51280305B0	B.H. Tapped Screw B3 x 5
009D	1	1	101K158020	Window
010D	3	3	228H056010	Buffer

REF. DESIG.	Q'TY		PART NO.	DESCRIPTION
	N	F		
007T	1		2911861110	Label, Caution
010T		1	101K861030	Label, Laser Caution

• [C03-99] Rear Panel

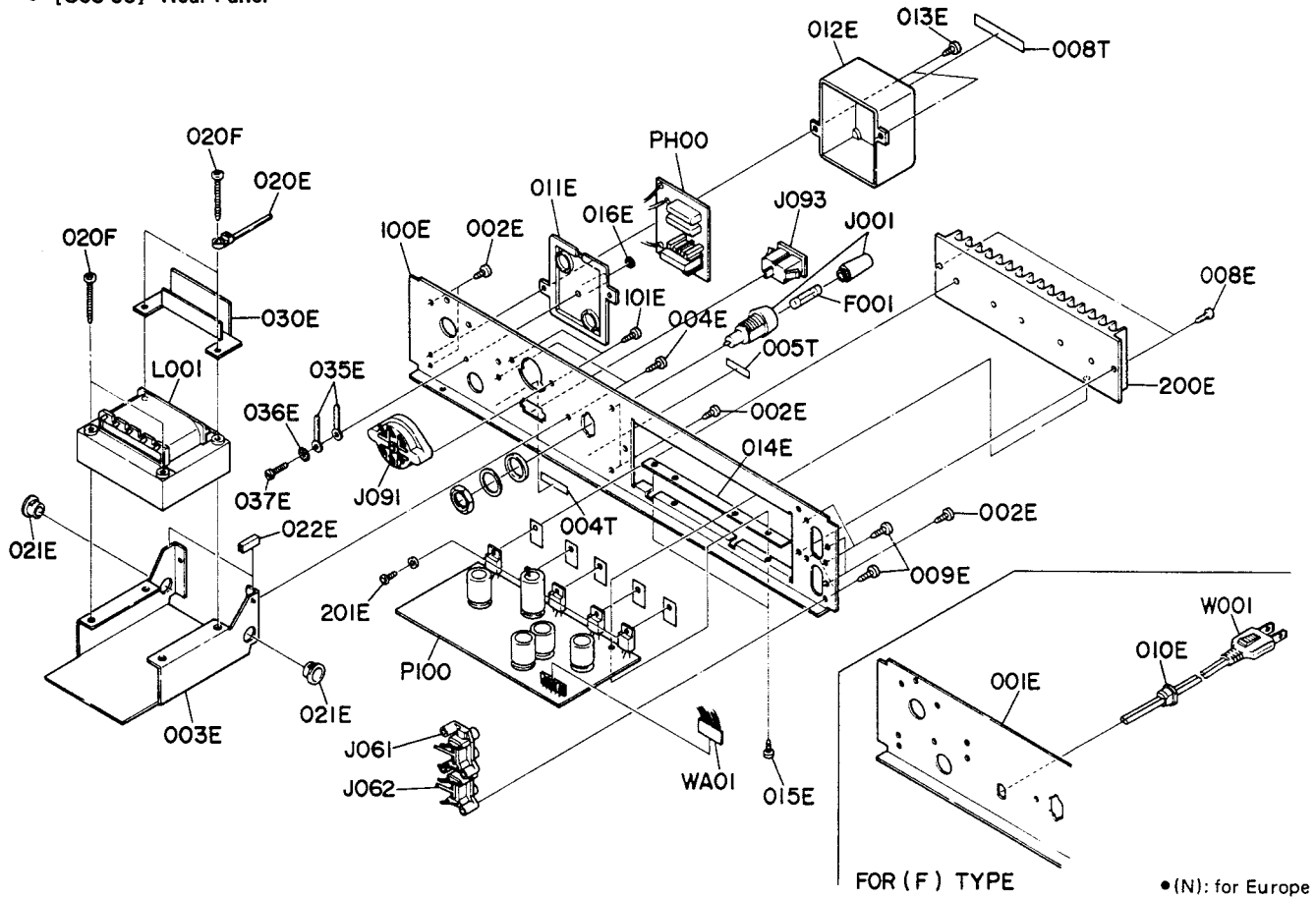

• (N): for Europe
• (F): for Japan

REF. DESIG.	Q'TY		PART NO.	DESCRIPTION
	N	F		
001E	1		101K053080	Cover, Rear Panel
002E	6	6	51280305U0	B.H. Tapped Screw B3 x 5
003E	1	1	101K160030	Bracket, Transformer
004E	2	2	51280305U0	B.H. Tapped Screw B3 x 5
008E	2	2	51280308U0	B.H. Tapped Screw B3 x 8
009E	4	4	51280308U0	B.H. Tapped Screw B3 x 8
010E	1		1455259030	Bushing, AC Cord
011E	1	1	101K064020	Case, Filter; Bottom
012E	1	1	101K064030	Case, Filter; Top
013E	2	2	51280310U0	B.H. Tapped Screw B3 x 10
014E	1	1	101K120030	Insulator
015E	2	2	51280310U0	B.H. Tapped Screw B3 x 10
016E	1	1	101K056020	Buffer
020E	2	2	101K005030	Clamper
021E	2	2	101K259080	Bushing
022E	2	2	101K259090	Bushing
030E	1		101K120040	Insulator
035E	2	2	4220005030	Clamper
036E	1	1	54050300R0	T.L. Washer, OR
037E	1	1	51280308B0	B.H. Tapped Screw B3 x 8
100E	1		101K053050	Cover, Rear Panel
101E	2		51280308U0	B.H. Tapped Screw B3 x 8
200E	1	1	101K267020	Heatsink
201E	5	5	51100308S9	B.H.M. Screw B3 x 8

REF. DESIG.	Q'TY		PART NO.	DESCRIPTION
	N	F		
020F	4	4	51280435U0	B.H. Tapped Screw B4 x 35
004T	1	1	2112265010	Indicator
005T	1		4581861010	Label
008T	1	1	2991861010	Label
△F001	1		FS10025800	Fuse 250mA 250V
△F001	1		FS10100600	Fuse 1A 250V
△J001	1		YJ08000290	Jack, Fuse Holder
△J001	1		YT08000300	Jack, Fuse Holder
J061	1	1	YT02020320	Terminal, RCA Pin (2P)
J062	1	1	YT02020370	Terminal, RCA Pin (2P)
△J091	1		BY05080030	Voltage Selector
△J093	1		YP04000580	Plug, AC Inlet
△L001	1		TS17627020	Power Transformer
△L001	1		TS17627010	Power Transformer
△W001	1		YC01800190	A.C. Power Cord
WA01	1	1	YB00070040	Connective Cord, (6P)

m 3598

• [P01-99] Front Chassis

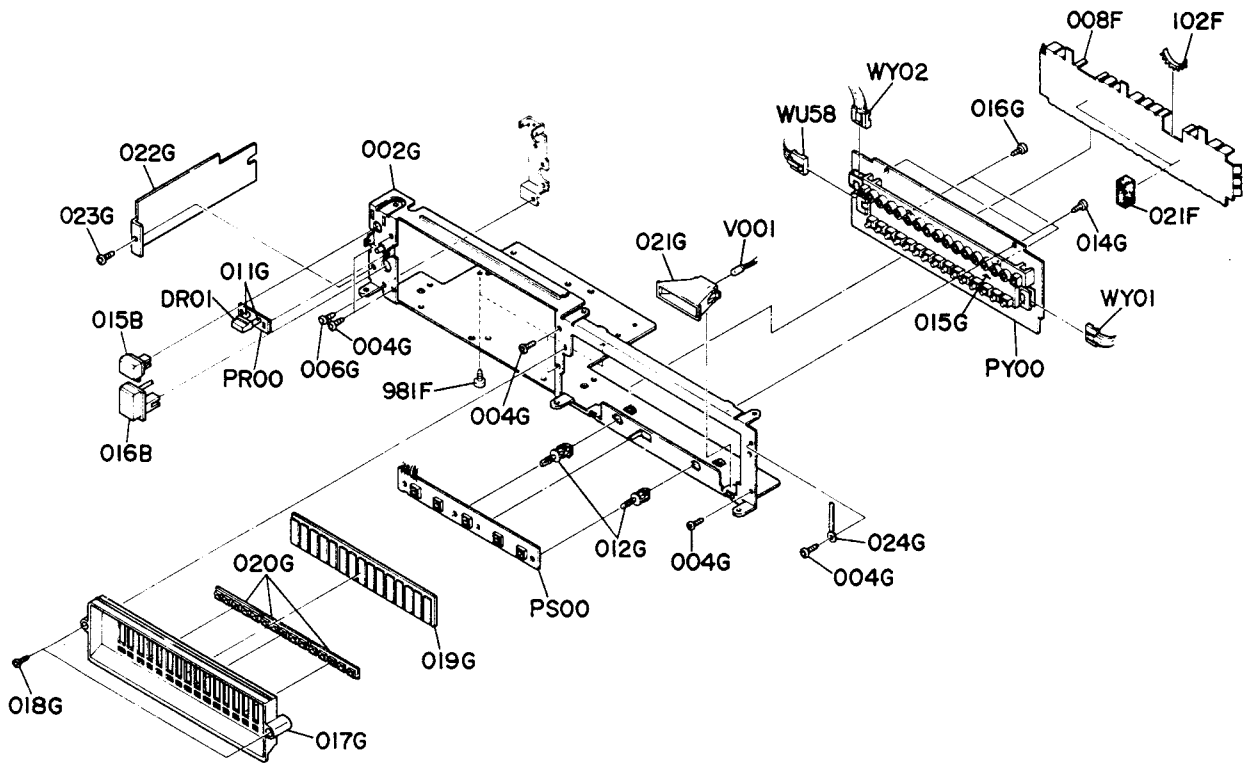

•(N): for Europe
•(F): for Japan

REF. DESIG.	Q'TY		PART NO.	DESCRIPTION
	N	F		
015B	1	1	101K154040	Knob, Open/Close
016B	1	1	101K154030	Knob, Power
008F	1	1	101K109040	Shield, Front
021F	2	2	2818056030	Buffer
102F	1	1	101K259110	Bushing
981F	2	2	51280305B0	B.H. Tapped Screw B3 x 5
002G	1	1	101K105010	Chassis, Front
004G	6	6	51280305B0	B.H. Tapped Screw B3 x 5
006G	1	1	51280305B0	B.H. Tapped Screw B3 x 5
011G	1	1	101K118020	Spacer
012G	2	2	3896101010	Support
014G	2	2	51280305B0	B.H. Tapped Screw B3 x 5
015G	1	1	101K271010	Holder, LED
016G	2	2	51500306B0	F.H. Tapped Screw F3 x 6
017G	1	1	101K280010	Housing, Display
018G	2	2	51280308B0	B.H. Tapped Screw B3 x 8

REF. DESIG.	Q'TY		PART NO.	DESCRIPTION
	N	F		
019G	1	1	101K265010	Indicator, Display
020G	3	3	101K265020	Indicator, Display
021G	1	1	101K274010	Reflector, Lamp
022G	1	1	101K120020	Insulator
023G	1	1	51280308B0	B.H. Tapped Screw B3 x 8
024G	1	1	4220005030	Clamper
V001	1	1	IN10080500	Lamp 60mA 8V
DR01	1	1	HI10032030	L.E.D. SLP171D
WU58	1	1	YB00250170	Connective Cord, (6P)
WY01	1	1	YB00240050	Connective Cord, (6P)
WY02	1	1	YB00150340	Connective Cord, (6P)

● [P03-99] Mecha Case and General Parts

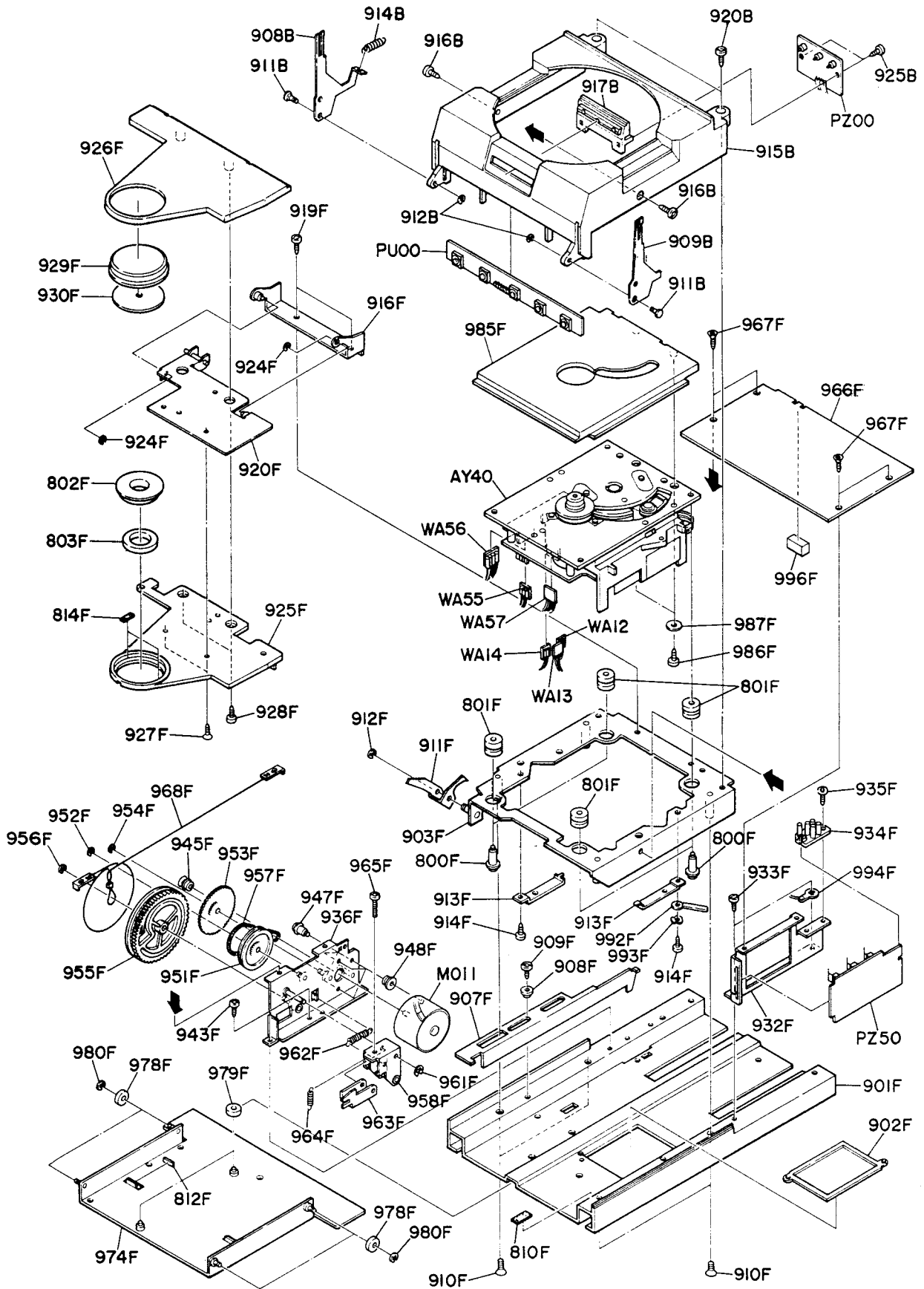

m 3600

•(N): for Europe
•(F): for Japan

REF. DESIG.	Q'TY		PART NO.	DESCRIPTION
	N	F		
908B	1	1	101K160120	Bracket, Door (L)
909B	1	1	101K160130	Bracket, Door (R)
911B	2	2	101K112120	Shaft, Door
912B	2	2	64000300R0	RG Ring, E Type
914B	1	1	101K115120	Spring
915B	1	1	101K064010	Case, Mecha
916B	2	2	51100308A9	B.H.M. Screw B3 x 8
917B	1	1	101K160020	Bracket, LED
920B	2	2	51280308B0	B.H. Tapped Screw B3 x 8
925B	2	2	51280308B0	B.H. Tapped Screw B3 x 8
800F	4	4	101K112170	Shaft
801F	4	4	101K259050	Bushing, Mecha
802F	1	1	101K353010	Ring
803F	1	1	101K252010	Pad
810F	1	1	101K056040	Buffer
812F	1	1	101K056050	Buffer
814F	2	2	101K056070	Buffer
901F	1	1	101K051020	Guide
902F	1	1	101K067040	Cap
903F	1	1	101K160420	Bracket Assembly, Mecha
907F	1	1	101K354020	Lever, Door Open
908F	1	1	101K055010	Collar
909F	1	1	51280308B0	B.H. Tapped Screw B3 x 8
910F	4	4	51040308A9	F.H.M. Screw F3 x 5
911F	1	1	101K002040	Arm, Door Open
912F	1	1	64000300R0	RG Ring, E Type
913F	2	2	101K104020	Retainer
914F	2	2	51280305B0	B.H. Tapped Screw B3 x 5
916F	1	1	101K104400	Retainer Assembly
919F	2	2	51280305B0	B.H. Tapped Screw B3 x 5
920F	1	1	101K160400	Bracket, Assembly
924F	2	2	64000300R0	RG Ring, E Type
925F	1	1	101K271030	Holder, Pressure Ring
926F	1	1	101K053070	Cover, Pressure Ring
927F	2	2	51040305A9	F.H.M. Screw F3 x 5
928F	2	2	51280308B0	B.H. Tapped Screw B3 x 8
929F	1	1	101K067030	Cap, Pressure Ring
930F	1	1	101K263020	Brake
932F	1	1	101K160110	Bracket
933F	2	2	51280308B0	B.H. Tapped Screw B3 x 8
934F	1	1	101K271050	Holder
935F	1	1	51280308B0	B.H. Tapped Screw B3 x 8
936F	1	1	101K160410	Bracket Assembly, Motor
943F	2	2	51280308B0	B.H. Tapped Screw B3 x 8
945F	1	1	101K262020	Pulley, Motor
947F	3	3	4367112150	Shaft, Motor
948F	3	3	313Y259010	Bushing
951F	1	1	101K262010	Pulley, Idler
952F	1	1	64001500R0	RG Ring, E Type
953F	1	1	101K058010	Gear, Idler
954F	1	1	64001500R0	RG Ring, E Type
955F	1	1	101K058030	Gear, Drive
956F	1	1	64000200R0	RG Ring, E Type
957F	1	1	101K264010	Belt, Drive
958F	1	1	101K002400	Arm, Drive Assembly

REF. DESIG.	Q'TY		PART NO.	DESCRIPTION
	N	F		
961F	1	1	64000300R0	RG Ring, E Type
962F	1	1	101K115090	Spring
963F	1	1	101K002030	Arm
964F	1	1	101K115070	Spring
965F	1	1	51100315A9	B.H.M. Screw B3 x 15
966F	1	1	101K257020	Lid, Mecha
967F	4	4	51500306B0	F.H. Taptite Screw F3 x 6
968F	1	1	101K125500	Joint, (K)
974F	1	1	101K051400	Guide Assembly, Rai.
978F	4	4	101K358010	Roller, B
979F	2	2	101K358020	Roller, A
980F	4	4	64000200R0	RG Ring, E Type
985F	1	1	101K053060	Cover, Mecha
986F	2	2	51380205A0	P.H. Tapped Screw P2 x 5
987F	2	2	54022601A0	Flat Washer, P.
992F	1	1	4220005020	Clamper
993F	1	1	54050300R0	T.L. Washer, OR
994F	1	1	62030039W0	Lug, Earth
996F	1	1	2818056030	Buffer
AY40	1	1	AY101K0040	Sub Chassis Assembly
M011	1	1	MM01500020	D.C. Motor, Drive
WA12	1	1	YB00209010	Connective Cord, (2P)
WA13	1	1	YB00219010	Connective Cord, (2P)
WA14	1	1	YB00229010	Connective Cord, (2P)
WA55	1	1	YB00279010	Connective Cord, (3P)
WA56	1	1	YB00259010	Connective Cord, (4P)
WA57	1	1	YB00279020	Connective Cord, (4P)
	1	1	QR11718120	Pre-Amp. + Laser P.W. Board Assembly

● [H01-99] Packing Materials

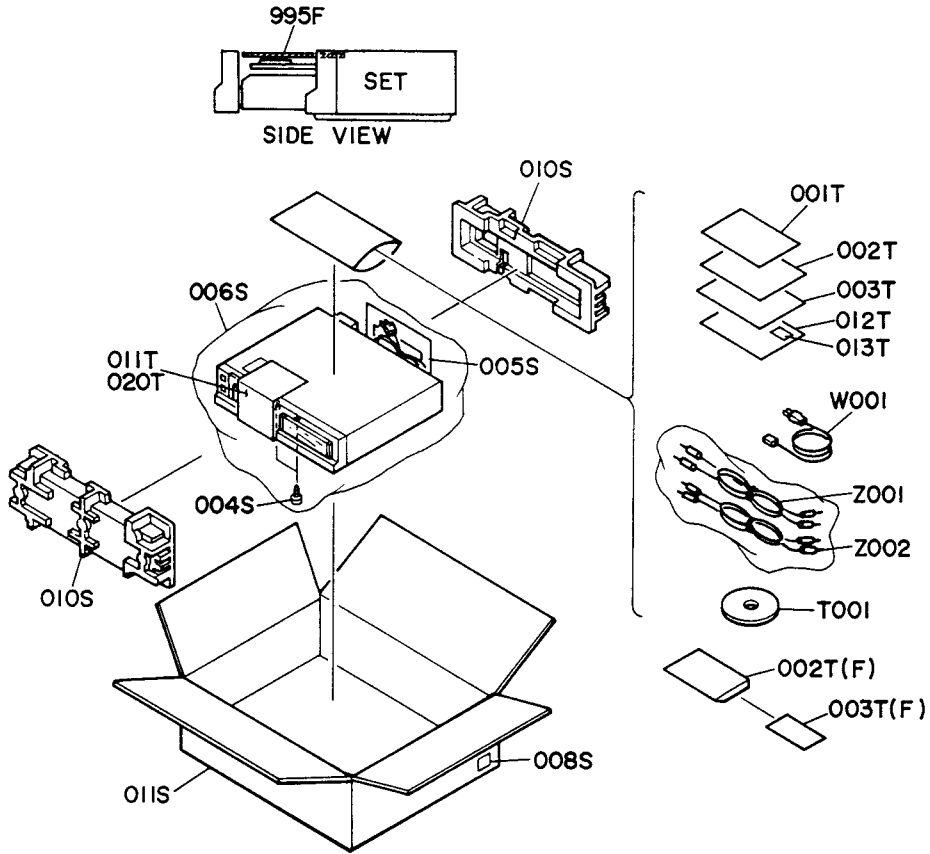

●(N): for Europe
●(F): for Japan

REF. DESIG.	Q'TY		PART NO.	DESCRIPTION
	N	F		
004S	2	2	51400350Y0	B.H. Tapped Screw B3 x 50
005S	1	1	2864804010	Steeve
006S	1	1	9090808030	Polyethylene Sheet
008S	4	4	9526019060	Serial No. Card
008S	4	4	9526019040	Serial No. Card
010S	1	1	101K809030	Cushion, Front/Rear
011S	1	1	101K801030	Packing Case
001T	1		101K851310	Instructions
001T	1	1	101K851110	Instructions
002T	1	1	101K851320	Instructions, Spec
002T	1	1	9631000130	Guarantee Card
003T	1	1	101K856010	Circuit Diagram
003T	1	1	128T854010	Guarantee Card
011T	1	1	101K861040	Label, Transportation
012T	1	1	9611000050	User's Card
013T	1	1	9540000010	License
020T	1	1	101K861050	Label, Transportation

REF. DESIG.	Q'TY		PART NO.	DESCRIPTION
	N	F		
T001	1	1	UD01200020	Disc, Demo
W001	1	1	ZC01805010	A.C. Power Cord
Z001	1	1	ZD01000240	Connective Cord, Audio Out
Z002	1	1	ZD01000220	Connective Cord, Remocon
995F	1	1	101K269010	Protector

10. ELECTRICAL PARTS LIST

•(N): for Europe
•(F): for Japan

REF. DESIG.	QTY		PART NO.	DESCRIPTION
	N	F		
P100	1	1	YK101K1220 ZZ101K8220	P100-POWER SUPPLY CIRCUIT BOARD P.W. Board, Power Supply P.W. Board Assembly
P100-CAPACITORS				
C101	1	1	DK18153300	Ceramic 0.015μF
C102	1	1	DK18153300	Ceramic 0.015μF
C103	1	1	DK18153300	Ceramic 0.015μF
C104	1	1	DK18153300	Ceramic 0.015μF
C105	1	1	EA22801630	Elect 2200μF 16V
C106	1	1	OA47702510	Elect 470μF 25V
C107	1	1	DF17104350	Film 0.1μF ±20%
C108	1	1	DK18153300	Ceramic 0.015μF
C109	1	1	DF17104350	Film 0.1μF ±20%
C110	1	1	DK18153300	Ceramic 0.015μF
C111	1	1	OA33802510	Elect 3300μF 25V
C112	1	1	OA33802510	Elect 3300μF 25V
C113	1	1	OA47702510	Elect 470μF 25V
C114	1	1	OA33801610	Elect 3300μF 16V
C115	1	1	OA33801610	Elect 3300μF 16V
C116	1	1	OA47601610	Elect 47μF 16V
C117	1	1	EA22602530	Elect 22μF 25V
C118	1	1	EA33601630	Elect 33μF 16V
C119	1	1	EA33601630	Elect 33μF 16V
C120	1	1	DF16104510	Film 0.1μF ±10%
C121	1	1	DF16104510	Film 0.1μF ±10%
C122	1	1	DF16104510	Film 0.1μF ±10%
C123	1	1	DK18473320	Ceramic 0.047μF
C124	1	1	OA47601610	Elect 47μF 16V
C125	1	1	DF16104510	Film 0.1μF ±10%
P100-RESISTORS (All Resistors are ±5% and ¼W)				
R101	1	1	GD05121140	120Ω
R102	1	1	GD05561140	560Ω
R103	1	1	GD05102140	1KΩ
R104	1	1	GD05102140	1KΩ
R107	1	1	GD05271140	270Ω
R108	1	1	GD05821140	820Ω
R109	1	1	HH00001490	Thermistor
R110	1	1	GD05470140	47Ω
R111	1	1	GA05220020	22Ω 2W
P100-SEMICONDUCTORS				
D107	1	1	HD20009290	Diode S2V20
D108	1	1	HD20009290	Diode S2V20
D109	1	1	HD20009290	Diode S2V20
D110	1	1	HD20009290	Diode S2V20
D111	1	1	HD20003210	Diode 1S2471
D112	1	1	HD20009290	Diode S2V20
D113	1	1	HD20009290	Diode S2V20
D114	1	1	HD20009290	Diode S2V20
D115	1	1	HD20009290	Diode S2V20
D116	1	1	HD20003210	Diode 1S2471
D117	1	1	HD20003210	Diode 1S2471
Q101	1	1	HC10043060	IC μPC7812H
Q102	1	1	HC10044060	IC μPC7912H
Q103	1	1	HC10079060	IC μPC7918H
Q104	1	1	HC10013360	IC LM317T
Q105	1	1	HC10014360	IC LM337T
Q106	1	1	HT106831D0	Transistor 2SA683(S)

REF. DESIG.	QTY		PART NO.	DESCRIPTION
	N	F		
J101	1	1	YP06002420	P100-MISCELLANEOUS Plug, (6P)
WA01	1	1	YB00070040	Connective Cord, (6P)
P200	1	1	YG101K0010 ZZ101K8010	P200-SERVO CIRCUIT BOARD P.W. Board, Servo P.W. Board Assembly
P200-CAPACITORS				
C201	1	1	DA17103010	Ceramic 0.01μF ±20%
C203	1	1	DA17103010	Ceramic 0.01μF ±20%
C204	1	1	DF15104350	Film 0.1μF ±5%
C205	1	1	DF74273010	Film 0.027μF ±2%
C207	1	1	EA33601630	Elect 33μF 16V
C208	1	1	DA17103010	Ceramic 0.01μF ±20%
C209	1	1	EA10505030	Elect 1μF 50V
C210	1	1	DD15270370	Ceramic 27pF ±5%
C211	1	1	DF15104350	Film 0.1μF ±5%
C212	1	1	DK16331300	Ceramic 330pF ±10%
C213	1	1	DD15270370	Ceramic 27pF ±5%
C214	1	1	EQ22601630	Elect 22μF 16V
C215	1	1	DF15154350	Film 0.15μF ±5%
C216	1	1	DA17103010	Ceramic 0.01μF ±20%
C217	1	1	EQ22601630	Elect 22μF 16V
C218	1	1	DF15103350	Film 0.01μF ±5%
C219	1	1	DF15473350	Film 0.047μF ±5%
C223	1	1	DA16331010	Ceramic 330pF ±10%
C224	1	1	DA16331010	Ceramic 330pF ±10%
C225	1	1	DK16331300	Ceramic 330pF ±10%
C228	1	1	DF15104350	Film 0.1μF ±5%
C227	1	1	DA16331010	Ceramic 330pF ±10%
C233	1	1	DF15474350	Film 0.47μF ±5%
C235	1	1	DA17103010	Ceramic 0.01μF ±20%
C236	1	1	DF74562010	Film 5600pF ±2%
C237	1	1	DF15333350	Film 0.033μF ±5%
C238	1	1	DF74562010	Film 5600pF ±2%
C239	1	1	DF55391090	Film 390pF ±5%
C241	1	1	EA33601630	Elect 33μF 16V
C242	1	1	EA33601630	Elect 33μF 16V
C243	1	1	DF15474350	Film 0.47μF ±5%
C244	1	1	DF55681090	Film 680pF ±5%
C246	1	1	DF74682010	Film 6800pF ±2%
C247	1	1	DF74682010	Film 6800pF ±2%
C250	1	1	EA33601630	Elect 33μF 16V
C251	1	1	DF15224350	Film 0.22μF ±5%
C256	1	1	DF74182010	Film 1800pF ±2%
C257	1	1	DF74682010	Film 6800pF ±2%
C259	1	1	DF15223350	Film 0.022μF ±5%
C261	1	1	DF74682010	Film 6800pF ±2%
C262	1	1	DF14682010	Film 6800pF ±2%
C265	1	1	EA33601630	Elect 33μF 16V
C266	1	1	EA33601630	Elect 33μF 16V
C267	1	1	DF15105350	Film 1μF ±5%

• (N): for Europe
• (F): for Japan

REF. DESIG.	Q'TY		PART NO.	DESCRIPTION
	N	F		
P200-RESISTORS (All Resistors are $\pm 5\%$ and $\frac{1}{4}W$)				
R201	1	1	GM21447520	47.5K Ω
R202	1	1	GM21410040	1M Ω
R203	1	1	GM21482530	825K Ω
R204	1	1	GD05105140	1M Ω
R205	1	1	GD05104140	100K Ω
R206	1	1	GD05474140	470K Ω
R209	1	1	GM21447520	47.5K Ω
R210	1	1	GD05104140	100K Ω
R211	1	1	GD05223140	22K Ω
R214	1	1	GD05223140	22K Ω
R215	1	1	GD05682140	6.8K Ω
R216	1	1	GD05104140	100K Ω
R217	1	1	GD05333140	33K Ω
R219	1	1	GM21422110	2.21K Ω
R220	1	1	GM21422110	2.21K Ω
R221	1	1	GD05682140	6.8K Ω
R222	1	1	GM21412120	12.1K Ω
R223	1	1	GM21410030	100K Ω
R227	1	1	GD05105140	1M Ω
R229	1	1	GD05472140	4.7K Ω
R230	1	1	GD05563140	56K Ω
R231	1	1	GD05334140	330K Ω
R233	1	1	GM21410030	100K Ω
R234	1	1	GD05472140	4.7K Ω
R235	1	1	GD05472140	4.7K Ω
R238	1	1	GD05474140	470K Ω
R239	1	1	GD05473140	47K Ω
R240	1	1	GD05033140	3.3 Ω
R242	1	1	GD05565140	5.6M Ω
R243	1	1	GD05565140	5.6M Ω
R244	1	1	GD05472140	4.7K Ω
R245	1	1	GD05154140	150K Ω
R246	1	1	GD05101140	100 Ω
R250	1	1	GD05683140	68K Ω
R251	1	1	GD05683140	68K Ω
R252	1	1	GD05681140	680 Ω
R253	1	1	GD05472140	4.7K Ω
R254	1	1	GD05104140	100K Ω
R255	1	1	GD05333140	33K Ω
R256	1	1	GA05220020	22 Ω 2W
R257	1	1	GD05223140	22K Ω
R258	1	1	GD05272140	2.7K Ω
R259	1	1	GD05682140	6.8K Ω
R260	1	1	GD05683140	68K Ω
R261	1	1	GD05683140	68K Ω
R262	1	1	GD05332140	3.3K Ω
R264	1	1	GD05332140	3.3K Ω
R265	1	1	GD05332140	3.3K Ω
R267	1	1	GD05222140	2.2K Ω
R268	1	1	GD05222140	2.2K Ω
R276	1	1	GD05472140	4.7K Ω
R279	1	1	GM21447520	47.5K Ω
R280	1	1	GM21447520	47.5K Ω
R281	1	1	GD05474140	470K Ω
R282	1	1	GM21447520	47.5K Ω
R283	1	1	GM21447520	47.5K Ω
R284	1	1	GD05103140	10K Ω
R285	1	1	GD05223140	22K Ω
R287	1	1	GM21468110	6.81K Ω
R288	1	1	GM21468110	6.81K Ω

REF. DESIG.	Q'TY		PART NO.	DESCRIPTION
	N	F		
R291	1	1	GD05473140	47K Ω
R292	1	1	GD05683140	68K Ω
R293	1	1	GD05471140	470 Ω
R294	1	1	GD05471140	470 Ω
R298	1	1	GM21447500	475 Ω
R299	1	1	GM21426710	2.67K Ω
R300	1	1	GM21410020	10K Ω
R301	1	1	GM21410020	10K Ω
R301	1	1	GD05222140	2.2K Ω
R304	1	1	GM21410020	10K Ω
R305	1	1	GM21410020	10K Ω
R306	1	1	GM21426710	2.67K Ω
R307	1	1	GD05222140	2.2K Ω
R308	1	1	GM21447500	475 Ω
R311	1	1	GM21482520	82.5K Ω
R312	1	1	GM21482520	82.5K Ω
R313	1	1	GD05472140	4.7K Ω
R315	1	1	RA01030070	10K Ω , Trimming
R316	1	1	GD05473140	47K Ω
R318	1	1	GD05821140	820 Ω
R319	1	1	GD05471140	470 Ω
R320	1	1	GD05152140	1.5K Ω
R323	1	1	GM21412130	121K Ω
R324	1	1	GM21475020	75K Ω
R325	1	1	GM21475020	75K Ω
R826	1	1	GM21422130	221K Ω
R327	1	1	GD05104140	100K Ω
R328	1	1	GM21433230	332K Ω
R335	1	1	GD05683140	68K Ω
R336	1	1	GD05472140	4.7K Ω
R340	1	1	GD05103140	10K Ω
R341	1	1	GD05103140	10K Ω
R342	1	1	GD05683140	68K Ω
R345	1	1	GD05473140	47K Ω
R346	1	1	GD05473140	47K Ω
R349	1	1	GD05183140	18K Ω
R350	1	1	GD05184140	180K Ω
R351	1	1	GD05333140	33K Ω
R352	1	1	GD05273140	27K Ω
R353	1	1	GD05472140	4.7K Ω
R356	1	1	GM21435620	35.6K Ω
R357	1	1	GM21439210	3.92K Ω
R358	1	1	GM21435630	356K Ω
R359	1	1	GD05272140	2.7K Ω
R360	1	1	GD05104140	100K Ω
R362	1	1	GD05104140	100K Ω
R363	1	1	GD05103140	10K Ω
R364	1	1	GD05472140	4.7K Ω
R365	1	1	GD05474140	470K Ω
R367	1	1	GD05474140	470K Ω
R370	1	1	GM21426320	26.3K Ω
R372	1	1	GD05473140	47K Ω
R373	1	1	GM21418230	182K Ω
R375	1	1	GD05473140	47K Ω
R376	1	1	GD05472140	4.7K Ω
R378	1	1	GD05273140	27K Ω
R379	1	1	GD05273140	27K Ω
R380	1	1	GD05332140	3.3K Ω
R381	1	1	GD05121140	120 Ω
R382	1	1	GD05121140	120 Ω

•(N): for Europe
•(F): for Japan

REF. DESIG.	Q'TY		PART NO.	DESCRIPTION
	N	F		
R384	1	1	HH00001490	Thermistor
R385	1	1	HH00001490	Thermistor
R386	1	1	GD05332140	3.3KΩ
R387	1	1	GD05022140	2.2Ω
R391	1	1	GM21456210	5.62KΩ
R392	1	1	GM21413020	13KΩ
R393	1	1	GD05223140	22KΩ
R394	1	1	GM21433230	332KΩ
R395	1	1	GD05223140	22KΩ
R396	1	1	GD05563140	56KΩ
R397	1	1	GD05563140	56KΩ
R398	1	1	GD05182140	1.8KΩ
R399	1	1	GD05152140	1.5KΩ
P200-SEMICONDUCTORS				
D244	1	1	HD20001000	Diode 1S2473
D245	1	1	HD20001000	Diode 1S2473
D246	1	1	HD20001000	Diode 1S2473
D249	1	1	HD20001000	Diode 1S2473
D250	1	1	HD20001000	Diode 1S2473
D251	1	1	HD30041010	Zener HZ2C2
D252	1	1	HD30004020	Zener MA1051
D255	1	1	HD20001000	Diode 1S2473
D256	1	1	HD20001000	Diode 1S2473
D257	1	1	HD20001000	Diode 1S2473
D258	1	1	HD20001000	Diode 1S2473
D259	1	1	HD20001000	Diode 1S2473
D261	1	1	HD20001000	Diode 1S2473
Q201	1	1	HC10027270	IC MAB8420
Q205	1	1	HC10081060	IC μPC339C
Q207	1	1	HC10055010	IC HD14025B
Q208	1	1	HC10080060	IC μPC1458C
Q209	1	1	HC10080060	IC μPC1458C
Q211	1	1	HC10056010	IC HD14053B
Q212	1	1	HC10082060	IC μPC324C
Q213	1	1	HC10057010	IC HD14070B
Q214	1	1	HC10082060	IC μPC324C
Q215	1	1	HC10082060	IC μPC324C
Q216	1	1	HC10020270	IC TCA240
Q217	1	1	HC10080060	IC μPC1458C
Q218	1	1	HC10083060	IC μPC741C
Q230	1	1	HT309452B0	Transistor 2SC945(Q)
Q231	1	1	HT328241Y0	Transistor 2SC2824(Y)
Q232	1	1	HT111841Y0	Transistor 2SA1184(Y)
Q233	1	1	HT313841R0	Transistor 2SC1384(R)
Q234	1	1	HT106841R0	Transistor 2SA684(R)
Q238	1	1	HT309452B0	Transistor 2SC945(Q)
Q239	1	1	HT309452B0	Transistor 2SC945(Q)
Q240	1	1	HT111841Y0	Transistor 2SA1184(Y)
Q241	1	1	HT328241Y0	Transistor 2SC2824(Y)
Q242	1	1	HT107332A0	Transistor 2SA733(Q)
P200-MISCELLANEOUS				
WA02	1	1	YB00180160	Connective Cord
WA03	1	1	YB00170060	Connective Cord
WA04	1	1	YB00170070	Connective Cord
WA05	1	1	YB00170080	Connective Cord
X201	1	1	XB108002L3	Crystal, 6MHz
250E	2	2	415H267010	Heatsink
251E	2	2	51280306B0	B.H. Tapped Screw B3 x 6

REF. DESIG.	Q'TY		PART NO.	DESCRIPTION
	N	F		
P500-DECODER CIRCUIT BOARD				
P500	1	1	YK101K1210	P.W. Board, Decoder
			ZZ101K8210	P.W. Board Assembly
P500-CAPACITORS				
C501	1	1	DF74223010	Film 0.022μF ±2%
C502	1	1	DF74223010	Film 0.022μF ±2%
C503	1	1	DK16222300	Ceramic 2200pF ±10%
C505	1	1	DF55272090	Film 2700pF ±5%
C506	1	1	DK16472300	Ceramic 4700pF ±10%
C508	1	1	DK16821300	Ceramic 820pF ±10%
C511	1	1	DK18223310	Ceramic 0.022μF
C512	1	1	DK18223310	Ceramic 0.022μF
C514	1	1	DF15104350	Film 0.1μF ±5%
C515	1	1	DF15104350	Film 0.1μF ±5%
C516	1	1	DK18103310	Ceramic 0.01μF
C520	1	1	DK16471300	Ceramic 470pF ±10%
C521	1	1	DK16471300	Ceramic 470pF ±10%
C523	1	1	DK18103310	Ceramic 0.01μF
C525	1	1	DK16222300	Ceramic 2200pF ±10%
C527	1	1	DF15104350	Film 0.1μF ±5%
C531	1	1	DK18104020	Ceramic 0.1μF
C533	1	1	EA10505030	Elect 1μF 50V
C534	1	1	DD15270370	Ceramic 27pF ±5%
C535	1	1	DD15270370	Ceramic 27pF ±5%
C537	1	1	DK18223310	Ceramic 0.022μF
C538	1	1	DK18223310	Ceramic 0.022μF
C539	1	1	DK18223310	Ceramic 0.022μF
C542	1	1	DD15680370	Ceramic 68pF ±5%
C543	1	1	DD15330370	Ceramic 33pF ±5%
C550	1	1	DK18223310	Ceramic 0.022μF
C551	1	1	DK18223310	Ceramic 0.022μF
C555	1	1	DK18223310	Ceramic 0.022μF
C556	1	1	DK18223310	Ceramic 0.022μF
C557	1	1	EA22602530	Elect 22μF 25V
C558	1	1	EA22602530	Elect 22μF 25V
C559	1	1	DK18223310	Ceramic 0.022μF
C560	1	1	DK18223310	Ceramic 0.022μF
C562	1	1	DK18223310	Ceramic 0.022μF
C563	1	1	EA22700630	Elect 220μF 6.3V
C564	1	1	DK16821300	Ceramic 820pF ±10%
C566	1	1	DF74512010	Film 5100pF ±2%
C567	1	1	DF74153010	Film 0.015μF ±2%
C568	1	1	DF74222010	Film 2200pF ±2%
C570	1	1	DF74222010	Film 2200pF ±2%
C571	1	1	DF74122010	Film 1200pF ±2%
C573	1	1	OA47601610	Elect 47μF 16V
C575	1	1	DD15101370	Ceramic 100pF ±5%
C580	1	1	DF15474350	Film 0.47μF ±5%
C581	1	1	DF15474350	Film 0.47μF ±5%
C582	1	1	DF15104350	Film 0.1μF ±5%
C583	1	1	DF15104350	Film 0.1μF ±5%
C584	1	1	DF15104350	Film 0.1μF ±5%
C585	1	1	DK18223310	Ceramic 0.022μF
C586	1	1	DK18223310	Ceramic 0.022μF

•(N): for Europe
•(F): for Japan

REF. DESIG.	Q'TY		PART NO.	DESCRIPTION
	N	F		
C587	1	1	DK18223310	Ceramic 0.022μF
C588	1	1	DK18223310	Ceramic 0.022μF
C589	1	1	DK18223310	Ceramic 0.022μF
C590	1	1	DF16104510	Film 0.1μF ±10%
C591	1	1	DK16152300	Ceramic 1500pF ±10%
C593	1	1	EA22602530	Elect 22μF 25V
C594	1	1	DK18223310	Ceramic 0.022μF
C595	1	1	DK18223310	Ceramic 0.022μF
C597	1	1	DK18223310	Ceramic 0.022μF
C599	1	1	DK16321300	Ceramic 820pF ±10%
C601	1	1	DF74512010	Film 5100pF ±2%
C602	1	1	DF74153010	Film 0.015μF ±2%
C603	1	1	DF74222010	Film 2200pF ±2%
C605	1	1	DF74222010	Film 2200pF ±2%
C606	1	1	DF74122010	Film 1200pF ±2%
C608	1	1	OA47601610	Elect 47μF 16V
C609	1	1	DF16104510	Film 0.1μF ±10%
C610	1	1	DD15101370	Ceramic 100pF ±5%
C615	1	1	EA22602530	Elect 22μF 25V
C617	1	1	DF16104510	Film 0.1μF ±10%
C618	1	1	DF16104510	Film 0.1μF ±10%
C619	1	1	DF16104510	Film 0.1μF ±10%
C621	1	1	EA22602530	Elect 22μF 25V
C623	1	1	DK18223310	Ceramic 0.022μF
C624	1	1	EA22602530	Elect 22μF 25V
C626	1	1	EA22602530	Elect 22μF 25V
C628	1	1	EA22602530	Elect 22μF 25V
C630	1	1	DF15474350	Film 0.47μF ±5%
C631	1	1	DF15474350	Film 0.47μF ±5%
C632	1	1	DF15104350	Film 0.1μF ±5%
C633	1	1	DF15104350	Film 0.1μF ±5%
C634	1	1	DF15104350	Film 0.1μF ±5%
C635	1	1	DK18223310	Ceramic 0.022μF
C636	1	1	DK18223310	Ceramic 0.022μF
C637	1	1	DK18223310	Ceramic 0.022μF
C638	1	1	DK18223310	Ceramic 0.022μF
C639	1	1	DK18223310	Ceramic 0.022μF
C641	1	1	DK16152300	Ceramic 1500pF ±10%
P500-RESISTORS (All Resistors are ±5% and ¼W)				
R501	1	1	GD05825140	8.2MΩ
R502	1	1	GD05824140	820KΩ
R503	1	1	GM21417820	17.8KΩ
R504	1	1	GD05824140	820KΩ
R505	1	1	GM21417830	178KΩ
R506	1	1	GD05681140	680Ω
R507	1	1	GM21417820	17.8KΩ
R508	1	1	GD05825140	8.2MΩ
R510	1	1	GM21439210	3.92KΩ
R511	1	1	GM21410020	10KΩ
R512	1	1	GM21410030	100KΩ
R513	1	1	GM21410030	100KΩ
R514	1	1	GD05105140	1MΩ
R515	1	1	GD05010140	1Ω
R516	1	1	GD05105140	1MΩ
R519	1	1	GD05222140	2.2KΩ
R520	1	1	GD05223140	22KΩ
R521	1	1	GD05103140	10KΩ
R523	1	1	GD05222140	2.2KΩ
R525	1	1	GD05222140	2.2KΩ

REF. DESIG.	Q'TY		PART NO.	DESCRIPTION
	N	F		
R527	1	1	GD05391140	390Ω
R529	1	1	GD05223140	22KΩ
R530	1	1	GD05103140	10KΩ
R532	1	1	GD05332140	3.3KΩ
R534	1	1	GD05103140	10KΩ
R535	1	1	GD05104140	100KΩ
R536	1	1	GD05104140	100KΩ
R537	1	1	GD05274140	270KΩ
R538	1	1	GD05393140	39KΩ
R539	1	1	GD05010140	1Ω
R540	1	1	GD05472140	4.7KΩ
R541	1	1	GD05472140	4.7KΩ
R542	1	1	GD05473140	47KΩ
R543	1	1	GD05104140	100KΩ
R544	1	1	GD05472140	4.7KΩ
R545	1	1	GD05105140	1MΩ
R547	1	1	GD05472140	4.7KΩ
R548	1	1	GD05332140	3.3KΩ
R549	1	1	GD05472140	4.7KΩ
R550	1	1	GD05822140	8.2KΩ
R555	1	1	GD05102140	1KΩ
R558	1	1	GD05105140	1MΩ
R560	1	1	GD05102140	1KΩ
R563	1	1	GD05562140	5.6KΩ
R564	1	1	GD05102140	1KΩ
R565	1	1	GD05102140	1KΩ
R566	1	1	GD05102140	1KΩ
R567	1	1	GD05102140	1KΩ
R569	1	1	GM21410000	100Ω
R570	1	1	GM21426710	2.67KΩ
R571	1	1	GM21410000	100Ω
R572	1	1	GM21410010	1KΩ
R573	1	1	GD05105140	1MΩ
R574	1	1	GM21428210	1.82KΩ
R576	1	1	GM21422110	2.21KΩ
R577	1	1	GM21422110	2.21KΩ
R579	1	1	GM21410020	10KΩ
R580	1	1	GM21410030	100KΩ
R581	1	1	GD05470140	47Ω
R584	1	1	GM214825G0	82.5Ω
R585	1	1	GM21456200	562Ω
R586	1	1	RA05010050	500Ω, Trimming
R587	1	1	GM21426700	267Ω
R590	1	1	GM21410000	100Ω
R591	1	1	GM21426710	2.67KΩ
R592	1	1	GM21410000	100Ω
R593	1	1	GM21410010	1KΩ
R594	1	1	GD05105140	1MΩ
R595	1	1	GM21418210	1.82KΩ
R597	1	1	GM21422110	2.21KΩ
R598	1	1	GM21422110	2.21KΩ
R600	1	1	GM21410020	10KΩ
R601	1	1	GM21410030	100KΩ
R602	1	1	GD05470140	47Ω
R605	1	1	GM214825G0	82.5Ω
R606	1	1	GM21461900	619Ω
R607	1	1	GD05151140	150Ω
R608	1	1	GD05471140	470Ω

m 3606

•(N): for Europe
•(F): for Japan

REF. DESIG.	QTY		PART NO.	DESCRIPTION
	N	F		
P500-SEMICONDUCTOR:				
D539	1	1	HD40004030	Varicap SVC303-GR
D540	1	1	HD40004030	Varicap SVC303Y-GR
D541	1	1	HD30004020	Zener MA1051
D544	1	1	HD20001210	Diode 1S2473C
D545	1	1	HD20001210	Diode 1S2473C
D546	1	1	HD20001210	Diode 1S2473C
D548	1	1	HD20001210	Diode 1S2473C
D549	1	1	HD20001210	Diode 1S2473C
D550	1	1	HD20001210	Diode 1S2473C
D551	1	1	HD20001210	Diode 1S2473C
D555	1	1	HD20001210	Diode 1S2473C
D556	1	1	HD20001210	Diode 1S2473C
D557	1	1	HD20001210	Diode 1S2473C
D558	1	1	HD20001210	Diode 1S2473C
D559	1	1	HD20001210	Diode 1S2473C
Q501	1	1	HC10022270	IC SAA7010(M4290A)
Q504	1	1	HC10058010	IC HD74LS74
Q506	1	1	HC10026270	IC MAB8410
Q508	1	1	HC10084060	IC μ PC393C
Q510	1	1	HC10023270	IC SAA7020(M4280)
Q512	1	1	HC10059010	IC HM6116P-4
Q514	1	1	HC10021270	IC SAA7000(M4300)
Q517	1	1	HC10024270	IC SAA7030(M4550)
Q519	1	1	HC10025270	IC TDA1540D
Q520	1	1	HC10025270	IC TDA1540D
Q523	1	1	HC10023090	IC NJM5532
Q525	1	1	HC10023090	IC NJM5532
Q530	1	1	HT309452B0	Transistor 2SC945(Q or P)
Q531	1	1	HT309452B0	Transistor 2SC945(Q or P)
Q533	1	1	HT309452B0	Transistor 2SC945(Q or P)
Q535	1	1	HT107332A0	Transistor 2SA733(Q or P)
Q536	1	1	HT107332A0	Transistor 2SA733(Q or P)
P500-MISCELLANEOUS				
J510	1	1	YP10001990	Plug, (3P)
J520	1	1	YP10002010	Plug, (5P)
J540	1	1	YP10001990	Plug, (3P)
J550	1	1	YP10001990	Plug, (3P)
L501	1	1	LO71020020	OSC Coil
L507	1	1	LY10050040	Relay
L508	1	1	LY10050040	Relay
L510	1	1	LY10050040	Relay
L511	1	1	LY10050040	Relay
X501	1	1	XB108001L3	Crystal, 4.4336MHz
X504	1	1	XB108002L2	Crystal, 4.2336MHz

REF. DESIG.	QTY		PART NO.	DESCRIPTION
	N	F		
P800-MOTOR/REMOCON CIRCUIT BOARD				
P800	1	1	YK101K1710	P.W. Board, Motor/Remocon
			ZZ101K8710	P.W. Board Assembly
P800-CAPACITORS				
C801	1	1	EA22601630	Elect 22 μ F 16V
C802	1	1	EA10505030	Elect 1 μ F 50V
C803	1	1	DK18103300	Ceramic 0.01 μ F
C804	1	1	EA10701030	Elect 100 μ F 10V
C805	1	1	EA47601030	Elect 47 μ F 10V
C806	1	1	DK18103300	Ceramic 0.01 μ F
C807	1	1	EA10701030	Elect 100 μ F 10V
C808	1	1	EQ10505030	Elect 1 μ F 50V
C851	1	1	EA22602530	Elect 22 μ F 25V
C852	1	1	EA10701030	Elect 100 μ F 10V
C853	1	1	DK18103300	Ceramic 0.01 μ F
C854	1	1	DK16221300	Ceramic 220pF \pm 10%
C855	1	1	DK16221300	Ceramic 220pF \pm 10%
C856	1	1	EA10505030	Elect 1 μ F 50V
C857	1	1	DK18103300	Ceramic 0.01 μ F
C858	1	1	EA22601630	Elect 22 μ F 16V
C589	1	1	OA47601610	Elect 47 μ F 16V
\pm G801	1		DK18103840	Ceramic 0.01 μ F, Spark Killer
\pm G801	1	1	DK18103850	Ceramic 0.01 μ F, Spark Killer
P800-RESISTORS (All Resistors are \pm 5% and $\frac{1}{2}$ W)				
R801	1	1	GD05392140	3.9K Ω
R802	1	1	GD05103140	10K Ω
R803	1	1	GD05103140	10K Ω
R804	1	1	GA05181010	180 Ω 1W
R805	1	1	GD05562140	5.6K Ω
R806	1	1	GD05472140	4.7K Ω
R807	1	1	GD05223140	22K Ω
R808	1	1	GD05223140	22K Ω
R809	1	1	GD05103140	10K Ω
R810	1	1	GD05682140	6.8K Ω
R811	1	1	GD05682140	6.8K Ω
R812	1	1	GD05103140	10K Ω
R813	1	1	GD05103140	10K Ω
R814	1	1	GD05332140	3.3K Ω
R815	1	1	GD05333140	33K Ω
R816	1	1	GD05472140	4.7K Ω
R817	1	1	GD05392140	3.9K Ω
R818	1	1	GD05332140	3.3K Ω
R819	1	1	GD05103140	10K Ω
R820	1	1	GG05082120	8.2 Ω $\frac{1}{2}$ W
R821	1	1	GD05103140	10K Ω
R822	1	1	GD05222140	2.2K Ω
R823	1	1	GD05821140	820 Ω
R824	1	1	GD05472140	4.7K Ω
R825	1	1	GA05330020	33 Ω 2W
R826	1	1	GG05122120	1.2K Ω $\frac{1}{2}$ W
R827	1	1	GG05122120	1.2K Ω $\frac{1}{2}$ W

• (N): for Europe
• (F): for Japan

REF. DESIG.	Q'TY		PART NO.	DESCRIPTION	
	N	F			
ΔR851	1	1	GA05820010	82Ω	1W
R852	1	1	GD05473140	47KΩ	
R853	1	1	GD05105140	1MΩ	
R854	1	1	GD05103140	10KΩ	
R855	1	1	GD05103140	10KΩ	
R856	1	1	GD05103140	10KΩ	
R857	1	1	GD05103140	10KΩ	
R862	1	1	GD05473140	47KΩ	
R863	1	1	GD05103140	10KΩ	
R864	1	1	GD05104140	100KΩ	
R865	1	1	GD05473140	47KΩ	
R866	1	1	GD05103140	10KΩ	
R867	1	1	GD05103140	10KΩ	
R868	1	1	GD05153140	15KΩ	
P800-SEMICONDUCTORS					
D801	1	1	HD20011050	Diode	1S1555
D802	1	1	HD30052090	Zener	WZ056
D803	1	1	HD30091090	Zener	BZ081
D804	1	1	HD20011050	Diode	1S1555
D805	1	1	HD20011050	Diode	1S1555
D806	1	1	HD20011050	Diode	1S1555
D807	1	1	HD20011050	Diode	1S1555
D808	1	1	HD20011050	Diode	1S1555
D809	1	1	HI10016050	L.E.D.	TLUG-143
D810	1	1	HI10016050	L.E.D.	TLUG-143
D811	1	1	HI10016050	L.E.D.	TLUG-143
D851	1	1	HD20011050	Diode	1S1555
Q801	1	1	HT805471B0	Transistor	BC547B
Q802	1	1	HT805471B0	Transistor	BC547B
Q803	1	1	HT805471B0	Transistor	BC547B
Q804	1	1	HT805471B0	Transistor	BC547B
Q805	1	1	HT805471B0	Transistor	BC547B
Q806	1	1	HT605571B0	Transistor	BC557B
Q807	1	1	HT313841R0	Transistor	2SC1384(R)
Q808	1	1	HT313841R0	Transistor	2SC1384(R)
Q809	1	1	HT805471B0	Transistor	BC547B
Q851	1	1	HC10102030	IC	LM6416E
Q852	1	1	HT805471B0	Transistor	BC547(B)
Q853	1	1	HT805471B0	Transistor	BC547(B)
Q854	1	1	HT805471B0	Transistor	BC547(B)
Q855	1	1	HT805471B0	Transistor	BC547(B)
Q856	1	1	HT805471B0	Transistor	BC547(B)
Q857	1	1	HT804571B0	Transistor	BC547(B)
Q858	1	1	HT605571B0	Transistor	BC557(B)
Q859	1	1	HC10031060	IC	MPC78L05
P800-MISCELLANEOUS					
J801	1	1	YP10001200	Plug	
J802	1	1	YP10001200	Plug	
J851	1	1	YP06003000	Plug	
J852	1	1	YP06003000	Plug	
J853	1	1	YP06003020	Plug	
J854	1	1	YP06003030	Plug	
J855	1	1	YP06003010	Plug	
L801	1	1	LC14730040	Choke Coil, 47μH	
L802	1	1	LC14730040	Choke Coil, 47μH	

REF. DESIG.	Q'TY		PART NO.	DESCRIPTION	
	N	F			
ΔS801	1		SP01010600	Push Switch, Power	
ΔS801	1	1	SP01010620	Push Switch, Power	
S802	1	1	SP04010430	Push Switch, ON/OFF	
S803	1	1	SS01020370	Slide Switch, Service	
S804	1	1	SM01010980	Mini Switch, Safety	
W851	1	1	YB00150360	Connective Cord, (2P)	
W852	1	1	YB00500310	Connective Cord, (2P)	
W853	1	1	YB00700180	Connective Cord, (4P)	
W854	1	1	YB00650030	Connective Cord, (5P)	
W855	1	1	YB00580010	Connective Cord, (3P)	
X851	1	1	FQ04003010	Ceramic Vib. 400KHz	
PH00-MAIN FILTER CIRCUIT BOARD					
PH00	1	1	YK101K1770	P.W. Board, Main Filter	
	1		ZZ101K8770	P.W. Board Assembly	
PH00-CAPACITORS					
ΔCH01	1		DF17154810	Film	0.15μF ±20%
ΔCH01	1	1	DF17104810	Film	0.1μF ±20%
ΔCH02	1		DF17154810	Film	0.15μF ±20%
ΔCH03	1		DK16471800	Ceramic	470pF ±10%
ΔCH03	1	1	DK16221800	Ceramic	220pF ±10%
ΔCH04	1		DK16471800	Ceramic	470pF ±10%
ΔCH04	1	1	DK16221800	Ceramic	220pF ±10%
PH00-MISCELLANEOUS					
JH01					
JH04	4	4	YP10001130	Plug	
ΔLH01	1	1	LC11560010	Choke Coil, 15mH x 2	
PR00-POWER IND. CIRCUIT BOARD					
PR00	1	1	YK101K1720	P.W. Board, Power Ind.	
	1		ZZ101K8720	P.W. Board Assembly	
DR01	1	1	HI10032030	L.E.D.	SLP171D
PR50-DISC INSIDE IND. CIRCUIT BOARD					
PR50	1	1	YK101K1730	P.W. Board, Disc Inside Ind.	
	1		ZZ101K8730	P.W. Board Assembly	
RR51	1	1	GG05122120	Resistor	1.2KΩ ±5% ¼W
DR51	1	1	HI10016050	L.E.D.	TLUG-143
DR52	1	1	HI10016050	L.E.D.	TLUG-143
DR53	1	1	HI10016050	L.E.D.	TLUG-143

• (N): for Europe
• (F): for Japan

REF. DESIG.	QTY		PART NO.	DESCRIPTION
	N	F		
PS00	1	1	YK101K1420 ZZ101K8420	PS00-PROGRAM KEY SW. CIRCUIT BOARD P.W. Board, Program Key SW. P.W. Board Assembly
RS01	1	1	GD05821140	PS00-RESISTORS 820Ω ±5% ¼W
RS02	1	1	GD05821140	820Ω ±5% ¼W
RS03	1	1	GD05821140	820Ω ±5% ¼W
RS04	1	1	GD05821140	820Ω ±5% ¼W
SS01	1	1	SP01010580	PS00-SWITCHES Push Switch, All Cancel
SS02	1	1	SP01010580	Push Switch, Program Sel
SS03	1	1	SP01010580	Push Switch, Preset
SS04	1	1	SP01010580	Push Switch, Repeat
SS05	1	1	SP01010580	Push Switch, Cancel
PU00	1	1	YK101K1430 ZZ101K8430	PU00-MODE KEY SWITCH CIRCUIT BOARD P.W. Board, Mode Key Switch P.W. Board Assembly
SU01	1	1	SP01010580	Push Switch, REV
SU02	1	1	SP01010580	Push Switch, FF
SU03	1	1	SP01010580	Push Switch, PLAY/NEXT
SU04	1	1	SP01010580	Push Switch, PLAY/NEXT
SU05	1	1	SP01010580	Push Switch, PAUSE
PU50	1	1	YK101K1440 ZZ101K8440	PU50-SIGNAL RELAY 2 CIRCUIT BOARD P.W. Board, Signal Relay 2 P.W. Board Assembly
JU51	1	1	YJ06002680	Jack
JU52	1	1	YJ06002680	Jack
JU53	1	1	YJ06002680	Jack
JU54	1	1	YP06003040	Plug
JU55	1	1	YP06003010	Plug
JU56	1	1	YP06003020	Plug
JU57	1	1	YP06003020	Plug
JU58	1	1	YP10002020	Plug
JU59	1	1	YP10001990	Plug
JU60	1	1	YP06003030	Plug
SU51	1	1	SP01010580	Push Switch, Play
WU51	1	1	YB00380030	Connective Cord, (8P)
WU52	1	1	YB00380030	Connective Cord, (8P)
WU53	1	1	YB00380030	Connective Cord, (8P)
WU54	1	1	YB00380040	Connective Cord, (6P)
WU55	1	1	YB00300640	Connective Cord, (3P)
WU56	1	1	YB00400340	Connective Cord, (4P)
WU58	1	1	YB00250170	Connective Cord, (6P)
WU59	1	1	YB00130080	Connective Cord, (3P)

REF. DESIG.	QTY		PART NO.	DESCRIPTION
	N	F		
PY00	1	1	YK101K1410 ZZ101K8410	PY00-DISPLAY CIRCUIT BOARD P.W. Board, Display P.W. Board Assembly
CY01	1	1	EA33601030	PY00-CAPACITORS Elect 33μF 10V
CY02	1	1	EA33601030	Elect 33μF 10V
CY03	1	1	DK18103300	Ceramic 0.01μF
CY04	1	1	DK18103300	Ceramic 0.01μF
RY01	1	1	GD05821140	PY00-RESISTORS (All Resistors are ±5% and ¼W) 820Ω
RY02	1	1	GD05821140	820Ω
RY03	1	1	GD05821140	820Ω
RY04	1	1	GD05821140	820Ω
RY05	1	1	GD05680140	68Ω
RY06	1	1	GD05332140	3.3KΩ
RY07	1	1	GD05821140	820Ω
QY01	1	1	HC10012360	PY00-SEMICONDUCTORS IC MM5450N
QY02	1	1	HC10017270	IC HEF4094
DY01	1	1	HI10017050	L.E.D. TLPG-144
DY02	1	1	HI10017050	L.E.D. TLPG-144
DY03	1	1	HI10017050	L.E.D. TLPG-144
DY04	1	1	HI10017050	L.E.D. TLPG-144
DY05	1	1	HI10017050	L.E.D. TLPG-144
DY06	1	1	HI10017050	L.E.D. TLPG-144
DY07	1	1	HI10017050	L.E.D. TLPG-144
DY08	1	1	HI10017050	L.E.D. TLPG-144
DY09	1	1	HI10017050	L.E.D. TLPG-144
DY10	1	1	HI10017050	L.E.D. TLPG-144
DY11	1	1	HI10017050	L.E.D. TLPG-144
DY12	1	1	HI10017050	L.E.D. TLPG-144
DY13	1	1	HI10017050	L.E.D. TLPG-144
DY14	1	1	HI10017050	L.E.D. TLPG-144
DY15	1	1	HI10017050	L.E.D. TLPG-144
DY51	15	15	HI10040020	L.E.D. LN422YP
DY65	1	1	HI10030020	L.E.D. LN224RP
DY71	1	1	HI10030020	L.E.D. LN224RP
DY72	1	1	HI10030020	L.E.D. LN224RP
DY81	1	1	HD20005010	Diode W06B
DY82	1	1	HD20005010	Diode W06B
JY01	1	1	YP06003040	PY00-MISCELLANEOUS Plug
JY02	1	1	YP06003040	Plug
JY58	1	1	YP06003040	Plug
WY01	1	1	YB00240050	Connective Cord, (6P)
WY02	1	1	YB00150340	Connective Cord, (6P)

• (N): for Europe
• (F): for Japan

REF. DESIG.	Q'TY		PART NO.	DESCRIPTION
	N	F		
PZ00	1	1	YK101K1750 ZZ101K8750	PZ00-MODE INDICATOR CIRCUIT BOARD
	1			P.W. Board, Mode Indicator P.W. Board, Assembly
				PZ00-RESISTORS (All Resistors are $\pm 5\%$ and $\frac{1}{4}W$)
RZ01	1	1	GD05103140	10K Ω
RZ02	1	1	GD05152140	1.5K Ω
RZ03	1	1	GD05103140	10K Ω
RZ04	1	1	GD05223140	22K Ω
RZ05	1	1	GD05121140	120 Ω
				PZ00-SEMICONDUCTORS
DZ01	1	1	HI10021300	L.E.D. PR2533D
DZ02	1	1	HI10022300	L.E.D. BG2533D
DZ03	1	1	HI10023300	L.E.D. AY2533D
QZ01	1	1	HT605571B0	Transistor BC557(B)
QZ02	1	1	HT605571B0	Transistor BC557(B)

REF. DESIG.	Q'TY		PART NO.	DESCRIPTION
	N	F		
PZ50	1	1	YK101K1760 ZZ101K8760	PZ50-SIGNAL RELAY 1 CIRCUIT BOARD
	1			P.W. Board, Signal Relay 1 P.W. Board Assembly
JZ51	1	1	YJ06002680	Jack
JZ52	1	1	YJ06002680	Jack
JZ53	1	1	YJ06002680	Jack
JZ54	1	1	YJ06002450	Jack, (6P)
JZ55	1	1	YJ06002430	Jack, (3P)
JZ56	1	1	YJ06002440	Jack, (4P)
JZ57	1	1	YJ06002440	Jack, (4P)
JZ58	1	1	YJ06002450	Jack, (6P)
JZ59	1	1	YJ06002450	Jack, (6P)
WZ58	1	1	YU06340260	Jumper Lead, (6P)
WZ59	1	1	YU05320260	Jumper Lead, (5P)

(W01-99)	Assembly and Wiring
(T01-99)	Adjustment
(X01-00)	Correction

NOTE ON SAFETY:

Symbol \triangle Fire or electrical shock hazard. Only original parts should be used to replace any part marked with symbol \triangle . Any other component substitution (other than original type), may increase risk of fire or electrical shock hazard.

m 3610

11. TECHNICAL SPECIFICATIONS

AUDIO PERFORMANCE

Number of Channels	2
Frequency Range	20–20,000 Hz
Dynamic Range	>90 dB
Signal-to-Noise Ratio	>90 dB
Channel Separation	>90 dB
Total Harmonic Distortion (incl. noise)	<0.005%
Wow and Flutter	quartz crystal precision
D/A Conversion	16 bit with digital filtering
Error Correction System	Cross Interleave Reed Solomon Code (CIRC)
Audio Output Level	2 V rms

OPTICAL READOUT SYSTEM

Laser	semi-conductor AlGaAs
Wave length	0.78 μ m

SIGNAL FORMAT

Sampling Frequency	44.1 kHz
Quantization	16 bit linear/channel

DISC

Diameter	120 mm
Thickness	1.2 mm
Sense of rotation (seen from reading side)	anti-clockwise
Scanning velocity	1.2–1.4 m/s
Rotation speed	500–200 rpm
Playing time (max)	60 min (stereo)
Track pitch	1.6 μ m
Material	plastic

POWER SUPPLY

Mains Voltage	see type plate at the bottom of the player
Mains Frequencies	50 and 60 Hz
Power Consumption	40 W approx
Safety Requirements	IEC



CABINET, GENERAL

Material/finish	polystyrene with extruded aluminium profiles
This model is convertible to 110/120/220/240 volts by changing voltage selector on the rear panel.	
Dimensions (W x H x D)	
with drawer closed	416 x 81 x 300 mm
with drawer open	416 x 130 x 483 mm
Weight	8 kg approx
Connection Cable	fitted with moulded cinch plugs

Specifications and appearance are subject to change for modification without notice.

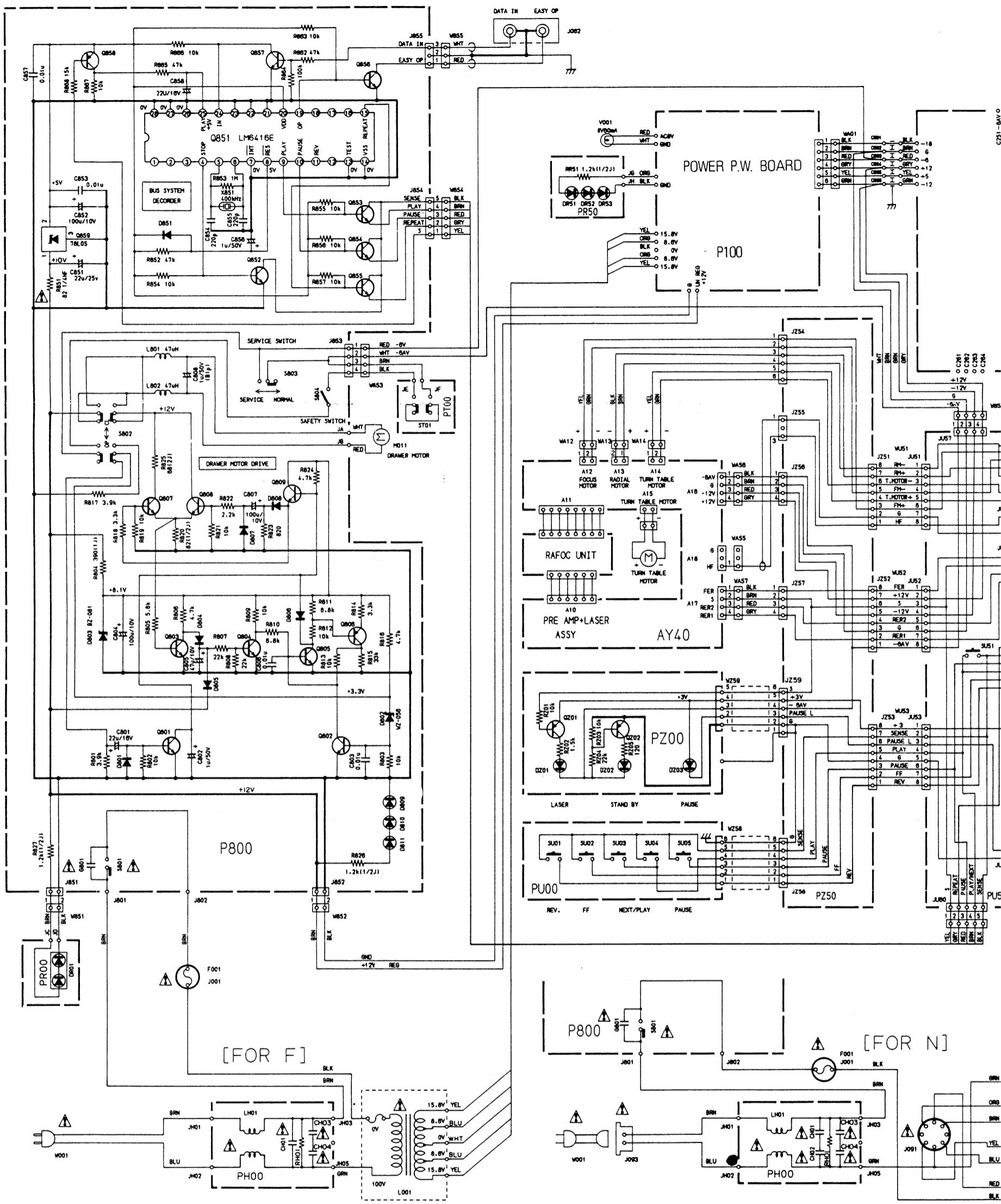
12. SCHEMATIC DIAGRAM



NOTE ON SAFETY :
 Symbol  Fire or electrical shock hazard. Only original parts should be used to replace any part marked with symbol . Any other component substitution (other than original type), may increase risk of fire or electrical shock hazard.

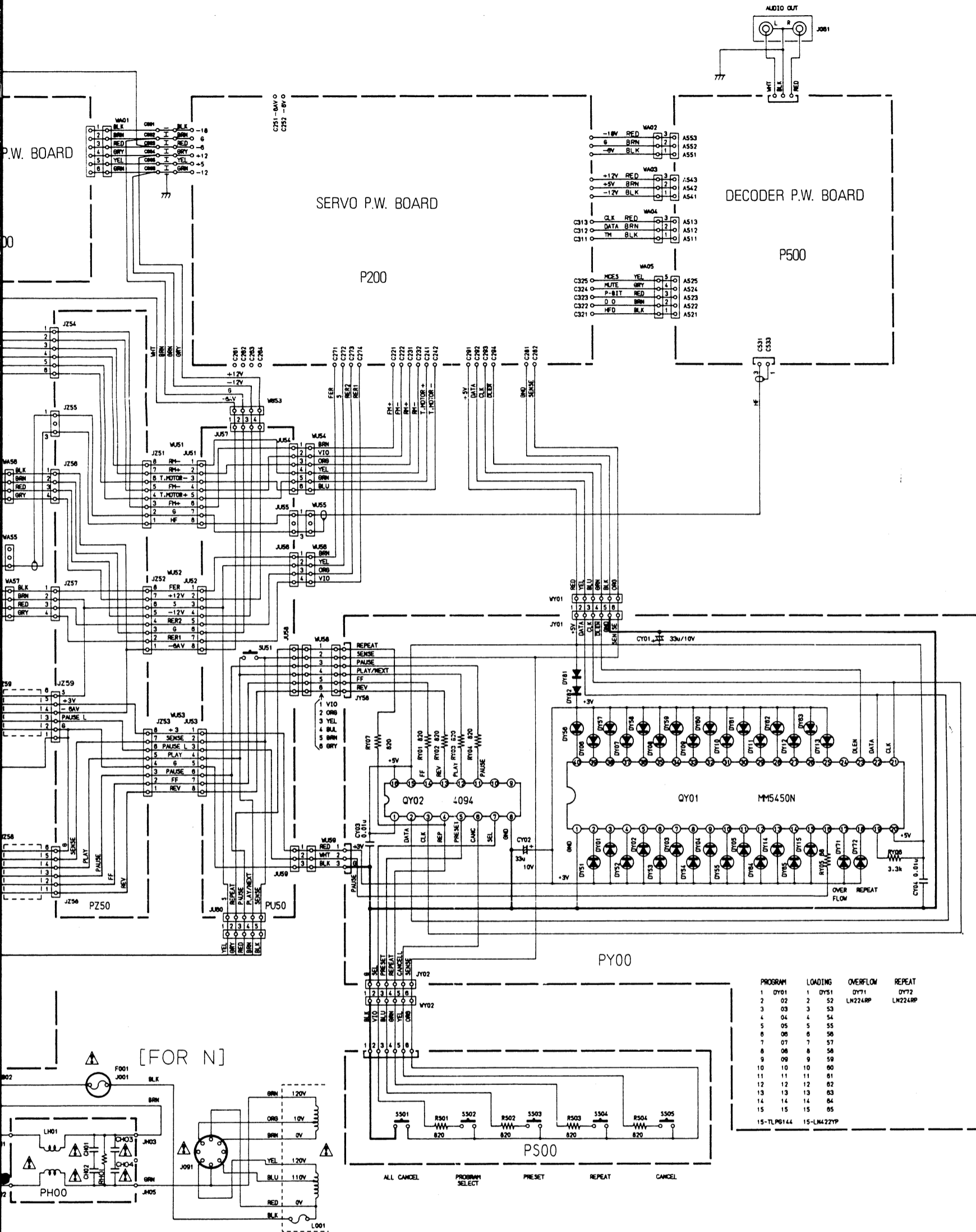

PROGRAM	LOADING	OVERFLOW	REPEAT
1	DY01	DY71	DY72
2	02	2	52
3	03	3	53
4	04	4	54
5	05	5	55
6	06	6	56
7	07	7	57
8	08	8	58
9	09	9	59
10	10	10	60
11	11	11	61
12	12	12	62
13	13	13	63
14	14	14	64
15	15	15	65

15-TL98144 15-LN422YP

Components and wiring are subject to change for modification without notice.

m 3613