



SERVICE MANUAL

CD-74

This service manual explains them by extracting the different specifications from those of the CD-84 (N), based on the CD-84 (N). For both electrical and mechanical information on the after-sales service which is not stated, all information is described in the CD-84 (N) service manual. The dispatch of the parts for after-sales service has to be referred to this service manual, with the first priority.

For this reason, please use this service manual with referring to the CD-84 (N) service manual, without fail.

SHOCK, FIRE HAZARD SERVICE TEST:

CAUTION: After servicing this appliance and prior to returning to customer, measure the resistance between either primary AC cord connector pins (with unit NOT connected to AC mains and its Power switch ON), and the face or front Panel of product and controls and chassis bottom.

Any resistance measurement less than 1 Megohms should cause unit to be repaired or corrected before AC power is applied, and verified before return to user/customer.

Ref. UL Standard NO. 1270. Para. 66.3D (Mandatory Test after servicing Electrical Appliances, effective 7-1-83).

Finnish: VAROITUS. Laite sisältää laserdiodin, joka lähettää (näkymätöntä) simille vaarallista lasersäteilyä.

Original Model CD-84 (N.A)			Model CD-74					
Page	REF. DESIG.	PART NO.	QTY			PART NO.	DESCRIPTION	
			U	N	A			
42	R311	Ri01823180	1	1	1	GM21482520	Resistor 82.5K Ω	
	R312	Ri01823180	1	1	1	GM21482520	Resistor 82.5 Ω	
	R384	GA05082020	1	1	1	GA05039020	Resistor 3.9 Ω	
	R385	GA05082020	1	1	1	GA05039020	Resistor 3.9 Ω	
	D251	HD30041010				_____	Delete	
	Q205	HC10081060	1	1	1	HC10010320	IC IR2339	
	Q207	HC10055010	1	1	1	HC402500B0	IC μ p D4025BC	
	Q211	HC10056010	1	1	1	HC405300B0	IC μ p D4053BC	
	Q212	HC10082060	1	1	1	HC10008320	IC IR3702	
	Q214	HC10082060	1	1	1	HC10008320	IC IR3702	
	Q215	HC10082060	1	1	1	HC10008320	IC IR3702	
	Q218	HC10083060	1	1	1	HC10011320	IC IR3741	
	43	C606	DF55122530				_____	Delete
		C612	DF55222510				_____	Delete
		C627	EA10701660	1	1	1	EA47602560	Elect 47 μ F 25V
C628		EA10701660				_____	Delete	
C631		_____	1	1	1	DF55122530	Film 1200PF \pm 5%	
C652		DF55222510				_____	Delete	
R518		_____	1	1	1	GD05103140	Resistor 10K Ω	
L502	LC14730040				_____	Delete		
45	R810	GD05102140	1	1	1	GD05332140	Resistor 3.3K Ω	
	Δ Q801	FU20215010	1	1	1	FU27215010	Protector Unit ICP-F75	
	Δ Q804	_____	1	1	1	FU40115010	Protector Unit ICP-F10	
	Δ Q820	_____		1	1	FU40115020	Protector Unit ICP-N10	
	PH00	WB106K1860				_____	Delete	
		ZZ106K8860				_____	Delete	
	Δ CH01	DF77154810				_____	Delete	
	Δ CH02	DF77154810				_____	Delete	
	Δ RH01	RC05224120				_____	Delete	
	Δ LH01	TZ11560010				_____	Delete	
	SS01	SP01010800	16	16	16	SP01010570	Push Switch	
	SS16							
CT04	DK46103300				_____	Delete		
CT13	OA22703510	1	1	1	OA47603510	Elect 47 μ F 35V		
46	PU10	WB106K1880	1			WB106K1880	P.W. Board Headphone	
		ZZ106K1880	1			ZZ110K1880	P.W. Board Assembly	
	PJ21	YJ01001790	1			YJ01002080	Jack Headphone	
	PW10	WB106K1850	1			WB106K1850	P.W. Board RCA Output Volume	
		ZZ106K8850	1			ZZ106K1850	P.W. Board Assembly	
	WT03	YT02020330	1	1	1	YT02020420	Terminal 2P RCA Jack	
SX01	SP01010800	1	1	1	SP01010570	Push Switch Tact		

Original Model CD-84 (N.A)			Model CD-74				
Page	REF. DESIG.	PART NO.	Q'TY			PART NO.	DESCRIPTION
			U	N	A		
46	SY01 }	SP01010800	4	4	4	SP01010890	Push Switch Tact
	SY04 SY05 }	SP01010800	8	8	8	SP01010570	Push Switch Tact
	PZ20	WB106K2430 ZZ106K2430				_____	Delete Delete
	CZ01	DK46333300				_____	Delete
	CZ02	DK46472300				_____	Delete
	CZ03	EJ10601610				_____	Delete
	CZ04	EJ47502510				_____	Delete
	CZ05	EJ10601610				_____	Delete
	CZ05	EJ47601610				_____	Delete
	47	RZ01	RI05224180				_____
RZ02		RI05120180				_____	Delete
RZ03		RI05102180				_____	Delete
DZ01		HI60001060				_____	Delete
QZ01		HC10071060				_____	Delete
LZ01		LA74020010				_____	Delete
PT51		YF113K1210 ZZ113K1210				_____	Delete Delete
CT51		DK16121300				_____	Delete
CT52		DK16471300				_____	Delete
CT53		OA47405010				_____	Delete
RT51		GD05102140				_____	Delete
RT52		GD05022140				_____	Delete
QT51		HI10030020				_____	Delete
QT52		HI20003320				_____	Delete
QT53		HI20003320				_____	Delete
QT54		HT320011KO				_____	Delete
QT55		HC10070060				_____	Delete
DT51		HD20001210				_____	Delete
DT55							
FT51		FQ04003020				_____	Delete
PT52		YF113K1220 ZZ113K1220				_____	Delete Delete
ST51		SS01020510				_____	Delete



**SERVICE
MANUAL**

CD-84

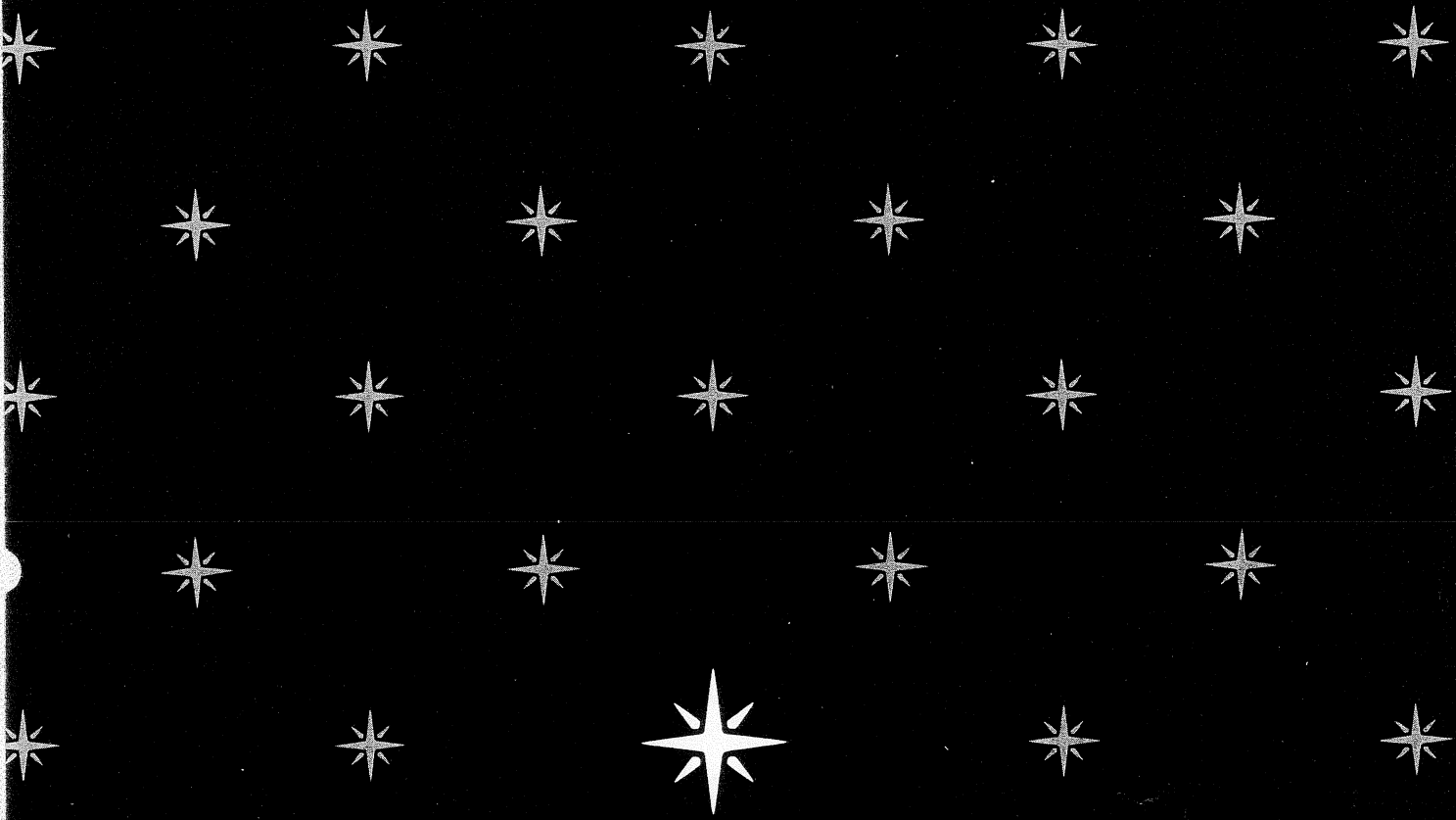

marantz®

model CD-84

Compact Disc Digital Audio Player

MARANTZ DESIGN AND SERVICE

Using superior design and selected high grade components, MARANTZ company has created the ultimate in stereo sound. Only **original MARANTZ parts** can insure that your MARANTZ product will continue to perform to the specifications for which it is famous.

Parts for your MARANTZ equipment are generally available to our National Marantz Subsidiary or Agent.

ORDERING PARTS:

Parts can be ordered either by mail or by telex. In both cases, MARANTZ part number has to be specified. If you order by mail, fulfil MARANTZ order forms.

MARANTZ S.A.
EUROPEAN PARTS DEPARTMENT
2, Avenue Léopold III
B-7120 PERONNES-lez-BINCHE
BELGIUM
TWX: 57589 SEPLT B

The following information must be supplied to eliminate delays in processing your order:

1. Complete address
2. Complete part numbers and quantities required
3. Description of parts
4. Model number for which part is required
5. Way of shipment
6. Signature: any order form or telex must be signed otherwise such part order will be considered as null and void.

PARTS ORDERING:

Parts may be ordered from the following addresses:

EUROPE

MARANTZ S.A.

European Parts Department
2, Avenue Léopold III
B-7120 Péronnes-lez-Binche
Belgium
Telex: 57589

MARANTZ DENMARK

Bregnerødvej 132b
3460 Birkerød
Denmark
Telex: 39137

MARANTZ BELGIUM

45 Rue Auguste Van Zande
1080 Brussels
Belgium

MARANTZ NEDERLAND B.V.

Wagenmackersweg 3
3449 HV Woerden
Netherlands

MARANTZ S.A.

326 Avenue Louise Bte 32
1050 Bruxelles
Belgium
Telex: 26602

MARANTZ FRANCE

4 Rue Bernard Palissy
92600 Asnières
France
Telex: 611651

MARANTZ SVENSKA A.B.

Svartviksvägen 56
Träneberg Bromma
Sweden
Telex: 13449

MARANTZ ITALIANA S.p.A.

Via Monte Napoleone, 10
20121 Milano
Italy

MARANTZ GERMANY G.M.B.H.

Max-Planckstrasse 22
6072 Dreieich 1
Germany
Telex: 4185316

MARANTZ AUDIO U.K. LTD.

Unit 15/16
Saxon Way Industrial Estate
Moor Lane
Harmondsworth UB7 OLW
Great Britain
Telex: 935196

MARANTZ AUSTRIA Ge.M.B.H.

25 Franz Lisztgasse
2380 Perchtoldsdorf
Austria
Telex: 113583

AUSTRALIA

MARANTZ AUSTRALIA PTY., LTD.

19 Chard Road
Brookvale, NSW 2100
Australia
Telex: 24121

All of the above locations are fully equipped to take care of your total service needs. Because various countries have differing configuration requirements, it is necessary that you contact the service facility in your particular country. In the event that there is no service location listed for your country, please, contact the nearest facility for the necessary assistance.

In case of difficulties, do not hesitate to contact the Technical Department at abovementioned address.

marantz®

MARANTZ MODEL CD-84 COMPACT DISC

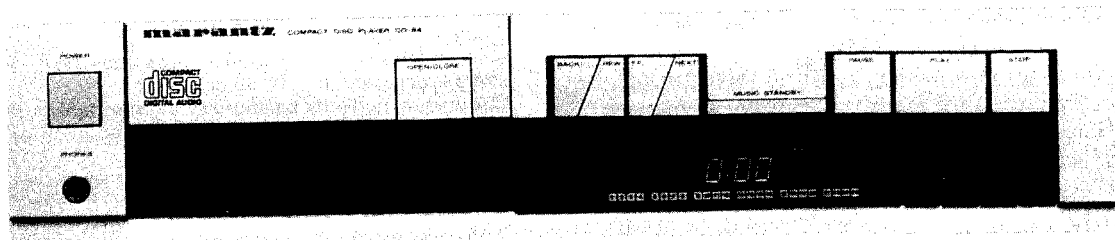

TABLE OF CONTENTS

Section	Title	Page
INTRODUCTION	2
1. P.W. BOARDS	2
2. FEATURES	2
3. LASER RADIATION SAFETY	3
4. NOTES ON ELECTROSTATIC DAMAGE	4
5. TRANSPORTATION SCREW	4
6. VOLTAGE CONVERSION	4
7. HOW TO DISASSEMBLE	5
8. ADJUSTMENT AND MEASUREMENT	6
9. DESCRIPTION OF CIRCUIT	8
10. BLOCK DIAGRAM	15
11. WIRING DIAGRAM	17
12. P.W. BOARD DIAGRAM	19
13. SEMICONDUCTORS ELECTRODES	22
14. SCHEMATIC DIAGRAM	23
15. REMOTE CONTROLLER (RMC-84) WIRING DIAGRAM AND SCHEMATIC DIAGRAM	32
16. EXPLODED VIEWS AND PARTS LIST	33
17. ELECTRICAL PARTS LIST	41
18. SPECIFICATIONS	48

INTRODUCTION

This service manual are prepared for use by Authorized Warranty Station and contains service information for Marantz Compact Disc.

Service information and voltage data included in this manual are intended for use by the knowledgeable and experienced technician only. All instructions should be read carefully. No attempt should be made to proceed without a good understanding of the operation of the Compact Disc.

The parts list furnishes information by which replacement parts may be ordered from the Marantz Company. A simple description is included for parts which can be usually obtained through local suppliers.

1. P.W. BOARDS

As can be seen from the circuit diagram, the chassis of your Compact Disc consists of the following units. Each unit mounted on a printed circuit board is described within the square enclosed by a bold dotted line on the circuit diagram.

1. Servo mounted on P.W.Board P200
2. Decoder and Headphones Amp.
. mounted on P.W.Board P500
3. Power Supply and Motor Drive
. mounted on P.W.Board P800
4. Filter mounted on P.W.Board PH00
5. Power Switch mounted on P.W.Board PS10
6. Ten Key Switch mounted on P.W.Board PS20
7. Featuer μ -com mounted on P.W.Board PT10
8. Headphone mounted on P.W.Board PU10
9. RCA Terminals mounted on P.W.Board PW10
10. Tray Open Close Sw. mounted on P.W.Board PX20
11. Front Display mounted on P.W.Board PY20
12. Sensor mounted on P.W.Board PZ20
13. Sub Chassis mounted on P.W.Board P100

MEASURING EQUIPMENT AND TEST DISC REQUIRED FOR SERVICING

- DC voltmeter
- Distortion meter
- Low pass filter
- Spectrum analyzer
- Oscilloscope
- Phase meter
- Frequency counter
- Test disc

2. FEATURES

The compact disc system is an epoch-making audio system which makes the best of state-of-the-art digital techniques.

HIGH-PERFORMANCE

The CD-84 is extremely superior in performance to the conventional analog audio systems as demonstrated by the following characteristics.

- Frequency range: 4 Hz to 20 kHz
- Dynamic range: 90 dB or greater
- Distortion factor: 0.003%
- Wow and flutter: less than measurable limit
- Channel separation: 90 dB or greater

Our unique, perfectly balanced swing mechanism provides excellent anti-vibration characteristics and immunity against oblique setting.

HIGH QUALITY SOUND

The newly developed digital filter, large-scale power transformer, audio capacitor and other high grade parts enable the conversion of all the information recorded on the disc into high quality sound.

VARIETY OF FUNCTIONS

Each audio disc contains various information other than music (e.g., selection numbers, length of each selection, etc.) and the CD-84 reads this information to provide many useful functions.

RANDOM ACCESS PROGRAMMING

Any number of selections (up to 24) can be automatically played in the desired order using the random access programming function.

DELETE PROGRAMMING

Any selections can be skipped automatically by using the delete programming function.

ALL PLAY

Of course, all selections can be played in the recorded order.

AUTO MUSIC SCAN

When the AMS (Auto Music Scan) button is pressed, the beginning of each selection recorded on the disc is automatically played for 10 seconds.

QUICK TUNE SELECTION

When the music No. is specified, play starts promptly from the beginning of the desired tune.

TUNE SELECTION WITH INDEX NO.

The CD-84 enables you to select tunes by their Index Nos.

TUNE SELECTION WITH TIME PROGRAMMING

Tune selection by specifying time is also possible.

SKIP FEATURE

By pressing the NEXT button during play you can skip selections. The number of selections skipped corresponds to the numbers of times the button is pressed and play starts from the beginning of the selected tune.

BACK SKIP FEATURE

When the BACK button is pressed once during play, the unit enters pause mode at the beginning of the current selection. When the button is pressed twice, the unit returns to the beginning of the previous selection and enters pause mode. This feature is useful for recording.

REPEAT FEATURE

Either all or selected selections can be played repeatedly.

A-B REPEAT FEATURE

When the beginning and end of the section to be played repeatedly is specified, the section can be played repeatedly.

• MUSIC STANDBY FEATURE

With this feature, the unit pauses at the beginning of the specified selection. This feature is useful for recording.

3. LASER RADIATION SAFETY

Protection of eyes from laser beam during servicing
This set employs a laser. Therefore, be sure to carefully follow the instructions below when servicing.

1. Laser Diode Properties

- Material: Al Ga As
- Wave Length: 0.78 μm
- Emission Duration: Continuous
- Laser Output: Max. 0.11 mW

This output is the value measured at the objective lens surface on the light pen assembly.

- Classification: Class IIIb

2. During service, do not take the subchassis block apart and do not adjust the H F amp circuit. If there is a breakdown in the H F circuit (including laser diode), replace the entire subchassis block (including H F amp circuit board).

WARNING!!

When servicing, do not approach the laser exit with the eye too closely.

In case it is necessary to confirm laser beam emission, be sure to observe from a distance of more than 30 cm from the surface of the objective lens on the light pen assembly.

LASER WARNING LABELS

The labels shown below are affixed.

- 1) DHHS Protective housing label
"DANGER - INVISIBLE LASER RADIATION WHEN OPEN. AVOID DIRECT EXPOSURE TO BEAM."
- 2) DNHW Protective housing label and laser radiation sign label
"CAUTION - HAZARDOUS LASER RADIATION WHEN OPEN AND INTERLOCK DEFEATED."
"ATTENTION - RAYONNEMENT LASER DANGEREUX SI OUVERT AVEC L'ENCLANCHEMENT DE SECURITE ANNULE."

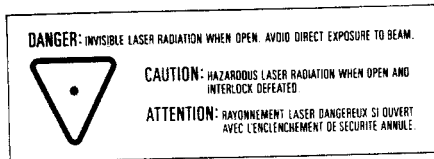

Warning Label

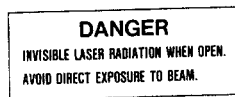
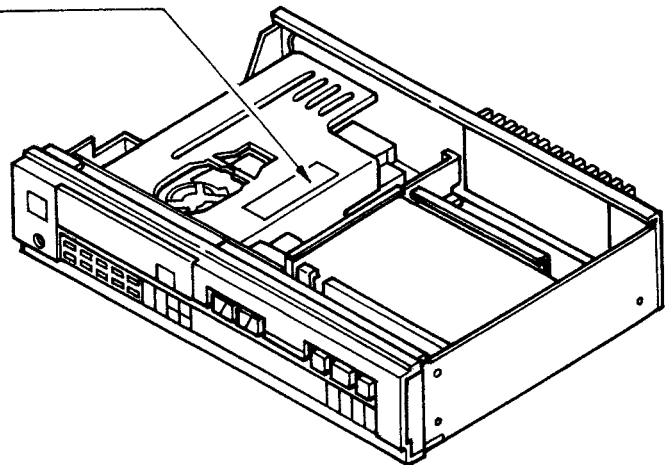

Bottom Cover

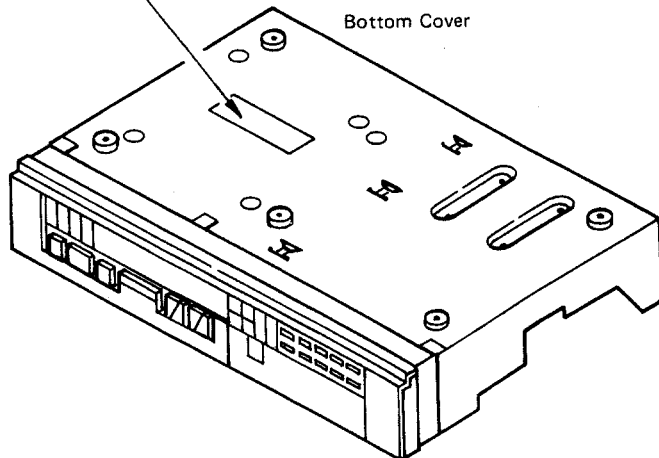

4. NOTES ON ELECTROSTATIC DAMAGE

When handling the laser diode of the optical pick-up or the MOS IC, be sure not to damage them with electrostatic. The electrostatic level charged in the human body and clothing varies with ambient conditions. However, simply walking will produce an electrostatic charge of more than several kV. With synthetic fiber clothing, an electrostatic charge of about 10 ~ 30 kV will be produced on a dry day. If the charged electrostatic voltage is applied to the electrode of the semi-conductor, the electrode may be damaged easily. When handling the laser diode or the MOS IC, pay attention to the following points.

1. Lay a conductive sheet on the work bench and ground it.
2. Ground the soldering iron.
3. Do not wear synthetic fiber gloves or clothing. During operation, be sure to put on the wrist strap shown below.

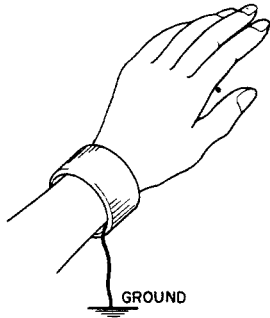

4. Use a conductive material to store the semi-conductors and short-circuit the electrodes or wrap them in aluminium foil to keep the potential at each electrode the same.

5. TRANSPORTATION SCREW

To prevent the laser pick-up from damage during transportation, the pick-up is secured with two screws. After unpacking, be sure to remove two screws. After servicing, do not forget to fix the laser pick-up with two screws.

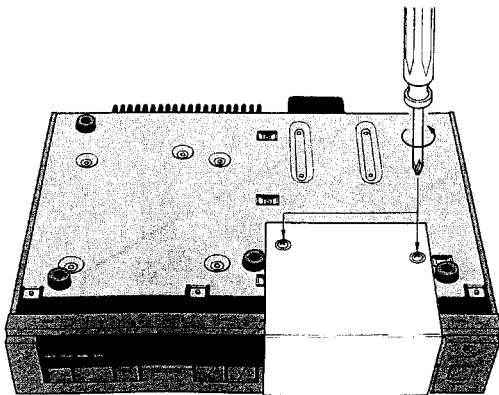

6. VOLTAGE CONVERSION

• EUROPEAN MODEL ONLY

To convert the unit to a different power source voltage, change the position as illustrated in the drawing below.

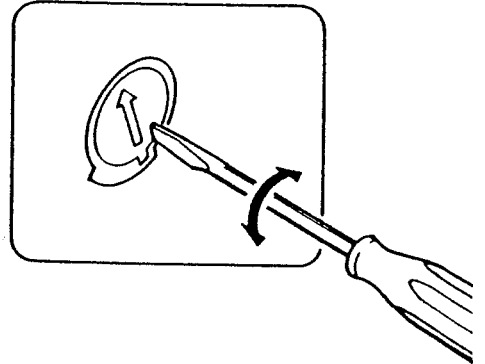

CAUTION:

DISCONNECT POWER SUPPLY CORD FROM AC OUTLET BEFORE CONVERTING VOLTAGE. DO NOT DISASSEMBLE THE VOLTAGE SELECTOR ABSOLUTELY.

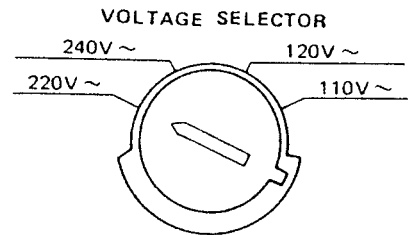

NOTE ON SAFETY:

SYMBOL Δ FIRE OR ELECTRICAL SHOCK HAZARD. ONLY ORIGINAL PARTS SHOULD BE USED TO REPLACE ANY PART MARKED WITH SYMBOL Δ . ANY OTHER COMPONENT SUBSTITUTION (OTHER THAN ORIGINAL TYPE), MAY INCREASE RISK OF FIRE OR ELECTRICAL SHOCK HAZARD.

7. HOW TO DISASSEMBLE

7-1. HOW TO REMOVE THE FRONT PANEL AND FRONT CHASSIS

Remove screws ①~③, disengage claws indicated with arrows and remove the front panel.
Remove screws ④~⑨ and remove the front chassis.

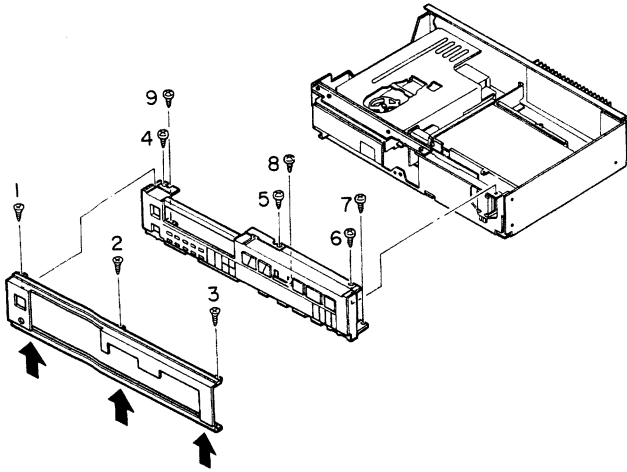

7-3. HOW TO REMOVE THE TRAY DRIVE MECHANISM

Remove screws ①~③ from the motor chassis and take out the tray in the direction of arrow B.

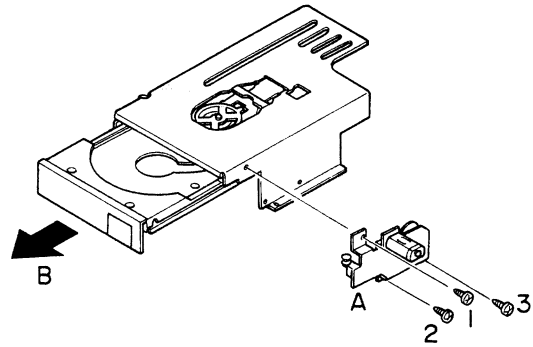

7-2. HOW TO REMOVE THE DISC TRAY

Remove screws ①~④ remove bracket A, remove screws ⑤~⑦ and remove the disc tray chassis.

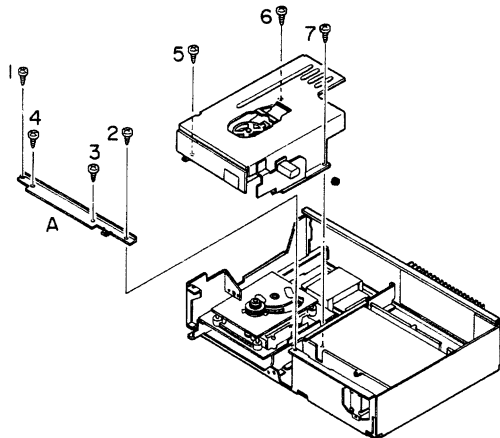

7-4. HOW TO REMOVE THE SUB CHASSIS

Take out the sub chassis upward.

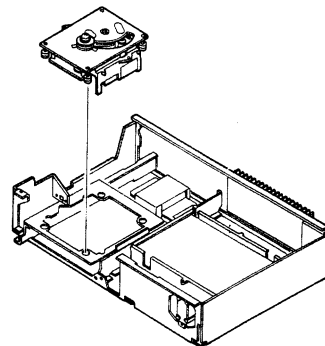

8. ADJUSTMENT AND MEASUREMENT

8-1. SUB CHASSIS ADJUSTMENT

8-1-1. Laser Output Adjustment

- (1) Play track 1 of the test disc (410055-2).
- (2) Connect a DC voltmeter between the emitter of Q239 and the ground of servo P.W. BOARD (P200).

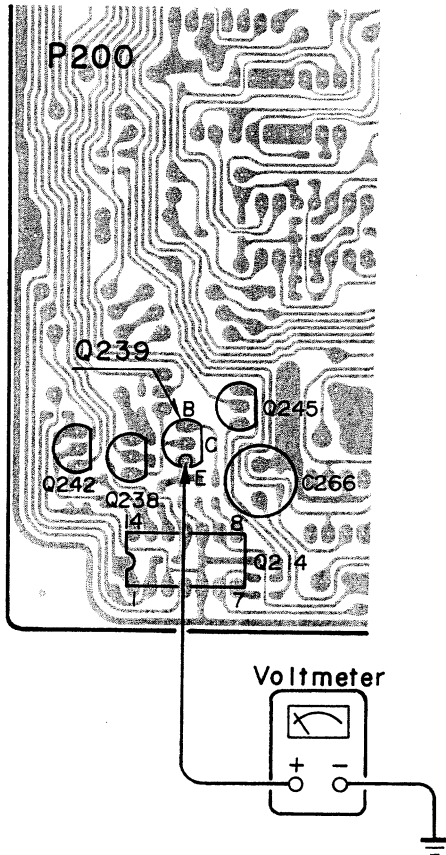

- (3) Adjust R180 so the DC voltmeter reads 500 mV \pm 30 mV.

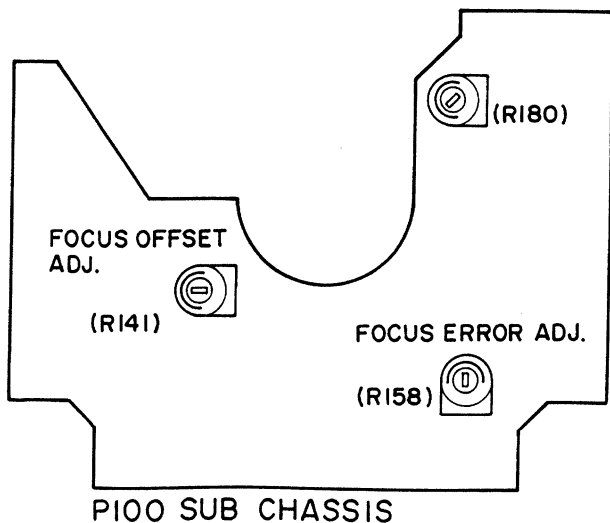

NOTE: If the test disc is not available, play the first track of a commercially available music disc.

8-1-2. Turntable Height Adjustment

To adjust the sub chassis objective lens movable range, proceed as follows.

- (1) Play track 1 of the test disc (410055-2).
- (2) Connect the DC voltmeter to the ends of R240 of servo P.W. BOARD (P200)
- (3) The DC voltmeter should read 0 V \pm 100 mV. If not, adjust the turntable height as follows.
- (4) Turn the adjusting screw located at the bottom of the turntable motor so the voltage at the ends of R240 is 0 V.
- (5) After adjustment, play the outer part of the disc and check the voltage at the ends of R240 is within \pm 100 mV of that at the inner part.
- (6) After completion of adjustment, secure the screw with screw locking compound.

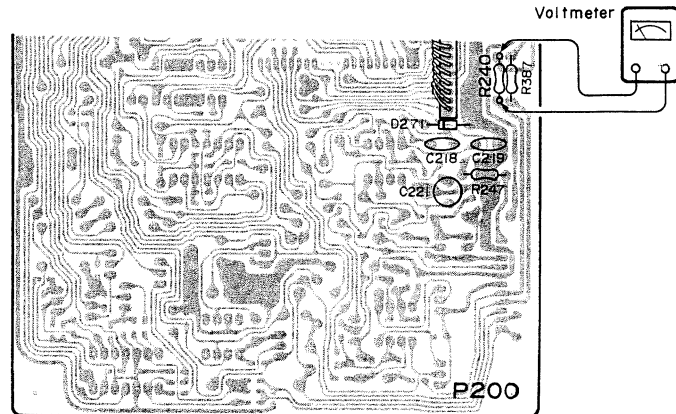

8-2. SERVO P.W. BOARD ADJUSTMENT

8-2-1. Radial DC Off-set Adjustment

- (1) Play track 1 of the test disc (410055-2).
- (2) Connect an oscilloscope between the C243 and the ground of the servo P.W. BOARD (P200).
- (3) Adjust R315 so that the oscilloscope reads 0 V \pm 0.5 V.

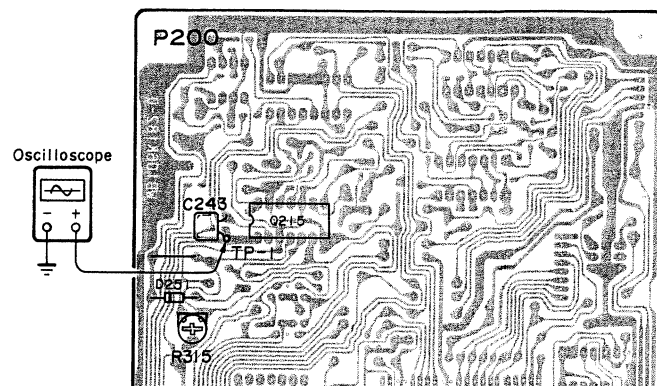

8-3. DECODER P.W. BOARD ADJUSTMENT

8-3-1. PLL Circuit Adjustment

- (1) Play track 1 of the test disc (410055-2).
- (2) Connect a voltmeter between the cross point of R509 and R510 and the ground of the decoder P.W. BOARD (P500).
- (3) Adjust L501 so the voltmeter reads $5\text{ V} \pm 100\text{ mV}$.

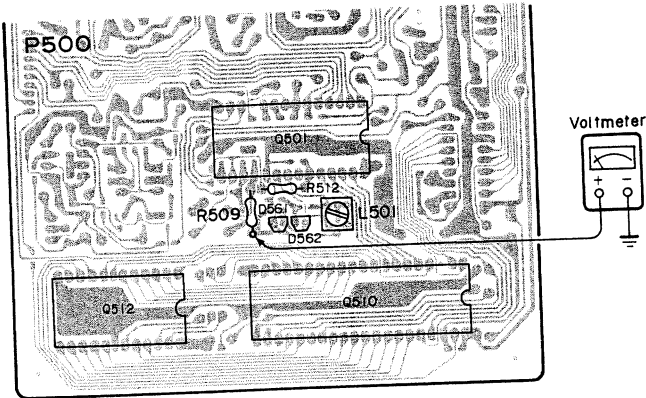

8-4. ELECTRICAL CHARACTERISTICS MEASUREMENT

8-4-1. Frequency Response

- (1) Play track 19 of the test disc (410055-2) and set the level to 0. The frequency of track 19 is 3,150 Hz.
- (2) Play the L channel of track 4 and R channel of track 8 of the test disc (410055-2) and measure the level deviation against that of track 19 (3,150 Hz) in dB. The frequencies of tracks 4 and 8 are as follows: 41 Hz, 101 Hz, 997 Hz, 3,163 Hz, 6,363 Hz, 10,007 Hz, 16,001 Hz, 19,001 Hz, 19,997 Hz.

8-4-2. Output Level and Channel Balance

- (1) Play track 19 of the test disc (410055-2) and read the level. Calculate the level difference between the right and left channels and the result should be the channel balance.

8-4-3. Distortion and Noise

- (1) Play track 4 of the test disc (410055-2) and measure the distortion. The measuring frequencies are as follows: 41 Hz, 101 Hz, 997 Hz, 3,163 Hz, 6,363 Hz, 10,007 Hz, 16,001 Hz, 19,001 Hz, 19,997 Hz.
- (2) Perform same procedures for track 8 of the test disc (410055-2).

8-4-4. Signal-to-noise Ratio (Dynamic Range)

- (1) Play track 5 of the test disc (410055-2), measure the distortion in dB and assume it as A. The measuring frequencies are as follows: 41 Hz, 101 Hz, 997 Hz, 3,163 Hz, 6,363 Hz, 10,007 Hz, 16,001 Hz, 19,001 Hz, 19,997 Hz.
- (2) Obtain the signal-to-noise ratio and dynamic range according to the following formula. Signal-to-noise ratio, dynamic range = $A + 24\text{ dB}$.
- (3) Perform same procedures for track 9 of the test disc (410055-2).

8-4-5. Channel Crosstalk Measurement

- (1) Play track 4 of the test disc and set the left channel output to 0.
- (2) Measure the non-signal level of the right channel and read the non-signal level difference against 0 dB in dB.
- (3) The measuring frequencies are as follows: 41 Hz, 101 Hz, 997 Hz, 3,163 Hz, 6,363 Hz, 10,007 Hz, 16,001 Hz, 19,001 Hz, 19,997 Hz.
- (4) Perform same procedures for track 8 of the test disc (410055-2).

9. DESCRIPTION OF CIRCUIT

9-1. PREAMPLIFIER IC μ PC1373H (QZ01)

The IC is a receive-only preamplifier in the infrared-ray remote-control system. High-gain amplifier, peak detector

and output shaping circuits required for a receiving pre-amplifier are built in one chip.

- Absolute Maximum Ratings ($T_a = 25^\circ\text{C}$)

Item	Symbol	Limit	Unit
Supply voltage	$V_{DD} - V_{SS}$	15.0	V
Power dissipation	P_d	270	mW
Operating temperature	T_{opt}	$-20 \sim +75$	$^\circ\text{C}$
Retention temperature	T_{stg}	$-40 \sim +125$	$^\circ\text{C}$

- Recommended Operating Conditions

Item	Symbol	Min.	Typ.	Max.	Unit
Supply voltage	V_{DD}	6.0	8.5	14.4	V
Frequency	f_{OSC}	30		50	kHz

- Electrical Characteristics ($T_a = 25^\circ\text{C}$, $V_{CC} = 8.5\text{V}$, $f_{in} = 40\text{kHz}$)

Item	Symbol	Measuring Condition	Min.	Typ.	Max.	Unit
Supply current	I_{CC}		1.5	2.5	3.5	mA
Input terminal voltage	V_{in1}		2.1	2.6	3.1	V
Input terminal voltage	V_{in2}	$I_{in} = 70 \mu\text{A}$	3.4	4.1	4.9	V
First stage voltage gain	A_{vL}	#7 - #3, $v_{out} = 500 \text{ mVp-p}$		60		dB
Detecting sensitivity	v_{in}			50	100	μV
Internal input resistance	r_{in}		40	60	80	$\text{k}\Omega$
Output voltage	V_{OL}	$I_{OL} = 0.1 \text{ mA}$, $v_{in} = 1 \text{ mVp-p}$			0.5	V
Output leak current	I_{OH}	$V_{OH} = 14.4\text{V}$			2	μA

- Connection Diagram

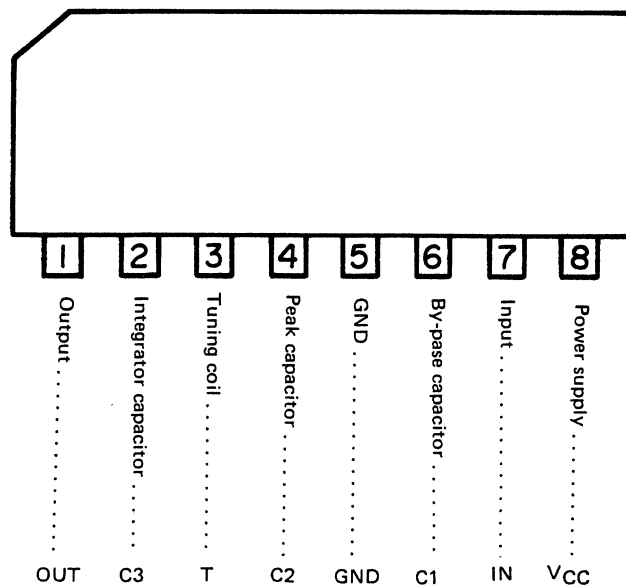

● 3 μ -COM AND KEY MATRIX CONNECTING CKT

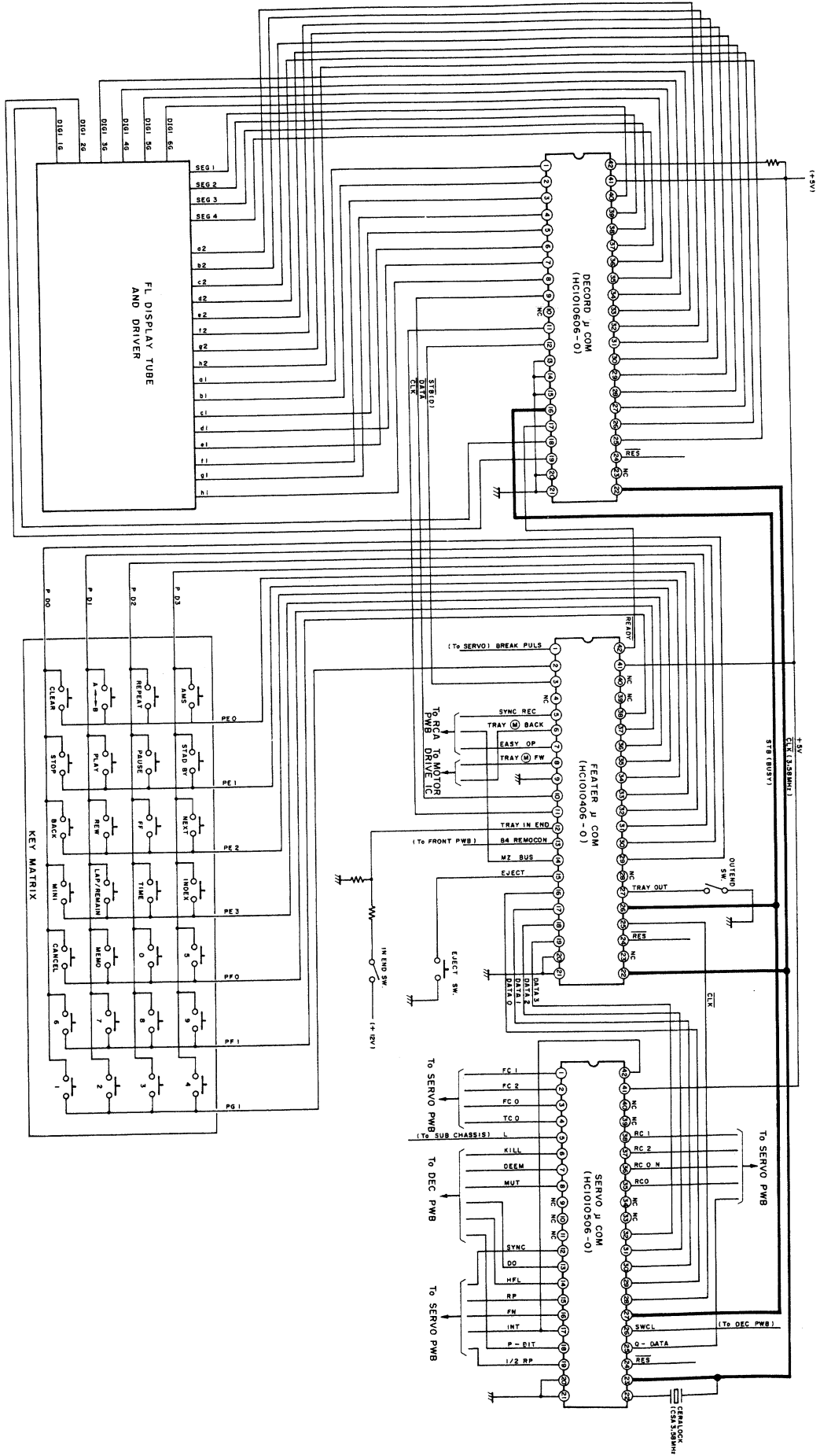

• Example of Basic Circuit

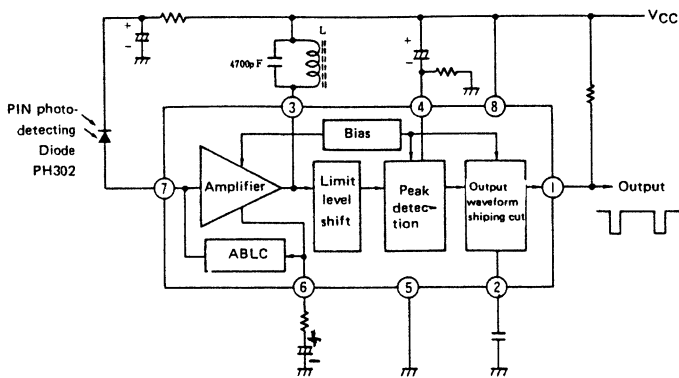

NOTE:

If the remote controller sensitivity cannot be adjusted or the coil (LZ01) setting is shifted, adjust LZ01 as shown below.

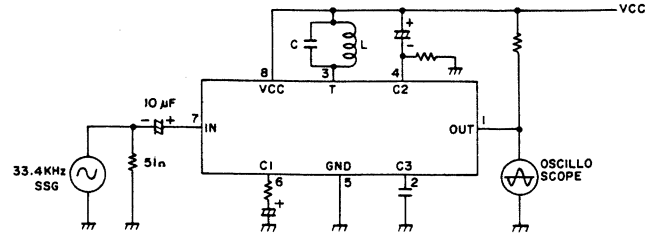

Supply a signal of 33.4 kHz from the SSG to pin (7) and adjust LZ01 so that the waveform at pin (3) becomes maximum.

9-2. µ-COM OPERATION

DECORDER U-COM (QY01)

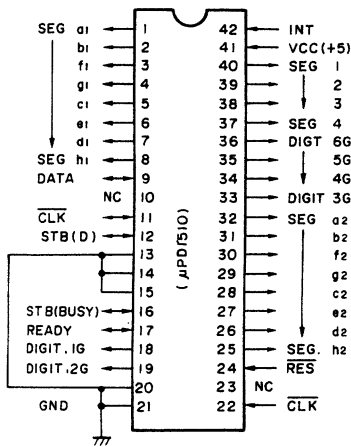

FEATUER U-COM (QT01)

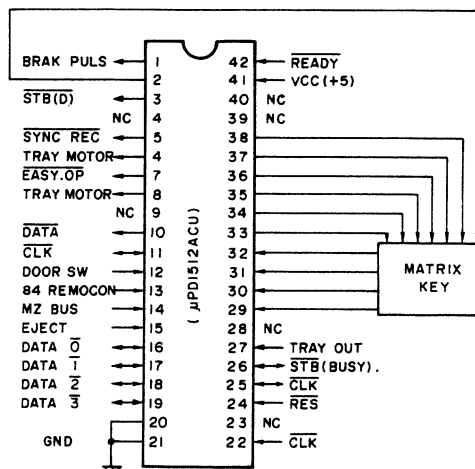

SERVO U-COM (Q201)

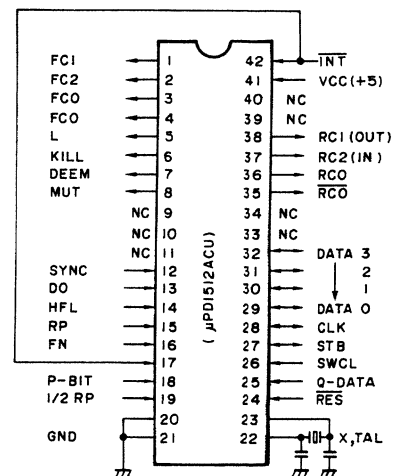

9-3. TRAY MOTOR DRIVE IC LB1645N (QM02)

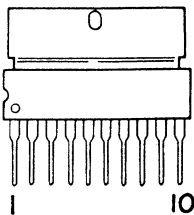

- 1. GND
- 2. OUT1
- 3. P1
- 4. VZ
- 5. IN1
- 6. IN2
- 7. Vcc1
- 8. Vcc2
- 9. P2
- 10. OUT2

• Equivalent Circuit Block Diagram

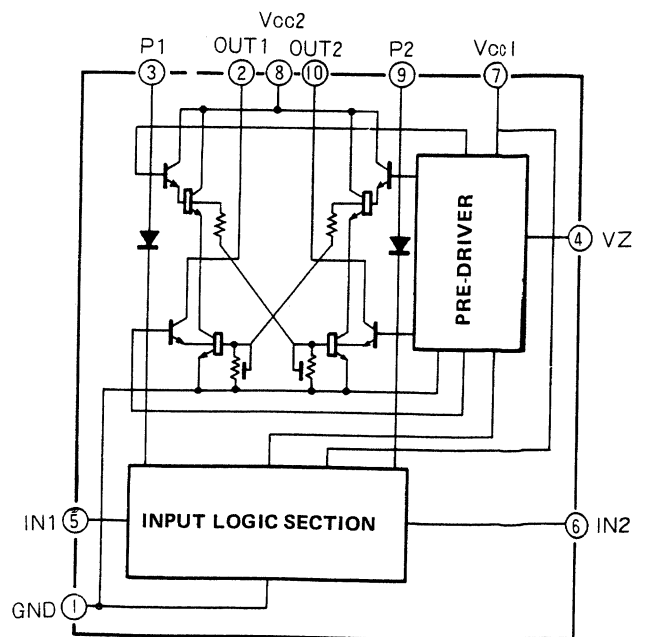

9-4. DISPLAY DRIVER MSL918RS (QY02~QY04)

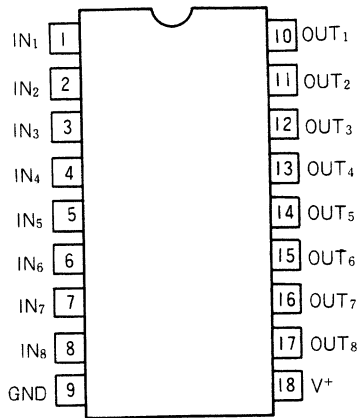

• Equivalent Schematic Diagram

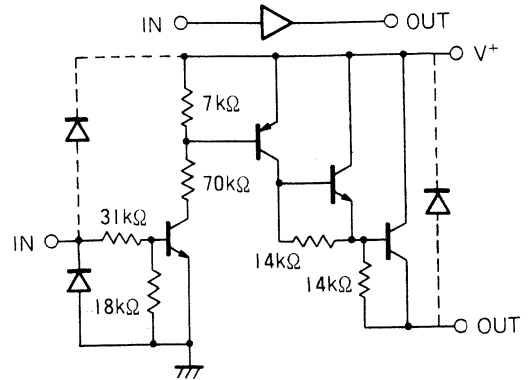

9-5. C-MOS LSI uPD6102G (QT55) FOR REMOTE CONTROL

• Pin Connection (Top View)

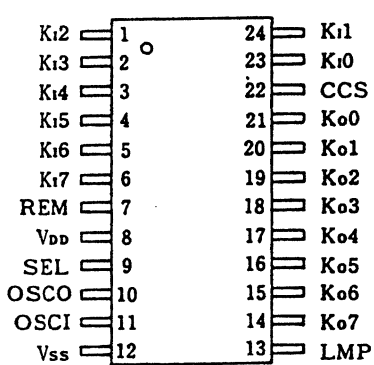

- 1. Ki2.....Key Input 2
- 2. Ki3.....Key Input 3
- 3. Ki4.....Key Input 4
- 4. Ki5.....Key Input 5
- 5. Ki6.....Key Input 6
- 6. Ki7.....Key Input 7
- 7. REMRemote Output
- 8. V_{DD}Power Terminal
- 9. SEL.....64/128Data Select
- 10. OSCOOscillator Output
- 11. OSCIOscillator Input
- 12. V_{SS}
- 13. LMPLamp Output
- 14. Ko7.....Key Output 7
- 15. Ko6.....Key Output 6
- 16. Ko5.....Key Output 5
- 17. Ko4.....Key Output 4
- 18. Ko3.....Key Output 3
- 19. Ko2.....Key Output 2
- 20. Ko1.....Key Output 1
- 21. Ko0.....Key Output 0
- 22. CCSCustom Code Select Input
- 23. Ki0.....Key Input 0
- 24. Ki1.....Key Input 1

• Absolute Max. Ratings (T_a = 25°C)

Item	Symbol	Limite	Unit
Supply voltage	V _{DD} - V _{SS}	4.0	V
Input voltage	V _{IN} - V _{SS}	-0.3 ~ V _{DD}	V
Output voltage	I _{OH} (REM, LMP)	-15.0	mA
Power dissipation	P _d	250	mW
Operating temperature	T _{opt}	-20 ~ +75	°C
Retention temperature	T _{stg}	-40 ~ +125	°C

- Recommended Operating Range

Item	Symbol	Min.	Typ.	Max.	Unit
Supply voltage	V_{DD}	2.0	3.0	3.3	V
Oscillation frequency	f_{OSC}	400	455	500	kHz
Indicator lamp output current	I_{OL} (LMP)		1		mA

- Electrical Characteristics ($T_a = 25^\circ\text{C}$, $V_{DD} = 3.0\text{V}$)

Item	Symbol	Measuring Condition	Min.	Typ.	Max.	Unit
Supply current	I_{DD} (OP)	$f_{OSC} = 455\text{ kHz}$		0.1	1.0	mA
Supply current	I_{DD} (ST)	$f_{OSC} = \text{STOP}$			1	μA
High-level input voltage	V_{IH} (KI)		$0.7V_{DD}$		V_{DD}	V
Low-level input voltage	V_{IL} (KI)		0		$0.3V_{DD}$	V
Input pull-down resistance	R (KI)		150	300	600	$\text{k}\Omega$
Output voltage	I_{OH} (REM)	V_{OH} (REM) = 1.5V	-5	-13		mA
Low-level output voltage	V_{OL} (LMP)	$I_{OL} = 1.0\text{ mA}$		0.17	0.3	V

- The pulse position modulation system (PPM) is introduced as shown in Figure for remote-control infrared output waveforms to discriminate 1 from 0 with a duration between pulses. Each of custom codes and data codes consists of 8 bits. Inverted codes are also transmitted in the system to minimize misoperation.

- **Remote Output Waveform**

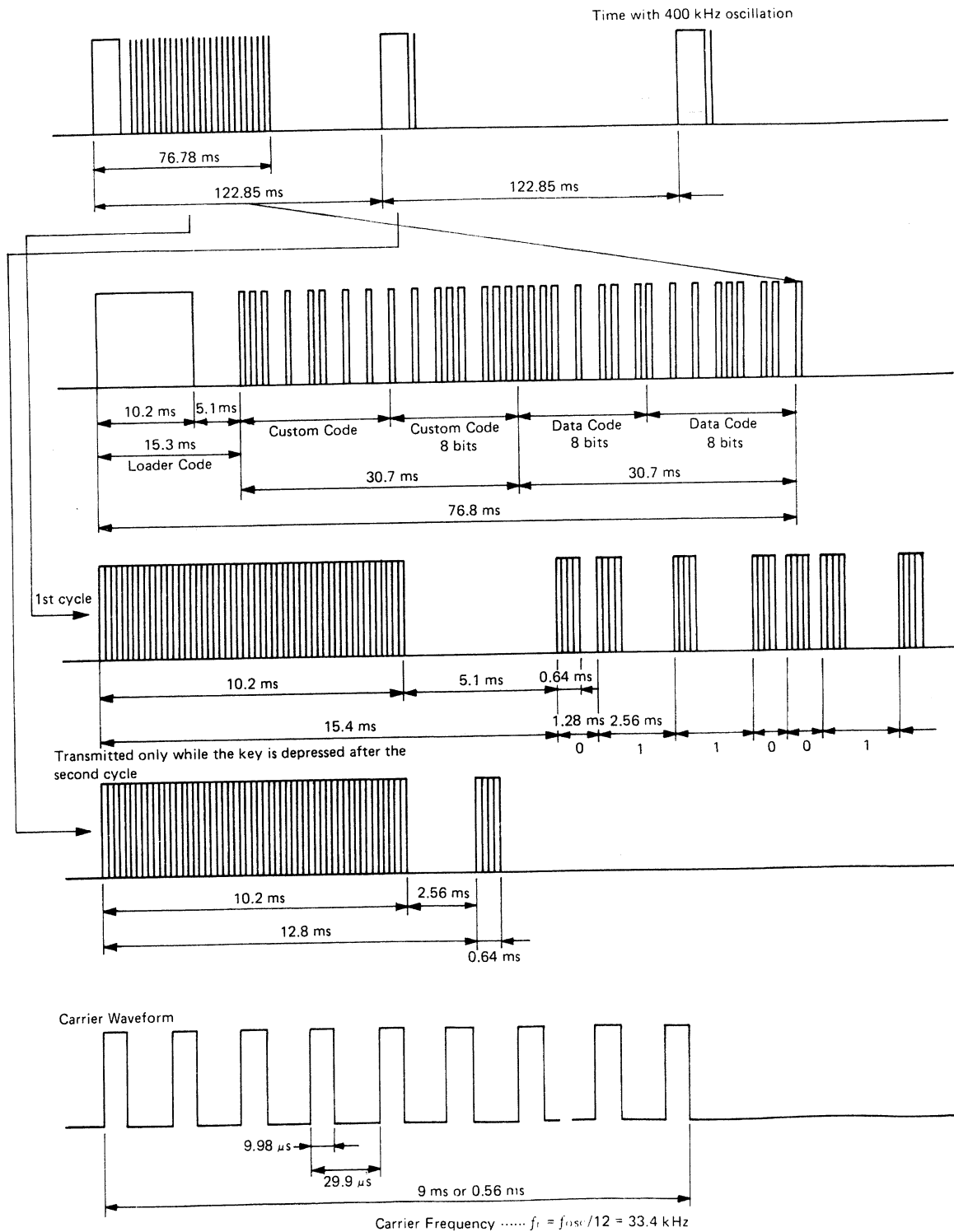

9-6. REMOTE CONTROLLER BLOCK DIAGRAM

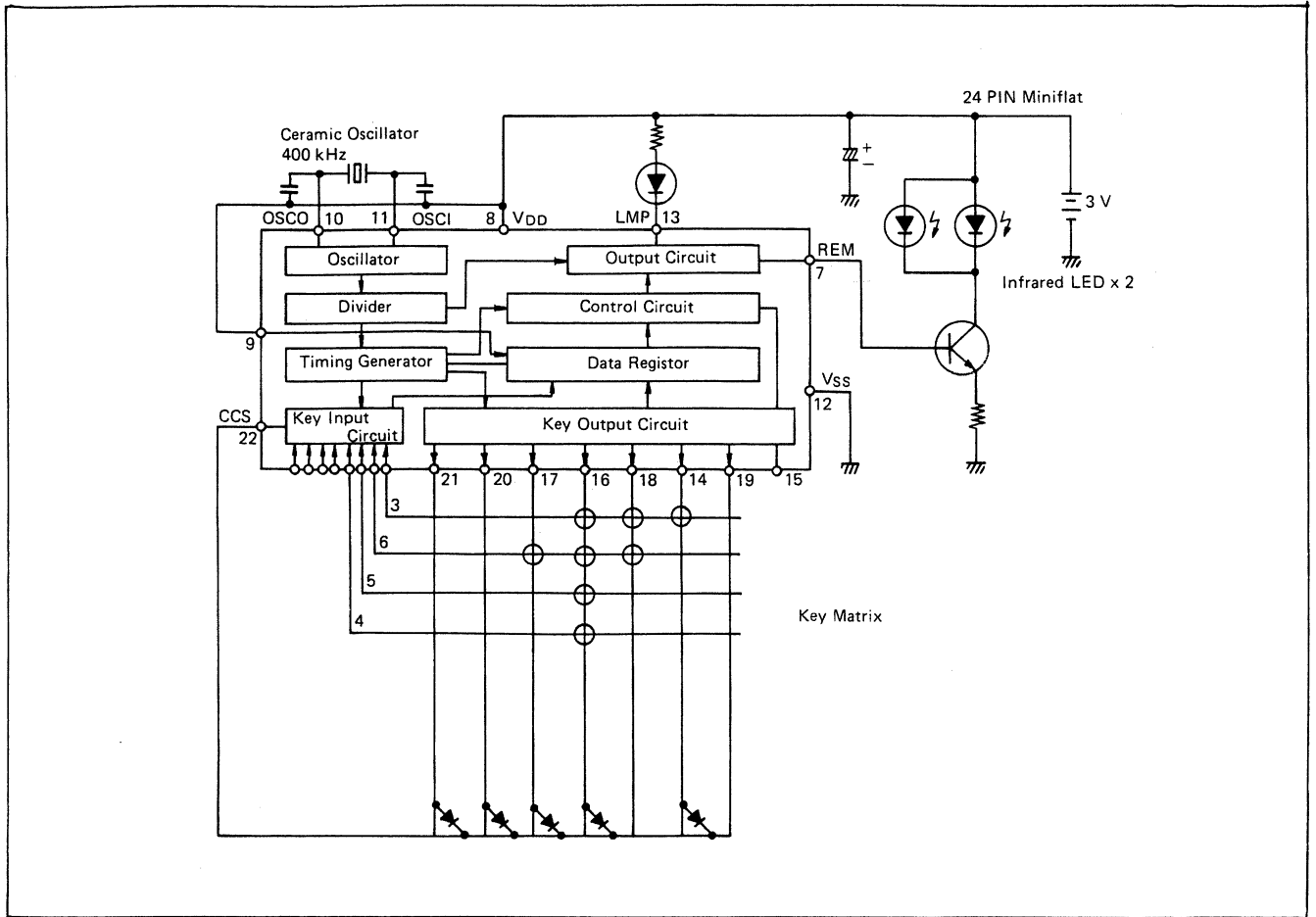

10. BLOCK DIAGRAM

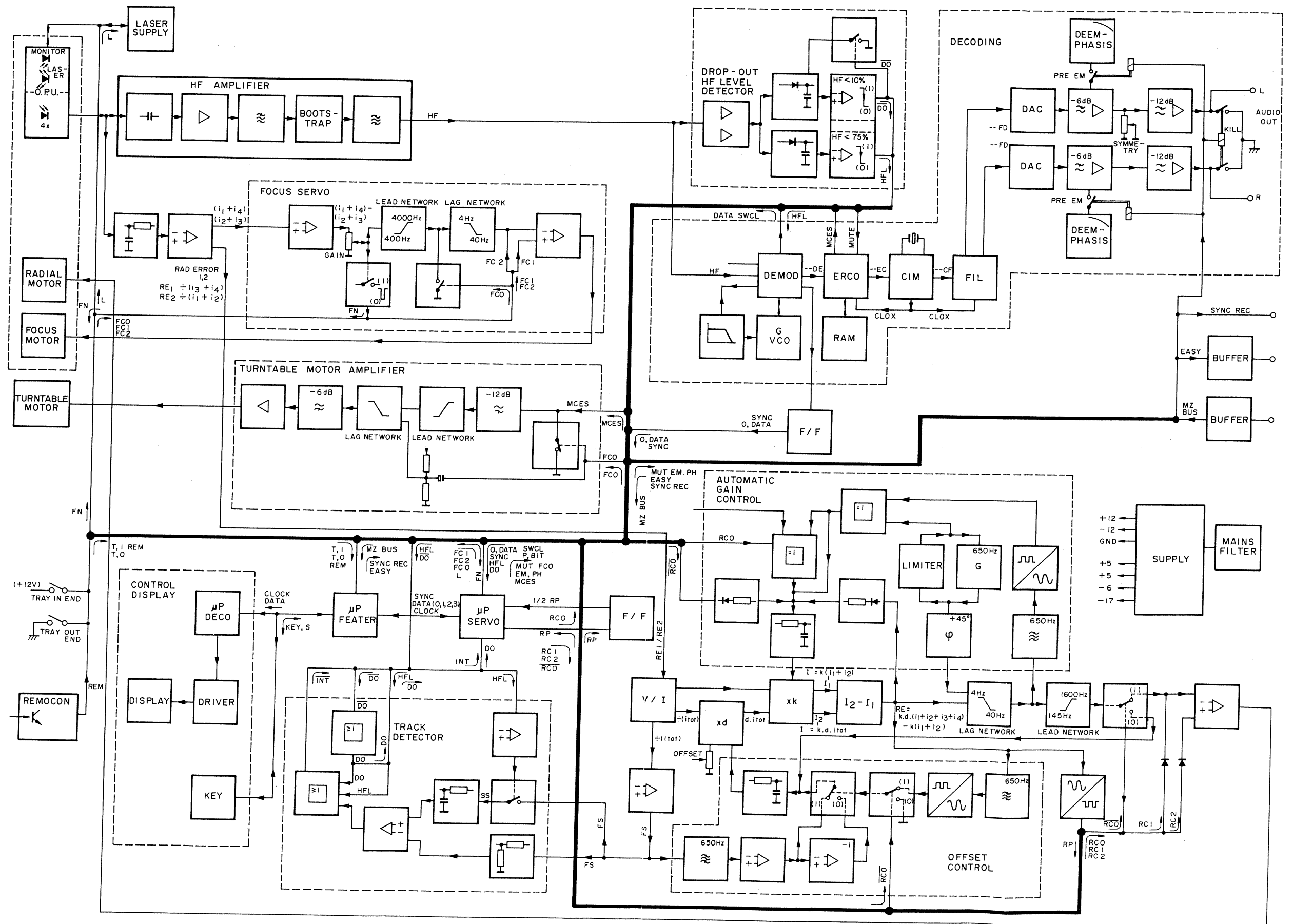

11. WIRING DIAGRAM

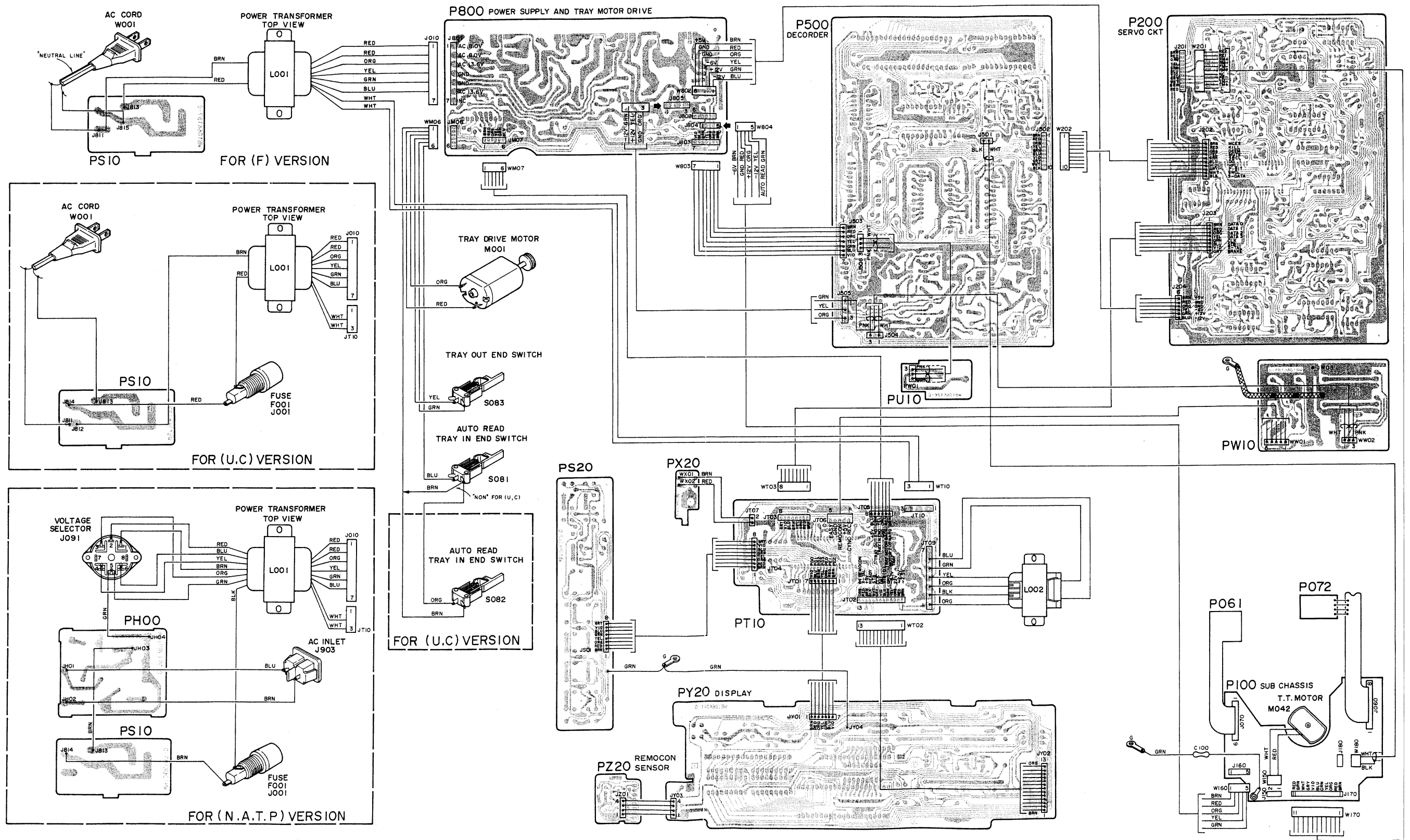

11. WIRING DIAGRAM

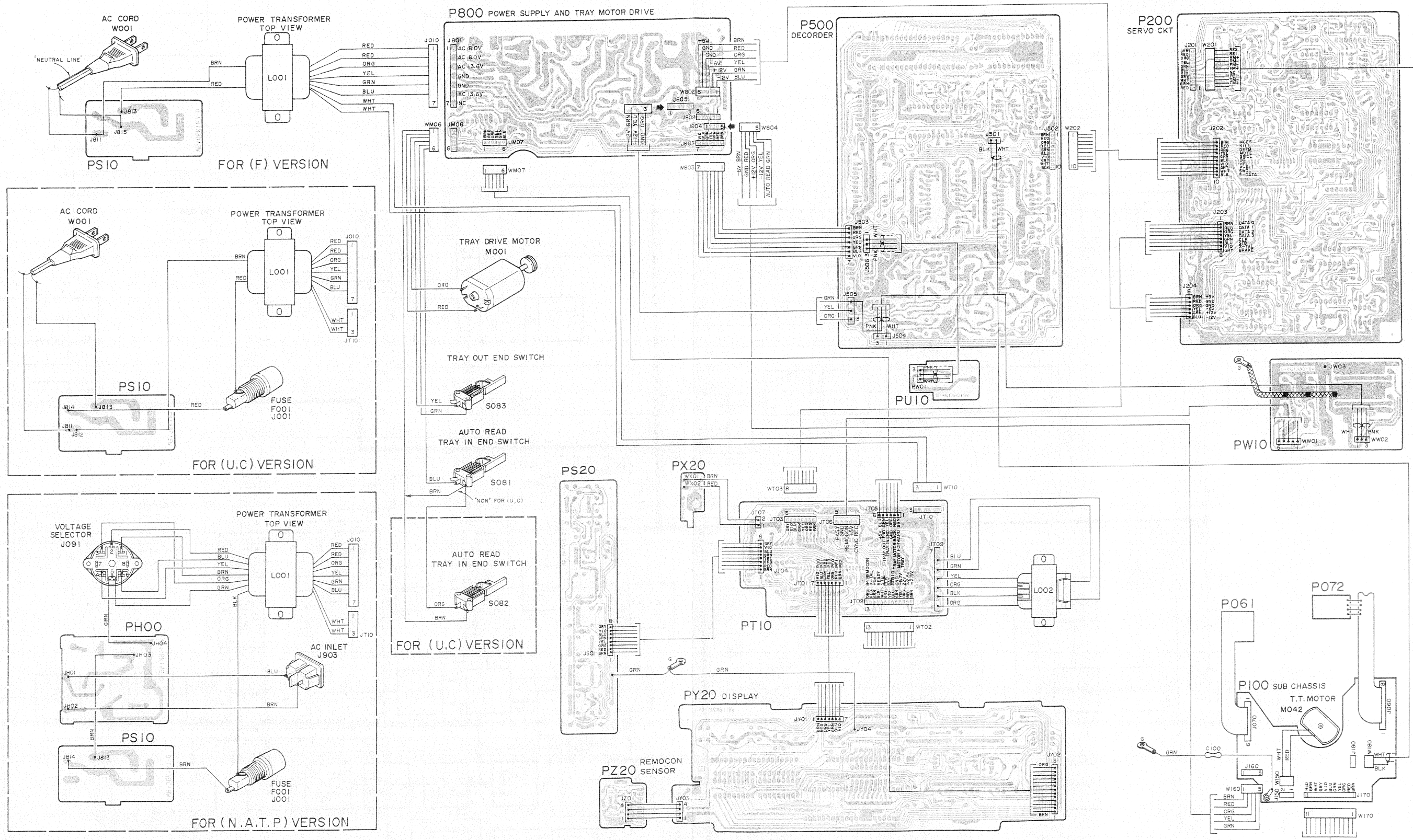

12. P.W. BOARD DIAGRAM

(P500) Decoder/Headphone Amp.

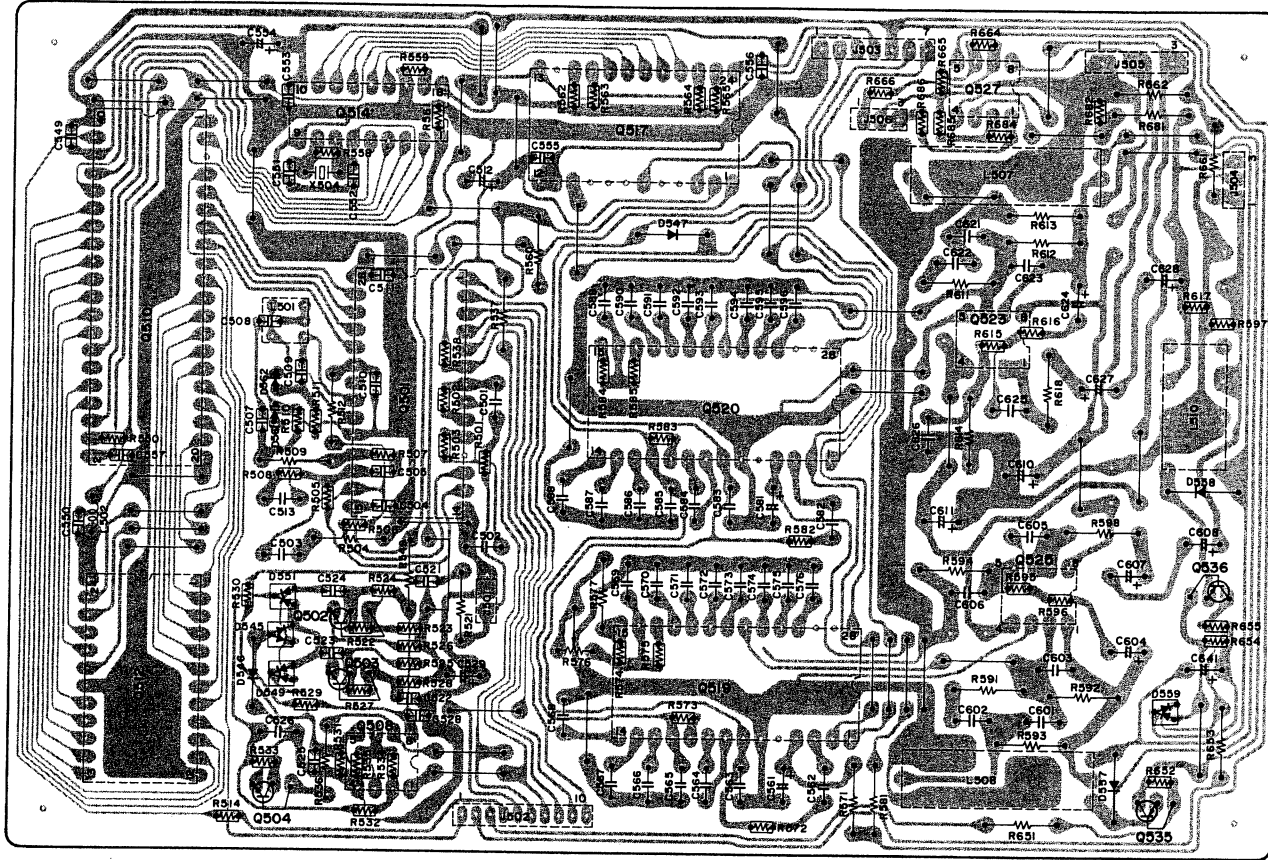

(PT10) Feather μ -com

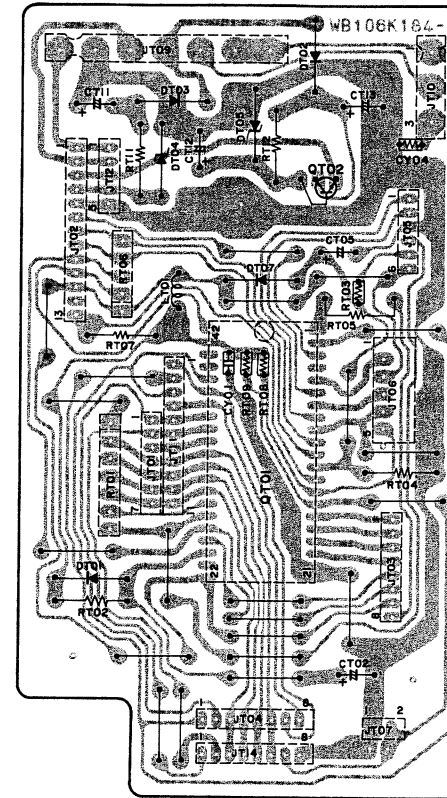

(PS20) Ten Key

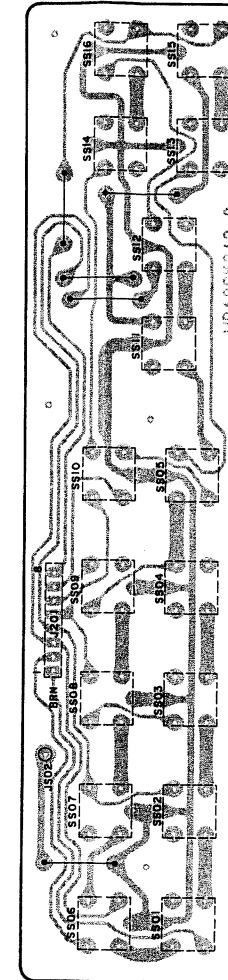

(PY20) Display

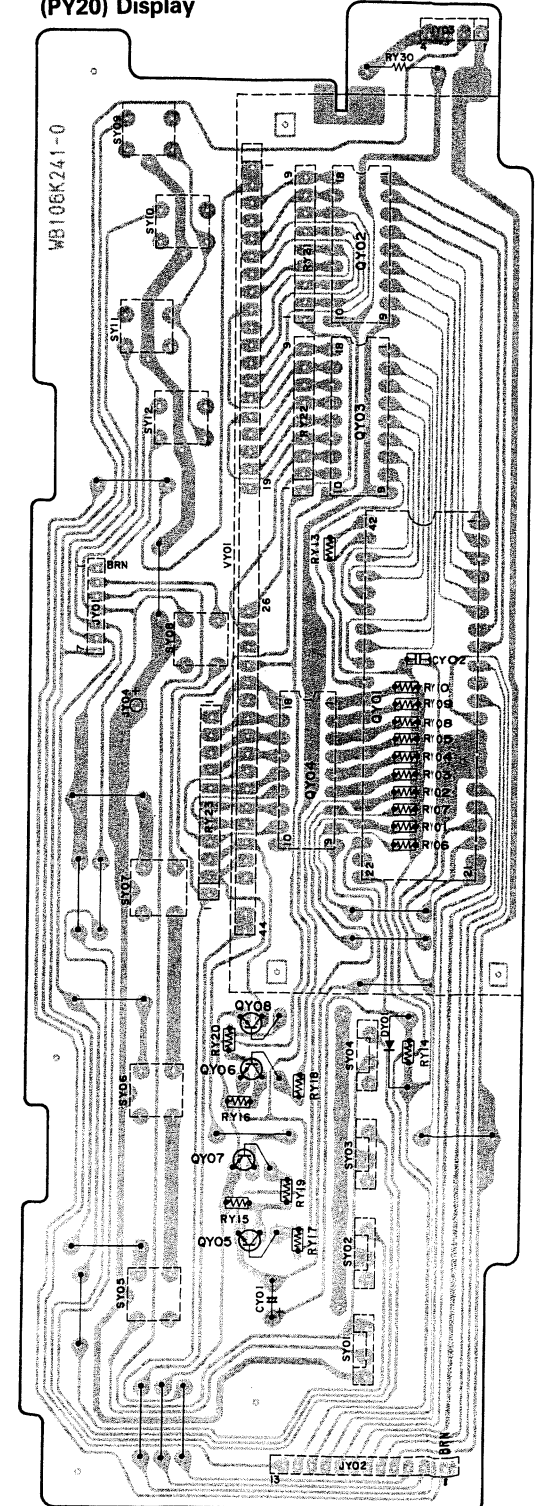

(P200) Servo

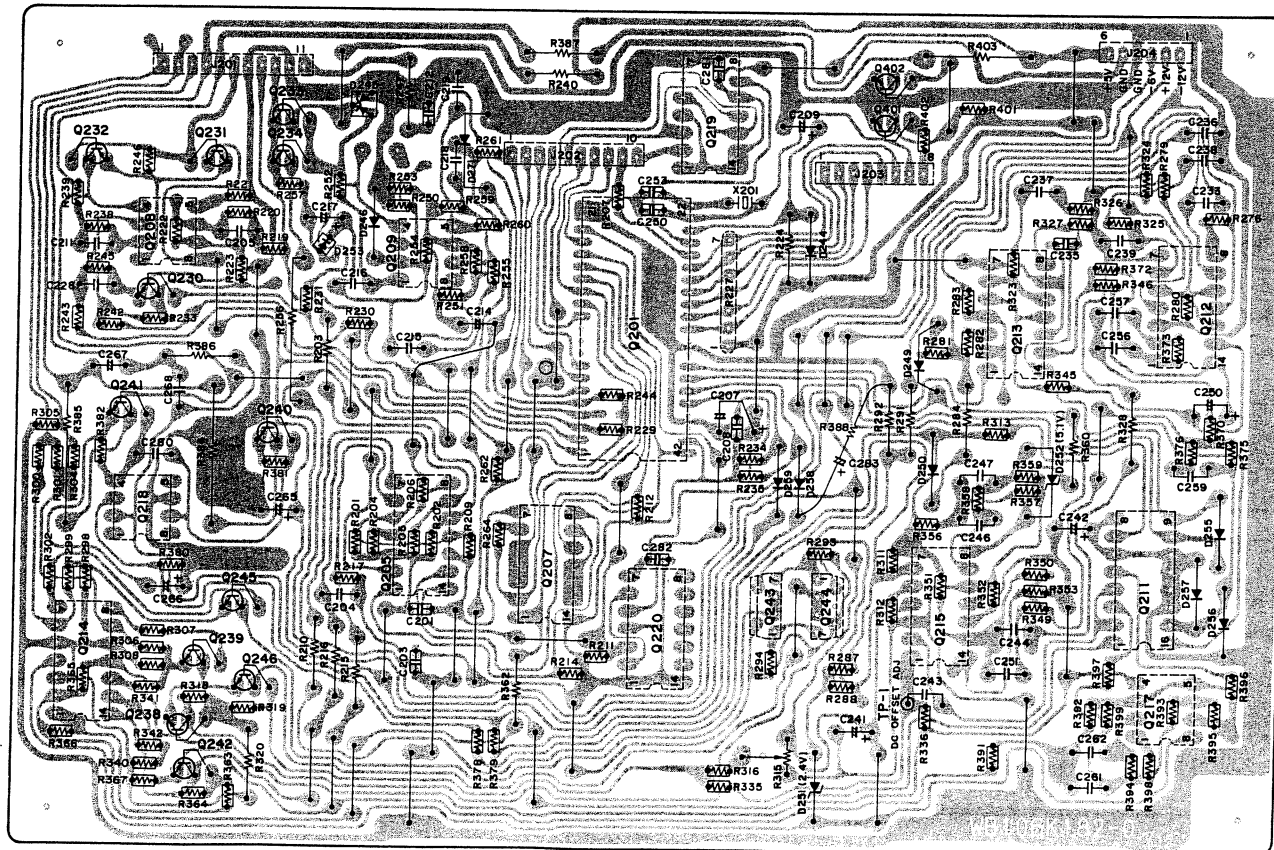

(PH00) Filter

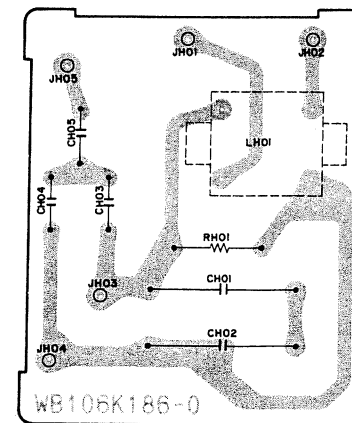

(PS10) Power Switch

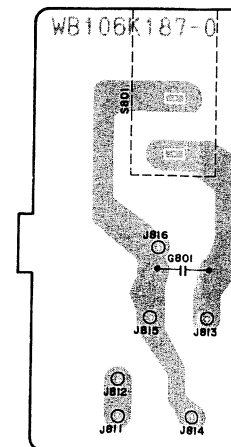

12. P.W. BOARD DIAGRAM

(P500) Decoder/Headphone Amp.

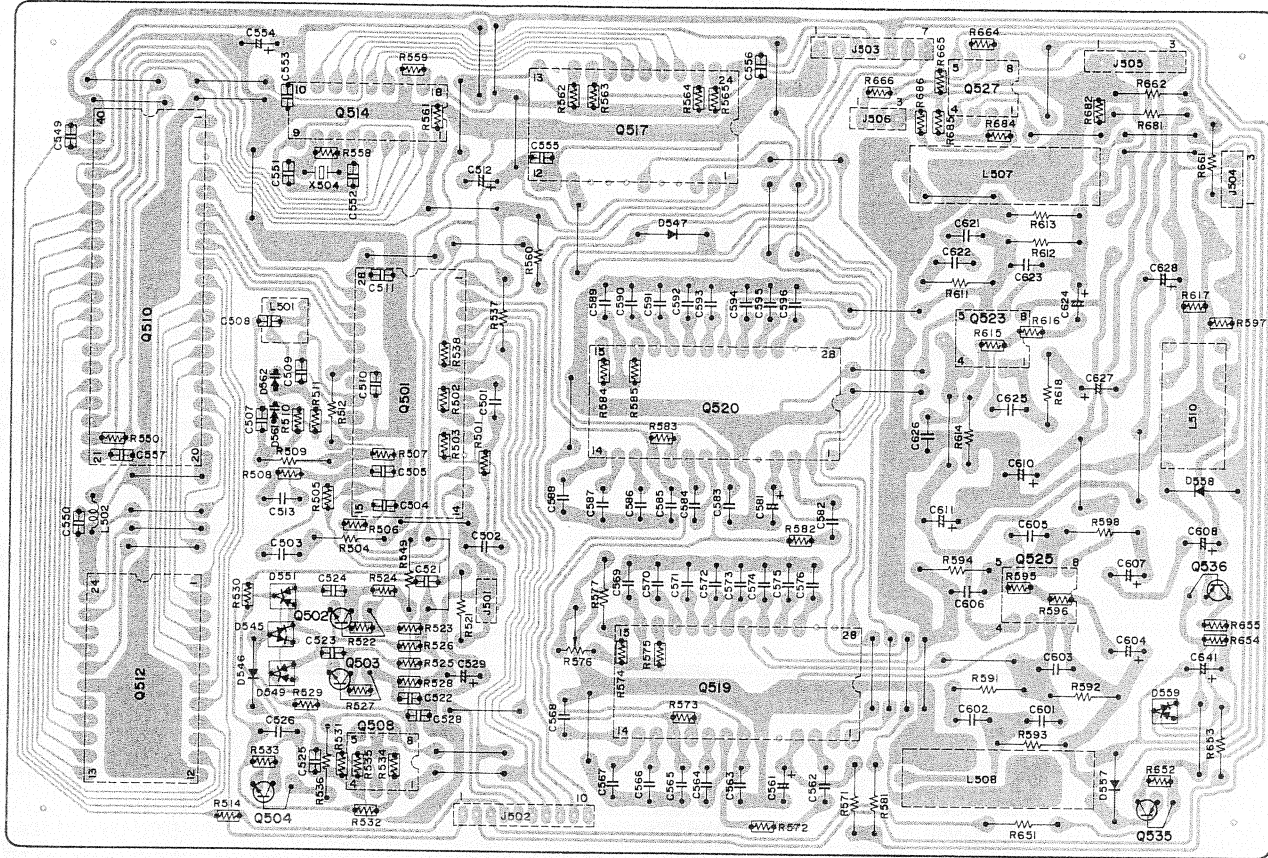

(PT10) Feater μ -com

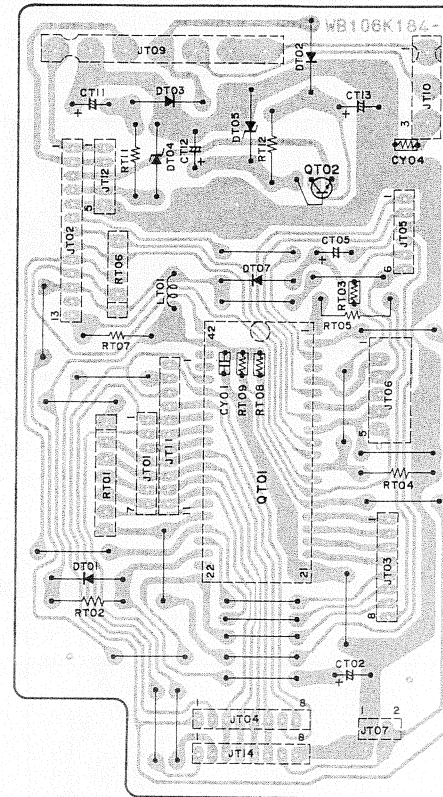

(PS20) Ten Key

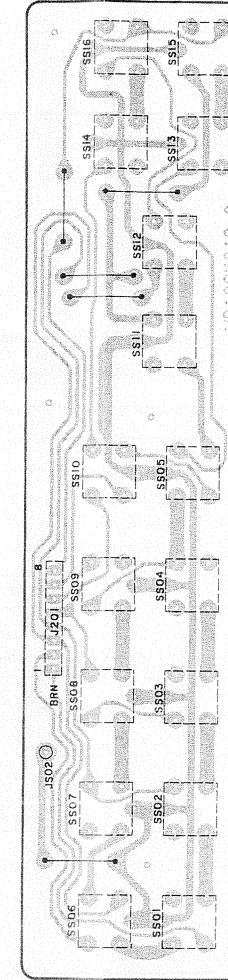

(PY20) Display

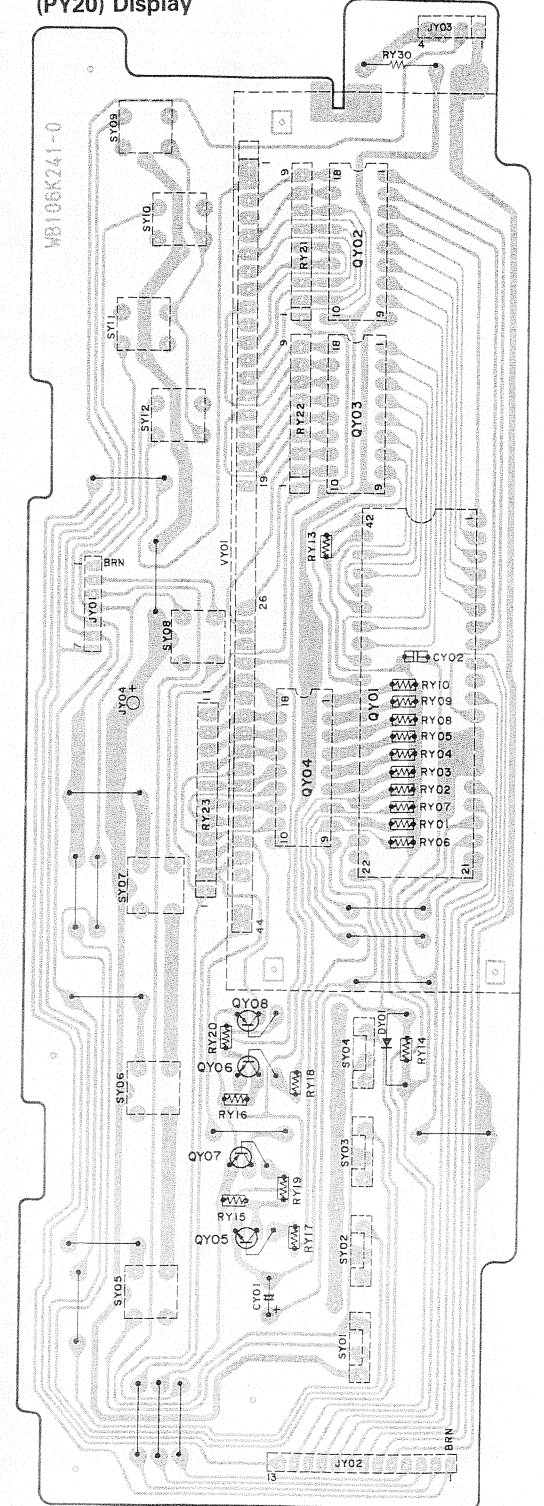

(P200) Servo

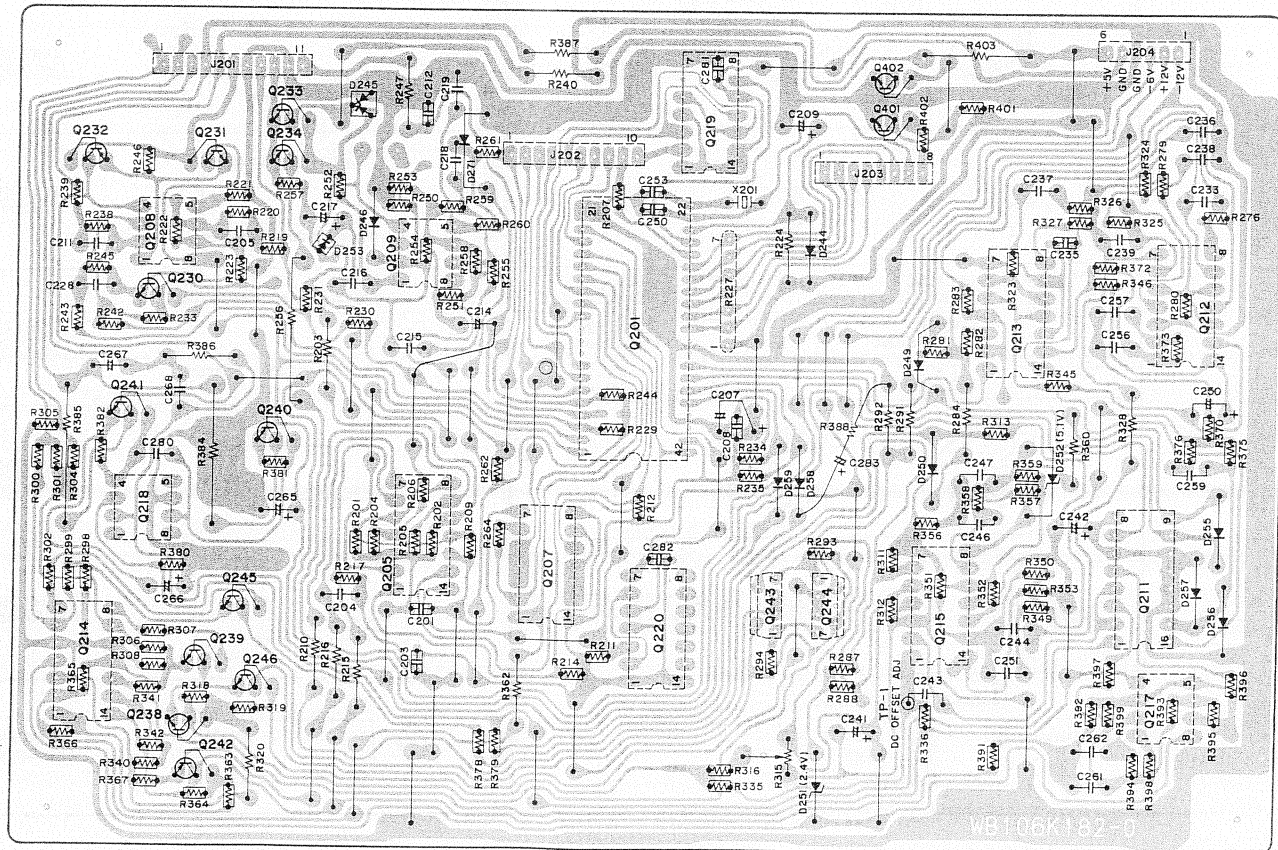

(PH00) Filter

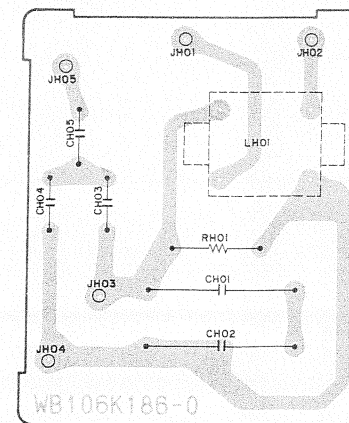

(PS10) Power Switch

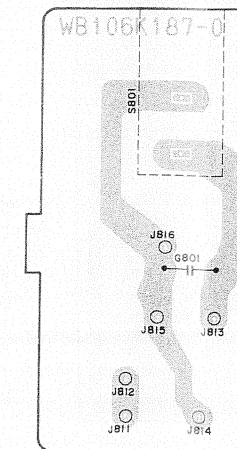

(P800) Power Supply

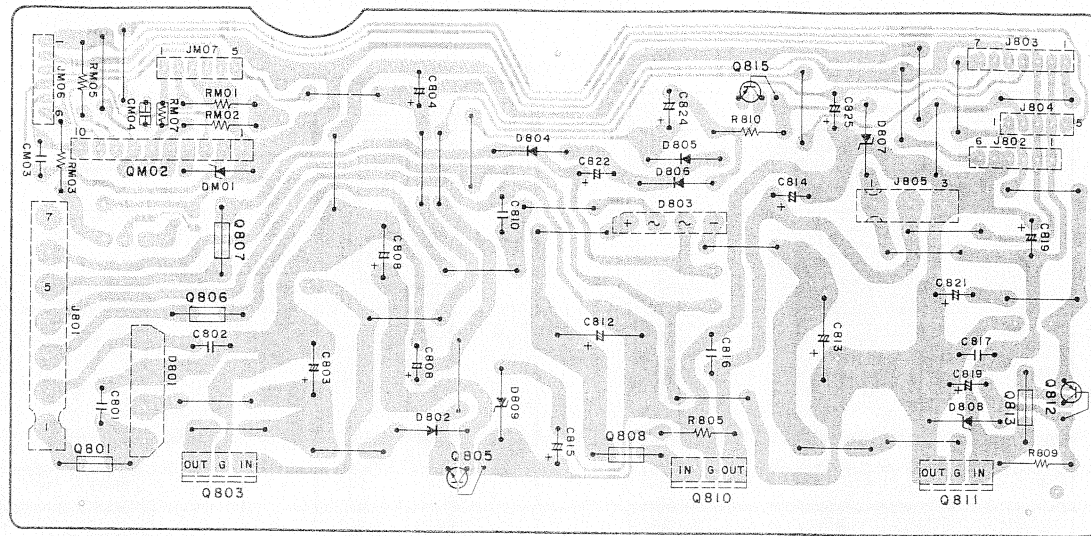

(PZ20) Sensor

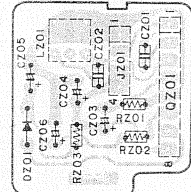

(PX20) In/Out

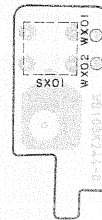

(PU10) Headphone Jack



(PW10) RCA Output Pin

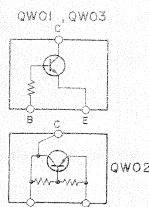
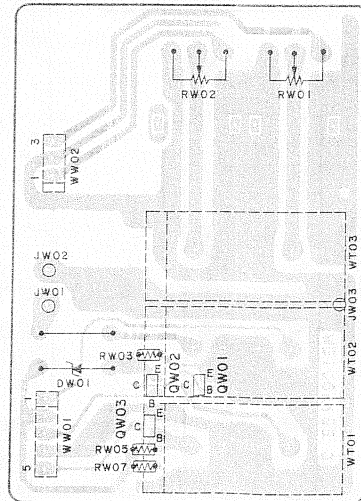

13. SEMICONDUCTORS ELECTRODES

<p>2SC945(PorQ) (HT30945280)</p> <p>2SA733(PorQ) (HT107332A0)</p>	FRONT VIEW	<p>L81645N (HC10148030)</p>
<p>2SC1383(R,S) (HT313832C0)</p> <p>2SA684(R) (HT106841R0)</p>	SIDE VIEW	<p>μPC1373H (HC10071060)</p>
<p>2SC2824(Y) (HT328241Y0)</p> <p>2SA1184(Y) (HT111841Y0)</p> <p>2SB632K(F) (HT206321F0)</p> <p>2SC1568 (HT315682A0)</p>	TOP VIEW	<p>μPC324C (HC10082060)</p>
	TOP VIEW	<p>HD14070B (HC10057010)</p> <p>HD74LS74A (HC10058010)</p>
<p>μPC7805H (HC10056060)</p> <p>μPC7812H (HC10043060)</p>	TOP VIEW	<p>SAA7011 (HC10022270)</p>
<p>μPC7912H (HC10044060)</p>	TOP VIEW	<p>SAA7020 (HC10023270)</p>
<p>MA151WK (HZ2000102Z)</p> <p>MA151WA (HZ20002020)</p>	TOP VIEW	<p>SAA7030 (HC10024270)</p>
<p>UN2114 PNP (BA1000102Z)</p>	TOP VIEW	<p>SAA7000 (HC10021270)</p>
<p>UN2215 NPN (BA2000102Z)</p>	TOP VIEW	<p>μPD4016C (HC10098060)</p>
<p>μPC339C (HC10081060)</p> <p>μPC741C (HC10083060)</p> <p>μPC393C (HC10084060)</p> <p>NJM2904D (HC10030090)</p> <p>NJM4558D (HC10003090)</p> <p>JRC4560DD (HC10021090)</p>	TOP VIEW	<p>TDA1540D (HC10025270)</p>
<p>2SC3381 G.R. (HT333811G0)</p>	TOP VIEW	<p>HD14053B (HC10056010)</p>
<p>2SC2785(J or H) (HT327852A1)</p> <p>2SA1175(RF, JF) (HT111752A1)</p>	TOP VIEW	<p>HD14025B (HC10055010)</p>
<p>μPD1510AC (HC10106060)</p>	TOP VIEW	<p>MSL918RS (HC10004260)</p>

(P800) Power Supply

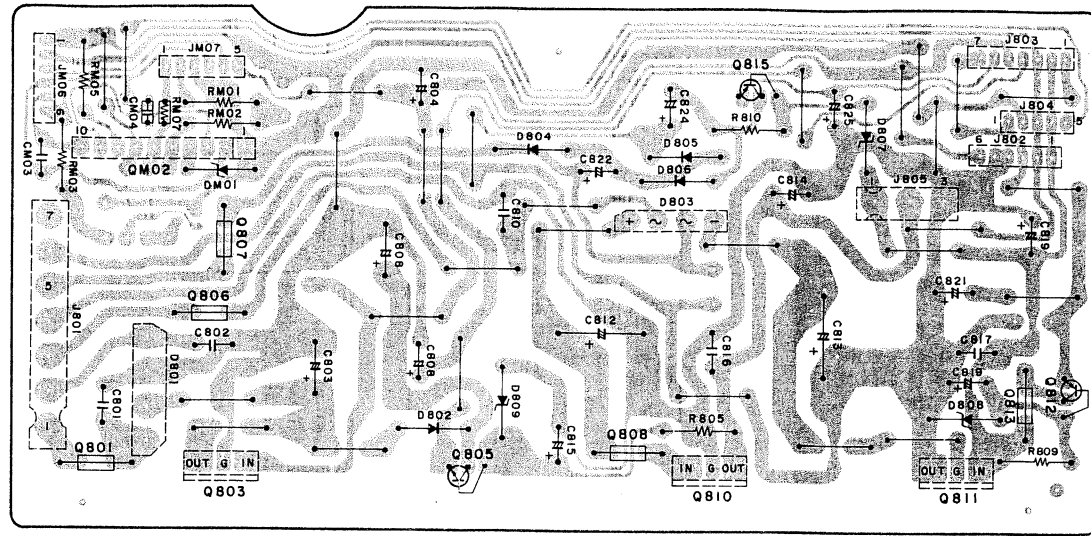

(PZ20) Sensor

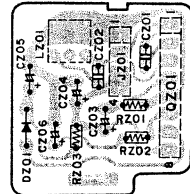

(PX20) In/Out

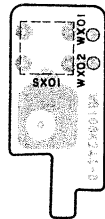

(PU10) Headphone Jack

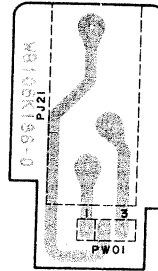

(PW10) RCA Output Pin

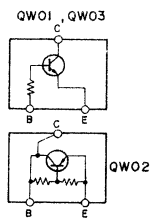
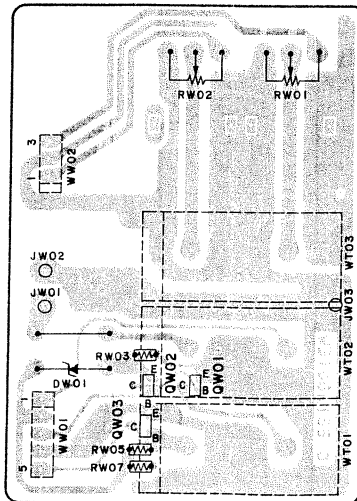

13. SEMICONDUCTORS ELECTRODES

	<p>2SC945(PorQ) (HT30945280)</p> <p>2SA733(PorQ) (HT107332A0)</p>	<p>FRONT VIEW</p>	<p>LB1645N (HC10148030)</p>
	<p>2SC1383(R,S) (HT313832C0)</p> <p>2SA684(R) (HT106841R0)</p>	<p>SIDE VIEW</p>	<p>μPC1373H (HC10071060)</p>
	<p>2SC2824(Y) (HT328241Y0)</p> <p>2SA1184(Y) (HT111841Y0)</p>	<p>TOP VIEW</p>	<p>μPC324C (HC10082060)</p>
	<p>2SB632K(F) (HT206321F0)</p> <p>2SC1568 (HT315682A0)</p>	<p>TOP VIEW</p>	<p>HD14070B (HC10057010)</p> <p>HD74LS74A (HC10058010)</p>
	<p>μPC7805H (HC10056060)</p> <p>μPC7812H (HC10043060)</p>	<p>TOP VIEW</p>	<p>SAA7011 (HC10022270)</p>
	<p>μPC7912H (HC10044060)</p>	<p>TOP VIEW</p>	<p>SAA7020 (HC10023270)</p>
	<p>MA151WK (HZ2000102Z)</p> <p>MA151WA (HZ20002020)</p>	<p>TOP VIEW</p>	<p>SAA7030 (HC10024270)</p>
	<p>UN2114 PNP (BA1000102Z)</p>	<p>TOP VIEW</p>	<p>SAA7000 (HC10021270)</p>
	<p>UN2215 NPN (BA2000102Z)</p>	<p>TOP VIEW</p>	<p>μPD4016C (HC10098060)</p>
<p>TOP VIEW</p>	<p>μPC339C (HC10081060)</p> <p>μPC741C (HC10083060)</p> <p>μPC393C (HC10084060)</p>	<p>TOP VIEW</p>	<p>NJM2904D (HC10030090)</p> <p>NJM4558D (HC10003090)</p> <p>JRC4560DD (HC10021090)</p>
	<p>2SC3381 G.R. (HT333811G0)</p>	<p>TOP VIEW</p>	<p>HD14053B (HC10056010)</p>
	<p>2SC2785(J or H) (HT327852A1)</p> <p>2SA1175(RF, JF) (HT111752A1)</p>	<p>TOP VIEW</p>	<p>HD14025B (HC10055010)</p>
<p>TOP VIEW</p>	<p>μPD1510AC (HC10106060)</p>	<p>TOP VIEW</p>	<p>MSL918RS (HC10004260)</p>

14. SCHEMATIC DIAGRAM

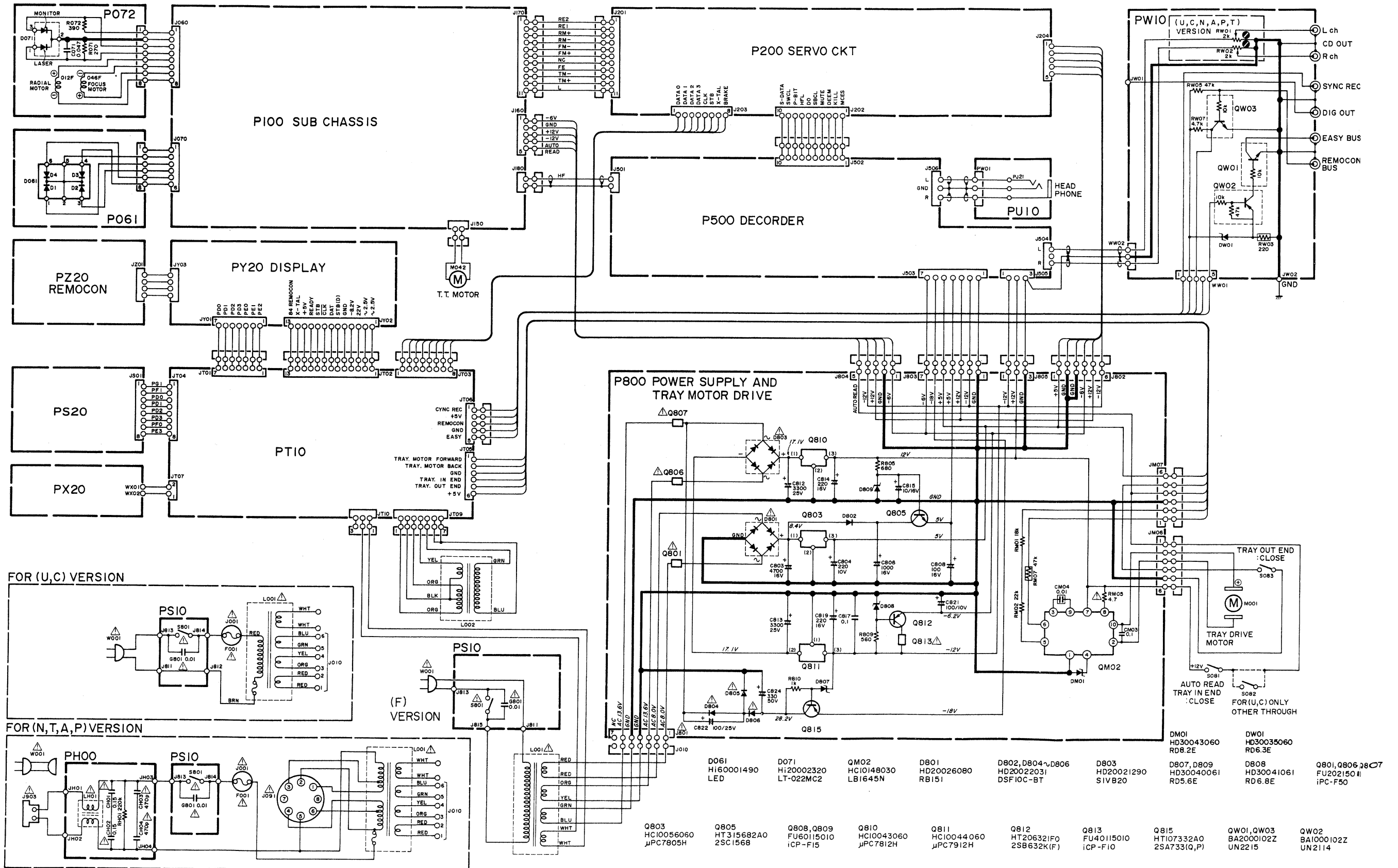

D244, D246, D249
D250, D255~D259
HD20001001
IS2473, IS1555
DS448, MA150

D245
HZ2000102Z
MA151WK

D251
HD30041010
HZ2C2

D252
HD30021061
RD5.1EB2

D253
HZ3000102Z
MA3068M

Q201
HC10105060
µCOM SERVO

Q205
HC10081060
µPC339C

Q207
HC10055010
HDI4025B

Q208, Q209, Q217
HC10003090
NJM4558D

Q211
HC10056010
HDI4053B

Q212, Q214, Q215
HC10082060
µPC324C

Q213
HC10057010
HDI4070B

Q218
HC10083060
µPC741C

Q219, Q220
HC10058010
HD74LS74A

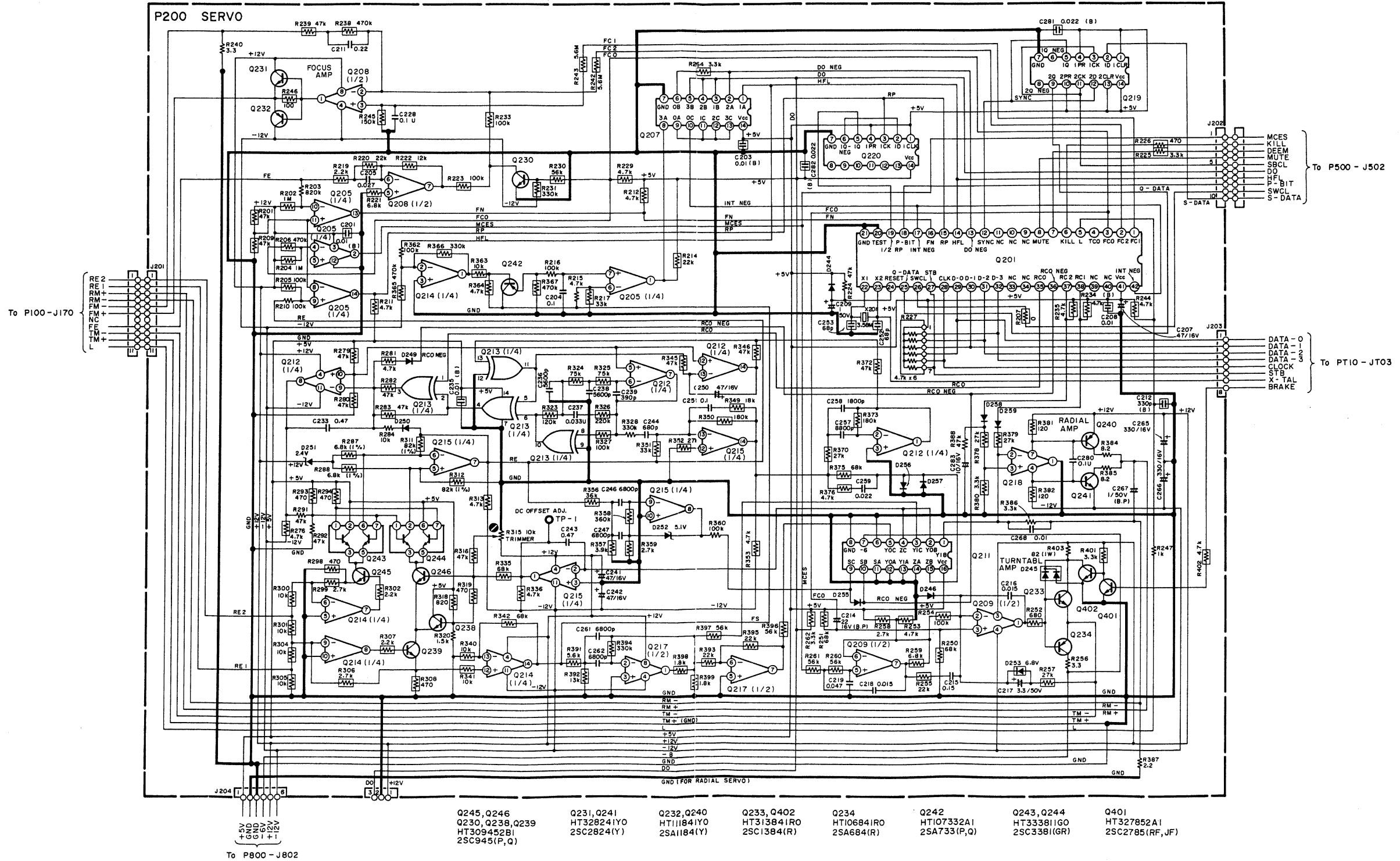

D545 HZ200020Z MAI51WA
 D546, D557, D558 HD2000121I IS2473
 D547 HD20001001 IS2473, IS1555, DS448, MAI50

To P200-J202
 S DATA
 SWCL
 P BIT
 HFL
 DO
 SBCL
 MUTE
 DEEM
 KILL
 MCES

D549, D551 HZ2000102Z MAI51WK

D559 HZ2000502Z MAI53

D561, D562 HD40006030 SVC321SP

Q501 HCl0022270 SAA7011

Q502-Q504 HT327852A1 25C2785(RF, JF)

Q508 HCl0084060 JPC393C

Q510 HCl0023270 SAA7020

Q512 HCl0098060 JPD4016C

Q514 HCl0021270 SAA7000

Q517 HCl0024270 SAA7030

Q519, Q520 HCl0025270 TDA1540D

Q523, Q525, Q527 HCl0021090 JRC4560DD

Q535, Q536 HT11752A1 25A1175(RF, JF)

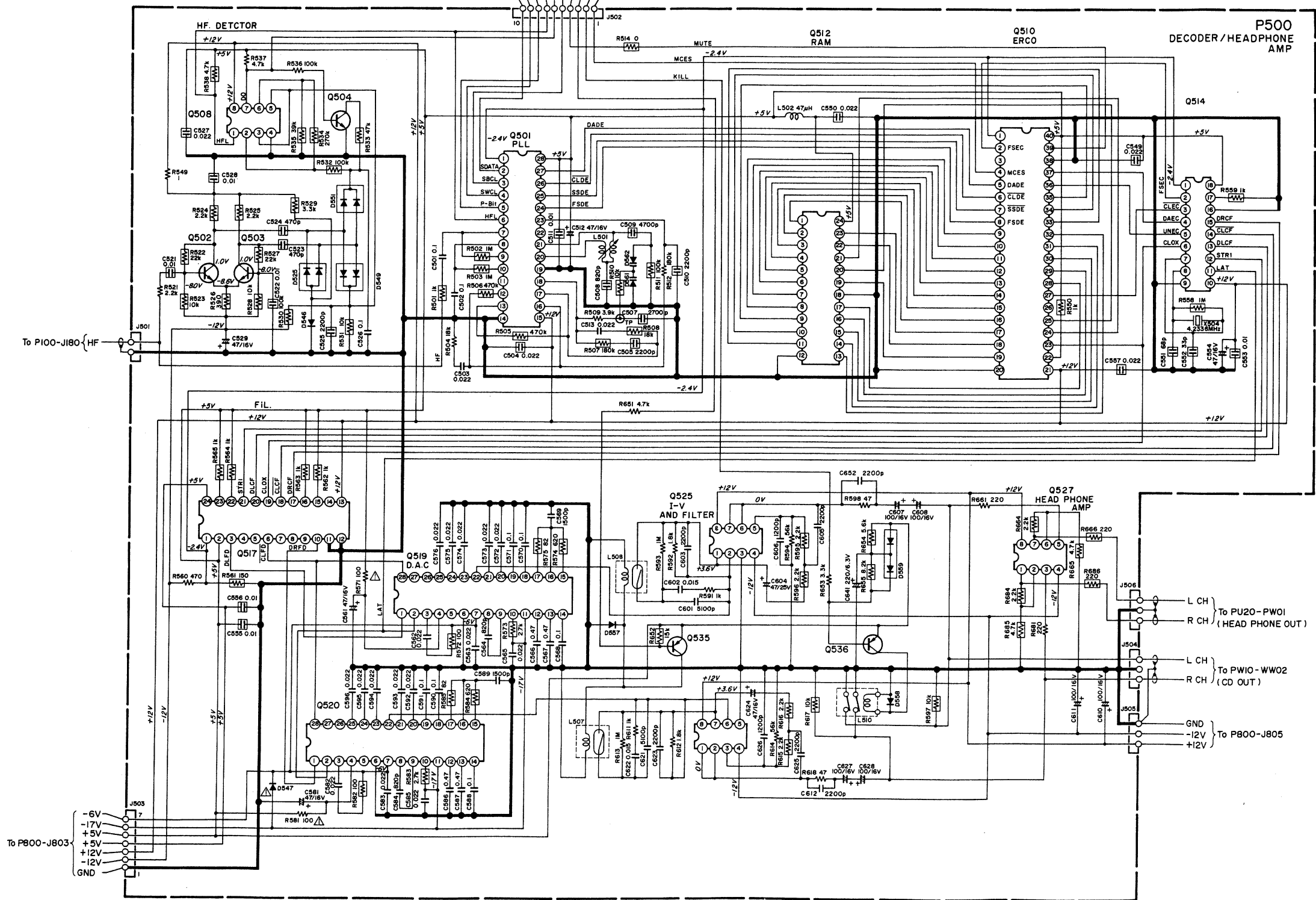

QY01 HC10106060 μPDI510AC
 QY02~QY04 HC10004260 MSL918RS
 QY05, QY06 HT327852A1 2SC2785(RF, JF)
 QY07, QY08 HT111752A1 2SA1175(RF, JF)
 QZ01 HC10071060 μPCI373H
 QT01 HC10104060 μPDI512ACU
 QT02 HT313842A0 2SC1384
 DT01 HD20001001 IS2473, IS1555 DS448, MA150
 DT02 HD20022031 DSF10C
 DT04 HD30043061 RDB.2E
 DT05 HD30022061 RD22E
 DT07 HD20001001 IS2473, IS1555
 DZ01 HI60001060 PH302

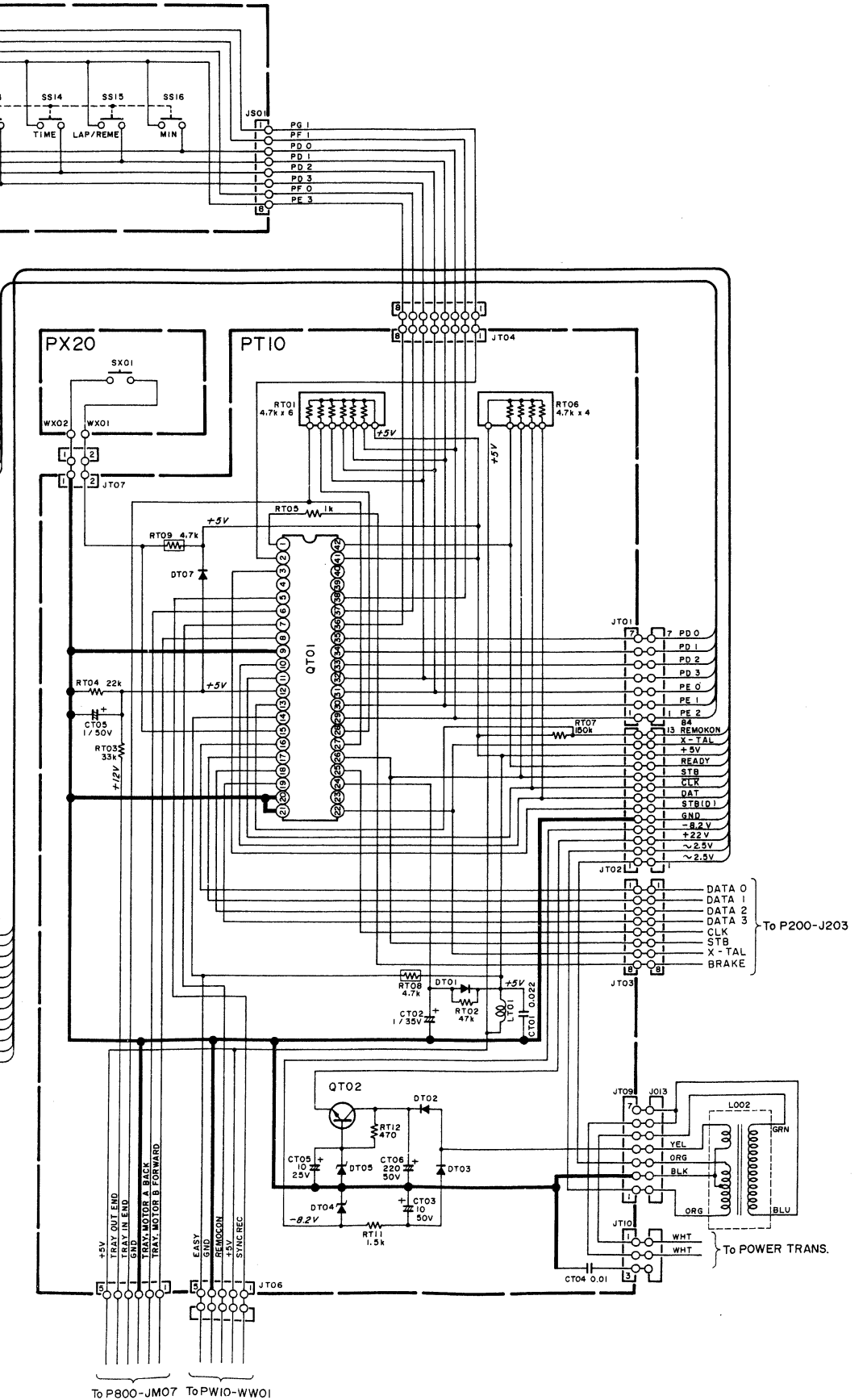
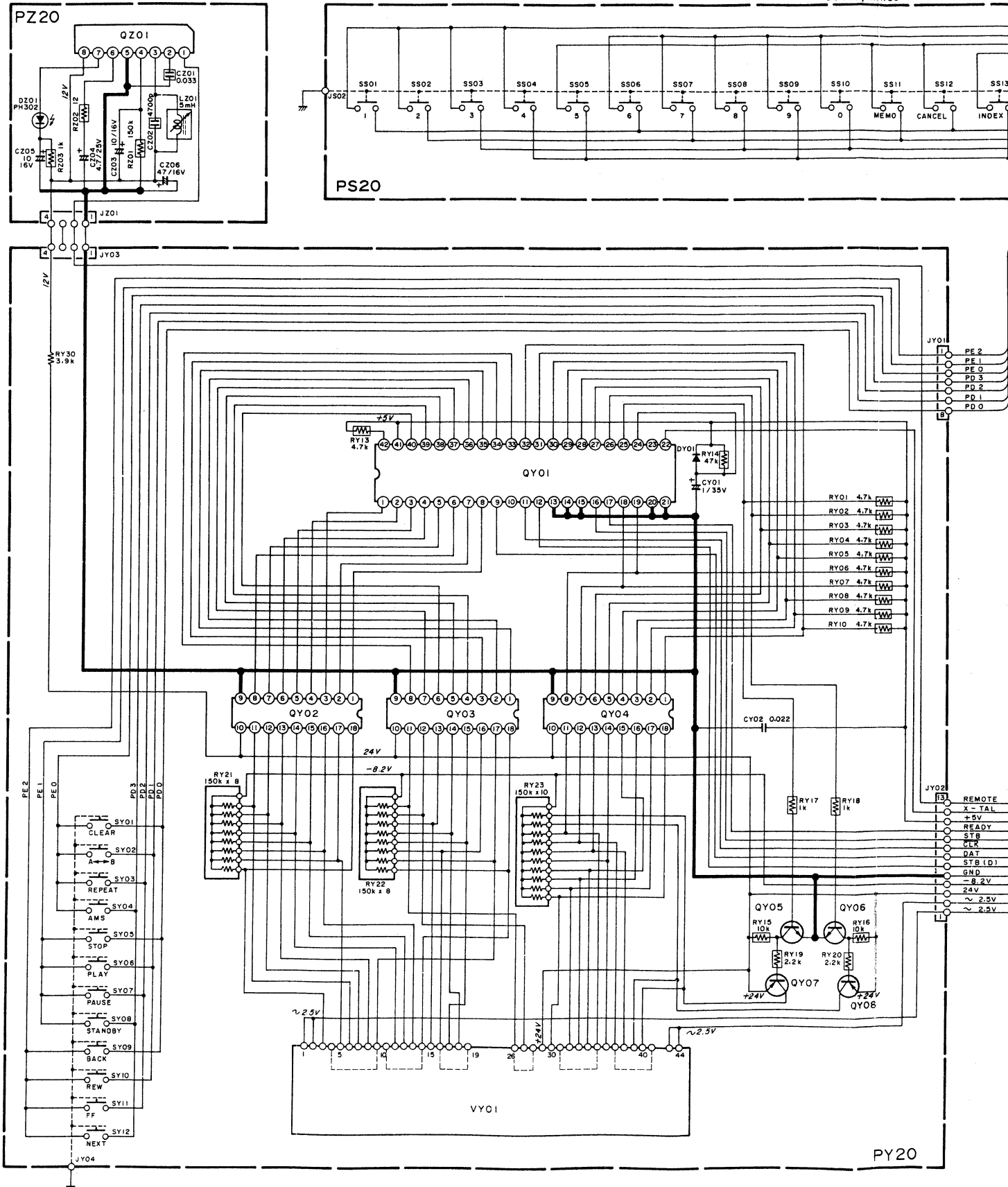

15. REMOTE CONTROLLER (RMC-84) WIRING DIAGRAM AND SCHEMATIC DIAGRAM

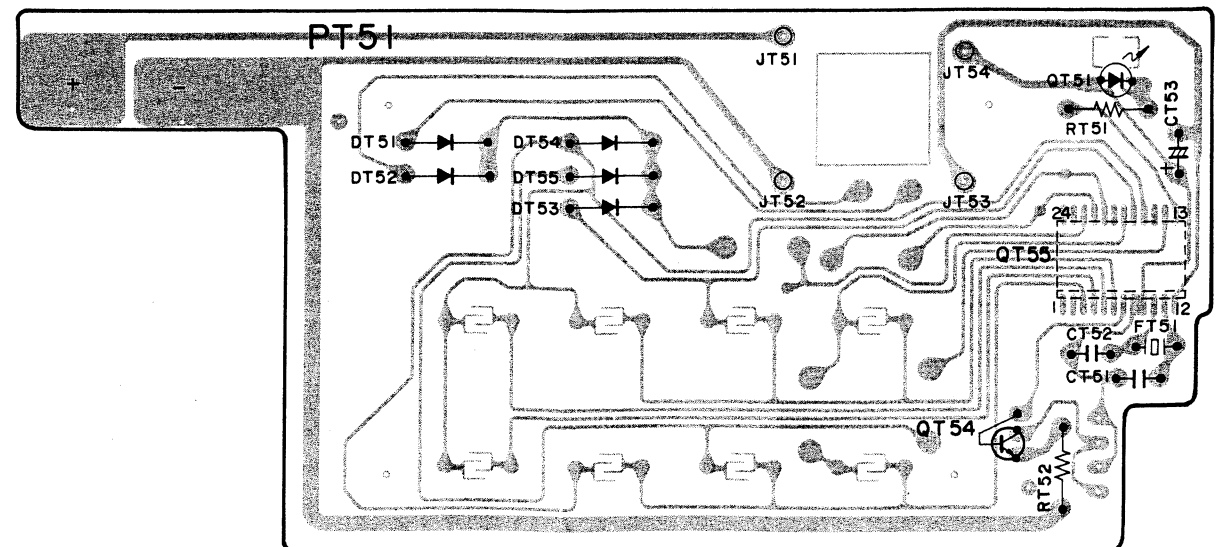
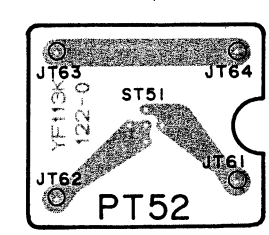
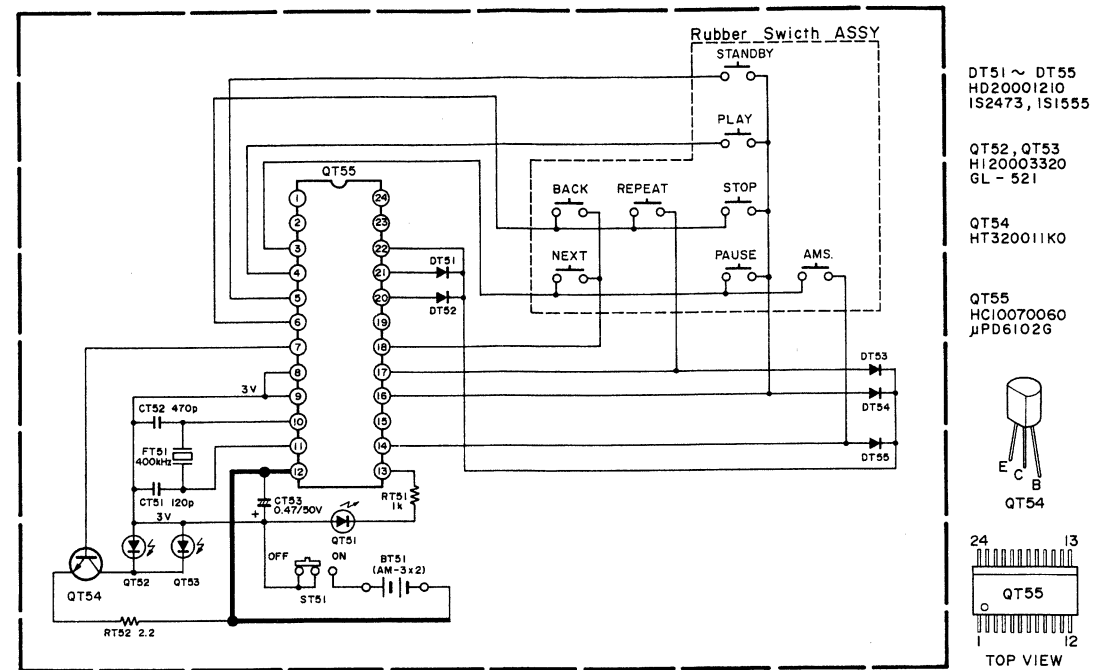
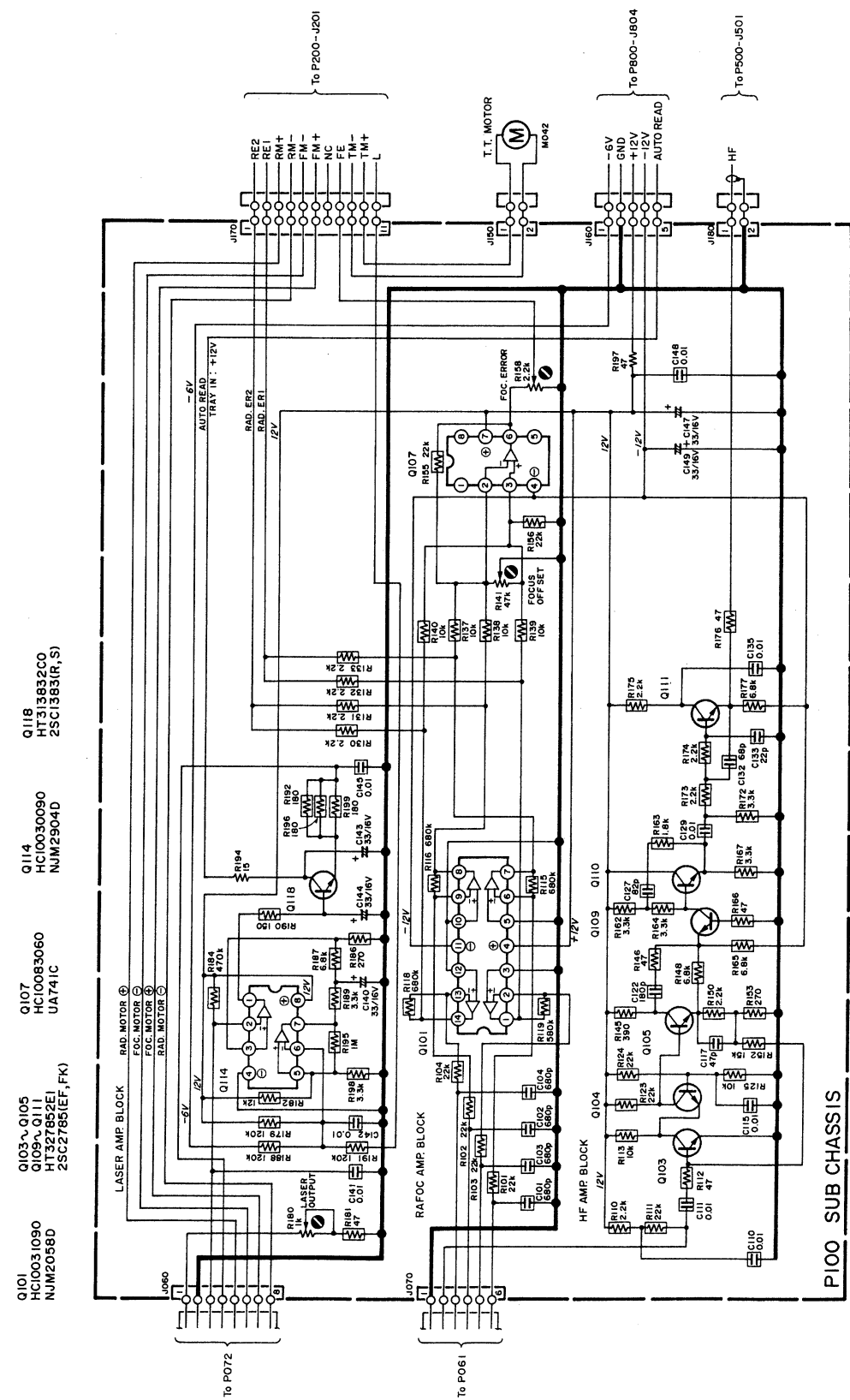

16. EXPLODED VIEWS AND PARTS LIST

[C01-99] FRONT PANEL

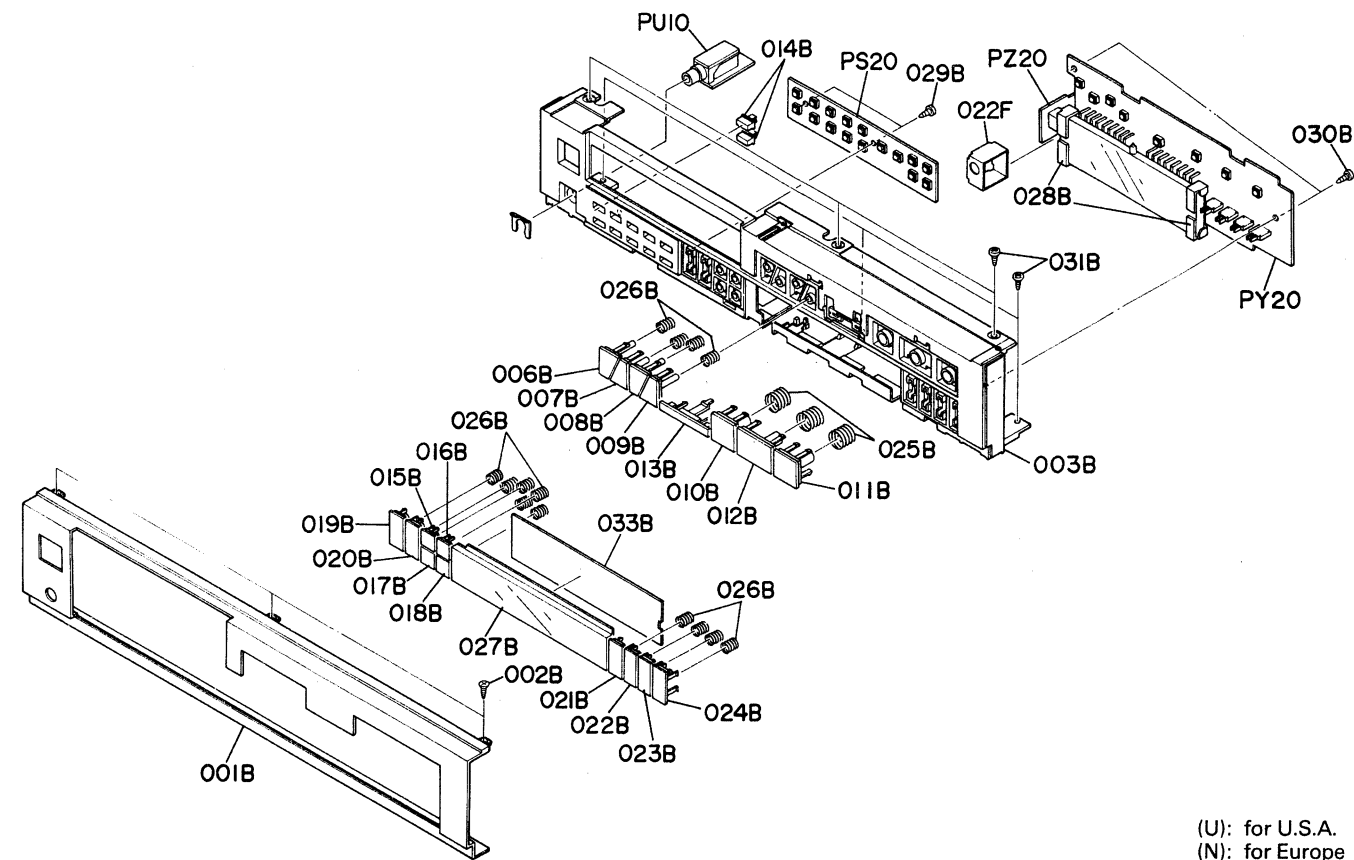

(U): for U.S.A.
 (N): for Europe
 (A): for Australia
 (P): for P.X.
 (F): for Japan

REF. DESIG.	Q'TY					PART NO.	DESCRIPTION
	U	N	A	P	F		
001B	1	1	1	1	1	106K248010	Panel, Front
001B						106K248050	Panel, Front (BLK)
002B	3	3	3	3	3	51500306B0	F.H. Tapped Screw F3 x 6
003B	1	1	1	1	1	106K248020	Sub Panel, Front
003B						106K248060	Sub Panel, Front
006B	1	1	1	1	1	106K270050	Button, Back
006B						106K270260	Button, Back
007B	1	1	1	1	1	106K270200	Button, REW
007B						106K270270	Button, REW
008B	1	1	1	1	1	106K270210	Button, FF
008B						106K270280	Button, FF
009B	1	1	1	1	1	106K270220	Button, Next
009B						106K270290	Button, Next
010B	1	1	1	1	1	106K270060	Button, Pause
010B						106K270300	Button, Pause
011B	1	1	1	1	1	106K270230	Button, Stop
011B						106K270310	Button, Stop
012B	1	1	1	1	1	106K270070	Button, Play
012B						106K270320	Button, Play
013B	1	1	1	1	1	106K270080	Button, Standby
013B						106K270330	Button, Standby
014B	10	10	10	10	10	106K270030	Button, Ten-key
015B	1	1	1	1	1	106K270020	Button, Index
016B	1	1	1	1	1	106K270120	Button, Lap
017B	1	1	1	1	1	106K270130	Button, Time

REF. DESIG.	Q'TY					PART NO.	DESCRIPTION
	U	N	A	P	F		
018B	1	1	1	1	1	106K270140	Button, Min
019B	1	1	1	1	1	106K270040	Button, Memo
020B	1	1	1	1	1	106K270150	Button, Cancel
021B	1	1	1	1	1	106K270160	Button, AMS
022B	1	1	1	1	1	106K270170	Button, Repeat
023B	1	1	1	1	1	106K270180	Button, A & B
024B	1	1	1	1	1	106K270190	Button, Clear
025B	3	3	3	3	3	106K115020	Spring, (L)
026B	14	14	14	14	14	106K115030	Spring, (S)
027B	1	1	1	1	1	106K158010	Window
028B	2	2	2	2	2	106K271020	Holder, Digitron
029B	2	2	2	2	2	51280306B0	B.H. Tapped Screw B3 x 6
030B	2	2	2	2	2	51280306B0	B.H. Tapped Screw B3 x 6
031B	6	6	6	6	6	51280306B0	B.H. Tapped Screw B3 x 6
033B	1	1	1	1	1	106K303010	Mask, Display
022F	1	1	1	1	1	106K109040	Shield, Remocon

[C02-99] LID (Top/Bottom) & GENERAL PARTS

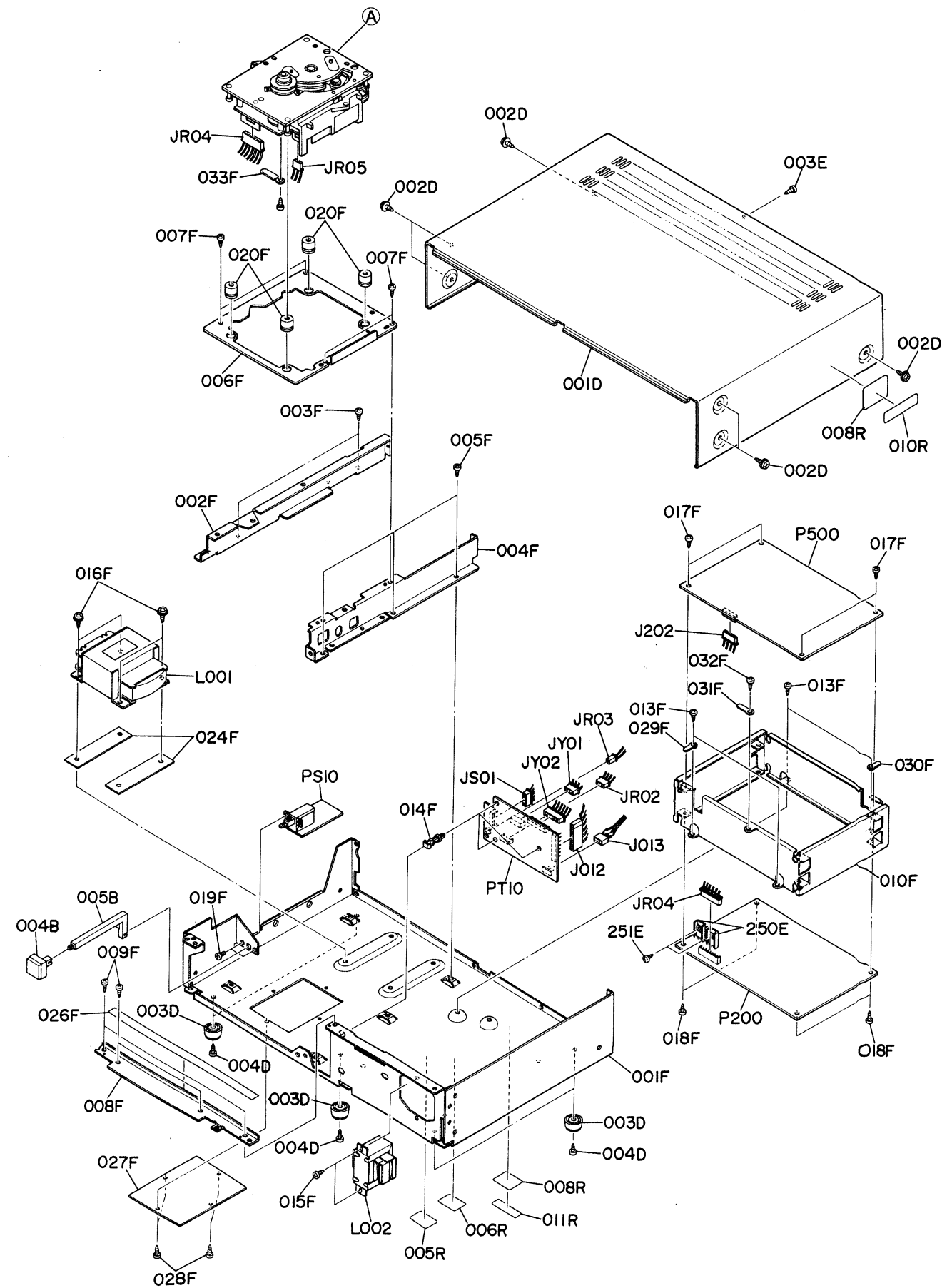

REF. DESIG.	Q'TY					PART NO.	DESCRIPTION
	U	N	A	P	F		
004B	1	1	1	1		106K270010	Button, Power Switch
004B					1	106K270250	Button, Power Switch
005B	1	1	1	1	1	128T121020	Link, Power Switch
001D	1	1	1	1		106K257010	Lid, Top Cover
001D					1	106K257050	Lid, Top Cover
002D	6	6	6	6		51260408Z0	B.T. Screw B4 x 8
002D					6	51260408U0	B.T. Screw B4 x 8
003D	5	5	5	5	5	416H057010	Leg
004D	5	5	5	5	5	51260308U0	B.T. Screw B3 x 8
003E	1	1	1	1	1	51280306Z0	B.H. Tapped Screw B3 x 6
250E	2	2	2	2	2	415H267010	Heatsink, (Q231, Q232)
251E	2	2	2	2	2	51280306B0	B.H. Tapped Screw B3 x 6
001F	1	1	1	1	1	106K105010	Chassis, Main
002F	1	1	1	1	1	106K160010	Bracket, (L)
003F	2	2	2	2	2	51280306B0	B.H. Tapped Screw B3 x 6
004F	1	1	1	1	1	106K160020	Bracket, (R)
005F	4	4	4	4	4	51280306B0	B.H. Tapped Screw B3 x 6
006F	1	1	1	1	1	106K160070	Bracket, Mecha
007F	4	4	4	4	4	51280306B0	B.H. Tapped Screw B3 x 6
008F	1	1	1	1	1	106K160080	Bracket
009F	4	4	4	4	4	51280306B0	B.H. Tapped Screw B3 x 6
010F	1	1	1	1	1	106K109500	Shield Assembly
013F	4	4	4	4	4	51280306B0	B.H. Tapped Screw B3 x 6
014F	3	3	3	3	3	105K101010	Support
015F	2	2	2	2	2	51280306B0	B.H. Tapped Screw B3 x 6
016F	4	4	4	4	4	51260408B0	B.T. Screw B4 x 8
017F	4	4	4	4	4	51280306B0	B.H. Tapped Screw B3 x 6
018F	4	4	4	4	4	51280306B0	B.H. Tapped Screw B3 x 6
019F	2	2	2	2	2	51100306A9	B.H.M. Screw B3 x 6
020F	4					101K259120	Bushing
020F		4	4	4	4	101K259050	Bushing
024F	2	2	2	2	2	106K118010	Spacer
026F	1	1	1	1	1	200T107040	Sheet

REF. DESIG.	Q'TY					PART NO.	DESCRIPTION
	U	N	A	P	F		
027F	1	1	1	1	1	106K257070	Lid, Chassis
028F	4	4	4	4	4	51280306Z0	B.H. Tapped Screw B3 x 6
029F	1	1	1	1	1	62030049W0	Lug
030F	1	1	1	1	1	62030049W0	Lug
031F	1	1	1	1	1	62030049W0	Lug
032F	1	1	1	1	1	51280306Z0	B.H. Tapped Screw B3 x 6
033F	1	1	1	1	1	4220005030	Clamper
005R	1					101K861100	Label, Danger
006R		1	1			105K861070	Label, Class-1
008R		1				117H861010	Label
010R		1	1			2911861140	Label
011R		1	1			2911861110	Label
J012	1	1	1	1	1	YJ06001260	Jack, 7P
J013	1	1	1	1	1	YJ06001040	Jack, 3P
J202	1	1	1	1	1	YB00120110	Connective Cord, 10P
JR02	1	1	1	1	1	YB00320130	Connective Cord, 6P
JR03	1	1	1	1	1	YB00550060	Connective Cord, 2P
JR04	1	1	1	1	1	YB00210080	Connective Cord, 11P
JR05	1	1	1	1	1	YB00420110	Connective Cord, 5P
JS01	1	1	1	1	1	YB00230190	Connective Cord, 8P
JY01	1	1	1	1	1	YB00120150	Connective Cord, 7P
JY02	1	1	1	1	1	YB00230200	Connective Cord, 13P
ΔL001	1					TS17202020	Power Transformer, Main
ΔL001		1	1	1		TS17202030	Power Transformer, Main
ΔL001					1	TS17202010	Power Transformer, Main
ΔL002	1	1	1	1	1	TS14139010	Power Transformer, Sub
A	1	1	1	1	1	107K105400	CDP-3 Assembly, HF-AMP+CHASSIS(K)

[C03-99] REAR PANEL

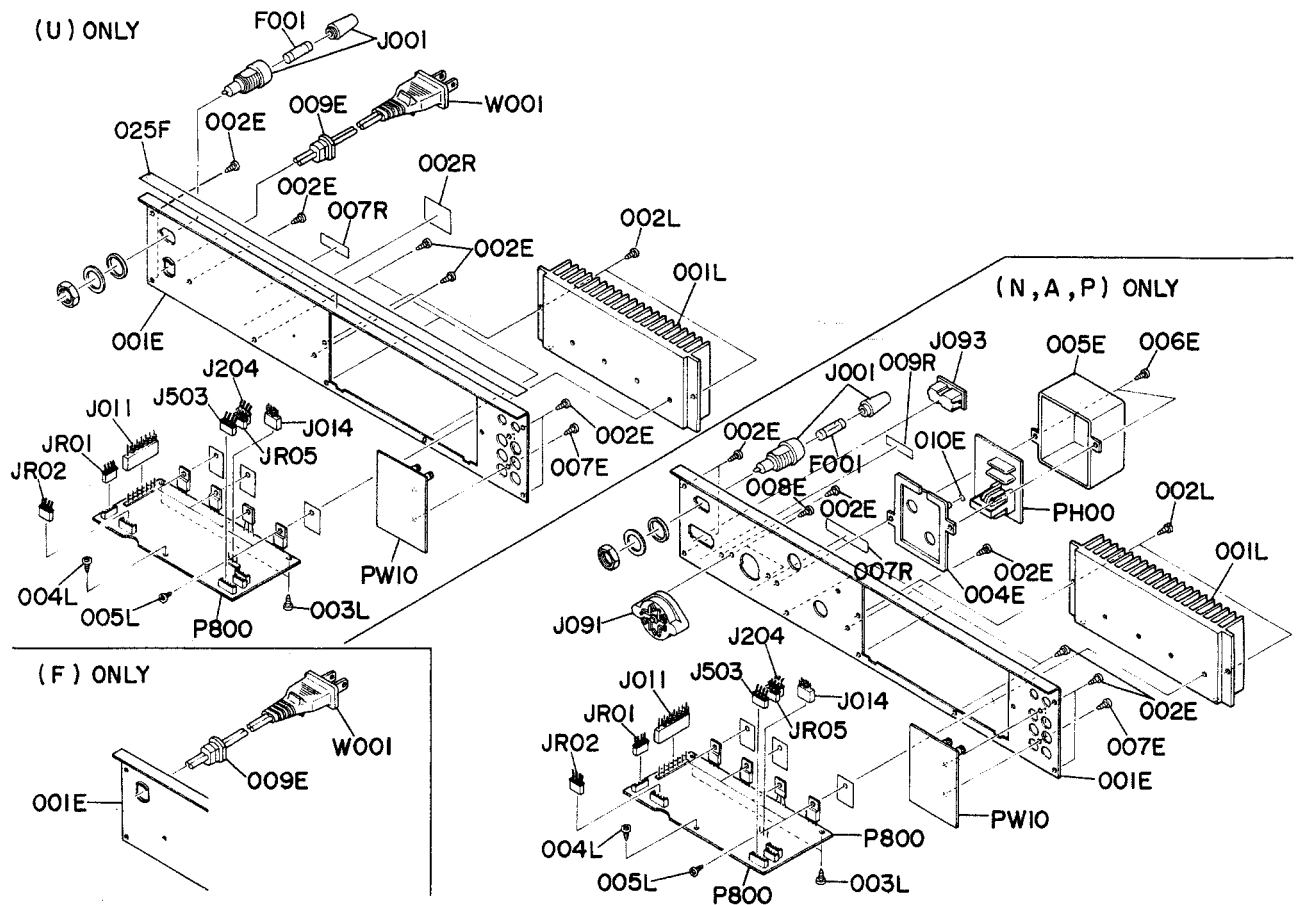

REF. DESIG.	Q'TY					PART NO.	DESCRIPTION
	U	N	A	P	F		
001E	1					106K250030	Rear Panel
001E		1	1	1		106K250020	Rear Panel
001E					1	106K250010	Rear Panel
002E	9	9	9	9	9	51280306U0	B.H. Tapped Screw B3 x 6
004E	1	1	1			101K064020	Case, Filter; Bottom
005E	1	1	1			101K064030	Case, Filter; Top
006E	2	2	2			51280310U0	B.H. Tapped Screw B3 x 10
007E	2	2	2	2	2	51280308U0	B.H. Tapped Screw B3 x 8
008E	2	2	2			51280308U0	B.H. Tapped Screw B3 x 8
009E	1				1	1455259090	Bushing, AC Power Cord
010E	1	1	1			101K056020	Buffer, Filter Case
025F	1	1	1	1	1	106K107010	Sheet
001L	1	1	1	1	1	106K267010	Heatsink, Main
002L	2	2	2	2	2	51280306U0	B.H. Tapped Screw B3 x 6
003L	2	2	2	2	2	51280306U0	B.H. Tapped Screw B3 x 6
004L	1	1	1	1	1	51280306B0	B.H. Tapped Screw B3 x 6
005L	4	4	4	4	4	51280308M0	B.H. Tapped Screw B3 x 8
002R					1	101K861030	Label
007R	1					2112265010	Indicator, Serial No.
007R		1	1	1	1	2112265110	Indicator, Serial No.
009R		1	1	1	1	4581861010	Label, Made in Japan

REF. DESIG.	Q'TY					PART NO.	DESCRIPTION
	U	N	A	P	F		
ΔF001	1					FS10100500	Fuse, 1A 250V
ΔF001		1	1			FS10025800	Fuse, 250mA 250V
ΔF001					1	FS10100700	Fuse, 1A 250V
ΔJ001	1					YJ08000300	Jack, Fuse Holder
ΔJ001		1	1	1		YJ08000290	Jack, Fuse Holder
J011	1	1	1	1	1	YJ06001060	Jack, 7P
J014	1	1	1	1	1	YJ06001040	Jack, 3P
J204	1	1	1	1	1	YB00280250	Connective Cord, 6P
J503	1	1	1	1	1	YB00130190	Connective Cord, 7P
ΔJ091	1	1	1			BY05080050	Voltage Selector
ΔJ093	1	1	1			YP04000580	Plug, AC Inlet
JR01	1	1	1	1	1	YB00480030	Connective Cord, 6P
JR02	1	1	1	1	1	YB00320130	Connective Cord, 6P
JR05	1	1	1	1	1	YB00420110	Connective Cord, 5P
ΔW001	1					YC02000160	A.C. Power Cord
ΔW001					1	YC01800200	A.C. Power Cord

[C05-99] REMOTE CONTROL (RMC-84)

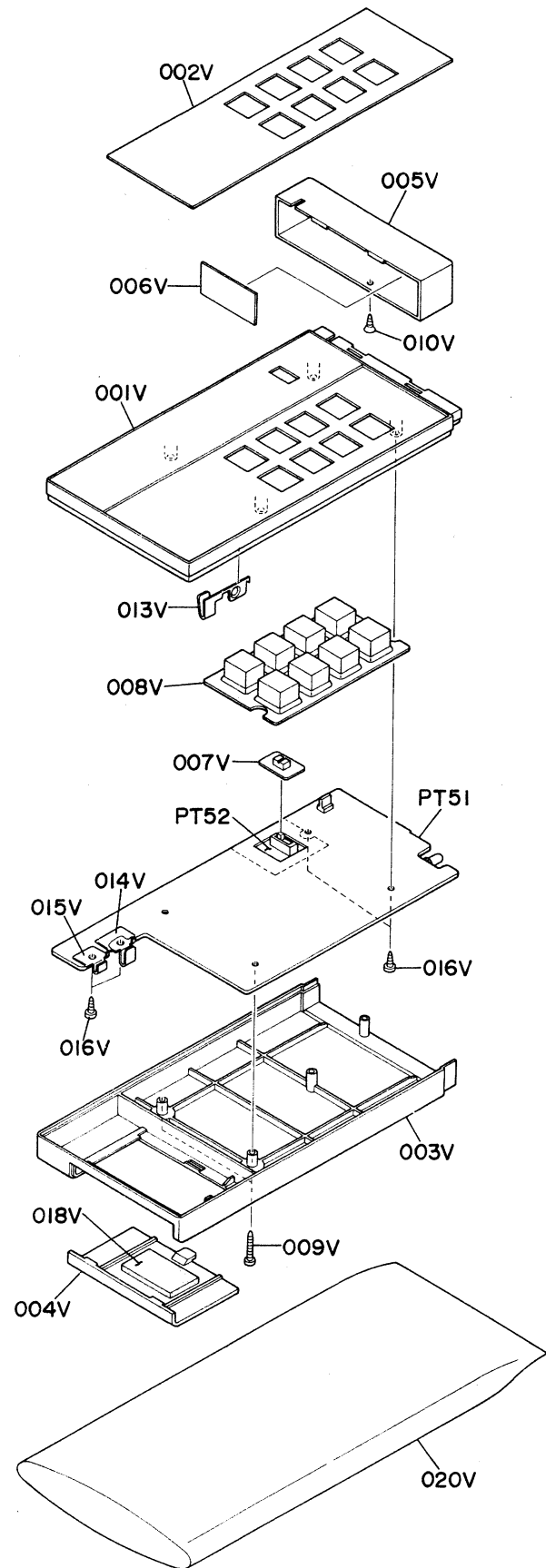

REF. DESIG.	Q'TY					PART NO.	DESCRIPTION
	U	N	A	P	F		
001V	1	1	1			116K064030	Case, Front
001V					1	116K064020	Case, Front
002V	1	1	1			116K063040	Escutcheon, Front Case
002V					1	116K063030	Escutcheon, Front Case
003V	1	1	1			017H064020	Case, Rear
003V					1	017H064320	Case, Rear
004V	1	1	1			017H064030	Case, Battery
004V					1	017H064330	Case, Battery
005V	1	1	1			017H401320	Frame, Top
005V					1	017H401220	Frame, Top
006V	1	1	1			017H158020	Window
007V	1	1	1			116K154020	Knob, ON/OFF
007V					1	116K154010	Knob, ON/OFF
008V	1	1	1			116K127030	Control Board
008V					1	116K127020	Control Board
009V	2	2	2			51402612R0	B.H. Tapped Screw B2.6 x 12
009V					2	51402612T0	B.H. Tapped Screw B2.6 x 12
010V	1	1	1			51420206R0	O.C.H. Tapped Screw O2 x 6
010V					1	51420206T0	O.C.H. Tapped Screw O2 x 6
013V	1	1	1			116K123010	Contactior
014V	1	1	1			017H123010	Contactior
015V	1	1	1			017H123030	Contactior
016V	4	4	4			51302606B0	P.H. Tapped Screw P2.6 x 6
018V	1	1	1			4724056010	Buffer
020V	1	1	1			9011325010	Polyethylene Bag

[P01-99] PACKING MATERIALS

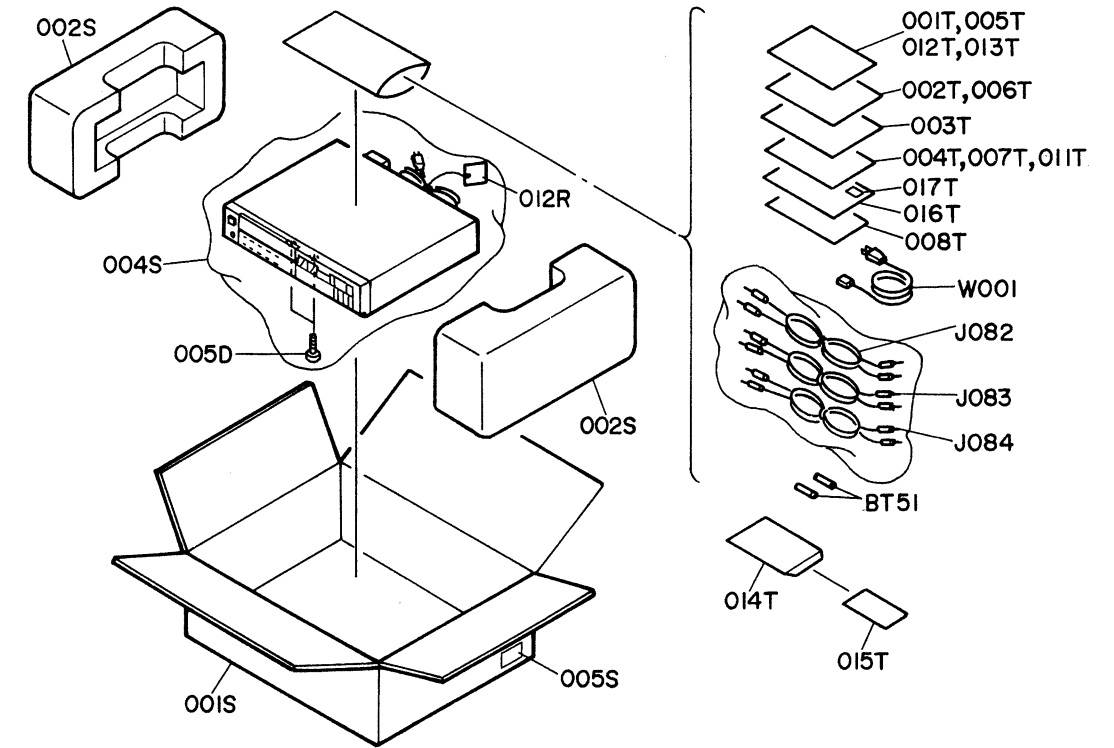

REF. DESIG.	Q'TY					PART NO.	DESCRIPTION
	U	N	A	P	F		
001S	1					106K801020	Packing Case
001S		1	1	1	1	106K801010	Packing Case
002S	2	2	2	2	2	106K809010	Cushion
004S	1	1	1	1	1	9090808030	Polyethylene Sheet
005S	2					9526019010	Serial No. Card
005S		4				9526019060	Serial No. Card
005S			4			9526019030	Serial No. Card
005S				4		9526019050	Serial No. Card
005S					4	9526019040	Serial No. Card
001T	1	1	1			106K851310	User Manual
002T	1	1	1			106K851320	User Manual, Spec
003T	1					106K856010	Circuit Diagram
004T			1			9631000090	Warrantee Card
005T	1					106K851210	User Manual
006T	1					106K851220	User Manual, Spec
007T	1					103H854010	Warrantee Card
008T	1					2225813010	Envelope
011T					1	416H854010	Warrantee Card
012T					1	3435851210	User Manual
013T					1	106K851110	User Manual
014T					1	9631000130	Warrantee Card
015T					1	128T854010	Warrantee Card
016T					1	9611000050	User's Card
017T					1	9540000010	Licence

REF. DESIG.	Q'TY					PART NO.	DESCRIPTION
	U	N	A	P	F		
005D	2	2	2	2	2	51100345Y9	B.H.M.Screw(RED) B3 x 45
012R	1					9560000100	Hang Tag
BT51	2	2	2	2	2	ZB05030010	Battery, AM-3
J082	1	1	1	1	1	ZD01000170	Connective Cord, Audio Out
J083	1	1	1	1	1	ZD01000220	Connective Cord, Easy Out
J084	1	1	1	1	1	ZD01000250	Connective Cord, Remote
ΔW001	1					ZC01805010	A.C. Power Cord
ΔW001			1			ZC02006020	A.C. Power Cord
ΔW001				1		ZC01807010	A.C. Power Cord

17. ELECTRICAL PARTS LIST

(U): for U.S.A.
 (N): for Europe
 (A): for Australia
 (P): for P.X.
 (F): for Japan

REF. DESIG.	Q'TY					PART NO.	DESCRIPTION
	U	N	A	P	F		
P200	1	1	1	1	1	WB106K1820 ZZ106K1820	P200-SERVO CIRCUIT BOARD P.W. Board, Servo P.W. Board Assembly
P200-CAPACITORS							
C201	1	1	1	1	1	DK46103300	Ceramic 0.01μF ±10%,Chip
C203	1	1	1	1	1	DK46103300	Ceramic 0.01μF ±10%,Chip
C204	1	1	1	1	1	DF15104310	Film 0.1μF ±5%
C205	1	1	1	1	1	DF15273310	Film 0.027μF ±5%
C207	1	1	1	1	1	OA47601610	Elect 47μF 16V
C208	1	1	1	1	1	DK46103300	Ceramic 0.01μF ±10%,Chip
C209	1	1	1	1	1	OA10505010	Elect 1μF 50V
C211	1	1	1	1	1	DF15224350	Film 0.22μF ±5%
C212	1	1	1	1	1	DK46331300	Ceramic 330pF ±10%,Chip
C214	1	1	1	1	1	EA22601630	Elect 22μF 16V
C215	1	1	1	1	1	DF15154310	Film 0.15μF ±5%
C216	1	1	1	1	1	DF15153310	Film 0.015μF ±5%
C217	1	1	1	1	1	OA33505010	Elect 3.3μF 50V
C218	1	1	1	1	1	DF15153310	Film 0.015μF ±5%
C219	1	1	1	1	1	DF15473310	Film 0.047μF ±5%
C228	1	1	1	1	1	DF15104310	Film 0.1μF ±5%
C233	1	1	1	1	1	DF15474350	Film 0.47μF ±5%
C235	1	1	1	1	1	DK46103300	Ceramic 0.01μF ±10%,Chip
C236	1	1	1	1	1	DF15562310	Film 5600pF ±5%
C237	1	1	1	1	1	DF15333310	Film 0.033μF ±5%
C238	1	1	1	1	1	DF15562310	Film 5600pF ±5%
C239	1	1	1	1	1	DF74391030	Film 390pF ±2%
C241	1	1	1	1	1	OA47601610	Elect 47μF 16V
C242	1	1	1	1	1	OA47601610	Elect 47μF 16V
C243	1	1	1	1	1	DF15474350	Film 0.47μF ±5%
C244	1	1	1	1	1	DF74681030	Film 680pF ±2%
C246	1	1	1	1	1	DF74682010	Film 6800pF ±2%
C247	1	1	1	1	1	DF74682010	Film 6800pF ±2%
C250	1	1	1	1	1	OA47601610	Elect 47μF 16V
C251	1	1	1	1	1	DF15104310	Film 0.1μF ±5%
C252	1	1	1	1	1	DD45680300	Ceramic 68pF ±5%,Chip
C253	1	1	1	1	1	DD45680300	Ceramic 68pF ±5%,Chip
C256	1	1	1	1	1	DF15182310	Film 1800pF ±5%
C257	1	1	1	1	1	DF15682310	Film 6800pF ±5%
C259	1	1	1	1	1	DF15223310	Film 0.022μF ±5%
C261	1	1	1	1	1	DF74682010	Film 6800pF ±2%
C262	1	1	1	1	1	DF74682010	Film 6800pF ±2%
C265	1	1	1	1	1	OA33701610	Elect 330μF 16V
C266	1	1	1	1	1	OA33701610	Elect 330μF 16V
C267	1	1	1	1	1	EQ10505030	Elect 1μF 50V
C268	1	1	1	1	1	DF16103310	Film 0.01μF ±10%
C280	1	1	1	1	1	DF15104310	Film 0.1μF ±5%
C281	1	1	1	1	1	DK46223200	Ceramic 0.022μF ±10%,Chip
C282	1	1	1	1	1	DK46223200	Ceramic 0.022μF ±10%,Chip
C283	1	1	1	1	1	OA10601610	Elect 10μF 16V
P200-RESISTORS (All Resistors are ±5% & 1/8W)							
R201	1	1	1	1	1	RI05473180	47KΩ, Chip
R202	1	1	1	1	1	RI05105180	1MΩ, Chip
R203	1	1	1	1	1	GD05824140	820KΩ ¼W
R204	1	1	1	1	1	RI05105180	1MΩ, Chip
R205	1	1	1	1	1	RI05104180	100KΩ, Chip
R206	1	1	1	1	1	RI05474180	470KΩ, Chip
R207	1	1	1	1	1	RI05000180	0Ω, Chip

REF. DESIG.	Q'TY					PART NO.	DESCRIPTION
	U	N	A	P	F		
R209	1	1	1	1	1	RI05473180	47KΩ, Chip
R210	1	1	1	1	1	GD05104140	100KΩ ¼W
R211	1	1	1	1	1	RI05472180	4.7KΩ, Chip
R212	1	1	1	1	1	RI05472180	4.7KΩ, Chip
R214	1	1	1	1	1	RI05223180	22KΩ, Chip
R215	1	1	1	1	1	GD05472140	4.7KΩ ¼W
R216	1	1	1	1	1	GD05104100	100KΩ ¼W
R217	1	1	1	1	1	RI05333180	33KΩ, Chip
R219	1	1	1	1	1	RI05222180	2.2KΩ, Chip
R220	1	1	1	1	1	RI05223180	22KΩ, Chip
R221	1	1	1	1	1	RI05682180	6.8KΩ, Chip
R222	1	1	1	1	1	RI05123180	12KΩ, Chip
R223	1	1	1	1	1	RI05104180	100KΩ, Chip
R224	1	1	1	1	1	GD05473140	47KΩ ¼W
R227	1	1	1	1	1	BW05472020	4.7KΩ x 6, Composite
R229	1	1	1	1	1	RI05472180	4.7KΩ, Chip
R230	1	1	1	1	1	RI05563180	56KΩ, Chip
R231	1	1	1	1	1	RI05334180	330KΩ, Chip
R233	1	1	1	1	1	RI05104180	100KΩ, Chip
R234	1	1	1	1	1	RI05472180	4.7KΩ, Chip
R235	1	1	1	1	1	RI05472180	4.7KΩ, Chip
R238	1	1	1	1	1	RI05474180	470KΩ, Chip
R239	1	1	1	1	1	RI05473180	47KΩ, Chip
R240	1	1	1	1	1	GD05033140	3.3Ω ¼W
R242	1	1	1	1	1	RI05565180	5.6MΩ, Chip
R243	1	1	1	1	1	RI05565180	5.6MΩ, Chip
R244	1	1	1	1	1	RI05472180	4.7KΩ, Chip
R245	1	1	1	1	1	RI05154180	150KΩ, Chip
R246	1	1	1	1	1	RI05101180	100Ω, Chip
R247	1	1	1	1	1	GD05102140	1KΩ ¼W
R250	1	1	1	1	1	RI05683180	68KΩ, Chip
R251	1	1	1	1	1	RI05683180	68KΩ, Chip
R252	1	1	1	1	1	RI05681180	680Ω, Chip
R253	1	1	1	1	1	RI05472180	4.7KΩ, Chip
R254	1	1	1	1	1	RI05104180	100KΩ, Chip
R255	1	1	1	1	1	RI05223180	22KΩ, Chip
R256	1	1	1	1	1	GA05033020	3.3Ω 2W
R257	1	1	1	1	1	RI05273180	27KΩ, Chip
R258	1	1	1	1	1	RI05272180	2.7KΩ, Chip
R259	1	1	1	1	1	RI05682180	6.8KΩ, Chip
R260	1	1	1	1	1	RI05563180	56KΩ, Chip
R261	1	1	1	1	1	RI05563180	56KΩ, Chip
R262	1	1	1	1	1	RI05332180	3.3KΩ, Chip
R264	1	1	1	1	1	RI05332180	3.3KΩ, Chip
R276	1	1	1	1	1	RI05472180	4.7KΩ, Chip
R279	1	1	1	1	1	RI01473180	47KΩ, Chip ±1%
R280	1	1	1	1	1	RI01473180	47KΩ, Chip ±1%
R281	1	1	1	1	1	RI05472180	4.7KΩ, Chip
R282	1	1	1	1	1	RI05473180	47KΩ, Chip
R283	1	1	1	1	1	RI05473180	47KΩ, Chip
R284	1	1	1	1	1	GD05103140	10KΩ ¼W
R287	1	1	1	1	1	RI01682180	6.8KΩ, Chip ±1%
R288	1	1	1	1	1	RI01682180	6.8KΩ, Chip ±1%
R291	1	1	1	1	1	GD05473140	47KΩ ¼W
R292	1	1	1	1	1	GD05473140	47KΩ ¼W
R293	1	1	1	1	1	RI05471180	470Ω, Chip
R294	1	1	1	1	1	RI05471180	470Ω, Chip
R298	1	1	1	1	1	RI05471180	470Ω, Chip
R299	1	1	1	1	1	RI05272180	2.7KΩ, Chip

REF. DESIG.	Q'TY					PART NO.	DESCRIPTION
	U	N	A	P	F		
R300	1	1	1	1	1	R105103180	10K Ω , Chip
R301	1	1	1	1	1	R105103180	10K Ω , Chip
R302	1	1	1	1	1	R105222180	2.2K Ω , Chip
R304	1	1	1	1	1	R105103180	10K Ω , Chip
R305	1	1	1	1	1	R105103180	10K Ω , Chip
R306	1	1	1	1	1	R105272180	2.7K Ω , Chip
R307	1	1	1	1	1	R105222180	2.2K Ω , Chip
R308	1	1	1	1	1	R105471180	470 Ω , Chip
R311	1	1	1	1	1	R101823180	82K Ω , Chip $\pm 1\%$
R312	1	1	1	1	1	R101823180	82K Ω , Chip $\pm 1\%$
R313	1	1	1	1	1	R105472180	4.7K Ω , Chip
R315	1	1	1	1	1	RA01030630	10K Ω , Trimming
R316	1	1	1	1	1	R105473180	47K Ω , Chip
R318	1	1	1	1	1	R105821180	820 Ω , Chip
R319	1	1	1	1	1	R105471180	470 Ω , Chip
R320	1	1	1	1	1	GD05152140	1.5K Ω $\frac{1}{4}W$
R323	1	1	1	1	1	R105124180	120K Ω , Chip
R324	1	1	1	1	1	R105753180	75K Ω , Chip
R325	1	1	1	1	1	R105753180	75K Ω , Chip
R326	1	1	1	1	1	R105224180	220K Ω , Chip
R327	1	1	1	1	1	R105104180	100K Ω , Chip
R328	1	1	1	1	1	GD05334140	330K Ω $\frac{1}{4}W$
R335	1	1	1	1	1	R105683180	68K Ω , Chip
R336	1	1	1	1	1	R105472180	4.7K Ω , Chip
R340	1	1	1	1	1	R105103180	10K Ω , Chip
R341	1	1	1	1	1	R105103180	10K Ω , Chip
R342	1	1	1	1	1	R105683180	68K Ω , Chip
R345	1	1	1	1	1	R105473180	47K Ω , Chip
R346	1	1	1	1	1	R105473180	47K Ω , Chip
R349	1	1	1	1	1	R105183180	18K Ω , Chip
R350	1	1	1	1	1	R105184180	180K Ω , Chip
R351	1	1	1	1	1	R105333180	33K Ω , Chip
R352	1	1	1	1	1	R105273180	27K Ω , Chip
R353	1	1	1	1	1	R105472180	4.7K Ω , Chip
R356	1	1	1	1	1	R105363180	36K Ω , Chip
R357	1	1	1	1	1	R105392180	3.9K Ω , Chip
R358	1	1	1	1	1	R105364180	360K Ω , Chip
R359	1	1	1	1	1	R105272180	2.7K Ω , Chip
R360	1	1	1	1	1	R105104140	100K Ω , Chip
R362	1	1	1	1	1	R105104140	100K Ω , Chip
R363	1	1	1	1	1	R105103180	10K Ω , Chip
R364	1	1	1	1	1	R105472180	4.7K Ω , Chip
R365	1	1	1	1	1	R105474180	470K Ω , Chip
R366	1	1	1	1	1	R105334180	330K Ω , Chip
R367	1	1	1	1	1	R105474180	470K Ω , Chip
R370	1	1	1	1	1	R105273180	27K Ω , Chip
R372	1	1	1	1	1	R105473180	47K Ω , Chip
R373	1	1	1	1	1	R105184180	180K Ω , Chip
R375	1	1	1	1	1	R105683180	68K Ω , Chip
R376	1	1	1	1	1	R105472180	4.7K Ω , Chip
R378	1	1	1	1	1	R105273180	27K Ω , Chip
R379	1	1	1	1	1	R105273180	27K Ω , Chip
R380	1	1	1	1	1	R105332180	3.3K Ω , Chip
R381	1	1	1	1	1	R105121180	120 Ω , Chip
R382	1	1	1	1	1	R105121180	120 Ω , Chip
R384	1	1	1	1	1	GA05082020	8.2 Ω 2W
R385	1	1	1	1	1	GA05082020	8.2 Ω 2W
R386	1	1	1	1	1	GD05332140	3.3K Ω $\frac{1}{4}W$
R387	1	1	1	1	1	GD05022140	2.2 Ω $\frac{1}{4}W$

REF. DESIG.	Q'TY					PART NO.	DESCRIPTION
	U	N	A	P	F		
R388	1	1	1	1	1	GD05473140	47K Ω $\frac{1}{4}W$
R391	1	1	1	1	1	R105562180	5.6K Ω , Chip
R392	1	1	1	1	1	R105133180	13K Ω , Chip
R393	1	1	1	1	1	R105223180	22K Ω , Chip
R394	1	1	1	1	1	R105334180	330K Ω , Chip
R395	1	1	1	1	1	R105223180	22K Ω , Chip
R396	1	1	1	1	1	R105563180	56K Ω , Chip
R397	1	1	1	1	1	R105563180	56K Ω , Chip
R398	1	1	1	1	1	R105182180	1.8K Ω , Chip
R399	1	1	1	1	1	R105182180	1.8K Ω , Chip
R401	1	1	1	1	1	R105332180	3.3K Ω , Chip
R402	1	1	1	1	1	R105472180	4.7K Ω , Chip
R403	1	1	1	1	1	GA05820010	82 Ω 1W
D244	1	1	1	1	1	HD20001000	P200-SEMICONDUCTORS Diode 1S1555
D245	1	1	1	1	1	HZ20001020	Diode MA151WK,Chip
D246	1	1	1	1	1	HD20001000	Diode 1S1555
D249	1	1	1	1	1	HD20001000	Diode 1S1555
D250	1	1	1	1	1	HD20001000	Diode 1S1555
D251	1	1	1	1	1	HD30041010	Zener HZ2C2
D252	1	1	1	1	1	HD30021060	Zener RD5.1EB2
D253	1	1	1	1	1	HZ30001020	Zener MA3068-M, Chip
D255	1	1	1	1	1	HD20001000	Diode 1S1555
D256	1	1	1	1	1	HD20001000	Diode 1S1555
D257	1	1	1	1	1	HD20001000	Diode 1S1555
D258	1	1	1	1	1	HD20001000	Diode 1S1555
D259	1	1	1	1	1	HD20001000	Diode 1S1555
Q201	1	1	1	1	1	HC10105060	IC U-CON Servo
Q205	1	1	1	1	1	HC10081060	IC μ PC339C
Q207	1	1	1	1	1	HC10055010	IC HD14025B
Q208	1	1	1	1	1	HC10003090	IC NJM4558D
Q209	1	1	1	1	1	HC10003090	IC NJM4558D
Q211	1	1	1	1	1	HC10056010	IC HD14053B
Q212	1	1	1	1	1	HC10082060	IC μ PC324C
Q213	1	1	1	1	1	HC10057010	IC HD14070B
Q214	1	1	1	1	1	HC10082060	IC μ PC324C
Q215	1	1	1	1	1	HC10082060	IC μ PC324C
Q217	1	1	1	1	1	HC10003090	IC NJM4558D
Q218	1	1	1	1	1	HC10083060	IC μ PC741C
Q219	1	1	1	1	1	HC10058010	IC HD74LS74A
Q220	1	1	1	1	1	HC10058010	IC HD74LS74A
Q230	1	1	1	1	1	HT309452B0	Transistor 2SC945(P, Q)
Q231	1	1	1	1	1	HT328241Y0	Transistor 2SC2824(Y)
Q232	1	1	1	1	1	HT111841Y0	Transistor 2SA1184(Y)
Q233	1	1	1	1	1	HT313841R0	Transistor 2SC1384(R)
Q234	1	1	1	1	1	HT106841R0	Transistor 2SA684(R)
Q238	1	1	1	1	1	HT309452B0	Transistor 2SC945(P, Q)
Q239	1	1	1	1	1	HT309452B0	Transistor 2SC945(P, Q)
Q240	1	1	1	1	1	HT111841Y0	Transistor 2SA1184(Y)
Q241	1	1	1	1	1	HT328241Y0	Transistor 2SC2824(Y)
Q242	1	1	1	1	1	HT107332A0	Transistor 2SA733(P, Q)
Q243	1	1	1	1	1	HT333811G0	Transistor 2SC3381(GR)
Q244	1	1	1	1	1	HT333811G0	Transistor 2SC3381(GR)
Q245	1	1	1	1	1	HT309452B0	Transistor 2SC945(P, Q)
Q246	1	1	1	1	1	HT309452B0	Transistor 2SC945(P, Q)
Q401	1	1	1	1	1	HT327852A0	Transistor 2SC2785(RF, JF)
Q402	1	1	1	1	1	HT313841R0	Transistor 2SC1384(R)

REF. DESIG.	Q'TY					PART NO.	DESCRIPTION
	U	N	A	P	F		
J201	1	1	1	1	1	YJ06003110	P200-MISCELLANEOUS Jack, 11P
X201	1	1	1	1	1	FQ03504010	Seramic Vibrator, 3.58MHz
P500	1	1	1	1	1	WB106K1810	P500-DECODER/ HEADPHONE AMP CIRCUIT BOARD P.W. Board, Decoder Head- phone Amp
	1	1	1	1		ZZ106K1810	P.W. Board Assembly
							P500-CAPACITORS
C501	1	1	1	1	1	DF16104310	Film 0.1µF ±10%
C502	1	1	1	1	1	DF16104310	Film 0.1µF ±10%
C503	1	1	1	1	1	DF74223030	Film 0.022µF ±2%
C504	1	1	1	1	1	DK46223300	Ceramic 0.022µF ±10%, Chip
C505	1	1	1	1	1	DK46222300	Ceramic 2200pF ±10%, Chip
C507	1	1	1	1	1	DK46272300	Ceramic 2700pF ±10%, Chip
C508	1	1	1	1	1	DK46821300	Ceramic 820pF ±10%, Chip
C509	1	1	1	1	1	DK46472300	Ceramic 4700pF ±10%, Chip
C510	1	1	1	1	1	DK46222300	Ceramic 2200pF ±10%, Chip
C511	1	1	1	1	1	DK46103300	Ceramic 0.01µF ±10%, Chip
C512	1	1	1	1	1	OA47601610	Elect 47µF 16V
C513	1	1	1	1	1	DF74223030	Film 0.022µF ±2%
C521	1	1	1	1	1	DK46103300	Ceramic 0.01µF ±10%, Chip
C522	1	1	1	1	1	DK46103300	Ceramic 0.01µF ±10%, Chip
C523	1	1	1	1	1	DK46471300	Ceramic 470pF ±10%, Chip
C524	1	1	1	1	1	DK46471300	Ceramic 470pF ±10%, Chip
C525	1	1	1	1	1	DK46222300	Ceramic 2200pF ±10%, Chip
C526	1	1	1	1	1	DF15104310	Film 0.1µF ±5%
C528	1	1	1	1	1	DK46103300	Ceramic 0.01µF ±10%, Chip
C529	1	1	1	1	1	OA47601610	Elect 47µF 16V
C549	1	1	1	1	1	DK46223300	Ceramic 0.022µF ±10%, Chip
C550	1	1	1	1	1	DK46223300	Ceramic 0.022µF ±10%, Chip
C551	1	1	1	1	1	DD45680300	Ceramic 68pF ±5%, Chip
C552	1	1	1	1	1	DD45330300	Ceramic 33pF ±5%, Chip
C553	1	1	1	1	1	DK46103300	Ceramic 0.01µF ±10%, Chip
C554	1	1	1	1	1	OA47601610	Elect 47µF 16V
C555	1	1	1	1	1	DK46103300	Ceramic 0.01µF ±10%, Chip
C556	1	1	1	1	1	DK46103300	Ceramic 0.01µF ±10%, Chip
C557	1	1	1	1	1	DK46223300	Ceramic 0.022µF ±10%, Chip
C561	1	1	1	1	1	EA47602560	Elect 47µF 25V
C562	1	1	1	1	1	DF16223310	Film 0.022µF ±10%
C563	1	1	1	1	1	DF16223310	Film 0.022µF ±10%
C564	1	1	1	1	1	DK16821300	Ceramic 820pF ±10%
C565	1	1	1	1	1	DF16223310	Film 0.022µF ±10%
C566	1	1	1	1	1	DF15474350	Film 0.47µF ±5%
C567	1	1	1	1	1	DF15474350	Film 0.47µF ±5%
C568	1	1	1	1	1	DF16104310	Film 0.1µF ±10%
C569	1	1	1	1	1	DF16152310	Film 1500pF ±10%
C570	1	1	1	1	1	DF16104310	Film 0.1µF ±10%
C571	1	1	1	1	1	DF16104310	Film 0.1µF ±10%
C572	1	1	1	1	1	DF16223310	Film 0.022µF ±10%
C573	1	1	1	1	1	DF16223310	Film 0.022µF ±10%
C574	1	1	1	1	1	DF16223310	Film 0.022µF ±10%
C575	1	1	1	1	1	DF16223310	Film 0.022µF ±10%
C576	1	1	1	1	1	DF16223310	Film 0.022µF ±10%
C581	1	1	1	1	1	EA47602560	Elect 47µF 25V
C582	1	1	1	1	1	DF16223310	Film 0.022µF ±10%

REF. DESIG.	Q'TY					PART NO.	DESCRIPTION
	U	N	A	P	F		
C583	1	1	1	1	1	DF16223310	Film 0.022µF ±10%
C584	1	1	1	1	1	DK16821300	Ceramic 820pF ±10%
C585	1	1	1	1	1	DF16223310	Film 0.022µF ±10%
C586	1	1	1	1	1	DF15474350	Film 0.47µF ±5%
C587	1	1	1	1	1	DF15474350	Film 0.47µF ±5%
C588	1	1	1	1	1	DF16104310	Film 0.1µF ±10%
C589	1	1	1	1	1	DF16152310	Film 1500pF ±10%
C590	1	1	1	1	1	DF16104310	Film 0.1µF ±10%
C591	1	1	1	1	1	DF16104310	Film 0.1µF ±10%
C592	1	1	1	1	1	DF16223310	Film 0.022µF ±10%
C593	1	1	1	1	1	DF16223310	Film 0.022µF ±10%
C594	1	1	1	1	1	DF16223310	Film 0.022µF ±10%
C595	1	1	1	1	1	DF16223310	Film 0.022µF ±10%
C596	1	1	1	1	1	DF16223310	Film 0.022µF ±10%
C601	1	1	1	1	1	DF55512530	Film 5100pF ±5%
C602	1	1	1	1	1	DF74153010	Film 0.015µF ±2%
C603	1	1	1	1	1	DF55222530	Film 2200pF ±5%
C604	1	1	1	1	1	EA47602560	Elect 47µF 25V
C605	1	1	1	1	1	DF55222530	Film 2200pF ±5%
C606	1	1	1	1	1	DF55122530	Film 1200pF ±5%
C607	1	1	1	1	1	EA10701660	Elect 100µF 16V
C608	1	1	1	1	1	EA10701660	Elect 100µF 16V
C610	1	1	1	1	1	OA10701610	Elect 100µF 16V
C611	1	1	1	1	1	OA10701610	Elect 100µF 16V
C612	1	1	1	1	1	DF55222510	Film 2200pF ±5%
C621	1	1	1	1	1	DF55512530	Film 5100pF ±5%
C622	1	1	1	1	1	DF74153010	Film 0.015µF ±2%
C623	1	1	1	1	1	DF55222530	Film 2200pF ±5%
C624	1	1	1	1	1	EA47602560	Elect 47µF 25V
C625	1	1	1	1	1	DF55222530	Film 2200pF ±5%
C626	1	1	1	1	1	DF55122530	Film 1200pF ±5%
C627	1	1	1	1	1	EA10701660	Elect 100µF 16V
C628	1	1	1	1	1	EA10701660	Elect 100µF 16V
C641	1	1	1	1	1	OA22700610	Elect 220µF 6.3V
C652	1	1	1	1	1	DF55222510	Film 2200pF ±5%
							P500-RESISTORS (All Resistors are ±5% & 1/8W)
R501	1	1	1	1	1	R105102180	1KΩ, Chip
R502	1	1	1	1	1	R105105180	1MΩ, Chip
R503	1	1	1	1	1	R105105180	1MΩ, Chip
R504	1	1	1	1	1	GD05183140	18KΩ ¼W
R505	1	1	1	1	1	R105474180	470KΩ, Chip
R506	1	1	1	1	1	R105474180	470KΩ, Chip
R507	1	1	1	1	1	R105184180	180KΩ, Chip
R508	1	1	1	1	1	R105183180	18KΩ, Chip
R509	1	1	1	1	1	GD05392140	3.9KΩ ¼W
R510	1	1	1	1	1	R105103180	10KΩ, Chip
R511	1	1	1	1	1	R105104180	100KΩ, Chip
R512	1	1	1	1	1	GD05184140	180KΩ ¼W
R514	1	1	1	1	1	R105000180	0Ω, Chip
R521	1	1	1	1	1	GD05222140	2.2KΩ ¼W
R522	1	1	1	1	1	R105223180	22KΩ, Chip
R523	1	1	1	1	1	R105103180	10KΩ, Chip
R524	1	1	1	1	1	R105222180	2.2KΩ, Chip
R525	1	1	1	1	1	R105222180	2.2KΩ, Chip
R526	1	1	1	1	1	R105391180	390Ω, Chip
R527	1	1	1	1	1	R105223180	22KΩ, Chip

REF. DESIG.	Q'TY					PART NO.	DESCRIPTION
	U	N	A	P	F		
R528	1	1	1	1	1	RI05103180	10KΩ, Chip
R529	1	1	1	1	1	RI05332180	3.3KΩ, Chip
R530	1	1	1	1	1	RI05104180	100KΩ, Chip
R531	1	1	1	1	1	RI05103180	10KΩ, Chip
R532	1	1	1	1	1	RI05104180	100KΩ, Chip
R533	1	1	1	1	1	RI05473180	47KΩ, Chip
R534	1	1	1	1	1	RI05274180	270KΩ, Chip
R535	1	1	1	1	1	RI05393180	39KΩ, Chip
R536	1	1	1	1	1	GD05104140	100KΩ ¼W
R537	1	1	1	1	1	GD05472140	4.7KΩ ¼W
R538	1	1	1	1	1	RI05472180	4.7KΩ, Chip
R549	1	1	1	1	1	GD05010140	1Ω ¼W
R550	1	1	1	1	1	RI05102180	1KΩ, Chip
R558	1	1	1	1	1	RI05105180	1MΩ, Chip
R559	1	1	1	1	1	RI05102180	1KΩ, Chip
R560	1	1	1	1	1	GD05471140	470Ω ¼W
R561	1	1	1	1	1	RI05151180	150Ω, Chip
R562	1	1	1	1	1	RI05102180	1KΩ, Chip
R563	1	1	1	1	1	RI05102180	1KΩ, Chip
R564	1	1	1	1	1	RI05102180	1KΩ, Chip
R565	1	1	1	1	1	RI05102180	1KΩ, Chip
△R571	1	1	1	1	1	GG05101140	100Ω ¼W
R572	1	1	1	1	1	RI05101180	100Ω, Chip
R573	1	1	1	1	1	RI05272180	2.7KΩ, Chip
R574	1	1	1	1	1	RI05621180	620Ω, Chip
R575	1	1	1	1	1	RI05820180	82Ω, Chip
△R581	1	1	1	1	1	GG05101140	100Ω ¼W
R582	1	1	1	1	1	RI05101180	100Ω, Chip
R583	1	1	1	1	1	RI05272180	2.7KΩ, Chip
R584	1	1	1	1	1	RI05621180	620Ω, Chip
R585	1	1	1	1	1	RI05820180	82Ω, Chip
R591	1	1	1	1	1	GD05102140	1KΩ ¼W
R592	1	1	1	1	1	GM21417810	1.78KΩ ±2% ¼W
R593	1	1	1	1	1	GD05105140	1MΩ ¼W
R594	1	1	1	1	1	GM21456220	56.2KΩ ±2% ¼W
R595	1	1	1	1	1	RI05222180	2.2KΩ, Chip
R596	1	1	1	1	1	RI05222180	2.2KΩ, Chip
R597	1	1	1	1	1	RI05103180	10KΩ, Chip
R598	1	1	1	1	1	GM214464G0	46.4Ω ±2% ¼W
R611	1	1	1	1	1	GD05102140	1KΩ ¼W
R612	1	1	1	1	1	GM21417810	1.78KΩ ±2% ¼W
R613	1	1	1	1	1	GD05105140	1MΩ ¼W
R614	1	1	1	1	1	GM21456220	56.2KΩ ±2% ¼W
R615	1	1	1	1	1	RI01222180	2.2KΩ, Chip ±1%
R616	1	1	1	1	1	RI01222180	2.2KΩ, Chip ±1%
R617	1	1	1	1	1	RI05103180	10KΩ, Chip
R618	1	1	1	1	1	GM214464G0	46.4Ω ±2% ¼W
R623	1	1	1	1	1	RI05000180	0Ω, Chip
R651	1	1	1	1	1	GD05472140	4.7KΩ ¼W
R652	1	1	1	1	1	RI05153180	15KΩ, Chip
R653	1	1	1	1	1	GD05332140	3.3KΩ ¼W
R654	1	1	1	1	1	RI05562180	5.6KΩ, Chip
R655	1	1	1	1	1	RI05822180	8.2KΩ, Chip
R661	1	1	1	1	1	GD05221140	220Ω ¼W
R664	1	1	1	1	1	RI05222180	2.2KΩ, Chip
R665	1	1	1	1	1	RI05472180	4.7KΩ, Chip
R666	1	1	1	1	1	RI05221180	220Ω, Chip
R681	1	1	1	1	1	GD05221140	220Ω ¼W
R684	1	1	1	1	1	RI05222180	2.2KΩ, Chip
R685	1	1	1	1	1	RI05472180	4.7KΩ, Chip
R686	1	1	1	1	1	RI05221180	220Ω, Chip

REF. DESIG.	Q'TY					PART NO.	DESCRIPTION
	U	N	A	P	F		
D545	1	1	1	1	1	HZ20002020	P500-SEMICONDUCTORS
D546	1	1	1	1	1	HD20001210	Diode MA151WA, Chip
△D547	1	1	1	1	1	HD20001000	Diode 1S2473
D549	1	1	1	1	1	HZ20001020	Diode 1S1555
D551	1	1	1	1	1	HZ20001020	Diode MA151WA,Chip
D557	1	1	1	1	1	HD20001210	Diode MA151WA,Chip
D558	1	1	1	1	1	HD20001210	Diode 1S2473
D559	1	1	1	1	1	HZ20005020	Diode 1S2473
D561	1	1	1	1	1	HD40006030	Diode MA153, Chip
D562	1	1	1	1	1	HD40006030	Varicap SVC321SP
Q501	1	1	1	1	1	HC10022270	Varicap SVC321SP
Q502	1	1	1	1	1	HT327852A0	IC SAA7011
Q503	1	1	1	1	1	HT327852A0	Transistor 2SC2785(RF,JF)
Q504	1	1	1	1	1	HT327852A0	Transistor 2SC2785(RF,JF)
Q508	1	1	1	1	1	HC10084060	Transistor 2SC2785(RF,JF)
Q510	1	1	1	1	1	HC10023270	IC μPC393C
Q512	1	1	1	1	1	HC10098060	IC SAA7020
Q514	1	1	1	1	1	HC10021270	IC μPD4016C
Q517	1	1	1	1	1	HC10024270	IC SAA7000
Q519	1	1	1	1	1	HC10025270	IC SAA7030
Q520	1	1	1	1	1	HC10025270	IC TDA1540D
Q523	1	1	1	1	1	HC10021090	IC TDA1540D
Q525	1	1	1	1	1	HC10021090	IC 4560DD
Q527	1	1	1	1	1	HC10021090	IC 4560DD
Q535	1	1	1	1	1	HT111752A0	IC 4560DD
Q536	1	1	1	1	1	HT111752A0	Transistor 2SA1175(RF,JF)
J502	1	1	1	1	1	YJ06003100	Transistor 2SA1175(RF,JF)
J505	1	1	1	1	1	YP06001040	Jack, 10P
L501	1	1	1	1	1	LO74013050	Plug, 3P
L502	1	1	1	1	1	LC14730040	OSC Coil, 7.5μH
L507	1	1	1	1	1	LY10050040	Choke Coil, 47μH
L508	1	1	1	1	1	LY10050040	Relay, Reed
L510	1	1	1	1	1	LY20045010	Relay, Reed
X504	1	1	1	1	1	XB108002L2	Relay, SZ-2101
P800	1	1	1	1	1	WB106K1830	Crystal, 4.2336MHz
	1	1	1	1	1	ZZ106K1830	P500-MISCELLANEOUS
CM03	1	1	1	1	1	DF16104310	Jack, 10P
CM04	1	1	1	1	1	DK46103300	Plug, 3P
C803	1	1	1	1	1	OA47801610	OSC Coil, 7.5μH
C804	1	1	1	1	1	OA22701610	Choke Coil, 47μH
C806	1	1	1	1	1	OA10801610	Relay, Reed
C808	1	1	1	1	1	OA22701610	Relay, Reed
C812	1	1	1	1	1	OA33802510	Relay, SZ-2101
C812	1	1	1	1	1	EB68802530	Crystal, 4.2336MHz
C813	1	1	1	1	1	OA33802510	P800-POWER SUPPLY
C813	1	1	1	1	1	EB68802530	CIRCUIT BOARD
C814	1	1	1	1	1	OA22701610	P.W. Board, Power Supply
C815	1	1	1	1	1	OA10601610	P.W. Board Assembly
C819	1	1	1	1	1	OA22701610	P800-CAPACITORS
△C822	1	1	1	1	1	OA10701010	Film 0.1μF ±10%
C824	1	1	1	1	1	OA33705010	Ceramic 0.01μF ±10%,Chip

REF. DESIG.	Q'TY					PART NO.	DESCRIPTION
	U	N	A	P	F		
							P800-RESISTORS (All Resistors are $\pm 5\%$ & 1/8W)
R801					1	GD05101140	100 Ω
R805	1	1	1	1	1	GD05681140	680 Ω
R809	1	1	1	1	1	GD05561140	560 Ω
R810	1	1	1	1	1	GD05102140	1K Ω
RM01	1	1	1	1	1	GD05183140	18K Ω
RM02	1	1	1	1	1	GD05223140	22K Ω
Δ RM05	1	1	1	1	1	NF05047140	4.7 Ω , Fuse
Δ RM05					1	GD05047140	4.7 Ω
RM07	1	1	1	1	1	RI05473180	47K Ω 1/8W,Chip
							P800-SEMICONDUCTORS
Δ D801	1	1	1	1	1	HD20026080	Diode RB151
D802	1	1	1	1	1	HD20022030	Diode DSF10C-BT
Δ D803	1	1	1	1	1	HD20021290	Diode S1VB20
Δ D804	1	1	1	1	1	HD20022030	Diode DSF10C-BT
Δ D805	1	1	1	1	1	HD20022030	Diode DSF10C-BT
Δ D806	1	1	1	1	1	HD20022030	Diode DSF10C-BT
D807	1	1	1	1	1	HD30040060	Zener RD5.6E
D808	1	1	1	1	1	HD30041060	Zener RD6.8E
D809	1	1	1	1	1	HD30040060	Zener RD5.6E
DM01	1	1	1	1	1	HD30043060	Zener RD8.2E
Δ Q801	1	1	1	1	1	FU20215010	Protector Unit, ICP-F50
Q803	1	1	1	1	1	HC10056060	IC μ PC7805H
Q805	1	1	1	1	1	HT315682A0	Transistor 2SC1568
Δ Q806	1	1	1	1	1	FU20215010	Protector Unit, ICP-F50
Δ Q807	1	1	1	1	1	FU20215010	Protector Unit, ICP-F50
Q808	1	1	1	1	1	FU60115010	Protector Unit, ICP-F15
Q809	1	1	1	1	1	FU60115010	Protector Unit, ICP-F15
Q810	1	1	1	1	1	HC10043060	IC μ PC7812H
Q811	1	1	1	1	1	HC10044060	IC μ PC7912H
Q812	1	1	1	1	1	HT206321F0	Transistor 2SB632K(F)
Δ Q813	1	1	1	1	1	FU40115010	Protector Unit, ICP-F10
Q815	1	1	1	1	1	HT107332A0	Transistor 2SA733(P, Q)
QM02	1	1	1	1	1	HC10148030	IC LB1645N
							P800-MISCELLANEOUS
J801	1	1	1	1	1	YP06001060	Plug, 7P
J802	1	1	1	1	1	YJ06003060	Jack, 6P
J803	1	1	1	1	1	YJ06003070	Jack, 7P
J804	1	1	1	1	1	YJ06003050	Jack, 5P
J805	1	1	1	1	1	YP06001040	Plug, 3P
JM06	1	1	1	1	1	YJ06003060	Jack, 6P
JM07	1	1	1	1	1	YJ06003060	Jack, 6P
SM01	1	1	1	1	1	SP01010800	Push Switch, Tray Open/Close
							PH00-FILTER CIRCUIT BOARD
PH00	1	1	1	1	1	WB106K1860	P.W. Board, Filter
	1	1	1	1	1	ZZ106K8860	P.W. Board Assembly
							PH00-CAPACITORS
Δ CH01	1	1	1	1	1	DF77154810	Film 0.15 μ F $\pm 20\%$ 250V
Δ CH02	1	1	1	1	1	DF77154810	Film 0.15 μ F $\pm 20\%$ 250V
Δ CH03	1	1	1	1	1	DK16471800	Ceramic 470pF $\pm 10\%$ 400V
Δ CH04	1	1	1	1	1	DK16471800	Ceramic 470pF $\pm 10\%$ 400V
							PH00-RESISTOR
Δ RH01	1	1	1	1	1	RC05224120	220K Ω $\pm 5\%$ $\frac{1}{2}$ W
							PH00-MISCELLANEOUS
Δ LH01	1	1	1	1	1	TZ11560010	Choke Trans, 15mH x 2

REF. DESIG.	Q'TY					PART NO.	DESCRIPTION
	U	N	A	P	F		
							PS10-POWER SWITCH CIRCUIT BOARD
PS10	1	1	1	1	1	WB106K1870	P.W. Board, Power Switch
	1	1	1	1	1	ZZ106K1870	P.W. Board Assembly
Δ G801	1	1	1	1	1	DK18103840	Ceramic Cap. 0.01 μ F
Δ G801					1	DF16104510	Film Cap. 0.1 μ F $\pm 10\%$
Δ S801	1	1	1	1	1	SP01010650	Push Switch, Power
							PS20-TEN KEY CIRCUIT BOARD
PS20	1	1	1	1	1	WB106K2420	P.W. Board, Ten Key
	1	1	1	1	1	ZZ106K2420	P.W. Board Assembly
SS01	?	16	16	16	16	SP01010800	Push Switch, Tack
SS16							
							PT10-FEATER U-CON CIRCUIT BOARD
PT10	1	1	1	1	1	WB106K1840	P.W. Board, Feater U-Con
	1	1	1	1	1	ZZ106K1840	P.W. Board Assembly
							PT10-CAPACITORS
CT01	1	1	1	1	1	DK46223300	Ceramic 0.022 μ F $\pm 10\%$
CT02	1	1	1	1	1	OA10505010	Elect 1 μ F 50V
CT04	1	1	1	1	1	DK46103300	Ceramic 0.01 μ F $\pm 10\%$
CT05	1	1	1	1	1	OA10505010	Elect 1 μ F 50V
CT11	1	1	1	1	1	OA10605010	Elect 10 μ F 50V
CT12	1	1	1	1	1	OA10602510	Elect 10 μ F 25V
CT13	1	1	1	1	1	OA22703510	Elect 220 μ F 35V
							PT10-RESISTORS (All Resistors are $\pm 5\%$ & 1/4W)
RT01	1	1	1	1	1	WB05472020	4.7K Ω x 6, Composite
RT02	1	1	1	1	1	GD05473140	47K Ω
RT03	1	1	1	1	1	RI05333180	33K Ω 1/8W,Chip
RT04	1	1	1	1	1	GD05223140	22K Ω
RT05	1	1	1	1	1	GD05102140	1K Ω
RT06	1	1	1	1	1	BW05472010	4.7K Ω x 4, Composite
RT07	1	1	1	1	1	GD05154140	150K Ω
RT08	1	1	1	1	1	RI05472180	4.7K Ω 1/8W, Chip
RT09	1	1	1	1	1	RI05472180	4.7K Ω 1/8W, Chip
RT11	1	1	1	1	1	GD05152140	1.5K Ω
RT12	1	1	1	1	1	GD05471140	470 Ω
							RT10-SEMICONDUCTORS
DT01	1	1	1	1	1	HD20001000	Diode 1S1555
DT02	1	1	1	1	1	HD20022030	Diode DSF10C
DT03	1	1	1	1	1	HD20022030	Diode DSF10C
DT04	1	1	1	1	1	HD30043060	Zener RD8.2E
DT05	1	1	1	1	1	HD30022060	Zener RD22E
DT07	1	1	1	1	1	HD20001000	Diode 1S1555
QT01	1	1	1	1	1	HC10104060	IC μ PD1512ACU
QT02	1	1	1	1	1	HT313842A0	Transistor 2SC1384

REF. DESIG.	Q'TY					PART NO.	DESCRIPTION
	U	N	A	P	F		
PT10-MISCELLANEOUS							
JT01	1	1	1	1	1	YJ06003070	Jack, 7P
JT02	1	1	1	1	1	YJ06003160	Jack, 13P
JT03	1	1	1	1	1	YJ06003080	Jack, 8P
JT04	1	1	1	1	1	YJ06003080	Jack, 8P
JT06	1	1	1	1	1	YJ06002390	Jack, 5P
JT07	1	1	1	1	1	YJ06001980	Jack, 2P
JT09	1	1	1	1	1	YJ06001060	Jack, 7P
JT10	1	1	1	1	1	YJ06001040	Jack, 3P
LT01	1	1	1	1	1	LC14730040	Choke Coil, 47 μ H
PU10-HEADPHONE CIRCUIT BOARD							
PU10	1	1	1	1	1	WB106K1880	P.W. Board, Headphone
	1	1	1	1	1	ZZ106K1880	P.W. Board Assembly
PJ21	1	1	1	1	1	YJ01001790	Jack, Headphone
PJ21					1	YJ01002080	Jack, Headphone
PW10-RCA OUTPUT VR. CIRCUIT BOARD							
PW10	1	1	1	1	1	WB106K1850	P.W. Board, RCA Output VR.
	1					ZZ106K1850	P.W. Board Assembly
		1	1	1		ZZ106K8850	P.W. Board Assembly
PW10-RESISTORS							
RW01	1	1	1	1	1	RB02220010	2K Ω , Variable
RW02	1	1	1	1	1	RB02220010	2K Ω , Variable
RW03	1	1	1	1	1	RI05221180	220 Ω \pm 5% 1/8W,Chip
RW05	1	1	1	1	1	RI05473180	47K Ω \pm 5% 1/8W,Chip
RW07	1	1	1	1	1	RI05472180	4.7K Ω \pm 5% 1/8W,Chip
PW10-SEMICONDUCTORS							
DW01	1	1	1	1	1	HD30035060	Zener RD6.3E
QW01	1	1	1	1	1	BA20001020	Semicon Composite, UN2215
QW02	1	1	1	1	1	BA10001020	Semicon Composite, UN2214
QW03	1	1	1	1	1	BA20001020	Semicon Composite, UN2215
PW10-MISCELLANEOUS							
WT01	1	1	1	1	1	YT02020440	Terminal, 2P; RCA Jack
WT02	1	1	1	1	1	YT02020330	Terminal, 2P; RCA Jack
WT03	1	1	1	1	1	YT02020420	Terminal, 2P; RCA Jack
WT03	1	1	1	1	1	YT02020330	Terminal, 2P; RCA Jack
PX20-IN/OUT CIRCUIT BOARD							
PX20	1	1	1	1	1	WB106K2440	P.W. Board, IN/OUT
	1	1	1	1	1	ZZ106K2440	P.W. Board Assembly
SX01	1	1	1	1	1	SP01010800	Push Switch, Tack
PY20-DISPLAY CIRCUIT BOARD							
PY20	1	1	1	1	1	WB106K2410	P.W. Board, Display
	1	1	1	1	1	ZZ106K2410	P.W. Board Assembly
PY20-CAPACITORS							
CY01	1	1	1	1	1	OA10505010	Elect 1 μ F 50V
CY02	1	1	1	1	1	DK46223300	Ceramic 0.022 μ F \pm 10%

REF. DESIG.	Q'TY					PART NO.	DESCRIPTION
	U	N	A	P	F		
PY20-RESISTORS (All Resistors are \pm 5% & 1/8W)							
RY01	1	1	1	1	1	RI05472180	4.7K Ω , Chip
RY02	1	1	1	1	1	RI05472180	4.7K Ω , Chip
RY03	1	1	1	1	1	RI05472180	4.7K Ω , Chip
RY04	1	1	1	1	1	RI05472180	4.7K Ω , Chip
RY05	1	1	1	1	1	RI05472180	4.7K Ω , Chip
RY06	1	1	1	1	1	RI05472180	4.7K Ω , Chip
RY07	1	1	1	1	1	RI05472180	4.7K Ω , Chip
RY08	1	1	1	1	1	RI05472180	4.7K Ω , Chip
RY09	1	1	1	1	1	RI05472180	4.7K Ω , Chip
RY10	1	1	1	1	1	RI05472180	4.7K Ω , Chip
RY13	1	1	1	1	1	RI05472180	4.7K Ω , Chip
RY14	1	1	1	1	1	RI05473180	47K Ω , Chip
RY15	1	1	1	1	1	RI05103180	10K Ω , Chip
RY16	1	1	1	1	1	RI05103180	10K Ω , Chip
RY17	1	1	1	1	1	RI05102180	1K Ω , Chip
RY18	1	1	1	1	1	RI05102180	1K Ω , Chip
RY19	1	1	1	1	1	RI05222180	2.2K Ω , Chip
RY20	1	1	1	1	1	RI05222180	2.2K Ω , Chip
RY21	1	1	1	1	1	BW05154010	150K Ω x 8, Composite
RY22	1	1	1	1	1	BW05154010	150K Ω x 8, Composite
RY23	1	1	1	1	1	BW05154020	150K Ω x 10, Composite
RY30	1	1	1	1	1	GD05392140	3.9K Ω $\frac{1}{4}$ W
PY20-SEMICONDUCTORS							
DY01	1	1	1	1	1	HD20001000	Diode 1S1555
QY01	1	1	1	1	1	HC10106060	IC μ PD1510AC
QY02	1	1	1	1	1	HC10104260	IC MSL918RS
QY03	1	1	1	1	1	HC10104260	IC MSL918RS
QY04	1	1	1	1	1	HC10104260	IC MSL918RS
QY05	1	1	1	1	1	HT327852A0	Transistor 2SC2785(RF,JF)
QY06	1	1	1	1	1	HT327852A0	Transistor 2SC2785(RF,JF)
QY07	1	1	1	1	1	HT111752A0	Transistor 2SA1175(RF,JF)
QY08	1	1	1	1	1	HT111752A0	Transistor 2SA1175(RF,JF)
PY20-MISCELLANEOUS							
JY03	1	1	1	1	1	YP06002540	Plug, 4P
SY01	1	1	1	1	1	SP01010800	Push Switch, Tact
SY12	12	12	12	12	12	SP01010800	Push Switch, Tact
VY01	1	1	1	1	1	HQ30801060	Display Unit
PZ20-SENSOR CIRCUIT BOARD							
PZ20	1	1	1	1	1	WB106K2430	P.W. Board, Sensor
	1	1	1	1	1	ZZ106K2430	P.W. Board Assembly
PZ20-CAPACITORS							
CZ01	1	1	1	1	1	DK46333300	Ceramic 0.033 μ F \pm 10%,Chip
CZ02	1	1	1	1	1	DK46472300	Ceramic 4700pF \pm 10%,Chip
CZ03	1	1	1	1	1	EJ10601610	Elect 10 μ F 16V
CZ04	1	1	1	1	1	EJ47502510	Elect 4.7 μ F 25V
CZ05	1	1	1	1	1	EJ10601610	Elect 10 μ F 16V
CZ06	1	1	1	1	1	EJ47601610	Elect 47 μ F 16V

REF. DESIG.	Q'TY					PART NO.	DESCRIPTION
	U	N	A	P	F		
RZ01	1	1	1	1	1	RI05224180	PZ20-RESISTORS 220K Ω \pm 5% 1/8W,Chip
RZ02	1	1	1	1	1	RI05120180	12 Ω \pm 5% 1/8W,Chip
RZ03	1	1	1	1	1	RI05102180	1K Ω \pm 5% 1/8W,Chip
DZ01	1	1	1	1	1	HI60001060	PZ20-SEMICONDUCTORS L.E.D. PH302
QZ01	1	1	1	1	1	HC10071060	IC μ PC1373H
LZ01	1	1	1	1	1	LA74020010	PZ20-MISCELLANEOUS Antenna Coil, 5mH
PT51	1	1	1	1	1	YF113K1210 ZZ113K1210	PT51-CARBON CONTACT CIRCUIT BOARD P.W. Board, Carbon Contact P.W. Board Assembly
CT51	1	1	1	1	1	DK16121300	PT51-CAPACITORS Ceramic 120pF \pm 10%
CT52	1	1	1	1	1	DK16471300	Ceramic 470pF \pm 10%
CT53	1	1	1	1	1	OA47405010	Elect 0.47 μ F 50V
RT51	1	1	1	1	1	GD05102140	PT51-RESISTORS 1K Ω \pm 5% $\frac{1}{4}$ W
RT52	1	1	1	1	1	GD05022140	2.2 Ω \pm 5% $\frac{1}{4}$ W

REF. DESIG.	Q'TY					PART NO.	DESCRIPTION
	U	N	A	P	F		
QT51	1	1	1	1	1	HI10030020	PT51-SEMICONDUCTORS L.E.D. LN224RP
QT52	1	1	1	1	1	HI20003320	L.E.D. GL-521
QT53	1	1	1	1	1	HI20003320	L.E.D. GL-521
QT54	1	1	1	1	1	HT320011K0	Transistor Diode Drive
QT55	1	1	1	1	1	HC10070060	IC μ PD6102G
DT51	1	1	1	1	1	HD20001210	Diode 1S2473
DT52	1	1	1	1	1	HD20001210	Diode 1S2473
DT53	1	1	1	1	1	HD20001210	Diode 1S2473
DT54	1	1	1	1	1	HD20001210	Diode 1S2473
DT55	1	1	1	1	1	HD20001210	Diode 1S2473
FT51	1	1	1	1	1	FQ04003020	PT51-MISCELLANEOUS Ceramic Vibrator, 400kHz
PT52	1	1	1	1	1	YF113K1220 ZZ113K1220	PT52-SWITCH CIRCUIT BOARD P.W. Board, Switch P.W. Board Assembly
ST51	1	1	1	1	1	SS01020510	Slide Switch, ON/OFF

(W01-99)	Assembly and Wiring
(T01-99)	Adjustment
(X01-00)	Correction

NOTE ON SAFETY:
 SYMBOL \triangle FIRE OR ELECTRICAL SHOCK HAZARD. ONLY ORIGINAL PARTS SHOULD BE USED TO REPLACE ANY PART MARKED WITH SYMBOL \triangle . ANY OTHER COMPONENT SUBSTITUTION (OTHER THAN ORIGINAL TYPE) MAY INCREASE RISK OF FIRE OR ELECTRICAL SHOCK HAZARD.

18. SPECIFICATIONS

AUDIO PERFORMANCE

Number of Channels	2
Frequency Range	4 – 20,000 Hz
Dynamic Range	> 90 dB
Signal-to-Noise Ratio	> 90 dB
Total Harmonic Distortion (incl. noise)	< 0.003 %
Wow and Flutter	quartz crystal precision
D/A Conversion	16 bit with digital filtering
Error Correction System	Cross Interleave Reed Solomon Code (CIRC)
Audio Output Level	2 V rms

OPTICAL READOUT SYSTEM

Laser	semi-conductor AlGaAs
Wave length	0.78 μ m

SIGNAL FORMAT

Sampling Frequency	44.1 kHz
Quantization	16 bit linear/channel

DISC

Diameter	120 mm
Thickness	1.2 mm
Sense of rotation (seen from reading side)	anti-clockwise
Scanning Velocity	1.2 – 1.4 m/s
Rotation Speed	500 – 200 rpm
Playing Time (max)	60 min (stereo)
Track Pitch	1.6 μ m
Material	plastic

POWER SUPPLY

Mains Voltage	see type plate at the rear panel of the player
Material/finish	polystyrene with extruded aluminium profiles
This model is convertible to 110/120/220/240 volts by changing voltage selector on the rear panel.	
Mains Frequencies	50 and 60 Hz
Power Consumption	32 W approx
Safety Requirements	IEC

CABINET, GENERAL

Dimensions (W × H × D)	
with drawer closed	416 × 90 × 300 mm
with drawer open	416 × 90 × 440 mm
Weight	9.2 kg approx
Connection Cable	fitted with moulded RCA plugs

Specifications and appearance are subject to change modification without notice.