

Service Manual

74CDR1/01G

Compact Disc Recorder

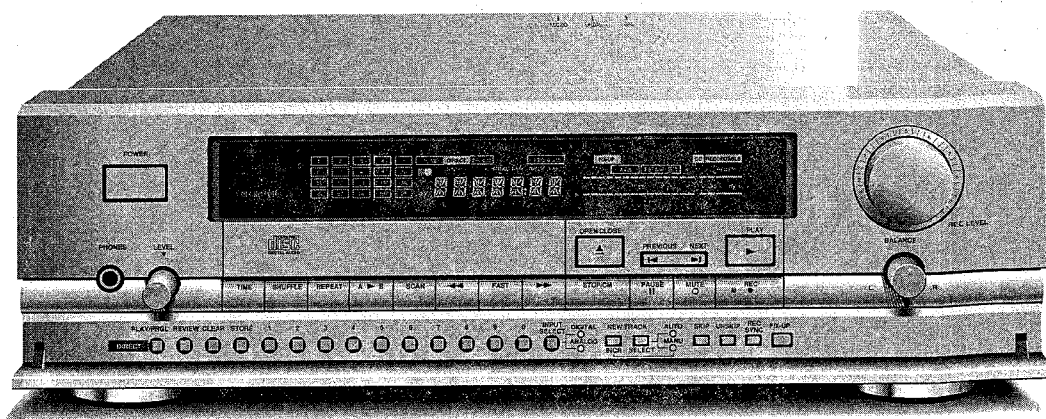

TABLE OF CONTENTS

SECTION	PAGE
1. Warnings	1
2. Technical specifications	2-4
3. Controls and connections	5
4. Dismantling instructions	6-9
5. Servicing hints	9
6. Block diagram	10
7. Wiring diagram	12
8. Circuit diagrams and printed boards	13
8.1. Power supply circuit diagram and p.c.b.	14-17
8.2. Servo circuit diagrams and p.c.b.	18-21
8.3. WOSP circuit diagrams and p.c.b.	22-25
8.4. Encoder circuit diagrams and p.c.b.	26-29
8.5. Decoder circuit diagrams and p.c.b.	30-31
8.6. BS DAC circuit diagram and p.c.b.	32-33
8.7. Control & display circuit diagrams and p.c.b.	34-35
8.8. XLR circuit diagram and p.c.b.	36
8.9. Headphone circuit diagram and p.c.b.	36
8.10. Level and balance circuit diagram and p.c.b.	36
8.11. Level detection circuit diagram	38
9. Start up procedure	41
10. Faultfinding diagnosis	42-44
10. Exploded views and mechanical partslists	45
11. Electrical partslist	45

marantz®

model CDR1

First issue: 1991

4822 725 24002

MZ 3066

MARANTZ DESIGN AND SERVICE

Using superior design and selected high grade components, MARANTZ company has created the ultimate in stereo sound.

Only **original MARANTZ parts** can insure that your MARANTZ product will continue to perform to the specifications for which it is famous.

Parts for your MARANTZ equipment are generally available to our National Marantz Subsidiary or Agent.

ORDERING PARTS:

Parts can be ordered either by mail or by telex. In both cases, correct part number has to be specified. The following information must be supplied to eliminate delays in processing your order:

1. Complete address
2. Complete part numbers and quantities required
3. Description of parts
4. Model number for which part is required
5. Way of shipment
6. Signature: any order form or telex must be signed otherwise such part order will be considered as null and void.

MARANTZ INTERNATIONAL

Vestdijk 9
5600 MD Eindhoven
The Netherlands
Phone: +31/40.758290
Telefax: +31/40.75.82.99
Telex: 35000 PHTC NL routing IND NLMTFAT

PARTS ORDERING

Parts may be ordered at the following addresses:

AUSTRIA
MARANTZ
Hietzinger Kai 137a
1130 Wien

BELGIUM
SVD DIVISION MARANTZ
Industrialaan 1
1720 Groot-Bijgaarden
Belgium
Telex: 24466

CHILE
MARANTZ
DIVISION OF PHILIPS S.A.
AV. Santa Maria, 0760
Casilla 2687
Santiago
Telex: 240.239

DENMARK
MARANTZ
Horsvinget 5
2630 Tastrup

NORWAY
MARANTZ
Postboks 7034
Assiden
3007 Drammen

FRANCE
MARANTZ FRANCE
4 Rue Bernard Palissy
92600 Asnières
France
Telex: 611651

GERMANY
MARANTZ GERMANY GmbH
Alexanderstrasse 1
2000 Hamburg
Germany

THE NETHERLANDS
Elpro Marantz
Wint Hontiaan 28
3526 KV Utrecht
The Netherlands
Telex: 4748

SWEDEN
MARANTZ
Box 1324
171 25 Solna

FINLAND
MARANTZ
Kuortanegatan 1
00520 Helsingfors 52

GREAT BRITAIN
MARANTZ HiFi U.K. Ltd
Kingsbridge House
Padbury oaks
575-583 Bath Road
Long ford
Middlesex UB7 0EH
Faxnr.: 0753 680 428

GREECE
SHERTON ELECTRONICS S.A.
P.O.Box 21025
Hippocrates Street 188
Athens 11471
Greece
Telex: 216.795

JAPAN
MARANTZ JAPAN, Inc.
35-1, 7-chome, Sagamino
Sagamihara-shi, Kanagawa
Japan

KUWAIT
AL ALAMIAH ELECTRONICS
Ussama Building
Fahd al Saleem Street
P.O.Box 23781
Safat-Kuwait
Telex: 22694

ITALY
MARANTZ ITALIANA S.P.A.
Via Chiese, 74
20126 Milano
Italy

SAUDI ARABIA
AL ALAMIAH ELECTRONICS
P.O.Box 5954
University Street
Riyadh 11432
Saudi Arabia
Telex: 401530

SOUTH AFRICA
MARANTZ
DIVISION OF PHILIPS S.A.
Main Road Martindale
P.O. Box. 58088
Newville 21114
South Africa

SPAIN
Euroservice S.A.
Bernardo obrégón, 26
28012 Madrid
faxnr.: 3412 306 198

SWITZERLAND
MARANTZ
Technischer Service
Duenstrasse 3
3186 Dúdingen
Switzerland

TURKEY
DOGRUOL Ltd.
I.M.C.
6 Blok N°6310
Unkapani
Istanbul
Turkey
Telex: 22085

MALTA
CACHIA & GALEA
Republic Street. 68D
Valetta
Telex: 1682

PORTUGAL
MARANTZ
Divisao philips S.A. service
Outurela-carnaxide
2795 LinDA-A-VELHA
Telex: 43906

All of the above locations are fully equipped to take care of your total service needs. Because various countries have differing configuration requirements, it is necessary that you contact the service facility in your particular country. In the event that there is no service location listed for your country, please, contact the nearest facility for the necessary assistance.

In case of difficulties, do not hesitate to contact the Technical Department at abovementioned address.

(GB) WARNING

All ICs and many other semi-conductors are susceptible to electrostatic discharges (ESD). Careless handling during repair can reduce life drastically.

When repairing, make sure that you are connected with the same potential as the mass of the set via a wrist wrap with resistance. Keep components and tools also at this potential.

ESD**(NL) WAARSCHUWING**

Alle IC's en vele andere halfgeleiders zijn gevoelig voor electrostatische ontladingen (ESD).

Onzorgvuldig behandelen tijdens reparatie kan de levensduur drastisch doen verminderen. Zorg ervoor dat u tijdens reparatie via een polsband met weerstand verbonden bent met hetzelfde potentiaal als de massa van het apparaat.

Houd componenten en hulpmiddelen ook op ditzelfde potentiaal.

(F) ATTENTION

Tous les IC et beaucoup d'autres semi-conducteurs sont sensibles aux décharges statiques (ESD).

Leur longévité pourrait être considérablement écourtée par le fait qu'aucune précaution n'est prise à leur manipulation.

Lors de réparations, s'assurer de bien être relié au même potentiel que la masse de l'appareil et enfilez le bracelet serti d'une résistance de sécurité.

Veillez à ce que les composants ainsi que les outils que l'on utilise soient également à ce potentiel.

(D) WARNUNG

Alle ICs und viele andere Halbleiter sind empfindlich gegen elektrostatische Entladungen (ESD).

Unvorsichtige Behandlung bei der Reparatur kann die Lebensdauer drastisch vermindern. Sorgen sie dafür, dass Sie im Reparaturfall über ein Pulsarmband mit Widerstand mit dem Massepotential des Gerätes verbunden sind. halten Sie Bauteile und Hilfsmittel ebenfalls auf diesem Potential.

(I) AVVERTIMENTO

Tutti IC e parecchi semi-conduttori sono sensibili alle scariche statiche (ESD).

La loro longevità potrebbe essere fortemente ridatta in caso di non osservazione della più grande cauzione alla loro manipolazione. Durante le riparazioni occorre quindi essere collegato allo stesso potenziale che quello della massa dell'apparecchio tramite un braccialetto a resistenza.

Assicurarsi che i componenti e anche gli utensili con quali si lavora siano anche a questo potenziale.

(GB)

Safety regulations require that the set be restored to its original condition and that parts which are identical with those specified be used.

(NL)

Veiligheidsbepalingen vereisen, dat het apparaat in zijn oorspronkelijke toestand wordt teruggebracht en dat onderdelen, identiek aan de gespecificeerde worden toegepast.

(S) Varo!

Avattaessa ja suojalukitus ohitettaessa olet alttiina näkymättömälle lasersäteilylle. Älä katso säteeseen.

(D)

Bei jeder Reparatur sind die geltenden Sicherheitsvorschriften zu beachten. Der Originalzustand des Geräts darf nicht verändert werden für Reparaturen sind Original-Ersatzteile zu verwenden.

(I)

Le norme di sicurezza esigono che l'apparecchio venga rimesso nelle condizioni originali e che siano utilizzati pezzi di ricambio identici a quelli specificati.

(SF) Varning!

Osynlig laserstrålning när denna del är öppnad och spärren är urkopplad. Betrakta ej strålen.

(F)

Les normes de sécurité exigent que l'appareil soit remis à l'état d'origine et que soient utilisées les pièces de rechange identiques à celles spécifiées.

"Pour votre sécurité, ces documents doivent être utilisés par des spécialistes agréés, seuls habilités à réparer votre appareil en panne".

TECHNICAL SPECIFICATIONS**General**

- | | |
|---------------------------------------|---------------------------------|
| 1. Mains voltage /01G | : 110V-127V-220V ($\pm 10\%$) |
| 2. Mains frequency | : 50 Hz |
| 3. Power consumption mains, operating | : 40 W |
| 4. Inclination | : max. 10° |

Dimensions and weight

- | | |
|--------------------------|--------------------------------|
| 1. Apparatus tray closed | : WxDxH 420 x 330 x 121/141 mm |
| 2. Apparatus tray open | : WxDxH 420 x 475 x 121/141 mm |
| 3. Weight | : 9,9 kg |

Optical read-out system

- | | |
|---------------------------------|---|
| 1. Laser type | : Semiconductor |
| 2. Wavelength | : 780 nm ± 15 nm |
| 3. Light output | : |
| (Total amount out of objective) | |
| During playing | : max. 0,9 mW min. 0,7 mW |
| During recording | : 14 mW (Peak)
11 mW (Writing level) |

PLAYBACK**Unbalanced output**

- | | |
|--------------------------------------|---|
| 1. Output voltage | : 2 Vrms $\pm 1,5$ dB |
| 2. Unbalance | : max. 0,85dB |
| 3. Output impedance | : 200 Ω |
| 4. Amplitude linearity | : max. $\pm 0,05$ dB from 20Hz to 20kHz |
| 5. Phase linearity | : max. 0,6° from 20Hz to 20kHz |
| 6. Signal to noise ratio | : min. 95dB (A-wtg) |
| 7. Dynamic range | : min. 88dB from 20Hz to 20kHz |
| 8. Total harmonic distortion + noise | : min. 84dB from 20Hz to 20kHz |
| 9. Outband attenuation | : min. 60dB above 25kHz |
| 10. Channel separation | : min. 88dB from 20Hz to 20kHz |
| 11. Muting during random access | : min. 90dB |

Balanced Output (XLR output)

- | | |
|--------------------------------------|--|
| 1. Output voltage | : 3 Vrms $\pm 0,1$ dB |
| 2. Unbalance | : max. 0,2dB |
| 3. Output impedance | : 100 Ω |
| 4. Amplitude linearity | : max. $\pm 0,5$ dB from 20Hz to 20kHz |
| 5. Signal to noise ratio | : min. 92dB (A-wtg) |
| 6. Dynamic range | : min. 85dB from 20Hz to 20kHz |
| 7. Total harmonic distortion + noise | : min. 80dB from 20Hz to 20kHz |
| 8. Outband attenuation | : min. 60dB above 25kHz |
| 9. Channel separation | : min. 85dB from 20Hz to 20kHz |
| 10. Muting during random access | : min. 86dB |

HEADPHONE

- | | |
|--------------------------------------|--|
| 1. Output voltage | : 0 to 6,5 Vrms ± 2 dB |
| 2. Unbalance | : max. 2dB |
| 3. Output impedance | : 120 Ω |
| 4. Load impedance range | : 8 - 32 - 200 - 600 - 1000 - 2000 Ω |
| 5. Output power | : 0 - 58 mW into 32 Ω (max. 95 mW)
0 - 49 mW into 600 Ω (max. 78 mW)
0 - 88 mW into 120 Ω (max. 140 mW) |
| 5. Signal to noise ratio | : min. 87dB Load 600 Ω |
| 6. Dynamic range | : min. 86dB from 20Hz to 20kHz Load 600 Ω |
| 7. Total harmonic distortion + noise | : min. 80dB from 20Hz to 20kHz Load 600 Ω |
| 8. Channel separation | : min. 65dB from 20Hz to 20kHz Load 600 Ω |
| 9. Phase linearity | : max. $\pm 0,35^\circ$ from 20Hz to 20kHz |

RECORD AND PLAYBACK**Unbalanced input - Unbalanced output**

1. Input sensitivity	: 0,7 Vrms for max. level (0dB on disc) 0,11 Vrms for ref. level (-16dB on disc)
2. Unbalance	: max. 1,5dB
3. Input impedance	: 100k Ω
4. Amplitude linearity	: max. $\pm 0,06$ dB from 20Hz to 20kHz
5. Phase linearity	: max. $\pm 3,85^\circ$ from 20Hz to 20kHz
6. Dynamic range	: min. 90dB (A-wtg)
7. Dynamic range	: min. 84dB from 20Hz to 20kHz
8. Total harmonic distortion + noise	: min. 80dB from 20Hz to 20kHz
9. Outband attenuation	: min. 60dB above 25kHz
10. Channel separation	: min. 80dB from 20Hz to 20kHz

Balanced input - Balanced output

1. Input sensitivity	: 3 Vrms for max. level (0dB on disc) 0,475 Vrms for ref. level (-16dB on disc)
2. Unbalance	: max. 08,5dB
3. Input impedance	: 47k Ω
4. Amplitude linearity	: max. $\pm 0,06$ dB from 20Hz to 20kHz
5. Signal to noise ratio	: min. 85dB (A-wtg)
6. Dynamic range	: min. 84dB from 20Hz to 20kHz
7. Total harmonic distortion + noise	: min. 78dB from 20Hz to 20kHz
8. Outband attenuation	: min. 60dB above 25kHz
9. Channel separation	: min. 75dB from 20Hz to 20kHz

RECORDING**Unbalanced input**

1. Input sensitivity	: 0,7 Vrms for max. level (0dB on disc) 0,11 Vrms for ref. level (-16dB on disc)
2. Unbalance	: max. 0,3dB
3. Amplitude linearity	: max. $\pm 0,01$ dB from 20Hz to 20kHz
4. Phase linearity	: max. $\pm 3,25^\circ$ from 20Hz to 20kHz
5. Signal to noise ratio	: min. 94dB (A-wtg)
6. Dynamic range	: min. 88dB from 20Hz to 20kHz
7. Total harmonic distortion + noise	: min. 84dB from 20Hz to 20kHz
8. Outband attenuation	: min. 86dB from 25kHz to 2,8224MHz
9. Channel separation	: min. 85dB from 20Hz to 20kHz

Balanced input (XLR)

1. Input sensitivity	: 3 Vrms for max. level (0dB on disc) 0,475 Vrms for ref. level (-16dB on disc)
2. Unbalance	: max. 0,65dB
3. Amplitude linearity	: max. $\pm 0,02$ dB from 20Hz to 20kHz
4. Phase linearity	: max. $\pm 4,9^\circ$ from 20Hz to 20kHz
5. Signal to noise ratio	: min. 90dB (A-wtg)
6. Dynamic range	: min. 85dB from 20Hz to 20kHz
7. Total harmonic distortion + noise	: min. 84dB from 20Hz to 20kHz
8. Outband attenuation	: min. 86dB from 25kHz to 2,8224MHz
9. Channel separation	: min. 80dB from 20Hz to 20kHz

Microphone

1. Input sensitivity	: 20 mV for max. level (0dB on disc) 3 mV for ref. level (-16dB on disc)
2. Input impedance	: 10k Ω
3. Microphone impedance range	: 200 - 600 - 2000 Ω
4. Amplitude linearity	: max. ± 1 dB from 20Hz to 20kHz
5. Signal to noise ratio	: min. 80dB (A-wtg)
6. Total harmonic distortion + noise	: min. 65dB from 20Hz to 20kHz
7. Channel separation	: min. 60dB from 20Hz to 20kHz

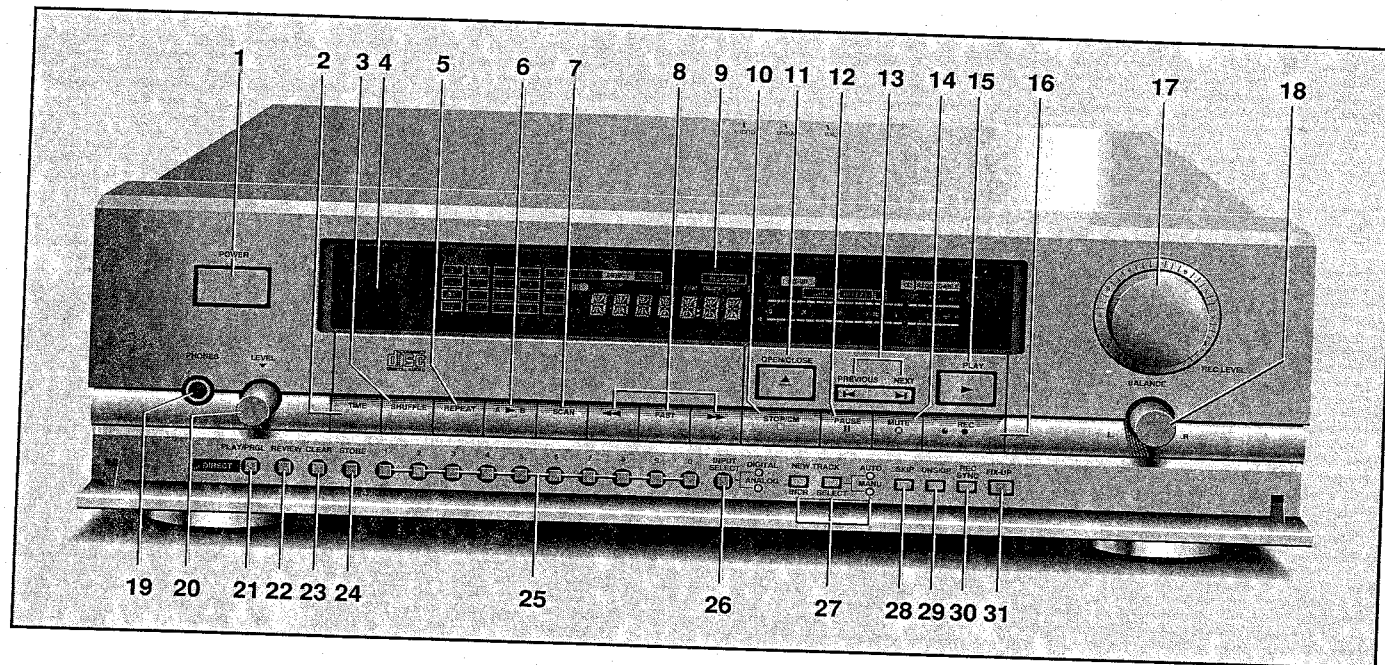

CONTROLS			
Indication on set		Indication in circuit diagram	
1	POWER		
2	TIME		1502
3	SHUFFLE		1837
4	IR SENSOR		1828
5	REPEAT		1802
6	A ▶ B		1819
7	SCAN		1810
8	◀◀ and ▶▶		1844
			1834
		FAST	1843
9	DISPLAY		1846
10	STOP/CM		1805
11	OPEN/CLOSE		1813
12	PAUSE		1812
13	PREVIOUS and NEXT		1822
		PREVIOUS	1821
		NEXT	1830
14	MUTE		1831
15	PLAY		1839
16	RECORD		1840
17	RECORDING LEVEL		3550
18	BALANCE		3551
19	PHONES		1581
20	LEVEL		3582
21	DIRECT PLAY/PROGRAM		1838
22	REVIEW		1829
23	CLEAR		1820
24	STORE		1811
25	1-0 digit keys		
			0 1815
			1 1827
			2 1836
			3 1818
			4 1845
			5 1817
			6 1826
			7 1835
			8 1816
			9 1825
26	INPUT SELECT		1824
27	NEW TRACK		1833
		INCREMENT	1842
		SELECT AUTO/MANUAL	1814
28	SKIP		1823
29	UNSKIP		1832
30	REC SYNC		1816
31	FIX UP		1825

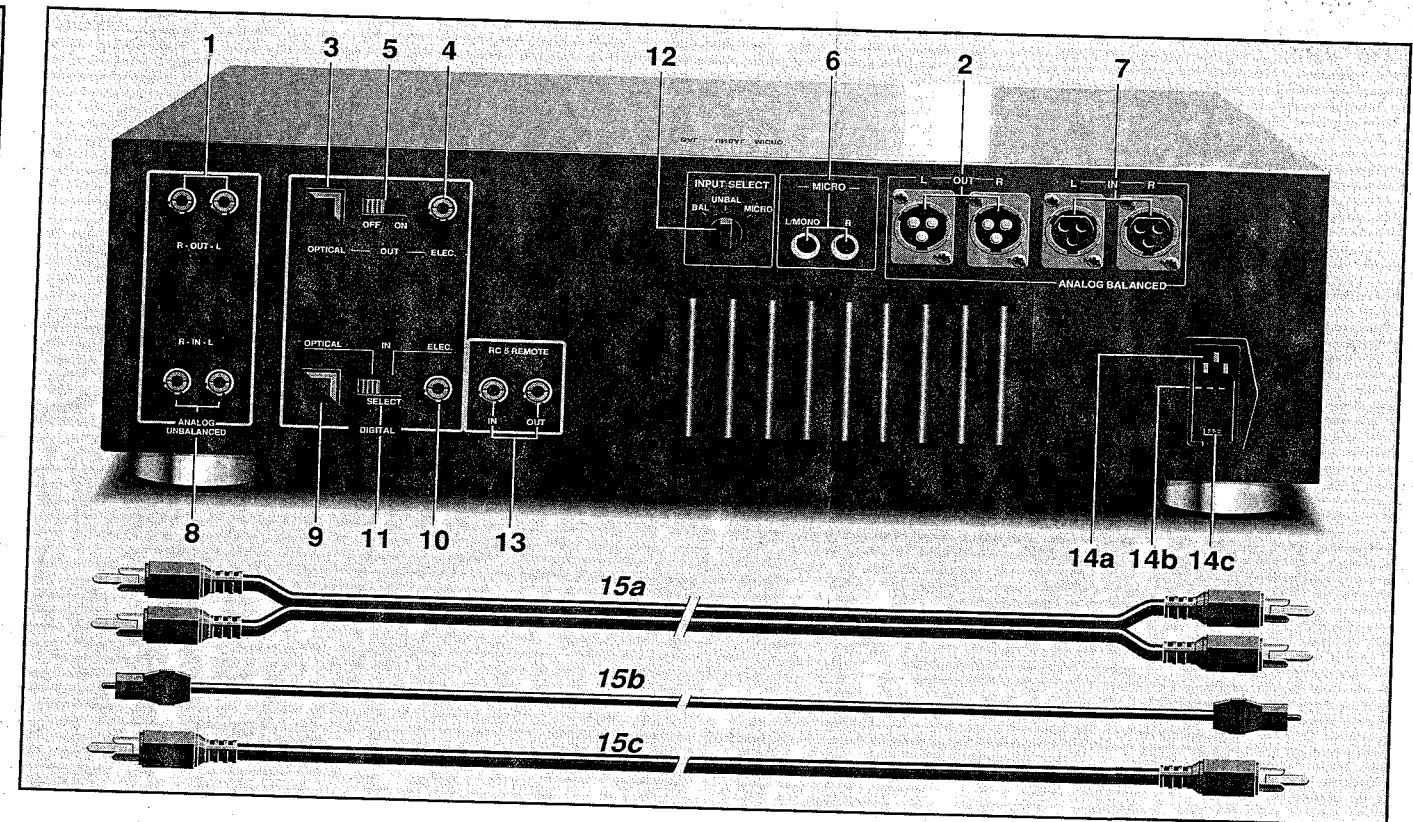

CONNECTIONS		
ANALOG OUTPUTS		
1	ANALOG UNBALANCED OUT	
2	ANALOG BALANCED OUT	1160
		L1351
		R1352
DIGITAL OUTPUTS		
3	DIGITAL OUT OPTICAL	
4	DIGITAL OUT ELECTRICAL (COAXIAL)	1170
5	OFF ON	1161
		1140
ANALOG INPUTS		
6	MICROPHONES	
7	ANALOG BALANCED IN	L1000
		R1001
		L1201
		R1202
		1301
DIGITAL INPUTS		
9	DIGITAL IN OPTICAL	
10	DIGITAL IN ELECTRICAL (COAXIAL)	1420
11	SELECT	1422
		1421
GENERAL CONNECTIONS		
12	INPUT SELECT	
13	RC5 REMOTE	1110
14	a MAINS SOCKET	1423
	b MAINS FUSE HOLDER	
	c VOLTAGE SELECTOR	
15	a 4822 321 22832	
	b 4822 321 23302	

IMPORTANT NOTE ABOUT FIX UP

- If you do not yet wish to store the recording permanently, you can remove the CDR and add to the recording at any time or skip unwanted passages and/or tracks.

- If you do not wish to store anything else on the CDR, you can store the recording permanently by pressing **FIX UP** and then **within 2 seconds REC(ord)**. **FIX UP** lights up on the display: the recording will now be stored. The storing will take 2 minutes and 58 seconds; this will be counted down on the display. The recording has now been stored on the CDR and can **no longer** be changed.

ENCODER - 1

CONN. 1500 TO CONN. 1090 ON DECODER CIRCUIT
CONN. 1501 TO CONN. 1190 ON DECODER CIRCUIT
CONN. 1503 TO CONN. 1603 ON SERVO CIRCUIT
CONN. 1504 TO CONN. 1000 ON WOSP CIRCUIT

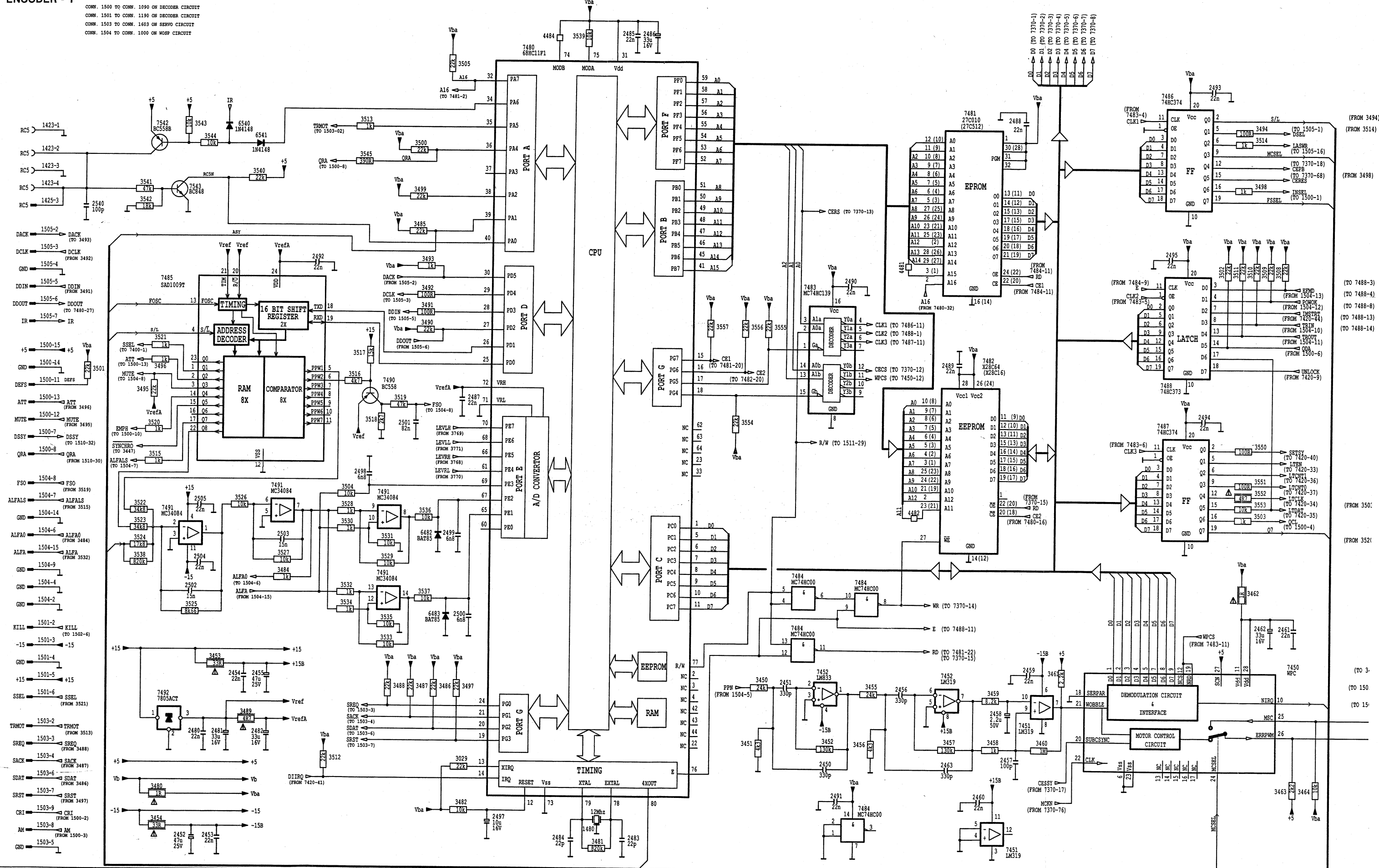

ENCODER PANEL COMPONENT SIDE

1300 F11	2303 F11	2355 E8	2385 B5	2434 D11	2485 D1	2750 E5	3301 F11	3353 G8	3403 E8	3444 D10	3481 C1	3504 D1	3528 F4	3555 D3	3769 E3	6752 E5	7373 C9	7489 F5
1301 F12	2304 F11	2356 E9	2386 D9	2435 D10	2486 C1	2751 E6	3302 F11	3354 G8	3404 E9	3445 D11	3482 C1	3505 D1	3529 F4	3556 D1	3770 E3	6753 E6	7374 D9	7490 F2
1340 F10	2305 G10	2357 F9	2387 D8	2436 E1	2487 D2	2752 E7	3303 F11	3355 G8	3405 E8	3446 D10	3483 C1	3506 D1	3530 F3	3557 D1	3771 D3	6754 E4	7375 D8	7491 F4
1400 E7	2306 F11	2358 F9	2400 E9	2450 B6	2488 F2	2753 E8	3304 F11	3356 G8	3406 E9	3447 D11	3484 C1	3507 D1	3531 F3	3558 D1	3772 D3	6755 D5	7400 E9	7492 B8
1420 D12	2307 F10	2359 F9	2401 E8	2451 B6	2489 E2	2754 E4	3305 F10	3357 B10	3407 E11	3448 D10	3485 B5	3508 D1	3532 F3	3559 F4	3773 D5	6756 F4	7420 B11	7542 B11
1421 D12	2308 F10	2360 F10	2402 E8	2452 C7	2490 C1	2755 D5	3306 F11	3358 D9	3408 E11	3449 D10	3486 B5	3509 D1	3533 F3	3560 F4	3774 D5	6757 D4	7421 B11	7543 B12
1422 C12	2309 F11	2361 F10	2403 E8	2453 B7	2491 C1	2756 E6	3307 G11	3359 D10	3409 E11	3450 D10	3487 B5	3510 D1	3534 F4	3561 F4	3775 D5	6758 E5	7422 C11	7752 E6
1423 B12	2340 E9	2370 B6	2404 E8	2454 B7	2492 F2	2757 E4	3308 F11	3360 D10	3410 E11	3451 C8	3488 E3	3511 D1	3535 F3	3562 F3	3776 D5	6759 E5	7423 D11	7753 D6
1424 C10	2341 F10	2371 B6	2405 E8	2455 B8	2493 F2	2758 E6	3309 F11	3361 D10	3411 E11	3452 B7	3490 B1	3512 D1	3536 F3	3563 F3	3777 D5	6760 E5	7424 D11	7754 E3
1425 A11	2342 E9	2372 B9	2406 E8	2456 B6	2494 F2	2759 E6	3310 F11	3362 D10	3412 E11	3453 B7	3491 B1	3513 D1	3537 F3	3564 F3	3778 D5	6761 F11	7425 C4	7755 D4
1480 C1	2343 F8	2373 C9	2407 E8	2457 D4	2495 D6	2760 E4	3311 F11	3363 D9	3413 E11	3454 B6	3492 B1	3514 D1	3538 F3	3565 F3	3779 D5	6762 E4	7426 D11	
1500 F5	2344 E8	2374 C10	2408 E8	2458 D4	2496 E3	2761 E4	3312 F11	3364 D9	3414 E11	3455 B6	3493 B1	3515 D1	3539 F3	3566 F3	3780 D5	6763 E4	7427 D11	
1501 F6	2345 F10	2375 C10	2409 E8	2459 D4	2497 E3	2762 D5	3313 F11	3365 D9	3415 E11	3456 B6	3494 B1	3516 D1	3540 F3	3567 F3	3781 D5	6764 E4	7428 C2	
1502 B9	2346 F8	2376 D10	2410 E8	2460 D1	2498 D1	2763 D5	3314 F11	3366 D9	3416 E11	3457 B6	3495 B1	3517 D1	3541 F3	3568 F3	3782 E4	6765 E4	7429 C1	
1503 B6	2347 F9	2377 D10	2411 E8	2461 B3	2499 E3	2764 D4	3315 F11	3367 D9	3417 E11	3458 B6	3496 B1	3518 D1	3542 F3	3569 F3	3783 E4	6766 E4	7430 C1	
1504 B4	2348 E8	2378 C9	2412 E8	2462 C3	2500 E3	2765 E3	3316 F11	3368 D9	3418 E11	3459 B6	3497 B1	3519 D1	3543 F3	3570 F3	3784 E4	6767 E4	7431 F1	
1505 B1	2349 F7	2379 C10	2413 E8	2463 B6	2501 E4	2766 E3	3317 F11	3369 D9	3419 E11	3460 B6	3498 B1	3520 D1	3544 F3	3571 F3	3785 E4	6768 E4	7432 D3	
1510 A2	2350 E7	2380 C9	2414 E8	2464 B8	2502 F4	2767 E3	3318 F11	3370 D9	3420 E11	3461 B6	3499 B1	3521 D1	3545 F3	3572 F3	3786 E4	6769 E4	7433 C1	
1511 D2	2351 E10	2381 C10	2415 C11	2481 B8	2503 F4	2768 D3	3319 F11	3371 D9	3421 E11	3462 B6	3500 B5	3522 D1	3546 F3	3573 F3	3787 E4	6770 E4	7434 F1	
2300 E11	2352 E10	2382 D9	2416 C11	2482 D5	2504 F4	2769 D3	3320 F11	3372 D9	3422 E11	3463 B6	3501 B5	3523 D1	3547 F3	3574 F3	3788 E4	6771 E4	7435 F2	
2301 G11	2353 F10	2383 D9	2417 C11	2483 C1	2505 F4	2770 D3	3321 F11	3373 D9	3423 E11	3464 B6	3502 D7	3524 F4	3548 F3	3575 E3	3789 E4	6772 E4	7436 F2	
2302 E11	2354 F8	2384 B5	2418 B11	2484 C1	2540 B12	3300 E11	3352 F10	3402 E9	3443 F11	3480 C7	3503 F3	3525 F4	3549 D3	3576 E3	3790 E4	6773 D10	7437 F2	

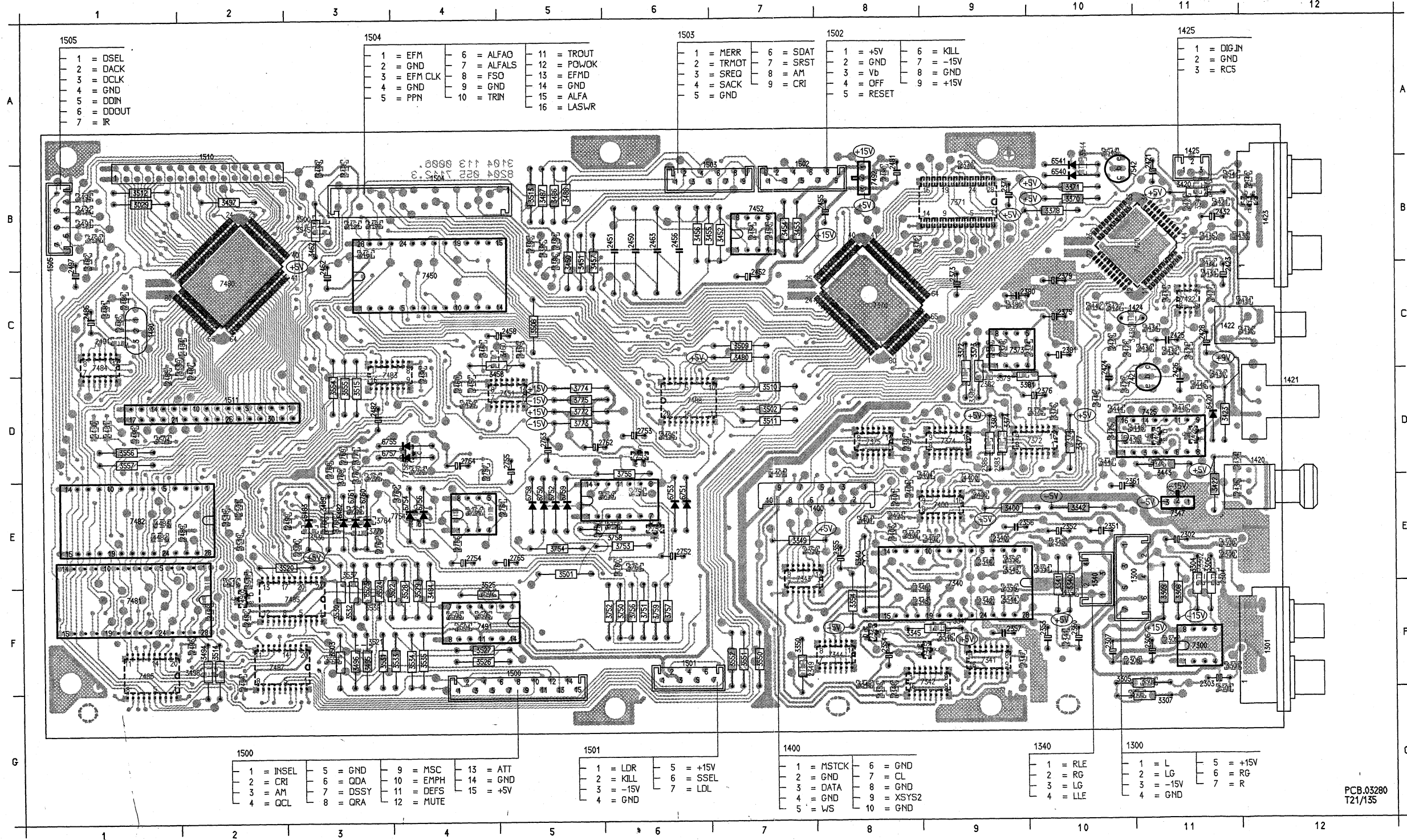

PCB.03280
T21/135

ENCODER PANEL SOLDER SIDE

1300 F11	2303 F11	2355 E8	2385 B5	2434 D11	2485 D1	2750 E5	3301 F11	3353 G8	3403 E8	3444 D10	3481 C1	3504 D1	3529 F4	3555 D3	3769 E3	6752 E5	7373 C3	7489 F5
1301 F12	2304 F11	2356 E9	2386 D9	2435 D10	2486 C1	2751 E6	3302 F11	3354 F8	3404 E9	3445 D11	3482 C1	3505 D2	3530 F3	3556 D1	3770 E3	6753 E6	7374 D8	7490 F2
1340 F10	2305 G10	2357 F9	2387 D8	2436 E11	2487 D2	2752 E6	3303 F11	3370 B10	3420 B11	3446 D11	3484 F4	3506 D3	3531 F3	3557 D1	3771 E3	6754 E4	7375 D8	7491 F4
1400 E7	2306 F11	2358 E9	2400 E9	2450 B6	2488 F2	2753 D6	3304 E11	3371 B10	3421 B11	3447 D10	3485 B3	3507 D4	3532 F3	3558 D2	3772 D5	6755 D3	7400 E9	7492 B8
1420 D12	2307 F10	2359 F9	2401 E8	2451 D6	2489 F3	2754 E4	3305 F10	3372 C9	3422 E11	3448 D10	3486 B5	3508 D5	3533 F4	3559 D3	3773 D5	6756 E4	7420 B11	7542 B11
1421 D12	2308 F10	2360 F10	2402 E8	2452 C7	2490 D4	2755 D5	3306 E11	3373 C9	3423 D11	3449 D10	3488 B5	3509 D6	3534 F4	3560 D4	3774 D5	6757 D5	7421 D11	7543 B12
1422 C12	2309 F11	2361 E10	2403 E8	2453 B7	2491 C1	2756 E4	3307 G11	3374 D8	3424 C11	3450 C5	3489 B5	3510 D7	3535 F4	3561 D5	3775 D5	6758 E5	7422 D11	7544 B12
1423 B12	2340 E9	2370 B9	2404 E8	2454 B7	2492 F2	2757 E4	3308 F11	3375 D10	3425 D11	3451 C5	3490 B1	3511 D8	3536 F3	3562 D6	3776 D5	6759 E5	7423 D11	7545 E3
1424 C10	2341 F10	2371 B9	2405 E8	2455 B8	2493 F2	2758 E6	3309 F11	3376 D10	3426 D11	3452 B7	3491 B1	3512 D8	3537 F3	3563 D6	3777 D5	6760 E3	7424 D11	7546 E3
1425 A11	2342 F9	2372 B9	2406 E8	2456 B6	2494 F2	2759 E5	3310 F11	3377 D10	3427 C10	3453 B7	3492 B1	3513 D5	3538 F3	3564 D6	3778 D5	6761 E3	7425 D11	7547 E3
1480 C1	2343 F8	2373 C9	2422 C11	2457 D4	2495 D6	2760 E4	3311 F10	3378 B10	3428 C10	3454 B7	3493 B1	3514 F2	3539 F3	3565 D6	3779 D5	6762 E3	7426 D11	7548 E3
1500 F5	2344 E9	2374 C10	2423 C11	2458 C5	2496 F5	2761 E5	3312 E10	3379 D10	3429 D10	3455 B7	3494 B1	3515 D3	3540 B11	3566 D6	3780 E6	6763 E3	7427 D11	7549 E3
1501 F6	2345 E10	2375 C10	2424 D10	2459 D4	2497 C1	2762 D5	3313 E9	3380 C9	3430 D11	3456 B5	3495 F2	3516 E2	3541 B11	3567 E6	3781 E6	6764 E3	7428 D11	7550 E3
1502 B7	2346 F8	2376 D10	2425 C11	2460 D4	2498 D1	2763 D5	3314 E9	3381 D8	3431 C11	3457 C5	3496 F2	3517 E2	3542 B11	3568 E6	3782 E6	6765 E3	7429 D11	7551 E3
1503 B6	2347 F9	2377 D10	2426 D11	2461 B3	2499 E3	2764 D4	3315 F8	3382 D8	3432 C11	3458 D4	3497 B2	3518 E2	3543 A10	3569 E6	3783 E6	6766 E3	7430 D11	7552 E3
1504 B4	2348 G8	2378 C9	2427 C11	2462 C3	2500 E3	2765 E5	3316 F9	3383 C9	3433 C11	3459 C5	3498 F2	3519 E2	3544 B11	3570 E6	3784 E3	6767 E3	7431 F9	7553 E3
1505 B1	2349 F7	2379 C10	2428 D10	2463 B6	2501 E2	2766 E5	3317 F9	3384 C9	3434 C11	3460 C5	3499 B3	3520 E2	3545 A10	3571 E6	3785 E3	6768 E3	7432 F8	7554 E3
1510 A2	2350 E7	2380 C9	2429 C10	2464 B8	2502 F4	2767 E5	3318 F8	3385 D8	3435 B11	3461 C4	3500 B3	3521 F3	3546 B10	3572 E6	3786 E3	6769 E3	7433 F8	7555 E3
1511 D2	2351 E10	2381 C10	2430 C10	2465 B8	2503 F4	2768 D3	3319 E7	3386 C5	3436 C12	3462 B3	3501 B3	3522 F4	3547 B3	3573 E6	3787 E3	6770 E3	7434 F8	7556 E3
2300 E11	2352 E10	2382 D9	2431 C11	2466 D3	2504 F4	2769 D3	3320 F7	3387 D8	3437 C11	3463 B3	3502 E5	3523 F4	3548 B3	3574 E3	3788 E3	6771 E3	7435 F8	7557 E3
2301 E11	2353 F10	2383 D9	2432 B11	2467 C1	2505 F4	2809 B1	3321 E10	3388 E9	3438 C10	3464 B3	3503 E5	3524 F4	3549 B3	3575 E3	3789 E3	6772 E3	7436 F8	7558 E3
2302 E11	2354 F8	2384 B5	2433 B11	2468 C1	2540 B12	3300 E11	3352 F10	3402 E9	3443 E11	3480 C7	3504 F3	3525 F4	3550 D3	3768 E3	6751 E6	7372 D10	7488 D6	

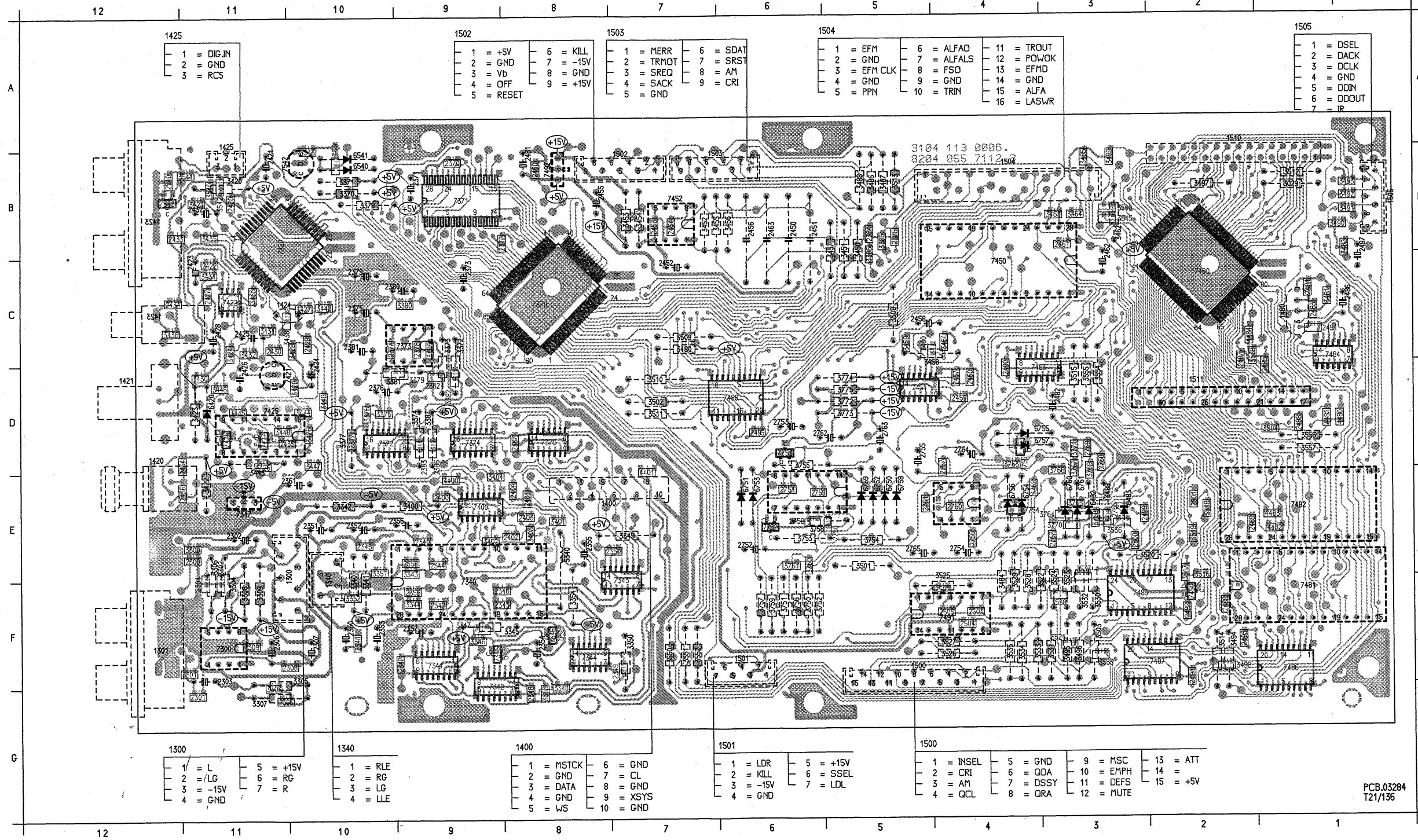

1425

1 = DIG.IN
2 = GND
3 = RCS

1502

1 = +5V	6 = KILL
2 = GND	7 = -15V
3 = Vb	8 = GND
4 = OFF	9 = +15V
5 = RESET	

1503

1 = MERR	6 = SDAT
2 = TRMOT	7 = SRST
3 = SREQ	8 = AM
4 = SACK	9 = CRI
5 = GND	

1504

1 = EFM	6 = ALFAO	11 = TROUT
2 = GND	7 = ALFALS	12 = POWOK
3 = EFM CLK	8 = FSD	13 = EFMK
4 = GND	9 = GND	14 = GND
5 = PPN	10 = TRIN	15 = ALFA
		16 = LASWR

1505

1 = DSEL
2 = DACK
3 = DCLK
4 = GND
5 = DDIN
6 = DDOU
7 = IR

1300

1 = L	5 = +15V
2 = /LG	6 = RC
3 = -15V	7 = R
4 = GND	

1340

1 = RLE
2 = RG
3 = LG
4 = LLE

1400

1 = MSTCK	6 = GND
2 = GND	7 = CL
3 = DATA	8 = GND
4 = GND	9 = XSYS
5 = WS	10 = GND

1501

1 = LDR	5 = +15V
2 = KILL	6 = SSEL
3 = -15V	7 = LDL
4 = GND	

1500

1 = INSEL	5 = GND	9 = MSC	13 = ATT
2 = CRI	6 = ODA	10 = EMPH	14 = +5V
3 = AM	7 = DSSY	11 = DEFS	
4 = QCL	8 = QRA	12 = MUTE	

PCB.03284
T21/136

DECODER PANEL COMPONENT SIDE

1091 B1	2091 C1	2170 C10	2262 D8	3097 B1	3142 E6	3180 E6	3236 C4	3281 C5	3815 E5	4192 D5	7092 C1	9001 C3	9016 B5	9032 B2	9048 D2
1092 D3	2092 C1	2171 C9	2263 E9	3098 C1	3143 D6	3181 B1	3237 B3	3282 F4	3816 B3	4193 F4	7140 D6	9002 B6	9017 C7	9033 C2	9049 D2
1140 D10	2093 C2	2172 C8	2264 B7	3099 C1	3150 C7	3190 C6	3250 B2	3801 B2	3817 C4	4230 B4	7160 B8	9003 D4	9018 E7	9034 E5	9050 E4
1141 F5	2094 B2	2181 E9	2265 B8	3100 C1	3160 B8	3191 D4	3251 E1	3802 E1	3818 B3	4260 C7	7161 B9	9004 C3	9019 C1	9035 B2	9051 E7
1150 C8	2095 E3	2182 E6	2266 D8	3101 E2	3161 B9	3192 B6	3260 B7	3803 E5	3819 C2	4261 C7	7162 C9	9005 B2	9020 B2	9036 B2	9052 D6
1151 D8	2096 F2	2190 D6	2267 E9	3102 B2	3162 D8	3193 E6	3261 F8	3804 B8	3820 C3	4262 C7	7163 D9	9006 E7	9021 B4	9037 B1	9053 E6
1152 B9	2097 B1	2191 D6	2268 B8	3103 B2	3163 C8	3194 F4	3262 B6	3805 D6	3821 B2	4263 C7	7164 B5	9007 D5	9022 B4	9038 E5	9054 B9
1160 B10	2098 C1	2192 D4	2269 D9	3104 C2	3164 B8	3195 E4	3263 F8	3806 C4	3822 C2	4264 E9	7190 B5	9008 E9	9023 D4	9039 C1	9055 E4
1161 E10	2099 C5	2193 E6	2270 D4	3105 B2	3165 B9	3196 E4	3272 C7	3807 E5	3823 D1	4265 B9	7191 E4	9009 F4	9024 D4	9040 E2	9056 E4
1170 D10	2140 E6	2230 C4	3090 B1	3106 B2	3166 C8	3197 E4	3273 D8	3808 D5	3824 C2	4266 C9	7192 E4	9010 E5	9025 B5	9041 E2	9057 C8
1171 E6	2142 E7	2231 B4	3091 B1	3107 C8	3167 C8	3198 E4	3274 C8	3809 C6	3825 D5	4267 B5	7230 C4	9011 C5	9027 E1	9042 D1	9058 C8
1180 E6	2160 B6	2232 C4	3092 C2	3108 B3	3168 B5	3199 E5	3275 C3	3810 D1	3845 D3	4268 B5	7250 C2	9012 E3	9028 D1	9043 D1	9059 D7
1190 C8	2161 B8	2250 C3	3093 B2	3109 B3	3169 B5	3200 B7	3276 C7	3812 E1	4160 B8	4162 B8	7250 B7	9013 B8	9029 C5	9044 D2	9060 D7
1230 B4	2162 C8	2260 B7	3094 B1	3110 D7	3170 D8	3254 B4	3277 D8	3813 C7	4190 D5	4191 D5	7091 E2	9014 D4	9030 C5	9045 D2	9061 E8
2090 B1	2163 C8	2261 B8	3095 B1	3141 D9	3171 D8	3255 C4	3280 B3	3814 C8	4191 D5	7091 E2	7280 D4	9015 D8	9031 C5	9047 D2	9260 E8

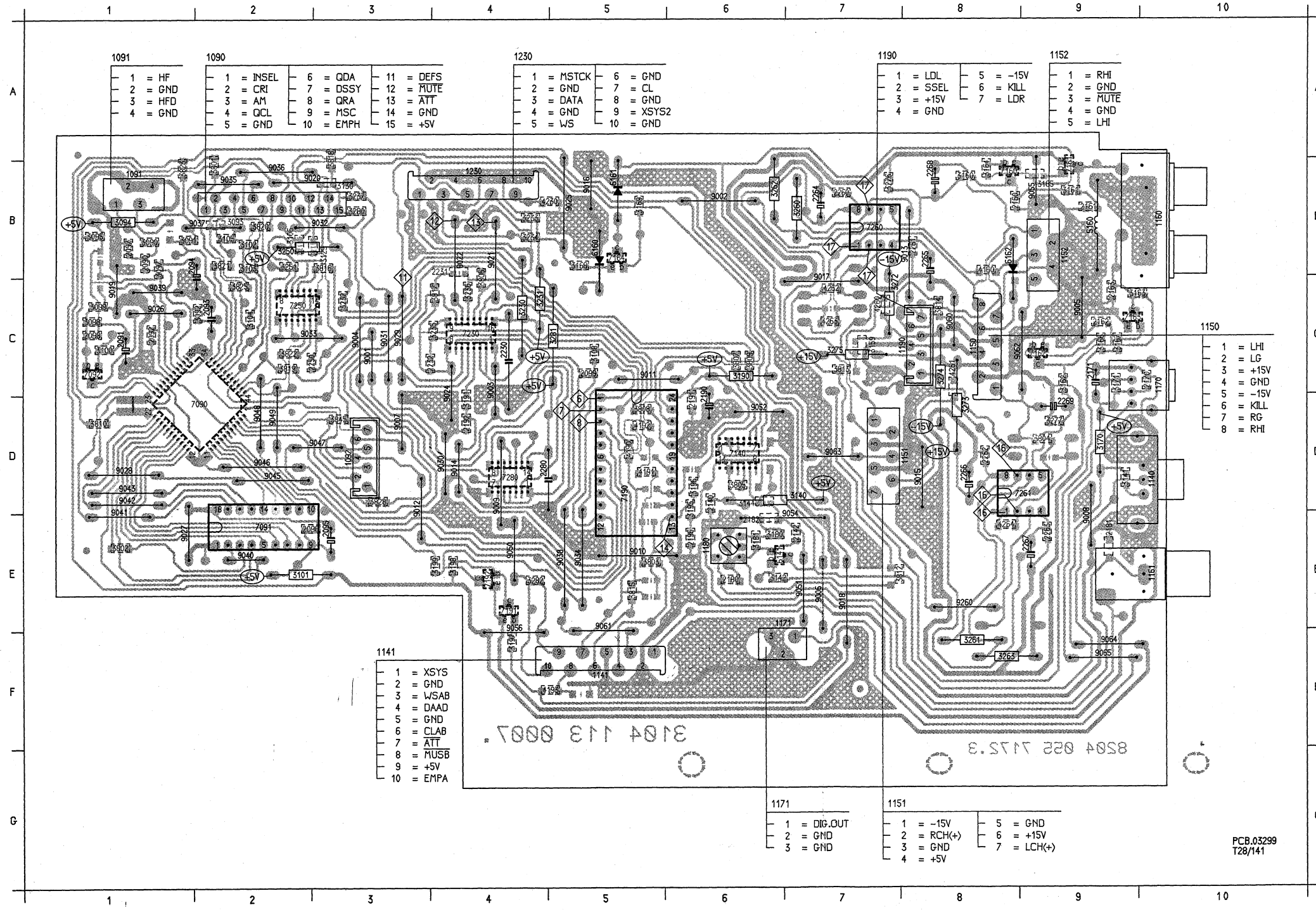

DECODER PANEL SOLDER SIDE

1091 B1	2091 C1	2170 C10	2262 D8	3097 B1	3142 E6	3180 E6	3256 C4	3281 C5	3815 E5	4192 D5	7092 C1	9001 C3	9016 B5	9032 B2	9048 D2
1092 D3	2092 C1	2171 C9	2263 E9	3098 C1	3144 D6	3181 E6	3257 B5	3282 E4	3816 B5	4195 F4	7140 D6	9002 B6	9017 C7	9033 C2	9049 D2
1140 D10	2093 C2	2180 E6	2264 B7	3099 C1	3159 C7	3190 C6	3250 B2	3281 B2	3817 C4	4250 B4	7150 B8	9003 D4	9018 C7	9034 C5	9050 E4
1141 F5	2094 B2	2181 E9	2265 B8	3100 C1	3160 B8	3191 D4	3251 B2	3282 E4	3818 B3	4251 C7	7161 B8	9004 C3	9019 C1	9035 B2	9051 E7
1150 C8	2095 E5	2182 E9	2266 D6	3101 E2	3161 B9	3192 E6	3252 B7	3283 E5	3819 C2	4261 C8	7162 C9	9005 C9	9020 B2	9036 B2	9052 D6
1151 D8	2096 F2	2190 D6	2267 E9	3102 B2	3162 D9	3193 E6	3261 F8	3284 D9	3820 B2	4262 C7	7163 C9	9006 E7	9021 B4	9037 B1	9054 E6
1152 B9	2097 B1	2191 D6	2268 B8	3103 B2	3163 C9	3194 F4	3262 B6	3285 D6	3821 B2	4263 C7	7164 B5	9007 D3	9022 B4	9038 E5	9055 B9
1160 B10	2098 C1	2192 D4	2269 D9	3104 C2	3164 B8	3195 E4	3263 F8	3286 C4	3822 C2	4264 E8	7190 D5	9008 E9	9023 D4	9039 C1	9056 E4
1161 E10	2099 C5	2195 E6	2280 D4	3105 B2	3165 D9	3196 E4	3265 F8	3287 C5	3823 B1	4265 E8	7191 E4	9009 E4	9024 D4	9040 E2	9060 C8
1170 D10	2140 E6	2230 C4	3090 B1	3106 B2	3166 C9	3197 F4	3272 C7	3288 D5	3824 C2	4266 F8	7192 E4	9010 E5	9025 B5	9041 E1	9061 E5
1171 E6	2142 E7	2231 B4	3091 B1	3108 C5	3167 C9	3231 C3	3274 C8	3289 C6	3825 C2	6141 E6	7230 C4	9011 C3	9026 C1	9042 D1	9062 C9
1180 E6	2160 B8	2232 C4	3092 C2	3129 B3	3168 B5	3232 C3	3275 C7	3290 D3	3826 D3	6160 B5	7250 C2	9012 E3	9027 E1	9043 D1	9063 D7
1190 C8	2161 B9	2250 C3	3093 B2	3150 B3	3169 B5	3233 B4	3276 B7	3291 E8	3827 E8	6161 B5	7260 B7	9013 B8	9028 C3	9045 D2	9064 F9
1230 B4	2162 C9	2260 B7	3094 B1	3140 D7	3170 D9	3234 B4	3277 D9	3813 C7	4190 D5	6162 B8	7261 D8	9014 D4	9030 C3	9046 D2	9065 F9
2090 B1	2163 C9	2261 B8	3095 B1	3141 D9	3171 D9	3235 C4	3280 B5	3814 C8	4191 D5	7091 E2	7280 D4	9015 D8	9031 C3	9047 D2	9260 E8

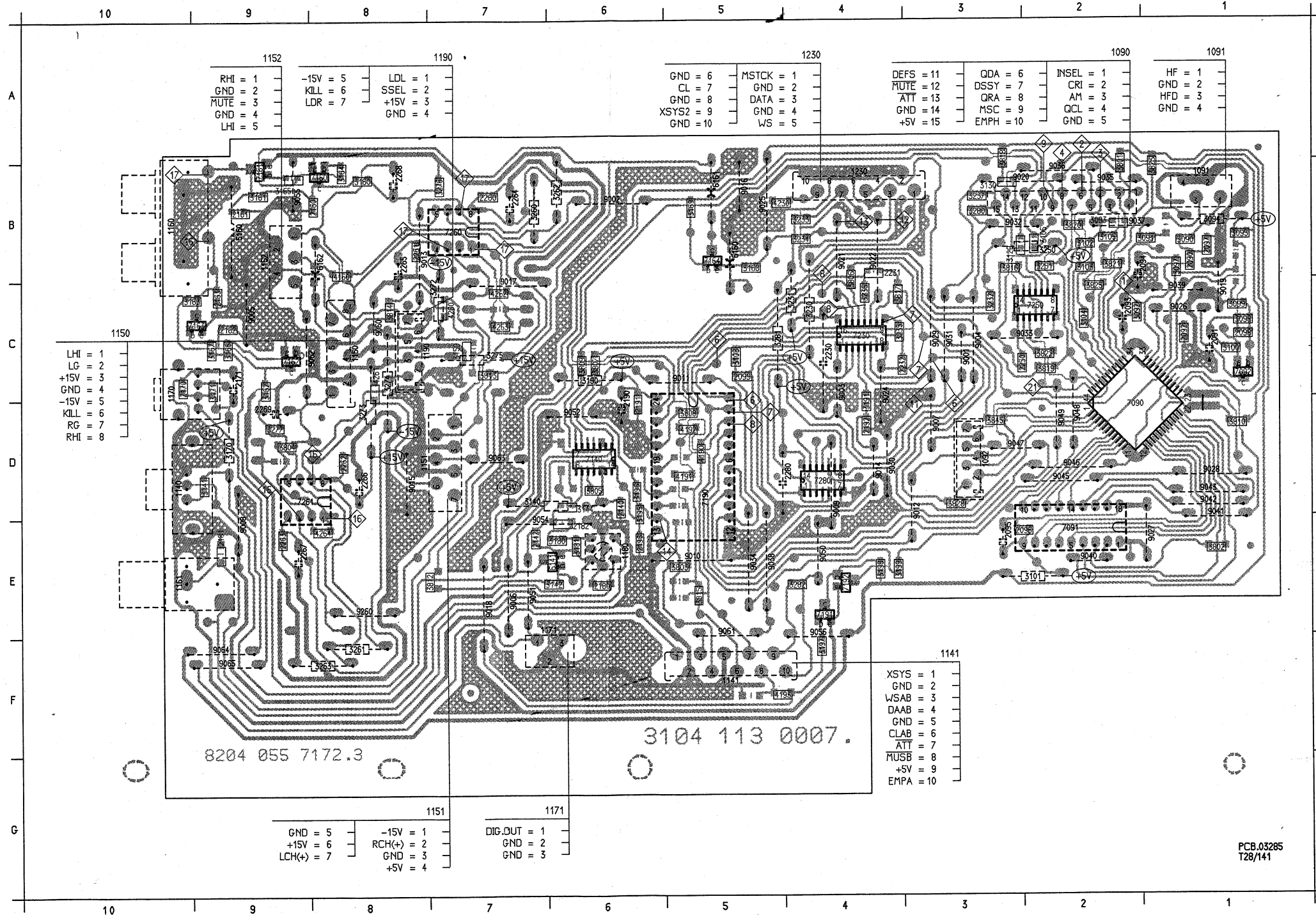

DECODER CIRCUIT DIAGRAM

DECODER - 2

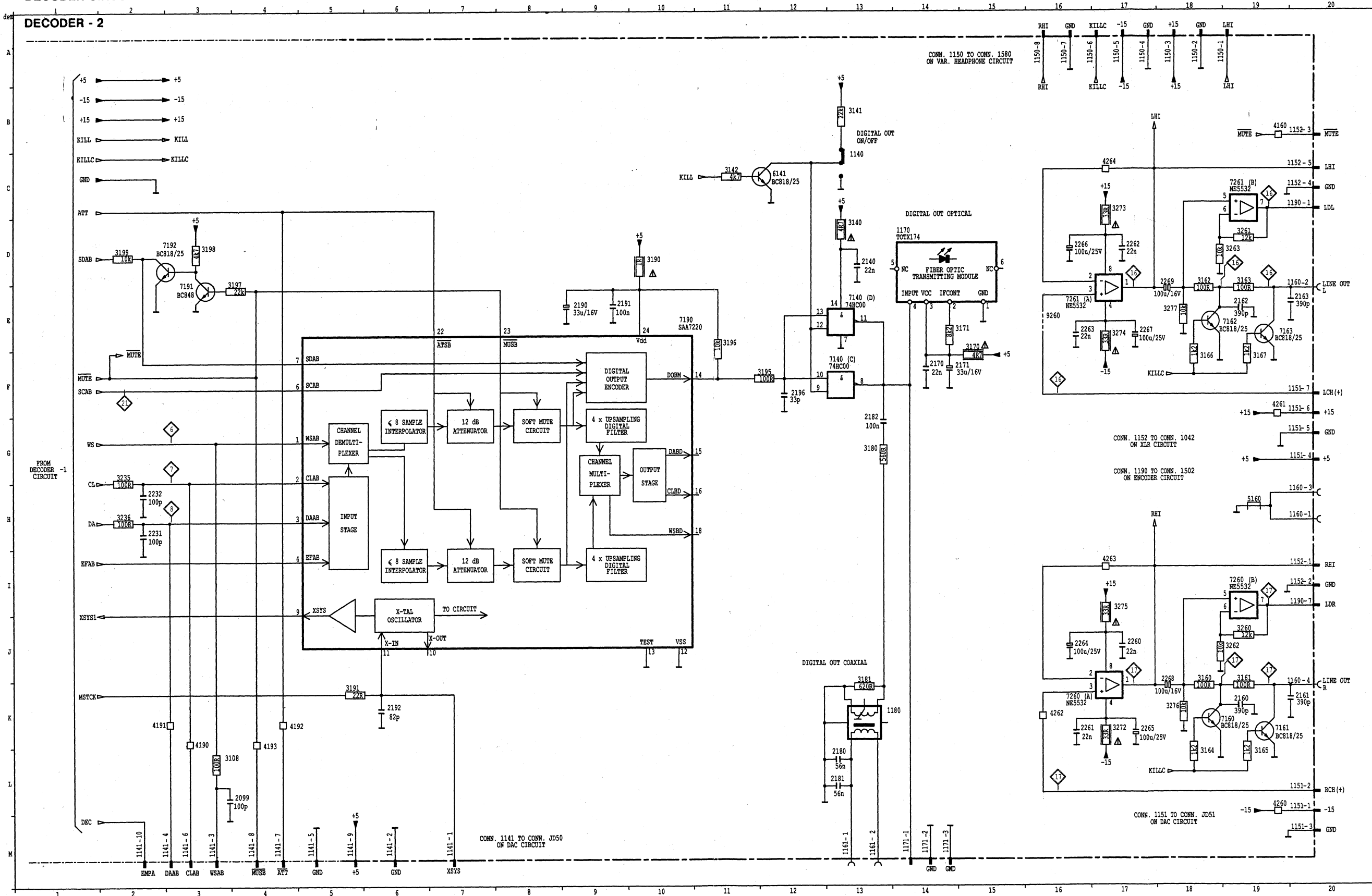

1140 C13
1141 M7
1142 M7
1143 M7
1144 M7
1145 M7
1146 M7
1147 M7
1148 M7
1149 M7
1150 A16
1151 A17
1152 A17
1153 A17
1154 A17
1155 A17
1156 A17
1157 A17
1158 A17
1159 A17
1160 A17
1161 A17
1162 A17
1163 A17
1164 A17
1165 A17
1166 A17
1167 A17
1168 A17
1169 A17
1170 A17
1171 A17
1172 A17
1173 A17
1174 A17
1175 A17
1176 A17
1177 A17
1178 A17
1179 A17
1180 A17
1181 A17
1182 A17
1183 A17
1184 A17
1185 A17
1186 A17
1187 A17
1188 A17
1189 A17
1190 A17
1191 A17
1192 A17
1193 A17
1194 A17
1195 A17
1196 A17
1197 A17
1198 A17
1199 A17
1200 A17
1201 A17
1202 A17
1203 A17
1204 A17
1205 A17
1206 A17
1207 A17
1208 A17
1209 A17
1210 A17
1211 A17
1212 A17
1213 A17
1214 A17
1215 A17
1216 A17
1217 A17
1218 A17
1219 A17
1220 A17
1221 A17
1222 A17
1223 A17
1224 A17
1225 A17
1226 A17
1227 A17
1228 A17
1229 A17
1230 A17
1231 A17
1232 A17
1233 A17
1234 A17
1235 A17
1236 A17
1237 A17
1238 A17
1239 A17
1240 A17
1241 A17
1242 A17
1243 A17
1244 A17
1245 A17
1246 A17
1247 A17
1248 A17
1249 A17
1250 A17
1251 A17
1252 A17
1253 A17
1254 A17
1255 A17
1256 A17
1257 A17
1258 A17
1259 A17
1260 A17
1261 A17
1262 A17
1263 A17
1264 A17
1265 A17
1266 A17
1267 A17
1268 A17
1269 A17
1270 A17
1271 A17
1272 A17
1273 A17
1274 A17
1275 A17
1276 A17
1277 A17
1278 A17
1279 A17
1280 A17
1281 A17
1282 A17
1283 A17
1284 A17
1285 A17
1286 A17
1287 A17
1288 A17
1289 A17
1290 A17
1291 A17
1292 A17
1293 A17
1294 A17
1295 A17
1296 A17
1297 A17
1298 A17
1299 A17
1300 A17
1301 A17
1302 A17
1303 A17
1304 A17
1305 A17
1306 A17
1307 A17
1308 A17
1309 A17
1310 A17
1311 A17
1312 A17
1313 A17
1314 A17
1315 A17
1316 A17
1317 A17
1318 A17
1319 A17
1320 A17
1321 A17
1322 A17
1323 A17
1324 A17
1325 A17
1326 A17
1327 A17
1328 A17
1329 A17
1330 A17
1331 A17
1332 A17
1333 A17
1334 A17
1335 A17
1336 A17
1337 A17
1338 A17
1339 A17
1340 A17
1341 A17
1342 A17
1343 A17
1344 A17
1345 A17
1346 A17
1347 A17
1348 A17
1349 A17
1350 A17
1351 A17
1352 A17
1353 A17
1354 A17
1355 A17
1356 A17
1357 A17
1358 A17
1359 A17
1360 A17
1361 A17
1362 A17
1363 A17
1364 A17
1365 A17
1366 A17
1367 A17
1368 A17
1369 A17
1370 A17
1371 A17
1372 A17
1373 A17
1374 A17
1375 A17
1376 A17
1377 A17
1378 A17
1379 A17
1380 A17
1381 A17
1382 A17
1383 A17
1384 A17
1385 A17
1386 A17
1387 A17
1388 A17
1389 A17
1390 A17
1391 A17
1392 A17
1393 A17
1394 A17
1395 A17
1396 A17
1397 A17
1398 A17
1399 A17
1400 A17
1401 A17
1402 A17
1403 A17
1404 A17
1405 A17
1406 A17
1407 A17
1408 A17
1409 A17
1410 A17
1411 A17
1412 A17
1413 A17
1414 A17
1415 A17
1416 A17
1417 A17
1418 A17
1419 A17
1420 A17
1421 A17
1422 A17
1423 A17
1424 A17
1425 A17
1426 A17
1427 A17
1428 A17
1429 A17
1430 A17
1431 A17
1432 A17
1433 A17
1434 A17
1435 A17
1436 A17
1437 A17
1438 A17
1439 A17
1440 A17

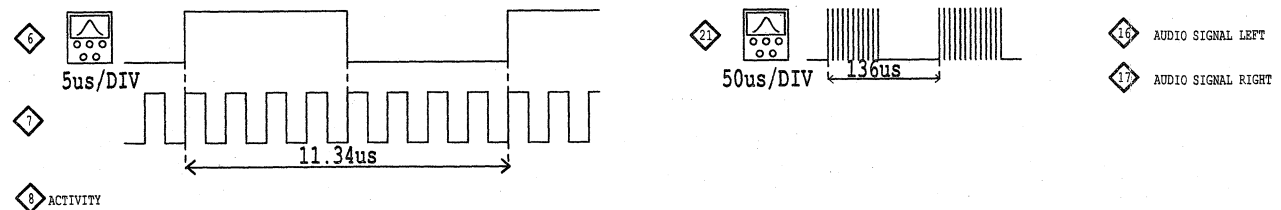

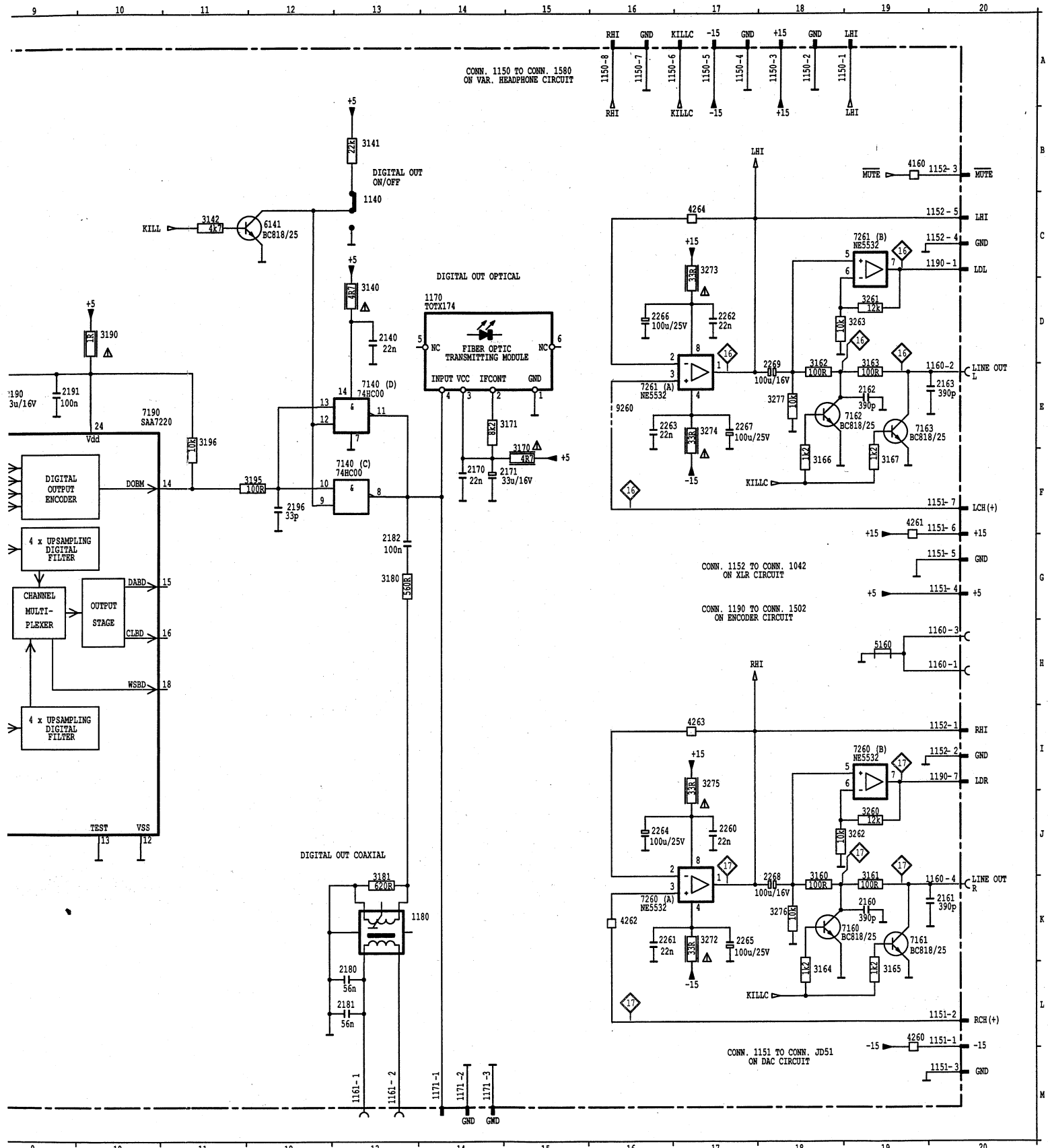

1140	C13
1141	M 2
1142	M 3
1143	M 4
1144	M 5
1145	M 6
1146	M 7
1147	M 8
1148	M 9
1149	M 10
1150	A16
1151	A17
1152	A18
1153	A19
1154	A20
1155	A21
1156	A22
1157	A23
1158	A24
1159	A25
1160	A26
1161	A27
1162	A28
1163	A29
1164	A30
1165	A31
1166	A32
1167	A33
1168	A34
1169	A35
1170	A36
1171	A37
1172	A38
1173	A39
1174	A40
1175	A41
1176	A42
1177	A43
1178	A44
1179	A45
1180	A46
1181	A47
1182	A48
1183	A49
1184	A50
1185	A51
1186	A52
1187	A53
1188	A54
1189	A55
1190	A56
1191	A57
1192	A58
1193	A59
1194	A60
1195	A61
1196	A62
1197	A63
1198	A64
1199	A65
1200	A66
1201	A67
1202	A68
1203	A69
1204	A70
1205	A71
1206	A72
1207	A73
1208	A74
1209	A75
1210	A76
1211	A77
1212	A78
1213	A79
1214	A80
1215	A81
1216	A82
1217	A83
1218	A84
1219	A85
1220	A86
1221	A87
1222	A88
1223	A89
1224	A90
1225	A91
1226	A92
1227	A93
1228	A94
1229	A95
1230	A96
1231	A97
1232	A98
1233	A99
1234	A100
1235	A101
1236	A102
1237	A103
1238	A104
1239	A105
1240	A106
1241	A107
1242	A108
1243	A109
1244	A110
1245	A111
1246	A112
1247	A113
1248	A114
1249	A115
1250	A116
1251	A117
1252	A118
1253	A119
1254	A120
1255	A121
1256	A122
1257	A123
1258	A124
1259	A125
1260	A126
1261	A127
1262	A128
1263	A129
1264	A130
1265	A131
1266	A132
1267	A133
1268	A134
1269	A135
1270	A136
1271	A137
1272	A138
1273	A139
1274	A140
1275	A141
1276	A142
1277	A143
1278	A144
1279	A145
1280	A146
1281	A147
1282	A148
1283	A149
1284	A150
1285	A151
1286	A152
1287	A153
1288	A154
1289	A155
1290	A156
1291	A157
1292	A158
1293	A159
1294	A160
1295	A161
1296	A162
1297	A163
1298	A164
1299	A165
1300	A166
1301	A167
1302	A168
1303	A169
1304	A170
1305	A171
1306	A172
1307	A173
1308	A174
1309	A175
1310	A176
1311	A177
1312	A178
1313	A179
1314	A180
1315	A181
1316	A182
1317	A183
1318	A184
1319	A185
1320	A186
1321	A187
1322	A188
1323	A189
1324	A190
1325	A191
1326	A192
1327	A193
1328	A194
1329	A195
1330	A196
1331	A197
1332	A198
1333	A199
1334	A200
1335	A201
1336	A202
1337	A203
1338	A204
1339	A205
1340	A206
1341	A207
1342	A208
1343	A209
1344	A210
1345	A211
1346	A212
1347	A213
1348	A214
1349	A215
1350	A216
1351	A217
1352	A218
1353	A219
1354	A220
1355	A221
1356	A222
1357	A223
1358	A224
1359	A225
1360	A226
1361	A227
1362	A228
1363	A229
1364	A230
1365	A231
1366	A232
1367	A233
1368	A234
1369	A235
1370	A236
1371	A237
1372	A238
1373	A239
1374	A240
1375	A241
1376	A242
1377	A243
1378	A244
1379	A245
1380	A246
1381	A247
1382	A248
1383	A249
1384	A250
1385	A251
1386	A252
1387	A253
1388	A254
1389	A255
1390	A256
1391	A257
1392	A258
1393	A259
1394	A260
1395	A261
1396	A262
1397	A263
1398	A264
1399	A265
1400	A266
1401	A267
1402	A268
1403	A269
1404	A270
1405	A271
1406	A272
1407	A273
1408	A274
1409	A275
1410	A276
1411	A277
1412	A278
1413	A279
1414	A280
1415	A281
1416	A282
1417	A283
1418	A284
1419	A285
1420	A286
1421	A287
1422	A288
1423	A289
1424	A290
1425	A291
1426	A292
1427	A293
1428	A294
1429	A295
1430	A296
1431	A297
1432	A298
1433	A299
1434	A300
1435	A301
1436	A302
1437	A303
1438	A304
1439	A305
1440	A306
1441	A307
1442	A308
1443	A309
1444	A310
1445	A311
1446	A312
1447	A313
1448	A314
1449	A315
1450	A316
1451	A317
1452	A318
1453	A319
1454	A320
1455	A321
1456	A322
1457	A323
1458	A324
1459	A325
1460	A326
1461	A327
1462	A328
1463	A329
1464	A330
1465	A331
1466	A332
1467	A333
1468	A334
1469	A335
1470	A336
1471	A337
1472	A338
1473	A339
1474	A340
1475	A341
1476	A342
1477	A343
1478	A344
1479	A345
1480	A346
1481	A347
1482	A348
1483	A349
1484	A350
1485	A351
1486	A352
1487	A353
1488	A354
1489	A355
1490	A356
1491	A357
1492	A358
1493	A359
1494	A360
1495	A361
1496	A362
1497	A363
1498	A364
1499	A365
1500	A366

DECODER-2

- ATSB - Attenuation of Audio Level in Search Position
- ATT - Attenuation
- CL - Clock Signal
- CLAB - Clock Signal Decoder-A to Filter-B
- CLBD - Clock Signal Filter-B to DAC
- DA - Data Signal
- DAAB - Data Signal Decoder-A to Filter-B
- DABD - Data Signal Filter-B to DAC
- DEC - Deemphasis Control
- DOBM - Digital Out Signal
- EFAB - Error Flag Decoder-A to Filter-B
- MUSB - Soft Mute Signal
- SCAB - Subcode Clock Decoder-A to Filter-B
- SDAB - Subcode Data Decoder-A to Filter-B
- WS - Word Select
- WSAB - Word Select Decoder-A to Filter-B
- WSBD - Word Select Filter-B to DAC
- X-IN - Oscillator Signal in Decoder-A
- X-OUT - Oscillator Signal out Decoder-A
- XSYS - Oscillator Signal

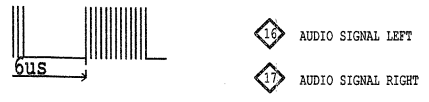

BS DAC PANEL

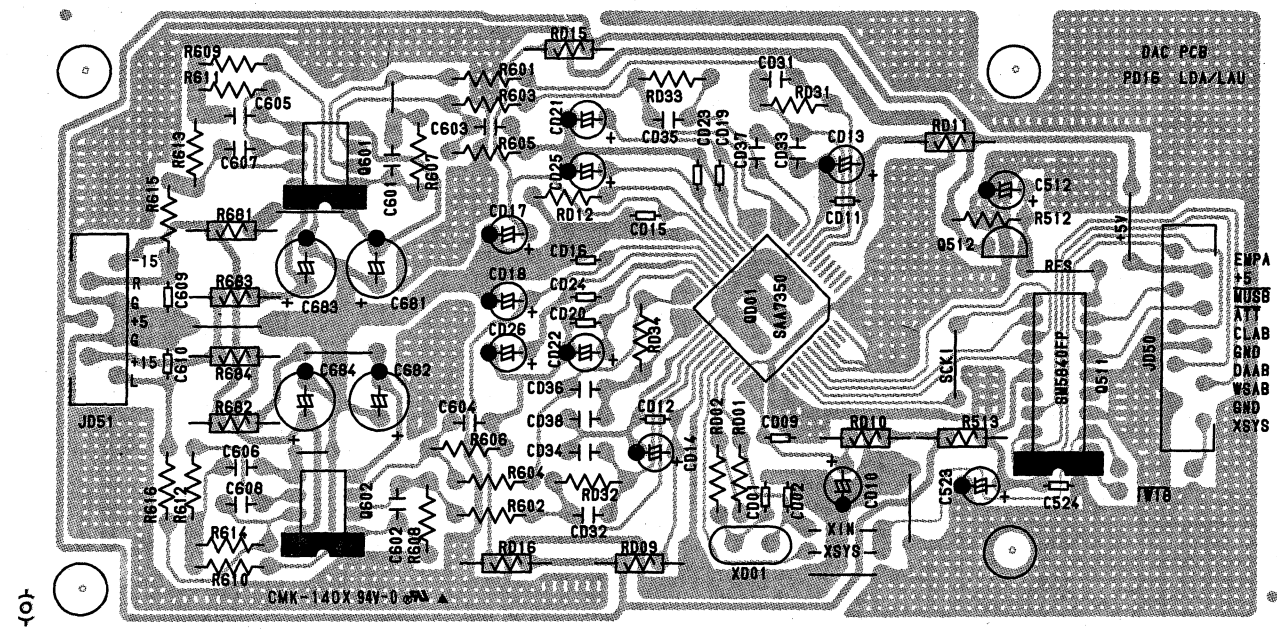

1800 C2	1815 A7	1826 A9	1835 A9	1845 A10	3803 D4	3816 D10	6800 D4	6810 A6	7802 B5	9005 D9	9015 C2	9025 A5	9035 C2
1801 D2	1816 A8	1827 A12	1836 A11	1846 B7	3804 D4	3817 B8	6801 D3	6811 A6	7803 B3	9006 D9	9016 C2	9026 A6	9036 C3
1802 D12	1817 A10	1828 B12	1837 B12	2802 C2	3805 D4	3818 C2	6802 D2	6812 A5	7804 B2	9007 D7	9017 C2	9027 A5	9045 D2
1804 E6	1818 A11	1829 A13	1838 A14	2803 C3	3806 B6	3819 C2	6803 D3	6813 A5	7805 D10	9008 D11	9018 B4	9028 B5	
1805 C1	1819 B11	1830 A4	1839 C3	2804 D3	3807 C5	3820 D6	6804 D3	6814 C3	7806 D8	9009 D3	9019 B5	9029 A7	
1810 B10	1820 A13	1831 B4	1840 B3	2805 D2	3808 D3	3821 D10	6805 D5	6815 C3	9000 D10	9010 D3	9020 B5	9030 D11	
1811 A12	1821 C5	1832 A3	1841 A3	2806 D2	3809 D3	3822 D2	6806 D4	6816 B3	9001 E10	9011 C4	9021 B4	9031 D12	
1812 C6	1822 B5	1833 A6	1842 A5	3800 D7	3810 B3	3823 D2	6807 D3	6817 B3	9002 D10	9012 D2	9022 B4	9032 A6	
1813 B6	1823 A7	1834 A6	1843 B8	3801 D3	3811 B3	3824 D2	6808 D4	6818 B3	9003 C4	9013 C2	9023 A4	9033 B4	
1814 A4	1824 A8	1834 B9	1844 B9	3802 D4	3812 C3	3825 D2	6809 D4	7801 B6	9004 D8	9014 C2	9024 B3	9034 C2	

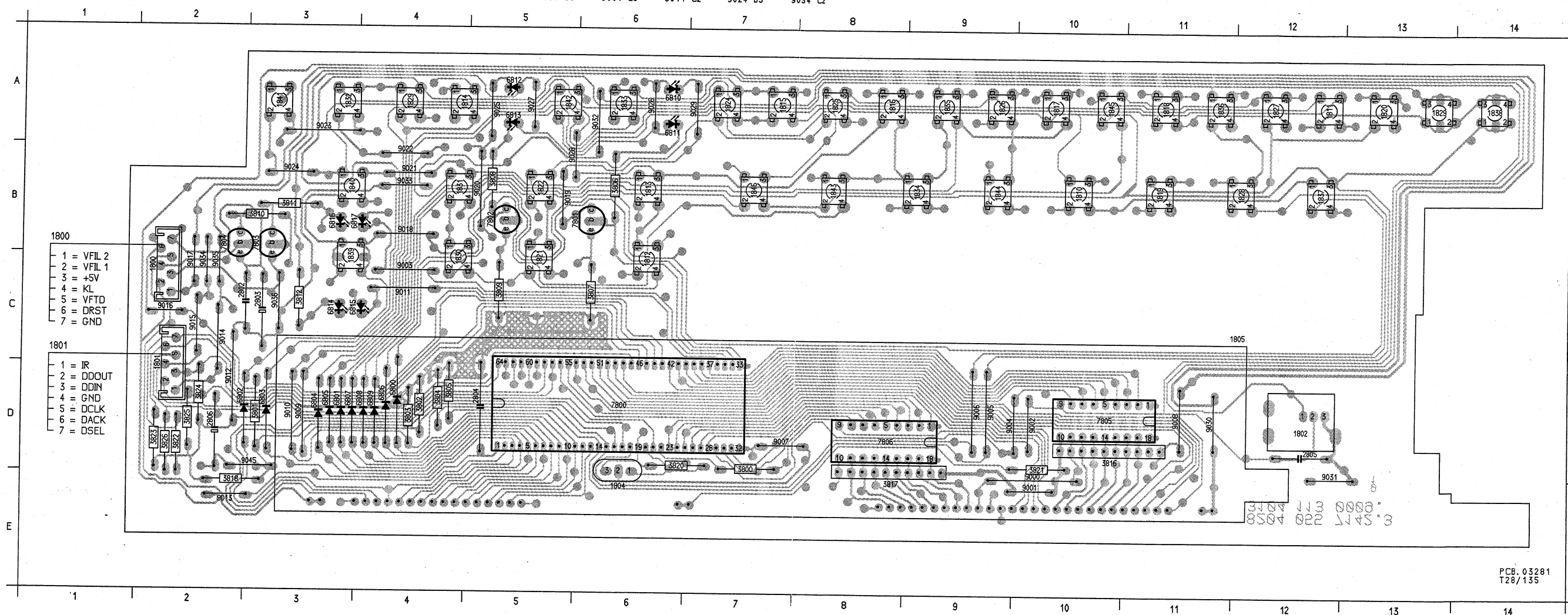

PCB 03281
T28/135

HEADPHONE CIRCUIT DIAGRAM

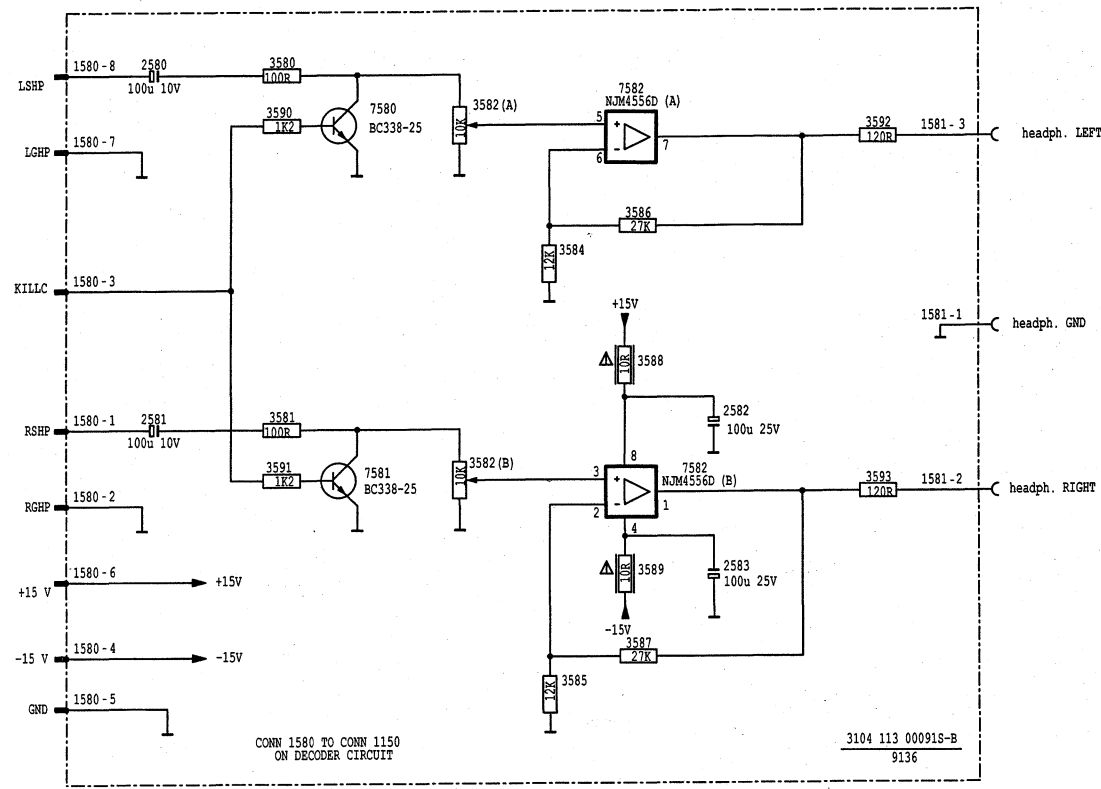

HEADPHONE PANEL

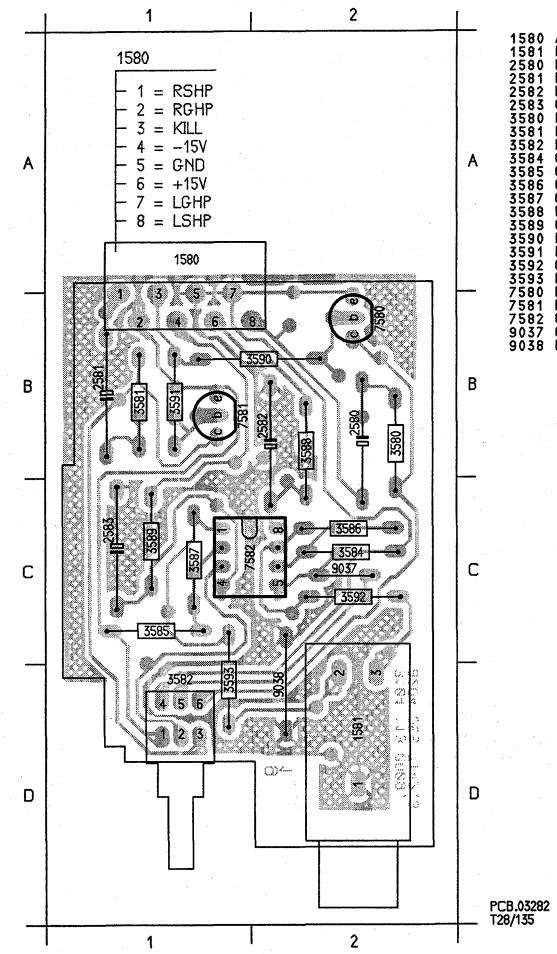

- 1580 A1
- 1581 D2
- 2580 B2
- 2581 B1
- 2582 B2
- 2583 C1
- 3580 B2
- 3581 B1
- 3582 D1
- 3584 C2
- 3585 C2
- 3586 C1
- 3587 C1
- 3588 B2
- 3589 C1
- 3590 B1
- 3591 B1
- 3592 C2
- 3593 D1
- 7580 B2
- 7581 B1
- 7582 C2
- 9037 C2
- 9038 D2

LEVEL AND BALANCE CIRCUIT DIAGRAM

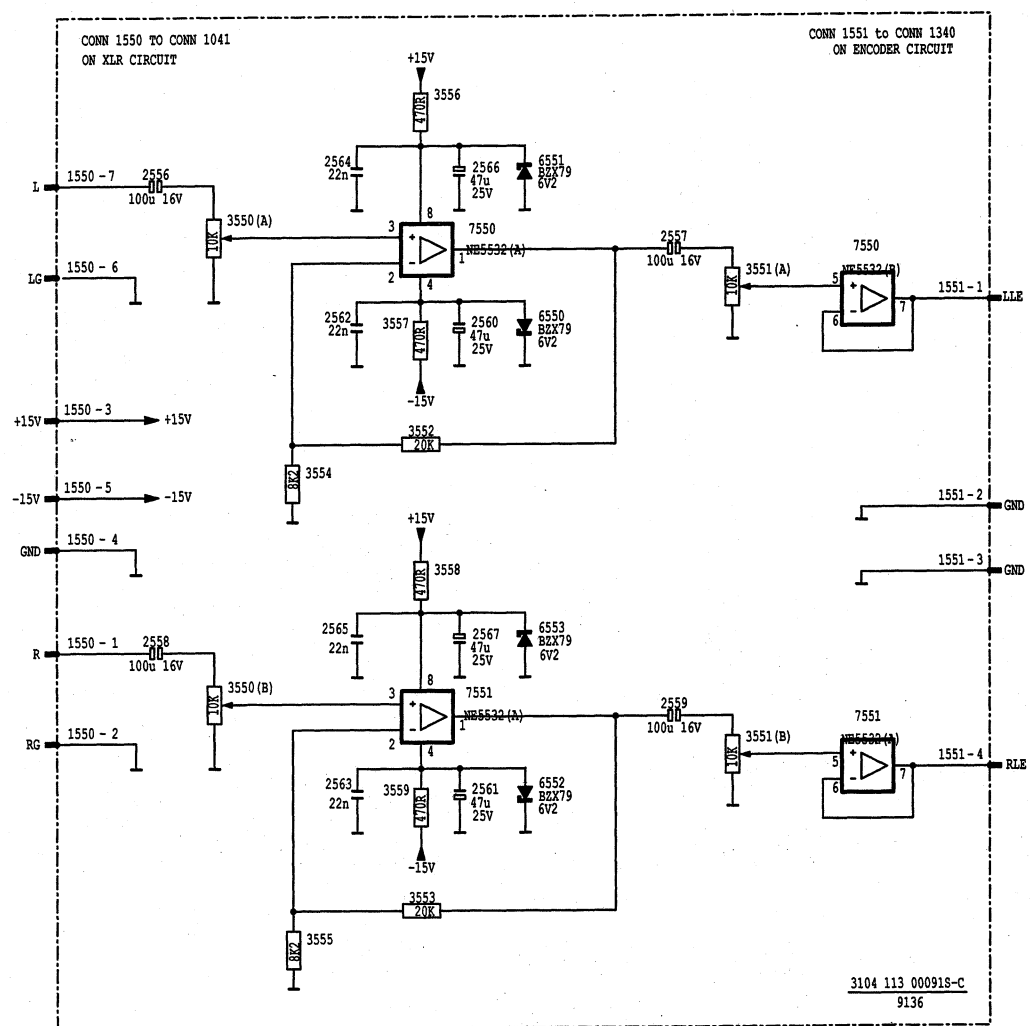

LEVEL AND BALANCE PANEL

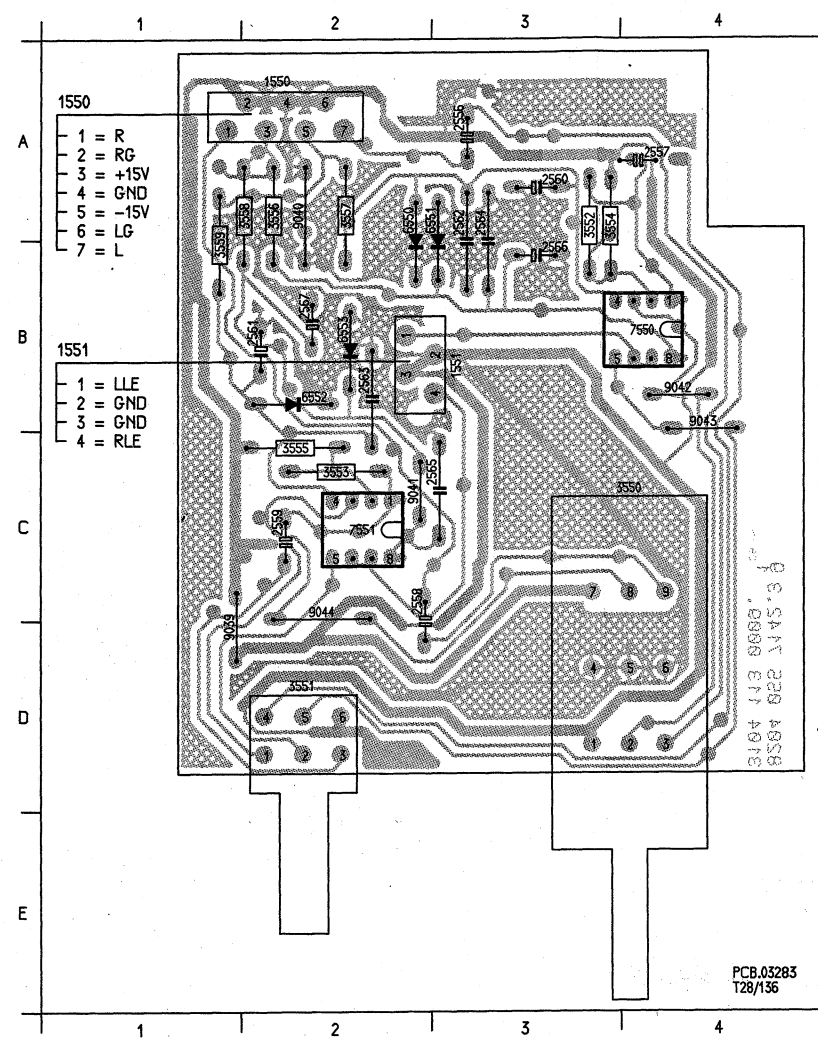

LEVEL D	
1501	A 1 27
1501	E 1 27
2750	D 7 27
2751	A 7 27
2752	F 7 27

LEVEL D	
1550	A2
1551	B3
2556	A3
2557	A4
2558	C2
2559	C3
2560	A3
2561	B2
2562	A4
2563	B2
2564	A3
2565	C3
2566	B3
2567	B2
3550	C3
3551	D2
3552	B3
3553	C2
3554	B3
3555	C2
3556	A2
3557	A2
3558	A2
3559	B1
6550	A2
6551	A3
6552	B2
6553	B2
7550	B4
7551	C2
9039	D1
9040	A2
9041	C2
9042	B4
9043	B4
9044	C2

LEVEL D	
ENCODER - 3	1
CONN. 11 ON D1	A
LDR - 1501	B
LDR - 1501	E
+15	F
-15	F

LEVEL AND BALANCE PANEL

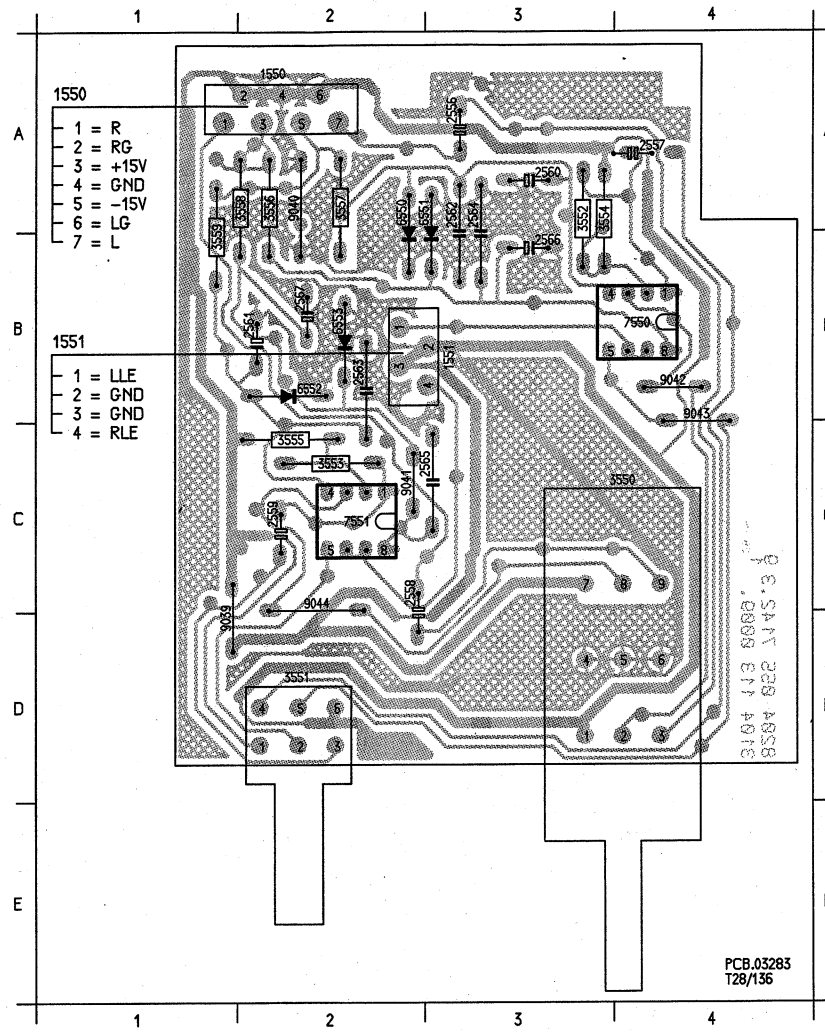

- 1550 A2
- 1551 B3
- 2556 A3
- 2557 A4
- 2558 C2
- 2559 C2
- 2560 A3
- 2561 B2
- 2562 A3
- 2563 B2
- 2564 A3
- 2565 C3
- 2566 B3
- 2567 B2
- 3550 C3
- 3551 D2
- 3552 B5
- 3553 C2
- 3554 B3
- 3555 C2
- 3556 A2
- 3557 A2
- 3558 A2
- 3559 B1
- 6550 A2
- 6551 A3
- 6552 B2
- 6553 B4
- 7550 B4
- 7551 C2
- 9039 D1
- 9040 A2
- 9041 C2
- 9042 B4
- 9043 B4
- 9044 C2

LEVEL DETECTION CIRCUIT DIAGRAM

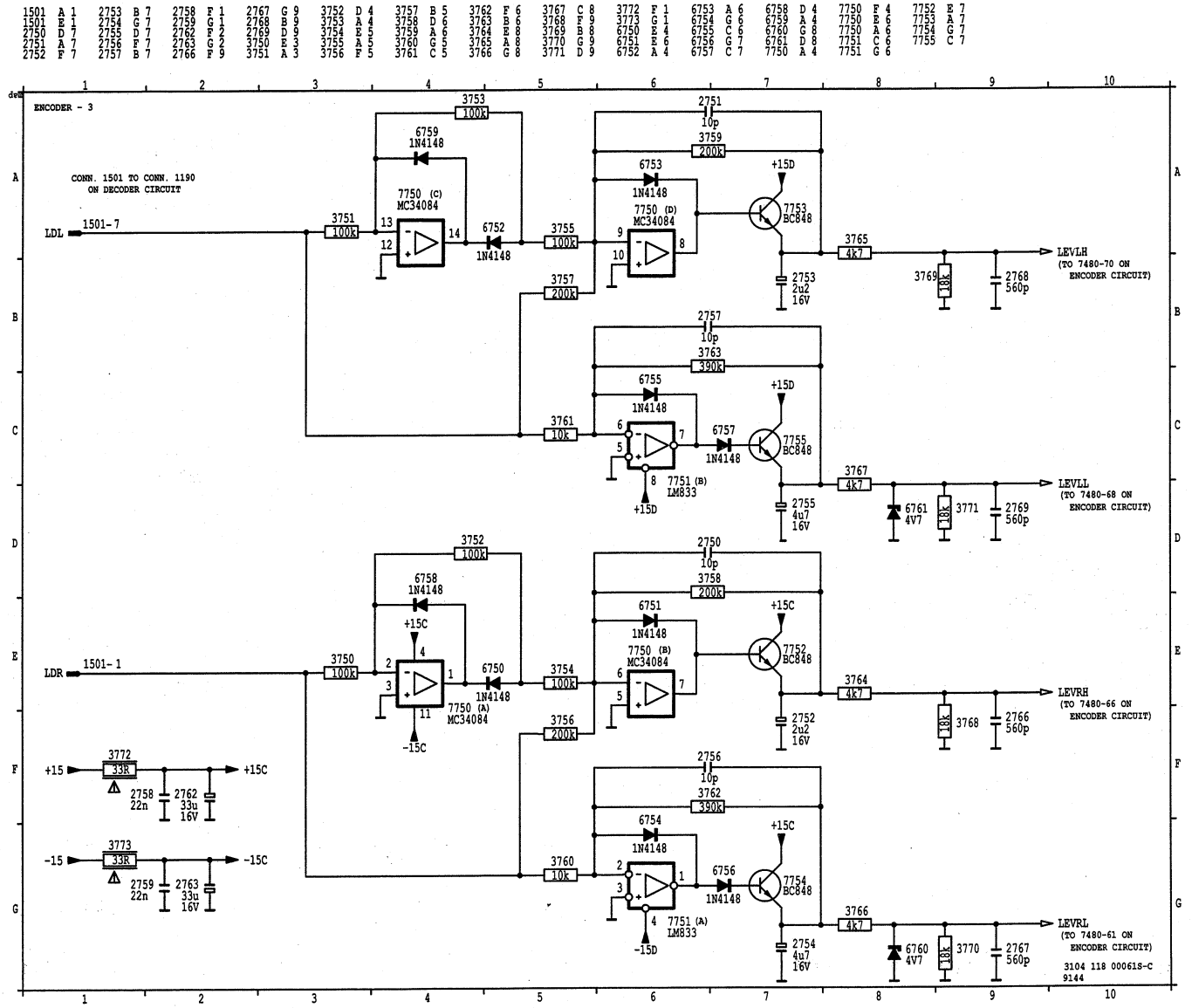

The components of this circuit diagram are situated on the ENCODER PANEL.

MDA.03057

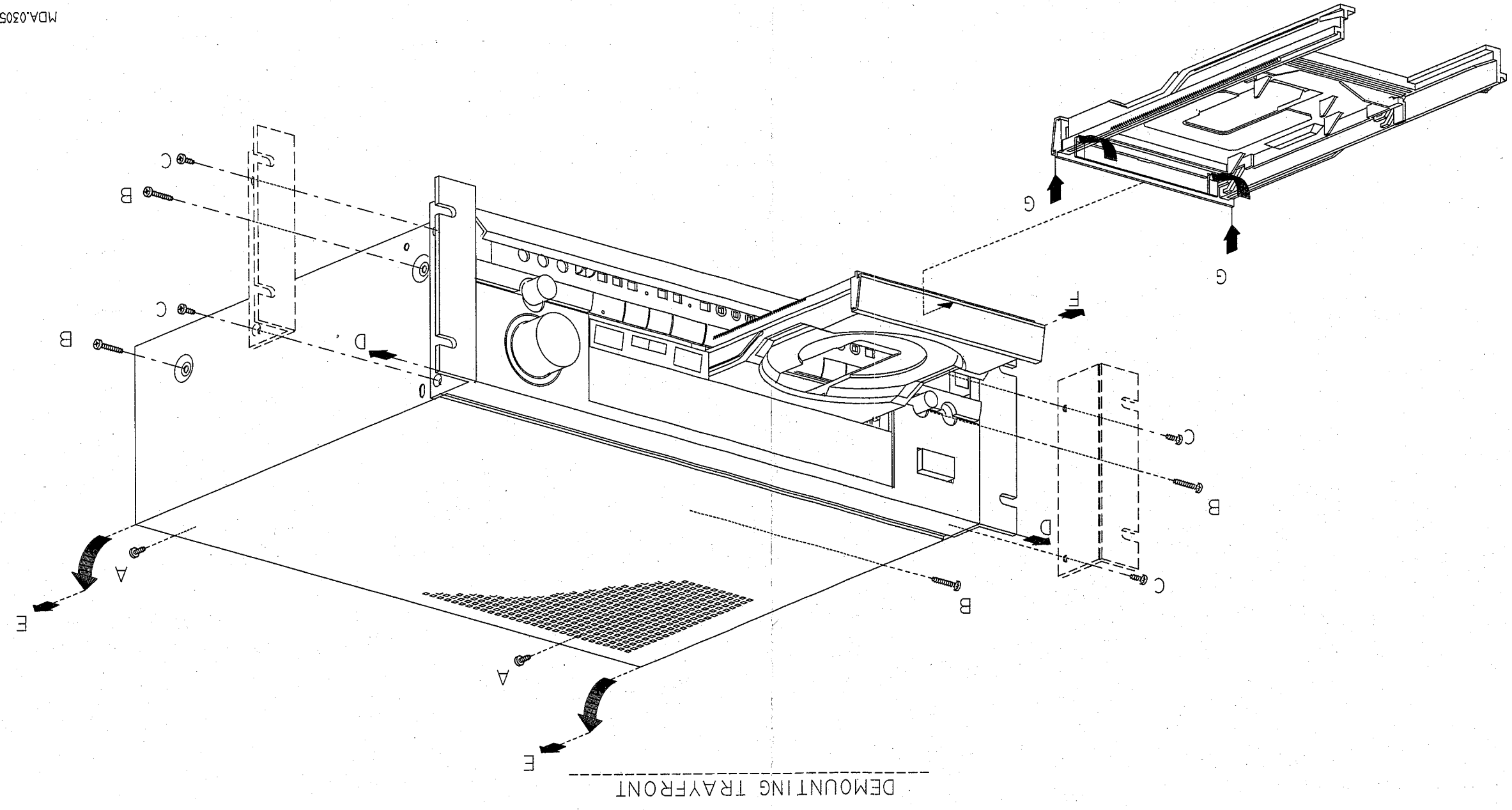

6

6

DEMOUNTING TRAYFRONT

DISASSEMBLY
TRAYFRONT

DEMOUNTING FRONT

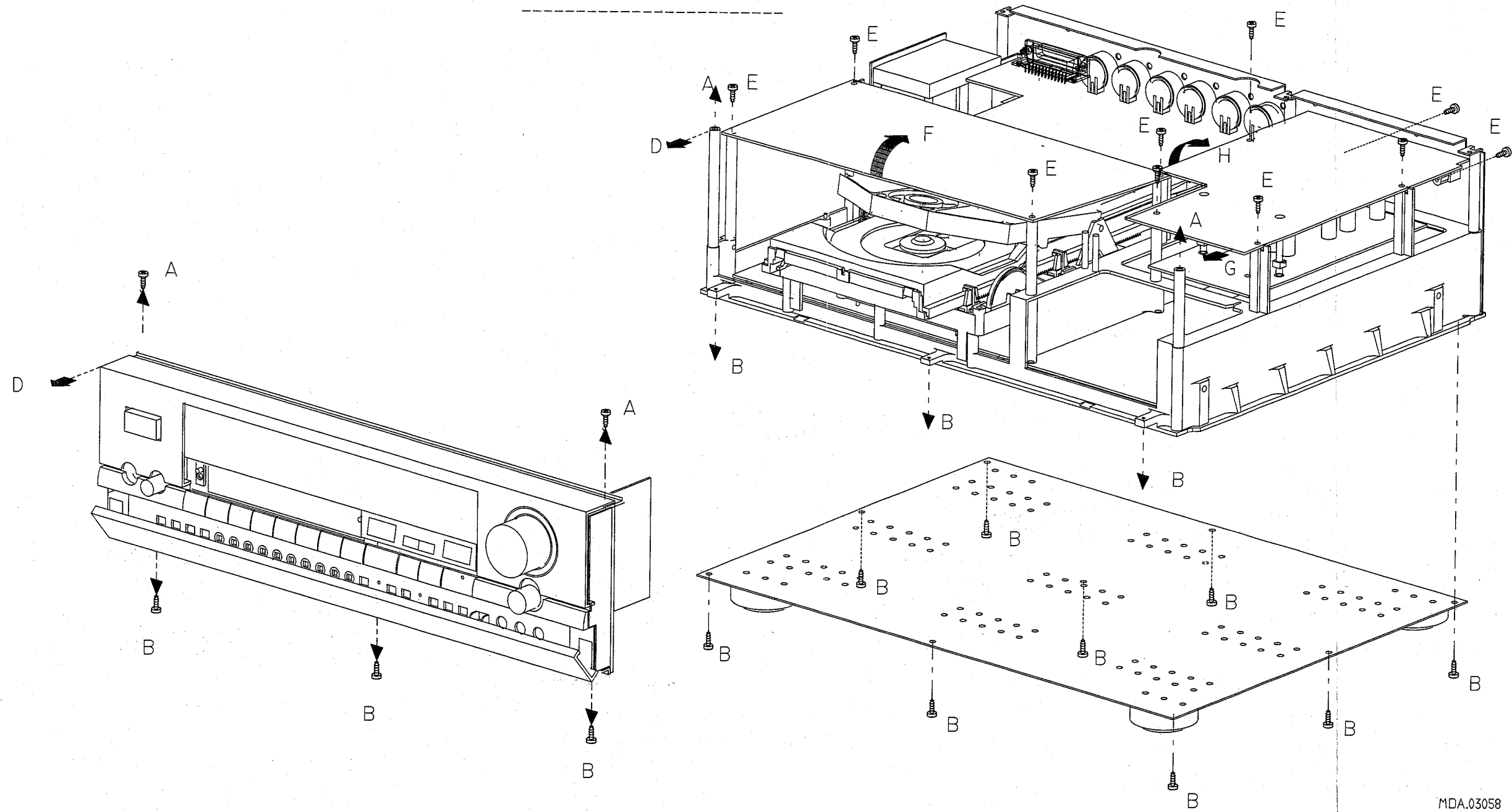

MDA.03058

DEMOUNTING TRAY-ASSY

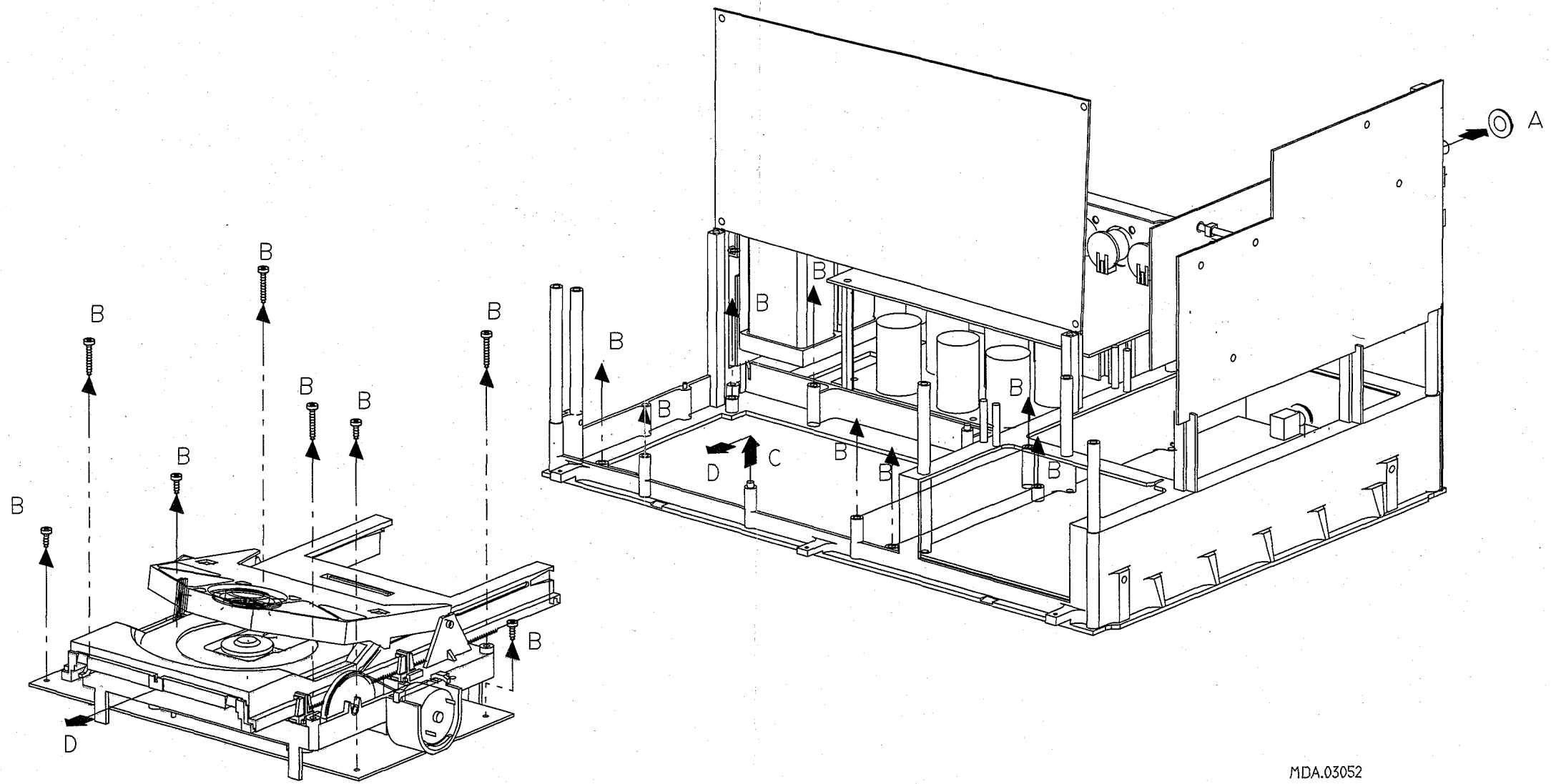

MDA.03052

DISASSEMBLY WOSP CDM

DEMOUNTING OF WOSP-PCB

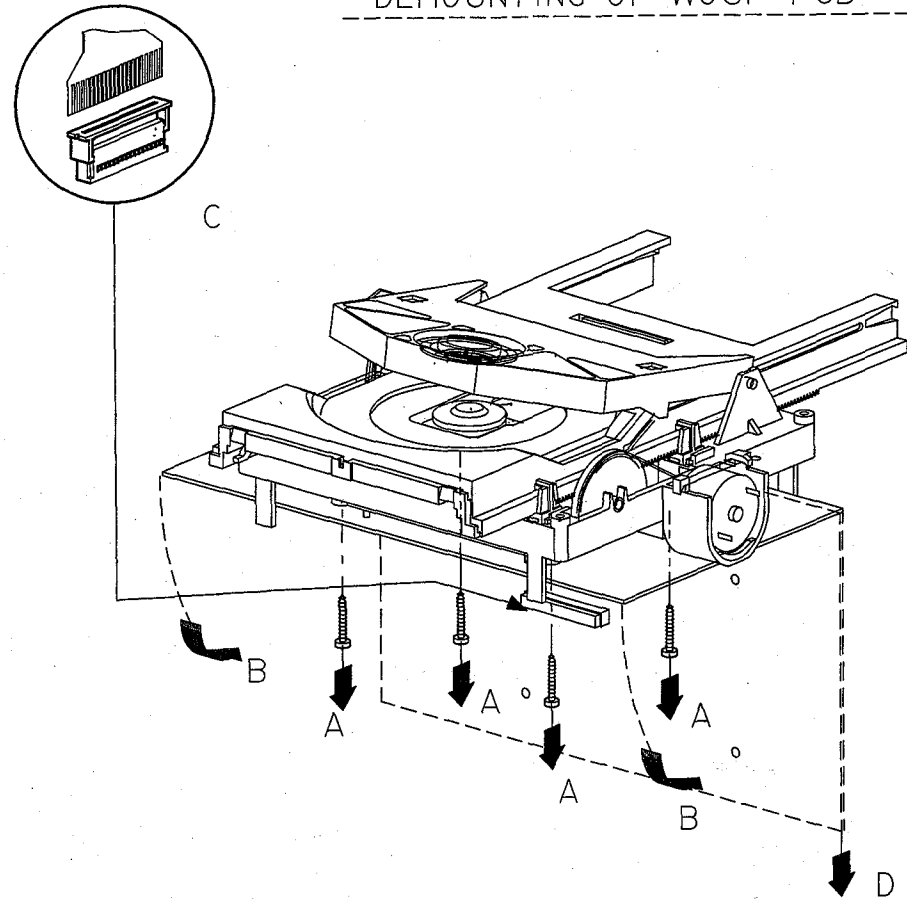

DEMOUNTING OF CDM

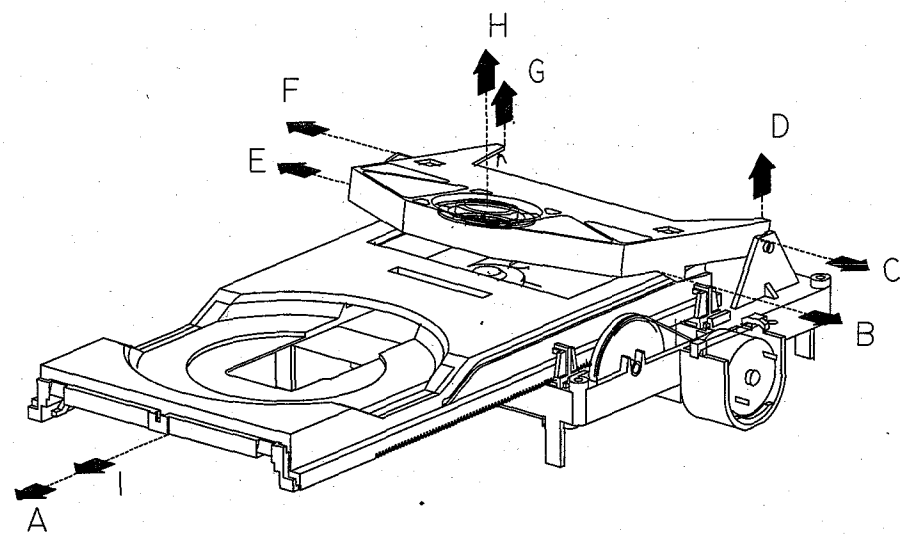

MDA.03054

SERVICE HINTS

In the set chip componens have been applied.
For disassembly and assembly of chip components see the figure below.

GENERAL

SCALE 1 : 1

DISMOUNTING

VACUUM PISTON 4822 395 10082
SOLDERING IRON e.g. WELLER SOLDER TIP PT-H7

OR

SOLDERING IRON 4822 321 40042

e.g. A PAIR OF TWEEZERS

HEATING HEATING

SOLDERING IRON
SOLDER WICK CLEANING

MOUNTING

e.g. A PAIR OF TWEEZERS

SOLDER Ø 0.5 - 0.8 mm
SOLDERING IRON PRESSURE

SOLDERING TIME < 3 sec./side
SOLDER Ø 0.5 - 0.8 mm
PRESSURE SOLDERING IRON

EXAMPLES

RIGHT

PRECAUTIONS

SOLDERING IRON RIGHT

COPPER TRACK

SOLDERING IRON CHIP COMPONENT

SERVICE PACKAGE

NO!

Components have been applied.
and assembly of chip components see

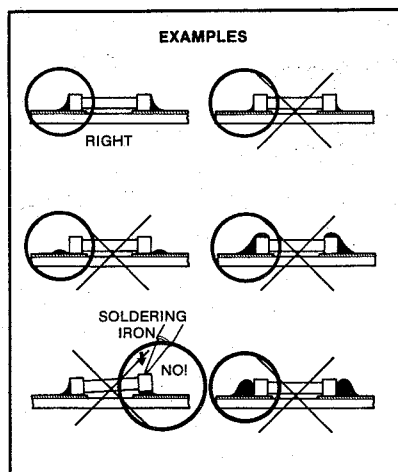
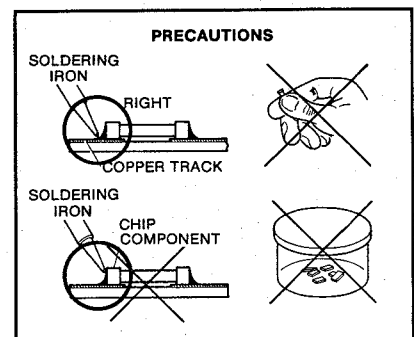
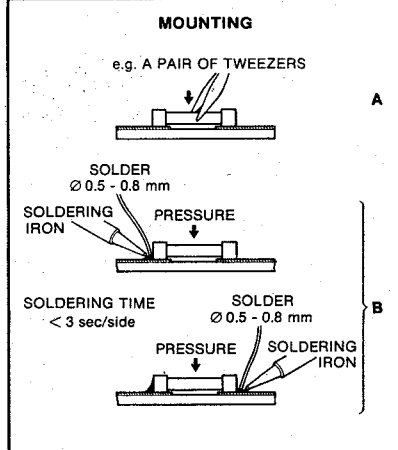
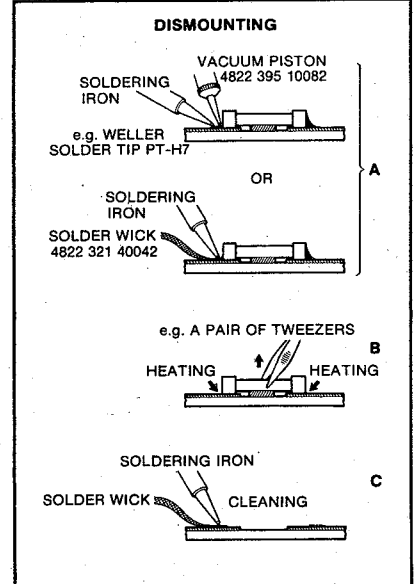
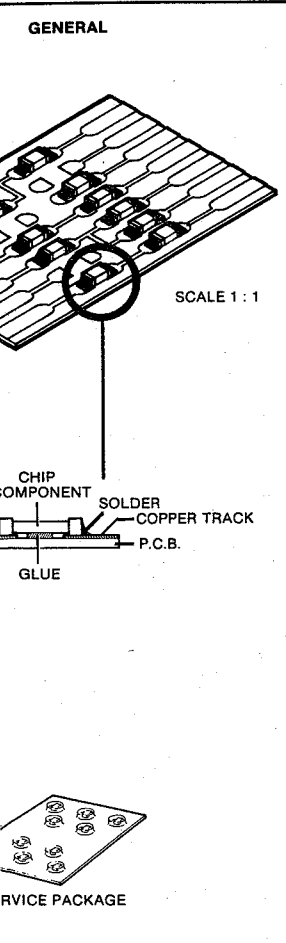

A0-10 - RAM Addressbus Bit 0 - 10
 AINL - Left Channel Analog Input
 AINR - Right Channel Analog Input
 AINT - Absorption Integrator
 ALFA - Actual Absorption
 ALFA0 - Absorption Set
 ALFALS - Absorption Loop Switch
 AM - Additional Mute
 APD - Analog Power Down
 ATT - Attenuation
 CA - Central Apperture Signal
 CAN - Central Apperture Signal Normalized
 CE - Chip Enable
 CECS - CIRC EFM Chip Select
 CEFS - CIRC EFM Frame Sync
 CEPB - CIRC EFM Pause Bit
 CERES - CIRC EFM Reset
 CERS - CIRC EFM Register Select
 CESSY - CIRC EFM Subcode Sync
 CL - Clock
 CLAB - Clock Signal Decoder-A to Filter-B
 CLK - System Clock Input
 CRI - Counter Reset Inhibit
 CS - Chip Select
 D0 - 7 - Data Bus Bit 0 - 7
 DA - Data
 DAAB - Data Signal Decoder-A to Filter-B
 DACK - Display Acknowledge
 DDIN - Display Data Input
 DDOUT - Display Data Output
 DEC - Deemphasis Control
 DEEM - Deemphasis
 DIIRQ - Digital Input Interrupt Request
 DO - Drop Out
 DOBM - Digital Out Signal
 DPD - Digital Power Down
 DSEL - Display Select
 DSSY - Decoder Subcode Sync
 EFAB - Error Flag Decoder-A to Filter-B
 EFM - EFM Serial Data
 EFMCLK - Eight to Fourteen Modulation
 EFMDD - Eight to Fourteen Modulation Detect
 FEN - Focus Error Normalized
 FOCOK - In Focus Signal
 FOCON - Focus On
 FSA - Forward Sense Diode Anode
 FSC - Forward Sense Diode Cathode
 FSO - Laser Power Set
 GND - Ground
 HF - High Frequency
 HFI - High Frequency Input
 IA - 3 Spot Push Pull Diode Current
 IB1-2 - 3 Spot Push Pull Diode Current
 IC1-4 - 3 Spot Push Pull Diode Current
 IHF - CA Current To Remainder Part Of CA Processor
 INSEL - Input Selector
 IR - Infrared Receiver Signal
 IWREF - Laser Writing Power Reference
 L - Left
 L/R - Left/Right Select
 LASWR - Laser Write/Non Read
 LEVLH - Analog Level Left High
 LEVLL - Analog Level Left Low
 LEVRH - Analog Level Right High
 LEVRL - Analog Level Right Low
 LSRON - Laser On
 LTCLK - Interface Data Bit Clock
 LTCNT0-1 - Interface Control
 LTDAT - Interface Databus
 LTEN - Interface Enable
 MC - Motor Control Signal
 MCK - Master Clock
 MCKN - Master Clock NOT
 MCSEL - Motor Control Select
 MERR - Motor Control Error Signal

MREADY - Turntable Motor Ready
 MSC - External Motor Control Input
 MSTCK - Master Clock
 MUSB - Soft Mute Signal
 MUTE - Mute Signal
 NFR - Output Level Converter RX1
 POWOK - Laser Power OK
 PPN - Normalized Push Pull Signal
 QCL - Q-Channel Clock Signal
 QDA - Q-Channel Data Signal
 QRA - Q-channel Request Acknowledge
 R - Right
 RADJ - Radial Gain Adjust
 RBI - Radial Brake Inhibit
 RD - μ P Read Signal
 RD0 - 7 - RAM Databus Bit 0 - 7
 REGAIN - Radial Gain Current
 REN - Radial Error Normalized
 RGH - Radial Gain High
 RIRES - Radial Integrator Reset
 Riset - Radial Integrator Preset
 RJEN - Radial Jump Enable
 RJGAIN - Radial Jump Gain
 RJV1-7 - Radial Jump Voltage
 RLS - Radial Loop Switch
 RP - Radial Polarity
 RPDIV - Radial Polarity Divider
 RPS - Radial Polarity Select
 RST - Hard Reset
 RTL - Radial Track Loss
 RX1 - IEC Format Digital Audio Data Input (Coaxial Input)
 RX2 - IEC Format Digital Audio Data Input (Optical Input)
 RXD - Serial Data
 RXSEL - Selection RX1 Or RX2
 SACK - Servo Acknowledge
 SCAB - Subcode Clock Decoder-A to Filter-B
 SCK - Serial Clock (IS)
 SCK/BCK - Shift/Bit Clock Audio Data
 SCLK - Serial Output Data Clock
 SD0 - 1 - Serial Data (IS)
 SDAB - Subcode Data Decoder-A to Filter-B
 SDAT - Servo Data
 SDATA - Serial Data Output
 SDO - Serial Data Output Audio Databus
 SETSY - Setting Sync Signal
 SLBS - Slide Begin Switch
 SLIN - Slide Inwards Pulse
 SLLS - Slide Servo Loopswitch
 SLOR/RKDAC - Slide Outwards Request/ADC Determination Radial Amplitude
 SLOUT - Slide Outwards Pulse
 SRCMC - Shift Register Clock Motor Control
 SRCRG - Shift Register Clock Radial Gain
 SRDAT - Shift Register Data
 SREQ - Servo Request
 SRST - Servo Reset
 SSEL - Source Select
 SWAB/SSM - Subcode Word/Start-Stop Motor Signal
 TLN - Trackloss Normalized
 TRIN - Tray In Switch
 TRMOT - Tray Motor Control
 TROUT - Tray Out Switch
 TX - IEC Format Digital Data Output
 TXD - Serial Clock
 TXOE - Reset
 UCH - Subcode U Channel
 UNLOCK - Indication VCO Frequency
 USYNC01 - Indication Start New Frame
 WPCS - Wobble Processor Chip Select
 WR - μ P Write Signal
 WRLASER - Write Mode/Non Read Mode Laser
 WS - Word Select Signal
 WS/LRCK - Word Select Audio Data
 WSAB - Word Select Decoder-A to Filter-B
 WSBD - Word Select Filter-B to DAC
 XSYS - Oscillator Signal

WIRING DIAGRAM

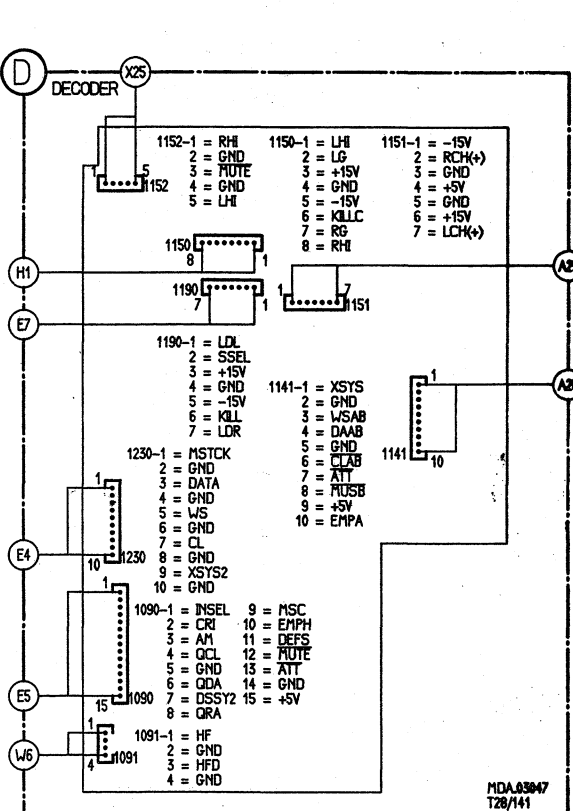
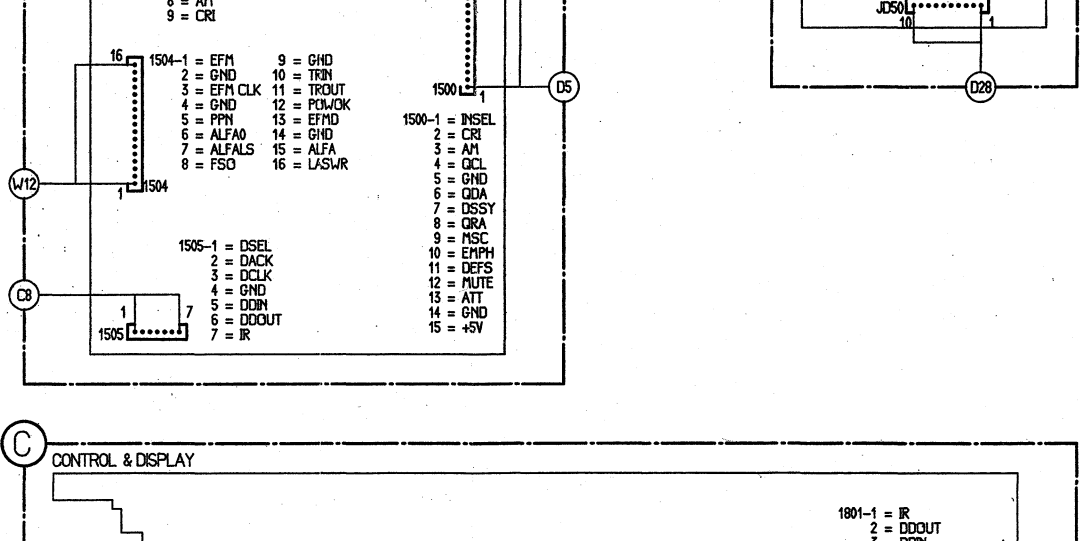
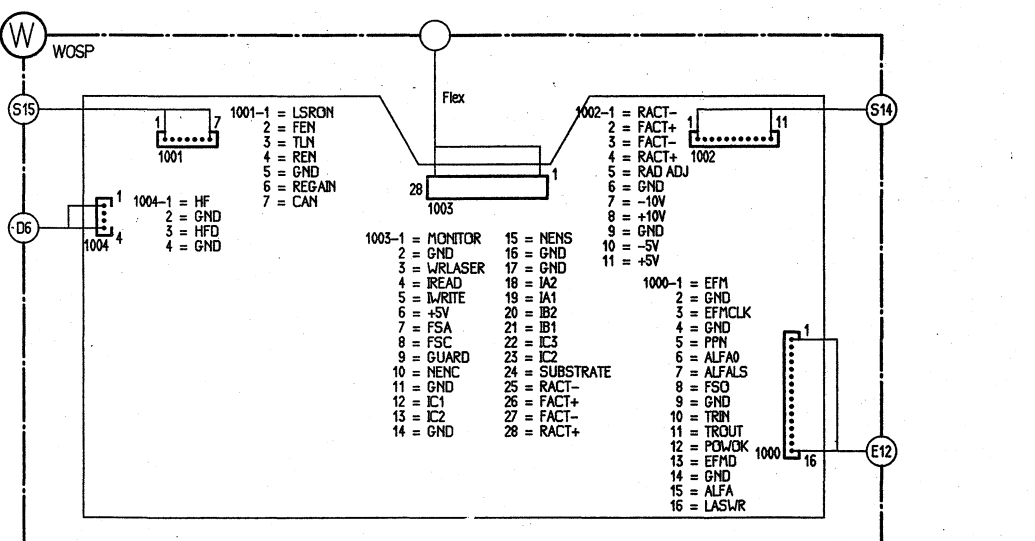
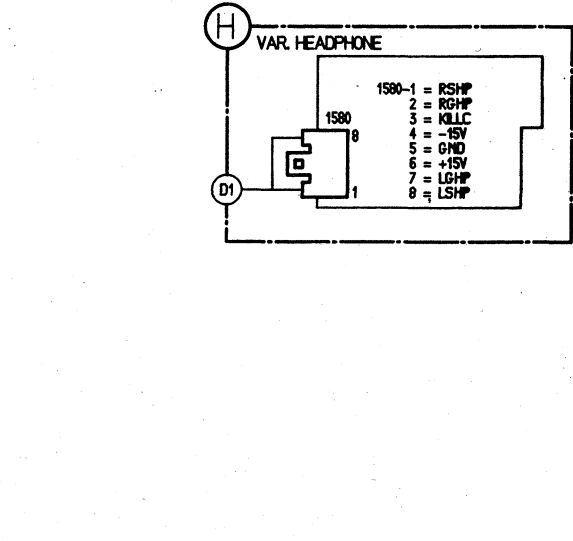
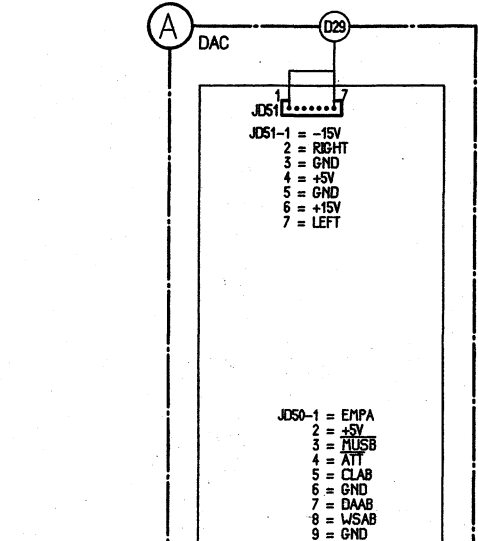
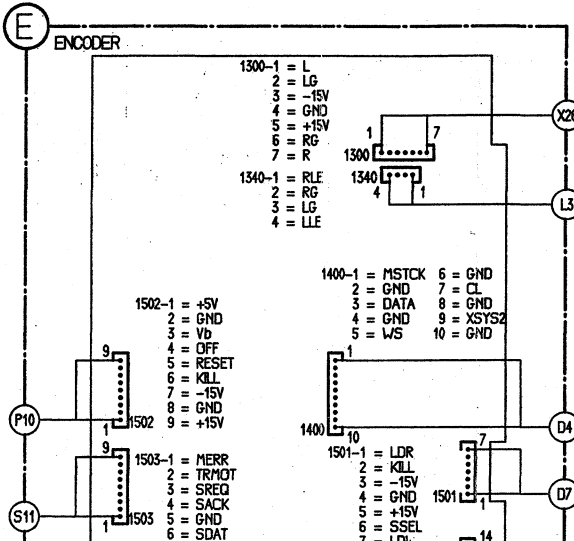
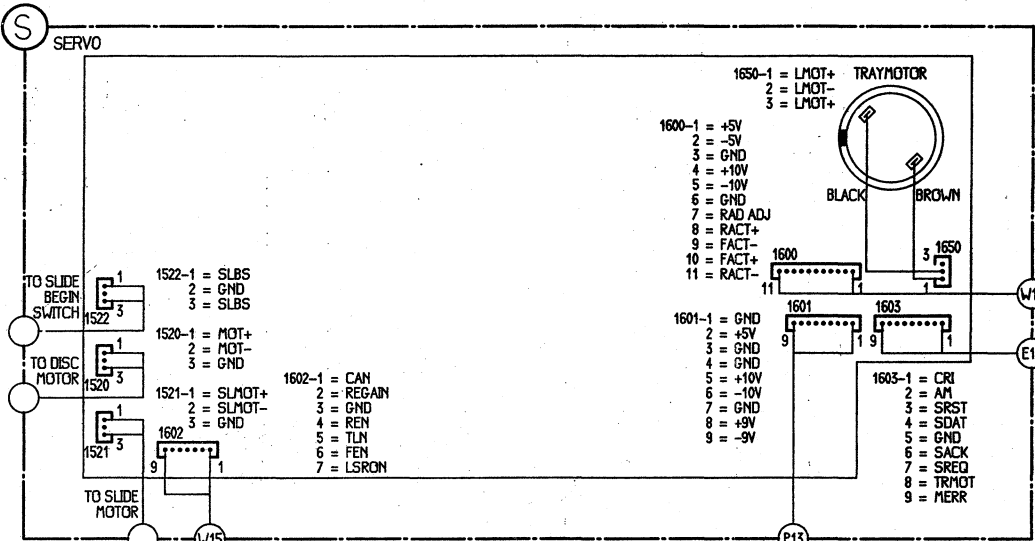
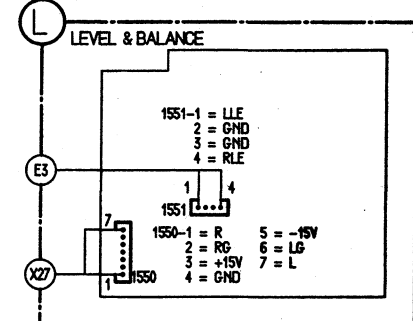
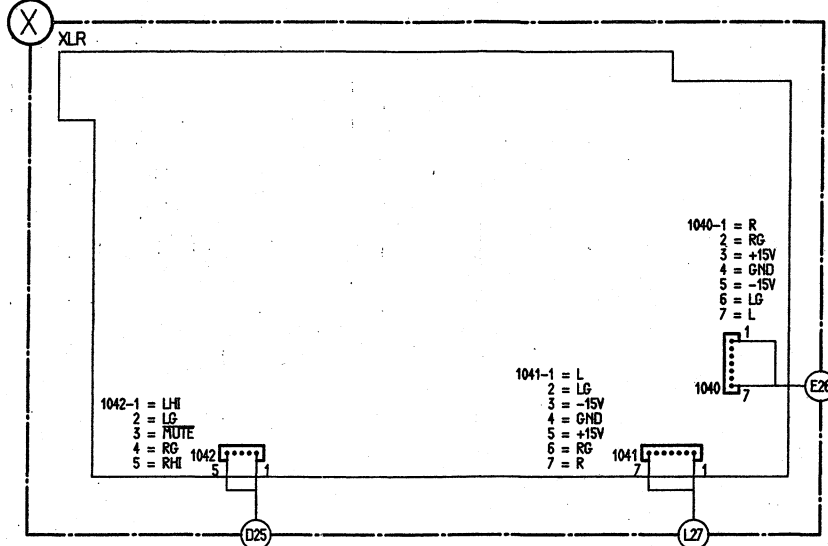
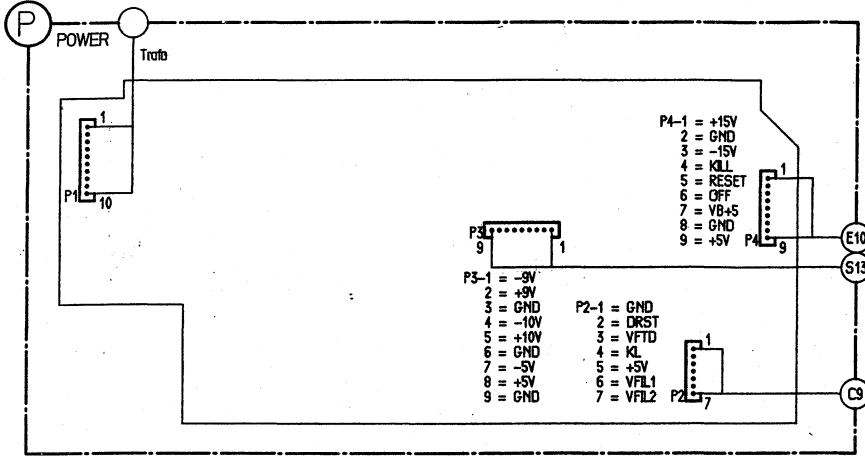

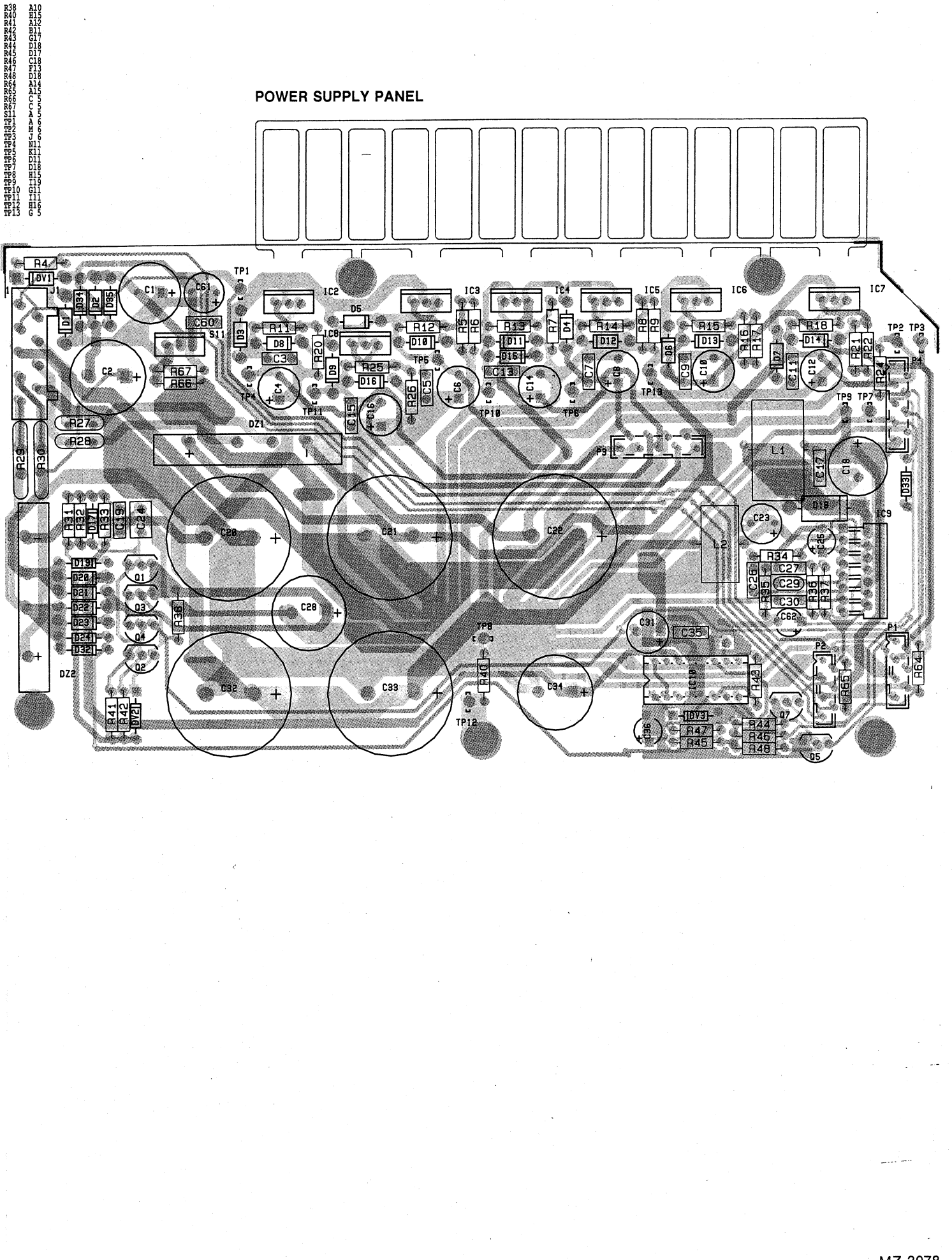
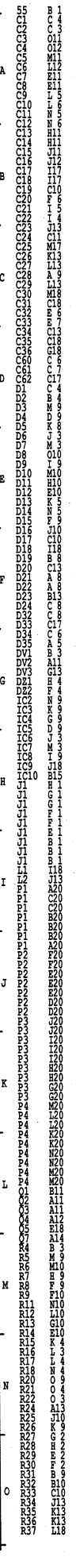
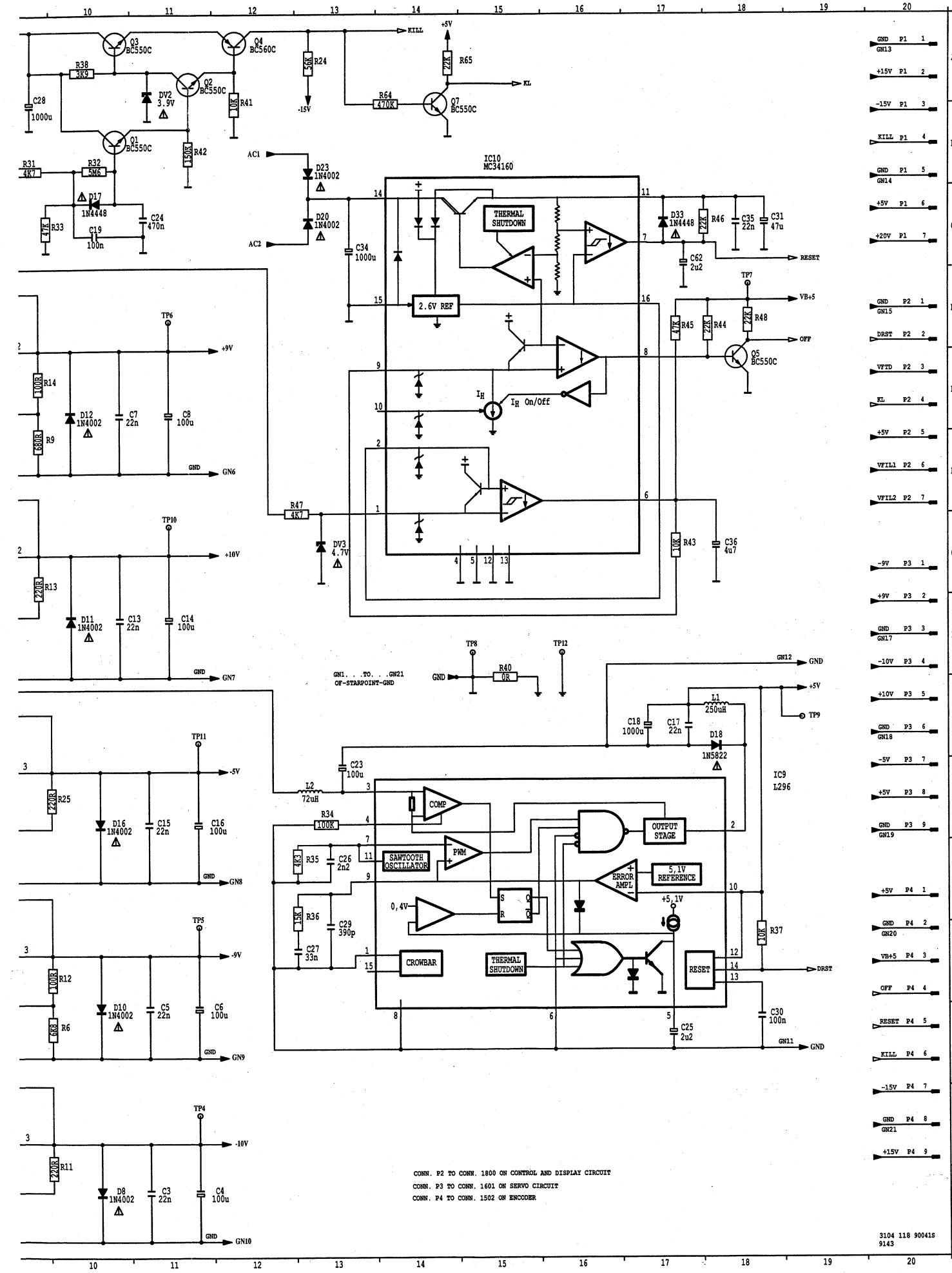

MOTOR ON/OFF DETECTION

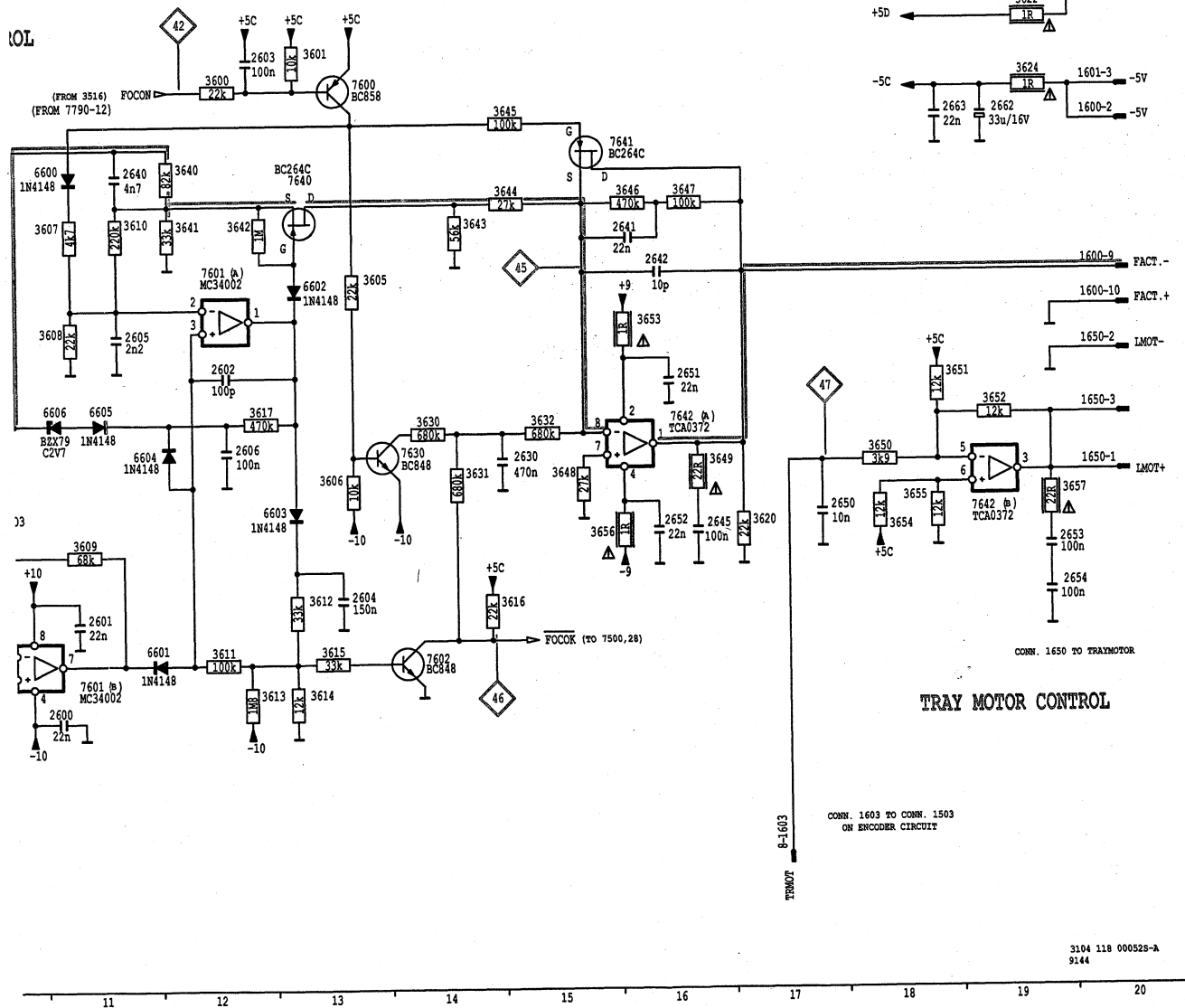
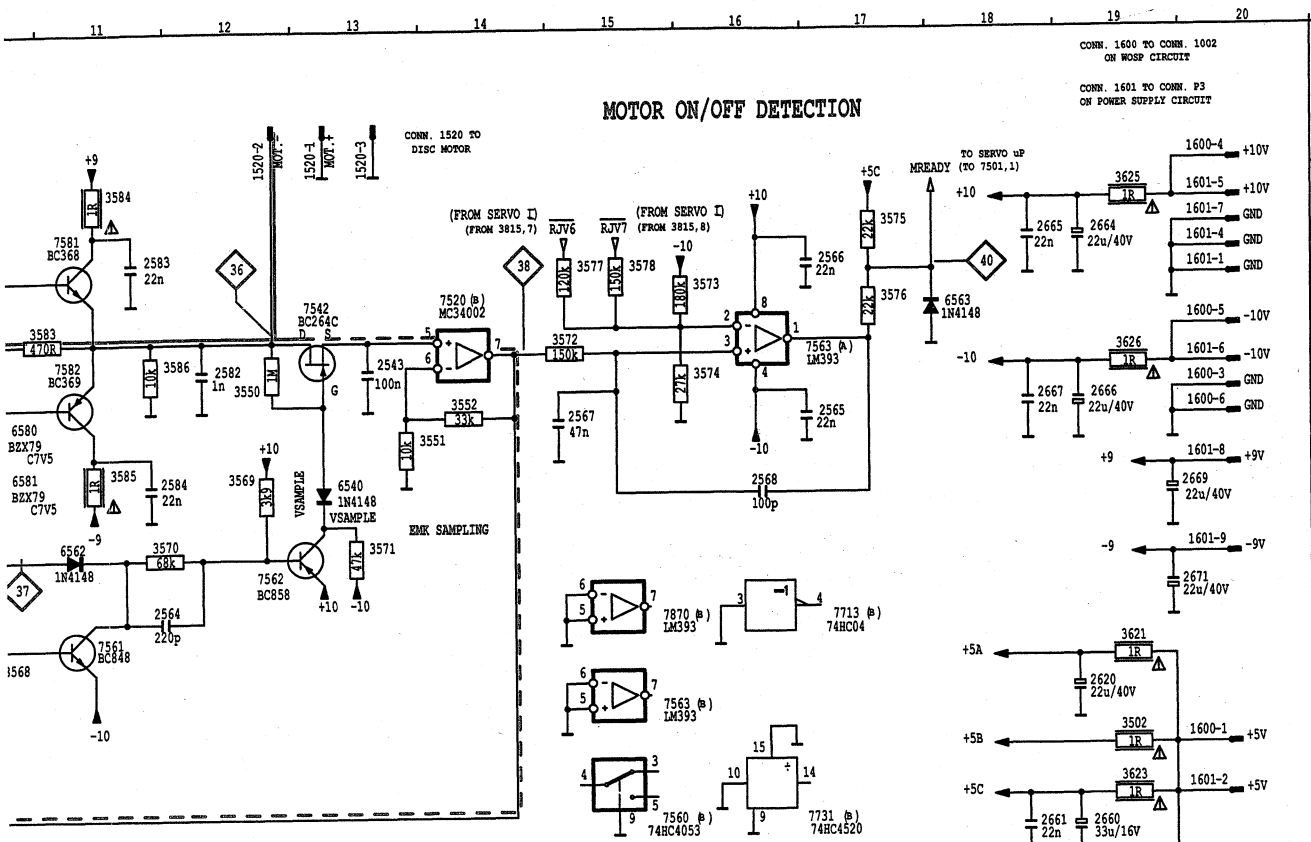

1520 B12
1521 B13
1522 B14
1523 B15
1524 B16
1525 B17
1526 B18
1527 B19
1528 B20
1529 B21
1530 B22
1531 B23
1532 B24
1533 B25
1534 B26
1535 B27
1536 B28
1537 B29
1538 B30
1539 B31
1540 B32
1541 B33
1542 B34
1543 B35
1544 B36
1545 B37
1546 B38
1547 B39
1548 B40
1549 B41
1550 B42
1551 B43
1552 B44
1553 B45
1554 B46
1555 B47
1556 B48
1557 B49
1558 B50
1559 B51
1560 B52
1561 B53
1562 B54
1563 B55
1564 B56
1565 B57
1566 B58
1567 B59
1568 B60
1569 B61
1570 B62
1571 B63
1572 B64
1573 B65
1574 B66
1575 B67
1576 B68
1577 B69
1578 B70
1579 B71
1580 B72
1581 B73
1582 B74
1583 B75
1584 B76
1585 B77
1586 B78
1587 B79
1588 B80
1589 B81
1590 B82
1591 B83
1592 B84
1593 B85
1594 B86
1595 B87
1596 B88
1597 B89
1598 B90
1599 B91
1600 B92
1601 B93
1602 B94
1603 B95
1604 B96
1605 B97
1606 B98
1607 B99
1608 B100
1609 B101
1610 B102
1611 B103
1612 B104
1613 B105
1614 B106
1615 B107
1616 B108
1617 B109
1618 B110
1619 B111
1620 B112
1621 B113
1622 B114
1623 B115
1624 B116
1625 B117
1626 B118
1627 B119
1628 B120
1629 B121
1630 B122
1631 B123
1632 B124
1633 B125
1634 B126
1635 B127
1636 B128
1637 B129
1638 B130
1639 B131
1640 B132
1641 B133
1642 B134
1643 B135
1644 B136
1645 B137
1646 B138
1647 B139
1648 B140
1649 B141
1650 B142
1651 B143
1652 B144
1653 B145
1654 B146
1655 B147
1656 B148
1657 B149
1658 B150
1659 B151
1660 B152
1661 B153
1662 B154
1663 B155
1664 B156
1665 B157
1666 B158
1667 B159
1668 B160
1669 B161
1670 B162
1671 B163
1672 B164
1673 B165
1674 B166
1675 B167
1676 B168
1677 B169
1678 B170
1679 B171
1680 B172
1681 B173
1682 B174
1683 B175
1684 B176
1685 B177
1686 B178
1687 B179
1688 B180
1689 B181
1690 B182
1691 B183
1692 B184
1693 B185
1694 B186
1695 B187
1696 B188
1697 B189
1698 B190
1699 B191
1700 B192
1701 B193
1702 B194
1703 B195
1704 B196
1705 B197
1706 B198
1707 B199
1708 B200
1709 B201
1710 B202
1711 B203
1712 B204
1713 B205
1714 B206
1715 B207
1716 B208
1717 B209
1718 B210
1719 B211
1720 B212
1721 B213
1722 B214
1723 B215
1724 B216
1725 B217
1726 B218
1727 B219
1728 B220
1729 B221
1730 B222
1731 B223
1732 B224
1733 B225
1734 B226
1735 B227
1736 B228
1737 B229
1738 B230
1739 B231
1740 B232
1741 B233
1742 B234
1743 B235
1744 B236
1745 B237
1746 B238
1747 B239
1748 B240
1749 B241
1750 B242
1751 B243
1752 B244
1753 B245
1754 B246
1755 B247
1756 B248
1757 B249
1758 B250
1759 B251
1760 B252
1761 B253
1762 B254
1763 B255
1764 B256
1765 B257
1766 B258
1767 B259
1768 B260
1769 B261
1770 B262
1771 B263
1772 B264
1773 B265
1774 B266
1775 B267
1776 B268
1777 B269
1778 B270
1779 B271
1780 B272
1781 B273
1782 B274
1783 B275
1784 B276
1785 B277
1786 B278
1787 B279
1788 B280
1789 B281
1790 B282
1791 B283
1792 B284
1793 B285
1794 B286
1795 B287
1796 B288
1797 B289
1798 B290
1799 B291
1800 B292
1801 B293
1802 B294
1803 B295
1804 B296
1805 B297
1806 B298
1807 B299
1808 B300
1809 B301
1810 B302
1811 B303
1812 B304
1813 B305
1814 B306
1815 B307
1816 B308
1817 B309
1818 B310
1819 B311
1820 B312
1821 B313
1822 B314
1823 B315
1824 B316
1825 B317
1826 B318
1827 B319
1828 B320
1829 B321
1830 B322
1831 B323
1832 B324
1833 B325
1834 B326
1835 B327
1836 B328
1837 B329
1838 B330
1839 B331
1840 B332
1841 B333
1842 B334
1843 B335
1844 B336
1845 B337
1846 B338
1847 B339
1848 B340
1849 B341
1850 B342
1851 B343
1852 B344
1853 B345
1854 B346
1855 B347
1856 B348
1857 B349
1858 B350
1859 B351
1860 B352
1861 B353
1862 B354
1863 B355
1864 B356
1865 B357
1866 B358
1867 B359
1868 B360
1869 B361
1870 B362
1871 B363
1872 B364
1873 B365
1874 B366
1875 B367
1876 B368
1877 B369
1878 B370
1879 B371
1880 B372
1881 B373
1882 B374
1883 B375
1884 B376
1885 B377
1886 B378
1887 B379
1888 B380
1889 B381
1890 B382
1891 B383
1892 B384
1893 B385
1894 B386
1895 B387
1896 B388
1897 B389
1898 B390
1899 B391
1900 B392
1901 B393
1902 B394
1903 B395
1904 B396
1905 B397
1906 B398
1907 B399
1908 B400
1909 B401
1910 B402
1911 B403
1912 B404
1913 B405
1914 B406
1915 B407
1916 B408
1917 B409
1918 B410
1919 B411
1920 B412
1921 B413
1922 B414
1923 B415
1924 B416
1925 B417
1926 B418
1927 B419
1928 B420
1929 B421
1930 B422
1931 B423
1932 B424
1933 B425
1934 B426
1935 B427
1936 B428
1937 B429
1938 B430
1939 B431
1940 B432
1941 B433
1942 B434
1943 B435
1944 B436
1945 B437
1946 B438
1947 B439
1948 B440
1949 B441
1950 B442
1951 B443
1952 B444
1953 B445
1954 B446
1955 B447
1956 B448
1957 B449
1958 B450
1959 B451
1960 B452
1961 B453
1962 B454
1963 B455
1964 B456
1965 B457
1966 B458
1967 B459
1968 B460
1969 B461
1970 B462
1971 B463
1972 B464
1973 B465
1974 B466
1975 B467
1976 B468
1977 B469
1978 B470
1979 B471
1980 B472
1981 B473
1982 B474
1983 B475
1984 B476
1985 B477
1986 B478
1987 B479
1988 B480
1989 B481
1990 B482
1991 B483
1992 B484
1993 B485
1994 B486
1995 B487
1996 B488
1997 B489
1998 B490
1999 B491
2000 B492
2001 B493
2002 B494
2003 B495
2004 B496
2005 B497
2006 B498
2007 B499
2008 B500
2009 B501
2010 B502
2011 B503
2012 B504
2013 B505
2014 B506
2015 B507
2016 B508
2017 B509
2018 B510
2019 B511
2020 B512
2021 B513
2022 B514
2023 B515
2024 B516
2025 B517
2026 B518
2027 B519
2028 B520
2029 B521
2030 B522
2031 B523
2032 B524
2033 B525
2034 B526
2035 B527
2036 B528
2037 B529
2038 B530
2039 B531
2040 B532
2041 B533
2042 B534
2043 B535
2044 B536
2045 B537
2046 B538
2047 B539
2048 B540
2049 B541
2050 B542
2051 B543
2052 B544
2053 B545
2054 B546
2055 B547
2056 B548
2057 B549
2058 B550
2059 B551
2060 B552
2061 B553
2062 B554
2063 B555
2064 B556
2065 B557
2066 B558
2067 B559
2068 B560
2069 B561
2070 B562
2071 B563
2072 B564
2073 B565
2074 B566
2075 B567
2076 B568
2077 B569
2078 B570
2079 B571
2080 B572
2081 B573
2082 B574
2083 B575
2084 B576
2085 B577
2086 B578
2087 B579
2088 B580
2089 B581
2090 B582
2091 B583
2092 B584
2093 B585
2094 B586
2095 B587
2096 B588
2097 B589
2098 B590
2099 B591
2100 B592
2101 B593
2102 B594
2103 B595
2104 B596
2105 B597
2106 B598
2107 B599
2108 B600
2109 B601
2110 B602
2111 B603
2112 B604
2113 B605
2114 B606
2115 B607
2116 B608
2117 B609
2118 B610
2119 B611
2120 B612
2121 B613
2122 B614
2123 B615
2124 B616
2125 B617
2126 B618
2127 B619
2128 B620
2129 B621
2130 B622
2131 B623
2132 B624
2133 B625
2134 B626
2135 B627
2136 B628
2137 B629
2138 B630
2139 B631
2140 B632
2141 B633
2142 B634
2143 B635
2144 B636
2145 B637
2146 B638
2147 B639
2148 B640
2149 B641
2150 B642
2151 B643
2152 B644
2153 B645
2154 B646
2155 B647
2156 B648
2157 B649
2158 B650
2159 B651
2160 B652
2161 B653
2162 B654
2163 B655
2164 B656
2165 B657
2166 B658
2167 B659
2168 B660
2169 B661
2170 B662
2171 B663
2172 B664
2173 B665
2174 B666
2175 B667
2176 B668
2177 B669
2178 B670
2179 B671
2180 B672
2181 B673
2182 B674
2183 B675
2184 B676
2185 B677
2186 B678
2187 B679
2188 B680
2189 B681
2190 B682
2191 B683
2192 B684
2193 B685
2194 B686
2195 B687
2196 B688
2197 B689
2198 B690
2199 B691
2200 B692
2201 B693
2202 B694
2203 B695
2204 B696
2205 B697
2206 B698
2207 B699
2208 B700
2209 B701
2210 B702
2211 B703
2212 B704
2213 B705
2214 B706
2215 B707
2216 B708
2217 B709
2218 B710
2219 B711
2220 B712
2221 B713
2222 B714
2223 B715
2224 B716
2225 B717
2226 B718
2227 B719
2228 B720
2229 B721
2230 B722
2231 B723
2232 B724
2233 B725
2234 B726
2235 B727
2236 B728
2237 B729
2238 B730
2239 B731
2240 B732
2241 B733
2242 B734
2243 B735
2244 B736
2245 B737
2246 B738
2247 B739
2248 B740
2249 B741
2250 B742
2251 B743
2252 B744
2253 B745
2254 B746
2255 B747
2256 B748
2257 B749
2258 B750
2259 B751
2260 B752
2261 B753
2262 B754
2263 B755
2264 B756
2265 B757
2266 B758
2267 B759
2268 B760
2269 B761
2270 B762
2271 B763
2272 B764
2273 B765
2274 B766
2275 B767
2276 B768
2277 B769
2278 B770
2279 B771
2280 B772
2281 B773
2282 B774
2283 B775
2284 B776
2285 B777
2286 B778
2287 B779
2288 B780
2289 B781
2290 B782
2291 B783
2292 B784
2293 B785
2294 B786
2295 B787
2296 B788
2297 B789
2298 B790
22

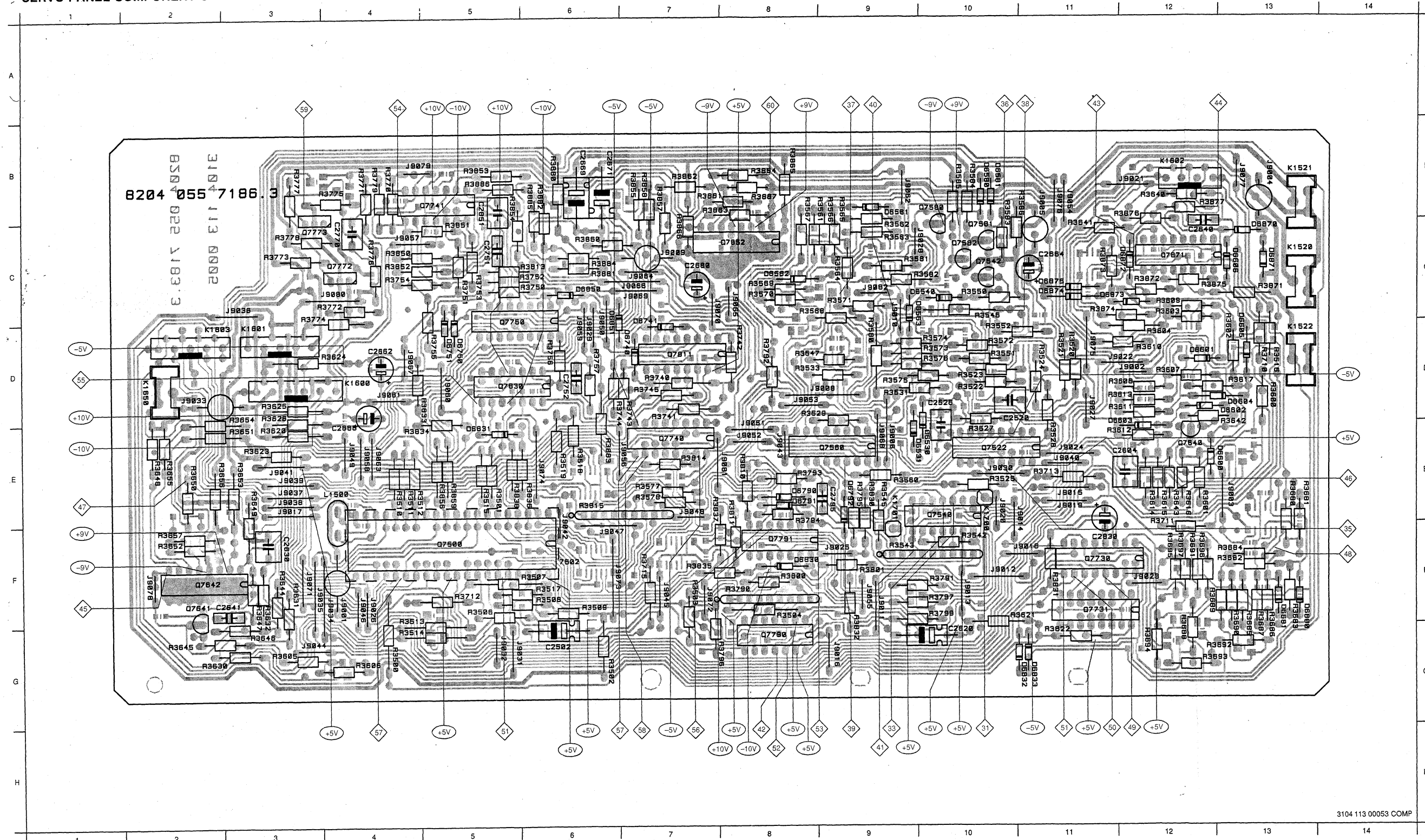

C2502	G6	J
C2520	E10	J
C2526	D10	J
C2604	E12	J
C2620	G10	J
C2630	F3	J
C2640	C12	J
C2641	F3	J
C2660	C7	J
C2662	D4	J
C2664	C11	J
C2666	E4	J
C2669	B6	J
C2671	B6	J
C2751	C5	J
C2752	C4	J
C2770	D6	J
C2795	E9	J
C2830	F11	J
C2851	B5	J
D6530	E10	J
D6531	E9	J
D6540	C10	J
D6561	B9	J
D6562	C8	J
D6563	C9	J
D6580	B10	J
D6581	B10	J
D6600	E13	J
D6601	D12	J
D6602	D13	J
D6603	E12	J
D6604	D13	J
D6605	D13	J
D6606	C13	J
D6680	F13	J
D6681	F13	J
D6740	D7	J
D6741	D7	J
D6750	D5	J
D6751	D5	J
D6790	E8	J
D6791	E8	J
D6792	E9	J
D6830	F8	J
D6831	E5	J
D6832	G11	J
D6833	G11	J
D6850	C6	J
D6851	D6	J
D6870	C13	J
D6871	C13	J
D6872	C12	J
D6873	C11	J
D6874	C11	J
D6875	C11	J
J9001	F4	J
J9002	D12	J
J9003	E13	J
J9004	B13	J
J9005	B11	J
J9006	E9	J
J9009	C7	J
J9010	C9	J
J9011	F9	J
J9012	F10	J
J9013	F10	J
J9014	F11	J
J9015	E11	J
J9016	G9	J

3104 113 00053 COMP

3104 113 00053 COMP

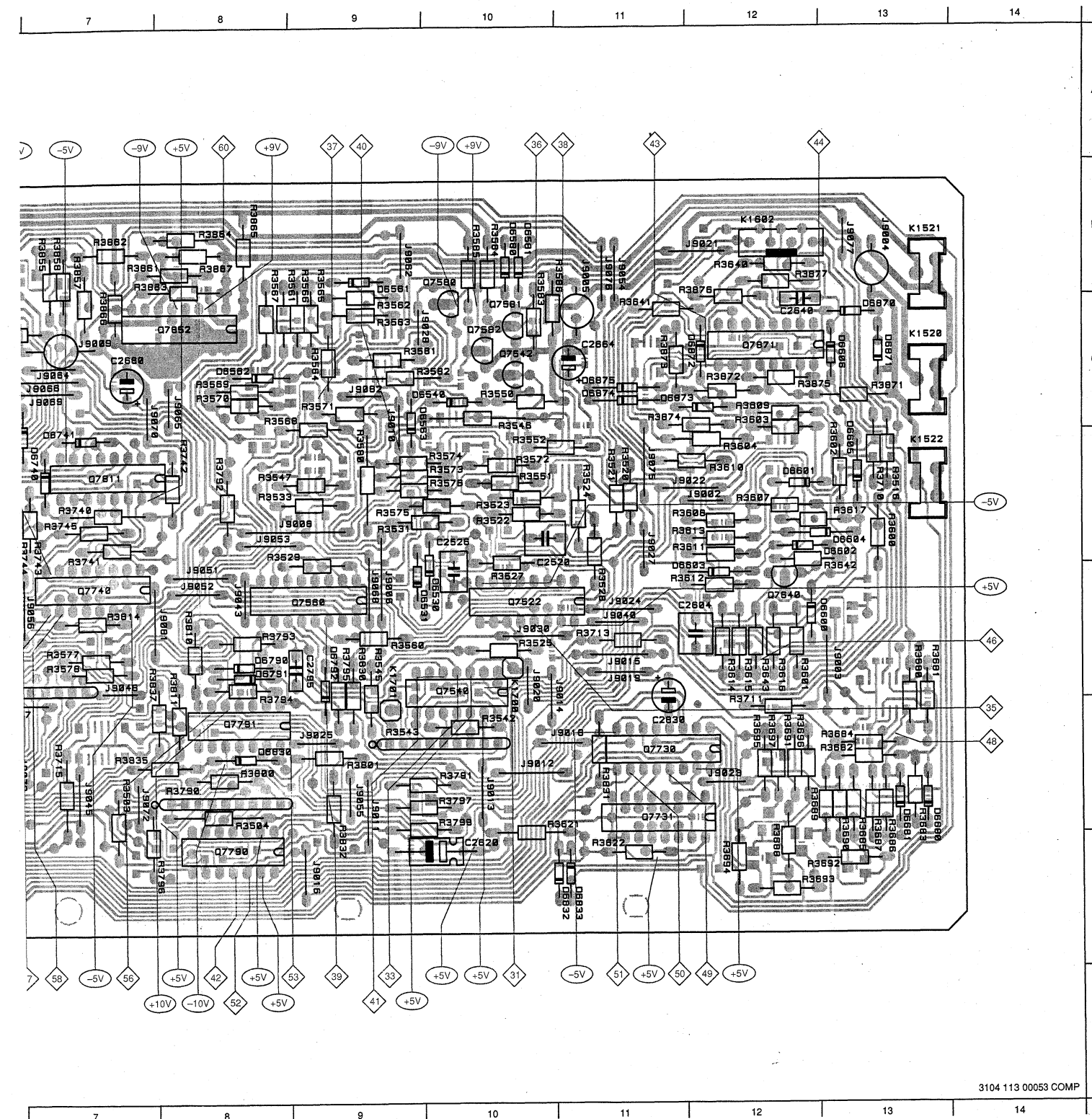

C2502	G6	J9017	E3	K1520	C13	R3551	D10	R3650	E2	R3800	F8
C2520	E10	J9018	F11	K1521	B13	R3550	E9	R3651	E3	R3801	F9
C2526	D10	J9019	E11	K1522	D13	R3562	C9	R3652	F2	R3810	E8
C2604	E12	J9020	E10	K1600	D4	R3563	C9	R3653	E3	R3811	E8
C2620	G10	J9021	B12	K1601	D3	R3564	C9	R3654	D3	R3813	C6
C2630	F3	J9022	D11	K1602	B12	R3565	B9	R3655	E2	R3814	E7
C2640	C12	J9023	F12	K1603	D2	R3566	B9	R3657	F2	R3815	E6
C2641	F3	J9024	E11	K1650	D2	R3567	B8	R3658	E2	R3830	E9
C2660	D7	J9025	F9	K1700	E10	R3568	C8	R3669	F12	R3831	F11
C2662	C4	J9026	F4	K1701	E9	R3569	C8	R3681	E13	R3832	G9
C2664	C11	J9027	D11	L1500	E4	R3570	C8	R3682	F13	R3833	D5
C2666	E4	J9028	C10	Q7500	F5	R3571	C9	R3683	F13	R3834	E5
C2669	B6	J9029	D6	Q7522	E10	R3572	D10	R3684	F13	R3835	F7
C2671	B6	J9030	E10	Q7540	E10	R3573	D10	R3685	G13	R3836	E6
C2751	C5	J9031	G5	Q7542	C10	R3574	D10	R3686	G13	R3837	E7
C2752	D6	J9032	G5	Q7560	E9	R3575	D9	R3687	G13	R3838	E5
C2770	C4	J9033	D2	Q7580	B10	R3576	D10	R3688	G12	R3851	C5
C2795	E9	J9034	F4	Q7581	C10	R3577	E7	R3690	G13	R3852	C4
C2830	F11	J9035	F3	Q7582	C10	R3578	E7	R3691	F12	R3853	B5
C2851	B5	J9036	C3	Q7640	E12	R3580	D9	R3692	G13	R3854	B5
D6530	E10	J9037	E3	Q7641	F2	R3581	C9	R3693	G12	R3855	B7
D6531	E9	J9038	E3	Q7642	F2	R3581	B9	R3694	G12	R3856	E5
D6540	C10	J9039	E3	Q7730	F11	R3582	C10	R3695	F12	R3857	B7
D6561	B9	J9040	E11	Q7731	F11	R3583	C10	R3696	F12	R3858	B7
D6562	C8	J9041	E3	Q7740	E7	R3584	B10	R3697	F12	R3859	E5
D6563	C9	J9042	F6	Q7741	B5	R3585	B10	R3710	D13	R3860	C6
D6580	B10	J9043	E8	Q7750	D5	R3586	B11	R3711	F12	R3861	B7
D6581	B10	J9044	G3	Q7772	C4	R3600	E13	R3712	F5	R3862	B7
D6600	E13	J9045	F7	Q7773	C3	R3600	D13	R3713	E11	R3863	B8
D6601	D12	J9046	F4	Q7790	G8	R3600	D12	R3715	F7	R3864	B8
D6602	D13	J9047	F6	Q7791	F8	R3601	E12	R3740	D7	R3865	B8
D6603	E12	J9048	E7	Q7811	D7	R3602	D13	R3741	D7	R3866	C7
D6604	D13	J9049	E4	Q7830	D5	R3603	C12	R3742	D8	R3867	B8
D6605	D13	J9050	D6	Q7852	C8	R3604	D12	R3743	D7	R3871	C13
D6606	C13	J9051	E8	Q7871	C12	R3605	G3	R3744	D6	R3872	C12
D6680	F13	J9052	E8	R2552	D10	R3606	G4	R3745	D7	R3873	C11
D6681	F13	J9053	D8	R3050	C4	R3607	D12	R3750	C6	R3874	C11
D6740	D7	J9054	B11	R3500	G4	R3609	C12	R3751	C5	R3875	C12
D6741	D7	J9055	F9	R3501	E5	R3610	D12	R3752	C6	R3876	B12
D6750	D5	J9056	E7	R3502	G6	R3611	D12	R3753	C5	R3877	B12
D6751	D5	J9057	C4	R3503	F7	R3612	E12	R3754	C4	R3880	B6
D6790	E8	J9058	E4	R3504	F8	R3613	D12	R3755	D5	R3881	C6
D6791	E8	J9059	D6	R3506	F5	R3614	E12	R3756	D6	R3882	B6
D6792	E9	J9060	D5	R3507	F6	R3615	E12	R3757	D6	R3883	E6
D6830	F8	J9061	D4	R3508	F6	R3616	E12	R3770	B4	R3884	C6
D6831	E5	J9062	B9	R3509	F6	R3617	D13	R3771	B4	R3885	B6
D6832	G11	J9063	E4	R3510	E4	R3620	E3	R3772	C4	R3886	B5
D6833	G11	J9064	C7	R3511	E4	R3621	G10	R3773	C3		
D6850	C6	J9065	C8	R3512	E4	R3622	G11	R3774	C3		
D6851	D6	J9066	C7	R3513	G4	R3623	E3	R3775	B4		
D6870	C13	J9067	D4	R3514	G4	R3624	D4	R3776	C4		
D6871	C13	J9068	E9	R3515	E5	R3625	D3	R3777	B3		
D6872	C12	J9069	C7	R3516	D13	R3626	D3	R3778	C3		
D6873	C11	J9070	C7	R3517	F6	R3630	G2	R3779	B4		
D6874	C11	J9070	B4	R3518	E6	R3631	F3	R3790	F8		
D6875	C11	J9071	F3	R3519	E6	R3632	F3	R3791	F10		
J9001	F4	J9072	F7	R3520	D11	R3640	B12	R3792	D8		
J9002	D12	J9073	F6	R3521	D11	R3641	C11	R3793	E8		
J9003	E13	J9074	E6	R3522	D10	R3642	E13	R3794	F8		
J9004	B13	J9075	D11	R3523	D10	R3643	E12	R3795	E9		
J9005	B11	J9076	B11	R3524	D11	R3644	F3	R3796	G8		
J9006	E9	J9077	B13	R3525	E10	R3645	G2	R3797	F10		
J9009	C7	J9078	F2	R3527	E10	R3646	G3	R3799	F10		
J9010	C9	J9080	C4	R3528	E11	R3647	F3				
J9011	F9	J9081	E8	R3529	D8	R3648	E2				
J9012	F10	J9082	C9	R3531	D9	R3649	E3				
J9013	F10			R3533	D8						
J9014	F11			R3542	F10						
J9015	E11			R3543	F9						
J9016	G9			R3545	E9						
				R3546	C10						
				R3547	D8						
				R3550	C10						

3104 113 00053 COMP

3104 113 00053 COMP

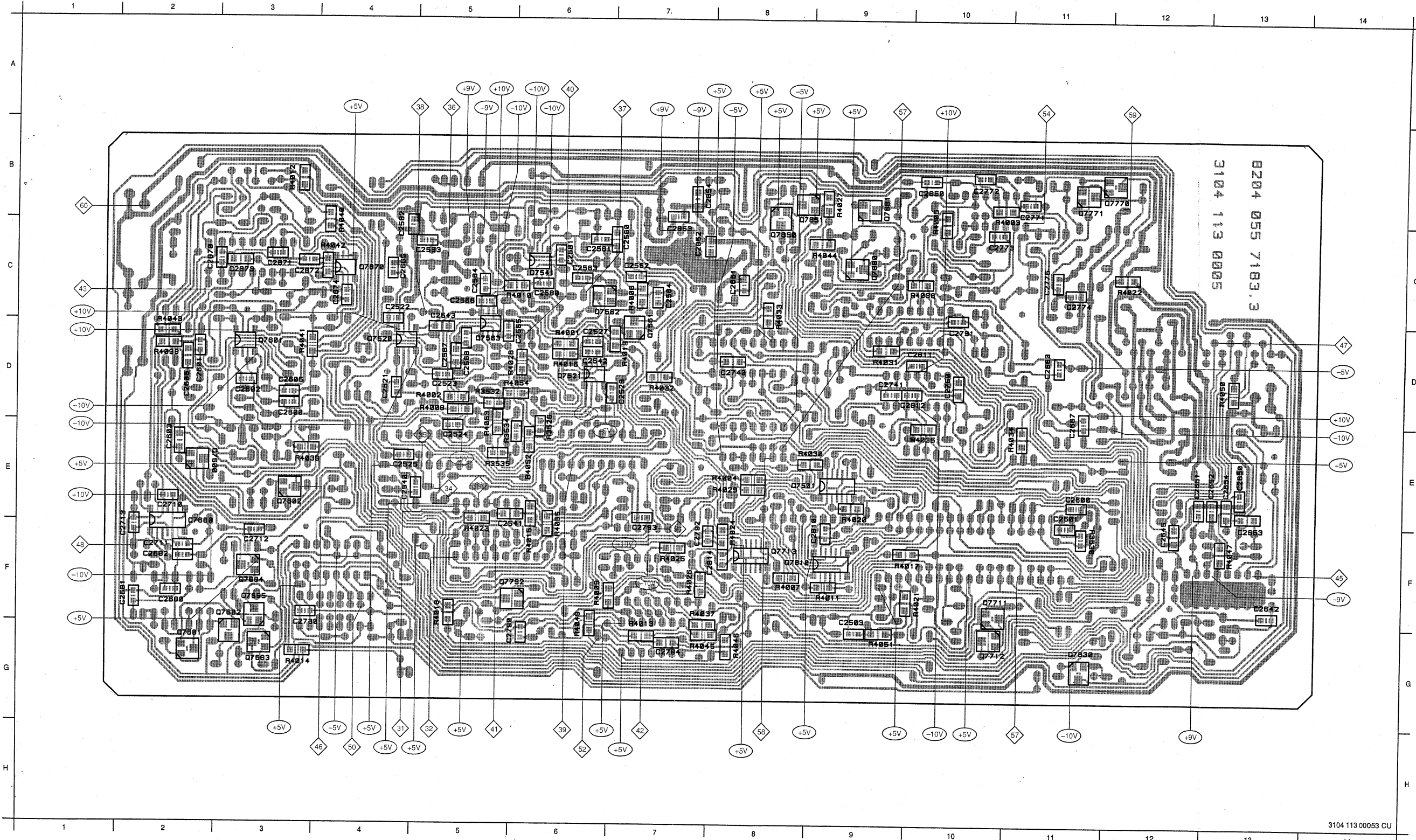

- C2500 E11
- C2501 E11
- C2503 G9
- C2521 D4
- C2522 C4
- C2523 D5
- C2524 E5
- C2525 E4
- C2527 D6
- C2528 D7
- C2540 E4
- C2541 F5
- C2542 D6
- C2543 C5
- C2560 C7
- C2561 C6
- C2562 C7
- C2563 C6
- C2564 C7
- C2565 D6
- C2566 C5
- C2567 D5
- C2568 D5
- C2581 C6
- C2582 C4
- C2583 C5
- C2584 C5
- C2600 D3
- C2601 D2
- C2602 D3
- C2603 E2
- C2605 D3
- C2606 D2
- C2642 F13
- C2645 F12
- C2650 E13
- C2651 E12
- C2652 E13
- C2653 F13
- C2654 E13
- C2661 C8
- C2663 D11
- C2665 C4
- C2667 E11
- C2680 F2
- C2681 F2
- C2682 F2
- C2710 E2
- C2711 F2
- C2712 F3
- C2713 F2
- C2730 G3
- C2740 D8
- C2741 D9
- C2750 D10
- C2771 B11
- C2772 B10
- C2773 C10
- C2774 C11
- C2775 C11
- C2790 G6
- C2791 D10
- C2793 F7
- C2794 G7
- C2810 F9
- C2811 D10
- C2812 D10
- C2814 F8

3104 113 00053 CU

3104 113 00053 CU

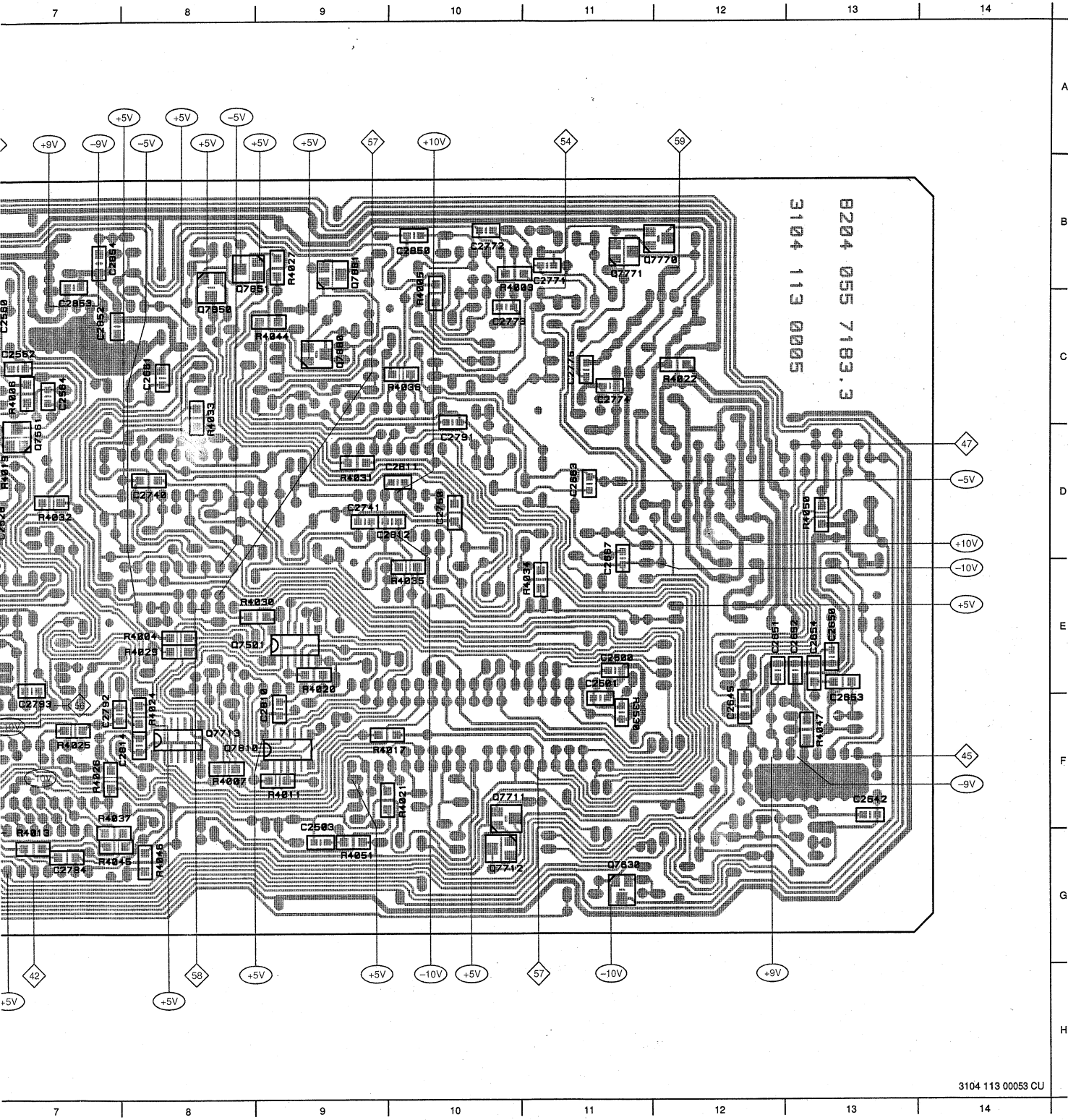

3104 113 0005 CU

3104 113 0005 CU

C2500	E11	C2850	B10	R4027	B9
C2501	E11	C2852	C7	R4028	D6
C2503	G9	C2853	C7	R4029	E8
C2521	D4	C2854	B7	R4030	E9
C2522	C4	C2870	C3	R4031	D9
C2523	D5	C2871	C3	R4032	D7
C2524	E5	C2872	C3	R4033	C8
C2525	E4	C2873	C3	R4034	E11
C2527	D6	C2874	C4	R4035	E10
C2528	D7	C7292	F7	R4036	C10
C2540	E4	Q7501	E9	R4037	F7
C2541	F5	Q7520	D4	R4038	D2
C2542	D6	Q7521	D6	R4039	E3
C2543	C5	Q7541	C6	R4040	C4
C2560	C7	Q7561	D7	R4041	D3
C2561	C6	Q7562	C6	R4042	C4
C2562	C7	Q7563	D5	R4043	D2
C2563	C6	Q7600	E2	R4044	C9
C2564	C7	Q7601	G2	R4045	G7
C2565	D6	Q7601	D3	R4046	G8
C2566	C5	Q7602	E3	R4047	F13
C2567	D5	Q7630	G11	R4049	G6
C2568	D5	Q7680	F2	R4050	D13
C2581	C6	Q7682	F3	R4051	G9
C2582	C4	Q7683	G3	R4052	E6
C2583	C5	Q7684	F3	R4053	E5
C2584	C5	Q7685	F3	R4054	D6
C2600	D3	Q7711	F10	R4055	F6
C2601	D2	Q7712	G10		
C2602	D3	Q7713	F8		
C2603	E2	Q7770	B12		
C2605	D3	Q7771	B11		
C2606	D2	Q7792	F6		
C2642	F13	Q7810	F8		
C2645	F12	Q7850	C8		
C2650	E13	Q7851	B8		
C2651	E12	Q7870	C4		
C2652	E13	Q7880	C9		
C2653	F13	Q7881	B9		
C2654	E13	R3526	E6		
C2661	C8	R3530	F11		
C2663	D11	R3532	D5		
C2665	C4	R3534	E5		
C2667	E11	R3535	E5		
C2680	F2	R4001	D6		
C2681	F2	R4002	D5		
C2682	F2	R4003	B10		
C2710	E2	R4004	E8		
C2711	F2	R4005	C10		
C2712	F3	R4006	C7		
C2713	F2	R4007	F8		
C2730	G3	R4008	D5		
C2740	D8	R4009	F6		
C2741	D9	R4010	C6		
C2750	D10	R4011	F9		
C2771	B11	R4012	B3		
C2772	B10	R4013	G7		
C2773	C10	R4014	G3		
C2774	C11	R4015	F6		
C2775	C11	R4016	D6		
C2790	G6	R4017	F9		
C2791	D10	R4018	F5		
C2793	F7	R4019	D7		
C2794	G7	R4020	E9		
C2810	F9	R4021	F10		
C2811	D10	R4022	C12		
C2812	D10	R4023	F5		
C2814	F8	R4024	F8		
		R4025	F7		
		R4026	F7		

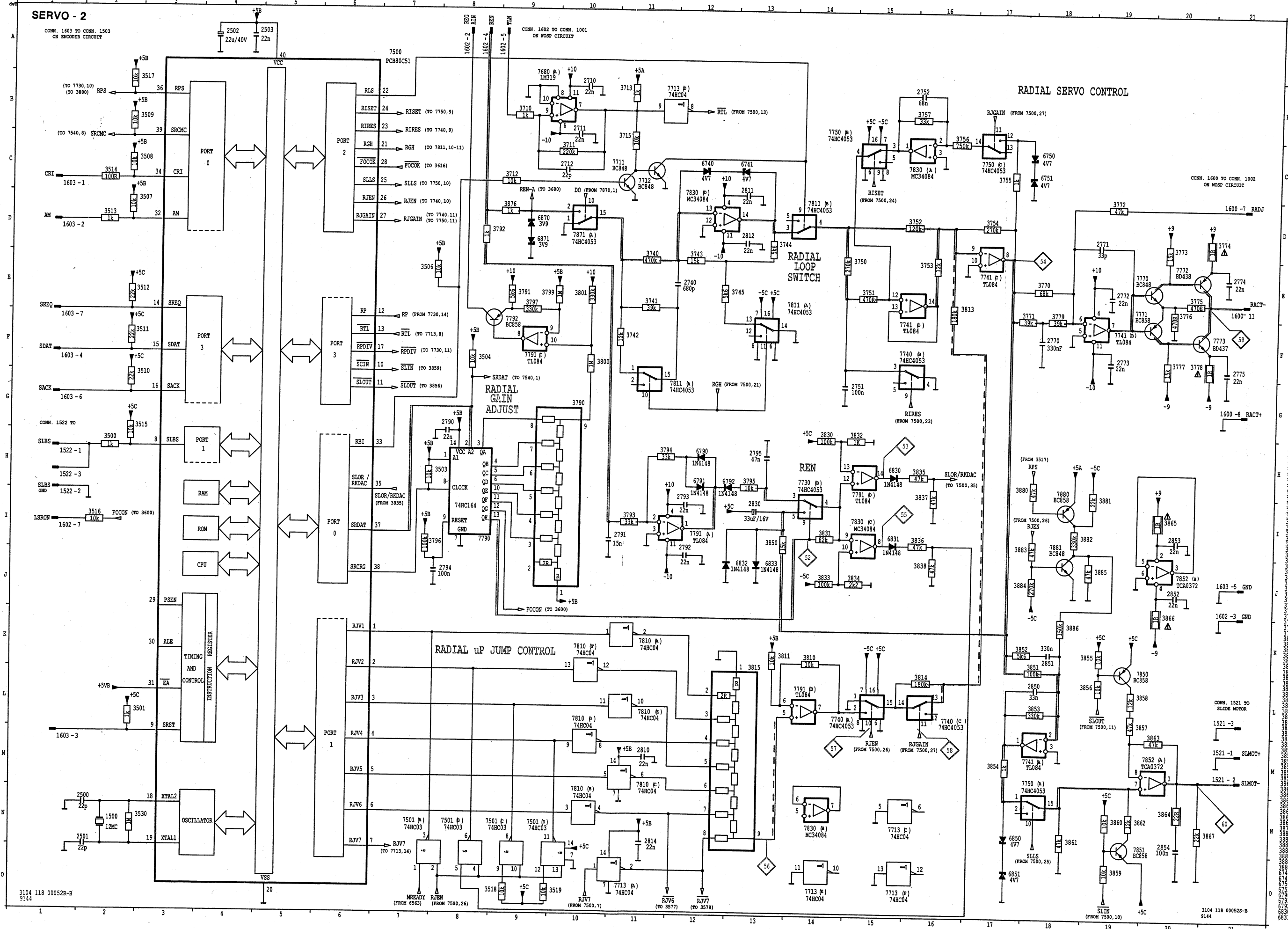

3104 118 00052R-B
9144

1500	N 2	6832
1501	M 1	6833
1502	L 1	6834
1503	K 1	6835
1504	J 1	6836
1505	I 1	6837
1506	H 1	6838
1507	G 1	6839
1508	F 1	6840
1509	E 1	6841
1510	D 1	6842
1511	C 1	6843
1512	B 1	6844
1513	A 1	6845
1514	Z 1	6846
1515	Y 1	6847
1516	X 1	6848
1517	W 1	6849
1518	V 1	6850
1519	U 1	6851
1520	T 1	6852
1521	S 1	6853
1522	R 1	6854
1523	Q 1	6855
1524	P 1	6856
1525	O 1	6857
1526	N 1	6858
1527	M 1	6859
1528	L 1	6860
1529	K 1	6861
1530	J 1	6862
1531	I 1	6863
1532	H 1	6864
1533	G 1	6865
1534	F 1	6866
1535	E 1	6867
1536	D 1	6868
1537	C 1	6869
1538	B 1	6870
1539	A 1	6871
1540	Z 1	6872
1541	Y 1	6873
1542	X 1	6874
1543	W 1	6875
1544	V 1	6876
1545	U 1	6877
1546	T 1	6878
1547	S 1	6879
1548	R 1	6880
1549	Q 1	6881
1550	P 1	6882
1551	O 1	6883
1552	N 1	6884
1553	M 1	6885
1554	L 1	6886
1555	K 1	6887
1556	J 1	6888
1557	I 1	6889
1558	H 1	6890
1559	G 1	6891
1560	F 1	6892
1561	E 1	6893
1562	D 1	6894
1563	C 1	6895
1564	B 1	6896
1565	A 1	6897
1566	Z 1	6898
1567	Y 1	6899
1568	X 1	6900
1569	W 1	6901
1570	V 1	6902
1571	U 1	6903
1572	T 1	6904
1573	S 1	6905
1574	R 1	6906
1575	Q 1	6907
1576	P 1	6908
1577	O 1	6909
1578	N 1	6910
1579	M 1	6911
1580	L 1	6912
1581	K 1	6913
1582	J 1	6914
1583	I 1	6915
1584	H 1	6916
1585	G 1	6917
1586	F 1	6918
1587	E 1	6919
1588	D 1	6920
1589	C 1	6921
1590	B 1	6922
1591	A 1	6923
1592	Z 1	6924
1593	Y 1	6925
1594	X 1	6926
1595	W 1	6927
1596	V 1	6928
1597	U 1	6929
1598	T 1	6930
1599	S 1	6931
1600	R 1	6932
1601	Q 1	6933
1602	P 1	6934
1603	O 1	6935
1604	N 1	6936
1605	M 1	6937
1606	L 1	6938
1607	K 1	6939
1608	J 1	6940
1609	I 1	6941
1610	H 1	6942
1611	G 1	6943
1612	F 1	6944
1613	E 1	6945
1614	D 1	6946
1615	C 1	6947
1616	B 1	6948
1617	A 1	6949
1618	Z 1	6950
1619	Y 1	6951
1620	X 1	6952
1621	W 1	6953
1622	V 1	6954
1623	U 1	6955
1624	T 1	6956
1625	S 1	6957
1626	R 1	6958
1627	Q 1	6959
1628	P 1	6960
1629	O 1	6961
1630	N 1	6962
1631	M 1	6963
1632	L 1	6964
1633	K 1	6965
1634	J 1	6966
1635	I 1	6967
1636	H 1	6968
1637	G 1	6969
1638	F 1	6970
1639	E 1	6971
1640	D 1	6972
1641	C 1	6973
1642	B 1	6974
1643	A 1	6975
1644	Z 1	6976
1645	Y 1	6977
1646	X 1	6978
1647	W 1	6979
1648	V 1	6980
1649	U 1	6981
1650	T 1	6982
1651	S 1	6983
1652	R 1	6984
1653	Q 1	6985
1654	P 1	6986
1655	O 1	6987
1656	N 1	6988
1657	M 1	6989
1658	L 1	6990
1659	K 1	6991
1660	J 1	6992
1661	I 1	6993
1662	H 1	6994
1663	G 1	6995
1664	F 1	6996
1665	E 1	6997
1666	D 1	6998
1667	C 1	6999
1668	B 1	7000
1669	A 1	7001
1670	Z 1	7002
1671	Y 1	7003
1672	X 1	7004
1673	W 1	7005
1674	V 1	7006
1675	U 1	7007
1676	T 1	7008
1677	S 1	7009
1678	R 1	7010
1679	Q 1	7011
1680	P 1	7012
1681	O 1	7013
1682	N 1	7014
1683	M 1	7015
1684	L 1	7016
1685	K 1	7017
1686	J 1	7018
1687	I 1	7019
1688	H 1	7020
1689	G 1	7021
1690	F 1	7022
1691	E 1	7023
1692	D 1	7024
1693	C 1	7025
1694	B 1	7026
1695	A 1	7027
1696	Z 1	7028
1697	Y 1	7029
1698	X 1	7030
1699	W 1	7031
1700	V 1	7032

3104 118 00052R-B
9144

SERVO-2

- AM - Additional Mute
- CRI - Counter Reset Inhibit
- FOCOK - In Focus Signal
- FOCON - Focus On
- GND - Ground
- LSRON - Laser On
- MREADY - Turntable Motor Ready
- RADJ+ - Radial Actuator
- RADJ- - Radial Gain Adjust
- RBI - Radial Brake Inhibit
- REGAIN - Radial Gain Current
- REN - Radial Error Normalized
- REN-A - Radial Error Normalized A
- RGH - Radial Gain High
- RIRES - Radial Integrator Reset
- RISET - Radial Integrator Preset
- RJEN - Radial Jump Enable
- RJGAIN - Radial Jump Gain
- RJV1-7 - Radial Jump Voltage
- RLS - Radial Loop Switch
- RP - Radial Polarity
- RPDIV - Radial Polarity Divider
- RTL - Radial Track Loss
- SACK - Servo Acknowledge
- SDAT - Servo Data
- SLBS - Slide Begin Switch
- SLIN - Slide Inwards Pulse
- SLLS - Slide Servo Loops Switch
- SLMOT+ - Slide Motor
- SLOR/RKDAC - Slide Outwards Request/ADC Determination Radial Amplitude
- SLOUT - Slide Outwards Pulse
- SRCRG - Shift Register Clock Radial Gain
- SRDAT - Shift Register Data
- SREQ - Servo Request
- SRST - Servo Reset
- TLN - Trackloss Normalized

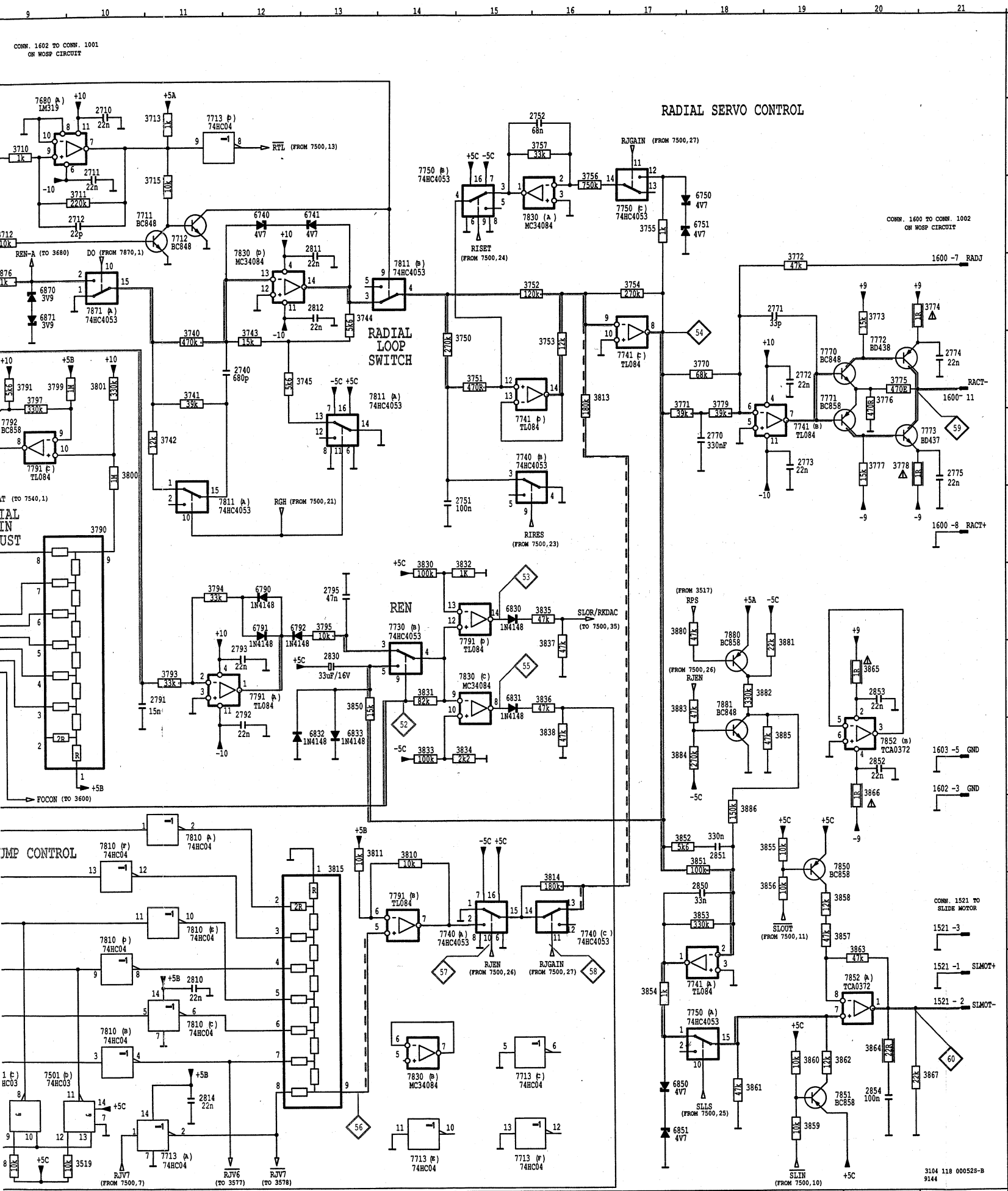
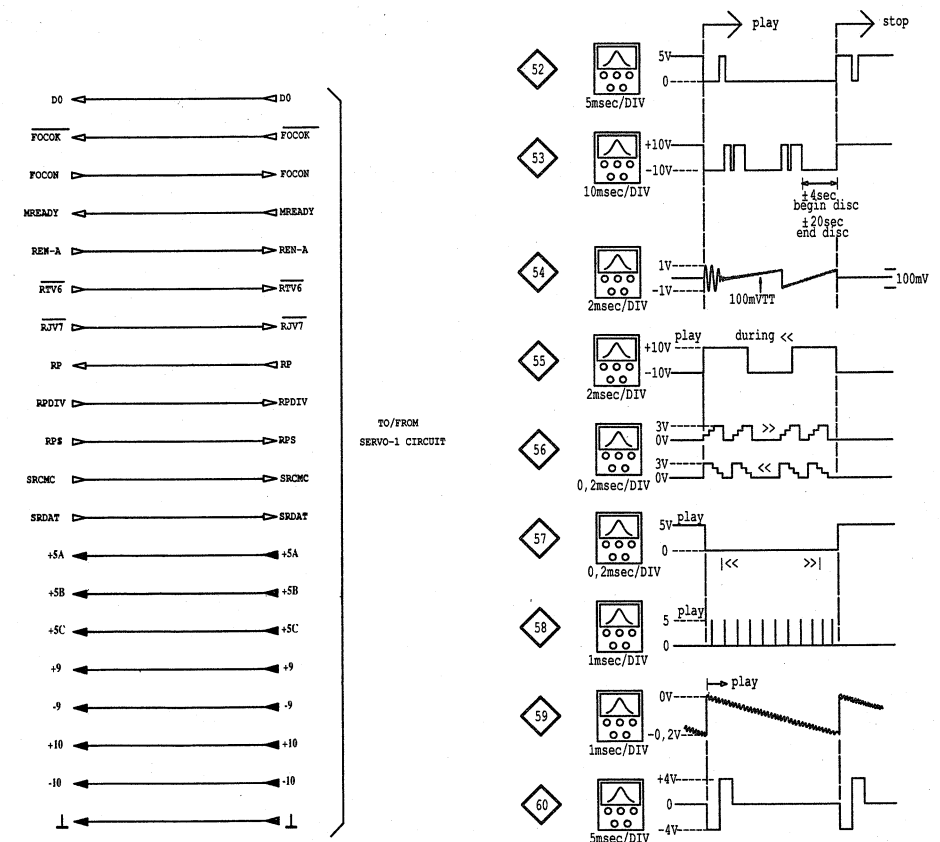

WOSP CIRCUIT DIAGRAM

WOSP - 1

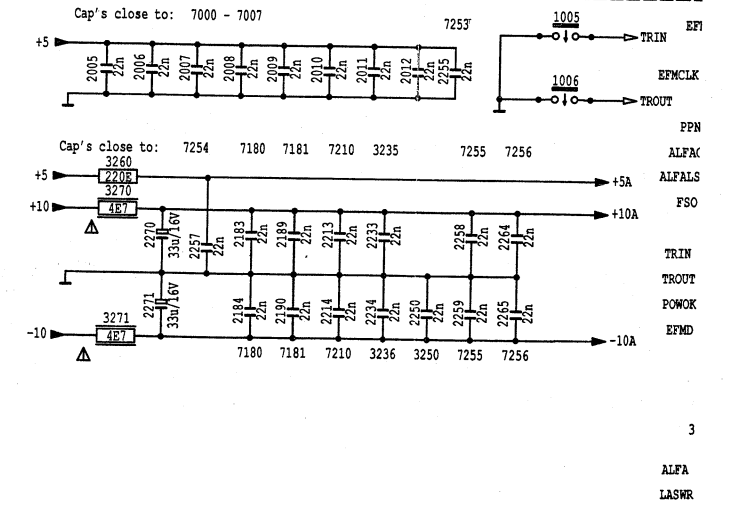
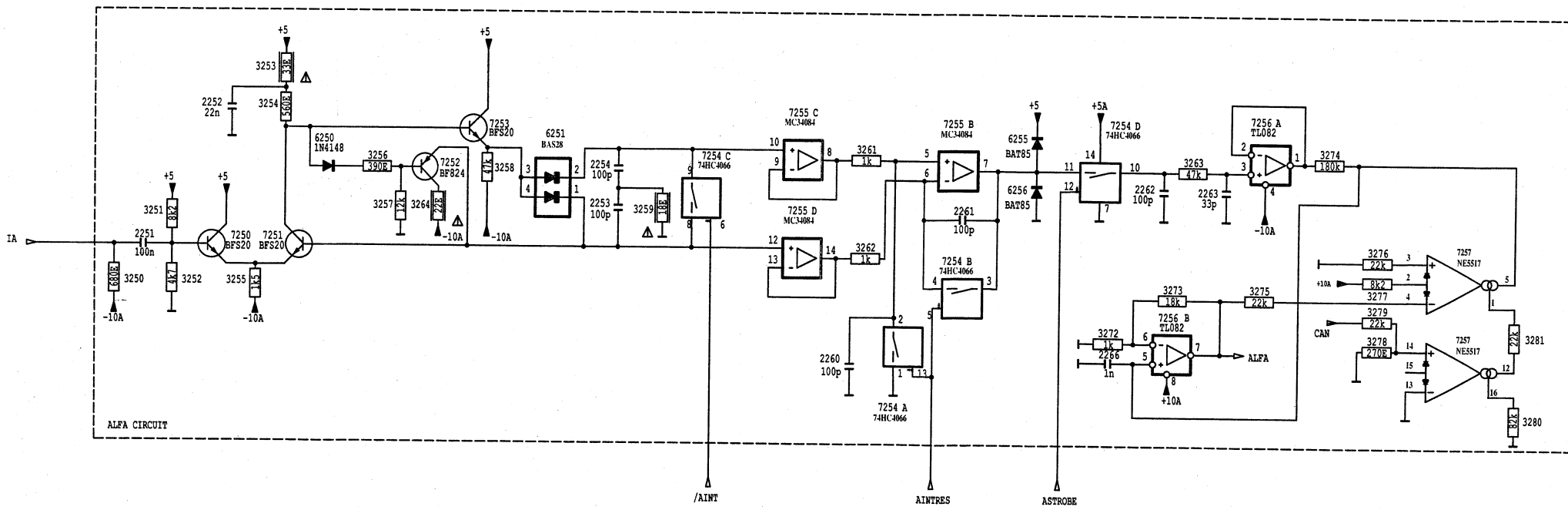
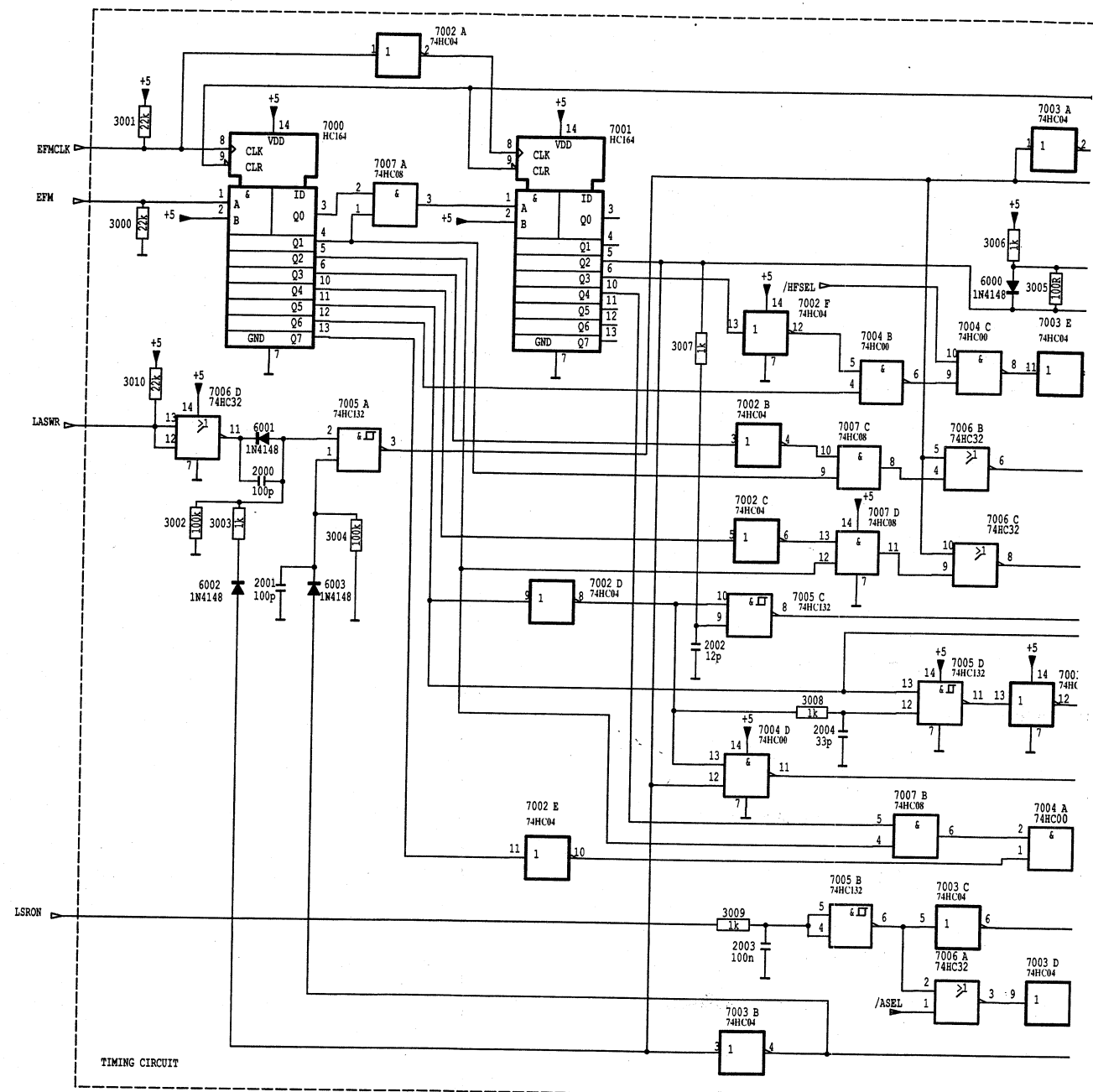
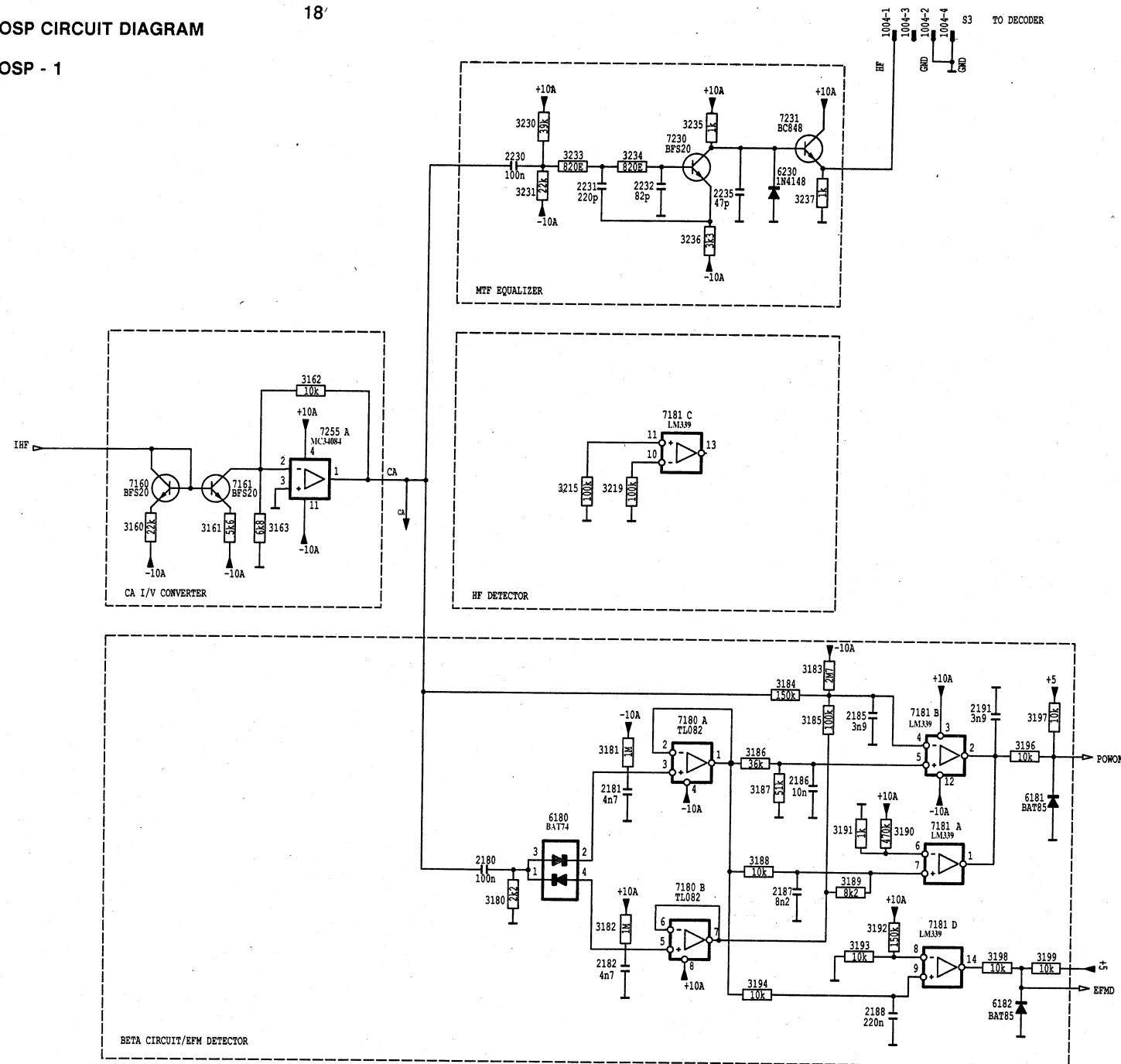

WOSP PANEL COMPONENT SIDE

1000 E11	2011 F7	2101 B5	2120 B5	2232 B2	2270 A9	3021 E10	3041 D9	3060 C8	3113 C6	3132 A4	3188 E2	3237 B2	3272 D5	6024 D8	6104 D5	7005 E7	7038 C8	7142 B5
1001 A2	2012 E9	2102 B7	2121 B5	2233 A3	2271 A9	3022 E7	3042 D9	3061 C7	3114 D4	3133 A5	3189 E2	3238 C1	3273 D2	6025 D9	6105 B5	7006 F6	7039 D8	7143 B4
1002 A10	2020 D6	2103 C6	2122 C6	2234 B2	2272 B9	3023 E5	3043 D9	3062 C8	3115 C4	3134 A6	3190 E2	3239 C4	3274 D2	6026 D9	6106 D5	7007 E8	7040 C9	7144 B4
1003 B6	2021 B9	2104 C6	2123 B2	2235 C5	2273 B9	3024 E7	3044 D9	3063 C8	3116 B5	3135 A5	3191 E2	3240 D5	3275 D2	6027 C9	6107 C3	7008 E6	7041 D8	7145 B2
1004 B1	2022 B8	2105 B7	2124 B2	2236 C4	2274 B9	3025 D6	3045 C9	3064 B10	3117 B5	3136 A6	3192 D2	3241 D5	3276 D5	6028 C9	6108 C2	7009 D7	7042 C8	7146 B2
1005 F3	2023 D9	2106 B5	2125 E2	2237 C4	2275 B9	3026 E6	3046 B9	3065 B8	3118 B9	3137 A7	3193 D2	3242 D5	3277 F2	6029 B8	6109 C5	7010 D6	7043 C8	7147 B2
1006 F4	2024 D8	2107 B6	2126 F2	2238 C4	3000 D10	3027 B9	3047 C9	3066 B8	3119 C7	3138 A8	3194 D2	3243 D4	3278 D5	6030 D7	6110 E2	7011 D6	7044 D8	7231 A2
1007 A4	2025 B7	2108 D4	2127 F3	2239 C4	3001 E10	3028 C10	3048 C10	3067 B8	3120 C6	3139 A9	3195 F4	3244 D4	3279 D3	6031 D7	6111 E10	7012 D8	7045 D8	7250 C4
2000 F6	2026 C7	2109 C7	2128 F3	2240 C4	3002 F5	3029 C10	3049 C10	3068 B8	3121 C7	3140 A9	3196 F4	3245 D4	3280 D3	6032 C8	6112 D10	7013 D9	7046 D8	7251 C4
2001 E7	2027 D8	2110 D7	2129 F2	2241 C4	3003 E5	3030 B10	3050 C10	3069 B8	3122 B5	3141 A9	3197 F3	3246 D4	3281 D3	6033 C9	6113 A2	7014 D9	7047 C10	7252 C4
2002 F7	2028 D7	2111 C6	2130 F1	2242 C4	3004 F6	3031 D9	3051 C10	3070 B8	3123 B5	3142 A9	3198 F2	3247 D4	3282 D3	6034 C9	6114 A2	7015 D9	7048 D8	7253 C4
2003 F5	2029 D7	2112 C7	2131 F2	2243 C4	3005 F6	3032 D9	3052 C10	3071 B8	3124 C7	3143 A9	3199 F3	3248 D4	3283 D3	6035 C9	6115 A2	7016 D9	7049 D8	7254 C4
2004 E8	2030 C10	2113 B3	2132 F1	2244 C4	3006 F9	3033 D8	3053 C9	3072 B8	3125 B4	3144 A9	3200 F4	3249 D4	3284 D3	6036 D5	6116 A2	7017 D9	7050 D8	7255 C3
2005 E9	2031 B10	2114 B3	2133 F1	2245 C4	3007 F8	3034 D8	3054 C9	3073 B8	3126 B4	3145 A9	3201 F4	3250 D4	3285 D3	6037 B9	6117 A2	7018 D9	7051 D8	7256 D2
2006 F9	2032 B7	2115 B4	2134 F2	2246 D2	3008 E8	3035 D8	3055 D7	3074 B8	3127 B4	3146 A9	3202 F5	3251 D5	3286 D3	6038 B10	6118 A2	7019 D9	7052 D8	7257 E3
2007 F8	2033 C10	2116 B5	2135 F2	2247 D2	3009 F5	3036 D8	3056 B9	3075 B8	3128 A4	3147 A9	3203 F5	3252 D5	3287 D3	6039 B10	6119 A2	7020 D9	7053 D8	
2008 E6	2034 C10	2117 B5	2136 F2	2248 D2	3010 E10	3037 D8	3057 C8	3076 B8	3129 B4	3148 A9	3204 F5	3253 D5	3288 D3	6040 D7	6120 E5	7021 F9	7054 C9	
2009 E8	2035 D10	2118 B4	2137 B3	2249 E2	3011 D10	3038 D9	3058 C8	3077 B8	3130 B5	3149 A9	3205 F5	3254 A2	3289 D3	6041 D5	6121 E5	7022 F7	7055 D7	
2010 E7	2100 E5	2119 B3	2231 B2	2266 D5	3020 D5	3040 D9	3059 C8	3078 B8	3131 A5	3150 F2	3206 F5	3255 A2	3290 D3	6042 D5	6122 D4	7023 E8	7056 B7	

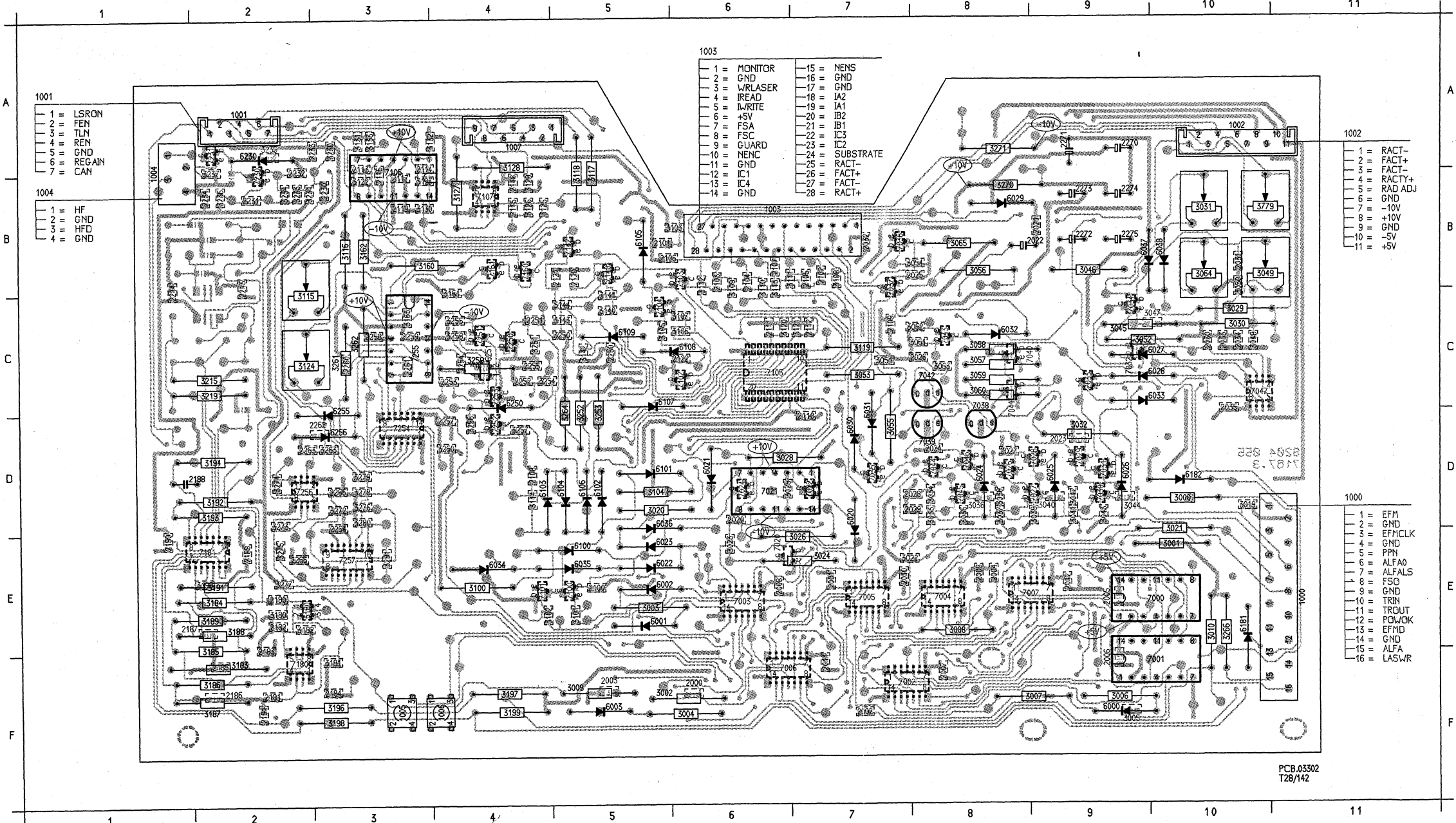

WOSP PANEL SOLDER SIDE

1000 E11	2011 F7	2101 B5	2120 B5	2232 B2	2270 A9	3021 E10	3041 D9	3060 C8	3113 C6	3132 A4	3188 E2	3237 B2	3272 D3	6024 D8	6104 D5	7005 E7	7038 C9	7142 B5
1001 A2	2012 E9	2102 B7	2121 B5	2233 A3	2271 A9	3022 E7	3042 D9	3061 C7	3114 D4	3133 A3	3189 E2	3238 D3	3273 D2	6025 D9	6105 B5	7006 F6	7039 C9	7143 B4
1002 A10	2020 D6	2103 C6	2122 C6	2234 B2	2272 B9	3023 E6	3043 D9	3062 C7	3115 C2	3134 C3	3190 E3	3239 D4	3274 D2	6026 D9	6106 D6	7007 E8	7040 C9	7144 B4
1003 B6	2021 B9	2104 C6	2123 C6	2235 C5	2273 B9	3024 E7	3044 D9	3063 C8	3116 B5	3135 A4	3191 E3	3240 D5	3275 E2	6027 C9	6107 C5	7020 E6	7041 D9	7180 F2
1004 B1	2022 B8	2105 B7	2124 F2	2236 C4	2274 B9	3025 E6	3045 D9	3064 C8	3117 B5	3136 C5	3192 D2	3241 D5	3276 D3	6028 C9	6108 C6	7021 D6	7042 C9	7181 E2
1005 F3	2023 D9	2106 B5	2125 F2	2237 C4	2275 B9	3026 E6	3046 B9	3065 B8	3118 B5	3137 C5	3193 D2	3242 C4	3277 E2	6029 B8	6109 C5	7022 D7	7043 C9	7230 B2
1006 F4	2024 D8	2107 B6	2126 F2	2238 C4	3000 D10	3027 D6	3047 C9	3066 B8	3119 C6	3138 C5	3194 D2	3243 C4	3278 D3	6030 D7	6110 F2	7023 D7	7044 D9	7231 A2
1007 A4	2025 B7	2108 D4	2127 F3	2239 C4	3001 E10	3028 C10	3048 B10	3067 B8	3120 C7	3139 B5	3195 F4	3244 C4	3279 D3	6031 D7	6111 D10	7024 D6	7045 D8	7250 C4
2000 F6	2026 C7	2109 C7	2128 F2	2240 C4	3002 F5	3029 C10	3049 B10	3068 B8	3121 C7	3140 C3	3196 F4	3245 C4	3280 D3	6032 C7	6112 D10	7025 D8	7046 D8	7251 C4
2001 E7	2027 D8	2110 D7	2129 F2	2241 C4	3003 F5	3030 C10	3050 B10	3069 B8	3122 B3	3141 C3	3197 F4	3246 C4	3281 E3	6033 C9	6230 A2	7026 D8	7047 C10	7252 D4
2002 F7	2028 D7	2111 C6	2130 F2	2242 D2	3004 F6	3031 B10	3051 C7	3070 B8	3123 B3	3142 C3	3198 F4	3247 C4	3282 B10	6034 F4	6231 C4	7027 D9	7048 C9	7253 A2
2003 F5	2029 D7	2112 C7	2131 D1	2243 C3	3005 F9	3032 D8	3052 C7	3071 B8	3124 C2	3143 C3	3199 F4	3248 C4	3283 E3	6035 C9	6232 C4	7028 D9	7049 C10	7254 C3
2004 E8	2030 C10	2113 B3	2132 B2	2244 C3	3006 F9	3033 D8	3053 C7	3072 B8	3125 B4	3144 C3	3200 A3	3249 C4	3284 B10	6036 D5	6233 C4	7029 D9	7050 C9	7255 C3
2005 E9	2031 B10	2114 B5	2133 F1	2245 C3	3007 F8	3034 D8	3054 B7	3073 B8	3126 B4	3145 F2	3201 A3	3250 C4	3285 E3	6037 B9	6234 C4	7030 D9	7051 F4	7256 C3
2006 F9	2032 B7	2115 B4	2134 F2	2246 D2	3008 E8	3035 D8	3055 D7	3074 B8	3127 A4	3146 F2	3202 A3	3251 C4	3286 E3	6038 B10	6235 C3	7031 D9	7102 C6	7257 F3
2007 F8	2033 C10	2116 B3	2213 C2	2247 D2	3009 F5	3037 D8	3056 B8	3075 B8	3128 A4	3147 E2	3203 B3	3252 C3	3287 E3	6039 D5	6236 D3	7032 C9	7103 B6	
2008 E6	2034 C10	2117 B3	2214 C1	2248 D3	3010 E10	3038 D8	3057 C8	3076 B8	3129 B4	3148 E2	3204 B2	3253 D5	3288 E3	6040 D7	6237 D5	7033 C8	7104 C9	
2009 E8	2035 D10	2118 B4	2220 B3	2249 E2	3019 D10	3039 D9	3058 C8	3077 B8	3130 C7	3149 E2	3205 B2	3254 D5	3289 E3	6041 D8	6238 F7	7034 C9	7105 C6	
2010 E7	2100 E5	2119 B3	2231 B2	2266 D3	3020 D5	3040 D9	3059 C8	3078 B8	3131 A3	3150 E2	3206 A2	3255 A2	3290 B8	6042 E5	6239 D5	7035 D7	7106 B3	
														6043 E5	6240 D4	7036 B7	7107 B4	
														6103 D4	7004 E8	7037 C7	7140 B5	

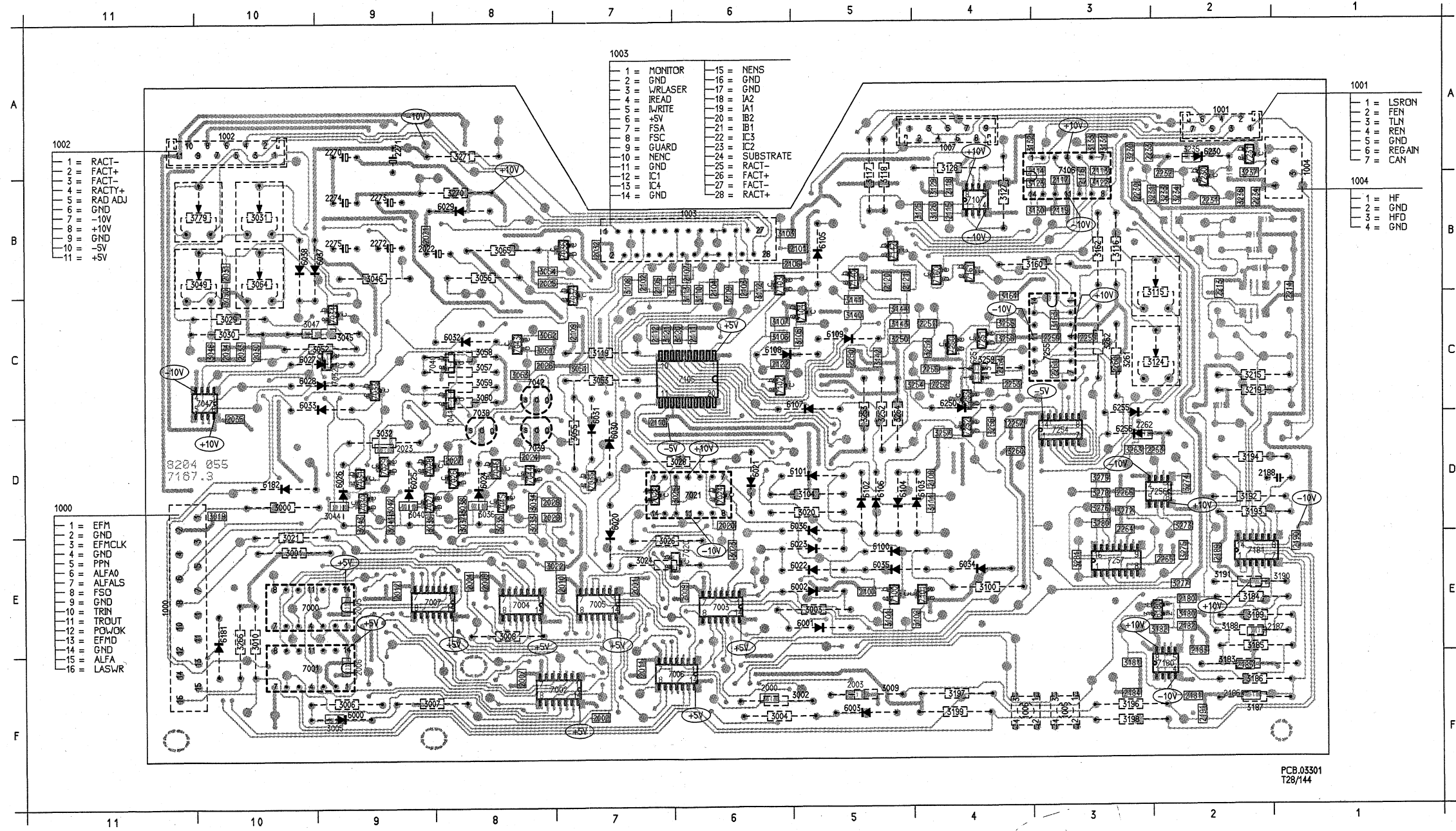

WOSP-2

- ALFA - Actual Absorption
- ALFA0 - Absorption Set
- ASEL - CA Current Select
- CALF - Central Aperture Low Frequency
- CALFN - Central Aperture Low Frequency Normalized
- CAN - Central Aperture Normalized
- FACT+ - Focus Actuator
- FEN - Focus Error Normalized
- FSA - Forward Sence Diode Anode
- FSO - Forward Sense Diode Reference Current
- HFSEL - Select CA Current For HF Reading Purposes
- IB1-2 - 3 Spot Push Pull Diode Current
- IC1-4 - 3 Spot Push Pull Diode Current
- IHF - CA Current To Remainder Part Of CA Processor
- IWREF - Monitor Current
- IWREF - Laser Writing Power Reference
- LSRON - Laser On
- NEN - Enable All Photodiode Currents To Normalizer
- NENC - Enable Central Photodiode Currents To Normalizer
- NENS - Enable Satellite Photodiode Currents To Normalizer
- PPN - Normalized Push Pull Signal
- RACT+ - Radial Actuator
- REGAIN - Radial Gain Current
- REN - Normalized Radial Error
- RINTON - Read Integrator On
- RINTRES - Read Integrator Reset
- RWLASER - Read/Non Write Laserpower
- TLN - Trackloss Normalized
- WINTON - Write Integrator On
- WINTRES - Write Integrator Reset
- WLINTON - Write Integrator On

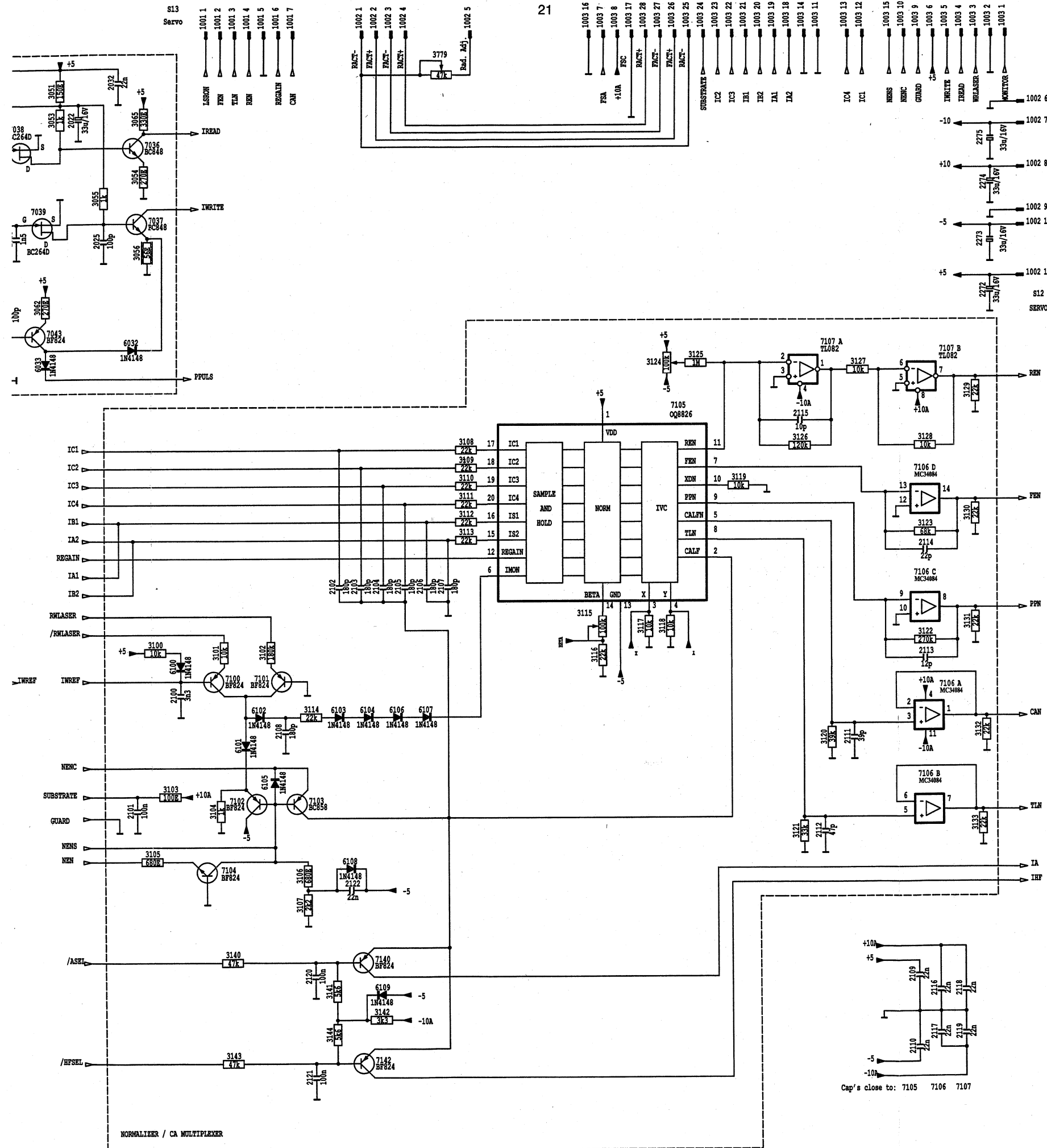

START UP PROCEDURE

38

CDR : flowchart start-up

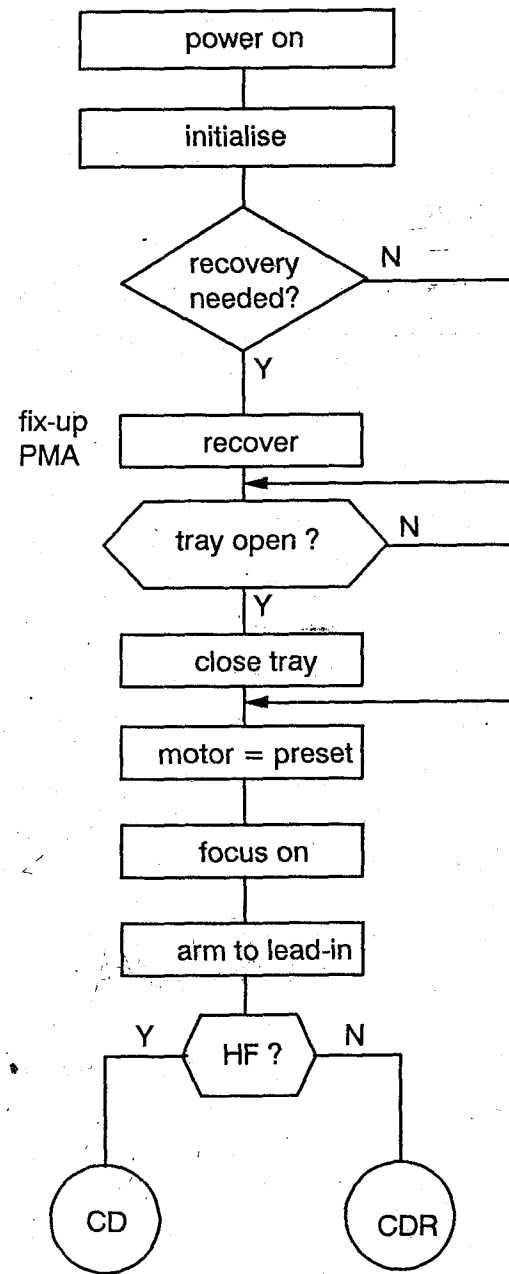

IN	OUT
AC MAINS	Supply Voltages KILL, KL, DRST OFF, RESET
RESET	SRST
	update PMA
TRIN, TROUT	TRMOT, LMOT TRIN
SRDAT, SRCMC	MCESSSEL, MOT MREADY
MCESSSEL, FOCON CAN, FEN	FACT, FOCOK
SLLS, SLIN	SLMOT, SLBS
HFSEL, IHF	EFMD

38

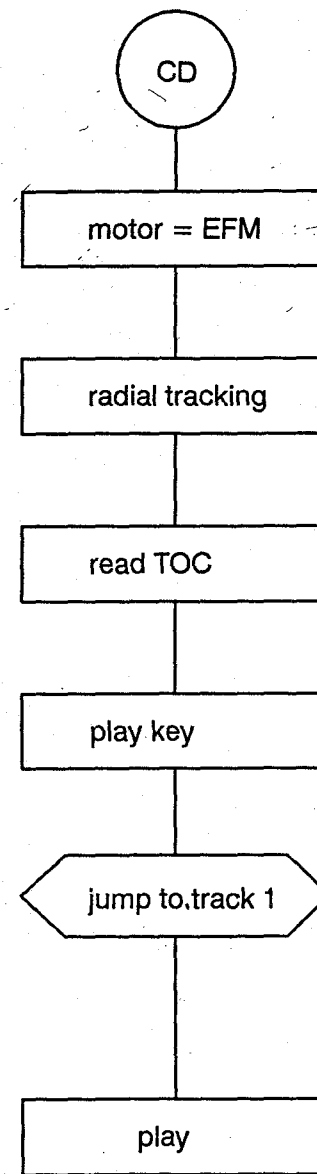

IN	OUT
MSEL, HF, MSC, MERR	MOT
REN, SLLS	RACT, SLMOT
HF, QCL, QRA	QDA
RJEN, RJV1-7, SLLS	SLMOT, RACT

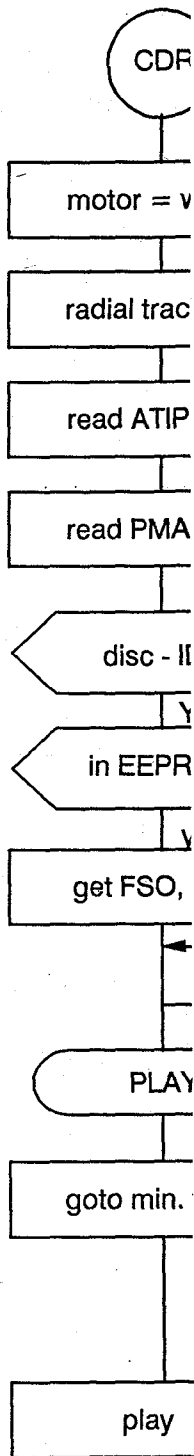

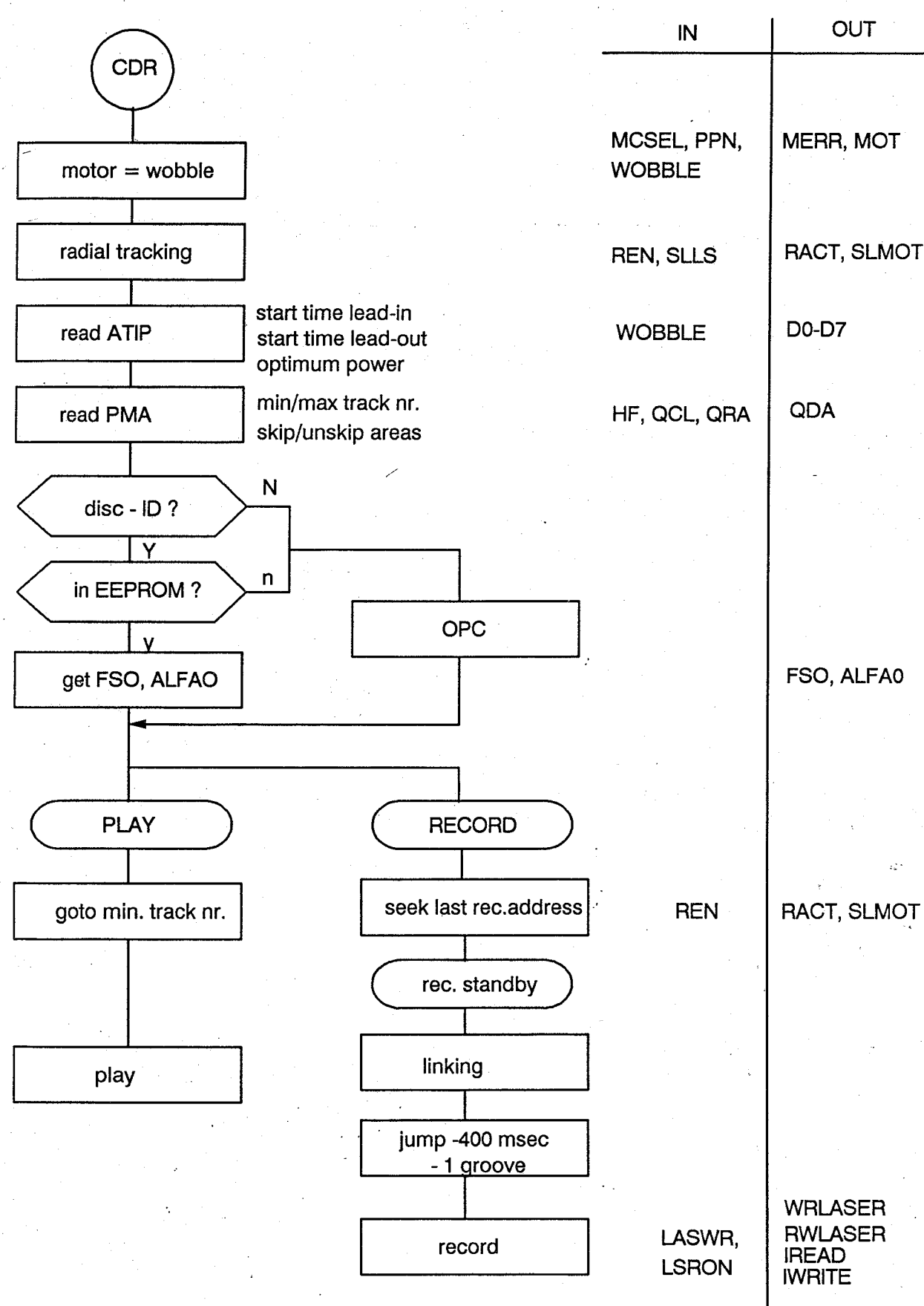
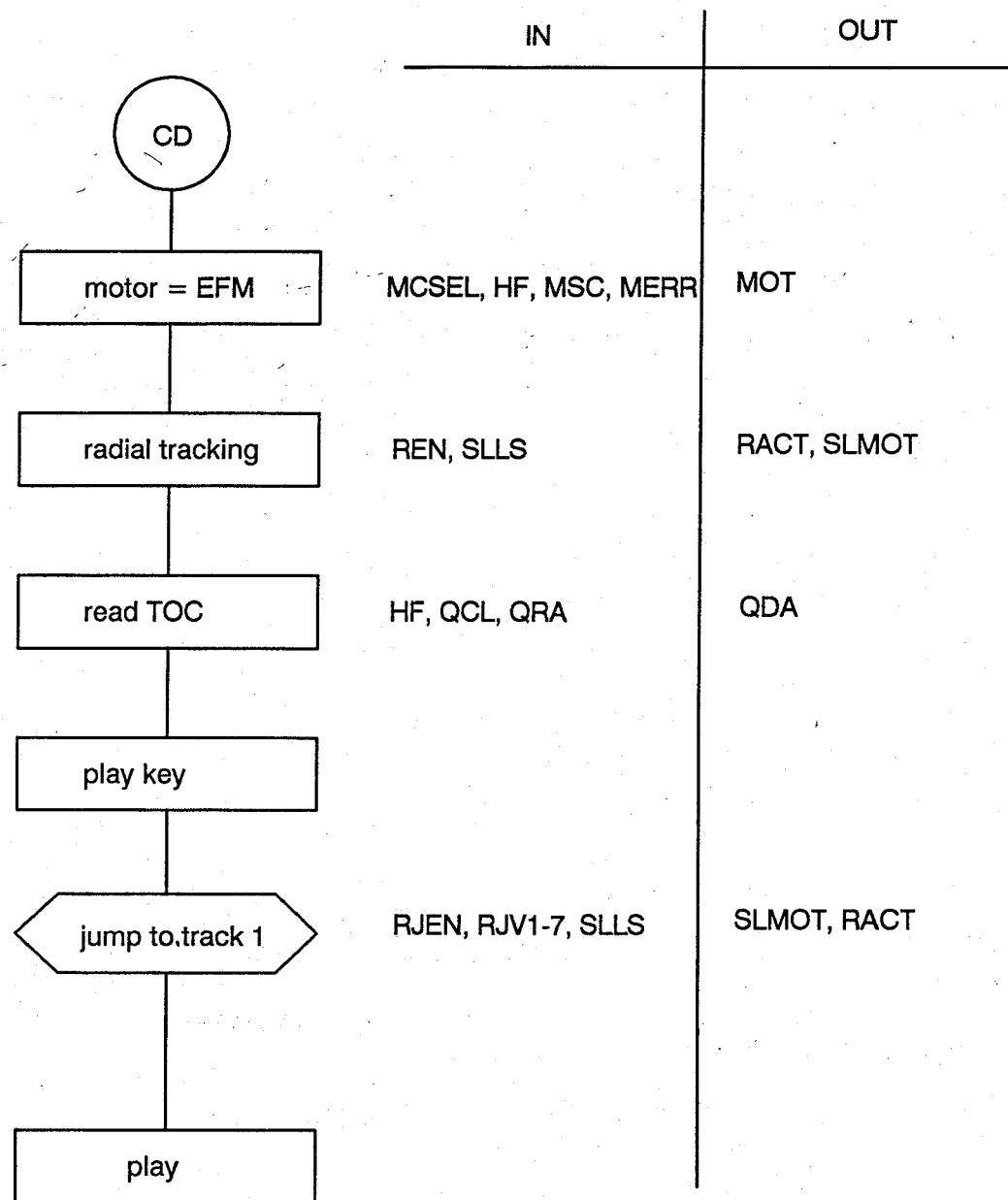

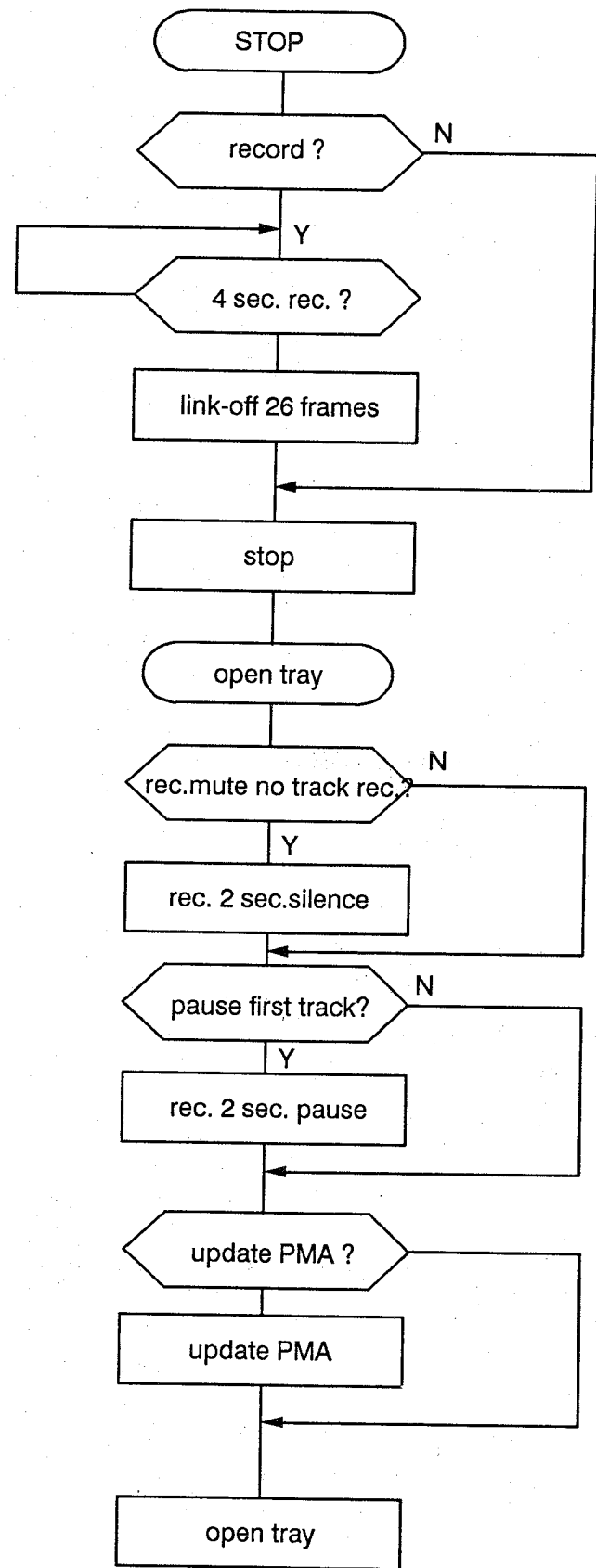

each step:
on error: try 5 X
then open tray
disc destroyed

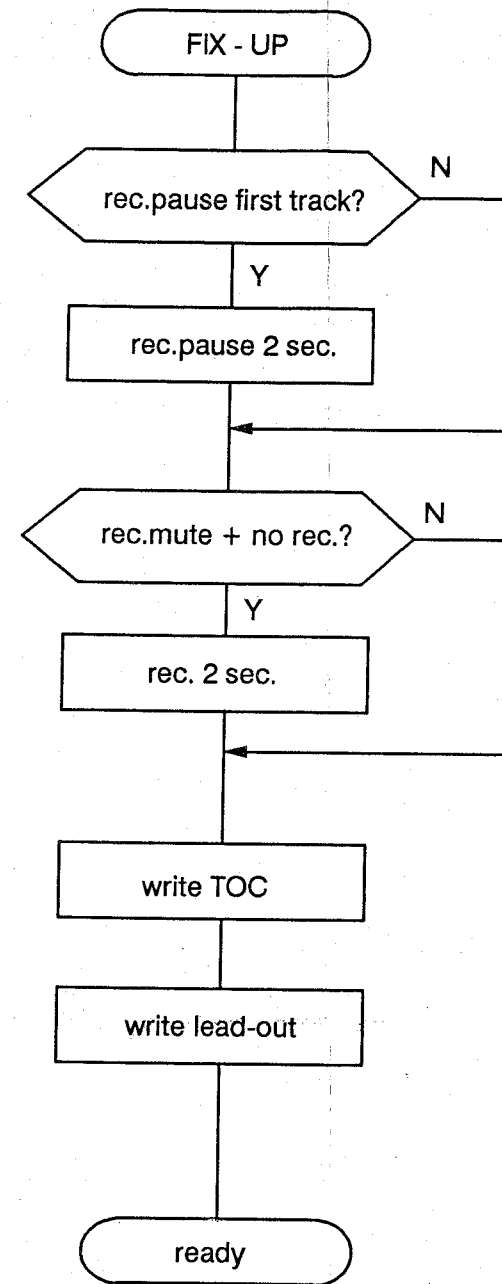

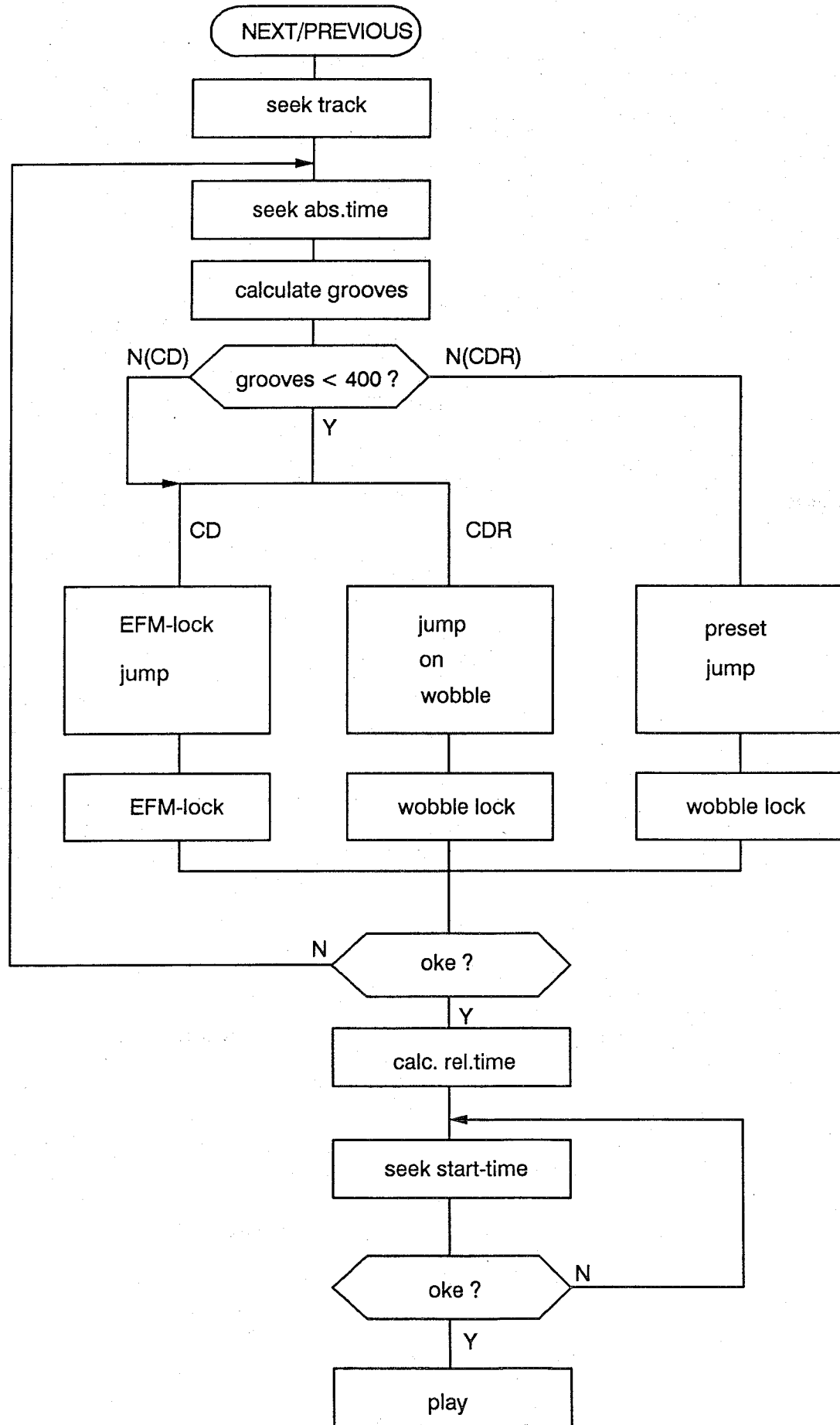

FAULTFINDING DIAGNOSIS

WOSP

-set upside down

Remove bottomplate

- Visual control: are all the solderings ok? (transistors, IC's)

- Check safety resistors

- Check all voltages (on connectors, IC's)

- Check actuator (ohmic)
on flex connector 1003 on WOSP
Radial actuator: points 25 - 28
Focus actuator : points 26 - 27

- Open the set

Remove the clasper

- Actuator is visible:
Press play: turntable motor turns
focus 2x pumping
laserlight
ok

- Actuator is inside:
Press play: turntable motor turns a few seconds
no focus
no laserlight
slide switch is not closed
(wiring or switch)

- Test of turntable motor:
(Black connector) External 1V on motor

- Test of slidemotor:
(Grey connector) External -1V: slide goes outwards
+1V: slide goes inwards

- Test of slidebeginswitch:
(Red connector) When slide is inside: 0Ω

INSTRUCTION TO REPLACE CDM-UNIT OR ENCODER PCB (ONLY FOR SOFTWARE FASE 1)

By replacing the CDM-unit and/or the Encoder PCB problems can occur with wrong OPC values or TOC tables. To prevent these problems, the EEPROM (IC 7481) has to be cleared. After replacing the CDM-unit and/or the Encoder PCB, this can be done as follows:

1. Power off.
2. Connect pin 2 (A16) to pin 16 (GND) of IC 7481 (situated on Encoder PCB coordinates F1) by means of e.g. miniature clips.
3. Power on.
4. Press 11 (two times one)
5. Press FIX UP
6. After ± 20 seconds, the display shows 01: the EEPROM has been cleared. If the display shows 00: the EEPROM is defective.
7. Power off.
8. Remove the connection.

EXPLODED VIEWS

CABINET

MECHANICAL PARTSLIST

131	4822 691 30273	MECH.UNIT CD-PL CDM CDR
132	4822 462 41397	FOOT
133	4822 466 40577	FELT
503	4822 444 60799	COVER
	4822 444 50674	REAR COVER
	4822 411 61674	SELECT KNOB
1001	4822 214 51931	SERVO PCB
1002	4822 214 51932	ENCODER PCB
1502	4822 276 11309	POWER SWITCH
	4822 146 31048	TRANSFORMER UNIT

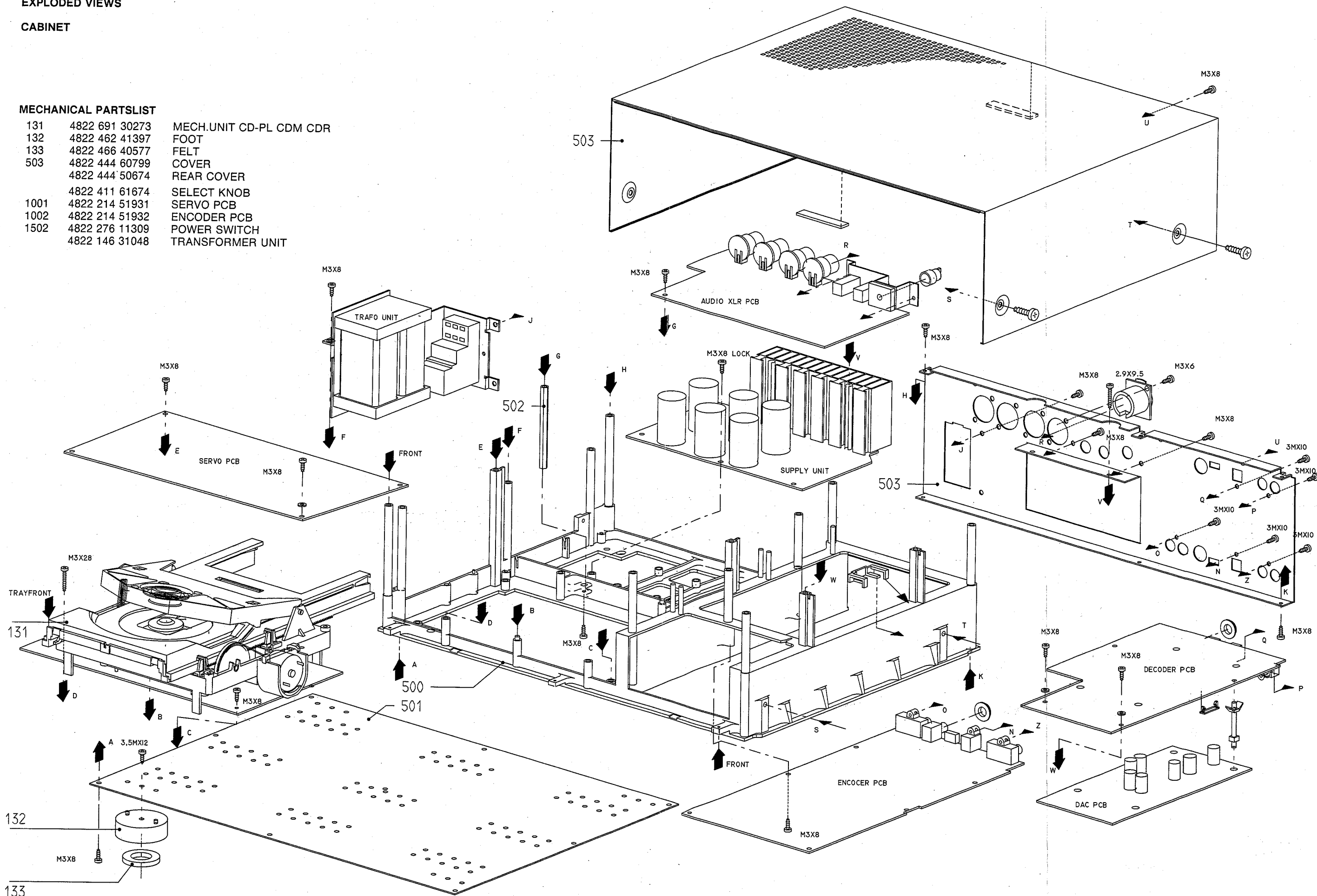

FRONT

MECHANICAL PARTSLIST

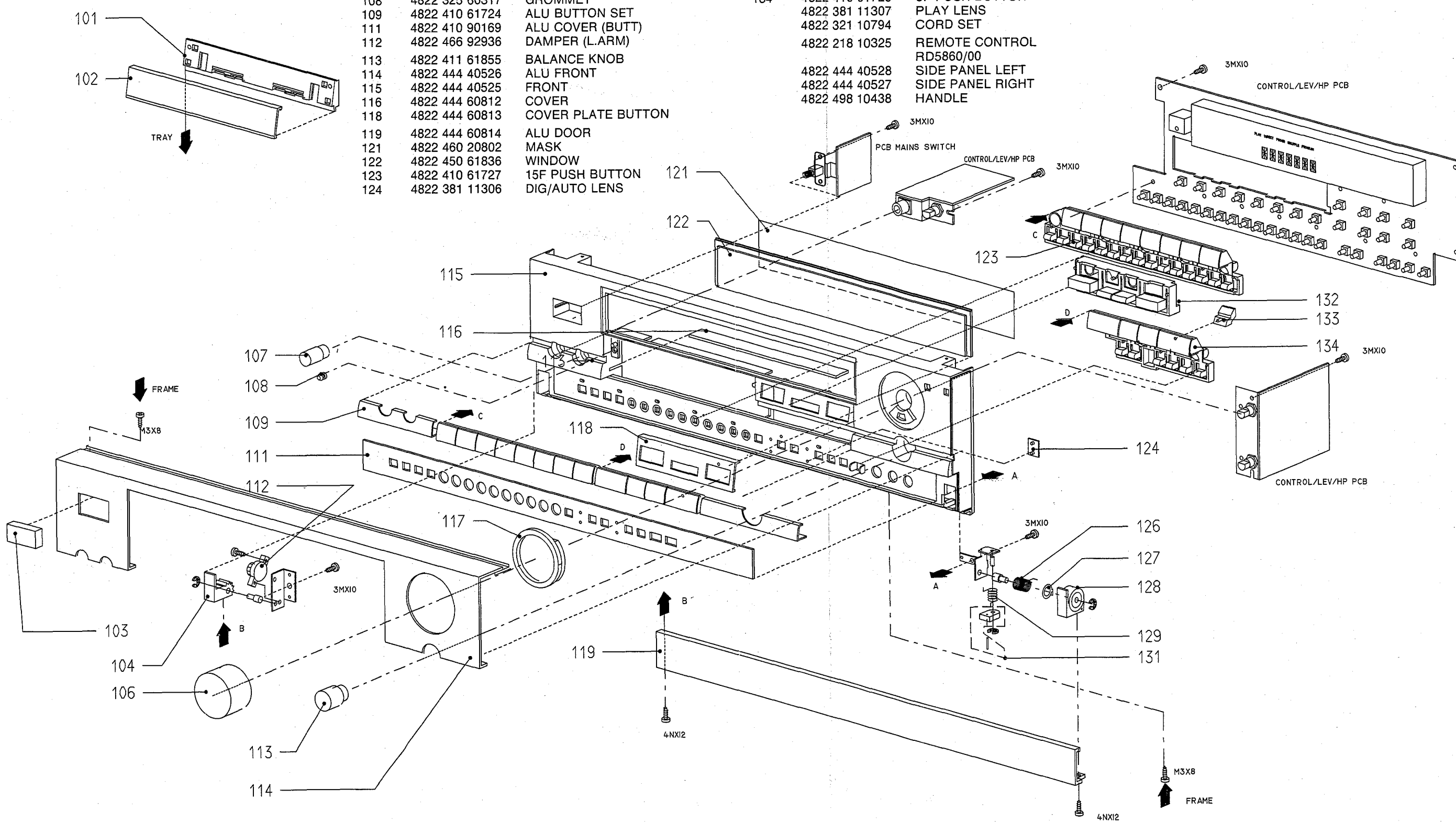

101	4822 444 40524	TRAY FRONT	126	4822 492 71042	SPRING (R. ARM)
102	4822 444 40523	ALU TRAY FRONT	127	4822 492 71043	LEAF SPRING (R. ARM)
103	4822 410 60358	POWER BUTTON	128	4822 402 61408	RIGHT ARM
104	4822 402 612407	LEFT ARM	129	4822 492 71041	SPRING (R. ARM)
106	4822 413 41699	REC LEVEL KNOB	131	4822 402 61409	MOVEMENT
107	4822 411 61856	PHONES VOLUME KNOB	132	4822 410 61726	4F PUSH BUTTON
108	4822 325 60317	GROMMET	133	4822 381 11305	RECORDING LENS
109	4822 410 61724	ALU BUTTON SET	134	4822 410 61725	6F PUSH BUTTON
111	4822 410 90169	ALU COVER (BUTT)		4822 381 11307	PLAY LENS
112	4822 466 92936	DAMPER (L.ARM)		4822 321 10794	CORD SET
113	4822 411 61855	BALANCE KNOB		4822 218 10325	REMOTE CONTROL RD5860/00
114	4822 444 40526	ALU FRONT		4822 444 40528	SIDE PANEL LEFT
115	4822 444 40525	FRONT		4822 444 40527	SIDE PANEL RIGHT
116	4822 444 60812	COVER		4822 498 10438	HANDLE
118	4822 444 60813	COVER PLATE BUTTON			
119	4822 444 60814	ALU DOOR			
121	4822 460 20802	MASK			
122	4822 450 61836	WINDOW			
123	4822 410 61727	15F PUSH BUTTON			
124	4822 381 11306	DIG/AUTO LENS			





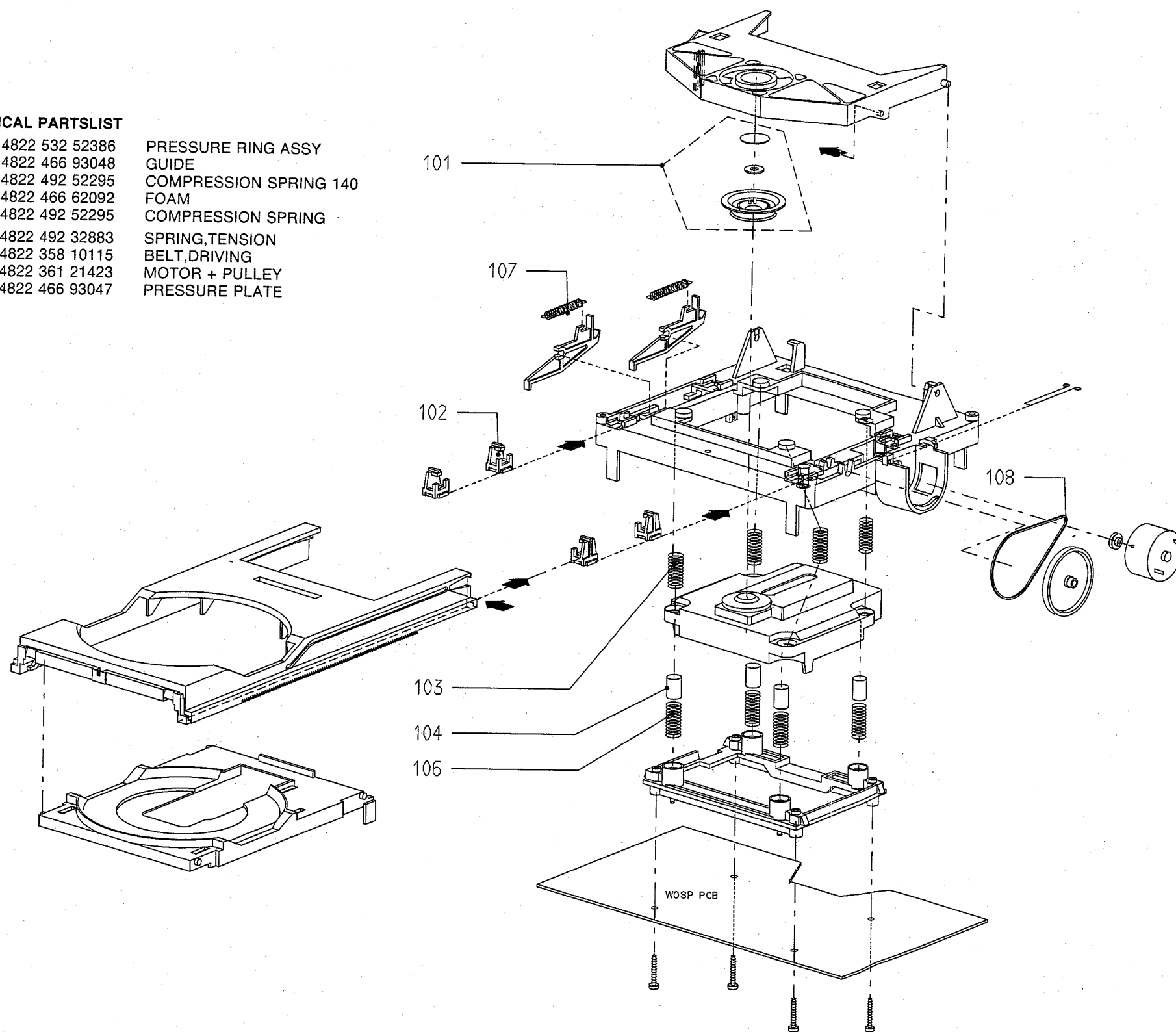

MECHANICAL PARTSLIST

101	4822 532 52386	PRESSURE RING ASSY
102	4822 466 93048	GUIDE
103	4822 492 52295	COMPRESSION SPRING 140
104	4822 466 62092	FOAM
106	4822 492 52295	COMPRESSION SPRING
107	4822 492 32883	SPRING,TENSION
108	4822 358 10115	BELT,DRIVING
	4822 361 21423	MOTOR + PULLEY
	4822 466 93047	PRESSURE PLATE



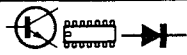

Miscellaneous					
1001	4822 214 51931	SERVO PCB	2681	5322 122 31863	330pF 5% 50V
Crystal			2682	4822 122 33809	22nF 20% 50V
1500	4822 242 73759	12MHz	2710	4822 122 33809	22nF 20% 50V
			2711	4822 122 33809	22nF 20% 50V
2500	5322 122 32658	22pF 5% 50V	2712	5322 122 32658	22pF 5% 50V
2501	5322 122 32658	22pF 5% 50V	2713	5322 122 32658	22pF 5% 50V
2502	5322 124 21643	22μF 20% 40V	2730	4822 122 33809	22nF 20% 50V
2503	4822 122 33809	22nF 20% 50V	2740	4822 122 31775	680pF 5% 50V
2521	4822 122 33175	2,2nF 20% 50V	2751	5322 121 42386	100nF 5% 63V
2522	4822 122 33809	22nF 20% 50V	2752	4822 121 43869	68nF 5% 50V
2523	4822 122 33809	22nF 20% 50V	2770	5322 121 42661	330nF 5% 63V
2524	5322 122 33809	22nF 20% 50V	2771	5322 122 32659	33pF 5% 50V
2525	4822 122 33809	22nF 20% 50V	2772	4822 122 33809	22nF 20% 50V
2526	5322 121 42661	330nF 5% 63V	2773	4822 122 33809	22nF 20% 50V
2527	4822 122 33809	22nF 20% 50V	2774	4822 122 33809	22nF 20% 50V
2528	4822 122 33809	22nF 20% 50V	2775	4822 122 33809	22nF 20% 50V
2540	4822 122 33809	22nF 20% 50V	2790	4822 122 33809	22nF 20% 50V
2541	4822 122 33496	100nF 10% 63V	2791	4822 122 33543	15nF 10% 50V
2542	4822 122 33543	15nF 10% 50V	2792	4822 122 33809	22nF 20% 50V
2543	4822 122 33496	100nF 10% 63V	2793	4822 122 33809	22nF 20% 50V
2560	4822 122 32891	68nF 10% 63V	2794	4822 122 33496	100nF 10% 63V
2561	4822 122 33891	3,3nF 10% 63V	2795	4822 121 43526	47nF 5% 100V
2562	5322 122 32531	100pF 5% 50V	2810	4822 122 33809	22nF 20% 50V
2563	4822 122 33177	10nF 20% 50V	2811	4822 122 33809	22nF 20% 50V
2564	4822 122 32575	220pF 10% 500V	2812	4822 122 33809	22nF 20% 50V
2565	4822 122 33809	22nF 20% 50V	2814	4822 122 33809	22nF 20% 50V
2566	4822 122 33809	22nF 20% 50V	2830	4822 124 40272	33μF 20% 16V
2567	4822 122 32542	47nF 10% 63V	2850	4822 122 33342	33nF 10% 50V
2568	5322 122 32531	100pF 5% 50V	2851	5322 121 42661	330nF 5% 63V
2580	4822 122 33809	22nF 20% 50V	2852	4822 122 33809	22nF 20% 50V
2581	4822 122 33809	22nF 20% 50V	2853	4822 122 33809	22nF 20% 50V
2582	5322 122 34123	1nF 10% 50V	2854	4822 122 33496	100nF 10% 63V
2583	4822 122 33809	22nF 20% 50V	2870	4822 122 33809	22nF 20% 50V
2584	4822 122 33809	22nF 20% 50V	2871	4822 122 33809	22nF 20% 50V
2600	4822 122 33809	22nF 20% 50V	2872	5322 122 32531	100pF 5% 50V
2601	4822 122 33809	22nF 20% 50V	2873	4822 122 32542	47nF 10% 63V
2602	5322 122 32531	100pF 5% 50V	2874	4822 122 32575	220pF 10% 500V
2603	4822 122 33496	100nF 10% 63V			
2604	4822 121 41854	150nF 5% 63V	3500	4822 050 21002	1k 1% 0,6W
2605	4822 122 33175	2,2nF 20% 50V	3501	4822 050 21002	1k 1% 0,6W
2606	4822 122 33496	100nF 10% 63V	3502	4822 052 10108	1Ω 5% 0,33W
2620	5322 124 21643	22μF 20% 40V	3503	4822 050 21003	10k 1% 0,6W
2630	4822 121 51252	470nF 5% 63V	3504	4822 050 21003	10k 1% 0,6W
2640	4822 121 43901	4,7nF 5% 50V	3506	4822 050 21003	10k 1% 0,6W
2641	4822 121 43867	22nF 5% 50V	3507	4822 050 21003	10k 1% 0,6W
2642	5322 122 32448	10pF 5% 50V	3508	4822 050 21003	10k 1% 0,6W
2645	4822 122 33496	100nF 10% 63V	3509	4822 050 21003	10k 1% 0,6W
2650	4822 122 33177	10nF 20% 50V	3510	4822 050 22203	22k 1% 0,6W
2651	4822 122 33809	22nF 20% 50V	3511	4822 050 22203	22k 1% 0,6W
2652	4822 122 33809	22nF 20% 50V	3512	4822 050 22203	22k 1% 0,6W
2653	4822 122 33496	100nF 10% 63V	3513	4822 050 21002	1k 1% 0,6W
2654	4822 122 33496	100nF 10% 63V	3514	4822 051 10101	100Ω 2% 0,25W
2660	4822 124 40272	33μF 20% 16V	3515	4822 050 21003	10k 1% 0,6W
2661	4822 122 33809	22nF 20% 50V	3516	4822 050 21003	10k 1% 0,6W
2662	4822 124 40272	33μF 20% 16V	3517	4822 050 21003	10k 1% 0,6W
2663	4822 122 33809	22nF 20% 50V	3518	4822 050 21003	10k 1% 0,6W
2664	4822 124 41596	22μF 20% 50V	3519	4822 050 21003	10k 1% 0,6W
2665	4822 122 33809	22nF 20% 50V	3520	4822 050 28203	82k 1% 0,6W
2666	4822 124 41596	22μF 20% 50V	3521	4822 116 52235	1M 5% 0,5W
2667	4822 122 33809	22nF 20% 50V	3522	4822 050 25604	560k 1% 0,6W
2669	5322 124 21643	22μF 20% 40V	3523	4822 050 21804	180k 1% 0,6W
2671	5322 124 21643	22μF 20% 40V	3524	4822 116 52235	1M 5% 0,5W
2680	5322 122 31863	330pF 5% 50V	3525	4822 050 22704	270k 1% 0,6W
			3526	4822 051 20274	270k 5% 0,1W
			3527	4822 116 52272	330k 5% 0,5W

					
3528	4822 050 21204	120k 1% 0,6W	3632	4822 050 26804	680k 1% 0,6W
3529	4822 050 24703	47k 1% 0,6W	3640	4822 050 28203	82k 1% 0,6W
3530	4822 051 20105	1M 5% 0,1W	3641	4822 050 13303	33k 1% 0,4W
3531	4822 116 52244	15k 5% 0,5W	3642	4822 116 52235	1M 5% 0,5W
3532	4822 051 20473	47k 5% 0,1W	3643	4822 050 25603	56k 1% 0,6W
3533	4822 050 25603	56k 1% 0,6W	3644	4822 116 52264	27k 5% 0,5W
3534	4822 051 20473	47k 5% 0,1W	3645	4822 116 52234	100k 5% 0,5W
3535	4822 051 20682	6k8 5% 0,1W	3646	4822 050 24704	470k 1% 0,6W
3542	4822 116 52234	100k 5% 0,5W	3647	4822 116 52234	100k 5% 0,5W
3545	4822 050 22003	20k 1% 0,6W	3648	4822 116 52264	27k 5% 0,5W
3546	4822 116 52264	27k 5% 0,5W	3649	4822 052 10229	22Ω 5% 0,33W
3547	4822 050 24704	470k 1% 0,6W	3650	4822 050 23902	3k9 1% 0,6W
3550	4822 116 52235	1M 5% 0,5W	3651	4822 050 21203	12k 1% 0,6W
3551	4822 050 21003	10k 1% 0,6W	3652	4822 050 21203	12k 1% 0,6W
3552	4822 050 13303	33k 1% 0,4W	3653	4822 052 10108	1Ω 5% 0,33W
3560	4822 050 13303	33k 1% 0,4W	3654	4822 050 21203	12k 1% 0,6W
3561	4822 050 22204	220k 1% 0,6W	3655	4822 050 21203	12k 1% 0,6W
3562	4822 050 25603	56k 1% 0,6W	3656	4822 052 10108	1Ω 5% 0,33W
3563	4822 050 22204	220k 1% 0,6W	3657	4822 052 10229	22Ω 5% 0,33W
3564	4822 050 13303	33k 1% 0,4W	3680	4822 050 21003	10k 1% 0,6W
3565	4822 050 25603	56k 1% 0,6W	3681	4822 050 22204	220k 1% 0,6W
3566	4822 050 22203	22k 1% 0,6W	3682	4822 050 21002	1k 1% 0,6W
3567	4822 050 13303	33k 1% 0,4W	3683	4822 050 21002	1k 1% 0,6W
3568	4822 050 23902	3k9 1% 0,6W	3684	4822 116 52244	15k 5% 0,5W
3569	4822 050 23902	3k9 1% 0,6W	3685	4822 050 28203	82k 1% 0,6W
3570	4822 050 26803	68k 1% 0,6W	3686	4822 050 28203	82k 1% 0,6W
3571	4822 050 24703	47k 1% 0,6W	3687	4822 116 52244	15k 5% 0,5W
3572	4822 050 21504	150k 1% 0,6W	3688	4822 050 21002	1k 1% 0,6W
3573	4822 050 21804	180k 1% 0,6W	3689	4822 050 21002	1k 1% 0,6W
3574	4822 116 52264	27k 5% 0,5W	3690	4822 050 21003	10k 1% 0,6W
3575	4822 050 22203	22k 1% 0,6W	3691	4822 050 21003	10k 1% 0,6W
3576	4822 050 22203	22k 1% 0,6W	3692	4822 050 21002	1k 1% 0,6W
3577	4822 050 21204	120k 1% 0,6W	3693	4822 050 22203	22k 1% 0,6W
3578	4822 050 21504	150k 1% 0,6W	3694	4822 050 22203	22k 1% 0,6W
3580	4822 050 13303	33k 1% 0,4W	3695	4822 050 22203	22k 1% 0,6W
3581	4822 050 24703	47k 1% 0,6W	3696	4822 050 26803	68k 1% 0,6W
3582	4822 116 52235	1M 5% 0,5W	3697	4822 050 21002	1k 1% 0,6W
3583	4822 116 52224	470Ω 5% 0,5W	3710	4822 050 21002	1k 1% 0,6W
3584	4822 052 10108	1Ω 5% 0,33W	3711	4822 050 22204	220k 1% 0,6W
3585	4822 052 10108	1Ω 5% 0,33W	3712	4822 050 21003	10k 1% 0,6W
3586	4822 050 21003	10k 1% 0,6W	3713	4822 050 21002	1k 1% 0,6W
3600	4822 050 22203	22k 1% 0,6W	3715	4822 050 21003	10k 1% 0,6W
3601	4822 050 21003	10k 1% 0,6W	3740	4822 050 24304	430k 5% 0,125W
3602	4822 050 22203	22k 1% 0,6W	3741	4822 050 23903	39k 5% 0,125W
3603	4822 050 22704	270k 1% 0,6W	3742	4822 050 21203	12k 1% 0,6W
3604	4822 050 21003	10k 1% 0,6W	3743	4822 116 52244	15k 5% 0,5W
3605	4822 050 22203	22k 1% 0,6W	3744	4822 050 15602	5k6 1% 0,4W
3606	4822 050 21003	10k 1% 0,6W	3745	4822 050 15602	5k6 1% 0,4W
3607	4822 050 24702	4k7 1% 0,6W	3750	4822 050 22704	270k 1% 0,6W
3608	4822 050 22203	22k 1% 0,6W	3751	4822 116 52224	470Ω 5% 0,5W
3609	4822 050 26803	68k 1% 0,6W	3752	4822 050 21204	120k 5% 0,125W
3610	4822 050 22204	220k 1% 0,6W	3753	4822 050 21203	12k 5% 0,125W
3611	4822 116 52234	100k 5% 0,5W	3754	4822 050 22704	270k 5% 0,125W
3612	4822 050 13303	33k 1% 0,4W	3755	4822 050 21002	1k 1% 0,6W
3614	4822 050 21203	12k 1% 0,6W	3756		

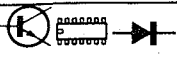
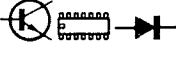

						
3791	4822 050 15602	5k6 1% 0,4W		4011	4822 051 10008	Chip jumper
3792	4822 050 21002	1k 1% 0,6W		4012	4822 051 10008	Chip jumper
3793	4822 050 13303	33k 1% 0,4W		4013	4822 051 10008	Chip jumper
3794	4822 050 13303	33k 1% 0,4W		4014	4822 051 10008	Chip jumper
3795	4822 050 21003	10k 1% 0,6W		4015	4822 051 10008	Chip jumper
3796	4822 116 52234	100k 5% 0,5W		4016	4822 051 10008	Chip jumper
3797	4822 116 52272	330k 5% 0,5W		4017	4822 051 10008	Chip jumper
3799	4822 116 52235	1M 5% 0,5W		4018	4822 051 10008	Chip jumper
3800	4822 116 52235	1M 5% 0,5W		4019	4822 051 10008	Chip jumper
3801	4822 116 52272	330k 5% 0,5W		4020	4822 051 10008	Chip jumper
3810	4822 050 21003	10k 1% 0,6W		4021	4822 051 10008	Chip jumper
3811	4822 050 21003	10k 1% 0,6W		4022	4822 051 10008	Chip jumper
3813	4822 050 21804	180k 1% 0,6W		4023	4822 051 10008	Chip jumper
3814	4822 050 21804	180k 1% 0,6W		4024	4822 051 10008	Chip jumper
3830	4822 116 52234	100k 5% 0,5W		4025	4822 051 10008	Chip jumper
3831	4822 050 28203	82k 1% 0,6W		4026	4822 051 10008	Chip jumper
3832	4822 050 21002	1k 1% 0,6W		4027	4822 051 10008	Chip jumper
3833	4822 116 52234	100k 5% 0,5W		4028	4822 051 10008	Chip jumper
3834	4822 050 22202	2k2 1% 0,6W		4029	4822 051 10008	Chip jumper
3835	4822 050 24703	47k 1% 0,6W		4030	4822 051 10008	Chip jumper
3836	4822 050 24703	47k 1% 0,6W		4031	4822 051 10008	Chip jumper
3837	4822 050 24703	47k 1% 0,6W		4032	4822 051 10008	Chip jumper
3838	4822 050 24703	47k 1% 0,6W		4033	4822 051 10008	Chip jumper
3850	4822 116 52244	15k 5% 0,5W		4034	4822 051 10008	Chip jumper
3851	4822 116 52234	100k 5% 0,5W		4035	4822 051 10008	Chip jumper
3852	4822 050 15602	5k6 1% 0,4W		4036	4822 051 10008	Chip jumper
3853	4822 116 52272	330k 5% 0,5W		4037	4822 051 10008	Chip jumper
3854	4822 050 21002	1k 1% 0,6W		4038	4822 051 10008	Chip jumper
3855	4822 050 21003	10k 1% 0,6W		4039	4822 051 10008	Chip jumper
3856	4822 050 21003	10k 1% 0,6W		4040	4822 051 10008	Chip jumper
3857	4822 050 24703	47k 1% 0,6W		4041	4822 051 10008	Chip jumper
3858	4822 050 21203	12k 1% 0,6W		4042	4822 051 10008	Chip jumper
3859	4822 050 21003	10k 1% 0,6W		4043	4822 051 10008	Chip jumper
3860	4822 050 21003	10k 1% 0,6W		4044	4822 051 10008	Chip jumper
3861	4822 050 24703	47k 1% 0,6W		4045	4822 051 10008	Chip jumper
3862	4822 050 21203	12k 1% 0,6W		4046	4822 051 10008	Chip jumper
3863	4822 050 24703	47k 1% 0,6W		4047	4822 051 10008	Chip jumper
3864	4822 052 10229	22Ω 5% 0,33W		4049	4822 051 10008	Chip jumper
3865	4822 052 10108	1Ω 5% 0,33W		4050	4822 051 10008	Chip jumper
3866	4822 052 10108	1Ω 5% 0,33W		4051	4822 051 10008	Chip jumper
3867	4822 050 22203	22k 1% 0,6W		4052	4822 051 10008	Chip jumper
3871	4822 116 52264	27k 5% 0,5W		4053	4822 051 10008	Chip jumper
3872	4822 050 26803	68k 1% 0,6W		4054	4822 051 10008	Chip jumper
3873	4822 116 52234	100k 5% 0,5W		4055	4822 051 10008	Chip jumper
3874	4822 050 22704	270k 1% 0,6W				
3875	4822 050 22203	22k 1% 0,6W				
3876	4822 050 21002	1k 1% 0,6W				
3877	4822 050 21002	1k 1% 0,6W				
3880	4822 050 24703	47k 1% 0,6W				
3881	4822 050 22203	22k 1% 0,6W				
3882	4822 116 52272	330k 5% 0,5W				
3883	4822 050 24703	47k 1% 0,6W				
3884	4822 050 22704	270k 1% 0,6W				
3885	4822 050 24703	47k 1% 0,6W				
3886	4822 050 21504	150k 1% 0,6W				
4001	4822 051 10008	Chip jumper				
4002	4822 051 10008	Chip jumper				
4003	4822 051 10008	Chip jumper				
4004	4822 051 10008	Chip jumper				
4005	4822 051 10008	Chip jumper				
4006	4822 051 10008	Chip jumper				
4007	4822 051 10008	Chip jumper				
4008	4822 051 10008	Chip jumper				
4009	4822 051 10008	Chip jumper				
4010	4822 051 10008	Chip jumper				
						
				6530	4822 130 30621	1N4148
				6531	4822 130 30621	1N4148
				6540	4822 130 30621	1N4148
				6561	4822 130 30621	1N4148
				6562	4822 130 30621	1N4148
				6563	4822 130 30621	1N4148
				6580	4822 130 30861	BZX79-C7V5
				6581	4822 130 30861	BZX79-C7V5
				6600	4822 130 30621	1N4148
				6601	4822 130 30621	1N4148
				6602	4822 130 30621	1N4148
				6603	4822 130 30621	1N4148
				6604	4822 130 30621	1N4148
				6605	4822 130 30621	1N4148
				6606	5322 130 34563	BZX79-C2V7
				6680	4822 130 30621	1N4148
				6681	4822 130 30621	1N4148
				6740	4822 130 34174	BZX79-C4V7
				6741	4822 130 34174	BZX79-C4V7
				6750	4822 130 34174	BZX79-C4V7

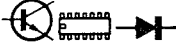

					
6751	4822 130 34174	BZX79-C4V7	7641	5322 130 44656	BC264D
6790	4822 130 30621	1N4148	7642	4822 209 72587	TCA0372DP2
6791	4822 130 30621	1N4148	7680	4822 209 30732	LM319D
6792	4822 130 30621	1N4148	7681	4822 130 61207	BC848
6830	4822 130 30621	1N4148	7682	5322 130 42012	BC858
6831	4822 130 30621	1N4148	7683	4822 130 61207	BC848
6832	4822 130 30621	1N4148	7684	5322 130 42012	BC858
6833	4822 130 30621	1N4148	7685	4822 130 61207	BC848
6850	4822 130 34174	BZX79-C4V7	7711	4822 130 61207	BC848
6851	4822 130 34174	BZX79-C4V7	7712	4822 130 61207	BC848
6870	4822 130 31981	BZX79-C3V9	7713	4822 209 30739	MC74HC04AD
6871	4822 130 31981	BZX79-C3V9	7730	4822 209 30734	MC74HC4053N
6872	4822 130 31981	BZX79-C3V9	7731	5322 209 73011	PC74HC4520P
6873	4822 130 31981	BZX79-C3V9	7740	4822 209 30734	MC74HC4053N
6874	4822 130 30621	1N4148	7741	4822 209 30738	TL084CN
7500	4822 209 30737	SC87C51CCN40	7750	4822 209 30734	MC74HC4053N
7501	4822 209 30731	MC74HC03AD	7770	4822 130 61207	BC848
7520	4822 209 30725	MC34002BD	7771	5322 130 42012	BC858
7521	5322 209 82941	LM358D	7772	4822 130 40995	BD438
7522	4822 209 30734	MC74HC4053N	7773	4822 130 40982	BD437
7540	4822 209 30733	MC74HC164N	7790	4822 209 30733	MC74HC164N
7541	4822 209 30725	MC34002BD	7791	4822 209 30738	TL084CN
7542	5322 130 44656	BC264D	7792	5322 130 42012	BC858
7560	4822 209 30734	MC74HC4053N	7810	4822 209 30739	MC74HC04AD
7561	4822 130 61207	BC848	7811	4822 209 30734	MC74HC4053N
7562	5322 130 42012	BC858	7830	4822 209 70941	MC34084P
7563	5322 209 70225	LM393D	7850	5322 130 42012	BC858
7580	5322 130 44656	BC264D	7851	5322 130 42012	BC858
7581	5322 130 44647	BC368	7852	4822 209 72587	TCA0372DP2
7582	5322 130 44593	BC369	7870	5322 209 70225	LM393D
7600	5322 130 42012	BC858	7871	4822 209 30734	MC74HC4053N
7601	4822 209 30725	MC34002BD	7880	5322 130 42012	BC858
7602	4822 130 61207	BC848	7881	4822 130 61207	BC848
7630	4822 130 61207	BC848			
7640	5322 130 44656	BC264D			

3029	4822 050 22203	22k 1% 0,6W	3440	4822 051 20473	47k 5% 0,1W
3300	4822 051 20104	100k 5% 0,1W	3441	4822 051 20103	10k 5% 0,1W
3301	4822 051 20104	100k 5% 0,1W	3442	4822 051 20223	22k 5% 0,1W
3302	4822 051 20104	100k 5% 0,1W	3443	4822 052 10478	4 Ω 7 5% 0,33W
3303	4822 051 20104	100k 5% 0,1W	3444	4822 051 20223	22k 5% 0,1W
3304	4822 050 21002	1k 1% 0,6W	3445	4822 051 20223	22k 5% 0,1W
3305	4822 050 21002	1k 1% 0,6W	3446	4822 051 20473	47k 5% 0,1W
3306	4822 050 21002	1k 1% 0,6W	3447	4822 051 20473	47k 5% 0,1W
3307	4822 050 21002	1k 1% 0,6W	3448	4822 051 20103	10k 5% 0,1W
3308	4822 052 10339	33 Ω 5% 0,33W	3449	4822 051 20101	100 Ω 5% 0,1W
3309	4822 052 10339	33 Ω 5% 0,33W	3450	4822 050 22403	24k 1% 0,6W
3340	4822 052 10478	4 Ω 7 5% 0,33W	3451	4822 050 24302	4k3 1% 0,6W
3341	4822 052 10478	4 Ω 7 5% 0,33W	3452	4822 050 21304	130k 1% 0,6W
3342	4822 052 10478	4 Ω 7 5% 0,33W	3453	4822 052 10339	33 Ω 5% 0,33W
3343	4822 051 20479	47 Ω 5% 0,1W	3454	4822 052 10339	33 Ω 5% 0,33W
3344	4822 051 20479	47 Ω 5% 0,1W	3455	4822 050 22403	24k 1% 0,6W
3345	4822 052 10478	4 Ω 7 5% 0,33W	3456	4822 050 24302	4k3 1% 0,6W
3346	4822 051 20223	22k 5% 0,1W	3457	4822 050 21304	130k 1% 0,6W
3347	4822 051 20223	22k 5% 0,1W	3458	4822 050 21002	1k 1% 0,6W
3348	4822 051 20472	4k7 5% 0,1W	3459	4822 051 20822	8k2 5% 0,1W
3349	4822 052 10478	4 Ω 7 5% 0,33W	3460	4822 051 20105	1M 5% 0,1W
3350	4822 052 10478	4 Ω 7 5% 0,33W	3461	4822 051 20222	2k2 5% 0,1W
3351	4822 051 20479	47 Ω 5% 0,1W	3462	4822 052 10108	1 Ω 5% 0,33W
3352	4822 051 20479	47 Ω 5% 0,1W	3463	4822 051 20222	2k2 5% 0,1W
3354	4822 052 10478	4 Ω 7 5% 0,33W	3464	4822 051 20103	10k 5% 0,1W
3370	4822 052 10478	4 Ω 7 5% 0,33W	3480	4822 052 10108	1 Ω 5% 0,33W
3371	4822 052 10478	4 Ω 7 5% 0,33W	3481	4822 051 20824	820k 5% 0,1W
3372	4822 050 21003	10k 1% 0,6W	3482	4822 051 20103	10k 5% 0,1W
3373	4822 050 21003	10k 1% 0,6W	3484	4822 050 21002	1k 1% 0,6W
3374	4822 050 21003	10k 1% 0,6W	3485	4822 051 20223	22k 5% 0,1W
3377	4822 052 10478	4 Ω 7 5% 0,33W	3486	4822 050 22203	22k 1% 0,6W
3378	4822 052 10108	1 Ω 5% 0,33W	3487	4822 050 22203	22k 1% 0,6W
3379	4822 051 20391	390 Ω 5% 0,1W	3488	4822 050 22203	22k 1% 0,6W
3380	4822 051 20121	120 Ω 5% 0,1W	3489	4822 052 10478	4 Ω 7 5% 0,33W
3381	4822 050 21003	10k 1% 0,6W	3490	4822 051 20223	22k 5% 0,1W
3382	4822 051 20274	270k 5% 0,1W	3491	4822 051 20101	100 Ω 5% 0,1W
3383	4822 051 20274	270k 5% 0,1W	3492	4822 051 20101	100 Ω 5% 0,1W
3385	4822 051 20101	100 Ω 5% 0,1W	3493	4822 051 10102	1k 2% 0,25W
3386	4822 051 20101	100 Ω 5% 0,1W	3494	4822 051 10101	100 Ω 2% 0,25W
3387	4822 052 10478	4 Ω 7 5% 0,33W	3495	4822 050 22203	22k 1% 0,6W
3400	4822 052 10478	4 Ω 7 5% 0,33W	3496	4822 050 21002	1k 1% 0,6W
3401	4822 051 20101	100 Ω 5% 0,1W	3497	4822 050 22203	22k 1% 0,6W
3402	4822 051 20101	100 Ω 5% 0,1W	3498	4822 051 10102	1k 2% 0,25W
3403	4822 051 20101	100 Ω 5% 0,1W	3499	4822 051 20223	22k 5% 0,1W
3404	4822 051 20101	100 Ω 5% 0,1W	3500	4822 051 20223	22k 5% 0,1W
3420	4822 052 10478	4 Ω 7 5% 0,33W	3501	4822 050 22203	22k 1% 0,6W
3421	4822 051 20103	10k 5% 0,1W	3502	4822 050 22203	22k 1% 0,6W
3422	4822 052 10478	4 Ω 7 5% 0,33W	3503	4822 050 21002	1k 1% 0,6W
3423	4822 050 23001	300 Ω 1% 0,6W	3504	4822 051 20103	10k 5% 0,1W
3424	4822 051 20103	10k 5% 0,1W	3505	4822 051 20223	22k 5% 0,1W
3425	4822 051 20104	100k 5% 0,1W	3508	4822 050 22203	22k 1% 0,6W
3426	4822 051 20104	100k 5% 0,1W	3509	4822 050 22203	22k 1% 0,6W
3427	4822 051 20331	330 Ω 5% 0,1W	3510	4822 050 22203	22k 1% 0,6W
3428	4822 051 20274	270k 5% 0,1W	3511	4822 050 22203	22k 1% 0,6W
3429	4822 051 20152	1k5 5% 0,1W	3512	4822 050 22203	22k 1% 0,6W
3430	4822 051 20682	6k8 5% 0,1W	3513	4822 050 21002	1k 1% 0,6W
3431	4822 051 20272	2k7 5% 0,1W	3514	4822 050 21002	1k 1% 0,6W
3432	4822 051 20682	6k8 5% 0,1W	3515	4822 050 21002	1k 1% 0,6W
3433	4822 051 20479	47 Ω 5% 0,1W	3516	4822 051 20472	4k7 5% 0,1W
3434	4822 051 20273	47k 5% 0,1W	3517	4822 051 20153	15k 5% 0,1W
3435	4822 051 20103	10k 5% 0,1W	3518	4822 051 20272	2k7 5% 0,1W
3436	4822 051 20759	75 Ω 5% 0,1W	3519	4822 051 20473	47k 5% 0,1W
3437	4822 050 21002	1k 1% 0,6W	3520	4822 050 21002	1k 1% 0,6W
3438	4822 051 20105	1M 5% 0,1W	3521	4822 051 10102	1k 2% 0,25W
3439	4822 051 20223	22k 5% 0,1W	3522	4822 050 23483	34k8 1% 0,6W



					
3523	4822 050 23483	34k8 1% 0,6W	6420	4822 130 30862	BZX79-C9V1
3524	4822 050 21783	17k8 1% 0,6W	6482	4822 130 31983	BAT85
3525	4822 050 28662	8k66 1% 0,6W	6483	4822 130 31983	BAT85
3526	4822 050 21003	10k 1% 0,6W	6540	4822 130 30621	1N4148
3527	4822 050 21003	10k 1% 0,6W	6541	4822 130 30621	1N4148
3528	4822 050 21002	1k 1% 0,6W	6750	4822 130 30621	1N4148
3529	4822 050 21003	10k 1% 0,6W	6751	4822 130 30621	1N4148
3530	4822 050 21002	1k 1% 0,6W	6752	4822 130 30621	1N4148
3531	4822 050 21003	10k 1% 0,6W	6753	4822 130 30621	1N4148
3532	4822 050 21002	1k 1% 0,6W	6754	4822 130 30621	1N4148
3533	4822 050 21003	10k 1% 0,6W	6755	4822 130 30621	1N4148
3534	4822 050 21002	1k 1% 0,6W	6756	4822 130 30621	1N4148
3535	4822 050 21003	10k 1% 0,6W	6757	4822 130 30621	1N4148
3536	4822 051 20103	10k 5% 0,1W	6758	4822 130 30621	1N4148
3537	4822 051 20103	10k 5% 0,1W	6759	4822 130 30621	1N4148
3538	4822 051 20824	820k 5% 0,1W	6760	4822 130 34174	BZX79-C4V7
3539	4822 051 20103	10k 5% 0,1W	6761	4822 130 34174	BZX79-C4V7
3540	4822 051 20223	22k 5% 0,1W	7300	5322 209 86234	NE5532N
3541	4822 051 20473	47k 5% 0,1W	7340	4822 209 30728	AK5326
3542	4822 051 20183	18k 5% 0,1W	7341	4822 209 30736	MC74HC163D
3543	4822 051 20103	10k 5% 0,1W	7342	4822 209 30736	MC74HC163D
3544	4822 051 20103	10k 5% 0,1W	7343	4822 209 30739	MC74HC04AD
3545	4822 051 20391	390Ω 5% 0,1W	7344	4822 209 30721	MC74HC74AD
3550	4822 051 10101	100Ω 2% 0,25W	7345	4822 130 42696	BC818-25
3551	4822 051 10101	100Ω 2% 0,25W	7346	4822 130 61207	BC848
3552	4822 052 10478	4Ω 5% 0,33W	7347	5322 209 11222	MC7905CT
3553	4822 051 20103	10k 5% 0,1W	7370	4822 209 30716	CDCE
3554	4822 050 22203	22k 1% 0,6W	7371	4822 209 63925	FCB61C65L-70T
3555	4822 050 22203	22k 1% 0,6W	7372	4822 209 30726	MC74HC4046AD
3556	4822 050 22203	22k 1% 0,6W	7373	4822 209 83163	LM833N
3557	4822 050 22203	22k 1% 0,6W	7374	4822 209 30735	MC74HC175D
3750	4822 050 21004	100k 1% 0,6W	7375	4822 209 30719	MC74HC00AD
3751	4822 050 21004	100k 1% 0,6W	7400	4822 209 30703	MC74HC157AD
3752	4822 050 21004	100k 1% 0,6W	7420	4822 209 30718	M51581FP
3753	4822 050 21004	100k 1% 0,6W	7421	4822 130 31129	BB212
3754	4822 050 21004	100k 1% 0,6W	7422	5322 209 82941	LM358D
3755	4822 050 21004	100k 1% 0,6W	7423	4822 130 61207	BC848
3756	4822 050 22004	100k 1% 0,6W	7424	5322 130 42012	BC858
3757	4822 050 22004	100k 1% 0,6W	7425	4822 209 30734	MC74HC4053N
3758	4822 050 22004	100k 1% 0,6W	7426	4822 130 61207	BC848
3759	4822 050 22004	100k 1% 0,6W	7427	4822 130 61207	BC848
3760	4822 051 20103	10k 5% 0,1W	7450	4822 209 30717	WPC
3761	4822 051 20103	10k 5% 0,1W	7451	4822 209 30732	LM319D
3762	4822 051 20394	390k 5% 0,1W	7452	4822 209 83163	LM833N
3763	4822 051 20394	390k 5% 0,1W	7480	4822 209 30715	MC68HC11F1
3764	4822 051 20472	4k7 5% 0,1W	7481	4822 209 30729	AM27C512-150PC
3765	4822 051 20472	4k7 5% 0,1W	7482	4822 209 30727	X28C64P-20
3766	4822 051 20472	4k7 5% 0,1W	7483	4822 209 30722	MC74HC139AD
3767	4822 051 20472	4k7 5% 0,1W	7484	4822 209 30719	MC74HC00AD
3768	4822 051 20183	18k 5% 0,1W	7485	4822 209 30741	SAD1009T/03
3769	4822 051 20183	18k 5% 0,1W	7486	4822 209 30724	MC74HC374ADW
3770	4822 051 20183	18k 5% 0,1W	7487	4822 209 30724	MC74HC374ADW
3771	4822 051 20183	18k 5% 0,1W	7488	4822 209 30723	MC74HC373ADW
3772	4822 052 10339	33Ω 5% 0,33W	7490	5322 130 42012	BC858
3773	4822 052 10339	33Ω 5% 0,33W	7491	4822 209 70941	MC34084P
3774	4822 052 10339	33Ω 5% 0,33W	7492	5322 209 81331	MC7805ACT
3775	4822 052 10339	33Ω 5% 0,33W	7542	4822 130 44197	BC558B
4400	4822 051 10008	Chip jumper	7543	4822 130 61207	BC848
4401	4822 051 10008	Chip jumper	7750	4822 209 70941	MC34084P
4481	4822 051 10008	Chip jumper	7751	4822 209 83163	LM833N
4482	4822 051 10008	Chip jumper	7752	4822 130 61207	BC848
4484	4822 051 10008	Chip jumper	7753	4822 130 61207	BC848
			7754	4822 130 61207	BC848
			7755	4822 130 61207	BC848
					
5340	4822 157 51235	COIL 4,7μH 10%			

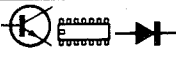

DECODER PANEL

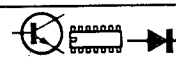

Miscellaneous					
1140	4822 276 12339	SWITCH,PUSHBUT.	3105	4822 051 20223	22k 5% 0,1W
1170	4822 218 21019	REMOTE CONTROL PLT102	3106	4822 051 10102	1k 2% 0,25W
HF transformer			3108	4822 051 20101	100Ω 5% 0,1W
1180	4822 148 80281	HF TRANSFORMER	3129	4822 051 20223	22k 5% 0,1W
			3130	4822 051 20223	22k 5% 0,1W
2090	4822 122 33175	2,2nF 20% 50V	3140	4822 052 10478	4Ω7 5% 0,33W
2091	4822 124 40272	33μF 20% 16V	3141	4822 051 20223	22k 5% 0,1W
2092	4822 122 33809	22nF 20% 50V	3142	4822 051 20472	4k7 5% 0,1W
2093	4822 121 51252	470nF 5% 63V	3143	4822 051 20101	100Ω 5% 0,1W
2094	4822 124 41576	2,2μF 20% 50V	3144	4822 051 20101	100Ω 5% 0,1W
2095	4822 124 40272	33μF 20% 16V	3159	4822 051 20563	56k 5% 0,1W
2096	4822 122 33809	22nF 20% 50V	3160	4822 051 20101	100Ω 5% 0,1W
2097	5322 122 32452	47pF 5% 50V	3161	4822 051 20101	100Ω 5% 0,1W
2098	4822 122 33809	22nF 20% 50V	3162	4822 051 20101	100Ω 5% 0,1W
2099	5322 122 32531	100pF 5% 50V	3163	4822 051 20101	100Ω 5% 0,1W
2140	4822 122 33809	22nF 20% 50V	3164	4822 051 20122	1k2 5% 0,1W
2141	5322 122 32659	33pF 5% 50V	3165	4822 051 20122	1k2 5% 0,1W
2142	5322 122 32659	33pF 5% 50V	3166	4822 051 20122	1k2 5% 0,1W
2160	4822 122 33172	390pF 5% 50V	3167	4822 051 20122	1k2 5% 0,1W
2161	4822 122 33172	390pF 5% 50V	3168	4822 051 20101	100Ω 5% 0,1W
2162	4822 122 33172	390pF 5% 50V	3169	4822 051 20272	2k7 5% 0,1W
2163	4822 122 33172	390pF 5% 50V	3170	4822 052 10478	4Ω7 5% 0,33W
2170	4822 122 33809	22nF 20% 50V	3171	4822 051 20822	8k2 5% 0,1W
2171	4822 124 40272	33μF 20% 16V	3180	4822 051 20561	560Ω 5% 0,1W
2180	4822 122 33105	56nF 10% 63V	3181	4822 051 20621	620Ω 5% 0,1W
2181	4822 122 33105	56nF 10% 63V	3190	4822 052 10108	1Ω 5% 0,33W
2182	4822 122 33496	100nF 10% 63V	3191	4822 051 20101	100Ω 5% 0,1W
2190	4822 124 40272	33μF 20% 16V	3195	4822 051 20101	100Ω 5% 0,1W
2191	4822 122 33496	100nF 10% 63V	3196	4822 051 20103	10k 5% 0,1W
2192	5322 122 32659	33pF 5% 50V	3197	4822 051 20223	22k 5% 0,1W
2196	5322 122 32659	33pF 5% 50V	3198	4822 051 20472	4k7 5% 0,1W
2230	4822 122 10166	22nF 30% 16V	3199	4822 051 20103	10k 5% 0,1W
2231	5322 122 32531	100pF 5% 50V	3230	4822 051 10101	100Ω 2% 0,25W
2232	5322 122 32531	100pF 5% 50V	3231	4822 052 10478	4Ω7 5% 0,33W
2250	4822 122 33809	22nF 20% 50V	3232	4822 051 20223	22k 5% 0,1W
2260	4822 122 33809	22nF 20% 50V	3233	4822 051 20223	22k 5% 0,1W
2261	4822 122 33809	22nF 20% 50V	3234	4822 051 20223	22k 5% 0,1W
2262	4822 122 33809	22nF 20% 50V	3235	4822 051 20101	100Ω 5% 0,1W
2263	4822 122 33809	22nF 20% 50V	3236	4822 051 20101	100Ω 5% 0,1W
2264	4822 124 41525	100μF 20% 25V	3237	4822 051 20223	22k 5% 0,1W
2265	4822 124 41525	100μF 20% 25V	3250	4822 052 10478	4Ω7 5% 0,33W
2266	4822 124 41525	100μF 20% 25V	3251	4822 051 10102	1k 2% 0,25W
2267	4822 124 41525	100μF 20% 25V	3260	4822 050 21203	12k 1% 0,6W
2268	4822 124 22339	100μF 20% 16V Bipolar	3261	4822 050 21203	12k 1% 0,6W
2269	4822 124 22339	100μF 20% 16V Bipolar	3262	4822 050 21003	12k 1% 0,6W
2280	4822 122 10166	22nF 30% 16V	3263	4822 050 21003	12k 1% 0,6W
			3272	4822 052 10339	33Ω 5% 0,33W
3090	4822 051 20222	2k2 5% 0,1W	3273	4822 052 10339	33Ω 5% 0,33W
3091	4822 051 20223	22k 5% 0,1W	3274	4822 052 10339	33Ω 5% 0,33W
3092	4822 051 20223	22k 5% 0,1W	3275	4822 052 10339	33Ω 5% 0,33W
3093	4822 051 20223	22k 5% 0,1W	3276	4822 051 20103	10k 5% 0,1W
3094	4822 052 10108	1Ω 5% 0,33W	3277	4822 051 20103	10k 5% 0,1W
3095	4822 051 20103	10k 5% 0,1W	3280	4822 051 20223	22k 5% 0,1W
3097	4822 051 20759	75Ω 5% 0,1W	3281	4822 052 10478	4Ω7 5% 0,33W
3098	4822 051 20392	3k9 5% 0,1W	3282	4822 051 20223	22k 5% 0,1W
3099	4822 051 20912	9k1 5% 0,1W	3801	4822 051 10008	Chip jumper
3100	4822 051 20162	1k6 5% 0,1W	3802	4822 051 10008	Chip jumper
3101	4822 052 10478	4Ω7 5% 0,33W	3803	4822 051 10008	Chip jumper
3102	4822 051 20223	22k 5% 0,1W	3804	4822 051 10008	Chip jumper
3103	4822 051 20223	22k 5% 0,1W	3805	4822 051 10008	Chip jumper
3104	4822 051 20223	22k 5% 0,1W	3806	4822 051 10008	Chip jumper
			3807	4822 051 10008	Chip jumper
			3808	4822 051 10008	Chip jumper
			3809	4822 051 10008	Chip jumper
			3810	4822 051 10008	Chip jumper
			3812	4822 051 10008	Chip jumper

	3813 4822 051 10008 Chip jumper	5160 4822 157 60363 COIL
3814 4822 051 10008 Chip jumper		
3815 4822 051 10008 Chip jumper		
3816 4822 051 10008 Chip jumper	6141 4822 130 42696 BC818-25	
3817 4822 051 10008 Chip jumper	6160 4822 130 31981 BZX79-C3V9	
3818 4822 051 10008 Chip jumper	6161 4822 130 30621 1N4148	
3819 4822 051 10008 Chip jumper	6162 4822 130 30621 1N4148	
3820 4822 051 10008 Chip jumper	7090 4822 209 61759 SAA7310GP/H5	
3821 4822 051 10008 Chip jumper	7091 4822 209 70422 MN4264-15	
3822 4822 051 10008 Chip jumper	7092 4822 130 42131 BF550	
3823 4822 051 10008 Chip jumper	7140 4822 209 30719 MC74HC00AD	
3825 4822 051 10008 Chip jumper	7160 4822 130 42696 BC818-25	
3828 4822 051 10008 Chip jumper	7161 4822 130 42696 BC818-25	
3845 4822 051 10008 Chip jumper	7162 4822 130 42696 BC818-25	
4160 4822 051 10008 Chip jumper	7163 4822 130 42696 BC818-25	
4190 4822 051 10008 Chip jumper	7164 5322 130 42012 BC858	
4191 4822 051 10008 Chip jumper	7190 4822 209 72545 SAA7220P/B	
4192 4822 051 10008 Chip jumper	7191 4822 130 61207 BC848	
4193 4822 051 10008 Chip jumper	7192 4822 130 42696 BC818-25	
4230 4822 051 10008 Chip jumper	7230 4822 209 30703 MC74HC157AD	
4260 4822 051 10008 Chip jumper	7250 4822 209 30721 MC74HC74AD	
4261 4822 051 10008 Chip jumper	7260 5322 209 86234 NE5532N	
4262 4822 051 10008 Chip jumper	7261 5322 209 86234 NE5532N	
4263 4822 051 10008 Chip jumper	7280 4822 209 30719 MC74HC00AD	
4264 4822 051 10008 Chip jumper		



LEVEL AND BALANCE PANEL



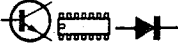

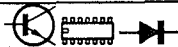

	2556 4822 124 22339 100µF 20% 16V Bipolar		3550 4822 102 50056 3x10k 20% Potm LEVEL
2557 4822 124 22339 100µF 20% 16V Bipolar			3551 2x10k Potm BALANCE
2558 4822 124 22339 100µF 20% 16V Bipolar			3552 4822 050 22003 20k 1% 0,6W
2559 4822 124 22339 100µF 20% 16V Bipolar			3553 4822 050 22003 20k 1% 0,6W
2560 4822 124 40433 47µF 20% 25V			3554 4822 050 28202 8k2 1% 0,6W
2561 4822 124 40433 47µF 20% 25V			3555 4822 050 28202 8k2 1% 0,6W
2562 4822 122 10166 22nF 30% 16V			3556 4822 050 24701 470Ω 1% 0,6W
2563 4822 122 10166 22nF 30% 16V			3557 4822 050 24701 470Ω 1% 0,6W
2564 4822 122 10166 22nF 30% 16V			3558 4822 050 24701 470Ω 1% 0,6W
2565 4822 122 10166 22nF 30% 16V			3559 4822 050 24701 470Ω 1% 0,6W
2566 4822 124 40433 47µF 20% 25V			
2567 4822 124 40433 47µF 20% 25V			6550 4822 130 34167 BZX79-C6V2
			6551 4822 130 34167 BZX79-C6V2
			6552 4822 130 34167 BZX79-C6V2
			6553 4822 130 34167 BZX79-C6V2
			7550 5322 209 86234 NE5532N
			7551 5322 209 86234 NE5532N



					
2001	4822 124 42355	10µF 20% 50V	3001	4822 051 10103	10k 2% 0,25W
2002	4822 124 42355	10µF 20% 50V	3002	4822 051 10103	10k 2% 0,25W
2003	4822 121 51093	6,8nF 10% 63V	3003	5322 116 80427	1k 1% 0,125W
2004	4822 121 51093	6,8nF 10% 63V	3004	5322 116 80427	1k 1% 0,125W
2005	4822 126 10324	33pF 63V	3005	4822 051 10109	10Ω 2% 0,25W
2006	4822 126 10324	33pF 63V	3006	4822 051 10109	10Ω 2% 0,25W
2007	5322 121 42386	100nF 5% 50V	3013	4822 051 53302	3k3 1% 0,125W
2008	5322 121 42386	100nF 5% 50V	3014	4822 051 53302	3k3 1% 0,125W
2009	5322 121 42386	100nF 5% 50V	3015	4822 051 55101	510Ω 1% 0,125W
2010	5322 121 42386	100nF 5% 50V	3016	4822 051 55101	510Ω 1% 0,125W
2011	5322 121 42386	100nF 5% 50V	3017	4822 051 51203	12k 1% 0,125W
2012	5322 121 42386	100nF 5% 50V	3018	4822 051 51203	12k 1% 0,125W
2013	4822 124 42355	10µF 20% 50V	3019	4822 051 58203	82k 1% 0,125W
2014	4822 124 42355	10µF 20% 50V	3020	4822 051 58203	82k 1% 0,125W
2015	4822 124 42355	10µF 20% 50V	3021	4822 051 54702	4k7 1% 0,125W
2016	4822 124 42355	10µF 20% 50V	3022	4822 051 54702	4k7 1% 0,125W
2201	4822 124 42354	100µF 20% 16	3023	4822 051 54703	47k 1% 0,125W
2202	4822 124 42354	100µF 20% 16	3024	4822 051 54703	47k 1% 0,125W
2203	4822 124 42354	100µF 20% 16	3027	4822 051 54701	470Ω 1% 0,125W
2204	4822 124 42354	100µF 20% 16	3028	4822 051 54701	470Ω 1% 0,125W
2205	4822 122 32083	8,2pF 5% 63V	3033	4822 051 51802	1k8 1% 0,125W
2206	4822 122 32083	8,2pF 5% 63V	3034	4822 051 51802	1k8 1% 0,125W
2207	4822 122 32083	8,2pF 5% 63V	3035	4822 051 54703	47k 1% 0,125W
2208	4822 122 32083	8,2pF 5% 63V	3036	4822 051 54703	47k 1% 0,125W
2209	4822 122 31765	100pF 5% 63V	3037	4822 051 10829	82Ω 2% 0,25W
2210	4822 122 31765	100pF 5% 63V	3201	4822 051 56803	68k 1% 0,125W
2211	4822 122 31765	100pF 5% 63V	3202	4822 051 56803	68k 1% 0,125W
2212	4822 122 31765	100pF 5% 63V	3203	4822 051 54703	47k 1% 0,125W
2213	4822 124 42354	100µF 20% 16	3204	4822 051 54703	47k 1% 0,125W
2214	4822 124 42354	100µF 20% 16	3205	4822 051 54703	47k 1% 0,125W
2331	4822 124 42355	10µF 20% 50V	3206	4822 051 54703	47k 1% 0,125W
2332	4822 124 42355	10µF 20% 50V	3207	4822 051 51503	15k 1% 0,125W
2333	4822 124 42355	10µF 20% 50V	3208	4822 051 51503	15k 1% 0,125W
2334	4822 124 42355	10µF 20% 50V	3209	4822 051 51503	15k 1% 0,125W
2335	4822 122 31746	1nF 5% 63V	3210	4822 051 51503	15k 1% 0,125W
2336	4822 122 31746	1nF 5% 63V	3211	4822 051 54702	4k7 1% 0,125W
2337	4822 124 42354	100µF 20% 16	3212	4822 051 54702	4k7 1% 0,125W
2338	4822 124 42354	100µF 20% 16	3213	4822 051 54702	4k7 1% 0,125W
2339	4822 121 70052	15nF 5% 63V	3214	4822 051 54702	4k7 1% 0,125W
2340	4822 121 70052	15nF 5% 63V	3215	4822 051 54702	4k7 1% 0,125W
2401	4822 124 42355	10µF 20% 50V	3216	4822 051 54702	4k7 1% 0,125W
2402	4822 124 42355	10µF 20% 50V	3217	4822 051 54702	4k7 1% 0,125W
2403	4822 124 42355	10µF 20% 50V	3218	4822 051 54702	4k7 1% 0,125W
2404	4822 124 42355	10µF 20% 50V	3219	4822 051 54703	47k 1% 0,125W
2405	4822 124 42355	10µF 20% 50V	3220	4822 051 54703	47k 1% 0,125W
2406	4822 124 42355	10µF 20% 50V	3331	4822 051 55602	5k6 1% 0,125W
2407	4822 124 42355	10µF 20% 50V	3332	4822 051 55602	5k6 1% 0,125W
2408	4822 124 42355	10µF 20% 50V	3333	4822 051 55602	5k6 1% 0,125W
2421	4822 124 42355	10µF 20% 50V	3334	4822 051 55602	5k6 1% 0,125W
2422	4822 124 42355	10µF 20% 50V	3335	5322 116 80427	1k 1% 0,125W
2423	4822 124 42355	10µF 20% 50V	3336	5322 116 80427	1k 1% 0,125W
2424	4822 124 42355	10µF 20% 50V	3337	5322 116 80445	4k7 1% 0,125W
2431	4822 124 42355	10µF 20% 50V	3338	5322 116 80445	4k7 1% 0,125W
2432	4822 124 42355	10µF 20% 50V	3339	4822 051 55602	5k6 1% 0,125W
2433	4822 124 42355	10µF 20% 50V	3340	4822 051 55602	5k6 1% 0,125W
2434	4822 124 42355	10µF 20% 50V	3341	4822 051 56803	68k 1% 0,125W
2435	4822 124 42355	10µF 20% 50V	3342	4822 051 56803	68k 1% 0,125W
2436	4822 124 42355	10µF 20% 50V	3343	4822 051 51503	15k 1% 0,125W
2437	4822 124 42355	10µF 20% 50V	3344	4822 051 51503	15k 1% 0,125W
2438	4822 124 42355	10µF 20% 50V	3345	5322 116 80445	4k7 1% 0,125W
2440	4822 124 42355	10µF 20% 50V	3346	5322 116 80445	4k7 1% 0,125W
2441	4822 124 42355	10µF 20% 50V	3347	4822 100 10875	2K2 20% Trimpot
2501	4822 124 42355	10µF 20% 50V	3348	4822 100 10875	2K2 20% Trimpot
			3349	4822 051 55101	510Ω 1% 0,125W
			3350	4822 051 55101	510Ω 1% 0,125W

	3351 4822 051 55101 510Ω 1% 0,125W	
	3352 4822 051 55101 510Ω 1% 0,125W	
	3401 4822 116 81207 47Ω 1% 0,4W	
	3402 4822 116 81207 47Ω 1% 0,4W	
	3403 4822 116 81207 47Ω 1% 0,4W	
	3404 4822 116 81207 47Ω 1% 0,4W	
	3405 4822 116 81207 47Ω 1% 0,4W	
	3406 4822 116 81207 47Ω 1% 0,4W	
	3407 4822 116 81207 47Ω 1% 0,4W	
	3408 4822 116 81207 47Ω 1% 0,4W	
	3409 4822 116 81207 47Ω 1% 0,4W	
	3422 4822 116 81207 47Ω 1% 0,4W	
	3423 4822 116 81207 47Ω 1% 0,4W	
	3424 4822 116 81207 47Ω 1% 0,4W	
	3431 4822 116 81207 47Ω 1% 0,4W	
	3432 4822 116 81207 47Ω 1% 0,4W	
	3433 4822 116 81207 47Ω 1% 0,4W	
	3434 4822 116 81207 47Ω 1% 0,4W	
	3435 4822 116 81207 47Ω 1% 0,4W	
	3436 4822 116 81207 47Ω 1% 0,4W	
	3437 4822 116 81207 47Ω 1% 0,4W	
	3438 4822 116 81207 47Ω 1% 0,4W	
	3501 5322 116 80426 100Ω 1% 0,125W	
	3502 4822 116 81198 15k 1% 0,125W	
	3503 5322 116 80429 100k 1% 0,125W	
	3504 4822 051 10274 270k 2% 0,25W	
	3505 5322 116 80446 47k 1% 0,125W	
	3506 5322 116 80438 330Ω 1% 0,125W	
	5000 4822 280 20495 REEDRELAIS LM44E	
	5001 4822 280 20495 REEDRELAIS LM44E	
	5301 4822 148 81219 TRANSFORMER	
	5302 4822 148 81219 TRANSFORMER	
	5501 4822 280 20495 TO 1351 4010 REEDRELAIS LM44E	
	6005 4822 130 30621 1N4148	
	6006 4822 130 30621 1N4148	
	6501 4822 130 30621 1N4148	
	6502 4822 130 30621 1N4148	
	6503 4822 130 30621 1N4148	
	7005 4822 209 63706 LM833M	
	7006 4822 209 63706 LM833M	
	7009 4822 209 63706 LM833M	
	7010 4822 209 63706 LM833M	
	7201 4822 209 63706 LM833M	
	7202 4822 209 63706 LM833M	
	7331 4822 209 30803 NE5532 SO	
	7332 4822 209 30803 NE5532 SO	
	7501 4822 209 81397 TL431 CLP	



HEADPHONE PANEL

	2580 5322 124 21762 100μF 20% 10V	
	2581 5322 124 21762 100μF 20% 10V	
	2582 5322 124 21711 100μF 20% 25V	
	2583 5322 124 21711 100μF 20% 25V	
	7580 4822 130 40958 BC338-25	
	7581 4822 130 40958 BC338-25	
	7582 4822 209 82362 NJM4556D	
	3580 4822 051 10101 100Ω 2% 0,25W	
	3581 4822 051 10101 100Ω 2% 0,25W	
	3582 4822 102 10398 10k 20% LOG	
	3584 4822 050 21203 12k 1% 0,6W	
	3585 4822 050 21203 12k 1% 0,6W	
	3586 4822 116 52264 27k 5% 0,5W	
	3587 4822 116 52264 27k 5% 0,5W	
	3588 4822 052 10109 10Ω 5% 0,33W	
	3589 4822 052 10109 10Ω 5% 0,33W	
	3590 4822 051 10122 1k2 2% 0,25W	
	3591 4822 051 10122 1k2 2% 0,25W	
	3592 4822 050 21201 120Ω 1% 0,6W	
	3593 4822 050 21201 120Ω 1% 0,6W	

Miscellaneous														
1502	4822 276 11309	SWITCH,PUSHBUT. SDDL	D 18	5322 130 32677	1N5822									
2000	4822 126 10454	3,3nF 20% 400V	D 19	5322 130 34464	1N4448									
5001	4822 146 31048	TRANSFORMER UNIT	D 20	4822 130 82272	1N4004									
 C 1 4822 124 41184 470µF 20% 50V C 2 5322 124 22614 1000µF 20% 50V C 3 4822 121 41856 22nF 5% 250V C 4 4822 124 40207 100µF 20% 25V C 5 4822 121 41856 22nF 5% 250V C 6 4822 124 40207 100µF 20% 25V C 7 4822 121 41856 22nF 5% 250V C 8 4822 124 40207 100µF 20% 25V C 9 4822 121 41856 22nF 5% 250V C 10 4822 124 40207 100µF 20% 25V C 11 4822 121 41856 22nF 5% 250V C 12 4822 124 40207 100µF 20% 25V C 13 4822 121 41856 22nF 5% 250V C 14 4822 124 40207 100µF 20% 25V C 15 4822 121 41856 22nF 5% 250V C 16 4822 124 40207 100µF 20% 25V C 17 4822 121 41856 22nF 5% 250V C 18 5322 124 22229 1000µF 20% 35V C 19 5322 121 42386 100nF 5% 63V C 20 4822 124 80045 4700µF 20% 50V C 21 4822 124 80045 4700µF 20% 50V C 22 4822 124 80045 4700µF 20% 50V C 23 4822 124 40255 100µF 20% 63V C 24 4822 121 51252 0,47µF 5% 63V C 25 4822 124 40244 2,2µF 20% 63V C 26 5322 122 32818 2,2nF 10% 100V C 27 5322 121 42489 33nF 5% 250V C 28 5322 124 22614 1000µF 20% 50V C 29 4822 122 32121 390pF 2% 100V C 30 5322 121 42386 100nF 5% 63V C 31 4822 124 41751 47µF 20% 50V C 32 4822 124 80045 4700µF 20% 50V C 33 4822 124 80045 4700µF 20% 50V C 34 5322 124 22614 1000µF 20% 50V C 35 4822 121 41856 22nF 5% 250V C 36 4822 124 40246 4,7µF 20% 63V C 60 4822 121 41856 22nF 5% 250V C 61 4822 124 40255 100µF 20% 63V			D 21	4822 130 82272	1N4004									
			D 22	4822 130 82272	1N4004									
			D 23	4822 130 82272	1N4004									
			D 24	5322 130 34464	1N4448									
			D 32	5322 130 34464	1N4448									
			D 33	5322 130 34464	1N4448									
			D 34	4822 130 82272	1N4004									
			D 35	4822 130 82272	1N4004									
			DV 1	4822 130 30682	BZX79B9V1									
			DV 2	4822 130 31981	BZX79B3V9									
			DV 3	4822 130 34174	BZX79B4V7									
			DZ 1	5322 130 50399	B40C3700/2200									
			DZ 2	5322 130 34962	B40C5000/3300									
			 IC 2 5322 209 81236 LM337KC IC 3 5322 209 81236 LM337KC IC 4 4822 209 80591 LM317SP IC 5 4822 209 80591 LM317SP IC 6 4822 209 80591 LM317SP IC 7 5322 209 81236 LM337KC IC 8 5322 209 81236 LM337KC IC 9 5322 209 70292 L296 IC 10 4822 209 30987 MC34160			 L 1 4822 158 10879 TOR. CHOKE 250µH L 2 4822 158 10878 TOR. CHOKE 72µH								
									 Q 1 4822 130 41096 BC550C Q 2 4822 130 41096 BC550C Q 3 4822 130 41096 BC550C Q 4 4822 130 61755 BC560C Q 5 4822 130 41096 BC550C Q 7 4822 130 41096 BC550C					
						 R 4 4822 050 23902 3k9 1% 0,6W R 5 4822 050 26801 680Ω 1% 0,6W R 6 4822 050 26802 6k8 1% 0,6W R 7 4822 050 21502 1k5 1% 0,6W R 8 4822 050 26802 6k8 1% 0,6W R 9 4822 050 26801 680Ω 1% 0,6W R 11 4822 050 22201 220Ω 1% 0,6W R 12 4822 050 21001 100Ω 1% 0,6W R 13 4822 050 22201 220Ω 1% 0,6W R 14 4822 050 21001 100Ω 1% 0,6W R 15 4822 050 21001 100Ω 1% 0,6W R 16 4822 050 21002 1k 1% 0,6W R 17 4822 050 21001 100Ω 1% 0,6W R 18 4822 050 21001 100Ω 1% 0,6W R 20 4822 050 11502 1k5 1% 0,6W R 21 4822 050 21001 100Ω 1% 0,6W R 22 4822 050 21002 1k 1% 0,6W R 24 4822 050 25603 56k 1% 0,6W R 25 4822 050 22201 220Ω 1% 0,6W R 26 4822 050 26801 680Ω 1% 0,6W								
												 D 1 4822 130 82272 1N4004 D 2 4822 130 82272 1N4004 D 3 4822 130 82272 1N4004 D 4 4822 130 82272 1N4004 D 5 4822 130 82272 1N4004 D 6 4822 130 82272 1N4004 D 7 4822 130 82272 1N4004 D 8 4822 130 82272 1N4004 D 9 4822 130 82272 1N4004 D 10 4822 130 82272 1N4004 D 11 4822 130 82272 1N4004 D 12 4822 130 82272 1N4004 D 13 4822 130 82272 1N4004 D 14 4822 130 82272 1N4004 D 15 4822 130 82272 1N4004 D 16 4822 130 82272 1N4004 D 17 5322 130 34464 1N4448		

					
R 27	4822 116 83594	R-PTC 0,75A 60V	R 43	4822 050 21003	10k 1% 0,6W
R 28	4822 116 83594	R-PTC 0,75A 60V	R 44	4822 050 22203	22k 1% 0,6W
R 29	4822 116 83593	R-PTC 1,6A 50V	R 45	4822 050 24703	47k 1% 0,6W
R 30	4822 116 83593	R-PTC 1,6A 50V	R 46	4822 050 22203	22k 1% 0,6W
R 31	4822 050 24702	4k7 1% 0,6W	R 47	4822 050 22202	2k2 1% 0,6W
R 32	4822 050 25605	5M6 1% 0,6W	R 48	4822 050 22203	22k 1% 0,6W
R 33	4822 050 24703	47k 1% 0,6W	R 64	4822 050 24704	470k 1% 0,6W
R 34	4822 050 11004	100k 1% 0,6W	R 65	4822 050 22203	22k 1% 0,6W
R 35	4822 050 24302	4k3 1% 0,6W	R 66	4822 050 22403	24k 1% 0,6W
R 36	4822 050 21503	15k 1% 0,6W	R 67	4822 050 21212	1k2 1% 0,6W
R 37	4822 050 21003	10k 1% 0,6W			
R 38	4822 050 23902	3k9 1% 0,6W			
R 40	5322 116 90018	0Ω			
R 41	4822 050 21003	10k 1% 0,6W	S 11	5322 209 81236	LM337KC
R 42	4822 050 21504	150k 1% 0,6W			

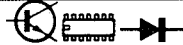
BS DAC PANEL

					
CD09	4822 126 12049	47nF 63V	QD01	4822 701 11933	SAA7350GP
CD10	4822 124 40433	47μF 20% 25V	Q511	4822 209 30264	SM5840FP
CD11	4822 126 12049	47nF 63V	Q512	4822 209 30985	PST523C
CD12	4822 126 12049	47nF 63V	Q601	5322 209 86234	NE5532N
CD13	4822 124 40433	47μF 20% 25V	Q602	5322 209 50602	NE5532N
CD14	4822 124 40433	47μF 20% 25V			
CD15	4822 126 12049	47nF 63V			
CD16	4822 126 12049	47nF 63V	RD09	4822 052 10478	4Ω7 5% 0,33W
CD17	4822 124 40433	47μF 20% 25V	RD10	4822 052 10478	4Ω7 5% 0,33W
CD18	4822 124 40433	47μF 20% 25V	RD11	4822 052 10478	4Ω7 5% 0,33W
CD19	4822 126 12049	47nF 63V	RD12	4822 116 52261	24k 5% 0,5W
CD20	4822 126 12049	47nF 63V	RD15	4822 050 21001	100Ω 1% 0,6W
CD21	4822 124 40433	47μF 20% 25V	RD16	4822 050 21001	100Ω 1% 0,6W
CD22	4822 124 40433	47μF 20% 25V	RD31	4822 050 24703	47k 1% 0,6W
CD23	4822 126 12049	47nF 63V	RD32	4822 050 24703	47k 1% 0,6W
CD24	4822 126 12049	47nF 63V	RD33	4822 050 24703	47k 1% 0,6W
CD25	4822 124 40433	47μF 20% 25V	RD34	4822 050 24703	47k 1% 0,6W
CD26	4822 124 40433	47μF 20% 25V	R512	4822 116 52234	100k 5% 0,5W
CD31	4822 126 12042	39pF 2% 63V	R513	4822 052 10478	4Ω7 5% 0,33W
CD32	4822 126 12042	39pF 2% 63V	R601	4822 050 28202	8k2 1% 0,6W
CD33	5322 121 50999	470pF 1% 400V	R602	4822 050 28202	8k2 1% 0,6W
CD34	5322 121 50999	470pF 1% 400V	R603	4822 050 28202	8k2 1% 0,6W
CD35	4822 126 12042	39pF 2% 63V	R604	4822 050 28202	8k2 1% 0,6W
CD36	4822 126 12042	39pF 2% 63V	R605	4822 050 29102	9k1 1% 0,6W
CD37	5322 121 50999	470pF 1% 400V	R606	4822 050 29102	9k1 1% 0,6W
CD38	5322 121 50999	470pF 1% 400V	R607	4822 050 29102	9k1 1% 0,6W
C512	4822 124 40244	2,2μF 20% 63V	R608	4822 050 29102	9k1 1% 0,6W
C523	4822 124 40433	47μF 20% 25V	R609	4822 050 25602	5k6 1% 0,6W
C524	4822 126 12049	47nF 63V	R610	4822 050 25602	5k6 1% 0,6W
C601	4822 121 51288	100pF 2% 630V	R611	4822 050 27502	7k5 1% 0,6W
C602	4822 121 51288	100pF 2% 630V	R612	4822 050 27502	7k5 1% 0,6W
C603	4822 121 51288	100pF 2% 630V	R613	4822 050 25602	5k6 1% 0,6W
C604	4822 121 51288	100pF 2% 630V	R614	4822 050 25602	5k6 1% 0,6W
C605	4822 121 43066	1nF 1% 400V	R615	4822 116 52175	100Ω 5% 0,5W
C606	4822 121 43066	1nF 1% 400V	R616	4822 116 52175	100Ω 5% 0,5W
C607	4822 121 51288	100pF 2% 630V	R681	4822 052 10479	47Ω 5% 0,33W
C608	4822 121 51288	100pF 2% 630V	R682	4822 052 10479	47Ω 5% 0,33W
C609	5322 122 31626	100pF 2% 500V	R683	4822 052 10479	47Ω 5% 0,33W
C610	5322 122 31626	100pF 2% 500V	R684	4822 052 10479	47Ω 5% 0,33W
C681	4822 124 41643	100μF 20% 16V			
C682	4822 124 41643	100μF 20% 16V			
C683	4822 124 41643	100μF 20% 16V			
C684	4822 124 41643	100μF 20% 16V			