

Service Manual

74 CDR620/02B/02M/06B
74 CDR615/02B/02M/06B
Compact Disc Recorder

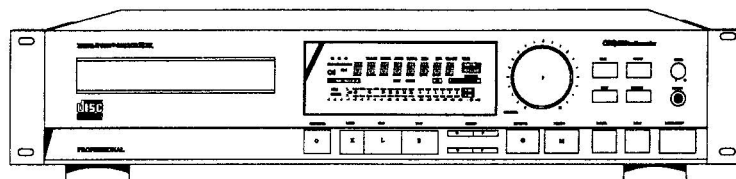

TABLE OF CONTENTS

SECTION	PAGE
1. MAIN UNIT	
1.1 WARNINGS AND SAFETY INSTRUCTIONS	1-1
1.2 INSTRUCTIONS FOR USE	1-2
1.3 TECHNICAL SPECIFICATIONS	1-7
1.4 WIRING DIAGRAM	1-9
1.5 BLOCK DIAGRAM	1-11
1.6 SCHEMATIC DIAGRAM AND PARTS LOCATION	1-14
1.7 EXPLODED VIEW AND PARTS LIST	1-51
1.8 CIRCUIT DESCRIPTION	1-54
1.9 ELECTRICAL PARTS LIST	1-81
2. CDD2000 (CDR MODULE for MARANTZ)	
2.1 LIST OF ABBREVIATIONS	2-2
2.2 BLOCK DIAGRAM	2-5
2.3 SCHEMATIC DIAGRAM AND PARTS LOCATION	2-8
2.4 EXPLODED VIEW AND PARTS LIST	2-32
2.5 ELECTRICAL PARTS LIST	2-43
3. RC620 (WIRED REMOTE CONTROL UNIT)	
3.1 BLOCK DIAGRAM	3-2
3.2 SCHEMATIC DIAGRAM AND PARTS LOCATION	3-3
3.3 EXPLODED VIEW AND PARTS LIST	3-7
3.4 ELECTRICAL PARTS LIST	3-8

Please use this service manual with referring to the user guide (D.F.U) without fail.

修理の際は、必ず取扱説明書を準備し操作方法を確認の上作業を行ってください。

marantz

model CDR620/CDR615

MARANTZ DESIGN AND SERVICE

Using superior design and selected high grade components, **MARANTZ** company has created the ultimate in stereo sound. Only original **MARANTZ** parts can insure that your **MARANTZ** product will continue to perform to the specifications for which it is famous.

Parts for your **MARANTZ** equipment are generally available to our National Marantz Subsidiary or Agent.

ORDERING PARTS :

Parts can be ordered either by mail or by Fax.. In both cases, the correct part number has to be specified.

The following information must be supplied to eliminate delays in processing your order :

1. Complete address
2. Complete part numbers and quantities required
3. Description of parts
4. Model number for which part is required
5. Way of shipment
6. Signature : any order form or Fax. must be signed, otherwise such part order will be considered as null and void.

USA

MARANTZ AMERICA, INC.
440 MEDINAH ROAD
ROSELLE, ILLINOIS 60172- 2330
USA
PHONE : 630 - 307 - 3100
FAX : 630 - 307 - 2687

CANADA

LENBROOK INDUSTRIES LIMITED
633 GRANITE COURT,
PICKERING, ONTARIO L1W 3K1
CANADA
PHONE : 416-831-6333
FAX : 416-831-6936

EUROPE

MARANTZ EUROPE B.V.
P.O. BOX 80002
BUILDING SFF2
5600 JB EINDHOVEN
THE NETHERLANDS
PHONE : +31 - 40 - 2732241
FAX : +31 - 40 - 2735578

PROFESSIONAL USA

SUPERSCOPE TECHNOLOGIES, INC.
MARANTZ PROFESSIONAL PRODUCTS
1000 CORPORATE BLVD., SUITE D
AURORA, ILLINOIS 60504 USA
PHONE : 630 - 820 - 4800
FAX : 630 - 820 - 8103

PROFESSIONAL CANADA

TC ELECTRONICS CANADA LTD
540 FIRING AVE.
BAIE D'URFÉ, QUEBEC H9X 3T2
CANADA
PHONE : 514 - 457 - 4044
FAX : 514 - 457 - 5524

TRADING

MARANTZ EUROPE B.V.
P.O. BOX 80002
BUILDING SFF2
5600 JB EINDHOVEN
THE NETHERLANDS
PHONE : +31 - 40 - 2732241
FAX : +31 - 40 - 2735578

BRAZIL

MARANTZ BRAZIL
Caixa Postal 21462
CEP 04698-970
Sao Paulo, SP, BRAZIL
PHONE : 0800 - 123123 (Discagem Direta Gratuita)
FAX : +55 11 534. 8988

THAILAND

MRZ STANDARD CO., LTD.
746 - 750 WANGBURAPA BANGKOK
10200 THAILAND
PHONE : +66 2222 9181
FAX : +66 2225 8871

HONG KONG

FORWARD INTERNATIONAL CORP.LTD.
15 TH FLOOR, REGENT CENTRE,
88 QUEEN'S ROAD, CENTRAL, H. K.
PHONE : +852 521 - 0883
FAX : +852 521 - 7835

TAIWAN

PAI-YUING CO., LTD.
6 TH FL NO, 148 SUNG KIANG ROAD,
TAIPEI, 10429, TAIWAN R.O.C.
PHONE : +886 (2) 5221304 - 8
FAX : +886 (2) 5630415

MALAYSIA

WO KEE HONG ELECTRONICS SDN. BHD.
NO. 102 JALAN SS 21/35, DAMANSARA
UTAMA, 47400 PETALING JAYA
SELANGOR DARUL EHSAN,
MALAYSIA
PHONE : +60 3 - 7184666
FAX : +60 3 - 7173828

JAPAN Technical

MARANTZ JAPAN INC.
35-1, 7- chome, Sagamiono
Sagamihara - shi, Kanagawa
Japan
PHONE : +81 427 44 7950
FAX : +81 427 48 0889

日本 マラantz 株式会社

本 社 〒228
神奈川県相模原市相模大野 7 - 35 - 1
営業本部 〒150
東京都渋谷区恵比寿南 1 - 11 - 9

SINGAPORE

FORWARD MARKETING (SINGAPORE) PTE. LTD.
29, LENG KEE ROAD
SINGAPORE 159099,
PHONE : +65 475 - 4555
FAX : +65 475 - 8623

SHOCK, FIRE HAZARD SERVICE TEST :

CAUTION : After servicing this appliance and prior to returning to customer, measure the resistance between either primary AC cord connector pins (with unit NOT connected to AC mains and its Power switch ON), and the face or Front Panel of product and controls and chassis bottom.

Any resistance measurement less than 1 Megohms should cause unit to be repaired or corrected before AC power is applied, and verified before it is return to the user/customer.

Ref. UL Standard NO. 1492.

In case of difficulties, do not hesitate to contact the Technical Department at above mentioned address.

1.1 WARNINGS AND SAFETY INSTRUCTIONS

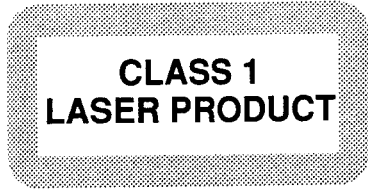

DANGER

As the laserbeam used in this equipment is harmful to the eyes do not open the set. Invisible Laser radiation when the set is open.
(Class 3B laser)

AVOID DIRECT EXPOSURE TO BEAM.

WARNING

Use of controls or adjustments or performance other than those specified herein may result in hazardous radiation exposure.

WARNING

The use of optical instruments with this product will increase eye hazard.

Laser Device Unit (LT025MD)

Material: Semiconductor

Wave length: 780 nm

Laser Output:

Read: 0.7 - 0.9 mW

Write: 12 - 14 mW



The exclamation point within an equilateral triangle is intended to alert the user to the presence of important operating and maintenance (servicing) instructions in the literature accompanying the appliance.



CLASS 3B
LASER PRODUCT

CAUTION

INVISIBLE LASER RADIATION WHEN OPEN AVOID EXPOSURE TO BEAM

VARO!

AVATTAESSA OLET ALTTIINA NÄKYMÄTTÖMÄLLE LASER SÄTTEILYLLE ÄLÄ KATSO SÄTEESSEN

VARNING

OSYNLIG LASERSTRÅLNING NÄR DENNA DEL ÄR ÖPPNAD BETRAKTA EJ STRÅLEN

ADVERSEL

USYNLIG LASERSTRÅLNING VED ÅBNING. UNDGÅ UNSAETTELSE FOR STRÅLING

DANGER

INVISIBLE LASER RADIATION WHEN OPEN AVOID DIRECT EXPOSURE TO BEAM

VORSICHT

UNSIHTBARE LASERSTRAHLUNG WENN ABDECKUNG GEÖFFNET NICHT DEM STRAHL AUSSETZEN

1.2 INSTRUCTIONS FOR USE

INTRODUCTION

Since the introduction by Marantz of the first standalone compact disc recorder (CDR) in 1991, the medium has found countless professional applications.

The multi-functional CDR620 sets new standards, with improved features such as state of the art electronics, top quality A/D and D/A converters, sample rate converter, digital audio delay and fully automatic indexing from CD, DAT, DCC and MD sources.

The CDR620 also incorporates an entirely new CD mechanism. Built around current leading edge optical technology the mechanism helps to ensure optimal data security and integrity. This leads to improved quality and reliability while maintaining backwards compatibility with existing application software. In standalone mode, CD-DA titles can be directly recorded via the professional analogue and digital audio interfaces, and the SCSI-II interface allows the recording of large quantities of data (up to 600 Mb) in one of the standard CD-formats: CD-ROM(XA), PHOTO-CD, CD-I, Video-CD and CD-DA. The drive of the CDR620 is able to read and write at double and normal transfer rate as compared to standard CD-ROM and CD-DA drives.

Using two CDR620's it is also possible to duplicate CD-DA/ROM discs via the SCSI-II interface at double speed.

The CDR620 conforms to the standards of Orange Book, Part II, which means that recorded discs can be read by CD-ROM(XA), CD-I, PHOTO-CD, Video-CD and CD-DA players.

CDR Blank discs

The CD-R blank discs as a medium are industry standard and available from various suppliers.

The CDR620 recording quality depends upon the quality of the blank CDR disc used.

CDR discs are extremely critical media, because:

- a. CDR is a write-once process
- b. CDR recorded discs need to be compatible with the Red Book standard.

Only the best quality discs should be used.

Marantz CDR discs ensure the best recording quality on your CDR620 CD recorder.

CDR620

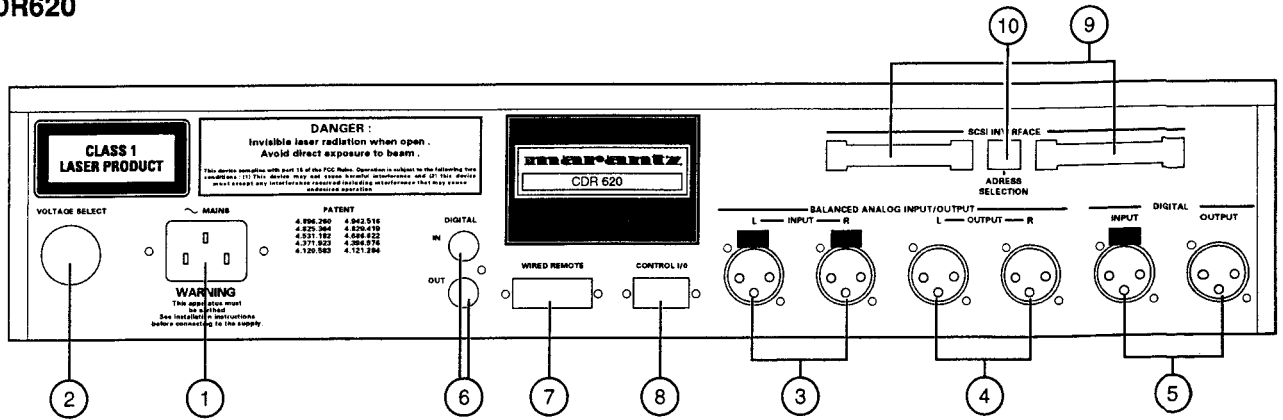

CDR615

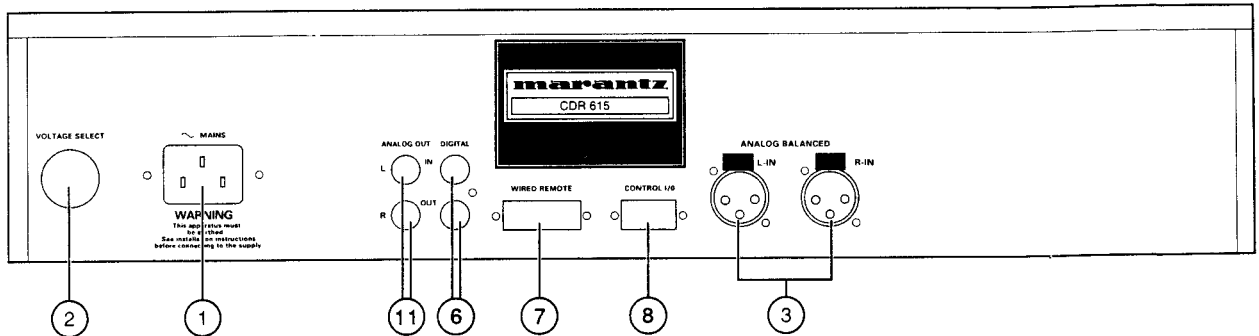

1. AC MAINS input

Connect to the grounded AC outlet with the AC power supply cord included.

2. AC MAINS VOLTAGE SELECTOR

Use this selector to adapt to your local voltage

3. ANALOGUE IN terminals

These are balanced analogue audio XLR input connectors

4. ANALOGUE OUT terminals (CDR620 ONLY)

These are balanced analogue audio XLR output connectors

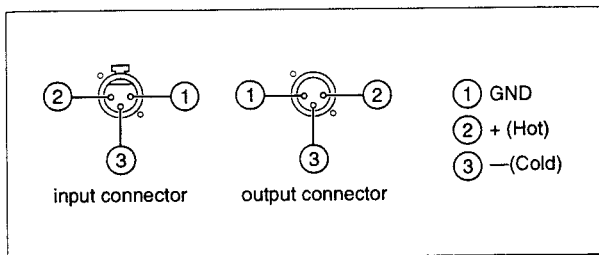

5. AES/EBU terminals (IN/OUT) (CDR620 ONLY)

These terminals are for input or output of signals for the professional digital audio interface (XLR).

6. IEC958 type II jacks (IN/OUT)

These terminals are for input or output of digital audio signals from/to a digital audio device (cinch).

7. WIRED REMOTE terminal

15-pin Sub-D connector for RC620 remote control

8. CONTROL I/O terminal

9-pin Sub-D connector for parallel control

9. SCSI-II interface (CDR620 ONLY)

Connection for host computer

10. SCSI address selection and terminator (CDR620 ONLY)

DIP switch setting of the SCSI device number of the unit and SCSI termination ON/OFF.

11. ANALOG OUTPUT COAXIAL (CDR615 ONLY)

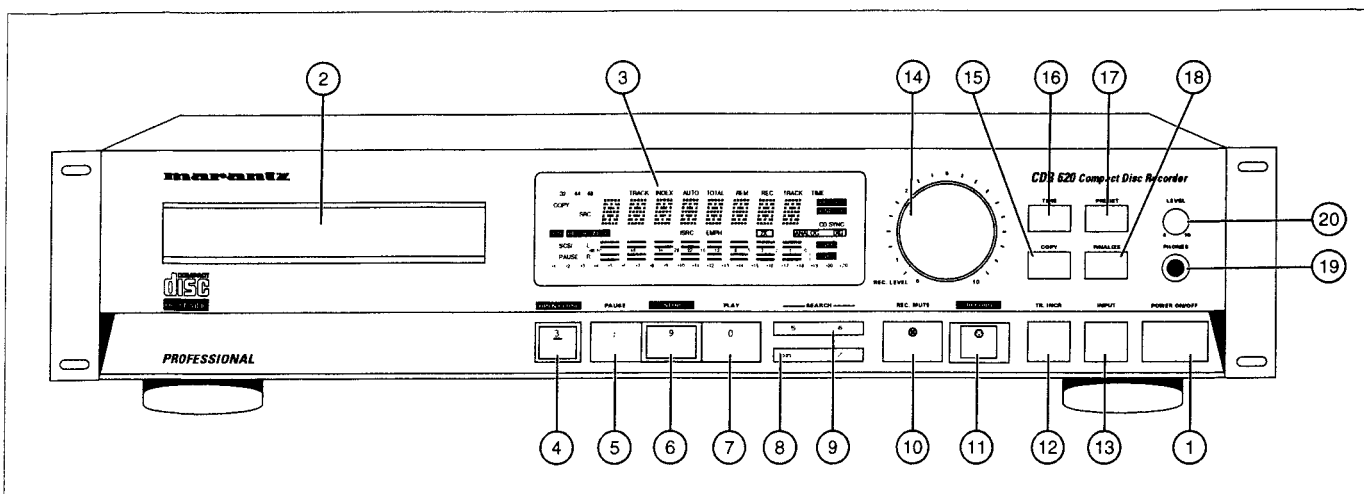

1. **POWER switch** to switch the recorder on/off
 2. **Disc tray** to insert a disc
 3. **Display**
 4. **OPEN/CLOSE button** to open and close the tray
 5. **PAUSE button** to temporarily interrupt recording or playback
 6. **STOP button**
To stop all functions.
In preset mode: stores preset values.
 7. **PLAY button**
To start playback or start recording from record-standby mode.
In playback the LED will light up green; in recording mode red; in rec-standby: blinking.
 8. **PREVIOUS and NEXT buttons**
For selecting a track to start playback with or selecting another track during playback.
In preset mode: changes preset value.
(see also PRESET)
 9. **SEARCH FORWARD and REVERSE buttons**
Fast search to a particular passage during playback.
 10. **REC MUTE button**
To record a pause at the beginning of a new track.
(see also PRESET)
 11. **RECORD**
To enter RECORD-STANDBY mode.
In ISRC-program mode: to store ISRC/UPC data.
 12. **TR.INCR. (TRACK INCREMENT)**
To manually record a new track number during recording
 13. **INPUT selector**
To select recording input; toggles between: XLR ANA, XLR DIG (**CDR620 ONLY**), COAX DIG.
 14. **REC LEVEL control**
To adjust the recording level of analogue left and right input channels.
 15. **COPY button (CDR620 ONLY)**
To initiate double speed copying between two CDR620 units via the SCSI-II interface.
 15. **MONITOR button (CDR615 ONLY)**
 16. **TIME button**
Selection of time display modes.
Toggles through: track-time, remaining track-time (playback), remaining total time (playback), remaining recording time.
 17. **PRESET button**
To change the recording default presets. Preset values can be changed with the PREVIOUS/NEXT keys and stored with the STOP button.
Using the preset key will toggle through the PRESET options:
 - Increment select: auto/manual
 - Auto-1
 - Audio delay time
 - Auto track level
 - Input sensitivity: +4/-10dBu
 - Rec Mute time
 - Digital Fade In on/off
 - Digital Fade In Time
 - Digital Fade Out on/off
 - Digital Fade Out Time
 - Cascade on/off (**CDR620 ONLY**)
 - FRONT/SCSI mode (**CDR620 ONLY**)
- IN SCSI MODE ALL KEYS WILL BE DISABLED EXCEPT THE PRESET, OPEN/CLOSE AND POWER ON/OFF KEYS.**
18. **FINALIZE**
To transform the CDR-disc in the final CD format. Table of contents (TOC) and lead-out will be recorded at double speed.
Press FINALIZE and then within 2 seconds RECORD.
 19. **PHONES connector**
Connector for standard stereo headphones.
 20. **Phones LEVEL**
To adjust the output level to the headphones.
- WHEN RC620 REMOTE CONTROL IS CONNECTED, THE FRONT PANEL CONTROL AND DISPLAY INDICATION OF CDR620 WILL BE TAKEN OVER BY THE REMOTE CONTROL RC620. THE DISPLAY OF CDR620 WILL INDICATE " REMOTE ".**

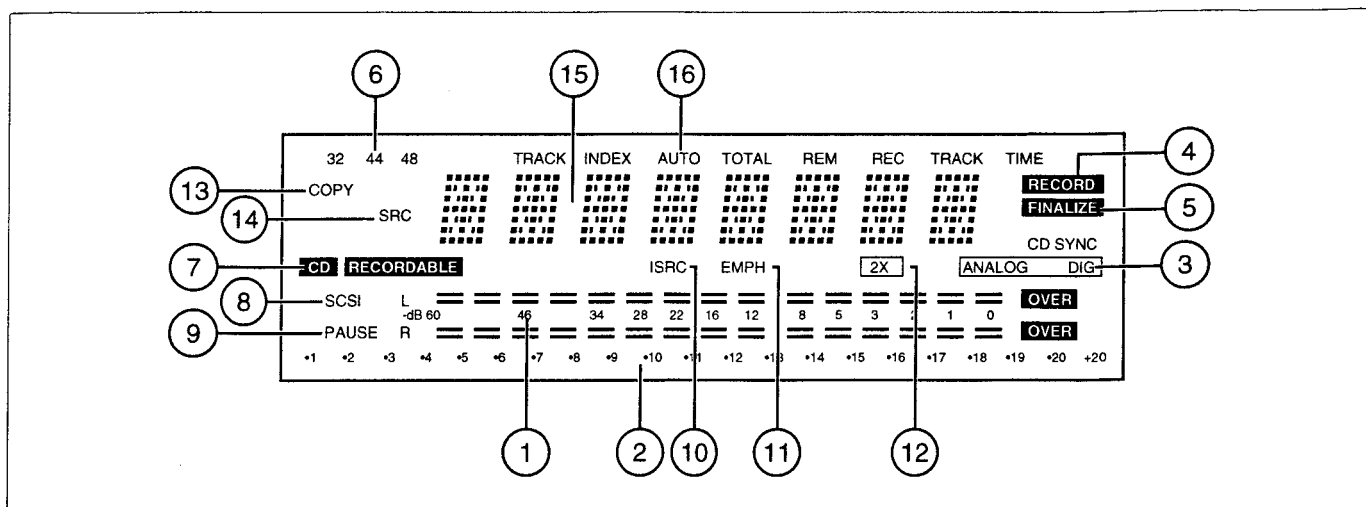

1. **Level meter**
Indication of audio level for recording and playback. Standard I/O level of +4/-10 dBu is shown at -12dB. OVER: at levels > -0,5 dB.
2. **Track Number indication**
Shows the number of tracks on the disc.
3. **ANALOGUE/DIG**
Indication of Analogue or Digital audio input selection.
4. **RECORD**
Recording indication. Blinking in rec-standby mode.
5. **FINALIZE**
Lights up when a disc is finalised.
6. **Sampling frequency indicators**
Displays the sampling frequency of the digital recording source. The indicator will show "44" when using the analogue input.
7. **CD RECORDABLE**
Indication of non-finalised CDR disc. Only "CD" will light up in case of prerecorded or finalised discs.
8. **SCSI (CDR620 ONLY)**
Will light up in SCSI mode.
9. **PAUSE**
10. **ISRC**
Will light up in ISRC/UPC mode (see RC620)
11. **EMPH**
Emphasis indication during recording or playback
12. **2X (CDR620 ONLY)**
Indication of double speed recording
13. **COPY**
Will light up when copy-bit is set (see RC620)
14. **SRC**
Indicates if sample-rate-converter is switched on
15. **Character display**
Indication of time, track number, index number and status messages of the unit
16. **AUTO**
Indicating auto-track-increment mode when recording CD-DA.

OPERATIONAL MODES

- In **STANDALONE** mode the CDR620 is a fully featured audio recorder designed for the creation/duplication of CD-DA titles.
- In **SCSI** mode and under control of a host computer, titles can be created in ALL CD-formats. **(CDR620 ONLY)**
- In **COPY** mode a double speed copy of Audio discs (CD-DA) can be made. **(CDR620 ONLY)**

REMOTE CONTROL OPERATION

CONTROL I/O : Parallel Input Terminals

The 9-pin CONTROL I/O connector on the rear panel has two functions:

- Output: sends logic level signals for PLAY, STOP and PAUSE.

When one of the front panel or wired remote controls is in use, the parallel remote connection will send a 500 msec pulse (5VDC, 50 mA max.)

- Input: receives logic level signals for PLAY, STOP, PAUSE, RECORD and TRACK INCREMENT.

Connect one of the input pins (1-5) to GND (pin 9) for 20 msec or more; closed contact operation.

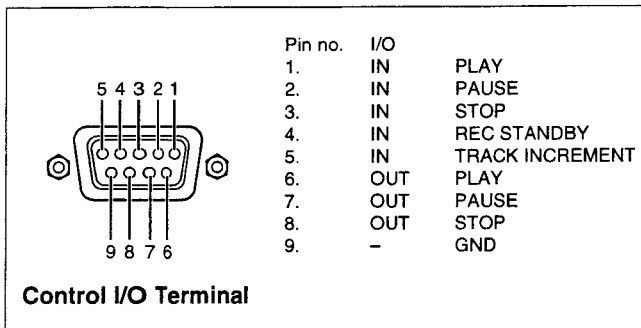

DIP-SWITCH SETTINGS: (CDR620 ONLY)

The switches are numbered 1,2,3,4 from left to right.

The dip-switches are OFF in upper position. Dip-switch 1 will switch the SCSI termination ON/OFF. When SCSI is used, switch 1 must be ON

Switch 2,3,4 determine the SCSI ADDRESS

DIP-SWITCH	2	3	4
ADDRESS 0	OFF	OFF	OFF
1	ON	OFF	OFF
2	OFF	ON	OFF
3	ON	ON	OFF
4	OFF	OFF	ON
5	ON	OFF	ON
6	OFF	ON	ON
7	ON	ON	ON

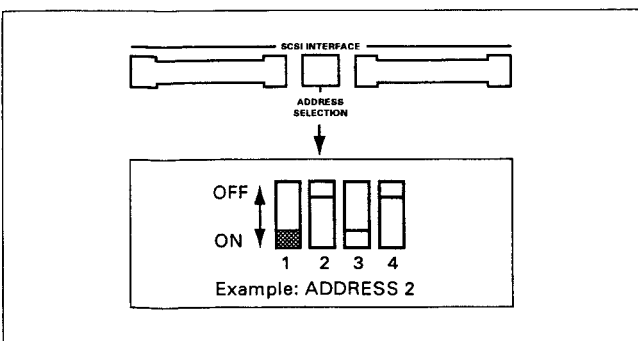

TROUBLE SHOOTING

The display will indicate system or user errors by error-number.

Error-number

Cause and Actions to be taken

02	no disc detected in the source at High Speed Copy - no disc inside / empty disc inside - replace disc
03	double speed setting failed - no empty disc in destination - insert empty CDR disc
04	OPC failed at destination at High Speed Copy - OPC area on the disc is full - replace disc
05	read error from source during copy process - bad or corrupt disc - replace disc
11	recovery failed - power off during finalizing - disc will be corrupted
21	general internal communication error - hardware/communication overflow - power off/on
22	general startup error - reading disc info failed - power off/on
23	general read/play error - power off/on
24	general write/record error - power off/on
25	general PMA error - power off/on
26	general OPC error - power off/on
29	mechanism/servo error - power off/on
99	general error condition at key input - give correct key input

1.3 TECHNICAL SPECIFICATIONS

1. GENERAL

1. Mains voltage	: 4 pos Voltage selector (100 / 120 / 230 /240)
2. Mains frequency	: 50 Hz/60Hz
3. Power consumption, operating	: approx. 30 Watt at normal voltage.
4. Monitoring	: Yes
5. Finalize	: speed n=2
6. Recording delay	:max. 3 sec. n=1 1Mb ram
7. Sample rate converter	:32 KHz ---> 50KHz
8. W/O sample rate converter	:44.1 KHz +/- 150ppm
9. copy	:high speed direct copy -Audio only -Track only.
10. copy control	: no (SCMS)
11. One time OPC	:max. number of disc : 10

2. AUDIO SPECIFICATIONS

2.1 BALANCED IN/OUT (monitor path)

1. Output voltage	Load impedance 600 ohm
a)input sens. +4 dBu	: +4 dBu (record level -12dB)
max. input +16dBu	: +16 dBu (record level max.)
max. input +24dBu	: +16 dBu (with adjust level)
b)input sens. -10dBu	: +4 dBu (record level -12dB)
max. input +2 dBu	: +16 dBu (record level max.)
max. input +24dBu	: +16 dBu (with adjust level)
c)Deviation	: All value within +/- 0.5 dBu
2. Unbalance	: max. 0.25 dB (typ. 0 dB)
3. Output Impedance	: 50 Ohm
4. Amplitude linearity	: max. +/- 0.5 dB (20Hz - 20KHz)
5. S/N - Ratio	: min. 90 dB : typ. 95 dB : min. 92 dB (A - wtg)
6. Dynamic range	: min. 86 dB (1 KHz) : typ. 88 dB (1 KHz) : min. 85 dB (20Hz - 20KHz)
7. THD + Noise	: min. 82 dB (20Hz - 20KHz) : typ. 85 dB (20Hz - 20KHz)
8. Out-band attenuation	: min. 55 dB above 25 KHz
9. Channel separation	: min. 90 dB (1 KHz) : typ. 100 dB (1KHz) : min. 85 dB (20Hz - 20KHz)
10.Muting during random	: min. 90 dB (BW = 20KHz) access
11.	:Phase linearity : typ. +/- 4.25 deg : max. +/- 4.85 deg (20Hz - 20KHz)
12.Low Level Linearity	: Max. +/- 5.5 dB (at -90 dB) : typ. +/- 2.5 dB (at -90 dB)

2.2 BALANCED ANALOG OUT Playback path only (CDR620 ONLY)

(measurements according to IEC 1096)

1. Output voltage (MAX.)	: +16 dBu /600 ohm load : 5.6 Vrms +/- 0.15 dB
2. Unbalance	: max. 0.2 dB
3. Output Impedance	: 200 ohm
4. Amplitude linearity	: max. +/- 0.2 dB (20Hz - 20KHz)
5. S/N - Ratio	: 100 dB
6. Dynamic range	: 92 dB (1 KHz)
7. THD + Noise	: min. 85 dB (20Hz - 20KHz) : typ. 90 dB (20Hz - 20KHz)
8. Out-band attenuation	: min. 55 dB above 25 KHz
9. Channel separation	: min. 90 dB (1 KHz) : typ. 100 dB 1KHz) : min. 85 dB (20Hz - 20KHz) : min. 100 dB with dig. silence kill
10.Muting during random	: min. 90 dB (BW = 20KHz) access
11.Phase linearity	: typ +/- 0.5 deg : max. +/- 0.6 deg (20Hz - 20KHz)
12 Low level linearity	: max. +/- 4 dB (at -90 dB) : typ. +/- 1.5 dB(at -90 dB)

2.3 BALANCED ANALOG IN ---> DIGITAL OUT BALANCED

1. Input sensitivity	: +4 dBu /- 10 dBu for max. level
a)inputsens. +4 dBu	: +4 dBu (record level -12dB)
max. input	: +16 dBu (record level max.)
max. input	: +24 dBu (with adjust level)
b)inputsens. -10dBu	: +4 dBu (record level -12dB)
max. input	: +2 dBu (record level max.)
max. input	: +24 dBu (with adjust level)
2. Unbalance	: max. 0.15 dB typ. 0 dB
3. Input Impedance	: 47 KOhm
4. Amplitude linearity	: max. +/- 0.15 dB (20Hz - 20KHz)
5. S/N - Ratio	: min. -92 dB : typ. -95 dB : min. -95 dB (A - wtg) : min. -90 dB (1 KHz)
6. Dynamic range	: typ. -93 dB (1 KHz) : min. -90 dB (20Hz - 20KHz)
7. THD + Noise	: min. -87 dB (1 KHz) : typ. -92 dB (1 KHz)
8. Out-band attenuation	: min. -60 dB above 25 KHz
9. Channel separation	: min. -90 dB (1 KHz) : typ. -100 dB (1KHz) : min. -87 dB (20Hz - 20KHz)
10.Phase linearity	: typ +/- 3.25 deg : max. +/- 3.85 deg (20Hz - 20KHz)
11 Low level linearity	: max. +/- 1.5 dB (at -90 dB) : typ. +/- 1 dB (at -90 dB)

2.4 HEADPHONE OUTPUT

(measurements according to IEC 1096)

1. Output voltage	: 0 to 6.5 Vrms +/- 2 dB (no load) : 0 to 5.42Vrms +/-2 dB (600 ohm load)
2. Output Impedance	: 120 ohm
3. Load impedance range	: 8, 32, 200, 600, 1000, 2000 ohm
4. Output power	: 0 - 58 mW into 32 ohm : 0 - 49 mW into 600 ohm : 0 - 88 mW into 120 ohm
5. Unbalance	: 2 dB
6. Phase linearity	: typ. +/- 0.225 deg. : max. +/- 0.35 deg (20Hz - 20KHz)
7. S/N Ratio	: typ. -93 dB load 600 ohm : min. -90 dB
8. Dynamic Range	: min. -90 dB (1KHz) load 500 ohm : min. -88 dB (20Hz - 20KHz)
9. THD + Noise	: min. -84 dB (1KHz) load 600 ohm
10.Channel separation	: min. -65 dB (20Hz - 20KHz) load 600 Ohm

1.4 WIRING DIAGRAM

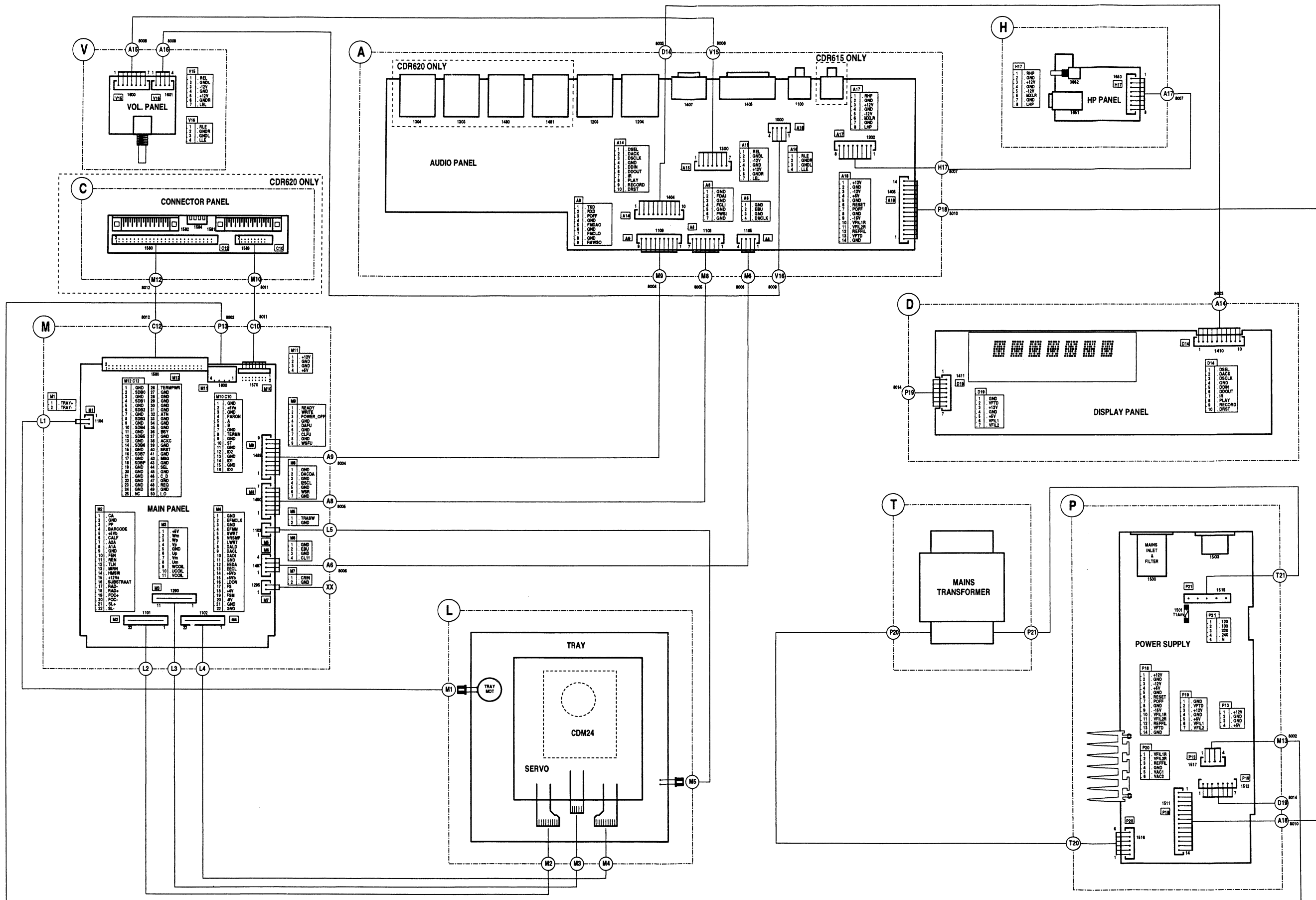

BLOCK DIAGRAM μ P/MONO PCB

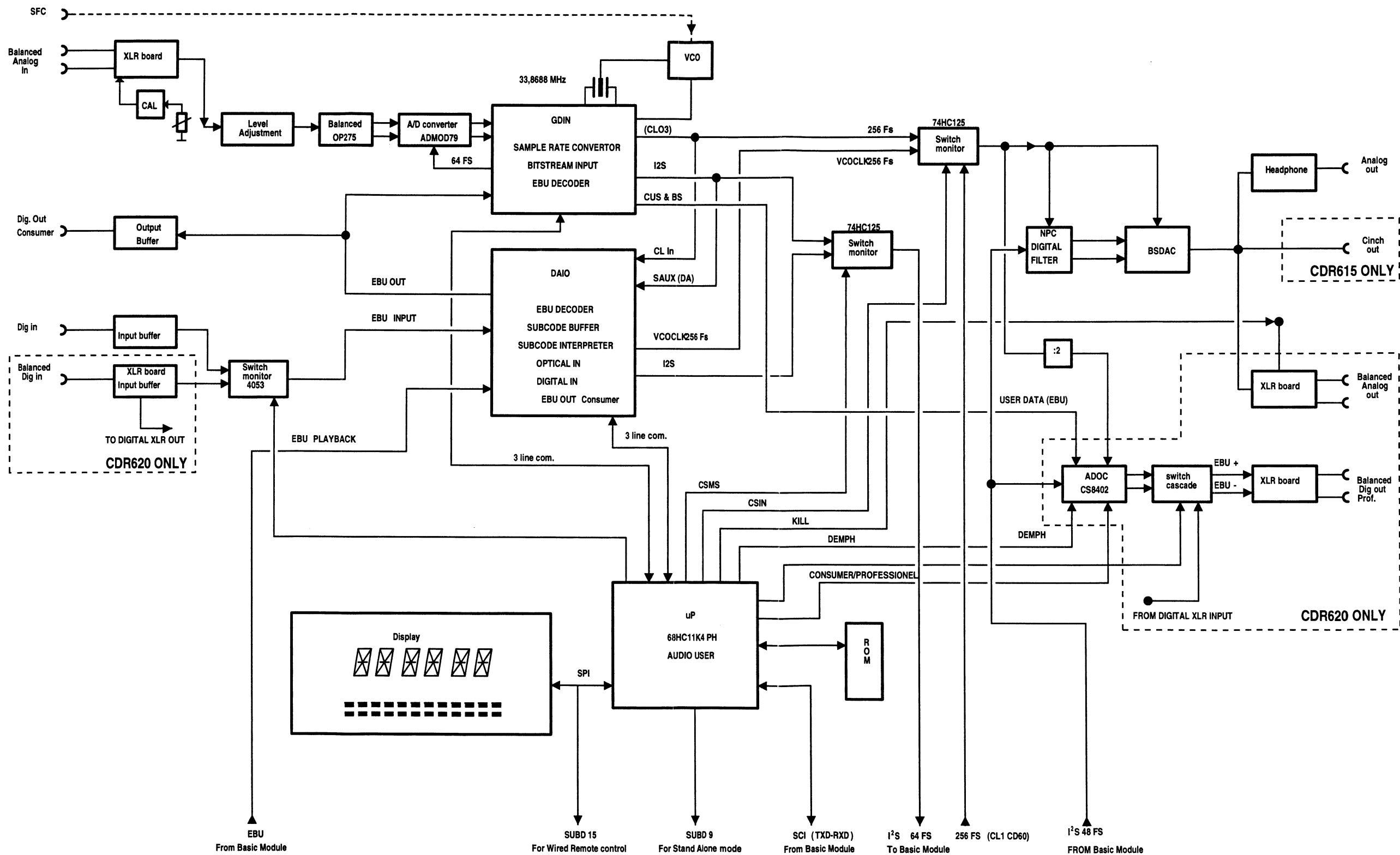

1.6 SCHEMATIC DIAGRAM AND PARTS LOCATION

BLOCK DIAGRAM DISPLAY PCB

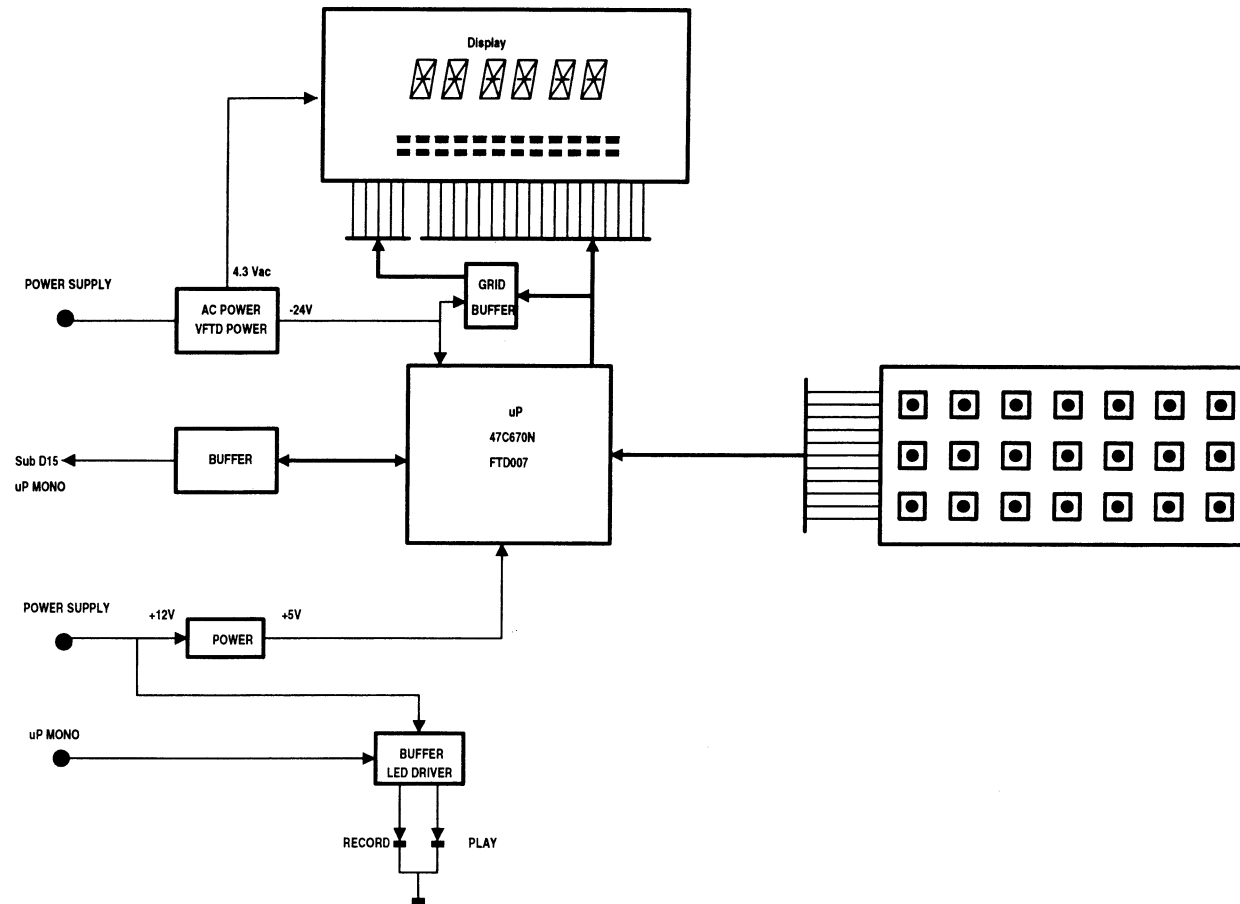

LEVEL

1600 A 1	1600 E 1	1601 C 7	2601 A 4	2605 E 3	3601 A 3	3605 D 4	3608 D 2	7600 A 5
1600 C 1	1600 B 1	1601 C 7	2602 A 1	2606 B 3	3602 C 3	3606 B 2	4601 A 4	7601 C 3
1600 B 1	1600 D 1	1601 D 7	2603 D 1	2607 E 3	3603 C 2	3607 E 2	4602 C 4	7601 C 5
1600 C 1	1601 B 7	2600 D 4	2604 B 3	3600 A 2	3604 B 4	3608 A 2	7600 A 3	

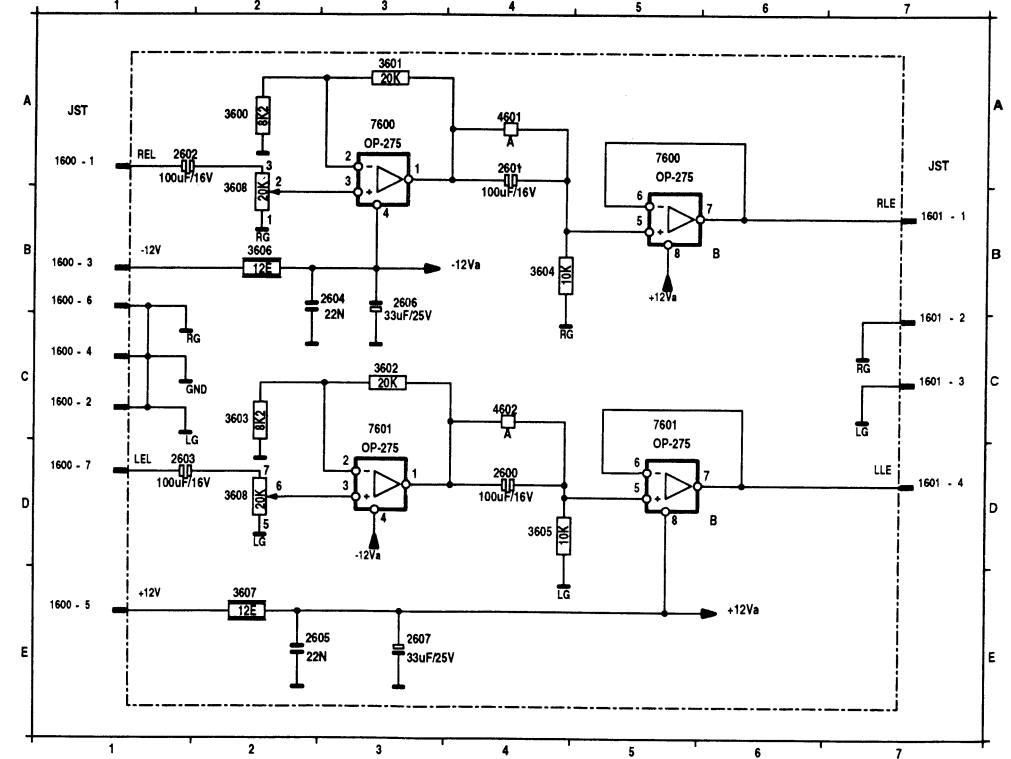

1.6 SCHEMATIC DIAGRAM AND PARTS LOCATION

LEVEL

1600 A 1	1600 E 1	1601 C 7	2601 A 4	2605 E 3	3601 A 3	3605 D 4	3608 D 2	7600 A 5
1600 C 1	1600 B 1	1601 C 7	2602 A 1	2606 B 3	3602 C 3	3606 B 2	4601 A 4	7601 C 3
1600 B 1	1600 D 1	1601 D 7	2603 D 1	2607 E 3	3603 C 2	3607 E 2	4602 C 4	7601 C 5
1600 C 1	1601 B 7	2600 D 4	2604 B 3	3600 A 2	3604 B 4	3608 A 2	7600 A 3	

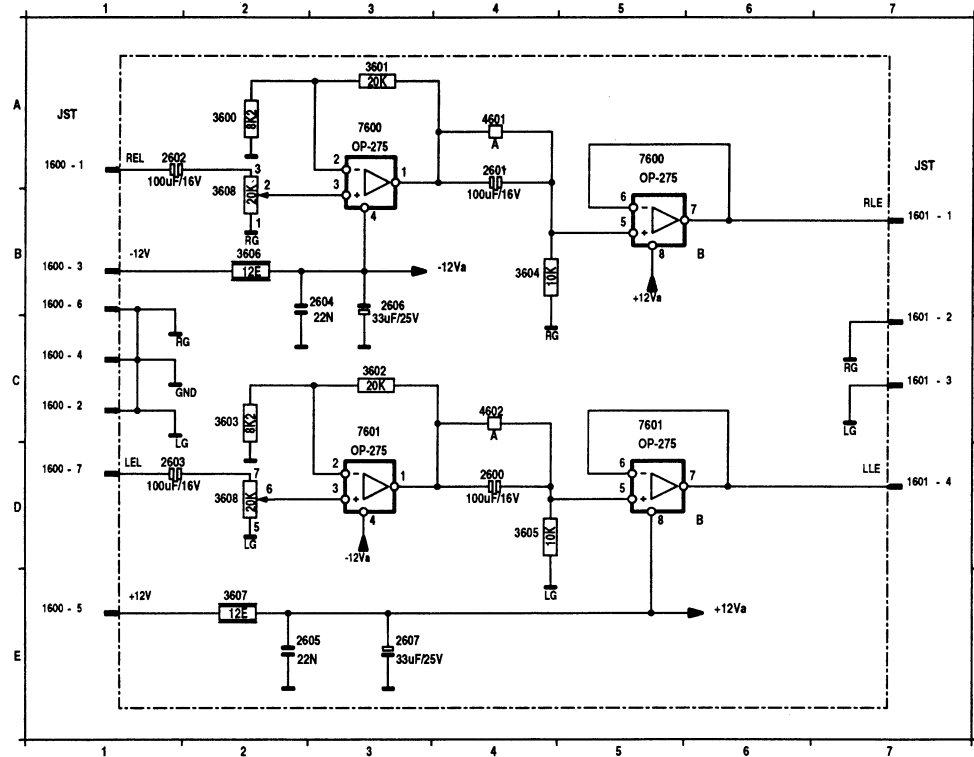

LEVEL BOARD

COMPONENT SIDE

1600 A 5	2600 C 3	2602 A 4	2606 A 4	3608 B 3	9060 B 4	9062 B 5
1601 C 5	2601 A 3	2603 C 4	2607 B 4	9059 A 4	9061 B 5	9063 C 5

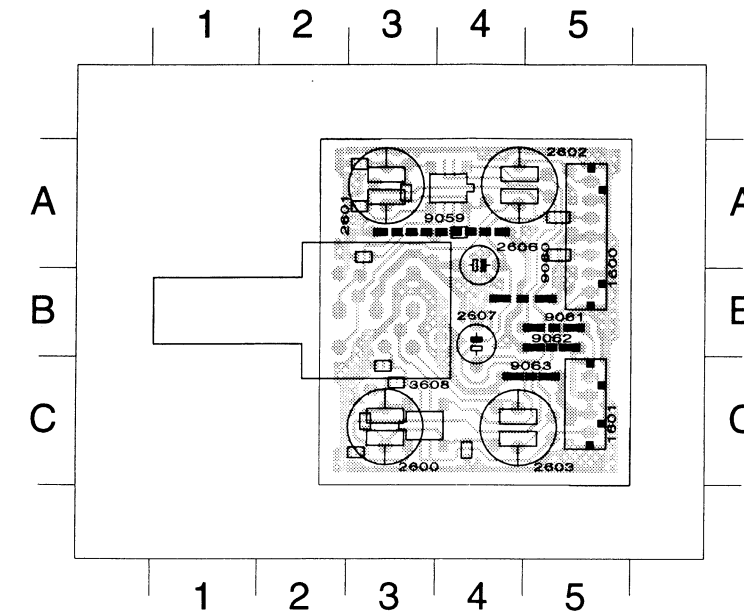

SOLDER SIDE

2604 A 3	3600 A 3	3602 C 3	3604 A 3	3606 A 5	4601 A 3	7600 A 4
2605 C 3	3601 A 4	3603 C 3	3605 C 4	3607 A 5	4602 C 3	7601 C 3

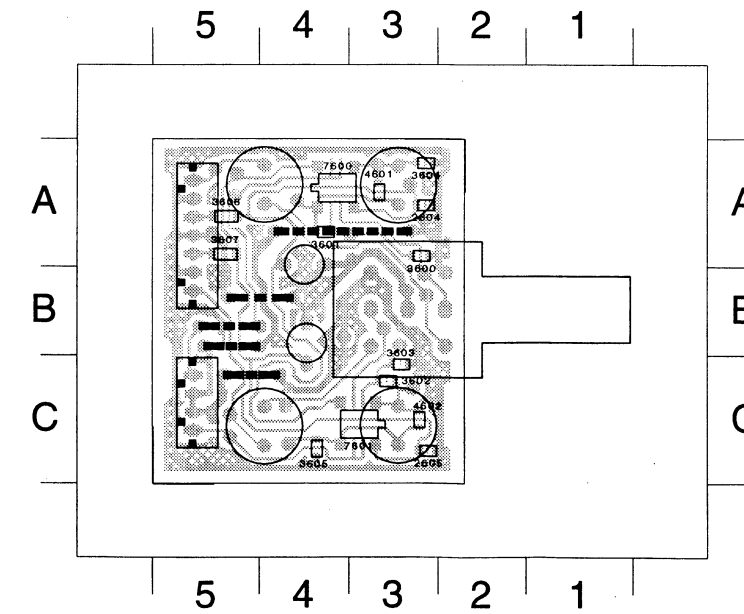

AUDIO INPUT PART

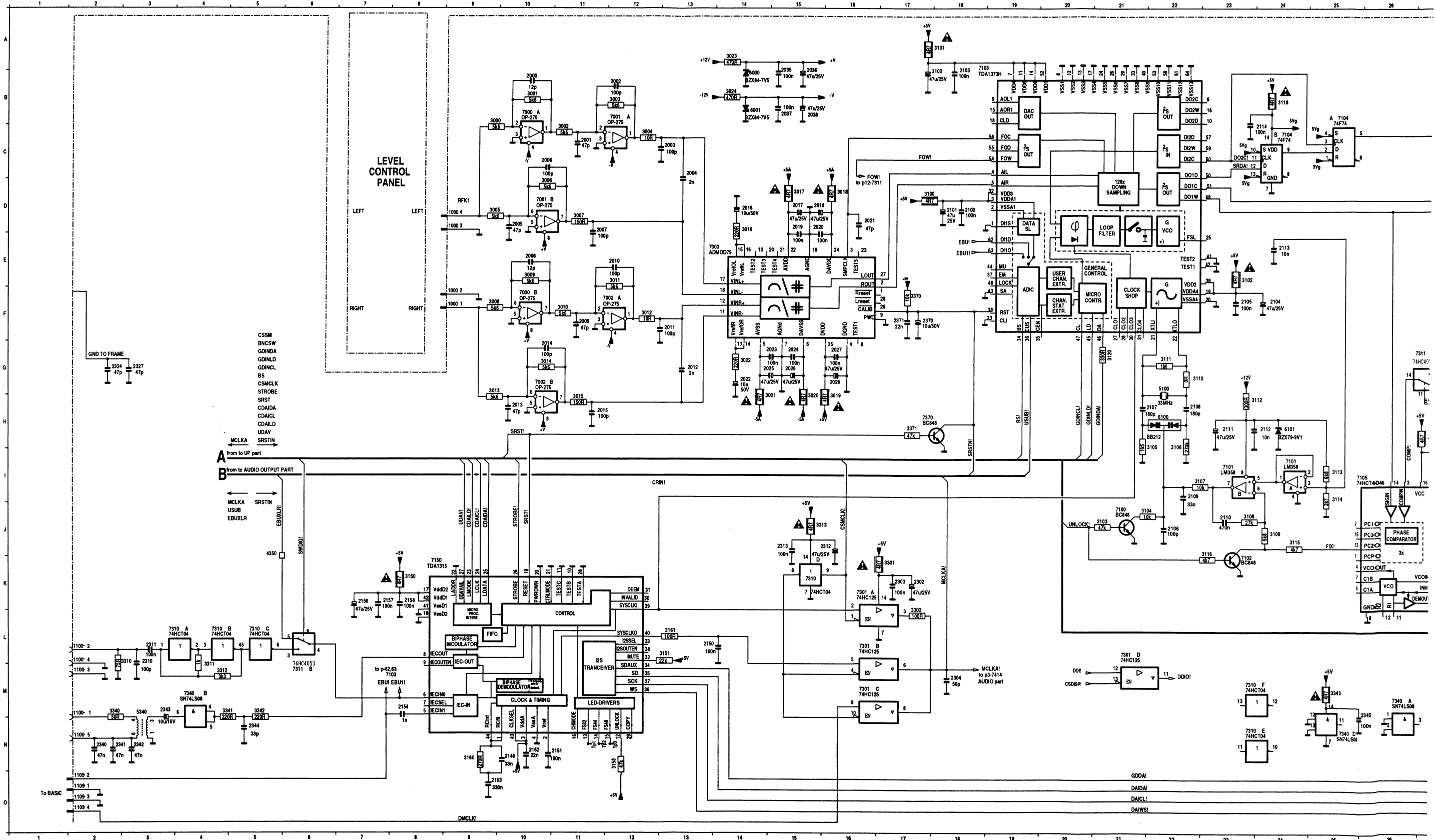

AUDIO OUTPUT PART

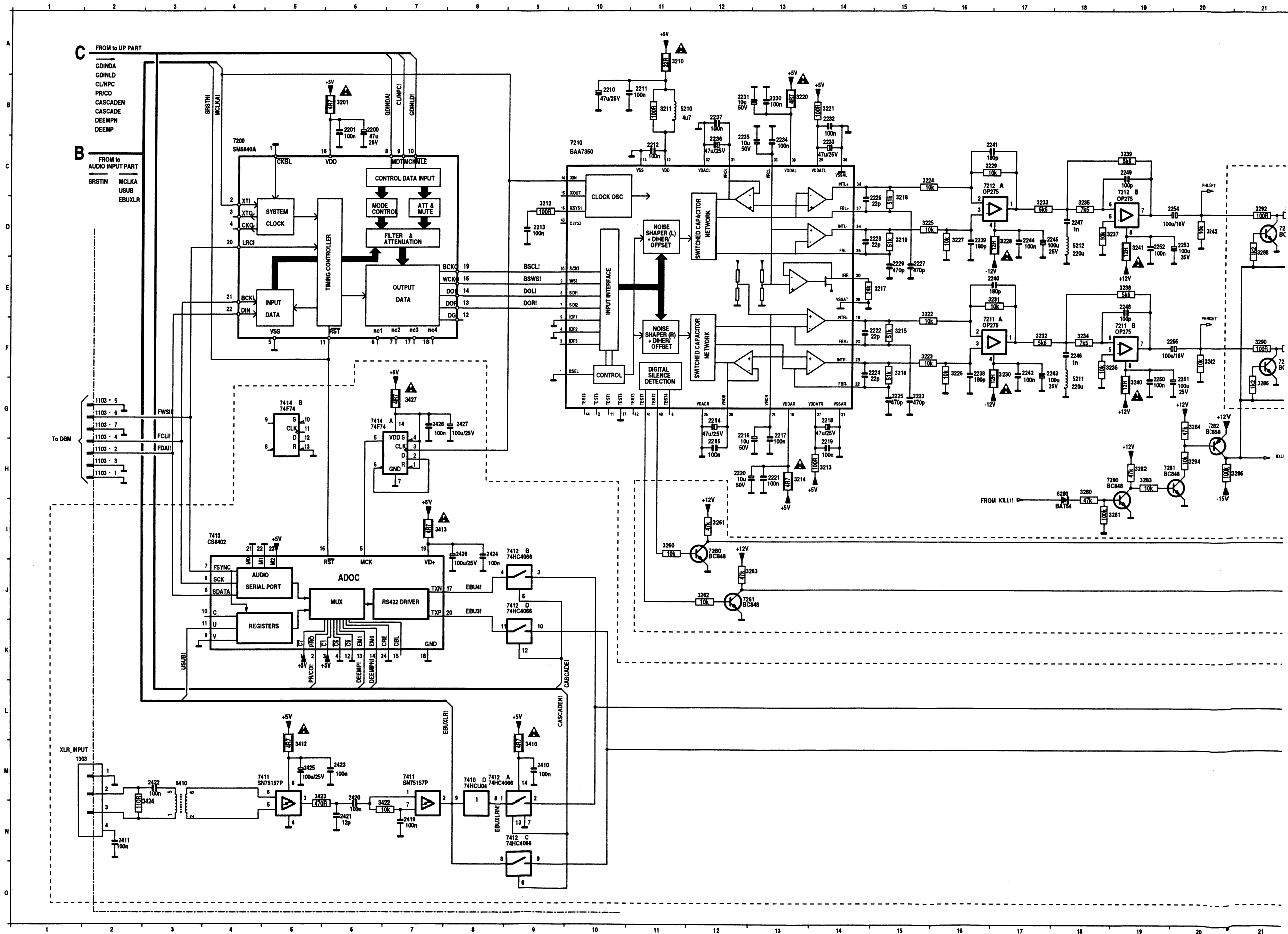

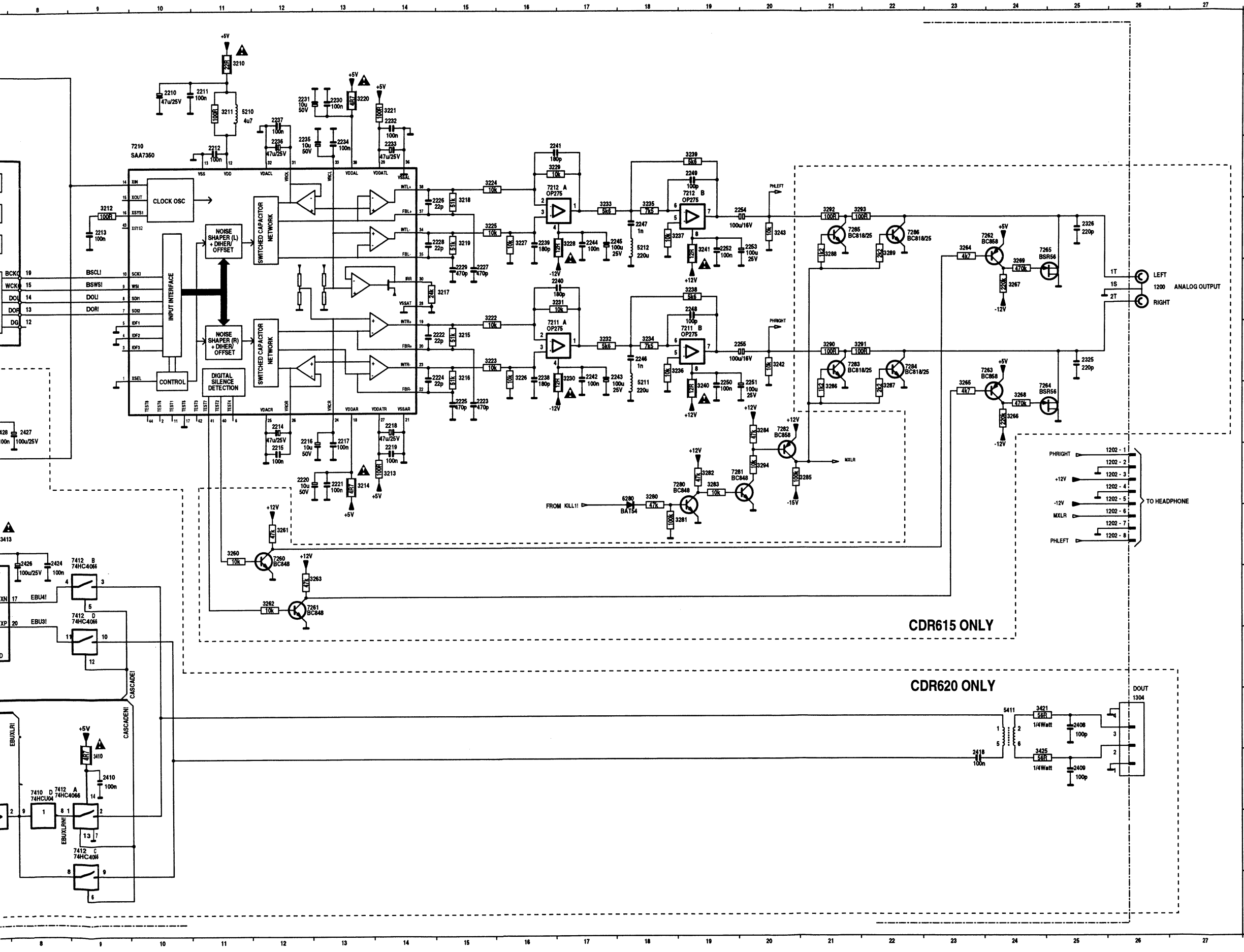

1103 H 2	7211 F10
1103 H 2	7212 C16
1103 H 2	7212 C19
1103 G 2	7260 J12
1103 G 2	7261 J12
1103 G 2	7262 D23
1103 G 2	7263 F23
1200 E26	7264 G24
1202 H25	7265 D24
1202 H25	7266 H18
1202 H25	7267 H19
1202 H25	7268 G20
1202 H25	7269 F21
1202 G26	7284 F22
1202 J26	7285 D21
1202 J26	7286 D22
1202 J26	7410 M 6
1303 M 2	7411 M 7
1304 M26	7411 M 4
2200 E 6	7411 M 7
2201 B 6	7412 M 8
2210 B10	7412 J 9
2211 B11	7412 J 9
2212 B11	7413 J 4
2213 D 9	7413 J 4
2214 G12	7414 G 6
2215 H12	7414 G 6
2216 G12	
2217 G13	
2218 G14	
2219 H14	
2220 H12	
2221 H13	
2222 F15	
2223 D15	
2224 F15	
2225 G15	
2226 C15	
2227 E15	
2228 D15	
2229 E15	
2230 B13	
2231 B12	
2232 B14	
2233 C14	
2234 C13	
2235 B12	
2236 C12	
2237 B12	
2238 F16	
2239 D18	
2240 E17	
2241 C17	
2242 F17	
2243 F18	
2244 D17	
2245 D18	
2246 F18	
2247 D18	
2248 E19	
2249 C19	
2250 G19	
2251 G20	
2252 D19	
2253 D20	
2254 D20	
2255 F20	
2255 F20	
2256 F20	
2257 G20	
2408 L25	
2409 M25	
2410 M 2	
2411 N 2	
2418 M24	
2419 J 7	
2420 M 6	
2421 M 6	
2422 M 3	
2423 M 5	
2424 B 8	
2425 E 6	
2426 I 8	
2427 G 8	
2428 G 7	
3201 B 6	
3210 A11	
3211 B11	
3212 D 9	
3213 H14	
3214 H13	
3215 F15	
3216 F15	
3217 E15	
3218 C15	
3219 D15	
3220 B13	
3221 B14	
3222 E15	
3223 E15	
3224 C15	
3225 D15	
3226 F16	
3227 D16	
3228 D17	
3229 C17	
3230 F17	
3231 E17	
3232 F17	
3233 D17	
3234 F18	
3235 D18	
3236 F19	
3237 D19	
3238 E19	
3239 C19	
3240 G19	
3241 D19	
3242 F20	
3243 D20	
3260 I11	
3261 I12	
3262 J12	
3263 J13	
3264 D23	
3265 G23	
3266 G24	
3267 E24	
3268 G24	
3269 E24	
3280 H18	
3281 H19	
3282 H19	
3283 H19	
3284 G20	
3285 M21	
3286 D21	
3288 D22	
3290 F20	
3291 F22	
3292 D20	
3293 D22	
3294 H20	
3410 M 9	
3412 M 5	
3413 I 7	
3421 L25	
3422 N 7	
3423 M 2	
3424 M 2	
3425 M25	
3427 G 7	
5210 B11	
5211 G18	
5212 D18	
5410 M 3	
5411 M24	
6280 H18	
7200 E 4	
7210 C10	
7211 F16	

UP PART

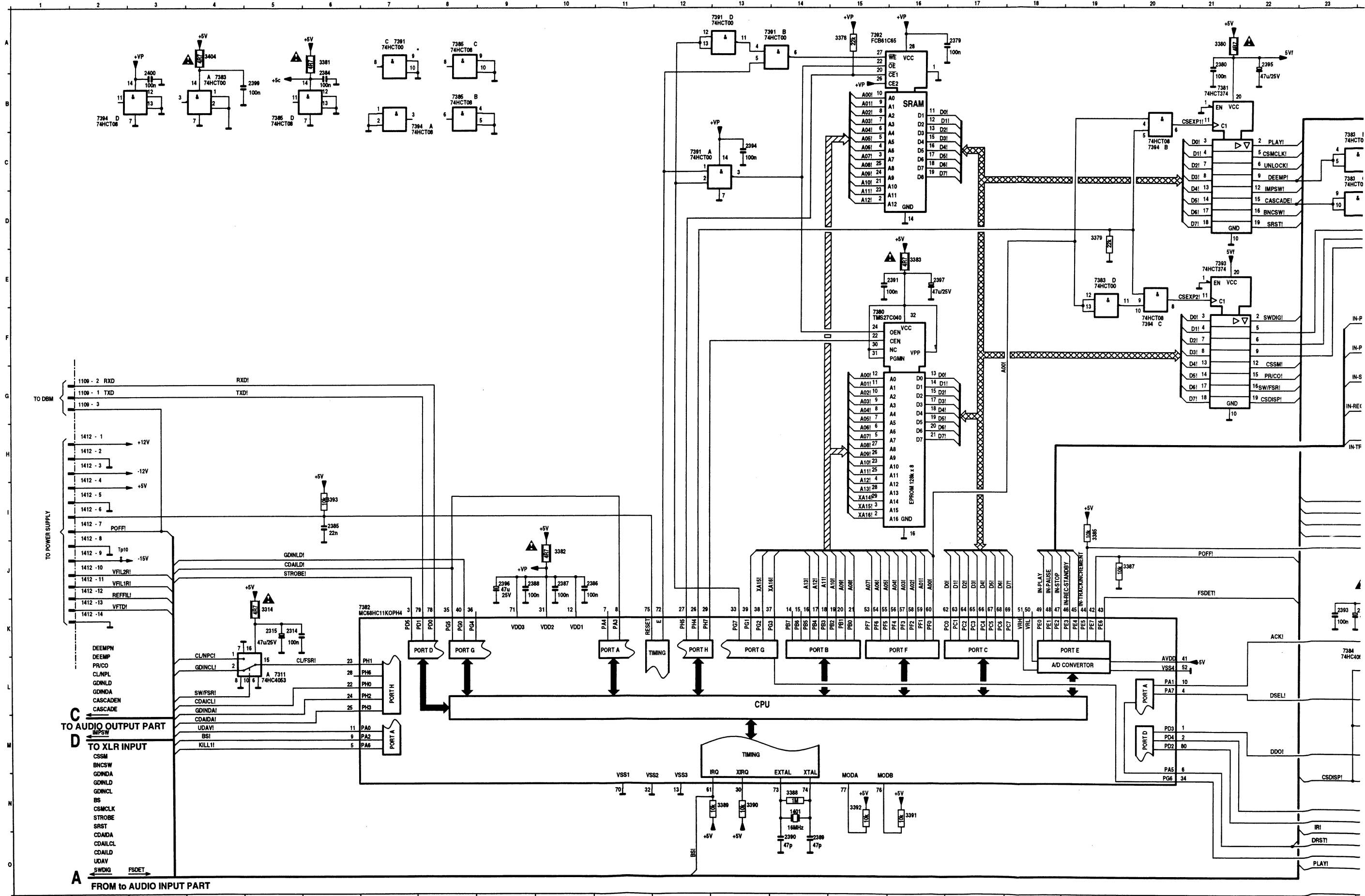

XLR INPUT PART

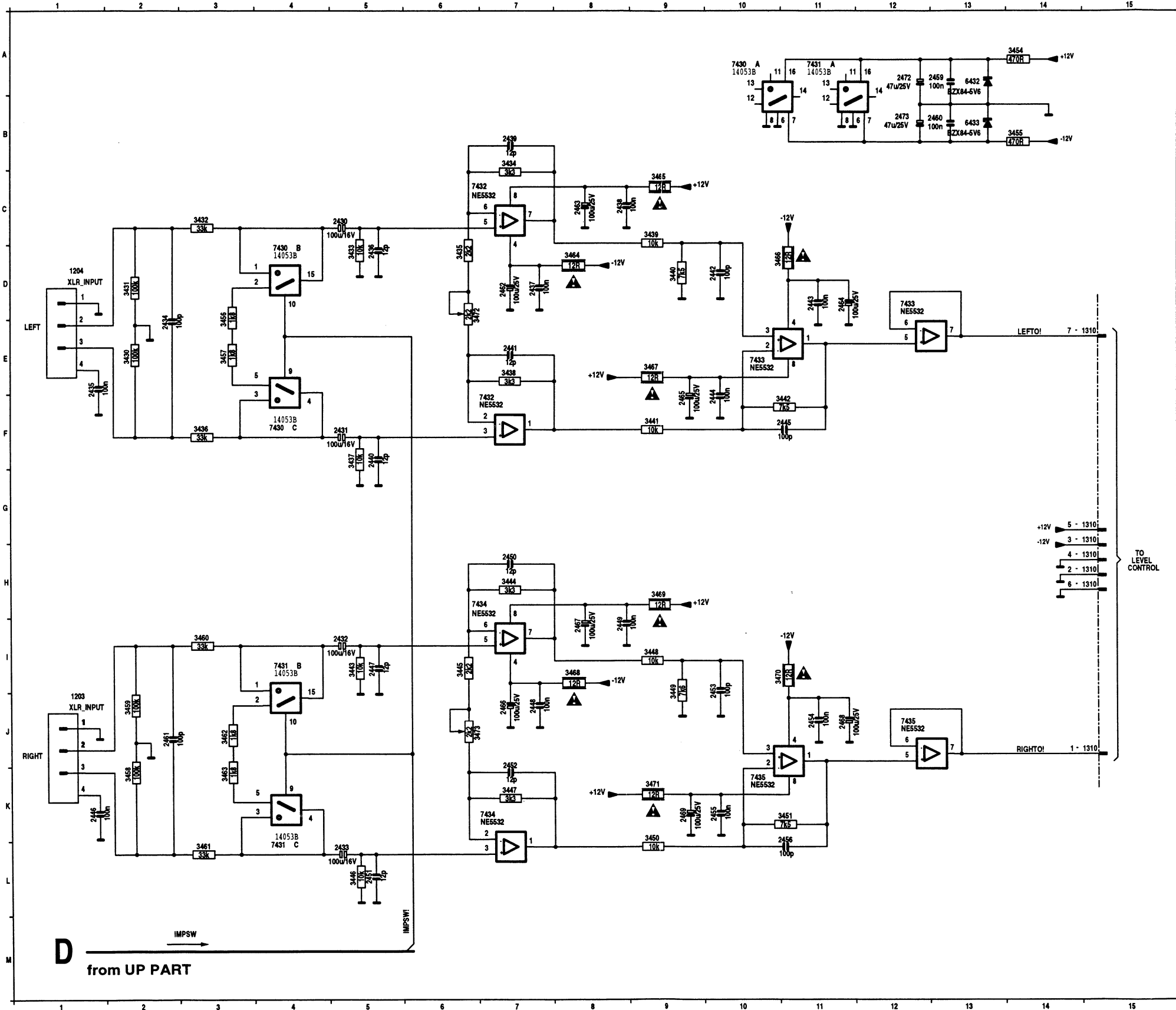

- 1200 J 1
- 1204 D 1
- 1310 H15
- 1310 H15
- 1310 H15
- 1310 H15
- 1310 H15
- 2430 C 5
- 2431 F 5
- 2432 L 5
- 2433 L 5
- 2434 E 2
- 2435 E 5
- 2436 D 5
- 2437 D 7
- 2438 C 8
- 2439 B 7
- 2440 F 5
- 2441 E 7
- 2442 D10
- 2443 D11
- 2444 F10
- 2445 F11
- 2446 K 1
- 2447 I 5
- 2448 J 7
- 2449 I 8
- 2450 H 7
- 2451 L 5
- 2452 K 7
- 2453 I10
- 2454 J11
- 2455 K10
- 2456 L11
- 2459 A13
- 2460 B13
- 2461 J 2
- 2462 D 2
- 2463 C 8
- 2464 D11
- 2465 F 11
- 2466 J 7
- 2467 I 8
- 2468 J11
- 2469 K 9
- 2472 A12
- 2473 B12
- 2474 E 2
- 3431 D 2
- 3432 C 3
- 3433 C 3
- 3434 B 7
- 3435 D 6
- 3436 F 9
- 3437 F 5
- 3438 E 7
- 3439 C 9
- 3440 D 9
- 3441 F 9
- 3442 F11
- 3443 I 5
- 3444 H 7
- 3445 I 6
- 3446 L 5
- 3447 K 7
- 3448 I 9
- 3449 I 9
- 3450 K 9
- 3451 K11
- 3454 A14
- 3455 B14
- 3456 D 3
- 3457 E 3
- 3458 K 2
- 3459 J 2
- 3460 I 3
- 3461 L 3
- 3462 J 3
- 3463 K 3
- 3464 D 8
- 3465 C 9
- 3466 D11
- 3467 E 9
- 3468 I 9
- 3469 H 9
- 3470 I11
- 3471 K 9
- 3472 D 7
- 3473 J 7
- 6432 A13
- 6433 B13
- 7430 A10
- 7430 D 4
- 7430 F 4
- 7431 A11
- 7431 I 4
- 7431 K 4
- 7432 F 7
- 7432 C 6
- 7433 E10
- 7433 D12
- 7434 K 7
- 7434 H 6
- 7435 K10
- 7435 J12

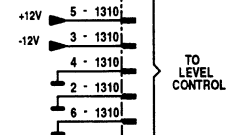

D from UP PART

XLR OUTPUT PART (CDR620 ONLY)

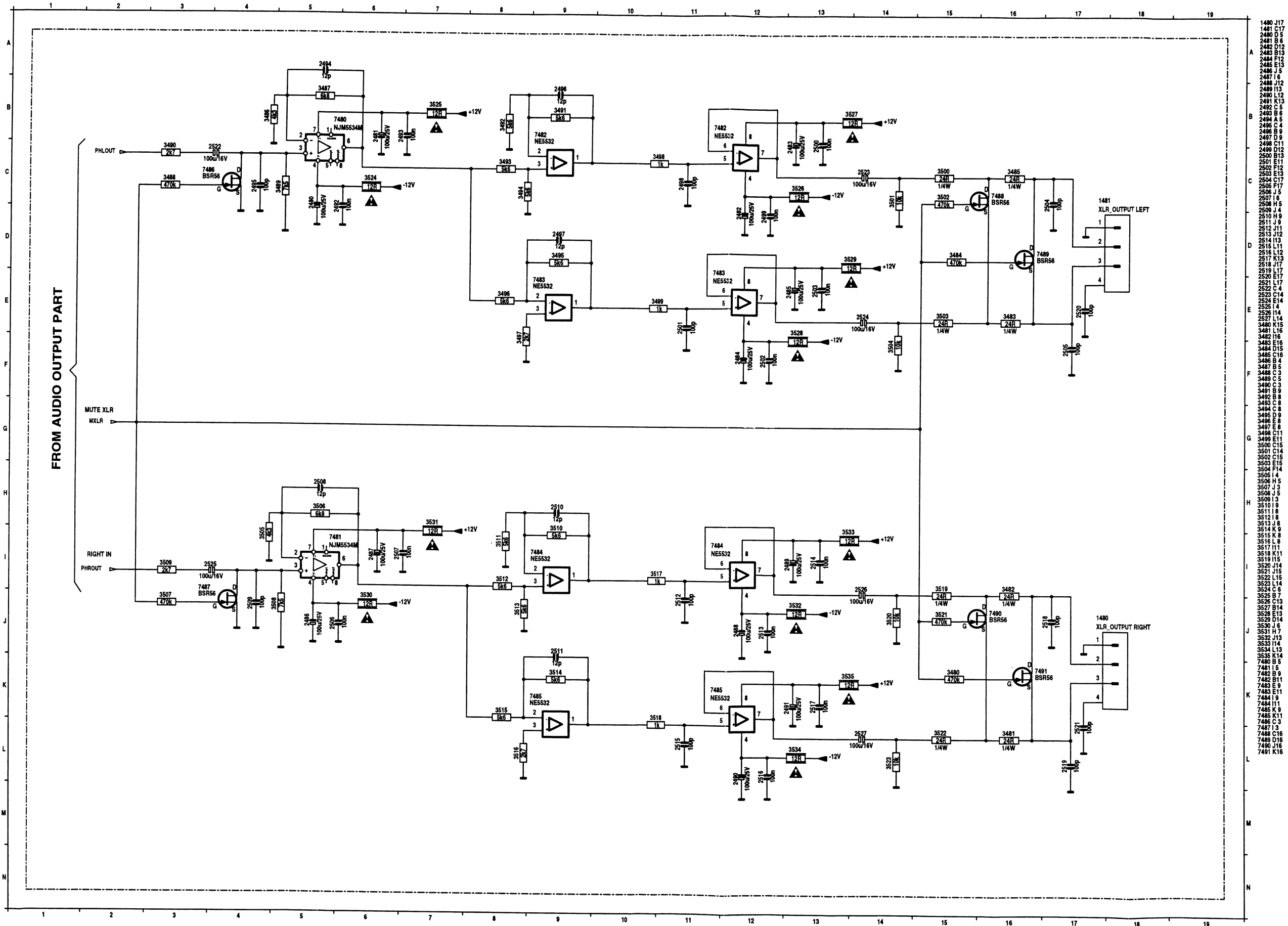

- 1480 J17
- 1481 C17
- 2480 D5
- 2481 B6
- 2482 D12
- 2483 B13
- 2484 F12
- 2485 E13
- 2486 J5
- 2487 I6
- 2488 J12
- 2489 I13
- 2490 L12
- 2491 K13
- 2492 C5
- 2493 B6
- 2494 A5
- 2495 C4
- 2496 B9
- 2497 D9
- 2498 C11
- 2499 D12
- 2500 B13
- 2501 E11
- 2502 F12
- 2503 E13
- 2504 C17
- 2505 F17
- 2506 C14
- 2507 I6
- 2508 H5
- 2509 J9
- 2510 H9
- 2511 J9
- 2512 J11
- 2513 J12
- 2514 I13
- 2515 L11
- 2516 L12
- 2517 K13
- 2518 J17
- 2519 E17
- 2520 E17
- 2521 L17
- 2522 C4
- 2523 C14
- 2524 E14
- 2525 A4
- 2526 I14
- 2527 L14
- 3480 K15
- 3481 L16
- 3482 I16
- 3483 E16
- 3484 D15
- 3485 C15
- 3486 B4
- 3487 B5
- 3488 C5
- 3489 C5
- 3490 C3
- 3491 B9
- 3492 B9
- 3493 C8
- 3494 C8
- 3495 D8
- 3496 E8
- 3497 E8
- 3498 C11
- 3499 E11
- 3500 C15
- 3501 C14
- 3502 C14
- 3503 E15
- 3504 F14
- 3505 I4
- 3506 H5
- 3507 J3
- 3508 J5
- 3509 I6
- 3510 I9
- 3511 I8
- 3512 I8
- 3513 J8
- 3514 K9
- 3515 K8
- 3516 L8
- 3517 I11
- 3518 K11
- 3519 I15
- 3520 J14
- 3521 J15
- 3522 L15
- 3523 L14
- 3524 C6
- 3525 B7
- 3526 C13
- 3527 B14
- 3528 E13
- 3529 D14
- 3530 J6
- 3531 H7
- 3532 I13
- 3533 I14
- 3534 L13
- 3535 K14
- 7480 B5
- 7481 I5
- 7482 B9
- 7483 E11
- 7484 I11
- 7485 K9
- 7486 C3
- 7487 I3
- 7488 C16
- 7489 D15
- 7490 J16
- 7491 K16

SCSI INTERFACE (CDR620 ONLY)

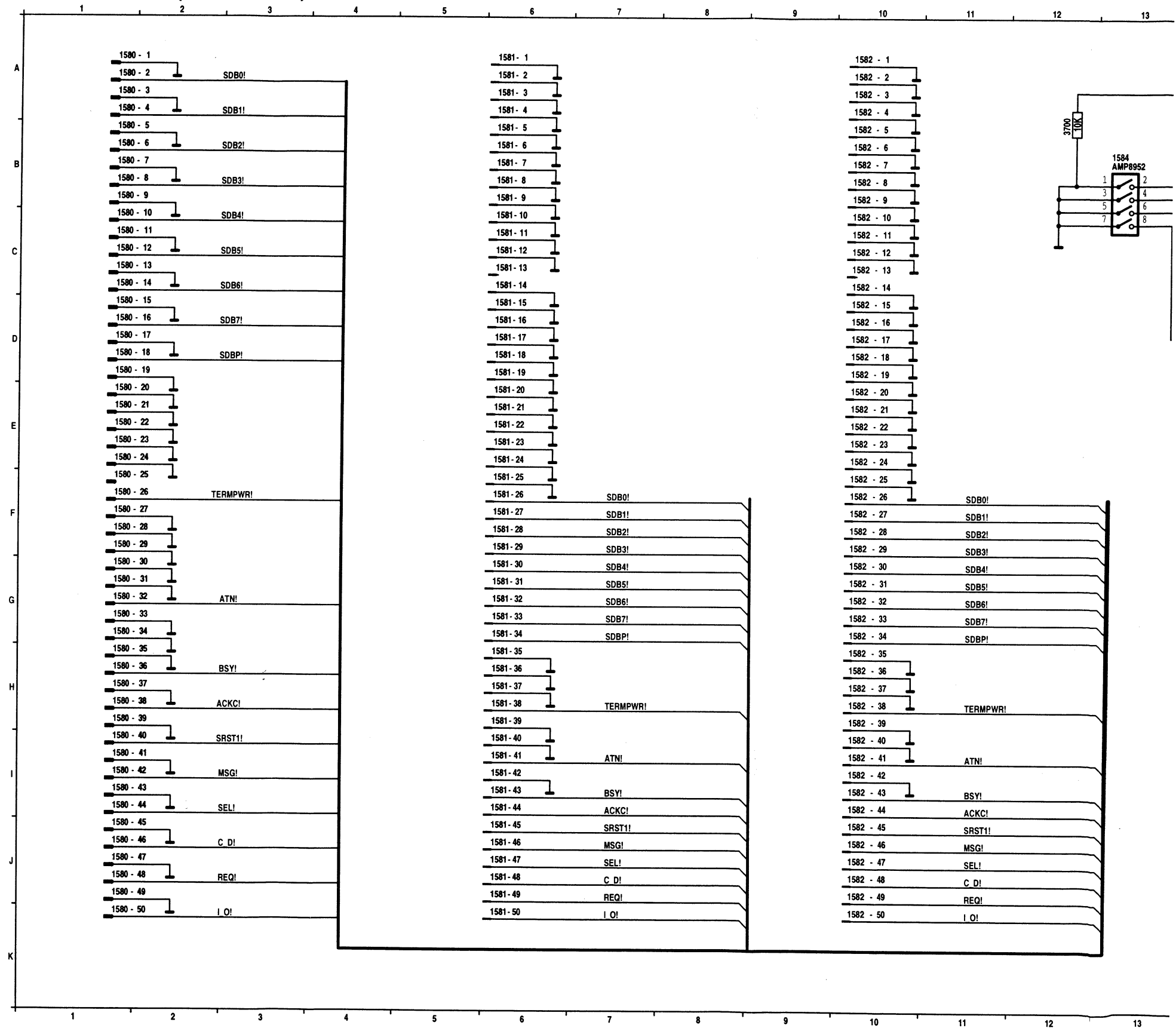

CDR620 ONLY)

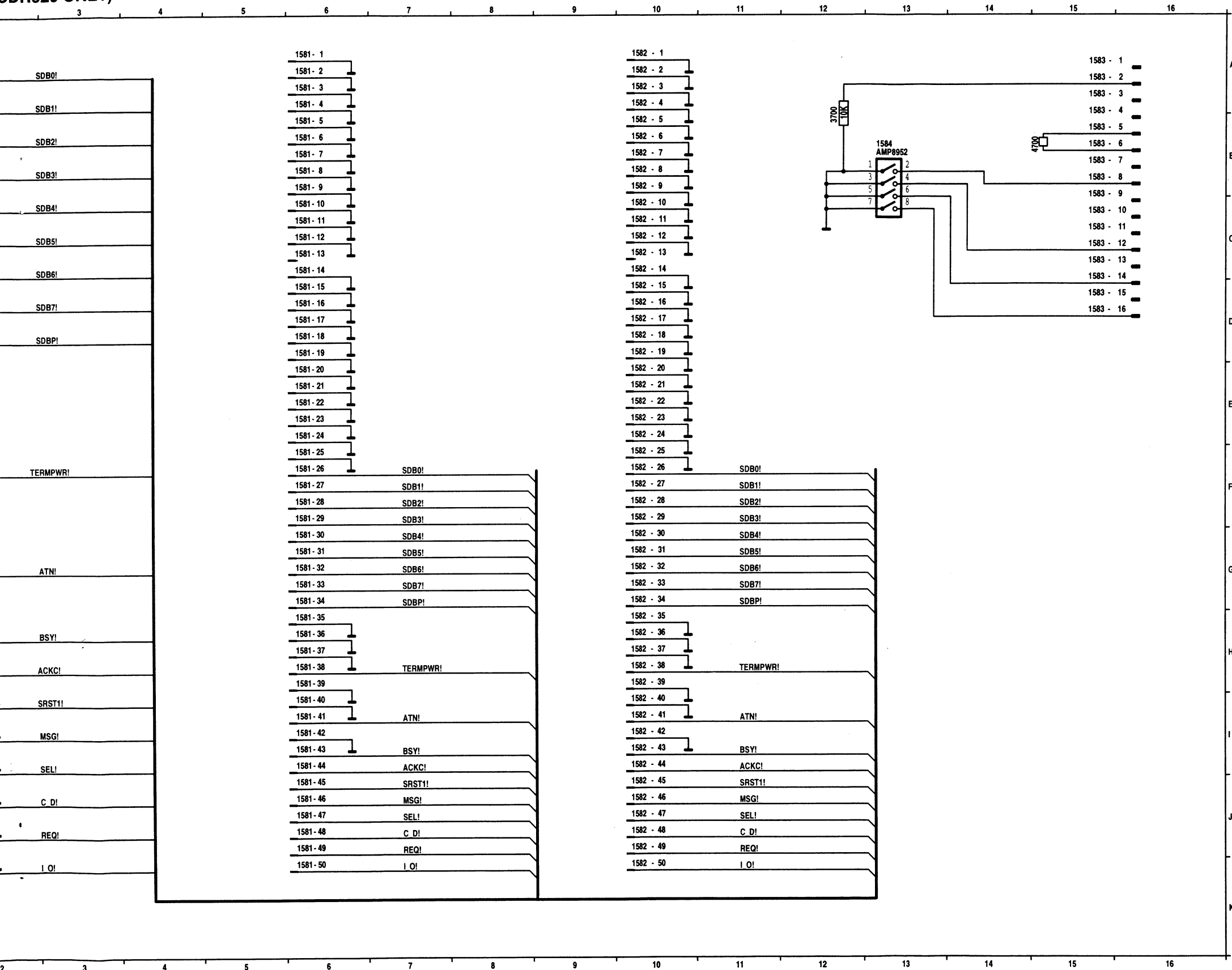

- 1580 A 1
- 1580 A 1
- 1580 A 1
- 1580 A 1
- 1580 A 1
- 1580 B 1
- 1580 B 1
- 1580 B 1
- 1580 B 1
- 1580 C 1
- 1580 C 1
- 1580 C 1
- 1580 C 1
- 1580 D 1
- 1580 D 1
- 1580 D 1
- 1580 D 1
- 1580 E 1
- 1580 E 1
- 1580 E 1
- 1580 E 1
- 1580 F 1
- 1580 F 1
- 1580 F 1
- 1580 F 1
- 1580 G 1
- 1580 G 1
- 1580 G 1
- 1580 G 1
- 1580 H 1
- 1580 H 1
- 1580 H 1
- 1580 H 1
- 1580 I 1
- 1580 I 1
- 1580 I 1
- 1580 I 1
- 1580 J 1
- 1580 J 1
- 1580 J 1
- 1580 J 1
- 1580 K 1
- 1581 A 6
- 1581 A 6
- 1581 A 6
- 1581 A 6
- 1581 B 6
- 1581 B 6
- 1581 B 6
- 1581 B 6
- 1581 C 6
- 1581 C 6
- 1581 C 6
- 1581 C 6
- 1581 D 6
- 1581 D 6
- 1581 D 6
- 1581 D 6
- 1581 E 6
- 1581 E 6
- 1581 E 6
- 1581 E 6
- 1581 F 6
- 1581 F 6
- 1581 F 6
- 1581 F 6
- 1581 G 6
- 1581 G 6
- 1581 G 6
- 1581 G 6
- 1581 H 6
- 1581 H 6
- 1581 H 6
- 1581 H 6
- 1581 I 6
- 1581 I 6
- 1581 I 6
- 1581 I 6
- 1581 J 6
- 1581 J 6
- 1581 J 6
- 1581 J 6
- 1581 K 6
- 1582 A 10
- 1582 A 10
- 1582 A 10
- 1582 A 10
- 1582 B 10
- 1582 B 10
- 1582 B 10
- 1582 B 10
- 1582 C 10
- 1582 C 10
- 1582 C 10
- 1582 C 10
- 1582 D 10
- 1582 D 10
- 1582 D 10
- 1582 D 10
- 1582 E 10
- 1582 E 10
- 1582 E 10
- 1582 E 10
- 1582 F 10
- 1582 F 10
- 1582 F 10
- 1582 F 10
- 1582 G 10
- 1582 G 10
- 1582 G 10
- 1582 G 10
- 1582 H 10
- 1582 H 10
- 1582 H 10
- 1582 H 10
- 1582 I 10
- 1582 I 10
- 1582 I 10
- 1582 I 10
- 1582 J 10
- 1582 J 10
- 1582 J 10
- 1582 J 10
- 1582 K 10

COMPONENT SIDE

1000 A 8	1204 A 5	1404 C 5	2013 A 8	2032 B 7	2102 C 8	2201 C 9	2236 C 9	2254 A 9	2344 C 7	2396 C 4	2430 A 6	2467 A 5	2484 B 4	2523 A 3	3017 B 7	3119 C 9	3161 C 7	3268 A 9	3295 C 5	3381 B 6	3425 A 1	3482 A 2	4101 C 9	5411 A
1100 A 8	1300 B 9	1405 A 7	2016 B 7	2034 B 7	2104 C 8	2210 C 9	2242 B 9	2255 A 9	2350 A 7	2397 B 4	2431 A 6	2468 B 5	2485 B 3	2524 A 3	3018 B 7	3120 C 8	3228 B 9	3269 A 9	3302 C 8	3382 C 4	3432 A 6	3483 A 4	4500 C 7	6100 C
1103 C 6	1303 A 2	1407 A 6	2017 B 7	2036 A 7	2110 C 9	2214 C 9	2243 B 9	2300 C 5	2351 A 7	2398 C 5	2432 A 5	2469 B 5	2486 B 2	2525 C 2	3019 C 8	3153 C 7	3230 B 9	3280 A 9	3303 C 7	3384 C 5	3436 A 6	3485 A 3	5100 C 8	6150 C
1104 C 7	1304 A 1	1412 C 9	2018 B 7	2038 A 7	2111 C 9	2216 C 9	2244 B 9	2302 C 7	2370 C 7	2410 B 1	2433 A 4	2472 A 6	2487 B 1	2526 A 2	3020 B 8	3154 C 7	3240 B 9	3281 A 9	3304 C 7	3400 A 7	3460 A 5	3500 A 3	5210 C 9	6151 C
1105 C 7	1307 B 1	1480 A 3	2022 B 8	2052 A 9	2115 C 9	2218 B 9	2245 B 9	2303 C 8	2380 C 4	2423 B 2	2462 B 6	2473 A 6	2488 B 2	2527 A 2	3021 B 8	3155 C 7	3241 B 9	3282 A 9	3341 C 7	3401 A 6	3461 A 4	3503 A 4	5211 B 9	6152 C
1109 C 5	1310 B 6	1481 A 3	2025 B 8	2055 A 9	2150 C 7	2220 C 9	2250 B 9	2312 B 6	2381 C 6	2425 B 2	2463 B 5	2480 B 3	2489 B 2	3000 A 7	3023 B 7	3156 C 7	3264 A 9	3283 A 9	3342 C 7	3402 A 6	3471 B 5	3516 B 3	5212 B 9	6153 C
1200 A 9	1320 C 2	2004 A 7	2026 B 8	2058 A 9	2154 C 7	2231 C 9	2251 B 9	2315 C 6	2383 B 5	2426 B 1	2464 B 6	2481 B 2	2490 B 2	3005 A 7	3024 B 7	3157 C 7	3265 A 9	3284 A 9	3350 A 7	3403 A 7	3472 A 6	3519 A 2	5320 C 7	6154 C
1202 B 9	1401 C 4	2005 A 7	2028 B 7	2061 A 9	2156 C 7	2233 C 9	2252 B 9	2320 C 7	2392 A 7	2427 A 1	2465 B 6	2482 B 3	2491 B 2	3008 A 8	3108 C 9	3158 C 7	3266 A 9	3285 A 9	3379 C 2	3404 C 1	3473 A 5	3522 A 3	5340 A 8	6155 C
1203 A 4	1402 A 9	2012 A 8	2031 B 7	2101 C 8	2200 C 9	2235 C 9	2253 B 8	2343 A 8	2395 C 3	2428 A 1	2466 A 5	2483 B 3	2522 C 3	3013 A 8	3117 C 8	3159 C 7	3267 A 9	3294 A 9	3380 C 4	3421 A 1	3481 A 2	4003 B 9	5410 A 2	7000 A

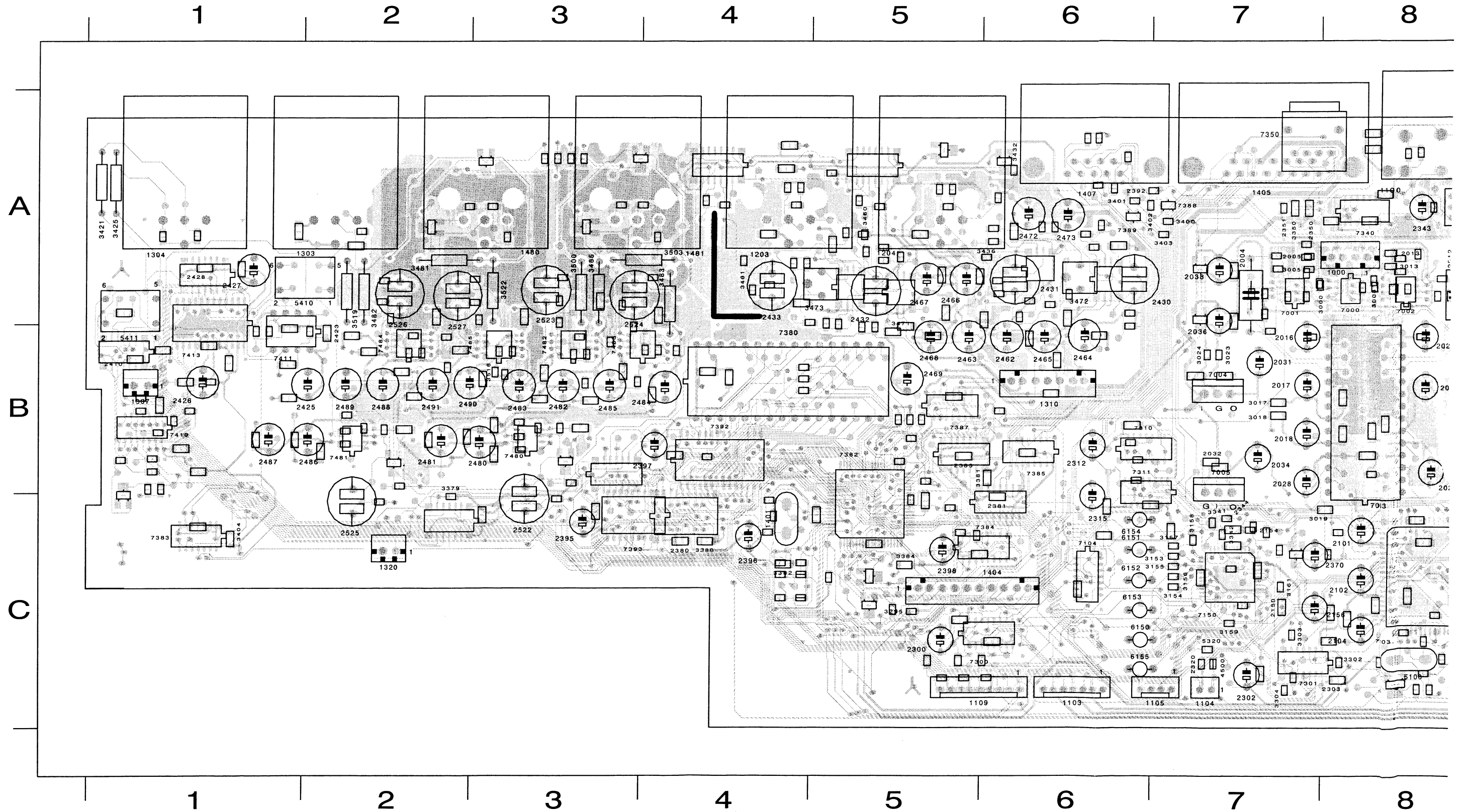

2396 C 4	2430 A 6	2467 A 5	2484 B 4	2523 A 3	3017 B 7	3119 C 9	3161 C 7	3268 A 9	3295 C 5	3381 B 6	3425 A 1	3482 A 2	4101 C 9	5411 A 1	7001 A 7	7105 C 9	7282 A 9	7383 C 1	7411 B 1
2397 B 4	2431 A 6	2468 B 5	2485 B 3	2524 A 3	3018 B 7	3120 C 8	3228 B 9	3269 A 9	3302 C 8	3382 C 4	3432 A 6	3483 A 4	4500 C 7	6100 C 8	7002 A 8	7150 C 7	7300 C 6	7384 C 6	7413 A 1
2398 C 5	2432 A 5	2469 B 5	2486 B 2	2525 C 2	3019 C 8	3153 C 7	3230 B 9	3280 A 9	3303 C 7	3384 C 5	3436 A 6	3485 A 3	5100 C 8	6150 C 6	7003 B 8	7210 C 9	7301 C 7	7385 B 6	7480 B 3
2410 B 1	2433 A 4	2472 A 6	2487 B 1	2526 A 2	3020 B 8	3154 C 7	3240 B 9	3281 A 9	3304 C 7	3400 A 7	3460 A 5	3500 A 3	5210 C 9	6151 C 6	7004 B 7	7211 B 9	7310 B 6	7387 B 5	7481 B 2
2423 B 2	2462 B 6	2473 A 6	2488 B 2	2527 A 2	3021 B 8	3155 C 7	3241 B 9	3282 A 9	3341 C 7	3401 A 6	3461 A 4	3503 A 4	5211 B 9	6152 C 6	7005 B 7	7212 B 9	7311 B 6	7388 A 7	7482 B 3
2425 B 2	2463 B 5	2480 B 3	2489 B 2	3000 A 7	3023 B 7	3156 C 7	3264 A 9	3283 A 9	3342 C 7	3402 A 6	3471 B 5	3516 B 3	5212 B 9	6153 C 6	7050 A 9	7262 A 9	7340 A 8	7389 A 6	7483 B 4
2426 B 1	2464 B 6	2481 B 2	2490 B 2	3005 A 7	3024 B 7	3157 C 7	3265 A 9	3284 A 9	3350 A 7	3403 A 7	3472 A 6	3519 A 2	5320 C 7	6154 C 6	7101 C 9	7263 A 9	7350 A 7	7392 B 4	7484 B 2
2427 A 1	2465 B 6	2482 B 3	2491 B 2	3008 A 8	3108 C 9	3158 C 7	3266 A 9	3285 A 9	3379 C 2	3404 C 1	3473 A 5	3522 A 3	5340 A 8	6155 C 6	7103 C 8	7280 A 9	7380 B 4	7393 C 3	7485 B 3
2428 A 1	2466 A 5	2483 B 3	2522 C 3	3013 A 8	3117 C 8	3159 C 7	3267 A 9	3294 A 9	3380 C 4	3421 A 1	3481 A 2	4003 B 9	5410 A 2	7000 A 8	7104 C 6	7281 A 9	7382 C 5	7410 B 1	

4

5

6

7

8

9

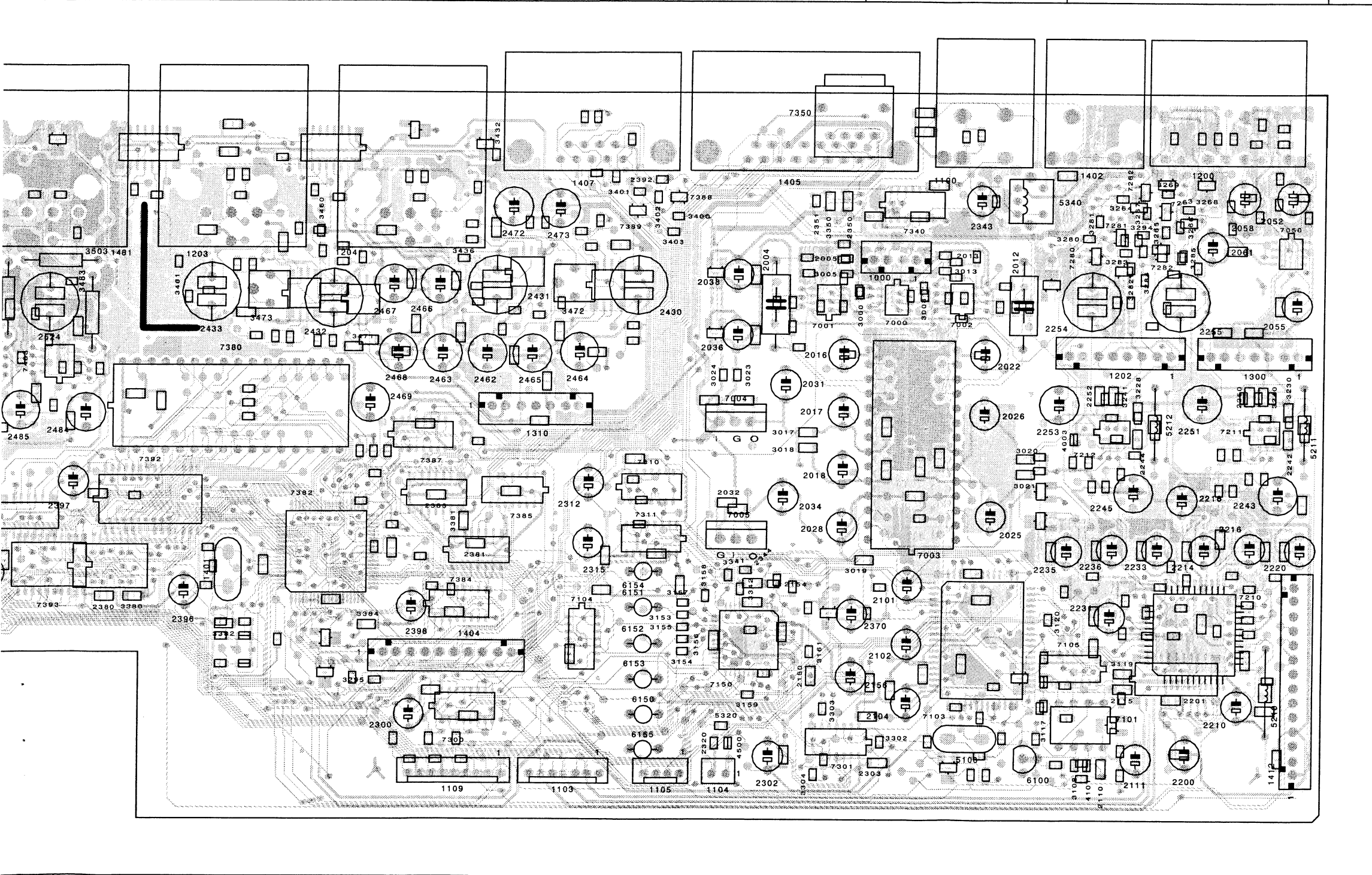

A

B

C

CDR620 ONLY

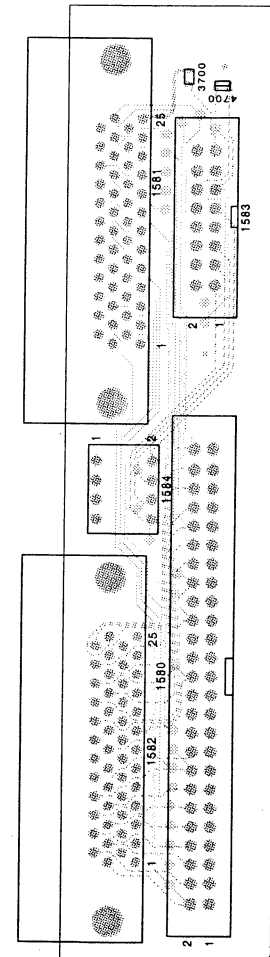

4

5

6

7

8

9

SOLDER SIDE

2007 B 7	2033 B 7	2109 C 9	2219 C 9	2239 B 9	2323 C 6	2387 C 5	2415 B 1	2440 A 6	2455 B 5	2502 A 4	2517 B 2	3014 A 8	3101 C 8	3118 C 6	3220 C 9	3237 B 9	3292 A 9	3343 A 8	3390 C 5	3415 B 1	3435 A 6	3451 A 5	3470 B 5	3498 A 3	35
2008 A 8	2035 A 7	2112 C 9	2221 C 9	2240 B 9	2324 A 9	2388 C 5	2416 B 1	2441 A 6	2456 A 5	2503 B 3	2518 A 2	3015 A 8	3102 C 8	3150 C 8	3221 C 9	3238 B 9	3293 A 9	3370 C 8	3391 C 4	3416 B 1	3437 A 6	3454 A 6	3480 A 3	3499 B 3	35
2009 A 8	2037 A 7	2113 C 9	2222 C 9	2241 B 9	2325 A 9	2389 C 4	2417 B 1	2442 A 6	2459 A 4	2504 A 3	2519 A 3	3016 B 7	3103 C 8	3151 C 7	3222 B 9	3239 B 9	3300 C 5	3371 C 7	3392 C 4	3417 B 1	3438 A 6	3455 A 5	3484 A 3	3501 A 3	35
2010 A 8	2051 A 9	2114 C 6	2223 C 9	2246 B 9	2326 A 9	2390 C 4	2418 A 1	2443 A 6	2460 A 4	2505 A 4	2520 A 4	3022 B 8	3104 C 8	3160 C 7	3223 B 9	3242 A 9	3301 C 7	3372 B 4	3393 C 4	3418 B 1	3439 A 6	3456 A 5	3486 B 3	3502 A 3	35
2011 A 8	2053 A 9	2149 C 7	2224 C 9	2247 B 9	2327 A 9	2391 B 4	2419 B 1	2444 A 6	2461 A 4	2506 B 2	2521 A 3	3050 A 9	3105 C 8	3201 C 9	3224 B 9	3243 A 9	3310 A 8	3373 B 4	3394 B 4	3419 B 1	3440 A 6	3457 A 5	3487 B 3	3504 A 4	35
2014 A 8	2054 A 9	2151 C 7	2225 C 9	2248 B 9	2340 A 9	2393 C 5	2420 B 1	2445 A 6	2492 B 3	2507 B 2	3001 A 7	3051 A 9	3106 C 8	3210 C 9	3225 B 9	3260 C 9	3311 B 6	3374 B 4	3395 B 5	3420 B 1	3441 A 6	3458 A 4	3488 B 3	3505 B 2	35
2015 A 8	2057 A 9	2152 C 7	2226 C 9	2249 B 9	2341 A 8	2394 C 3	2421 B 1	2446 A 4	2493 B 3	2508 B 2	3002 A 7	3052 A 9	3107 C 9	3211 C 9	3226 B 9	3261 B 8	3312 B 6	3375 C 5	3396 B 5	3422 B 2	3442 A 6	3459 A 4	3489 B 3	3506 B 2	35
2019 B 8	2059 A 9	2153 C 7	2227 C 9	2230 C 6	2342 A 8	2399 C 1	2422 A 2	2447 B 5	2494 B 3	2509 B 2	3003 A 7	3053 A 9	3109 C 8	3212 C 9	3227 B 9	3262 C 9	3313 C 6	3376 C 5	3397 B 5	3423 B 1	3443 B 5	3462 A 4	3490 C 3	3507 B 2	35
2020 B 8	2060 A 9	2157 C 7	2228 C 9	2304 C 7	2345 A 8	2400 C 3	2424 B 1	2448 A 5	2495 B 3	2510 B 2	3004 A 7	3054 A 9	3110 C 8	3213 C 9	3229 B 9	3263 B 8	3314 C 7	3378 B 4	3398 B 5	3424 A 2	3444 A 5	3463 A 4	3491 B 3	3508 B 2	35
2021 B 8	2100 C 8	2158 C 7	2229 C 9	2310 A 8	2371 C 8	2408 A 1	2434 A 5	2449 A 4	2496 B 3	2511 B 3	3006 A 7	3055 A 9	3111 C 8	3214 B 9	3231 B 9	3286 A 9	3330 A 6	3383 B 4	3399 C 5	3426 B 1	3445 A 4	3464 B 6	3492 B 3	3509 C 2	35

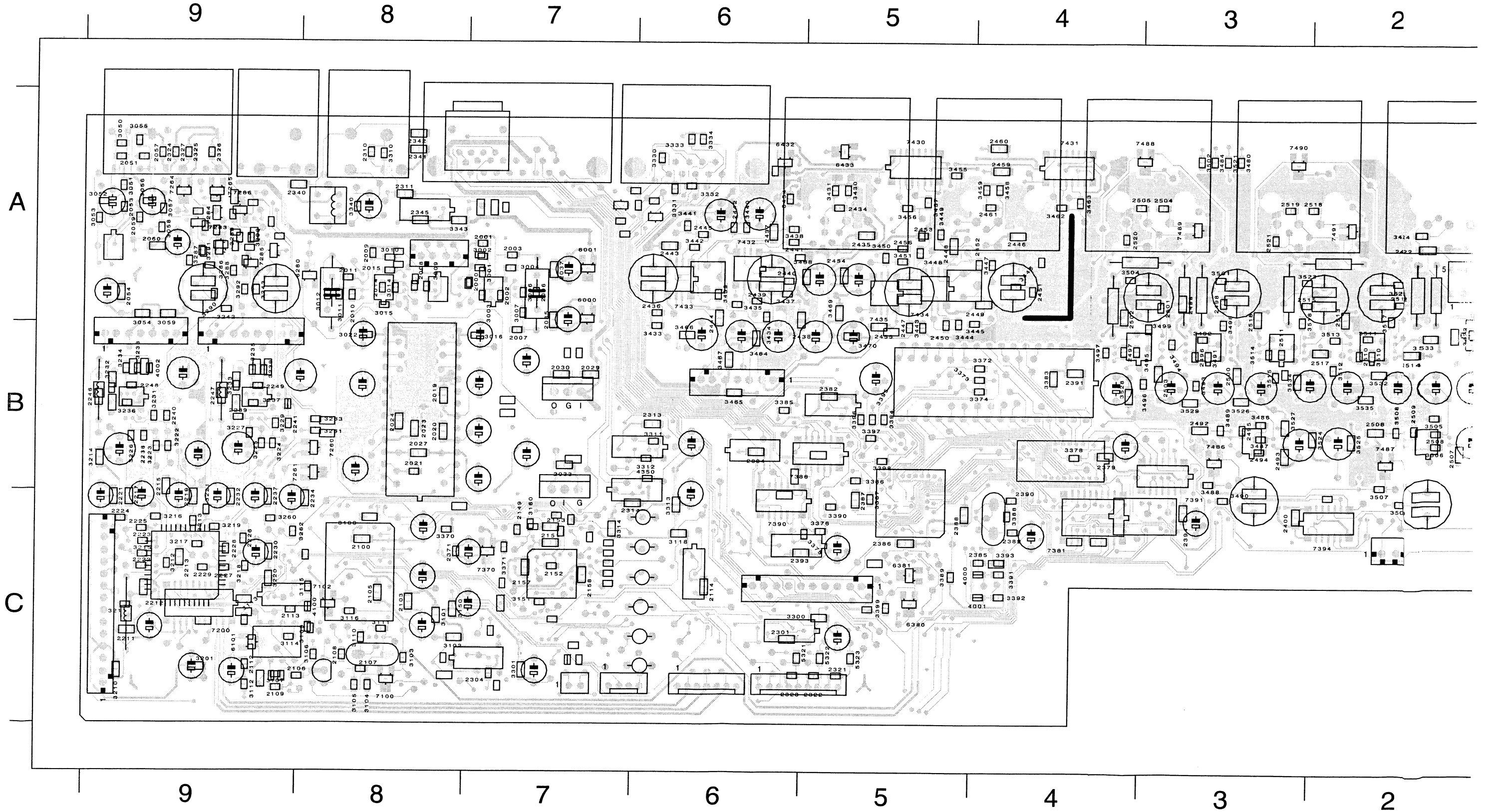

4	2517 B 2	3014 A 8	3101 C 8	3118 C 6	3220 C 9	3237 B 9	3292 A 9	3343 A 8	3390 C 5	3415 B 1	3435 A 6	3451 A 5	3470 B 5	3498 A 3	3515 B 3	3533 B 2	6380 C 5	7286 A 9	7486 B 3
3	2518 A 2	3015 A 8	3102 C 8	3150 C 8	3221 C 9	3238 B 9	3293 A 9	3370 C 8	3391 C 4	3416 B 1	3437 A 6	3454 A 6	3480 A 3	3499 B 3	3517 A 2	3534 B 3	6381 C 5	7370 C 7	7487 B 2
3	2519 A 3	3016 B 7	3103 C 8	3151 C 7	3222 B 9	3239 B 9	3300 C 5	3371 C 7	3392 C 4	3417 B 1	3438 A 6	3455 A 5	3484 A 3	3501 A 3	3518 A 3	3535 B 2	6400 C 1	7381 C 4	7488 A 3
4	2520 A 4	3022 B 8	3104 C 8	3160 C 7	3223 B 9	3242 A 9	3301 C 7	3372 B 4	3393 C 4	3418 B 1	3439 A 6	3456 A 5	3486 B 3	3502 A 3	3520 A 2	4000 C 4	6432 A 6	7386 B 5	7489 A 3
2	2521 A 3	3050 A 9	3105 C 8	3201 C 9	3224 B 9	3243 A 9	3310 A 8	3373 B 4	3394 B 5	3419 B 1	3440 A 6	3457 A 5	3487 B 3	3504 A 4	3521 A 3	4001 C 4	6433 A 5	7390 C 6	7490 A 3
2	3001 A 7	3051 A 9	3106 C 8	3210 C 9	3225 B 9	3260 C 9	3311 B 6	3374 B 4	3395 B 5	3420 B 1	3441 A 6	3458 A 4	3488 B 3	3505 B 2	3523 A 3	4002 B 9	7100 C 8	7391 B 3	7491 A 2
2	3002 A 7	3052 A 9	3107 C 9	3211 C 9	3226 B 9	3261 B 8	3312 B 6	3375 C 5	3396 B 5	3422 B 2	3442 A 6	3459 A 4	3489 B 3	3506 B 2	3524 B 2	4100 C 8	7102 C 8	7394 C 2	
2	3003 A 7	3053 A 9	3109 C 8	3212 C 9	3227 B 9	3262 C 9	3313 C 6	3376 C 5	3397 B 5	3423 B 1	3443 B 5	3462 A 4	3490 C 3	3507 B 2	3525 B 2	4350 B 6	7200 C 9	7412 B 1	
2	3004 A 7	3054 A 9	3110 C 8	3213 C 9	3229 B 9	3263 B 8	3314 C 7	3378 B 4	3398 B 5	3424 A 2	3444 A 5	3463 A 4	3491 B 3	3508 B 2	3526 B 3	5321 C 6	7260 B 8	7414 A 1	
3	3006 A 7	3055 A 9	3111 C 8	3214 B 9	3231 B 9	3266 A 9	3330 A 6	3383 B 4	3399 C 5	3426 B 1	3445 A 4	3464 B 6	3492 B 3	3509 C 2	3527 B 3	5322 C 5	7261 B 8	7430 A 5	

6 5 4 3 2 1

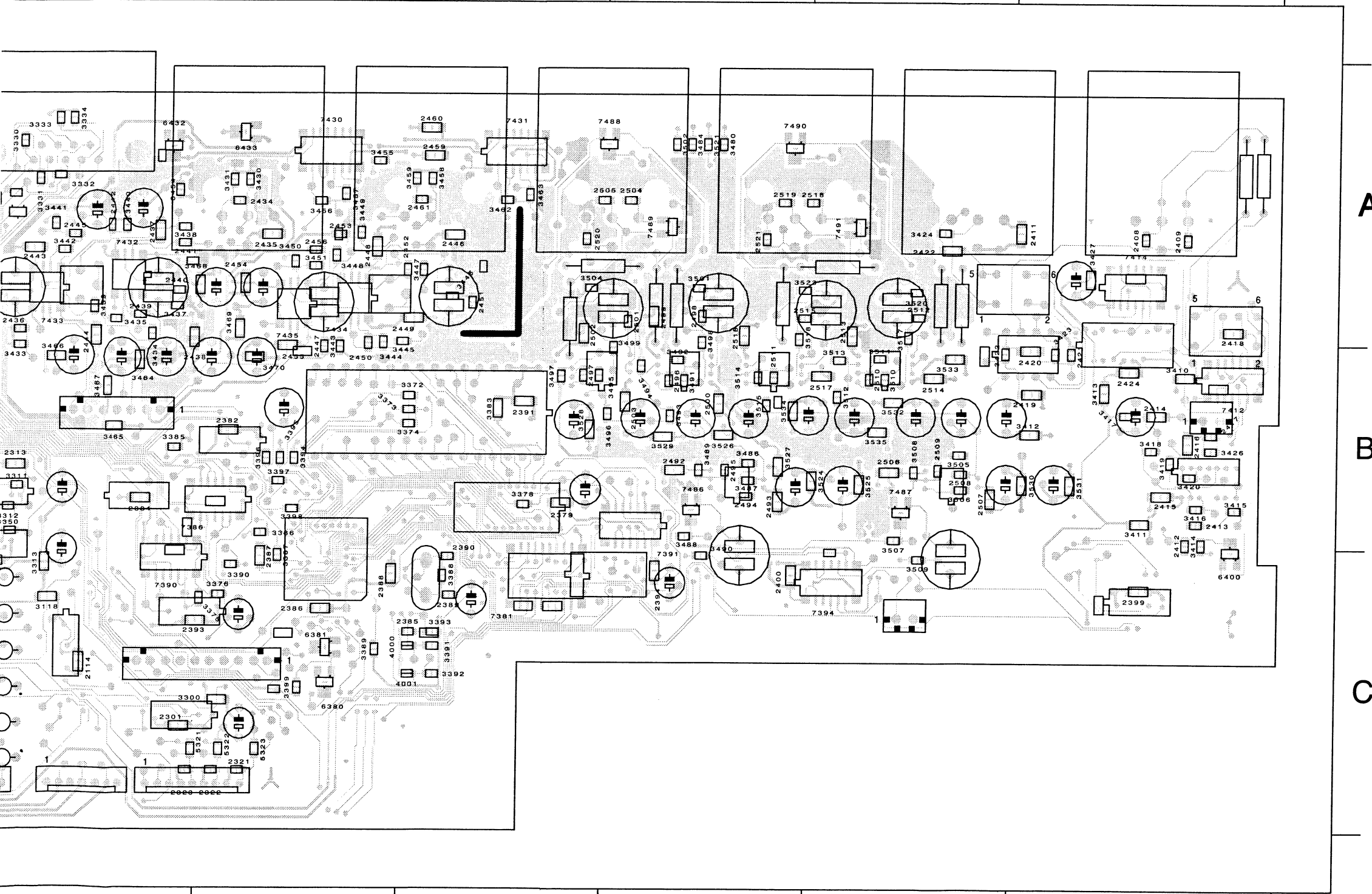

A

B

C

CDR620 ONLY

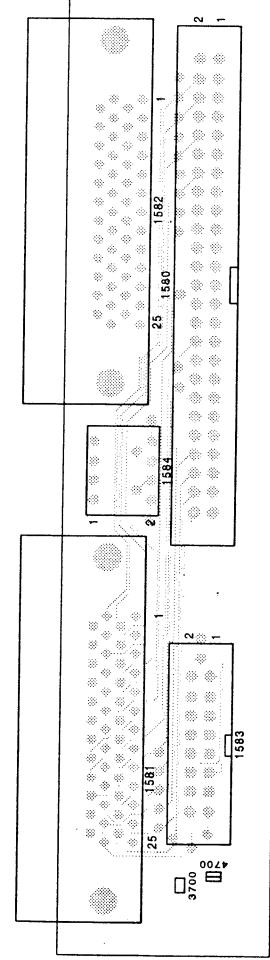

6 5 4 3 2 1

DISPLAY

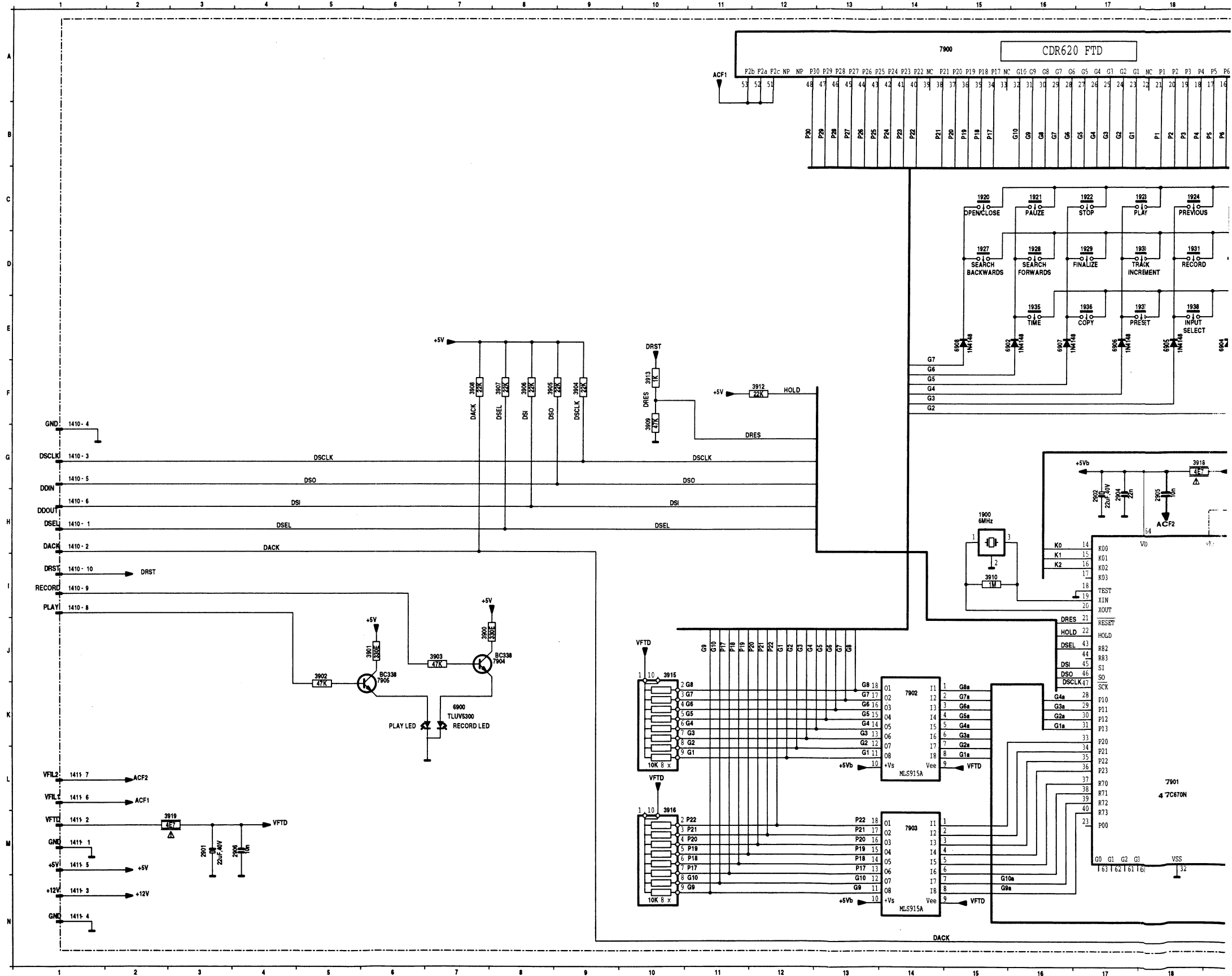

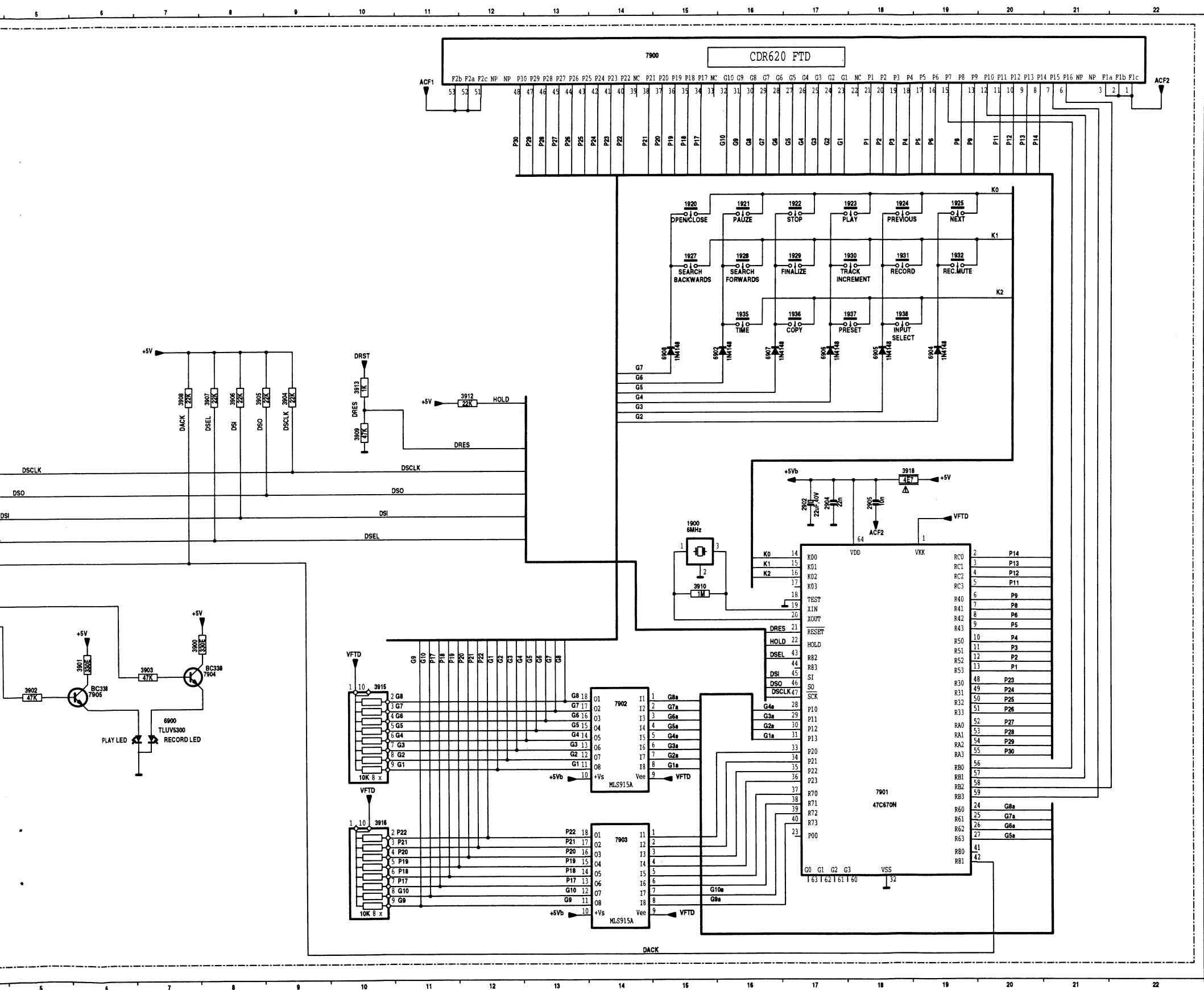

- 1410 H 1
- 1410 H 1
- 1410 F 1
- 1410 G 1
- 1410 H 1
- 1410 F 1
- 1410 I 1
- 1410 J 1
- 1411 M 1
- 1411 N 1
- 1411 N 1
- 1411 M 1
- 1411 L 1
- 1411 L 1
- 1900 H15
- 1900 F 4
- 1900 C15
- 1900 C16
- 1900 C17
- 1900 C18
- 1900 C18
- 1900 C19
- 1900 D15
- 1900 D16
- 1900 D17
- 1900 D18
- 1900 D18
- 1900 D19
- 1900 E16
- 1900 E17
- 1900 E18
- 1900 F 5
- 1900 M 3
- 1900 H17
- 1900 F 5
- 1900 H17
- 1900 H18
- 1900 M 4
- 1900 J 7
- 1900 J 8
- 1900 J 5
- 1900 J 9
- 1900 F 9
- 1900 F 9
- 1900 F 8
- 1900 F 8
- 1900 F 7
- 1900 F10
- 1910 I15
- 1910 E 4
- 1910 F12
- 1910 F10
- 1914 F 2
- 1915 J10
- 1916 M10
- 1917 E 4
- 1918 G18
- 1919 M 3
- 1900 K 7
- 6902 E16
- 6904 E19
- 6905 E18
- 6905 E18
- 6905 E17
- 6907 E16
- 6908 E15
- 7900 A14
- 7901 L18
- 7902 K14
- 7903 M14
- 7904 J 8
- 7905 K 6

DISPLAY BOARD

COMPONENT SIDE

1410 A 6	1921 B 1	1927 B 3	1932 B 4	2900 B 1	2905 B 4	3903 A 5	3908 A 6	3915 A 2	6900 B 2	6907 A 1	7903 A 1	9002 B 4	9007 B 5	9012 B 3	9017 B 2	9023 A 6	9028 A 4
1411 B 1	1922 B 2	1928 B 4	1935 A 6	2901 B 1	2906 B 1	3904 A 6	3909 A 5	3916 A 1	6902 A 1	6908 A 1	7904 B 6	9003 B 4	9008 A 4	9013 B 1	9018 B 3	9024 A 5	9029 A 4
1900 A 3	1923 B 2	1929 B 6	1936 B 6	2902 B 4	3900 B 5	3905 A 6	3910 A 3	3917 B 2	6904 B 1	7900 A 2	7905 B 6	9004 A 5	9009 B 2	9014 B 1	9019 B 3	9025 A 5	9030 A 4
1902 A 1	1924 B 3	1930 B 6	1937 A 6	2903 A 1	3901 B 5	3906 A 5	3912 A 4	3918 B 4	6905 B 1	7901 A 3	9000 B 1	9005 A 5	9010 B 2	9015 B 2	9021 A 4	9026 A 4	9031 A 4
1920 B 1	1925 B 4	1931 B 5	1938 B 6	2904 B 4	3902 A 5	3907 A 6	3913 A 5	3919 B 1	6906 B 1	7902 A 2	9001 B 5	9006 A 4	9011 B 1	9016 B 2	9022 A 4	9027 A 4	

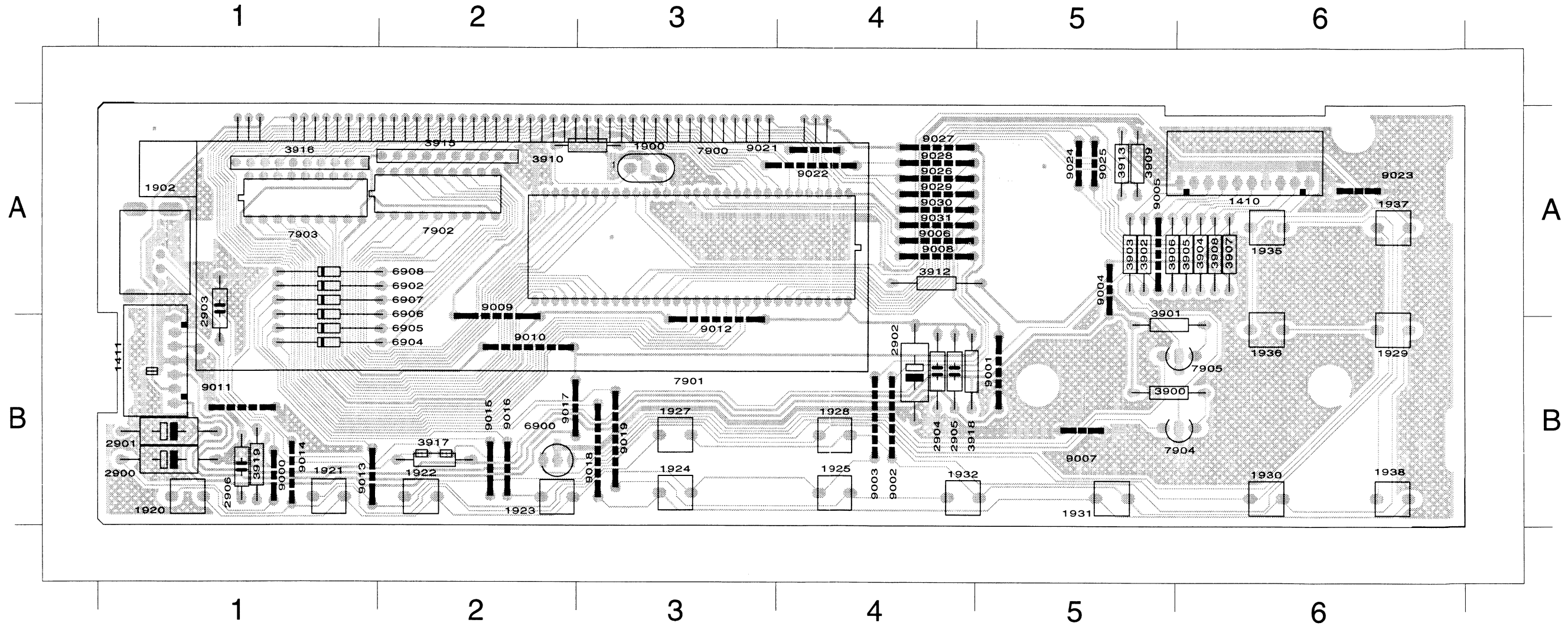

DISPLAY BOARD

SOLDER SIDE

3911 B 2 3914 B 2 4900 B 1

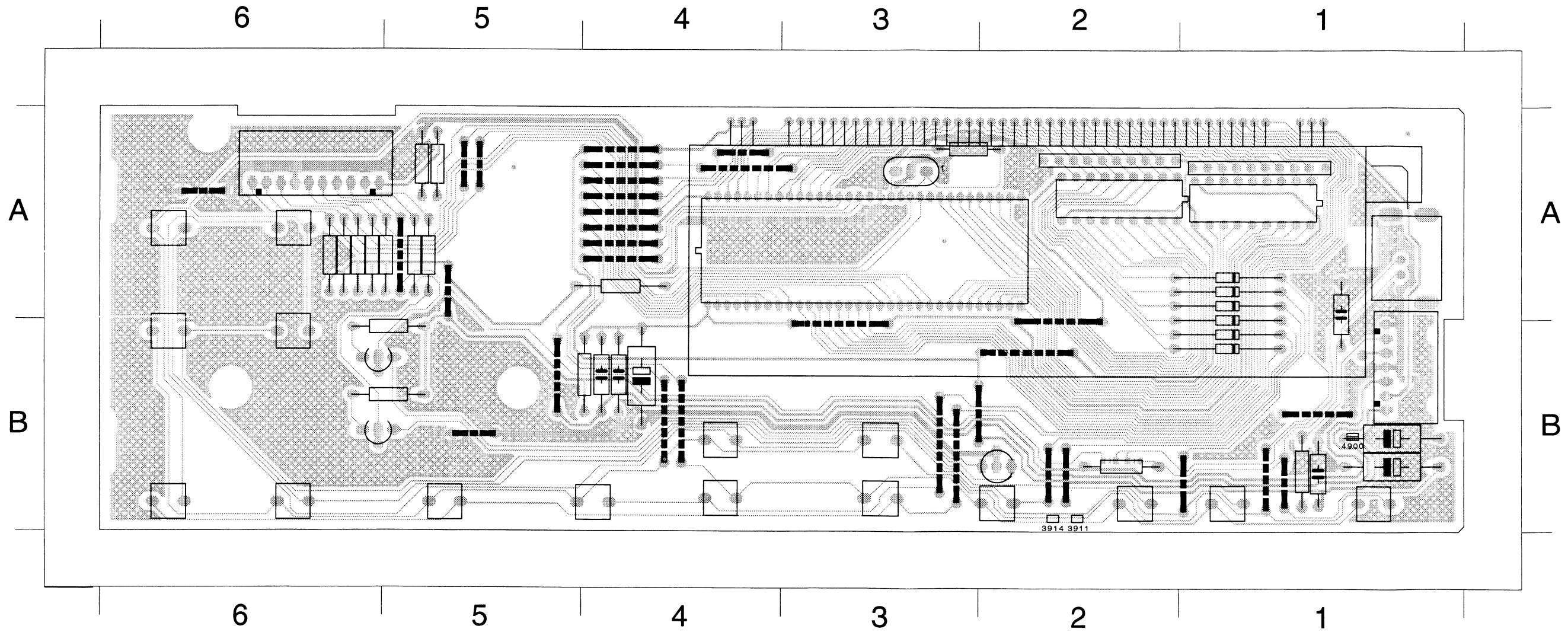

HEADPHONE

1650 A 1	1650 C 1	1650 D 1	2650 A 2	2653 D 9	2656 E 10	3652 A 2	3655 B 7	3658 D 8	3661 C 6	7650 B 3	7652 A 7
1650 A 1	1650 B 1	1650 D 1	2651 D 2	2654 E 7	3650 C 2	3653 A 8	3656 D 2	3659 C 7	3662 A 4	7651 C 3	
1650 B 1	1650 C 1	1651 D 10	2652 D 9	2655 C 7	3651 B 2	3654 B 6	3657 D 5	3660 E 7	3662 D 4	7652 D 6	

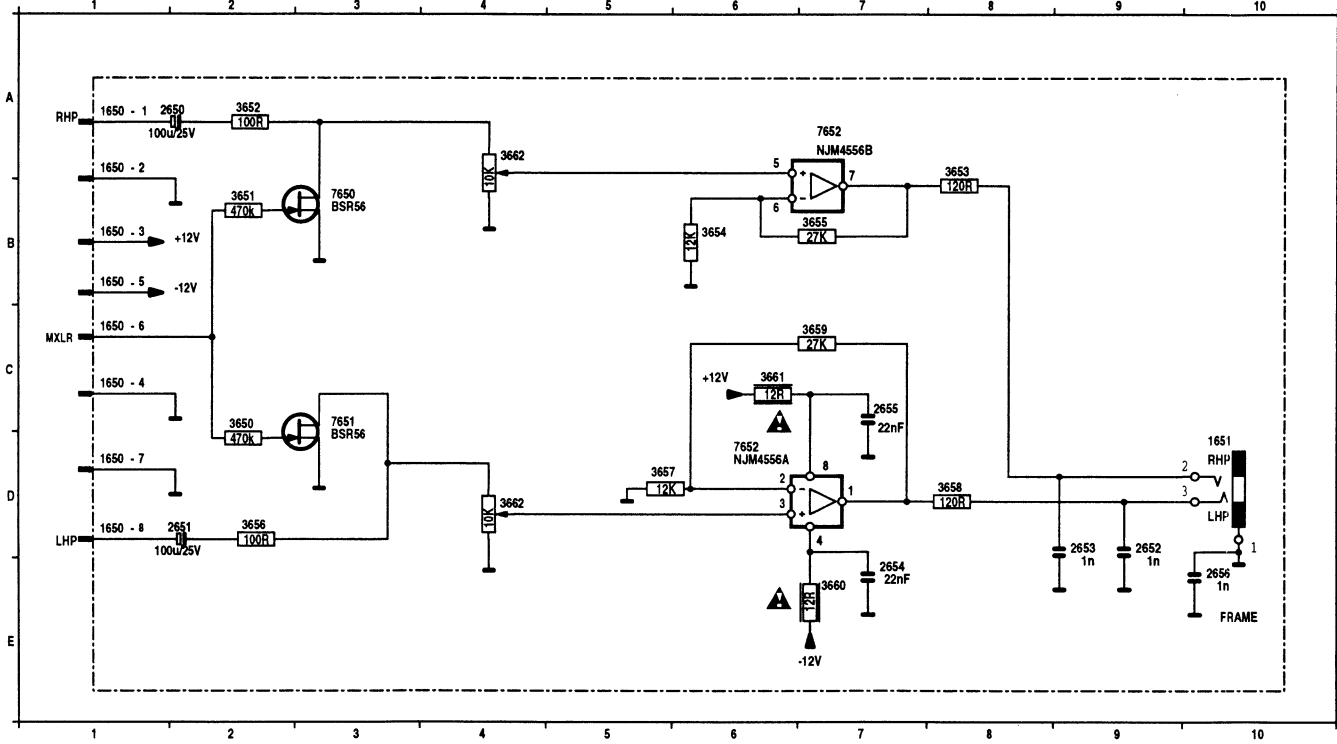

HEAD PHONE BOARD

COMPONENT SIDE

1650 A 1	2650 A 1	3651 A 2	3662 B 2	9064 A 1	9066 A 3
1651 A 3	2651 B 1	3658 A 2	7652 A 1	9065 A 3	

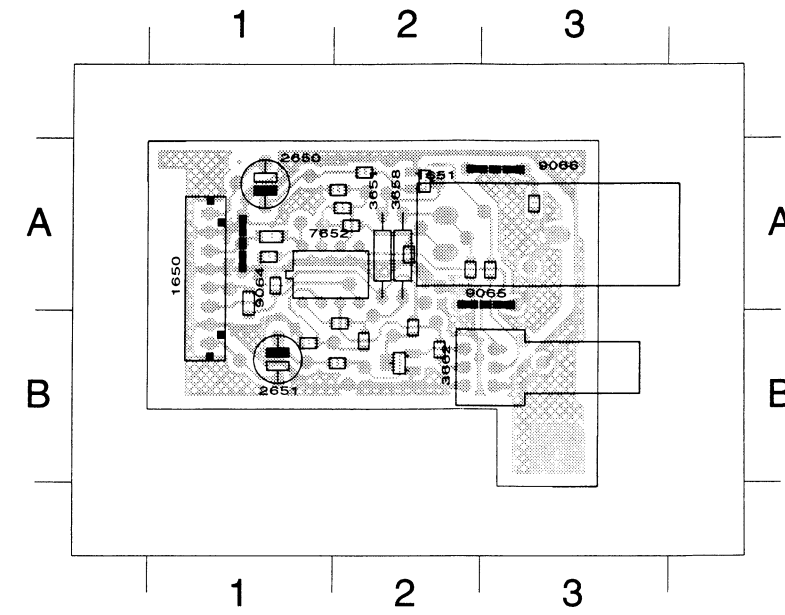

SOLDER SIDE

2652 A 2	2655 A 1	3652 A 2	3655 A 2	3659 B 2	4000 B 2	7650 A 2
2653 A 2	2656 A 3	3653 A 2	3656 B 2	3660 A 1	4001 A 3	7651 B 2
2654 A 1	3650 B 2	3654 A 2	3657 B 1	3661 A 1	4603 B 2	

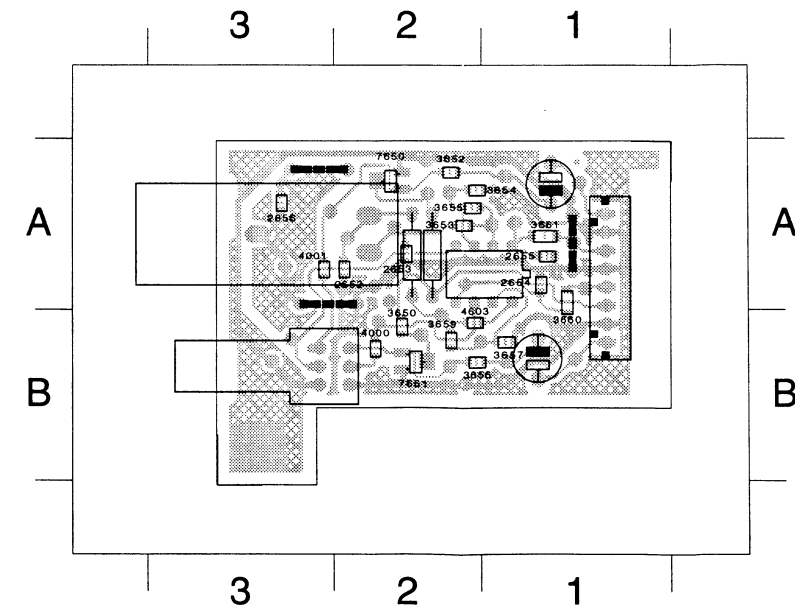

POWER SUPPLY

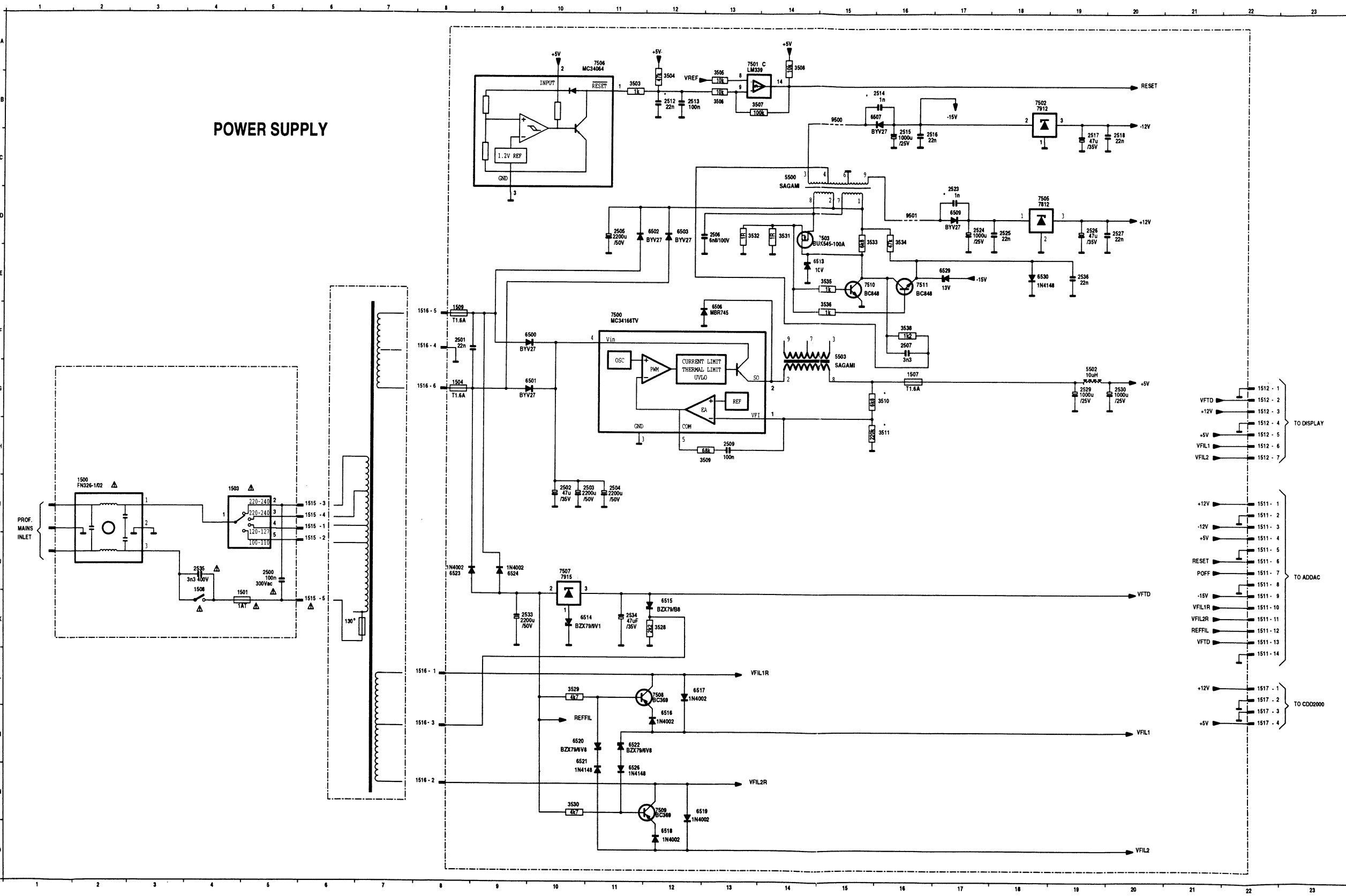

1500 L2	7508 L12
1501 K5	7509 M12
1502 E15	7510 E15
1503 I4	7511 E16
1504 G8	8002 H5
1505 B15	8036 H5
1506 D16	8500 B15
1507 G16	8501 D16
1508 K4	8502 G16
1509 F8	
1511 J22	
1512 J22	
1513 J22	
1514 J22	
1515 J22	
1516 J22	
1517 J22	
1518 J22	
1519 J22	
1520 J22	
1521 J22	
1522 J22	
1523 J22	
1524 J22	
1525 J22	
1526 J22	
1527 J22	
1528 J22	
1529 J22	
1530 J22	
1531 J22	
1532 J22	
1533 J22	
1534 J22	
1535 J22	
1536 J22	
1537 J22	
1538 J22	
1539 J22	
1540 J22	
1541 J22	
1542 J22	
1543 J22	
1544 J22	
1545 J22	
1546 J22	
1547 J22	
1548 J22	
1549 J22	
1550 J22	
1551 J22	
1552 J22	
1553 J22	
1554 J22	
1555 J22	
1556 J22	
1557 J22	
1558 J22	
1559 J22	
1560 J22	
1561 J22	
1562 J22	
1563 J22	
1564 J22	
1565 J22	
1566 J22	
1567 J22	
1568 J22	
1569 J22	
1570 J22	
1571 J22	
1572 J22	
1573 J22	
1574 J22	
1575 J22	
1576 J22	
1577 J22	
1578 J22	
1579 J22	
1580 J22	
1581 J22	
1582 J22	
1583 J22	
1584 J22	
1585 J22	
1586 J22	
1587 J22	
1588 J22	
1589 J22	
1590 J22	
1591 J22	
1592 J22	
1593 J22	
1594 J22	
1595 J22	
1596 J22	
1597 J22	
1598 J22	
1599 J22	
1600 J22	

**POWER SUPPLY BOARD
COMPONENT SIDE**

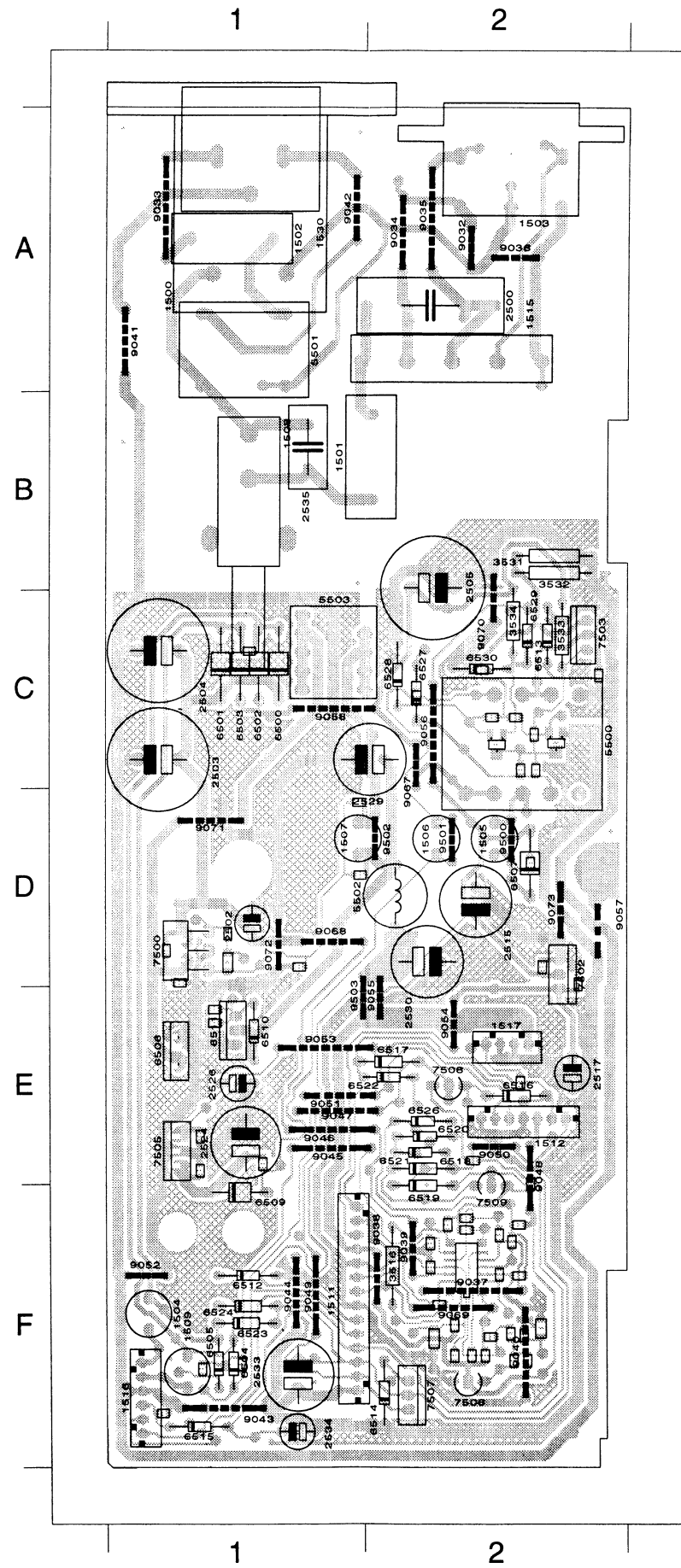

- | | |
|----------|----------|
| 1500 A 1 | 9073 D 2 |
| 1501 B 2 | 9500 D 2 |
| 1502 A 1 | 9501 D 2 |
| 1503 A 2 | 9502 D 2 |
| 1504 F 1 | 9503 E 1 |
| 1505 D 2 | |
| 1506 D 2 | |
| 1507 D 1 | |
| 1508 B 1 | |
| 1509 F 1 | |
| 1511 F 1 | |
| 1512 E 2 | |
| 1515 A 2 | |
| 1516 F 1 | |
| 1517 E 2 | |
| 1530 A 1 | |
| 2500 A 2 | |
| 2502 D 1 | |
| 2503 C 1 | |
| 2504 C 1 | |
| 2505 B 2 | |
| 2515 D 2 | |
| 2517 E 2 | |
| 2524 E 1 | |
| 2526 E 1 | |
| 2529 C 2 | |
| 2530 D 2 | |
| 2533 F 1 | |
| 2534 F 1 | |
| 2535 B 1 | |
| 3516 F 2 | |
| 3531 B 2 | |
| 3532 B 2 | |
| 3533 C 2 | |
| 3534 C 2 | |
| 5500 C 2 | |
| 5501 A 1 | |
| 5502 D 2 | |
| 5503 C 1 | |
| 6500 C 1 | |
| 6501 C 1 | |
| 6502 C 1 | |
| 6503 C 1 | |
| 6504 F 1 | |
| 6505 F 1 | |
| 6506 E 1 | |
| 6507 D 2 | |
| 6509 F 1 | |
| 6510 E 1 | |
| 6511 E 1 | |
| 6512 F 1 | |
| 6513 C 2 | |
| 6514 F 2 | |
| 6515 F 1 | |
| 6516 E 2 | |
| 6517 E 2 | |
| 6518 E 2 | |
| 6519 F 2 | |
| 6520 E 2 | |
| 6521 E 2 | |
| 6522 E 2 | |
| 6523 F 1 | |
| 6524 F 1 | |
| 6526 E 2 | |
| 6527 C 2 | |
| 6528 C 2 | |
| 6529 C 2 | |
| 6530 C 2 | |
| 7500 D 1 | |
| 7502 D 2 | |
| 7503 C 2 | |
| 7505 E 1 | |
| 7506 F 2 | |
| 7507 F 2 | |
| 7508 E 2 | |
| 7509 F 2 | |
| 9032 A 2 | |
| 9033 A 1 | |
| 9034 A 2 | |
| 9035 A 2 | |
| 9036 A 2 | |
| 9037 F 2 | |
| 9038 F 2 | |
| 9039 F 2 | |
| 9040 F 2 | |
| 9041 A 1 | |
| 9042 A 1 | |
| 9043 F 1 | |
| 9044 F 1 | |
| 9045 E 1 | |
| 9046 E 1 | |
| 9047 E 1 | |
| 9048 E 2 | |
| 9049 F 1 | |
| 9050 E 2 | |
| 9051 E 1 | |
| 9052 F 1 | |
| 9053 E 1 | |
| 9054 E 2 | |
| 9055 E 2 | |
| 9056 C 2 | |
| 9057 D 2 | |
| 9058 C 1 | |
| 9067 C 2 | |
| 9068 D 1 | |
| 9069 F 2 | |
| 9070 C 2 | |
| 9071 D 1 | |
| 9072 D 1 | |

SOLDER SIDE

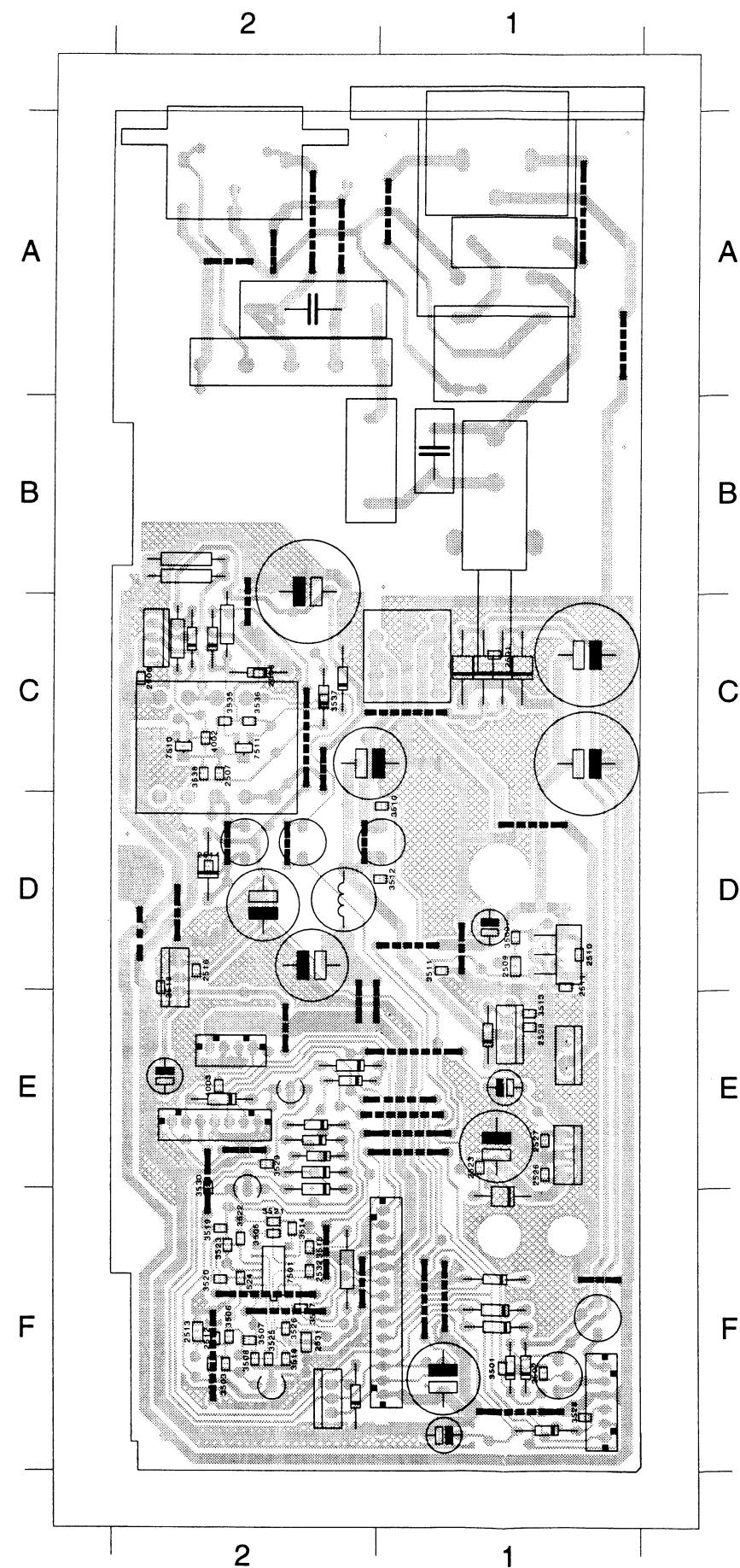

- | |
|----------|
| 2501 C 1 |
| 2506 C 2 |
| 2507 C 2 |
| 2509 D 1 |
| 2510 D 1 |
| 2511 D 1 |
| 2512 F 2 |
| 2513 F 2 |
| 2514 D 2 |
| 2516 D 2 |
| 2518 D 2 |
| 2523 E 1 |
| 2525 E 1 |
| 2527 E 1 |
| 2528 E 1 |
| 2531 F 2 |
| 2532 F 2 |
| 2536 C 2 |
| 3501 F 1 |
| 3502 F 1 |
| 3503 F 2 |
| 3504 F 2 |
| 3505 F 2 |
| 3506 F 2 |
| 3507 F 2 |
| 3508 F 2 |
| 3509 D 1 |
| 3510 D 1 |
| 3511 D 1 |
| 3512 D 1 |
| 3513 E 1 |
| 3514 F 2 |
| 3515 F 2 |
| 3517 F 2 |
| 3518 F 2 |
| 3519 F 2 |
| 3520 F 2 |
| 3521 F 2 |
| 3522 F 2 |
| 3523 F 2 |
| 3524 F 2 |
| 3525 F 2 |
| 3526 F 2 |
| 3528 F 1 |
| 3529 E 2 |
| 3530 E 2 |
| 3535 C 2 |
| 3536 C 2 |
| 3537 C 2 |
| 3538 C 2 |
| 4002 C 2 |
| 4003 E 2 |
| 7501 F 2 |
| 7510 C 2 |
| 7511 C 2 |

1.7 EXPLODED VIEW AND PARTS LIST

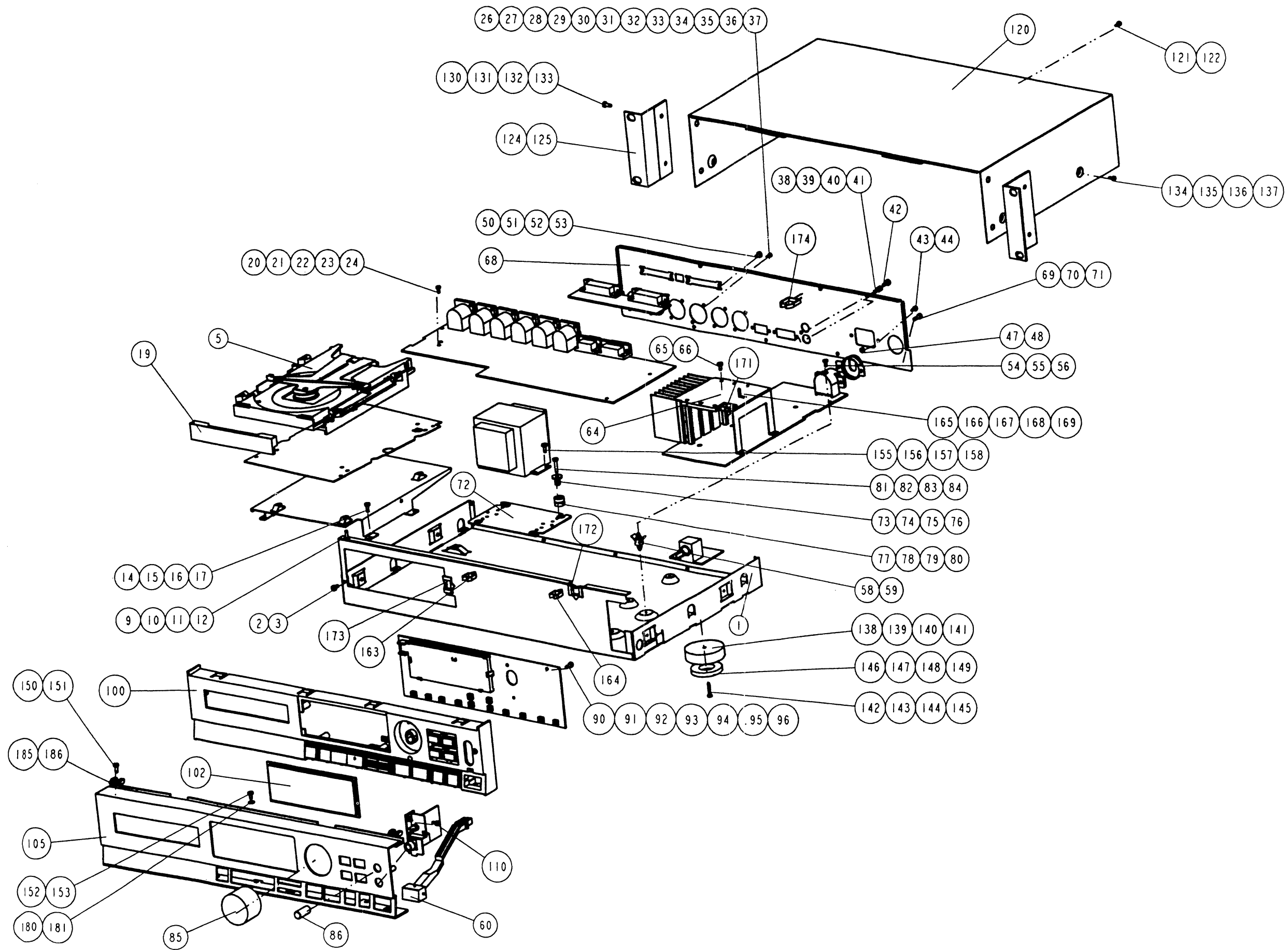

(VERS.:VERSION, U:U.S.A., F:JAPAN, K:FAR EAST, **:EUROPE)

POS. NO	VERS. COLOR	PART NO.	DESCRIPTION
19	/02B /06B	4822 459 04002	TRAY FRONT
19	/02M	4822 459 04098	TRAY FRONT
50		4822 502 13952	M 2 X 6T/PAN<STNI
51		4822 502 13952	M 2 X 6T/PAN<STNI
52		4822 502 13952	M 2 X 6T/PAN<STNI
53		4822 502 13952	M 2 X 6T/PAN<STNI
60	/02B /06B	4822 535 10245	POWER ROD
60	/02M	4822 535 10246	POWER ROD
63		4822 256 10138	FTD HOLDER
64		4822 502 30303	2.9X 6.5PANF<STZNBK
65		4822 502 30303	2.9X 6.5PANF<STZNBK
66		4822 502 30303	2.9X 6.5PANF<STZNBK
65		4822 502 30303	2.9X 6.5PANF<STZNBK
▲ 66		4822 492 63076	SPRING
▲ 67		4822 492 63076	SPRING
▲ 68		4822 492 63076	SPRING
85	/02B /06B	4822 410 10117	LEVEL KNOB
85	/02M	4822 410 10291	LEVEL KNOB
86	/02B /06B	4822 410 10118	VOLUME KNOB
86	/02M	4822 410 10292	VOLUME KNOB
100	/02B /06B	4822 459 03999	PLASTIC FRONT ASSY
100	/02M	4822 459 04099	PLASTIC FRONT ASSY
102		4822 450 10054	WINDOW
105	/02B /06B	4822 459 04001	ALU FRONT ASSY (CDR620)
105	/02B /06B	4822 459 04138	ALU FRONT ASSY (CDR615)
105	/02M	4822 459 04101	ALU FRONT ASSY (CDR620)
105	/02M	4822 459 04139	ALU FRONT ASSY (CDR615)
120	/02B /06B	4822 442 00004	COVER ASSY
120	/02M	4822 442 00145	COVER ASSY
124	/02B /06B	4822 402 10041	BRACKET
124	/02M	4822 402 10152	BRACKET
125	/02B /06B	4822 402 10041	BRACKET
125	/02M	4822 402 10152	BRACKET
138	/02B /06B	4822 462 41715	FOOT
138	/02M	4822 462 41992	FOOT
139	/02B /06B	4822 462 41715	FOOT
139	/02M	4822 462 41992	FOOT
140	/02B /06B	4822 462 41715	FOOT
140	/02M	4822 462 41992	FOOT
141	/02B /06B	4822 462 41715	FOOT
141	/02M	4822 462 41992	FOOT
▲ 146	/02B /06B	4822 466 93071	FELT
146	/02M	4822 462 40409	FELT
▲ 147	/02B /06B	4822 466 93071	FELT
147	/02M	4822 462 40409	FELT
▲ 148	/02B /06B	4822 466 93071	FELT
148	/02M	4822 462 40409	FELT
▲ 149	/02B /06B	4822 466 93071	FELT
149	/02M	4822 462 40409	FELT
160		4822 381 11654	LENS
180		4822 530 80263	EXT 3.2SERRSTZNBK
▲ 301	/02B /02M	4822 321 10741	MAINS CORD /02M
▲ 301	/06B	4822 321 10746	MAINS CORD /06B
▲ 301	F	Z C 0 1 5 0 1 0 2 0	MAINS CORD (JPN)
309	/02B /02M	4822 736 14081	USER MANUAL(EU) (CDR620)
309	/02B /02M	4822 736 14258	USER MANUAL(EU) (CDR615)
309	/06B	4822 736 14082	USER MANUAL(USA) (CDR620)
309	/06B	4822 736 14262	USER MANUAL(USA) (CDR615)
309	F	3 1 6 K 8 5 1 1 1 0	USER MANUAL(JPN)

1.8 CIRCUIT DESCRIPTION

1.8.1 SERVICE PRESCRIPTION

1. GENERAL DESCRIPTION

1.1 INTRODUCTION

This document describes the service of the CDR620 /CDR615.

Service of the CDR620/CDR615 can be divided into two parts:

- Servicing the CDR-Module (for Marantz)
- Servicing the CDR620 /CDR615-User (Monoboard)

2. SERVICE OF THE CDR620 / CDR615 -MODULE

All repairs to this are to be done by a Central Repair Station only.

Servicing the CDR-Module can be handled into two ways:

- Via SCSI
 - This means that you must connect a PC To the SCSI connector.
- Via RS232
 - This is possible with a Connection PCB (RS232 converter)
 - Also her you must connect a PC to this PCB.

2.1 SERVICE THE CDR-MODULE VIA SCSI

In this service mode the user can set the player in SCSI-mode by means of the preset feature.

All servicing requests can be given via the SCSI-interface.

For a detailed description of all commands refer to the document:

- SCSI command set CDD2000 V2.01 November 1995

-The CDR-Module always starts-up with SCSI-interface enabled.

When the CDR620/CDR615-User is connected to the CDR-Module the SCSI-OFF command

will be transferred to the CDR-Module. So, for keeping the CDR-Module into SCSI-

mode two possible solutions can be handled:

- Disconnect CDR620/CDR615-User
 - The following strategy should be followed:
 - Power off the CDR620/CDR615 set.
 - Disconnect CDR620/CDR615-User from CDR-Module.
 - 1 cables
 - pos. 1109 of the CDR620/CDR615-User.
 - Power on the CDR620/CDR615.
 - Wait now for 3 seconds.
- Now the user can issue all service commands via SCSI.
- How to use the service commands ?
 - Their is no difference between the CDR620/CDR615 and CDD2000 module.
 - Only the audio part is deleted from the PCB. This has no impact for servicing the CDR620/CDR615-Module.
 - All SCSI command will be the same except the play audio command.
 - Audio via SCSI is 4x Fs Sony format. (12S)
 - Audio in our set is this FS Philips format. (12S)

2.2 HOW TO USE THE WRIBASS.EXE TOOL.

- This is a program that convert the SCSI command set into a user interface.
 - We will use this program in the service course.
- You can use this program for setting manual command.
 - Stop command
 - Start command
 - Diagnostic.....and more.
- You can run also a automatically routine made on this basic program.
 - How to run this program ?
 - Start the main program with b.bat
 - select test (6)
 - Press the key F1 or the key that is displayed in the window.
 - The following routine will be done:
 - write a track of 500 blocks at speed = 1
 - open/close (update PMA program memory area)
 - write a track of 500 blocks at speed = 2
 - open/close (update PMA)
 - reserve a track at 500 blocks
 - open/close (update PMA)
 - Read first and second track at speed = 1 (APV auto pattern verify)
 - open/close
 - Read first and second track at speed = 2 (APV)
 - open/close
 - full-up the reserve track.
 - open/close (update PMA)
 - Read first, second and third track at speed = 4 (APV)
- All this command will be logged in a log-file.
 - You can find the log-file in the directory you start-up your main program.
- A explanation of the error handling you can find on the next page.
 - This is for internal use only.

[REMARK]

CDR615 is available to use in the SCSI mode and CDR620's service procedure by replacement of the EP-ROM (7380) on the MONO Board PCB. The part number of that CDR620 EP-ROM is **4822 900 10974**. CDR615 should become same as CDR620 by this modification except some function which depend on hardware structure.

2.2.1 ERROR HANDLING

What means what in production tests ?

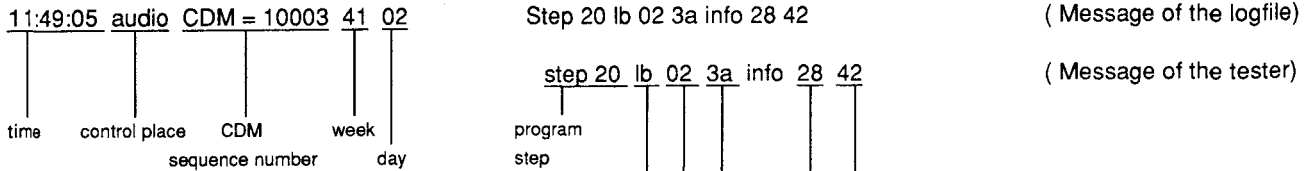

Command	Sense message	Additional sense message	Infobyte 1 (basic)	Infobyte 2 (servo)	
00 Test unit ready	00 No sense	00 No sense	00 No error	00 ready	40 NO error
01 Rezero unit	01 Recovered error	03 Tray out	01 interface command timeout	01 busy	41 startup error
03 Request sense	02 Not ready	04 Drive not ready	02 interface group busy	02 illegal request	42 startup no disc
08 Read	03 Medium error	08 Communication failure	03 interface invalid precondition	03 dma error	43 startup disk present error
0a Write	04 Hardware error	09 Track following error	04 interface invalid request id	04 not ready tray out	44 read to leadin error
0b Seek	05 Illegal request	11 Unrecovered read error	05 interface no error info	05 not ready tray in	45 jump to leadin error
12 Inquiry	06 Unit attention	15 Positioning error	10 communication	06 command sequence error	46 read toc timeout
15 Mode select	07 ???	17 Recovered read data with retries	15 communication range check	07 dsp load error	47 read atip timeout
16 Reserve	08 Blank check	18 Recovered read with ECC correction	16 command not accepted	08 illegal medium	48 read pma error
17 Release	09 Vendor specific	1a Parameter list length error	17 communication timeout	09 tray locked	49 jump to pma error
18 copy	0a ???	1b Drive error	18 communication checksum	0a tray opening error	4a incorrect track in pma
1a Mode sense	0b Aborted command	1c Controller error	1a communication max driver error	0b ready tray in	4b incorrect end of pma
1b Start/Stop	0c Mismatch	1d Selftest failed	1b communication max BR	0c selftest error	4c read pma timeout
1c Receive diagnostic	0d Volume overflow	20 Invalid command	20 servo	0d illegal address	4d jump to last volume error
1d Send diagnostic	13 APV data error	21 Invalid block address	22 off track	0e illegal track number	4e jump to last volume timeout
1e Allow/prevent		22 Illegal field in CDB	23 servo disc speed	0f illegal offset	4f read last volume error
25 Read CDROM cap		25 Invalid LUN	24 write eeprom overrun	10 illegal length	50 jump to last recorded add error
28 read long		26 Invalid field parameter list	25 servo sledge	11 tray closing error	51 jump to first track error
2a Write long		28 Medium changed	26 servo radial skating	12 no pma update needed	60 read jump error
2b Seek long		29 Power/Bus reset occurred	27 servo radial lost	13 wrong disc id	61 wrong size before read
2f Verify		2a Unit attention	28 servo focus	14 opc area almost full	62 wrong size during read
35 Flush cache		2c Command sequence error	30 player	15 pma is full	63 erroneous data received
3b Write buffer		30 Cannot read medium format unknown	33 player record power low warning	16 disc is write protected	64 incorrect header address
3c Read buffer		31 Medium format corrupted	34 player record sync warning	17 wrong application code	65 read error
42 Read Sub channel		33 Monitor ATIP error	33 player record power limit warning	18 illegal block size for write	66 motor not ready error
43 Read disk info		34 Absorption control error	36 player window	19 disc is full	67 link blocks encountered
45 Play audio		3a Medium not present	37 player link	1a not writable track	68 read subcode timeout
47 Play audio MSF		3d bits in identify message	38 player access	1b audio in res track not allowed	69 incorrect link area
48 Play audio t/f		40 Diagnostic failure	40 opc	1c raw data in res track not allowed	6a link area expected
4b Pause/Resume		42 Power on selftest failure	41 opc alpha power range	1d wrong mix mode	6b incorrect logical address
55 Mode select long		44 Internal controller error	42 opc alpha lower range	1e subheaders expected	6c read address not found
5a Mode sense long		47 SCSI parity error	43 opc alpha upper range	1f wrong submode form	6d read no efm found
d2 Read OPC info		50 Write append error	44 opc beta lower range	20 illegal session number	6e read no header sync found
d3 Write OPC info		53 Medium load or eject failed	45 opc beta upper range	21 end of user area encountered	6f read start address not found
e2 First writable add		57 Unable to read TOC, PMA or Subcode	46 opc modulation range	22 read with retries	80 initialize pma error
e3 Format track		5a Operator medium removal request	47 opc power range	23 read with ecc correction	81 write pma error
e4 Reserve		63 End of user area encounter on track	48 opc count area full	24 unrecovered read error	82 absorption error
e5 Read track info		64 Illegal mode for this track	50 discinfo	25 invalid block size for read	83 write track error
e6 Write track		65 Verify failed	56 discinfo disc sync	26 buffer underrun	88 initialize write leadin error
e7 Load/Unload		81 Illegal track	57 discinfo atip timeout	27 dummy blocks added	89 write leadin error
e8 Finish track		82 Command now not valid	58 discinfo subcode timeout	28 illegal transfer length	8a initialize write leadout error
e9 Fixation		83 Medium removal is prevented	10 unknown	29 end of medium reached	8b write leadout error
ea Update PMA		84 tray open		2a current program area empty	90 seek error
eb Send absorb control		85 track on disk, not in pma		2b not finalized tracks	91 spinup error
ec Recover		a1 Invalid start-address		2c illegal start address	92 spindown error
ed Write session		a2 Attempt to cross track-boundary		2d illegal stop address	a0 audioplay error
ee Read session info		a3 Illegal medium		2e illegal start track	a1 illegal mode for audioplay
f1 Send service comm		a4 Disc write-protected		2f illegal stop track	a2 track index does not exist
f2 Rec service dat		a5 Application code conflict		30 illegal start index	a3 leadout reached during audio
fc Reset		a6 Illegal block-size for command		31 illegal stop index	b0 no isrc found
fe Write track		a7 Block-size conflict		32 incomplete track exists	b8 no catalog found
ff APV		a8 Illegal transfer length		33 track too short	c0 calibrate error
		a9 Request for fixation failed		34 verify failed	d0 check track error
		aa End of medium reached		35 trk length not mul of packet size	d1 descriptor block timeout
		ab Illegal track number		36 wrong mode for incremental write	d2 out of pregap error
		ac Data track length error		37 current program area not empty	d3 invalid incomplete track
		ad Buffer under run		38 wrong toc mode	d8 verify blank error
		ae Illegal track mode		39 parameter list length error	d9 verify blank EFM found
		af Optimum power calibration error		3a write session invalid field	da verify blank address not found
		b0 Calibration area almost full		3b medium removal requested	
		b1 Current program area empty		3c unrecoverable disc	
		b2 No EFM at search address		3d immediate ready	
		b3 Link area encountered		3e medium not present	
		b4 Calibration area full		40 no control error	
		b5 Dummy blocks added			
		b6 Block size format conflict			
		b7 Current command aborted			
		c0 No barcode available			
		c1 Barcode reading error			
		d0 Recovery needed			
		d1 Can't recover from track			
		d2 Can't recover from prog mem area			
		d3 Can't recover from leadin area			
		d4 Can't recover from leadout area			
		d5 Can't recover from opc area			
		d6 Eeprom failur			

Program Steps:

selftest + audio + reproduction	Read/write	reproduction (weergave)	audio
00 : uit burnin	03 : cdm versie + control cdm	03 : cdm versie + end control cdm	03 : cdm versie + end control cdm
01 : reset	07 : open	07 : open	05 : speed > 1
02 : selftest	40 : speed > 1	30 : start met weergave plaat N = 1	20 : start van sdc444 disk
03 : cdm versie + end control cdm	41 : start	31 : lasttr van weergave plaat	21 : audio volume
04 : test of eprom versie goed is	42 : reserve track 400 blk	32 : apv track 1 N = 1	22 : audio play track 1
05 : speed > 1	43 : write track 400	33 : apv track 3 N = 1	23 : audio play track 8
20 : start van sbc444 disk	44 : flush	34 : open	24 : audio play track 18
21 : audio volume	45 : open	35 : speed > N=2	25 : audio play track 14
22 : audio play track 1	46 : speed > 2	36 : start N=2	26 : audio play track 24
23 : audio play track 8	47 : start	37 : apv track 1 N = 2	60 : open sdc444
24 : audio play track 18	4g : lasttrack	38 : apv track 3 N = 2	61 : start sqew
25 : audio play track 14	49 : write reserved track	39 : open	27 : audio play track 24 SQUEW
26 : audio play track 24	4a : flush	3a : speed > N=4	07 : open
60 : open sbc444	4b : open	3b : start N=4	
61 : start sqew	4c : speed > 1	3c : apv track 1 N = 4	
27 : audio play track 24 SQUEW	4d : start	3d : apv track 3 N = 4	
06 : open met sbc444 of SQUEW	4e : lasttrack	3e : open	
30 : start met weergave plaat N = 1	4f : apv lasttrack		
31 : lasttr van weergave plaat N = 1	50 : apv lasttrack - 1		
32 : apv track 1 N = 1	51 : speed > 2		
33 : apv track 3 N = 1	52 : start		
34 : open	53 : lasttrack		
35 : start met weergave plaat N = 2	54 : apv lasttrack		
36 : lasttr van weergave plaat N = 2	55 : apv lasttrack - 1		
37 : apv track 1 N = 2	56 : fixate		
38 : apv track 3 N = 2	57 : speed > 4		
39 : open	58 : start		
3a : start met weergave plaat N = 4	59 : lasttrack		
3b : lasttr van weergave plaat N = 4	5a : apv lasttrack		
3c : apv track 1 N = 4	5b : apv lasttrack - 1		
3d : apv track 3 N = 4			
3e : open			
			Restart voor 28 42
			71 : Open bij restart
			72 : Start bij restart

3. SERVICE OF THE CDR620/CDR615-USER

- The CDR620/CDR615-User can be set into service mode in two ways:
 - Via RS232
 - Via Keyboard of apparatus
- A service command within service mode is testing of the EEPROM. This testing will be handled in the following way:
 - Read contents of EEPROM-location.
 - Write \$FF to the EEPROM location.
 - Read EEPROM location
 - If written and read data are equal
 - Then
 - Restore contents of EEPROM location.
 - Point to next EEPROM-location.
 - Else
 - Show the next `EEP ERR' in the display.
 - Stop testing EEPROM.

3.1 SERVICING CDR620/CDR615-USER VIA RS232

- The user can connect a PC or a special testboard to the SCI-Bus. When a PC is used a special RS232-to-TTL converter board should be used.
- The following procedure should be followed for servicing the CDR620/CDR615-User:
 - Power -off the CDR620/CDR615.
 - Disconnect the wires between the CDR620/CDR615-User and the CDR-Module.
 - Connect the special RS232-to-TTL converter.
 - Power -on the CDR620/CDR615.
- The user can put the CDR620/CDR615-User into service mode by transferring the command `SERVICE ON' over the SCI-interface.
- You can send this command by starting-up the SERVICE.EXE program on PC.
- You see now an user interface for setting all SCI - commands.
- When you have send the service-start command the information SERVICE will appear in the display. The CDR620/CDR615-User is now in service mode.
- *Don't forget to connect the two cables (9-pins and 7-pins) to the Mono Board.*
 - *Use the original cables from the CDR-Module.*
 - *Disconnect the power supply from the drive and plug the supply into the converter PCB.*
 - *Connect also the RS232 cables to the PC (COM1 or COM2)*
 - *The default setting for the program is COM1.*
 - *When you use com2 start then the program with SERVICE.EXE /COM2.*

-The following commands you can transferred when the CDR620/CDR615-User is in service mode:

- ResetBoard
 - All IC will get a reset (GDIN,ADM0D,DAIO,NPC,uP)

- Play back mode
 - Unlock goes low.(the board goes into slave mode.)
 - This function will only work if we put an EBU signal to connector pos. 1105.2.
 - This mode is actually not usable for service purpose.
- Record AD-DA mode (Analog recording mode)
 - Unlock is high (Crystal is now in fix. mode +/- 50 PPM)
 - Connect an analog source to the input.
 - With the headphone you can hear the audio input.
 - Also XLR analog out is active.
 - This function give no status message to the display.
- Cinch slave mode
 - Unlock goes low.
 - Connect a CD source to Cinch in.
 - You can hear the audio at the analog output or headphone.
 - Also Cinch and XLR EBU is active.
 - If the board doesn't lock ,the message NO LOCK will appear on display.
- XLR slave mode
 - Unlock goes low.
 - Connect a CD source to XLR in.
 - It doesn't matter of you use a Prof. or Consumer source.
 - You can hear the audio at the analog output or headphone.
 - Also Cinch and XLR EBU is active.
 - If the board doesn't lock ,the message NO LOCK will appear on display.
- Cinch SRC mode (Sample Rate Converter)
 - Unlock goes High
 - Connect a digital source from 32khz to 50khz to the Cinch input.
 - You can hear the audio at the analog output or headphone.
 - Also Cinch and XLR EBU is active.
 - If the board doesn't lock ,the message NO LOCK will appear on display.
- XLR SRC mode
 - Unlock goes High
 - Connect a digital source from 32kHz to 50kHz to the XLR input.
 - You can hear the audio at the analog output or headphone.
 - Also Cinch and XLR EBU is active.
 - If the board doesn't lock ,the message NO LOCK will appear on display.
- Toggle Cascade mode
 - This has only affect on the Digital XLR in- and output.
 - The Frequency output will be total the same as the output.
 - You can hear the audio at the analog output or headphone.
 - Also Cinch EBU is active.

- Toggle Deemphasis
 - The board goes now in analog recording mode.
 - With this setting the Deemphasis will be active at the analog output
 - Also the digital outputs will switch.
 - You can hear the audio at the analog output or headphorie.
 - Also Cinch and XLR EBU is active.

- Toggle impedance switch
 - This switch the XLR analog input from +4dbu to -10dbu.
 - This board goes in analog recording mode.
 - You can hear the audio at the analog output or headphone.
 - Also Cinch and XLR EBU is active.

- Eeprom test
 - This will test the EEPROM

- EEPROM Clear
 - Clear the internal eeprom

- ROM-Version
 - Show the ROM-version number of the CDR620/CDR615-User.

- The command 'SERVICE.OFF' is the command to leave the service mode and the CDR620/CDR615-User will continue in normal mode.

- | | |
|----------------------|-------------------------|
| FINALIZE-key | Toggle impedance switch |
| PRESET-key | Eeprom Test |
| TIME-key | Eeprom reset |
| COPY-key (CDR620) | CDR-Module diagnostic. |
| MONITOR-key (CDR615) | CDR-Module diagnostic. |

4. SHOW TEXT FOR SERVICE COMMANDS

- ServiceOn command
 - The display shows the text 'SERVICE' in the digits.
- ServiceOff command
 - the display will show that text what will be shown operating in normal mode.
- Reset Board command
 - The display will show the text 'RST BRD' in the digits.
- Playback command
 - The display shows the text 'PLAYBACK' in the digits.
- AD-DA recording command
 - The display shows the text 'RECORD' in the digits and the ANALOG label is lighting up.
- Slave Cinch recording command
 - The display shows the text 'CIN REC' in the digits.

- Slave XLR recording command
 - The display shows the text 'XLR REC' in the digits.

- SRC Cinch recording command
 - The display shows the text 'CIN REC' in the digits and the label SRC is lighting up.

- SRC XLR recording command
 - The display shows the text 'XLR REC' in the digits and the label SRC is lighting up.

- Toggle Cascade command
 - The display will either show the text 'CASC ON' or the text 'CASC OFF'.

- Toggle Deemphasis command
 - The display will either show the text 'EMPH ON' or the text 'EMPH OFF'.

- Toggle Impedance Switch
 - The display will either show the text 'SENS +4' or the text 'SENS - 10' and the label ANALOG is lighting up.

- Eeprom test command
 - The display will show the text 'EEP xxx' ,where xxx is the eeprom byte to be tested.

- Eeprom Clear command
 - The display will show the text 'RST EEP'.

- ROM-Version of CDR620/CDR615
 - The display will show the text 'VERS XX'.

- Diagnostic of the CDR-Module
 - The display will show the text 'DIAGNOST'.
 - OK —> CDD0000
 - NG —> CDD***** (***** : ERROR CODE)

3.2 SERVICING CDR620/CDR615-USER VIA KEYBOARD

- The following procedure should be done to set the CDR620/CDR615-User in service mode:
 - power Off the CDR620/CDR615.
 - Disconnect the wired remote.
 - Press simultaneous the RECORD- and RECORD MUTE key. And wait 15sec or more for initialize of service mode.

- The display shows the text 'SERVICE' in the digits. This indicates that the CDR620/CDR615-User is in service mode.

- The following keys are used to execute an additional service command:

RECORD-key	Show ROM-version of the CDR620/CDR615-User. This key is only valid after starting up in service mode.
STOP-key	Service off (leaving service mode)
OPEN/CLOSE-key	Reset Board
PLAY-key	Playback mode
Pause-key	AD-DA recording mode.
TRACK INC-key	Slave Cinch mode.
NEXT-key	Slave XLR mode.
PREVIOUS-key	SRC Cinch mode.
INPUT-key	SRC XLR mode.
Search REVERSE-key	Toggle Cascade mode.
Search FORWARD-key	Toggle Deemphasis

1.8.2 MONO BOARD

1. REQUIREMENTS

The instruments used to make this controle prescription are listed below :

- Audio precision
- Oscilloscope
- A voltmeter

2. GENERAL OVERVIEW

You can see in figure 1 a global block diagram of the CDR620/CDR615. The most important blocks are discussed later in this report.

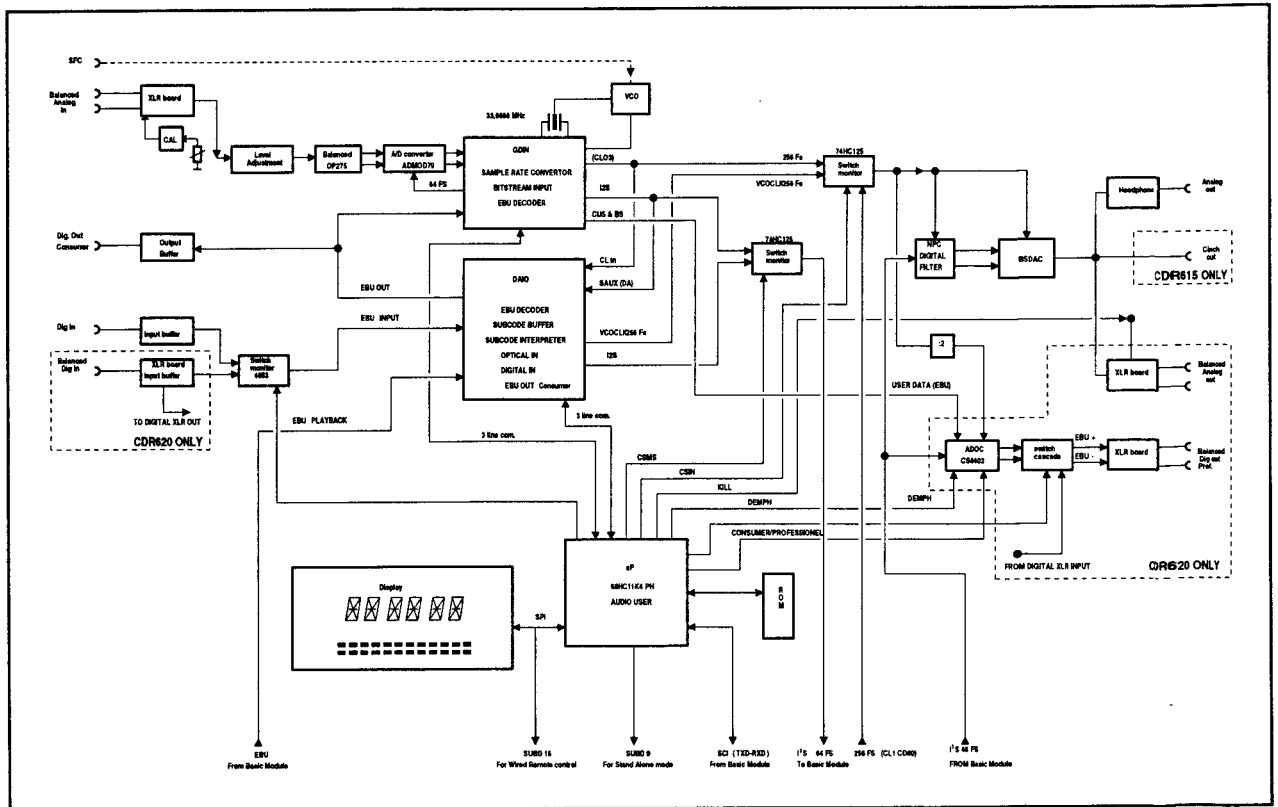

Figure 2.2

3. XLR BOARD

3.1 INPUT CIRCUITRY

The XLR board has an balanced analog input circuitry, the signal will be transferred to a single ended signal that goes to the level adjustment point. The impedance switch (nr.1 fig.3.1.a) on the XLR input is controlled depending on the microprocessor, which will switch the state by preset mode or when the input signal is to big or to small. On the XLR inputs, there is also a trimmer, which controls the balance between the inputs (nr.2 fig.3.1.a).

It's necessary to adjust these trimmers, so that there is a balance between the inputs. The differential amplifier converts from the balanced signals to a single ended signal (nr.3 fig.3.1.a). At the end there's a buffer, this element is placed for buffering the circuitry and for low output resistance which will give a better performance in crosstalk and less distortion. (nr.4 fig. 3.1.a)

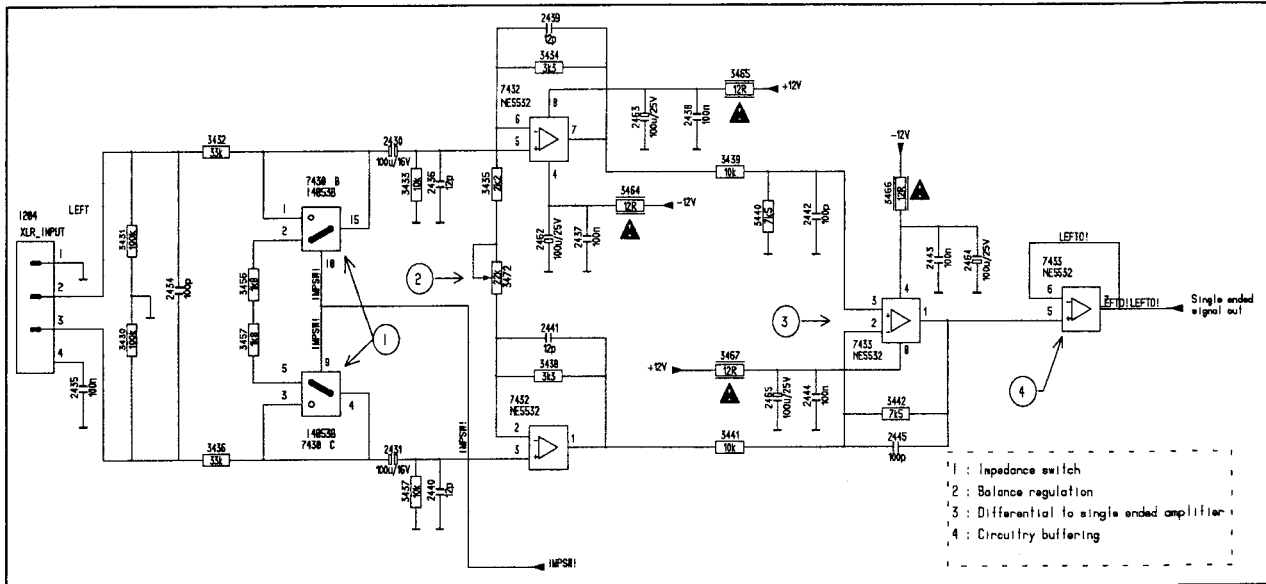

Figure 3.1.a

MEASUREMENTS

In figure 3.1.b. we have an analog balanced input signal of 1 kHz 4.887 Vrms. Channel 1 and 2 are measured on the 2 signal pins of the XLR input plug (pin 2 and 3),

channel 3 is measured on the connector to the level print. Note that the single ended signal coming from the XLR board is only 0.5 Vrms (± 0.1 dB) in amplitude.

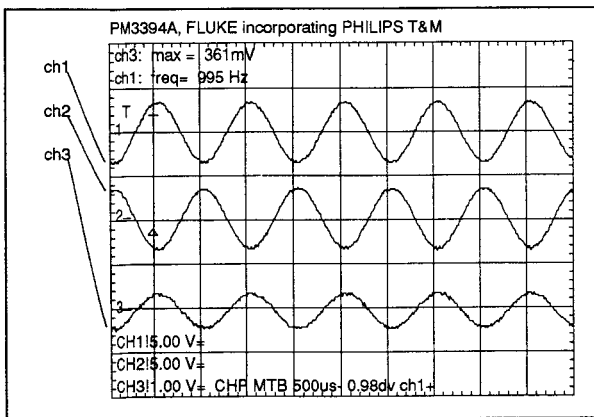

Figure 3.1.b

ADJUSTMENTS

The potentiometer (nr.2 in figure 3.1.a) has to be adjusted for a well balanced analog input circuit. Here we use the Audio Precision, you have to give an input signal for the CDR of 1 kHz +16 dBu, you reset the GDIN with the software and you measure the voltage on the

input connector of the level print (with an voltmeter), this has to be ± 500 mV rms (± 0.1 dB). When you give the command "Toggle imp_switch", the input has to be reduced till 2 dBu input, and must also give ± 500 mV rms (± 0.1 dB). This has to be done for both channels.

3.2 OUTPUT CIRCUITRY (CDR620 ONLY)

The output circuitry is analog here we make from the single ended signal a balanced signal. (fig.3.2.a) The single ended input signal will be first amplified with an amplifier with very low distortion because the XLR output has a voltage of ± 4.88 Vrms (nr.1 fig.3.2.a). For making the signal balanced, the signal is fed to an inverting

and a non - inverting amplifier. Eventually the signal is fed to a buffer for the output (nr.2 fig.3.2.a). At the end of the circuitry we see 2 FET's, these will short the outputs when the base of the FET is positive ($\approx +12$ V), the analog kill (nr.3 fig.3.2.a).

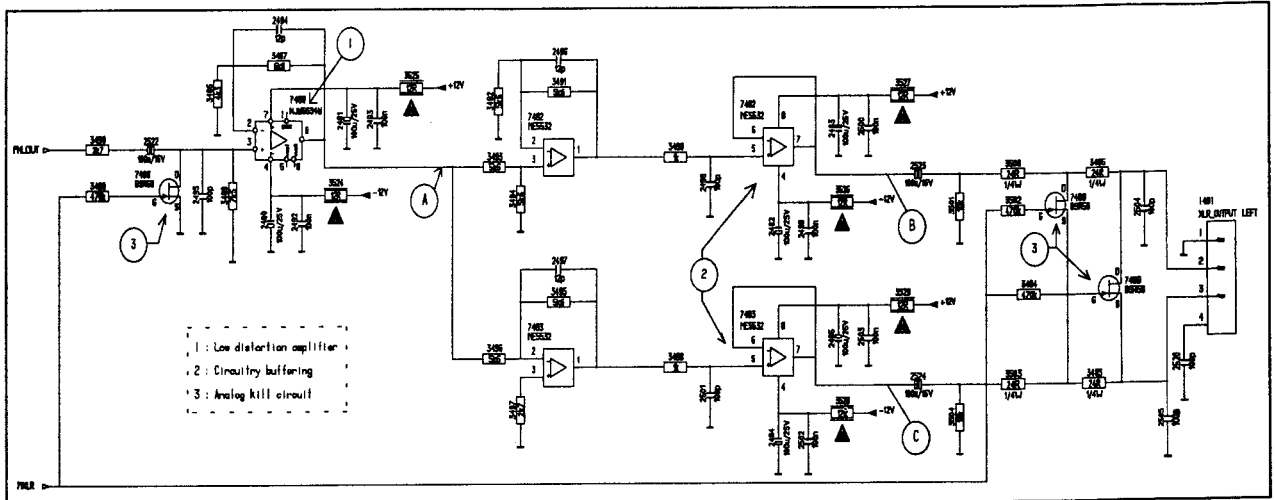

Figure 3.2.a

MEASUREMENTS

Connect the digital input and configure the Audio Precision for a digital output of 1 kHz 100% full scale amplitude. Put the unit in "src_xlr" then you must measure on the points A, B and C 3.65 Vrms. On the points D and E of figure 3.2.c you must measure 0.98 V rms and on points F and G 1.95 V rms.

In figure 3.2.b. we have an single ended input signal of 1 kHz ± 2.61 V. Channel 1 is measured after the first opamp after the BSDAC (on pin 1 of the OP275 IC fig.3.2.c). Channel 2 and 3 are the balanced outputs measured on the pins 2 and 3 of the XLR plugs.

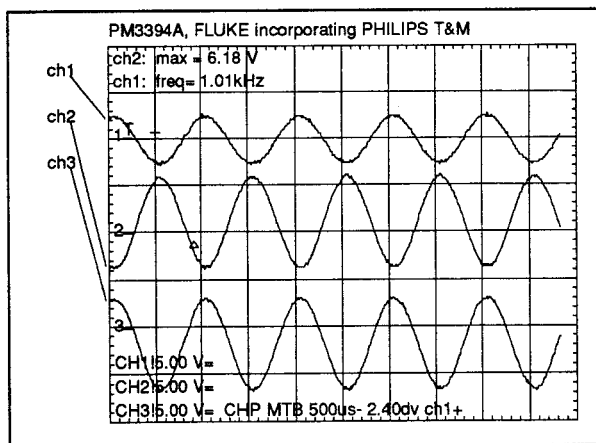

Figure 3.2.b

CHANNEL 1 : SINGLE ENDED SIGNAL MEASURED AFTER THE FIRST OPAMP AFTER THE BSDAC

CHANNEL 2 : IS SIGNAL ON BALANCED OUTPUT (POSITIVE SIDE) AMPLITUDE IS +6.18 V AND -3.75 v

CHANNEL 3 : IS NEGATIVE SIDE OF BALANCED OUTPUT, THE AMPLITUDE IS +3.25V AND -6.59V

This circuit (fig 3.2.c) after the BSDAC is a filter. The first filter is a low pass filter with a turn point on a frequency of 88 kHz. The second one is a notch filter on a frequency of 340 kHz because of the dither frequency of the BSDAC.

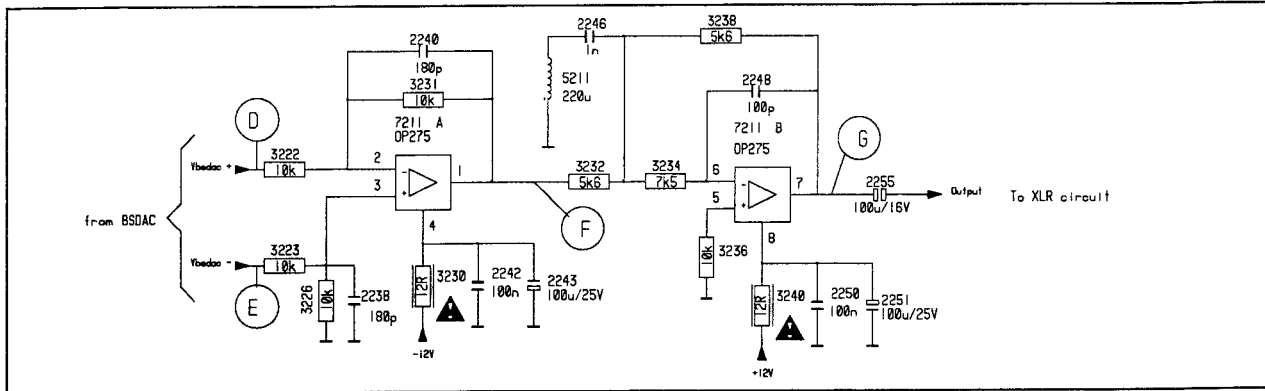
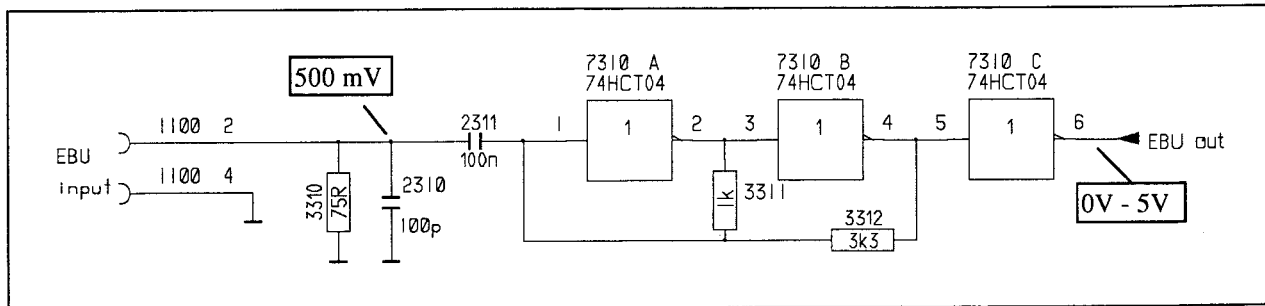

Figure 3.2.c

4. CINCH DIGITAL INPUT/OUTPUT

The digital input coming from the cinch connector is much lower in level than the TTL logic levels. For this case there is used the slicer system (see fig 4.1), to convert to TTL logic.



Figuer 4.1

The frequency of the EBU signal is in the range of the 5.6 MHz. (see fig. 4.2), the level of the cinch input and output is ± 500 mV. Notice in figure 4.2 that the amplitude of channel 2 is 5 V/div see also IEC 958.

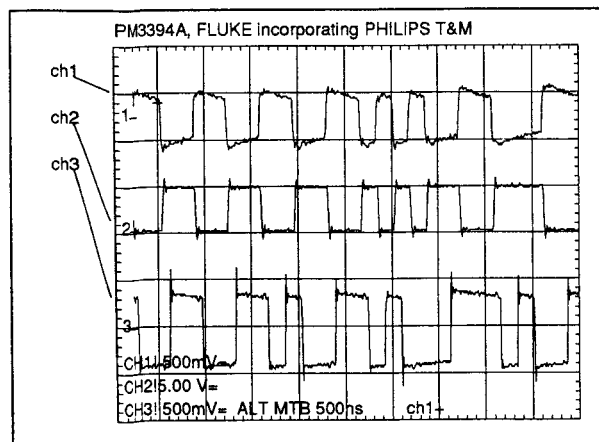

CHANNEL 1 : EBU IN ON CINCH INPUT CONNECTOR

CHANNEL 2 : EBU IN ON DAIO IC

CHANNEL 3 : EBU OUT ON CINCH CONNECTOR

Figure 4.2

5. ANALOG INPUT BEFORE AD CONVERSION

The circuit in figure 5.1 makes from the single ended input signal, a balanced analog output signal for the AD convertor. The circuit has a gain of 1 and is only mentioned to convert single ended to balanced and some filtering.

MEASUREMENT

If we give an analog input signal of 1 kHz 16 dBu, then we get at the output connector (the input connector of the circuit), a voltage of 1.13 Vrms, this voltage must be the same at points A,B and C all measurements are ± 0.1 dB.

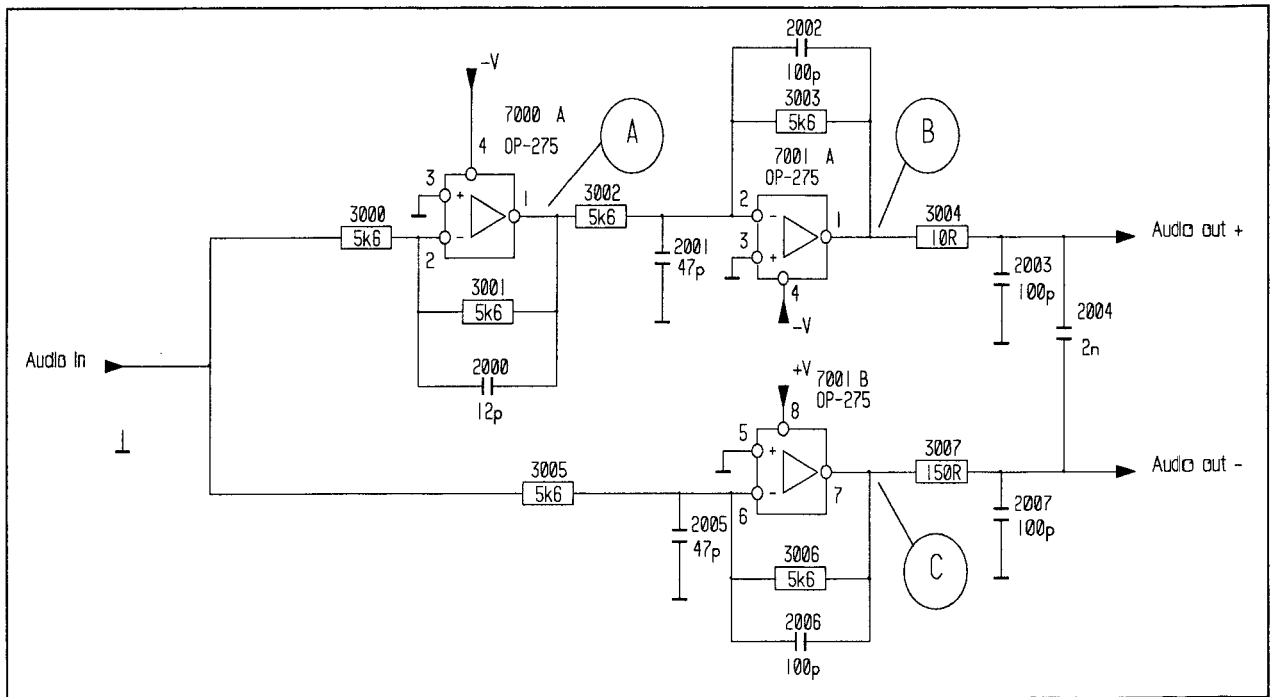
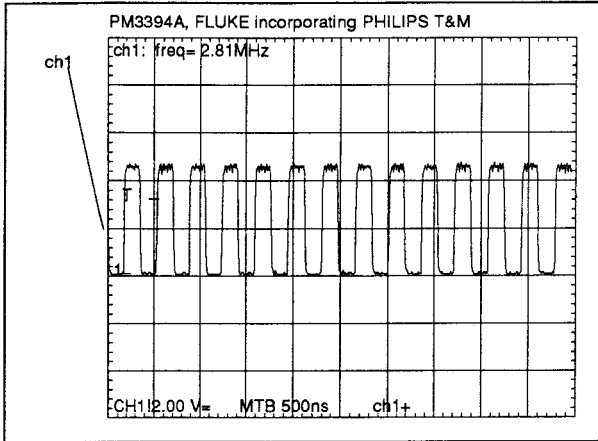

Figure 5.1

6. A/D CONVERTOR ADMOD79

The ADMOD 79 A/D convertor is a bitstream sigma delta analog/digital convertor. The analog inputs of the convertor are balanced signals (see fig 6.1.2). When the start up of the board is good, there has to be on pin 3 the sample clock, this has a frequency of 2.82 Mhz which is

64 times fs. (see fig. 6.1) This signal is for the synchronization of the bitstream data transfer to the GDIN. The bitstream data has 2 separate outputs 1 for the left - and the other for the right channel.



CHANNEL 1 : SAMPLE CLOCK FROM GDIN 2.82 MHZ (FOC PIN 56 OF GDIN)

Figure 6.1.1

It is very important for the A/D convertor that all supply voltages are present and correct (see p 27), when there is a bad function of the A/D convertor, first check the sample clock and the supply voltages.

The reset (SRSTN!) is connected to the "CALIB" input of the ADMOD, and is active low. Because all of the

opamps have a DC output, the ADMOD will calibrate itself to eliminate the offset when there has been a reset. Notice that the power down pin (PWD pin 9) has to be connected to the ground otherwise the ADMOD goes in to power down mode and will not operate anymore.

The analog input for the AD convertor is a balanced signal, the data output is a bitstreamed output where the sample clock takes care of the synchronization.

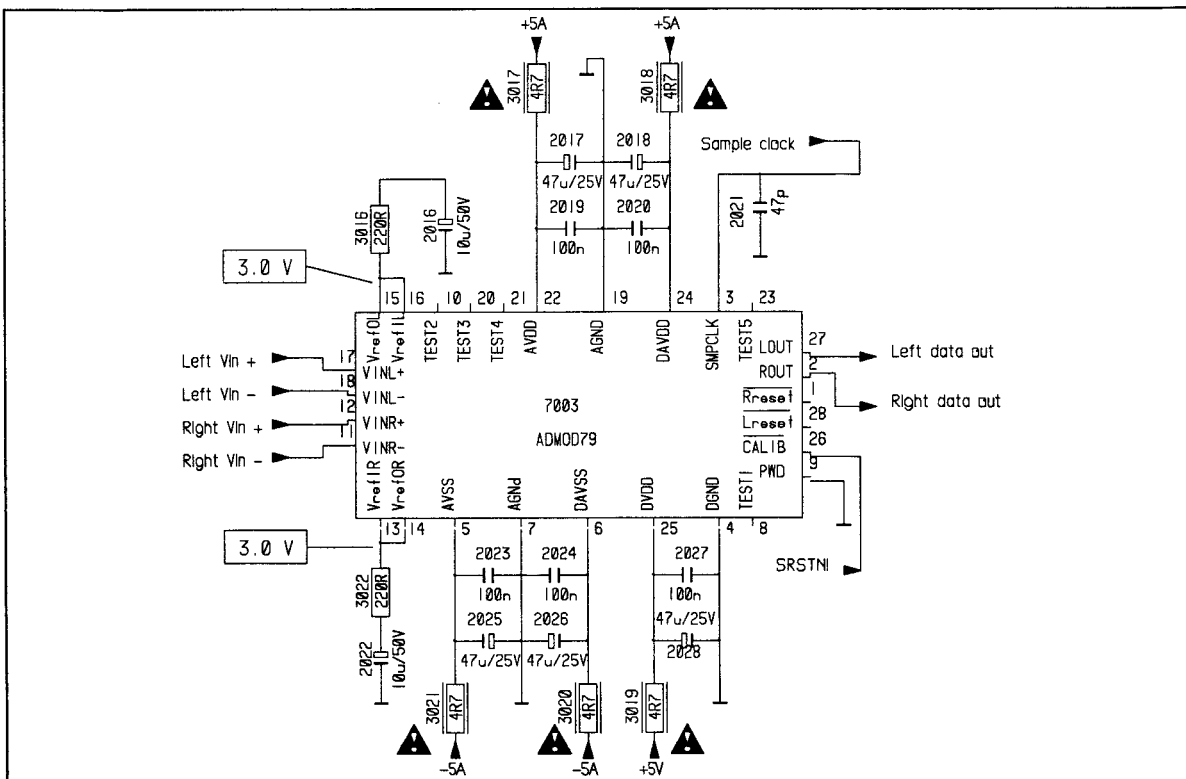

Figure 6.1.2

7. GDIN

The GDIN is component with a large scale of possibilities, it has a several different modes in which it can be switched. The GDIN is able to fully digitally convert t

rates in the range of 15 to 50 kHz to a rate of 44.1 kHz. The GDIN also contains all the digital electronics for Bitstream A/D and D/A conversion.

7.1 OPERATION MODES OF GDIN

7.1.1 SAMPLE RATE CONVERSION MODE (SRC)

In the sample rate conversion mode, GDIN converts digital audio signals at sampling frequency f_{in} to the output sampling frequency f_{out} , determined by the crystal. The range of input frequencies for a given output frequency is given in table 7.1.

Output frequency (examples)	I ² S input	AES/EBU input
48 kHz	13 - 83 kHz	16 - 54 kHz
44.1 kHz	12 - 76 kHz	15 - 50.4 kHz
32 kHz	9 - 55 kHz	12 - 36 kHz

tabel 7.1

7.1.2 SLAVE - VCO MODE

In the slave - VCO mode, GDIN passes an exact copy of the incoming samples to the output. The output sampling rate is tracking any input sampling rate within the

frequency range of the additional external VCO. This mode is not used for the CDR620/CDR615.

7.1.3 SLAVE - Xtal MODE

In the slave Xtal mode, GDIN passes an exact copy of the incoming samples to the output. By means of a varicap across the Xtal (see figure 7.1.5), the input rate

can be tracked in a frequency range of ± 150 ppm around the nominal output sampling frequency. (see figure 7.1.3)

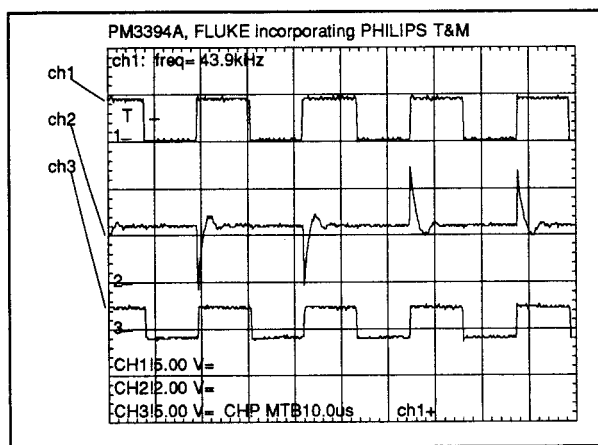

Figure 7.1.3

CHANNEL 1 : THIS IS THE CLOCK COMING FROM THE EBU SIGNAL, OR THE STUDIO CLOCK

CHANNEL 2 : IS THE SIGNAL THAT TRACKS THE CRYSTAL ON THE INCOMING WORD CLOCK FROM EBU OR STUDIO CLOCK. THIS SIGNAL WILL ONLY BE LIKE THIS IN SLAVE MODE (NR.1 FIG.4.1.5)

CHANNEL 3 : SRWS, IS THE WORD CLOCK COMING FROM THE GDIN WHO GET THIS SIGNAL OUT OF THE I²S SIGNALS

7.1.4 A/D - D/A MODE

In the A/D-D/A mode, GDIN supports the realization of A/D and D/A conversion, according to the Bitstream principle.

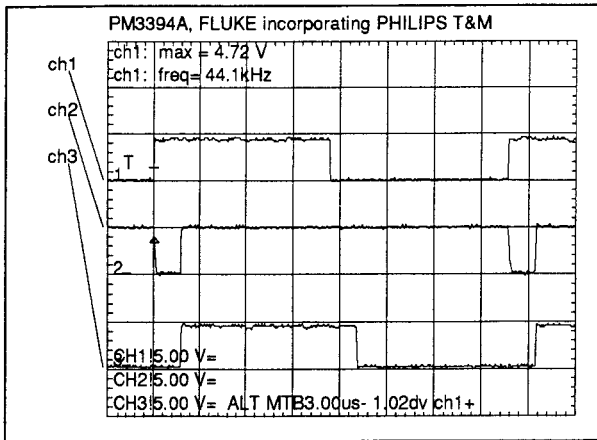

CHANNEL 1 : IS THE CLOCK COMING FROM THE EBU SIGNAL, OR THE STUDIO CLOCK

CHANNEL 2 : IS THE SIGNAL THAT TRACKS THE CRYSTAL ON THE INCOMING WORD CLOCK FROM EBU OR STUDIO CLOCK

CHANNEL 3 : SRWS IS THE WORD CLOCK COMING FROM THE GDIN, WHO GETS THE SIGNAL OUT OF THE I²S SIGNAL

Figure 7.1.4

7.1.5 OPERATION OF CRYSTAL TRACKING

In the schematic you see that we can lock the signal from the GDIN to two signals, the studio clock (FS!) or the I²S clock that is extracted from the EBU input (FOW!), it is the micro processor who determines the position of the switch. These signals are added to a phase comparator, which gives a signal out in function of the difference in phase of the two incoming clocks (see fig. 7.1.3). When the UNLOCK! signal is low (nr.2 fig.7.1.5), then the crystal will track on the clock coming from the EBU or studio clock. The signal coming from the phase

comparator (nr.1 fig.7.1.5) goes to a differential amplifier (nr.4 fig.7.1.5), which gives a signal in function to a referention voltage determined by the first opamp. This voltage will control the varicap (nr.3 fig.7.1.5), and thus also the crystal. When the UNLOCK! pin is high, the crystal will not be locked on a incoming clock. The crystal will oscillate at the fixed frequency ± 50 ppm. Notice that this frequency can be measured on the CL01 pin of the GDIN (pin 27)

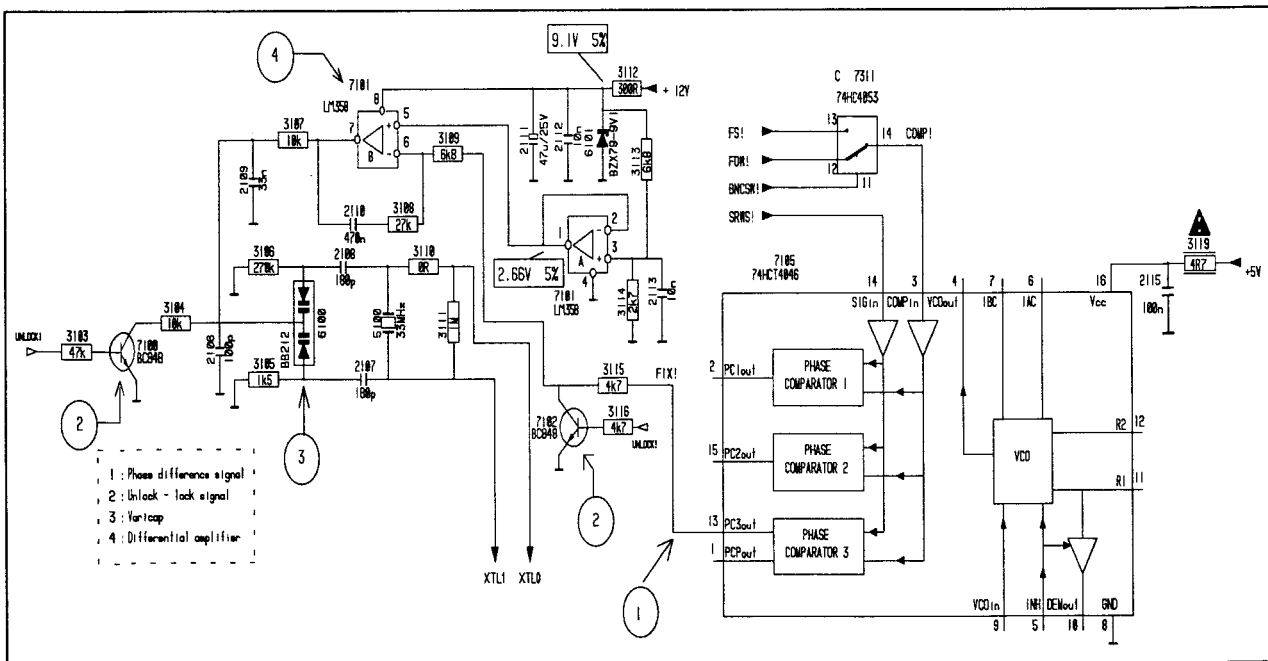

Figure 7.1.5

7.2 COMMUNICATIONS

7.2.1 WITH THE MICROPROCESSOR

The GDIN can be programmed or communicate with the microprocessor by 3 wires : GDINLD!, GDINDA! and GDINCL!.

The GDINLD! is the load line which says if we want to read or write, if the line is high, we are in write mode and

if low the GDIN is in read mode.(input line) The GDINDA! is the data line, input output. The GDINCL! is the bit clock line for the GDIN.(output line).(see fig.7.2.1)

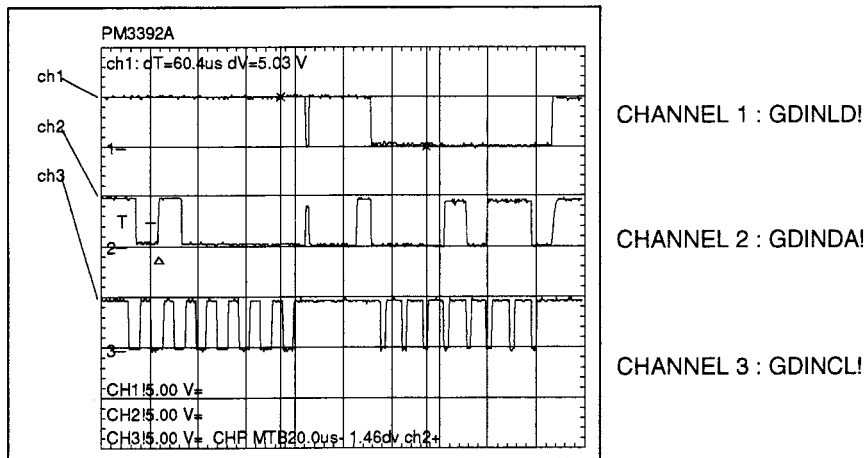

Figure 7.2.1

7.2.2 I²S OUTPUT

The I²S output is used for the digital audio output. The communication is a 3 line communication. The digital audio output word select (f_{out}) SRWS has a frequency of 44.1 kHz. The output bit clock SRCL has a frequency of $48 \times f_{out} \approx 2.1 \text{ MHz}$ (see fig 7.2.2.1). Note that the

SRDA! coming from the I²S of the GDIN is half a clock out of phase(see fig 7.2.2.2), this is why we shift the data with the circuit as in fig. 7.2.2.3 on the 4 times the clock frequency DO2C!.

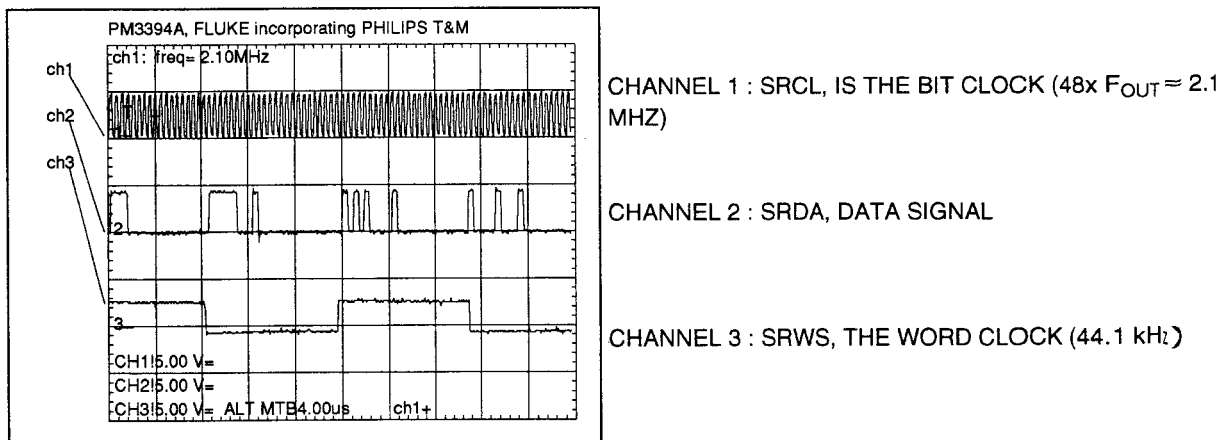
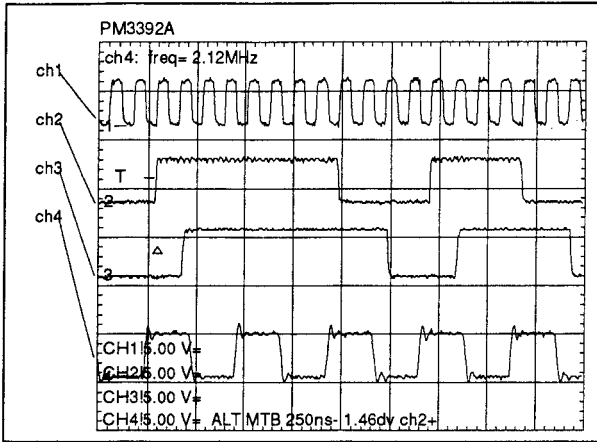

Figure 7.2.2.1



CHANNEL 1 : DO2C! : THIS IS 4 TIMES THE I²C CLOCK

CHANNEL 2 : SRDA! : THIS DATA HAS TO BE SHIFT OVER 1/2 OF THE I²S CLOCK

CHANNEL 3 : GDDA! : THIS IS THE SHIFTED I²S DATA

CHANNEL 4 : SRCL! : THIS IS THE I²S CLOCK.

Figure 7.2.2 2

The circuit in fig. 7.2.2.3 will shift the data half a clock of the I²S out clock, this because the data signal has to be stable on the rising edge of the clock. The signal DO2C!

is 4 times the I²S clock frequency (nr.1). So the output (nr.3) will be shift 1 clock (DO2C!) period, which equals quarter of the I²S clock.

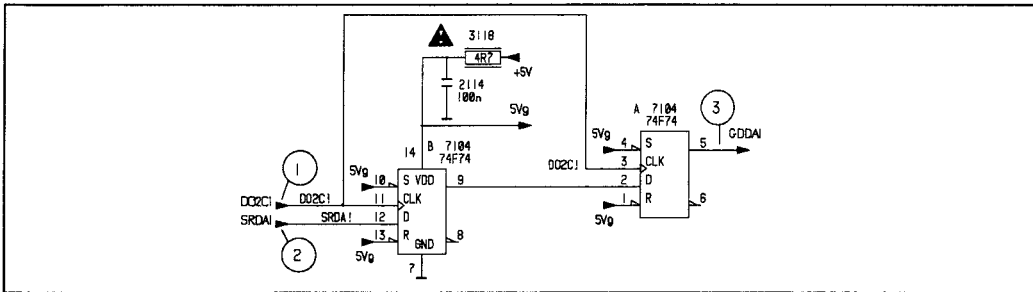

Figure 7.2.2.3

8. DAIO TDA1315

The Digital Audio Input/Output circuit is a complete transceiver for biphase-mark encoded digital audio signals that conform to the SPDIF standard. In the receive mode, the device adjusts automatically to one of the three standardized sample frequencies (32, 44.1 or 48 kHz), decodes the input signal and separates audio and control data. A clock signal of either 256 or 384 times the sample frequency is generated to serve as a master clock signal in digital audio systems. In the transmit mode,

the device multiplexes the audio, control and user data and encodes it for subsequent transmission via a cable or optical link.

This component also communicates with the micro-processor by a 3 wire communication, (see fig. 7.2.2.1) (lines CDAIDA!, CDAICL! and CDAILD!)

The DAIO can take EBU signal in (see fig. 4.2), interpret the subcode and send EBU out and I²S out (see fig 8.1).

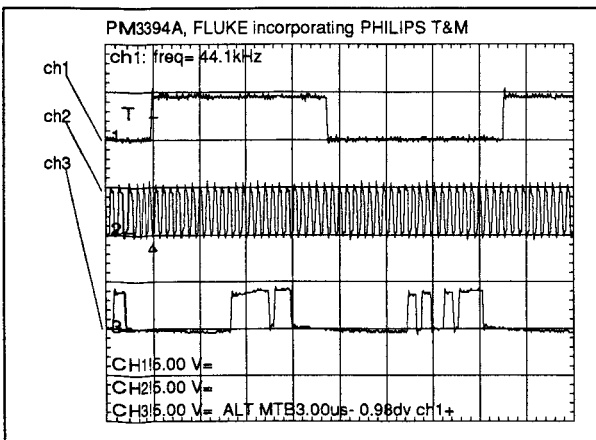

CHANNEL 1 : WORD CLOCK 44.1 kHz

CHANNEL 2 : CLOCK LINE (2.1 MHz SQUARE WAVE)

CHANNEL 3 : DATA LINE

Figure 8.1

9. NPC / BSDAC

The NPC is a digital filter and gets its communication with the microprocessor done with almost the same lines as the GDIN, GDINLD!, GDINDA! and CL/NPC!. The input concerning the audio data, the NPC gets from the I²S input on the monoboard, FDA!, FCL! and FWS1.

The resulting data (filtered) goes to the BSDAC by the lines DOR!, DOLI, BSWS! and BSCL!. This is almost the same as the I²S communication, only the data path is split into the left and right channel. (see fig.9.1)

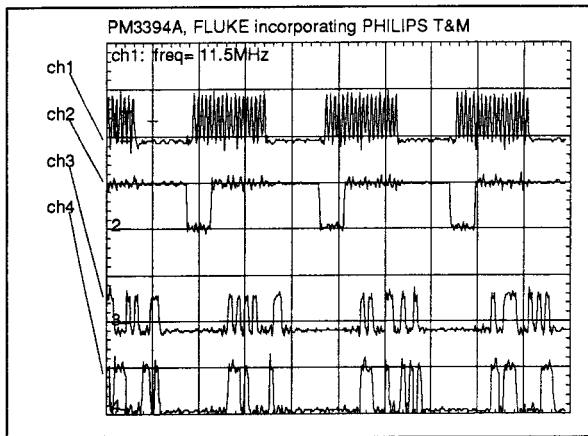

CHANNEL 1 : BSCL! THIS SIGNAL CONTAINS THE CLOCK SIGNAL WITH A FREQUENCY OF 11.4 MHz

CHANNEL 2 : BSWS! REPRESENT THE WORD CLOCK WITH A FREQUENCY OF 352 kHz $\approx 8 \times F_s$

CHANNEL 3 : DOLI! CONTAINS THE AUDIO DATA FOR THE LEFT CHANNEL

CHANNEL 4 : DOR! CONTAINS THE AUDIO DATA FOR THE RIGHT CHANNEL

Figure 9.1

So the BSDAC gets its data bitstream I²S in, and gives a balanced analog signal out. The NPC and the BSDAC have an internal clock determined by MCLK! of 11.2896 MHz. square wave. (see fig. 9.2)

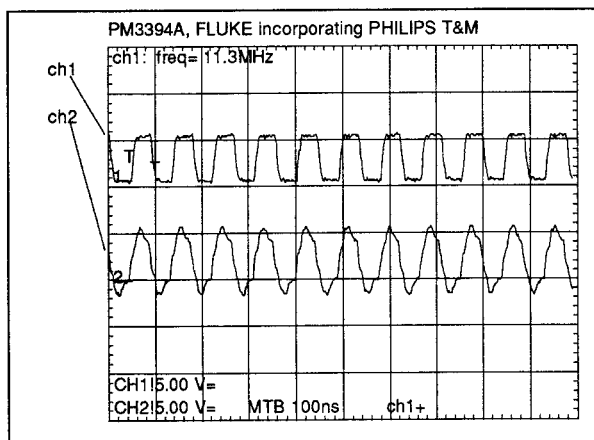

CHANNEL 1 : MCLK! IS THE MASTER CLOCK FOR THE DAC, ON A FREQUENCY OF 11.2896 MHz

CHANNEL 2 : GDMCLK! IS THE DAIO MASTER CLOCK ALSO ON 11.2896 MHz

Figure 9.2

10. MICROPROCESSOR

The microprocessor is the heart of the CDR, the micro-processor functions are :

- communication with the display / wired remote
- controls all analog switches
- 3 line communication / programmation of the :
 - GDIN
 - NPC
 - DAIO
- handling the RC5 communication
- communication with CDD2000 module

10.1 DISPLAY COMMUNICATION

For the display communication we have to make a difference for the case without wired remote and with wired remote, because the display select line will have different patterns. When there is NO remote attached the communication goes as follows : there is a display clock

(a square wave) with a frequency of 125 kHz, a display select line and an acknowledge line which is asserted when the received data has been accepted. (see fig. 10.1.1)

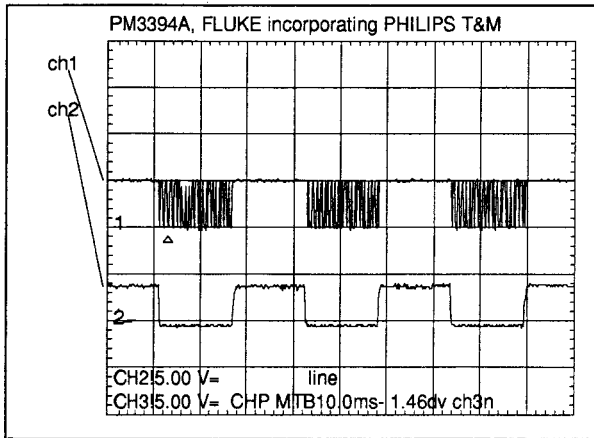

CHANNEL 1 : DACK

CHANNEL 2 : DSEL IS THE DISPLAY SELECT LINE AND HAS A FREQUENCY OF 32 Hz WHEN NO REMOTE ATTACHED.

Figure 10.1.1

When there is a remote attached the communication goes as follows : there is a display clock (a square wave) with a frequency of 125 kHz, a display select line which is

in this case 1/3 from the updating of the remote display, and an acknowledge line which is asserted when the received data has been accepted. (see fig. 10.1.2)

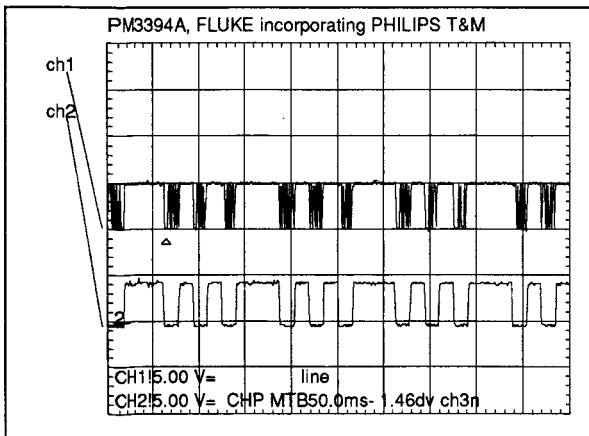

CHANNEL 1 : DACK

CHANNEL 2 : DSEL THIS SIGNAL SHOWS THAT THE UPDATING OF THE DISPLAY IS 1/3 FROM THE UPDATING OF THE REMOTE DISPLAY

Figure 10.1.2

10.2 MICROPROCESSOR OPERATION

The E signal of the microprocessor is a helping signal to make the read and write lines for memory and buffers. When this signal is not present, the board will not operate. The E - signal has to be a square wave of 4 MHz clock frequency.

The first figure (fig.10.2.1) is the same E signal but sometimes we got a frequency change in the signal ???

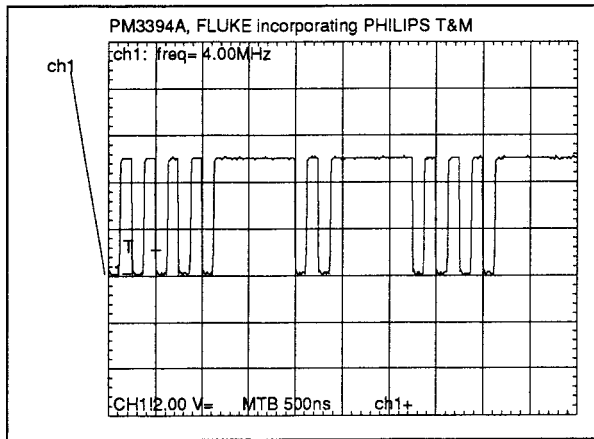

Figure 10.2.1

The normal E signal should look like the following picture

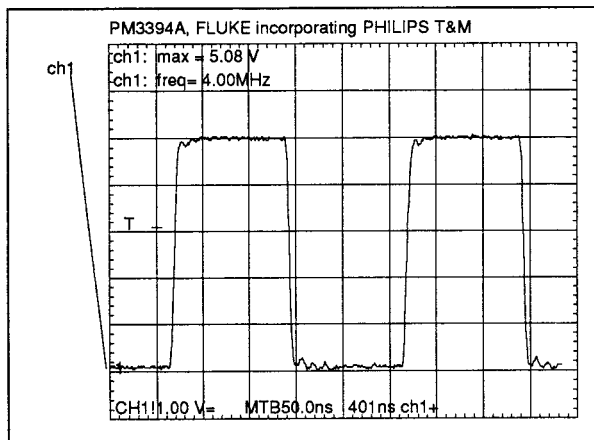
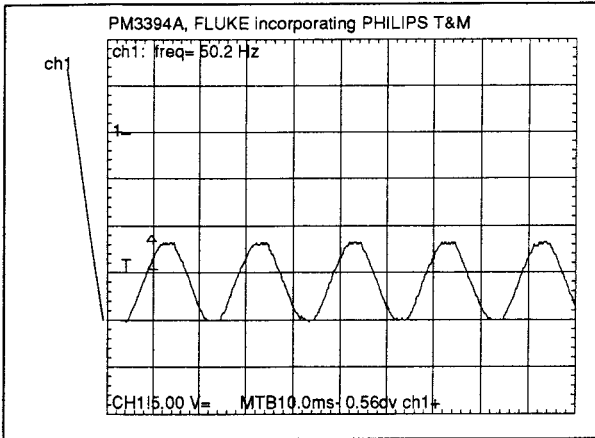

Figure 10.2.2

11. SUPPLY MEASUREMENTS

a) VFILIR, VFIL2R



CHANNEL 1 : VFILIR, VFIL2R THIS IS THE VOLTAGE FOR THE FILAMENTS OF THE FTD. THE VOLTAGE IS $-17\text{ V} \pm 3.5\text{ V}$ WITH A FREQUENCY OF $\approx 50\text{ Hz}$

b) REFFIL

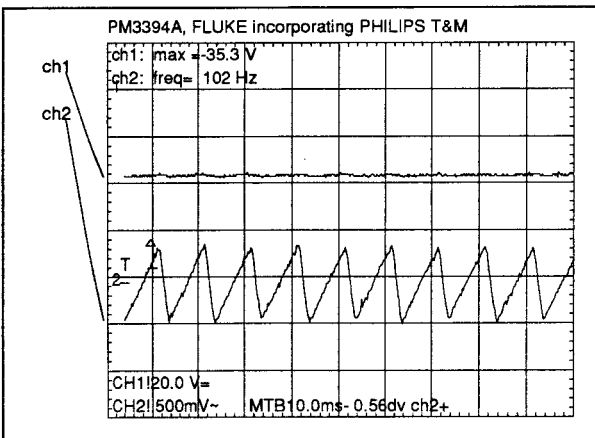

CHANNEL 1 : DC VOLTAGE $\approx -35\text{ V}$

CHANNEL 2 : AC VOLTAGE 100 HZ TRIANGLE $\pm 500\text{ MV}$

c) VFTD, POFF

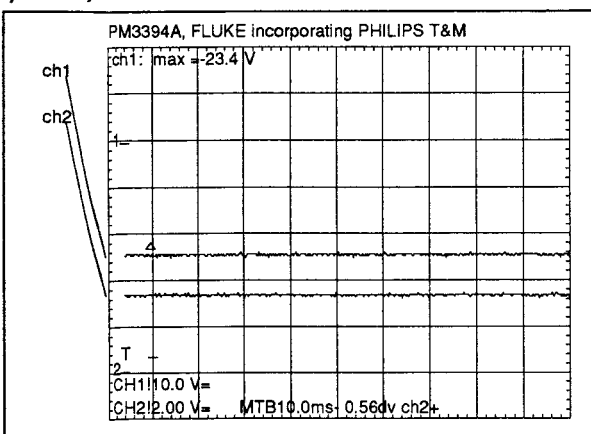

CHANNEL 1 : VFTD VOLTAGE $\approx -23\text{ V}$ THIS IS THE VOLTAGE FOR DRIVING THE FTD SEGMENTS.

CHANNEL 2 : POFF VOLTAGE $\approx 3.5\text{ V}$

d) SUPPLY VOLTAGES

In the following table you see all the DC supply voltages and ripples from the monoboard CDR620. All measurements are done on the supply of the given components,

this always on the side to the IC. If there's a measurement on a capacitor done, it will always be on the positive side of the capacitor.

Component number	Voltage (Volts)	Ripple (mV)	Resolution
2382+	5.17	±15	
2383+	5.17	±25	
2381+	5.17	±25	
2394+	5.25	+10 -5	
2400+	not present	+10 -5	
2152	5.1	±15	
3017	4.8	±10	
3018	5	±30	
3019	5.15	+20 -10	
3020	-5	+50 -40	
3021	-4.8	+30 -25	
3100	5.2	±10	
3101	5.2	±10	
3102	5.2	±10	
3112	12	+40 -20	
3118	5.2	±24	
3119	5.2	±10	
3150	5.2	±20	
3151	not present		
3158	3.9	±10	
3201	5.2	±10	
3210	5.2	±20	
3214	5.2	±20	
3220	5.2	±20	
3221	5.1	±15	
3228	-12	+72 -40	
3230	-12	+50 -22	
3240	12	30 + -20	
3241	12	±20	
3282	12	+35 -15	
3284	12	±20	
3285	-11.8	+60 -40	
3300	5.3	±10	
3301	5.2	±20	

Component number	Voltage (Volts)	Ripple (mV)	Resolution
3313	5.2	±20	
3314	5.2	±20	
3343	5.2	+30 -16	
3380	5.25	±30	
3381	5.1	±20	
3382	5.15	±25	
3383	5.2	±20	
3384	5.2	±20	
3385	5.2	±15	
3389	5.25	+70 -80	
3391	5.15	+10 -5	
3392	5.2	+10 -5	
3393	5.2	±20	
3404	5.15	+55 -40	
3410	5.25	±10	
3411	5.05	+15 -5	
3412	5.1	±10	
3413	5.25	±10	
3427	5.25	±10	
3464	-11.8	+40 -20	
3465	12	±5	
3466	-11.8	+40 -20	
3467	11.9	+10 -5	
3468	-11.8	+40 -20	
3469	11.8	+10 -5	
3470	-11.8	+40 -20	
3471	12	+30 -10	
3524	-12	+60 -35	
3525	12	+35 -15	
3526	-11.8	+35 -25	
3527	12	+30 -20	
3528	-11.8	±30	
3529	12	±20	
3530	-12	±30	

Component number	Voltage (Volts)	Ripple (mV)	Resolution
3531	12	±20	
3532	-11.8	±35	
3533	12	+30 -15	
3534	-11.8	±30	
3535	11.8	±15	
7003-25	5.1	±30	
7003-24	5.1	+48 -62	
7003-22	4.8	+32 -20	
7003-19	0	±10	
7000-8	5.4	±2	
7001-8	6		
7002-8	6		
7003-9	0	±20	
7000-4	-6.4	±2	
7003-7	0	±16	
7001-4	-6.4		
7003-6	-5	±56	
7002-4	-6.4		
7003-5	-4.8	±36	
7004-3	5.1	+20 -10	
7005-3	-5.2	+20 -10	
7004-1	12	±50	
7005-2	-15	+60 -80	
7103-39	5	+150 -300	
7103-19	4.8	±20	
7103-17	0	±20	
7103-14	4.8	+60 -85	
7103-13	0	±20	
7103-12	0	±20	
7103-11	4.8	+70 -90	
7103-8	0	±10	
7103-7	5	+180 -210	
7103-3	5	+28 -40	
7103-1	0	±10	
7311-16	5.2	±20	
7390	5.17		
7386	5.17		

Component number	Voltage (Volts)	Ripple (mV)	Resolution
7430	5.76		
7431	5.76		
7381	5.18		
7391	5.09		
7394	5.09		
7414	5.17		
7412	5.18		
7200	4.77		
7410	4.96	+15 -10	
7383	5.16	+15 -10	
7413	5.16		
7411	5.00	+10	
7393	5.09		
7392	5.09		
7384	5.16		
7385	5.17		
7387	5.17		
7310	5.05		
7311	5.18		
7104	5.18		
7301	5.14		
7105	5.18		
7340	5.17		
7483-4	-12	+40 -30	
7483-8	+12	+10	
7482-4	-12	+40 -25	
7482-8	+12	+10	
7485-4	-12	+40-25	
7485-8	+12	+10	
7484-4	-12	+40-25	
7484-8	+12	+10	
7480-4	-12	+40-25	
7480-8	+12	10	
7481-4	-12	+40-25	
7481-8	+12	+10	

1.8.3 POWER SUPPLY

1. GENERAL WORKING

See schematic page 1-47 – 48.

1.1 POWER CONVERSION

1.1.1 PRIMARY CIRCUIT.

- The primary voltage enters the circuit by component 1500 (Prof. version), and 5501 (Cons.version). Beside the function of main input, this component also functions as a mains filter. The isolation between primary and secondary is only single for the Prof. version. The grounding here functions as a safety grounding. You have to consider this information for the high voltage tests. In the rest of the apparatus the safety is reached by a double or an amplified isolation between primary - and secondary circuit. In the Cons. version there is double isolation.
- The primary fuse 1501 has to secure the apparatus against :
 - Shorts in the primary circuit (transformator and primary tracks)
 - Wrong setting of the voltage selector wich results, without precaution, in a to high voltage in the secondary part.
- The mains switch 1508 is singular
- The voltage selector 1503 accepts a setting in the following voltage range :
100 / 120 / 230 / 240 Volts
- Capacitor C2500 makes together with the coil of the transformator a resonantion circuit, this circuit makes sure that by sudden mains interrupts, cause no to high spikes or high frequencies reach the secondary circuit.
- The mains transformer is universal because of the different connections in the primary coil. This requests a special consideration by the release. On the secondary side is, because of simplicity, only a winding for the DC voltage and a filament winding.

1.1.2 RECTIFIER AND EQUALIZATION.

There is used a transformer 1516 with two secondary windings and a middle connection. The first winding 1516 / 4-5-6 is meant for the rectification voltages, and the second winding 1516 / 1-2-3 is for the display voltages. The rectificated voltages are built up of three different arrangements, which will always be rectified by a double sided rectifier that is built out of discrete components followed by an equalization.

- D6502 and D6503 together with C2505 takes care of the first DC voltage
- D6500 and D6501 together with C2503,C2504 and C2502 for the second DC voltage
- D6523 and D6524 together with C2533 for the third DC voltage.

Because these are taken on the same winding of the transformer, the first and second voltage will be approximaly equal : $\pm 32,5$ Volts, for the third volage this is identical but only negative. The values of the elco's are choosen so that they make sure that by a maximum load and the ripple voltage stays within specificators.

1.1.3 STABILIZATION.

The + 5 V is made out of the second DC voltage with after it a switched stabilizer 7500 (MC34166TV). Because of this principle, it is possible to convert a voltage in the range of 20 - 40 volts to a voltage of +5 V with a constant efficiency. In case of a mains interruption the voltage over the capacitors C2303 and C2304 are allowed to drop until a voltage of approximately 8 volts before the regulation drops out.

The regulation is done by a feedback by the resistors R3510 or R3512. The tolerance of the output voltage is from 4.9 volts until 5.15 volts. By adding the resistor R3511 the output voltage can be increased. To protect the apparatus against overvoltage, there's a thyristor 6511 wich pulls the output of 7500 (MC34167) to ground when the voltage of 6,2 volts is crossed.

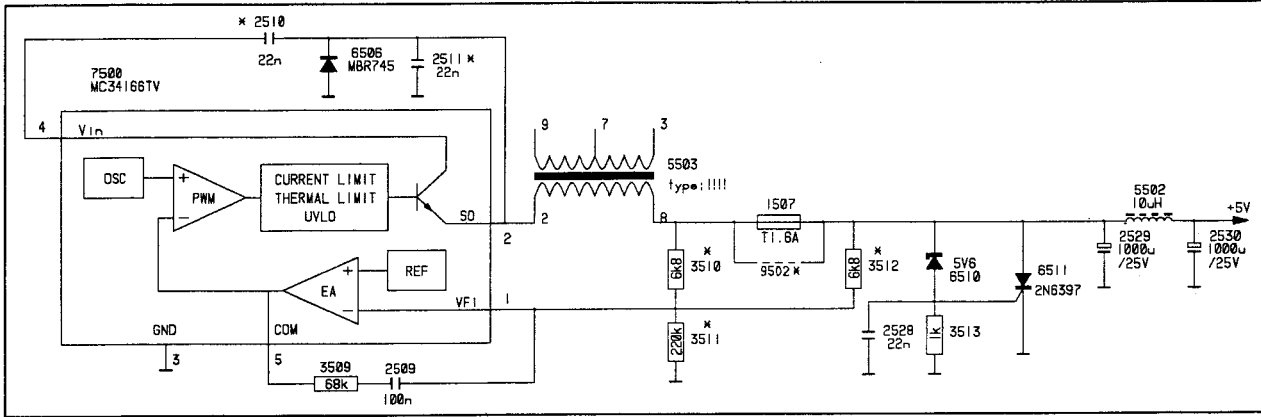

Figuer 1.1.3.1

The voltages for the + 12 V and - 12 V comes from the first DC voltage. The control we use here exists out of a FET 7503 and a coil 5500 and some other components. The startup goes as folows :

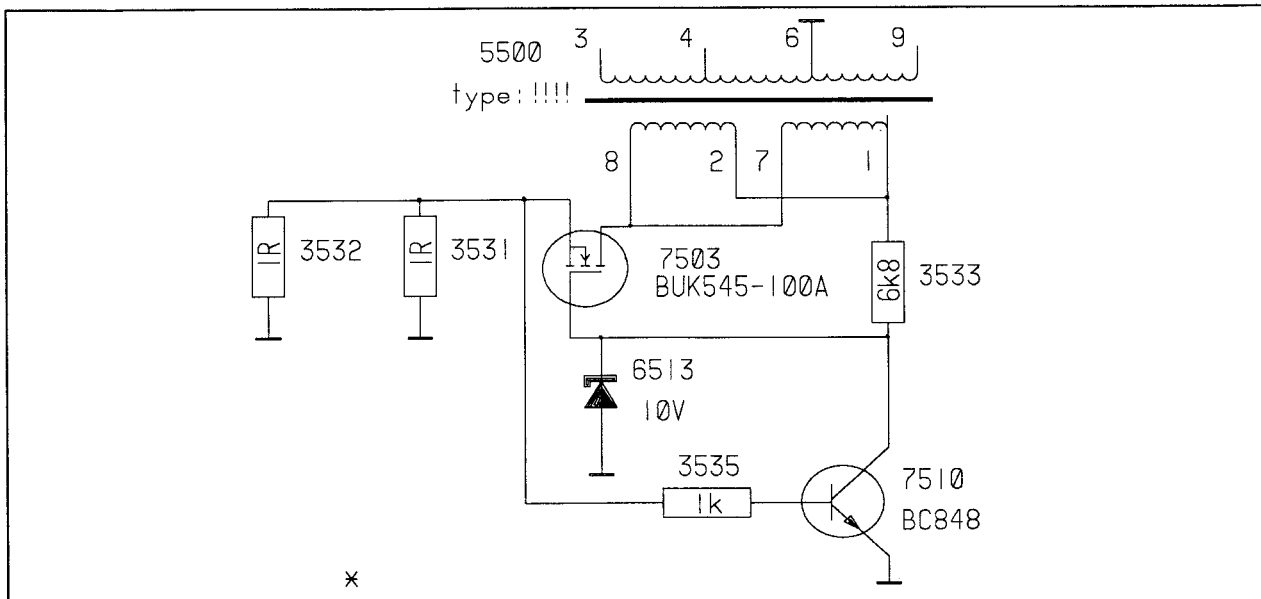

Figuer 1.1.3.2

The FET 7503 goes in conduction because of resistor R3533

The FET 7503 goes out of conduction by a current of $R \cdot I_{max} = 0.6 \text{ V} \implies I_{max} = 0.6 \text{ V} / R_{3532} \text{ and } R_{3531}$.

After startup there is voltage regulation. The FET 7503 goes in conduction because of R3533, and out of conduction depending on the output voltage and these is $= -15 \text{ Volts}$. $I \cdot R \leq 0.6 \text{ Volts}$ and $I \cdot R - 0.6 - 15 - V_{out} = 0$

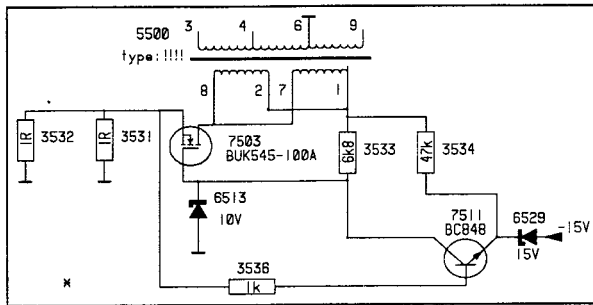

Figure 1.1.3.3

Each time the FET 7503 stops conducting, the voltage at the coil gets so high that the diodes D6509 and D6507 starts conducting. During this time the FET will be kept from conducting by the negative voltage on pin 4 of the transformer 5500 which is connected to the gate of the FET 7503 by resistor R3538 and capacitor C2507.

After that all energy is delivered, pin 4 of the transformer gets positive and the FET goes back into conduction until T7511 is back in conduction and everything starts over again.

D6509 and C2524 take care of a singular rectification with equalization for a voltage of approximately +16 V and is followed by a stabilizer 7505 (stabilizer 7812) which delivers a nice DC voltage of +12 V.

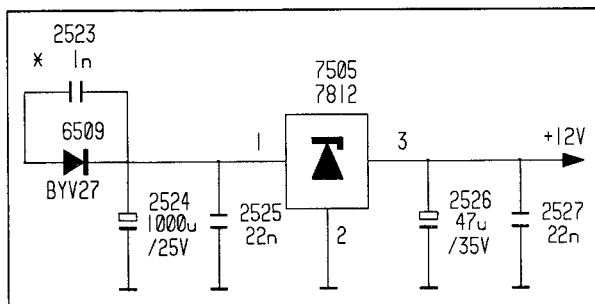

Figure 1.1.3.4

D6507 and C2515 makes a singular rectification with equalization that is approximately -16V, and is followed by a stabilizer 7502 (stabilizer 7912) which delivers a nice DC voltage of -12 V.

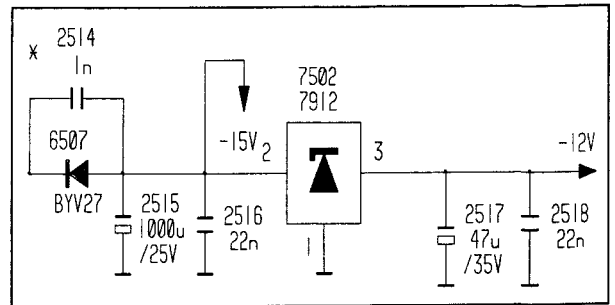

Figure 1.1.3.5

The third DC voltage is for making the VFTD voltage of -24 Volts

After a double side rectification followed by an equalization this negative voltage goes to a stabilizer 7507 (stabilizer 7915) which is set by a zener diode D6514 of 9.1Volts. The total output voltage is $= (-15 \text{ Volts}) + (-9.1 \text{ Volts}) = -24.1 \text{ volts}$. On this output there is also a zener D6515 and R3528 set on 8 volts higher than the output voltage of the VFTD. This is $-24.1 \text{ V} + 8 \text{ V} = -16.1 \text{ Volts}$ to give a DC setting to the display.

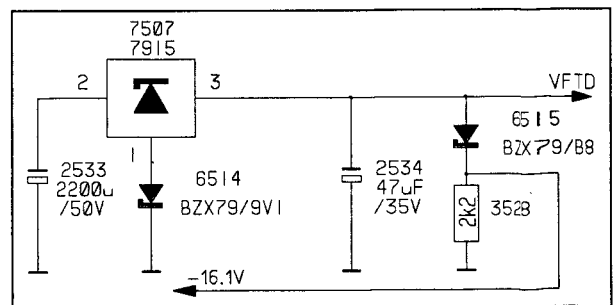

Figure 1.1.3.6

1.1.4 STABILIZATION OF DISPLAY VOLTAGE

There's a DC voltage of -16.1 Volts, on the middle connection of the transformer 1516 / 3 (VFTD voltage) with on that DC voltage an AC voltage added. When the input voltage is to low, there will be no limiting by the transistors T7508 and T7509. (the sinus wave is fed through)

By overvoltage there will be a stabilization by cutting of the tops of the sine wave, depending on which side. This alternation will define which transistor will conduct T7508 or T7509. The top - top value between VFIL1 and VFIL2 is limited until ± 6 Volts. (see figure) This setting is done by the zener diodes D6520 and D6522.

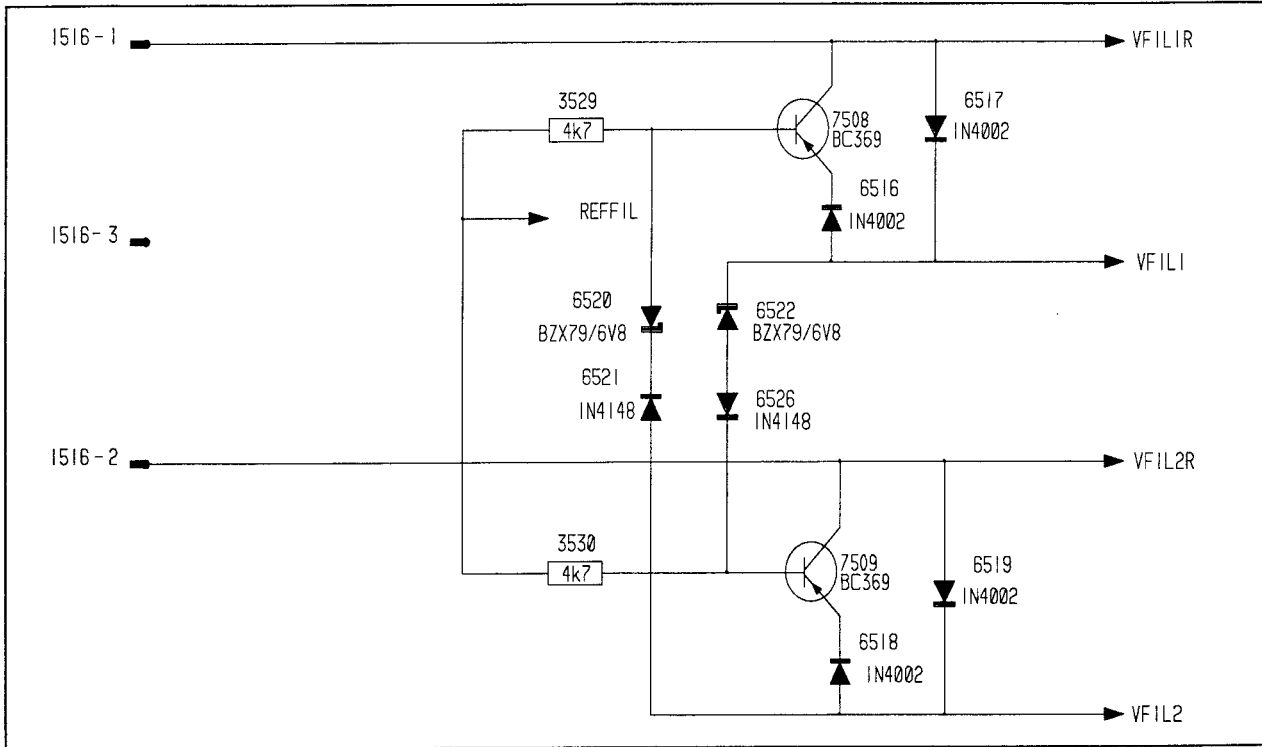

Figure 1.1.4.1

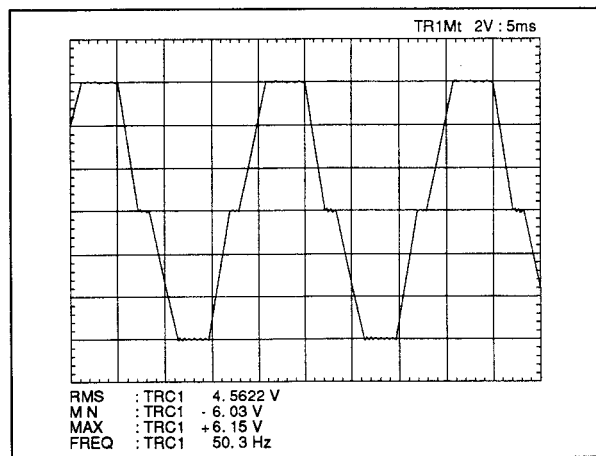

Figure 1.1.4.2

2. MEASUREMENT PROCEDURE

2.1 POWER CONVERSION

2.1.1 CONTROL OF THE STABILIZATION

Connect an AC voltage to point 4,5 and 6 of the transformer T1516 of 27.5 V AC (rms)

Connect an AC voltage to point 1,2 and 3 of the transformer T1516 of 3 V AC (rms)

The load on the output of the +5 V is minimum 1,3 A and maximum 2,2 A

The load on the output of the +12 V is minimum 230 mA and maximum 450 mA

The load on the output of the -12 V is minimum 100 mA and maximum 300 mA

The load on the output of the -VFTD is minimum 0 A and maximum 60 mA

The load on the output of the VFIL1 and VFIL2 is minimum 0 A and maximum 250 mA

The load on the output of the VFIL1R and VFIL2R is minimum 0 A and maximum 250 mA

			<u>MIN</u>	<u>TYP</u>	<u>MAX</u>
Measure on the output the + 5 Volts	(DC)	limit values are	+5.0	+5	+5.3
Measure on the output the + 12 Volts	(DC)	limit values are	+11.4	+12	+12.6
Measure on the output the - 12 Volts	(DC)	limit values are	-11.4	-12	-12.6
Measure on the output the -VFTD	(DC)	limit values are	-22.1	-24.1	-26.1

			<u>MIN</u>	<u>TYP</u>	<u>MAX</u>
Measure on the output between VFIL1 and VFIL2 (AC)		limits are:	3.69	4.1	4.51
Measure on the output the VFIL (AC)	see figure				

MINIMUM LOAD

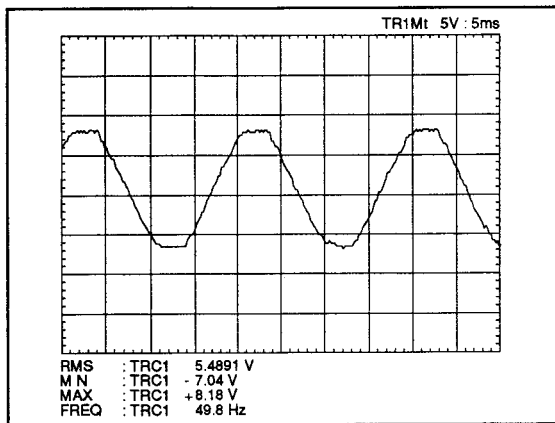

MAXIMUM LOAD

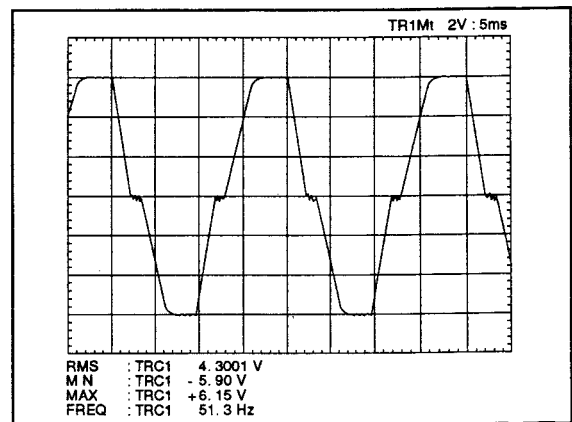

			<u>MIN</u>	<u>TYP</u>	<u>MAX</u>
Measure on the output between VFIL1R and VFIL2R (AC)		limits are:	5.0	5.5	6.0

Measure on the output the VFIL_R (AC) see figure

MINIMUM LOAD

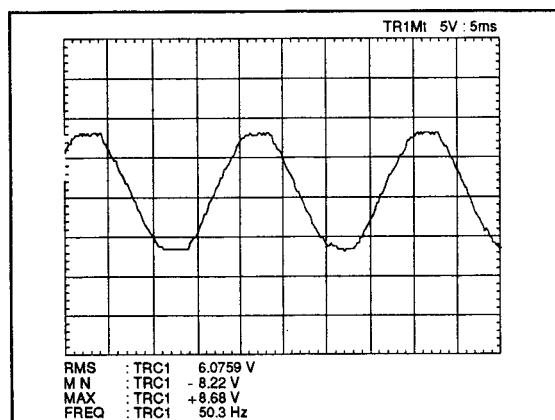

MAXIMUM LOAD

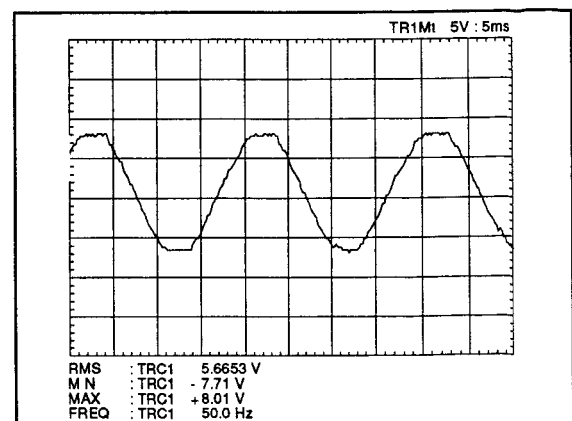

Connect a DC voltage of +25V to pin 4 of IC7500 (MC34167)

The load on the +5Volts is 1 Amp.

Connect pin 5 of IC7500 (MC34167) to ground.

Measure the output if the +5 Volts drops to 0.

In case not, there's a big chance that pin 5 of IC7500 (MC34167) makes a bad contact.

2.1.2 CONTROLE OF THE OVERVOLTAGE PROTECTION.

Discharge the capacitors on the input pin 4 of IC 7500 (MC34167) : C2502, C2503 and C2504.

Connect a voltage of 10 Volts via a series resistor of 27 ohm minimum 5 Watts to pin 2 of thyristor T6511 or to C2529 or C2530.

Measure if the voltage on C2530 is less than 1 V after 2 seconds. In case the overvoltage protection is not working, the voltage would have been higher than 5 Volts after 2 seconds.

2.2 MAINS AND VOLTAGE PROTECTION

2.2.1 CONTROL OF THE POFF SIGNAL.

Connect a DC voltage of +25 V to pin 6 of IC7501 (LM339)

The load on the +5 V is 0 Amp.

Measure if the voltage of the POFF signal is +5 V

Connect a DC voltage of +25 Volts to pin 6 of IC7501 (LM339)

The load on the +5 V is 0 Amp.

Short the junction of R3501 and R3502 to ground.

Measure if the voltage of the POFF signal is 0 V after 20 msec.

2.2.2 CONTROL OF THE RESET SIGNAL.

Connect a DC voltage of 4.3 Volts to pin 2 and 4 of IC7500 (MC34167)

Measure if the reset signal is low (< 0.4 V)

Connect a DC voltage of 4.7 Volts to pin 2 and 4 of IC7500 (MC34167)

Measure if the RESET signal stays low for at least 2 ms and after maximum 5 ms goes high after connecting the external DC voltage.

1.9 ELECTRICAL PARTS LIST

(VERS.:VERSION, U:U.S.A., F:JAPAN, K:FAR EAST, **:EUROPE)

POS. NO	VERS. COLOR	PART NO.	DESCRIPTION	POS. NO	VERS. COLOR	PART NO.	DESCRIPTION
			MONO BOARD (AUDIO PANEL)	2031		4822 124 41527	47uF 25V
			MISCELLANEOUS	2032		4822 122 33496	100nF 10% X7R 63V
1100		4822 265 10311	DIGITAL IN/OUT CONN.	2033		4822 122 33496	100nF 10% X7R 63V
1200		4822 265 10482	YKC21-3071 (CDR615 ONLY)	2034		4822 124 41527	47uF 25V
1380		4822 255 40921	32-DIP-S-LO	2035		4822 122 33496	100nF 10% X7R 63V
1401		4822 242 10236	RESONATOR 16 MHz	2036		4822 124 41527	47uF 25V
1581		4822 267 70347	CON 50P F (CDR620 ONLY)	2037		4822 122 33496	100nF 10% X7R 63V
1582		4822 267 70347	CON 50P F (CDR620 ONLY)	2038		4822 124 41527	47uF 25V
1584		4822 276 13286	SWITCH (CDR620 ONLY)	2100		4822 122 33496	100nF 10% X7R 63V
▲ 4002		4822 051 20008	OR (0805) (CDR620 ONLY)	2101		4822 124 41527	47uF 25V
▲ 4003		4822 051 20008	OR (0805) (CDR620 ONLY)	2102		4822 124 41527	47uF 25V
▲ 4350		4822 051 20008	OR (0805)	2103		4822 122 33496	100nF 10% X7R 63V
5100		4822 242 10228	CRYSTAL 33.8688 MHZ	2104		4822 124 41527	47uF 25V
5210		4822 157 53139	4.7UH	2105		4822 122 33496	100nF 10% X7R 63V
5211		4822 157 63315	COIL	2106		5322 122 32531	100pF 5% NP 50V
5212		4822 157 63315	COIL	2107		4822 126 10326	180pF 5% NP 63V
5320		4822 157 71206	BLM21A10PT	2108		4822 126 10326	180pF 5% NP 63V
▲ 5321		4822 051 20008	OR (0805)	▲ 2109		4822 122 33342	33nF 10% X7R 63V
▲ 5323				2110		4822 122 33325	470nF 16V
5340		4822 157 70601	TRANSFORMER	2111		4822 124 41527	47uF 25V
5410		4822 146 10345	PULSE TRANSFORMER (CDR620 ONLY)	▲ 2112		4822 122 33177	10nF 20% X7R 50V
5411		4822 146 10345	PULSE TRANSFORMER (CDR620 ONLY)	▲ 2113		4822 122 33177	10nF 20% X7R 50V
			CAPACITORS	2114		4822 122 33496	100nF 10% X7R 63V
2000		4822 122 33926	12pF 50V	2115		4822 122 33496	100nF 10% X7R 63V
2001		5322 122 32452	47pF 5% NP 63V	▲ 2149		4822 122 33342	33nF 10% X7R 63V
2002		5322 122 32531	100pF 5% NP 50V	2151		4822 122 33496	100nF 10% X7R 63V
2003		5322 122 32531	100pF 5% NP 50V	▲ 2152		5322 122 32654	22nF 10% X7R 63V
2004		4822 121 51053	2nF 1% 250V	2153		4822 122 33064	330nF 80% Y5V 25V
2005		5322 122 32452	47pF 5% NP 63V	▲ 2154		5322 122 34123	1nF 10% X7R 50V
2006		5322 122 32531	100pF 5% NP 50V	2156		4822 124 41527	47uF 25V
2007		5322 122 32531	100pF 5% NP 50V	2157		4822 122 33496	100nF 10% X7R 63V
2008		4822 122 33926	12pF 50V	2158		4822 122 33496	100nF 10% X7R 63V
2009		5322 122 32452	47pF 5% NP 63V	2200		4822 124 41527	47uF 25V
2010		5322 122 32531	100pF 5% NP 50V	2201		4822 122 33496	100nF 10% X7R 63V
2011		5322 122 32531	100pF 5% NP 50V	2210		4822 124 41527	47uF 25V
2012		4822 121 51053	2nF 1% 250V	2211			
2013		5322 122 32452	47pF 5% NP 63V	i		4822 122 33496	100nF 10% X7R 63V
2014		5322 122 32531	100pF 5% NP 50V	2213			
2015		5322 122 32531	100pF 5% NP 50V	2214		4822 124 41527	47uF 25V
▲ 2016		4822 124 41579	10uF 20% 50V	2215		4822 122 33496	100nF 10% X7R 63V
2017		4822 124 41527	47uF 25V	▲ 2216		4822 124 41579	10uF 20% 50V
2018		4822 124 41527	47uF 25V	2217		4822 122 33496	100nF 10% X7R 63V
2019		4822 122 33496	100nF 10% X7R 63V	2218		4822 124 41527	47uF 25V
2020		4822 122 33496	100nF 10% X7R 63V	2219		4822 122 33496	100nF 10% X7R 63V
2021		5322 122 32452	47pF 5% NP 63V	▲ 2220		4822 124 41579	10uF 20% 50V
▲ 2022		4822 124 41579	10uF 20% 50V	2221		4822 122 33496	100nF 10% X7R 63V
2023		4822 122 33496	100nF 10% X7R 63V	2222		5322 122 32658	22pF 5% 50V
2024		4822 122 33496	100nF 10% X7R 63V	2223		5322 122 32268	470pF 10% 50V
2025		4822 124 41527	47uF 25V	2224		5322 122 32658	22pF 5% 50V
2026		4822 124 41527	47uF 25V	2225		5322 122 32268	470pF 10% 50V
2027		4822 122 33496	100nF 10% X7R 63V	2226		5322 122 32658	22pF 5% 50V
2028		4822 124 41527	47uF 25V	2227		5322 122 32268	470pF 10% 50V
2029		4822 122 33496	100nF 10% X7R 63V	2228		5322 122 32658	22pF 5% 50V
2030		4822 122 33496	100nF 10% X7R 63V	2229		5322 122 32268	470pF 10% 50V
				2230		4822 122 33496	100nF 10% X7R 63V

(VERS. :VERSION, U:U.S.A., F:JAPAN, K:FAR EAST, **:EUROPE)

POS. NO	VERS. COLOR	PART NO.	DESCRIPTION	POS. NO	VERS. COLOR	PART NO.	DESCRIPTION
▲ 2231		4822 124 41579	10uF 20% 50V	2390		5322 122 32452	47pF 5% NP 63V
2232		4822 122 33496	100nF 10% X7R 63V	2391		4822 122 33496	100nF 10% X7R 63V
2233		4822 124 41527	47uF 25V	2393		4822 122 33496	100nF 10% X7R 63V
2234		4822 122 33496	100nF 10% X7R 63V	2394		4822 122 33496	100nF 10% X7R 63V
▲ 2235		4822 124 41579	10uF 20% 50V	2395			
						4822 124 41527	47uF 25V
2236		4822 124 41527	47uF 25V	2398			
2237		4822 122 33496	100nF 10% X7R 63V				
2238				2399		4822 122 33496	100nF 10% X7R 63V
		4822 126 10326	180pF 5% NP 63V	2400		4822 122 33496	100nF 10% X7R 63V
2241				2408		5322 122 32531	100pF 5% NP 50V (CDR620 ONLY)
				2409		5322 122 32531	100pF 5% NP 50V (CDR620 ONLY)
2242		4822 122 33496	100nF 10% X7R 63V	2410		4822 122 33496	100nF 10% X7R 63V (CDR620 ONLY)
2243		4822 124 41528	100uF 25V				
2244		4822 122 33496	100nF 10% X7R 63V	2411		4822 122 33496	100nF 10% X7R 63V (CDR620 ONLY)
2245		4822 124 41528	100uF 25V	▲ 2412		5322 122 34123	1nF 10% X7R 50V (CDR620 ONLY)
2246		4822 122 31746	1000pF 2% NP 63V	2413		5322 122 32531	100pF 5% NP 50V (CDR620 ONLY)
				2414			
2247		4822 122 31746	1000pF 2% NP 63V			4822 122 33496	100nF 10% X7R 63V (CDR620 ONLY)
2248		5322 122 32531	100pF 5% NP 50V	2416			
2249		5322 122 32531	100pF 5% NP 50V				
2250		4822 122 33496	100nF 10% X7R 63V	2417		5322 122 32531	100pF 5% NP 50V (CDR620 ONLY)
2251		4822 124 41528	100uF 25V	2418			
						4822 122 33496	100nF 10% X7R 63V (CDR620 ONLY)
2252		4822 122 33496	100nF 10% X7R 63V	2420			
2253		4822 124 41528	100uF 25V	2421		4822 122 32139	12pF 2% NP 63V (CDR620 ONLY)
2254		4822 124 22339	100uF 16V				
2255		4822 124 22339	100uF 16V	2422			
2300		4822 124 41527	47uF 25V			4822 122 33496	100nF 10% X7R 63V (CDR620 ONLY)
				2424			
2301		4822 122 33496	100nF 10% X7R 63V	2425			
2302		4822 124 41527	47uF 25V			4822 124 41528	100uF 25V (CDR620 ONLY)
2303		4822 122 33496	100nF 10% X7R 63V	2427			
2304		5322 122 32661	56pF 5% 50V				
2310		5322 122 32531	100pF 5% NP 50V	2428		4822 122 33496	100nF 10% X7R 63V (CDR620 ONLY)
				2430			
2311		4822 122 33496	100nF 10% X7R 63V			4822 124 22339	100uF 16V
2312		4822 124 41527	47uF 25V	2433			
2313		4822 122 33496	100nF 10% X7R 63V	2434		5322 122 32531	100pF 5% NP 50V
2314		4822 122 33496	100nF 10% X7R 63V				
2315		4822 124 41527	47uF 25V	2435		4822 122 33496	100nF 10% X7R 63V
				2436		4822 122 32139	12pF 2% NP 63V
2320				2437		4822 122 33496	100nF 10% X7R 63V
		5322 122 32658	22pF 5% 50V	2438		4822 122 33496	100nF 10% X7R 63V
2323				2439			
2324		5322 122 32452	47pF 5% NP 63V			4822 122 32139	12pF 2% NP 63V
2325		5322 122 33575	220pF 5% NP 50V (CDR615 ONLY)	2441			
2326		5322 122 33575	220pF 5% NP 50V (CDR615 ONLY)	2442		5322 122 32531	100pF 5% NP 50V
2327		5322 122 32452	47pF 5% NP 63V	2443		4822 122 33496	100nF 10% X7R 63V
2340				2444		4822 122 33496	100nF 10% X7R 63V
		4822 122 32542	47nF 10% X7R 63V	2445		5322 122 32531	100pF 5% NP 50V
2342				2446		4822 122 33496	100nF 10% X7R 63V
▲ 2343		4822 124 41579	10uF 20% 50V	2447		4822 122 32139	12pF 2% NP 63V
2344		5322 122 32659	33pF 5% 50V	2448		4822 122 33496	100nF 10% X7R 63V
2345		4822 122 33496	100nF 10% X7R 63V	2449		4822 122 33496	100nF 10% X7R 63V
▲ 2371		5322 122 32654	22nF 10% X7R 63V (CDR615 ONLY)	2450			
2379						4822 122 32139	12pF 2% NP 63V
		4822 122 33496	100nF 10% X7R 63V	2452			
2384							
				2453		5322 122 32531	100pF 5% NP 50V
▲ 2385		5322 122 32654	22nF 10% X7R 63V	2454		4822 122 33496	100nF 10% X7R 63V
2386				2455		4822 122 33496	100nF 10% X7R 63V
		4822 122 33496	100nF 10% X7R 63V	2456		5322 122 32531	100pF 5% NP 50V
2388				2459		4822 122 33496	100nF 10% X7R 63V
2389		5322 122 32452	47pF 5% NP 63V				

(VERS.:VERSION, U:U.S.A., F:JAPAN, K:FAR EAST, **:EUROPE)

POS. NO	VERS. COLOR	PART NO.	DESCRIPTION	POS. NO	VERS. COLOR	PART NO.	DESCRIPTION
2460		4822 122 33496	100nF 10% X7R 63V	▲ 3012		4822 051 20109	10R 5% 0.1W
2461		5322 122 32531	100pF 5% NP 50V	3013		4822 117 10358	5K6 1% 0.1W
2462				3014		4822 117 10358	5K6 1% 0.1W
		4822 124 41528	100uF 25V	3015		4822 117 10353	150R 1% 0.1W
2469				3016		4822 117 11503	220R 1% 0.1W
2472		4822 124 41527	47uF 25V	▲ 3017			
2473		4822 124 41527	47uF 25V			4822 117 11152	4R7 5%
2480				▲ 3021			
		4822 124 41528	100uF 25V (CDR620 ONLY)	3022		4822 117 11503	220R 1% 0.1W
2491				3023		4822 051 20471	470R 5% 0.1W
2492		4822 122 33496	100nF 10% X7R 63V (CDR620 ONLY)	3024		4822 051 20471	470R 5% 0.1W
2493		4822 122 33496	100nF 10% X7R 63V (CDR620 ONLY)	▲ 3100			
2494		4822 122 32139	12pF 2% NP 63V (CDR620 ONLY)			4822 117 11152	4R7 5%
2495		5322 122 32531	100pF 5% NP 50V (CDR620 ONLY)	▲ 3102			
2496		4822 122 32139	12pF 2% NP 63V (CDR620 ONLY)	3103		4822 051 20473	47K 5% 0.1W
2497		4822 122 32139	12pF 2% NP 63V (CDR620 ONLY)	3104		4822 117 10833	10K 1% 0.1W
2498		5322 122 32531	100pF 5% NP 50V (CDR620 ONLY)	3105		4822 117 11139	1K5 1% 0.1W
2499		4822 122 33496	100nF 10% X7R 63V (CDR620 ONLY)	3106		4822 051 20274	270K 5% 0.1W
2500		4822 122 33496	100nF 10% X7R 63V (CDR620 ONLY)	3107		4822 117 10833	10K 1% 0.1W
2501		5322 122 32531	100pF 5% NP 50V (CDR620 ONLY)	3108		4822 051 20273	27K 5% 0.1W
2502		4822 122 33496	100nF 10% X7R 63V (CDR620 ONLY)	3109		4822 117 11507	6K8 1% 0.1W
2503		4822 122 33496	100nF 10% X7R 63V (CDR620 ONLY)	▲ 3110		4822 051 20008	0R (0805)
2504		5322 122 32531	100pF 5% NP 50V (CDR620 ONLY)	3111		4822 051 20105	1M 5% 0.1W
2505		5322 122 32531	100pF 5% NP 50V (CDR620 ONLY)	3112		4822 051 20301	300R 5% 0.1W
2506		4822 122 33496	100nF 10% X7R 63V (CDR620 ONLY)	3113		4822 117 12114	6K8 2% 0.1W (CDR615 ONLY)
2507		4822 122 33496	100nF 10% X7R 63V (CDR620 ONLY)	3114		4822 051 20272	2K7 5% 0.1W
2508		4822 122 32139	12pF 2% NP 63V (CDR620 ONLY)	3115		4822 117 11384	2K7 1% 0.1W
2509		5322 122 32531	100pF 5% NP 50V (CDR620 ONLY)	3116		4822 117 11145	4K7 1% 0.1W
2510		4822 122 32139	12pF 2% NP 63V (CDR620 ONLY)	▲ 3118		4822 117 11152	4R7 5%
2511		4822 122 32139	12pF 2% NP 63V (CDR620 ONLY)	▲ 3119		4822 117 11152	4R7 5%
2512		5322 122 32531	100pF 5% NP 50V (CDR620 ONLY)	3120		4822 051 20331	330R 5% 0.1W
2513		4822 122 33496	100nF 10% X7R 63V (CDR620 ONLY)	▲ 3150		4822 117 11152	4R7 5%
2514		4822 122 33496	100nF 10% X7R 63V (CDR620 ONLY)	3153			
2515		5322 122 32531	100pF 5% NP 50V (CDR620 ONLY)			4822 051 20331	330R 5% 0.1W
2516		4822 122 33496	100nF 10% X7R 63V (CDR620 ONLY)	3157			
2517		4822 122 33496	100nF 10% X7R 63V (CDR620 ONLY)	3158		4822 051 20473	47K 5% 0.1W
2518				3159		4822 051 20331	330R 5% 0.1W
		5322 122 32531	100pF 5% NP 50V (CDR620 ONLY)	3160		4822 051 20271	270R 5% 0.1W
2521				▲ 3201		4822 117 11152	4R7 5%
2522				▲ 3210		4822 117 11747	12R 1206 5% FUSE
		4822 124 22339	100uF 16V (CDR620 ONLY)	3211			
2527						4822 051 20101	100R 5% 0.1W
			RESISTORS	3213			
3000				▲ 3214		4822 117 11152	4R7 5%
		4822 117 10358	5K6 1% 0.1W	3215		4822 117 11539	51K 1% 0.1W
3003				3216		4822 117 11539	51K 1% 0.1W
▲ 3004		4822 051 20109	10R 5% 0.1W	3217		4822 117 10507	24K 1% 0.1W
3005		4822 117 10358	5K6 1% 0.1W	3218		4822 117 11539	51K 1% 0.1W
3006		4822 117 10358	5K6 1% 0.1W	3219		4822 117 11539	51K 1% 0.1W
3007		4822 117 10353	150R 1% 0.1W	▲ 3220		4822 117 11152	4R7 5%
3008				3221		4822 051 20101	100R 5% 0.1W
		4822 117 10358	5K6 1% 0.1W	3222			
3011						4822 117 10833	10K 1% 0.1W
				3227			
				▲ 3228		4822 117 11747	12R 1206 5% FUSE

(VERS.:VERSION, U:U.S.A., F:JAPAN, K:FAR EAST, **:EUROPE)

POS. NO	VERS. COLOR	PART NO.	DESCRIPTION
3229		4822 117 10833	10K 1% 0.1W
▲ 3230		4822 117 11747	12R 1206 5% FUSE
3231		4822 117 10833	10K 1% 0.1W
3232		4822 117 10358	5K6 1% 0.1W
3233		4822 117 10358	5K6 1% 0.1W
3234		4822 117 10362	7K5 1% 0.1W
3235		4822 117 10362	7K5 1% 0.1W
3236		4822 117 10833	10K 1% 0.1W
3237		4822 117 10833	10K 1% 0.1W
3238		4822 117 10358	5K6 1% 0.1W
3239		4822 117 10358	5K6 1% 0.1W
▲ 3240		4822 117 11747	12R 1206 5% FUSE
▲ 3241		4822 117 11747	12R 1206 5% FUSE
3242		4822 117 10833	10K 1% 0.1W
3243		4822 117 10833	10K 1% 0.1W
3260		4822 117 10833	10K 1% 0.1W (CDR615 ONLY)
3261		4822 051 20473	47K 5% 0.1W (CDR615 ONLY)
3262		4822 117 10833	10K 1% 0.1W (CDR615 ONLY)
3263		4822 051 20473	47K 5% 0.1W (CDR615 ONLY)
▲ 3264		4822 051 20472	4K7 5% 0.1W (CDR615 ONLY)
▲ 3265		4822 051 20472	4K7 5% 0.1W (CDR615 ONLY)
3266		4822 051 20224	220K 5% 0.1W (CDR615 ONLY)
3267		4822 051 20224	220K 5% 0.1W (CDR615 ONLY)
3268		4822 051 20474	470K 5% 0.1W (CDR615 ONLY)
3269		4822 051 20474	470K 5% 0.1W (CDR615 ONLY)
3280		4822 051 20473	47K 5% 0.1W
3281		4822 051 20104	100K 5% 0.1W
3282		4822 051 20473	47K 5% 0.1W
3283		4822 117 10833	10K 1% 0.1W
3284		4822 051 20473	47K 5% 0.1W
3285		4822 051 20104	100K 5% 0.1W
3286		4822 051 20122	1K2 5% 0.1W (CDR615 ONLY)
3287		4822 117 11449	2K2 1% 0.1W (CDR615 ONLY)
3288		4822 051 20122	1K2 5% 0.1W (CDR615 ONLY)
3289		4822 117 11449	2K2 1% 0.1W (CDR615 ONLY)
3290			
		4822 117 11373	100R 1% RC12H 0805 (CDR615 ONLY)
3293			
3294		4822 117 10833	10K 1% 0.1W
3295		4822 051 10102	1K 2% 0.25W
▲ 3300		4822 117 11152	4R7 5%
▲ 3301		4822 117 11152	4R7 5%
3302		4822 051 20101	100R 5% 0.1W
3304			
		4822 051 20101	100R 5% 0.1W
3306			
3310		4822 117 11927	75R 1% 0.1W
3311		4822 051 10102	1K 2% 0.25W
▲ 3312		4822 051 20332	3K3 5% 0.1W
▲ 3313		4822 117 11152	4R7 5%
▲ 3314		4822 117 11152	4R7 5%
3330			
		4822 117 10833	10K 1% 0.1W
3334			
3340		4822 051 20569	56R 5% 0.1W
3341		4822 117 11503	220R 1% 0.1W

POS. NO	VERS. COLOR	PART NO.	DESCRIPTION
3342		4822 117 11503	220R 1% 0.1W
▲ 3343		4822 117 11152	4R7 5%
3370		4822 117 10833	10K 1% 0.1W (CDR615 ONLY)
3371		4822 051 20473	47K 5% 0.1W (CDR615 ONLY)
3375		4822 051 20223	22K 5% 0.1W
3376		4822 051 20223	22K 5% 0.1W
3378		4822 051 20223	22K 5% 0.1W
3379		4822 051 20223	22K 5% 0.1W
▲ 3380			
		4822 117 11152	4R7 5%
▲ 3384			
3385			
		4822 117 10833	10K 1% 0.1W
3387			
3388		4822 051 20105	1M 5% 0.1W
3389			
		4822 117 10833	10K 1% 0.1W
3398			
▲ 3404		4822 117 11152	4R7 5%
▲ 3410			
		4822 117 11152	4R7 5% (CDR620 ONLY)
▲ 3413			
3414		4822 051 20333	33K 5% 0.1W (CDR620 ONLY)
3415			
3416		4822 051 20682	6K8 5% 0.1W (CDR620 ONLY)
3417		4822 051 20224	220K 5% 0.1W (CDR620 ONLY)
3418		4822 051 20394	390K 5% 0.1W (CDR620 ONLY)
3419		4822 051 20222	2K2 5% 0.1W (CDR620 ONLY)
3420		4822 051 20332	3K3 5% 0.1W (CDR620 ONLY)
3420		4822 051 10102	1K 2% 0.25W (CDR620 ONLY)
▲ 3421		4822 052 10569	56R 5% 0.33W (CDR620 ONLY)
3422		4822 051 20103	10K 5% 0.1W (CDR620 ONLY)
3423		4822 051 20471	470R 5% 0.1W (CDR620 ONLY)
3424		4822 117 10838	110K 1% 0.1W (CDR620 ONLY)
▲ 3425		4822 052 10569	56R 5% 0.33W (CDR620 ONLY)
3426		4822 051 20473	47K 5% 0.1W (CDR620 ONLY)
▲ 3427		4822 117 11152	4R7 5% (CDR620 ONLY)
3430		4822 117 10837	100K 1% 0.1W
3431		4822 117 10837	100K 1% 0.1W
3432		4822 117 10352	33K 1% 0.2W
3433		4822 117 10833	10K 1% 0.1W
3434		4822 117 11536	3K3 1% 0.1W
3435		4822 117 11449	2K2 1% 0.1W
3436		4822 117 10352	33K 1% 0.2W
3437		4822 117 10833	10K 1% 0.1W
3438		4822 051 20332	3K3 5% 0.1W
3439		4822 117 10833	10K 1% 0.1W
3440		4822 117 10362	7K5 1% 0.1W
3441		4822 117 10833	10K 1% 0.1W
3442		4822 117 10362	7K5 1% 0.1W
3443		4822 117 10833	10K 1% 0.1W
3444		4822 051 20332	3K3 5% 0.1W
3445		4822 117 11449	2K2 1% 0.1W
3446		4822 117 10833	10K 1% 0.1W

(VERS.:VERSION, U:U.S.A., F:JAPAN, K:FAR EAST, **:EUROPE)

POS. NO	VERS. COLOR	PART NO.	DESCRIPTION	POS. NO	VERS. COLOR	PART NO.	DESCRIPTION
3447		4822 051 20332	3K3 5% 0.1W	3521		4822 051 20474	470K 5% 0.1W (CDR620 ONLY)
3448		4822 117 10833	10K 1% 0.1W	3522		4822 052 10249	24R 5% 0.33W (CDR620 ONLY)
3449		4822 117 10362	7K5 1% 0.1W	3523		4822 117 10833	10K 1% 0.1W (CDR620 ONLY)
3450		4822 117 10833	10K 1% 0.1W	▲ 3524			
3451		4822 117 10362	7K5 1% 0.1W			4822 117 11747	12R 1206 5% FUSE (CDR620 ONLY)
				▲ 3535			
3454		4822 051 20471	470R 5% 0.1W				SEMICONDUCTORS
3455		4822 051 20471	470R 5% 0.1W	▲ 6000		5322 130 33763	BZX84-C7V5
3456		4822 117 11141	1K8 1% 0.1W	▲ 6001		5322 130 33763	BZX84-C7V5
3457		4822 117 11141	1K8 1% 0.1W	6100		4822 130 31129	BB212
3458		4822 117 10837	100K 1% 0.1W	6101		4822 130 33996	BZX84-C9V1
				6280		4822 130 80622	BAT54
3459		4822 117 10837	100K 1% 0.1W				
3460		4822 117 10352	33K 1% 0.2W	6400		4822 130 80622	BAT54 (CDR620 ONLY)
3461		4822 117 10352	33K 1% 0.2W	6432		4822 130 80125	BZX84-C5V6
3462		4822 117 11141	1K8 1% 0.1W	6433		4822 130 80125	BZX84-C5V6
3463		4822 117 11141	1K8 1% 0.1W	7000			
▲ 3464						5322 209 91079	OP275GS
		4822 117 11747	12R 1206 5% FUSE	7002			
▲ 3471							
3472		4822 101 11217	2K2 25%	7003		4822 209 12695	ADM0D79
3473		4822 101 11217	2K2 25%	▲ 7004		4822 209 80817	L7805CV
				7005		4822 209 72684	L7905CV
3480		4822 051 20474	470K 5% 0.1W (CDR620 ONLY)	7100		4822 130 61207	BC848 (UAW)
3481				7101		5322 209 61487	LM358N
		4822 052 10249	24R 5% 0.33W (CDR620 ONLY)				
3483				7102		4822 130 61207	BC848 (UAW)
3484		4822 051 20474	470K 5% 0.1W (CDR620 ONLY)	7103		4822 209 12696	TDA1373H/N2
				7104		5322 209 73179	74HCT74D
3485		4822 052 10249	24R 5% 0.33W (CDR620 ONLY)	7105		4822 209 33465	74HCT4046AD
3486		4822 117 10357	4K3 1% 0.2W (CDR620 ONLY)	7150		4822 209 33395	TDA1315H/N2
3487		4822 117 10357	4K3 1% 0.2W (CDR620 ONLY)				
3488		4822 051 20474	470K 5% 0.1W (CDR620 ONLY)	7200		4822 209 12697	SM5841AS
3489		4822 117 10362	7K5 1% 0.1W (CDR620 ONLY)	7210		4822 209 31356	SAA7350AGP
				7211		5322 209 91079	OP275GS
3490		4822 117 11384	2K7 1% 0.1W (CDR620 ONLY)	7212		5322 209 91079	OP275GS
3491				7260		4822 130 61207	BC848 (UAW) (CDR615 ONLY)
		4822 117 10358	5K6 1% 0.1W (CDR620 ONLY)				
3496				7261		4822 130 61207	BC848 (UAW) (CDR615 ONLY)
3497		4822 117 11384	2K7 1% 0.1W (CDR620 ONLY)	7262		5322 130 41983	BC858 (UAW) (CDR615 ONLY)
				7263		5322 130 41983	BC858 (UAW) (CDR615 ONLY)
3498		4822 117 11154	1K 1% 0.1W (CDR620 ONLY)	7264		4822 130 42633	BSR56 (CDR615 ONLY)
3499		4822 117 11154	1K 1% 0.1W (CDR620 ONLY)	7265		4822 130 42633	BSR56 (CDR615 ONLY)
3500		4822 052 10249	24R 5% 0.33W (CDR620 ONLY)				
3501		4822 117 10833	10K 1% 0.1W (CDR620 ONLY)	7280		4822 130 61207	BC848 (UAW)
3502		4822 051 20474	470K 5% 0.1W (CDR620 ONLY)	7281		4822 130 61207	BC848 (UAW)
				7282		5322 130 42012	BC858 (UAW)
3503		4822 052 10249	24R 5% 0.33W (CDR620 ONLY)	7283			
3504		4822 117 10833	10K 1% 0.1W (CDR620 ONLY)			4822 130 42696	BC818-25 (CDR615 ONLY)
3505		4822 117 10357	4K3 1% 0.2W (CDR620 ONLY)	7286			
3506		4822 117 10357	4K3 1% 0.2W (CDR620 ONLY)				
3507		4822 051 20474	470K 5% 0.1W (CDR620 ONLY)	7300		4822 209 60792	74HC4053D
				7301		4822 209 12698	MC74HC125AD
3508		4822 117 10362	7K5 1% 0.1W (CDR620 ONLY)	7310		5322 209 11517	PC74HCU04T
3509		4822 117 11384	2K7 1% 0.1W (CDR620 ONLY)	7311		4822 209 60792	74HC4053D
3510				7340		5322 209 31284	SN74ALS08D (CDR620 ONL)
		4822 117 10358	5K6 1% 0.1W (CDR620 ONLY)				
3515				7370		4822 130 61207	BC848 (UAW) (CDR615 ONL)
				7380		4822 900 10974	EPROM (CDR620)
3516		4822 117 11384	2K7 1% 0.1W (CDR620 ONLY)	7380		4822 900 10972	EPROM (CDR615)
3517		4822 117 11154	1K 1% 0.1W (CDR620 ONLY)	7381		4822 209 30724	MC74HC374ADW
3518		4822 117 11154	1K 1% 0.1W (CDR620 ONLY)	7382		4822 209 12709	MC68HC11K4-
3519		4822 052 10249	24R 5% 0.33W (CDR620 ONLY)				
3520		4822 117 10833	10K 1% 0.1W (CDR620 ONLY)				

(VERS.:VERSION, U:U.S.A., F:JAPAN, K:FAR EAST, **:EUROPE)

POS. NO	VERS. COLOR	PART NO.	DESCRIPTION	POS. NO	VERS. COLOR	PART NO.	DESCRIPTION
7383		5322 209 60299	74HCT00D	▲ 3909		4822 050 24703	47K 1% 0.6W
7384		4822 209 60792	74HC4053D	3910		4822 116 52235	1M 5% 0.5W
7385				▲ 3911		4822 051 20472	4K7 5% 0.1W
		4822 209 31284	MC74HC08AD	3912		4822 050 22203	22K 1% 0.6W
7387				▲ 3913		4822 050 21002	1K 1% 0.6W
7390		5322 209 11596	74HCT08D	3914		4822 051 10102	1K 2% 0.25W
7391		5322 209 60299	74HCT00D	▲ 3915		5322 111 90473	RES.NETWORK
7392		4822 209 12712	KM6264BLG-7	▲ 3916		5322 111 90473	RES.NETWORK
7393		4822 209 30724	MC74HC374ADW	▲ 3917			
7394		4822 209 31284	MC74HC08AD			4822 052 10478	4R7 5% 0.33W
7410		5322 209 11517	PC74HCU04T (CDR620 ONLY)	▲ 3919			
7411		5322 209 60472	SN75157P (CDR620 ONLY)				
7412		5322 209 61482	MC74HC4066D (CDR620 ONLY)	6900		4822 130 10052	GL5ED44
7413		4822 209 12719	CS8402A-CS (CDR620 ONLY)	6902		4822 130 30613	BAW62
7414		4822 209 30721	MC74HC74AD (CDR620 ONLY)	6904			
7430		4822 209 60792	74HC4053D			4822 130 30613	BAW62
7431		4822 209 60792	74HC4053D	6908			
7432							
		4822 209 32002	NJM5532MD	7900		4822 135 00002	BJ379GK DISPLAY
7435				7901		4822 209 31251	TMP47C670P-FTDD007
7480		5322 209 86463	NE5534D (CDR620 ONLY)	7902		4822 209 31623	MSL915
7481		5322 209 86463	NE5534D (CDR620 ONLY)	7903		4822 209 31623	MSL915
7482				7904		4822 130 44121	BC338
		4822 209 32002	NJM5532MD (CDR620 ONLY)	7905		4822 130 44121	BC338
7485							
7486							
		4822 130 42633	BSR56 (CDR620 ONLY)	1651		4822 267 31453	HEAD PHONE JACK
7491				▲ 4000		4822 051 20008	0R (0805)
				▲ 4001		4822 051 20008	0R (0805)
				▲ 4603		4822 051 20008	0R (0805)
1900		4822 242 81002	CST6.00MGW-TF01				
1920				2650		4822 124 41528	100uF 25V
		4822 276 13114	TACT SWITCH	2651		4822 124 41528	100uF 25V
1925				▲ 2652		5322 122 34123	1nF 10% X7R 50V
1927				▲ 2653		5322 122 34123	1nF 10% X7R 50V
		4822 276 13114	TACT SWITCH	▲ 2654		5322 122 32654	22nF 10% X7R 63V
1932							
1935				▲ 2655		5322 122 32654	22nF 10% X7R 63V
		4822 276 13114	TACT SWITCH	▲ 2656		5322 122 34123	1nF 10% X7R 50V
1938							
▲ 4900		4822 051 20008	0R (0805)	3650		4822 051 20104	100K 5% 0.1W
				3651		4822 116 52234	100K 5% 0.5W
				3652		4822 117 11373	100R 1% RC12H 0805
				▲ 3653		4822 051 20121	120R 5% 0.1W
2900				3654		4822 117 11383	12K 1% 0.1W
		5322 124 21643	22uF 20% 40V				
2902				3655		4822 051 20273	27K 5% 0.1W
▲ 2903		5322 126 13187	22nF 100V	3656		4822 117 11373	100R 1% RC12H 0805
▲ 2904		5322 126 13187	22nF 100V	3657		4822 117 11383	12K 1% 0.1W
2905		4822 122 10177	10nF 20% 25V	3658		4822 050 21201	120R 1% 0.6W
2906		4822 122 10177	10nF 20% 25V	3659		4822 051 20273	27K 5% 0.1W
				▲ 3660		4822 117 11747	12R 1206 5% FUSE
▲ 3900		4822 050 23301	330R 1% 0.6W	▲ 3661		4822 117 11747	12R 1206 5% FUSE
▲ 3901		4822 050 23301	330R 1% 0.6W	3662		4822 101 21199	10KX2 20% 0.025W
▲ 3902		4822 050 24703	47K 1% 0.6W				
▲ 3903		4822 050 24703	47K 1% 0.6W				
3904							
		4822 050 22203	22K 1% 0.6W	7650		4822 130 42633	BSR56
3908				7651		4822 130 42633	BSR56
				7652		4822 209 82362	NJM4556AD

(VERS.:VERSION, U:U.S.A., F:JAPAN, K:FAR EAST, **:EUROPE)

POS. NO	VERS. COLOR	PART NO.	DESCRIPTION	POS. NO	VERS. COLOR	PART NO.	DESCRIPTION
			LEVEL BOARD (VOL. PANEL) CAPACITORS				
2600		4822 124 22339	100uF 16V	▲ 2518		5322 122 32654	22nF 10% X7R 63V
2603				▲ 2523		5322 122 34123	1nF 10% X7R 50V
▲ 2604		5322 122 32654	22nF 10% X7R 63V	2524		4822 124 80259	1000uF 20% 25V
▲ 2605		5322 122 32654	22nF 10% X7R 63V	▲ 2525		5322 122 32654	22nF 10% X7R 63V
2606		4822 124 41527	47uF 25V	2526		4822 124 22427	47uF 20% 40V
2607		4822 124 41527	47uF 25V				
			RESISTORS	▲ 2527		5322 122 32654	22nF 10% X7R 63V
3600		4822 117 11437	8K2 1% 0.1W	2529		4822 124 40201	1000uF 20% 16V
3601		4822 117 11188	20K 1% 0.1W	2530		4822 124 40201	1000uF 20% 16V
3602		4822 117 11188	20K 1% 0.1W	2531		4822 122 33496	100nF 10% X7R 63V
3603		4822 117 11437	8K2 1% 0.1W	▲ 2532		5322 122 32654	22nF 10% X7R 63V
3604		4822 117 10833	10K 1% 0.1W				
3605		4822 117 10833	10K 1% 0.1W	2533		4822 124 23172	470uF 20% 50V
▲ 3606		4822 117 11747	12R 1206 5% FUSE	2534		4822 124 22427	47uF 20% 40V
▲ 3607		4822 117 11747	12R 1206 5% FUSE	▲ 2535		4822 126 10454	3.3nF 20% 400V
3608		4822 101 11347	POTM. LOG. 2X20K	▲ 2536		5322 122 32654	22nF 10% X7R 63V
			SEMICONDUCTORS				RESISTORS
7600		5322 209 91079	OP275GS	3501		4822 117 10833	10K 1% 0.1W (CDR615 ONLY)
7601		5322 209 91079	OP275GS	3502		4822 117 10833	10K 1% 0.1W (CDR615 ONLY)
			POWER SUPPLY BOARD MISCELLANEOUS	3503		4822 051 10102	1K 2% 0.25W
▲ 1500		4822 265 20492	FN326-1/02	3504		4822 051 20473	47K 5% 0.1W
▲ 1501		4822 070 31002	FUSE HOLDER	3505		4822 117 10833	10K 1% 0.1W
1503		4822 277 11483	VOLTAGE SELECTOR	3506		4822 117 10833	10K 1% 0.1W
▲ 1504		4822 252 51186	19398E1(2.0A)	3507		4822 051 20104	100K 5% 0.1W
▲ 1508		4822 276 13224	SWITCH	3508		4822 117 10833	10K 1% 0.1W
▲ 1509		4822 252 51186	19398E1(2.0A)	3509		4822 051 20683	68K 5% 0.1W
▲ 4002		4822 051 20008	0R (0805)	3510		4822 051 20682	6K8 5% 0.1W
▲ 4003		4822 051 20008	0R (0805)				
5500		4822 146 10346	DC/DC CONVERTER TRAF	3511		4822 051 20224	220K 5% 0.1W
5502		5322 157 52513	COIL	3514		4822 117 10833	10K 1% 0.1W (CDR615 ONLY)
5503		4822 146 10347	DC/DC CONVERTER TRAF	3515		4822 051 20223	22K 5% 0.1W (CDR615 ONLY)
			CAPACITORS	3516		4822 116 52234	100K 5% 0.5W (CDR615 ONLY)
▲ 2500		4822 121 70479	100nF 10% 250V	3517		4822 051 10102	1K 2% 0.25W (CDR615 ONLY)
▲ 2501		5322 122 32654	22nF 10% X7R 63V				
2502		4822 124 22427	47uF 20% 40V	3518		4822 051 20334	330K 5% 0.1W (CDR615 ONLY)
2503				3519		4822 117 11154	1K 1% 0.1W
2505		4822 124 11474	2200uF 20% 50V	3520		4822 117 11154	1K 1% 0.1W
2506		5322 122 31866	6.8nF 10% X7R 63V	3521		4822 117 10833	10K 1% 0.1W (CDR615 ONLY)
2507		4822 122 33891	3.3nF 10% X7R 63V	3522		4822 051 20474	470K 5% 0.1W (CDR615 ONLY)
2509		4822 122 33496	100nF 10% X7R 63V				
▲ 2511		5322 122 32654	22nF 10% X7R 63V (CDR615 ONLY)	3523		4822 117 10833	10K 1% 0.1W (CDR615 ONLY)
▲ 2512		5322 122 32654	22nF 10% X7R 63V	3524		4822 051 20474	470K 5% 0.1W (CDR615 ONLY)
2513		4822 122 33496	100nF 10% X7R 63V	3525		4822 117 10833	10K 1% 0.1W (CDR615 ONLY)
▲ 2514		5322 122 34123	1nF 10% X7R 50V	3526		4822 117 10833	10K 1% 0.1W
2515		4822 124 80259	1000uF 20% 25V	3528		4822 051 20561	560R 5% 0.1W
▲ 2516		5322 122 32654	22nF 10% X7R 63V				
2517		4822 124 22427	47uF 20% 40V	▲ 3529		4822 051 20472	4K7 5% 0.1W
				▲ 3530		4822 051 20472	4K7 5% 0.1W
				▲ 3532		4822 117 11744	0R22 5% 1W
				3533		4822 050 26802	6K8 1% 0.6W
				▲ 3534		4822 050 24703	47K 1% 0.6W
				3535		4822 051 10102	1K 2% 0.25W
				3536		4822 051 10102	1K 2% 0.25W
				3538		4822 051 20122	1K2 5% 0.1W
							SEMICONDUCTORS
				▲ 6500		4822 130 31982	BYV27-100
				▲ 6503			
				▲ 6504		4822 130 30621	1N4148 (COL)
				▲ 6505		4822 130 30621	1N4148 (COL)

(VERS.:VERSION, U:U.S.A., F:JAPAN, K:FAR EAST, **:EUROPE)

POS. NO	VERS. COLOR	PART NO.	DESCRIPTION
6506		4822 130 81274	MBR745
▲ 6507		4822 130 31982	BYV27-100
▲ 6509		4822 130 31982	BYV27-100
6512		4822 130 34174	BZX79-C4V7 (COL)
▲ 6513		4822 130 61219	BZX79-C1 (COL)
6514		4822 130 30862	BZX79-C9V1 (UAW)
6515		4822 130 34382	BZX79-C8V2 (COL)
▲ 6516			
I		5322 130 30684	1N4002GP
▲ 6519			
6520		4822 130 34278	BZX79-C6V8 (COL)
▲ 6521		4822 130 30621	1N4148 (COL)
6522		4822 130 34278	BZX79-C6V8 (COL)
▲ 6523		5322 130 30684	1N4002GP
▲ 6524		5322 130 30684	1N4002GP
▲ 6526		4822 130 30621	1N4148 (COL)
6529		4822 130 34195	BZX79-B13
▲ 6530		4822 130 30621	1N4148 (COL)
7500		4822 209 32063	MC34167TV
7501		5322 209 70684	LM339D
7502		4822 209 73492	L7912CV
7503		4822 130 10057	BUK545-100A
▲ 7505		4822 209 81726	L7812CV
7506		4822 209 33433	MC34064P-5
7507		4822 209 12715	L7915CV
7508		5322 130 44593	BC369
7509		5322 130 44593	BC369
▲ 7510		5322 130 41982	BC848B (UAW)
▲ 7511		5322 130 41982	BC848B (UAW)

Service Manual

CDD2000

CDR Module

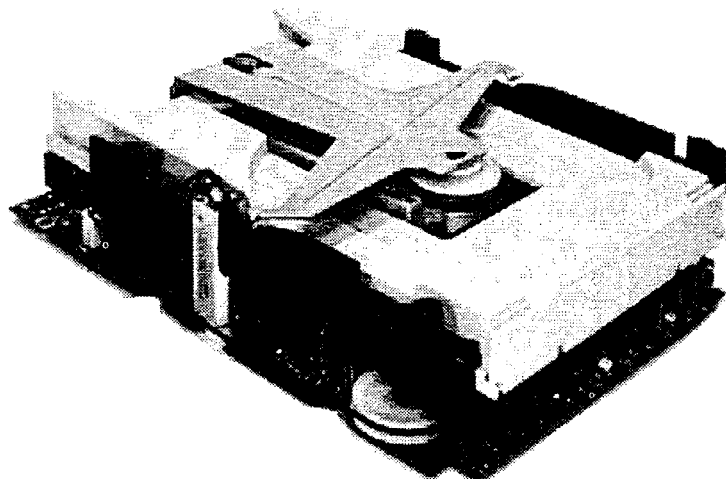

CAUTION: This part is instruction for Central repair center only.
Do not repair at local Service agent.
Please contact to MARANTZ JAPAN INC., MARANTZ EUROPE B.V. or
SUPERSCOPE TECHNOLOGIES, INC, for Central repair procedure.

TABLE OF CONTENTS

SECTION	PAGE
2.1 LIST OF ABBREVIATIONS	2-2
2.2 BLOCK DIAGRAM	2-5
2.3 SCHEMATIC DIAGRAM AND PARTS LOCATION	
SCHEMATIC DIAGRAM	
1 SERVO PART	2-8
2 ENCODING & DECODING PART & TT UP & TT MOTOR PART	2-11
3 USER CONTROL UP PART	2-14
4 BLOCK ENCODING & DSP PART	2-17
5 SCSI CONTROLLER PART	2-20
6 POWER & AUDIO OUTPUT PART	2-23
PARTS LOCATION	
COMPONENT SIDE	2-26
SOLDER SIDE	2-29
2.4 EXPLODED VIEW AND PARTS LIST	
LOADER	2-32
CDM24	2-38
2.5 ELECTRICAL PARTS LIST	2-43

model CDD2000

2.1 LIST OF ABBREVIATIONS

A1	: Calculation β and HFO
A2	: Beta = $(A1-A2)/(A1+A2)$
ACA	: Access Allowed signal
ACK	: Acknowledge serial communication user μ P
ACKA	: Port 'A' acknowledge
ACKB	: Port 'B' acknowledge
AINT	: ALPHA integrator
ALFA	: Actual absorption
ALFALS	: Absorption loop switch
ALFA0	: Absorption set value from μ P max 4.0V (0 ... 255 DAC)
ALFA3	: Absorption error detection
ALFAC	: Absorption during writing
ALLOWERR	: Allow Error
ALON	: Alpha loopswitch on
ALS	: Alpha loopswitch
AMON	: Alpha Measurement ON
AREF	: Sample value of AINT
ASTROBE	: Absorption strobe
ASY	: Interrupt request for reading Atip
ATTADS	: Attention scsi-bus
ATTBE	: Attention signal
AZIN	: + in for ALPHAO
AZREF	: - in for ALPHAO
A1	: Positive peak detector between CA and CALF
A2	: Negative peak detector between CA and CALF
A0 .. 16	: Address bus
BARCODE	: Barcode signal
BSY	: Busy (SCSI input signal)
BTARG	: Potmeter for beta target ADC for beta correction adjustment input to μ P
CA	: Central Aperture (C1+C2+C3+C4) DC -> for Mod. calculation
CAGAIN	: Power input for amplification factor of CA for servo signals
CAHFE	: CA High frequency
CALF	: CA low frequency
CALPF	: CA low pass filter
CDMLAS	: high/low power laser (jumper on laser PCB)
CECS	: Chip select CDCE
CEFS	: EFM frame sync
CEPB	: Subcode P-channel input
CERES	: Reset CDCE
CERS	: Register select CDCE
CESSY	: Subcode sync
CE INT	: CDCEP interrupt
CFLAG	: Correction flag output (CD65)
CLCE	: μ C clock output encoder (CDCEP)
CLD	: I ² S clock
CLDE	: μ C clock output decoder (CD65)
CLDS	: μ C clock output DSICR
CLIN	: I ² S clock input (CDCEP)
CLKIN	: clock signal
CLOUT	: I ² S bitclock output (CD65)
CLWP	: μ C clock Atip information CDCEP
COMCLK	: Communication clock from user μ P
CSADS	: ADS-SCSI chip select
CSCDBD	: chipselect CDBD
CSCDBE	: chipselect CDBE
CSGAIN	: Amplification factor alpha and beta measurement
C D	: Command/Data (Bidirectional SCSI signal)
C1 ... 4	: Main spots
DACE	: μ C data I/O CPCEP
DAD	: I ² S data
DADE	: μ C data CDLIP
DADS	: μ C data I/O DSICR
DAIN	: Data signal (CDCEP)
DAZFA	: See FS Limit
DAOUT	: I ² S data output (CD65)
DAWP	: μ C data Atip information (CDCEP)
DA0 ... 8	: Buffer address
DB0 ... 8	: SCSI data bus
DPH	: Delta P 20% active low, default high
DPL	: Delta P 10% active low, default high
DSSY	: Decoder subcode sync
D0 ... 7	: Data bus bit 0-7

E : E-clock microcontroller (2MHz)
 EBU : Digital output
 EFIN : Error flag signal
 EFM : Eight to fourteen modulation 2: CDCEP output for monitoring (reduced voltage from CD65 to MONON)
 EFMM : EFM N-1
 EFMCLK : EFM clock 4.3218 or 8.6436 MHz
 EFMD : Eight to fourteen modulation detect
 EFOUT : Error flag output CDROM (CD65)
 EFS : EFM flame sync output (CDCEP)
 ENINT : Enable interrupt
 ERON : Error on (servo)
 ERROR : Led indicating an error
 ERRPWM : Motor control signal input
 ERR I/O : Error input/output
 FEN : Focus error normalized = $(C1 + C3 - C2 - C4) / (C1 + C2 + C3 + C4)$
 FOC+, FOC- : Focus actuator
 FS : FS=FSO-DALFA (write power to laser control)
 FSCDM1 .. 2 : Controlled forward sense sensitivity
 FSF : Write power filtered (FS filtered)
 FSLIMIT : Control of DALPHA if FS > +4.3V diff of ALPHO and ALFAC
 FSO : Forward sense diode reference current (write power setting from μP 4.3V=DAC 0 ... 255)
 GAIN : 12cm or 8cm recordable disc (μC)
 HCA1..2 : Peak detector A1, A2
 HF : High frequency reading signal after MTF equalizing
 HMSW : Home switch
 H0 ... 7 : Host data bus
 INTADS : Interrupt request ADS
 INTSEL : Integrator to opamp or Vref (μC)
 IPPN : Current PPN
 IREAD : Laser read current
 IWRITE : Laser write current
 IX : Current X
 I-O : Input/output (bidirectional SCSI signal)
 LASPOR : Switch function (Laser current 40% higher; H=2 = high and CDM LAS = high)
 LASWR : Laser write/read
 LDCE : μC load input (from CDCEP)
 LDDE : μC load output decoder
 LDDS : μC load output DSICR
 LDON : Laser diode on (on read)
 LOCK : Lock signal from decoder
 LWRT : Laser at writing power
 MCKN : Master clock not
 MCLK : Bit clock output (CDCEP)
 MCSEL : Motor control selection
 MCSSEL : Motor control signal select
 MCTRL : Motor control switch (wobble/decoder)/tacho (μC)
 MERR : Motor control error signal
 MIRN : Mirror normalized
 MONEN : Monitor function
 MONON : Monitoring EFM from CDCEP to CD65
 MOT : Spindle motor signal
 MOTOFF : Motor off
 MREF : PWM output tacho
 MSG : Message (bidirectional SCSI signal)
 NEGAIN : Amplification factor fault signals and beta measurement
 NIRQ : Interrupt request wobble processing (CDCEP)
 NRSMP : None read sample (active low) during EFM
 NRQ : Interrupt request CDBE
 N2 : N=high (double speed)
 N2N : Switch for wobble filter
 OTD : Off track detection DISCR
 PMON : Power monitoring laser (warning to μP when FS > 4.3V)
 POWOK : Writing power ok
 PP : XB or PPN (read or write)
 PPN : Normalized push pull signal
 PPULS : Data P pulse timing
 PWR OFF : Power off detection input from user
 QCL : Q-channel clock
 QDA : Q-channel data
 QRA : Q-channel request acknowledge
 RAD+, RAD- : Radial actuator
 RADINT : Radial actuator integrator voltage
 RAO ... 8 : Ram address bus (CDB2)

RD : Read puls
RDA0 ... 7 : Ram data bus (CDB2)
READY : Led indicating drive ready
REN : Radial error normalized
RESEN : Reset CDCEP from μ P
RESET : Reset from μ P to DSICR and CD6
RESDEC : Reset decoder CXD2500Q
REQ : Request (SCSI input signal)
REQA : Port'A' request
REQB : Port'B' request
RINTOFF : Read integrator off (control Read current to Laser)
RINTON : Read integrator on
RSTADS : Reset ADS-chip
RSTIN : Reset micro controller (from user)
RW : Read/write
RXD : Receive data input (testing only)
R-W : UP read/write signal
SACK : Service acknowledge
SDAT : Servo data
SDB0 ... 8 : SCSI data bus
SDGAIN : Current to control the grating ratio of the satellite spots to the main spots
SEL : Select (SCSI input signal)
SI : Serial data communication user
SL+, SL- : Sledge motor
SO : Serial communication data output to user μ P
SPEED : Speed selection N=1/N=2
SPMOT : Spindle motor
SREQ : Servo request
SRST : Servo reset
SRSTMP : Reset servo microcontroller
SSY : Subcode sync output CDCEP
STEFM : Switch EFM tom disc/EFM tom CDCE
STOPM : Stop motor switch
SUMREF : Minimal power where above the normalizing works for servo signals
SWRT : Start write 9 μ s (one shot at start up LWRT)
SYSCLOCK : System clock
S1,S2 : Satellite spots
TACHPLS : Tacho puls input CDM
TLN : Track loss normalized
TRIN : Tray in switch
TRMOT : Tray motor control
TROUT : Tray out switch
TRS1 : Tray switch input
TRS2 : Tray switch input
TXD : Transmit data output (testing only)
UCL : Serial data transfer clock
UDAT : Serial data from CPU
ULAT : Serial data latch puls
VREF : Typical 2.5V
WINTOFF : Write integrator off (control write current to laser)
WINTON : Write integrator on
WOBL : Digital wobble after wobble filter and slicer (CDCEP to μ C)
WP0 : μ P osc. input NOT USED!
WP1 : μ P osc. input NOT USED!
WPCS : Chip select WPC
WPDEC : Motor control switch wobble/decoder
WRITE : Led indicating writing
WR : Write puls
WRLASER : Write/read laser, laser is switched with EFM timing (EFM N-1)
WRO : Selection write port 0
WRI : Selection write port 1
WSENC : Word select output from encoder (master) CDCEP
WSIN : Word select signal CDCEP
SWOUT : I²S wordselect output (CD65)
X : Fault signal X, not filtered and not normalized
XB : X balanced
XDN : X detection normalized
XFER : Indicating actual data transferring
XIRQ : Non maskable interrupt to microcontroller
XTAL : 16MHz clock output to DAC (CD65)
Y : Fault signal Y, not filtered and not normalized
4A0 ... 10 : Ram address bus (CDCE)
4M : 4x buffered clock (8MHz)
4RD0 ... 7 : Ram data bus (CDCE)

BLOCK DIAGRAM CDD2000-MODULE

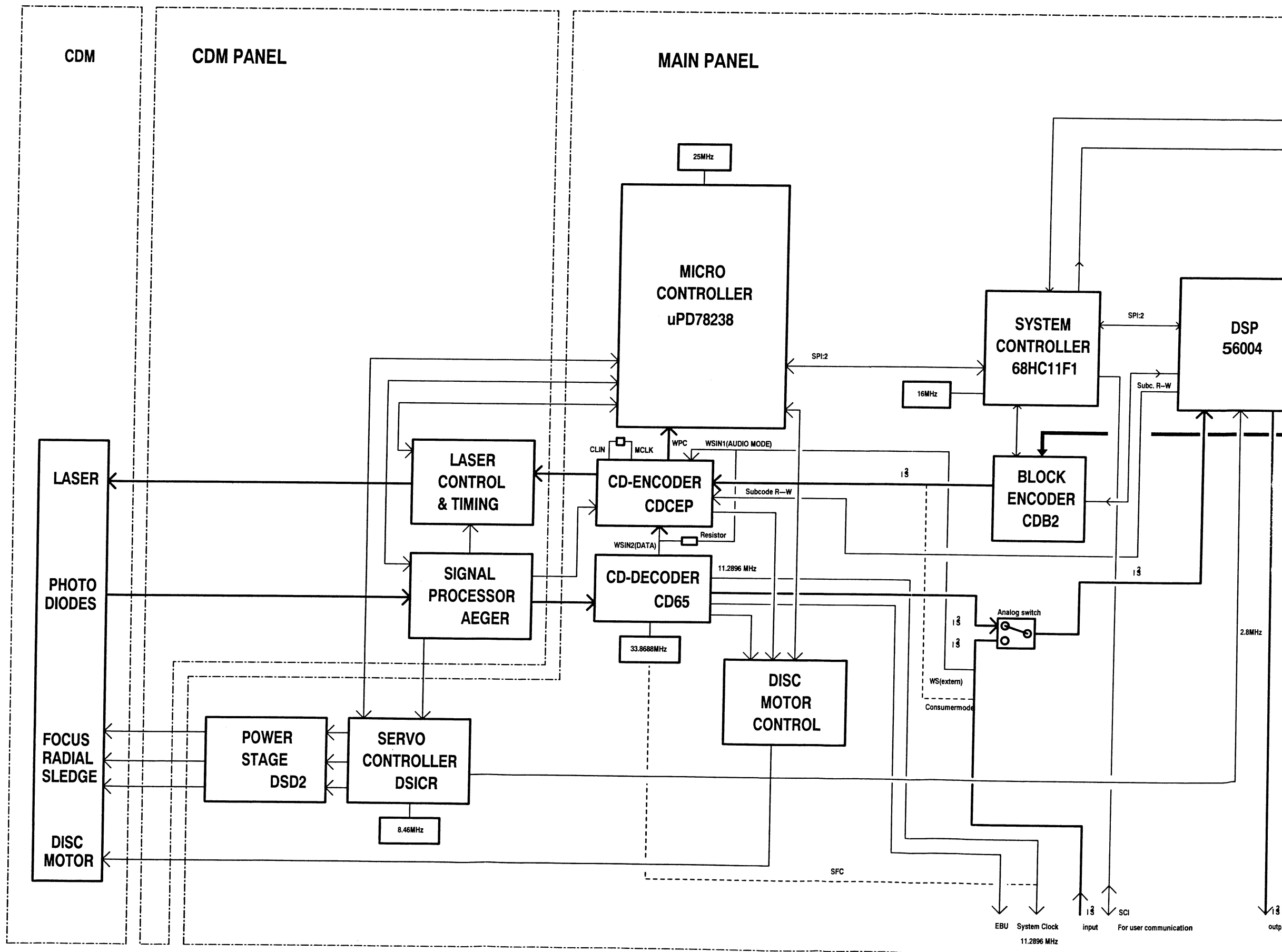

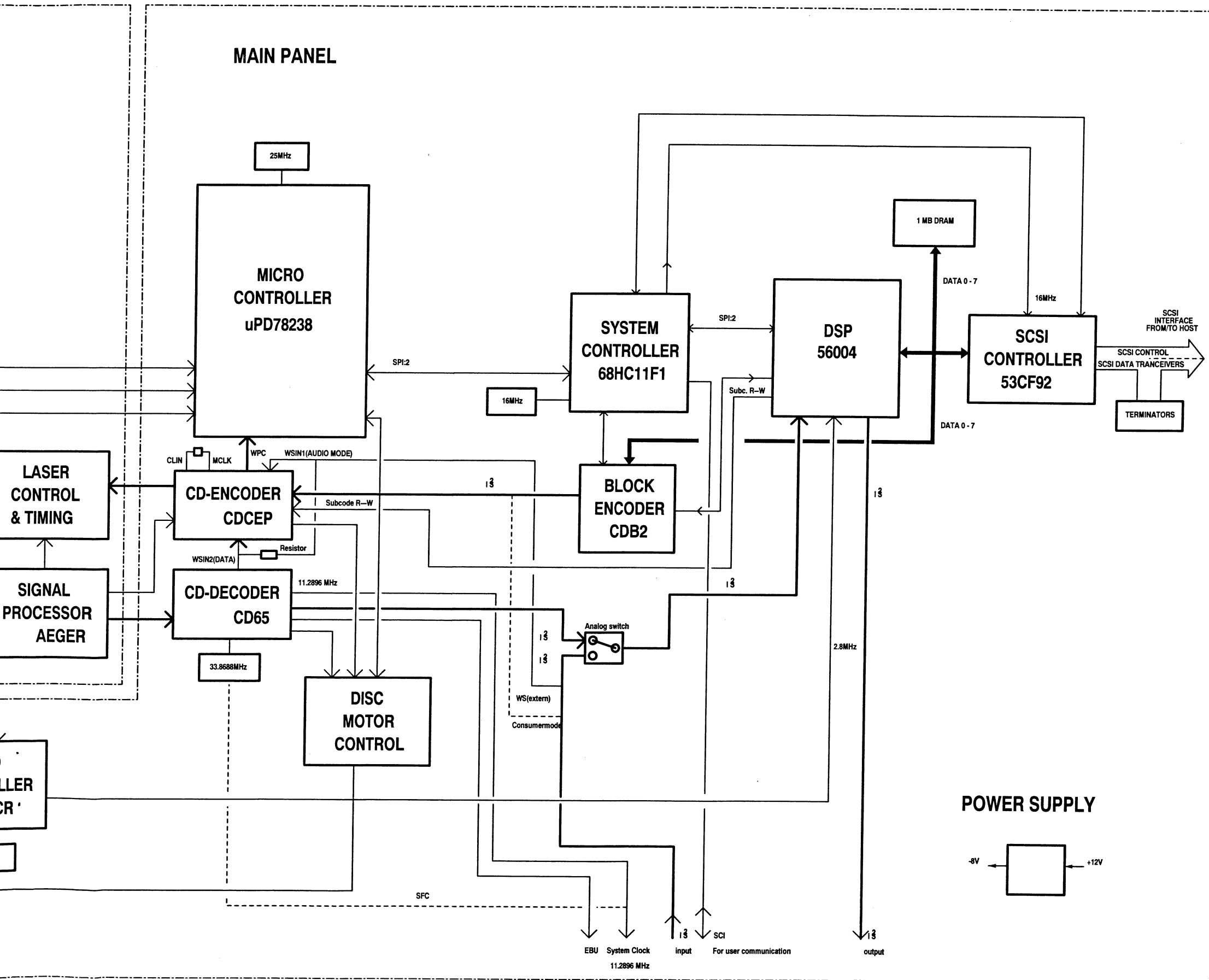

2.3 SCHEMATIC DIAGRAM AND PARTS LOCATION

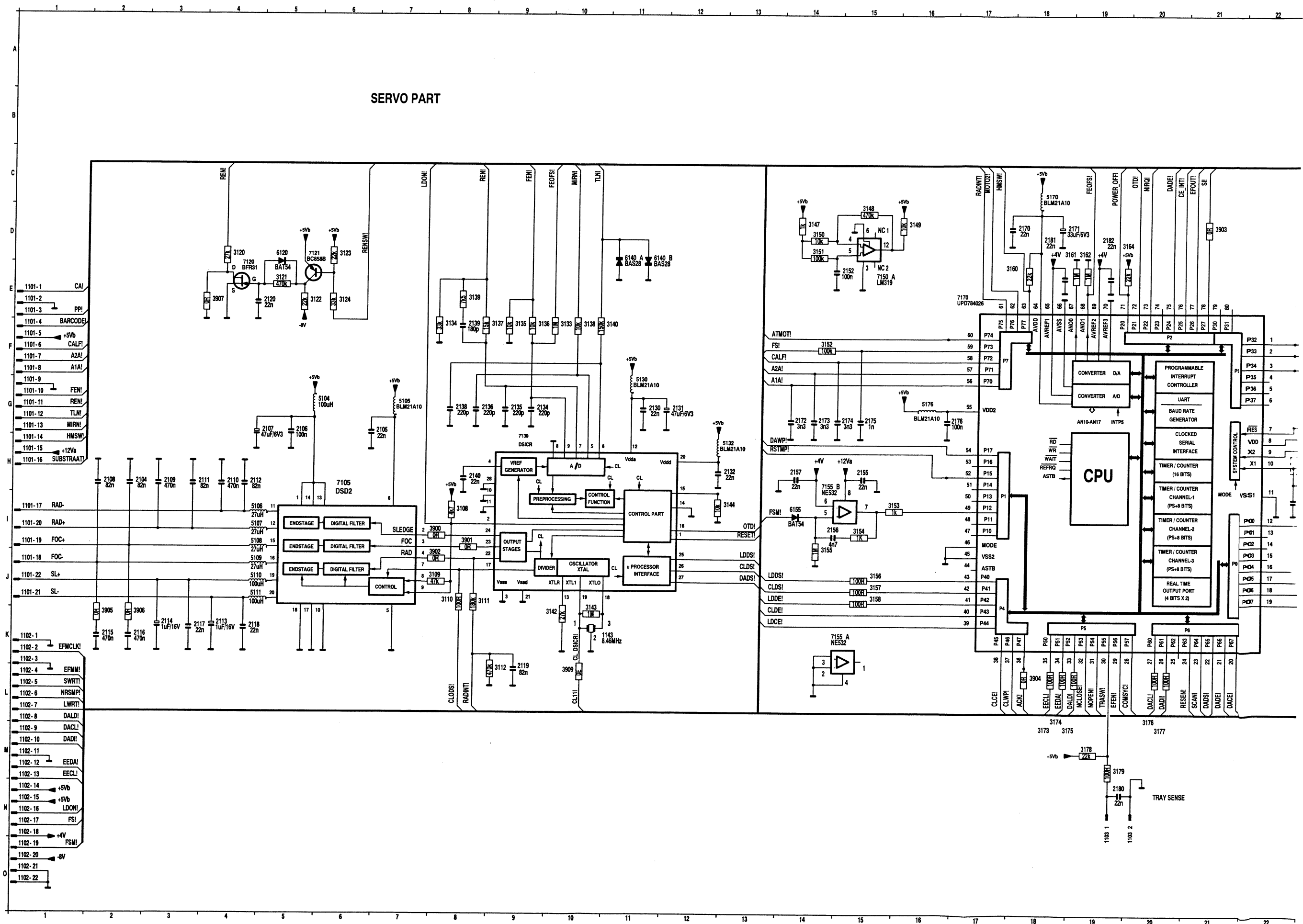

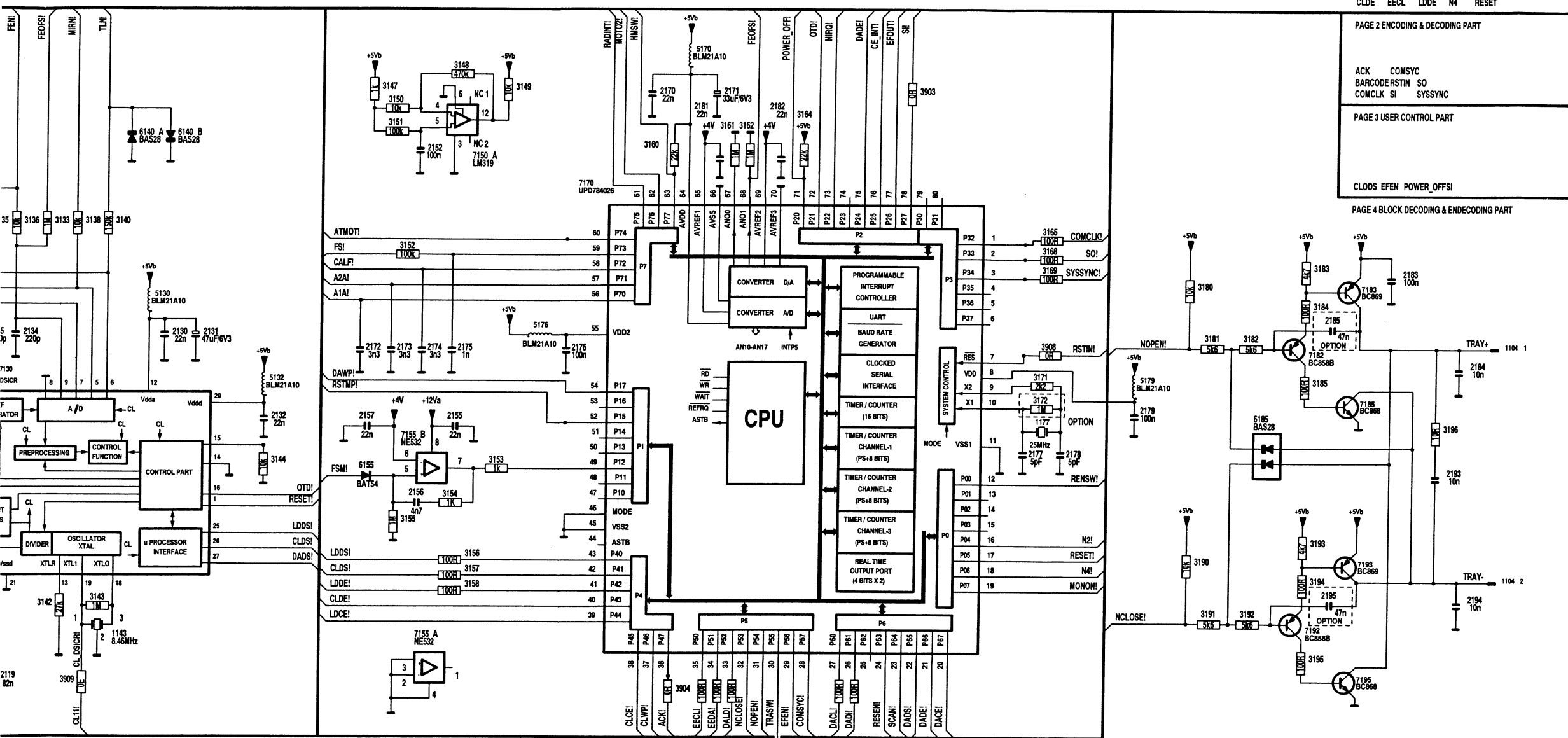

ATMOT CLWP EEDA LWRT NIRQ RSTMP
 CA DACE EFMCLK MONON NRSMP SCAN
 CE_INT DADE EFMK MOTO2 PP SWRT
 CLCE DAWP LDCE N2 RESEN
 CLDE EACL LDDE N4 RESET

PAGE 2 ENCODING & DECODING PART

ACK COMSYC
 BARCODE RSTIN SO
 COMCLK SI SYSSYNC

PAGE 3 USER CONTROL PART

CLODS EFEN POWER_OFFSI

PAGE 4 BLOCK DECODING & ENDECODING PART

A
B
C
D
E
F
G
H
I
J
K
L
M
N
O

ATMOT CLWP EEDA LWRT NIRQ
 CA DACE EFMCLK MONONRSMIP
 CE_INT DACE EFM MOTO2 PP RSTMP
 CLCE DAWP LDCE N2 RESEN SCAN
 CLDE EECL LDDE N4 RESET SWRT

PAGE1 SERVO PART
 CLTI

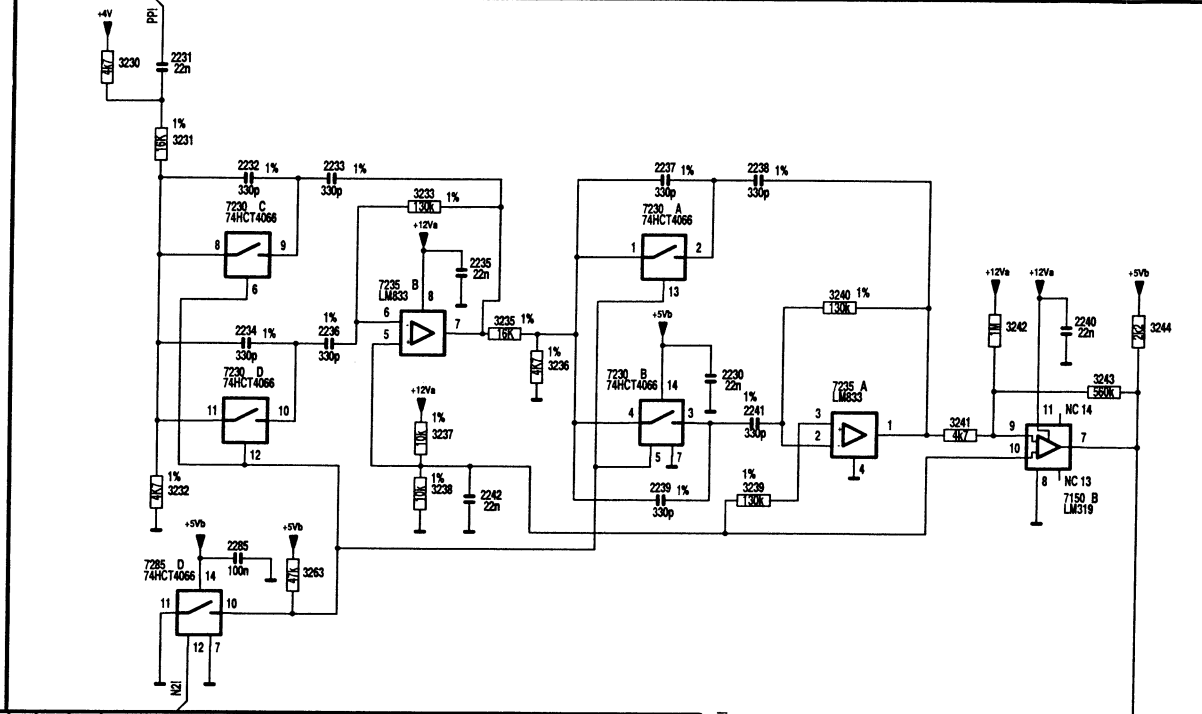

ENCODING & DECODING PART

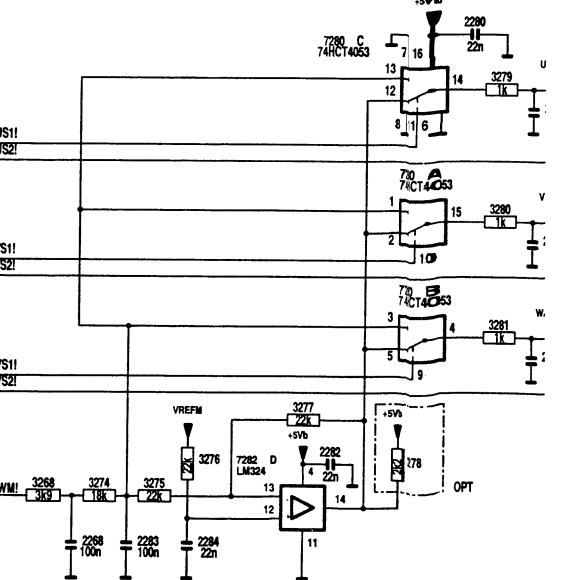
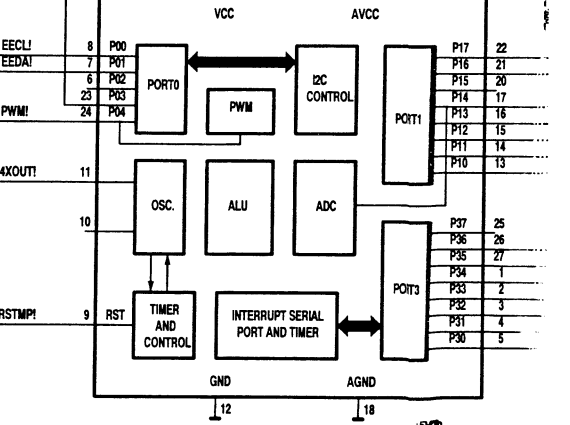
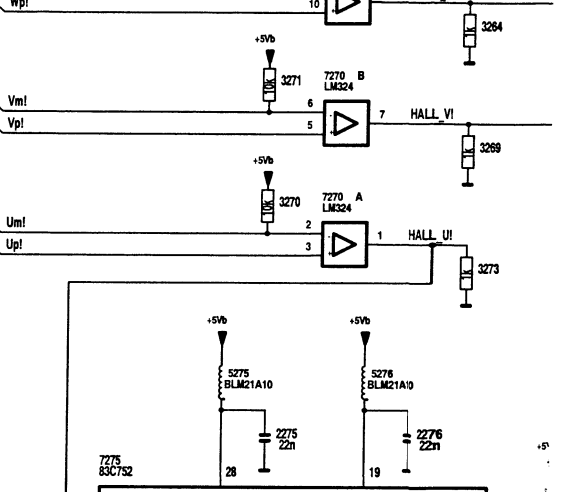
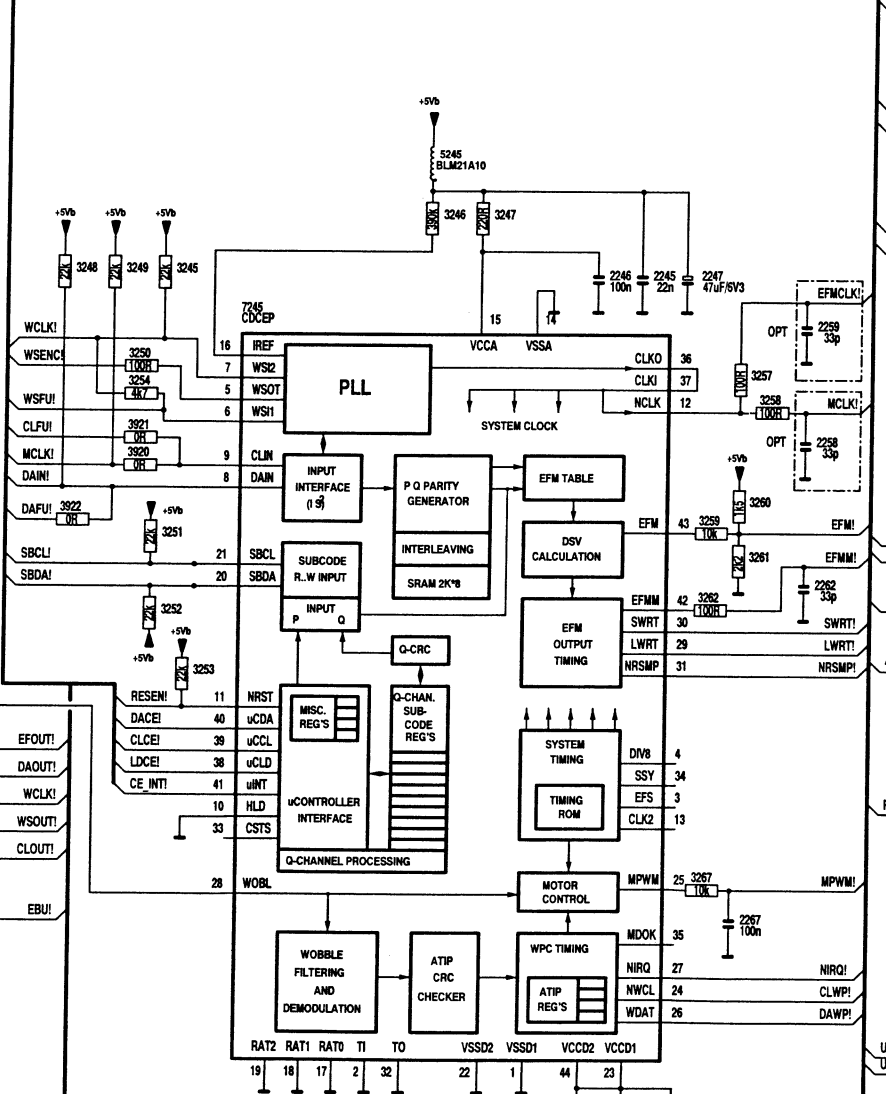

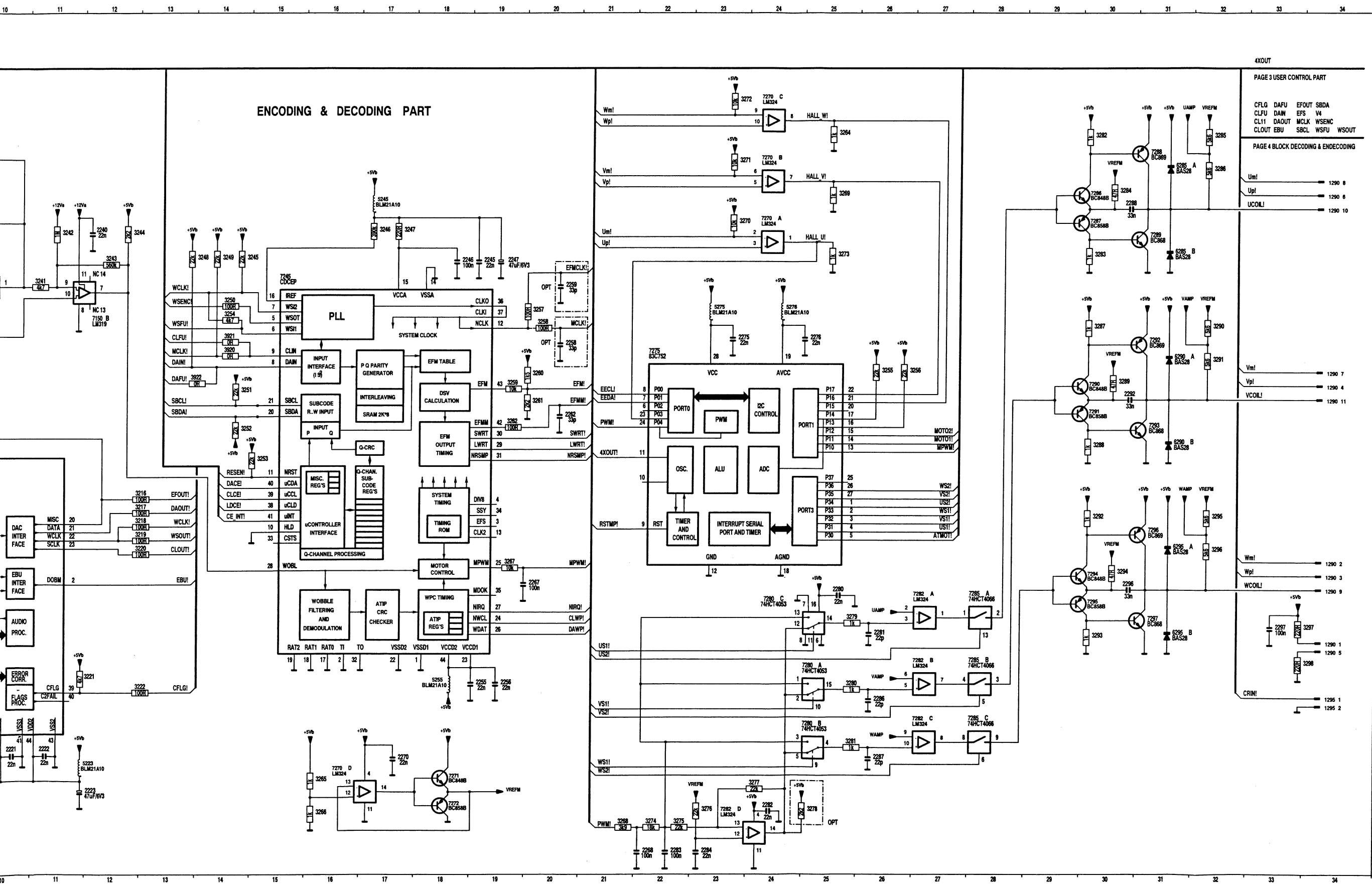

4XOUT

PAGE 3 USER CONTROL PART

CFLG DAFU EFOUT SBD A
 CLFU DAW EFS V4
 CL11 DAOUT MCLK WSENC
 CLOUT EBU SBCL WSFU WSOUT

PAGE 4 BLOCK DECODING & ENCODING

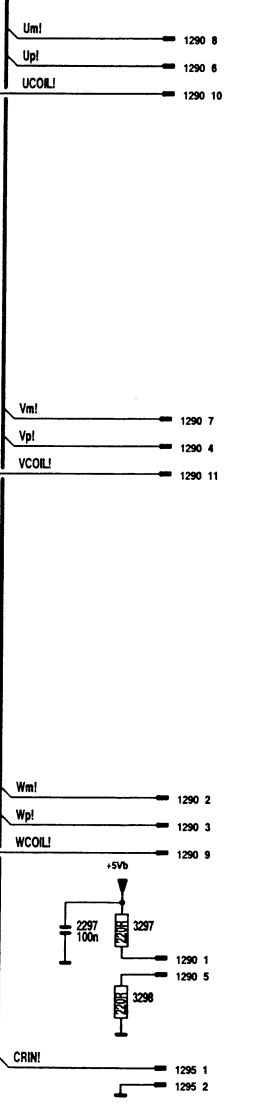

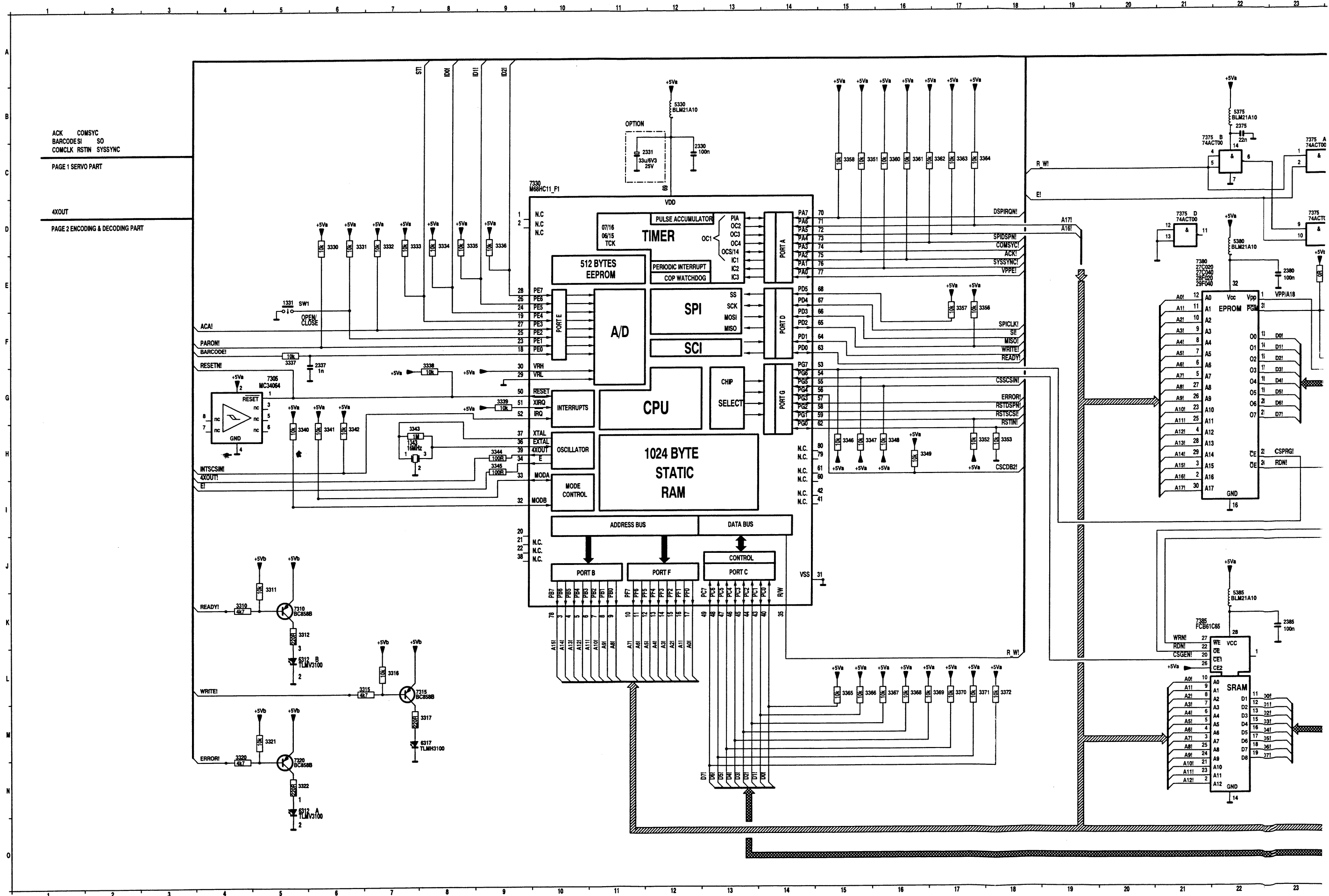

ACK COMSYC
 BARCODESI SO
 COMCLK RSTN SYSSYNC

PAGE 1 SERVO PART

4XOUT

PAGE 2 ENCODING & DECODING PART

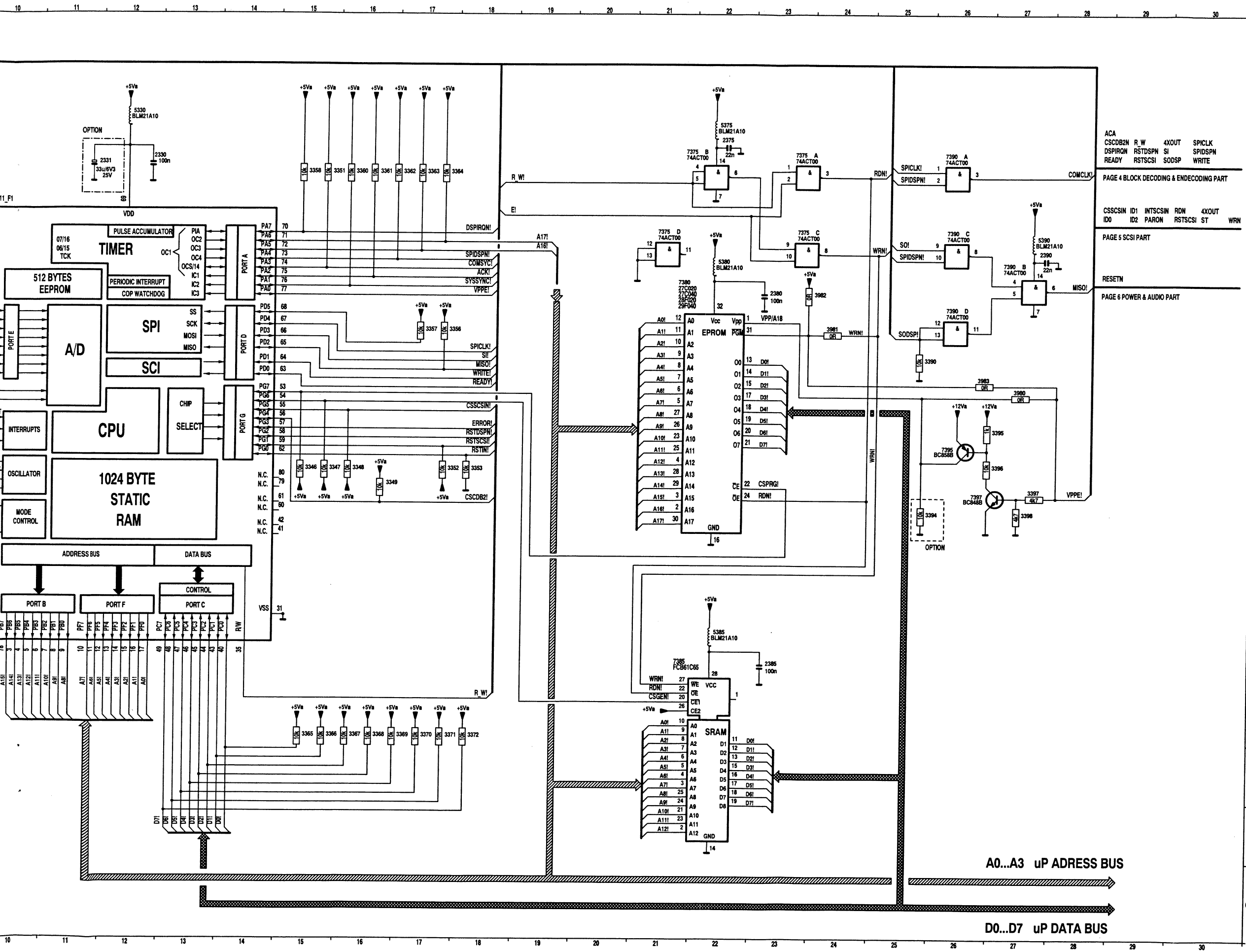

ACA
 CSCDB2N R.W 4XOUT SPICLK
 DSPIRGN RSTDSPN SI SPIDSPN
 READY RSTSCSI SODSP WRITE

PAGE 4 BLOCK DECODING & ENCODING PART

CSSCSIN ID1 INTSCSIN RDN 4XOUT
 ID0 ID2 PARON RSTSCSI ST WRN

PAGE 5 SCSI PART

RESETN

PAGE 6 POWER & AUDIO PART

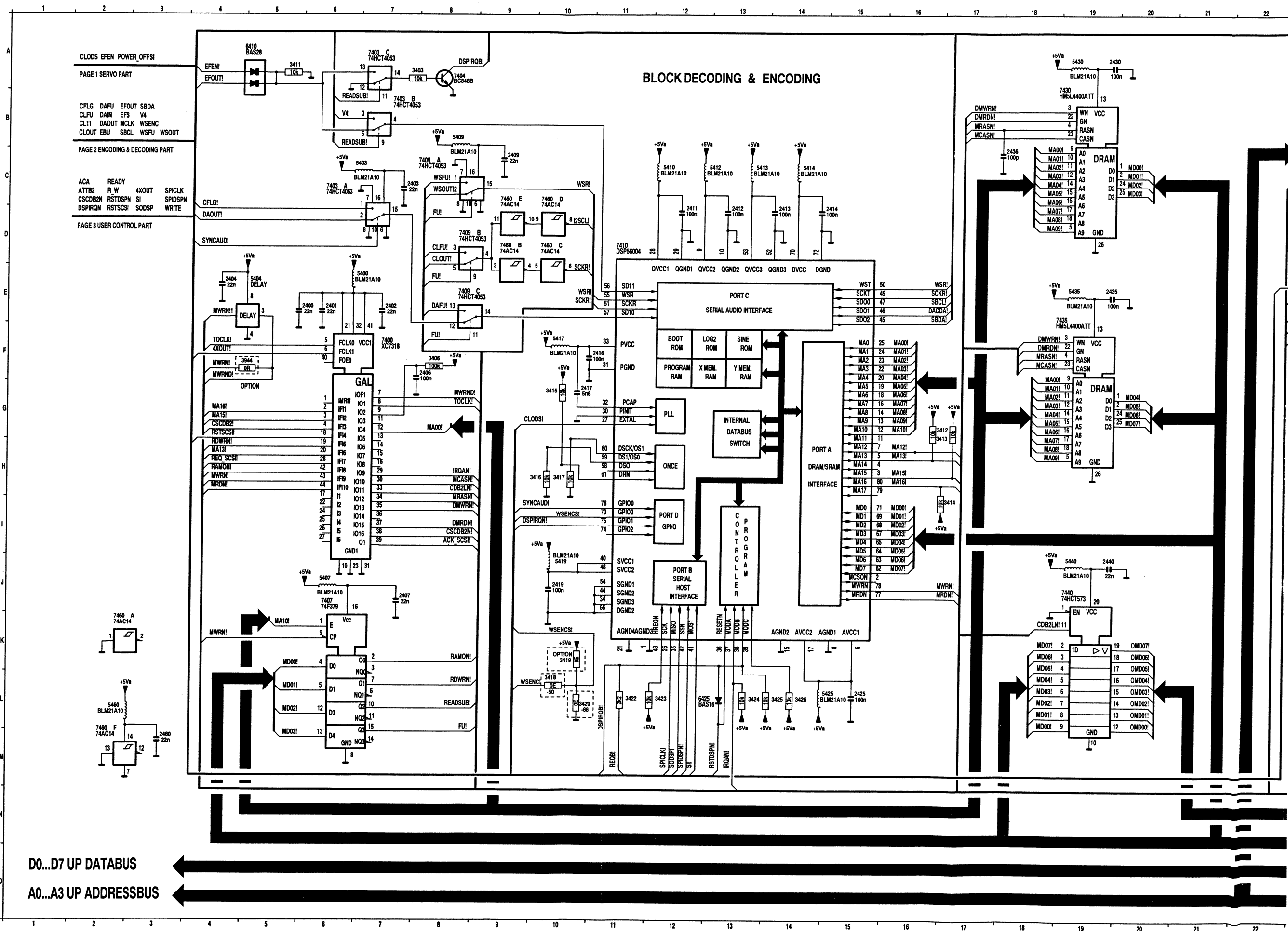

D0...D7 UP DATABUS
 A0...A3 UP ADDRESSBUS

BLOCK DECODING & ENCODING

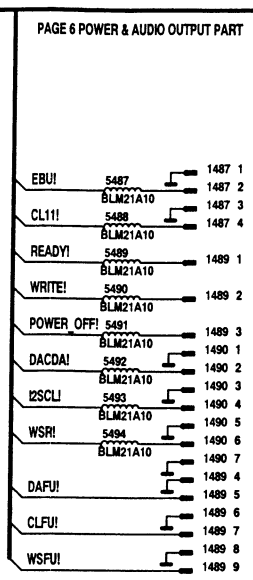
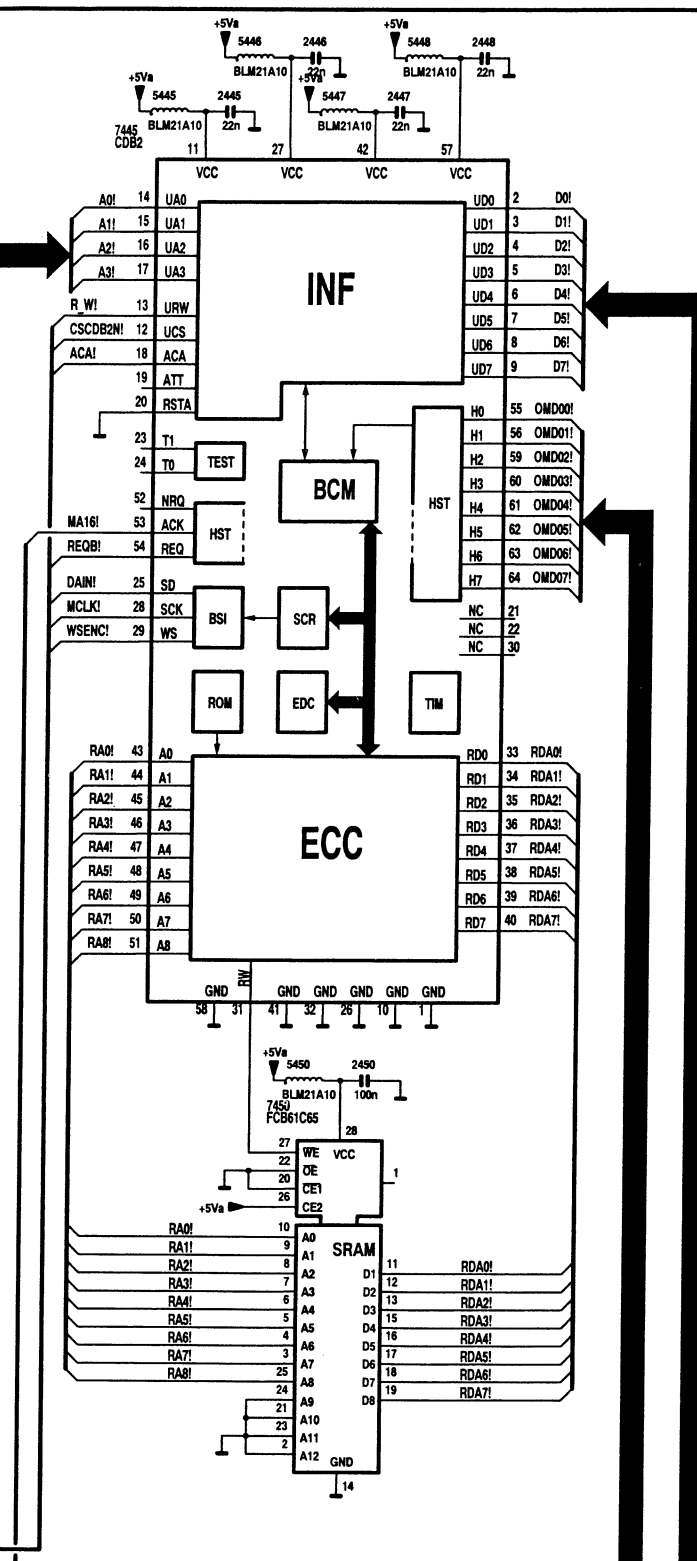
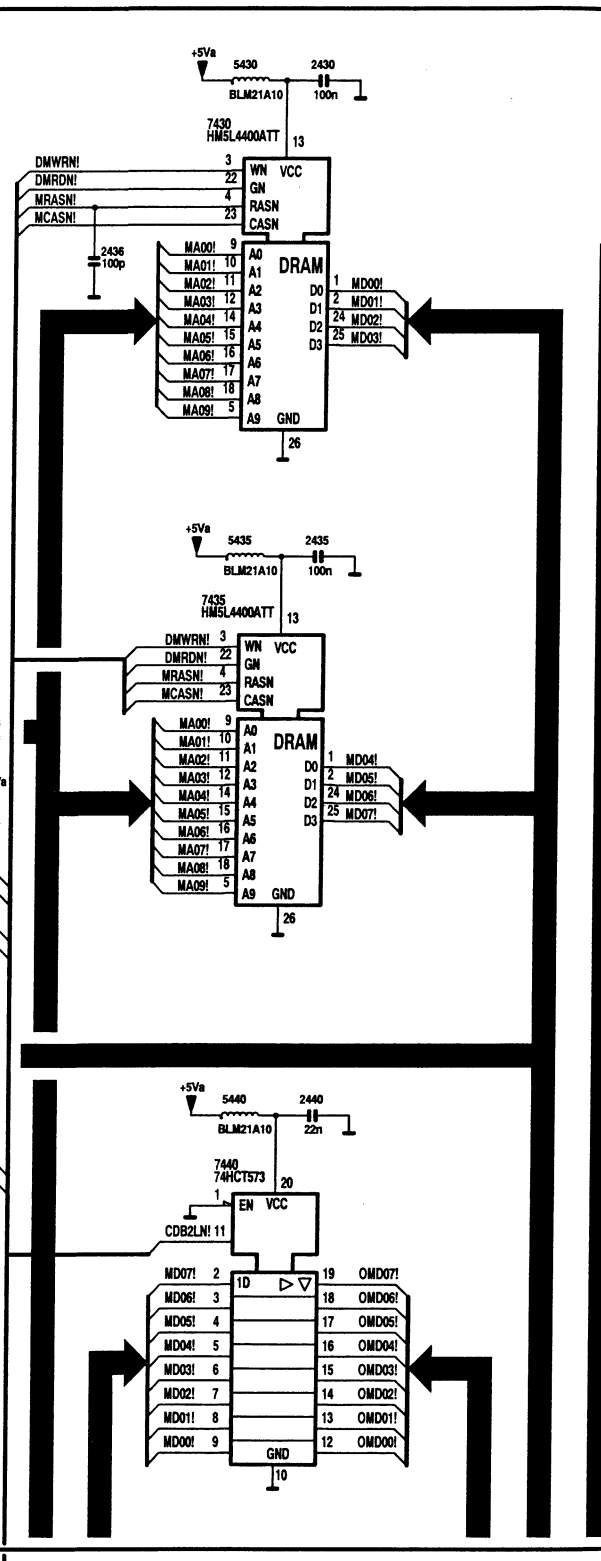
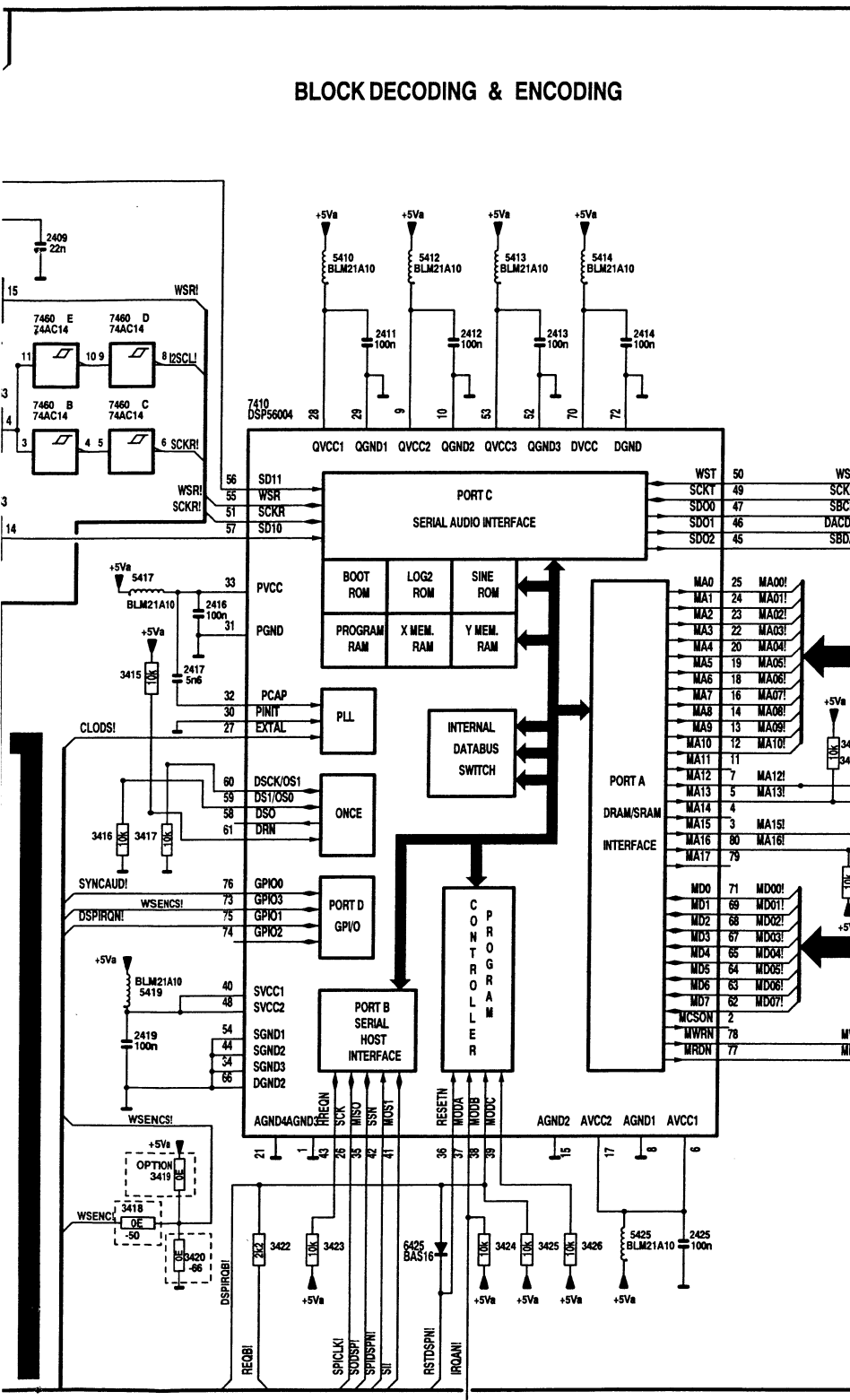

CSSCN IRQAN MA12 MWRN
PAGE 4 SCSI_DMA_BUS

MD00..MD07 MEMORY DATA_BUS
D0...D7 UP DATABUS
A0...A3 UP ADDRESSBUS

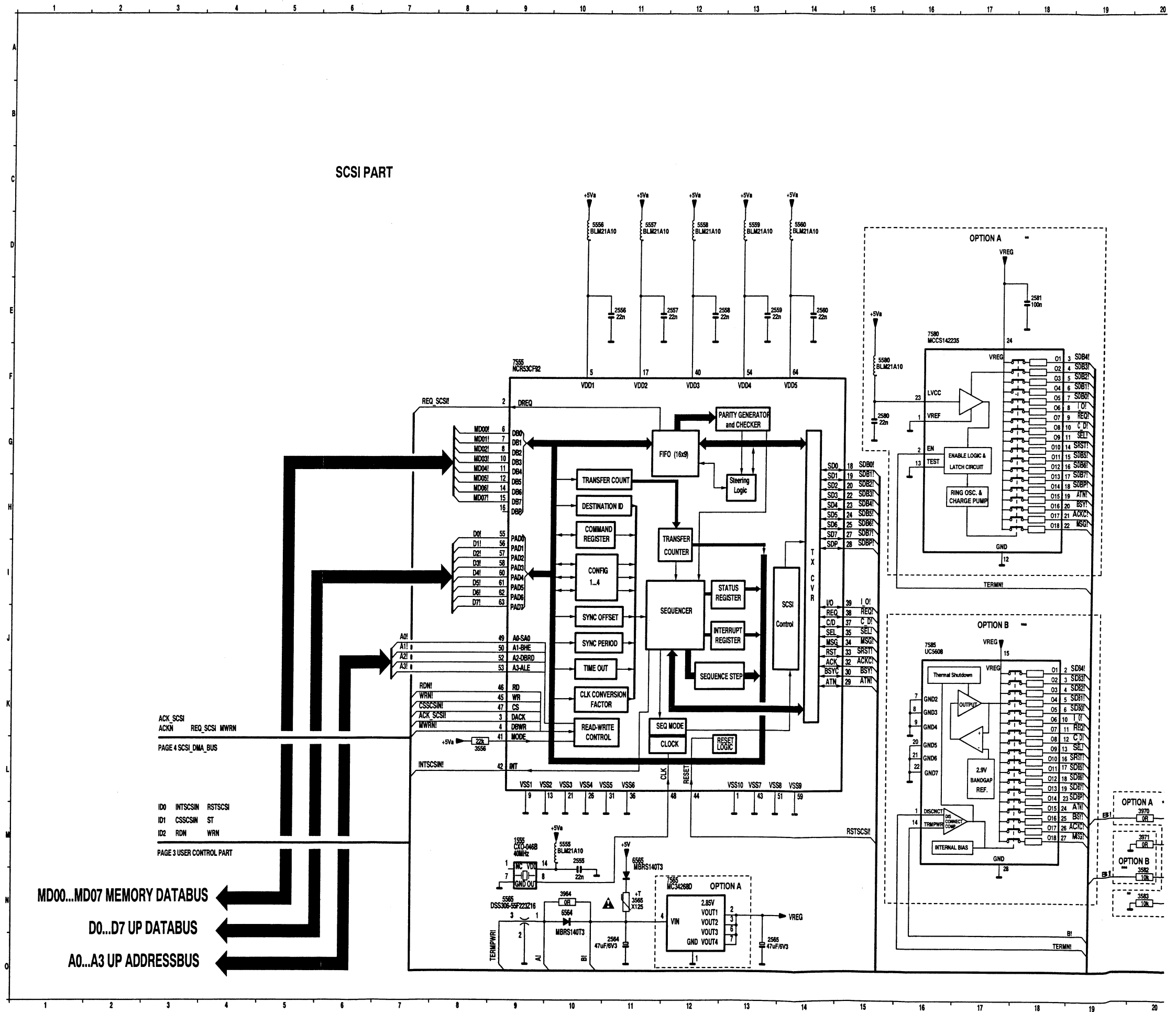

SCSI PART

MD00...MD07 MEMORY DATABUS
 D0...D7 UP DATABUS
 A0...A3 UP ADDRESSBUS

POWER & AUDIO OUTPUT PART

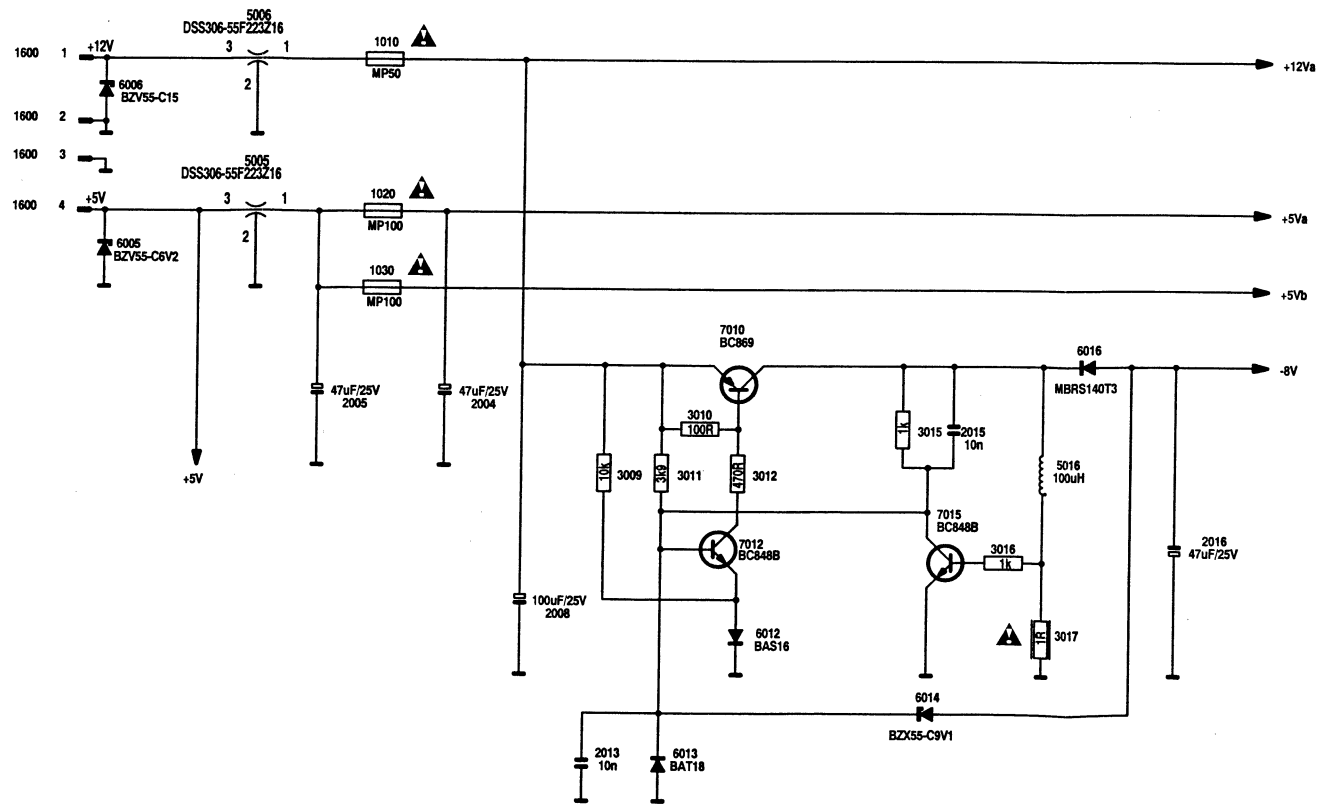

R& AUDIO OUTPUT PART

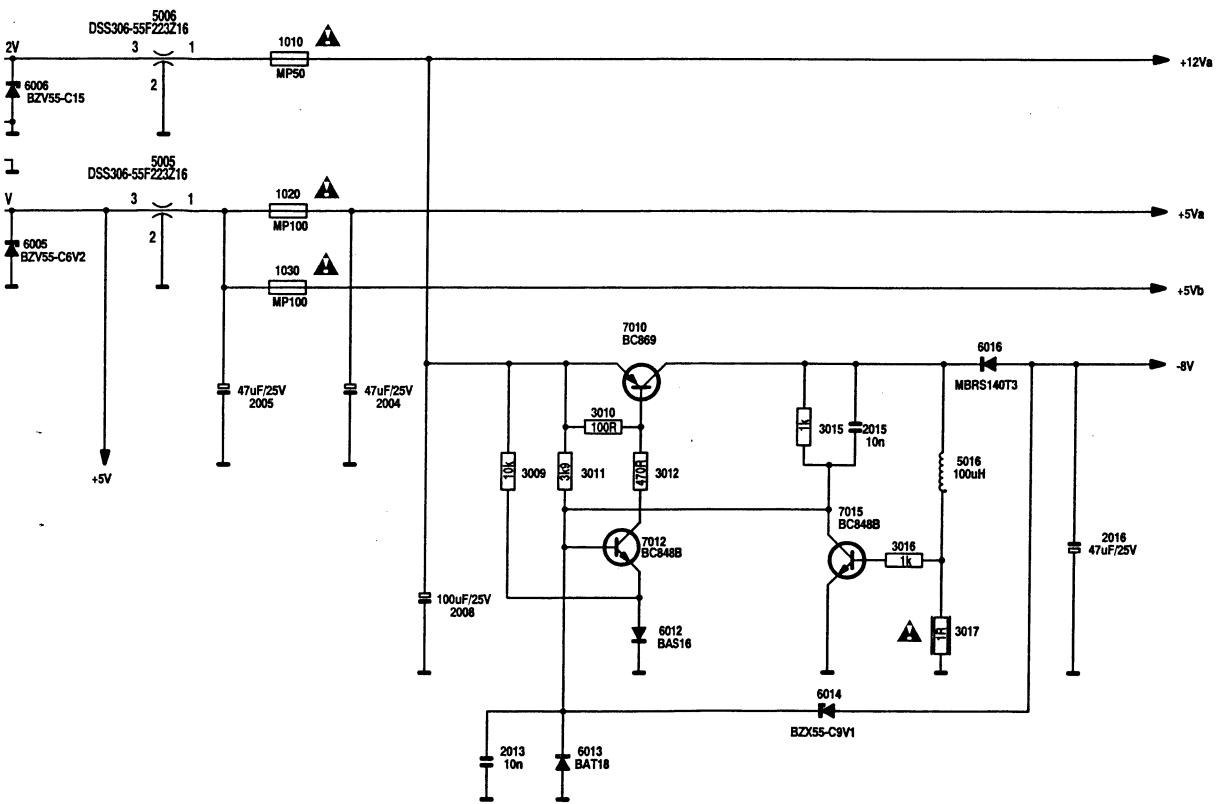

COMPONENT SIDE

1

2

3

4

5

6

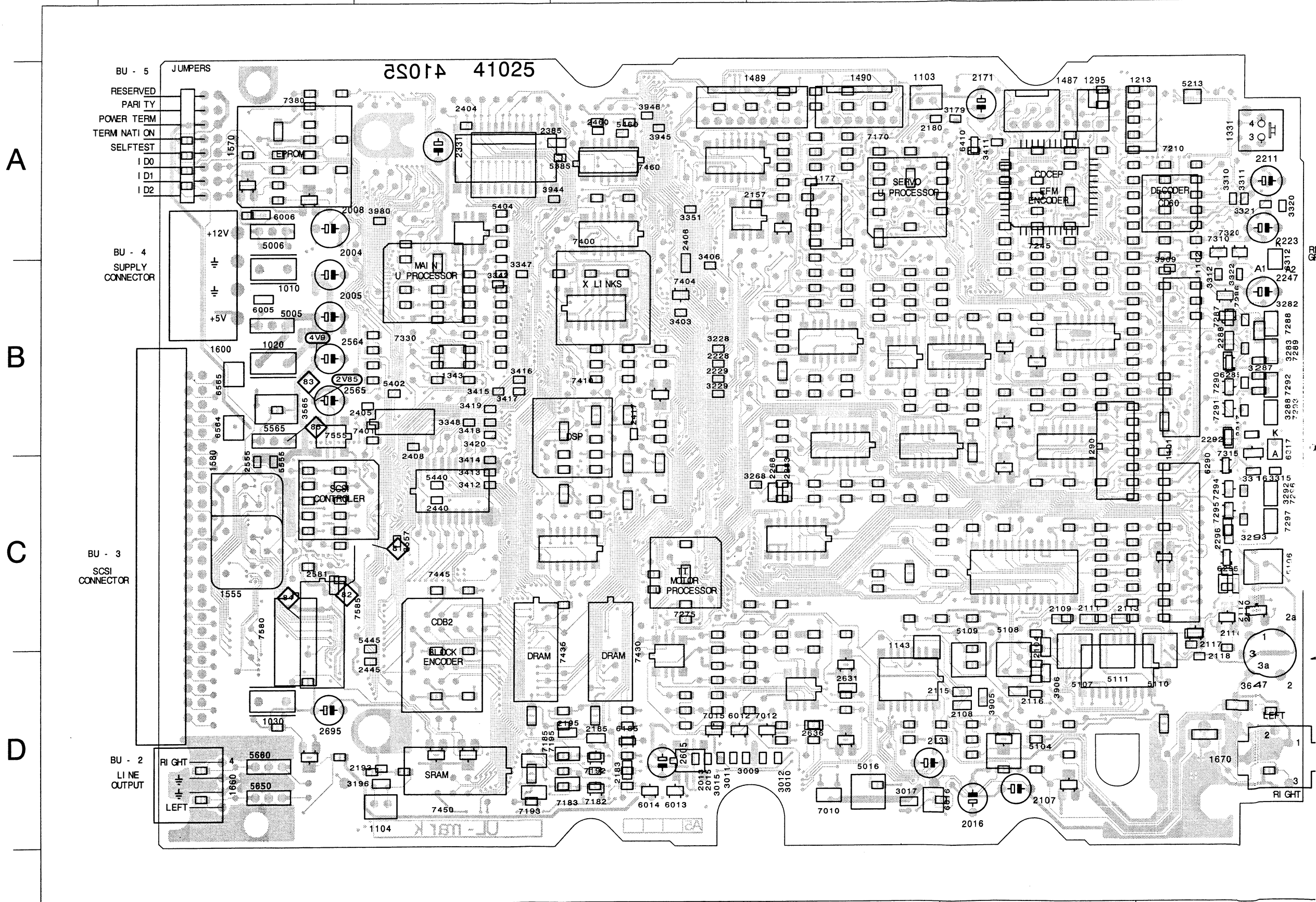

1

2

3

4

5

6

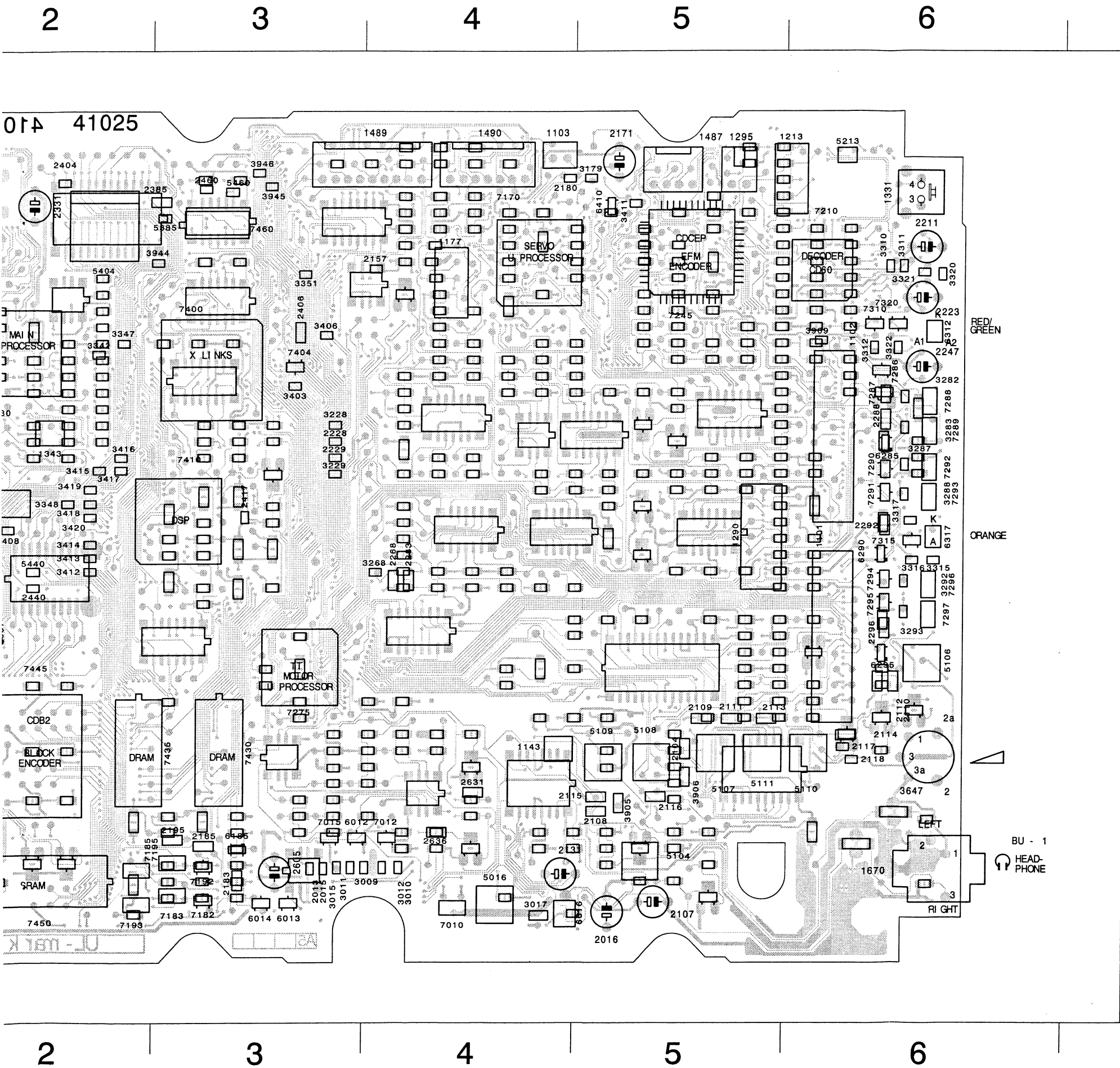

1010 B 1	2440 C 2	5106 C 6	7435 D 2
1020 B 1	2445 D 2	5107 D 5	7445 D 2
1030 D 1	2460 A 3	5108 D 5	7450 D 2
1101 C 6	2555 C 1	5109 D 5	7460 A 3
1102 B 6	2564 B 1	5110 D 6	7555 C 1
1103 A 4	2565 B 1	5111 D 5	7580 C 1
1104 D 2	2581 C 1	5213 A 6	7585 C 1
1143 D 4	2605 D 3	5385 A 3	
1177 A 4	2631 D 4	5402 B 2	
1213 A 6	2636 D 4	5404 A 2	
1290 C 5	2695 D 1	5440 C 2	
1295 A 5	3009 D 4	5445 C 2	
1331 A 6	3010 D 4	5460 A 3	
1343 B 2	3011 D 3	5555 C 1	
1487 A 5	3012 D 4	5565 B 1	
1489 A 4	3015 D 3	5650 D 1	
1490 A 4	3017 D 4	5660 D 1	
1555 C 1	3179 A 5	6005 B 1	
1570 A 1	3196 D 2	6006 A 1	
1580 C 1	3228 B 3	6012 D 3	
1600 B 1	3229 B 3	6013 D 3	
1660 D 1	3268 C 4	6014 D 3	
1670 D 6	3282 B 6	6016 D 4	
2004 B 1	3283 B 6	6185 D 3	
2005 B 1	3287 B 6	6285 B 6	
2008 A 1	3288 B 6	6290 C 6	
2013 D 3	3292 C 6	6295 C 6	
2015 D 3	3293 C 6	6312 B 6	
2016 D 5	3310 A 6	6317 C 6	
2104 D 5	3311 A 6	6410 A 5	
2107 D 5	3312 B 6	6564 B 1	
2108 D 5	3315 C 6	6565 B 1	
2109 C 5	3316 C 6	7010 D 4	
2110 C 6	3317 B 6	7012 D 4	
2111 C 5	3320 A 6	7015 D 3	
2112 C 6	3321 A 6	7170 A 4	
2113 C 5	3322 B 6	7182 D 3	
2114 C 6	3342 B 2	7183 D 3	
2115 D 5	3347 B 2	7185 D 2	
2116 D 5	3348 B 2	7192 D 3	
2117 C 6	3351 A 3	7193 D 2	
2118 D 6	3403 B 3	7195 D 3	
2131 D 4	3406 B 3	7210 A 6	
2157 A 4	3411 A 5	7245 A 5	
2171 A 5	3412 C 2	7275 C 3	
2180 A 4	3413 C 2	7286 B 6	
2183 D 3	3414 C 2	7287 B 6	
2185 D 3	3415 B 2	7288 B 6	
2193 D 2	3416 B 2	7289 B 6	
2195 D 3	3417 B 2	7290 B 6	
2211 A 6	3418 B 2	7291 B 6	
2223 A 6	3419 B 2	7292 B 6	
2228 B 3	3420 B 2	7293 B 6	
2229 B 3	3557 C 2	7294 C 6	
2247 B 6	3565 B 1	7295 C 6	
2268 C 4	3647 D 6	7296 C 6	
2283 C 4	3905 D 5	7297 C 6	
2288 B 6	3906 D 5	7310 A 6	
2292 B 6	3909 B 6	7315 C 6	
2296 C 6	3944 A 3	7320 A 6	
2331 A 2	3945 A 3	7330 B 2	
2385 A 3	3946 A 3	7380 A 1	
2404 A 2	3980 A 2	7400 B 3	
2405 B 2	5005 B 1	7401 B 2	
2406 B 3	5006 A 1	7404 B 3	
2408 B 2	5016 D 4	7410 B 3	
2417 B 3	5104 D 5	7430 D 3	

SOLDER SIDE

6

5

4

3

2

1

A

B

C

D

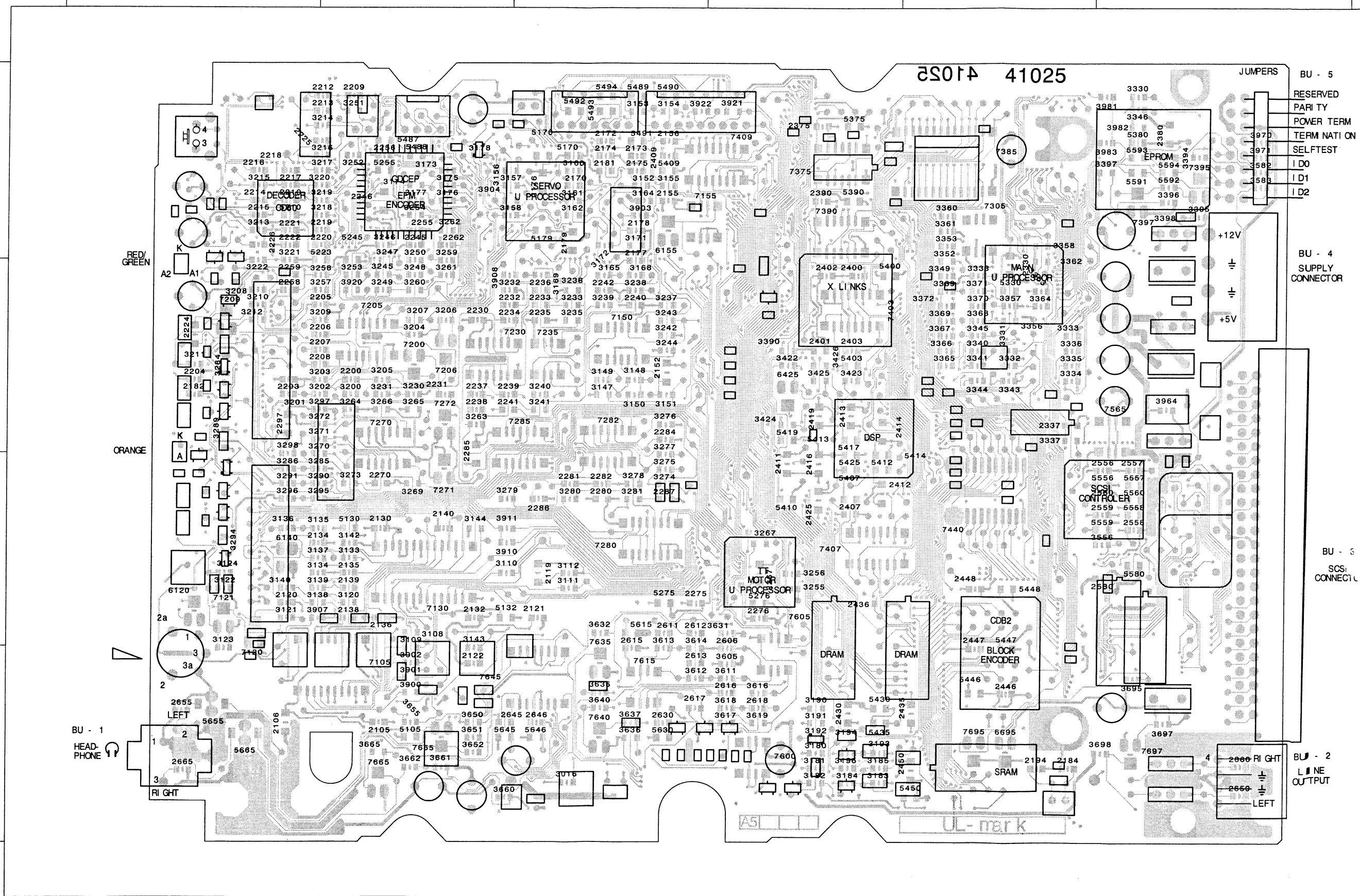

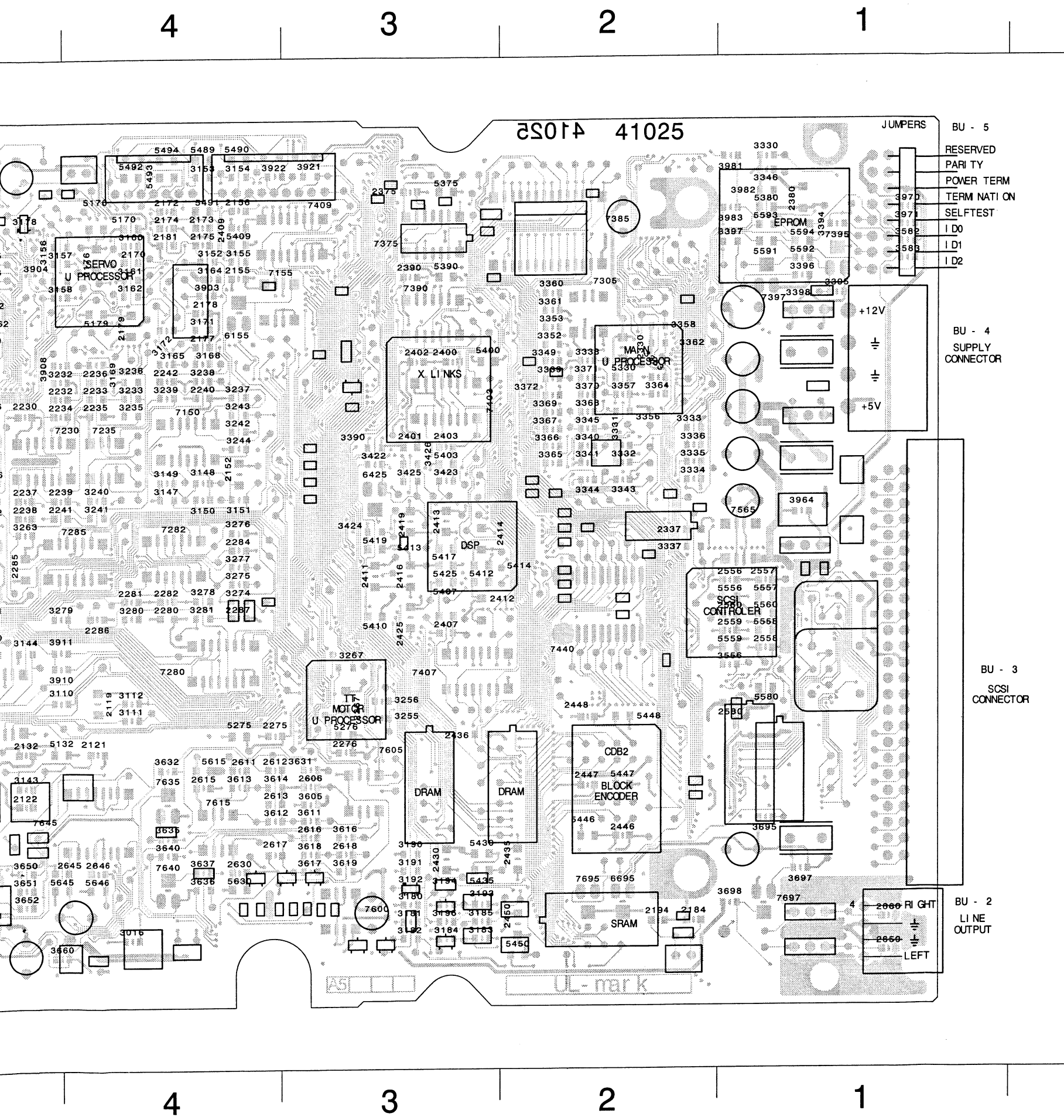

2105 D 5	2246 A 5	3110 C 5	3209 B 5	3289 B 6	3632 C 4
2106 D 6	2255 A 5	3111 C 4	3210 B 6	3290 C 5	3635 D 4
2119 C 4	2256 A 5	3112 C 4	3211 B 6	3291 C 6	3636 D 4
2120 C 6	2258 B 6	3120 C 5	3212 B 6	3294 C 6	3637 D 4
2121 C 4	2259 B 6	3121 C 6	3213 A 6	3295 C 5	3640 D 4
2122 D 5	2262 A 5	3122 C 6	3214 A 5	3296 C 6	3650 D 5
2130 C 5	2267 C 3	3123 D 6	3215 A 6	3297 B 5	3651 D 5
2132 C 5	2270 C 5	3124 C 6	3216 A 5	3298 C 6	3652 D 5
2134 C 5	2275 C 4	3133 C 5	3217 A 5	3330 A 1	3655 D 5
2135 C 5	2276 C 3	3134 C 5	3218 A 5	3331 B 2	3660 D 5
2136 C 5	2280 C 4	3135 C 5	3219 A 5	3332 B 2	3661 D 5
2138 C 5	2281 C 4	3136 C 6	3220 A 5	3333 B 2	3662 D 5
2139 C 5	2282 C 4	3137 C 5	3221 B 6	3334 B 2	3665 D 5
2140 C 5	2284 B 4	3138 C 5	3222 B 6	3335 B 2	3695 D 1
2152 B 4	2285 C 5	3139 C 5	3230 B 5	3336 B 2	3697 D 1
2155 A 4	2286 C 4	3140 C 6	3231 B 5	3337 B 2	3698 D 1
2156 A 4	2287 C 4	3142 C 5	3232 B 5	3338 B 2	3900 D 5
2170 A 4	2297 B 6	3143 D 5	3233 B 4	3339 B 2	3901 D 5
2172 A 4	2330 B 2	3144 C 5	3235 B 4	3340 B 2	3902 D 5
2173 A 4	2337 B 2	3147 B 4	3236 B 4	3341 B 2	3903 A 4
2174 A 4	2375 A 3	3148 B 4	3237 B 4	3343 B 2	3904 A 5
2175 A 4	2380 A 1	3149 B 4	3238 B 4	3344 B 2	3907 C 5
2176 A 4	2390 A 3	3150 B 4	3239 B 4	3345 B 2	3908 B 5
2177 B 4	2400 B 3	3151 B 4	3240 B 4	3346 A 1	3910 C 5
2178 A 4	2401 B 3	3152 A 4	3241 B 4	3349 B 2	3911 C 5
2179 A 4	2402 B 3	3153 A 4	3242 B 4	3352 B 2	3920 B 5
2181 A 4	2403 B 3	3154 A 4	3243 B 4	3353 A 2	3921 A 3
2182 B 6	2407 C 3	3155 A 4	3244 B 4	3356 B 2	3922 A 4
2184 D 2	2409 A 4	3156 A 5	3245 B 5	3357 B 2	3964 B 1
2194 D 2	2411 C 3	3157 A 5	3246 A 5	3358 A 2	3970 A 1
2200 B 5	2412 C 3	3158 A 5	3247 A 5	3360 A 2	3971 A 1
2203 B 6	2413 B 3	3160 A 4	3248 B 5	3361 A 2	3981 A 1
2204 B 6	2414 B 3	3161 A 4	3249 B 5	3362 B 2	3982 A 1
2205 B 5	2416 C 3	3162 A 4	3250 B 5	3363 B 2	3983 A 1
2206 B 5	2419 B 3	3164 A 4	3251 A 5	3364 B 2	5105 D 5
2207 B 5	2425 C 3	3165 B 4	3252 A 5	3365 B 2	5130 C 5
2208 B 5	2430 D 3	3168 B 4	3253 B 5	3366 B 2	5132 C 5
2209 A 5	2435 D 2	3169 B 4	3254 A 5	3367 B 2	5170 A 4
2210 A 6	2436 C 3	3171 A 4	3255 C 3	3368 B 2	5176 A 4
2212 A 5	2446 D 2	3172 A 4	3256 C 3	3369 B 2	5179 A 4
2213 A 5	2447 D 2	3173 A 5	3257 B 5	3370 B 2	5210 A 6
2214 A 6	2448 C 2	3174 A 5	3258 B 5	3371 B 2	5223 B 5
2215 A 6	2450 D 2	3175 A 5	3259 B 5	3372 B 2	5245 B 5
2216 A 6	2556 C 1	3176 A 5	3260 B 5	3390 B 3	5255 A 5
2217 A 6	2557 C 1	3177 A 5	3261 B 5	3394 A 1	5275 C 4
2218 A 6	2558 C 1	3178 A 5	3262 A 5	3395 A 1	5276 C 3
2219 A 5	2559 C 1	3180 D 3	3263 B 5	3396 A 1	5330 B 2
2220 A 5	2560 C 1	3181 D 3	3264 B 5	3397 A 1	5375 A 3
2221 A 6	2580 C 1	3182 D 3	3265 B 5	3398 A 1	5380 A 1
2222 A 6	2606 C 3	3183 D 3	3266 B 5	3422 B 3	5390 A 3
2224 B 6	2611 C 4	3184 D 3	3267 C 3	3423 B 3	5400 B 3
2225 A 5	2612 C 4	3185 D 3	3269 C 5	3424 B 3	5403 B 3
2226 A 6	2613 D 4	3190 D 3	3270 C 5	3425 B 3	5407 C 3
2230 B 5	2615 D 4	3191 D 3	3271 B 5	3426 B 3	5409 A 4
2231 B 5	2616 D 3	3192 D 3	3272 B 5	3556 C 1	5410 C 3
2232 B 5	2617 D 4	3193 D 3	3273 C 5	3582 A 1	5412 C 3
2233 B 4	2618 D 3	3194 D 3	3274 C 4	3583 A 1	5413 B 3
2234 B 5	2630 D 4	3195 D 3	3275 C 4	3605 D 3	5414 C 3
2235 B 4	2645 D 5	3200 B 5	3276 B 4	3611 D 3	5417 C 3
2236 B 4	2646 D 4	3201 B 6	3277 C 4	3612 D 4	5419 B 3
2237 B 5	2650 D 1	3202 B 5	3278 C 4	3613 D 4	5425 C 3
2238 B 5	2655 D 6	3203 B 5	3279 C 5	3614 D 4	5430 D 3
2239 B 5	2660 D 1	3204 B 5	3280 C 4	3616 D 3	5435 D 3
2240 B 4	2665 D 6	3205 B 5	3281 C 4	3617 D 3	5446 D 2
2241 B 5	3016 D 4	3206 B 5	3284 B 6	3618 D 3	5447 D 2
2242 B 4	3108 C 5	3207 B 5	3285 C 5	3619 D 3	5448 C 2
2245 A 5	3109 D 5	3208 B 6	3286 C 6	3631 C 3	5450 D 2

2.4 EXPLODED VIEWS AND PARTS LIST LOADER

(VERS.:VERSION, U:U.S.A., F:JAPAN, K:FAR EAST, **:EUROPE)

POS. NO	VERS. COLOR	PART NO.	DESCRIPTION
1		4822 464 51086	CHASSIS ASSY
15		4822 325 60379	DAMPING GROMMET
20		4822 361 21758	TRAY MOTOR ASSY
25		4822 276 13608	SWITCH ASSY
26		4822 277 10749	SWITCH
41		4822 464 51084	SUB-CHASSIS
46		4822 492 71688	EXTENSION
47		4822 325 60379	DAMPING GROMMET
48		4822 492 71686	CLAMPER SPRING
49		4822 535 93546	PULL-ROD
54		4822 466 83201	CLAMPER PLATE
55		4822 532 52676	CLAMPER
58		4822 492 52426	COMPRESSION SPRING
70		4822 444 10173	TRAY ASSY
80		4822 358 10149	BELT

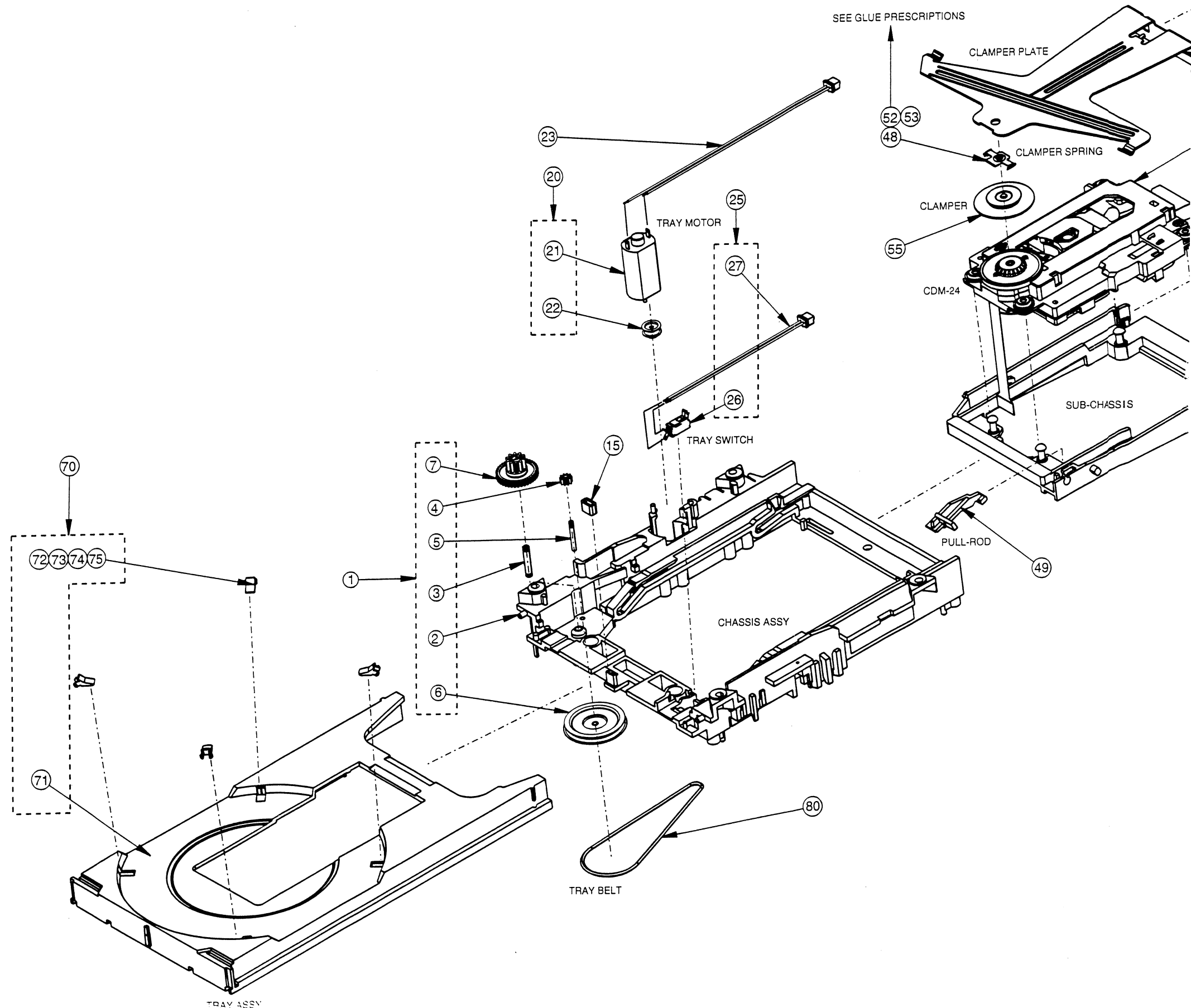

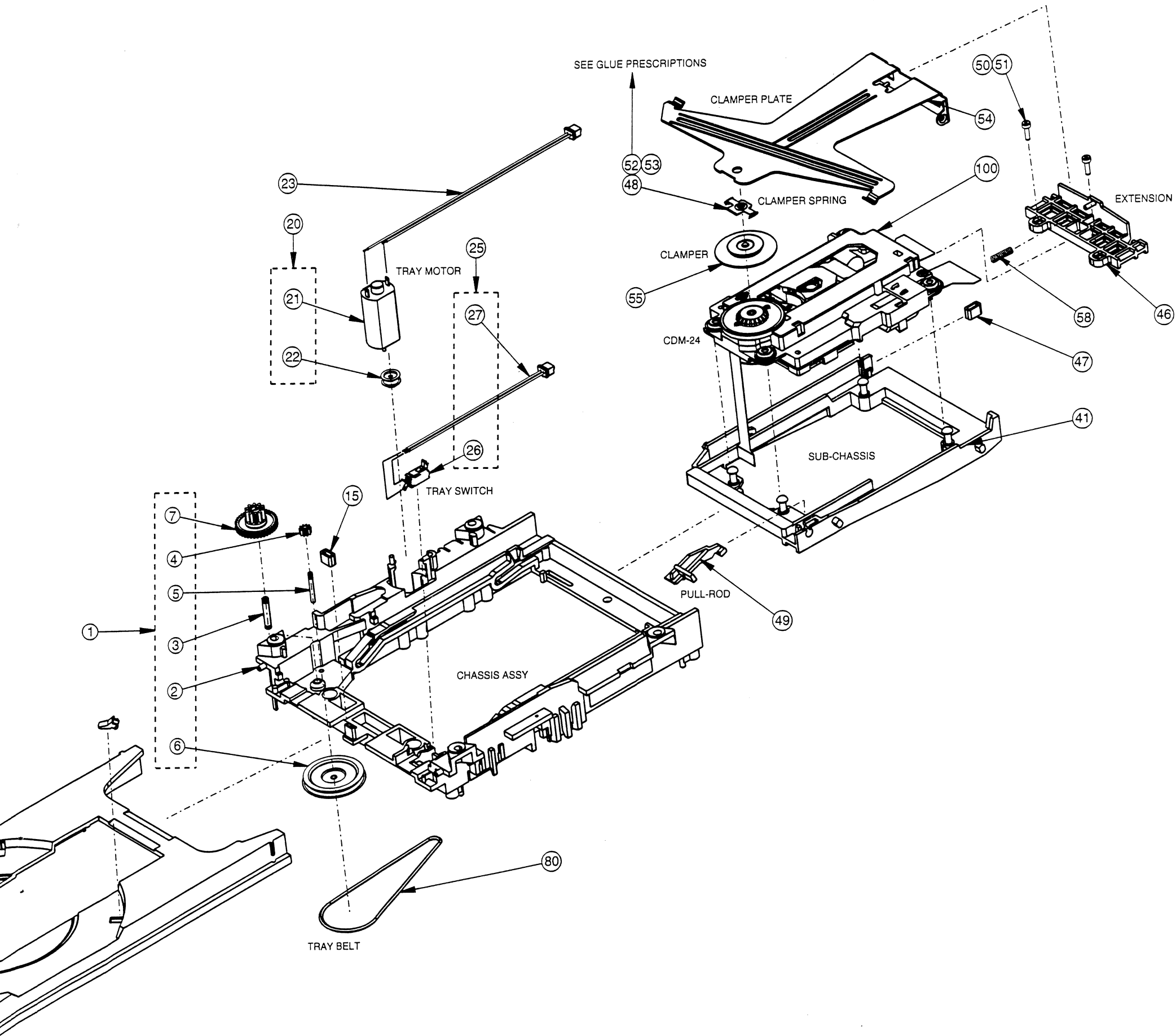

DEMOUNTING LOADER L2465

Remove the following items starting with:

- ▶ **Clamper assy spring** pos. 58 with a pair of tweezers, keep the clamper in the downward position on the turntable.
- ▶ **Clamper assy** by lifting the clamper from the turntable motor and shifting the assy to the left out of the guides on the CDM24 sub chassis assy.
- ▶ **Tray**
Pull out the tray until it sticks. Press the two locks on both sides of the chassis assy outwards. Pull out the tray.
- ▶ **Subchassis**
Shift the sub chassis pos. 41 backwards until the two rear guiding cams are in a position corresponding with the two locks on the chassis. Bend the two locks on both sides of the chassis outwards and lift out the chassis.
- ▶ **Tray motor assy**
First remove the tray motor belt.
Place the chassis on the table and bend the two locks-profiles on both sides of the tray motor compartment outwards seen from wiring side of the tray motor. Remove the tray motor.
- ▶ **Switch assy**
Hold down the locking cam below the switch and take out the switch by sliding it inwards.

MOUNTING LOADER L2465

Rebuilding the loader starting from a new (empty) chassis.

- ▶ Replace the switch-assy and the tray motor assy.
- ▶ Replace the CDM into the 4 shafts on the sub-chassis of the loader.
- ▶ Push on the grommets otherwise they will come out.
- ▶ Apply a little grease on the 4 cams on both sides of the subchassis and the corresponding slides in the chassis.
- ▶ Replace the subchassis starting with the 2 cams in front of the subchassis into the two long holes on both sides of the chassis.
- ▶ Then shift the subchassis to the front side of the chassis until the two rear cams can fall into the holes on the chassis; then push the subchassis downwards.
- ▶ Replace the pull rod, item 49.

Clamper assy

Before replacing the clamper assy a new clamper has to be mounted.
See also clamper adjustment.

- ▶ Replace the clamper by sliding the 2 holes into the cams on the subchassis of the CDM.
- ▶ Replace the clamper spring while the clamper is resting on the turntable.
- ▶ First insert the spring into the shaft on the subchassis and then by compressing the spring with the help of a pair of tweezers.
- ▶ Place the other end onto the shaft of the clamper assy.

Tray assy

Before replacing the tray, the subchassis has to be placed and hold in the most forward position so the clamper is lifted from the turntable. Then gently insert the tray into its slides.

MECHANICAL ADJUSTMENT

Clamper spring alignment procedure

Always when the motor (including the CDM mounting plate) or the clamper spring itself has to be exchanged, then the clamper spring whereto the clamper is attached has to be re-aligned. This is necessary because of the high risk for unbalance of the disc at the high rotation speed (n=4).

Procedure:

The clamper is attached to a spring. This spring is glued with a special sealing paste (called: Black Max) to the clamper hold-down assy. The clamper assy and the spring has to be replaced always by a new set (including assy and spring).

Attaching the spring to the assy:

- ▶ Replace the new assy without the spring
- ▶ Place the special tool with the spring on the turntable and glue this together
- ▶ After hardening of the glue the tool can be removed and the clamper can be placed onto its place in the clamper spring

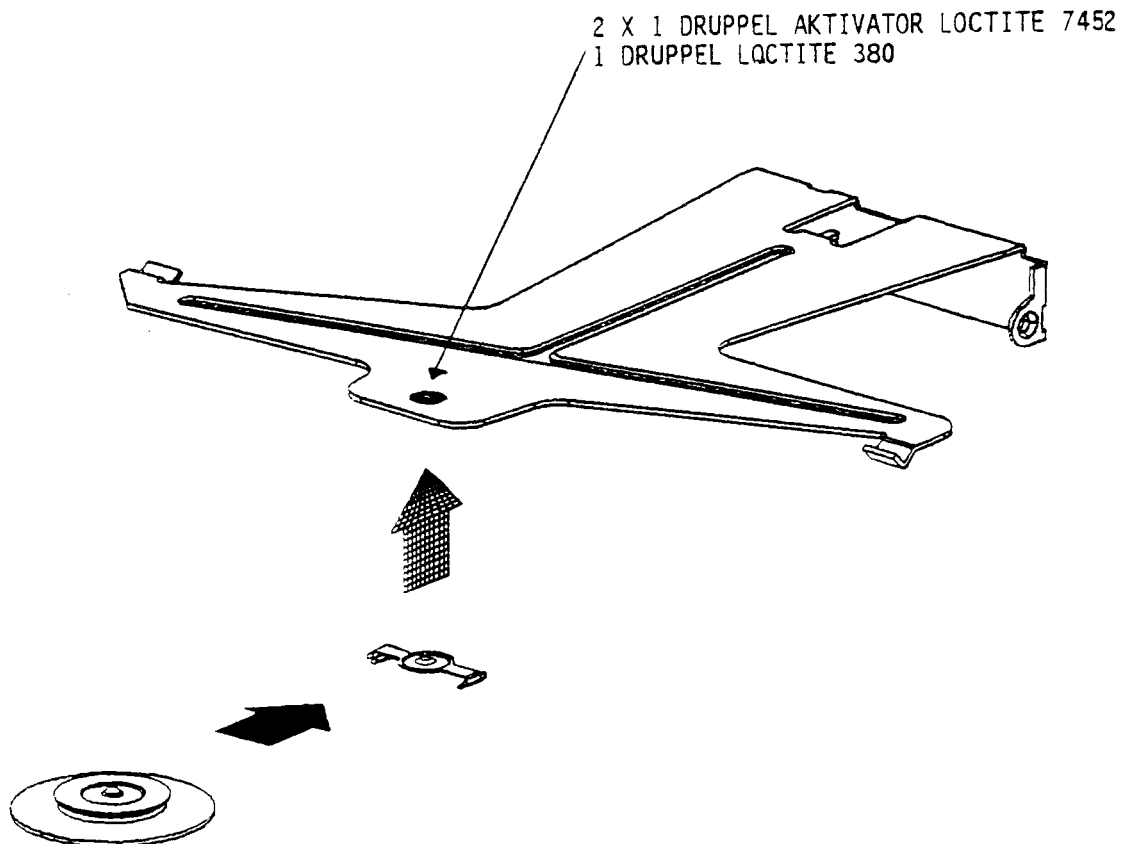

CDM24

(VERS. :VERSION, U:U.S.A., F:JAPAN, K:FAR EAST, **:EUROPE)

POS. NO	VERS. COLOR	PART NO.	DESCRIPTION
15		4822 361 21759	SLEDGE MOTOR
16		4822 492 71687	SPRING CLIP
17		4822 402 61558	SPRING CLIP
4		4822 492 71685	SPRING CLIP
5		4822 492 71685	SPRING CLIP
10		4822 522 33567	GEAR
13		4822 522 33566	GEAR RACK
14		4822 492 71684	GEAR RACK SPRING
15		4822 466 62637	SUSPENSION RUBBER
16		4822 466 62637	SUSPENSION RUBBER
17		4822 466 62637	SUSPENSION RUBBER
18		4822 466 62637	SUSPENSION RUBBER
▲ 19		4822 466 10691	FLEX FOIL CDM24 CONN
▲ 20		4822 466 10691	FLEX FOIL CDM24 CONN

【 REMARK 】

CDD2000 unit (CDR Module) and CDM-24 are not standard spare parts. The repairing of component level for those units is not allowed at local service agents also, except loader mechanical parts.

Rejected CDD2000 unit (CDR Module) should replace by Central Repair Procedure. Please contact to following MARANTZ regional office or your local MARANTZ national organization about the Central Repair Procedure.

EUROPE

MARANTZ EUROPE B.V.
P.O.BOX 80002
BUILDING SFF2
5600 JB EINDHOVEN
THE NETHERLANDS
PHONE : +31 - 40 - 2732241
FAX : +31 - 40 - 2735578

PROFESSIONAL USA

SUPERSCOPE TECHNOLOGIES, INC.
MARANTZ PROFESSIONAL PRODUCTS
1000 CORPORATE BLVD., SUITE D
AURORA, ILLINOIS 60504 USA
PHONE : 630 - 820 - 4800
FAX : 630 - 820 - 8103

JAPAN Technical

MARANTZ JAPAN INC.
35-1, 7- chome, Sagamiono
Sagamihara - shi, Kanagawa
Japan
PHONE : +81 427 44 7950
FAX : +81 427 48 0889

【 CAUTION 】

The CDM-24 for CDR620 and CDR615 is not same as a CDM-24 for PHILIPS CDD2000 (CDR-Drive equipment for computer system).

Do not use the spare part CDM-24 (Service code number 4822 691 10471) mentioned on the PHILIPS CDD2000 service manual for MARANTZ CDR620 and CDR615 even if the factory code and looks similar.

CDM24

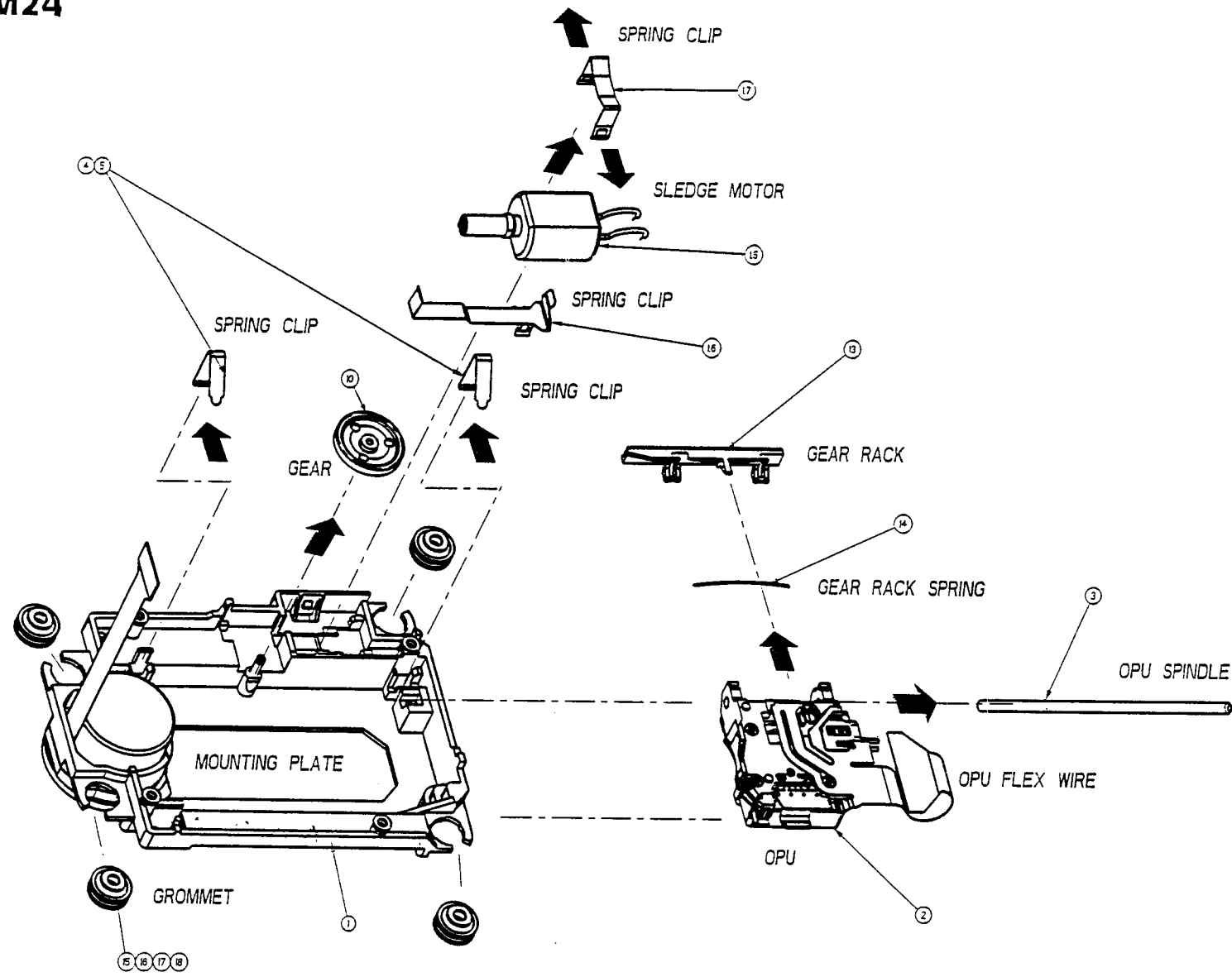

CDM24

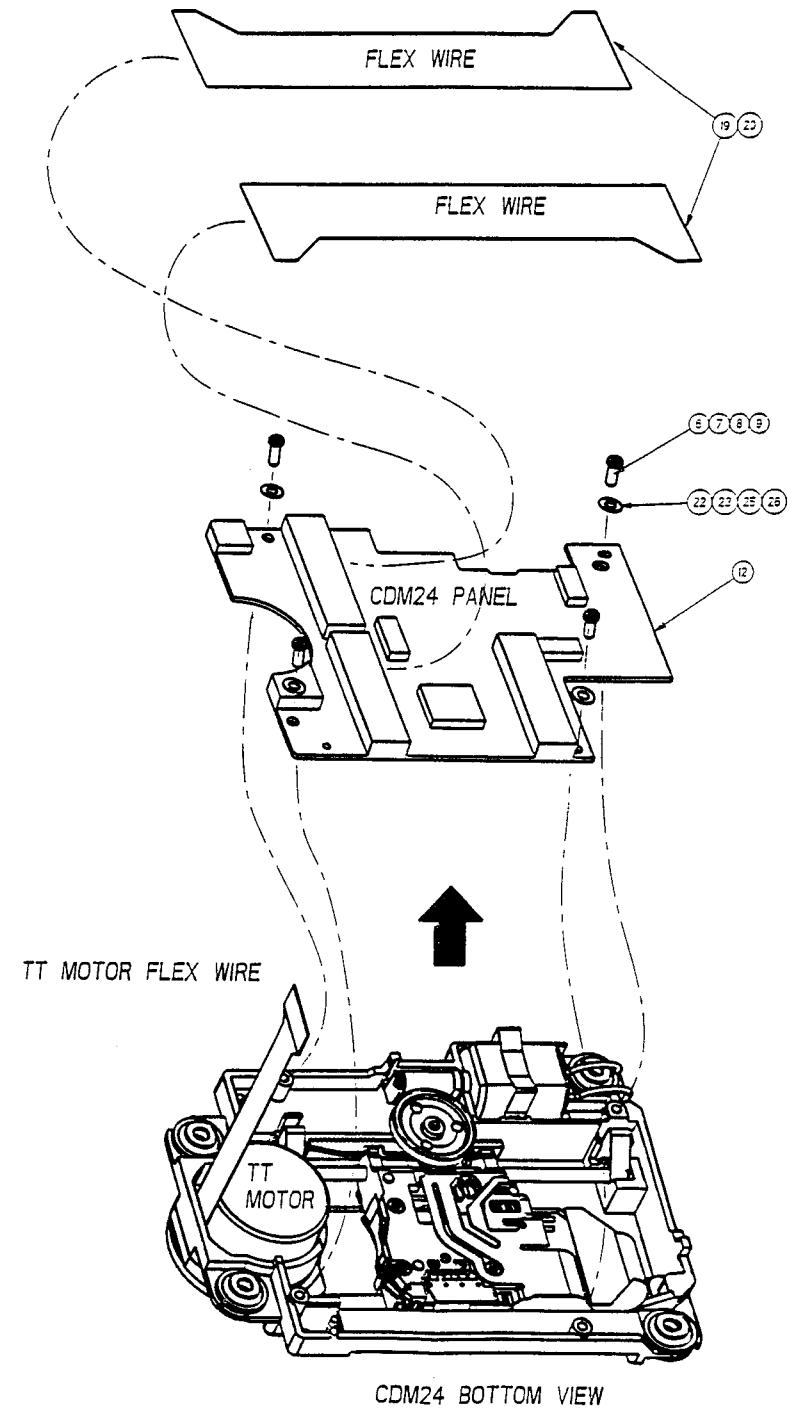

CDM24 BOTTOM VIEW

CDM24

The CDM can be removed easily by lifting of the CDM from the 4 cams on the subchassis.

Demounting CDM24

Remove the following items starting with:

CDM24 Panel (PCB)

- Desolder the sledge motor wiring.
- Remove the 4 screws on the corners of the PCB.
- Open the flex connector and remove the flex wire coming from the OPU.

Take ESD precautions by placing a clip or paperclip over the leads of the flex wire!

Sledge gear

- Turn the CDM on its back carefully. It is preferable to place the chassis on a raised area so that the turntable is free.
- Lift the gear with a pin of tweezers carefully from its shaft (replace always a new gear).
- Un-hook the spring clips from the OPU spindle from the top side.
- Turn over the CDM and remove the spring clips.
- Now the spindle with the OPU can be taken out.
- Take out the OPU spindle from the mounting plate
- Remove the gear-rack and the spring.

Sledge motor

- Un-hook the motor spring clip, this can be reached from the top-side of the mounting plate.
- Remove the clip spring which is covering the motor.
- Now the motor with the spring blade below the motor can be removed.

Mounting CDM24

Building up the CDM starting from the mounting plate with the turntable motor included (service part).

Sledge motor

- Replace sledge motor with its black-spring and the motor holding blade-spring.
- Apply also a small amount of grease to the end of the gear spindle.

OPU

- Replace the spindle and the gear-rack with its spring.
- Now the complete OPU can be replaced on the mounting plate.
- First enter the opposite side of the spindle in the mounting plate and then the whole spindle in the mounting plate.
- Replace the spindle spring clips.
- First place one end of the spring clips near the spindle and then push the other end through the holes in the mounting plate until it clicks to its place.

Gear

- Before placing the gear on its shaft bend over the gear-rack inside so the gear rack is not in touch with the gear spindle.
- After this, replace the gear while keeping the rack into its previous described position.

CDM24 panel

- Replace the panel, mount the 4 screws and the flexwire. Resolder the sledge motor wiring to the panel.

CDM sub-chassis

- Replace the subchassis with two screws to the rear side of the mounting plate.

Grommets

- Replace the 4 damping grommets into its corresponding holes on the mounting plate.

[REMARK]

CDD2000 unit (CDR Module) and CDM-24 are not standard spare parts. The repairing of component level for those units is not allowed at local service agents also, except loader mechanical parts.

Rejected CDD2000 unit (CDR Module) should replace by Central Repair Procedure. Please contact to following MARANTZ regional office or your local MARANTZ national organization about the Central Repair Procedure.

EUROPE

MARANTZ EUROPE B.V.
P.O. BOX 80002
BUILDING SFF2
5600 JB EINDHOVEN
THE NETHERLANDS
PHONE : +31 - 40 - 2732241
FAX : +31 - 40 - 2735578

PROFESSIONAL USA

SUPERSCOPE TECHNOLOGIES, INC.
MARANTZ PROFESSIONAL PRODUCTS
1000 CORPORATE BLVD., SUITE D
AURORA, ILLINOIS 60504 USA
PHONE : 630 - 820 - 4800
FAX : 630 - 820 - 8103

JAPAN Technical

MARANTZ JAPAN INC.
35-1, 7- chome, Sagamiono
Sagamihara - shi, Kanagawa
Japan
PHONE : +81 427 44 7950
FAX : +81 427 48 0889

[CAUTION]

The CDM-24 for CDR620 and CDR615 is not same as a CDM-24 for PHILIPS CDD2000 (CDR-Drive equipment for computer system).

Do not use the spare part CDM-24 (Service code number 4822 691 10471) mentioned on the PHILIPS CDD2000 service manual for MARANTZ CDR620 and CDR615 even if the factory code and looks similar.

2.5 ELECTRICAL PARTS LIST

(VERS.:VERSION, U:U.S.A., F:JAPAN, K:FAR EAST, **:EUROPE)

POS. NO	VERS. COLOR	PART NO.	DESCRIPTION
			CDM PANEL
			MISCELLANEOUS
1001		4822 267 60409	CONN 22P
1002		4822 267 60409	CONN 22P
1003		4822 267 60409	CONN 22P
1010		4822 276 13607	SWI DET 1P 0.1A/12V
			CAPACITORS
2000		4822 126 12782	100nF +80-20 Y5V 25V
2001		4822 122 33744	100pF 5% NP 50V
2002		5322 126 11579	3.3nF 10% X7R 63V
2003		5322 126 11579	3.3nF 10% X7R 63V
2004		5322 126 11583	10nF 10% X7R 63V
2005		4822 126 12782	100nF +80-20 Y5V 25V
2006		4822 126 11669	27PF
2007		4822 122 33752	15pF 5% NP 50V
2008		4822 122 33752	15pF 5% NP 50V
2009		4822 126 12779	10nF +80-20 Y5V 50V
2010		4822 126 12782	100nF +80-20 Y5V 25V
2011		4822 126 13616	390pF 10% X7R 50V
2012		4822 126 12782	100nF +80-20 Y5V 25V
2013		4822 126 12782	100nF +80-20 Y5V 25V
2014		4822 122 33744	100pF 5% NP 50V (CDR620)
2014		4822 126 13616	390pF 10% X7R 50V (CDR615)
2015			
		4822 126 12782	100nF +80-20 Y5V 25V
2019			
2020		4822 124 11463	10uF 20% 16V
2021			
		4822 126 12782	100nF +80-20 Y5V 25V
2023			
2024		4822 126 13192	2.2nF 10% X7R 63V
2025		4822 126 12782	100nF +80-20 Y5V 25V
2026		4822 126 12779	10nF +80-20 Y5V 50V
2027		4822 126 12778	1nF 10% X7R
2028		4822 126 12782	100nF +80-20 Y5V 25V
2029		4822 122 33777	47pF 5% NP 63V
2030		4822 126 12782	100nF +80-20 Y5V 25V
2031		4822 126 13617	1.8nF 10% X7R 50V (CDR620)
2031		5322 126 11579	3.3nF 10% X7R 50V (CDR615)
2032		4822 124 11445	47uF 20% 10V
2033		4822 126 12778	1nF 10% X7R
2034		4822 122 33752	15pF 5% NP 50V
2035			
		4822 126 12782	100nF +80-20 Y5V 25V
2046			
2047		4822 122 33753	150pF 5% NP 50V (CDR620)
2047		4822 122 33744	100pF 5% NP 50V (CDR615)
			RESISTORS
3001		4822 051 30183	18K 5% 0.062W
3003		4822 117 10837	100K 1% 0.1W
3004		4822 117 10837	100K 1% 0.1W
3005		4822 051 30185	1M8 5% 0.062W
3006		4822 117 10837	100K 1% 0.1W

POS. NO	VERS. COLOR	PART NO.	DESCRIPTION
3007		4822 051 30224	220K 5% 0.062W
3008		4822 051 30683	68K 5% 0.062W
3009		4822 051 30153	15K 5% 0.062W
3010		4822 051 30473	47K 5% 0.062W
3011		4822 051 30224	220K 5% 0.062W
3012		4822 051 30224	220K 5% 0.062W
3013		4822 051 30472	4K7 5% 0.062W
3014		4822 051 30122	1K2 5% 0.062W
3016		4822 051 30563	56K 5% 0.062W
3017		4822 051 30124	120K 5% 0.062W
3018		4822 051 30104	100K 5% 0.062W
3019		4822 051 30154	150K 5% 0.062W
3020		4822 051 30474	470K 5% 0.062W
3021		4822 051 30272	2K7 5% 0.062W
3022		4822 051 30104	100K 5% 0.062W
3023		4822 051 30152	1K5 5% 0.062W
3024		4822 051 30152	1K5 5% 0.062W
3028		4822 051 30391	390R 5% 0.062W
3029		4822 051 30681	680R 5% 0.062W
3030		4822 051 30104	100K 5% 0.062W
3031		4822 051 30104	100K 5% 0.062W
3032			
		4822 051 30224	220K 5% 0.062W
3034			
3036		4822 051 30224	220K 5% 0.062W
3037		4822 051 30103	10K 5% 0.062W
3038		4822 051 30153	15K 5% 0.062W
3039		4822 051 30103	10K 5% 0.062W
3041		4822 051 30473	47K 5% 0.062W (CDR620)
3041		4822 051 30333	33K 5% 0.062W (CDR615)
3042		4822 051 30103	10K 5% 0.062W
3043		4822 051 30223	22K 5% 0.062W
3045		4822 051 30222	2K2 5% 0.062W
3046		4822 051 30222	2K2 5% 0.062W
3047		4822 051 30332	3K3 5% 0.062W
3049			
		4822 051 30472	4K7 5% 0.062W
3051			
3052		4822 051 30152	1K5 5% 0.062W (CDR615 ONLY)
3053		4822 051 30472	4K7 5% 0.062W
3055		4822 051 30104	100K 5% 0.062W (CDR620)
3055		4822 051 30154	150K 5% 0.062W (CDR615)
3056		4822 051 30104	100K 5% 0.062W
3057		4822 051 30104	100K 5% 0.062W
3058		4822 051 30683	68K 5% 0.062W
3059		4822 051 30184	180K 5% 0.062W
3060		4822 051 30392	3K9 5% 0.062W (CDR620 ONLY)
3061		4822 051 30152	1K5 5% 0.062W
3062		4822 117 11746	43K RC12H1% 0.1W
3063		4822 117 11448	180R 1% 0.1W
3064		4822 051 30472	4K7 5% 0.062W
3067		4822 051 30123	12K 5% 0.062W
3068		4822 051 30472	4K7 5% 0.062W
3070		4822 051 30152	1K5 5% 0.062W
3071		4822 051 30103	10K 5% 0.062W

(VERS.:VERSION, U:U.S.A., F:JAPAN, K:FAR EAST, **:EUROPE)

POS. NO	VERS. COLOR	PART NO.	DESCRIPTION	POS. NO	VERS. COLOR	PART NO.	DESCRIPTION
3072		4822 051 30103	10K 5% 0.062W	3128		4822 051 30101	100R 5% 0.062W
3073		4822 051 30152	1K5 5% 0.062W	3129		4822 051 30103	10K 5% 0.062W (CDR620)
3074				3129		4822 051 30332	3K3 5% 0.062W (CDR615)
		4822 051 30103	10K 5% 0.062W	3130		4822 117 11503	220R 1% 0.1W
3076				3131		4822 117 11503	220R 1% 0.1W
3077		4822 051 30152	1K5 5% 0.062W	3140			
3078		4822 051 30103	10K 5% 0.062W			4822 051 30101	100R 5% 0.062W
▲ 3079		4822 117 11747	12R 1206 5% FUSE	3143			
▲ 3080		5322 117 11726	10R 5%				
3081		4822 051 30151	150R 5% 0.062W				SEMICONDUCTORS
3082		4822 051 30152	1K5 5% 0.062W	▲ 6000		5322 130 31928	BAS16
3084		4822 051 30101	100R 5% 0.062W	6001		5322 130 80214	BAS28
3085		4822 051 30272	2K7 5% 0.062W	6003		5322 130 80214	BAS28
3086		4822 051 30103	10K 5% 0.062W (CDR620 ONLY)	6004		5322 130 80214	BAS28
3087		4822 051 30104	100K 5% 0.062W	6007		5322 130 80214	BAS28
3088		4822 051 30104	100K 5% 0.062W	▲ 6011		5322 130 31928	BAS16
3089		4822 051 30184	180K 5% 0.062W	6012		5322 130 80913	BAS31
3090		4822 051 30104	100K 5% 0.062W	6014		5322 130 80214	BAS28
3091		4822 051 30151	150R 5% 0.062W	6015		5322 130 80214	BAS28 (CDR620 ONLY)
3092		4822 051 30223	22K 5% 0.062W	6016		4822 130 91482	GP2S27C
3093		4822 051 30183	18K 5% 0.062W	7001		5322 209 83125	LM324D
3094		4822 051 30183	18K 5% 0.062W	7002		5322 209 83125	LM324D
3095		4822 051 30223	22K 5% 0.062W	7003		4822 209 90331	TL084CDT
3096		4822 051 30153	15K 5% 0.062W	7004		4822 209 90331	TL084CDT
3097		4822 051 30183	18K 5% 0.062W	7005		4822 209 30426	74HC00D
3098		4822 051 30392	3K9 5% 0.062W	7006		5322 209 71564	74HC08D
3099		4822 051 30229	22R 5% 0.062W	7007		4822 209 90334	74HC173D
3100		4822 051 30271	270R 5% 0.062W	7010		4822 209 33418	TDA1372H/N1
3101		4822 051 30103	10K 5% 0.062W	7011		5322 209 11519	74HC175D
3102		4822 051 30563	56K 5% 0.062W	7012		4822 209 90332	MC79L05ABD
3103		4822 051 30333	33K 5% 0.062W	7013		4822 209 60792	74HC4053D
3104		4822 051 30271	270R 5% 0.062W	7014		5322 209 52659	ST24C02AM6
3105		4822 117 10352	33K 1% 0.2W	7016		4822 209 30351	M62352GP
3106		4822 051 30222	2K2 5% 0.062W	7100		4822 130 61207	BC848
3107		4822 051 30222	2K2 5% 0.062W	7101		4822 130 60383	BF824
3108		4822 051 30223	22K 5% 0.062W	7102		5322 130 44787	BFR31
3109		4822 051 30229	22R 5% 0.062W	7103		4822 130 61207	BC848
3111		4822 051 30391	390R 5% 0.062W (CDR620 ONLY)	7104		5322 130 60505	BCV62
3112		4822 051 30101	100R 5% 0.062W	7106		5322 130 60505	BCV62
3113				7108			
		4822 051 30103	10K 5% 0.062W			5322 130 42718	BFS20
3115				7113			
3116		4822 051 30472	4K7 5% 0.062W	7114		5322 130 44787	BFR31
3118		4822 051 30103	10K 5% 0.062W	7115		4822 130 61207	BC848
3119		4822 051 30103	10K 5% 0.062W	7116		4822 130 62748	BC858
3120		4822 051 30223	22K 5% 0.062W	7117		4822 130 61207	BC848
3121		4822 051 30122	1K2 5% 0.062W (CDR620)	7118			
3121		4822 051 30391	390R 5% 0.062W (CDR615)			4822 130 60383	BF824
▲ 3124		4822 051 10008	0R 5% 0.25W	7120			
3125		4822 051 30159	15R 5% 0.062W	7121		5322 130 41979	BC808
▲ 3126		4822 117 11747	12R 1206 5% FUSE	7122		5322 130 41979	BC808
▲ 3127		4822 117 11748	2R2 1206 5% FUSE	7123		4822 130 62748	BC858
				7124		4822 130 62748	BC858
				7127		5322 130 60504	BCV61

(VERS.:VERSION, U:U.S.A., F:JAPAN, K:FAR EAST, **:EUROPE)

POS. NO	VERS. COLOR	PART NO.	DESCRIPTION
7128		5322 130 60505	BCV62
7129		5322 130 44787	BFR31
7130		4822 130 62748	BC858
7131		4822 130 62748	BC858
7132		4822 130 60383	BF824
			CDD2000 MAIN PCB (MAIN PANEL)
			MISCELLANEOUS
▲ 1005		4822 146 10348	MAINS TRANSFORMER
1010		4822 252 51187	19398E1(0.500)
▲ 1020		4822 252 51173	19398E1(1.000)
▲ 1030		4822 252 51173	19398E1(1.000)
1101		4822 267 60409	CONN 22P
1102		4822 267 60409	CONN 22P
1143		4822 242 81546	CSTCS8.46MT-TC
1177		4822 242 10238	RESONATOR 25 MHz
1213		4822 242 10229	CRYSTAL 33.8688 MHz
1290		4822 267 51454	CONN 11P
1331		4822 276 13202	SWITCH
1343		4822 242 82075	CSTCS16.00MXC03-TC
1555		4822 242 81802	CXO-049
1570		4822 265 41515	CONN 16P
1580		4822 265 61297	CONN 50P
1600		4822 265 31274	CONN 4P
5005		4822 242 82201	DSS306-92F223Z16
5006		4822 242 82201	DSS306-92F223Z16
5016		4822 157 71659	100UH 15% 7A06L
5104		4822 157 71659	100UH 15% 7A06L
5105		4822 157 71206	BLM21A10PT
5106			
		4822 157 71658	27UH 15% 7A06L
5109			
5110		4822 157 71659	100UH 15% 7A06L
5111		4822 157 71659	100UH 15% 7A06L
5130		4822 157 71206	BLM21A10PT
5132		4822 157 71206	BLM21A10PT
5170		4822 157 71206	BLM21A10PT
5176		4822 157 71206	BLM21A10PT
5179		4822 157 71206	BLM21A10PT
5210		4822 157 71206	BLM21A10PT
5213		4822 157 70299	2U2
5223		4822 157 71206	BLM21A10PT
5245		4822 157 71206	BLM21A10PT
5255		4822 157 71206	BLM21A10PT
5275		4822 157 71206	BLM21A10PT
5276		4822 157 71206	BLM21A10PT
5330		4822 157 71206	BLM21A10PT
5375		4822 157 71206	BLM21A10PT
5380		4822 157 71206	BLM21A10PT
5385		4822 157 71206	BLM21A10PT
5390		4822 157 71206	BLM21A10PT
5400		4822 157 71206	BLM21A10PT
5403		4822 157 71206	BLM21A10PT

POS. NO	VERS. COLOR	PART NO.	DESCRIPTION
5404		4822 320 40315	SAD-025-TR (25NS)
5407		4822 157 71206	BLM21A10PT
5409		4822 157 71206	BLM21A10PT
5410		4822 157 71206	BLM21A10PT
5412			
		4822 157 71206	BLM21A10PT
5414			
5417		4822 157 71206	BLM21A10PT
5419		4822 157 71206	BLM21A10PT
5425		4822 157 71206	BLM21A10PT
5430		4822 157 71206	BLM21A10PT
5435		4822 157 71206	BLM21A10PT
5440		4822 157 71206	BLM21A10PT
5445			
		4822 157 71206	BLM21A10PT
5448			
5450		4822 157 71206	BLM21A10PT
5460		4822 157 71206	BLM21A10PT
5487			
		4822 157 71206	BLM21A10PT
5490			
▲ 5492		4822 051 20008	OR (0805)
▲ 5494			
5555			
		4822 157 71206	BLM21A10PT
5560			
5565		4822 242 82201	DSS306-92F223Z16
5580		4822 157 71206	BLM21A10PT
5591			
		4822 157 71206	BLM21A10PT
5593			
▲ 5594		4822 051 20008	OR (0805)
			CAPACITORS
2004		4822 124 41527	47uF 25V
2005		4822 124 41527	47uF 25V
2008		4822 124 41528	100uF 25V
▲ 2013		4822 122 33177	10nF 20% X7R 50V
▲ 2015		4822 122 33177	10nF 20% X7R 50V
2016		4822 124 41527	47uF 25V
2104		5322 122 32838	82nF 10% X7R 63V
▲ 2105		5322 122 32654	22nF 10% X7R 63V
2106		4822 122 33496	100nF 10% X7R 63V
2107		4822 124 80483	47uF 20% 6.3V
2108		5322 122 32838	82nF 10% X7R 63V
2109		4822 122 33325	470nF 16V
2110		4822 122 33325	470nF 16V
2111		5322 122 32838	82nF 10% X7R 63V
2112		5322 122 32838	82nF 10% X7R 63V
2113		4822 124 11353	1uF 20% 16V
2114		4822 124 11353	1uF 20% 16V
2115		4822 122 33325	470nF 16V
2116		4822 122 33325	470nF 16V
▲ 2117		5322 122 32654	22nF 10% X7R 63V

(VERS.:VERSION, U:U.S.A., F:JAPAN, K:FAR EAST, **:EUROPE)

POS. NO	VERS. COLOR	PART NO.	DESCRIPTION	POS. NO	VERS. COLOR	PART NO.	DESCRIPTION
▲ 2118		5322 122 32654	22nF 10% X7R 63V	▲ 2230		5322 122 32654	22Nf 10% X7R 63V
2119		5322 122 32838	82nF 10% X7R 63V	▲ 2231		5322 122 32654	22Nf 10% X7R 63V
▲ 2120		5322 122 32654	22nF 10% X7R 63V	2232			
▲ 2130		5322 122 32654	22nF 10% X7R 63V			4822 126 13618	330Pf 1% NPO 63V
2131		4822 124 80483	47uF 20% 6.3V	2234			
▲ 2132		5322 122 32654	22nF 10% X7R 63V	▲ 2235		5322 122 32654	22Nf 10% X7R 63V
2134				2236			
		4822 122 33575	220pF 5% NPO 50V			4822 126 13618	330Pf 1% NPO 63V
2136				2239			
2138		4822 122 33575	220pF 5% NPO 50V	▲ 2240		5322 122 32654	22Nf 10% X7R 63V
2139		4822 126 10326	180pF 5% NP 63V	2241		4822 126 13618	330Pf 1% NPO 63V
▲ 2140		5322 122 32654	22nF 10% X7R 63V	▲ 2242		5322 122 32654	22Nf 10% X7R 63V
2152		4822 122 33496	100nF 10% X7R 63V	▲ 2245		5322 122 32654	22Nf 10% X7R 63V
▲ 2155		5322 122 32654	22nF 10% X7R 63V	2246		4822 122 33496	100nF 10% X7R 63V
▲ 2156		5322 126 10223	4.7nF 10% X7R 63V	2247		4822 124 80483	47uF 20% 6.3V
▲ 2157		5322 122 32654	22nF 10% X7R 63V	▲ 2255		5322 122 32654	22Nf 10% X7R 63V
▲ 2170		5322 122 32654	22nF 10% X7R 63V	▲ 2256		5322 122 32654	22Nf 10% X7R 63V
2171		4822 124 41527	47uF 25V	2258		5322 122 32659	33Pf 5% 50V
2172				2259		5322 122 32659	33Pf 5% 50V
		4822 122 33891	3.3nF 10% X7R 63V	2262		5322 122 32659	33Pf 5% 50V
2174				2267		4822 122 33496	100nF 10% X7R 63V
▲ 2175		5322 122 34123	1nF 10% X7R 50V	2268		4822 122 33496	100nF 10% X7R 63V
2176		4822 122 33496	100nF 10% X7R 63V	▲ 2270		5322 122 32654	22nF 10% X7R 63V
2177		5322 122 32287	4.7pF 5% NP 50V	▲ 2275		5322 122 32654	22nF 10% X7R 63V
2178		5322 122 32287	4.7pF 5% NP 50V	▲ 2276		5322 122 32654	22nF 10% X7R 63V
2179		4822 122 33496	100nF 10% X7R 63V	▲ 2280		5322 122 32654	22nF 10% X7R 63V
▲ 2180				2281		5322 122 32658	22pF 5% 50V
		5322 122 32654	22nF 10% X7R 63V	▲ 2282		5322 122 32654	22nF 10% X7R 63V
▲ 2182				2283		4822 122 33496	100nF 10% X7R 63V
2183		4822 122 33496	100nF 10% X7R 63V	▲ 2284		5322 122 32654	22nF 10% X7R 63V
▲ 2184		4822 122 33177	10nF 20% X7R 50V	2285		4822 122 33496	100nF 10% X7R 63V
▲ 2193		4822 122 33177	10nF 20% X7R 50V	2286		5322 122 32658	22pF 5% 50V
▲ 2194		4822 122 33177	10nF 20% X7R 50V	2287		5322 122 32658	22pF 5% 50V
2200		4822 122 32646	5.6nF 10% X 7R 50V	2288		4822 122 31981	33nF +0.5pF 50V
▲ 2203				2292		4822 122 31981	33nF +0.5pF 50V
		5322 122 32654	22nF 10% X7R 63V	2296		4822 122 31981	33nF +0.5pF 50V
▲ 2205				2297		4822 122 33496	100nF 10% X7R 63V
2206		4822 122 32627	2.7nF 10% X7R 50V	2330		4822 122 33496	100nF 10% X7R 63V
2207		5322 126 10465	3.9nF 10% X7R 63V	▲ 2337		5322 122 34123	1nF 10% X7R 50V
2208		5322 116 80853	560pF 5% NP 63V	▲ 2375		5322 122 32654	22nF 10% X7R 63V
▲ 2209		5322 122 34123	1nF 10% X7R 50V	2380		4822 122 33496	100nF 10% X7R 63V
▲ 2210		5322 122 32654	22nF 10% X7R 63V	2385		4822 122 33496	100nF 10% X7R 63V
2211		4822 124 80483	47uF 20% 6.3V	▲ 2390		5322 122 32654	22nF 10% X7R 63V
2212		5322 122 32481	15pF 5% 50V	▲ 2400			
2213		5322 122 32481	15pF 5% 50V			5322 122 32654	22nF 10% X7R 63V
2214		5322 122 32452	47pF 5% NP 63V	▲ 2404			
▲ 2215		4822 122 33177	10nF 20% X7R 50V	2406		4822 122 33496	100nF 10% X7R 63V
▲ 2216		4822 122 33177	10nF 20% X7R 50V	▲ 2407		5322 122 32654	22nF 10% X7R 63V
▲ 2217				▲ 2409		5322 122 32654	22nF 10% X7R 63V
		5322 122 32654	22nF 10% X7R 63V	2411			
▲ 2222						4822 122 33496	100nF 10% X7R 63V
2223		4822 124 80483	47uF 20% 6.3V	2414			
2224		4822 122 33496	100nF 10% X7R 63V	2416		4822 122 33496	100nF 10% X7R 63V
2225		5322 122 32448	10pF 5% 50V	2417		4822 122 32646	5.6nF 10% X7R 50V
2226		5322 122 32448	10pF 5% 50V	2419		4822 122 33496	100nF 10% X7R 63V
▲ 2228		4822 122 33342	33nF 10% X7R 50V	2425		4822 122 33496	100nF 10% X7R 63V
▲ 2229		4822 122 33177	10nF 20% X7R 50V	2430		4822 122 33496	100nF 10% X7R 63V

(VERS.:VERSION, U:U.S.A., F:JAPAN, K:FAR EAST, **:EUROPE)

POS. NO	VERS. COLOR	PART NO.	DESCRIPTION
3238		4822 117 10833	10K 1% 0.1W
3239		4822 117 10839	130K 1% 0.1W
3240		4822 117 10839	130K 1% 0.1W
▲ 3241		4822 051 20472	4K7 5% 0.1W
3242		4822 051 20105	1M 5% 0.1W
3243		4822 051 20564	560K 5% 0.1W
3244		4822 117 11449	2K2 1% 0.1W
3245		4822 051 20223	22K 5% 0.1W
3246		4822 051 20394	390K 5% 0.1W
3247		4822 117 11503	220R 1% 0.1W
3248		4822 051 20223	22K 5% 0.1W
3249		4822 051 20223	22K 5% 0.1W
3250		4822 051 20101	100R 5% 0.1W
3251			
		4822 051 20223	22K 5% 0.1W
3253			
▲ 3254		4822 051 20472	4K7 5% 0.1W
3255		4822 051 20223	22K 5% 0.1W
3256		4822 051 20223	22K 5% 0.1W
3257		4822 051 20101	100R 5% 0.1W
3258		4822 051 20101	100R 5% 0.1W
3259		4822 117 10833	10K 1% 0.1W
3260		4822 117 11139	1K5 1% 0.1W
3261		4822 117 11449	2K2 1% 0.1W
3262		4822 051 20101	100R 5% 0.1W
3263		4822 051 20473	47K 5% 0.1W
3264			
		4822 051 10102	1K 2% 0.25W
3266			
3267		4822 117 10833	10K 1% 0.1W
3268		4822 051 20392	3K9 5% 0.1W
3269		4822 051 10102	1K 2% 0.25W
3270			
		4822 117 10833	10K 1% 0.1W
3272			
3273		4822 051 10102	1K 2% 0.25W
3274		4822 051 20183	18K 5% 0.1W
3275			
		4822 051 20223	22K 5% 0.1W
3277			
3279			
		4822 051 10102	1K 2% 0.25W
3283			
3284		4822 051 10479	47R 2% 0.25W
3285		4822 051 20562	5K6 5% 0.1W
3286		4822 051 20562	5K6 5% 0.1W
3287		4822 051 10102	1K 2% 0.25W
3288		4822 051 10102	1K 2% 0.25W
3289		4822 051 10479	47R 2% 0.25W
3290		4822 051 20562	5K6 5% 0.1W
3291		4822 051 20562	5K6 5% 0.1W
3292		4822 051 10102	1K 2% 0.25W
3293		4822 051 10102	1K 2% 0.25W

POS. NO	VERS. COLOR	PART NO.	DESCRIPTION
3294		4822 051 10479	47R 2% 0.25W
3295		4822 051 20562	5K6 5% 0.1W
3296		4822 051 20562	5K6 5% 0.1W
3297		4822 117 11503	220R 1% 0.1W
3298		4822 117 11503	220R 1% 0.1W
▲ 3310		4822 051 20472	4K7 5% 0.1W
3311		4822 117 10833	10K 1% 0.1W
3312		4822 117 11503	220R 1% 0.1W
▲ 3315		4822 051 20472	4K7 5% 0.1W
3316		4822 117 10833	10K 1% 0.1W
3317		4822 117 11503	220R 1% 0.1W
▲ 3320		4822 051 20472	4K7 5% 0.1W
3321		4822 117 10833	10K 1% 0.1W
3322		4822 117 11503	220R 1% 0.1W
3330			
		4822 117 10833	10K 1% 0.1W
3342			
3343		4822 051 20105	1M 5% 0.1W
3344		4822 051 20101	100R 5% 0.1W
3345		4822 051 20101	100R 5% 0.1W
3346			
		4822 117 10833	10K 1% 0.1W
3349			
3351			
		4822 117 10833	10K 1% 0.1W
3353			
3356			
		4822 117 10833	10K 1% 0.1W
3358			
3360			
		4822 117 10833	10K 1% 0.1W
3372			
3390		4822 117 10833	10K 1% 0.1W
▲ 3397		4822 051 20008	0R (0805)
▲ 3398		4822 051 20472	4K7 5% 0.1W (CDR620)
3398		4822 117 10833	10K 1% 0.1W (CDR615)
3403		4822 117 10833	10K 1% 0.1W
3406		4822 051 20104	100K 5% 0.1W
3411		4822 117 10833	10K 1% 0.1W
3415			
		4822 117 10833	10K 1% 0.1W
3417			
▲ 3418		4822 051 20008	0R (0805)
3422		4822 117 11449	2K2 1% 0.1W
3423			
		4822 117 10833	10K 1% 0.1W
3426			
3556		4822 051 20223	22K 5% 0.1W
3565		4822 116 40272	PTC SM 302 15V 0R25
3582		4822 117 10833	10K 1% 0.1W
▲ 3900			
		4822 051 20008	0R (0805)
▲ 3904			
▲ 3905		4822 051 10008	0R 5% 0.25W

(VERS.:VERSION, U:U.S.A., F:JAPAN, K:FAR EAST, **:EUROPE)

POS. NO	VERS. COLOR	PART NO.	DESCRIPTION	POS. NO	VERS. COLOR	PART NO.	DESCRIPTION
▲ 3906		4822 051 10008	OR 5% 0.25W	7275		4822 900 10976	CV4557A28
▲ 3908		4822 051 20008	OR (0805)	7280		4822 209 60792	74HC4053D
▲ 3910		4822 051 20008	OR (0805)	7282		4822 209 31615	LM324AD
▲ 3920		4822 051 20008	OR (0805)	7285		5322 209 61482	74HC4066D
▲ 3946		4822 051 20008	OR (0805)	▲ 7286		5322 130 41982	BC848B (UAW)
▲ 3964		4822 051 20008	OR (0805)	7287		5322 130 41983	BC858B (UAW)
▲ 3971		4822 051 20008	OR (0805)	7288		4822 130 60142	BC869
▲ 3983		4822 051 20008	OR (0805)	7289		5322 130 61569	BC868
			SEMICONDUCTORS	▲ 7290		5322 130 41982	BC848B (UAW)
6005		4822 130 81512	BZV55-C6V2	7291		5322 130 41983	BC858B (UAW)
6006		4822 130 81222	BZV55-C15	7292		4822 130 60142	BC869
▲ 6012		5322 130 31928	BAS16	7293		5322 130 61569	BC868
6013		5322 130 32076	BAT18	▲ 7294		5322 130 41982	BC848B (UAW)
6014		4822 130 33996	BZX84-C9V1	7295		5322 130 41983	BC858B (UAW)
6016		4822 130 83916	MBRS140T3	7296		4822 130 60142	BC869
6120		4822 130 80622	BAT54	7297		5322 130 61569	BC868
6140		5322 130 80214	BAS28	7305		4822 209 31275	MC34064D-5
6155		4822 130 80622	BAT54	7310		5322 130 41983	BC858B (UAW)
6185		5322 130 80214	BAS28	7315		5322 130 41983	BC858B (UAW)
6285		5322 130 80214	BAS28	7320		5322 130 41983	BC858B (UAW)
6290		5322 130 80214	BAS28	7330		4822 209 52725	MC68HC11F1-
6295		5322 130 80214	BAS28	7375		4822 209 33429	MC74ACT00D
6312		4822 130 83915	TLMV3100	7380		4822 900 10973	AM27C040-120JC
6317		4822 130 83917	TLMO3100	7385		4822 209 12712	KM6264BLG-7
6410		5322 130 80214	BAS28	7390		4822 209 33429	MC74ACT00D
▲ 6425		5322 130 31928	BAS16	7400		4822 209 52721	XILINX
6565		4822 130 83916	MBRS140T3 (CDR620 ONLY)	7403		4822 209 60792	74HC4053D
7010		4822 130 60142	BC869	▲ 7404		5322 130 41982	BC848B (UAW)
▲ 7012		5322 130 41982	BC848B (UAW)	7407		4822 209 33434	MC74F379D
▲ 7015		5322 130 41982	BC848B (UAW)	7409		4822 209 60792	74HC4053D
7105		4822 209 33419	OQ8844T/K2	7410		4822 209 52726	DSP56004FJ40
7120		5322 130 44787	BFR31	7430		4822 209 52724	UPD424400-
7121		5322 130 41983	BC858B (UAW)	7435		4822 209 52724	UPD424400-
7130		4822 209 33421	OQ8845T/K3	7440		5322 209 31276	74HCT573D
7150		4822 209 30732	LM319D	7445		4822 209 33425	CDB2
7155		5322 209 71553	NE532D	7450		4822 209 12712	KM6264BLG-7
7170		4822 209 52723	UPD784025GC-108	7460		4822 209 33291	MC74AC14DR2
7182		5322 130 41983	BC858B (UAW)	7555		4822 209 52727	SYM53CF92
7183		4822 130 60142	BC869	7565		4822 209 90333	MC34268DT (CDR615 ONLY)
7185		5322 130 61569	BC868	7585		4822 209 13644	UC5608
7192		5322 130 41983	BC858B (UAW)				
7193		4822 130 60142	BC869				
7195		5322 130 61569	BC868				
▲ 7200		5322 130 41982	BC848B (UAW)				
7205		4822 209 60792	74HC4053D				
▲ 7206		5322 130 41982	BC848B (UAW)				
▲ 7209		5322 130 41982	BC848B (UAW)				
7210		4822 209 90073	GXCT38307CB16				
7230		5322 209 61482	74HC4066D				
7235		4822 209 30095	LM833D				
7245		4822 209 33417	TDA1371H/N1				
7270		4822 209 31615	LM324AD				
▲ 7271		5322 130 41982	BC848B (UAW)				
7272		5322 130 41983	BC858B (UAW)				

Service Manual

RC620

Remote Control

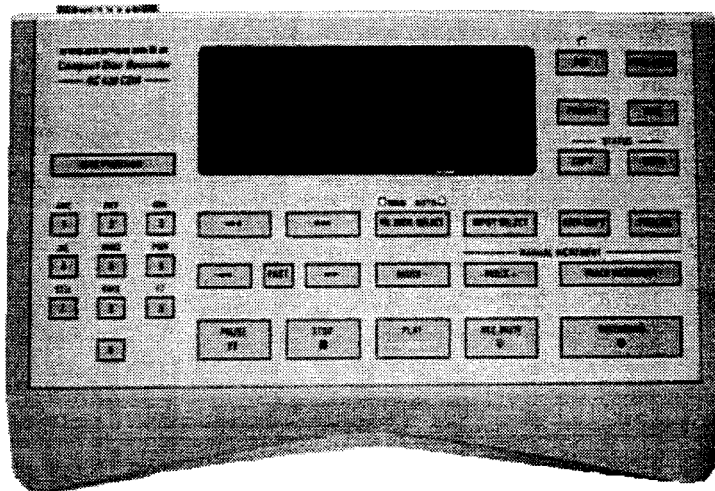
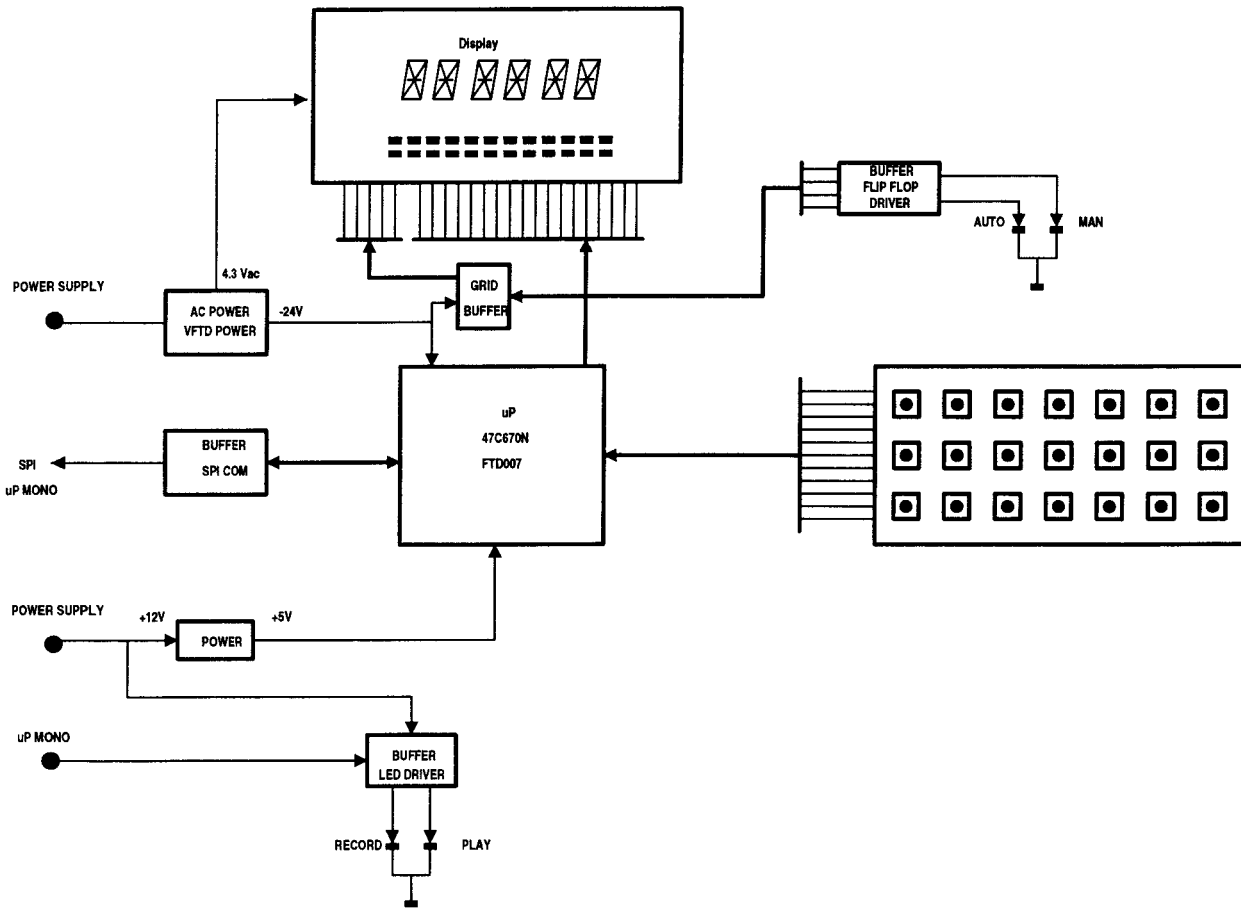

TABLE OF CONTENTS

SECTION	PAGE
3.1 BLOCK DIAGRAM	3-2
3.2 SCHEMATIC DIAGRAM AND PARTS LOCATION	
SCHEMATIC DIAGRAM	3-3
PARTS LOCATION	3-5
3.3 EXPLODED VIEW AND PARTS LIST	3-7
3.4 ELECTRICAL PARTS LIST	3-8

model RC620

3.1 BLOCK DIAGRAM



COMPONENT SIDE

1420 A1 1905 B6 1912 C2 1919 C4 1926 B1 1933 C2 2530 B6 3901 A7 3910 A3 3917 B4 3924 A6 3931 B6 3939 C4 6901 B4 6908 A1 6915 A4 6922 A3 6929 A1 7509 A1 7906 C5
1800 A5 1906 A6 1913 C4 1920 C4 1927 B2 2524 A1 2602 B5 3903 A7 3911 A3 3918 A1 3925 B4 3932 A2 3940 C4 6902 B5 6909 A1 6916 A4 6923 A3 6931 C4 7900 A4 7907 B4
1901 A7 1907 B5 1914 B7 1921 B3 1928 C1 2525 A1 2604 B5 3904 A7 3912 A2 3919 A1 3926 B4 3933 C4 3941 C5 6903 A6 6910 B1 6917 A4 6924 B7 6932 C5 7901 A5 7908 A7
1902 B6 1908 B4 1915 C7 1922 B4 1929 C1 2526 A2 2605 A6 3905 A7 3913 A2 3920 A1 3927 A6 3935 C4 3942 B4 6904 A7 6911 B1 6918 A3 6925 B7 6933 C5 7902 A4 7909 B7
1903 B7 1910 C5 1917 C5 1924 B1 1931 C1 2527 B2 2606 A5 3906 A4 3908 C4 3914 A2 3921 B5 3928 A6 3936 C4 3943 B4 6905 A6 6912 B1 6919 A3 6926 A7 6934 C5 7903 A3 7910 B2
1904 A7 1911 C3 1918 C3 1925 B1 1932 C1 2528 B6 3900 A6 3909 C5 3916 A5 3923 B6 3930 A3 3937 C4 3944 C4 6906 B6 6913 B1 6920 A3 6927 A7 7505 A2 7904 C5 7913 A7
3911 3912 3913 3914 3915 3916 3917 3918 3919 3920 3921 3922 3923 3924 3925 3926 3927 3928 3929 3930 3931 3932 3933 3934 3935 3936 3937 3938 3939 3940 3941 3942 3943 3944 3945

1 2 3 4 5 6 7

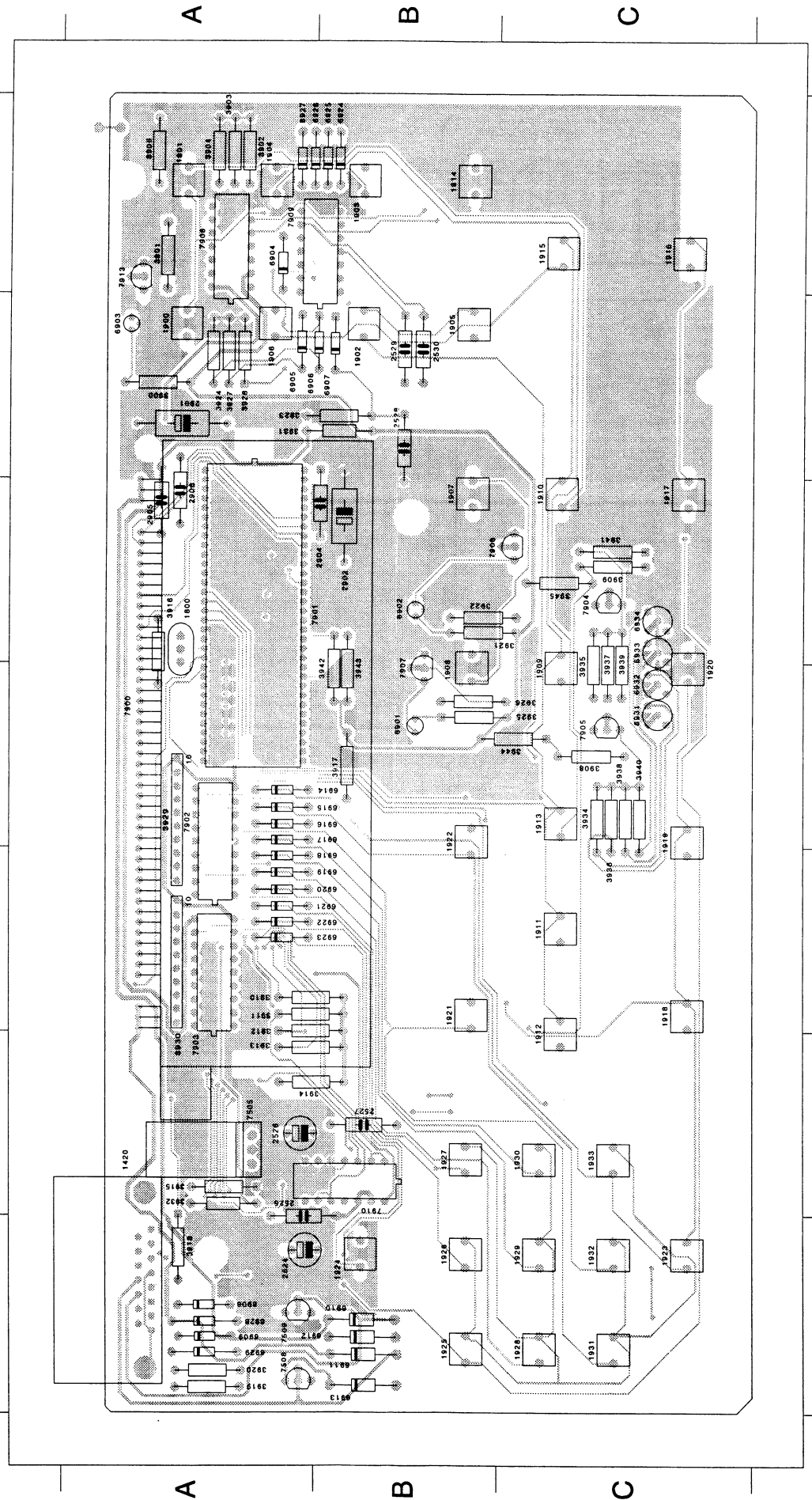

SOLDER SIDE

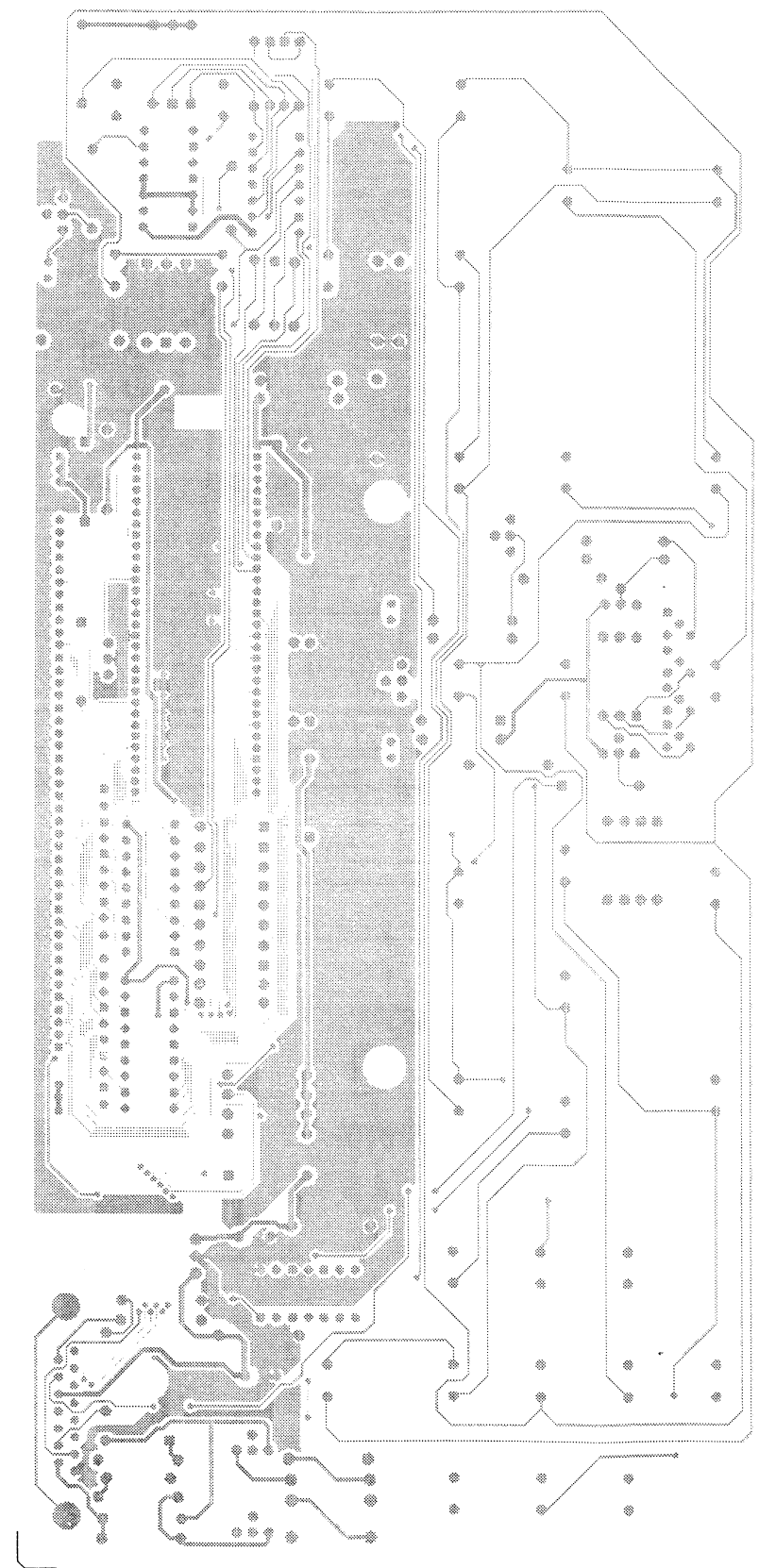

3.3 EXPLODED VIEWS AND PARTS LIST

(VERS. :VERSION, U:U.S.A., F:JAPAN, K:FAR EAST, **:EUROPE)

POS. NO	VERS. COLOR	PART NO.	DESCRIPTION
1	/09B	4822 459 04017	FRONT BLACK
1	/09M	4822 459 04102	FRONT GREY
3	/09B	4822 459 04018	FRONT ALU BLACK
3	/09M	4822 459 04103	FRONT ALU GRAY
4		4822 450 10054	WINDOW
17		4822 505 10743	M 3 HEXLOCKPASTZNB
18		4822 505 10743	M 3 HEXLOCKPASTZNB
315		4822 320 11159	FLEX 15P CONNECTOR (IVOLY)

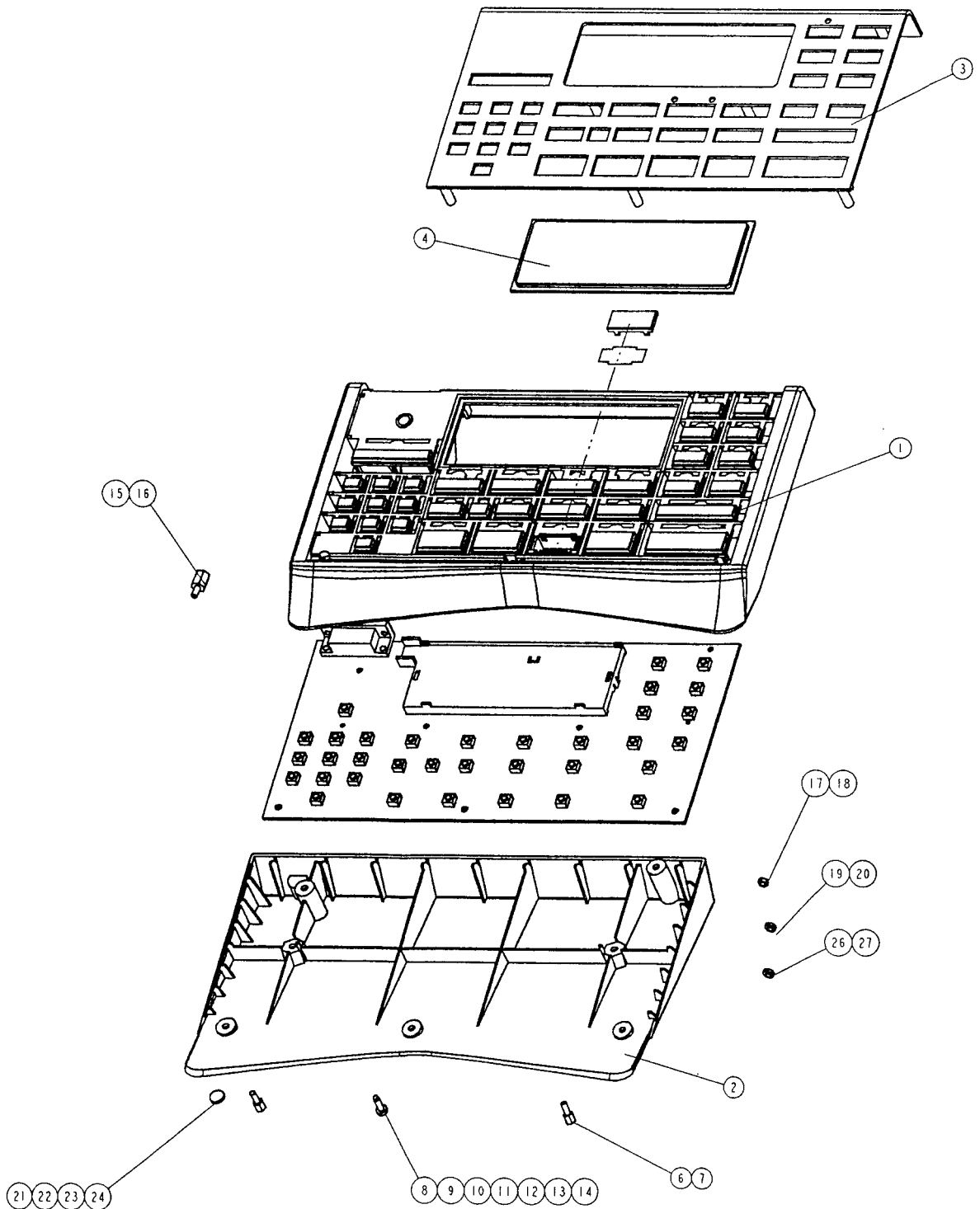

3.4 ELECTRICAL PARTS LIST

(VERS.:VERSION, U:U.S.A., F:JAPAN, K:FAR EAST, **:EUROPE)

POS. NO	VERS. COLOR	PART NO.	DESCRIPTION
MISCELLANEOUS			
1800		4822 242 81002	CST6.00MGW-TF01
1900			
		4822 276 13114	TACT SWITCH
1933			
7900		4822 135 00002	BJ379GK (DISPLAY)
CAPACITORS			
2524		4822 124 41527	47uF 25V
▲ 2525		5322 126 13187	22nF 100V
2526		4822 124 41527	47uF 25V
▲ 2527			
		5322 126 13187	22nF 100V
▲ 2530			
2901		5322 124 21643	22uF 20% 40V
2902		5322 124 21643	22uF 20% 40V
▲ 2904		5322 126 13187	22nF 100V
2905		4822 122 10177	10nF 20% 25V
2906		4822 122 10177	10nF 20% 25V
RESISTORS			
▲ 3900		4822 050 23301	330R 1% 0.6W
▲ 3901			
		4822 050 24703	47K 1% 0.6W
▲ 3905			
3908		4822 050 22202	2K2 1% 0.6W
3909		4822 050 22202	2K2 1% 0.6W
3910		4822 116 52235	1M 5% 0.5W
3911		4822 050 24302	4K3 1% 0.6W
3912		4822 050 22203	22K 1% 0.6W
3913		4822 050 22203	22K 1% 0.6W
3914		4822 050 24302	4K3 1% 0.6W
▲ 3915		4822 050 24703	47K 1% 0.6W
3916		4822 116 52235	1M 5% 0.5W
3917		4822 050 22203	22K 1% 0.6W
▲ 3918		4822 050 21002	1K 1% 0.6W
3919		4822 050 24702	4K7 1% 0.6W
3920		4822 050 24702	4K7 1% 0.6W
▲ 3921		4822 050 23301	330R 1% 0.6W
▲ 3922			
		4822 050 24703	47K 1% 0.6W
▲ 3924			
▲ 3925		4822 050 23301	330R 1% 0.6W
▲ 3926			
		4822 050 24703	47K 1% 0.6W
▲ 3928			
▲ 3929		5322 111 90473	RES.NETWORK
▲ 3930		5322 111 90473	RES.NETWORK
▲ 3931		4822 052 10478	4R7 5% 0.33W
▲ 3932		4822 052 10478	4R7 5% 0.33W
▲ 3934			
		4822 050 21001	100R 1% 0.6W
▲ 3941			
3942		4822 050 22203	22K 1% 0.6W
3943		4822 050 22203	22K 1% 0.6W
▲ 3944		4822 050 21002	1K 1% 0.6W
▲ 3945		4822 050 21002	1K 1% 0.6W

POS. NO	VERS. COLOR	PART NO.	DESCRIPTION
SEMICONDUCTORS			
6904			
		4822 130 30613	BAW62
6907			
▲ 6908		4822 130 30621	1N4148 (COL)
▲ 6909		4822 130 30621	1N4148 (COL)
▲ 6910			
		5322 130 30684	1N4002GP (UAW)
▲ 6913			
6914			
		4822 130 30613	BAW62
6927			
6928		4822 130 34278	BZX79-C6V8 (COL)
6929		4822 130 34278	BZX79-C6V8 (COL)
6901			
		4822 130 10093	GL3
6903			
6931			
		4822 130 10052	GL5ED44
6934			
7508		5322 130 44593	BC369
7509		5322 130 44593	BC369
▲ 7904		4822 130 44196	BC548C(UAW)
▲ 7905		4822 130 44196	BC548C(UAW)
7906		4822 130 44121	BC338
7907		4822 130 44121	BC338
7913		4822 130 44121	BC338
▲ 7505		4822 209 80817	L7805CV
7901		4822 209 31251	TMP47C670P-FTDD007
7902		4822 209 31623	MSL915
7903		4822 209 31623	MSL915
7908		5322 209 11109	74HCT74N
7909		5322 209 11105	74HCT00N
7910		5322 209 11265	74HCT08N