

2 SEP. 1994

31

HERDRUK

ARCHIEF			
Rec.	Doc.	Techn.	Art. Chef

SERVICE
MANUAL

CP230

marantz®

model CP230

Stereo Cassette Recorder

MARANTZ DESIGN AND SERVICE

Using superior design and selected high grade components, MARANTZ company has created the ultimate in stereo sound. Only **original MARANTZ parts** can insure that your MARANTZ product will continue to perform to the specifications for which it is famous.

Parts for your MARANTZ equipment are generally available at our National Marantz Subsidiary or Agent.

MARANTZ EUROPE B.V.
P.O. Box 80002
Building SFF 2
5600 JB Eindhoven
The Netherlands
Phone : +31-40-732241
Fax : +31-40-735578

ORDERING PARTS

Parts can be ordered either by mail or by telex. In both cases, the correct part number has to be specified. The following information must be supplied to eliminate delays in processing your order:

1. Complete address
2. Complete part numbers and quantities required
3. Description of parts
4. Model number for which the part is required
5. Way of shipment
6. Signature: any order form or telex must be signed, otherwise such part order will be considered as null and void.

ADDRESSES

AUSTRALIA
MARANTZ AUSTRALIA
Figtree Drive
Australia Centre
Homebush, NSW 2140
AUSTRALIA

FINLAND
MARANTZ
Kuortanegatan 1
00520
Helsingfors 52
Finland

ITALY
MARANTZ ITALIANA SPA
Piazza IV Novembre 3
20124 Milano
Italy

NORWAY
MARANTZ
Postboks 7034
Assiden
3007 Drammen
Norway

SPAIN
MARANTZ SPAIN
Martinez Villergas 2
Apartado 2065
Madrid 28027
Spain

AUSTRIA
MARANTZ
Hietzinger Kai 137a
1130 Wien
Austria

FRANCE
MARANTZ FRANCE
4 Rue Bernard Palissy
92600 Asnières
France

JAPAN
MARANTZ JAPAN INC.
35-1, 7-chome, Sagamiono
Sagamihara-shi, Kanagawa
Japan

PORTUGAL
COREL
Av. da Liberdade
211-2 Esq.
1200 Lisboa
Portugal

SWEDEN
MARANTZ
Box 1324
17125 Solna
Sweden

BELGIUM
MARANTZ EUROPE B.V.
Div. Benelux
P.O.Box 80002
Building SFF 2
5600 JB Eindhoven
The Netherlands

GERMANY
MARANTZ GERMANY GmbH
Kleine Heide 12
Postfach 4802
Halle-Westfalen
Germany

KUWAIT
AL ALAMIAH ELECTRONICS
P.O.Box 8196
Salmiah
22052 Kuwait

SAUDI ARABIA
AL ALAMIAH ELECTRONICS
P.O.Box 5954
University Street
Riyadh 11432
Saudi Arabia

SWITZERLAND
MARANTZ SWITZERLAND
Postfach
8010 Zürich-Müllingen
Switzerland

CHILE
MARANTZ DIVISION OF
PHILIPS S.A.
Av.Santa Maria 0760
Casilla 2687
Santiago
Chile

GREAT BRITAIN
MARANTZ HiFi UK Ltd.
Kingsbridge House
Padbury Oaks
575-583 Bath Road
Longford Middlesex UB7 OEH,
U.K.

NETHERLANDS
MARANTZ EUROPE B.V.
Div. Benelux
P.O.Box 80002
Building SFF 2
5600 JB Eindhoven
The Netherlands

SOUTH AFRICA
MARANTZ S.A.
10 Bond Street
Randburg 2194
P.O. Box 7703
Johannesburg 2000
South Africa

TRADING
MARANTZ TRADING
P.O.Box 20008
Building SFF 2
5600 JB Eindhoven
The Netherlands

DENMARK
MARANTZ
Horsvinget 5
2630 Tastrup
Denmark

GREECE
ADAMCO ELECTR. SA
P.O.Box 21025
Hippocrates Str. 188
Athens 11471
Greece

All of the above locations are fully equipped to take care of your total service needs or can advise you. Because various countries have differing configuration requirements, it is necessary that you contact the service facility in your particular country. In the event that there is no service location listed for your country, please contact the nearest facility for the necessary assistance.

In case of difficulties, do not hesitate to contact the Technical Department at above mentioned address.

TABLE OF CONTENTS

SECTION	PAGE
INTRODUCTION	1
1. P.W. BOARDS	1
2. TEST EQUIPMENT FOR SERVICING	1
3. MECHANISM AND CIRCUIT DESCRIPTION	2
3.1 Overload Protection Circuit for the Motor Drive Circuit	2
3.2 MIC AMP and Attenuator	2
3.3 Auto PLAY and Automatic Rewind Stop	2
3.4 Auto Stop	2
3.5 Pitch Control	2
4. ELECTRICAL ADJUSTMENTS	3
4.1 Head Azimuth Adjustment	3
4.2 Tape Speed Adjustment	3
4.3 Playback Equalizer Adjustment	3
4.4 Playback Level Adjustment	3
4.5 Level Meter Adjustment	4
4.6 Playback Noise Measurement	4
4.7 MPX Filter Measurement	4
4.8 Record/Playback Level Adjustment	4
4.9 Record/Playback Frequency Response Adjustment	4
4.10 Alignment Points	5
5. DIAGRAMS	6
5.1 Block/Level Diagrams	6
5.2 Chip Component Locations	7
5.3 Wiring Diagrams	8
6. EXPLODED VIEW AND PARTS LIST	10
7. ELECTRICAL PARTS LIST	16
8. TECHNICAL SPECIFICATIONS	22
9. SCHEMATIC DIAGRAM	23

MODEL CP230 STEREO CASSETTE RECORDER



INTRODUCTION

This service manual are prepared for use by Authorized Warranty Station and contains service information for Marantz Stereo Cassette Recorder.

Service information and voltage data included in this manual are intended for use by the knowledgeable and experienced technician only. All instructions should be read carefully. No attempt should be made to proceed without a good understanding of the operation of the Cassette Recorder.

The parts list furnishes information by which replacement parts may be ordered from the Marantz Company. A simple description is included for parts which can be usually obtained through local suppliers.

1. P.W. BOARDS

As can be seen from the circuit diagram, the chassis of your Cassette Recorder consists of the following units. Each unit mounted on a printed circuit board is described within the square enclosed by a bold dotted line on the circuit diagram.

1. Rec/Play Amp mounted on P.W. Board P100
2. Bias OSC mounted on P.W. Board P200
3. Mic Switch mounted on P.W. Board P300
4. L.E.D. mounted on P.W. Board P400
5. Rec/Play Sub mounted on P.W. Board P500
6. Mecha Control mounted on P.W. Board P600
7. Control Switch mounted on P.W. Board P700
8. Light mounted on P.W. Board P800
9. Mic Mode mounted on P.W. Board P900

2. TEST EQUIPMENT REQUIRED FOR SERVICING

For measuring or checking your Cassette Recorder, the following instruments and materials are necessary.

- VTVM
- Audio Oscillator (AF OSC)
- Attenuator (600 Ω)
- Oscilloscope
- Bandpass Filter (1 kHz)
- IEC A-Curve Filter
- Wow and Flutter Meter
- Torque Meter (Cassette Type)
- Digital Frequency Counter
- Distortion Meter
- Blank Tapes (Completely erased with bulk eraser)
 - TDK AC-212 (Normal)
 - TDK AC-512 (Special/CrO₂)
 - TDK AC-711 (Metal)

NOTE: If any doubt is noted in a measured value, use new tape.

- Test Tapes (New Tape)
 - MTT-111 Wow and Flutter, Tape Speed
 - MTT-112 Measurements of Output Level
 - MTT-112B Signal-to-Noise Ratio
 - MTT-150 Adjustment of Output Level
 - MTT-256 Frequency Response (for Normal)
 - MTT-356 Frequency Response (for Special/CrO₂, Fe-C₂ and Metal)
 - MTT-121 Cross Talk
 - MTT-141 Channel Separation

3. MECHANISM AND CIRCUIT DESCRIPTION

3.1 Overload Protection Circuit for the Motor Drive Circuit

Because the voltage used by the IC for the motor drive is between 3 and 5.4 volts, when the AC adaptor is used it is possible that the voltage will exceed this amount. For this reason, the overload protection circuit in Fig. 1 is used to prevent voltage overload. When V_i is below 5.5 volts, the current does not flow through the base of QM06. The signal level for the collector becomes HIGH, setting QM07 to ON and causing the current to flow to the base of QM05, also setting QM05 to ON.

The $V_i - V_{CE}$ (QM05) voltage then exits at V_o . When V_i exceeds 5.5 volts, current flows at the base of QM06, the signal level at the collector becomes LOW and QM07 shuts OFF. Current does not flow into QM05. The current is output at V_o by stabilized power constructed in QM04 and QM08. The voltage reaches approximately 4.5 volts by the voltage from QM08.

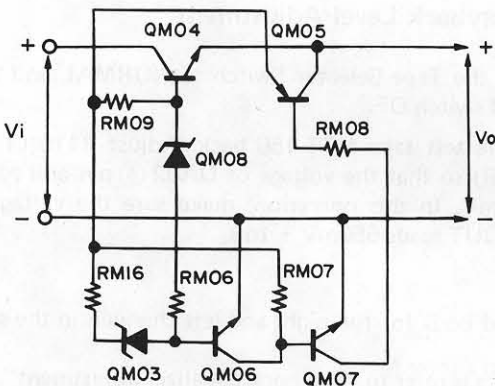
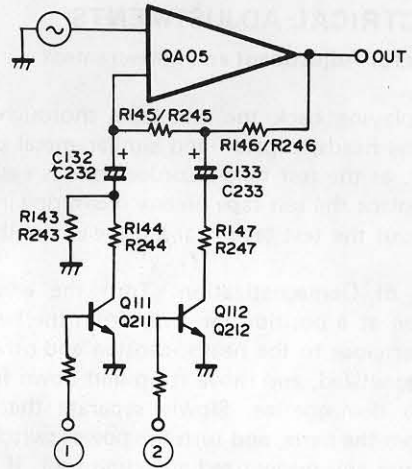

Fig. 1 Overload Protection Circuit

3.2 MIC AMP and Attenuator

The basic circuit for the mic amp is a low noise, positive-phase amplifier utilizing OP Amp. It is used in place of an attenuator to modulate the amplifier gain without the need for an attenuator between the input signal. Gain adjustment takes place inside the NF loop of the amplifier. When 0dB is occurring, a HIGH signal enters by way of ① and ② at Q111, Q211, Q112 and Q212 and maximum gain is achieved.

At -15dB the level becomes HIGH only at ① setting both Q111 and Q211 to ON, with maximum gain at -15dB. At -30dB, the level at both ① and ② simultaneously becomes LOW, with maximum gain at -30dB. With this system, compared to when the attenuator is on, the input noise is fixed and lowering of the signal-to-noise ratio, which occurs when the attenuator is ON, is prevented.



3.3 Auto PLAY and Automatic Rewind Stop

With SC03 set to ON during PLAY, the rewind button will lock when pressed. When counter reaches 999, the rewind lock releases and the PLAY operation resumes. In this condition, both CUE and REVIEW buttons do not operate and both buttons are locked. Also, when the FF button is pressed and locked in place, the lock releases when the counter reaches "900" and the PLAY mode is entered. When the tape has finished winding in both modes before the counter reaches the respective positions, the AUTO STOP function and all buttons are released. Also when the REWIND button alone is locked, the tape rewinds and rewind stops when the counter reaches "999". The same applies for fast forward operation which stops at "900". When the counter is between "900" and "999", both REWIND and FF buttons do not lock.

3.4 Auto Stop

The AUTO STOP function which detects the end of the tape is carried out by hole IC (QM20). The signal from QM20 is added to the pin ④ of QM19, while the auto stop duration is designated inside QM19. The time it takes for the auto stop function to activate after the tape stops, is determined in CM08. At this time $TE = 75 \times CM08$ (μF)mSec, while $TW = 30 \times CM07$ (μF)mSec as long as the auto stop function is operating. When it does not shut off the first time, $TE - TW - TE - TW$ is repeated until it shuts off.

3.5 Pitch Control

The pitch control is used to vary the tape speed for playback operation. During recording, it is automatically set to the RC01 center position by S105-2.

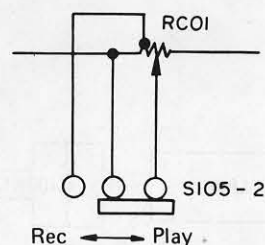

4. ELECTRICAL ADJUSTMENTS

Precautions for Adjustment and Measurement

1. Before playing back the test tape, thoroughly demagnetize the heads, capstan and similar metal parts using an eraser, as the test tape-recorded tone is easily erased.
2. Do not place the test tape on any measuring instrument.
3. Do not put the test tape near a place where the eraser is used.
4. Method of Demagnetization: Turn the eraser power switch on at a position far away from the heads. Bring the eraser close to the heads, capstan and other parts to be demagnetized, and move it up and down four or five times to demagnetize. Slowly separate the eraser far away from the parts, and turn the power switch off.
5. Do not use any magnetized adjusting tool. If necessary, demagnetize with a bulk eraser from time to time in the course of each adjustment.
6. Do not turn semi-fixed resistor or coil more than needed.
7. Measure speed and wow and flutter in the normal operating state.
8. Do not apply locking bond excessively.
9. Check the line voltage and the output of low frequency oscillator 2 – 3 times a day to see if they are set as specified.

4.1 Head Azimuth Adjustment

1. Play the test tape MTT256 back. Adjust the head azimuth adjusting screw for maximum VTVM reading.
2. If the peak levels of the left and right channels are different set the screws to obtain the mechanical center between the peaks.
3. After adjustment, repeat the playback and stop settings several times to confirm no azimuth deviation.
4. After adjustment, lock the screws with bond.

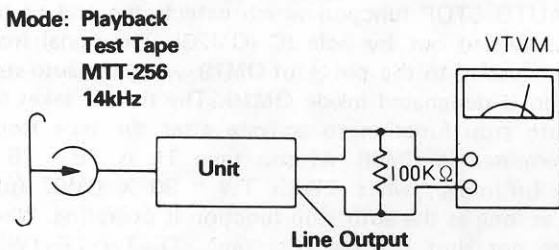

4.2 Tape Speed Adjustment

1. Play the 3kHz signal of the test tape MTT-111 back.
2. Adjust the adjusting resistor (RM05) on the P600 P.W. Board so that counter readings are between 2990 – 3010Hz.

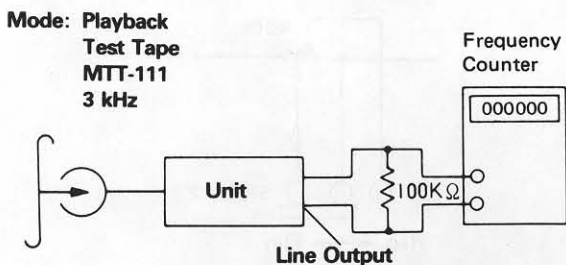

4.3 Playback Equalizer Adjustment

1. Adjust the tape selector switch to NORMAL.
2. Play the 315Hz signal of the test tape MTT-256 back. The VTVM at 0dB.
3. Play the 12.5kHz signal of the test tape back. Confirm a frequency response of 0 to 1dB in reference to the 315Hz signal level. Then, play the 12.5kHz signal back. Set the tape selector to CrO₂, Metal. Confirm the 12.5kHz signal readings at – 4.5dB, ±1dB.

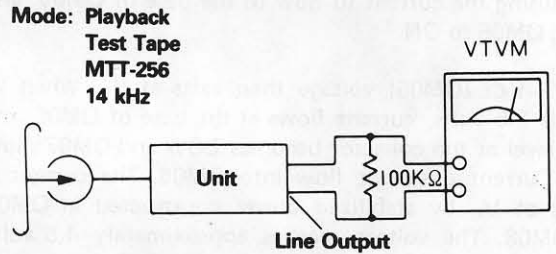

4.4 Playback Level Adjustment

1. Adjust the Tape Selector Switch to NORMAL and turn the NR switch OFF.
2. Play the test tape MTT-150 back. Adjust R110(L) and R210(R) so that the voltage of QA02 ⑥ pin and ⑳ pin is 100mV. In this operation, make sure the voltage of LINE OUT reads 550mV + 1dB.

NOTES:

1. Proceed both for the right and left channels in the same way.
2. For details refer to "Playback equalizer adjustment".

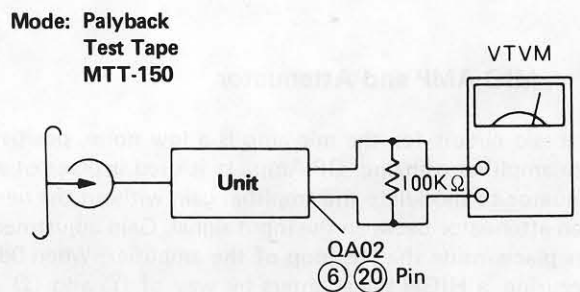

4.5 Level Meter Adjustment

1. Adjust the Tape Selector Switch to NORMAL and turn the NR switch OFF.
2. Play the test tape MTT-150 back. Adjust R128(L) and R228(R) at +3dB Level Meter reading.

4.6 Playback Noise Measurement

1. Set the selector switch to NORMAL and NR switch to OFF.
2. Play back the blank tape and make sure that the noise volume is below 2mV when the REC LEVEL Knob is set to both maximum and minimum.

NOTES:

1. Perform measurements when the power hum is at minimum.
2. Perform measurements under conditions where induction noise will not affect measurements.

4.7 MPX Filter Measurement

1. Adjust the Tape Selector Switch to NORMAL.
2. Put the blank tape in the cassette holder, and set the recording conditions. (Dolby NR "ON", MPX "ON" positions)
3. Add a 1kHz -20dB signal to LINE IN. Adjust the Rec. Volume knob to 0dB Level Meter reading.
4. Set the input signal at 19kHz \pm 10Hz. Adjust T101 (L) and T201 (R) to the minimum level.

Mode: record

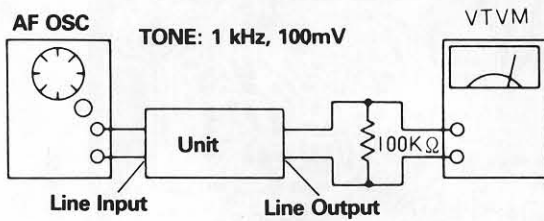

4.8 Record/Playback Level Adjustment

1. Set the tape selector switch to NORMAL.
2. Insert the AC-212 test tape in the cassette holder and set the specified recording condition (LINE OUT: 350mV).
3. Adjust R119(L) and R219(R) to the same level as the monitoring level when the tape is played back after rewinding.
4. As for CrO₂/METAL tapes, make measurements with the AC-512 and AC-711 test tapes as described above.

4.9 Record/Playback Frequency Response Adjustment

[NORMAL]

1. Set the tape selector switch to NORMAL. (with Dolby NR "ON" and MPX "OFF")

2. Insert the AC-212 test tape in the cassette holder and set the recording conditions. Attenuate from 550mV to 25dB on Line Out with the attenuator and record at 1KHz and 10KHz on an unrecorded section of the tape.
3. Rewind the tape and adjust CB01(L) and CB02(R) so that the level for 1KHz and 10KHz is brought within \pm 0.5dB for playback.
4. After making these adjustment, record and playback at 1KHz, 10KHz and 12.5KHz. Make sure results comply with the following diagram.

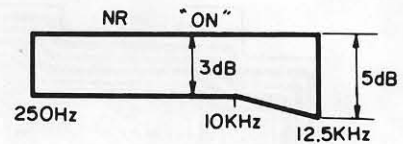
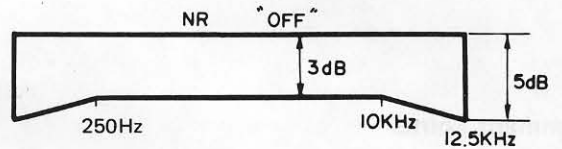

[CrO₂]

1. Set the tape selector switch to CrO₂.
2. Insert the AC-512 test tape in the cassette holder and set the recording conditions. Attenuate from 550mV to 25dB on Line Out with the attenuator and record at 1kHz, 10kHz, 12.5kHz and 15kHz on an unrecorded section of the tape.
3. Rewind the tape and adjust CB01(L) and CB02(R) so that the level for 1kHz and 10kHz is brought within \pm 0.5dB for playback.
4. After making these adjustments, record and playback at 1kHz, 10kHz, 12.5kHz and 15kHz. Make sure results comply with the following diagram.

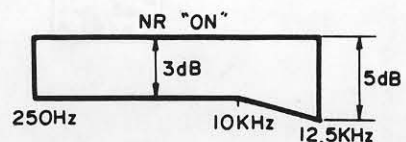
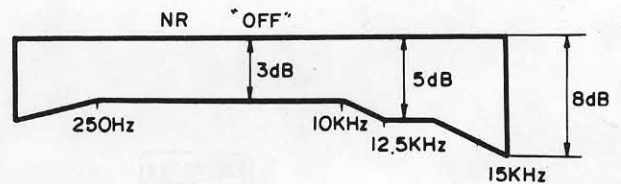

[METAL]

1. Adjust the Tape Selector Switch to METAL.
2. Load the test tape AC-711 into cassette holder. Perform measurements as with CrO₂, and make sure they conform with the Chart in right.

NOTE:

Adjustment points for NORMAL, CrO₂, METAL are common with CB01(L) and CB02(R).

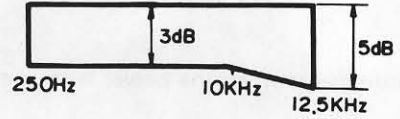
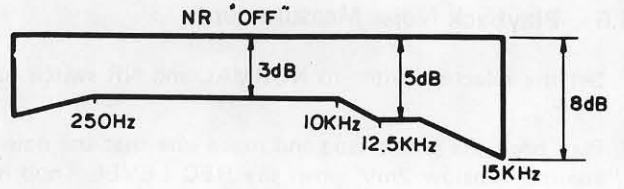

Alignment Points

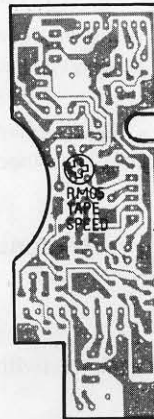
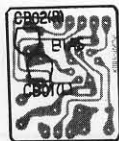
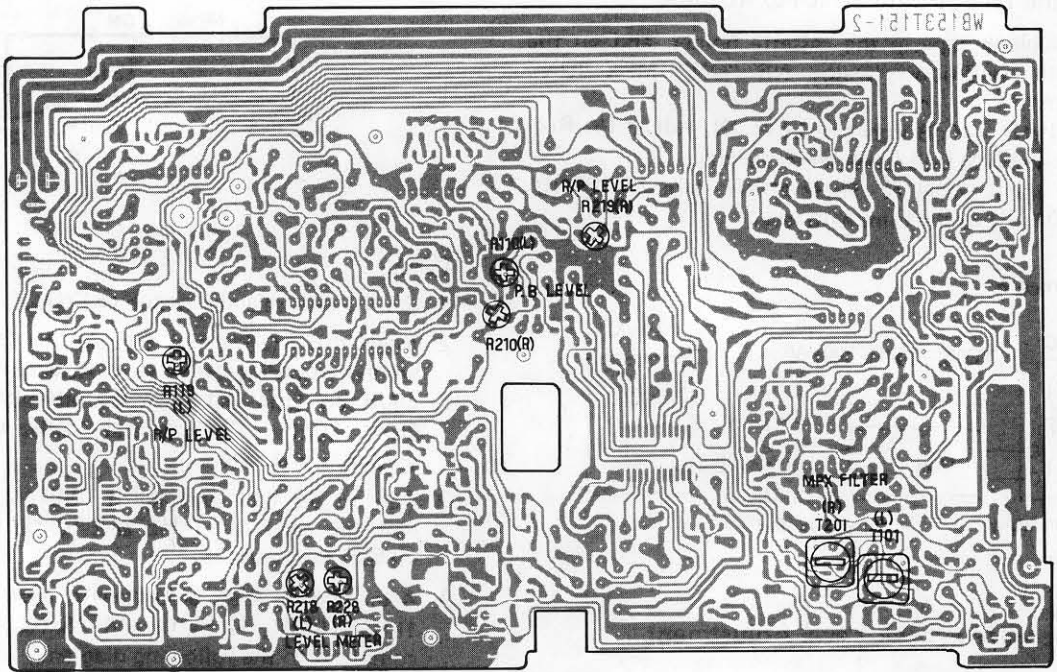

5. DIAGRAMS

5.1 Block/Level Diagrams

[RECORDING MODE]

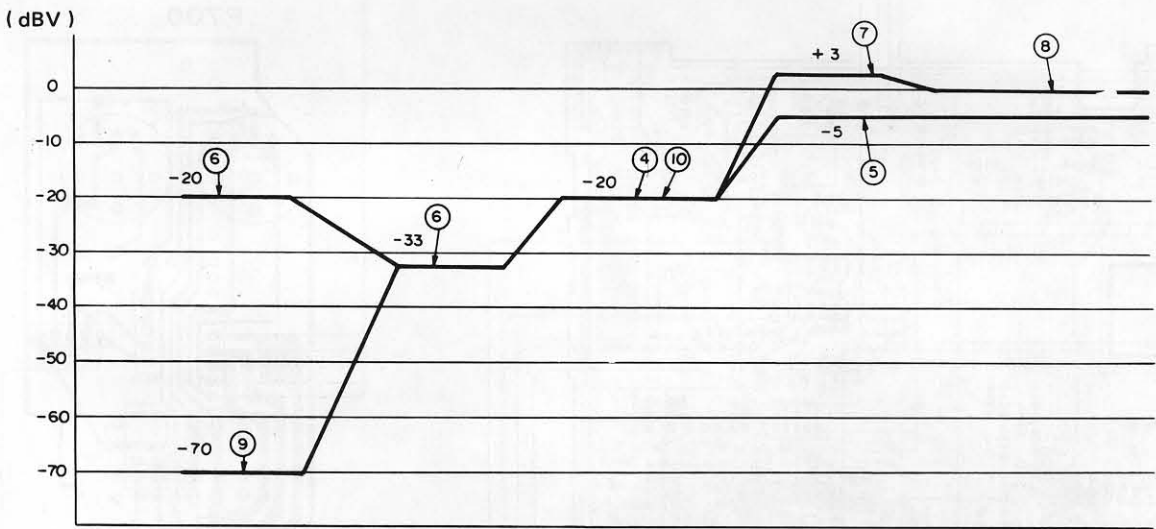
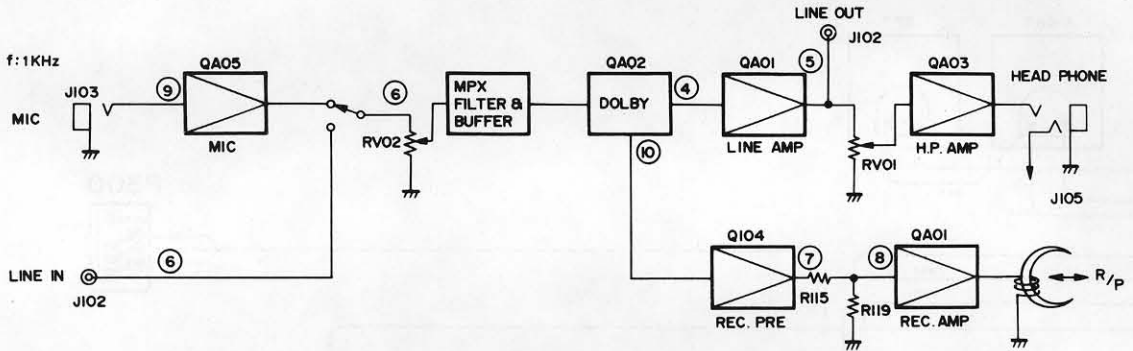

[PLAYBACK MODE]

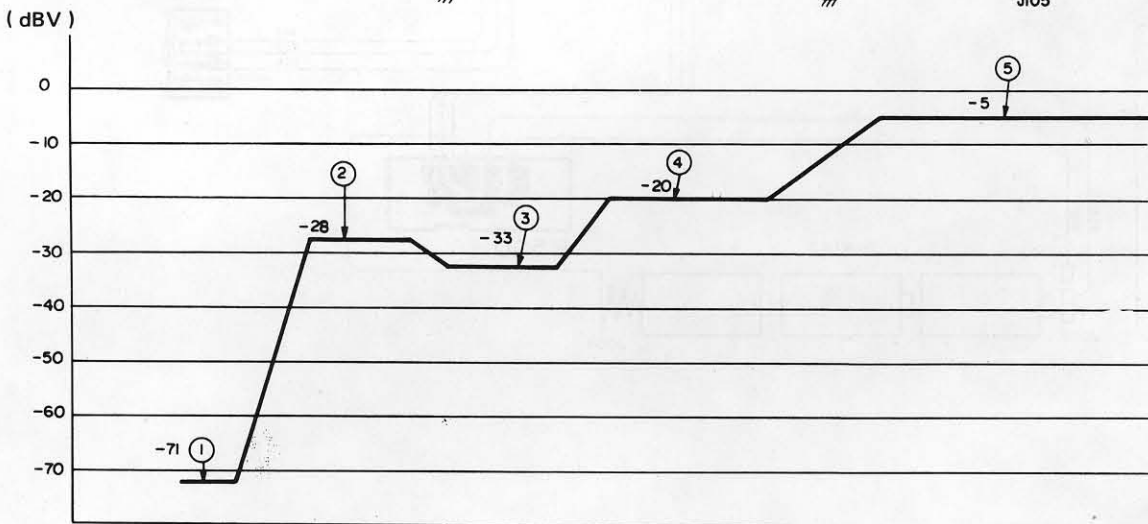
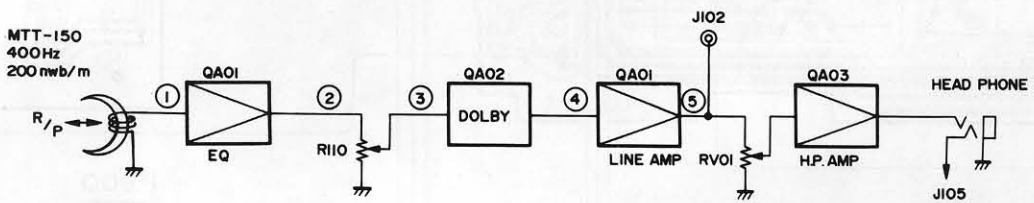

5.2 Chip Component Locations

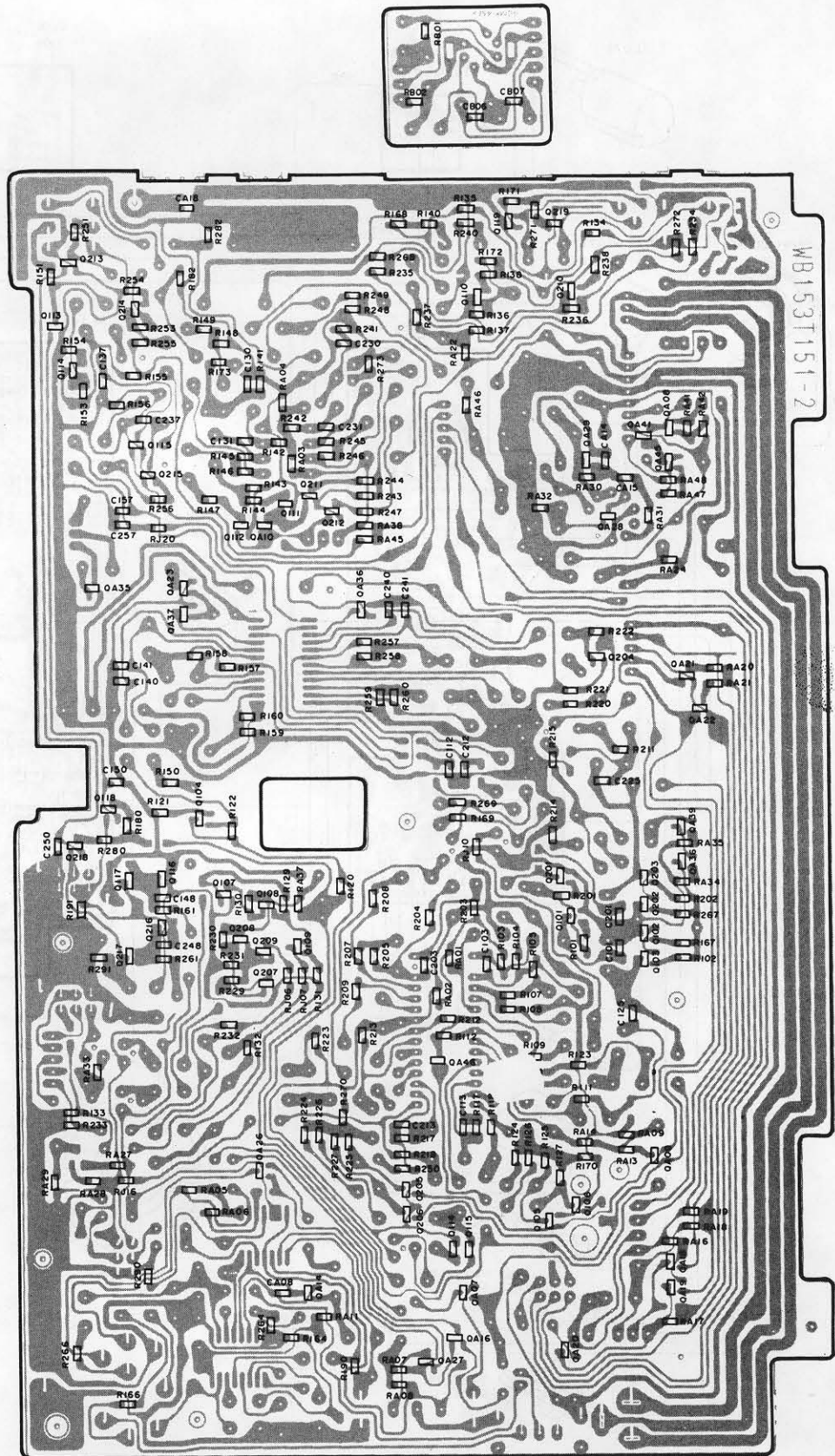

5.3 Wiring Diagram

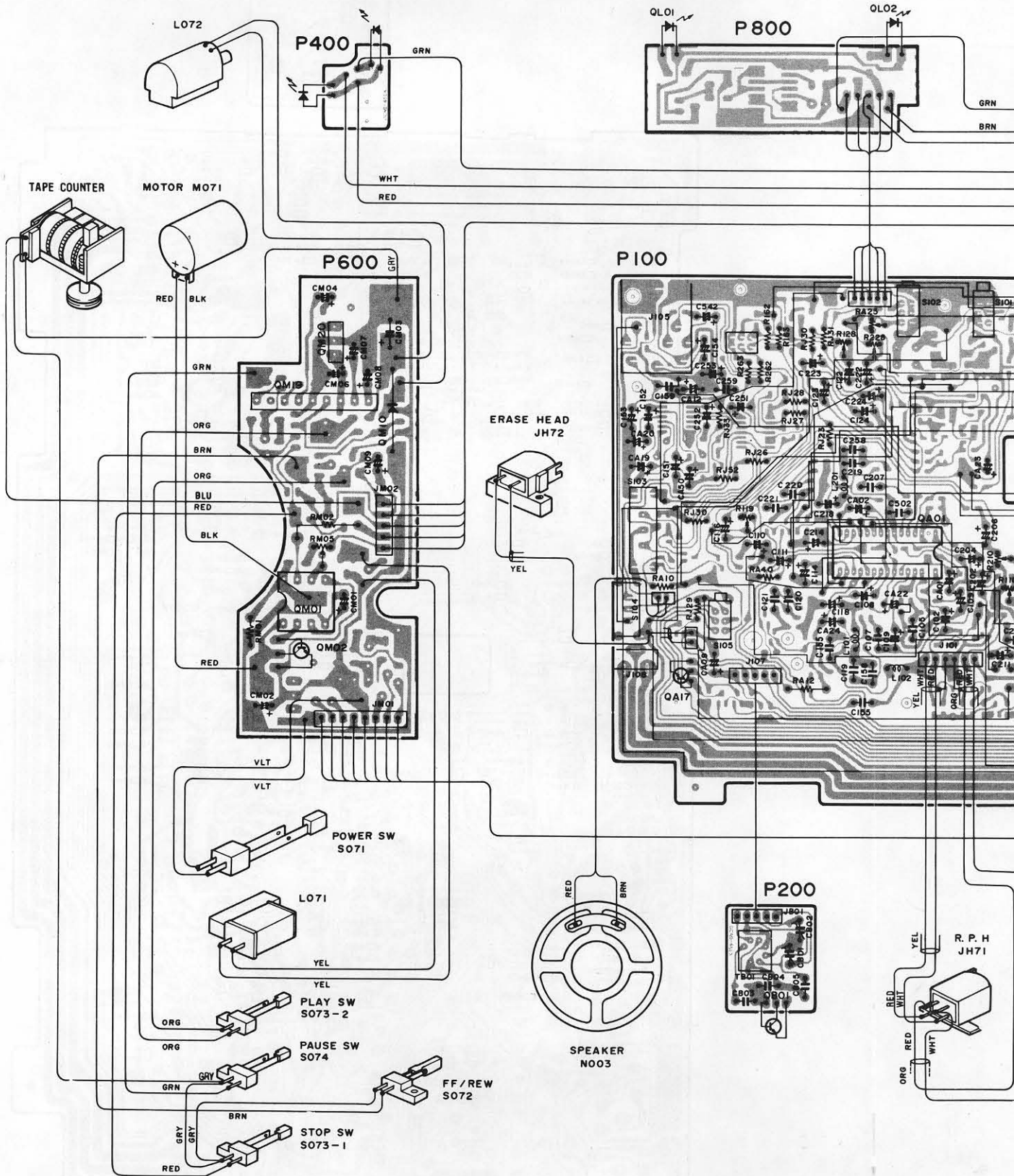

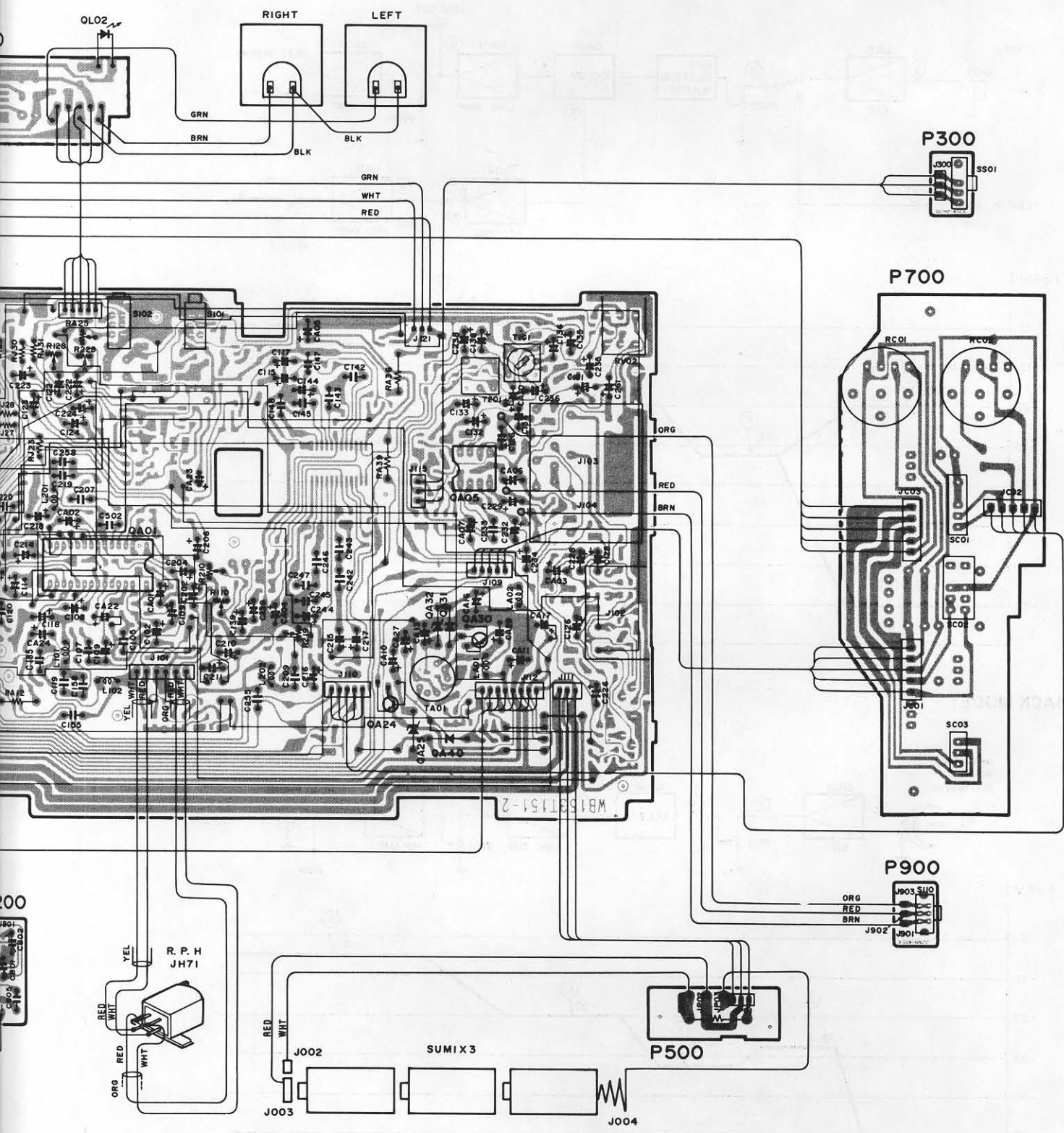

6. EXPLODED VIEW AND PARTS LIST
[C01-99] FRONT PANEL AND GENERAL PARTS

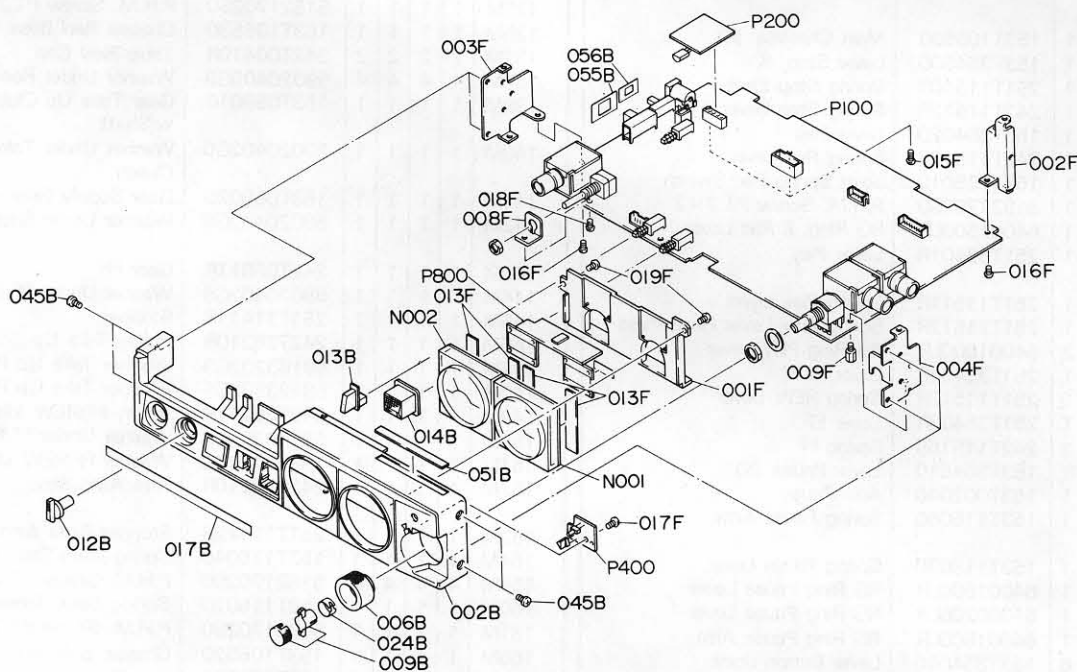

- (U):for USA
- (N):for Europe
- (A):for Australia
- (P):for PX

REF. DESIG.	Q'TY				PART NO.	DESCRIPTION
	U	N	A	P		
002B	1	1	1	1	153T064020	Case Front
006B	1	1	1	1	153T154500	Knob Rec Volume (L) (K)
009B	1	1	1	1	153T154510	Knob Rec Volume (R) (K)
012B	1	1	1	1	153T154030	Knob Monitor Volume
013B	1	1	1	1	153T154040	Knob Batt/Light
014B	1	1	1	1	153T154050	Knob Limiter
017B	1	1	1	1	153T265010	Indicator Front Case
024B	1	1	1	1	153T005010	Clamper Rec Volume (R)
045B	4	4	4	4	51102606S0	B.H.M. Screw
051B	1	1	1	1	153T251010	Badge (MARANTZ)
055B	1	1	1	1	153T303030	Mask (A)
056B	1	1	1	1	153T303040	Mask (B)
001F	1	1	1	1	153T104020	Retainer Level Meter
002F	1	1	1	1	153T160050	Bracket Top Case
003F	1	1	1	1	153T160060	Bracket Top Case (L)
004F	1	1	1	1	153T160070	Bracket Top Case (R)
008F	1	1	1	1	153T104070	Retainer P.W.B + Volume
009F	1	1	1	1	153T113010	Stud P.W.B.
013F	4	4	4	4	153T118010	Spacer
015F	2	2	2	2	51302608B0	P.H. Tapped Screw P2.6×8
016F	3	3	3	3	51572606B0	P. Tapped Screw P2.6×6
017F	1	1	1	1	51300308B0	P.H. Tapped Screw P3×8

REF. DESIG.	Q'TY				PART NO.	DESCRIPTION
	U	N	A	P		
018F	1	1	1	1	51572604B0	P. Tapped Screw P2.6×4
019F	3	3	3	3	51300306B0	P.H. Tapped Screw P3×6
N001	1	1	1	1	iM31040010	V.U. Meter Left
N002	1	1	1	1	iM31040020	V.U. Meter Right

REF. DESIG.	Q'TY	
	U	N
001B	1	1
003B	1	1
004B	1	1
005B	1	1
015B	3	3
016B	2	2
018B	1	1
019B	1	1
020B	1	1
021B	1	1
022B	1	1
023B	1	1
025B	1	1
026B	1	1
029B	1	1
030B	1	1
031B	1	1
032B	1	1
033B	1	1
036B	1	1
037B	1	1
039B	1	1
040B	2	2
041B	1	1
042B	2	2
043B	2	2
044B	4	4
047B	5	5
048B	3	3
049B	1	1

[C02-99] MAIN CASE AND GENERAL PARTS

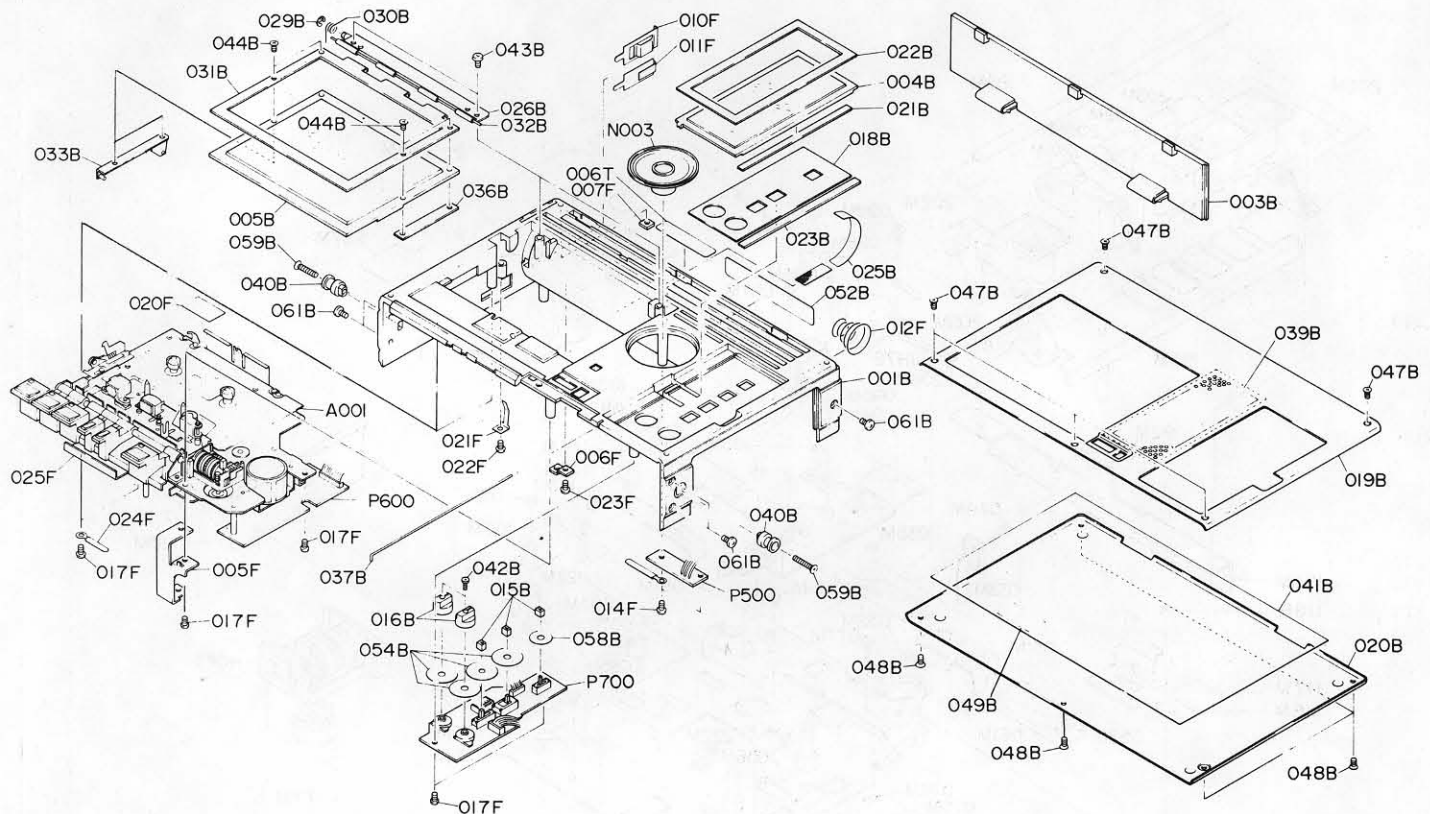

• (U):for USA • (A):for Australia
 • (N):for Europe • (P):for PX

REF. DESIG.	Q'TY				PART NO.	DESCRIPTION
	U	N	A	P		
001B	1	1	1	1	153T064010	Case Top
003B	1	1	1	1	153T257010	Lid Battery
004B	1	1	1	1	153T257020	Lid Control
005B	1	1	1	1	153T257030	Lid Cassette
015B	3	3	3	3	153T154060	Knob Slide Switch
016B	2	2	2	2	153T154070	Knob Pitch/Bias Fine
018B	1	1	1	1	153T265020	Indicator Control
019B	1	1	1	1	153T053030	Cover Top
020B	1	1	1	1	153T053020	Cover Bottom
021B	1	1	1	1	153T305010	Magnet Top Case
022B	1	1	1	1	153T063010	Escutcheon Control Cover
023B	1	1	1	1	153T060010	Clinger Control Cover
025B	1	1	1	1	153T007010	Strip
026B	1	1	1	1	153T153500	Hinge (K)
029B	1	1	1	1	64002500R0	RG Ring, E
030B	1	1	1	1	153T115090	Spring
031B	1	1	1	1	153T153020	Hinge Cassette Cover
032B	1	1	1	1	153T112380	Shaft
033B	1	1	1	1	153T104500	Retainer (K)
036B	1	1	1	1	153T104040	Retainer
037B	1	1	1	1	153T112370	Shaft Control Cover
039B	1	1	1	1	153T107010	Shaft Top Cover
040B	2	2	2	2	153T055010	Collar Top Case
041B	1	1	1	1	153T120010	Insulator Bottom Case
042B	2	2	2	2	51061704S0	P.H.M. Screw P1.7×4
043B	2	2	2	2	51302606U0	P.H.M. Screw P2.6×6
044B	4	4	4	4	51840204S0	F.H.M. Screw F2×4
047B	5	5	5	5	51842607S0	F.H.M. Screw F2.6×7
048B	3	3	3	3	51842605S0	F.H.M. Screw F2.6×5
049B	1	1	1	1	4581861010	Label

REF. DESIG.	Q'TY				PART NO.	DESCRIPTION
	U	N	A	P		
052B	1	1	1	1	153T861010	Label
054B	4	4	4	4	153T303020	Mask (A)
058B	1	1	1	1	153T303060	Mask (B)
059B	2	2	2	2	51040318S9	F.H.M. Screw F3×1.8
061B	5	5	5	5	51102606S0	B.H.M. Screw B2.6×6
005F	1	1	1	1	153T160080	Bracket Mecha + Top Case
006F	1	1	1	1	153T104050	Retainer Top Case
007F	1	1	1	1	153T104060	Retainer Top Cover
010F	1	1	1	1	153T129010	Terminal + Battery
011F	1	1	1	1	153T129020	Terminal + Battery
012F	1	1	1	1	YL11010090	Terminal - Battery
014F	1	1	1	1	51062605A0	P.H.M. Screw P2.6×5
017F	6	6	6	6	51300308B0	P.H.Tapped Screw P3×8
020F	1	1	1	1	251T274010	Reflector
021F	1	1	1	1	153T115100	Spring
022F	1	1	1	1	51300306B0	P.H.Tapped Screw P3×6
023F	2	2	2	2	51300308B0	P.H. Tapped Screw P3×8
024F	2	2	2	2	4220005030	Clamper
025F	1	1	1	1	153T303080	Mask
006T	1	1	1	1	2112265110	Indicator Serial No.
A001	1	1	1	1	153T304500	Mechahism Ass'y
N003	1	1	1	1	QK00408030	Speaker 8Ω

[P01-99] PARTS ASSEMBLED ON THE CHASSIS

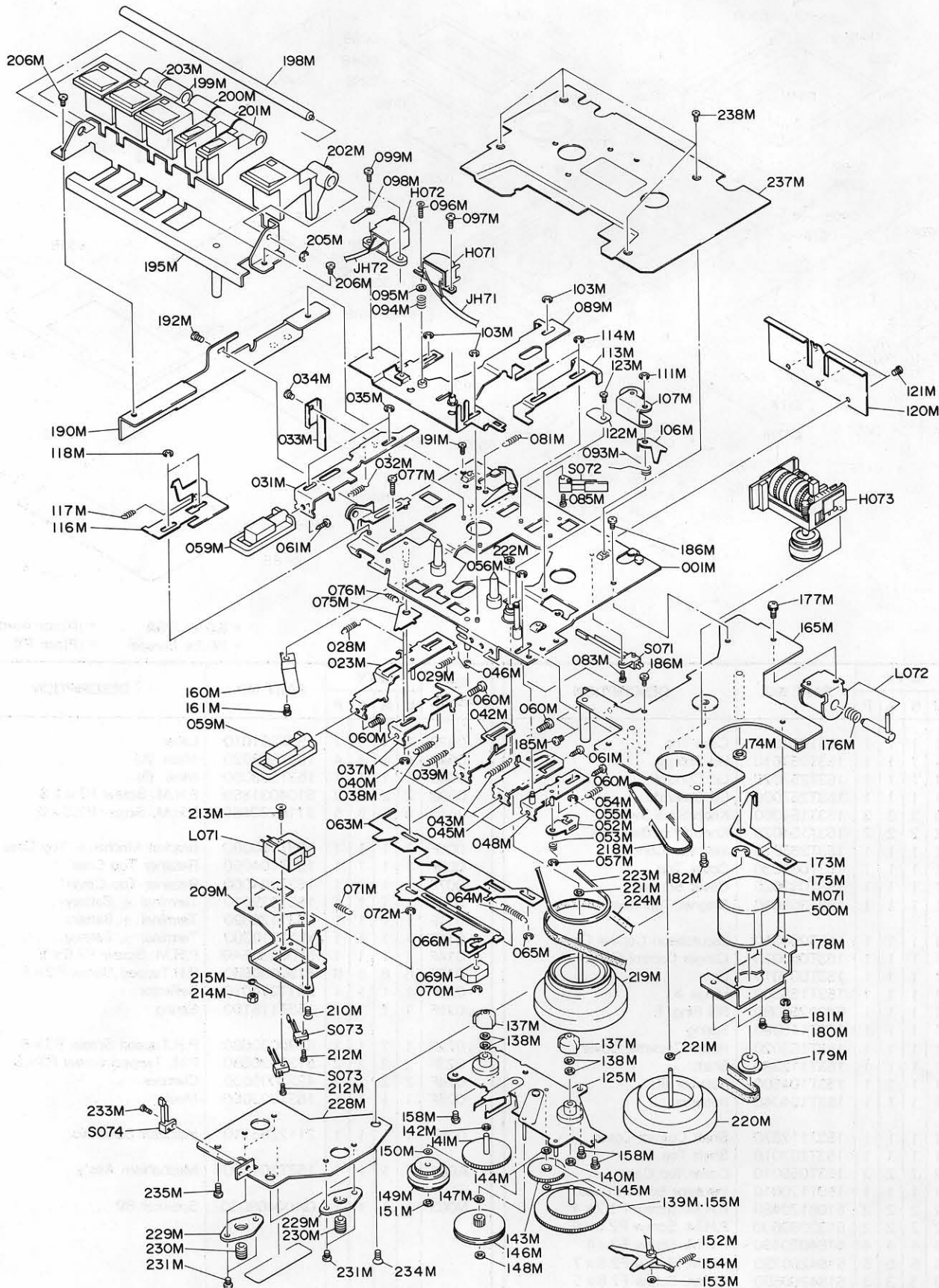

REF. DESIG.	COUNT
001M	1
023M	1
028M	1
029M	1
031M	1
032M	1
033M	1
034M	1
035M	1
037M	1
038M	1
039M	1
040M	2
042M	1
043M	1
045M	1
046M	1
048M	1
052M	1
053M	1
054M	1
055M	1
056M	1
057M	1
059M	6
060M	4
061M	2
063M	1
064M	1
065M	1
066M	1
069M	1
070M	1
071M	1
072M	1
075M	1
076M	1
077M	1
080M	1
081M	1
083M	1
085M	1
089M	1
093M	1
094M	1
095M	1
096M	1
097M	1
098M	1
099M	2
103M	3
106M	1
107M	1
111M	1
113M	1
114M	2
116M	1
117M	1
118M	2
120M	1

- (U):for USA
- (N):for Europe
- (A):for Australia
- (P):for PX

REF. DESIG.	Q'TY				PART NO.	DESCRIPTION	REF. DESIG.	Q'TY				PART NO.	DESCRIPTION
	U	N	A	P				U	N	A	P		
PARTS ASSEMBLED ON THE CHASSIS						121M	3	3	3	3	51821702S0	P.H.M. Screw P1.7×2	
001M	1	1	1	1	153T105500	Main Chassiss (K)	122M	1	1	1	251T00510R	Clamper Take Up Lever	
023M	1	1	1	1	153T354500	Lever Stop (K)	123M	1	1	1	51821702S0	P.H.M. Screw P1.7×2	
028M	1	1	1	1	251T11510R	Spring Stop Eject	125M	1	1	1	153T105530	Chassis Reel Base (K)	
029M	1	1	1	1	242T11512R	Spring Stop Lever	137M	2	2	2	242T00410R	Table Reel Cap	
031M	1	1	1	1	153T354020	Lever Rec	138M	4	4	4	59020405G9	Washer Under Reel Cap	
032M	1	1	1	1	242T11512R	Spring Rec Lever	139M	1	1	1	153T058010	Gear Take Up Clutch w/Shaft	
033M	1	1	1	1	153T125010	Joint Spring Rec Switch	140M	1	1	1	59020402G0	Washer Under Take Up Clutch	
034M	1	1	1	1	51821702S0	P.H.M. Screw P1.7×2	141M	1	1	1	153T058020	Gear Supply Gear w/Shaft	
035M	1	1	1	1	64001500LR	RG Ring, E Rec Lever	142M	1	1	1	59020402G9	Washer Under Supply	
037M	1	1	1	1	251T35401R	Lever Play	143M	1	1	1	242T05811R	Gear FF	
038M	1	1	1	1	251T11511R	Spring Play Lever	144M	1	1	1	59020402G9	Washer Under FF Gear	
039M	1	1	1	1	251T11512R	Spring Play Lever Head Plate	145M	1	1	1	251T11411R	Stopper	
040M	2	2	2	2	64001500LR	RG Ring Play Lever	146M	1	1	1	242T26210R	Pulley Take Up	
042M	1	1	1	1	251T35402R	Lever REW	147M	1	1	1	59163202G9	Washer Take Up Pulley	
043M	1	1	1	1	251T11513R	Spring REW Lever	148M	1	1	1	59123502G9	Washer Take Up Pulley	
045M	1	1	1	1	251T35403R	Lever FF	149M	1	1	1	242T26211R	Pulley FF/REW Idler	
046M	1	1	1	1	242T11516R	Spring FF	150M	1	1	1	59163202G9	Washer Under FF/REW Idler	
048M	1	1	1	1	153T354510	Lever Pause (K)	151M	1	1	1	59123202G9	Washer FF/REW Idler	
052M	1	1	1	1	153T002040	Arm Pause	152M	1	1	1	242T00210R	Arm Auto Stop	
053M	1	1	1	1	153T115060	Spring Pause Arm	153M	1	1	1	251T11412R	Stopper Auto Arm	
054M	1	1	1	1	153T115070	Spring Pause Lever	154M	1	1	1	153T115040	Spring Auto Stop Arm	
055M	1	1	1	1	64001500LR	RG Ring Pause Lever	158M	4	4	4	51821702S0	P.H.M. Screw P1.7×2	
056M	1	1	1	1	64000200LR	RG Ring Pause Lever	160M	1	1	1	153T115020	Spring Back Tension	
057M	1	1	1	1	64001500LR	RG Ring Pause Arm	161M	1	1	1	51821702S0	P.H.M. Screw P1.7×2	
059M	6	6	6	6	153T354040	Lever Button Joint	165M	1	1	1	153T105520	Chassis Sub (K)	
060M	4	4	4	4	51401705PR	B.H.Tapped Screw B1.7×5	173M	1	1	1	153T121010	Link Play Auto Stop	
061M	2	2	2	2	51381705PR	P.H.Tapped Screw P1.7×5	174M	1	1	1	59050805G9	Washer Auto Stop Link	
063M	1	1	1	1	153T054010	Cam Play/Rec Lock	175M	1	1	1	64000400LR	RG Ring	
064M	1	1	1	1	153T115150	Spring Play/Rec Lock Cam	176M	1	1	1	153T115030	Spring Solenoid Coil	
065M	1	1	1	1	64001500LR	RG Ring Play/Rec Lock Cam	177M	1	1	1	51822603S0	P.H.M. Screw P2.6×2	
066M	1	1	1	1	153T054500	Cam FF/REW Lock Cam (K)	178M	1	1	1	153T160020	Bracket Motor	
069M	1	1	1	1	251T06010R	Clinger Magnet Coil	179M	1	1	1	153T262010	Pulley Motor	
070M	1	1	1	1	64001500LR	RE Ring Clinger	180M	2	2	2	51821725SR	P.H.M. Screw P1.7×2.5	
071M	1	1	1	1	251T11514R	Spring FF/REW Lock Cam	181M	2	2	2	51442604A0	L. Washer	
072M	1	1	1	1	64000200LR	RG Ring Cam	182M	2	2	2	51302604B0	P.H. Tapped Screw P2.6×4	
075M	1	1	1	1	251T00210R	Arm Anti After Rec	185M	2	2	2	51821703S0	P.H.M. Screw P1.7×3	
076M	1	1	1	1	251T11515R	Spring Anti After Rec	186M	2	2	2	51820203S0	P.H.M. Screw P2×3	
077M	1	1	1	1	518217050R	P.H.M.Screw P1.7×5	190M	1	1	1	153T160040	Bracket Button Holder	
080M	1	1	1	1	242T11518R	Spring Cue/Rev Arm	191M	1	1	1	51820203S0	P.H.M. Screw P2×3	
081M	1	1	1	1	242T11512R	Spring Rec Safty Arm	192M	1	1	1	51821703S0	P.H.M. Screw P1.7×3	
083M	1	1	1	1	51821703S0	P.H.M. Screw P1.7×3	195M	1	1	1	153T271500	Holder Button (K)	
085M	1	1	1	1	51820235SR	P.H.M. Screw P2×3.5	198M	1	1	1	153T112130	Shaft Button	
089M	1	1	1	1	153T105510	Chassis Head Plate (K)	199M	1	1	1	153T270010	Button Stop/Eject	
093M	1	1	1	1	153T115050	Spring Pinch Roller	200M	1	1	1	153T270020	Button Play	
094M	1	1	1	1	242T11519R	Spring Azimuth	201M	2	2	2	153T270030	Button FF and REW	
095M	1	1	1	1	54020201S0	Flat Washer, P.	202M	1	1	1	153T270040	Button Pause	
096M	1	1	1	1	51100205S0	B.H.M.Screw B2×5	203M	1	1	1	153T270050	Button Rec	
097M	1	1	1	1	51100203S0	B.H.M.Screw B2×3	205M	1	1	1	64000200LR	RG Ring	
098M	1	1	1	1	251T00511R	Clamper Head Wire	206M	2	2	2	51820203S0	P.H.M. Screw P2×3	
099M	2	2	2	2	51100245S0	B.H.M.Screw B2×4.5	209M	1	1	1	153T160010	Bracket Coil and Switch Bracket	
103M	3	3	3	3	64001500LR	RG Ring Head Plate	210M	1	1	1	51040208A0	F.H.M. Screw F2×8	
106M	1	1	1	1	153T002010	Arm Pause	212M	2	2	2	51821404SR	P.H.M. Screw P1.4×4	
107M	1	1	1	1	153T255500	Pinch Roller (K)	213M	1	1	1	51041703SR	F.H.M. Screw F1.7×3	
111M	1	1	1	1	64001500LR	RG Ring	214M	1	1	1	53111703ER	Hexagon Nut	
113M	1	1	1	1	242T35416R	Lever Cue/Review Lever	215M	1	1	1	251T00511R	Clamper	
114M	2	2	2	2	64001500LR	RG Ring	218M	1	1	1	153T264020	Belt Counter	
116M	1	1	1	1	251T258010	Hook Cassette Door	219M	1	1	1	153T273010	Flywheel Main	
117M	1	1	1	1	251T11517R	Spring Hook	220M	1	1	1	153T273020	Flywheel Dummy	
118M	2	2	2	2	64001500LR	RG Ring	221M	2	2	2	59163202G9	Washer Under Flywheel	
120M	1	1	1	1	153T115010	Spring Cassette Back							

- (U):for USA
- (N):for Europe
- (A):for Australia
- (P):for PX

REF. DESIG.	Q'TY				PART NO.	DESCRIPTION
	U	N	A	P		
222M	1	1	1	1	59143502GR	Washer Oil Defence
223M	1	1	1	1	242T26412R	Belt
224M	1	1	1	1	153T264010	Belt Main
228M	1	1	1	1	153T160030	Bracket Flywheel
229M	2	2	2	2	153T104010	Retainer
230M	2	2	2	2	153T164010	Adjuster Flywheel Thrust
231M	4	4	4	4	51820203SR	P.H.M. Screw P2×3
233M	1	1	1	1	51821404SR	P.H.M. Screw P1.4×5
234M	2	2	2	2	51042604S0	F.H.M. Screw F2.6×4
235M	1	1	1	1	51442604A0	L. Washer
237M	1	1	1	1	153T053010	Cover Mecha
238M	4	4	4	4	51821702SR	P.H.M.Screw P1.7×2
500M	1	1	1	1	153T109010	Shield Motor
H071	1	1	1	1	LH42851160	Rec. Play Head
H072	1	1	1	1	LH31000570	Erase Head
H073	1	1	1	1	153T052010	Counter
L071	1	1	1	1	ME0014004R	Solenoid Coil Auto REW
L072	1	1	1	1	ME10180010	Solenoid Coil Auto Stop
M071	1	1	1	1	MM00450020	Motor
S071	1	1	1	1	SM0101097R	Switch Motor
S072	1	1	1	1	SM0101114R	Switch FF/REW
S073	2	2	2	2	SM0101115R	Switch Play and Stop
S074	1	1	1	1	SM0101115R	Switch Pause

REF. DESIG.	Q'TY				PART NO.	DESCRIPTION
	U	N	A	P		

[H01-99] PACKING MATERIALS

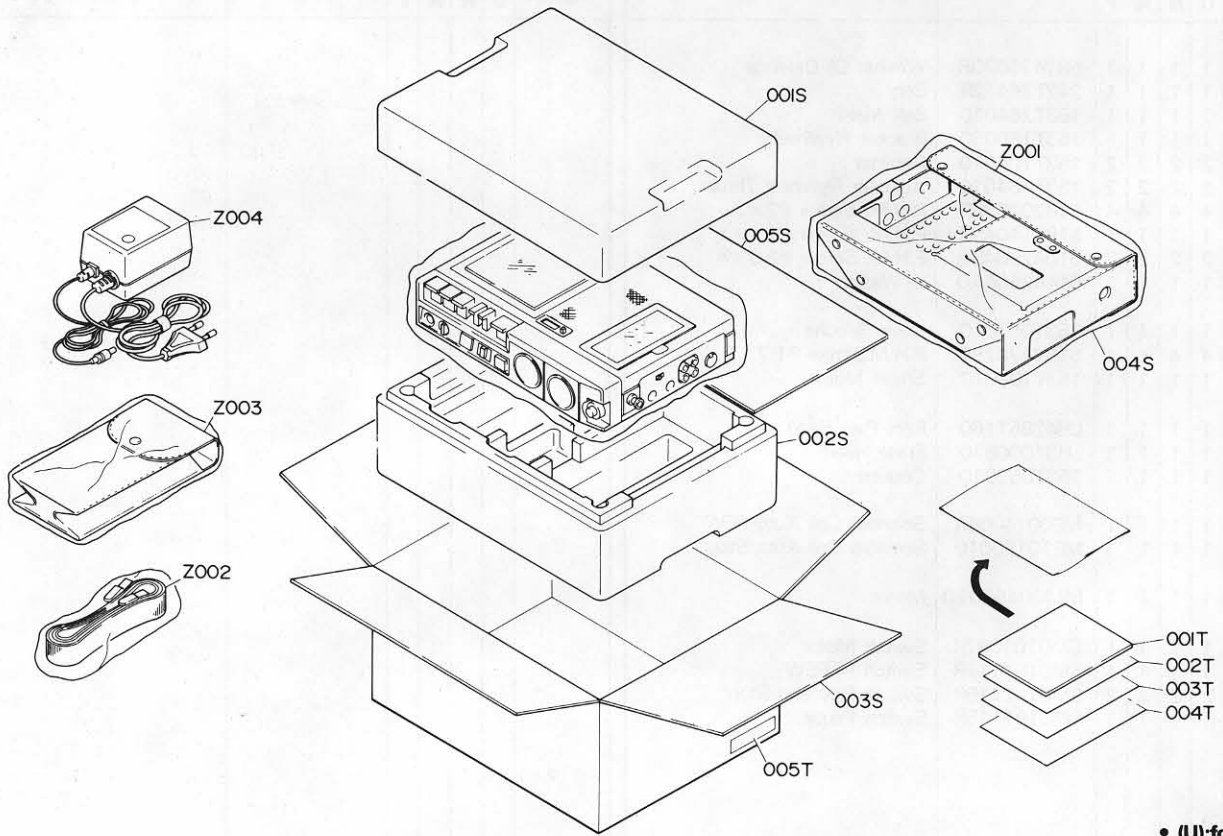

- (U):for USA
- (N):for Europe
- (A):for Australia
- (P):for PX

REF. DESIG.	Q'TY				PART NO.	DESCRIPTION
	U	N	A	P		
001S	1	1	1	1	153T809010	Cushion Top
002S	1	1	1	1	153T809020	Cushion Bottom
003S	1	1	1	1	153T801010	Packing Case
004S	1	1	1	1	9013025010	Polyethy Bag
005S	1	1	1	1	153T303010	Mask
001T	1				153T851210	User's Manual
001T		1	1	1	153T851310	User's Manual
002T	1				153T851220	User's Manual Spec Flysheet
002T		1	1	1	153T851320	User's Manual Spec Flysheet
003T	1				2818854020	Warranty Card
003T		1			153T856010	Circuit Diagram
003T			1		9631000090	Warranty Card
003T			1		416H854010	Warranty Card
004T			1		3435851210	User's Manual Flysheet
005T	2				9526019020	Serial No. Card
005T		4			9526019060	Serial No. Card
005T			4		9526019030	Serial No. Card
005T				2	9526019050	Serial No. Card

REF. DESIG.	Q'TY				PART NO.	DESCRIPTION
	U	N	A	P		
Z001	1	1	1	1	153T831010	Carrying Case
Z002	1	1	1	1	153T156010	Strap
Z003	1	1	1	1	153T831020	Carrying Case
Z004	1				AA12005010	A.C. Adaptor 4.5V 0.7A
Z004		1			AA90005010	A.C. Adaptor 4.5V 0.7A
Z004			1		AA90005020	A.C. Adaptor 4.5V 0.7A
Z004				1	AA90005030	A.C. Adaptor 4.5V 0.7A

- (U):for USA
- (N):for Europe
- (A):for Australia
- (P):for PX

7. ELECTRICAL PARTS LIST

REF. DESIG.	Q'TY				PART NO.	DESCRIPTION	REF. DESIG.	Q'TY				PART NO.	DESCRIPTION		
	U	N	A	P				U	N	A	P				
P100	1	1	1	1	WB153T1510 ZZ153T1510	P100-Rec/Play Amp Circuit Board P.W. Board Rec/Play Amp P.W. Board Assembly	C152	1	1	1	1	EJ47502510	Elect	4.7µF	25V
	1	1	1	1				C153	1	1	1				
C101	1	1	1	1	DD45471300	Ceramic	C154	1	1	1	1	EJ47600610	Elect	47µF	6.3V
C102	1	1	1	1	EJ47502510	Elect	C155	1	1	1	1	DK16102300	Ceramic	1000pF	± 10%
C103	1	1	1	1	DD45101300	Ceramic	C157	1	1	1	1	DK46102300	Ceramic	100pF	± 10%
C104	1	1	1	1	EJ10700610	Elect	C158	1	1	1	1	DF15122310	Film	1200pF	± 5%
C105	1	1	1	1	DF15273310	Film	C159	1	1	1	1	DF15224350	Film	0.22µF	± 5%
C106	1	1	1	1	EJ10505010	Elect	C161	1	1	1	1	EJ47502510	Elect	4.7µF	25V
C107	1	1	1	1	DF15223310	Film	C201	1	1	1	1	DD45471300	Ceramic	470pF	± 5%
C108	1	1	1	1	EJ10505010	Elect	C202	1	1	1	1	EJ47502510	Elect	4.7µF	25V
C109	1	1	1	1	DF15102310	Film	C203	1	1	1	1	DD45101300	Ceramic	100pF	± 5%
C110	1	1	1	1	EJ22405010	Elect	C204	1	1	1	1	EJ10700610	Elect	100µF	6.3V
C111	1	1	1	1	EJ47502510	Elect	C205	1	1	1	1	DF15273310	Film	0.027µF	± 5%
C112	1	1	1	1	DK46102300	Ceramic	C206	1	1	1	1	EJ10505010	Elect	1µF	50V
C113	1	1	1	1	DD45470300	Ceramic	C207	1	1	1	1	DF15223310	Film	0.022µF	± 5%
C114	1	1	1	1	EJ47502510	Elect	C208	1	1	1	1	EJ10505010	Elect	1µF	50V
C115	1	1	1	1	EJ47502510	Elect	C209	1	1	1	1	DF15102310	Film	1000pF	± 5%
C116	1	1	1	1	EJ47502510	Elect	C210	1	1	1	1	EJ22405010	Elect	0.22µF	50V
C117	1	1	1	1	EJ47502510	Elect	C211	1	1	1	1	EJ47502510	Elect	4.7µF	25V
C118	1	1	1	1	EJ47502510	Elect	C212	1	1	1	1	DK46102300	Ceramic	1000pF	± 10%
C119	1	1	1	1	DF15123310	Film	C213	1	1	1	1	DD45470300	Ceramic	47pF	± 5%
C120	1	1	1	1	DF15103310	Film	C214	1	1	1	1	EJ10505010	Elect	1µF	50V
C121	1	1	1	1	DF15153310	Film	C215	1	1	1	1	EJ47502510	Elect	4.7µF	25V
C122	1	1	1	1	EJ47502510	Elect	C216	1	1	1	1	EJ47502510	Elect	4.7µF	25V
C123	1	1	1	1	EJ10601610	Elect	C217	1	1	1	1	EJ47502510	Elect	4.7µF	25V
C124	1	1	1	1	EJ10601610	Elect	C218	1	1	1	1	EJ47502510	Elect	4.7µF	25V
C125	1	1	1	1	DD45101300	Ceramic	C219	1	1	1	1	DF15123310	Film	0.012µF	± 5%
C126	1	1	1	1	EJ47502510	Elect	C220	1	1	1	1	DF15103310	Film	0.01µF	± 5%
C128	1	1	1	1	EJ10505010	Elect	C221	1	1	1	1	DF15153310	Film	0.015µF	± 5%
C129	1	1	1	1	EJ47502510	Elect	C222	1	1	1	1	EJ47502510	Elect	4.7µF	25V
C130	1	1	1	1	DK46102300	Ceramic	C223	1	1	1	1	EJ10601610	Elect	10µF	16V
C131	1	1	1	1	DD45101300	Ceramic	C224	1	1	1	1	EJ10601610	Elect	10µF	16V
C132	1	1	1	1	EJ47600610	Elect	C225	1	1	1	1	DD45101300	Ceramic	100pF	± 5%
C133	1	1	1	1	EJ47600610	Elect	C226	1	1	1	1	EJ47502510	Elect	4.7µF	25V
C134	1	1	1	1	EJ47502510	Elect	C228	1	1	1	1	EJ10505010	Elect	1µF	50V
C135	1	1	1	1	EJ47502510	Elect	C229	1	1	1	1	EJ47502510	Elect	4.7µF	25V
C136	1	1	1	1	EJ47502510	Elect	C230	1	1	1	1	DK46102300	Ceramic	1000pF	± 10%
C137	1	1	1	1	DK46562300	Ceramic	C231	1	1	1	1	DD45101300	Ceramic	1000pF	± 5%
C138	1	1	1	1	EJ47502510	Elect	C232	1	1	1	1	EJ47600610	Elect	47µF	6.3V
C139	1	1	1	1	EJ47502510	Elect	C233	1	1	1	1	EJ47600610	Elect	47µF	6.3V
C140	1	1	1	1	DK46102300	Ceramic	C234	1	1	1	1	EJ47502510	Elect	4.7µF	25V
C141	1	1	1	1	DK46102300	Ceramic	C235	1	1	1	1	EJ47502510	Elect	4.7µF	25V
C142	1	1	1	1	DF15333310	Film	C236	1	1	1	1	EJ47502510	Elect	4.7µF	25V
C143	1	1	1	1	DF15472310	Film	C237	1	1	1	1	DK46562300	Ceramic	5600pF	± 10%
C144	1	1	1	1	EJ47502510	Elect	C238	1	1	1	1	EJ47502510	Elect	4.7µF	25V
C145	1	1	1	1	DF15103310	Film	C239	1	1	1	1	EJ47502510	Elect	4.7µF	25V
C146	1	1	1	1	DF15333310	Film	C240	1	1	1	1	DK46102300	Ceramic	1000pF	± 10%
C147	1	1	1	1	DF15104350	Film	C241	1	1	1	1	DK46102300	Ceramic	1000pF	± 10%
C148	1	1	1	1	DK46102300	Ceramic	C242	1	1	1	1	DF15333310	Film	0.033µF	± 5%
C149	1	1	1	1	EJ10601610	Elect	C243	1	1	1	1	DF15472310	Film	4700pF	± 5%
C150	1	1	1	1	DK46102300	Ceramic	C244	1	1	1	1	EJ47502510	Elect	4.7µF	25V
C151	1	1	1	1	EJ22405010	Elect	C245	1	1	1	1	DF15103310	Film	0.01µF	± 5%
							C246	1	1	1	1	DF15333310	Film	0.033µF	± 5%
							C247	1	1	1	1	DF15104350	Film	0.1µF	± 5%
							C248	1	1	1	1	DK46102300	Ceramic	1000pF	± 10%
							C249	1	1	1	1	EJ10601610	Elect	10µF	16V
							C250	1	1	1	1	DK46102300	Ceramic	1000pF	± 10%
							C251	1	1	1	1	EJ22405010	Elect	0.22µF	50V
							C252	1	1	1	1	EJ47502510	Elect	4.7µF	25V
							C253	1	1	1	1	EJ47502510	Elect	4.7µF	25V

- (U):for USA
- (N):for Europe
- (A):for Australia
- (P):for PX

REF. DESIG.	Q'TY				PART NO.	DESCRIPTION	REF. DESIG.	Q'TY				PART NO.	DESCRIPTION
	U	N	A	P				U	N	A	P		
C254	1	1	1	1	EJ47600610	Elect 47μF 6.3V	R123	1	1	1	1	Ri05101180	100Ω
C255	1	1	1	1	DF16102300	Ceramic 1000pF ± 10%	R124	1	1	1	1	Ri05472180	4.7kΩ
C257	1	1	1	1	DK46102300	Ceramic 1000pF ± 10%	R125	1	1	1	1	Ri05682180	6.8kΩ
C258	1	1	1	1	DF15122300	Film 1200pF ± 5%	R126	1	1	1	1	Ri05682180	6.8kΩ
C259	1	1	1	1	DF15224350	Film 0.22μF ± 5%	R127	1	1	1	1	Ri05392180	3.9kΩ
C261	1	1	1	1	EJ47502510	Elect 4.7μF 25V	R128	1	1	1	1	RA01040300	100kΩ (B) Trimming
CA01	1	1	1	1	EJ33601010	Elect 33μF 10V	R129	1	1	1	1	Ri05154180	150kΩ
CA02	1	1	1	1	EJ47601010	Elect 47μF 10V	R130	1	1	1	1	Ri05154180	150kΩ
CA03	1	1	1	1	EA10701030	Elect 100μF 10V	R131	1	1	1	1	Ri05103180	10kΩ
CA04	1	1	1	1	EJ22700410	Elect 220μF 4V	R132	1	1	1	1	Ri05103180	10kΩ
CA05	1	1	1	1	EJ10700610	Elect 100μF 6.3V	R133	1	1	1	1	Ri05561180	560Ω
CA06	1	1	1	1	EJ47601010	Elect 100μF 10V	R134	1	1	1	1	Ri05102180	1kΩ
CA07	1	1	1	1	EJ47601610	Elect 47μF 16V	R135	1	1	1	1	Ri05274180	270kΩ
CA08	1	1	1	1	DK46102300	Ceramic 1000pF ± 10%	R136	1	1	1	1	Ri05225180	2.2MΩ
CA09	1	1	1	1	EJ47601610	Elect 47μF 16V	R137	1	1	1	1	Ri05103180	10kΩ
CA10	1	1	1	1	EJ10700610	Elect 100μF 6.3V	R138	1	1	1	1	Ri05331180	330Ω
CA11	1	1	1	1	EA10701030	Elect 100μF 10V	R140	1	1	1	1	Ri05823180	82kΩ
CA12	1	1	1	1	EJ10700610	Elect 100μF 6.3V	R141	1	1	1	1	Ri05822180	8.2kΩ
△ CA13	1	1	1	1	EJ47502510	Elect 4.7μF 25V	R142	1	1	1	1	Ri05104180	100kΩ
CA14	1	1	1	1	DK46222300	Ceramic 0.022μF ± 10%	R143	1	1	1	1	Ri05222180	2.2kΩ
CA15	1	1	1	1	DK46222300	Ceramic 0.022μF ± 10%	R144	1	1	1	1	Ri05331180	330Ω
△ CA16	1	1	1	1	EA22701630	Elect 220μF 16V	R145	1	1	1	1	Ri05222180	2.2kΩ
△ CA17	1	1	1	1	EA10801630	Elect 1000μF 16V	R146	1	1	1	1	Ri05392180	3.9kΩ
CA18	1	1	1	1	DK46103300	Ceramic 0.01μF ± 10%	R147	1	1	1	1	Ri05331180	330Ω
CA19	1	1	1	1	EJ10700610	Elect 100μF 6.3V	R148	1	1	1	1	Ri05103180	10kΩ
CA20	1	1	1	1	EJ33600610	Elect 33μF 6.3V	R149	1	1	1	1	Ri05152180	1.5kΩ
CA22	1	1	1	1	EA47701630	Elect 470μF 16V	R150	1	1	1	1	Ri05682180	6.8kΩ
CA23	1	1	1	1	EJ47601610	Elect 47μF 16V	R151	1	1	1	1	Ri05152180	1.5kΩ
CA24	1	1	1	1	EJ47502510	Elect 4.7μF 25V	R153	1	1	1	1	Ri05824180	820kΩ
CA26	1	1	1	1	EA33700630	Elect 330μF 6.3V	R154	1	1	1	1	Ri05561180	560Ω
CA27	1	1	1	1	EJ47502510	Elect 4.7μF 25V	R155	1	1	1	1	Ri05272180	2.7kΩ
CA30	1	1	1	1	EA47601030	Elect 47μF 10V	R156	1	1	1	1	Ri05472180	4.7kΩ
CA31	1	1	1	1	DK16102300	Ceramic 1000pF ± 10%	R157	1	1	1	1	Ri05332180	3.3kΩ
CA50	1	1	1	1	EJ47502510	Elect 4.7μF 25V	R158	1	1	1	1	Ri05473180	47kΩ
						P100-RESISTORS	R159	1	1	1	1	Ri05224180	220kΩ
						(All Resistors are ± 5% & 1/8W Chip.)	R160	1	1	1	1	Ri05824180	820kΩ
R101	1	1	1	1	Ri05103180	10kΩ	R161	1	1	1	1	Ri05103180	10kΩ
R102	1	1	1	1	Ri05103180	10kΩ	R162	1	1	1	1	GD05333140	33kΩ 1/4W
R103	1	1	1	1	Ri05154180	150kΩ	R163	1	1	1	1	GD05152140	1.5kΩ 1/4W
R104	1	1	1	1	Ri05101180	100Ω	R164	1	1	1	1	Ri05561180	560Ω
R105	1	1	1	1	Ri05154180	150kΩ	R166	1	1	1	1	Ri05220180	22Ω
R107	1	1	1	1	Ri05562180	5.6kΩ	R167	1	1	1	1	Ri05103180	10kΩ
R108	1	1	1	1	Ri05332180	3.3kΩ	R168	1	1	1	1	Ri05273180	27kΩ
R109	1	1	1	1	Ri05332180	3.3kΩ	R169	1	1	1	1	Ri05101180	100Ω
R110	1	1	1	1	RA01030490	10kΩ (B) Trimming	R170	1	1	1	1	Ri05473180	47kΩ
R111	1	1	1	1	Ri05103180	10kΩ	R171	1	1	1	1	Ri05392180	3.9kΩ
R112	1	1	1	1	Ri05562180	5.6kΩ	R172	1	1	1	1	Ri05824180	820kΩ
R113	1	1	1	1	Ri05152180	1.5kΩ	R173	1	1	1	1	Ri05222180	2.2kΩ
R114	1	1	1	1	Ri01532180	15kΩ	R180	1	1	1	1	Ri05472180	4.7kΩ
R115	1	1	1	1	Ri05222180	2.2kΩ	R182	1	1	1	1	Ri05473180	47kΩ
R117	1	1	1	1	Ri05473180	47kΩ	R190	1	1	1	1	Ri05103180	10kΩ
R118	1	1	1	1	Ri05152180	1.5kΩ	R191	1	1	1	1	Ri05824180	820kΩ
R119	1	1	1	1	RA01030490	10kΩ (B) Trimming	R201	1	1	1	1	Ri05103180	10kΩ
R120	1	1	1	1	Ri05103180	10kΩ	R202	1	1	1	1	Ri05103180	10kΩ
R121	1	1	1	1	Ri05102180	1kΩ	R203	1	1	1	1	Ri05154180	150kΩ
R122	1	1	1	1	Ri05824180	820kΩ	R204	1	1	1	1	Ri05101180	100Ω
							R205	1	1	1	1	Ri05154180	150kΩ
							R207	1	1	1	1	Ri05562180	5.6kΩ
							R208	1	1	1	1	Ri05332180	3.3kΩ
							R209	1	1	1	1	Ri05332180	3.3kΩ

- (U):for USA
- (N):for Europe
- (A):for Australia
- (P):for PX

REF. DESIG.	Q'TY				PART NO.	DESCRIPTION
	U	N	A	P		
R210	1	1	1	1	RA01030490	10kΩ (B) Trimming
R211	1	1	1	1	Ri05103180	10kΩ
R212	1	1	1	1	Ri05562180	5.6kΩ
R213	1	1	1	1	Ri05152180	1.5kΩ
R214	1	1	1	1	Ri05153180	15kΩ
R215	1	1	1	1	Ri05222180	2.2kΩ
R217	1	1	1	1	Ri05473180	4.7kΩ
R218	1	1	1	1	Ri05152180	1.5kΩ
R219	1	1	1	1	RA01030490	10kΩ (B) Trimming
R220	1	1	1	1	Ri05102180	1kΩ
R221	1	1	1	1	Ri05102180	1kΩ
R222	1	1	1	1	Ri05824180	820kΩ
R223	1	1	1	1	Ri05101180	100Ω
R224	1	1	1	1	Ri05472180	4.7kΩ
R225	1	1	1	1	Ri05682180	6.8kΩ
R226	1	1	1	1	Ri05682180	6.8kΩ
R227	1	1	1	1	Ri05392180	3.9kΩ
R228	1	1	1	1	RA01040300	100kΩ (B) Trimming
R229	1	1	1	1	Ri05154180	150kΩ
R230	1	1	1	1	Ri05154180	150kΩ
R231	1	1	1	1	Ri05103180	10kΩ
R232	1	1	1	1	Ri05103180	10kΩ
R233	1	1	1	1	Ri05561180	560Ω
R234	1	1	1	1	Ri05102180	1kΩ
R235	1	1	1	1	Ri05274180	270kΩ
R236	1	1	1	1	Ri05225180	2.2MΩ
R237	1	1	1	1	Ri05103180	10kΩ
R238	1	1	1	1	Ri05331180	330Ω
R240	1	1	1	1	Ri05823180	82kΩ
R241	1	1	1	1	Ri05822180	8.2kΩ
R242	1	1	1	1	Ri05104180	100kΩ
R243	1	1	1	1	Ri05222180	2.2kΩ
R244	1	1	1	1	Ri05331180	330Ω
R245	1	1	1	1	Ri05222180	2.2kΩ
R246	1	1	1	1	Ri05392180	3.9kΩ
R247	1	1	1	1	Ri05331180	330Ω
R248	1	1	1	1	Ri05103180	10kΩ
R249	1	1	1	1	Ri05473180	4.7kΩ
R250	1	1	1	1	Ri05682180	6.8kΩ
R251	1	1	1	1	Ri05152180	1.5kΩ
R253	1	1	1	1	Ri05824180	820kΩ
R254	1	1	1	1	Ri05561180	560Ω
R255	1	1	1	1	Ri05272180	2.7kΩ
R256	1	1	1	1	Ri05472180	4.7kΩ
R257	1	1	1	1	Ri05332180	3.3kΩ
R258	1	1	1	1	Ri05473180	4.7kΩ
R259	1	1	1	1	Ri05224180	220kΩ
R260	1	1	1	1	Ri05824180	820kΩ
R261	1	1	1	1	Ri05103180	10kΩ
R262	1	1	1	1	GD05333140	33kΩ 1/4W
R263	1	1	1	1	GD05152140	1.5kΩ 1/4W
R264	1	1	1	1	Ri05561180	560Ω
R266	1	1	1	1	Ri05220180	22Ω
R267	1	1	1	1	Ri05103180	10kΩ
R268	1	1	1	1	Ri05273180	27kΩ
R269	1	1	1	1	Ri05101180	100Ω
R270	1	1	1	1	Ri05473180	4.7kΩ

REF. DESIG.	Q'TY				PART NO.	DESCRIPTION
	U	N	A	P		
R271	1	1	1	1	Ri05392180	3.9kΩ
R272	1	1	1	1	Ri05824180	820kΩ
R273	1	1	1	1	Ri05222180	2.2kΩ
R280	1	1	1	1	Ri05472180	4.7kΩ
R282	1	1	1	1	Ri05473180	4.7kΩ
R290	1	1	1	1	Ri05103180	10kΩ
R291	1	1	1	1	Ri05824180	820kΩ
RA01	1	1	1	1	Ri05224180	220kΩ
RA02	1	1	1	1	Ri05273180	27kΩ
RA03	1	1	1	1	Ri05104180	100kΩ
RA04	1	1	1	1	Ri05104180	100kΩ
RA05	1	1	1	1	Ri05104180	100kΩ
RA06	1	1	1	1	Ri05104180	100kΩ
RA07	1	1	1	1	Ri05104180	100kΩ
RA08	1	1	1	1	Ri05104180	100kΩ
RA09	1	1	1	1	Ri04103180	10kΩ
RA11	1	1	1	1	Ri05273180	27kΩ
RA12	1	1	1	1	Ri05153180	15kΩ
RA13	1	1	1	1	Ri05562180	5.6kΩ
RA14	1	1	1	1	Ri05273180	27kΩ
RA16	1	1	1	1	Ri05561180	560Ω
RA17	1	1	1	1	Ri05272180	2.7kΩ
RA18	1	1	1	1	Ri05472180	4.7kΩ
RA19	1	1	1	1	Ri05393180	39kΩ
RA20	1	1	1	1	Ri05682180	6.8kΩ
RA21	1	1	1	1	Ri05222180	2.2kΩ
RA22	1	1	1	1	Ri05822180	8.2kΩ
RA24	1	1	1	1	Ri05331180	330Ω
RA25	1	1	1	1	RA01040300	100kΩ (B) Trimming
RA27	1	1	1	1	Ri05103180	10kΩ
RA28	1	1	1	1	Ri05103180	10kΩ
RA29	1	1	1	1	Ri05473180	4.7kΩ
RA30	1	1	1	1	Ri05332180	3.3kΩ
RA31	1	1	1	1	Ri05470180	4.7Ω
RA32	1	1	1	1	Ri05102180	1kΩ
RA33	1	1	1	1	Ri05103180	10kΩ
RA34	1	1	1	1	Ri05104180	100kΩ
RA35	1	1	1	1	Ri05104180	100kΩ
RA36	1	1	1	1	Ri05331180	330Ω
RA37	1	1	1	1	Ri05222180	2.2kΩ
RA38	1	1	1	1	Ri05101180	4.7Ω
RA39	1	1	1	1	GD05470140	4.7Ω 1/4W
RA40	1	1	1	1	GD05470140	4.7Ω 1/4W
RA41	1	1	1	1	Ri05473180	4.7kΩ
RA42	1	1	1	1	Ri05473180	4.7kΩ
RA45	1	1	1	1	Ri05103180	10kΩ
RA46	1	1	1	1	Ri05047180	4.7Ω
RA47	1	1	1	1	Ri05473180	4.7kΩ
RA48	1	1	1	1	Ri05473180	4.7kΩ
RV01	1	1	1	1	RM01030240	10kΩ (B) Variable
RV02	1	1	1	1	RD05030190	50kΩ (B) Variable

- (U):for USA
- (N):for Europe
- (A):for Australia
- (P):for PX

REF. DESIG.	Q'TY				PART NO.	DESCRIPTION	REF. DESIG.	Q'TY				PART NO.	DESCRIPTION
	U	N	A	P				U	N	A	P		
P100-SEMICONDUCTORS						QA27	1	1	1	1	HZ20001020	Diode MA151WK Chip	
Q101	1	1	1	1	HX327121A0	Transistor 2SC2712 (G) Chip	QA28	1	1	1	1	HX327121A0	Transistor 2SC2712 (G) Chip
Q102	1	1	1	1	HX327121A0	Transistor 2SC2712 (G) Chip	QA29	1	1	1	1	HX327121A0	Transistor 2SC2712 (G) Chip
Q103	1	1	1	1	HX327121A0	Transistor 2SC2712 (G) Chip	△ QA30	1	1	1	1	HT318462B0	Transistor 2SC1846 (F,R)
Q104	1	1	1	1	HX327121A0	Transistor 2SC2712 (G) Chip	△ QA31	1	1	1	1	HD20001000	Diode 1S1555
Q105	1	1	1	1	BA20002210	Transistor DTC124 SMT Chip	△ QA32	1	1	1	1	HD30050060	Zener RD15EB3
Q106	1	1	1	1	BA20002210	Transistor DTC124 SMT Chip	QA33	1	1	1	1	HZ20001020	Diode MA151WK Chip
Q107	1	1	1	1	HX327121A0	Transistor 2SC2712 (G) Chip	QA35	1	1	1	1	HX327121A0	Transistor 2SC2712 (G) Chip
Q108	1	1	1	1	HX327121A0	Transistor 2SC2712 (G) Chip	QA36	1	1	1	1	BA20002210	Transistor DTC124 (S) Chip
Q109	1	1	1	1	HZ20001020	Diode MA151WK Chip	QA37	1	1	1	1	BA20002210	Transistor DTC124 (S) Chip
Q110	1	1	1	1	HX327121A0	Transistor 2SC2712 (G) Chip	QA38	1	1	1	1	HX111621A0	Transistor 2SA1162 Chip
Q111	1	1	1	1	BA20002210	Transistor DTC124 SMT Chip	QA39	1	1	1	1	HX111621A0	Transistor 2SA1162 Chip
Q112	1	1	1	1	BA20002210	Transistor DTC124 SMT Chip	QA40	1	1	1	1	HD20001000	Diode 1S1555
Q113	1	1	1	1	HX327121A0	Transistor 2SC2712 (G) Chip	QA41	1	1	1	1	HZ20001020	Diode MA151WK Chip
Q114	1	1	1	1	HX327121A0	Transistor 2SC2712 (G) Chip	QA45	1	1	1	1	HX111621A0	Transistor 2SA1162 (G) Chip
Q115	1	1	1	1	BA20002210	Transistor DTC124 SMT Chip	QA46	1	1	1	1	HZ20001020	Diode MA151WK Chip
Q116	1	1	1	1	HZ20001020	Diode MA151WK Chip	P100-MISCELLANEOUS						
Q117	1	1	1	1	HZ20001020	Diode MA151WK Chip	J101	1	1	1	1	YP06002420	Plug (6P) R/P Head
Q118	1	1	1	1	HZ20001020	Diode MA151WK Chip	J102	1	1	1	1	BY01130010	Jack DIN/RCA
Q119	1	1	1	1	HX413281R0	Transistor 2SD1328 (R) Chip	J103	1	1	1	1	YJ01002280	Jack Left Mic
Q201	1	1	1	1	HX327121A0	Transistor 2SC2712 (G) Chip	J104	1	1	1	1	YJ01002280	Jack Right Mic
Q202	1	1	1	1	HX327121A0	Transistor 2SC2712 (G) Chip	J105	1	1	1	1	YJ01002280	Jack Head Phone
Q203	1	1	1	1	HX327121A0	Transistor 2SC2712 (G) Chip	J106	1	1	1	1	YP06002370	Plug (2P) Erase Head
Q204	1	1	1	1	HX327121A0	Transistor 2SC2712 (G) Chip	J107	1	1	1	1	YJ06002550	Jack (5P) OSC
Q205	1	1	1	1	BA20002210	Transistor DTC124 SMT Chip	J108	1	1	1	1	YJ04000840	Jack DC
Q206	1	1	1	1	BA20002210	Transistor DTC124 SMT Chip	J109	1	1	1	1	YJ06003050	Jack (5P) SW-1
Q207	1	1	1	1	HX327121A0	Transistor 2SC2712 (G) Chip	J110	1	1	1	1	YJ06003050	Jack (5P) SW-2
Q208	1	1	1	1	HX327121A0	Transistor 2SC2712 (G) Chip	J111	1	1	1	1	YJ06003030	Jack (3P) Power
Q209	1	1	1	1	HZ20001020	Diode MA151WK Chip	J112	1	1	1	1	YJ06003080	Jack (8P) MECHA PWB
Q210	1	1	1	1	HX327121A0	Transistor 2SC2712 (G) Chip	J113	1	1	1	1	YJ06003020	Jack (2P) SP
Q211	1	1	1	1	BA20002210	Transistor DTC124 SMT Chip	J114	1	1	1	1	YJ06003050	Jack (5P) Meter
Q212	1	1	1	1	BA20002210	Transistor DTC124 SMT Chip	J115	1	1	1	1	YU03090260	Jumper L=90
Q213	1	1	1	1	HX327121A0	Transistor 2SC2712 (G) Chip	L101	1	1	1	1	LC25650700	Choke Coil 5.6mH
Q214	1	1	1	1	HX327121A0	Transistor 2SC2712 (G) Chip	L102	1	1	1	1	LC22260700	Choke Coil 22mH
Q215	1	1	1	1	BA20002210	Transistor DTC124 SMT Chip	L201	1	1	1	1	LC25650700	Choke Coil 5.6mH
Q216	1	1	1	1	HZ20001020	Diode MA151WK Chip	L202	1	1	1	1	LC22260700	Choke Coil 22mH
Q217	1	1	1	1	HZ20001020	Diode MA151WK Chip	LA01	1	1	1	1	LC14730040	Choke Coil 47μH
Q218	1	1	1	1	HZ20001020	Diode MA151WK Chip	LA02	1	1	1	1	LC21050700	Choke Coil 1μH
Q219	1	1	1	1	HX413281R0	Transistor 2SD1328 (R)	S101	1	1	1	1	SP02020730	Push Swtich Limiter
QA01	1	1	1	1	HC10053010	IC HA12051	S102	1	1	1	1	SP02020740	Push Switch BATT Check
QA02	1	1	1	1	HC10040210	IC BA1102F	S103	1	1	1	1	SS01030040	Slide Switch MONI mode
QA03	1	1	1	1	HC10038210	IC BA5208F	S104	1	1	1	1	SS01020490	Slide Switch SP. MONI
QA04	1	1	1	1	HC406600Z0	IC 4066	S105	1	1	1	1	SP02020740	Push Swtich R/P SW
QA05	1	1	1	1	HC10017090	IC NJM2043DD	T101	1	1	1	1	LS10440060	MPX Coil Dolby NR
QA07	1	1	1	1	BA20002210	Transistor DTC124 SMT Chip	T201	1	1	1	1	LS10440060	MPX Coil Dolby NR
QA08	1	1	1	1	HX111621A0	Transistor 2SA1162 Chip	△ TA01	1	1	1	1	TC10100080	OSC Transf.
QA09	1	1	1	1	HZ20001020	Diode MA151WK Chip							
QA10	1	1	1	1	HZ20001020	Diode MA151WK Chip							
QA16	1	1	1	1	HZ20001020	Diode MA151WK Chip							
△ QA17	1	1	1	1	HT313831D0	Transistor 2SC1383 (S)							
QA18	1	1	1	1	HX327121A0	Transistor 2SC2712 (G) Chip							
QA19	1	1	1	1	HX327121A0	Transistor 2SC2712 (G) Chip							
QA20	1	1	1	1	BA20002210	Transistor DTC124 SMT Chip							
QA21	1	1	1	1	BA20002210	Transistor DTC124 SMT Chip							
QA22	1	1	1	1	BA20002210	Transistor DTC124 SMT Chip							
QA23	1	1	1	1	BA20002210	Transistor DTC124 SMT Chip							
QA24	1	1	1	1	HT318462B0	Transistor 2SC1846 (R,S)							
QA25	1	1	1	1	HD30002020	Zener MA1039							
QA26	1	1	1	1	HZ20001020	Diode MA151WK Chip							

- (U):for USA
- (N):for Europe
- (A):for Australia
- (P):for PX

REF. DESIG.	Q'TY				PART NO.	DESCRIPTION
	U	N	A	P		
P200	1	1	1	1	WB153T1520 ZZ153T1520	P200-Bias OSC Circuit Board P.W. Board Bias OSC P.W. Board Assembly
						P200-CAPACITORS
CB01	1	1	1	1	CT15000030	50pF Trimming
CB02	1	1	1	1	CT15000030	50pF Trimming
CB03	1	1	1	1	DF15562310	Film 5600pF ±5%
CB04	1	1	1	1	DF15153310	Film 0.015μF ±5%
CB05	1	1	1	1	DF15103550	Film 0.01μF ±5%
CB06	1	1	1	1	DD45150300	Ceramic 15pF ±5% Chip
CB07	1	1	1	1	DD45150300	Ceramic 15pF ±5% Chip
						P200-RESISTORS (All Resistors are ±5% 1/8W Chip)
RB01	1	1	1	1	Ri05333180	33kΩ
RB02	1	1	1	1	Ri05047180	4.7Ω
						P200-SEMICONDUCTORS
QB01	1	1	1	1	HT313831D0	Transistor 2SC1383 (S)
						P200-MISCELLANEOUS
JB01	1	1	1	1	YP06003260	Plug (5P)
TB01	1	1	1	1	TC10100070	Bias OSC Coil
						P300-Mic Switch Circuit Board
P300	1	1	1	1	WB153T1530 ZZ153T1530	P.W. Board Mic Switch P.W. Board Assembly
						P300-MISCELLANEOUS
SS01	1	1	1	1	SS01030050	Slide Switch
						P400-L.E.D. Circuit Board
P400	1	1	1	1	WB153T1540 ZZ153T1540	P.W. Board L.E.D. P.W. Board Assembly
						P400-SEMICONDUCTORS
QR01	1	1	1	1	Hi10056020	L.E.D. LN228RP
QR02	1	1	1	1	Hi10025020	L.E.D. LN222RP
						P500-Rec/Play Sub Circuit Board
P500	1	1	1	1	WB153T1550 ZZ153T1550	P.W. Board Rec/Play Sub Circuit P.W. Board Assembly
						P500-RESISTORS
△ RP01	1	1	1	1	GJ05100010	1Ω 1W ±5%
						P500-MISCELLANEOUS
JP01	1	1	1	1	YB00060080	Connective Cord (2P)

REF. DESIG.	Q'TY				PART NO.	DESCRIPTION
	U	N	A	P		
P600	1	1	1	1	WC153T2310 ZZ153T2310	P600-Mecha Control Circuit Board P.W. Board Mecha Control P.W. Board Assembly
						P600-CAPACITORS
CM01	1	1	1	1	EJ22505010	Elect 2.2μF 50V
CM02	1	1	1	1	EJ10701030	Elect 100μF 10V
CM03	1	1	1	1	EA22701630	Elect 220μF 16V
CM04	1	1	1	1	EJ10601610	Elect 10μF 16V
CM05	1	1	1	1	DK46102300	Ceramic 0.001μF ±10% Chip
CM06	1	1	1	1	EJ10701010	Elect 100μF 10V
CM07	1	1	1	1	EJ22601610	Elect 22μF 16V
CM08	1	1	1	1	EJ22601610	Elect 22μF 16V
CM09	1	1	1	1	EJ10601610	Elect 10μF 16V
						P600-RESISTORS (All Resistors are ±5% 1/8W Chip)
RM01	1	1	1	1	NB50052390	0.5Ω 1/4W 3900PPM Kanon
RM02	1	1	1	1	NB51032200	10kΩ 1/4W 2000PPM Kanon
RM03	1	1	1	1	Ri05027180	2.7Ω
RM04	1	1	1	1	Ri05821180	820Ω
RM05	1	1	1	1	RA01020330	1kΩ (B) Trimming
RM10	1	1	1	1	Ri05473180	47kΩ
RM11	1	1	1	1	Ri05472180	4.7kΩ
RM12	1	1	1	1	Ri05473180	47kΩ
RM13	1	1	1	1	Ri05821180	820Ω
RM14	1	1	1	1	Ri05473180	47kΩ
RM15	1	1	1	1	Ri05472180	4.7kΩ
RM16	1	1	1	1	Ri05101180	100Ω
RM17	1	1	1	1	Ri05821180	820Ω
						P600-SEMICONDUCTORS
QM01	1	1	1	1	HC10037020	IC AN6612
QM02	1	1	1	1	HT10966100	Transistor 2SA966 (O)
QM09	1	1	1	1	HZ20001020	Diode MA151WK Chip
QM10	1	1	1	1	HD20015030	Diode DS135D
QM11	1	1	1	1	HX413281R0	Transistor 2SD1328 (R)
QM12	1	1	1	1	BA20002210	Transistor DTC124 SMT
QM13	1	1	1	1	HZ20001020	Diode MA151WK Chip
QM14	1	1	1	1	BA20002210	Transistor DTC124 SMT
QM15	1	1	1	1	HX413281R0	Transistor 2SD1328
QM16	1	1	1	1	HZ20001020	Diode MA151WK Chip
QM17	1	1	1	1	HZ20001020	Diode MA151WK Chip
QM18	1	1	1	1	HZ20001020	Diode MA151WK Chip
QM19	1	1	1	1	HC10039210	IC BA337
QM20	1	1	1	1	HC10024020	IC DN6838
QM22	1	1	1	1	HZ20001020	Diode MA151WK Chip
QM23	1	1	1	1	HZ20001020	Diode MA151WK Chip
						P600-MISCELLANEOUS
JM01	1	1	1	1	YB00070080	Connective Cord (8P)
JM02	1	1	1	1	YB00050120	Connective Cord (5P)

- (U):for USA
- (N):for Europe
- (A):for Australia
- (P):for PX

REF. DESIG.	Q'TY				PART NO.	DESCRIPTION
	U	N	A	P		
P700	1	1	1	1	WC153T2320 ZZ153T2320	P700-Control Switch Circuit Board P.W. Board Control Switch P.W. Board Assembly
	1	1	1	1		
RC01	1	1	1	1	RB02020020	2k Ω (B) Variable
RC02	1	1	1	1	RB02020020	2k Ω (B) Variable
RC03	1	1	1	1	Ri05562180	5.6k Ω \pm 5% 1/8W
RC04	1	1	1	1	Ri05152180	1.5k Ω \pm 5% 1/8W
P700-MISCELLANEOUS						
JC01	1	1	1	1	YB00100900	Connective Cord (5P) L = 100
JC02	1	1	1	1	YB00150430	Connective Cord (5P) L = 150
JC03	1	1	1	1	YJ06003250	Jack (5P)
SC01	1	1	1	1	SS01030030	Slide Switch
SC02	1	1	1	1	SS02030250	Slide Switch
SC03	1	1	1	1	SS01020470	Slide Switch

REF. DESIG.	Q'TY				PART NO.	DESCRIPTION
	U	N	A	P		
P800	1	1	1	1	WC153T2330 ZZ153T2330	P800-Light Circuit Board P.W. Board Light P.W. Board Assembly
	1	1	1	1		
P800-CAPACITORS						
CL01	1	1	1	1	EJ10601610	Elect 10 μ F 16V
P800-RESISTORS (All Resistors are \pm 5% 1/8W Chip)						
RL01	1	1	1	1	Ri05330180	33 Ω
RL02	1	1	1	1	Ri05330180	33 Ω
RL03	1	1	1	1	Ri05221180	220 Ω
RL04	1	1	1	1	Ri05105180	1M Ω
RL05	1	1	1	1	Ri05105180	1M Ω
RL06	1	1	1	1	Ri05103180	10k Ω
RL07	1	1	1	1	Ri05473180	47k Ω
P800-SEMICONDUCTORS						
QL01	1	1	1	1	Hi10017210	L.E.D. LD-7021MT
QL02	1	1	1	1	Hi10017210	L.E.D. LD-7021MT
QL03	1	1	1	1	HC401100Z0	IC 4066
QL04	1	1	1	1	HX327121A0	Transistor 2SC2712 (G)
JL01	1	1	1	1	YB00140150	Connective Cord (5P)
P900-Mic Mode Circuit Board						
P900	1	1	1	1	WB153T1560 ZZ153T1560	P.W. Board Mic Mode P.W. Board Assembly
	1	1	1	1		
S110	1	1	1	1	SS02020740	Slide Switch

(W01-99)	Assembly and Wiring
(T01-99)	Adjustment
(X01-00)	Correction

NOTE ON SAFETY:
Symbol Δ Fire or electrical shock hazard. Only original parts should be used to replace any part marked with symbol Δ . Any other component substitution (other than original type), may increase risk of fire or electrical shock hazard.

8. TECHNICAL SPECIFICATIONS

Tape Drive System	Single Capstan Drive
Cartridge	Philips type compact cassette
Track System	Compatible Stereo 4-track 2-channel
Tape Speed	4.75 cm/sec.
Heads	2 Head System
Composition Hi-B Permalloy	Rec/Play: Super Hard Metal Alloy
	Erase: Duel Gap Ferrite
Motor	DC Servo Motor
Overall Frequency Response at -20dB	
Normal Tape	30 Hz ~ 16 kHz
CrO ₂ Tape	20 Hz ~ 18 kHz
Metal Tape	20 Hz ~ 20 kHz
Signal-to-Noise Ratio: with A-Curve Filter to 3%: Distortion (K3)	
Dolby B (ON)	65 dB
Dolby (OFF)	54 dB
Wow and Flutter	
DIN WTD	0.25%
Outputs	
Line Level/Impedance	500 mV/3 k ohms
Headphone Level/Impedance	100 mV/8 ohms
Input (Level at 0 VU)	
Line Sensitivity/Impedance	100 mV/50 k ohms
DIN Sensitivity/Impedance	10 mV/10 k ohms
Mic Sensitivity/Impedance	0.32 mV/10 k ohms
Fast Rewind Time	110 sec. (C-60)
Fast Forward Time	110 sec. (C-60)
Power Requirements	3 UM-1 "D" size Rechargeable Model RB430 AC Adapter 110-120V, 220-240V, AC 50, 60 Hz
Power Consumption	AC230V • 6.5W/DC4.5V • 3.5W
Dimensions	
Panel Width	227 mm
Panel Height	50 mm
Depth	165 mm
Weight	1.2 kg

Specifications and appearance are subject to change for modification without notice.

9. SCHEMATIC DIAGRAM

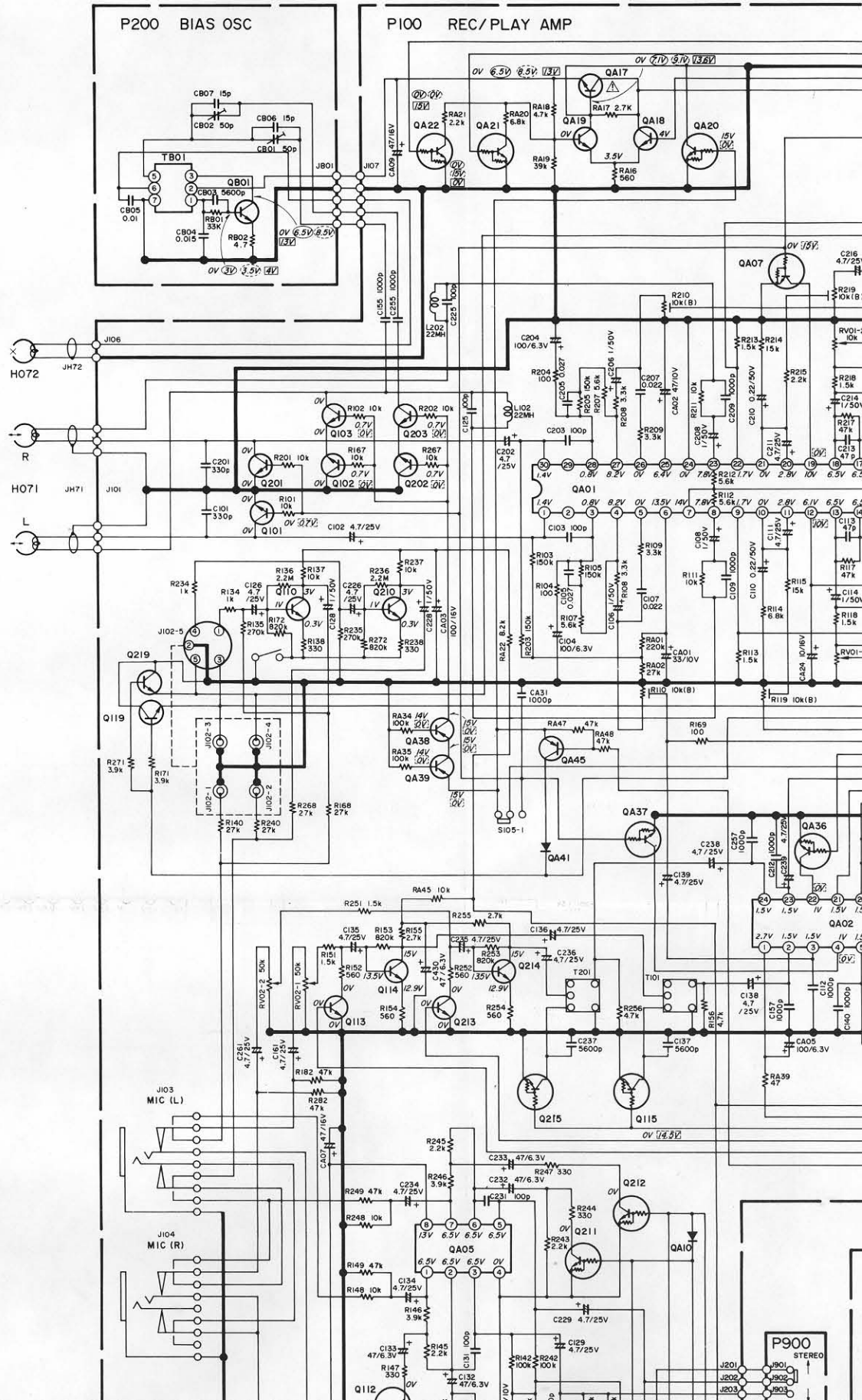

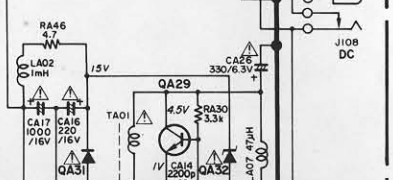
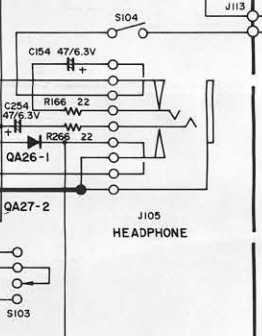
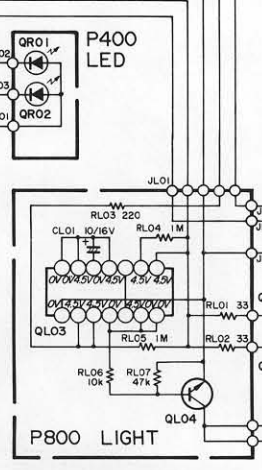
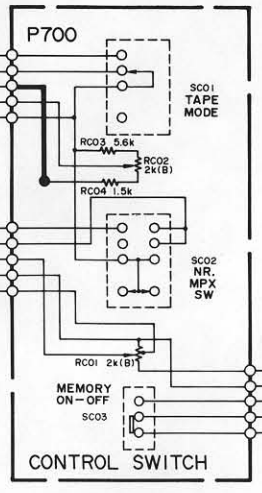
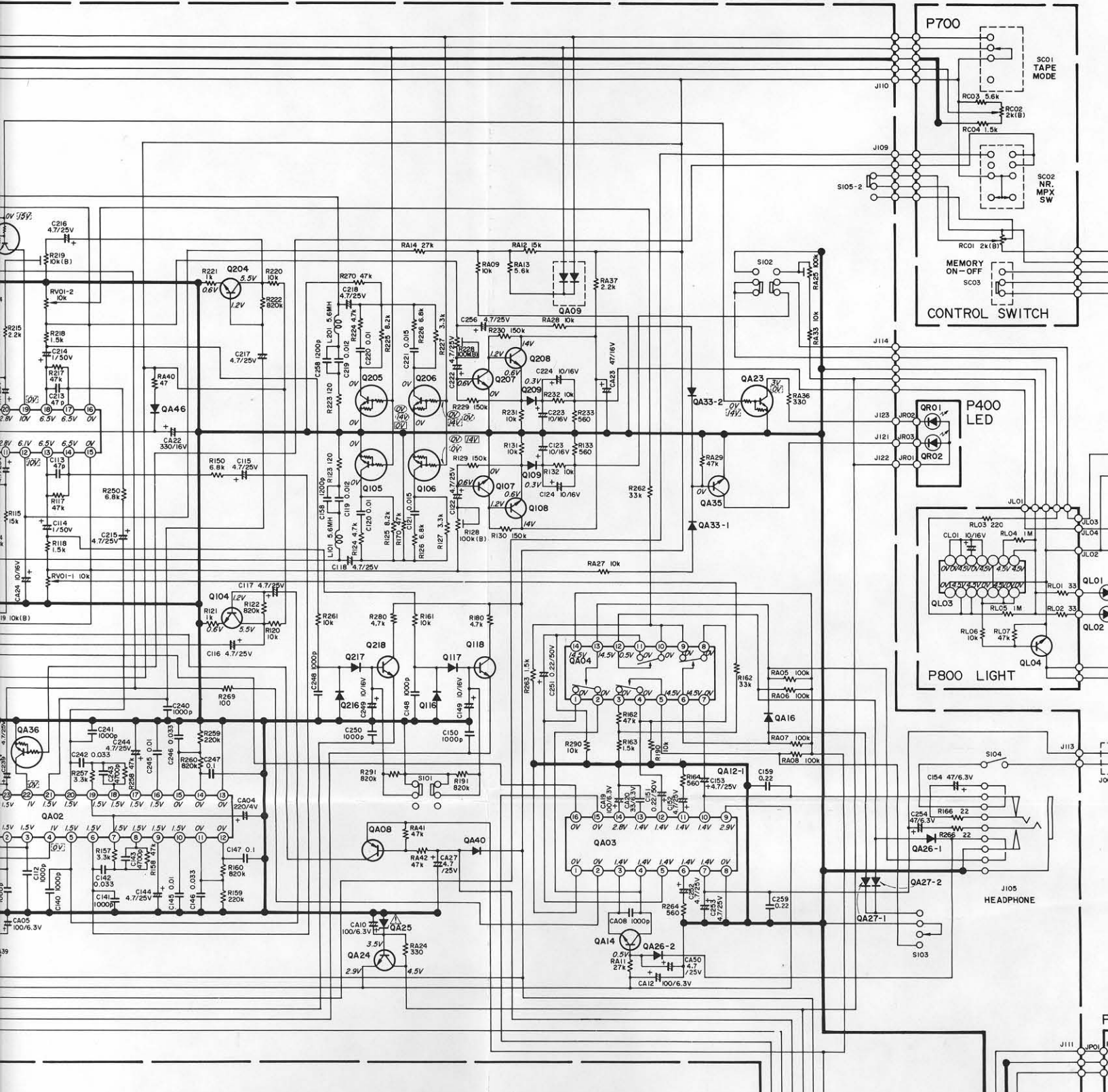

MODEL CP230

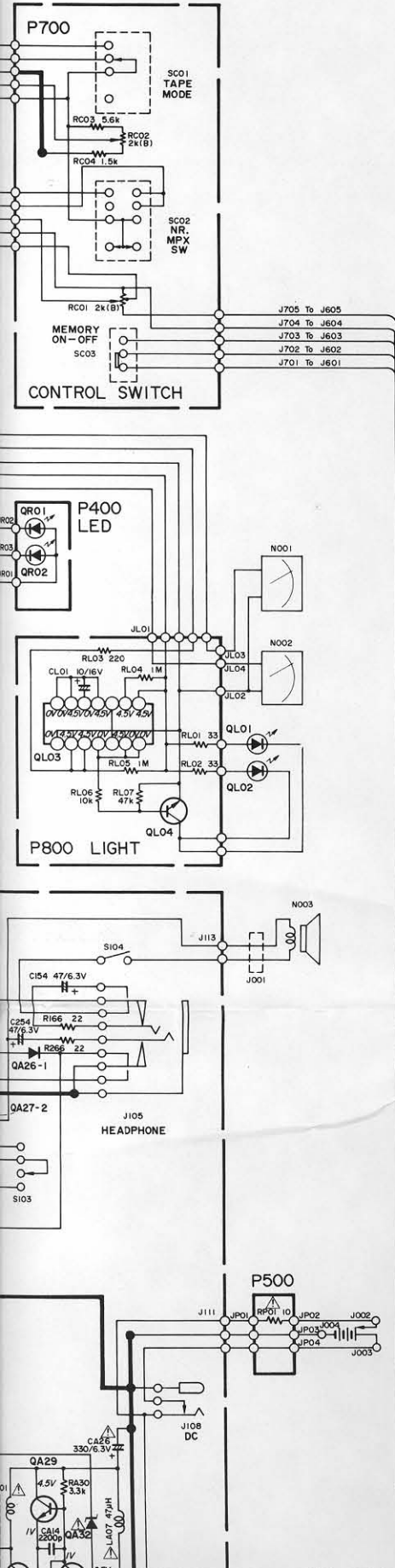

Q101 ~ Q104, Q107, Q108, Q110, Q113, Q114, Q118
 Q201 ~ Q204, Q207, Q208, Q210, Q218
 Q213, Q214, QA06, QA13 ~ QA15
 QA18, QA19, QA28, QA29, QA34
 QA35, QL04
 HX327121A0
 2SC2712 (G)

Q105, Q106, Q111, Q112, Q115
 Q205, Q206, Q211, Q212, Q215
 QA07, QA20 ~ QA23, QA36, QA37
 QM12, QM14, QM21
 BA20002210
 DTC124 SMT

Q109, Q116, Q117, Q209
 Q216, Q217, QA09, QA10
 QA16, QA26, QA27, QA33, QA41
 QM09, QM13, QM16
 HZ20001020
 MA151WA0

QA01
 HC10053010
 HAI2051

QA02
 HC10040210
 BA1102F

QA03
 HC10038210
 BA5208F

QA04
 HC40660020
 4066

QA05
 HC10017090
 NJM2043DD

QA08, QA38, QA39, QA45
 HX111621A0
 2SA1162

QA17, QB01
 HT313831D0
 2SC1383S

QA25
 HD30002020
 MA1039

QA24, QA30
 HT318462B0
 2SC1846 (F, R)

QA31, QA40
 HD20001000
 IS1555

QA32
 HD30050060
 RD15EB3

QL03
 HC40110020
 4011

QM01
 HC10037020
 AN6612

QM02
 HT10966100
 2SA966(O)

QM10
 HD20015030
 DS135D

Q119, Q219
 QM11, QM15
 HX413281R0
 2SD1328

QM19
 HC10039210
 BA337

QM20
 HC10024020
 DN6838

QR01
 H110056020
 LN228RP

QR02
 H110025020
 LN222RP

QL01, QL02
 H110017210
 LD-7021MT



2SA1162
 2SC2712
 2SD1328

MA151WA



DTC124



2SA683
 2SA966
 2SC1383

DN6383

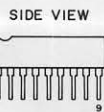

BA337

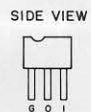

DTC124

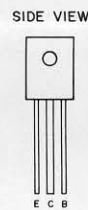

2SC1846

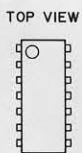

4011
 4066

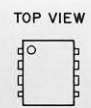

NJM2043DD

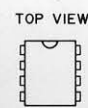

AN6612

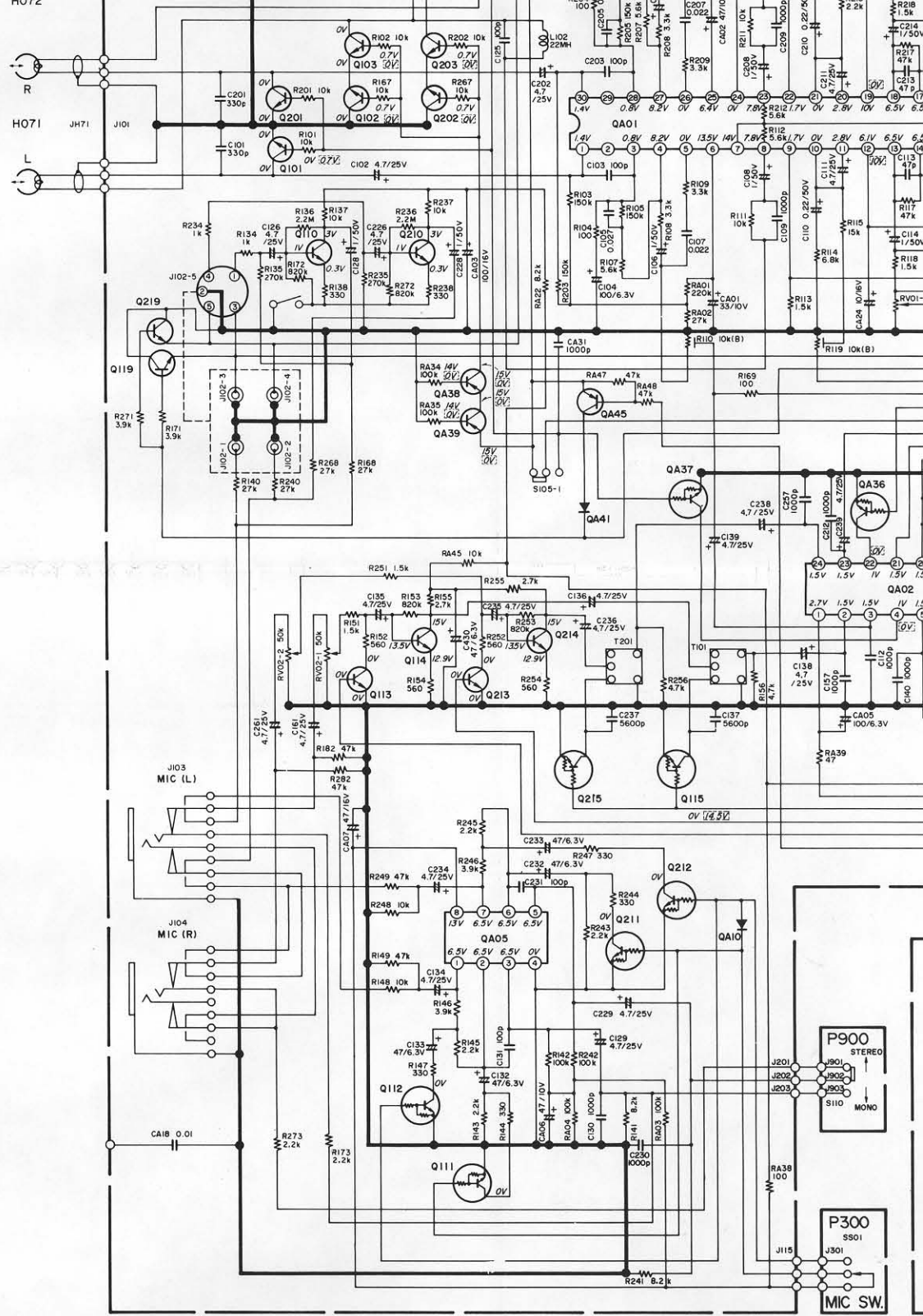

NOTE: ∇ FOR PLAY POSITION
 \square FOR REC POSITION
 \circ FOR NORMAL POSITION
 \square FOR CR2 POSITION
 \square FOR METAL POSITION

NOTE ON SAFETY:

Symbol ∇ Fire or electrical shock hazard. Only original parts should be used to replace any part marked with symbol ∇ . Any other component substitution (other than original type), may increase risk of fire or electrical shock hazard.

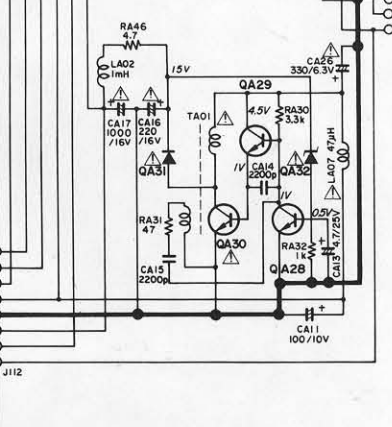
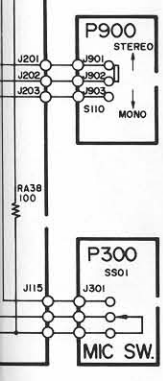
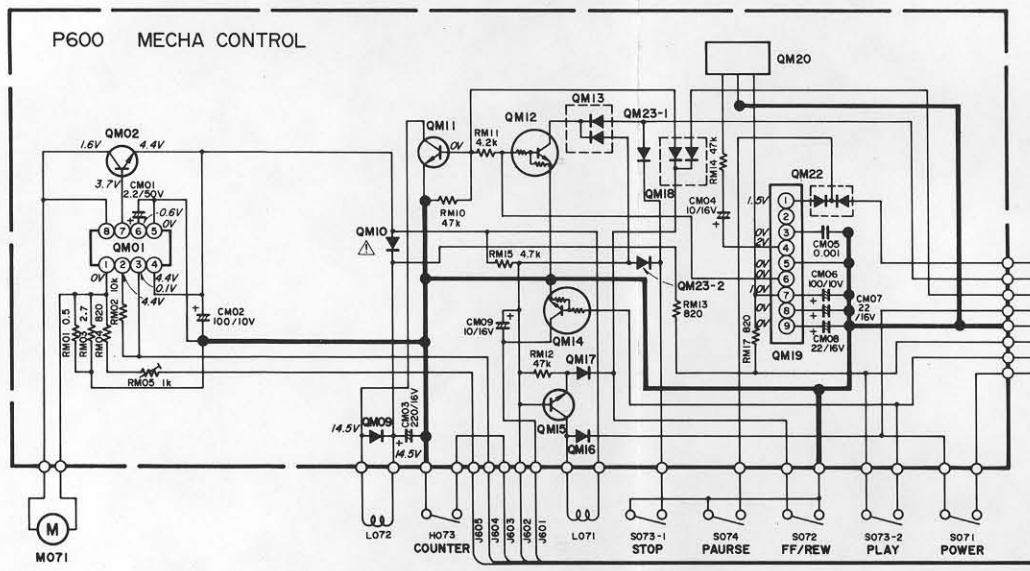
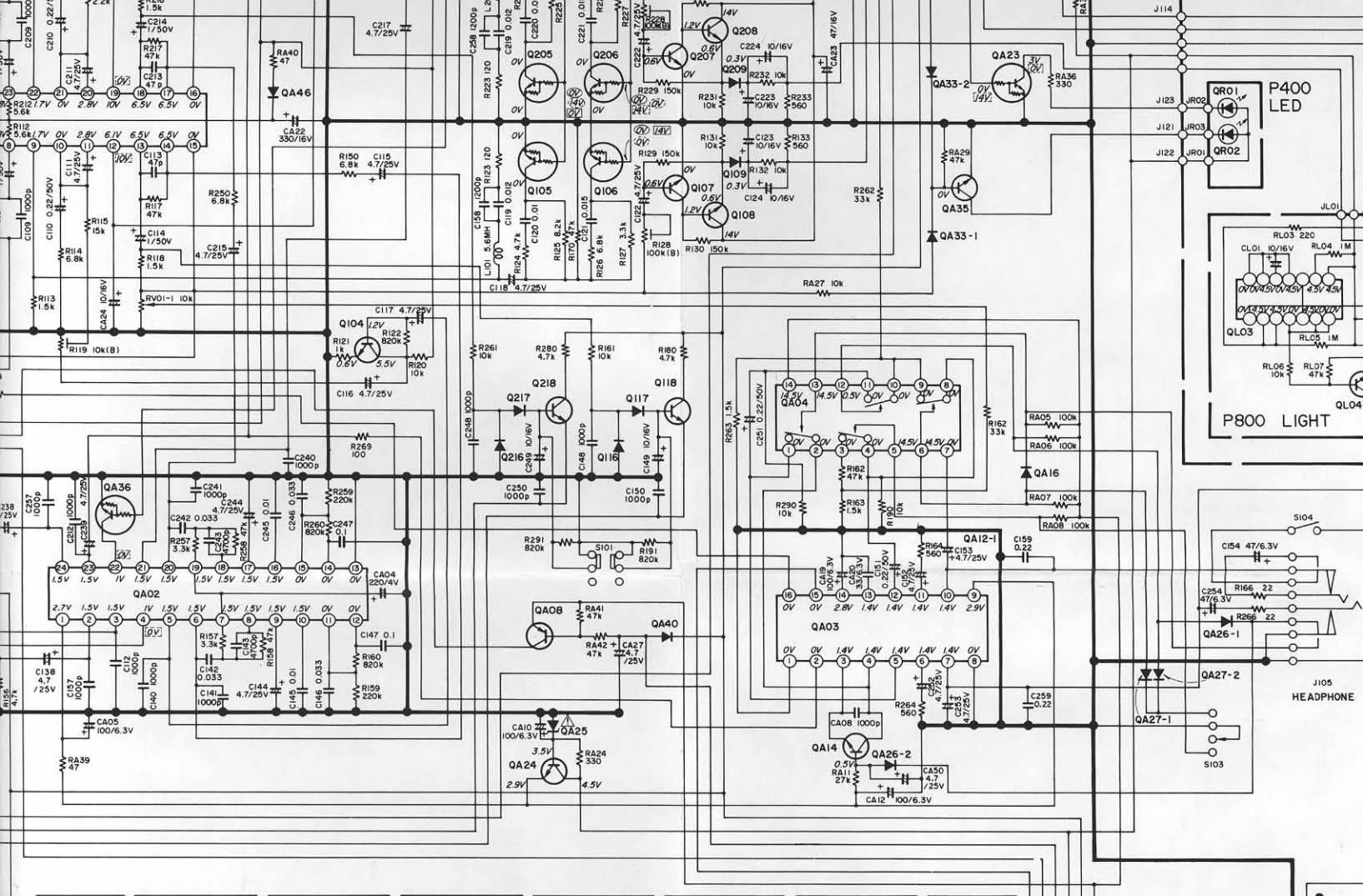

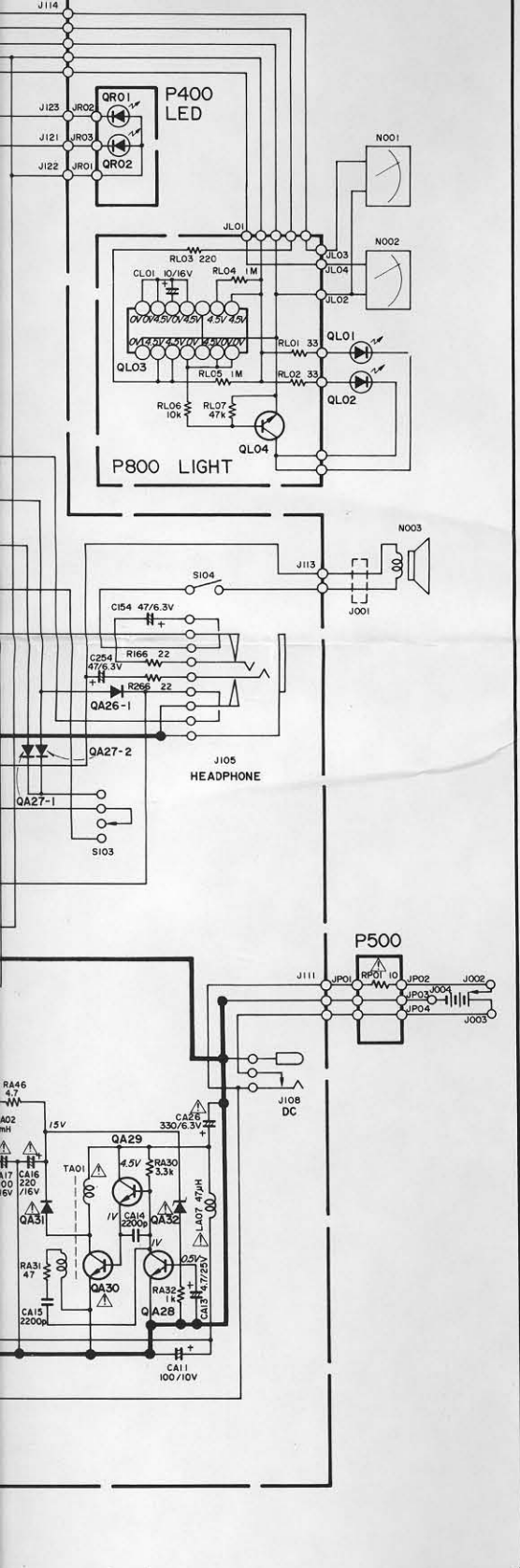

QA03
HC10038210
BA5208F

2SA1162
2SC2712
2SD1328

MA151WA

QA04
HC406600Z0
4066



DTC124

QA05
HC10017090
NJM2043DD

QA08,QA38,QA39,QA45
HX111621A0
2SA1162

QA17,QB01
HT313831D0
2SC1383S

QA25
HD30002020
MA1039



2SA683
2SA966
2SC1383



DN6383

QA24,QA30
HT318462B0
2SC1846(F,R)

QA31,QA40
HD20001000
IS1555

QA32
HD30050060
RD15EB3

QL03
HC401100Z0
4011

QM01
HC10037020
AN6612

SIDE VIEW

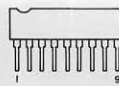

BA337

SIDE VIEW



DTC124

SIDE VIEW



2SC1846

QM02
HT10966100
2SA966(O)

QM10
HD20015030
DS135D

Q119,Q219
QM11,QM15
HX413281R0
2SD1328

QM19
HC10039210
BA337

QM20
HC10024020
DN6838

QR01
HI10056020
LN228RP

TOP VIEW



4011
4066

TOP VIEW



NJM2043DD

TOP VIEW



AN6612

QR02
HI10025020
LN222RP

QL01,QL02
HI10017210
LD-7021MT

TOP VIEW

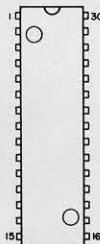

HAI2051

TOP VIEW



BA1102F

TOP VIEW

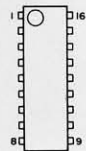

BA5208AF

Components and wiring are subject to change for modification without notice.