

Service Manual

74 DP870/02B
DP870 KBL, KGL, FBL, UBL
Digital Processor



TABLE OF CONTENTS

SECTION	PAGE
1. TECHNICAL SPECIFICATIONS	1
2. TECHNICAL DESCRIPTION	2
3. SIGNAL AND CIRCUIT DESCRIPTION	2
4. BLOCK DIAGRAM	3
5. SCHEMATIC DIAGRAM AND PARTS LOCATION (Pattern Side)	6
6. IC BLOCK DIAGRAMS	29
7. EXPLODED VIEW AND PARTS LIST	32
8. ELECTRICAL PARTS LIST	35

Please use this service manual with referring to the user guide (D.F.U) without fail.
修理の際は、必ず取扱説明書を準備し操作方法を確認の上作業を行ってください。

marantz®

MARANTZ DESIGN AND SERVICE

Using superior design and selected high grade components, **MARANTZ** company has created the ultimate in stereo sound. Only original **MARANTZ** parts can insure that your **MARANTZ** product will continue to perform to the specifications for which it is famous.

Parts for your **MARANTZ** equipment are generally available to our National Marantz Subsidiary or Agent.

ORDERING PARTS :

Parts can be ordered either by mail or by Fax.. In both cases, the correct part number has to be specified.

The following information must be supplied to eliminate delays in processing your order :

1. Complete address
2. Complete part numbers and quantities required
3. Description of parts
4. Model number for which part is required
5. Way of shipment
6. Signature : any order form or Fax. must be signed, otherwise such part order will be considered as null and void.

<p>USA MARANTZ AMERICA, INC. 440 MEDINAH ROAD ROSELLE, ILLINOIS 60172- 2330 USA PHONE : 630 - 307 - 3100 FAX : 630 - 307 - 2687</p>	<p>CANADA LENBROOK INDUSTRIES LIMITED 633 GRANITE COURT, PICKERING, ONTARIO L1W 3K1 CANADA PHONE : 416-831-6333 FAX : 416-831-6936</p>	<p>EUROPE MARANTZ EUROPE B.V. P.O.BOX 80002 BUILDING SFF2 5600 JB EINDHOVEN THE NETHERLANDS PHONE : +31 - 40 - 2732241 FAX : +31 - 40 - 2735578</p>
<p>PROFESSIONAL USA SUPERSCOPE TECHNOLOGIES, INC. MARANTZ PROFESSIONAL PRODUCTS 1000 CORPORATE BLVD., SUITE D AURORA, ILLINOIS 60504 USA PHONE : 630 - 820 - 4800 FAX : 630 - 820 - 8103</p>	<p>PROFESSIONAL CANADA TC ELECTRONICS CANADA LTD 540 FIRING AVE. BAIE D'URFÉ, QUEBEC H9X 3T2 CANADA PHONE : 514 - 457 - 4044 FAX : 514 - 457 - 5524</p>	<p>TRADING MARANTZ EUROPE B.V. P.O.BOX 80002 BUILDING SFF2 5600 JB EINDHOVEN THE NETHERLANDS PHONE : +31 - 40 - 2732241 FAX : +31 - 40 - 2735578</p>
<p>AUSTRALIA MARANTZ AUSTRALIA 3 Figtree Drive Australia Centre Homebush, NSW2140 AUSTRALIA PHONE : +61 2 742 8311 FAX : +61 2 764 3074</p>	<p>BRAZIL MARANTZ BRAZIL Caixa Postal 21462 CEP 04698-970 Sao Paulo, SP, BRAZIL PHONE : 0800 - 123123 (Discagem Direta Gratuita) FAX : +55 11 534. 8988</p>	<p>HONG KONG FORWARD INTERNATIONAL CORP.LTD. 15 TH FLOOR, REGENT CENTRE, 88 QUEEN'S ROAD, CENTRAL, H. K. PHONE : +852 521 - 0883 FAX : +852 521 - 7835</p>
<p>TAIWAN PAI-YUING CO., LTD. 6 TH FL NO, 148 SUNG KIANG ROAD, TAIPEI, 10429, TAIWAN R.O.C. PHONE : +886 (2) 5221304 - 8 FAX : +886 (2) 5630415</p>	<p>THAILAND MRZ STANDARD CO., LTD. 746 - 750 WANGBURAPA BANGKOK 10200 THAILAND PHONE : +66 2222 9181 FAX : +66 2225 8871</p>	<p>MALAYSIA WO KEE HONG ELECTRONICS SDN. BHD. NO. 1 02 JALAN SS 21/35, DAMANSARA UTAMA, 47400 PETALING JAYA SELANGOR DARUL EHSAN, MA LAYS IA PHONE : +60 3 - 7184666 FAX : +60 3 - 7173828</p>
<p>JAPAN Technical MARANTZ JAPAN INC. 35- 1, 7- chome, Sagami-cho Sagami-hara - shi, Kanagawa Japan PHONE : +81 427 44 7950 FAX : +81 427 48 0889</p>	<p style="text-align: center;">日本マランツ株式会社</p> <p>本社 〒228 神奈川県相模原市相模大野 7 - 35 - 1 営業本部 〒150 東京都渋谷区恵比寿南 1 - 11 - 9</p>	<p>SINGAPORE FORWARD MARKETING (SINGAPORE) PTE. LTD. 29, LENG KEE ROAD SINGAPORE I 59099, PHONE : +65 475 - 4555 FAX : +65 475 - 8623</p>

SHOCK, FIRE HAZARD SERVICE TEST :

CAUTION : After servicing this appliance and prior to returning to customer, measure the resistance between either primary AC cord connector pins (with unit NOT connected to AC mains and its Power switch ON), and the face or Front Panel of product and controls and chassis bottom.

Any resistance measurement less than 1 Megohms should cause unit to be repaired or corrected before AC power is applied, and verified before it is return to the user/customer.

Ref. UL Standard NO. 1492.

In case of difficulties, do not hesitate to contact the Technical Department at above mentioned address.

1. TECHNICAL SPECIFICATIONS

Output Level/Output Impedance

MAIN L/R, CENTER, SURROUND L/R	
1 KHz, 0 dB INPUT	0~3.5 V / 500 Ω
SUBWOOFER	
50 Hz, 0 dB INPUT	0~9 V / 500 Ω
Input Impedance (RF, COAXIAL)	75 Ω

Frequency Response

MAIN L/R, CENTER, SURROUND L/R (LARGE)	
20 Hz-20 KHz	±0.5dB

Filter Characteristics

MAIN L/R, CENTER, SURROUND L/R (SMALL)	
H.P.F.	fc=100 Hz, 12 dB/oct.
SUBWOOFER	
L.P.F.	fc=100 Hz, 24 dB/oct.

Total Harmonic Distortion

MAIN L/R, CENTER, SURROUND L/R (1 KHz)	0.01% or less
SUBWOOFER (50 Hz)	0.1% or less
Signal to Noise Ratio (IHF-A)	98 dB
Channel Separation (1 KHz)	80 dB
Power Consumption	30 W
AC OUTLET : UNSWITCHED	200 W max.
Dimensions (W/H/D)	17-3/8 in x 3-3/8 in x 10-7/8 in 444 mm x 85 mm x 303 mm(MAX)
Weight	9.4 lds. (4.2 kg.)

Specifications and components are subject to change without notice.
Overall performance will be maintained or improved.

Note : "RESET" operation is necessary to initialize the microprocessor (QL01) after every repair.

"RESET" procedures is follow.

Short "B-RST" terminals on the Side-B of PCB (P604) in a couple of seconds.

注意：修理後、マイコンを初期化するために、必ず、リセット操作をして下さい。

リセットの仕方は 以下の通りです。

電源OFFの状態、基板 (P604)のSide-BにあるB-RST端子を 2-3秒間ショートして下さい。

Manufactured under license from Dolby Laboratories Licensing Corporation. "Dolby", "AC-3", and the double-D symbol are trademarks of Dolby Laboratories Licensing Corporation. Copyright 1992 Dolby Laboratories, Inc. All rights reserved.

"Dolby", "AC-3" and the double-D symbol are trademarks of Dolby Laboratories Licensing Corporation.

2. TECHNICAL DESCRIPTION

This product is a "Dolby Digital (AC-3)" decoder. By connecting this product with a Dolby digital compatible component equipped with the Dolby AC-3 RF output such as a LD player, DVD player or DBS tuner, it will be capable of 5.1 CH (Front L/R, Rear L/R, Center and Sub-woofer) play.

This product is composed approximately of 5 blocks including the AC-3 decoder block (P604), DAC & crossover block (PD04), power supply block (P804), volume control block (PV04) and front key input block (PU04).

Signal path

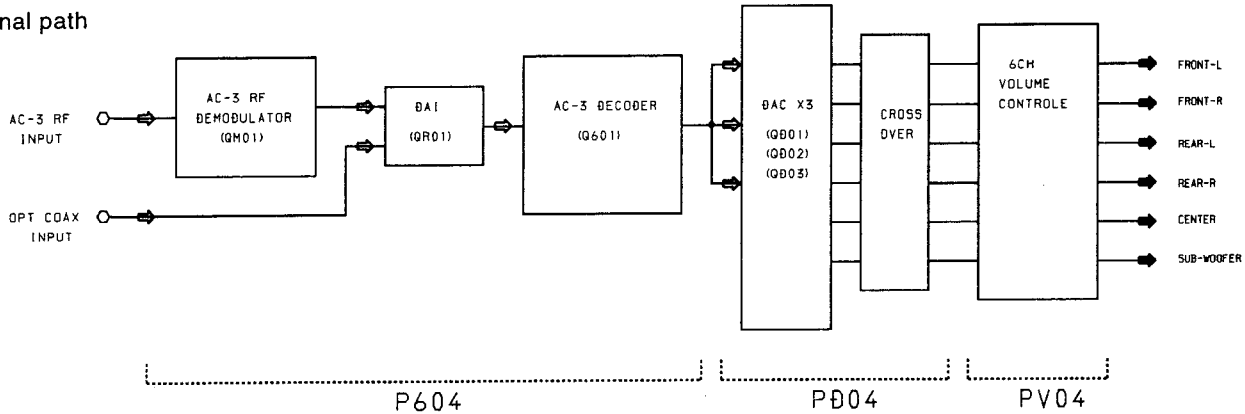

Figure 1

3. SIGNAL AND CIRCUIT DESCRIPTION

AC-3 RF

This signal is based on the Dolby Digital format for Laser Discs, and contains the AC-3 signal inserted in one of the analog audio channels of LD. See diagram below (Figure 2).

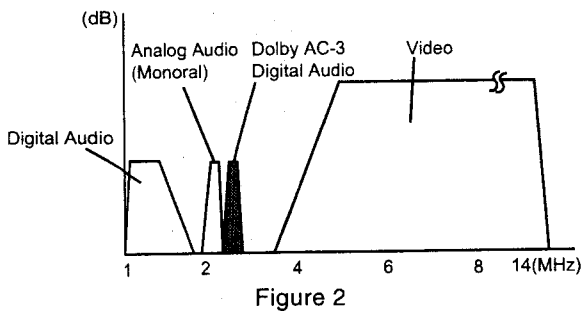

Figure 2

With this signal, the RF signal from the LD player (the signal read out with the pickup) is output as it is.

OPT/COAX (AC-3/PCM input)

This signal is based on an additional format for transmitting the AC-3 data through the conventional digital audio interface (SPDIF). In case of PCM signal, this signal contains the compressed AC-3 data overlapped in the audio data section. Similarly to the case of ROM data, whether the data is audio or non-audio is identified according to the status in the signal. This signal can be output from a DVD player, etc.

AC-3 RF modulator

This circuit extracts the AC-3 data band from the RF signal output from a LD player using a BPF and converts the extracted data into the digital signal in the SPDIF format by means of QPSK modulation.

DAI (Digital Audio Interface) receiver

This circuit extracts various clock and data signals from the signal input in the SPDIF format.

AC-3 decoder DSP

This circuit generates the 6-channel data (Front L/R, Rear L/R, Center and LFE) based on the data output from the DAI, and outputs the 6-channel data to the DAC as 3 sets of 2-channel data.

Crossover

This circuit divides the signal output of no more than 100 Hz according to the low-frequency reproduction capability of the speakers used by the user. It is controlled according to the switching of the HPF of each channel, mixing in the sub-woofer channel, etc.

2. 技術説明

本製品は”DOLBY DIGITAL (AC-3)”用DECODERである。
 DOLBY AC-3 RF出力付LD PLAYER, DVD PLAYER, DBSなどのDOLBY DIGITAL
 対応機器と接続する事により5.1CH(FRONT L/R, REAR L/R, CENTER,
 SUB-WOOFER)再生を行う。
 本製品は大きく分けるとAC-3 DECODER部(P604), DAC & CROSSOVER部
 (PD04), POWER SUPPLY部(P804), VOLUME CONTROL部(PV04), FRONT KEY
 入力部(PU04)など5のBLOCKにて構成される。信号経路図参照 Figure
 1

3. 各種信号及び回路BLOCK説明

AC-3 RF
 DOLBY DIGITALのLASER DISC用フォーマットであり、LDのANALOG
 音声部の片CHに、AC-3用の信号を入れたものである。図参照
 (Figure 2)
 LD PLAYERのRF信号(PICKUPの読み取り信号)がそのまま出力され
 てくる。

OPT/COAX(AC-3/PCM INPUT)
 従来のDIGITAL AUDIO INTERFACE (SPDIF)を用いてAC-3用DATAを送
 信する追加フォーマット。
 PCMの場合の音声DATA部にAC-3の圧縮DATAを乗せた信号である。
 ROM DATAの場合と同様に信号内のSTATUSにより、音声DATAか、非
 音声DATAかを識別する。
 DVD PLAYERなどが出力機能を持っている。

AC-3 RF DEMODULATOR
 LD PLAYERから出力されたRF信号内のAC-3 DATA帯域をBPFにより
 抽出し、QPSK変調によりSPDIFフォーマットのDIGITAL信号へ変換
 する。

DAI (DIGITAL AUDIO INTERFACE RECEIVER)
 SPDIFフォーマットにて入力された信号から各種CLOCK, DATAを
 抽出する。

AC-3 DECODE DSP
 DAIから出力されるDATAから6CH-DATA(FRONT L/R, REAR L/R,
 CENTER, LFE)を生成する。そして2CH-DATA x3としてDACへ出力す
 る。

CROSS OVER
 USERが使用するSPEAKERの低域再生能力によって100Hz以下の信
 号の出力分割を行う。各CHのHPFの切り替え、SUB-WOOFER CHへの
 MIX等によりコントロールされる。

4. BLOCK DIAGRAM

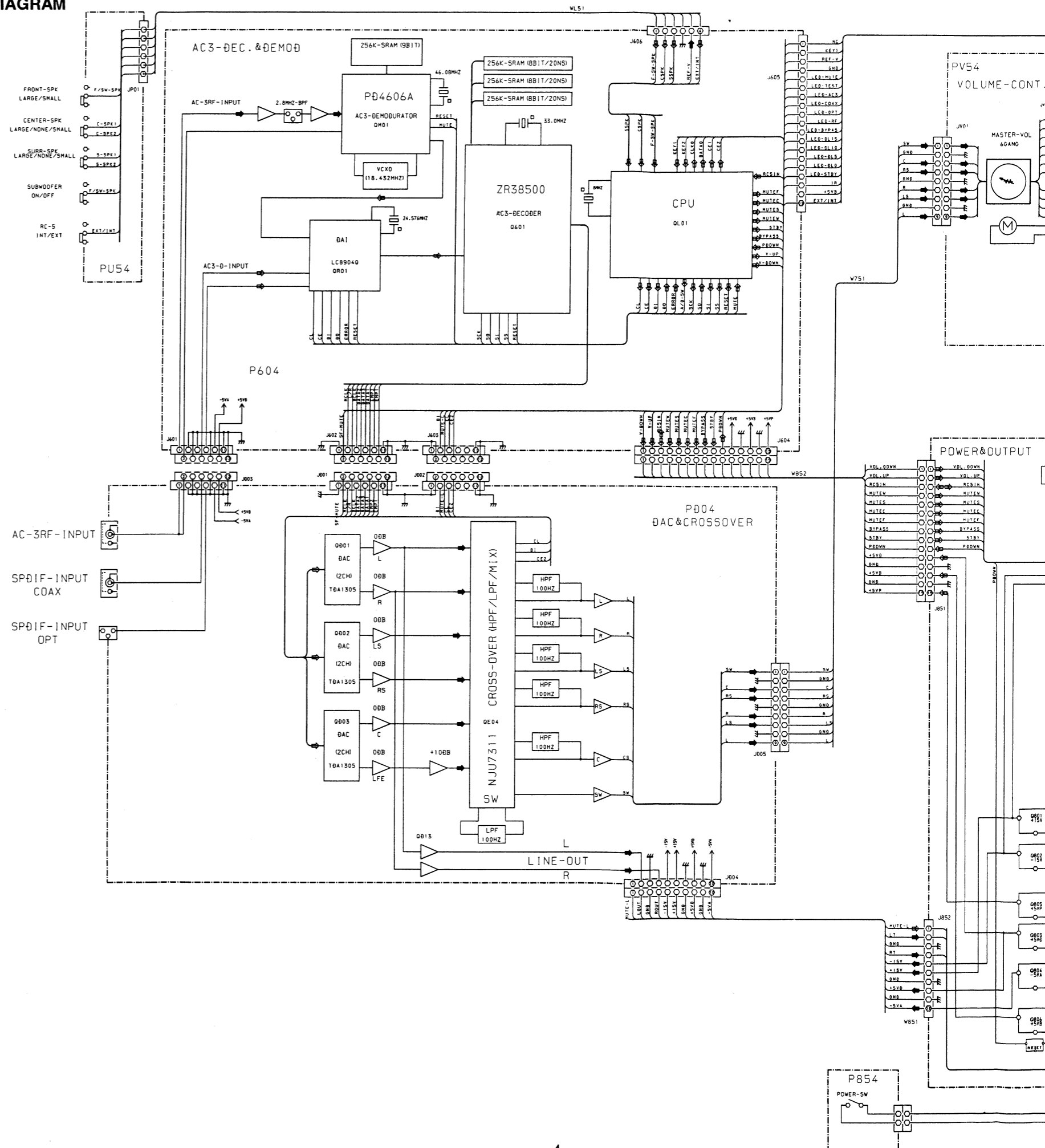

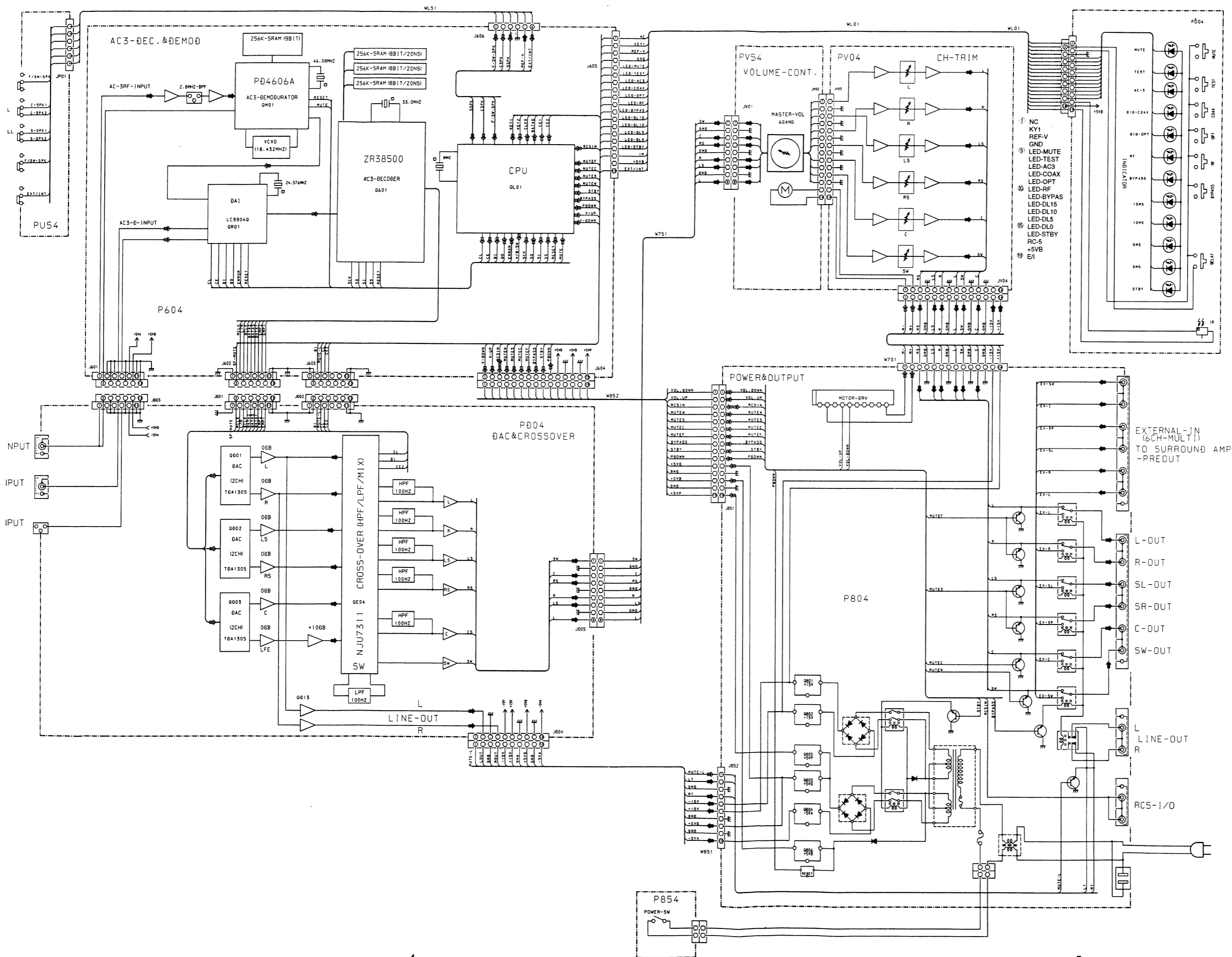

5. SCHEMATIC DIAGRAM AND PARTS LOCATION (Pattern Side)

SCHEMATIC DIAGRAMS (1)

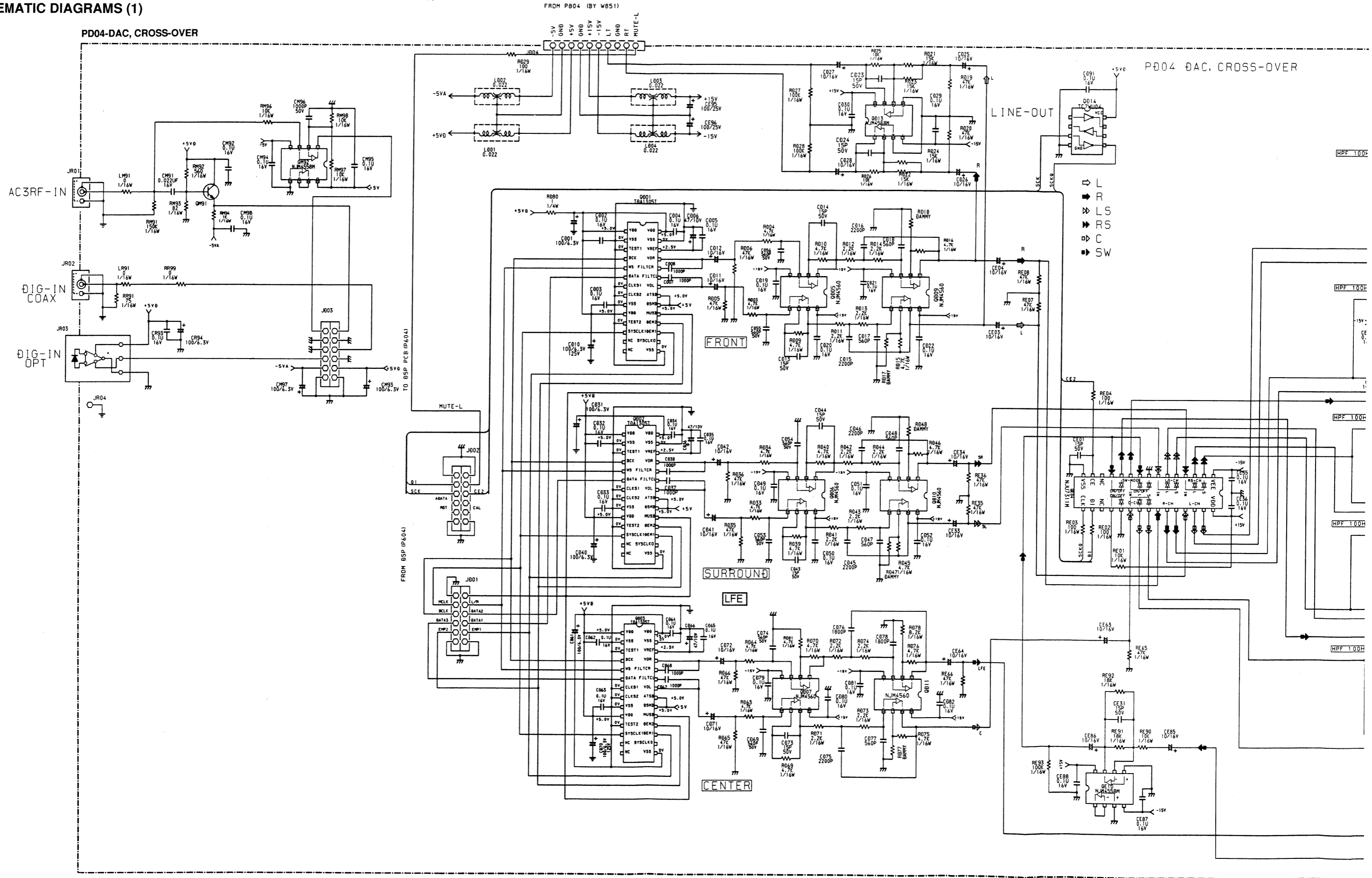

FROM P804 (BY W851)

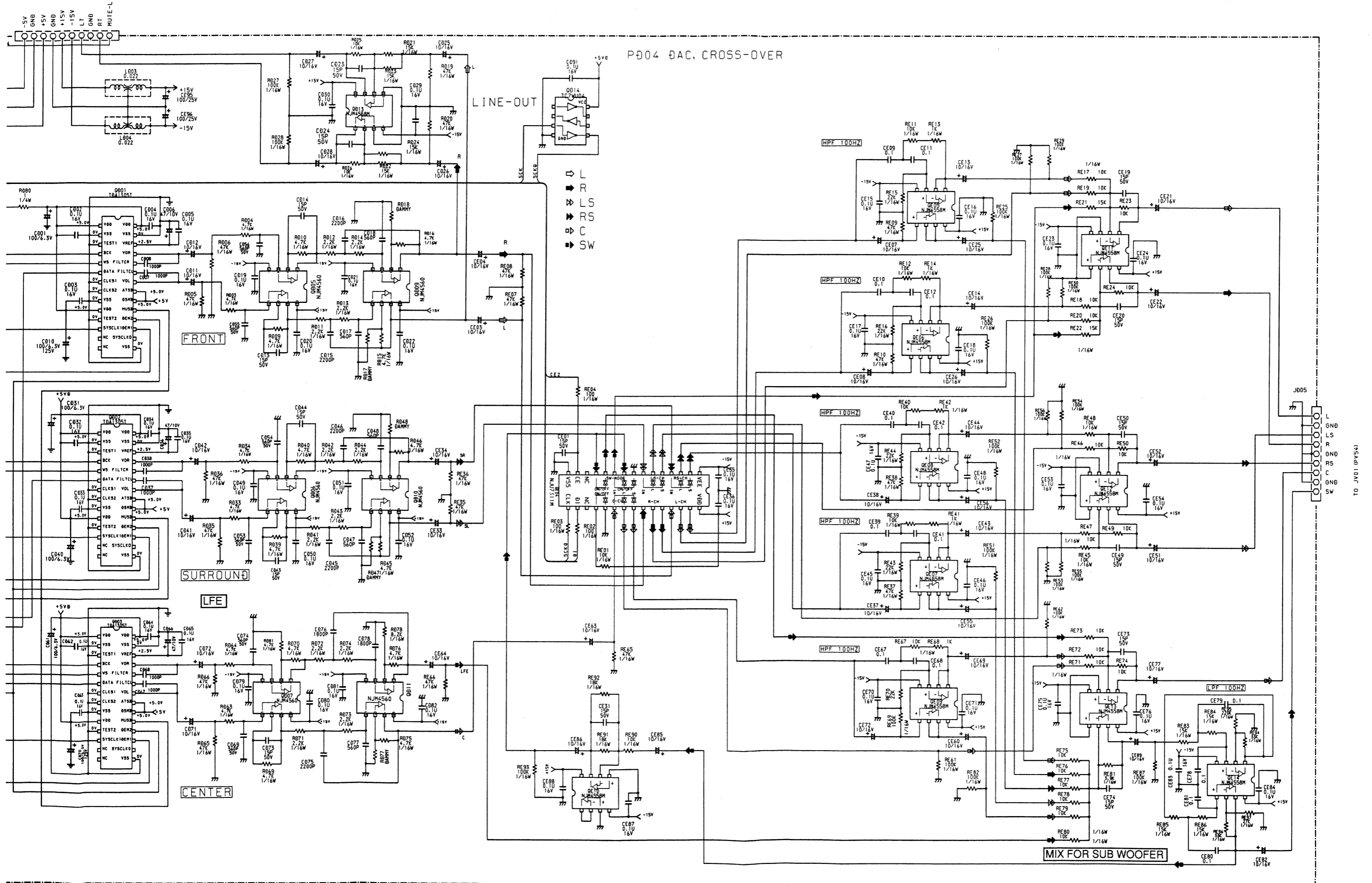

P804 DAC CROSS-OVER

LINE-OUT

FRONT

SURROUND

LFE

CENTER

MIX FOR SUB WOOFER

TO J005 (PVS4)

SCHEMATIC DIAGRAMS (2-1/2)

P604-AC-3 DECODER

AC-3 DECODER

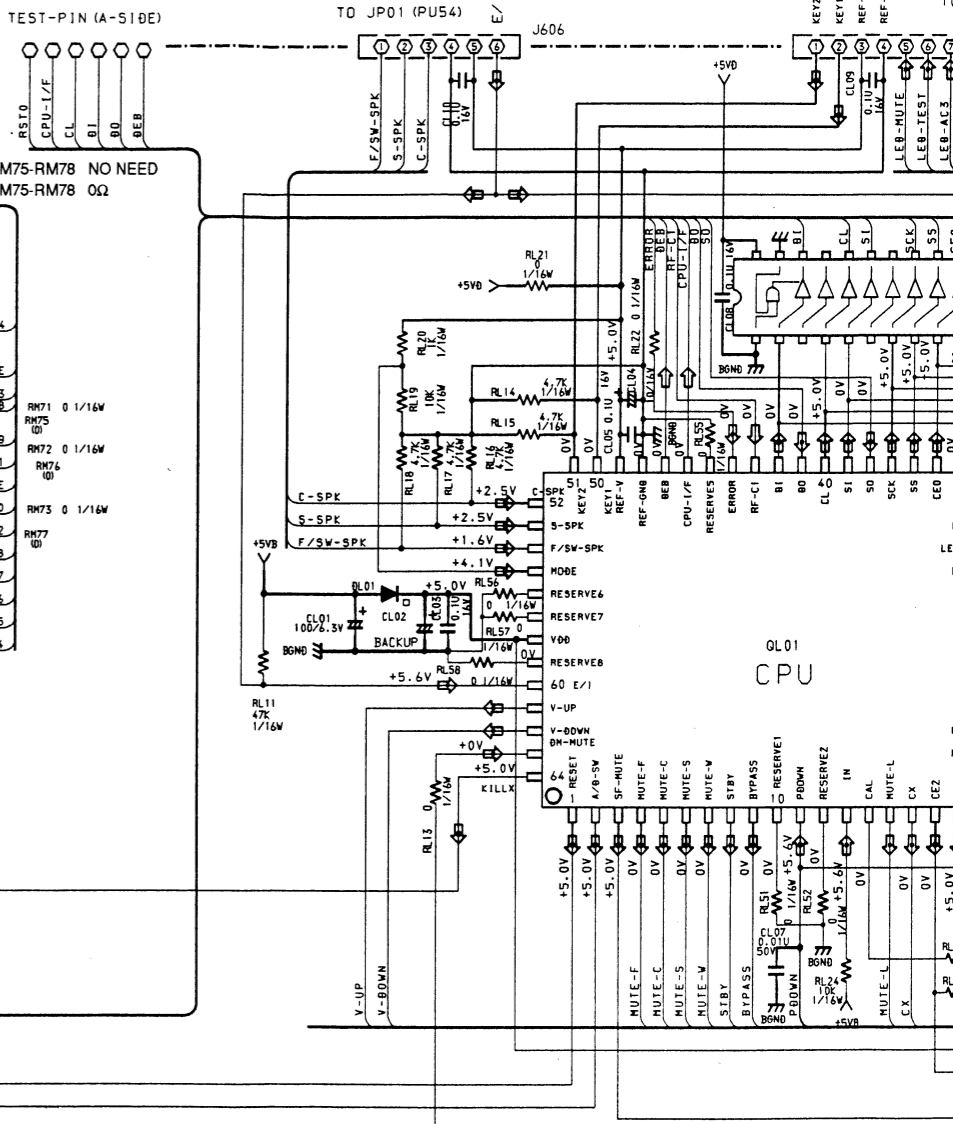
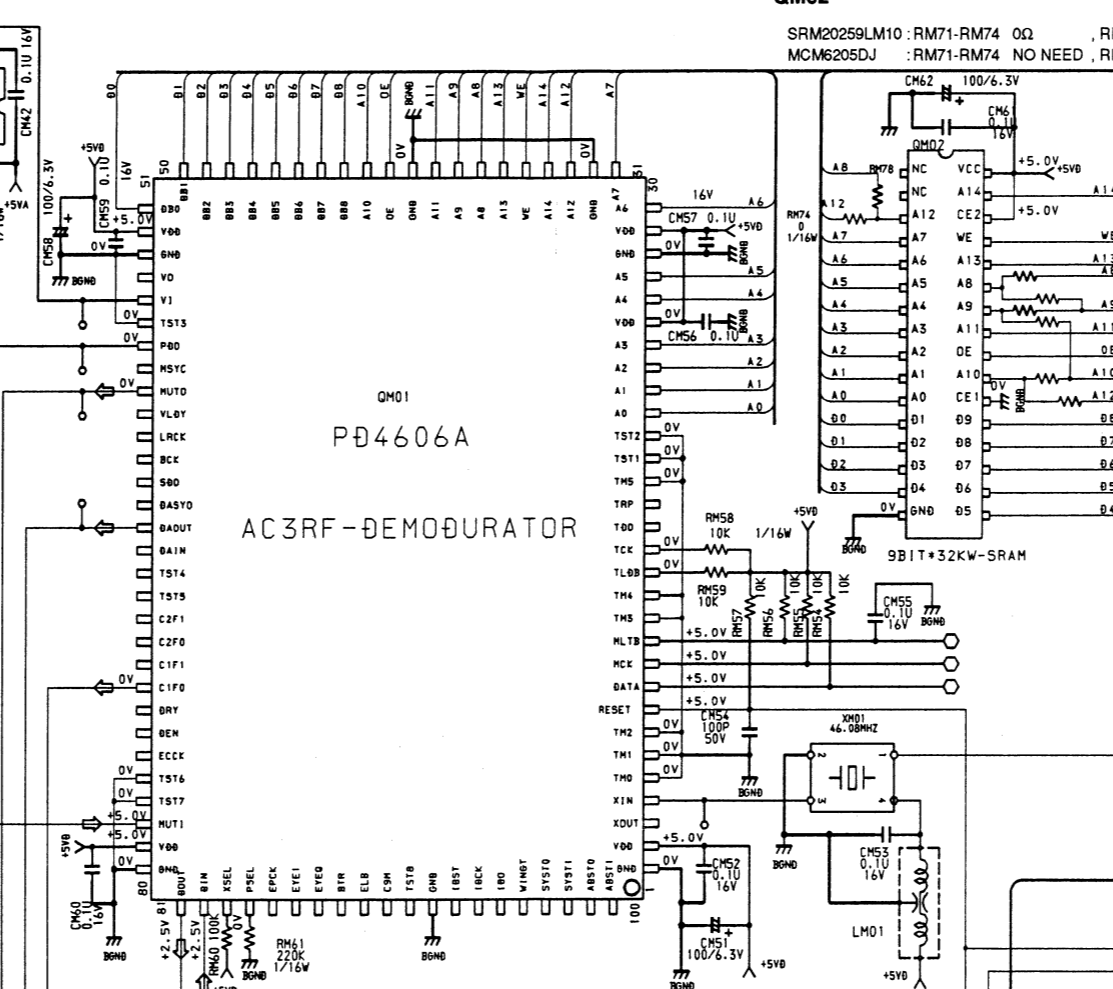
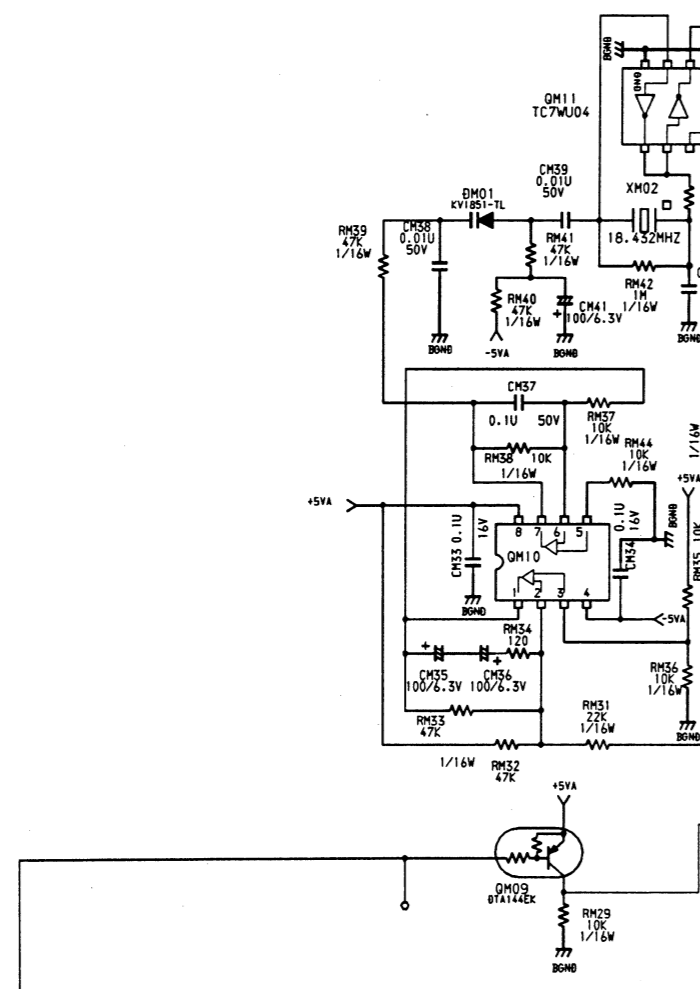

QM02
SRM20259LM10 : RM71-RM74 0Ω , RM75-RM78 NO NEED
MCM6205DJ : RM71-RM74 NO NEED , RM75-RM78 0Ω

(A)

(B)

SCHEMATIC DIAGRAMS (2-2/2)

P604-AC-3 DECODER

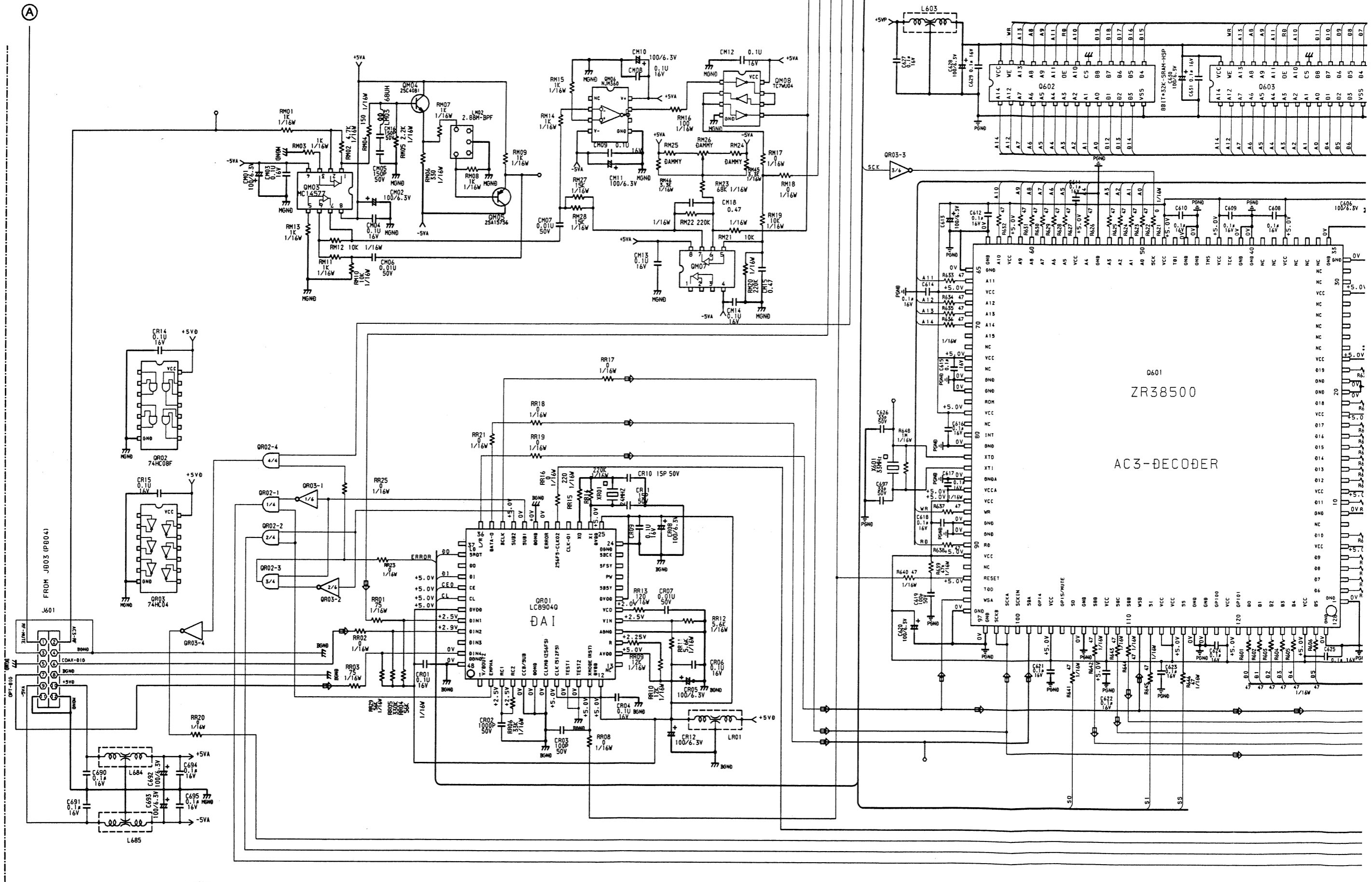

SCHEMATIC DIAGRAMS (3)

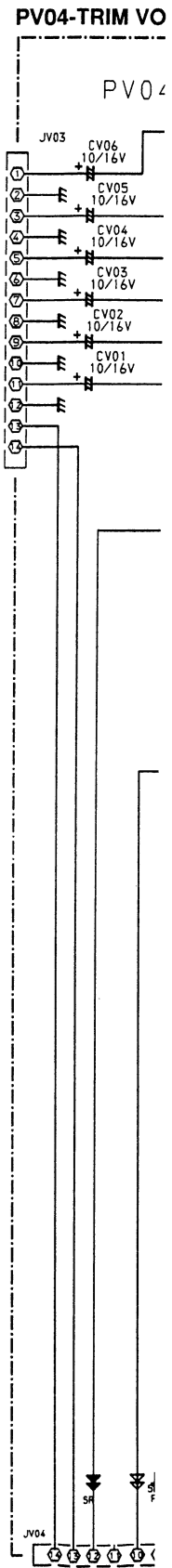
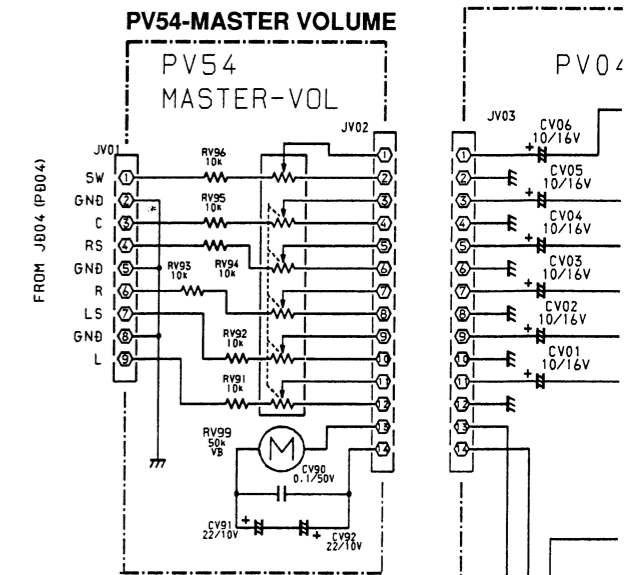
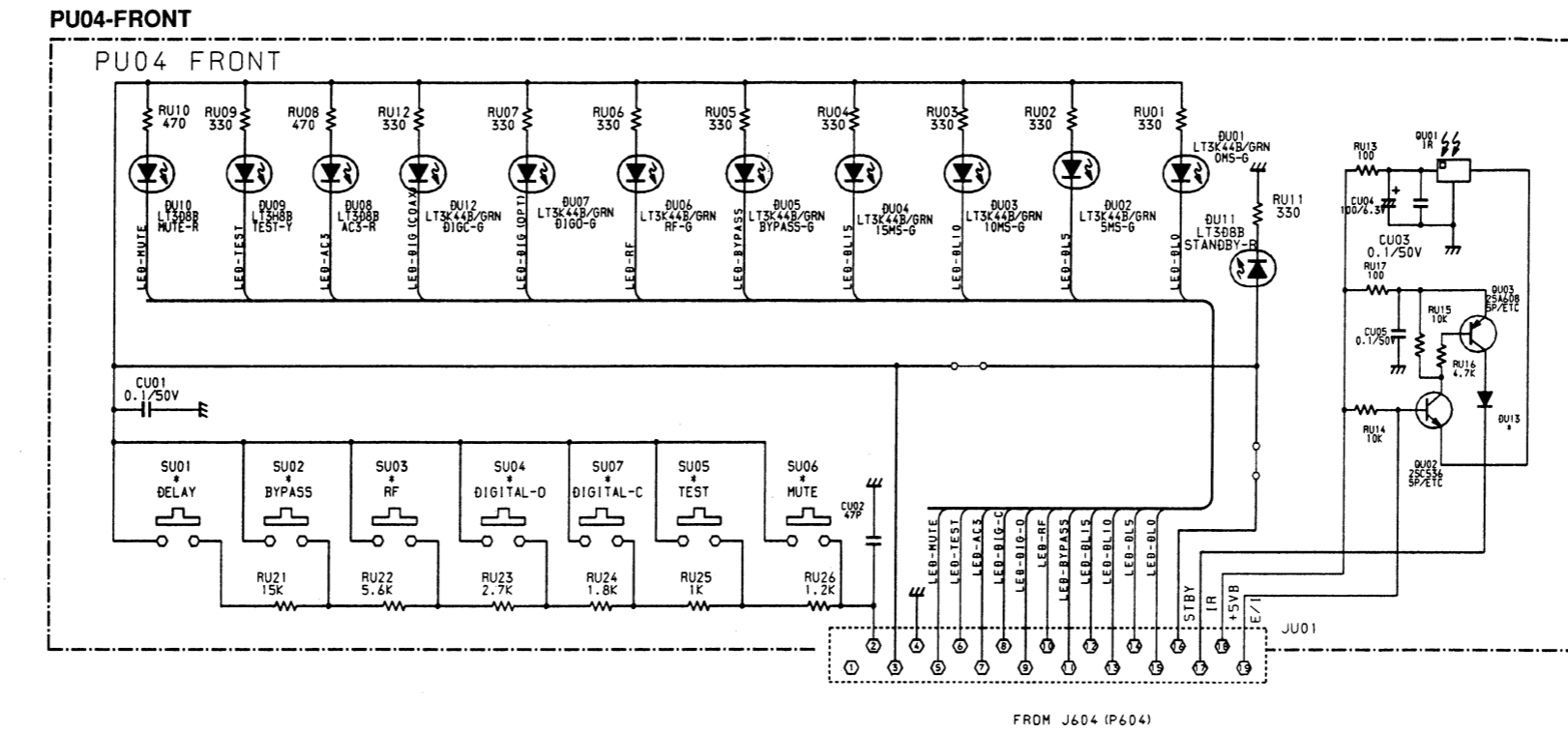
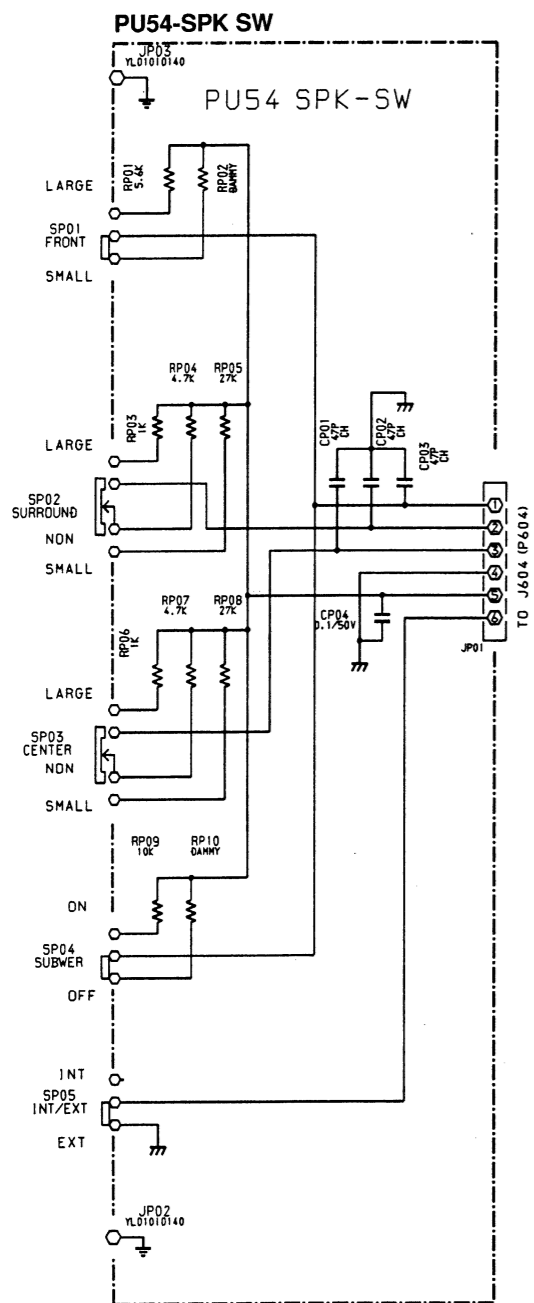

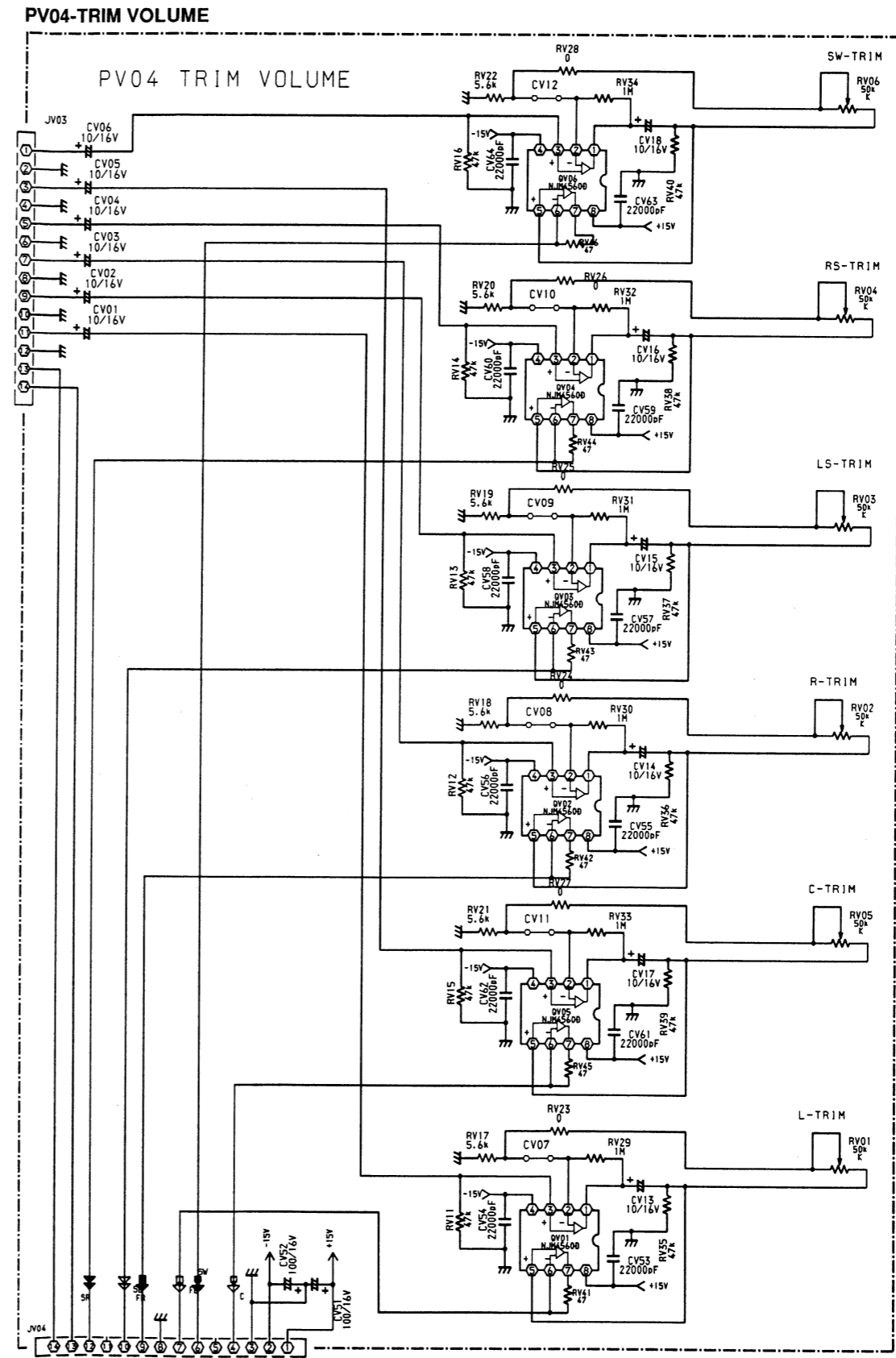
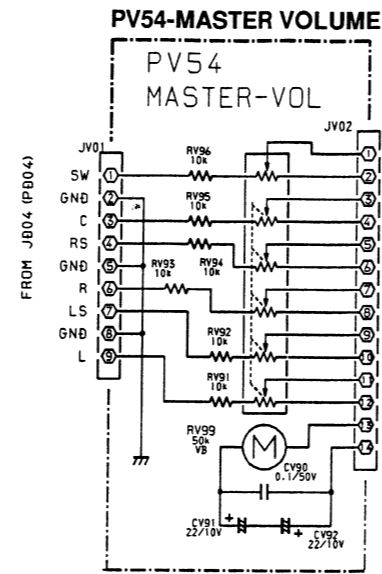
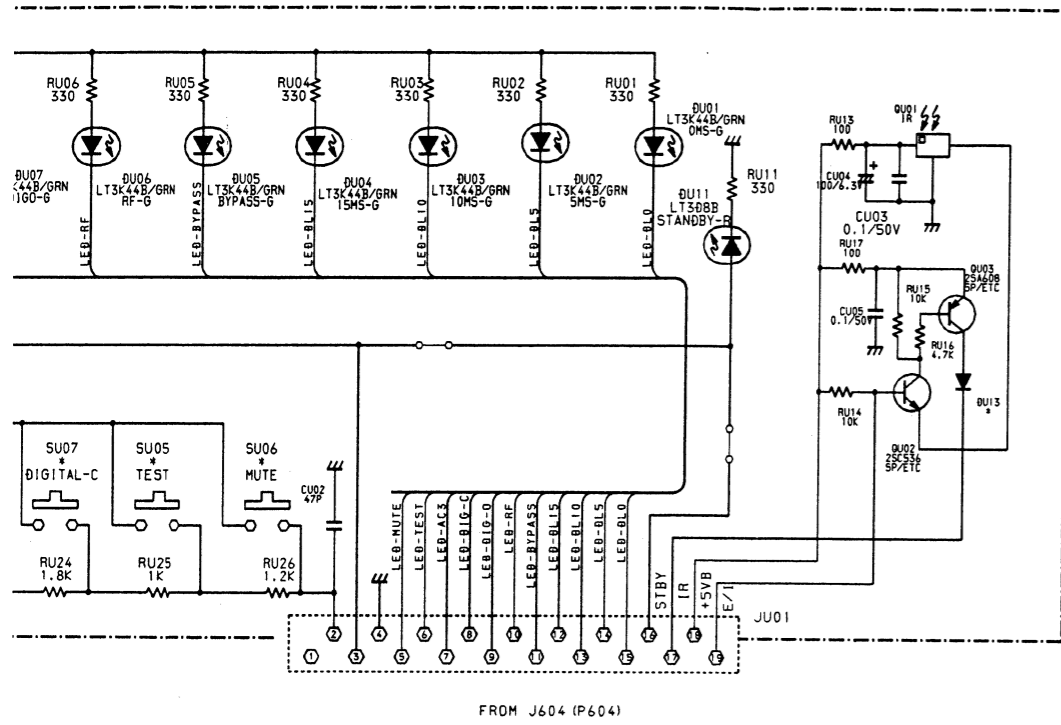

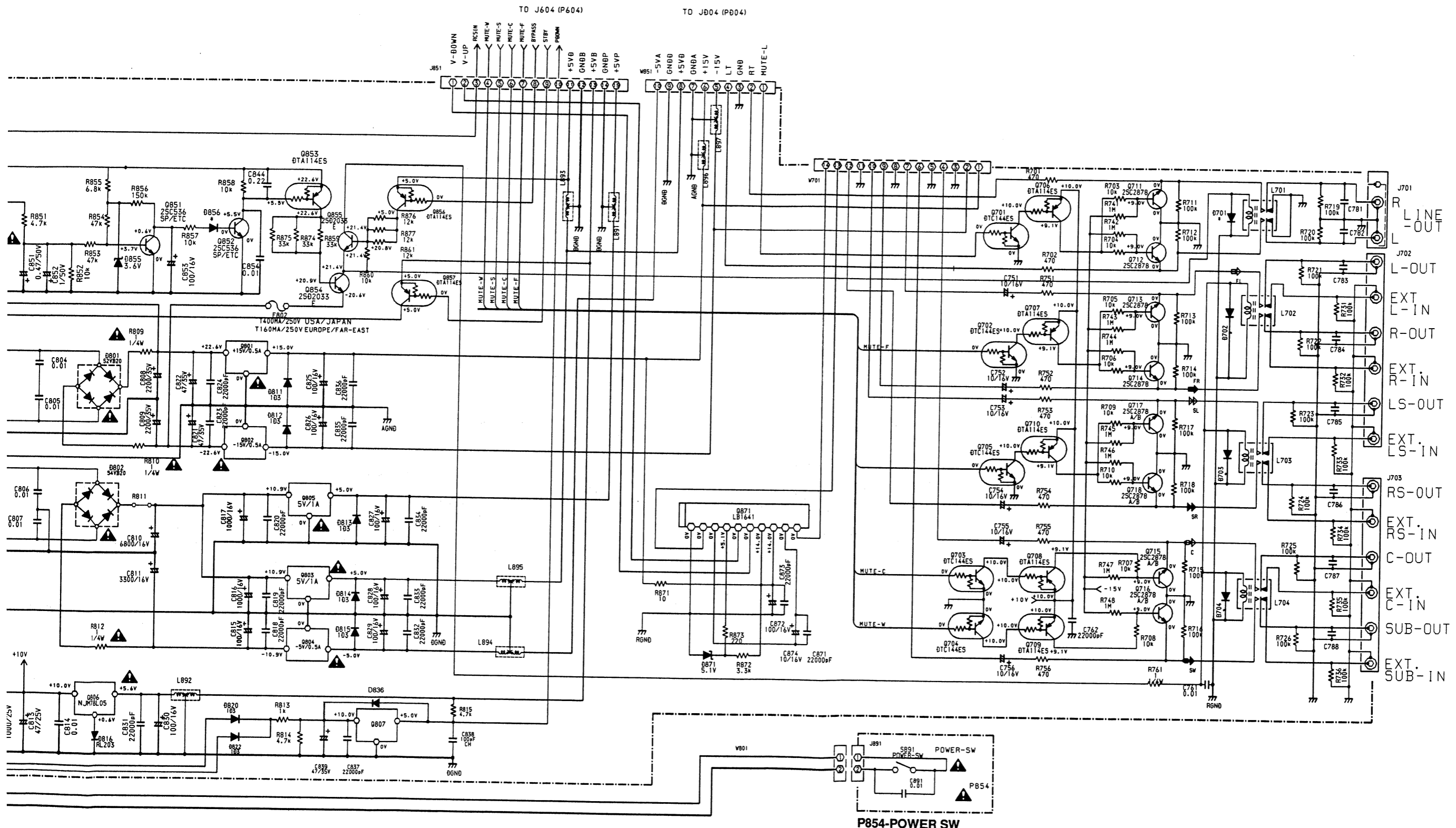

- J701 R LINE-OUT
- L701
- J702 L-OUT
- EXT L-IN
- R-OUT
- EXT R-IN
- LS-OUT
- EXT LS-IN
- J703 RS-OUT
- EXT RS-IN
- C-OUT
- EXT C-IN
- SUB-OUT
- EXT SUB-IN

P.C. BOARDS (1)

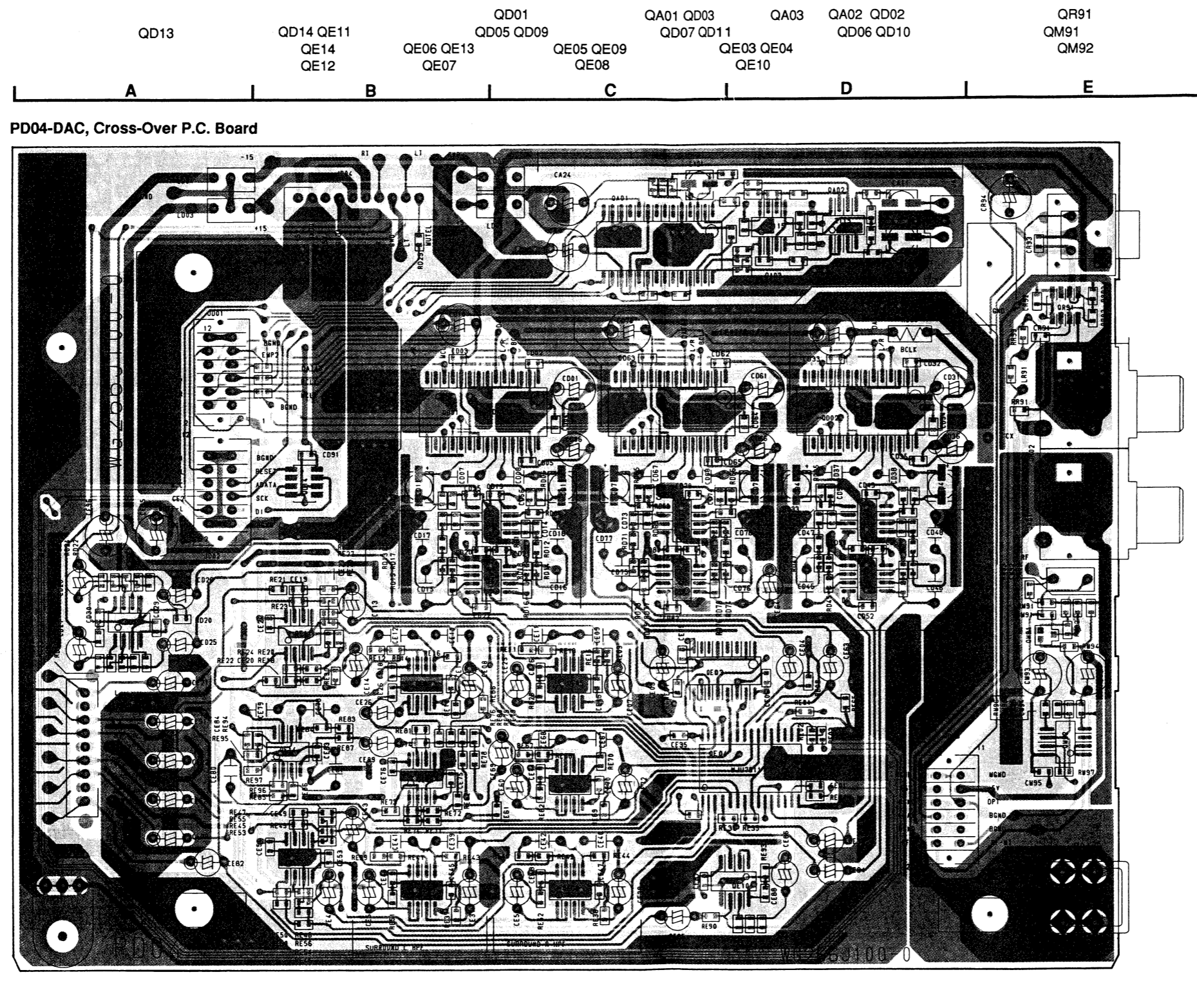

P.C. BOARDS (2)

QM01 QM09 QM11
 QL02
 QL04 QL08 QL05 QL06 QL07

QM10 QR03 QR02

QR04 QR01
 Q601

QM07 QM08 QM06 QM05 QM03 QM04
 Q602 QM02 QL01
 Q603
 Q604 QL09 QL03

P604-AC-3 Decoder P.C. Board

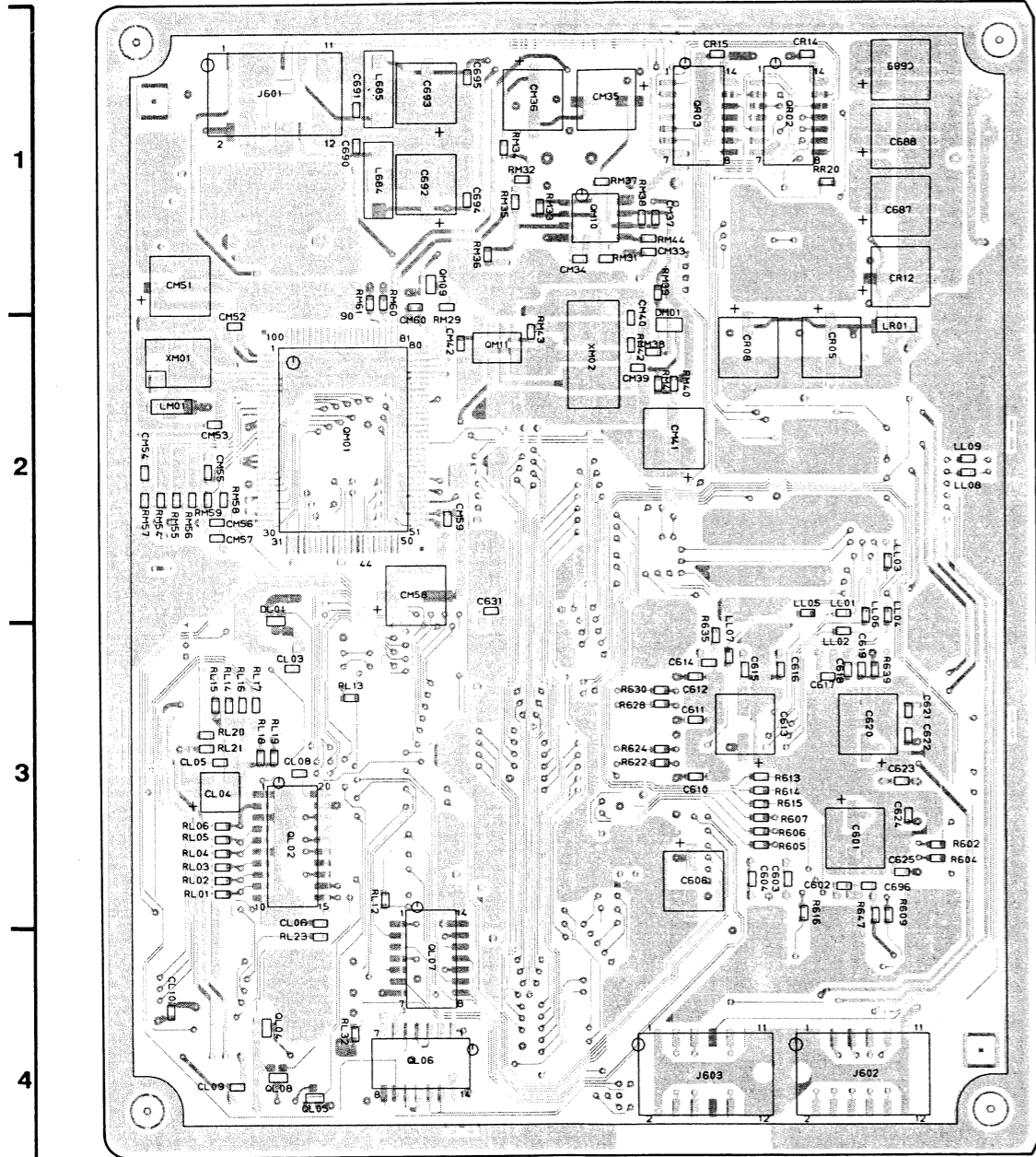

Side-A

P604

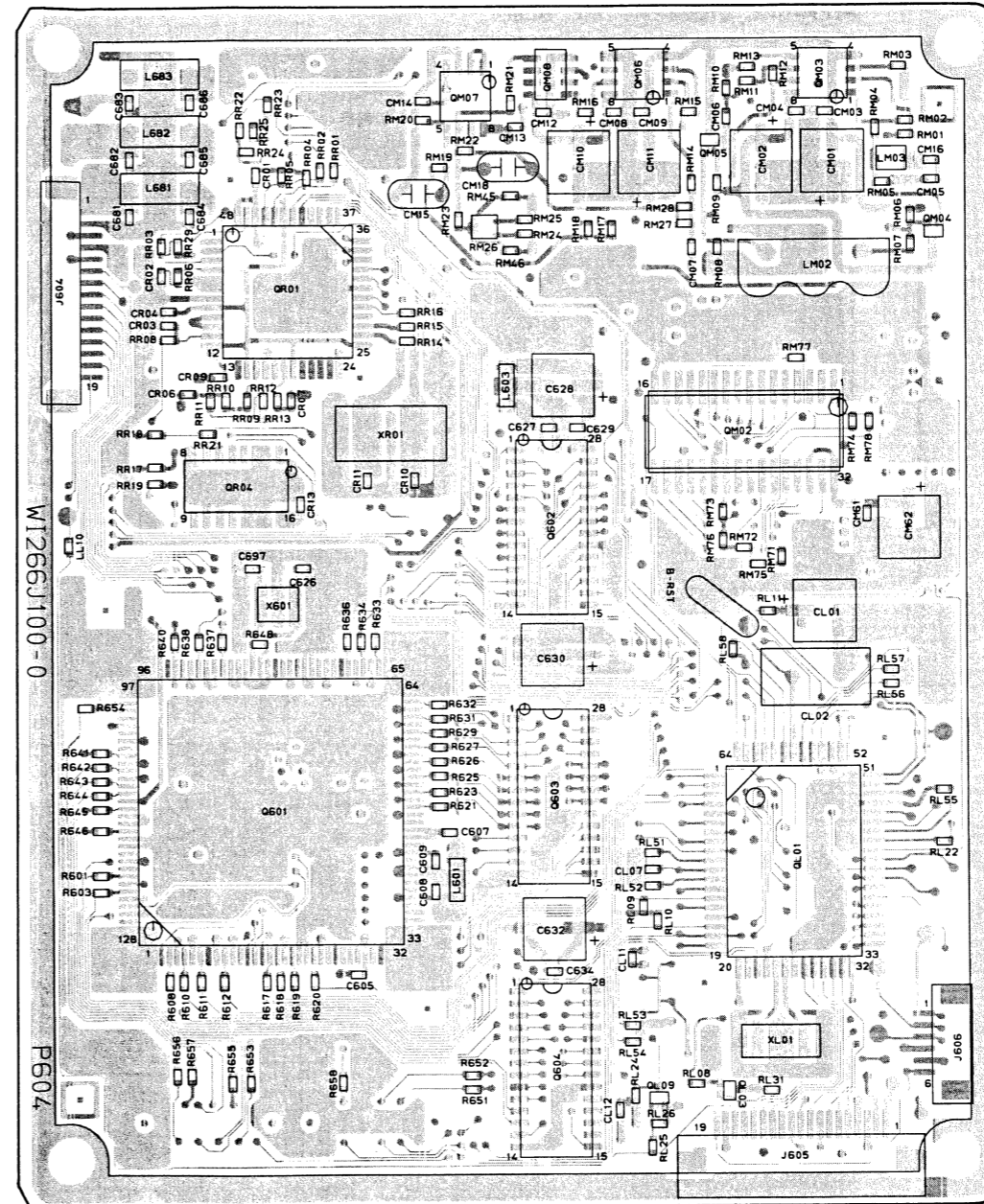

Side-B

P.C. BOARDS (3)

PU04-Front P.C. Board

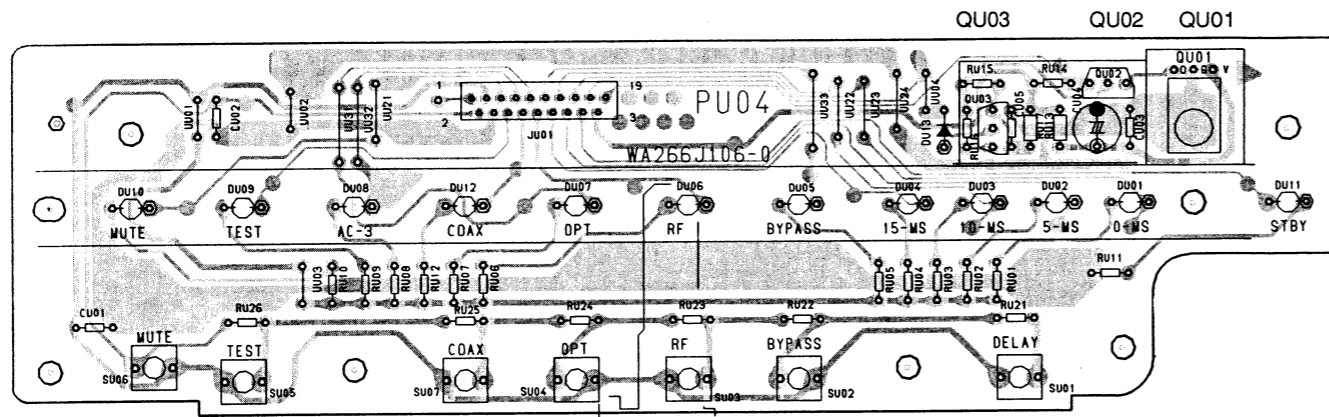

PU54-SPK SW P.C. Board

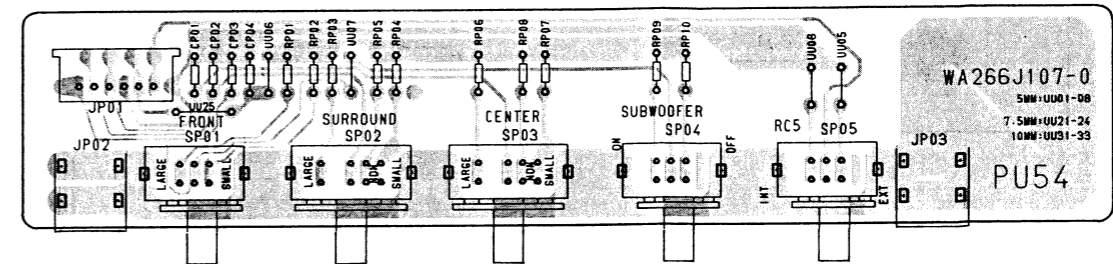

PV04-Trim Volume P.C. Board

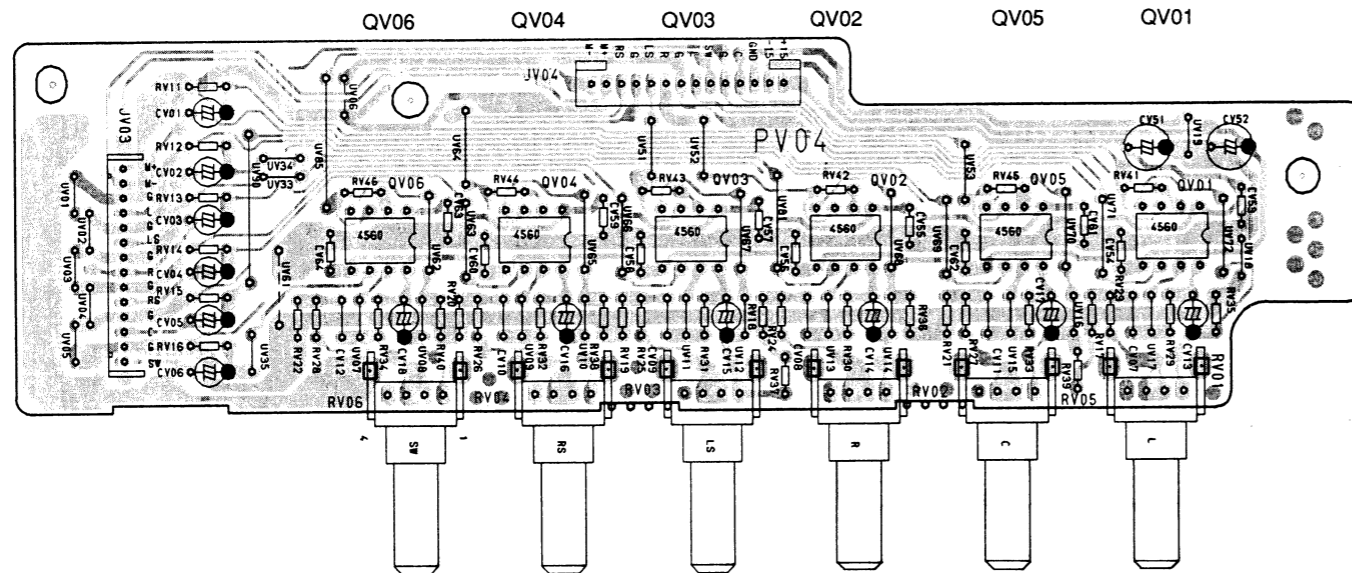

PV54-Master Volume P.C. Board

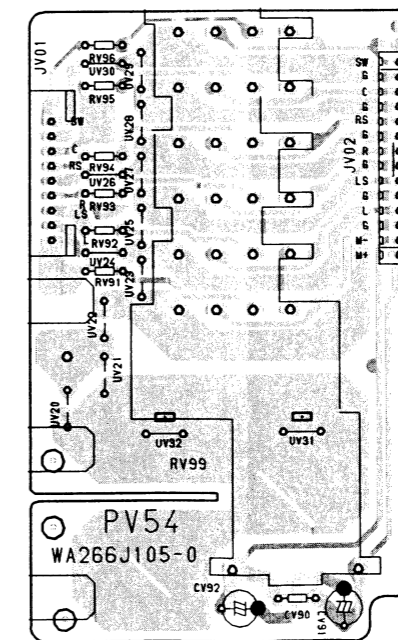

P.C. BOARDS (4)

P854-Power SW P.C. Board

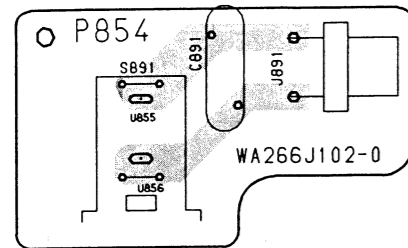

P884-Voltage Select P.C. Board [K VERSION]

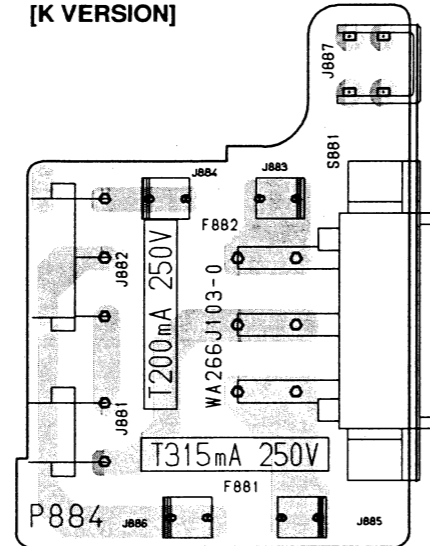

P804-Power P.C. Board

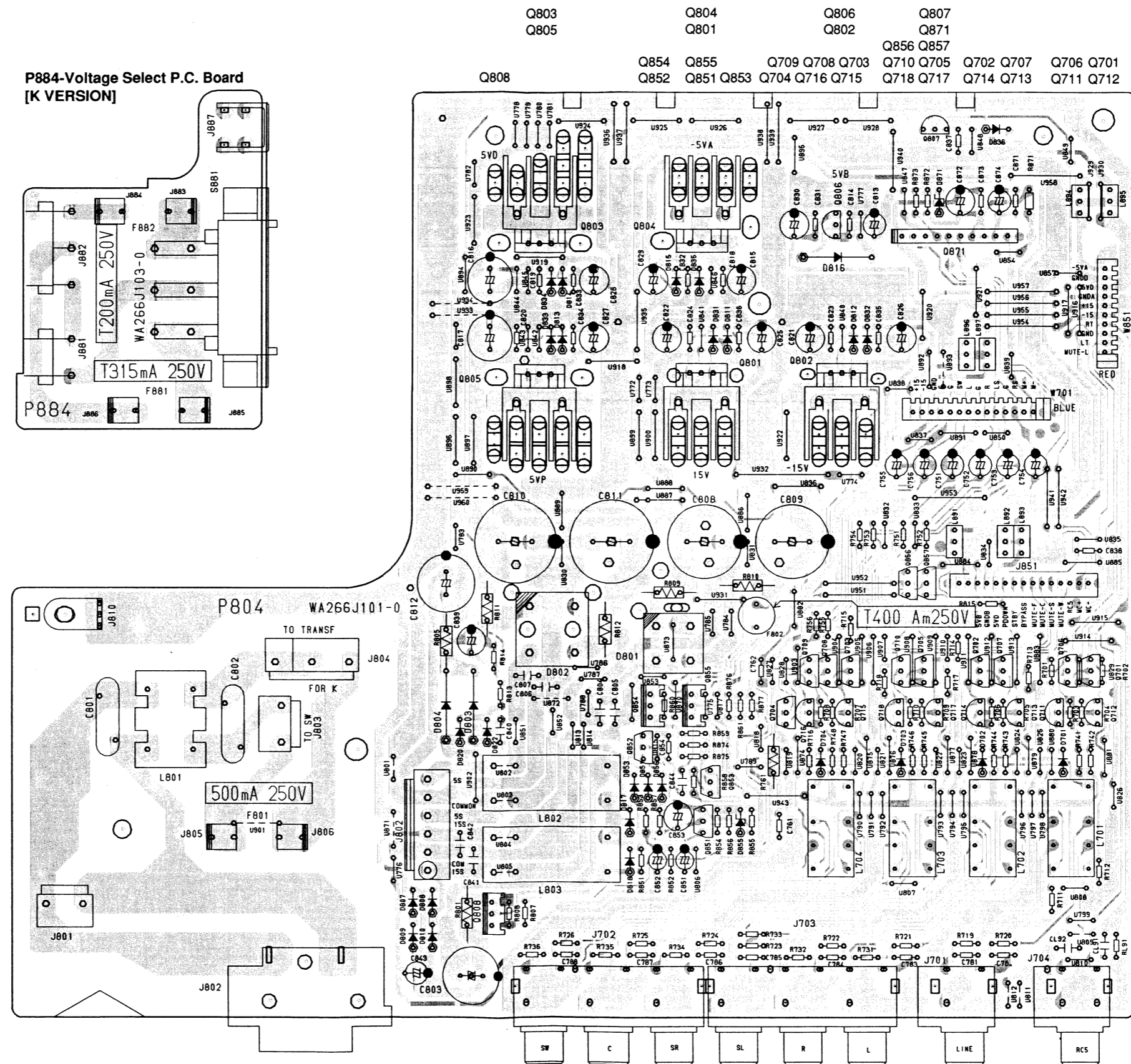

6. IC BLOCK DIAGRAMS

QM01 TERMINAL FUNCTIONS

Pin No.	Pin Name	I/O	Pin Function
1	GND	-	Ground (0V).
2	VDD	-	Power supply (+5V).
3	XOUT	O	X'tal oscillator output.
4	XIN	I	X'tal oscillator input.
5	TM0	I	IC test mode setting terminal. Usually no connection.
6	TM1	I	IC test mode setting terminal. Usually no connection.
7	TM2	I	IC test mode setting terminal. Usually no connection.
8	RESET	I	System reset terminal. Reset with "L". Goes "L" temporarily after power is turned ON.
9	DATA	I	Serial data input from CPU. (LSB first)
10	MCK	I	Serial clock input from CPU. Data is latched at the positive-going edge of the clock.
11	ML TB	I	CPU input latch. Latches the serial data (8 bits at a time) from the CPU into a register.
12	TM3	I	IC test mode setting terminal. Usually no connection.
13	TM4	I	IC test mode setting terminal. Usually no connection.
14	TLDB	I	Tag code load signal. "L" loads tag code in a 16-bit shift register.
15	TCK	I	Tag code output clock. Data is output at the positive-going edge of the clock.
16	TDO	O	Tag code serial data output. (MSB first)
17	TRP	O	Tag code update signal. Goes "H" when no error is found in the tag codes after the correction operation of each block.
18	TM5	I	IC test mode setting terminal. Usually no connection.
19	TSTIN1	I	IC test terminal. Usually no connection.
20	TSTIN2	I	IC test terminal. Usually no connection.
21	A0	O	External RAM address output. Address 0 (LSB).
22	A1	O	External RAM address output. Address 1.
23	A2	O	External RAM address output. Address 2.
24	A3	O	External RAM address output. Address 3.
25	VDD	-	Power supply (+5V).
26	A4	O	External RAM address output. Address 4.
27	A5	O	External RAM address output. Address 5.
28	GND	-	Ground (0V).
29	VDD	-	Power supply (+5V).
30	A6	O	External RAM address output. Address 6.
31	A7	O	External RAM address output. Address 7.
32	GND	-	Ground (0V).
33	A12	O	External RAM address output. Address 12.
34	A14	O	External RAM address output. Address 14 (MSB).
35	WEB	O	External RAM write enable output. "L" active.
36	A13	O	External RAM address output. Address 13.
37	A8	O	External RAM address output. Address 8.
38	A9	O	External RAM address output. Address 9.
39	A11	O	External RAM address output. Address 11.
40	GND	-	Ground (0V).
41	OEB	O	External RAM output enable output. "L" active.
42	A10	O	External RAM address output. Address 10.
43	DBP	I/O	External RAM data terminal. For use as the erasure pointer.
44	DB7	I/O	External RAM data terminal. Data path 7.
45	DB6	I/O	External RAM data terminal. Data path 6.
46	DB5	I/O	External RAM data terminal. Data path 5.
47	DB4	I/O	External RAM data terminal. Data path 4.
48	DB3	I/O	External RAM data terminal. Data path 3.
49	DB2	I/O	External RAM data terminal. Data path 2.
50	DB1	I/O	External RAM data terminal. Data path 1.
51	DB0	I/O	External RAM data terminal. Data path 0.
52	VDD	-	Power supply (+5V).
53	GND	-	Ground (0V).
54	V0	O	VCXO output.
55	V1	I	VCXO input.
56	TSTIN3	I	IC test terminal. Usually no connection.
57	PDO	O	Phase comparator output (3-state).
58	MSYC	O	"H" with AC-3 sync signal. For use in monitoring.
59	MUTO	O	Muting output. "H" for muting. Goes "H" when "MUT1 = H" or the AC-3 signal is out of sync.
60	VLDY	O	Validity flag output. "L" indicate correct data and "H" indicates a possibility of error.
61	LRCK	O	L/R channel switching clock. 48kHz. "H" for L CH.
62	BCK	O	Bit clock. 3.072MHz.
63	SDO	O	Serial data output.
64	DASYO	O	Digital output preamble B identification signal.
65	DAOUT	O	Digital output.
66	DAIN	I	Digital audio interface signal input. The digital output which has been processed inside the IC or the signal from "DAIN" is selected according to the internal register setting and output at "DAOUT".
67	TSTIN4	I	IC test terminal. Usually no connection.
68	TSTIN5	I	IC test terminal. Usually no connection.
69	C2F1	O	C2 correction error state indication. Output indicating where correction completed or not.
70	C2F0	O	C2 correction error state indication. Output indicating the number of errors in C2.

Pin No.	Pin Name	I/O	Pin Function
71	C1F1	O	C1 correction error state indication. Output indicating whether an error is present or not in C1.
72	C1F0	O	C1 correction error state indication. Output indicating the number of errors in C1.
73	DRY	O	Error corrector monitoring signal.
74	DEN	O	Error corrector monitoring signal.
75	ECCK	O	Error corrector clock. 576kHz.
76	TSTIN6	I	IC test terminal. Usually no connection.
77	TSTIN7	I	IC test terminal. Usually no connection.
78	MUT1	I	Muting input. "H" for muting.
79	VDD	-	Power supply (+5V).
80	GND	-	Ground (0V).
81	DOUT	O	QPSK inverted output.
82	DIN	I	QPSK signal input.
83	XSEL	I	X'tal select signal. "H" for using it.
84	PSEL	I	PLL select signal. "H" for using it.
85	EPCK	O	QPSK eye pattern clock. 288 kHz.
86	EYE1	O	Eye pattern output: Phase I.
87	EYEQ	O	Eye pattern output: Phase Q.
88	BTR	O	
89	ELB	O	
90	C9M	O	9.216MHz
91	TSTIN8	I	IC test terminal. Usually no connection.
92	GND	-	Ground (0V)
93	IDST	O	ID start position indication signal.
94	IDCK	O	ID signal sampling clock. Data changes at the negative-positive edge of the clock. 576kHz.
95	IDO	O	ID data output (MSB first).
96	WINGT	O	Goes "L" during search for the sync signal of the correction block.
97	SYSR0	O	Indicates the sync signal lock status of the correction block.
98	SYST1	O	Indicates the sync signal lock status of the correction block.
99	ADST0	O	Indicates the ID address continuity status of the correction block.
100	ADST1	O	Indicates the ID address continuity status of the correction block.

QM01 : PD4606A

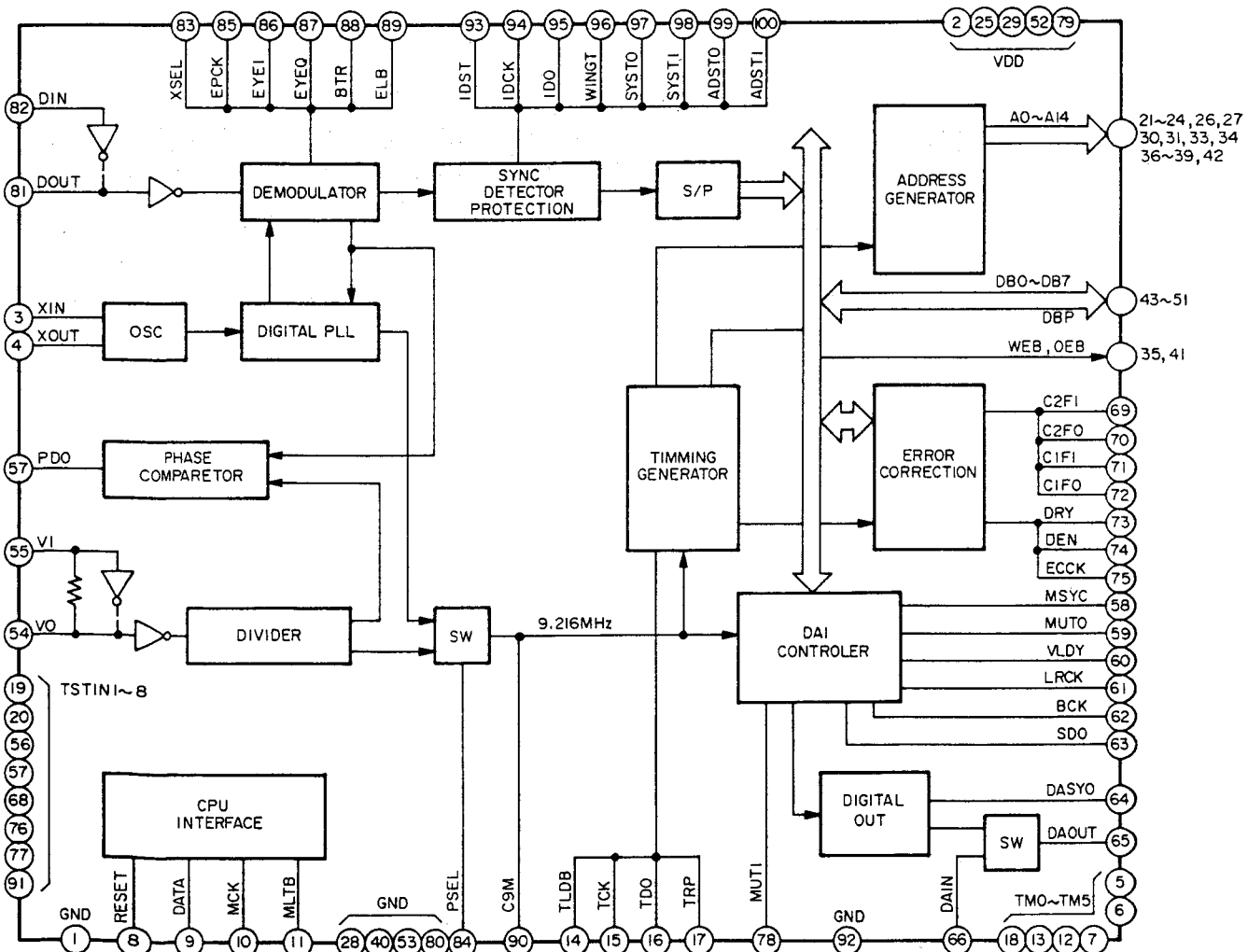

QL01 (CPU) TERMINAL FUNCTIONS

PIN No.	PORT NAME	I/O	FUNCTION
1	P76	RESET	O RESET OUTPUT to ZR38500,PD4606,LC8904Q L : RESET
2	P77	A/D-SW	O INPUT AUDIO DATA SELECT SW H : DAI L : ADC
3	P00	SF-MUTE	O Soft Mute OUTPUT to DAC L : MUTE H : normal
4	P01	MUTE-F	O Front Ch MUTE OUTPUT H : MUTE L : normal
5	P02	MUTE-C	O Center Ch MUTE OUTPUT H : MUTE L : normal
6	P03	MUTE-S	O Surround Ch MUTE OUTPUT H : MUTE L : normal
7	P04	MUTE-W	O SubWoofer Ch MUTE OUTPUT H : MUTE L : normal
8	P05	STBY	O STAND BY CONTROL OUTPUT H : standby L : on
9	P06	BYPASS	O Ext. AUDIO BYPASS CONTROLL OUTPUT H : Ext L : Int.
10	P07	N.C.	N.C.
11	P10/INT0	P-DOWN	I POWER-DOWN INPUT L : POWER-DOWN H : NORMALL
12	P11/INT1	N.C.	N.C.
13	P12/INT2	RC5INPUT	I RC-5 INPUT from IR & Ext. (ACTIVE : L)
14	P13/DVO	N.C.	N.C.
15	P14/PPG	MUTE-L	O MUTE OUT for LINE OUT H : MUTE L : normal
16	P15/TC2	LED-COAX	O DIGI-COAX INPUT SEL. LED H : LED ON L : OFF
17	P16	CE2	O CHIP ENABLE OUTPUT to NJU7311M
18	P17	LED-RF	O AC-3 RF INPUT SEL. LED H : LED ON L : OFF
19	P20/STOP	PDOWN	I for BACKUP MODE L : BACKUP H : normal
20	TEST	GND	I CONNECT TO GND
21	P21/XTI	N.C.	N.C.
22	P22/XTO	N.C.	N.C.
23	RESET	RST	I CPU RESET L : RESET H : normal
24	XIN	XTIN	I 8. 0MHz CERA-LOCK
25	XOUT	XTOUT	O 8. 0MHz CERA-LOCK
26	VSS	GND	GND
27	P30	LED-DL0	O S-DELAY 0ms LED L : LED ON H : OFF
28	P31	LED-DL5	O S-DELAY 5ms LED L : LED ON H : OFF
29	P32	LED-DL10	O S-DELAY 10ms LED L : LED ON H : OFF
30	P33	LED-DL15	O S-DELAY 15ms LED L : LED ON H : OFF
31	P34	LED-MUTE	O MUTE KEY MUTE LED H : LED ON L : OFF
32	P35	LED-TEST	O TEST TONE LED L : LED ON H : OFF
33	P36	LED-OPT	O INPUT FUNC. OPT LED L : LED ON H : OFF

PIN No.	PORT NAME	I/O	FUNCTION
34	P37	LED-AC3	O INPUT FUNC. AC3 LOCK LED L : LED ON H : OFF
35	P40	CE0	O CHIP ENABLE OUTPUT to DAI(LC8904Q)
36	P41	SS	O SPI SLAVE SELECT OUTPUT to ZR38500
37	P42/SCK1	SCK	O SPI CLOCK to ZR38500, & NJU7311
38	P43/SI1	SO	I SPI DATA from ZR38500
39	P44/SO1	Si	O SPI DATA to ZR38500 & NJU7311
40	P45/SCK2	CL	O CLOCK OUTPUT TO DAI(LC8904Q)
41	P46/SI2	DO	I DATA INPUT from DAI(LC8904Q)
42	P47/SO2	Di	O DATA OUTPUT to DAI(LC8904Q)
43	P50/INT3	N.C	I
44	P51/INT4	Error	I Error INPUT from DAI(LC8904Q) H : Error L : normal
45	P52	N.C.	N.C.
46	P53	N.C.	N.C.
47	P54	N.C	N.C
48	VASS	refGND	Int. A/D ref GND
49	VAREF	ref+5.6V	Int. A/D ref Vdd
50	P60/AIN0	KEY1	I FRONT KEY INPUT (7 KEYS)
51	P61/AIN1	KEY2	I Option Keys
52	P62/AIN2	C-SPK	I CENTER SPK MODE LARGE/SMALL/NONE A/D INPUT
53	P63/AIN3	S-SPK	I SURROUND SPK MODE LARGE/SMALL/NONE A/D INPUT
54	P64/AIN4	F/SW-SPK	I FRONT,SubW SPK MODE LARGE/SMALL, ON/OFF A/D INPUT
55	P65/AIN5	MODE	I CPU MODE SELECT (option mode) H : MZ L : HK
56	P66/AIN6	N.C	N.C
57	P67/AIN7	N.C	N.C
58	VDD	+5V	I +5V with BackUp Cap
59	P70	N.C.	N.C.
60	P71	Ext/Int	I RC-5 MODE SW H : Internal L : External
61	P72	V-UP	O VOLUME-CONT. : H L L : UP DOWN STOP
62	P73	V-DOWN	O VOLUME-CONT. : L H L
63	P74	DM-MUTE	I RF-MODULATOR-MUTE H : MUTE L : normal
64	P75	KILL-X	O OSC-STOP L : STOP H : OSC

QR01 : LC8904Q

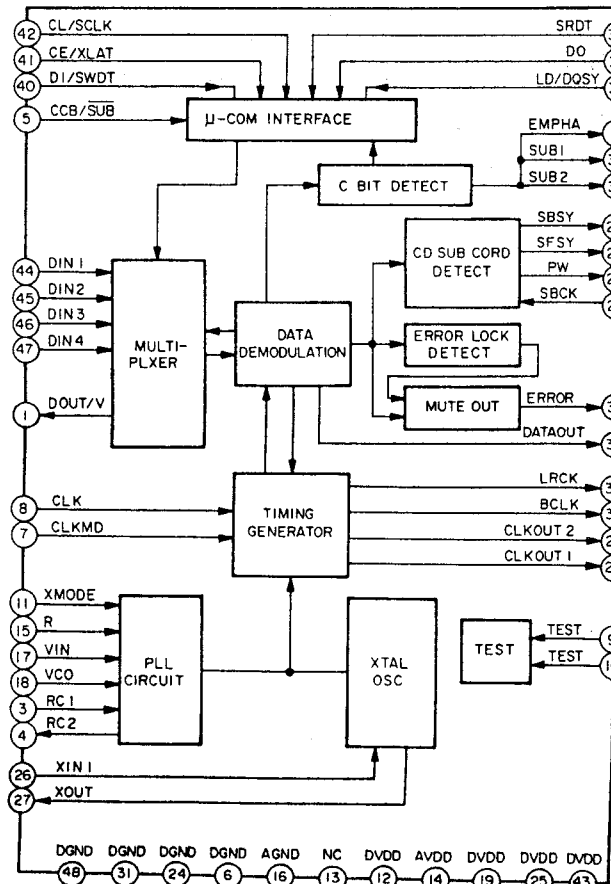

7. EXPLODED VIEW AND PARTS LIST

(VERS. :VERSION, U:U.S.A., F:JAPAN, K:FAR EAST, *:EUROPE)

POS. NO	VERS. COLOR	PART NO. (FOR PCS)	DESCRIPTION	PART NO. (MJI)
001B			FRONT PANEL, KIT (BLACK)	266J248500
002B		4822 459 04327	FRONT PANEL, (BLACK)	266J248010
003B		4822 450 10182	WINDOW,	266J158010
004B			BUSHING, MASTER VOLUME	266J259010
005B			BUSHING, TRIM BLACK	266J259020
006B			BUSHING, SIDE END BLACK	266J259030
009B			MASK, WINDOW	266J303010
010B			MASK, WINDOW MEJYUMU	266J303020
011B		4822 459 11172	BADGE, MZ BADGE BLACK	185J251010
012B		4822 413 41681	KNOB, MASTER BLACK	064J154080
013B		4822 410 62744	BUTTON, POWER BLACK	285K270010
014B		4822 404 21012	JOINT, POWER	025J125010
015B		4822 410 10708	KNOB, TRIM VOLUME BLACK	266J154010
016B			CHASSIS, FRONT METAL	266J105020
001D			LID, TOP COVER BLACK	198J257110
005D		4822 442 00552	SIDE PANEL, (L) BLACK	266J249010
006D		4822 442 00553	SIDE PANEL, (R) BLACK	266J249020
007D			BUSHING, SIDE PANEL	266J259050
006G		4822 462 42045	LEG, FRONT (GOLD)	183J057010
007G		4822 462 42048	LEG, REAR (GOLD)	183J057110
910G		4822 532 60948	BUSHING, AC CORD	450H259010
▲ L001	F		POWER TRANSF., FOR F	TS17205070
▲ L001	K		POWER TRANSF., FOR K	TS17205060
▲ L001	/02B		POWER TRANSF., FOR N	TS17205080
▲ L001	U		POWER TRANSF., FOR U	TS17205050
WL01			JUMPER LEAD, FFC19P P604-PU04 380MM	YU19380550
▲ W001	F		A.C POWER CORD, F OR E	YC01800800
▲ W001	/02B K		A.C POWER CORD, N	YC01800790
▲ W001	U		A.C POWER CORD, UL/CSA	YC01800780
			PACKING	
001S	F		PACKING CASE, BL	266J801010
002S	F		CUSHION, CUSHION(L, R)	266J809010
001T	F		USER MANUAL, DP870(F)	266J851110
001T	K		USER MANUAL, DP870(N)	266J851350
001T	/02B	4822 736 14644	USER MANUAL, DP870(N)	266J851310
001T	U		USER MANUAL, DP870(U)	266J851250
Z001	K	4822 267 31647	JACK, AC ADAPTER	YJ04001960

SYMBOL	STYLE	PARTS NAME	MARK	MATERIAL/FINISH
5128	⊕	+B.H.TAP TITE SCREW (B TYPE)	(M)	IRON/COPPER
5110	⊕	+B.H.M.SCREW	(U)	IRON/BLACK
5150	⊕	+F.H.TAP TITE SCREW (B TYPE)		

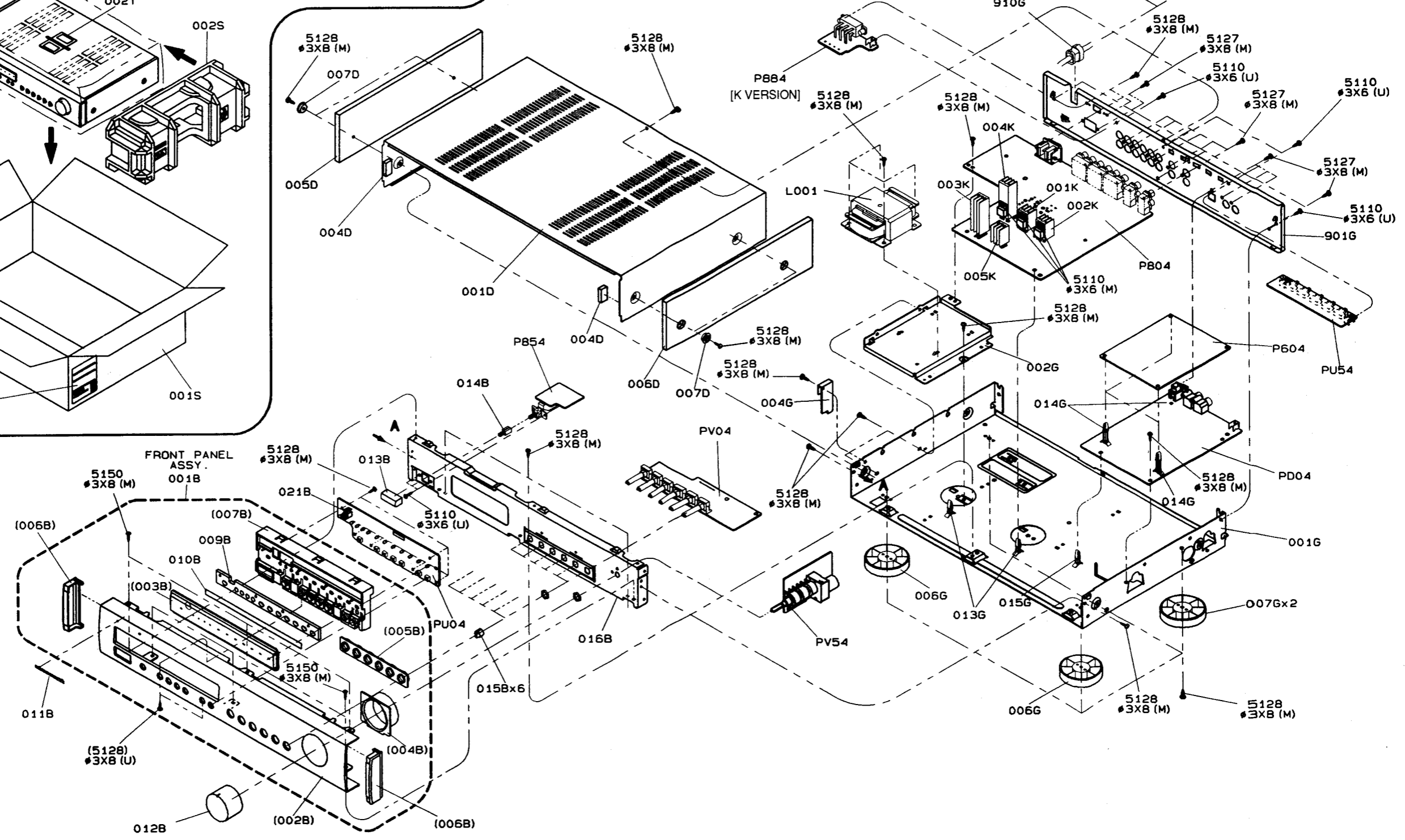
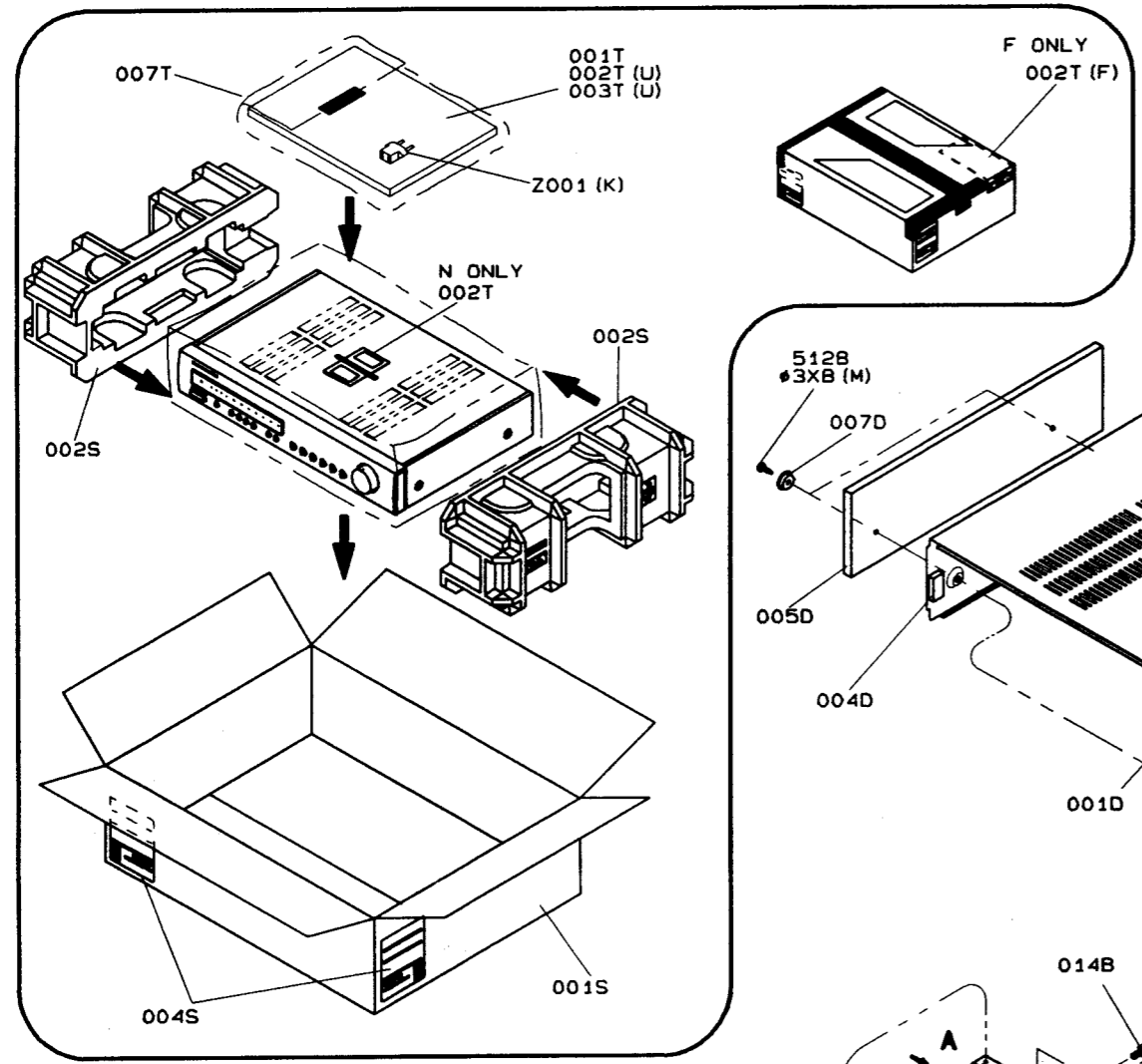

(VERS.:VERSION, U:U.S.A., F:JAPAN, K:FAR EAST, **:EUROPE)

POS. NO	VERS. COLOR	PART NO. (FOR PCS)	DESCRIPTION	PART NO. (MJ)
RL14				
		4822 051 30472	4.7KΩ ±5% 1/16W	NN05472610
RL19				
RL20		4822 051 30102	1KΩ ±5% 1/16W	NN05102610
RL21		4822 116 82487	0Ω 1/16W	NN05000610
RL22		4822 116 82487	0Ω 1/16W	NN05000610
RL23		4822 116 82487	0Ω 1/16W	NN05000610
RL24		4822 051 30103	10KΩ ±5% 1/16W	NN05103610
RL25		4822 051 30103	10KΩ ±5% 1/16W	NN05103610
RL26		4822 051 30473	47KΩ ±5% 1/16W	NN05473610
RL32		4822 051 30103	10KΩ ±5% 1/16W	NN05103610
RL51				
		4822 116 82487	0Ω 1/16W	NN05000610
RL58				
RM01		4822 051 30102	1KΩ ±5% 1/16W	NN05102610
RM02		4822 051 30472	4.7KΩ ±5% 1/16W	NN05472610
RM03		4822 051 30102	1KΩ ±5% 1/16W	NN05102610
RM04		4822 051 30151	150Ω ±5% 1/16W	NN05151610
RM05		4822 051 30222	2.2KΩ ±5% 1/16W	NN05222610
RM06		4822 051 30331	330Ω ±5% 1/16W	NN05331610
RM07		4822 051 30102	1KΩ ±5% 1/16W	NN05102610
RM08		4822 051 30102	1KΩ ±5% 1/16W	NN05102610
RM09		4822 051 30102	1KΩ ±5% 1/16W	NN05102610
RM10		4822 051 30103	10KΩ ±5% 1/16W	NN05103610
RM11		4822 051 30102	1KΩ ±5% 1/16W	NN05102610
RM12		4822 051 30103	10KΩ ±5% 1/16W	NN05103610
RM13		4822 051 30102	1KΩ ±5% 1/16W	NN05102610
RM14		4822 051 30102	1KΩ ±5% 1/16W	NN05102610
RM15		4822 051 30102	1KΩ ±5% 1/16W	NN05102610
RM16		4822 051 30101	100Ω ±5% 1/16W	NN05101610
RM17		4822 116 82487	0Ω ±5% 1/16W	NN05000610
RM19		4822 051 30103	10KΩ ±5% 1/16W	NN05103610
RM20		4822 051 30224	220KΩ ±5% 1/16W	NN05224610
RM21		4822 051 30103	10KΩ ±5% 1/16W	NN05103610
RM22		4822 051 30224	220KΩ ±5% 1/16W	NN05224610
RM23		4822 051 30683	68KΩ ±5% 1/16W	NN05683610
RM27		4822 051 30153	15KΩ ±5% 1/16W	NN05153610
RM28		4822 051 30153	15KΩ ±5% 1/16W	NN05153610
RM29		4822 051 30103	10KΩ ±5% 1/16W	NN05103610
RM31		4822 051 30223	22KΩ ±5% 1/16W	NN05223610
RM32		4822 051 30473	47KΩ ±5% 1/16W	NN05473610
RM33		4822 051 30473	47KΩ ±5% 1/16W	NN05473610
RM34		4822 116 83206	120Ω ±5% 1/16W	NN05121610
RM35				
		4822 051 30103	10KΩ ±5% 1/16W	NN05103610
RM38				
RM39		4822 051 30473	47KΩ ±5% 1/16W	NN05473610
RM40		4822 051 30473	47KΩ ±5% 1/16W	NN05473610
RM41		4822 051 30473	47KΩ ±5% 1/16W	NN05473610
RM42		4822 051 30105	1.0MΩ ±5% 1/16W	NN05105610
RM43		4822 116 82487	0Ω 1/16W	NN05000610
RM44		4822 051 30103	10KΩ ±5% 1/16W	NN05103610
RM45		4822 051 30332	3.3KΩ ±5% 1/16W	NN05332610
RM46		4822 051 30332	3.3KΩ ±5% 1/16W	NN05332610
RM54				
		4822 051 30103	10KΩ ±5% 1/16W	NN05103610
RM59				
RM60		4822 051 30104	100KΩ ±5% 1/16W	NN05104610
RM61		4822 051 30224	220KΩ ±5% 1/16W	NN05224610
RM75				
		4822 116 82487	0Ω 1/16W	NN05000610
RM78				

(VERS.:VERSION, U:U.S.A., F:JAPAN, K:FAR EAST, **:EUROPE)

POS. NO	VERS. COLOR	PART NO. (FOR PCS)	DESCRIPTION	PART NO. (MJ)
RR01		4822 051 30759	75Ω ±5% 1/16W	NN05750610
RR02		4822 126 13837	CER., 0.1 μF ±10% 10V	DK96104200
RR03		4822 051 30759	75Ω ±5% 1/16W	NN05750610
RR04		4822 116 83216	56KΩ ±5% 1/16W	NN05563610
RR05		4822 051 30334	330KΩ ±5% 1/16W	NN05334610
RR06		4822 051 30333	33KΩ ±5% 1/16W	NN05333610
RR08		4822 051 30479	47Ω ±5% 1/16W	NN05470610
RR09		4822 116 83208	12KΩ ±5% 1/16W	NN05123610
RR10		4822 116 83208	12KΩ ±5% 1/16W	NN05123610
RR11		4822 116 83215	5.6KΩ ±5% 1/16W	NN05562610
RR12		4822 116 83215	5.6KΩ ±5% 1/16W	NN05562610
RR13		4822 116 83206	120Ω ±5% 1/16W	NN05121610
RR14		4822 051 30224	220KΩ ±5% 1/16W	NN05224610
RR15				
		4822 116 82487	0Ω 1/16W	NN05000610
RR23				
RR25		4822 116 82487	0Ω 1/16W	NN05000610
RR29		4822 116 83216	56KΩ ±5% 1/16W	NN05563610
R601				
		4822 051 30479	47Ω ±5% 1/16W	NN05470610
R620				
R621		4822 116 82487	0Ω 1/16W	NN05000610
R622				
		4822 051 30479	47Ω ±5% 1/16W	NN05470610
R638				
R639		4822 051 30473	47KΩ ±5% 1/16W	NN05473610
R640				
		4822 051 30479	47Ω ±5% 1/16W	NN05470610
R646				
R647		4822 051 30473	47KΩ ±5% 1/16W	NN05473610
R648		4822 051 30105	1MΩ ±5% 1/16W	NN05105610
R651				
		4822 116 82487	0Ω 1/16W	NN05000610
R658				
LL01				
		4822 051 30101	100Ω ±5% 1/16W	NN05101610
LL09				
DL01		4822 130 83715	P604-SEMICONDUCTORS CHIP DIODE, 1SS301, DAN202U	HZ21005000
DM01		4822 130 10683	CHIP DIODE, KV1851-TL00	HZ40003420
QL01			MICROPROCESSOR, TMP87PH40AF	HU266JT02F
QL02		4822 209 14872	IC, 74HC541(SOP)	HC754100R0
QL03		4822 130 60856	DIG.TRS., DTC144EC	BA20021210
QL04		4822 130 60856	DIG.TRS., DTC144EC	BA20021210
QL05		4822 130 60856	DIG.TRS., DTC144EC	BA20021210
QL06		4822 209 30426	IC, CMOS 74HC00 FLAT	HC700000Z0
QL07		4822 209 31929	IC, OR-GATE 74HC32	HC703200Z0
QL08		4822 130 60856	DIG.TRS., DTC144EC	BA20021210
QL09			CHIP TR., 2SC4081 (Q, R) 2SC4116 (Y, GR)	HX300012A0
QM01		4822 209 14884	IC, PD4606A AC-3 RF DEMO.	HC10015660
QM02			IC, MCM6205DJ 9X32K SRAM <35NS	HC10081000
QM03		4822 209 14876	IC, MC14577BF(SOP)	HC10065170
QM04			CHIP TR., 2SC4081 (Q, R) 2SC4116 (Y, GR)	HX300012A0

(VERS.:VERSION, U:U.S.A., F:JAPAN, K:FAR EAST, **:EUROPE)

POS. NO	VERS. COLOR	PART NO. (FOR PCS)	DESCRIPTION	PART NO. (MJ)
QM05		4822 130 10698	CHIP TR., 2SA1586 (Y, GR) 2SA1576A (Q, R)	HX100012A0
QM06		4822 209 14877	IC, NJM360M(SOP)	HC10180090
QM07		4822 209 83357	IC, NJM4560M	HC10029090
QM08		4822 209 32442	IC, TC7WU04F	HC000305K0
QM09		4822 130 61199	DIG.TR.S., DTA144EU	BA10014210
QM10		4822 209 83357	IC, NJM4560M	HC10029090
QM11		4822 209 32442	IC, TC7WU04F	HC000305K0
QR01		4822 209 14863	IC, LC8904Q DIGI. AUDIO I/F	HC10372030
QR02		4822 209 63379	IC, 74HC08 FLAT	HC700800Z0
QR03		5322 209 73187	IC, 74HC04 FLAT	HC700400R0
Q601		4822 209 14882	IC, ZR38500-VER.3 AC-3 DECODER	HC10020990
Q602				
I		4822 209 14864	IC, M628032-20EI	HC10076000
Q604			8X32K SRAM <35NS (SOJ)	
			P604-MISCELLANEOUS	
J601			JACK, TKC-G12X-E1	YJ06031000
J602			JACK, TKC-G12X-E1	YJ06031000
J603			JACK, TKC-G12X-E1	YJ06031000
J604			JACK, 53261-1510 1.25MM	YJ07006850
J605			JACK, 006200-197-032800	YJ07006400
J606			JACK, 53261-0610 1.25MM	YJ07006760
LL01				
I		4822 051 30101	CHIP, 100Q $\pm 5\%$ 1/16W	NN05101610
LL09				
LL10		4822 157 10884	EMI FILTER, BLM11A221S	FN31000010
LM01			EMI FILTER, NFM41P11C204	FM31204010
LM02		4822 242 10582	L.C. FILTER, SBP-4930 2.88MHZ-BPF	FF30288010
LM03			CHIP INDUCTANCE, 68 μ H	LU12683010
LR01			EMI FILTER, NFM41P11C204	FM31204010
L601			EMI FILTER, NFM41P11C204	FM31204010
L603			EMI FILTER, NFM41P11C204	FM31204010
L681				
I		4822 157 70322	EMI FILTER, NFM61R10T102	FM32102010
L685				
XL01		4822 242 80349	CER. VIB., 8.0MHZ (EFO V)	FQ08004030
XM01		4822 242 10576	X'TAL, FXO-31FX 46.08MHZ- OSC	JX46001380
XM02		4822 242 10577	X'TAL, CX-5F 18.432MHZ-	JX18001380
XR01		4822 242 10578	X'TAL, CX-5F(24.5760MHZ)	JX24001380
X601		4822 242 10579	CER.VIB., EFOJ3385E5 33.868MHZ	FQ03385020
			P804-POWER CIRCUIT BOARD	
			P804-CAPACITORS	
CL91		4822 122 40617	CER., 0.1 μ F +80%-20%	DD38104010
CL92		4822 122 40617	CER., 0.1 μ F +80%-20%	DD38104010
C751				
I		4822 124 21894	ELECT., 10 μ F 16V	EJ10601610
C756				
C761		4822 122 30043	CER., 0.01 μ F +80%-20%	DK18103310
C762		4822 122 40588	CER., 0.022 μ F $\pm 20\%$	DA17223110
C781				
I	/02B	4822 126 10408	CER., 220PF $\pm 10\%$	DA16221110
C788				
▲ C801		4822 122 33276	CER., 0.01 μ F $\pm 20\%$	DK17103840
▲ C802		4822 122 33276	CER., 0.01 μ F $\pm 20\%$	DK17103840

(VERS.:VERSION, U:U.S.A., F:JAPAN, K:FAR EAST, **:EUROPE)

POS. NO	VERS. COLOR	PART NO. (FOR PCS)	DESCRIPTION	PART NO. (MJ)
C804				
I		4822 122 30043	CER., 0.01 μ F +80%-20%	DK18103310
C807				
C808		4822 124 22695	ELECT., 2200 μ F M 35VRA-2	OA22803520
C809		4822 124 22695	ELECT., 2200 μ F M 35VRA-2	OA22803520
C810		4822 124 22243	ELECT., 6800 μ F 16VRA2	OA68801620
C811		4822 124 90388	ELECT., 3300 μ F 16V RA2	OA33801620
C814		4822 122 30043	CER., 0.01 μ F +80%-20%	DK18103310
C818		4822 122 40588	CER., 0.022 μ F $\pm 20\%$	DA17223110
C819		4822 122 40588	CER., 0.022 μ F $\pm 20\%$	DA17223110
C820		4822 122 40588	CER., 0.022 μ F $\pm 20\%$	DA17223110
C823		4822 122 40588	CER., 0.022 μ F $\pm 20\%$	DA17223110
C824		4822 122 40588	CER., 0.022 μ F $\pm 20\%$	DA17223110
C831				
I		4822 122 40588	CER., 0.022 μ F $\pm 20\%$	DA17223110
C837				
C838		4822 126 10364	CER., 100PF $\pm 10\%$	DA16101110
C840		4822 122 30043	CER., 0.01 μ F +80%-20%	DK18103310
C841		4822 122 30043	CER., 0.01 μ F +80%-20%	DK18103310
C842		4822 122 30043	CER., 0.01 μ F +80%-20%	DK18103310
C844			FILM, 0.22 μ F $\pm 5\%$ 50V	
C851		4822 124 23054	ELECT., 0.47 μ F 50V	EJ47405010
C852		4822 124 23053	ELECT., 1 μ F 50V	EJ10505010
C854		4822 122 30043	CER., 0.01 μ F +80%-20%	DK18103310
C871		4822 122 40588	CER., 0.022 μ F $\pm 20\%$	DA17223110
C873		4822 122 40588	CER., 0.022 μ F $\pm 20\%$	DA17223110
C874		4822 124 21894	ELECT., 10 μ F 16V	EJ10601610
			P804-CAPACITORS(COMMON)	
			ELECTROLYTIC CAP. ONE-WAY LEAD TYPE, TOLERANCE $\pm 20\%$ C803, C812, C813, C815-C817, C821, C822, C825- C830, C839, C843, C844, C853, C872	
			P804-RESISTORS	
R761		4822 117 10158	1 Ω $\pm 5\%$ 1/4W	GG05010140
R801		4822 117 10158	1 Ω $\pm 5\%$ 1/4W	GG05010140
R805		4822 117 10158	1 Ω $\pm 5\%$ 1/4W	GG05010140
R809		4822 117 10158	1 Ω $\pm 5\%$ 1/4W	GG05010140
R810		4822 117 10158	1 Ω $\pm 5\%$ 1/4W	GG05010140
R812		4822 117 10158	1 Ω $\pm 5\%$ 1/4W	GG05010140
R871		4822 052 10109	10 Ω $\pm 5\%$ 1/6W	GG05100160
			P804-RESISTORS(COMMON)	
			CARBON FILM FIXED RES., $\pm 5\%$ 1/6W: R701-R726, R731-R736, R741- R748, R751-R756, R807, R808 R813-R815, R851-R861, R872- R877, RL91	
			P804-SEMICONDUCTORS	
D701				
I		4822 130 32362	DIODE, 1SS176, A165, 1SS254 30V 0.1A	HD20002000
D704				
▲ D801		4822 130 33057	DIODE, S2VB20	HE20011290
▲ D802		4822 130 31007	DIODE, S4VB-20	HE20015290
▲ D803		4822 130 32968	DIODE, RL203-M11 2A-200V	HD20001710
▲ D804		4822 130 32968	DIODE, RL203-M11 2A-200V	HD20001710
▲ D807				
I		4822 130 82421	DIODE, 1D31A/200V	HD20002710
▲ D810				

(VERS.:VERSION, U:U.S.A., F:JAPAN, K:FAR EAST, *:EUROPE)

POS. NO	VERS. COLOR	PART NO. (FOR PCS)	DESCRIPTION	PART NO. (MJJ)
D811		4822 130 82421	DIODE, 1D3 1A/200V	HD20002710
D815				
D816		4822 130 32968	DIODE, RL203-M11 2A-200V	HD20001710
D817		4822 130 82421	DIODE, 1D3 1A/200V	HD20002710
D818		4822 130 82421	DIODE, 1D3 1A/200V	HD20002710
D820		4822 130 82421	DIODE, 1D3 1A/200V	HD20002710
D822		4822 130 82421	DIODE, 1D3 1A/200V	HD20002710
D836		4822 130 32362	DIODE, 1SS176, MA165, 1SS254 30V 0.1A	HD20002000
D851		4822 130 82421	DIODE, 1D3 1A/200V	HD20002710
D853		4822 130 82421	DIODE, 1D3 1A/200V	HD20002710
D855		4822 130 80316	ZENER DIODE, NTJ3.6A 3.6V	HD30361000
D856		4822 130 32362	DIODE, 1SS176, MA165, 1SS254 30V 0.1A	HD20002000
D871		4822 130 80317	ZENER DIODE, 5.1V MTZJ5.1B RD5.1ES-B2 04AZ5.1Y	HD30511000
Q701		4822 130 42594	DIG.TRS., DTC144ES/UN4213 47K, 47K	BA20002000
Q705				
Q706		4822 130 61227	DIG.TRS., DTA114ES/UN4111 10K, 10K	BA10001000
Q710				
Q711		4822 130 43818	TRS., 2SC2878 A/B	HT328782A0
Q718				
Q801		4822 209 31629	IC, NJM78M15FA(0.5A 15V)	HC38515090
Q802		4822 209 61526	IC, NJM79M15FA(0.5A -15V)	HC39515090
Q803		4822 209 31631	IC, NJM7805FA +5V	HC38905090
Q804		4822 209 30063	IC, NJM79M05AF -5V 0.5A	HC39505090
Q805		4822 209 31631	IC, NJM7805FA +5V	HC38905090
Q806		4822 209 71373	IC, NJM78L05A	HC38105090
Q807		4822 209 14883	IC, S-806C V-SENSOR 4.55V	HC10075530
Q808		4822 130 62335	TRS., 2SD2033(E) 120V 1.8W	HT420331E0
Q851		4822 130 42298	TRS., (2SC) C536SP, C2458, C3311, C1740S	HT30001000
Q852		4822 130 42298	TRS., (2SC) C536SP, C2458, C3311, C1740S	HT30001000
Q853		4822 130 61227	DIG.TRS., DTA114ES/UN4111 10K, 10K	BA10001000
Q854		4822 130 62335	TRS., 2SD2033(E) 120V 1.8W	HT420331E0
Q855		4822 130 62335	TRS., 2SD2033(E) 120V 1.8W	HT420331E0
Q856		4822 130 61227	DIG.TRS., DTA114ES/UN4111 10K, 10K	BA10001000
Q857		4822 130 61227	DIG.TRS., DTA114ES/UN4111 10K, 10K	BA10001000
Q871		4822 209 30193	IC, LB1641 MOTOR DRIVER	HC10279030
			P804-MISCELLANEOUS	
▲ F801	F U		FUSE, 500MA 250V UL, CSA, MITI	FS10050350
▲ F801	/02B		FUSE, 160 MA 250V BS LISTED	FS10016850
▲ F802	F U		FUSE, T400MA 250V	FS20040210
▲ F802	K/02B		FUSE, T160MA 250V	FS20016200
J701		4822 265 31045	TERMINAL, 2P RCA W/R/GL	YT02021080
J702			TERMINAL, 6P RCA BLK-AU	YT02060550
J703			TERMINAL, 6P RCA BLK-AU	YT02060550
J704		4822 267 41009	TERMINAL, 2P RCA (RC5) OR	YT02020890
▲ J802	F	4822 267 31686	JACK, AC OUTLET 1P	YJ04001780
▲ J802	U	4822 267 31686	JACK, AC OUTLET 1P	YJ04001780

(VERS.:VERSION, U:U.S.A., F:JAPAN, K:FAR EAST, *:EUROPE)

POS. NO	VERS. COLOR	PART NO. (FOR PCS)	DESCRIPTION	PART NO. (MJJ)
L701		4822 280 20501	RELAY, MR62-24SR 24V	LY20240410
L704				
▲ L801		4822 157 70419	FILTER, LF-4D-102	FN01020020
▲ L802		4822 280 70354	RELAY, VB 24MBU-510 5A/240VAC	LY20240310
▲ L803		4822 280 70354	RELAY, VB 24MBU-510 5A/240VAC	LY20240310
L891		4822 242 73843	EMI FILTER, DSS306-91-F-1223Z	FM12223010
L897				
			P854-POWER SW CIRCUIT BOARD	
			P854-CAPACITORS	
▲ C891		4822 122 33276	CER., 0.01 μ F \pm 20%	DK17103840
▲ S891		4822 276 11654	PUSH SW., POWER SW. 1.5MM TV-5	SP01010960
			P884-VOLTAGE SELECT CIRCUIT BOARD	
			P884-MISCELLANEOUS	
▲ F881	K		FUSE, 160 MA 250V BS	FS10016850
▲ F882	K	4822 253 30394	FUSE, 315 MA 250V BS	FS10031850
▲ S881	K	4822 277 21825	SLIDE SW., SDKGA4 SEMKO	SS02021510
			PD04-DAC, CROSS-OVER CIRCUIT BOARD	
			PD04-CAPACITORS	
CD01		4822 126 10935	ELECT., 100 μ F 6.3V	EJ10700610
CD02		4822 126 11687	CER., 0.1 μ F +80%-20%	DK98104200
I				
CD05		4822 124 23056	ELECT., 47 μ F 10V	EJ47601010
CD06		4822 126 10935	ELECT., 100 μ F 6.3V	EJ10700610
CD10		4822 124 11074	ELECT., 10 μ F 16V	EY10601620
CD11		4822 124 11074	ELECT., 10 μ F 16V	EY10601620
CD12		4822 122 33752	CER., 15PF \pm 5% 50V	DD95150300
CD13		4822 122 33752	CER., 15PF \pm 5% 50V	DD95150300
CD14				
CD19		4822 126 11687	CER., 0.1 μ F +80%-20%	DK98104200
I				
CD22		4822 122 33752	CER., 15 PF \pm 5% 50V	DD95150300
CD23		4822 122 33752	CER., 15 PF \pm 5% 50V	DD95150300
CD24				
CD25		4822 124 21894	ELECT., 10 μ F 16V	EJ10601610
I				
CD28		4822 126 11687	CER., 0.1 μ F +80%-20%	DK98104200
CD29		4822 126 11687	CER., 0.1 μ F +80%-20%	DK98104200
CD30		4822 126 10935	ELECT., 100 μ F 6.3V	EJ10700610
CD31		4822 126 10935	ELECT., 100 μ F 6.3V	EJ10700610
CD32		4822 126 11687	CER., 0.1 μ F +80%-20%	DK98104200
I				
CD35		4822 124 23056	ELECT., 47 μ F 10V	EJ47601010
CD36		4822 126 10935	ELECT., 100 μ F 6.3V	EJ10700610
CD40		4822 124 11074	ELECT., 10 μ F 16V	EY10601620
CD41		4822 124 11074	ELECT., 10 μ F 16V	EY10601620
CD42		4822 122 33752	CER., 15PF \pm 5% 50V	DD95150300
CD43		4822 122 33752	CER., 15PF \pm 5% 50V	DD95150300
CD44				
CD49		4822 126 11687	CER., 0.1 μ F +80%-20%	DK98104200
I				
CD52				

(VERS.:VERSION, U:U.S.A., F:JAPAN, K:FAR EAST, **:EUROPE)

POS. NO	VERS. COLOR	PART NO. (FOR PCS)	DESCRIPTION	PART NO. (MJI)
CD53				
		4822 126 11724	CER., 560PF ±10%	DK96561300
CD56				
CD61		4822 126 10935	ELECT., 100 μF 6.3V	EJ10700610
CD62				
		4822 126 11687	CER., 0.1 μF +80%-20%	DK98104200
CD65				
CD66		4822 124 23056	ELECT., 47 μF 10V	EJ47601010
CD69		4822 126 11724	CER., 560PF ±10%	DK96561300
CD70		4822 126 10935	ELECT., 100 μF 6.3V	EJ10700610
CD71		4822 124 11074	ELECT., 10 μF 16V	EY10601620
CD72		4822 124 11074	ELECT., 10 μF 16V	EY10601620
CD73		4822 122 33752	CER., 15PF ±5% 50V	DD95150300
CD74		4822 126 11724	CER., 560PF ±10%	DK96561300
CD79				
		4822 126 11687	CER., 0.1 μF +80%-20%	DK98104200
CD82				
CD91		4822 126 11687	CER., 0.1 μF +80%-20%	DK98104200
CE01		4822 122 33752	CER., 15P ±5% 50V	DD95150300
CE03		4822 124 21894	ELECT., 10 μF 16V	EJ10601610
CE04		4822 124 21894	ELECT., 10 μF 16V	EJ10601610
CE05		4822 126 11687	CER., 0.1U +80-20%	DK98104200
CE06		4822 126 11687	CER., 0.1U +80-20%	DK98104200
CE07		4822 124 21894	ELECT., 10 μF 16V	EJ10601610
CE08		4822 124 21894	ELECT., 10 μF 16V	EJ10601610
CE13		4822 124 21894	ELECT., 10 μF 16V	EJ10601610
CE14		4822 124 21894	ELECT., 10 μF 16V	EJ10601610
CE15				
		4822 126 11687	CER., 0.1 μF +80%-20%	DK98104200
CE18				
CE19		4822 122 33752	CER., 15P ±5% 50V	DD95150300
CE20		4822 122 33752	CER., 15P ±5% 50V	DD95150300
CE21		4822 124 21894	ELECT., 10 μF 16V	EJ10601610
CE22		4822 124 21894	ELECT., 10 μF 16V	EJ10601610
CE23		4822 126 11687	CER., 0.1 μF +80%-20%	DK98104200
CE24		4822 126 11687	CER., 0.1 μF +80%-20%	DK98104200
CE25		4822 124 21894	ELECT., 10 μF 16V	EJ10601610
CE26		4822 124 21894	ELECT., 10 μF 16V	EJ10601610
CE31		4822 122 33752	CER., 15P ±5% 50V	DD95150300
CE33		4822 124 21894	ELECT., 10 μF 16V	EJ10601610
CE34		4822 124 21894	ELECT., 10 μF 16V	EJ10601610
CE35		4822 126 11687	CER., 0.1 μF +80%-20%	DK98104200
CE36		4822 126 11687	CER., 0.1 μF +80%-20%	DK98104200
CE37		4822 124 21894	ELECT., 10 μF 16V	EJ10601610
CE38		4822 124 21894	ELECT., 10 μF 16V	EJ10601610
CE43		4822 124 21894	ELECT., 10 μF 16V	EJ10601610
CE44		4822 124 21894	ELECT., 10 μF 16V	EJ10601610
CE45				
		4822 126 11687	CER., 0.1 μF +80%-20%	DK98104200
CE48				
CE49		4822 122 33752	CER., 15P ±5% 50V	DD95150300
CE50		4822 122 33752	CER., 15P ±5% 50V	DD95150300
CE51		4822 124 21894	ELECT., 10 μF 16V	EJ10601610
CE52		4822 124 21894	ELECT., 10 μF 16V	EJ10601610
CE53		4822 126 11687	CER., 0.1 μF +80%-20%	DK98104200
CE54		4822 126 11687	CER., 0.1 μF +80%-20%	DK98104200
CE55		4822 124 21894	ELECT., 10 μF 16V	EJ10601610
CE56		4822 124 21894	ELECT., 10 μF 16V	EJ10601610
CE60		4822 124 21894	ELECT., 10 μF 16V	EJ10601610
CE63		4822 124 21894	ELECT., 10 μF 16V	EJ10601610
CE64		4822 124 21894	ELECT., 10 μF 16V	EJ10601610

(VERS.:VERSION, U:U.S.A., F:JAPAN, K:FAR EAST, **:EUROPE)

POS. NO	VERS. COLOR	PART NO. (FOR PCS)	DESCRIPTION	PART NO. (MJI)
CE69		4822 124 21894	ELECT., 10 μF 16V	EJ10601610
CE70		4822 126 11687	CER., 0.1 μF +80%-20%	DK98104200
CE71		4822 126 11687	CER., 0.1 μF +80%-20%	DK98104200
CE72		4822 124 21894	ELECT., 10 μF 16V	EJ10601610
CE73		4822 122 33752	CER., 15P ±5% 50V	DD95150300
CE74		4822 122 33752	CER., 15P ±5% 50V	DD95150300
CE75		4822 126 11687	CER., 0.1 μF +80%-20%	DK98104200
CE76		4822 126 11687	CER., 0.1 μF +80%-20%	DK98104200
CE77		4822 124 21894	ELECT., 10 μF 16V	EJ10601610
CE82		4822 124 21894	ELECT., 10 μF 16V	EJ10601610
CE83		4822 126 11687	CER., 0.1 μF +80%-20%	DK98104200
CE84		4822 126 11687	CER., 0.1 μF +80%-20%	DK98104200
CE85		4822 124 21894	ELECT., 10 μF 16V	EJ10601610
CE86		4822 124 21894	ELECT., 10 μF 16V	EJ10601610
CE87		4822 126 11687	CER., 0.1 μF +80%-20%	DK98104200
CE88		4822 126 11687	CER., 0.1 μF +80%-20%	DK98104200
CE89		4822 124 21894	ELECT., 10 μF 16V	EJ10601610
CM91		4822 126 11567	CER., 0.022 μF ±10%	DK96223200
CM92		4822 126 11687	CER., 0.1 μF +80%-20%	DK98104200
CM93		4822 126 10935	ELECT., 100 μF 6.3V	EJ10700610
CM94		4822 126 11687	CER., 0.1 μF +80%-20%	DK98104200
CM95		4822 126 11687	CER., 0.1 μF +80%-20%	DK98104200
CM96		5322 126 11578	CER., 1000 PF ±10%	DK96102300
CM97		4822 126 10935	ELECT., 100 μF 6.3V	EJ10700610
CM98		4822 126 11687	CER., 0.1 μF +80%-20%	DK98104200
CR93		4822 126 11687	CER., 0.1 μF +80%-20%	DK98104200
CR94		4822 126 10935	ELECT., 100 μF 6.3V	EJ10700610
—				
C***			PD04-CAPACITORS (COMMON) PLASTIC FILM CAP., ±5% 50V: CD07-, CD08, CD15-CD18, CD37, CD38, CD45-CD48, CD67, CD68, CD75-CD78, CE09-CE12 CE39-CE42, CE67, CE68, CE78-CE81, CE95, CE96	
RD03				
		4822 051 30472	CHIP, 4.7K Ω ±5% 1/16W	NN05472610
RD06				
RD09				
		4822 051 30472	CHIP, 4.7K Ω ±5% 1/16W	NN05472610
RD14				
RD15		4822 051 30472	CHIP, 4.7K Ω ±5% 1/16W	NN05472610
RD16		4822 051 30472	CHIP, 4.7K Ω ±5% 1/16W	NN05472610
RD19		4822 051 30473	CHIP, 47K Ω ±5% 1/16W	NN05473610
RD20		4822 051 30473	CHIP, 47K Ω ±5% 1/16W	NN05473610
RD21				
		4822 051 30153	CHIP, 15K Ω ±5% 1/16W	NN05153610
RD24				
RD25		4822 051 30103	CHIP, 10K Ω ±5% 1/16W	NN05103610
RD26		4822 051 30103	CHIP, 10K Ω ±5% 1/16W	NN05103610
RD27		4822 051 30104	CHIP, 100K Ω ±5% 1/16W	NN05104610
RD28		4822 051 30104	CHIP, 100K Ω ±5% 1/16W	NN05104610
RD29		4822 051 30101	CHIP, 100 Ω ±5% 1/16W	NN05101610
RD33				
		4822 051 30472	CHIP, 4.7K Ω ±5% 1/16W	NN05472610
RD36				

(VERS. :VERSION, U:U.S.A., F:JAPAN, K:FAR EAST, **:EUROPE)

POS. NO	VERS. COLOR	PART NO. (FOR PCS)	DESCRIPTION	PART NO. (MJI)
RD39		4822 051 30472	CHIP, 4.7K Ω $\pm 5\%$ 1/16W	NN05472610
RD40		4822 051 30472	CHIP, 4.7K Ω $\pm 5\%$ 1/16W	NN05472610
RD41				
I		4822 051 30222	CHIP, 2.2K Ω $\pm 5\%$ 1/16W	NN05222610
RD44				
RD45		4822 051 30472	CHIP, 4.7K Ω $\pm 5\%$ 1/16W	NN05472610
RD46		4822 051 30472	CHIP, 4.7K Ω $\pm 5\%$ 1/16W	NN05472610
RD63		4822 051 30472	CHIP, 4.7K Ω $\pm 5\%$ 1/16W	NN05472610
RD64		4822 051 30472	CHIP, 4.7K Ω $\pm 5\%$ 1/16W	NN05472610
RD65		4822 051 30473	CHIP, 47K Ω $\pm 5\%$ 1/16W	NN05473610
RD66		4822 051 30473	CHIP, 47K Ω $\pm 5\%$ 1/16W	NN05473610
RD69		4822 051 30472	CHIP, 4.7K Ω $\pm 5\%$ 1/16W	NN05472610
RD70		4822 051 30472	CHIP, 8.2K Ω $\pm 5\%$ 1/16W	NN05472610
RD71				
I		4822 051 30222	CHIP, 2.2K Ω $\pm 5\%$ 1/16W	NN05222610
RD74				
RD75		4822 051 30472	CHIP, 4.7K Ω $\pm 5\%$ 1/16W	NN05472610
RD76		4822 051 30472	CHIP, 4.7K Ω $\pm 5\%$ 1/16W	NN05472610
RD78		4822 116 83221	CHIP, 8.2K Ω $\pm 5\%$ 1/16W	NN05822610
RD80		4822 117 10158	1 Ω $\pm 5\%$ 1/4W	GG05010140
RD81		4822 051 30472	CHIP, 4.7K Ω $\pm 5\%$ 1/16W	NN05472610
RE01		4822 051 30103	CHIP, 10K Ω $\pm 5\%$ 1/16W	NN05103610
RE02		4822 051 30101	CHIP, 100 Ω $\pm 5\%$ 1/16W	NN05101610
RE03		4822 051 30101	CHIP, 100 Ω $\pm 5\%$ 1/16W	NN05101610
RE04		4822 051 30101	CHIP, 100 Ω $\pm 5\%$ 1/16W	NN05101610
RE07				
I		4822 051 30473	CHIP, 47K Ω $\pm 5\%$ 1/16W	NN05473610
RE10				
RE11		4822 051 30103	CHIP, 10K Ω $\pm 5\%$ 1/16W	NN05103610
RE12		4822 051 30103	CHIP, 10K Ω $\pm 5\%$ 1/16W	NN05103610
RE13		4822 051 30102	CHIP, 1K Ω $\pm 5\%$ 1/16W	NN05102610
RE14		4822 051 30102	CHIP, 1K Ω $\pm 5\%$ 1/16W	NN05102610
RE15		4822 051 30223	CHIP, 22K Ω $\pm 5\%$ 1/16W	NN05223610
RE16		4822 051 30223	CHIP, 22K Ω $\pm 5\%$ 1/16W	NN05223610
RE17				
I		4822 051 30103	CHIP, 10K Ω $\pm 5\%$ 1/16W	NN05103610
RE20				
RE21		4822 051 30153	CHIP, 15K Ω $\pm 5\%$ 1/16W	NN05153610
RE22		4822 051 30153	CHIP, 15K Ω $\pm 5\%$ 1/16W	NN05153610
RE23		4822 051 30103	CHIP, 10K Ω $\pm 5\%$ 1/16W	NN05103610
RE24		4822 051 30103	CHIP, 10K Ω $\pm 5\%$ 1/16W	NN05103610
RE25				
RE26		4822 051 30104	CHIP, 100K Ω $\pm 5\%$ 1/16W	NN05104610
I				
RE35				
I		4822 051 30473	CHIP, 47K Ω $\pm 5\%$ 1/16W	NN05473610
RE38				
RE39		4822 051 30103	CHIP, 10K Ω $\pm 5\%$ 1/16W	NN05103610
RE40		4822 051 30103	CHIP, 10K Ω $\pm 5\%$ 1/16W	NN05103610
RE41		4822 051 30102	CHIP, 1K Ω $\pm 5\%$ 1/16W	NN05102610
RE42		4822 051 30102	CHIP, 1K Ω $\pm 5\%$ 1/16W	NN05102610
RE43		4822 051 30223	CHIP, 22K Ω $\pm 5\%$ 1/16W	NN05223610
RE44		4822 051 30223	CHIP, 22K Ω $\pm 5\%$ 1/16W	NN05223610
RE45				
I		4822 051 30103	CHIP, 10K Ω $\pm 5\%$ 1/16W	NN05103610
RE50				
RE51				
I		4822 051 30104	CHIP, 100K Ω $\pm 5\%$ 1/16W	NN05104610
RE56				
RE61		4822 051 30104	CHIP, 100K Ω $\pm 5\%$ 1/16W	NN05104610
RE62		4822 051 30104	CHIP, 100K Ω $\pm 5\%$ 1/16W	NN05104610
RE65		4822 051 30473	CHIP, 47K Ω $\pm 5\%$ 1/16W	NN05473610

(VERS. :VERSION, U:U.S.A., F:JAPAN, K:FAR EAST, **:EUROPE)

POS. NO	VERS. COLOR	PART NO. (FOR PCS)	DESCRIPTION	PART NO. (MJI)
RE66		4822 051 30473	CHIP, 47K Ω $\pm 5\%$ 1/16W	NN05473610
RE67		4822 051 30103	CHIP, 10K Ω $\pm 5\%$ 1/16W	NN05103610
RE68		4822 051 30102	CHIP, 1K Ω $\pm 5\%$ 1/16W	NN05102610
RE69		4822 051 30104	CHIP, 100K Ω $\pm 5\%$ 1/16W	NN05104610
RE70		4822 051 30223	CHIP, 22K Ω $\pm 5\%$ 1/16W	NN05223610
RE71				
I		4822 051 30103	CHIP, 10K Ω $\pm 5\%$ 1/16W	NN05103610
RE80				
RE81		4822 051 30392	CHIP, 3.9K Ω $\pm 5\%$ 1/16W	NN05392610
RE82		4822 051 30104	CHIP, 100K Ω $\pm 5\%$ 1/16W	NN05104610
RE83				
I		4822 051 30153	CHIP, 15K Ω $\pm 5\%$ 1/16W	NN05153610
RE86				
RE87		4822 051 30104	CHIP, 100K Ω $\pm 5\%$ 1/16W	NN05104610
RE90		4822 051 30103	CHIP, 10K Ω $\pm 5\%$ 1/16W	NN05103610
RE91		4822 116 83212	CHIP, 18K Ω $\pm 5\%$ 1/16W	NN05183610
RE92		4822 116 83212	CHIP, 18K Ω $\pm 5\%$ 1/16W	NN05183610
RE93		4822 051 30104	CHIP, 100K Ω $\pm 5\%$ 1/16W	NN05104610
RE94		4822 051 30333	CHIP, 33K Ω $\pm 5\%$ 1/16W	NN05333610
RE95		4822 051 30224	CHIP, 220K Ω $\pm 5\%$ 1/16W	NN05224610
RE96		4822 051 30333	CHIP, 33K Ω $\pm 5\%$ 1/16W	NN05333610
RE97		4822 051 30273	CHIP, 27K Ω $\pm 5\%$ 1/16W	NN05273610
RM91		4822 051 30154	CHIP, 150K Ω $\pm 5\%$ 1/16W	NN05154610
RM92		4822 051 30561	CHIP, 560 Ω $\pm 5\%$ 1/16W	NN05561610
RM93		4822 051 30829	CHIP, 82 Ω $\pm 5\%$ 1/16W	NN05820610
RM94		4822 051 30102	CHIP, 1K Ω $\pm 5\%$ 1/16W	NN05102610
RM96		4822 051 30103	CHIP, 10K Ω $\pm 5\%$ 1/16W	NN05103610
RM97		4822 051 30103	CHIP, 10K Ω $\pm 5\%$ 1/16W	NN05103610
RM98		4822 051 30103	CHIP, 10K Ω $\pm 5\%$ 1/16W	NN05103610
RR91		4822 051 30759	CHIP, 75 Ω $\pm 5\%$ 1/16W	NN05750610
RR99		4822 116 82487	CHIP, 0 Ω 1/16W	NN05000610
LM91		4822 116 82487	CHIP, 0 Ω 1/16W	NN05000610
LR91		4822 116 82487	CHIP, 0 Ω 1/16W	NN05000610
			PD04-SEMICONDUCTORS	
QD01		4822 209 33812	IC, TDA1305T DAC	HC10122490
QD02		4822 209 33812	IC, TDA1305T DAC	HC10122490
QD03		4822 209 33812	IC, TDA1305T DAC	HC10122490
QD05		4822 209 83357	IC, NJM4560M	HC10029090
QD06		4822 209 83357	IC, NJM4560M	HC10029090
QD07		4822 209 83357	IC, NJM4560M	HC10029090
QD09		4822 209 83357	IC, NJM4560M	HC10029090
QD10		4822 209 83357	IC, NJM4560M	HC10029090
QD11		4822 209 83357	IC, NJM4560M	HC10029090
QD13		4822 209 71451	IC, NJM4558M FLAT	HC10011090
QD14		4822 209 32442	IC, TC7WU04F	HC000305K0
QE04		4822 209 14869	IC, NJU7311AM ANA. SW	HC10151090
QE05				
I		4822 209 71451	IC, NJM4558M FLAT	HC10011090
QE14				
QM91			CHIP TR., 2SC4081 (Q, R) 2SC4116 (Y, GR)	HX300012A0
QM92		4822 209 71451	IC, NJM4558M FLAT	HC10011090
			PD04-MISCELLANEOUS	
JD01			PLUG, TKC-G12P-B1	YP06020940
JD02			PLUG, TKC-G12P-B1	YP06020940
JD03			PLUG, TKC-G12P-B1	YP06020940
JR01			TERMINAL, 1P YKC21-3707	YT02011030
JR02			TERMINAL, 1P YKC21-3707	YT02011030
JR03		4822 218 11487	OPT. CONNECTOR, GP1F32R	YJ15000150

(VERS.:VERSION, U:U.S.A., F:JAPAN, K:FAR EAST, **:EUROPE)

POS. NO	VERS. COLOR	PART NO. (FOR PCS)	DESCRIPTION	PART NO. (MJI)
LD01 LD04		4822 242 73843	EMI FILTER, DSS306-91-F-223Z	FM12223010 FM12223010
LM91 LR91		4822 116 82487 4822 116 82487	CHIP, 0Ω 1/16W CHIP, 0Ω 1/16W	NN05000610 NN05000610
			PU04-FRONT CIRCUIT BOARD	
			PU04-CAPACITORS	
CU01		4822 126 11558	CER., 0.1 μF ±20% 50V	DA17104110
CU02		4822 126 10513	CER., 47PF ±5%	DA15470110
CU03		4822 126 11558	CER., 0.1 μF ±20% 50V	DA17104110
CU04		4822 124 80651	ELECT., 100 μF 6.3V	EG10700650
CU05		4822 126 11558	CER., 0.1 μF ±20% 50V	DA17104110
			PU04-RESISTORS	
RU13		4822 052 10101	100Ω ±5% 1/6W	GG05101160
RU17		4822 052 10101	100Ω ±5% 1/6W	GG05101160
			PU04-RESISTOR(COMMON)	
R***			CARBON FILM FIXED RES., ±5% 1/6W:RU01-RU12, RU14- RU16, RU21-RU26	
			PU04-SEMICONDUCTORS	
DU03 DU07		4822 130 81715	L.E.D., LT3K44B GREEN	HI10095320
DU08		4822 130 80326	L.E.D., LT3D8B RED	HI10062320
DU09		4822 130 80325	L.E.D., LT3H8B AMBR	HI10064320
DU10		4822 130 80326	L.E.D., LT3D8B RED	HI10062320
DU11		4822 130 80326	L.E.D., LT3D8B RED	HI10062320
DU12		4822 130 81715	L.E.D., LT3K44B GREEN	HI10095320
DU13		4822 130 32362	DIODE, 1SS176, MA165, 1SS25430V 0.1A	HD20002000
QU01		4822 130 10684	PHOTO UNIT, RPM-674CBR-L	HW10003210
QU02		4822 130 42298	TRS., (2SC) C536SP, C2458, C3311, C1740S	HT30001000
QU03		4822 130 42715	TRS., (2SA) A608SP, A1048, A1309, A933S	HT10001000
			PU04-MISCELLANEOUS	
JU01			JACK, FFC CONNECTOR	YJ07011990
SU01 SU07		4822 276 20508	PUSH SW., ALPS-SKHVAE	SP01011280
			PU54-SPK SW CIRCUIT BOARD	
			PU54-CAPACITORS	
CP01		4822 126 10513	CER., 47PF ±5%	DA15470110
CP02		4822 126 10513	CER., 47PF ±5%	DA15470110
CP03		4822 126 10513	CER., 47PF ±5%	DA15470110
CP04		4822 126 11558	CER., 0.1 μF ±20% 50V	DA17104110
			PU54-RESISTOR(COMMON)	
R***			CARBON FILM FIXED RES., ±5% 1/16W:RP01, RP03-RP09	
			PU54-MISCELLANEOUS	
SP01		4822 277 21712	SLIDE SW., SSSS92	SS02021470
SP02		4822 277 21718	SLIDE SW., SSSS9-23Z	SS02030560

(VERS.:VERSION, U:U.S.A., F:JAPAN, K:FAR EAST, **:EUROPE)

POS. NO	VERS. COLOR	PART NO. (FOR PCS)	DESCRIPTION	PART NO. (MJI)
SP03		4822 277 21718	SLIDE SW., SSSS9-23Z	SS02030560
SP04		4822 277 21712	SLIDE SW., SSSS92	SS02021470
SP05		4822 277 21712	SLIDE SW., SSSS92	SS02021470
			PV04-TRIM VOLUME CIRCUIT BOARD	
			PV04-CAPACITORS	
CV01 CV06		4822 124 21894	ELECT., 10 μF 16V	EJ10601610
CV13 CV18		4822 124 21894	ELECT., 10 μF 16V	EJ10601610
CV53 CV64		4822 122 40588	CER., 22000PF ±20% 25V	DA17223110
			PV04-CAPACITORS (COMMON)	
C***			ELECTROLYTIC CAP. TOLERANCE ±20% CV51, CV52	
			PV04-RESISTORS	
RV01 RV06		4822 101 11662	VARIABLE, 50K(K) L=22.5MM	RK05030850
			PV04-RESISTOR(COMMON)	
R***			CARBON FILM FIXED RES., ±5% 1/16W: RV11-RV22, RV29-RV46	
			PV04-SEMICONDUCTORS	
QV01 QV06		4822 209 83274	IC, NJM4560D	HC10007090
			PV54-MASTER VOLUME CIRCUIT BOARD	
			PV54-CAPACITOR	
▲ CV90		4822 122 40588	CER., 22000PF ±20% 25V	DA17223110
			PV54-CAPACITORS (COMMON)	
C***			ELECTROLYTIC CAP. TOLERANCE ±20% CV91, CV92	
			PV54-RESISTOR	
RV99		4822 101 11663	VARIABLE, 50K(VB)X6 MOTOR	RG05030230
			PV54-RESISTOR(COMMON)	
R***			CARBON FILM FIXED RES., ±5% 1/16W:RV91-RV96	