

Service Manual

DR17/N1B,/N1G,/U1B,/U1G,/F1N

Compact Disc Recorder

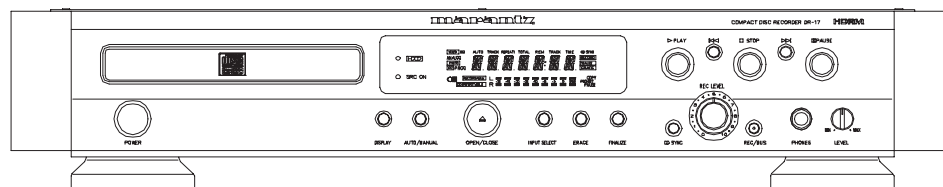

DR-17

TABLE OF CONTENTS

1. MAIN UNIT	
- Servicing the DR-17	1-1
1.1 TECHNICAL SPECIFICATIONS	1-4
1.2 WARNINGS	1-5
1.3 SERVICE HINTS	1-6
1.4 DISMOUNTING INSTRUCTIONS	1-7
1.5 BLOCK DIAGRAM	1-10
1.6 SERVICE TEST PROGRAM	1-12
1.7 FAULTFINDING GUIDE	1-13
1.8 COMPONENT DESCRIPTIONS	1-18
1.9 WIRING DIAGRAM	1-22
1.10 SCHEMATIC DIAGRAM AND PARTS LOCATION	1-23
1.11 EXPLODED VIEW AND PARTS LIST	1-32
1.12 ELECTRICAL PARTS LIST	1-35
2. CDRL3610/10 (CDR MODULE for MARANTZ)	
2.1 BLOCK DIAGRAM MAIN BOARD	2-1
2.2 PARTS LOCATION	2-3
2.3 EXPLODED VIEW AND PARTS LIST	2-7

Please use this service manual with referring to the user guide (D.F.U) without fail.

修理の際は、必ず取扱説明書を準備し操作方法を確認の上作業を行って下さい。

marantz®

- DR-17 -

MARANTZ DESIGN AND SERVICE

Using superior design and selected high grade components, **MARANTZ** company has created the ultimate in stereo sound. Only original **MARANTZ** parts can insure that your **MARANTZ** product will continue to perform to the specifications for which it is famous.

Parts for your **MARANTZ** equipment are generally available to our National Marantz Subsidiary or Agent.

ORDERING PARTS :

Parts can be ordered either by mail or by Fax.. In both cases, the correct part number has to be specified.

The following information must be supplied to eliminate delays in processing your order :

1. Complete address
2. Complete part numbers and quantities required
3. Description of parts
4. Model number for which part is required
5. Way of shipment
6. Signature : any order form or Fax. must be signed, otherwise such part order will be considered as null and void.

<p>USA MARANTZ AMERICA, INC. 440 MEDINAH ROAD ROSELLE, ILLINOIS 60172 USA PHONE : 630 - 307 - 3100 FAX : 630 - 307 - 2687</p>	<p>EUROPE / TRADING MARANTZ EUROPE B.V. P.O.BOX 80002, BUILDING SFF2 5600 JB EINDHOVEN THE NETHERLANDS PHONE : +31 - 40 - 2732241 FAX : +31 - 40 - 2735578</p>	<p>BRAZIL MARANTZ BRAZIL CAIXA POSTAL 21462 CEP 04698-970 SAO PAULO, SP, BRAZIL PHONE : 0800 - 123123(Discagem Direta Gratuita) FAX : +55 11 534. 8988</p>
<p>PROFESSIONAL AMERICAS SUPERSCOPE TECHNOLOGIES, INC. MARANTZ PROFESSIONAL PRODUCTS 2640 WHITE OAK CIRCLE, SUITE A AURORA, ILLINOIS 60504 USA PHONE : 630 - 820 - 4800 FAX : 630 - 820 - 8103</p>	<p>CANADA LENBROOK INDUSTRIES LIMITED 633 GRANITE COURT, PICKERING, ONTARIO L1W 3K1 CANADA PHONE : 905 - 831 - 6333 FAX : 905 - 831 - 6936</p>	
<p>AUSTRALIA SCAN AUDIO PTY. LTD. 52 CROWN STREET, RICHMOND 3121 VICTORIA AUSTRALIA PHONE : +61 - 3 - 9429 - 2199 FAX : +61 - 3 - 9429 - 9309</p>	<p>THAILAND MRZ STANDARD CO.,LTD 746 - 754 MAHACHAI ROAD., WANGBURAPAPIROM, PHRANAKORN, BANGKOK, 10200 THAILAND PHONE : +66 - 2 - 222 9181 FAX : +66 - 2 - 224 6795</p>	<p>SINGAPORE WO KEE HONG (S) PTE LTD WO KEE HONG CENTRE NO.23, LORONG 8, TOA PAYOH SINGAPORE 319257 PHONE : +65 2544555 FAX : +65 2502213</p>
<p>NEW ZEALAND SCAN AUDIO PTY. LTD. 8C PIERMARK DRIVE, ALBANY. NORTH SHORE, AUCKLAND. NEW ZEALAND PHONE : +64 - 9444 - 4710 FAX : +64 - 9444 - 1346</p>	<p>TAIWAN PAI- YUING CO., LTD. 6 TH FL NO, 148 SUNG KIANG ROAD, TAIPEI, 10429, TAIWAN R.O.C. PHONE : +886 - 2 - 25221304 FAX : +886 - 2 - 25630415</p>	<p>MALAYSIA WO KEE HONG ELECTRONICS SDN. BHD. NO. 102 JALAN SS 21/35, DAMANSARA UTAMA, 47400 PETALING JAYA SELANGOR DARUL EHSAN, MALAYSIA PHONE : +60 3 - 7184666 FAX : +60 3 - 7173828</p>
<p>JAPAN Technical MARANTZ JAPAN, INC. 35- 1, 7- CHOME, SAGAMIONO SAGAMIHARA - SHI, KANAGAWA JAPAN 228-8505 PHONE : +81 42 748 1013 FAX : +81 42 748 9190</p>	<p style="text-align: center;">日本マランツ株式会社</p> <p>本社 〒228-8505 神奈川県相模原市相模大野7-35-1 営業本部 〒150-0022 東京都渋谷区恵比寿南1-11-9</p>	<p>KOREA MK ENTERPRISES LTD. ROOM 604/605, ELECTRO-OFFICETEL, 16-58, 3GA, HANGANG-RO, YONGSAN-KU, SEOUL KOREA PHONE : +822 - 3232 - 155 FAX : +822 - 3232 - 154</p>

SHOCK, FIRE HAZARD SERVICE TEST :

CAUTION : After servicing this appliance and prior to returning to customer, measure the resistance between either primary AC cord connector pins (with unit NOT connected to AC mains and its Power switch ON), and the face or Front Panel of product and controls and chassis bottom.

Any resistance measurement less than 1 Megohms should cause unit to be repaired or corrected before AC power is applied, and verified before it is return to the user/customer.

Ref. UL Standard No. 1492.

In case of difficulties, do not hesitate to contact the Technical Department at above mentioned address.

Servicing the DR-17

1. INTRODUCTION:

The DR-17 is the consumer version of a CD recorder, this means that the SCMS (Serial Copy Management System) is included. The DR-17 can only record on the Audio CDRs (Consumer Use).

The DR-17 is suitable for recording and playback of CD-RW discs (CD-Re Writable disc).

Playback & Recording and Disc

Disc Player/Recorder	CD	CDR				CD-RW				SCMS
		Consumer Disc		Professional Disc		Consumer Disc		Professional Disc		
		Finalized	non Finalized	Finalized	non Finalized	Finalized	non Finalized	Finalized	non Finalized	
Audio CD Player Current products Ex:CD-17	P	P	no	P	no	no	no	no	no	-
Audio CD Player CD-RW playback Ex:CD-17MK II	P	P	no	P	no	P	no	P	no	-
CD-RW Recorder For Professional Ex:CDR630/640	P	P	P/R	P	P/R	P/R	P/R	P/R	P/R	no
CD-RW Recorder For Consumer Ex:DR-17	P	P	P/R	P	no	P/R	P/R	no	no	YES

Consumer : For Digital Audio

Professional : For General use (Including PC)

P : Playback

R : Recording

2. OPENING THE PRODUCT:

The product can be opened by removing the top cover (8 screws). Once the product is opened one can have access to the several PCB's and the main module. To have access to the Display PCB, the Headphone PCB and the lever PCB first the front cover has to be removed (See dismantling instructions on page1-7).

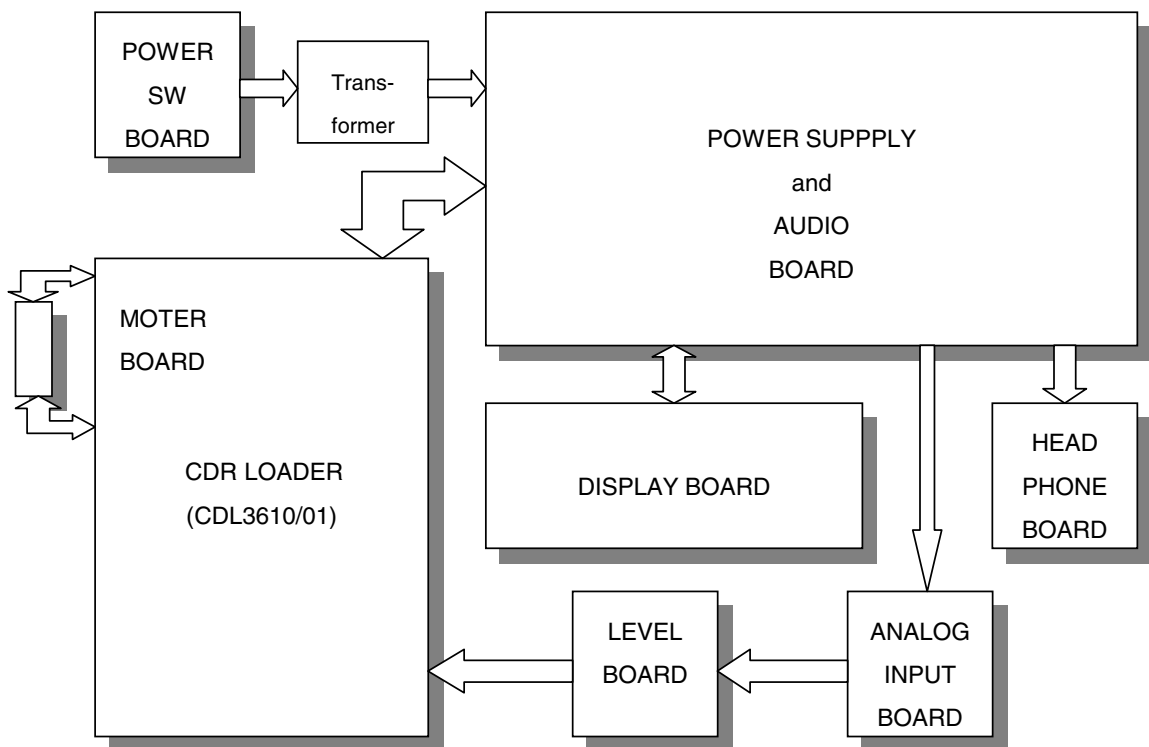

Below the several PCB's and it function and service policy will be discussed:

2.1 CDR loader (CDR main module CDL3610/01):

This complete CDR loader is considered as not repairable in the field. therefore this module will be repaired centrally. A module exchange procedure will be set up for this purpose. The module can be removed from the product by removing 10 screws and the transformer (see demounting the CDR module on page 1-7), and loosening the connectors.

This module is the complete CD recorder, it contains the following parts:

- `` CD Mechanism (CDM3610'). Underneath this mechanism a PCB is mounted which is adjusted to the mechanism (laser current settings are stored in EEPROM).
- `` Loader Assy. This mechanical assy takes care for the tray control.
- `` Main PCB. This PCB takes care that the (analog or digital) signal to be recorded is converted into a suitable signal which can be recorded on the disc.
Digital signals with an other sampling frequency then 44.1kHz will be converted in the sample rate converter (GDIN) to 44.1kHz.
Analog signals will be first converted into a digital converter by the AD converter.
This PCB also takes care that the signal from the CD (playback) is converted into a suitable digital signal (or analog via the DA converter).
The main microprocessor controls the several functions of this PCB. The system software stored in a normal DIL EPROM(7322). This EPROM(7322) is mounted on a socket, so software updates can be easily done at the dealer or service agent.

2.2 Power SW Board.

This PCB contains the Power SW, which is jointed the Power bottom on the front panel. All parts are available as spare parts.

2.3 Power Supply and Audio Board.

This PCB consists of power supply part and audio part. The power supply part delivers the several voltages for the different PCB in the DR-17. On this power supply several fuses (secondary side) are mounted on this PCB. The audio part takes care that the signal from CDR main module is converted into an analog signal via DA converter and outputs the analog signal. This PCB contains the output and input connectors also. All parts are available as spare parts.

2.4 Display Board.

This PCB contains the Display, which informs the user about the status of the recording/playback process and it also takes care for scanning the keys on the front panel. The information from the keys is fed via a I²C connection to the main microprocessor on the CDR loader module. Information which needs to be displayed is also fed via this I²C line from the main microprocessor on the CDR loader module to the display controller.
The parts for this PCB are available as service parts so this PCB can be repairable up to component level.

2.5 Headphone Board.

This PCB contains the headphone socket and potentiometer which controls the headphone volume. All parts are available as spare parts.

2.6 Analog Input Board

This PCB contains the analog input (RCA) connector. All parts are available as spare parts.

2.7 Level Board.

This PCB contains the potentiometer to adjust the level of the analogue input signal. All parts are available as spare parts.

2.8 Moter Board.

This PCB takes care for the tray speed control. All parts are available as spare parts.

3. TEST PROGRAMS.

The DR-17 has two built in test programs. These are the “**Dealer Diagnostics**” and the “**Service Diagnostics**”. Both diagnostics can be used to determine which board or module is defect.

3.1 Dealer Diagnostics.

This test diagnostics the communication between the several ICs in the CDR module. To start the test press the buttons **<PLAY>+<STOP>** simultaneously and switch on the power.

During this diagnostics the message “BUSY” is blinking on the display (this can last for a couple of minutes). When an error is detected the message “ERROR” is displayed. For the meaning of this error the service diagnostics has to be ran. Since no CD is used for this test, the playback and record parts of the module are not tested thoroughly.

3.2 Service Diagnostics.

This Diagnostics tests the main board and CDM assembly (also known as Basic Engine) of the CDR module and the keyboard and display board.

If an error is detected, an error number is displayed which refers to the error.

The test is executed with a normal CD loaded, so the recording part of the CDM is not tested thoroughly.

To start the test press the keys **<PLAY>+<NEXT>** simultaneously and switch the power on.

See the attached sheet for a flowchart of the “**SERVICE TEST PROGRAM**”.

1.1 TECHNICAL SPECIFICATIONS

General

System	compact disc digital audio
Number of channels	2 (stereo)
Applicable discs	CD, CD-R (digital audio), CD-RW (digital audio)
Power supply	AC 230 V (DR-17/N1G,B) AC 120 V (DR-17/U1G,B) AC 100 V (DR-17/FIN)
Power consumption	25 W
Operating temperature	5 - 35°C
Weight	8.0 kg
Dimensions	458 (W) x 324 (D) x 83 (H) x mm

Audio

Frequency response	20 Hz - 20 kHz
Playback S/N	105 dB
Playback dynamic range	98 dB
Playback total harmonic distortion	90 dB
Recording S/N	90 dB
Recording dynamic range	95 dB
Recording total harmonic distortion	85 dB
Line output voltage	
General CD	2 Vrms
CD with HDCD	4 Vrms
Digital coaxial output	0.5 V(pp)/75 Ω
Digital optical output	-20 dBm
Headphones	0 - 5 Vrms/8 - 2000 Ω

Recording values for line input/output

Digital coaxial input	32 - 48 kHz
(automatic sample rate conversion)	
Digital optical input	32 - 48 kHz
(automatic sample rate conversion)	
Analogue input Cinch	500 mVrms/50 k Ω

Accessories

Remote control (+ batteries)	
Audio cable (x 2)	
Digital cable	
coaxial cable (x 1) (DR-17/N1G,B • DR-17/U1G,B)	
Fiber-optic cable (x 1) (DR-17/FIN)	
Remote control cable (x 1)	
AC power cord	

1.2 WARNINGS

(GB) WARNING

All ICs and many other semiconductors are susceptible to electrostatic discharges (ESD). Careless handling during repair can reduce life drastically.
When repairing, make sure that you are connected with the same potential as the mass of the set via a wristband with resistance. Keep components and tools at this potential.

(F) ATTENTION

Tous les IC et beaucoup d'autres semi-conducteurs sont sensibles aux décharges statiques (ESD). Leur longévité pourrait être considérablement écourtée par le fait qu'aucune précaution n'est prise à leur manipulation.
Lors de réparations, s'assurer de bien être relié au même potentiel que la masse de l'appareil et enfilez le braceleterti d'une résistance de sécurité.
Veiller à ce que les composants ainsi que les outils que l'on utilise soient également à ce potentiel.

ESD

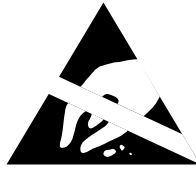

(D) WARNUNG

Alle ICs und viele andere Halbleiter sind empfindlich gegenüber elektrostatischen Entladungen (ESD). Unsorgfältige Behandlung im Reparaturfall kann die Lebensdauer drastisch reduzieren.
Sorgen Sie dafür, daß sie im Reparaturfall über ein Pulsarmband mit Widerstand mit dem Massepotential des Gerätes verbunden sind.
Halten Sie Bauteile und Hilfsmittel ebenfalls auf diesem Potential.

(NL) WAARSCHUWING

Alle IC's en vele andere halfgeleiders zijn gevoelig voor electrostatische ontladingen (ESD).
Onzorgvuldig behandelen tijdens reparatie kan de levensduur drastisch doen verminderen. Zorg ervoor dat u tijdens reparatie via een polsband met weerstand verbonden bent met hetzelfde potentiaal als de massa van het apparaat.
Houd componenten en hulpmiddelen ook op ditzelfde potentiaal.

(I) AVVERTIMENTO

Tutti IC e parecchi semi-conduttori sono sensibili alle scariche statiche (ESD).
La loro longevità potrebbe essere fortemente ridatta in caso di non osservazione della più grande cauzione alla loro manipolazione. Durante le riparazioni occorre quindi essere collegato allo stesso potenziale che quello della massa dell'apparecchio tramite un braccialetto a resistenza.
Assicurarsi che i componenti e anche gli utensili con quali si lavora siano anche a questo potenziale.

(GB) AVAILABLE ESD PROTECTION EQUIPMENT :

anti-static table mat large 1200x650x1.25mm
small 600x650x1.25mm

anti-static wristband

connection box (3 press stud connections, 1M)

extendible cable (2m, 2M , to connect wristband to connection box)

connecting cable (3m, 2M , to connect table mat to connection box)

earth cable (1M , to connect any product to mat or to connection box)

KIT ESD3 (combining all 6 prior products - small table mat)

wristband tester

4822 466 10953
4822 466 10958
4822 395 10223
4822 320 11307
4822 320 11305
4822 320 11306
4822 320 11308
4822 310 10671
4822 344 13999

(GB)

Safety regulations require that the set be restored to its original condition and that parts which are identical with those specified be used.
Safety components are marked by the symbol ▲

(F)

Les normes de sécurité exigent que l'appareil soit remis à l'état d'origine et que soient utilisées les pièces de rechange identiques à celles spécifiées.
Les composants de sécurité sont marqués ▲

SAFETY



(D)

Bei jeder Reparatur sind die geltenden Sicherheitsvorschriften zu beachten. Der Originalzustand des Gerätes darf nicht verändert werden. Für Reparaturen sind Originalersatzteile zu verwenden.
Sicherheitsbauteile sind durch das Symbol ▲ markiert.

(NL)

Veiligheidsbepalingen vereisen, dat het apparaat in zijn oorspronkelijke toestand wordt teruggebracht en dat onderdelen, identiek aan de gespecificeerde, worden toegepast.
De Veiligheidsonderdelen zijn aangeduid met het symbool ▲

(I)

Le norme di sicurezza estigono che l'apparecchio venga rimesso nelle condizioni originali e che siano utilizzati i pezzi di ricambio identici a quelli specificati.
Componenti di sicurezza sono marcati con ▲

(GB)

DANGER: Invisible laser radiation when open.
AVOID DIRECT EXPOSURE TO BEAM.

U : VERSION



N : VERSION



(S) Varning !

Osynlig laserstrålning när apparaten är öppnad och spärren är urkopplad. Betrakta ej strålen.

(DK) Advarsel !

Usynlig laserstråling ved åbning når sikkerhedsafbrydere er ude af funktion. Undgå udsættelse for stråling.

(SF) Varoitus !

Avatussa laitteessa ja suojalukituksen ohitettaessa olet alltiina näkymättömälle laserisäteilylle. Älä katso säteeseen !

(GB)

After servicing and before returning the set to customer perform a leakage current measurement test from all exposed metal parts to earth ground, to assure no shock hazard exists.
The leakage current must not exceed 0.5mA.

(F)

"Pour votre sécurité, ces documents doivent être utilisés par des spécialistes agréés, seuls habilités à réparer votre appareil en panne".

1.3 SERVICE HINTS

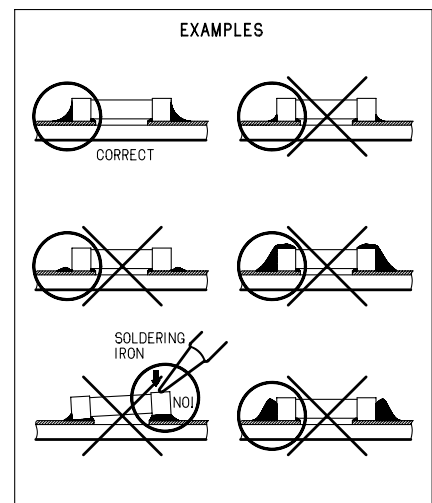
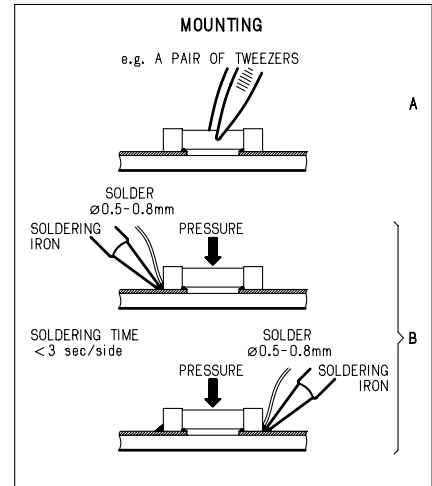
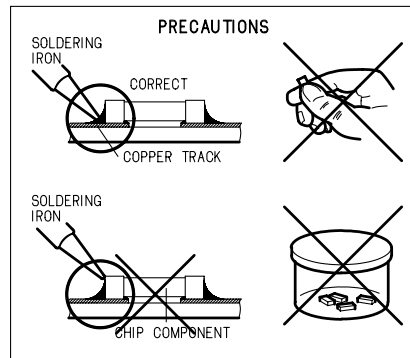
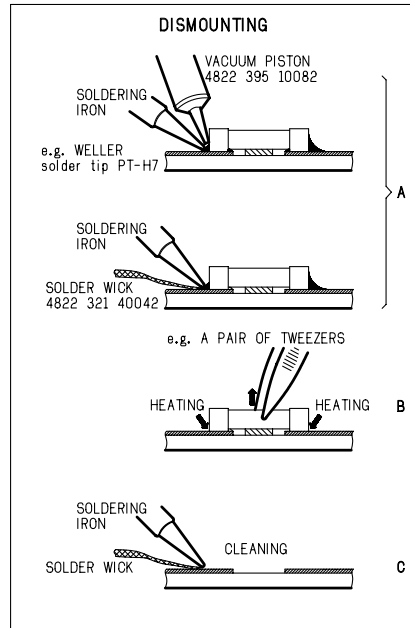
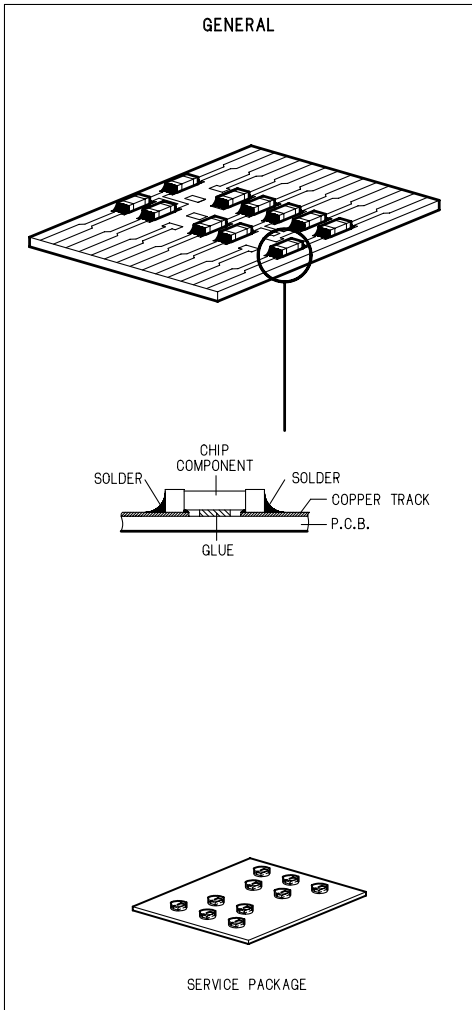

SERVICE TOOLS

Audio signals disc	4822 397 30184
Disc without errors (SBC444)+	
Disc with DO errors, black spots and fingerprints (SBC444A)	4822 397 30245
Disc (65 min 1kHz) without no pause	4822 397 30155
Max. diameter disc (58.0 mm)	4822 397 60141
Torx screwdrivers	
Set (straigh)	4822 395 50145
Set (square)	4822 395 50132
13th order filter	4822 395 30204
Hexagon socket screw button (No. 1.5)	

1.4 DISMOUNTING INSTRUCTION

1. DISMOUNTING CDR LODER

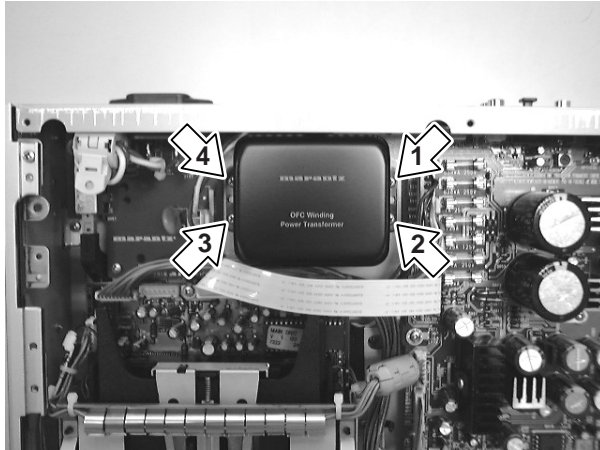

- 1) Remove 8 screws (**002D & 003D**) from the top cover.
- 2) Remove the top cover (**001D**).
- 3) Disconnect connector cables from **J801** and **JH04**.
- 4) Remove 4 screws (1-4), and remove the mains transformer (**L001**).

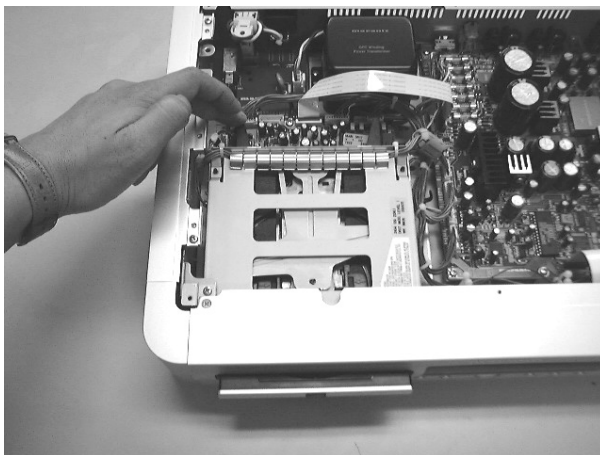

- 5) Come out (Open) the CD tray by manually.
- 6) Remove the CD tray lid (**050B+052B+062B**).

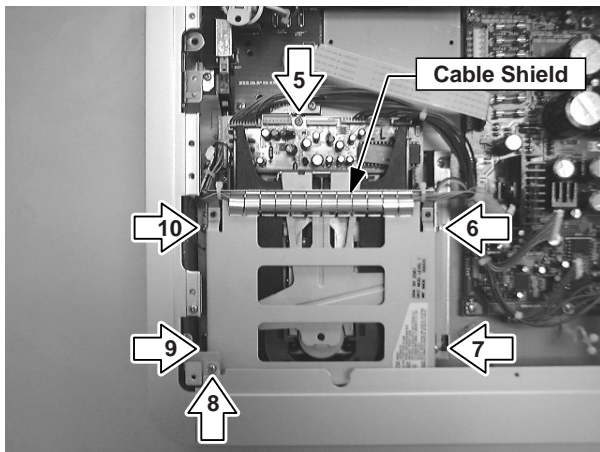

- 7) Remove screw (5) from the bracket (**004B**).
- 8) Remove 4 screws (6-10).
- 9) Disconnect all cables from connectors (**JF02, 1330, 1410, 1400, 1430** and **1440**).
- 10) Disconnect cables from connectors (**J891** and **J892**), and remove PCB **P816**.
- 11) Connect the cables from "TRAY MOTOR" to the connector **1104**.
- 12) Remove the cable shield (003X) from the top frame

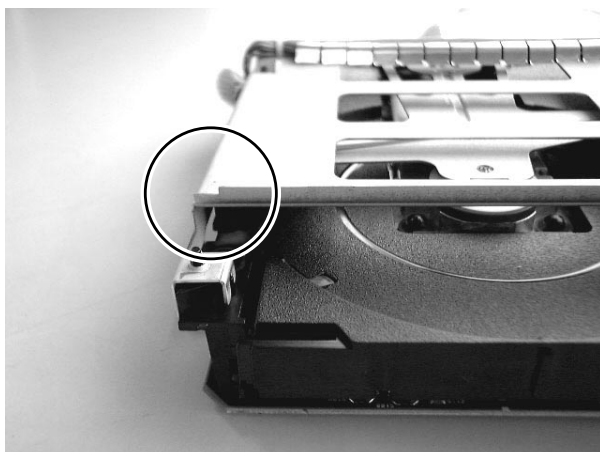

REMARK: When replace the CDR loader module CDRL3610' to the new one. It is necessary to cut left side of the top frame by the hand nibbler. (Height 2mm x Width 6mm)

2. DISMOUNTING ADDITIONAL CABLES

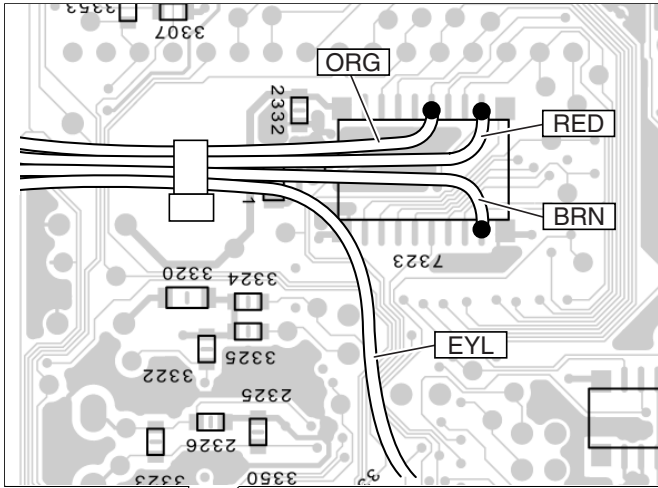

De-soldering and remove cables from the loader PCB.

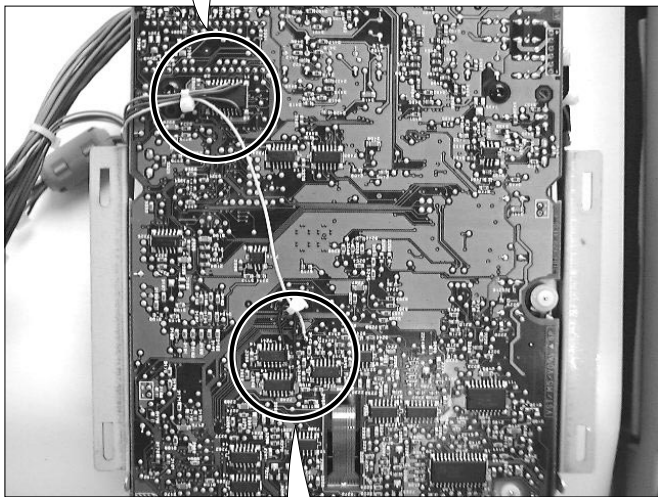

REMARK: When replace the CDR loader module CDRL3610' to the new one. It is necessary to add removed cables at same positions as follows;

- BROWM Pin 9 of IC7323
- RED Pin 12 of IC7323
- ORANGE Pin 15 of IC7323

- YELLOW Test Point beside 3149
- BLACK Pin 7 of IC7240 and Pin 7 of IC7241

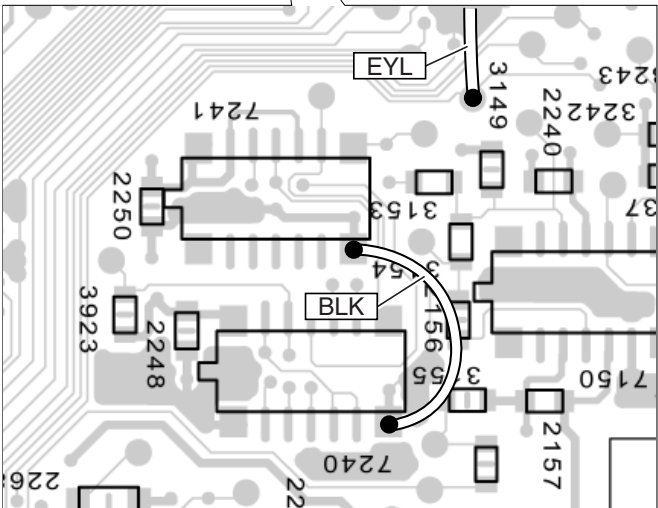

HDCD Technology

HDCD - High Definition Compatible Digital - is a patented process for delivering on digital media the full richness and detail of the original microphone feed. When listening to HDCD recordings, you will hear more dynamic range and very natural vocal and musical timbre. With HDCD, you get the body, depth and emotion of the original performance - not a flat, digital image.

HDCD encoded CDs sound better because they are encoded with 20 bits of real music information, compared to 16 bits for all other CDs. HDCD overcomes the limitations of the 16-bit CD format by using a sophisticated system to encode the additional the CD format.

In addition, HDCD Precision Digital Filtering has the benefit of improving the sound of all digital recordings. This means that the Marantz DR-17, equipped with HDCD, will improve the sound of all digital recordings, whether mastered with HDCD or not.

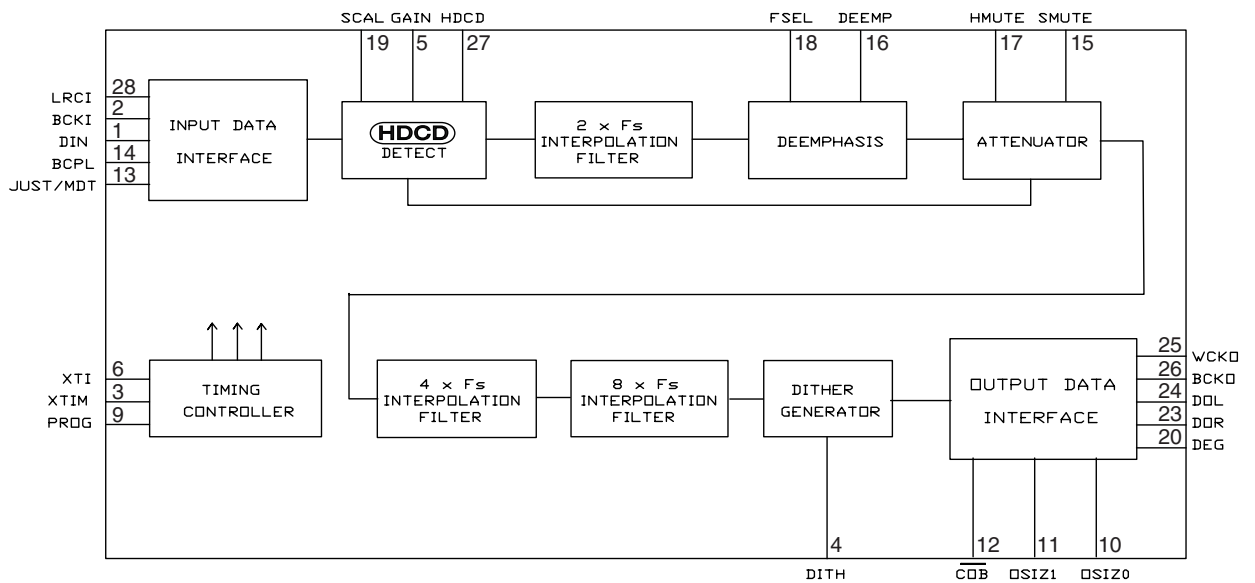

HDCD® and High Definition Compatible Digital®
are registered trademarks of Pacific Microsonics, Inc

1.5 BLOCK DIAGRAM

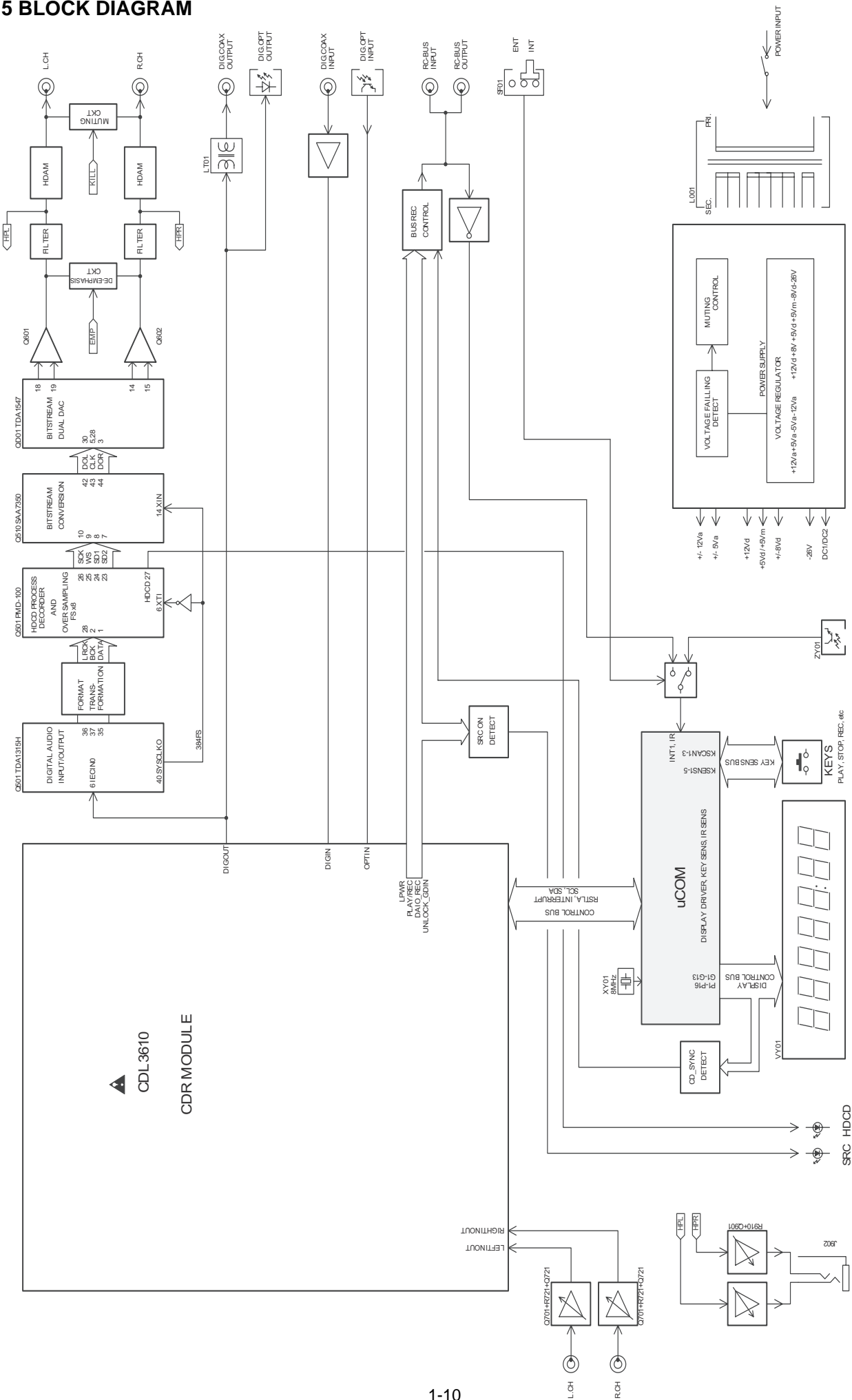

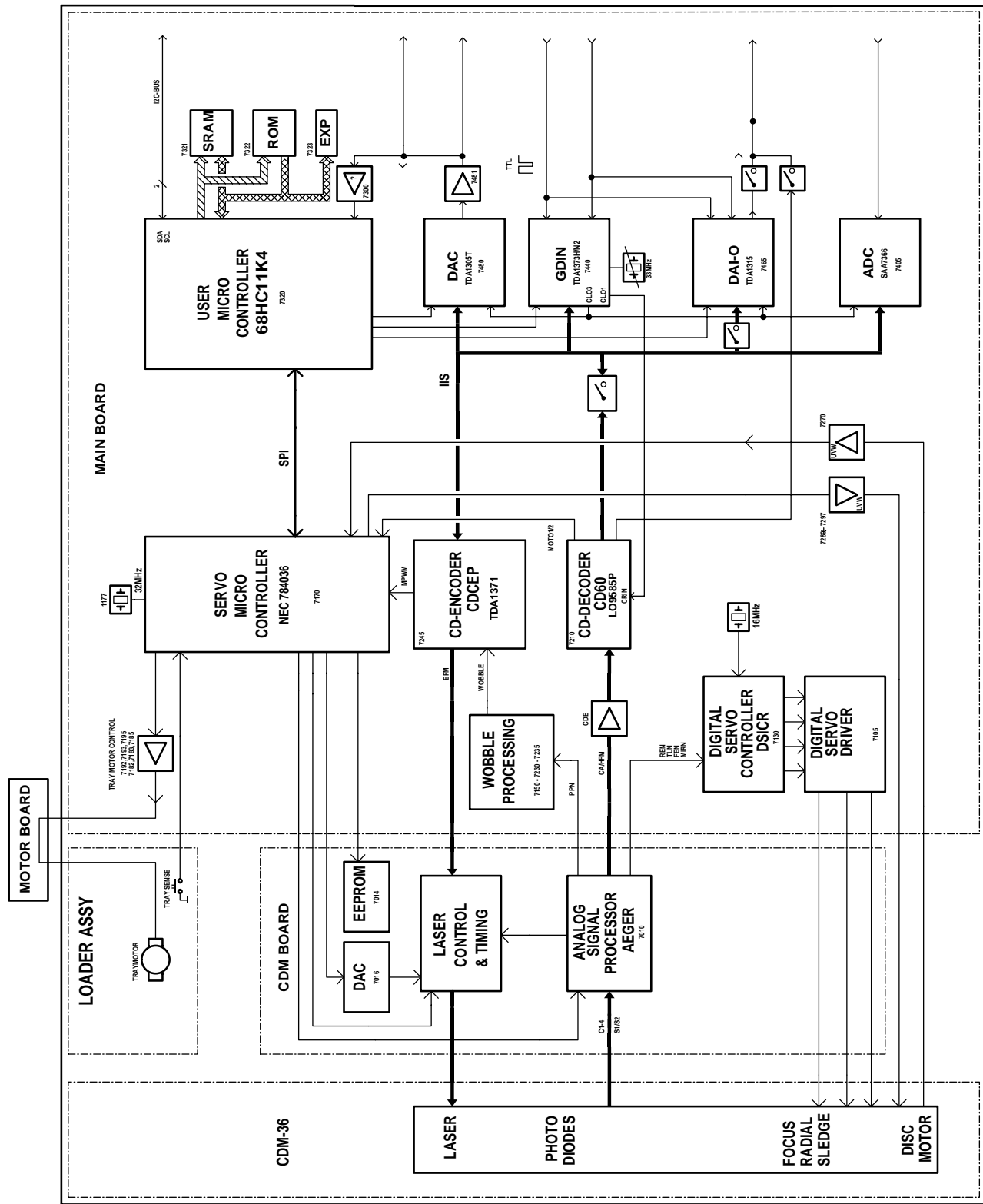

CDR LOADER

1.6 SERVICE TEST PROGRAM

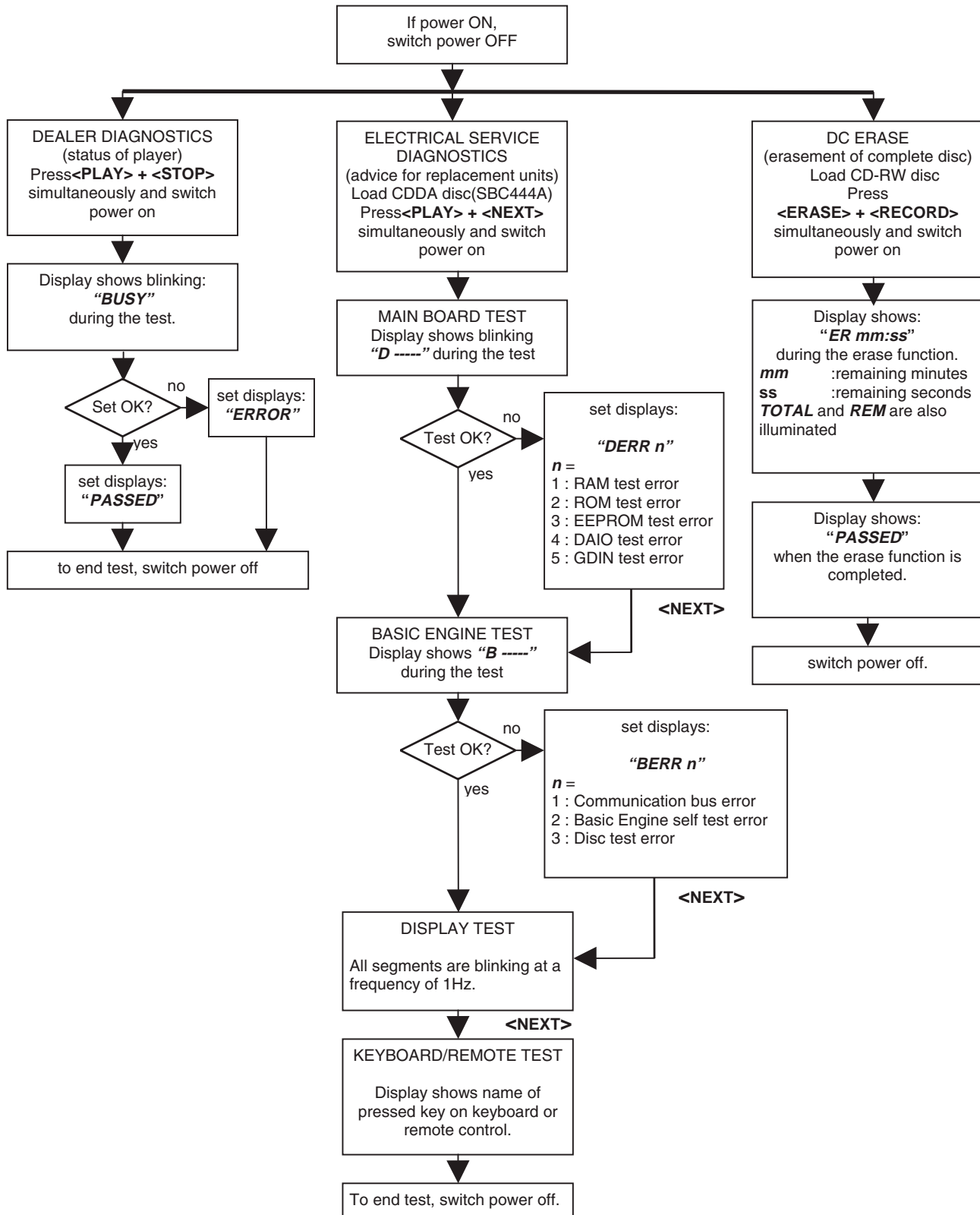

1.7 FAULTFINDING GUIDE

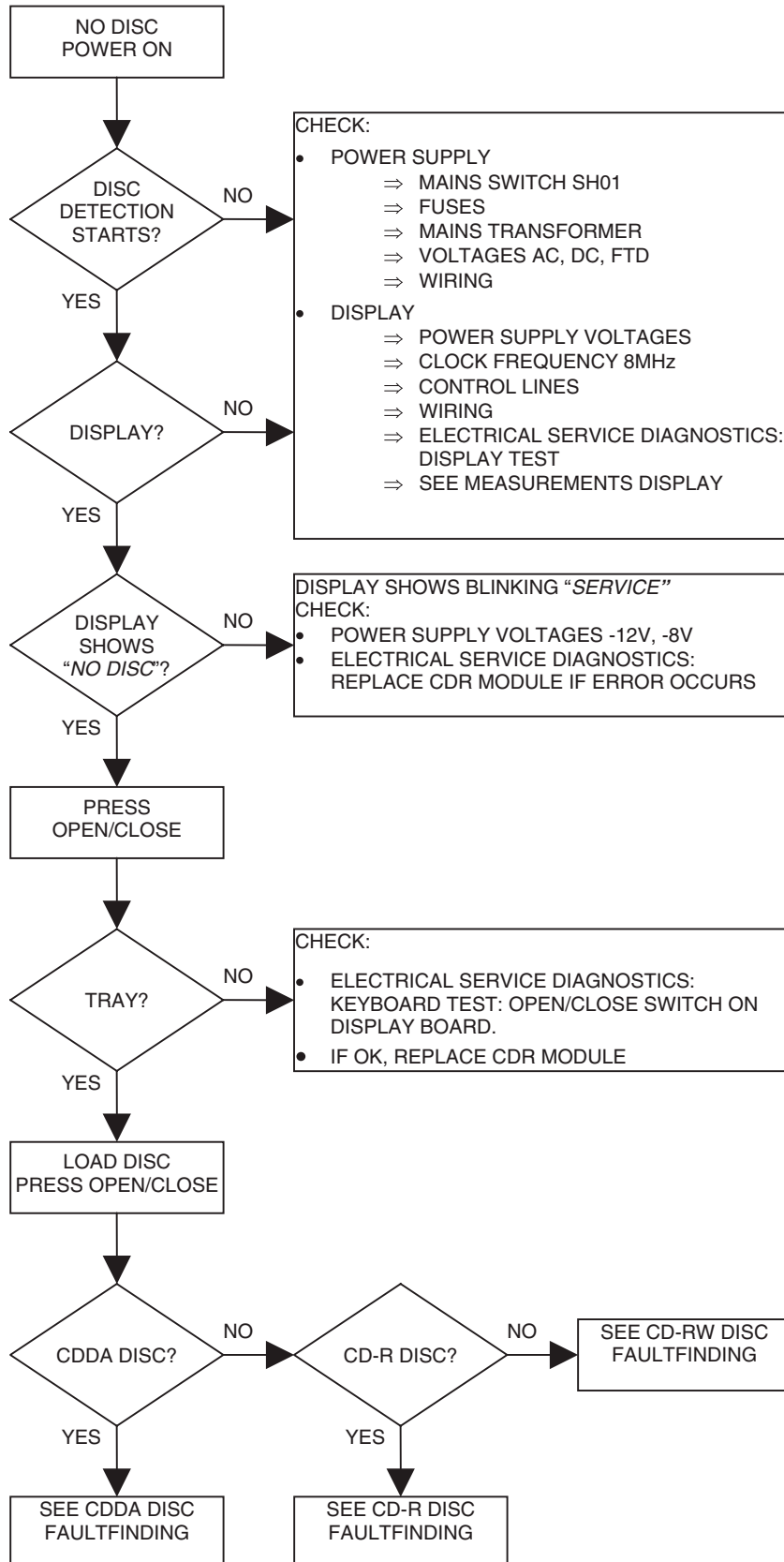

CDDA DISC FAULTFINDING GUIDE

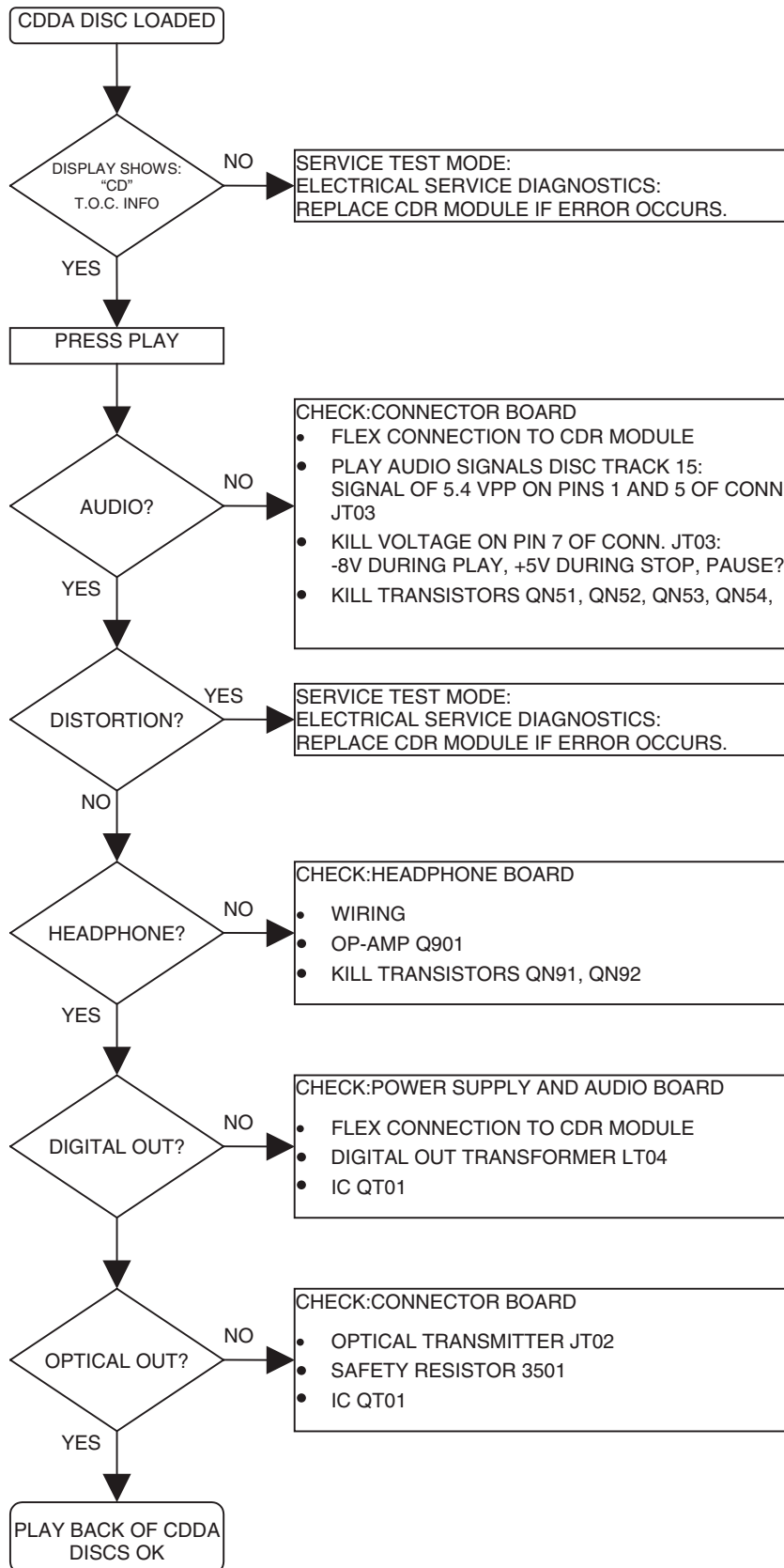

CD-R DISC FAULTFINDING

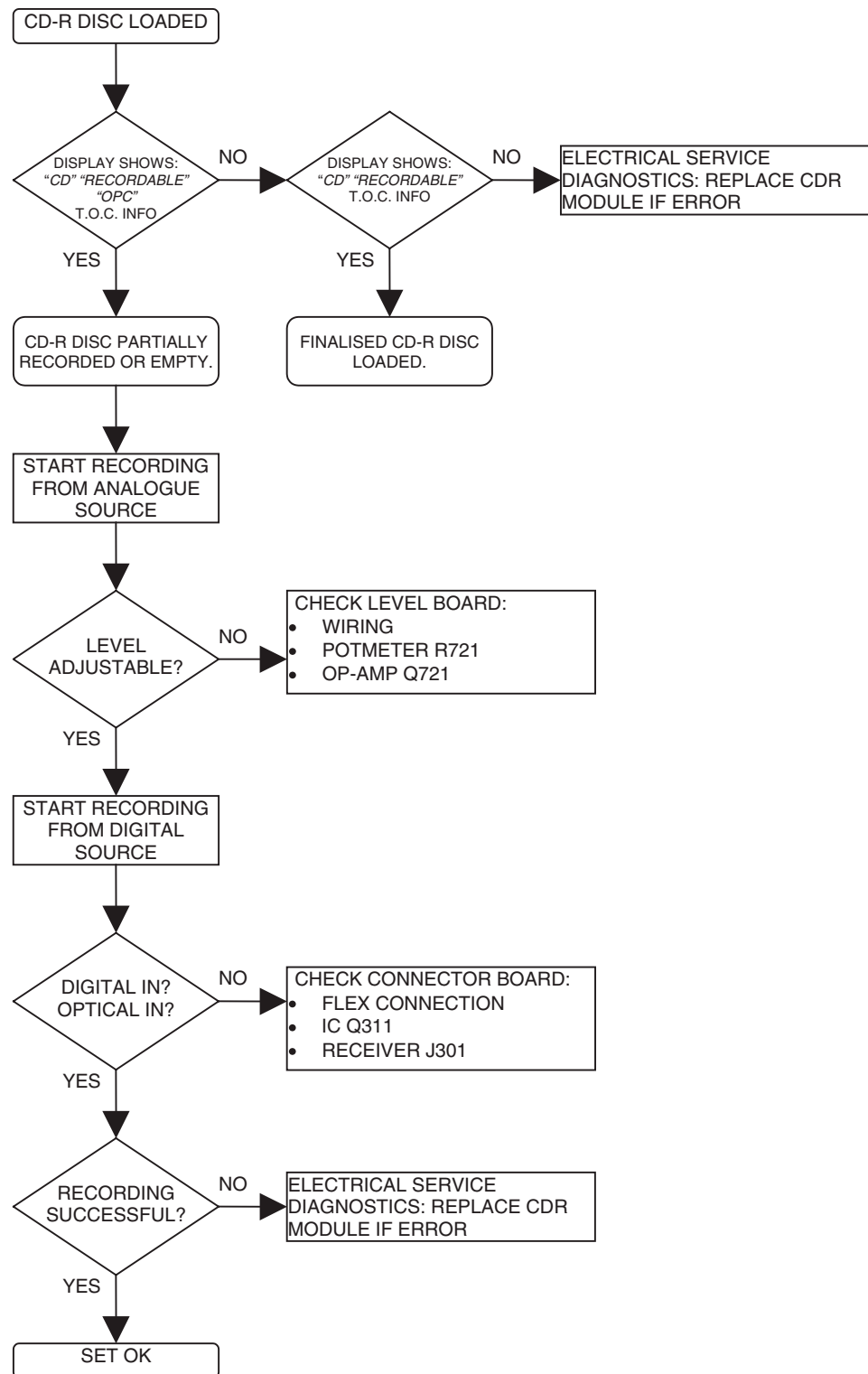

CD-RW DISC FAULTFINDING

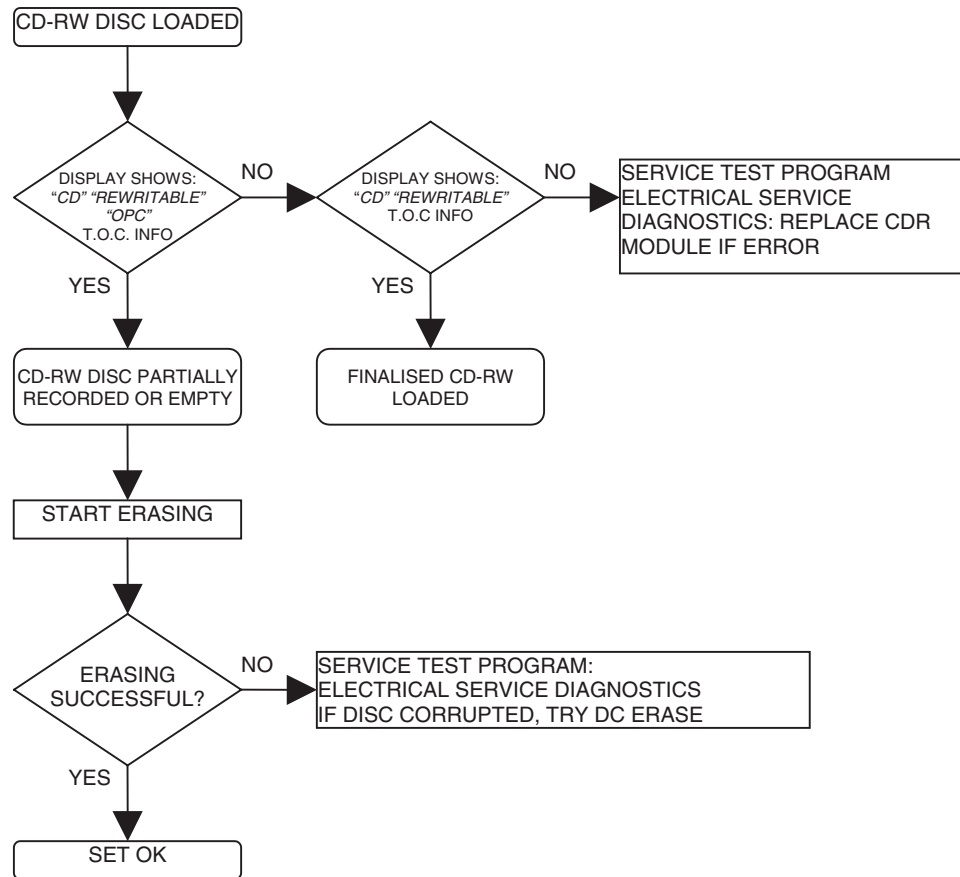

MEASUREMENTS DISPLAY PANEL

1. Measurement of voltage supplies.

Several voltages arrive at the display PCB.

Measurements and limits.

Voltage	Nominal value	Limits
VFTD	-26V	±5%
VDC1-DC2	3.5V	±10%
+5Vd	5V	±5%

2. Measurement of oscillator.

As clock driver for the display controller a resonator of 8MHz is used.

The clock frequency is available at pin 8 of the display controller.

Check the frequency of 8MHz ±5%.

3. Checking the control lines.

There are several lines which are inputs to the display controller and others which are outputs, these lines have to be checked to guarantee basic functionality.

RESETN:

This line should be kept low during power up for at least 3 machine cycles, with supply voltage within the operating range and oscillation stable. 1 machine cycle = $12 \times 1/F_c$ (8Mhz) Sec.

SDA and SCL:

The level on these two lines must be checked. When there is no communication they should have the 'High' level.

INTERRUPT:

The interrupt line is an output for the display controller. Check if this level is high after reset, no key pressed and no RC5 coming in.

Key matrix lines:

Check if at I/O port 4 of the controller all pins are high. (No keys pressed). (Pin 26 to 33). If not check respective pull-up resistors.

4. Operation of grid and segment control lines.

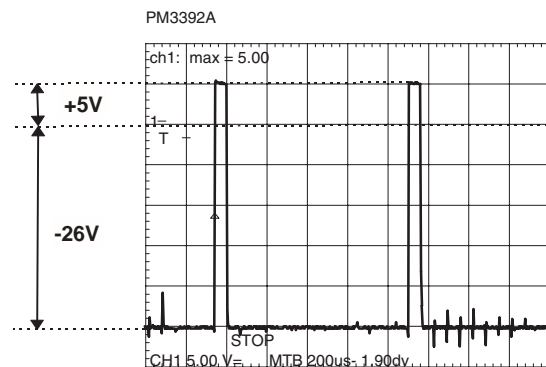

This figure shows the signal generated by the display processor on one of the grid lines. The level on the grid line changes from -26V to +5V.

The grid lines are scanned successively about every 950 μsec.

1.8 COMPONENT DESCRIPTIONS

Q301 : TDA1315H

SYMBOL	PIN	PADCELL	DESCRIPTION
RC _{fil}	1	E029	PLL loop filter input
V _{ref}	2	E029	decoupling internal reference voltage output
V _{DDA}	3	E008	analog supply voltage
V _{SSA}	4	E004	analog ground
IECIN1	5	E007	high sensitivity IEC input
IECIN0	6	IPP04	TTL level IEC input
IECSEL	7	IUP04	select IEC input 0 or 1 (0 = IECIN0; 1 = IECIN1); this input has an internal pull-up resistor
IECO	8	OPFH3	digital audio output for optical and transformer link
IECOEN	9	IUP04	digital audio output enable (0 = enabled; 1 = disabled/3-state); this input has an internal pull-up resistor
TESTB	10	IPP04	enable factory test input (0 = normal application; 1 = scan mode)
TESTC	11	IPP04	enable factory test input (0 = normal application; 1 = observation outputs)
UNLOCK	12	OPP41A	PLL out-of-lock (0 = not locked; 1 = locked); this output can drive an LED
$\overline{FS32}$	13	OPP41A	indicates sample frequency = 32 kHz (active LOW); this output can drive an LED
$\overline{FS44}$	14	OPP41A	indicates sample frequency = 44.1 kHz (active LOW); this output can drive an LED
$\overline{FS48}$	15	OPP41A	indicates sample frequency = 48 kHz (active LOW); this output can drive an LED
CHMODE	16	OPP41A	use of channel status block (0 = professional use; 1 = consumer use); this output can drive an LED
V _{DDD2}	17	E008	digital supply voltage 2
V _{SSD2}	18	E009	digital ground 2
RESET	19	IDP09	initialization after power-on, requires only an external capacitor connected to V _{DDD} ; this is a Schmitt-trigger input with an internal pull-down resistor
PD	20	IPP04	enable power-down input in the standby mode (0 = normal application; 1 = standby mode)
CTRLMODE	21	IUP04	select microcontroller/stand-alone mode (0 = microcontroller; 1 = stand-alone); this input has an internal pull-up resistor
LADDR	22	IPP04	microcontroller interface address switch input (0 = 000001; 1 = 000010)
LMODE	23	IPP09	microcontroller interface mode line input
LCLK	24	IPP09	microcontroller interface clock line input
LDATA	25	IOF24	microcontroller interface data line input/output
STROBE	26	IDP04	strobe for control register (active HIGH); this input has an internal pull-down resistor
UDAVAIL	27	OPF23	synchronization for output user data (0 = data available; 1 = no data)
TESTA	28	IPP04	enable factory (scan) test input (0 = normal application; 1 = test clock enable)
COPY	29	OPP41A	copyright status bit (0 = copyright asserted; 1 = no copyright asserted); this output can drive an LED
INVALID	30	IOD24	validity of audio sample input/output (0 = valid sample; 1 = invalid sample); this pin has an internal pull-down resistor
DEEM	31	OPF23	pre-emphasis output bit (0 = no pre-emphasis; 1 = pre-emphasis)
MUTE	32	IUP04	audio mute input (0 = permanent mute; 1 = mute on receive error); this pin has an internal pull-up resistor
I ² SSEL	33	IUP04	select auxiliary input or normal input in transmit mode
SDAUX	34	IPP04	auxiliary serial data input; I ² S-bus
SD	35	IOF24	serial audio data input/output; I ² S-bus
WS	36	IOF24	word select input/output; I ² S-bus
SCK	37	IOF29	serial audio clock input/output; I ² S-bus
I ² SOEN	38	IUP04	serial audio output enable (0 = enabled; 1 = disabled/3-state); this input has an internal pull-up resistor
SYSCLKI	39	IPP09	system clock input (transmit mode)
SYSCLKO	40	OPFA3	system clock output (receive mode)
V _{SSD1}	41	E009	digital ground 1
V _{DDD1}	42	E008	digital supply voltage 1
CLKSEL	43	IUP04	select system clock (0 = 384f _s ; 1 = 256f _s); this input has an internal pull-up resistor
RC _{int}	44	E029	integrating capacitor output

Q510 : PMD-100

PIN	SYMBOL	I/O	FUNCTION												
1	DIN	I	Serial data input												
2	BCKI	I	Bit clock input												
3	XTIM	I	Select system clock frequency Low = 256fs, High = 384fs												
4	DITH	I	Dither select Low = dither disable, High = dither added												
5	GAIN	O	Analog output stage gain Use only if Pin 19 is High Low = low gain, High = high gain (+6dB)												
6	XTI	I	System clock input												
7	VDD1	-	+5 volt power for filter												
8	VSS1	-	Ground												
9	PROG	I	Select program mode Low = Stand-alone, High = Program												
10	OSIZ0	I	<table border="1"> <thead> <tr> <th>16 Bits</th> <th>18Bits</th> <th>20Bits</th> <th>24Bits</th> </tr> </thead> <tbody> <tr> <td>0</td> <td>1</td> <td>0</td> <td>1</td> </tr> <tr> <td>0</td> <td>0</td> <td>1</td> <td>1</td> </tr> </tbody> </table>	16 Bits	18Bits	20Bits	24Bits	0	1	0	1	0	0	1	1
16 Bits	18Bits	20Bits		24Bits											
0	1	0	1												
0	0	1	1												
11	OSIZ1	I													
12	COB	I	Output data format Low = complementary offset binary High = 2's complement												
13	JUST	I	Input data justification Low = data assumed to be left justified up to 24 bits in length High = data right justified 16 bits												
14	BCPL	I	Input datalatching Low = input data latched on rising edge of BCKI High = input data latched on falling edge of BCKI												
15	SMUTE	I	Soft mute Low = off, High = on												
16	DEEMPH	I	De-emphasis filter Low = off, High = on												
17	HMUTE	I	Hard mute Low = off, High = on												
18	FSEL	I	De-emphasis filter Fs Low = 44.1kHz, High = 48kHz												
19	SCAL	I	Gain scaling Low = 6dB gain scaling is performed internally in the digital domain High = Analog output gain stage is set by pin 5 GAIN												
20	DG	O	DAC sample and hold deglitch signal												
21	VSS2	-	Ground (Common with VSS1)												
22	VDD2	-	+5V volt power for output interface												
23	DOR	O	Right channel serial data output												
24	DOL	O	Left channel serial data output												
25	WCKO	O	Word clock output												
26	BCKO	O	Bit clock output												
27	HDCD	O	HDCD encoding detect Low = no encoding, High = HDCD encoding input data (Output current rated at 12mA)												
28	LRCI	I	Word clock input												

QD01 : TDA1547

SYMBOL	PIN	DESCRIPTION
DGND	1	0 V digital supply
V _{DDD}	2	5 V digital supply for both channels
IN R	3	serial one-bit data input for the right channel
n.c.	4	pin not connected; should preferably be connected to digital ground
CLK R	5	clock input for the right channel
V _{DDD R}	6	5 V digital supply for the right channel; this voltage determines the internal logic HIGH level in the right channel
V _{SSD R}	7	-3.5 V digital supply for the right channel; this voltage determines the internal logic LOW level in the right channel
V _{ref R}	8	-4 V reference voltage for the right channel switched capacitor DAC
AGND DAC R	9	0 V reference voltage for the right channel switched capacitor DAC; this pin should be connected to analog ground
-DAC R	10	output from the right negative switched capacitor DAC; feedback connection for the right negative operational amplifier
+DAC R	11	output from the right positive switched capacitor DAC; feedback connection for the right positive operational amplifier
AGND R	12	0 V reference voltage for both right channel operational amplifiers
n.c.	13	pin not connected; should preferably be connected to analog ground
+OUT R	14	+ output of the switched capacitor operational amplifier
-OUT R	15	- output of the switched capacitor operational amplifier
V _{SSA}	16	-5 V analog supply
V _{DDA}	17	5 V analog supply
-OUT L	18	- output of the switched capacitor operational amplifier
+OUT L	19	+ output of the switched capacitor operational amplifier
n.c.	20	pin not connected; should preferably be connected to analog ground
AGND L	21	0 V reference voltage for both left channel operational amplifiers
+DAC L	22	output from the left positive switched capacitor DAC; feedback connection for the left positive operational amplifier
-DAC L	23	output from the left negative switched capacitor DAC; feedback connection for left negative operational amplifier
AGND DAC L	24	0 V reference voltage for the left channel switched capacitor DAC; this pin should be connected to analog ground
V _{ref L}	25	-4 V reference voltage for the left channel switched capacitor DAC
V _{SSD L}	26	-3.5 V digital supply for the left channel; this voltage determines the internal logic LOW level in the left channel
V _{DDD L}	27	5 V digital supply for the left channel; this voltage determines the internal logic HIGH level in the left channel
CLK L	28	clock input for the left channel
n.c.	29	pin not connected; should preferably be connected to digital ground
IN L	30	serial one-bit data input for the left channel
V _{SSD}	31	-5 V digital supply for both channels
V _{SUB}	32	-5 V substrate voltage

QY01 : TMP87CH74F

PIN	SYMBOL	PORT NAME	I/O	FUNCTION
1	OPEN	P02/SI1	-	
2	OPEN	P03	-	
3	OPEN	P04	-	
4	OPEN	P05	-	
5	OPEN	P06	-	
6	OPEN	P07	-	
7	VSS1	VSS	-	Ground
8	XOUT	XOUT	O	X'tal output
9	XIN	XIN	I	X'tal input
10	RESETIN	RESET	I/O	Reset input
11	OPEN	P22/XOUT	-	
12	OPEN	P21/XINT	-	
13	TEST1	TEST	I	Ground
14	OPEN	P20/INT5/STOP	-	
15	INT0	P10/INT0	I	Interrupt
16	INT1	P11/INT1	I	IR interrupt
17	OPEN	P12/TC2/PPG	-	
18	OPEN	P13/DVO	-	
19	OPEN	P14/TC4/PDO/PWM	-	
20	OPEN	P15/INT3/TC1	-	
21	OPEN	P16/INT2	-	
22	IR	P17/INT4/TC3	I	IR data input
23	SCL	P30/SCL/SIO	I	Serial clock input
24	SDA	P31/SDA/SO0	I	Serial data input
25	OPEN	P32/SCK0	-	
26	KSENS8	P40/AIN0	I	Key sens
27	KSENS7	P41/AIN1	I	Key sens
28	KSENS6	P42/AIN2	I	Key sens
29	KSENS5	P43/AIN3	I	Key sens
30	KSENS4	P44/AIN4	I	Key sens
31	KSENS3	P45/AIN5	I	Key sens
32	KSENS2	P46/AIN6	I	Key sens
33	KSENS1	P47/AIN7	I	Key sens
34	OPEN	P50/AIN10	-	
35	KSCAN3	P51/AIN11	O	Key scan
36	KSCAN2	P52/AIN12	O	Key scan
37	KSCAN1	P53/AIN13	O	Key scan
38	VASS	VASS	-	Ground
39	VAREF	VAREF	-	+5V
40	VDD	VDD	-	+5V
41	G13	P60/V0	O	Grid output
42	G12	P61/V1	O	Grid output
43	G11	P62/V2	O	Grid output
44	G10	P63/V3	O	Grid output
45	G9	P64/V4	O	Grid output
46	G8	P65/V5	O	Grid output
47	G7	P66/V6	O	Grid output
48	G6	P67/V7	O	Grid output
49	G5	P70/V8	O	Grid output
50	G4	P71/V9	O	Grid output
51	G3	P72/V10	O	Grid output
52	G2	P73/V11	O	Grid output
53	G1	P74/V12	O	Grid output
54	OPEN	P75/V13	-	
55	OPEN	P76/V14	-	
56	OPEN	P77/V15	-	
57	P1	P80/V16	O	Segment output
58	P2	P81/V17	O	Segment output
59	P3	P82/V18	O	Segment output
60	P4	P83/V19	O	Segment output
61	P5	P84/V20	O	Segment output
62	P6	P85/V21	O	Segment output
63	P7	P86/V22	O	Segment output
64	P8	P87/V23	O	Segment output
65	P9	P90/V24	O	Segment output
66	P10	P91/V25	O	Segment output
67	P11	P92/V26	O	Segment output
68	P12	P93/V27	O	Segment output
69	P13	P94/V28	O	Segment output
70	P14	P95/V29	O	Segment output
71	P15	P96/V30	O	Segment output
72	P16	P97/V31	O	Segment output
73	OPEN	PD0/V32	-	
74	OPEN	PD1/V33	-	
75	OPEN	PD2/V34	-	
76	OPEN	PD3/V35	-	
77	OPEN	PD4/V36	-	
78	VKK	VKK	-	Anode voltage for FTD
79	P0	P00/SCK1	I	Ground
80	P1	P01/SI1	I	Ground

QY01 : uPD6134

PIN	SYMBOL	PORT NAME	I/O	FUNCTION
1	OPEN	KIO06	-	
2	OPEN	KIO07	-	
3	KSENS	S0	I	Key sens
4	RCOUT	S1/LED	O	Data output
5	OPEN	REM	-	
6	VDD	VDD	-	+2.7V
7	XOUT	XOUT	O	Ground
8	XIN	XIN	I	X'tal output
9	GND	GND	-	X'tal input
10	RESET	RESET	I	Reset input
11	OPEN	KI0	-	
12	OPEN	KI1	-	
13	OPEN	KI2	-	
14	OPEN	KI3	-	
15	OPEN	KI/O0	-	
16	OPEN	KI/O1	-	
17	OPEN	KI/O2	-	
18	OPEN	KI/O3	-	
19	KSCAN	KI/O4	O	Key scan
20	OPEN	KI/O5	-	

Q520 : ASS7550AGP

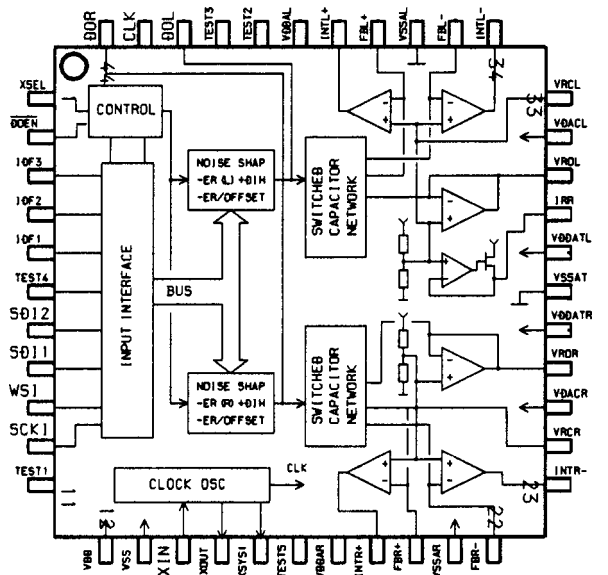

1.9 WIRING DIAGRAM

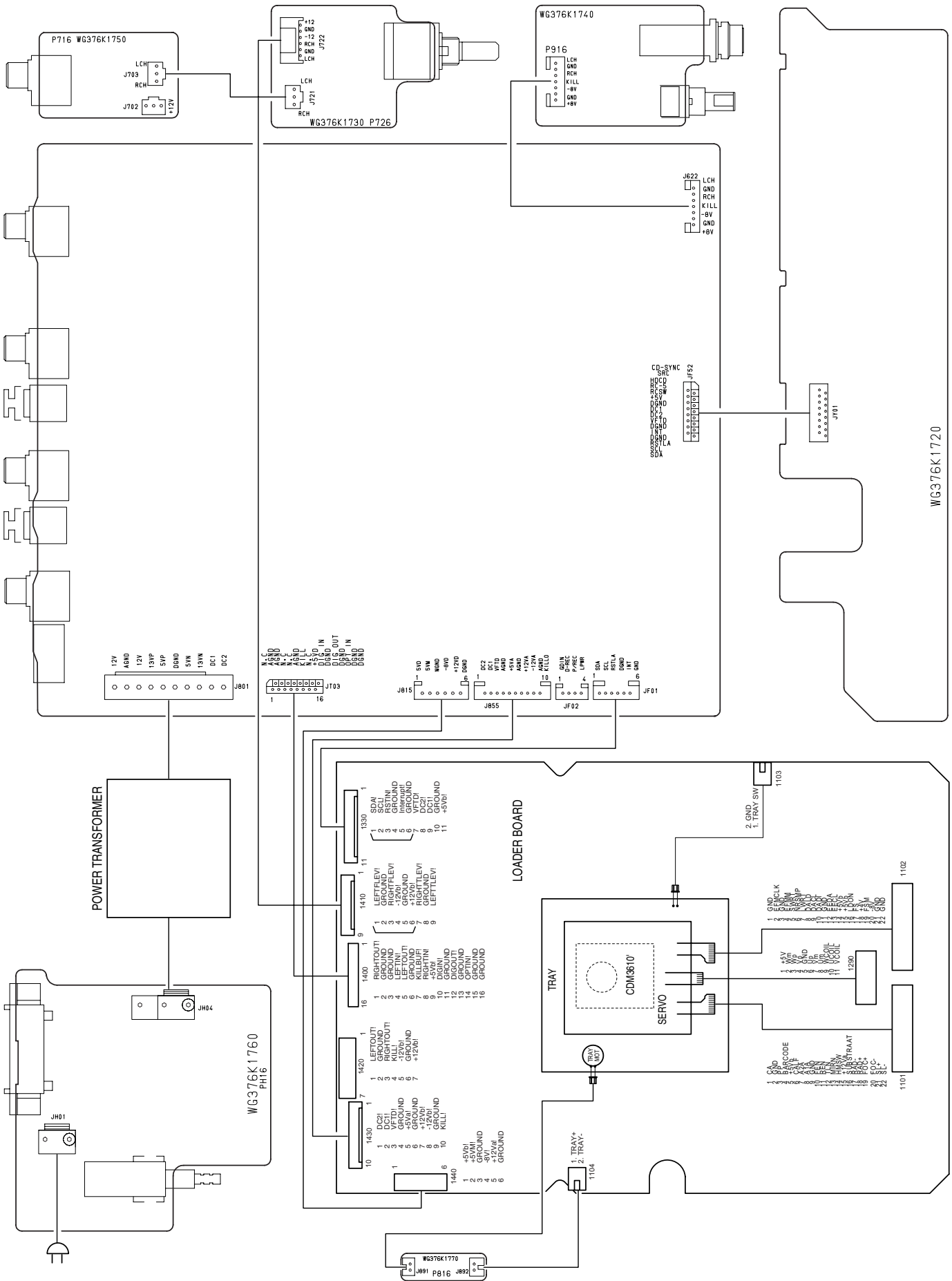

1.10 SCHEMATIC DIAGRAM AND PARTS LOCATION

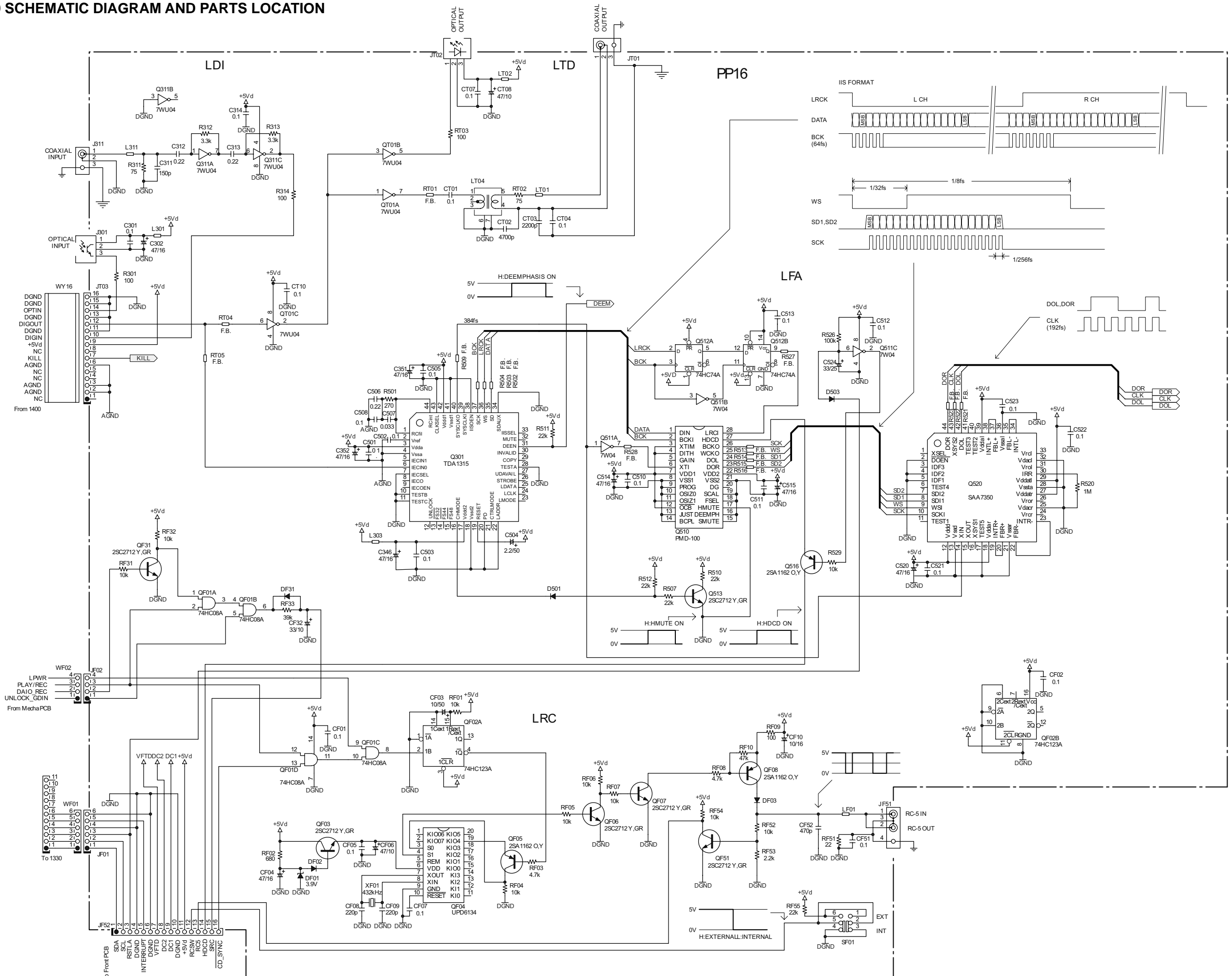

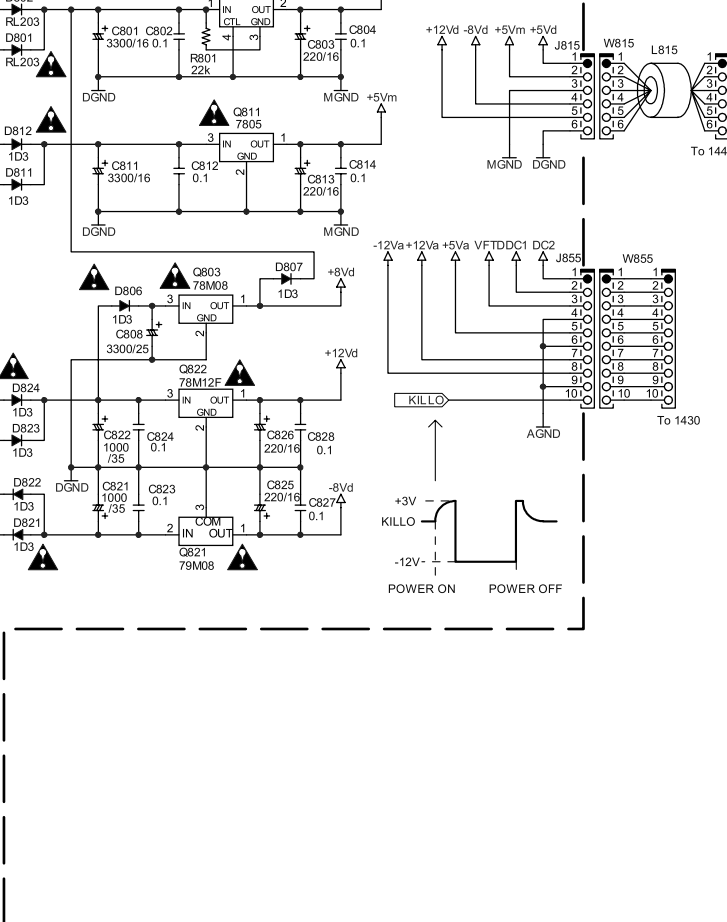
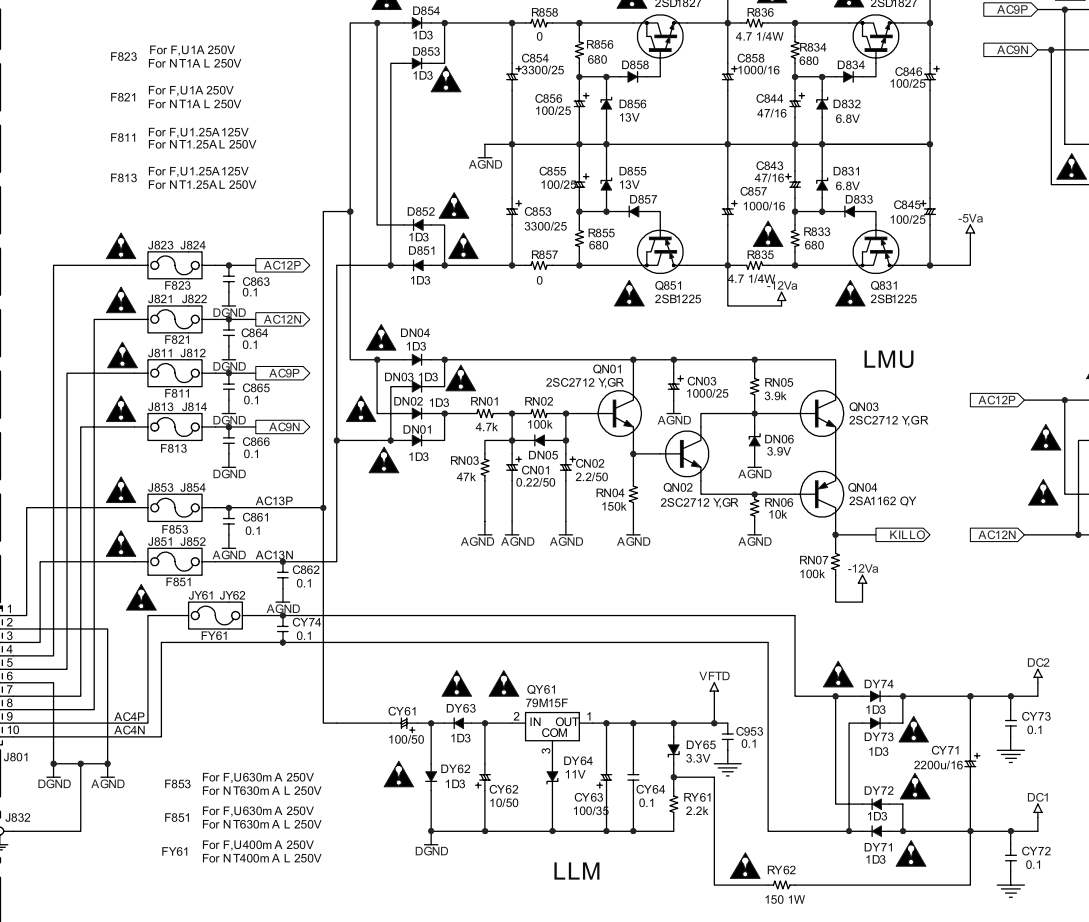
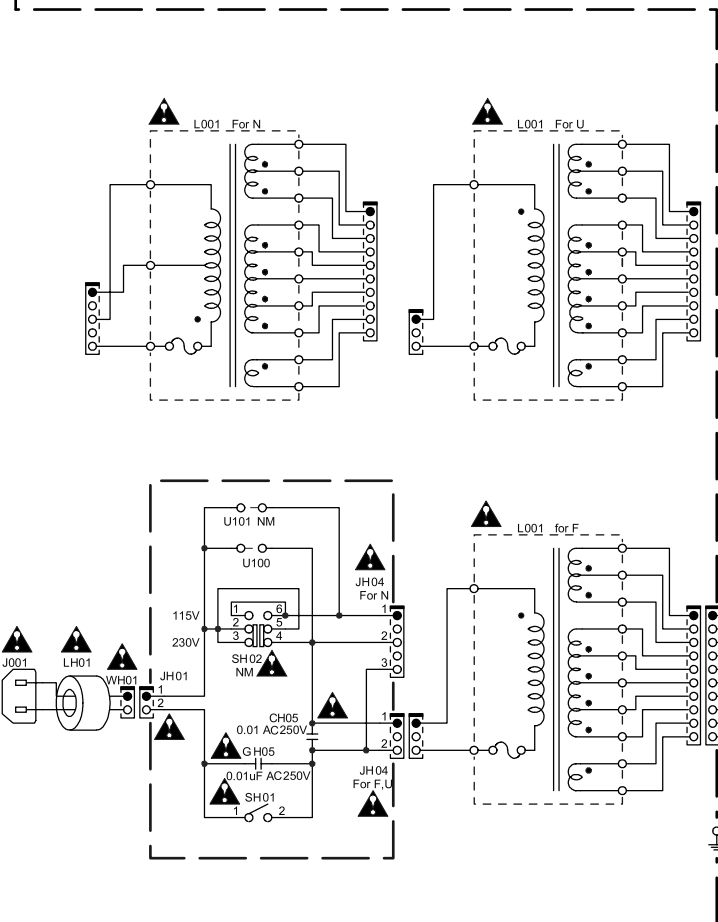
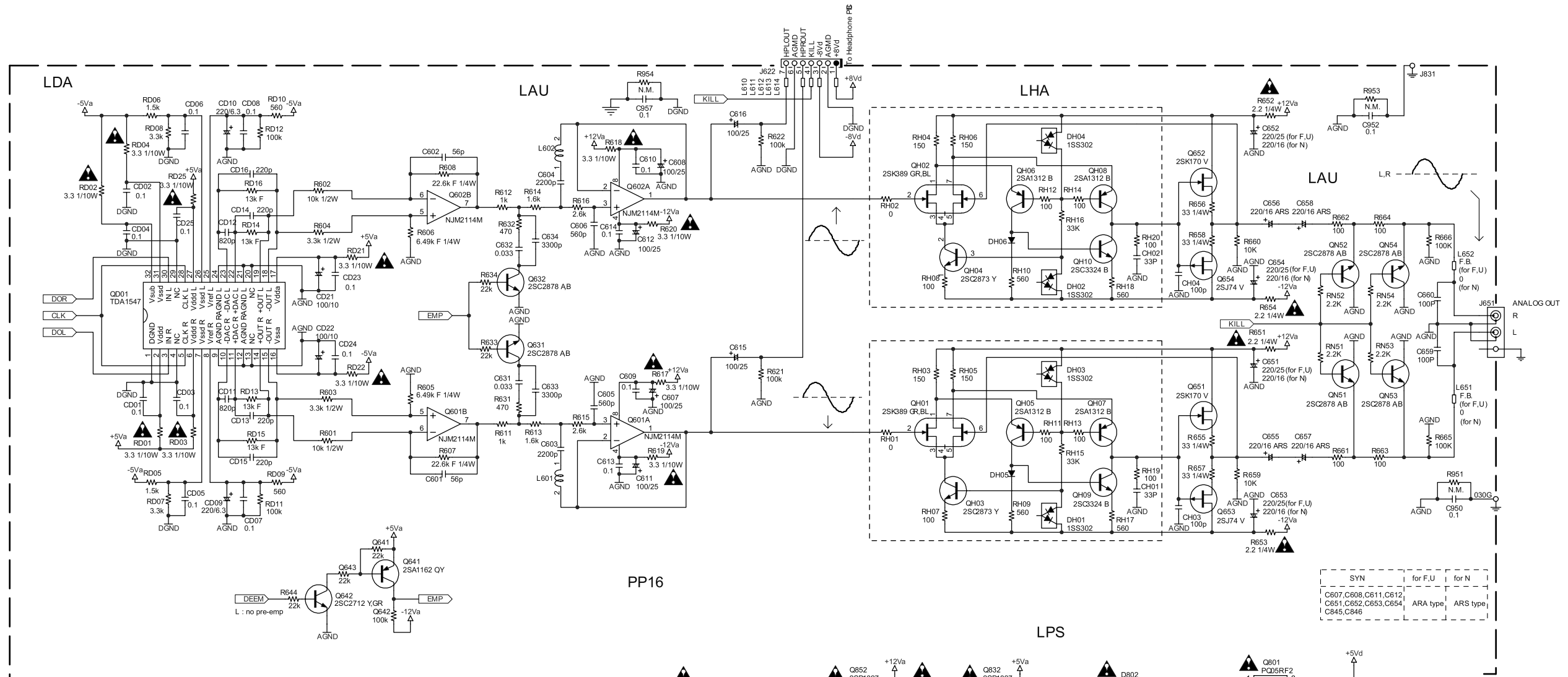

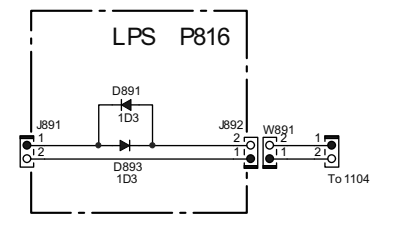
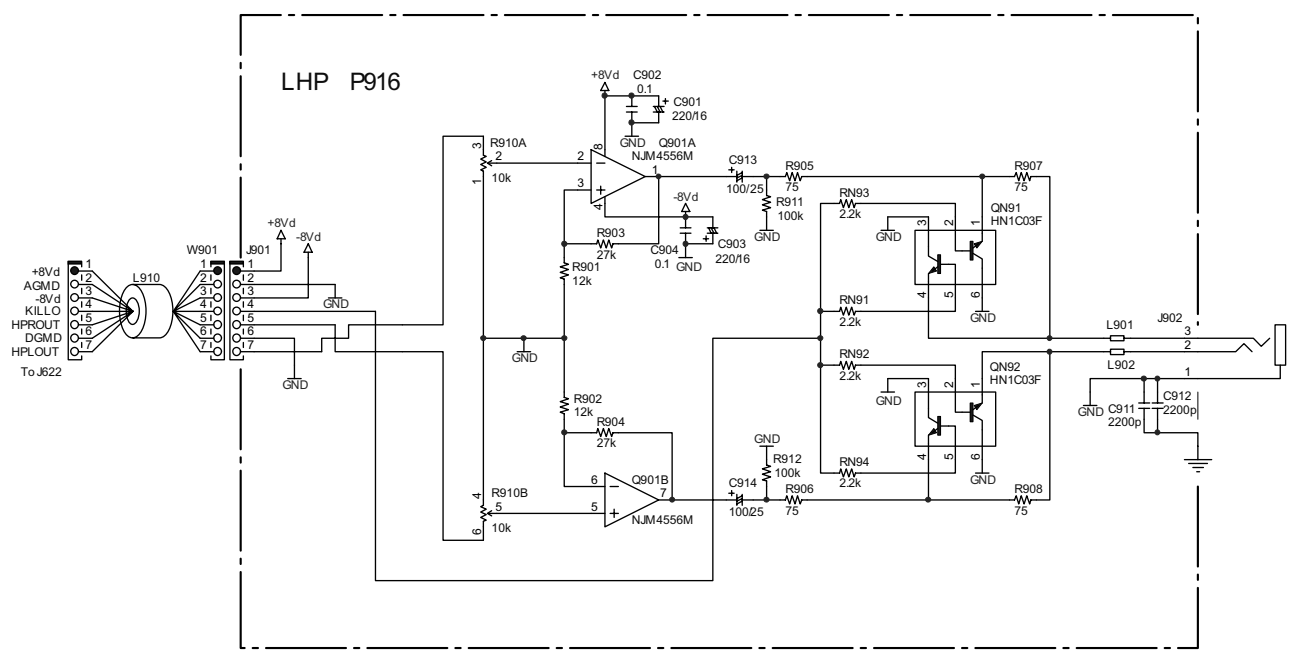
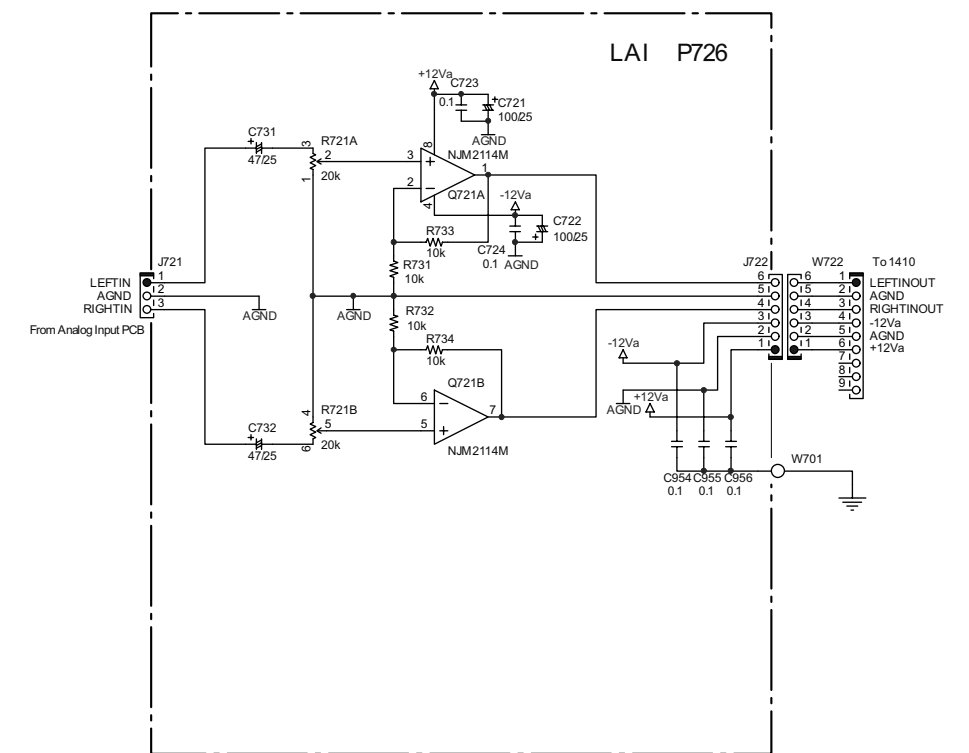
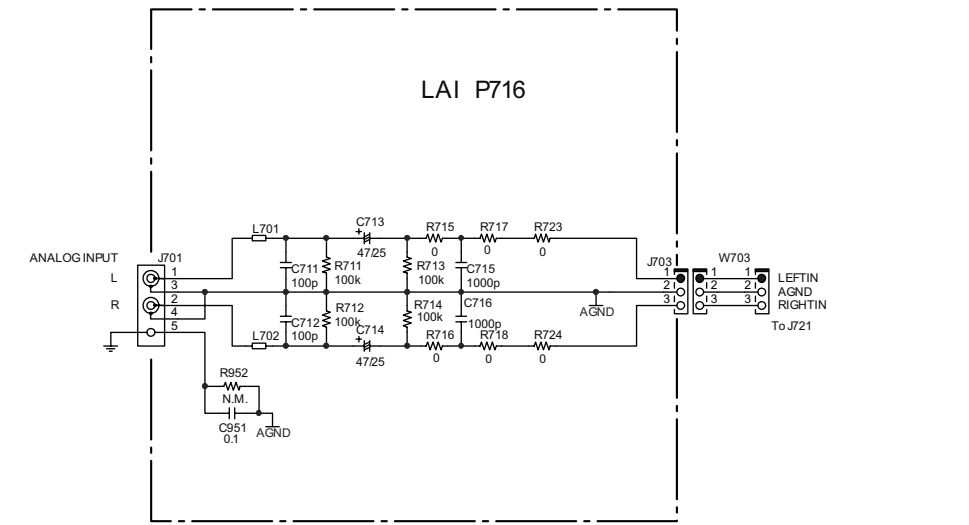
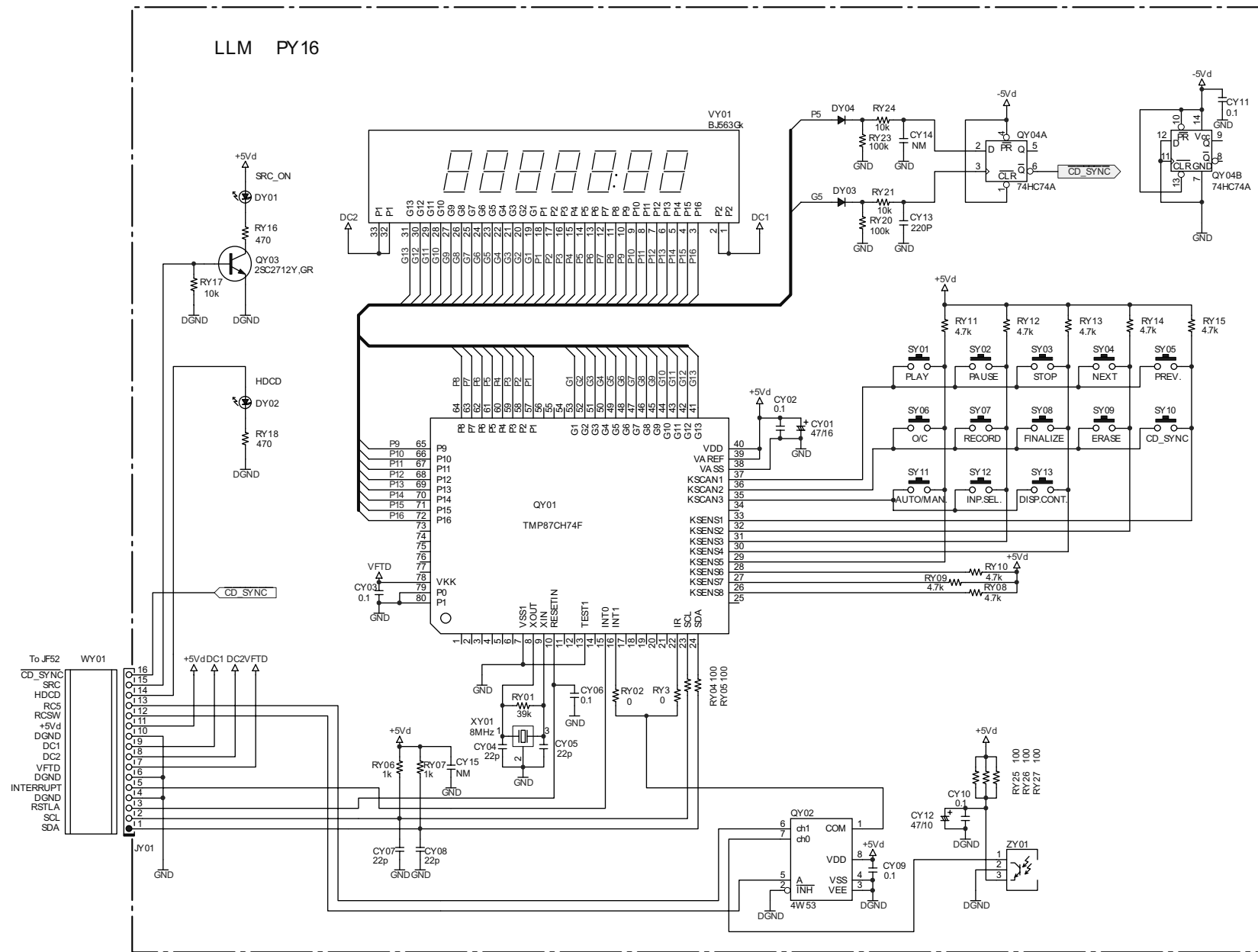

PH16

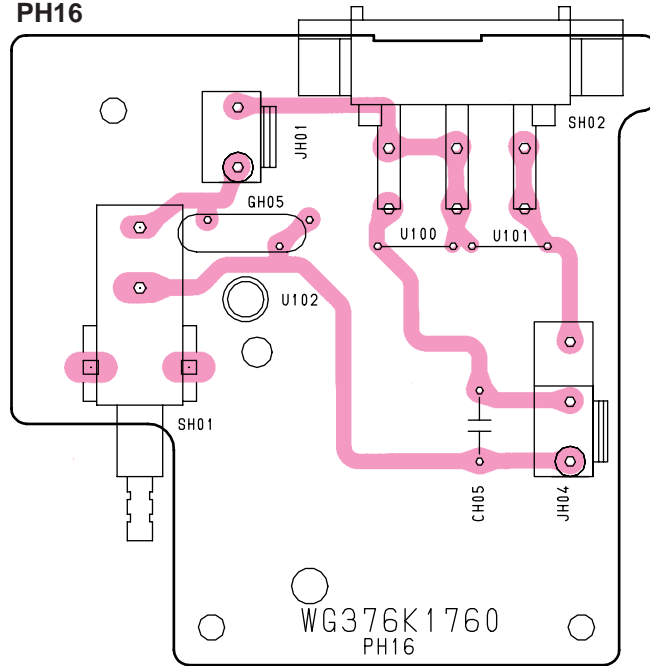

1.11 EXPLODED VIEW AND PARTS LIST

(VERS.:VERSION, U:U.S.A., F:JAPAN, K:FAR EAST, **:EUROPE)

(VERS.:VERSION, U:U.S.A., F:JAPAN, K:FAR EAST, **:EUROPE)

POS. NO	VERS. COLOR	PART NO. (FOR PCS)	DESCRIPTION	PART NO. (MJI)	POS. NO	VERS. COLOR	PART NO. (FOR PCS)	DESCRIPTION	PART NO. (MJI)
001B	GLD	9965 000 00553	FRONT PANEL ASSY GOLD	376K248550				PACKING	
001B	BLK	9965 000 00552	FRONT PANEL ASSY BLACK	376K248500	001S			PACKING CASE DR-17	376K801010
002B	GLD	9965 000 00555	FRONT PANEL AL GOLD	376K248110					
002B	BLK	9965 000 00554	FRONT PANEL AL BLACK	376K248010	001T	FN		USER GUIDE DR-17 F	376K851110
003B	GLD	4822 444 40853	CORNER COLUMN AL GOLD	318K063110	001T	N1B N1G	9965 000 00590	USER GUIDE DR-17 (9 LANG.)	376K851310
003B	BLK	4822 444 40852	CORNER COLUMN AL BLACK	318K063010	001T	U1B U1G		USER GUIDE DR-17 U	376K851250
015B	GLD	9965 000 00557	WINDOW,PINK	318K158120	008T		9965 000 00591	SHEET FOR CD-R CD-RW	376K851010
015B	BLK	9965 000 00556	WINDOW,BLUE	318K158020	009T	FN		QUICK USE GUIDE DR-17 F	376K851020
016B	GLD	9965 000 00559	BUSH,FOR TRAY OPENING	376K259110	010T	FN		FLY SEET FOR HDCD	376K851030
016B	BLK	9965 000 00558	BUSH,FOR TRAY OPENING	376K259010	010T	U1B U1G		FLY SEET FOR HDCD	376K851030
017B	GLD	9965 000 00561	FRONT PCB HOLDER GOLD	376K104110					
017B	BLK	9965 000 00560	FRONT PCB HOLDER BLACK	376K104010	001X		4822 466 12204	TRANSPORTATION PROTECTOR	376K269010
025B	GLD	9965 000 00563	BUTTON PLAY/STOP/PAUSE	362K270150					
025B	BLK	9965 000 00562	BUTTON PLAY/STOP/PAUSE	362K270050	T100		9965 000 00592	REMOTE CONTROLLER (RC-17DR)	ZK376K0010
026B	GLD	4822 410 70033	BUTTON OPEN/CLOSE GOLD	318K270130					
026B	BLK	4822 410 70028	BUTTON OPEN/CLOSE BLACK	318K270030					
027B	GLD	9965 000 00565	BUTTON ERASE GOLD	376K270110					
027B	BLK	9965 000 00564	BUTTON ERASE BLACK	376K270010	W002		4822 321 22611	RCA CONNECTIVE CODE GOLD	ZD01100010
028B	GLD	9965 000 00567	BUTTON DISPLAY GOLD	376K270120					
028B	BLK	9965 000 00566	BUTTON DISPLAY BLACK	376K270020	W003			RCA RC-5 CODE 0.9M	ZD00900100
035B	GLD	9965 000 00569	BUTTON REC GOLD	376K270140	W005		4822 321 22611	RCA CONNECTIVE CODE GOLD	ZD01100010
035B	BLK	9965 000 00568	BUTTON REC BLACK	376K270040					
036B	GLD	9965 000 00575	BUTTON CD SYNC GOLD	376K270160					
036B	BLK	9965 000 00574	BUTTON CD SYNC BLACK	376K270060					
045B	GLD	9965 000 00577	BUTTON POWER GOLD	376K270180					
045B	BLK	9965 000 00576	BUTTON POWER BLACK	376K270080					
047B	GLD	9965 000 00579	KNOB REC GOLD	376K154110					
047B	BLK	9965 000 00578	KNOB REC BLACK	376K154010					
048B	GLD	9965 000 00580	KNOB PHONE GOLD	284T154240					
048B	BLK	4822 411 20336	KNOB PHONE BLACK	284T154310					
050B	GLD	9965 000 00582	TRAY LID AL,W15 GOLD	376K063110					
050B	BLK	9965 000 00581	TRAY LID AL,W15 BLACK	376K063010					
052B		9965 000 00583	TRAY LID RETAINER	376K104060					
056B		9965 000 00584	LENS	351H355010					
062B		9965 000 00585	CD-R/CD-RW BADGE ON ESCUTCHEON	376K251010					
001D	GLD	9965 000 00587	TOP COVER AL GOLD (SLIT)	318K257140					
001D	BLK	9965 000 00586	TOP COVER AL BRACK (SLIT)	318K257040					
002D	GLD	4822 502 14425	SCR.THINHEAD 3X8NI	323S010020					
002D	BLK	4822 502 21693	SCR.THINHEAD 3X8BL	323S010030					
003D	GLD	4822 502 14462	SCR.THINHEAD 3X5NI	318K010020					
003D	BLK	4822 502 14461	SCR.THINHEAD 3X5BL	318K010030					
010D	GLD	4822 444 40855	SIDE PANEL GOLD	318K249110					
010D	BLK	4822 444 40854	SIDE PANEL BLACK	318K249010					
010G		4822 462 42134	LEG	291K057010					
030G		9965 000 00588	POWER SW.LINK	376K121010					
001M		3104 129 21361	CDR MECHA ASSY	376K304500					
▲ J001		4822 265 11399	2P MAINS INLET SOT-16C	YJ04002360					
▲ L001	FN		EI-5735 100V 50/60HZ	TS15746010					
▲ L001	N1B N1G	9965 000 00598	EI-5735 230V 50HZ	TS15746020					
▲ L001	U1B U1G		EI-5735 120V 60HZ	TS15746040					
▲ W001	FN		MAINS CORD MITI DC-302-J 125V	ZC01802080					
▲ W001	N1B N1G	4822 321 11439	MAINS CORD 10A 250V CLASS-2	ZC01803080					
▲ W001	U1B U1G		MAINS CORD UL/CSA 10A 125V	ZC01803100					

1.12 ELECTRICAL PARTS LIST

ASSIGNMENT OF COMMON PARTS CODES.

RESISTORS

R*** : 1) GD05 x x x 140, Carbon film fixed resistor, ±5% 1/4W
 R*** : 2) GD05 x x x 160, Carbon film fixed resistor, ±5% 1/6W
 ① Resistance value

Examples
 ① Resistance value
 0.1Ω 001 10Ω 100 1kΩ 102 100kΩ 104
 0.5Ω 005 18Ω 180 2.7kΩ 272 680kΩ 684
 1Ω 010 100Ω 101 10kΩ 103 1MΩ 105
 6.8Ω 068 390Ω 391 22kΩ 223 4.7MΩ 475

Note : Please distinguish 1/4W from 1/6W by the shape of parts used actually.

CAPACITORS

C*** : CERAMIC CAP.
 3) DD1 x x x x 370, Ceramic capacitor
 Disc type
 Temp.coef. P350~N1000, 50V
 ③ Capacity value
 ② Tolerance

Examples
 ② Tolerance (Capacity deviation)
 ±0.25 pF 0
 ±0.5 pF 1
 ±5 % 5
 Tolerance of COMMON PARTS handled here are as follows :
 0.5 pF - 5 pF ± 0.25 pF
 6 pF - 10 pF ± 0.5 pF
 12 pF - 560 pF ± 5 %

③ Capacity value
 0.5 pF 005 3 pF 030 100 pF 101
 1 pF 010 10 pF 100 220 pF 221
 1.5 pF 015 47 pF 470 560 pF 561

C*** : CERAMIC CAP.
 4) DK16 x x x 300, High dielectric constant ceramic capacitor
 Disc type
 Temp.chara. 2B4, 50V
 ④ Capacity value

Examples
 ④ Capacity value
 100 pF 101 1000 pF 102 10000 pF 103
 470 pF 471 2200 pF 222

C*** : 5) ELECTROLY CAP. (Z), 6) FILM CAP. (F)
 5) EA x x x x x 10, Electrolytic capacitor
 One-way lead type, Tolerance ±20%
 ⑥ Working voltage
 ⑤ Capacity value

Examples
 ⑤ Capacity value
 0.1 μF 104 4.7 μF 475 100 μF 107
 0.33 μF 334 10 μF 106 330 μF 337
 1 μF 105 22 μF 226 1100 μF 118
 2200 μF 228
 ⑥ Working voltage
 6.3 V 006 25 V 025
 10 V 010 35 V 035
 16 V 016 50 V 050

6) DF15 x x x 350 Plastic film capacitor
 DF15 x x x 310 One-way type, Mylar ±5% 50V
 DF16 x x x 310 Plastic film capacitor
 One-way type, Mylar ±10% 50V
 ⑦ Capacity value

Examples
 ⑦ Capacity value
 0.001 μF (1000 pF) 102 0.1 μF 104
 0.0018 μF 182 0.56 μF 564
 0.01 μF 103 1 μF 105
 0.015 μF 153

NOTE 1) The above CODES (R***, R***, C***, C*** and C***) are omitted on the schematic diagram in some case.
 2) On the occasion, be confirmed the common parts on the parts list.
 3) Refer to "Common Parts List" for the other common parts (RI05, DD4, DK4).

NOTE ON SAFETY FOR FUSIBLE RESIST OR :

The suppliers and their type numbers of fusible resistors are as follows ;

1. KOA Corporation
 Part No.(MJI) Type No.(KOA) Description
 NH05 x x x 140 RF25S x x x x Ω J ±5% (1/4W)
 NH05 x x x 120 RF50S x x x x Ω J ±5% (1/2W)
 NH85 x x x 110 RF73B2A x x x x Ω J ±5% (1/10W)
 NH95 x x x 140 RF73B2E x x x x Ω J ±5% (1/4W)
 * Resistance value Resistance value(0.1Ω - 10k Ω)

2. Matsushita Electronic Components Co., Ltd
 Part No.(MJI) Type No.(MEC) Description
 NF05 x x x 140 ERD-2FCJ x x x (±5% 1/4W)
 RF05 x x x 140 ERD-2FCG x x x (±2% 1/4W)
 NF02 x x x 140 ERD-2FCG x x x
 RF02 x x x 140 * Resistance value
 Examples
 * Resistance value
 0.1Ω 001 10Ω 100 1kΩ 102 100kΩ 104
 0.5Ω 005 18Ω 180 2.7kΩ 272 680kΩ 684
 1Ω 010 100Ω 101 10kΩ 103 1MΩ 105
 6.8Ω 068 390Ω 391 22kΩ 223 4.7MΩ 475

ABBREVIATION AND MARKS			
ANT.	: ANTENNA	BATT.	: BATTERY
CAP.	: CAPACITOR	CER.	: CERAMIC
CONN.	: CONNECTING	DIG.	: DIGITAL
HP	: HEADPHONE	MIC.	: MICROPHONE
μ-PRO	: MICROPROCESSOR	REC.	: RECORDING
RES.	: RESISTOR	SPK	: SPEAKER
SW	: SWITCH	TRANSF.	: TRANSFORMER
TRIM.	: TRIMMING	TRS.	: TRANSISTOR
VAR.	: VARIABLE	X' TAL	: CRYSTAL

NOTE ON SAFETY:

Symbol ▲ Fire or electrical shock hazard. Only original parts should be used to replaced any part marked with symbol ▲ Any other component substitution (other than original type), may increase risk of fire or electrical shock hazard.

安全上の注意 :

▲がついている部品は、安全上重要な部品です。必ず指定されている部品番号の部品を使用して下さい。

(VERS.:VERSION, U:U.S.A., F:JAPAN, K:FAR EAST, **:EUROPE)

POS. NO	VERS. COLOR	PART NO. (FOR PCS)	DESCRIPTION	PART NO. (MJI)
▲ CH05		4822 122 33276	PH16-POWER SWITCH	
▲ GH05		4822 121 43732	CIRCUIT BOARD	
			CER. CAP 0.01mF 250V M	DK17103840
			FILM CAP 0.01mF 250V M	DF77103500
▲ SH01		4822 276 13364	POWER SW. TV-3	SP01011990
			PP16-MAIN CIRCUIT BOARD	
			CAPACITORS	
CF01		4822 126 13837	CER. 0.1μF K CHIP	DK96104200
CF03		5322 124 21731	ELECT 10μF 50V	OA10605020
CF04		4822 124 41539	ELECT 47μF 16V	OA47601620
CF05		4822 126 13837	CER. 0.1μF K CHIP	DK96104200
CF06		4822 124 22275	ELECT 47μF 10V	OA47601020
CF07		4822 126 13837	CER. 0.1μF K CHIP	DK96104200
CF08		4822 122 10172	CER. 220pF K CHIP	DK96221300
CF09		4822 122 10172	CER. 220pF K CHIP	DK96221300
CF10		4822 124 90352	ELECT 10μF 16V	OA10601620
CF32		9965 000 00606	ELECT 33μF 10V	OA33601020
CF51		4822 126 13837	CER. 0.1μF K CHIP	DK96104200
CF52		4822 126 11568	CER. 470pF K CHIP	DK96471300
CD01				
∫		4822 126 13837	CER. 0.1μF K CHIP	DK96104200
CD08				
CD09		4822 124 41537	ELECT 220μF 6.3V	OA22700620
CD10		4822 124 41537	ELECT 220μF 6.3V	OA22700620
CD11		4822 123 30363	FILM 820pF 100WV CHIP	DF95821510
CD12		4822 123 30363	FILM 820pF 100WV CHIP	DF95821510
CD13				
∫		4822 123 30359	FILM 220pF 100WV CHIP	DF95221510
CD16				
CD21		4822 124 90353	ELECT 100μF 10V	OA10701020
CD22		4822 124 90353	ELECT 100μF 10V	OA10701020
CD23		4822 126 13837	CER. 0.1μF K CHIP	DK96104200
CD24		4822 126 13837	CER. 0.1μF K CHIP	DK96104200
CD25		4822 126 13837	CER. 0.1μF K CHIP	DK96104200
CH01		4822 126 11671	CER. 33pF 50V J CHIP	DD95330300
CH02		4822 126 11671	CER. 33pF 50V J CHIP	DD95330300
CH03		4822 122 31765	CER. 100pF 50V J CHIP	DD95101300
CH04		4822 122 31765	CER. 100pF 50V J CHIP	DD95101300
CN01		4822 124 22703	ELECT 0.22μF 50V	OA22405020
CN02		4822 124 40763	ELECT 2.2μF 50V M	OA22505020
CN03		4822 124 22723	ELECT 1000μF 25V M	OA10802520
CT01		4822 126 13837	CER. 0.1μF K CHIP	DK96104200
CT02		4822 126 11685	CER. 4700pF 50V K CHIP	DK96472300
CT03		4822 126 12339	CER. 2200pF 50V K CHIP	DK96222300
CT04		4822 126 13837	CER. 0.1μF K CHIP	DK96104200
CT07		4822 126 13837	CER. 0.1μF K CHIP	DK96104200
CT08		4822 124 22275	ELECT 47μF 10V	OA47601020
CT10		4822 126 13837	CER. 0.1μF K CHIP	DK96104200
CY61		4822 124 90355	ELECT 100μF 50V M	OA10705020
CY62		5322 124 21731	ELECT 10μF 50V M	OA10605020
CY63		4822 124 41536	ELECT 100μF 35V	OA10703520
CY64		4822 122 40617	CER. 0.1μF 50V Z	DD38104010
CY71		4822 124 40723	ELECT 2200μF 16V	OA22801620
CY72		4822 126 11558	CER. 0.1μF 25V M	DA17104110
CY73		4822 126 11558	CER. 0.1μF 25V M	DA17104110
CY74		4822 122 40617	CER. 0.1μF 50V Z	DD38104010
C301		4822 126 13837	CER. 0.1μF K CHIP	DK96104200
C302		4822 124 41539	ELECT 47μF 16V M	OA47601620
C311		4822 122 33753	CER. 150pF 50V J CHIP	DD95151300
C312		9965 000 00599	CER. 0.22μF 10V K CHIP	DK96224200
C313		9965 000 00599	CER. 0.22μF 10V K CHIP	DK96224200

(VERS.:VERSION, U:U.S.A., F:JAPAN, K:FAR EAST, **:EUROPE)

POS. NO	VERS. COLOR	PART NO. (FOR PCS)	DESCRIPTION	PART NO. (MJI)
C314		4822 126 13837	CER. 0.1μF K CHIP	DK96104200
C346		4822 124 41539	ELECT 47μF 16V	OA47601620
C351		4822 124 41539	ELECT 47μF 16V	OA47601620
C352		4822 124 41539	ELECT 47μF 16V M	OA47601620
C501		4822 126 13837	CER. 0.1μF K CHIP	DK96104200
C502		4822 126 13837	CER. 0.1μF K CHIP	DK96104200
C503		4822 126 13837	CER. 0.1μF K CHIP	DK96104200
C504		4822 124 40763	ELECT 2.2μF 50V	OA22505020
C505		4822 126 13837	CER. 0.1μF K CHIP	DK96104200
C506		9965 000 00599	CER. 0.22μF 10V K CHIP	DK96224200
C507		4822 126 12105	CER. 0.033μF K CHIP	DK96333200
C508		4822 126 13837	CER. 0.1μF K CHIP	DK96104200
C510				
∫		4822 126 13837	CER. 0.1μF K CHIP	DK96104200
C513				
C514		4822 124 41539	ELECT 47μF 16V M	OA47601620
C515		4822 124 41539	ELECT 47μF 16V M	OA47601620
C520		4822 124 41539	ELECT 47μF 16V	OA47601620
C521		4822 126 13837	CER. 0.1μF K CHIP	DK96104200
C522		4822 126 13837	CER. 0.1μF K CHIP	DK96104200
C523		4822 126 13837	CER. 0.1μF K CHIP	DK96104200
C524		9965 000 00600	ELECT 9933μF 25V M	OA33602520
C601		4822 123 30361	MICA 56pF 500WV CHIP	DF95560500
C602		4822 123 30361	MICA 56pF 500WV CHIP	DF95560500
C603		4822 123 30387	FILM 2200pF J CHIP	DF95222030
C604		4822 123 30387	FILM 2200pF J CHIP	DF95222030
C605		4822 123 30362	FILM 560pF 100WV CHIP	DF95561510
C606		4822 123 30362	FILM 560pF 100WV CHIP	DF95561510
C607	FN	4822 124 22238	ELECT 100μF 25V	OA10702550
C607	N1B N1G	4822 124 80119	ELECT 100μF 25V	OA10702540
C607	U1B U1G	4822 124 22238	ELECT 100μF 25V	OA10702550
C608	FN	4822 124 22238	ELECT 100μF 25V	OA10702550
C608	N1B N1G	4822 124 80119	ELECT 100μF 25V	OA10702540
C608	U1B U1G	4822 124 22238	ELECT 100μF 25V	OA10702550
C609		4822 126 11687	CER. 0.1μF Z CHIP	DK98104200
C610		4822 126 11687	CER. 0.1μF Z CHIP	DK98104200
C611	FN	4822 124 22238	ELECT 100μF 25V	OA10702550
C611	N1B N1G	4822 124 80119	ELECT 100μF 25V	OA10702540
C611	U1B U1G	4822 124 22238	ELECT 100μF 25V	OA10702550
C612	FN	4822 124 22238	ELECT 100μF 25V	OA10702550
C612	N1B N1G	4822 124 80119	ELECT 100μF 25V	OA10702540
C612	U1B U1G	4822 124 22238	ELECT 100μF 25V	OA10702550
C613		4822 126 11687	CER. 0.1μF Z CHIP	DK98104200
C614		4822 126 11687	CER. 0.1μF Z CHIP	DK98104200
C615		4822 124 90354	ELECT 100μF 25V	OA10701620
C616		4822 124 90354	ELECT 100μF 25V	OA10701620
C651	FN	4822 124 90051	ELECT 220μF 25V	OA22702550
C651	N1B N1G	4822 124 80123	ELECT 220μF 25V	OA22701640
C651	U1B U1G	4822 124 90051	ELECT 220μF 25V	OA22702550
C652	FN	4822 124 90051	ELECT 220μF 25V	OA22702550
C652	N1B N1G	4822 124 80123	ELECT 220μF 25V	OA22701640
C652	U1B U1G	4822 124 90051	ELECT 220μF 25V	OA22702550
C653	FN	4822 124 90051	ELECT 220μF 25V	OA22702550
C653	N1B N1G	4822 124 80123	ELECT 220μF 16V	OA22701640
C653	U1B U1G	4822 124 90051	ELECT 220μF 25V	OA22702550
C654	FN	4822 124 90051	ELECT 220μF 25V	OA22702550
C654	N1B N1G	4822 124 80123	ELECT 220μF 16V	OA22701640
C654	U1B U1G	4822 124 90051	ELECT 220μF 25V	OA22702550
C655		4822 124 80123	ELECT 220μF 16V	OA22701640
C656		4822 124 80123	ELECT 220μF 16V	OA22701640
C657		4822 124 80123	ELECT 220μF 16V	OA22701640
C658		4822 124 80123	ELECT 220μF 16V	OA22701640

(VERS.:VERSION, U:U.S.A., F:JAPAN, K:FAR EAST, **:EUROPE)

POS. NO	VERS. COLOR	PART NO. (FOR PCS)	DESCRIPTION	PART NO. (MJI)
C811		4822 124 90388	ELECT 3300 μ F 16V	OA33801620
C812		4822 122 40617	CER. 0.1 μ F 50V Z	DD38104010
C813		4822 124 12404	ELECT 220 μ F 16V	OA22701620
C814		4822 126 13837	CER. 0.1 μ F K CHIP	DK96104200
C821		4822 124 90356	ELECT 1000 μ F 35V	OA10803520
C822		4822 124 90356	ELECT 1000 μ F 35V	OA10803520
C823		4822 122 40617	CER. 0.1 μ F 50V Z	DD38104010
C824		4822 122 40617	CER. 0.1 μ F 50V Z	DD38104010
C825		4822 124 12404	ELECT 220 μ F 16V	OA22701620
C826		4822 124 12404	ELECT 220 μ F 16V	OA22701620
C827		4822 126 11687	CER. 0.1 μ F Z CHIP	DK98104200
C828		4822 126 11687	CER. 0.1 μ F Z CHIP	DK98104200
C843		4822 124 41539	ELECT 47 μ F 16V	OA47601620
C844		4822 124 41539	ELECT 47 F 16V	OA47601620
C845	FN	4822 124 22238	ELECT 100 μ F 25V	OA10702550
C845	N1B N1G	4822 124 80119	ELECT 100 μ F 25V	OA10702540
C845	U1B U1G	4822 124 22238	ELECT 100 μ F 25V	OA10702550
C846	FN	4822 124 22238	ELECT 100 μ F 25V	OA10702550
C846	N1B N1G	4822 124 80119	ELECT 100 μ F 25V	OA10702540
C846	U1B U1G	4822 124 22238	ELECT 100 μ F 25V	OA10702550
C853		9965 000 00605	ELECT 3300 μ F 25V	OB33802510
C854		9965 000 00605	ELECT 3300 μ F 25V	OB33802510
C855		4822 124 41535	ELECT 100 μ F 25V	OA10702520
C856		4822 124 41535	ELECT 100 μ F 25V	OA10702520
C857		4822 124 22722	ELECT 1000 μ F 16V	OA10801620
C858		4822 124 22722	ELECT 1000 μ F 16V	OA10801620
C861				
∫		4822 122 40617	CER. 0.1 μ F 50V Z	DD38104010
C866				
C950		4822 122 40617	CER. 0.1 μ F 50V Z	DD38104010
C952		4822 122 40617	CER. 0.1 μ F 50V Z	DD38104010
C953		4822 122 40617	CER. 0.1 μ F 50V Z	DD38104010
C957		4822 122 40617	CER. 0.1 μ F 50V Z	DD38104010
			DIODES	
DF01		4822 130 80132	ZENNER NTJ3.9B 3.9V	HD30391000
DF02		4822 130 32362	SUBSTITUTE	HD20002000
DF03		4822 130 32362	SUBSTITUTE	HD20002000
DF31		4822 130 32362	1SS176,MA165,1SS254 30V 0.1A	HD20002000
▲ DN01				
∫		4822 130 82421	1D3 1A/200V	HD20002710
▲ DN04				
DN05		4822 130 32362	SUBSTITUTE	HD20002000
DN06		4822 130 80132	ZENER 3.9V EQUIVALENT	HD30391000
DH01				
∫		4822 130 81324	CHIP DIODE 1SS302	HZ20018050
DH04				
DH05		4822 130 32362	SUBSTITUTE	HD20002000
DH06		4822 130 32362	SUBSTITUTE	HD20002000
▲ DY62		4822 130 82421	1D3 1A/200V	HD20002710
▲ DY63		4822 130 82421	1D3 1A/200V	HD20002710
DY64		4822 130 34488	ZENNER NTJ11B 11V	HD31101000
DY65		5322 130 31504	ZENER 3.3V EQUIVALENT	HD30331000
▲ DY71				
∫		4822 130 82421	1D3 1A/200V	HD20002710
▲ DY74				
D501		4822 130 32362	1SS176,MA165,1SS254 30V 0.1A	HD20002000
D503		4822 130 32362	1SS176,MA165,1SS254 30V 0.1A	HD20002000
▲ D801		4822 130 32968	RL203-M11 2A-200V	HD20001710
▲ D802		4822 130 32968	RL203-M11 2A-200V	HD20001710
D806		4822 130 82421	1D3 1A/200V	HD20002710
D807		4822 130 82421	1D3 1A/200V	HD20002710
▲ D811		4822 130 82421	1D3 1A/200V	HD20002710

(VERS.:VERSION, U:U.S.A., F:JAPAN, K:FAR EAST, **:EUROPE)

POS. NO	VERS. COLOR	PART NO. (FOR PCS)	DESCRIPTION	PART NO. (MJI)
▲ D812		4822 130 82421	1D3 1A/200V	HD20002710
▲ D821				
∫		4822 130 82421	1D3 1A/200V	HD20002710
▲ D824				
D831		4822 130 80318	ZENNER NTJ6.8C 6.8V	HD30681000
D832		4822 130 80318	ZENNER NTJ6.8C 6.8V	HD30681000
D833		4822 130 32362	SUBSTITUTE	HD20002000
D834		4822 130 32362	SUBSTITUTE	HD20002000
▲ D851				
∫		4822 130 82421	1D3 1A/200V	HD20002710
▲ D854				
D855		4822 130 80623	ZENNER NTJ13B 13.0V	HD31301000
D856		4822 130 80623	ZENNER NTJ13B 13.0V	HD31301000
D857		4822 130 32362	SUBSTITUTE	HD20002000
D858		4822 130 32362	SUBSTITUTE	HD20002000
			FUSES	
▲ FY61	FN		400MA 250V UL,CSA	FS10040350
▲ FY61	N1B N1G	4822 070 34001	T400MA 250V BS LISTED	FS10040850
▲ FY61	U1B U1G		400MA 250V UL,CSA	FS10040350
▲ F811	FN		1.25A 125V	FS10125350
▲ F811	N1B N1G	4822 070 31252	1.25A 250V	FS10125850
▲ F811	U1B U1G		1.25A 125V	FS10125350
▲ F813	FN		1.25A 125V	FS10125350
▲ F813	N1B N1G	4822 070 31252	1.25A 250V	FS10125850
▲ F813	U1B U1G		1.25A 125V	FS10125350
▲ F821	FN		1 A 250V	FS10100350
▲ F821	N1B N1G	4822 070 31002	1 A 250V	FS10100850
▲ F821	U1B U1G		1 A 250V	FS10100350
▲ F823	FN		1 A 250V	FS10100350
▲ F823	N1B N1G	4822 070 31002	1 A 250V	FS10100850
▲ F823	U1B U1G		1 A 250V	FS10100350
▲ F851	FN		630MA 250V	FS10063350
▲ F851	N1B N1G	4822 070 36301	630MA 250V	FS10063850
▲ F851	U1B U1G		630MA 250V	FS10063350
▲ F853	FN		630 A 250V	FS10063350
▲ F853	N1B N1G	4822 070 36301	630 A 250V	FS10063850
▲ F853	U1B U1G		630 A 250V	FS10063350
			TRANSISTORS	
QD01		4822 209 31355	TDA1547(DAC7)	HC10066490
QF01		4822 209 63379	TC74HC08AF	HC700800Z0
QF02		5322 209 16682	TC74HC123AF	HC712300Z0
QF03		4822 130 61355	2SC2712 0,Y	HX327122A0
QF05		4822 130 61311	2SA1162 0,Y	HX111622A0
QF06		4822 130 61355	2SC2712 0,Y	HX327122A0
QF07		4822 130 61355	2SC2712 0,Y	HX327122A0
QF08		4822 130 61311	2SA1162 0,Y	HX111622A0
QF31		4822 130 61355	2SC2712 0,Y	HX327122A0
QF51		4822 130 61355	2SC2712 0,Y	HX327122A0
QH01		4822 130 42843	2SK389 GR OR BL	HF203892A0
QH02		4822 130 42843	2SK389 GR OR BL	HF203892A0
QH03		4822 130 61425	CHIP 2SC2873 Y	HX328731B0
QH04		4822 130 61425	CHIP 2SC2873 Y	HX328731B0
QH05				
∫		4822 130 63928	CHIP 2SA1312	HX113121B0
QH08				
QH09		4822 130 63929	CHIP 2SC3324	HX333241B0
QH10		4822 130 63929	CHIP 2SC3324	HX333241B0
QN01		4822 130 61355	2SC2712 0,Y	HX327122A0
QN02		4822 130 61355	2SC2712 0,Y	HX327122A0
QN03		4822 130 61355	2SC2712 0,Y	HX327122A0
QN04		4822 130 61311	2SA1162 0,Y	HX111622A0
QN51				
∫		4822 130 43818	2SC2878 A/B	HT328782A0
QN54				

(VERS.:VERSION, U:U.S.A., F:JAPAN, K:FAR EAST, **:EUROPE)

POS. NO	VERS. COLOR	PART NO. (FOR PCS)	DESCRIPTION	PART NO. (MJI)
QT01		4822 209 32442	TC7WU04F	HC000305K0
▲QY61		4822 209 83828	NJM79M15FA	HC39515090
Q301		4822 209 33578	TDA1315	HC10117490
Q311		4822 209 32442	TC7WU04F	HC000305K0
Q510		9965 000 00601	PMD-100 HDCD DECO.& DIGI.FIL.	HC10058990
Q511		4822 209 31423	TC7W04F	HC700405W0
Q512		4822 209 61494	74HC74A	HC707400Z0
Q513		4822 130 61355	2SC2712 O,Y	HX327122A0
Q516		4822 130 61311	2SA1162 Q,Y	HX111622A0
Q520		4822 209 31356	SAA7350	HC10096490
Q601		4822 209 91175	NJM2114M	HC10175090
Q602		4822 209 91175	NJM2114M	HC10175090
Q631		4822 130 43818	2SC2878 A/B	HT328782A0
Q632		4822 130 43818	2SC2878 A/B	HT328782A0
Q641		4822 130 61311	CHIP 2SA1162	HX111622A0
Q642		4822 130 61355	CHIP 2SC2712 O,Y	HX327122A0
Q651		5322 130 41844	FET 2SK170 V	HF201701H0
Q652		5322 130 41844	FET 2SK170 V	HF201701H0
Q653		4822 130 62649	FET 2SJ74 V	HF100741H0
Q654		4822 130 62649	FET 2SJ74 V	HF100741H0
▲Q801		4822 209 17381	PQ05RD21 5V 2A	HC31905320
▲Q803		4822 209 80655	NJM78M08FA +8V 0.5A	HC38508090
▲Q811		4822 209 17436	BA05T 5V/1A	HC36905210
▲Q821		4822 209 62943	NJM79M08FA	HC39508090
▲Q822		4822 209 82828	NJM78M12FA	HC38512090
▲Q831		4822 130 62704	2SB1225(PNP)	HT212251A0
▲Q832		5322 130 41842	2SD1827(NPN)	HT418271A0
▲Q851		4822 130 62704	2SB1225(PNP)	HT212251A0
▲Q852		5322 130 41842	2SD1827(NPN)	HT418271A0
RESISTORS CHIP				
RD01				
∫		4822 117 10145	3.3 Ω 1/10W J	NH85033110
RD04				
RD05		4822 116 83253	1.5k Ω 1/10W F	NI01152110
RD06		4822 116 83253	1.5k Ω 1/10W F	NI01152110
RD07		4822 116 83255	3.3k Ω 1/10W F	NI01332110
RD08		4822 116 83255	3.3k Ω 1/10W F	NI01332110
RD09		4822 117 11953	560 Ω 1/10W J	NI05561110
RD10		4822 117 11953	560 Ω 1/10W J	NI05561110
RD11		4822 117 10837	100k Ω 1/10W F	NI01104110
RD12		4822 117 10837	100k Ω 1/10W F	NI01104110
RD13				
∫		4822 117 11976	13k Ω 1/10W F	NI01133110
RD16				
RD21		4822 117 10145	3.3 Ω 1/10W J	NH85033110
RD22		4822 117 10145	3.3 Ω 1/10W J	NH85033110
RD25		4822 117 10145	3.3 Ω 1/10W J	NH85033110
RF01		4822 051 30103	10k Ω 1/16W J	NN05103610
RF02		4822 051 30681	680 Ω 1/16W J	NN05681610
RF03		4822 051 30472	4.7k Ω 1/16W J	NN05472610
RF04				
∫		4822 051 30103	10k Ω 1/16W J	NN05103610
RF07				
RF08		4822 051 30472	4.7k Ω 1/16W J	NN05472610
RF09		4822 051 30101	100 Ω 1/16W J	NN05101610
RF10		4822 117 12925	47k Ω 1/16W J	NN05473610
RF31		4822 051 30103	10k Ω 1/16W J	NN05103610
RF32		4822 051 30103	10k Ω 1/16W J	NN05103610
RF33		4822 051 30393	39k Ω 1/16W J	NN05393610
RF51		4822 117 12139	22 Ω 1/16W J	NN05220610
RF52		4822 051 30103	10k Ω 1/16W J	NN05103610
RF53		4822 051 30222	2.2k Ω 1/16W J	NN05222610
RF54		4822 051 30103	10k Ω 1/16W J	NN05103610
RF55		4822 051 30223	22k Ω 1/16W J	NN05223610

(VERS.:VERSION, U:U.S.A., F:JAPAN, K:FAR EAST, **:EUROPE)

POS. NO	VERS. COLOR	PART NO. (FOR PCS)	DESCRIPTION	PART NO. (MJI)
RH01		4822 111 90892	0 Ω 1/10W	NI05000110
RH02		4822 111 90892	0 Ω 1/10W	NI05000110
RH03				
∫		4822 116 90503	150 Ω 1/10W J	NI05151110
RH06				
RH07		4822 111 90893	100 Ω 1/10W J	NI05101110
RH08		4822 111 90893	100 Ω 1/10W J	NI05101110
RH09		4822 117 11953	560 Ω 1/10W J	NI05561110
RH10		4822 117 11953	560 Ω 1/10W J	NI05561110
RH11				
∫		4822 111 90893	100 Ω 1/10W J	NI05101110
RH14				
RH15		4822 116 83229	33k Ω 1/10W F	NI01333110
RH16		4822 116 83229	33k Ω 1/10W F	NI01333110
RH17		4822 117 11953	560 Ω 1/10W J	NI05561110
RH18		4822 117 11953	560 Ω 1/10W J	NI05561110
RH19		4822 111 90893	100 Ω 1/10W J	NI05101110
RH20		4822 111 90893	100 Ω 1/10W J	NI05101110
RN01		4822 051 30472	4.7k Ω 1/16W J	NN05472610
RN02		4822 117 13632	100k Ω 1/16W J	NN05104610
RN03		4822 117 12925	47k Ω 1/16W J	NN05473610
RN04		4822 051 30154	150k Ω 1/16W J	NN05154610
RN05		4822 051 30392	3.9k Ω 1/16W J	NN05392610
RN06		4822 051 30103	10k Ω 1/16W J	NN05103610
RN07		4822 117 13632	100k Ω 1/16W J	NN05104610
RN51				
∫		4822 051 30222	2.2k Ω 1/16W J	NN05222610
RN54				
RT01		4822 157 10416	BLM11B/02S FERRITE BEADS	FN31010030
RT02		4822 051 30759	75 Ω 1/16W J	NN05750610
RT03		4822 051 30101	100 Ω 1/16W J	NN05101610
RT04		4822 157 10416	BLM11B/02S FERRITE BEADS	FN31010030
RT05		4822 157 10416	BLM11B/02S FERRITE BEADS	FN31010030
▲RY62		4822 053 10151	150 Ω 1W J NON CHIP	GA05151010
R301		4822 051 30101	100 Ω 1/16W J	NN05101610
R311		4822 051 30759	75 Ω 1/16W J	NN05750610
R312		4822 051 30332	3.3k Ω 1/16W J	NN05332610
R313		4822 051 30332	3.3k Ω 1/16W J	NN05332610
R314		4822 051 30101	100 Ω 1/16W J	NN05101610
R501		4822 051 30471	470 Ω 1/16W J	NN05471610
R502		4822 157 10416	BLM11B/02S FERRITE BEADS	FN31010030
R503		4822 157 10416	BLM11B/02S FERRITE BEADS	FN31010030
R504		4822 157 10416	BLM11B/02S FERRITE BEADS	FN31010030
R507		4822 051 30223	22k Ω 1/16W J	NN05223610
R509		4822 157 10416	BLM11B/02S FERRITE BEADS	FN31010030
R510		4822 051 30223	22k Ω 1/16W J	NN05223610
R511		4822 051 30223	22k Ω 1/16W J	NN05223610
R512		4822 051 30223	22k Ω 1/16W J	NN05223610
R513				
∫		4822 157 10416	BLM11B/02S FERRITE BEADS	FN31010030
R516				
R520		4822 051 30105	1M Ω 1/16W J	NN05105610
R521		4822 157 10416	BLM11B/02S FERRITE BEADS	FN31010030
R522		4822 157 10416	BLM11B/02S FERRITE BEADS	FN31010030
R523		4822 157 10416	BLM11B/02S FERRITE BEADS	FN31010030
R526		4822 117 13632	100k Ω 1/16W J	NN05104610
R527		4822 157 10416	BLM11B/02S FERRITE BEADS	FN31010030
R528		4822 157 10416	BLM11B/02S FERRITE BEADS	FN31010030
R529		4822 051 30103	10k Ω 1/16W J	NN05103610
R601			10k Ω 1/4W F	GM11410020
R602			10k Ω 1/4W F	GM11410020
R603		4822 117 11981	3.3k Ω 1/2W J	RI05332120
R604		4822 117 11981	3.3k Ω 1/2W J	RI05332120
R605		9965 000 00595	6.49k Ω 1/4W F	GM11464910
R606		9965 000 00595	6.49k Ω 1/4W F	GM11464910
R607		9965 000 00596	22.6k Ω 1/4 F	GM11422620

(VERS.:VERSION, U:U.S.A., F:JAPAN, K:FAR EAST, **:EUROPE)

POS. NO	VERS. COLOR	PART NO. (FOR PCS)	DESCRIPTION	PART NO. (MJI)
R608		9965 000 00596	22.6k Ω 1/4W F	GM11422620
R611		4822 116 83227	1k Ω 1/10WF	NI01102110
R612		4822 116 83227	1k Ω 1/10WF	NI01102110
R613		4822 116 83253	1.5k Ω 1/10WF	NI01152110
R614		4822 116 83253	1.5k Ω 1/10WF	NI01152110
R615		9965 000 00597	2.61k Ω 1/10W F	NI01262110
R616		9965 000 00597	2.61k Ω 1/10W F	NI01262110
R617				
}		4822 117 10145	3.3 Ω 1/10W J	NH85033110
R620				
R621		4822 111 90896	100k Ω 1/10W J	NI05104110
R622		4822 111 90896	100k Ω 1/10W J	NI05104110
R631		4822 111 91365	470 Ω 1/10W F	NI01471110
R632		4822 111 91365	470 Ω 1/10W F	NI01471110
R633		4822 051 30223	22k Ω 1/16W J	NN05223610
R634		4822 051 30223	22k Ω 1/16W J	NN05223610
R641		4822 051 30223	22k Ω 1/16W J	NN05223610
R642		4822 117 13632	100k Ω 1/16W J	NN05104610
R643		4822 051 30223	22k Ω 1/16W J	NN05223610
R644		4822 051 30223	22k Ω 1/16W J	NN05223610
R651				
}		4822 116 60309	2.2 Ω 1/4W J	NH05022140
R654				
R655				
}			33 Ω 1/6W J NON CHIP	GG05330160
R658				
R659		4822 117 10833	10k Ω 1/10W J	NI05103110
R660		4822 117 10833	10k Ω 1/10W J	NI05103110
R661				
}		4822 111 90893	100 Ω 1/10W J	NI05101110
R664				
R665		4822 111 90896	100k Ω 1/10W J	NI05104110
R666		4822 111 90896	100k Ω 1/10W J	NI05104110
R801		4822 051 30223	22k Ω 1/16W J	NN05223610
R835		4822 111 90967	4.7 Ω 1/4W J	NF05047140
R836		4822 111 90967	4.7 Ω 1/4W J	NF05047140
			MISCELLANEOUS	
JF51		4822 267 41009	RCA PIN JACK 2P	YT02020890
JF52		9965 000 00607	HLW16S-2C7 1MM PITCH FFC CONE.	YJ07012760
JT01		4822 265 11582	1P RCA PIN JACK	YT02011000
JT02		4822 267 31369	GP1F32T OPTICAL OUTPUT	YJ15000090
JT03		9965 000 00607	HLW16S-2C7 1MM PITCH FFC CONE.	YJ07012760
J301		4822 218 11487	GP1F32R OPTICAL RECIVER	YJ15000150
J311		4822 265 11582	RCA PIN JACK 1P	YT02011000
J651		9965 000 00593	RCA PIN JACK 2P (T6743 BLK/BLK)	YT02021390
LF01		4822 158 60654	FERRITE BEADS	FC90030070
LT01		4822 158 60654	FERRITE BEADS	FC90030070
LT02		4822 158 60654	FERRITE BEADS	FC90030070
LT04		4822 142 60422	PULSE TRANSF. (TPS247MN-0386AN)	TP41042030
L301		4822 158 60654	FERRITE BEADS	FC90030070
L303		4822 158 60654	FERRITE BEADS	FC90030070
L311		4822 158 60654	FERRITE BEADS	FC90030070
L601		4822 157 53873	CHIP INDUCTER 100UH	LU12104010
L602		4822 157 53873	CHIP INDUCTER 100UH	LU12104010
L651	FN	4822 158 60654	BLM31A02 CHIP INDUCTOR	FC90030070
L651	U1BU1G	4822 158 60654	BLM31A02 CHIP INDUCTOR	FC90030070
L652	FN	4822 158 60654	BLM31A02 CHIP INDUCTOR	FC90030070
L652	U1BU1G	4822 158 60654	BLM31A02 CHIP INDUCTOR	FC90030070
L610				
}		4822 158 60654	BLM31A02 CHIP INDUCTOR	FC90030070
L614				

(VERS.:VERSION, U:U.S.A., F:JAPAN, K:FAR EAST, **:EUROPE)

POS. NO	VERS. COLOR	PART NO. (FOR PCS)	DESCRIPTION	PART NO. (MJI)
L901		4822 158 60654	FERRITE BEADS	FC90030070
L902		4822 158 60654	FERRITE BEADS	FC90030070
SF01		4822 277 21559	SLIDE SW. INT/EXT	SS02021150
XF01		9965 000 00608	432kHz (CSB432EB)	FQ04323010
			PY16-LLM CIRCUIT BOARD CAPACITORS	
CY01		9965 000 00603	ELECT 47 μ F 10V	EG47601050
CY02		4822 126 13837	CER. 0.1 μ F K CHIP	DK96104200
CY03		4822 122 40617	CER. 0.1 μ F 50V Z	DD38104010
CY04		4822 122 33761	CER. 22pF 50V J CHIP	DD95220300
CY05		4822 122 33761	CER. 22pF 50V J CHIP	DD95220300
CY06		4822 126 13837	CER. 0.1 μ F K CHIP	DK96104200
CY07		4822 122 33761	CER. 22pF 50V J CHIP	DD95220300
CY08		4822 122 33761	CER. 22pF 50V J CHIP	DD95220300
CY09		4822 126 13837	CER. 0.1 μ F K CHIP	DK96104200
CY10		4822 126 13837	CER. 0.1 μ F K CHIP	DK96104200
CY11		4822 126 13837	CER. 0.1 μ F K CHIP	DK96104200
CY12		9965 000 00603	ELECT 47 μ F 10V	EG47601050
CY13		4822 126 13883	CER. 220pF 50V J CHIP	DD95221300
			DIODES	
DY01		4822 130 80326	LT3D8B RED 30	HI10062320
DY02		4822 130 80326	LT3D8B RED 30	HI10062320
DY03		4822 130 81324	CHIP 1SS302	HZ20018050
DY04		4822 130 81324	CHIP 1SS302	HZ20018050
			TRANSISTORS	
QY01		4822 209 16055	TMP87CH74F MICROPROCESSOR	HU376KT000
QY02		4822 209 90908	TC4W53FU	HC10399050
QY03		4822 130 61355	2SC2712 0,Y	HX327122A0
QY04			TC74HC74AF	HC707405Z0
			RESISTORS	
RY01		4822 051 30393	39K Ω 1/16W J	NN05393610
RY02		4822 116 82487	0 Ω 1/16W	NN05000610
RY03		4822 116 82487	0 Ω 1/16W	NN05000610
RY04		4822 051 30101	100 Ω 1/16W J	NN05101610
RY05		4822 051 30101	100 Ω 1/16W J	NN05101610
RY06		4822 051 30102	1k Ω 1/16W J	NN05102610
RY07		4822 051 30102	1k Ω 1/16W J	NN05102610
RY08				
}		4822 051 30472	4.7k Ω 1/16W J	NN05472610
RY15				
RY16		4822 051 30471	470 Ω 1/16W J	NN05471610
RY17		4822 051 30103	10k Ω 1/16W J	NN05103610
RY18		4822 051 30471	470 Ω 1/16W J	NN05471610
RY20		4822 117 13632	100k Ω 1/16W J	NN05104610
RY21		4822 051 30103	10k Ω 1/16W J	NN05103610
RY23		4822 17 13632	100k Ω 1/16W J	NN05104610
RY24		4822 051 30103	10k Ω 1/16W J	NN05103610
RY25		4822 051 30101	100 Ω 1/16W J	NN05101610
RY26		4822 051 30101	100 Ω 1/16W J	NN05101610
RY27		4822 051 30101	100 Ω 1/16W J	NN05101610
			MISCELLANEOUS	
JY01		9965 000 00604	HLW16R-2C7 1MM PITCH FFC ANGLE	YJ07013060
SY01				
}		9965 000 00373	TACT SW.	SP01013370
SY13				
VY01		4822 135 00149	BJ563GK FTD	HQ30706410
XY01		4822 242 80349	CERALOCK EFOV8004B0 8MHz	FQ08004030
ZY01		4822 130 11494	PRM6936-V4(IR SENSER)	HW10004210

(VERS.:VERSION, U:U.S.A., F:JAPAN, K:FAR EAST, **:EUROPE)

POS. NO	VERS. COLOR	PART NO. (FOR PCS)	DESCRIPTION	PART NO. (MJI)
P716-LA1 CIRCUIT BOARD CAPACITORS				
C711		4822 122 31765	CER. 100pF 50V J CHIP	DD95101300
C712		4822 122 31765	CER. 100pF 50V J CHIP	DD95101300
C713		4822 124 22698	ELECT 47 μ F 25V M	OA47602520
C714		4822 124 22698	ELECT 47 μ F 25V M	OA47602520
C715		5322 126 11578	CER. 1000pF 50V K CHIP	DK96102300
C716		5322 126 11578	CER. 1000pF 50V K CHIP	DK96102300
C951		4822 122 40617	CER. 0.1 μ F 50V Z	DD38104010
RESISTORS				
R711		4822 117 13632	100k Ω 1/16W J	NN05104610
R712		4822 117 13632	100k Ω 1/16W J	NN05104610
R713		4822 117 13632	100k Ω 1/16W J	NN05104610
R714		4822 117 13632	100k Ω 1/16W J	NN05104610
R715				
∫		4822 116 82487	0 Ω 1/6W	NN05000610
R718				
R723		4822 116 82487	0 Ω 1/6W	NN05000610
R724		4822 116 82487	0 Ω 1/6W	NN05000610
MISCELLANEOUS				
J701		9965 000 00593	RCA PIN JACK 2P T6743 BLK	YT02021390
L701		4822 158 60654	FERRITE BEADS	FC90030070
L702		4822 158 60654	FERRITE BEADS	FC90030070
P726-LA1 CIRCUIT BOARD CAPACITORS				
C721		4822 124 41535	ELECT 100 μ F 25V	OA10702520
C722		4822 124 41535	ELECT 100 μ F 25V	OA10702520
C723		4822 126 11687	CER. 0.1 μ F Z CHIP	DK98104200
C724		4822 126 11687	CER. 0.1 μ F Z CHIP	DK98104200
C731		4822 124 41539	ELECT 47 μ F 16V M	OA47601620
C732		4822 124 41539	ELECT 47 μ F 16V M	OA47601620
C954		4822 122 40617	CER. 0.1 μ F 50V Z	DD38104010
C955		4822 122 40617	CER. 0.1 μ F 50V Z	DD38104010
C956		4822 122 40617	CER. 0.1 μ F 50V Z	DD38104010
TRANSISTOR				
Q721		4822 209 91175	FLATPACK NJM2114M	HC10175090
RESISTORS				
R721		9965 000 00594	RK18112 20K 18KAKU REC.VOL.	RM02030550
R731				
∫		4822 051 30103	10k Ω 1/16W J	NN05103610
R734				
P816-LPS CIRCUIT BOARD DIODES				
D891		4822 130 82421	1D3 1A/200V	HD20002710
D893		4822 130 82421	1D3 1A/200V	HD20002710
P916-LHP CIRCUIT BOARD CAPACITORS				
C901		4822 124 12404	ELECT 220 μ F 16V M	OA22701620
C902		4822 126 11687	CER. 0.1 μ F Z CHIP	DK98104200
C903		4822 124 12404	ELECT 220 μ F 16V M	OA22701620
C904		4822 126 11687	CER. 0.1 μ F Z	DK98104200
C911		4822 126 12339	CER. 2200pF K	DK96222300
C912		4822 126 12339	CER. 2200pF K	DK96222300
C913		4822 124 41535	ELECT 100 μ F 25V	OA10702520
C914		4822 124 41535	ELECT 100 μ F 25V	OA10702520
TRANSISTORS				
QN91		4822 130 63844	DIGITAL HN1C03F	BA20016050
QN92		4822 130 63844	DIGITAL HN1C03F	BA20016050
Q901		4822 209 31378	NJM-4556MB	HC10045090

(VERS.:VERSION, U:U.S.A., F:JAPAN, K:FAR EAST, **:EUROPE)

POS. NO	VERS. COLOR	PART NO. (FOR PCS)	DESCRIPTION	PART NO. (MJI)
RESISTORS				
RN91				
∫		4822 051 30222	2.2k Ω 1/16W J	NN05222610
RN94				
R901		4822 051 30123	12k Ω 1/16W J	NN05123610
R902		4822 051 30123	12k Ω 1/16W J	NN05123610
R903		4822 051 30273	27k Ω 1/16W J	NN05273610
R904		4822 051 30273	27k Ω 1/16W J	NN05273610
R905				
∫		4822 051 30759	75 Ω 1/16W J	NN05750610
R908				
R910		9965 000 00602	RK09L12B0 10KB H.P. VOL.	RM01031170
R911		4822 117 13632	100k Ω 1/16W J	NN05104610
R912		4822 117 13632	100k Ω 1/16W J	NN05104610
MISCELLANEOUS				
J902	FN	4822 267 31692	H.P. JACK HLJ0540-01-430 GRY	YJ01003880
J902	N1B U1B	4822 267 31692	H.P. JACK HLJ0540-01-410 BLK	YJ01003870
J902	N1G U1G	4822 267 31692	H.P. JACK HLJ0540-01-430 GRY	YJ01003880
L910			USB-4 WITH W901	FC50270040
L815			USB-4 WITH W815	FC50270040
LH01			TFCK-25-15- FERRITE CORD	FC50250020

Service Manual

CDRL3610 /01

CDR Module

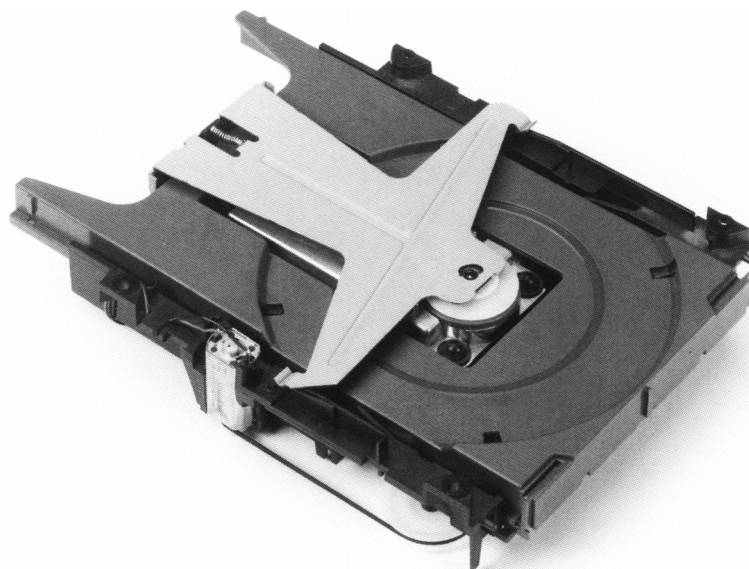

CAUTION : This part is instruction for Central repair center only.

Do not repair at local Service agent.

Please contact to MARANTZ JAPAN INC., MARANTZ EUROPE B.V.,
MARANTZ AMERICA,INC.

FOR Central repair procedure.

TABLE OF CONTENTS

SECTION	PAGE
2.1 BLOCK DIAGRAM MAIN BOARD	2-1
2.2 PARTS LOCATION	2-3
2.3 EXPLODED VIEW AND PARTS LIST	2-7

marantz®

model CDRL3610

[REMARK]

CDRL3610/10 unit (CDR Module) and CDM3610' are not standard spare parts. The repairing of component level for those units is not allowed at local service agents also, except loader mechanical parts.

Rejected CDRL3610/10 unit (CDR Module) should replace by Central Repair Procedure. Please contact to following MARANTZ regional office or your local MARANTZ national organization about the Central Repair Procedure.

USA

MARANTZ AMERICA, INC.
440 MEDINAH ROAD
ROSELLE, ILLINOIS 60172
USA
PHONE : 630 - 307 - 3100
FAX : 630 - 307 - 2687

EUROPE / TRADING

MARANTZ EUROPE B. V.
P.O.BOX 80002
BUILDING SFF2
5600 JB EINDHOVEN
THE NETHERLANDS
PHONE : +31 - 40 - 2732241
FAX : +31 - 40 - 2735578

JAPAN *Technical*

MARANTZ JAPAN, INC.
35- 1, 7- CHOME, SAGAMIONO
SAGAMIHARA - SHI, KANAGAWA
JAPAN 228-8505
PHONE : +81 427 48 9379
FAX : +81 427 48 0889

EPROM (7322)

This USER SOFTWARE has been stored in EPORM (7322). This EPROM, situated on the upper side of the Main Board of the CDR module, is in easy reach, once the tray is open. On the EPROM, you will find a sticker with the following indications :

MAIN DR-17
V.1.xx
7322

DR-17

V.1.xx is the software version.

As this IC is mounted on a socket, it can easily be replaced an EPROM containing the last software version. This EPROM can be ordered with service code number ;

DR-17 : 4822 900 11335

The latest software update information will be reported by the **SERVICE BULLETIN**.

(latest version EPROM will be supplied with same service code number always)

2.1 BLOCK DIAGRAM MAIN BOARD

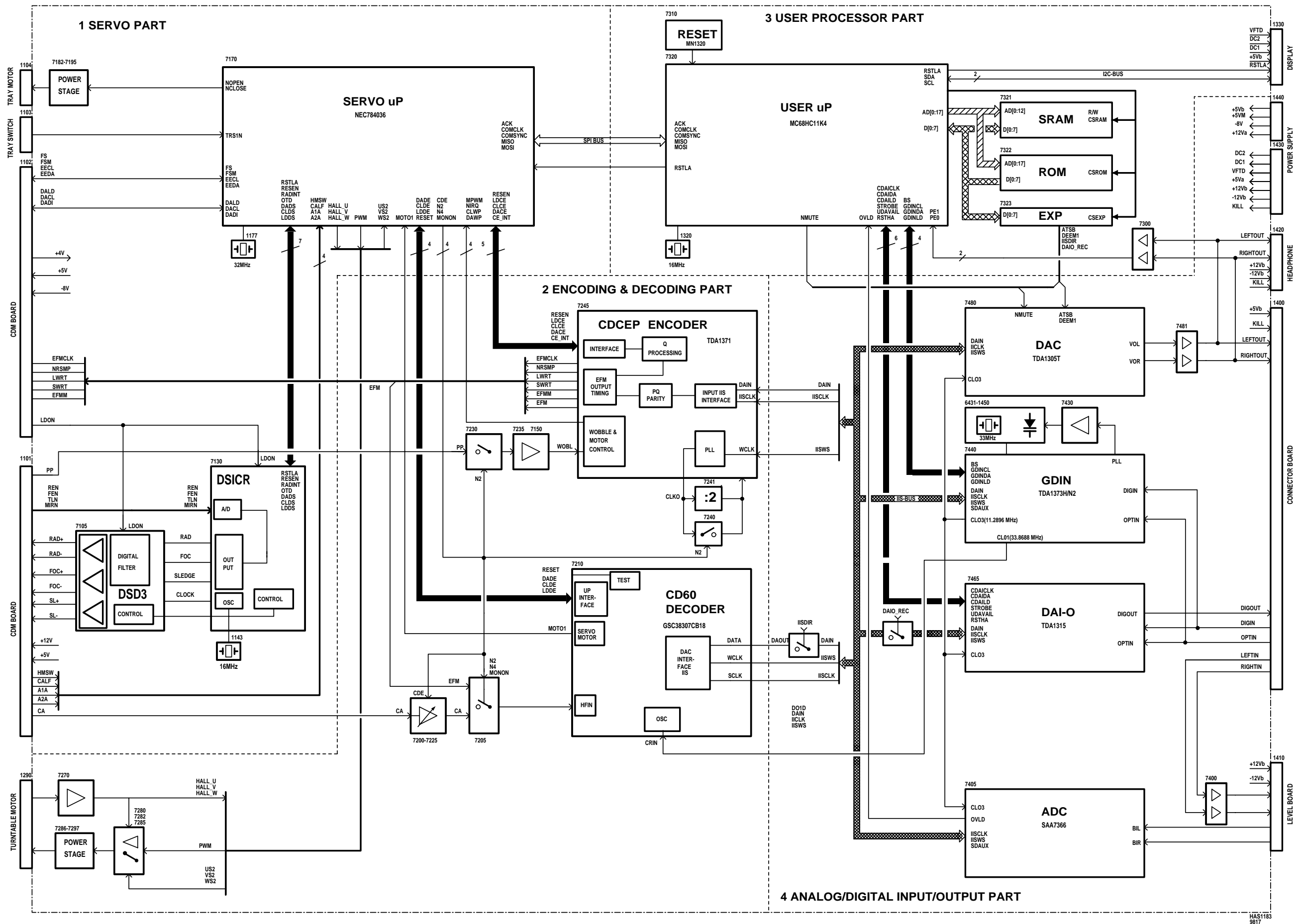

2.2 PARTS LOCATION (MAIN BOARD)

COMPONENT SIDE

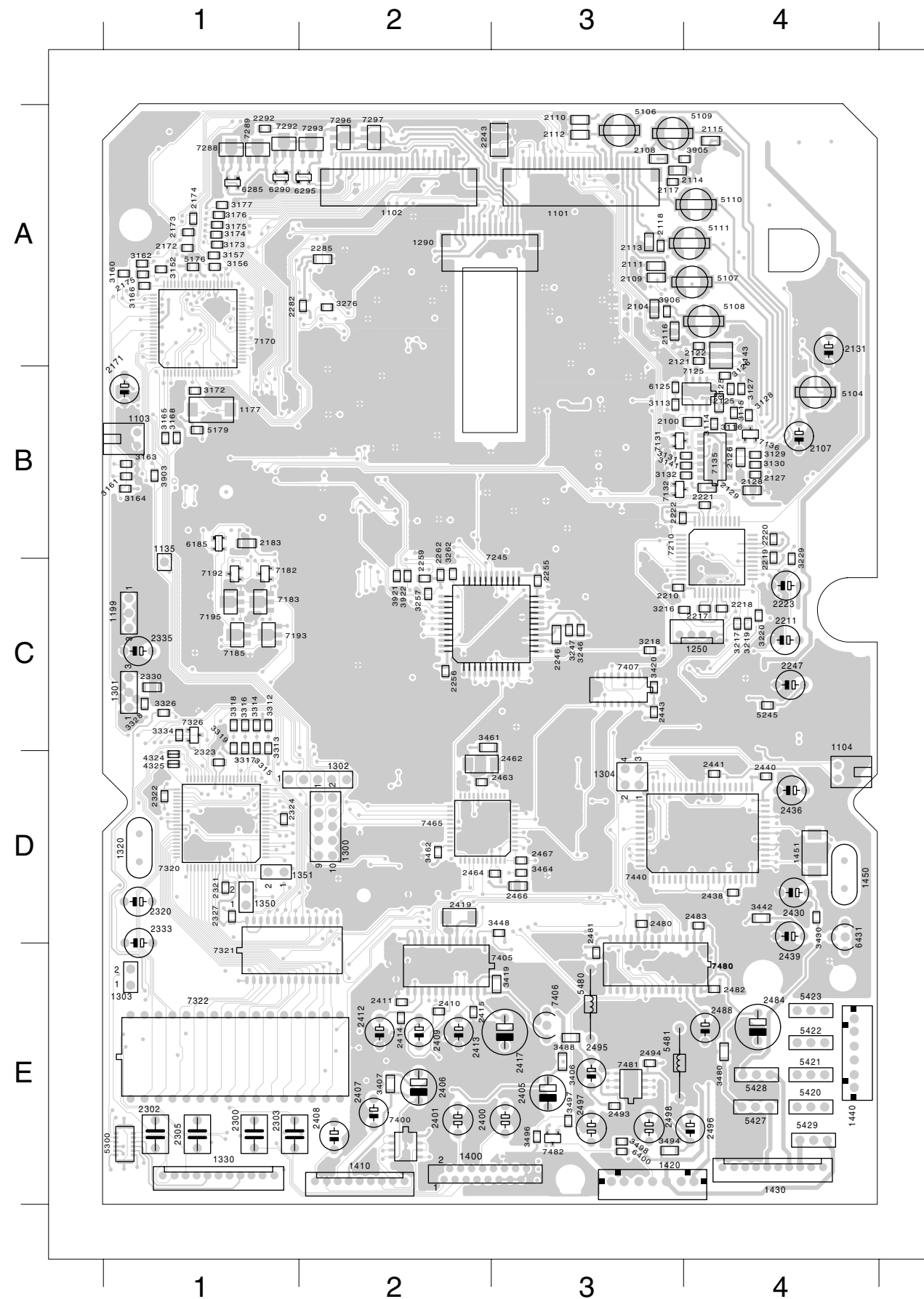

1101 A 3	2409 E 2	3461 C 2
1102 A 2	2410 E 2	3462 D 2
1103 B 1	2411 E 2	3464 D 3
1104 D 4	2412 E 2	3480 E 4
1135 C 1	2413 E 2	3488 E 3
1143 A 4	2414 E 2	3494 E 3
1177 B 1	2415 E 2	3496 E 3
1199 C 1	2417 E 3	3497 E 3
1250 C 4	2419 D 2	3498 E 3
1290 A 2	2430 D 4	3903 B 1
1300 D 2	2436 D 4	3905 A 4
1301 C 1	2438 D 4	3906 A 3
1302 D 1	2439 D 4	3921 C 2
1303 E 1	2440 D 4	3922 C 2
1304 D 3	2441 D 4	4324 D 1
1320 D 1	2443 C 3	4325 D 1
1330 E 1	2462 D 2	5104 B 4
1350 D 1	2463 D 2	5106 A 3
1351 D 1	2464 D 3	5107 A 4
1400 E 2	2466 D 3	5108 A 4
1410 E 2	2467 D 3	5109 A 3
1420 E 3	2480 D 3	5110 A 4
1430 E 4	2481 E 3	5111 A 4
1440 E 4	2482 E 4	5176 A 1
1450 D 4	2483 D 4	5179 B 1
1451 D 4	2484 E 4	5245 C 4
2100 B 4	2488 E 4	5300 E 1
2104 A 3	2493 E 3	5420 E 4
2107 B 4	2494 E 3	5421 E 4
2108 A 3	2495 E 3	5422 E 4
2109 A 3	2496 E 4	5423 E 4
2110 A 3	2497 E 3	5427 E 4
2111 A 3	2498 E 3	5428 E 4
2112 A 3	3113 B 3	5429 E 4
2113 A 3	3114 B 4	5480 E 3
2114 A 3	3115 B 4	5481 E 3
2115 A 4	3116 B 4	6125 B 3
2116 A 3	3125 B 4	6185 B 1
2117 A 3	3126 B 4	6285 A 1
2118 A 3	3127 B 4	6290 A 1
2121 A 4	3128 B 4	6295 A 2
2122 A 4	3129 B 4	6400 E 3
2125 B 4	3130 B 4	6431 D 4
2126 B 4	3131 B 4	7125 B 4
2127 B 4	3132 B 4	7131 B 3
2128 B 4	3141 B 4	7132 B 3
2129 B 4	3152 A 1	7135 B 4
2131 A 4	3156 A 1	7136 B 4
2171 B 1	3157 A 1	7170 A 1
2172 A 1	3160 A 1	7182 C 1
2173 A 1	3161 B 1	7183 C 1
2174 A 1	3162 A 1	7185 C 1
2175 A 1	3163 B 1	7192 C 1
2183 B 1	3164 B 1	7193 C 1
2210 C 3	3165 B 1	7195 C 1
2211 C 4	3166 A 1	7210 B 4
2217 C 4	3168 B 1	7245 C 3
2218 C 4	3172 B 1	7288 A 1
2219 B 4	3173 A 1	7289 A 1
2220 B 4	3174 A 1	7292 A 1
2221 B 4	3175 A 1	7293 A 2
2222 B 3	3176 A 1	7296 A 2
2223 C 4	3177 A 1	7297 A 2
2243 A 3	3216 C 4	7320 D 1
2246 C 3	3217 C 4	7321 E 1
2247 C 4	3218 C 3	7322 E 1
2255 C 3	3219 C 4	7326 C 1
2256 C 2	3220 C 4	7400 E 2
2259 C 2	3229 C 4	7405 E 2
2262 C 2	3246 C 3	7406 E 3
2282 A 2	3247 C 3	7407 C 3
2285 A 2	3257 C 2	7440 D 4
2292 A 1	3262 C 2	7465 D 2
2300 E 1	3276 A 2	7480 E 3
2302 E 1	3312 C 1	7481 E 3
2303 E 1	3313 C 1	7482 E 3
2305 E 1	3314 C 1	
2320 D 1	3315 C 1	
2321 D 1	3316 C 1	
2322 D 1	3317 C 1	
2323 D 1	3318 C 1	
2324 D 1	3319 C 1	
2327 D 1	3326 C 1	
2330 C 1	3328 C 1	
2333 E 1	3334 C 1	
2335 C 1	3406 E 3	
2400 E 3	3407 E 2	
2401 E 2	3419 E 3	
2405 E 3	3420 C 3	
2406 E 2	3430 D 4	
2407 E 2	3442 D 4	
2408 E 2	3448 D 3	

MAIN BOARD

SOLDER SIDE

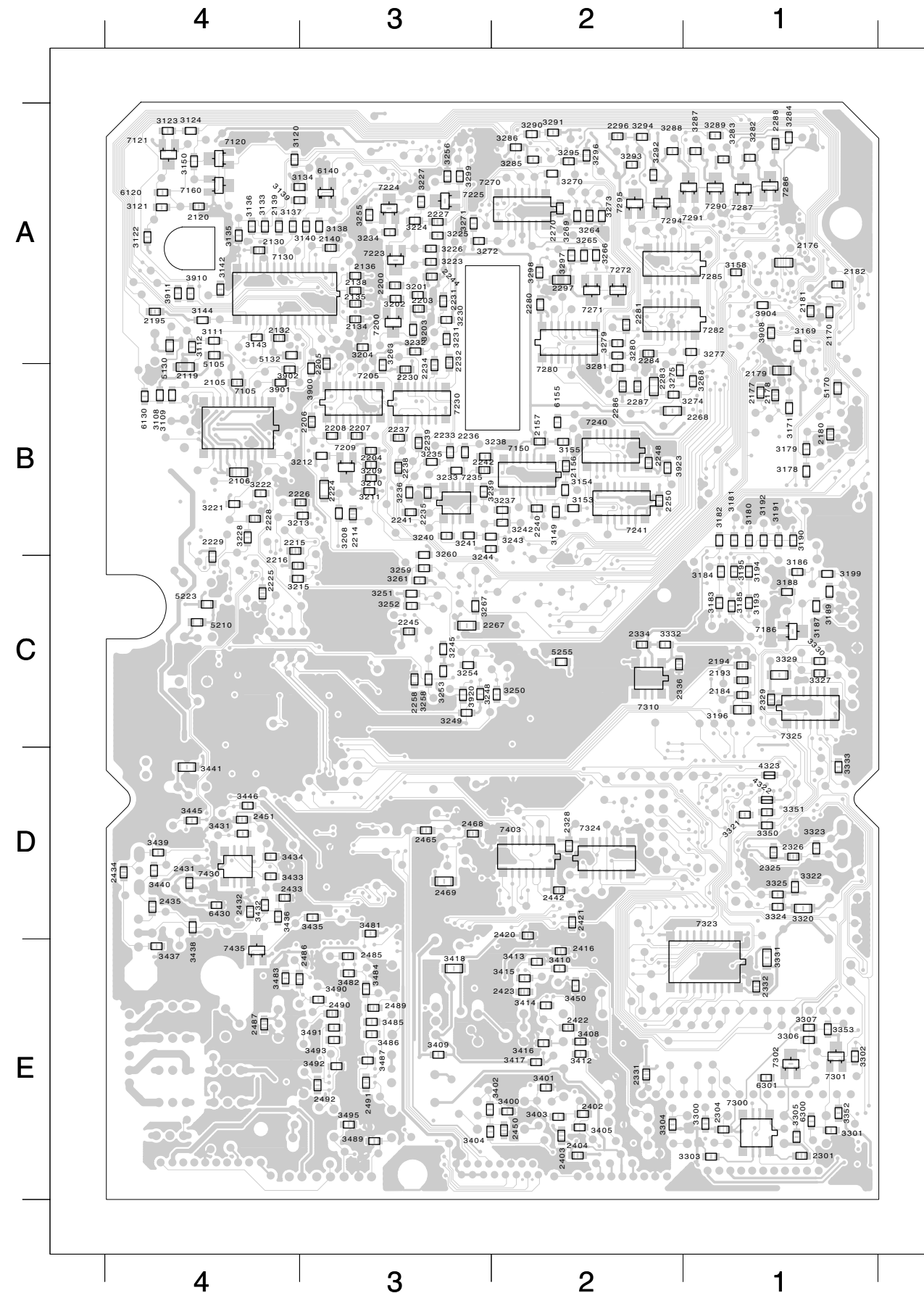

2105 B 4	2433 D 4	3239 B 3	3416 E 2	7430 D 4
2106 B 4	2434 D 4	3240 B 3	3417 E 2	7435 E 4
2119 B 4	2435 D 4	3241 B 3	3418 E 3	
2120 A 4	2442 D 2	3242 B 2	3431 D 4	
2130 A 4	2450 E 2	3243 B 3	3432 D 4	
2132 A 4	2451 D 4	3244 B 3	3433 D 4	
2134 A 3	2465 D 3	3245 C 3	3434 D 4	
2135 A 3	2468 D 3	3248 C 3	3435 D 3	
2136 A 3	2469 D 3	3249 C 3	3436 D 4	
2138 A 3	2485 E 3	3250 C 2	3437 E 4	
2139 A 4	2486 E 4	3251 C 3	3438 D 4	
2140 A 3	2487 E 4	3252 C 3	3439 D 4	
2156 B 2	2489 E 3	3253 C 3	3440 D 4	
2157 B 2	2490 E 3	3254 C 3	3441 D 4	
2170 A 1	2491 E 3	3255 A 3	3445 D 4	
2176 A 1	2492 E 3	3256 A 3	3446 D 4	
2177 B 1	3108 B 4	3258 C 3	3450 E 2	
2178 B 1	3109 B 4	3259 C 3	3481 D 3	
2179 B 1	3111 A 4	3260 B 3	3482 E 3	
2180 B 1	3112 A 4	3261 C 3	3483 E 4	
2181 A 1	3120 A 4	3263 B 3	3484 E 3	
2182 A 1	3121 A 4	3264 A 2	3485 E 3	
2184 C 1	3122 A 4	3265 A 2	3486 E 3	
2193 C 1	3123 A 4	3266 A 2	3487 E 3	
2194 C 1	3124 A 4	3267 C 3	3489 E 3	
2195 A 4	3133 A 4	3268 B 1	3490 E 3	
2200 A 3	3134 A 4	3269 A 2	3491 E 3	
2203 A 3	3135 A 4	3270 A 2	3492 E 3	
2204 B 3	3136 A 4	3271 A 3	3493 E 3	
2205 B 3	3137 A 4	3272 A 3	3495 E 3	
2206 B 3	3138 A 3	3273 A 2	3900 B 3	
2207 B 3	3139 A 4	3274 B 2	3901 B 4	
2208 B 3	3140 A 3	3275 B 2	3902 B 4	
2214 B 3	3142 A 4	3277 A 1	3904 A 1	
2215 B 4	3143 A 4	3279 A 2	3908 A 1	
2216 C 4	3144 A 4	3280 A 2	3910 A 4	
2224 B 3	3149 B 2	3281 B 2	3911 A 4	
2225 C 4	3150 A 4	3282 A 1	3920 C 3	
2226 B 3	3153 B 2	3283 A 1	3923 B 2	
2227 A 3	3154 B 2	3284 A 1	4322 D 1	
2228 B 4	3155 B 2	3285 A 2	4323 D 1	
2229 C 4	3158 A 1	3286 A 2	5105 A 4	
2230 B 3	3169 A 1	3287 A 1	5130 A 4	
2231 A 3	3171 B 1	3288 A 2	5132 A 4	
2232 A 3	3178 B 1	3289 A 1	5170 B 1	
2233 B 3	3179 B 1	3290 A 2	5210 C 4	
2234 B 3	3180 B 1	3291 A 2	5223 C 4	
2235 B 3	3181 B 1	3292 A 2	5255 C 2	
2236 B 3	3182 B 1	3293 A 2	6120 A 4	
2237 B 3	3183 C 1	3294 A 2	6130 B 4	
2238 B 3	3184 C 1	3295 A 2	6140 A 3	
2239 B 3	3185 C 1	3296 A 2	6155 B 2	
2240 B 2	3186 C 1	3297 A 2	6300 E 1	
2241 B 3	3187 C 1	3298 A 2	6301 E 1	
2242 B 3	3188 C 1	3299 A 3	6430 D 4	
2244 A 3	3189 C 1	3300 E 1	7105 B 4	
2245 C 3	3190 B 1	3301 E 1	7120 A 4	
2248 B 2	3191 B 1	3302 E 1	7121 A 4	
2250 B 2	3192 B 1	3303 E 1	7130 A 4	
2258 C 3	3193 C 1	3304 E 2	7150 B 2	
2267 C 3	3194 C 1	3305 E 1	7160 A 4	
2268 B 2	3195 C 1	3306 E 1	7186 C 1	
2270 A 2	3196 C 1	3307 E 1	7200 A 3	
2280 A 2	3199 C 1	3320 D 1	7205 B 3	
2281 A 2	3201 A 3	3321 D 1	7209 B 3	
2283 B 2	3202 A 3	3322 D 1	7223 A 3	
2284 A 2	3203 A 3	3323 D 1	7224 A 3	
2286 B 2	3204 A 3	3324 D 1	7225 A 3	
2287 B 2	3208 B 3	3325 D 1	7230 B 3	
2288 A 1	3209 B 3	3327 C 1	7235 B 3	
2296 A 2	3210 B 3	3329 C 1	7240 B 2	
2297 A 2	3211 B 3	3330 C 1	7241 B 2	
2301 E 1	3212 B 3	3331 E 1	7270 A 2	
2304 E 1	3213 B 3	3332 C 2	7271 A 2	
2325 D 1	3215 C 4	3333 D 1	7272 A 2	
2326 D 1	3221 B 4	3350 D 1	7280 A 2	
2328 D 2	3222 B 4	3351 D 1	7282 A 2	
2329 C 1	3223 A 3	3352 E 1	7285 A 2	
2331 E 2	3224 A 3	3353 E 1	7286 A 1	
2332 E 1	3225 A 3	3400 E 2	7287 A 1	
2334 C 2	3226 A 3	3401 E 2	7290 A 1	
2336 C 2	3227 A 3	3402 E 3	7291 A 1	
2402 E 2	3228 B 4	3403 E 2	7294 A 2	
2403 E 2	3230 A 3	3404 E 3	7295 A 2	
2404 E 2	3231 A 3	3405 E 2	7300 E 1	
2416 E 2	3232 A 3	3408 E 2	7301 E 1	
2420 D 2	3233 B 3	3409 E 3	7302 E 1	
2421 D 2	3234 A 3	3410 E 2	7310 C 2	
2422 E 2	3235 B 3	3412 E 2	7323 E 1	
2423 E 2	3236 B 3	3413 E 2	7324 D 2	
2431 D 4	3237 B 2	3414 E 2	7325 C 1	
2432 D 4	3238 B 3	3415 E 2	7403 D 2	

2.3 EXPLODED VIEW AND PARTS LIST

POS. NO.	PART NO. (PCS)	DESCRIPTION	PART NO. (MJI)
1	4822 464 51086	CHASSIS ASSY	QP46451086
7	4822 522 10651	TRAY GEAR	QP52210651
15	4822 325 60379	DAMPING GROMMET	QP32560379
20	4822 361 21758	TRAY MOTOR ASSY	QP36121758
25	4822 276 13608	SWITCH ASSY	QP27613608
41	4822 464 51084	SUB-CHASSIS	QP46451084
46	4822 492 71688	EXTENSION	QP49271688
47	4822 325 60379	DAMPING GROMMET	QP32560379
48	4822 492 71686	CLAMPER SPRING	QP49271686
49	4822 535 93546	PULL-ROD	QP53593546
54	4822 466 11739	CLAMPER PLATE	QP46611739
55	4822 532 52676	CLAMPER	QP53252676
58	4822 492 52426	COMPRESSION SPRING	QP49252426
70	4822 418 10291	TRAY ASSY (BLACK)	QP41810291
80	4822 358 10149	BELT	QP35810149

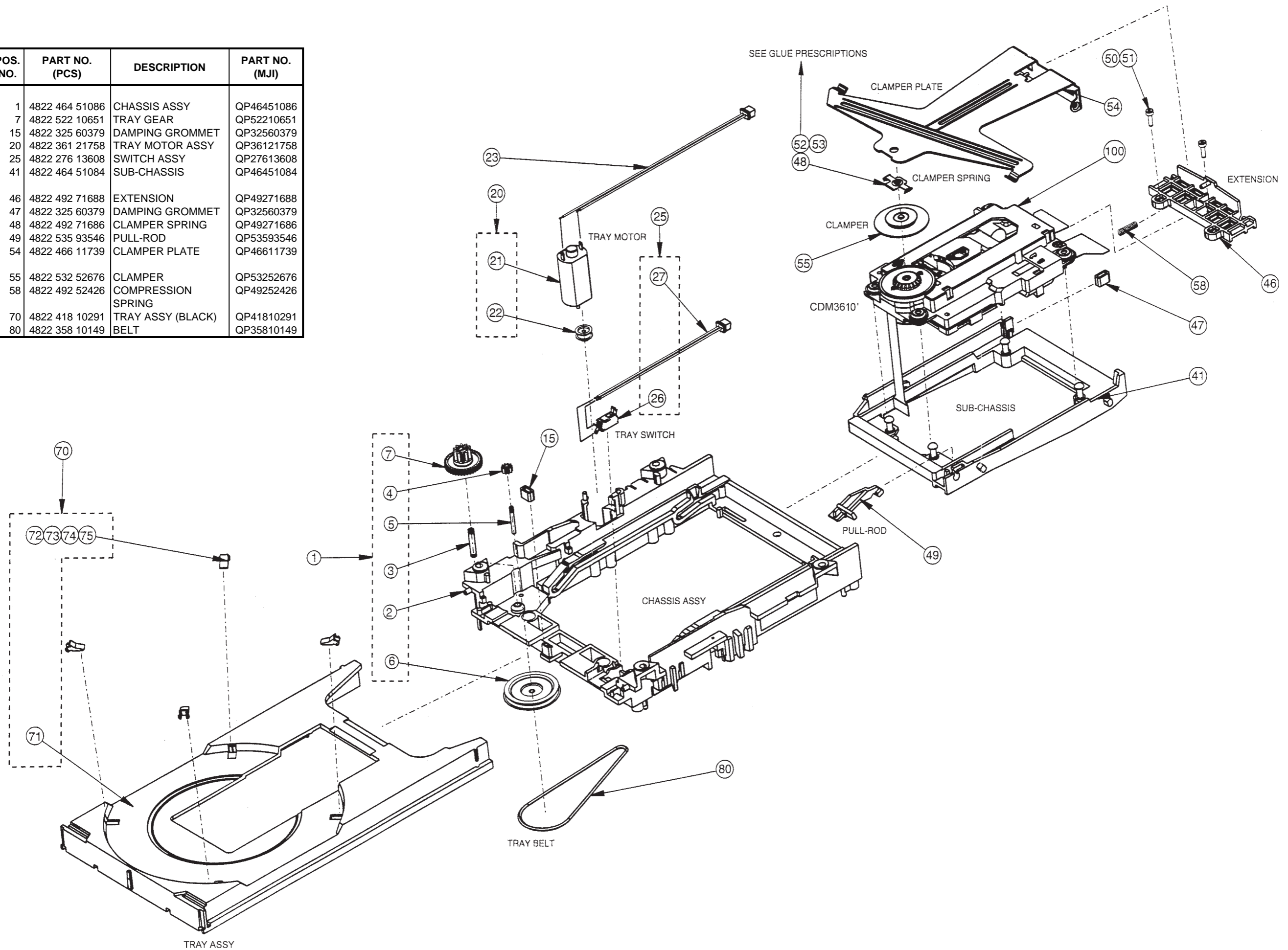

Repair Procedure

When you return the reject complete CDR loader for **Central Repair Procedure** (module exchange procedure). Please make a copy of attached sheet "**GUIDANCE FORM REPAIRABLE UNIT**" and fill in required contents. It is necessary to attach the sheet "**GUIDANCE FROM REPAIRABLE UNIT**" with each reject CDR loaders one by one.

GUIDANCE FORM REPAIRABLE UNIT 3104 129 21361

Please fill in this form and return it with the defective unit.

Typenumber (unit demounted from set) : **DR17/.....**

Serial number :

Unit serial number (CDR Module) : **CDL3610/01; ...VO.....**

warning: Dismantling of the CDR Module is not allowed. Guarantee will be invalidated. Only Returned Modules with filled in Guidance form are accepted

In case CDR-disc has been damaged, please include this damaged disc with the exchanged CDR Module

DISC DAMAGED?	Y/N
DISC INCLUDED?	Y/N

INFORMATION GATHERED VIA SERVICE TEST MODE

Switch POWER ON,
Activate OPEN/CLOSE,
Insert test disc SBC444A, or any other CD-Digital Audio disc;
switch POWER OFF,
<PLAY>+<NEXT>+<POWER ON> keep all keys pressed for 2 seconds
During test:
Blinking D on display (about 2 minutes!!);
Blinking B on display (for some seconds).

ERROR INDICATION (on display) according to table below: Y / N

	ON DISPLAY	IRIS SYMPTOM CODE	YES *)
DISPLAY TEST RESULT			
RAM error	DERR 1	15....	
ROM error	DERR 2	16....	
EEPROM error	DERR 3	16....	
DAIO error	DERR 4	15....	
GDIN error	DERR 5	15....	
BASIC ENGINE TEST RESULT			
Communication bus error	BERR 1	15....	
Basic Engine error	BERR 2	15....	
Disc test error	BERR 3	16....	

*) insert cross at seen display result.

**IN CASE OF NO ERROR INDICATION;
OTHER PROBLEMS OCCURED AT:**

PLAYBACK	CD	CDR Unfinalised	CDR Finalised	CDRW Unfinalised	CDRW Finalised
Y/N					
RECORDING	CD	CDR Unfinalised	CDR Finalised	CDRW Unfinalised	CDRW Finalised
Y/N	----				

IRIS CONDITION CODE:

DESCRIPTION	CONDITION CODE
Constantly	1...
Intermittently	2...
After a while	3...
In a hot environment	4...
In a cold environment	5...

IRIS SYMPTOM CODE CONCERNING AUDIO

Audio	Audio	Audio	Audio	Audio
No sound	Level	Quality	Noisy	Poor recording
.51.	.52.	.53.	.54.	.56.

OTHER COMPLAINT DESCRIPTION :
(IRIS SYMPTOM CODE:)

Return the defective module complete assembled in original package to:

Invoice to:

Philips Consumer Electronics B.V. 670005
 Philips Consumer Service - F&A Reporting
 Glaslaan 2, Building SBP5
 5616 LW Eindhoven
 The Netherlands

Ship to:

Philips Consumer Electronics B.V. 676723
 LO PCS WAREHOUSING
 Glaslaan 2, Building SBI p
 5616 LW Eindhoven
 The Netherlands
 ATT: Mr. C. Lieberwirth

CORRECTIVE ACTION/SOLUTION

(to be filled in at central repair workshop):

Report number:.....

Iris repair code:.....
