

marantz® SERVICE BULLETIN		Date: 15-May.-2003	Model: DR6000, DR6050, CDR631, CDR500
		Page: 1 / 1	REF.NBR: MZ02-031
Circulation:	Application:	Subject: Replace the Chip capacitor on the CDR module of MAR770/MAR775.	
x for information customer complaint in case of service mandatory	See Below		
		Int.ref:	

[PHENOMENON]

The chip capacitor is likely to be damaged in the inconsistency of voltage proof.
But, a problem symptom doesn't appear.

[SOLUTION]

The chip capacitor is changed to **0.1uF/50V** on the CDR Module of MAR770/MAR775.

POS.NO. : **2725**
2726
2727

Refer to the following of the service manual.

MAR770/MAR775 CDR Module (service manual part no.: 385K855020)

CDR MAIN BOARD – BOTTOM VIEW : POWER PART TESTPOINTS

CDR 3rd gen. **7.** **GB70** position **B5**

[NECESSARY PART]

DK98104300 (0.1uF/50V)

[REMARKS]

This improvement has been done in the production line after
the Lot number MZxxxxxx17xxxx and later.(DR6000)
the Lot number MZxxxxxx13xxxx and later.(DR6050)
the Lot number MZxxxxxx15xxxx and later.(CDR631)
the Lot number MZxxxxxx11xxxx and later.(CDR500)

The Lot number is mentioned the serial number label on the rear panel.
(ex.MZxxxxxx17xxxx)

Approved by **S.NAGAO**

Written by

marantz® SERVICE BULLETIN		Date: 22-Nov-01	Model: DR4050/DR6000/DR605 0CDR500/CDR631
		Page: 1/1	REF.NB MZ01-019
Circulation:		Application:	
x for information customer complaint in case of service mandatory		See below	
		Subject: Improvement for inoperable all buttons	
		Int.ref:	

[PHENOMENON]

While CD is played or CD-R/RW is recorded, the FL display is frozen and all buttons will not be worked. (except POWER button.)

[SOLUTION]

Replace the DASP IC <**POS No.7701**> with a new one (**8204 056 03460, QC05603460**).

[REMARK]

<Application LOT number>

- DR4050: 01 - 11 LOT
- DR6000: 01 - 16 LOT
- DR6050: 01 - 12 LOT
- CDR500: 01 - 10 LOT
- CDR631: 01 - 14 LOT

This improvement has been done in the production line after
the LOT number "12" and later. (DR4050)
the LOT number "17" and later. (DR6000)
the LOT number "13" and later. (DR6050)
the LOT number "11" and later. (CDR500)
the LOT number "15" and later. (CDR631)

The lot number and the service modification code are mentioned in the serial number label on the rear panel. (ex. **MZxxxxxx12xxxx**)

marantz® SERVICE BULLETIN		Date: 15-May.-2003	Model: DR6050,CDR500
		Page: 1 / 1	REF.NBR: MZ02-035
Circulation:		Application:	
x for information customer complaint in case of service mandatory		See Below	
		Subject: Miss clamp problem of CD single	
		Int.ref:	

[PHENOMENON]

The OPEN/CLOSE movement of disc tray is fast, It may become a CD single [8cm(3in.)] clamp defect.

[SOLUTION]

15k ohm resistor is soldered to the **Pos.No.3114** in parallel.

The object of PCB: CD MAIN BOARD of CD Module MAR1250
(Refer to the CDR500 service manual 2-13 page of MAR1250.)

This is Pos.No.3114

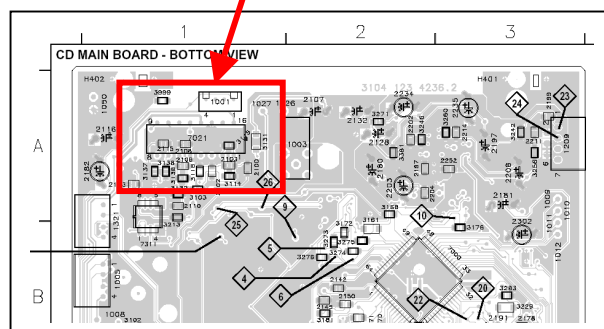
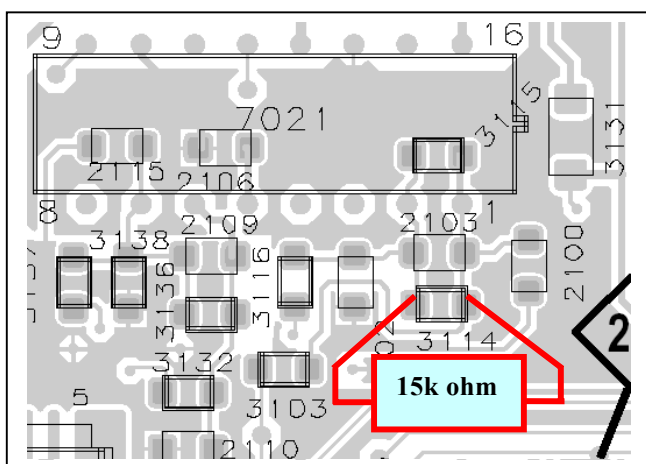

[NECESSARY PART]

15k ohm GD05153160

[REMARKS]

The countermeasure apply to this claim only.

[REMARKS]

This improvement has been done in the production line as follows.
the Lot number MZxxxxxx21xxxx and after.(DR6050)
the Lot number MZxxxxxx26xxxx and after.(CDR500)

The Lot number is mentioned the serial number label on the rear panel.
(ex.MZxxxxxx21xxxx)

Approved by **S.NAGAO**

Written by