

Service
Service
Service

TS5400
DS5400

Service Manual

TABLE OF CONTENTS

	Page
Mechanical Instructions	1
Electrical diagrams	2
Mainboard component layout	3
Mechanical & Electrical Parts list	4
Mechanical Instructions - Docking station	5
Electrical diagrams - Docking station	6
Charge board component layout	7
Mechanical & Electrical Parts list - Docking station	8

MECHANICAL INSTRUCTIONS -

Set Disassembly

- 1. Remove battery lid
- 2. Remove battery
- 3. Remove 2 x screw (Torx screw 2x6)

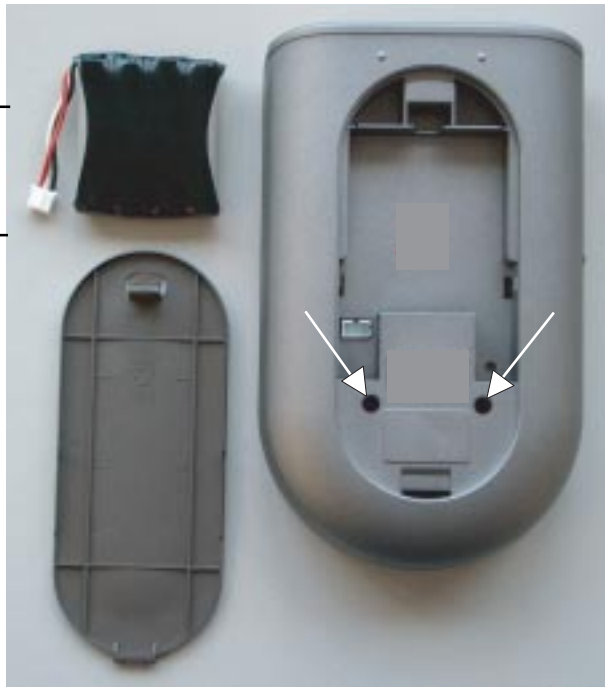

- 4. Put a sharp knife between toppart and bottompart and use this as lever to separate the two parts. see picture

Overview snapholes

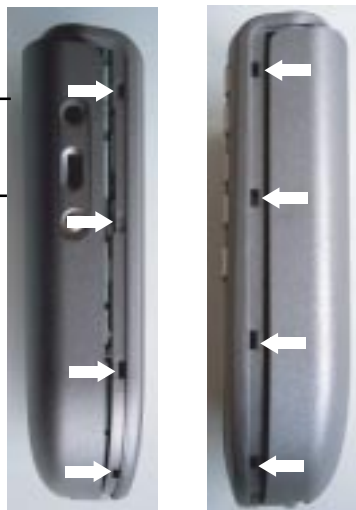

MECHANICAL INSTRUCTIONS -

Disassembly LCD & Buttons

1. Remove 5 x screw (Torx 2x6) see arrows.
2. Remove the printboard assy from the toppart assy

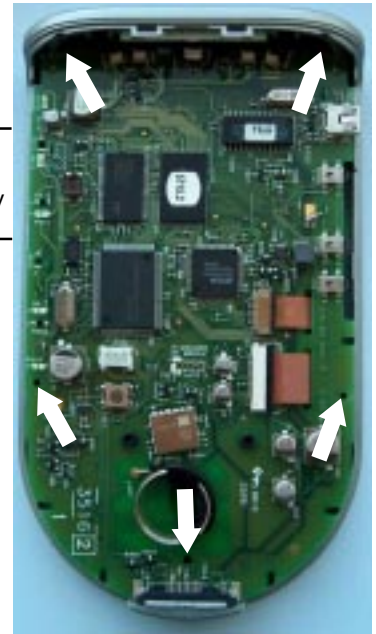

Fig.3

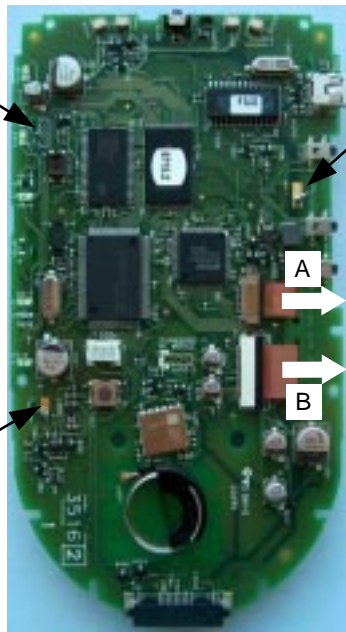

Fig.1

A

B

Disassembly LCD & Mainbord

- 1a. Desolder the 2 fixation points. see for detail fig.1 & 2
- 2a. Bend the 3 lips straight. see for detail fig.1 & 2 & 3
- 3a Remove the two flex cable. see arrow A and B
- 4a Remove LCD from the mainbord.

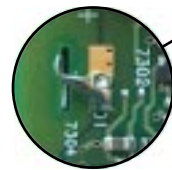
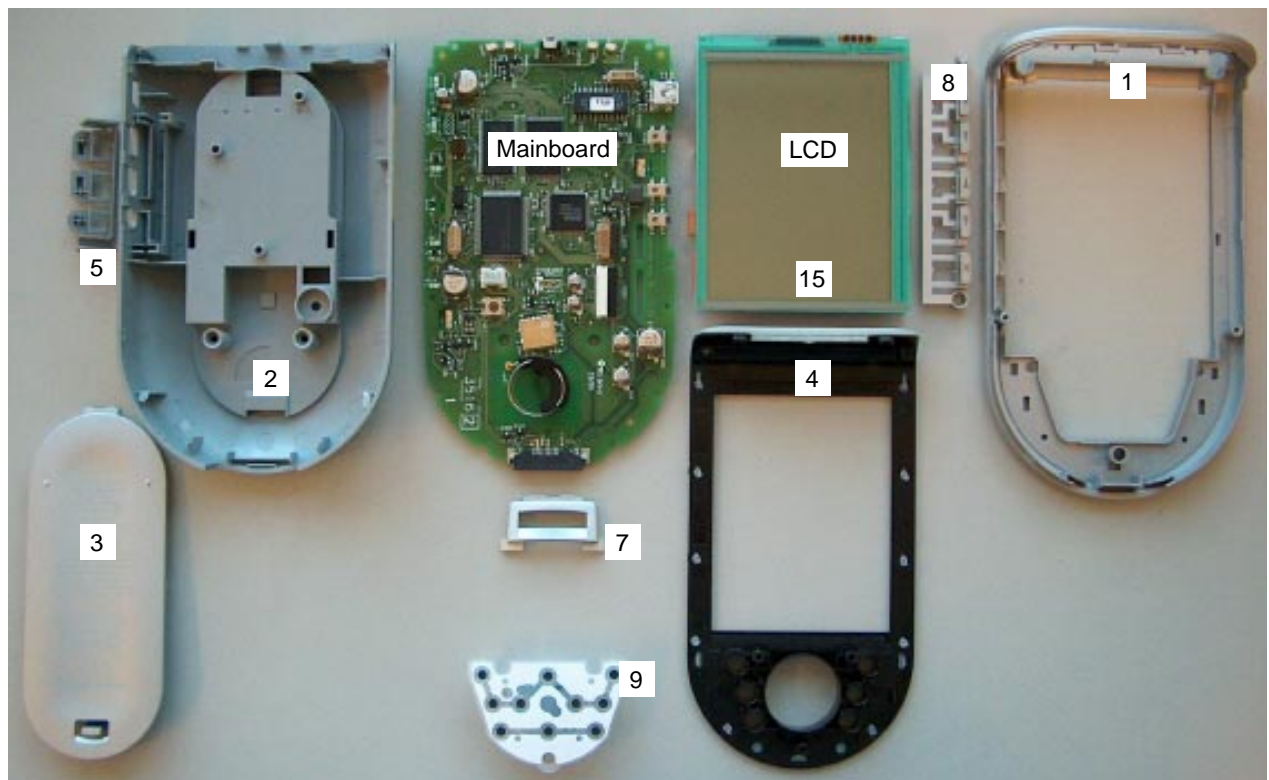

Fig.2

Overview disassembled parts



MECHANICAL INSTRUCTIONS

Set Reassembly

1. Put toppart (*item 1) and IR-window assy (*item 4) together.
2. Place toppart assy (*item1 & item 4) upside down.
3. Place LCD keymat assy (*item 9).
4. Place LCD assy (*item 15) in the toppart assy.
5. Place action keys (*item 8).

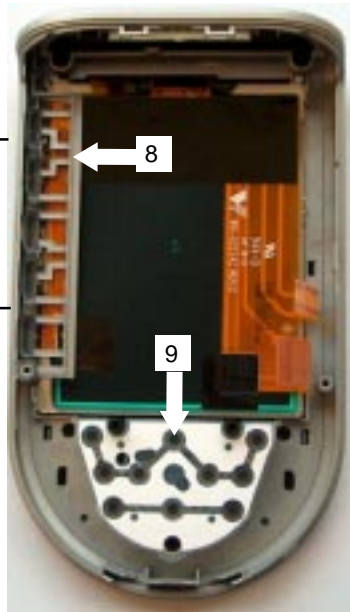
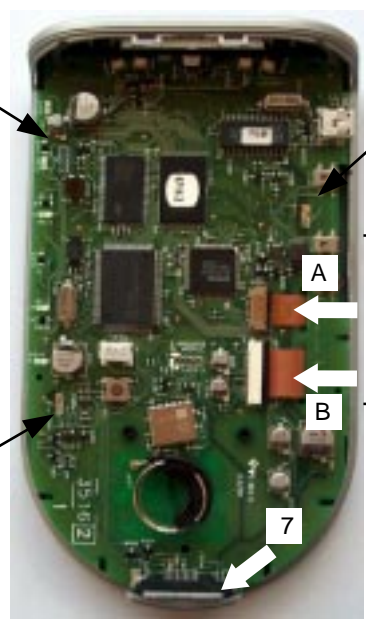

Fig.3



Fig.1



6. Place mainboard.
7. Bend the 3 lips and soldering two lips . see detail fig.1 & 2 & 3.
8. Connect the two flex cable. see arrow A and B.
9. Place Doc.plug assy (*item 7).

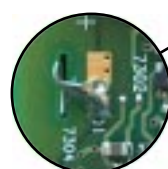

Fig.2

10. Mount the 5 screws. see arrows.



11. Place bottom part assy (*item 2).
12. Mount the two screws. see arrows.
13. Place batterypack.
14. Place batterylid assy (item 3).

* For items see overview disassembled parts

ELECTRICAL DIAGRAM

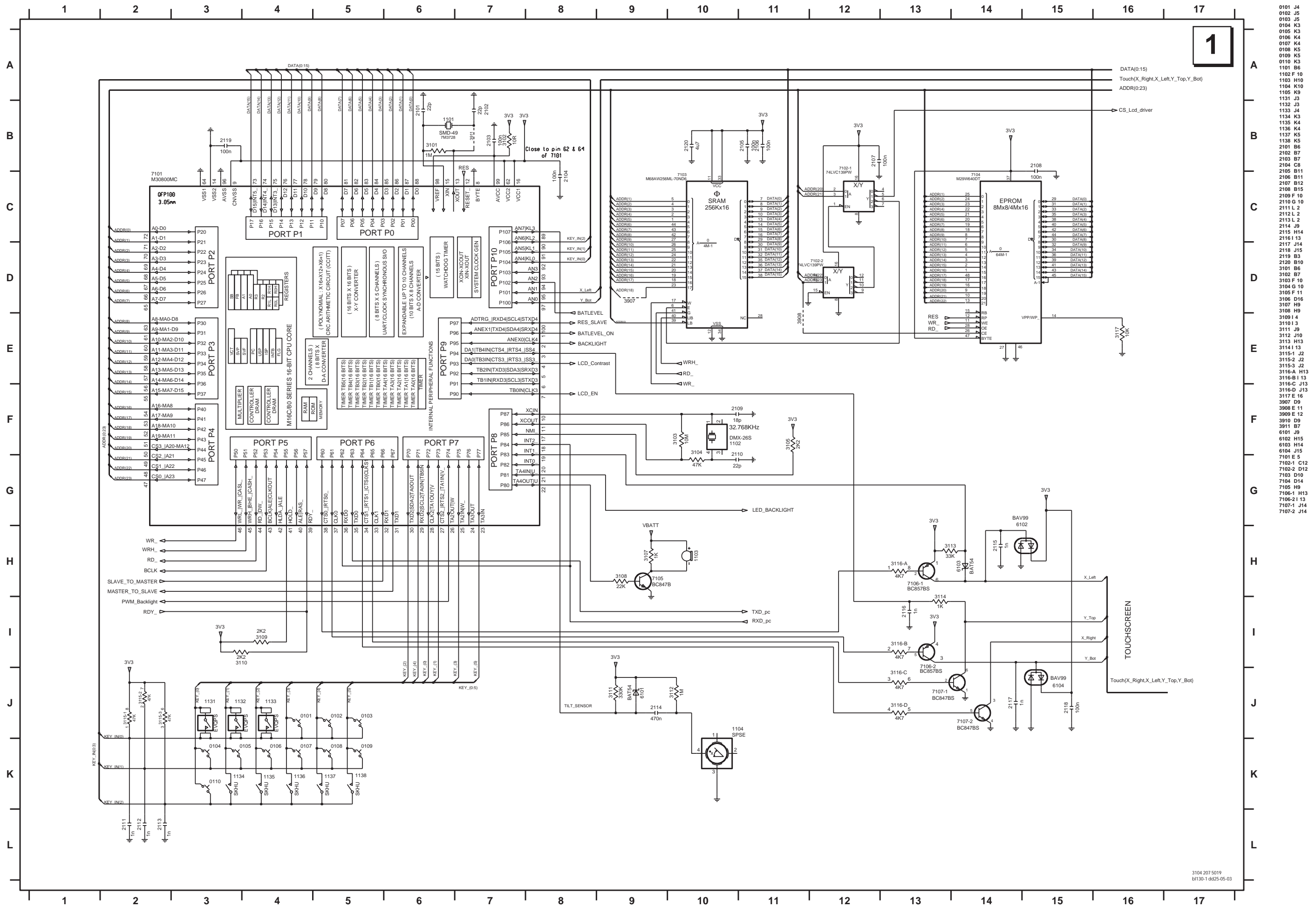

- 0101 J4
- 0102 J5
- 0103 J5
- 0104 K3
- 0105 K3
- 0106 K4
- 0107 K4
- 0108 K5
- 0109 K5
- 0110 K3
- 1101 B6
- 1102 F 10
- 1103 H10
- 1104 K10
- 1105 K9
- 1131 J3
- 1132 J3
- 1133 J4
- 1134 K3
- 1135 K4
- 1136 K4
- 1137 K5
- 1138 K5
- 2101 B6
- 2102 B7
- 2103 B7
- 2104 C8
- 2105 B11
- 2106 B11
- 2107 B12
- 2108 B15
- 2109 F 10
- 2110 G 10
- 2111 L 2
- 2112 L 2
- 2113 L 2
- 2114 J9
- 2115 H14
- 2116 I 13
- 2117 B14
- 2118 J15
- 2119 B3
- 2120 B7
- 3101 B5
- 3102 B7
- 3103 F 10
- 3104 G 10
- 3105 F 11
- 3106 D16
- 3107 H9
- 3108 H9
- 3109 I 4
- 3110 I 3
- 3111 J9
- 3112 J10
- 3113 H13
- 3114 I 13
- 3115 J2
- 3115-2 J2
- 3115-3 J2
- 3116-A H13
- 3116-B I 13
- 3116-C J13
- 3116-D J13
- 3117 E 16
- 3117 E 16
- 3907 D9
- 3908 E 11
- 3909 E 12
- 3910 D9
- 6101 B7
- 6101 J9
- 6102 H15
- 6103 H14
- 6104 J5
- 7101 E 5
- 7102-1 C12
- 7102-2 D12
- 7103 D10
- 7104 D14
- 7105 H9
- 7106-1 H13
- 7106-2 I 13
- 7107-1 J14
- 7107-2 J14

ELECTRICAL DIAGRAM

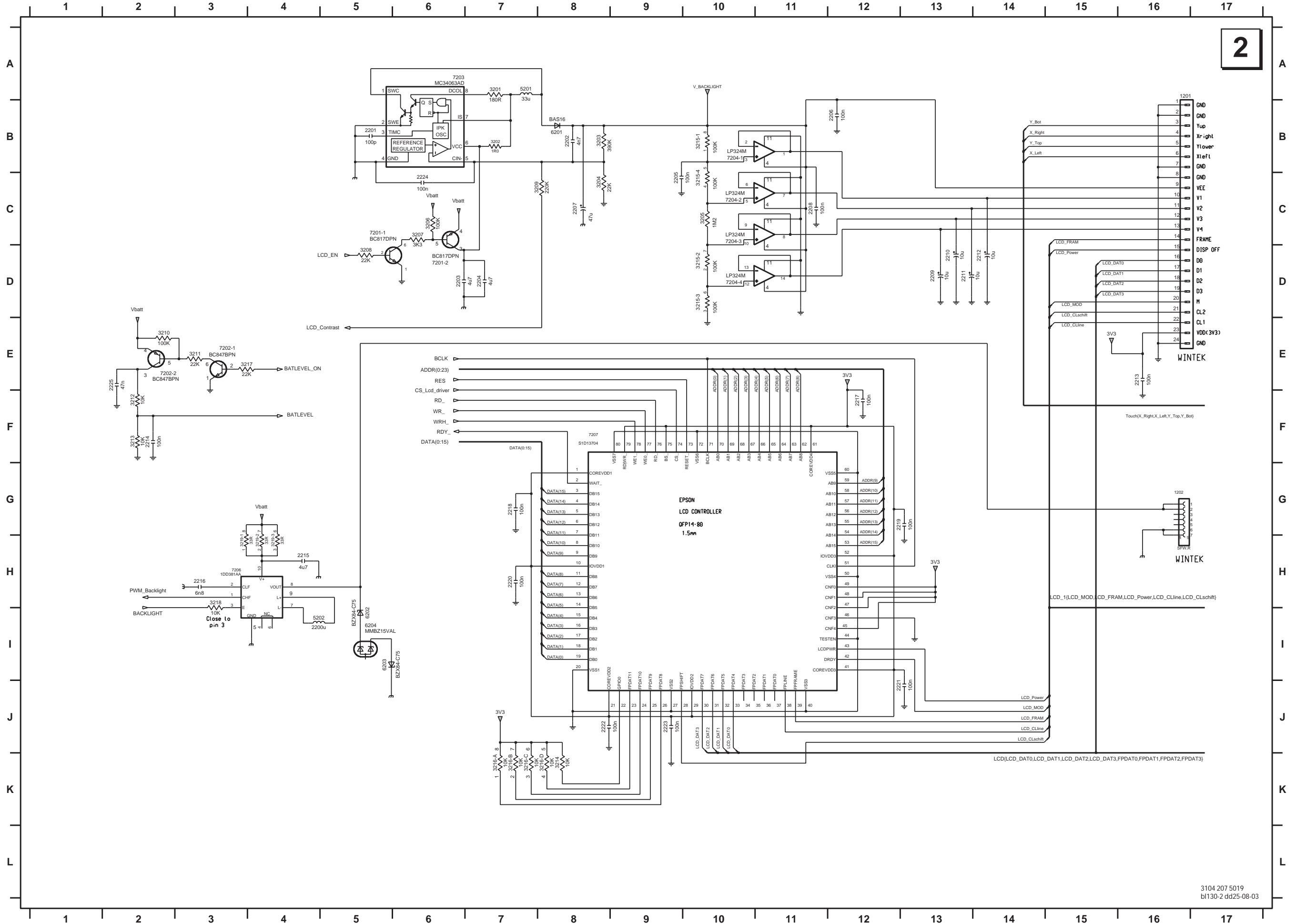

- 1201 C16
- 1202 G 16
- 2201 B5
- 2202 B8
- 2203 D6
- 2204 D7
- 2205 C9
- 2206 B12
- 2207 C8
- 2208 C11
- 2209 D13
- 2210 D13
- 2211 D13
- 2212 D14
- 2213 E 16
- 2214 F 2
- 2215 H4
- 2216 H3
- 2217 F 12
- 2218 G 7
- 2219 G 13
- 2220 H7
- 2221 J13
- 2222 J8
- 2223 J9
- 2224 C6
- 2225 E 2
- 3201 A7
- 3202 B7
- 3203 B8
- 3204 C8
- 3205 C10
- 3206 C6
- 3207 C6
- 3208 D5
- 3209 C8
- 3210 E 2
- 3211 E 3
- 3212 F 2
- 3213 F 2
- 3214 K8
- 3215-1 B10
- 3215-2 D10
- 3215-3 D10
- 3215-4 C10
- 3216-A K7
- 3216-B K7
- 3216-C K7
- 3216-D K8
- 3217 E 3
- 3218 H3
- 3219-1 H3
- 3219-2 H4
- 3219-3 H4
- 3220 H5
- 5201 A7
- 52021 4
- 6201 B8
- 62021 5
- 62031 5
- 62041 5
- 7201-1 D5
- 7201-2 C6
- 7202-1 E 3
- 7202-2 E 2
- 7203 B6
- 7204-1 B11
- 7204-2 C11
- 7204-3 C11
- 7204-4 D11
- 7206 H4
- 7207 H10

2

ELECTRICAL DIAGRAM

3

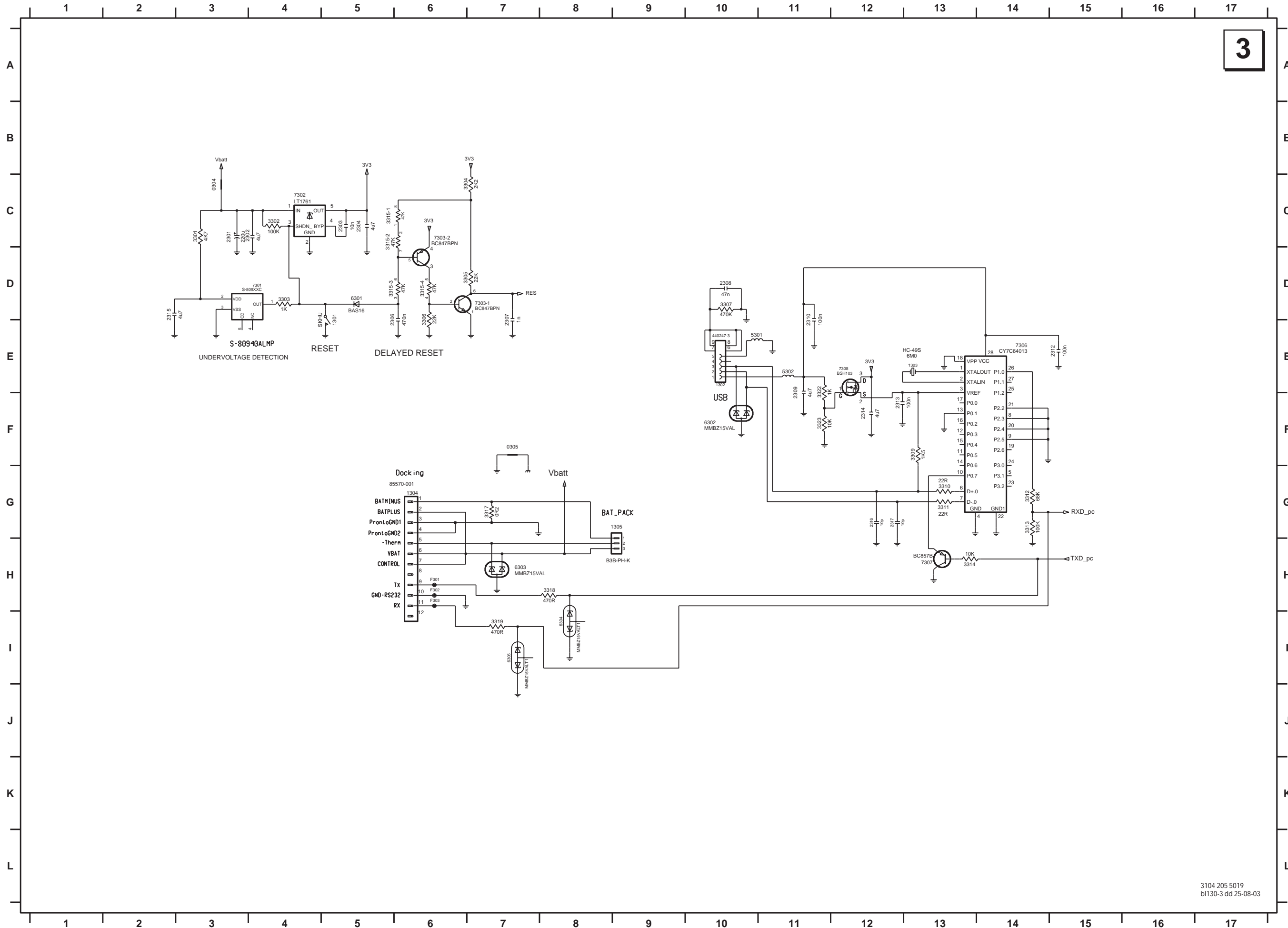

- 0304 C3
- 0305 F 7
- 1301 D5
- 1302 E 10
- 1303 E 13
- 1304 H6
- 1305 G 8
- 2301 C3
- 2302 C4
- 2303 C5
- 2304 C5
- 2305 D3
- 2306 D6
- 2307 D7
- 2308 D10
- 2309 E 11
- 2310 D11
- 2311 D12
- 2312 E 15
- 2313 F 12
- 2314 F 12
- 2315 D2
- 2316 G 12
- 2317 G 12
- 3301 C3
- 3302 C4
- 3303 D4
- 3304 C7
- 3305 D7
- 3306 D6
- 3307 D10
- 3308 E 13
- 3309 F 13
- 3310 G 13
- 3311 G 13
- 3312 G 14
- 3313 G 14
- 3314 H13
- 3315-1 C6
- 3315-2 C6
- 3315-3 D6
- 3315-4 D6
- 3317 G 7
- 3318 H8
- 3319 F 7
- 3320 E 11
- 3323 F 11
- 3324 D3
- 3325 G 7
- 5301 E 10
- 5302 E 11
- 5303 D12
- 6301 D5
- 6302 F 10
- 6303 H7
- 6304 G 8
- 6305 F 7
- 7301 D3
- 7302 C4
- 7303-1 D6
- 7303-2 D6
- 7305 D12
- 7306 F 14
- 7307 H13
- 7308 E 12
- F301 H6
- F302 H6
- F303 H6

ELECTRICAL DIAGRAM

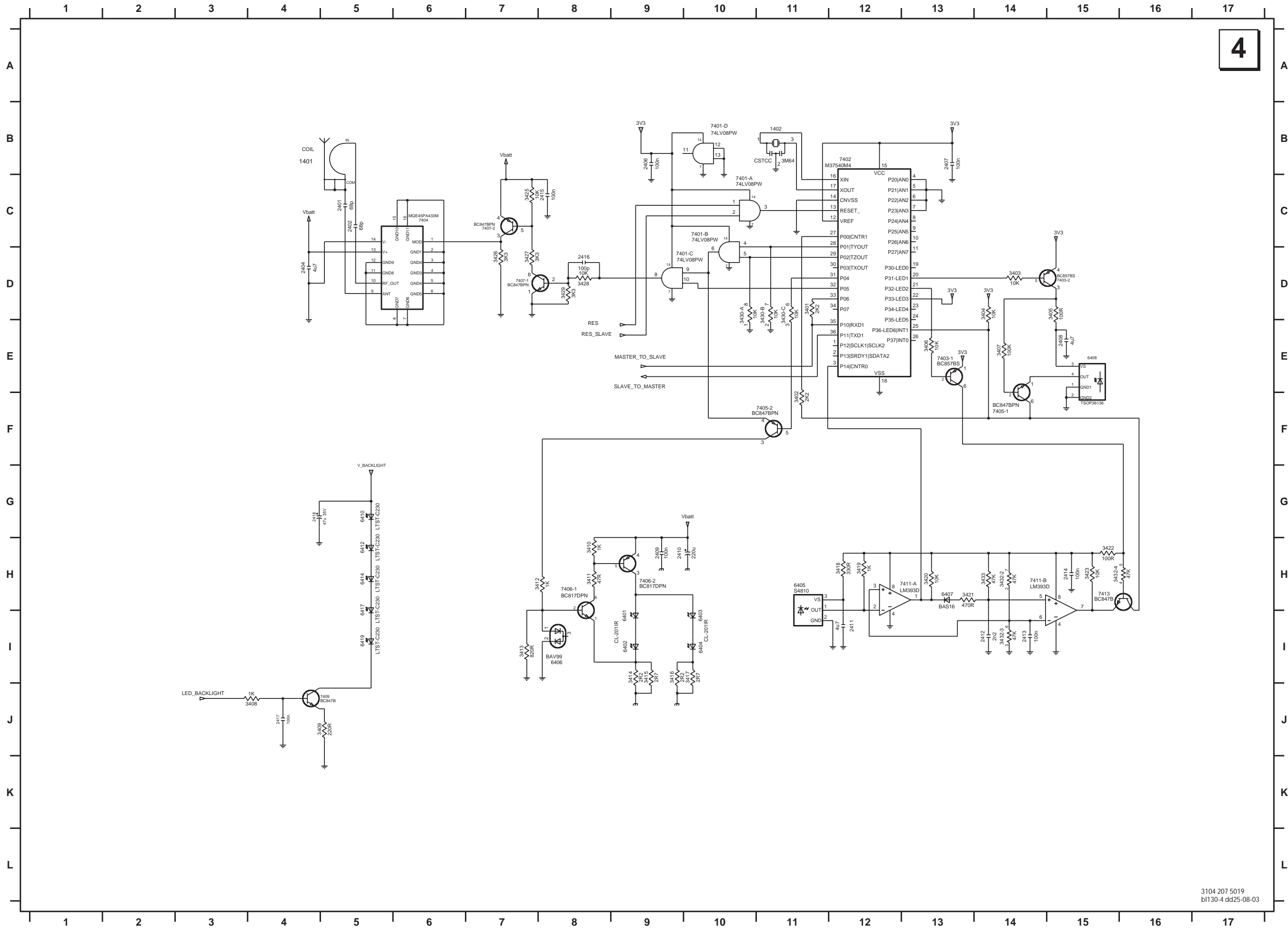

COMPONENT LAYOUT SIDE-A VIEW

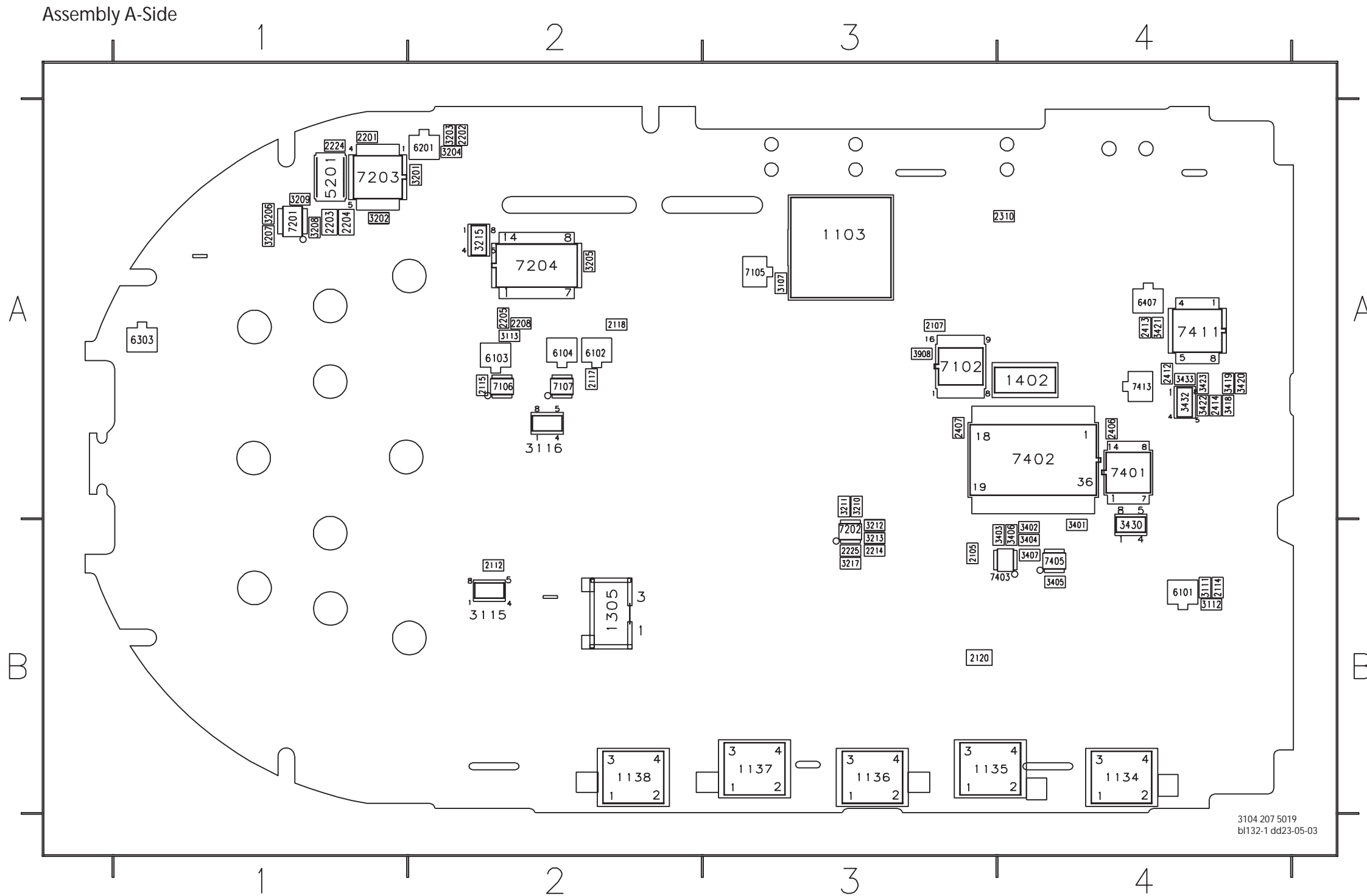

1103	A3
1105	B4
1106	B4
1107	B4
1108	B3
1109	B3
1110	B3
1111	B3
1112	B3
1113	B3
1114	B2
1115	B2
1116	B2
1117	B2
1118	A4
1119	A4
1120	A4
1121	A4
1122	A4
1123	A4
1124	A4
1125	A4
1126	A4
1127	A4
1128	A4
1129	A4
1130	A4
1131	A4
1132	A4
1133	A4
1134	A4
1135	A4
1136	A4
1137	A4
1138	A4
1139	A4
1140	A4
1141	A4
1142	A4
1143	A4
1144	A4
1145	A4
1146	A4
1147	A4
1148	A4
1149	A4
1150	A4
1151	A4
1152	A4
1153	A4
1154	A4
1155	A4
1156	A4
1157	A4
1158	A4
1159	A4
1160	A4
1161	A4
1162	A4
1163	A4
1164	A4
1165	A4
1166	A4
1167	A4
1168	A4
1169	A4
1170	A4
1171	A4
1172	A4
1173	A4
1174	A4
1175	A4
1176	A4
1177	A4
1178	A4
1179	A4
1180	A4
1181	A4
1182	A4
1183	A4
1184	A4
1185	A4
1186	A4
1187	A4
1188	A4
1189	A4
1190	A4
1191	A4
1192	A4
1193	A4
1194	A4
1195	A4
1196	A4
1197	A4
1198	A4
1199	A4
1200	A4
1201	A4
1202	A4
1203	A4
1204	A4
1205	A4
1206	A4
1207	A4
1208	A4
1209	A4
1210	A4
1211	A4
1212	A4
1213	A4
1214	A4
1215	A4
1216	A4
1217	A4
1218	A4
1219	A4
1220	A4
1221	A4
1222	A4
1223	A4
1224	A4
1225	A4
1226	A4
1227	A4
1228	A4
1229	A4
1230	A4
1231	A4
1232	A4
1233	A4
1234	A4
1235	A4
1236	A4
1237	A4
1238	A4
1239	A4
1240	A4
1241	A4
1242	A4
1243	A4
1244	A4
1245	A4
1246	A4
1247	A4
1248	A4
1249	A4
1250	A4
1251	A4
1252	A4
1253	A4
1254	A4
1255	A4
1256	A4
1257	A4
1258	A4
1259	A4
1260	A4
1261	A4
1262	A4
1263	A4
1264	A4
1265	A4
1266	A4
1267	A4
1268	A4
1269	A4
1270	A4
1271	A4
1272	A4
1273	A4
1274	A4
1275	A4
1276	A4
1277	A4
1278	A4
1279	A4
1280	A4
1281	A4
1282	A4
1283	A4
1284	A4
1285	A4
1286	A4
1287	A4
1288	A4
1289	A4
1290	A4
1291	A4
1292	A4
1293	A4
1294	A4
1295	A4
1296	A4
1297	A4
1298	A4
1299	A4
1300	A4
1301	A4
1302	A4
1303	A4
1304	A4
1305	A4
1306	A4
1307	A4
1308	A4
1309	A4
1310	A4
1311	A4
1312	A4
1313	A4
1314	A4
1315	A4
1316	A4
1317	A4
1318	A4
1319	A4
1320	A4
1321	A4
1322	A4
1323	A4
1324	A4
1325	A4
1326	A4
1327	A4
1328	A4
1329	A4
1330	A4
1331	A4
1332	A4
1333	A4
1334	A4
1335	A4
1336	A4
1337	A4
1338	A4
1339	A4
1340	A4

3104 207 5019 bl132-1 dd23-05-03

MECHANICAL & ELECTRICAL PARTS LIST

MECHANICAL PARTS

1	3104 207 80420	TOPPART ASSY
2	3104 207 80430	BOTTOMPART ASSY
3	3104 207 80520	BATT. LID ASSY TS5400/N1M/T1M
3	3104 207 80440	BATT. LID ASSY TS5400/U1S
4	3104 207 80470	IR- WINDOW + BEZEL ASSY
5	3104 207 80480	SIDE BUTTONS ASSY
7	3104 207 80490	DOC PLUG INSERT ASSY
8	3104 207 80500	ACTION KEYS ASSY
9	3104 207 80510	LOWER KEYMAT ASSY
15	3104 200 51760	LCD ASSY

ELECTRICAL PARTS

34	3104 200 51260	BATTERYPACK
	3104 207 14850	MAINBOARD TS5400 /N1M/T1M (3104 207 40140)
	3104 207 14860	MAINBOARD TS5400 /U1S (3104 207 40180)
	3104 200 51200	POWER ADAPTER /N1M - EUR.
	3104 200 51210	POWER ADAPTER /T1M - UK
	3104 200 51190	POWER ADAPTER /U1S - US
	3140 117 69600	USB CABLE



POWER ADAPTOR



USB CABLE



BATTERYPACK

Note: Only the parts mentioned in this list are normal service parts

For more information:

E-mail: erik.gybels@philips.com

Overview mechanical parts

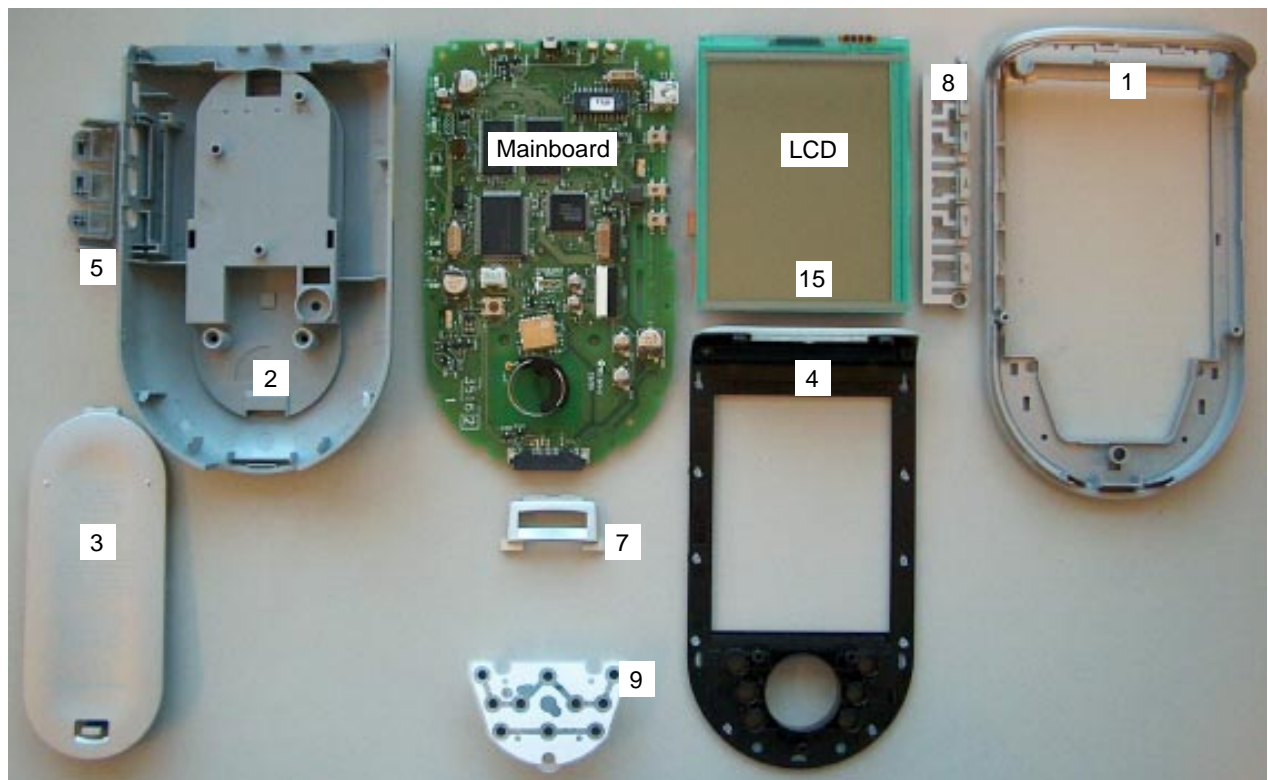

ELECTRICAL PARTS LIST

MISCELLANEOUS

1101 2422 543 01244 RES XTL SM 7M3728 16P
 1102 2422 543 00937 RES XTL SM 32K76 12P5
 1103 2422 527 01014 BUZZER SM 12X12
 1104 2422 129 16301 SWI TILT SM 40DEG
 1131 2422 128 03024 SWI TACT SM 1P 50MA12V
 1132 2422 128 03024 SWI TACT SM 1P 50MA12V
 1133 2422 128 03024 SWI TACT SM 1P 50MA12V
 1134 2422 128 02435 SWI TACT SM 50MA 12V
 1135 2422 128 02435 SWI TACT SM 50MA 12V
 1136 2422 128 02435 SWI TACT SM 50MA 12V
 1137 2422 128 02435 SWI TACT SM 50MA 12V
 1138 2422 128 02435 SWI TACT SM 50MA 12V
 1201 2422 025 16177 CON H 24P F 0.50 SM
 1202 2422 025 17855 CON BM H 7P F 1.00
 1301 2422 128 02435 SWI TACT SM 50MA

1302 2422 025 18265 SOC USB H 5P F 0.8
 1303 2422 543 01334 RES XTL SM 6MHZ
 1304 8204 161 43491 CON BM SM FCI-85570
 1305 2422 025 11072 CON V 3P M 2.00
 1401 3104 207 80200 RF TSM ANT ASSY 18L

1402 2422 540 98541 RES CER CSTCC6.00MG

CAPACITORS

2101 2238 867 15229 CER1 0603 NP0 50V 22P
 2102 2238 867 15229 CER1 0603 NP0 50V 22P
 2103 2238 916 19849 CER2 0603 Y5V 25V 100N
 2104 2238 916 19849 CER2 0603 Y5V 25V 100N
 2105 2238 916 19849 CER2 0603 Y5V 25V 100N

2106 2238 916 19849 CER2 0603 Y5V 25V 100N
 2107 2238 916 19849 CER2 0603 Y5V 25V 100N
 2108 2238 916 19849 CER2 0603 Y5V 25V 100N
 2109 2238 867 15189 CER1 0603 NP0 50V 18P
 2110 2238 867 15229 CER1 0603 NP0 50V 22P

2111 2238 586 15623 CER2 0603 X7R 50V 1N
 2112 2238 586 15623 CER2 0603 X7R 50V 1N
 2113 2238 586 15623 CER2 0603 X7R 50V 1N
 2114 2238 246 19858 CER2 0603 Y5V 10V 470N
 2115 2238 586 15623 CER2 0603 X7R 50V 1N

2116 2238 586 15623 CER2 0603 X7R 50V 1N
 2117 2238 586 15623 CER2 0603 X7R 50V 1N
 2118 2238 916 19849 CER2 0603 Y5V 25V 100N
 2119 2238 916 19849 CER2 0603 Y5V 25V 100N
 2120 2020 552 96305 CER2 0805 Y5V 10V 4U7

2201 2238 867 15101 CER1 0603 NP0 50V 100P
 2202 2238 586 15632 CER2 0603 X7R 50V 4N7
 2203 2020 552 96305 CER2 0805 Y5V 10V 4U7
 2204 2020 552 96305 CER2 0805 Y5V 10V 4U7
 2205 2238 916 19849 CER2 0603 Y5V 25V 100N

2206 2238 916 19849 CER2 0603 Y5V 25V 100N
 2207 2020 024 90751 ELCAP SM WX 35V 47U
 2208 2238 916 19849 CER2 0603 Y5V 25V 100N
 2209 2020 024 90163 ELCAP SM WX 16V 10U
 2210 2020 024 90163 ELCAP SM WX 16V 10U

2211 2020 024 90166 ELCAP SM WX 35V 10U
 2212 2020 024 90166 ELCAP SM WX 35V 10U
 2213 2238 916 19849 CER2 0603 Y5V 25V 100N
 2214 2238 916 19849 CER2 0603 Y5V 25V 100N

CAPACITORS

2215 2020 552 96305 CER2 0805 Y5V 10V 4U7
 2216 2238 586 15634 CER2 0603 X7R 50V 6N8
 2217 2238 916 19849 CER2 0603 Y5V 25V 100N
 2218 2238 916 19849 CER2 0603 Y5V 25V 100N
 2219 2238 916 19849 CER2 0603 Y5V 25V 100N

2220 2238 916 19849 CER2 0603 Y5V 25V 100N
 2221 2238 916 19849 CER2 0603 Y5V 25V 100N
 2222 2238 916 19849 CER2 0603 Y5V 25V 100N
 2223 2238 916 19849 CER2 0603 Y5V 25V 100N
 2224 2238 916 19849 CER2 0603 Y5V 25V 100N

2225 2238 786 15645 CER2 0603 X7R 16V 47N
 2301 2020 024 90677 ELCAP SM WX 10V 220U
 2302 2020 552 96305 CER2 0805 Y5V 10V 4U7
 2303 2238 586 15636 CER2 0603 X7R 50V 10N
 2304 2020 552 96305 CER2 0805 Y5V 10V 4U7

2306 2238 246 19858 CER2 0603 Y5V 10V 470N
 2307 2238 586 15623 CER2 0603 X7R 50V 1N
 2308 2238 786 15645 CER2 0603 X7R 16V 47N
 2309 2020 552 96305 CER2 0805 Y5V 10V 4U7
 2310 2238 916 19849 CER2 0603 Y5V 25V 100N

2312 2238 916 19849 CER2 0603 Y5V 25V 100N
 2313 2238 916 19849 CER2 0603 Y5V 25V 100N
 2314 2020 552 96305 CER2 0805 Y5V 10V 4U7
 2315 2020 552 96305 CER2 0805 Y5V 10V 4U7
 2316 2238 867 15109 CER1 0603 NP0 50V 10P

2317 2238 867 15109 CER1 0603 NP0 50V 10P
 2401 2238 867 15689 CER1 0603 NP0 50V 68P
 2402 2238 867 15689 CER1 0603 NP0 50V 68P
 2404 2020 552 96305 CER2 0805 Y5V 10V 4U7
 2406 2238 916 19849 CER2 0603 Y5V 25V 100N

2407 2238 916 19849 CER2 0603 Y5V 25V 100N
 2408 2020 552 96305 CER2 0805 Y5V 10V 4U7
 2409 2238 916 19849 CER2 0603 Y5V 25V 100N
 2410 2020 024 90677 ELCAP SM WX 10V 220U
 2411 2020 552 96305 CER2 0805 Y5V 10V 4U7

2412 2238 586 15627 CER2 0603 X7R 50V 2N2
 2413 2238 916 19849 CER2 0603 Y5V 25V 100N
 2414 2238 916 19849 CER2 0603 Y5V 25V 100N
 2415 2238 916 19849 CER2 0603 Y5V 25V 100N
 2416 2238 867 15101 CER1 0603 NP0 50V 100P

2417 2238 916 19849 CER2 0603 Y5V 25V 100N
 2418 2020 024 90751 ELCAP SM WX 35V 47U

RESISTORS

3101 2322 702 60105 RST SM 0603 RC21 1M
 3102 2322 702 60109 RST SM 0603 RC21 10R
 3103 2322 702 60106 RST SM 0603 RC21 10M
 3104 2322 702 60473 RST SM 0603 RC21 47K
 3105 2322 702 60222 RST SM 0603 RC21 2K2

3107 2322 702 60102 RST SM 0603 RC21 1K
 3108 2322 702 60223 RST SM 0603 RC21 22K
 3109 2322 702 60222 RST SM 0603 RC21 2K2
 3110 2322 702 60222 RST SM 0603 RC21 2K2
 3111 2322 702 60334 RST SM 0603 RC21 330K

3112 2322 702 60105 RST SM 0603 RC21 1M
 3113 2322 702 60333 RST SM 0603 RC21 33K
 3114 2322 702 60102 RST SM 0603 RC21 1K

ELECTRICAL PARTS LIST

RESISTORS

3115	2350 034 10473	RST NETW ARC24 4X 47K
3116	2350 034 10472	RST NETW ARC24 4X 4K7
3117	2322 702 60103	RST SM 0603 RC21 10K
3201	2322 702 60181	RST SM 0603 RC21 180R
3202	2322 702 60108	RST SM 0603 RC21 1R
3203	2322 704 63904	RST SM 0603 RC22H 390K
3204	2322 704 62203	RST SM 0603 RC22H 22K
3205	2322 704 61205	RST SM 0603 RC22H 1M2
3206	2322 702 60104	RST SM 0603 RC21 100K
3207	2322 702 60332	RST SM 0603 RC21 3K3
3208	2322 702 60223	RST SM 0603 RC21 22K
3209	2322 702 60224	RST SM 0603 RC21 220K
3210	2322 702 60104	RST SM 0603 RC21 100K
3211	2322 702 60223	RST SM 0603 RC21 22K
3212	2322 704 61003	RST SM 0603 RC22H 10K
3213	2322 704 61003	RST SM 0603 RC22H 10K
3214	2322 702 60103	RST SM 0603 RC21 10K
3215	2350 034 10104	RST NETW ARC24 4X100K
3216	2350 034 10103	RST NETW ARC24 4X 10K
3217	2322 702 60223	RST SM 0603 RC21 22K
3218	2322 702 60103	RST SM 0603 RC21 10K
3219	2350 034 10339	RST NETW ARC24 4X 33R
3301	2322 702 60472	RST SM 0603 RC21 4K7
3302	2322 702 60104	RST SM 0603 RC21 100K
3303	2322 702 60102	RST SM 0603 RC21 1K
3304	2322 702 60222	RST SM 0603 RC21 2K2
3305	2322 702 60223	RST SM 0603 RC21 22K
3306	2322 702 60223	RST SM 0603 RC21 22K
3307	2322 702 60474	RST SM 0603 RC21 470K
3309	2322 702 60152	RST SM 0603 RC21 1K5
3310	2322 702 60229	RST SM 0603 RC21 22R
3311	2322 702 60229	RST SM 0603 RC21 22R
3312	2322 702 60683	RST SM 0603 RC21 68K
3313	2322 702 60104	RST SM 0603 RC21 100K
3314	2322 702 60103	RST SM 0603 RC21 10K
3315	2350 034 10473	RST NETW ARC24 4X 47K
3317	2350 511 15207	RST SM 0805 LRC11P 0R2
3318	2322 702 60471	RST SM 0603 RC21 470R
3319	2322 702 60471	RST SM 0603 RC21 470R
3322	2322 702 60102	RST SM 0603 RC21 1K
3323	2322 702 60103	RST SM 0603 RC21 10K
3401	2322 702 60222	RST SM 0603 RC21 2K2
3402	2322 702 60222	RST SM 0603 RC21 2K2
3403	2322 702 60103	RST SM 0603 RC21 10K
3404	2322 702 60103	RST SM 0603 RC21 10K
3405	2322 702 60101	RST SM 0603 RC21 100R
3406	2322 702 60103	RST SM 0603 RC21 10K
3407	2322 702 60104	RST SM 0603 RC21 100K
3408	2322 702 60102	RST SM 0603 RC21 1K
3409	2322 702 60221	RST SM 0603 RC21 220R
3410	2322 702 60102	RST SM 0603 RC21 1K
3411	2322 702 60479	RST SM 0603 RC21 47R
3412	2322 702 60102	RST SM 0603 RC21 1K
3413	2322 702 60821	RST SM 0603 RC21 820R
3414	2322 702 60228	RST SM 0603 RC21 2R2
3415	2322 702 60278	RST SM 0603 RC21 2R7
3416	2322 702 60228	RST SM 0603 RC21 2R2

RESISTORS

3417	2322 702 60278	RST SM 0603 RC21 2R7
3418	2322 702 60331	RST SM 0603 RC21 330R
3419	2322 702 60102	RST SM 0603 RC21 1K
3420	2322 702 60103	RST SM 0603 RC21 10K
3421	2322 702 60471	RST SM 0603 RC21 470R
3422	2322 702 60101	RST SM 0603 RC21 100R
3423	2322 702 60103	RST SM 0603 RC21 10K
3425	2322 702 60103	RST SM 0603 RC21 10K
3426	2322 702 60332	RST SM 0603 RC21 3K3
3427	2322 702 60332	RST SM 0603 RC21 3K3
3428	2322 702 60103	RST SM 0603 RC21 10K
3429	2322 702 60332	RST SM 0603 RC21 3K3
3430	2350 034 10103	RST NETW ARC24 4X 10K
3432	2350 034 10473	RST NETW ARC24 4X 47K
3433	2322 702 60473	RST SM 0603 RC21 47K
3434	2322 702 96001	RST JUMP. MAX 0R05
3907	2322 702 96001	RST JUMP. MAX 0R05
3908	2322 702 96001	RST JUMP. MAX 0R05
3911	2322 702 96001	RST JUMP. MAX 0R05

FILTERS & COILS

5201	2422 535 95078	IND FXD SM 1812 33U
5202	2422 536 00373	IND FXD SM 2220 2200U
5301	2422 549 41222	IND FXD EMI 100MHZ
5302	2422 549 41222	IND FXD EMI 100MHZ

DIODES

6101	9337 422 80215	DIO SIG SM BAT54
6102	9332 153 70215	DIO SIG SM BAV99
6103	9337 422 80215	DIO SIG SM BAT54
6104	9332 153 70215	DIO SIG SM BAV99
6201	9334 606 20215	DIO SIG SM BAS16
6202	9333 884 30215	DIO SM BZX84-C75
6203	9333 884 30215	DIO SM BZX84-C75
6204	9322 168 12685	DIO SM MMBZ15VAL
6301	9334 606 20215	DIO SIG SM BAS16
6302	9322 168 12685	DIO SM MMBZ15VAL
6303	9322 168 12685	DIO SM MMBZ15VAL
6304	9322 168 12685	DIO SM MMBZ15VAL
6305	9322 168 12685	DIO SM MMBZ15VAL
6401	9322 172 08685	LED IR SM CL-201IR-X
6402	9322 172 08685	LED IR SM CL-201IR-X
6403	9322 172 08685	LED IR SM CL-201IR-X
6404	9322 172 08685	LED IR SM CL-201IR-X
6405	9322 105 11682	OPT SEN S4810
6406	9332 153 70215	DIO SIG SM BAV99
6407	9334 606 20215	DIO SIG SM BAS16
6408	9322 197 80668	IR RECEIVER TSOP36136
6411	9322 200 18685	LED SM LTST-C230TBKT
6412	9322 200 18685	LED SM LTST-C230TBKT
6414	9322 200 18685	LED SM LTST-C230TBKT
6417	9322 200 18685	LED SM LTST-C230TBKT
6419	9322 200 18685	LED SM LTST-C230TBKT

ELECTRICAL PARTS LIST

TRANSISTORS & IC's

7101	9322 150 83671	IC SM M30800MC-001FP
7102	9351 960 10118	IC SM 74LVC139PW
7103	9322 195 36668	IC M68AW256ML-70ND6
7104	3104 208 57161	TS5400/N1M + /T1M
7105	9335 895 90215	TRA SIG SM BC847B
7106	9340 425 10115	TRA SIG SM BC857BS
7107	9340 425 20115	TRA SIG SM BC847BS
7201	9340 573 20115	TRA SIG SM BC817DPN
7202	9340 425 30115	TRA SIG SM BC847BPN
7203	9322 033 40668	IC SM MC34063AD
7204	9322 111 81668	IC SM LP324M
7206	9322 187 74688	IC SM D381A
7207	9322 184 81671	IC SM S1D13704F00A
7301	9322 185 27685	IC SM S-80940CLMC-G7A
7302	9322 171 42685	IC SM LT1761ES5-3.3
7303	9340 425 30115	TRA SIG SM BC847BPN
7306	3104 208 55794	CYPRESS USB INTERFASSY
7307	9335 897 60215	TRA SIG SM BC857B
7308	9340 547 13215	FET SIG SM BSH103
7401	9351 742 80118	IC SM 74LV08PW
7402	3104 208 83821	IC- SM M37540M4-090FP
7403	9340 425 10115	TRA SIG SM BC857BS
7404	2722 171 08795	OSC433Mhz only for /N1M/T1M
7404	2722 171 08814	OSC 418Mhz only for /U1S
7405	9340 425 30115	TRA SIG SM BC847BPN
7406	9340 573 20115	TRA SIG SM BC817DPN
7407	9340 425 30115	TRA SIG SM BC847BPN
7409	9335 895 90215	TRA SIG SM BC847B
7411	9339 575 30668	IC SM LM393D
7413	9335 895 90215	TRA SIG SM BC847B



DOCKING STATION
DS5400

MECHANICAL INSTRUCTIONS

Set Disassembly - Docking station



- 1. Remove the four rubber feet
- 2. Remove 4 x screw
see picture - arrows

Overview snapholes



- 3. Put a sharp knife between toppart and bottompart and use this as lever to separate the two parts.
For the correct position of the knife see snapholes in picture

Overview disassembled parts

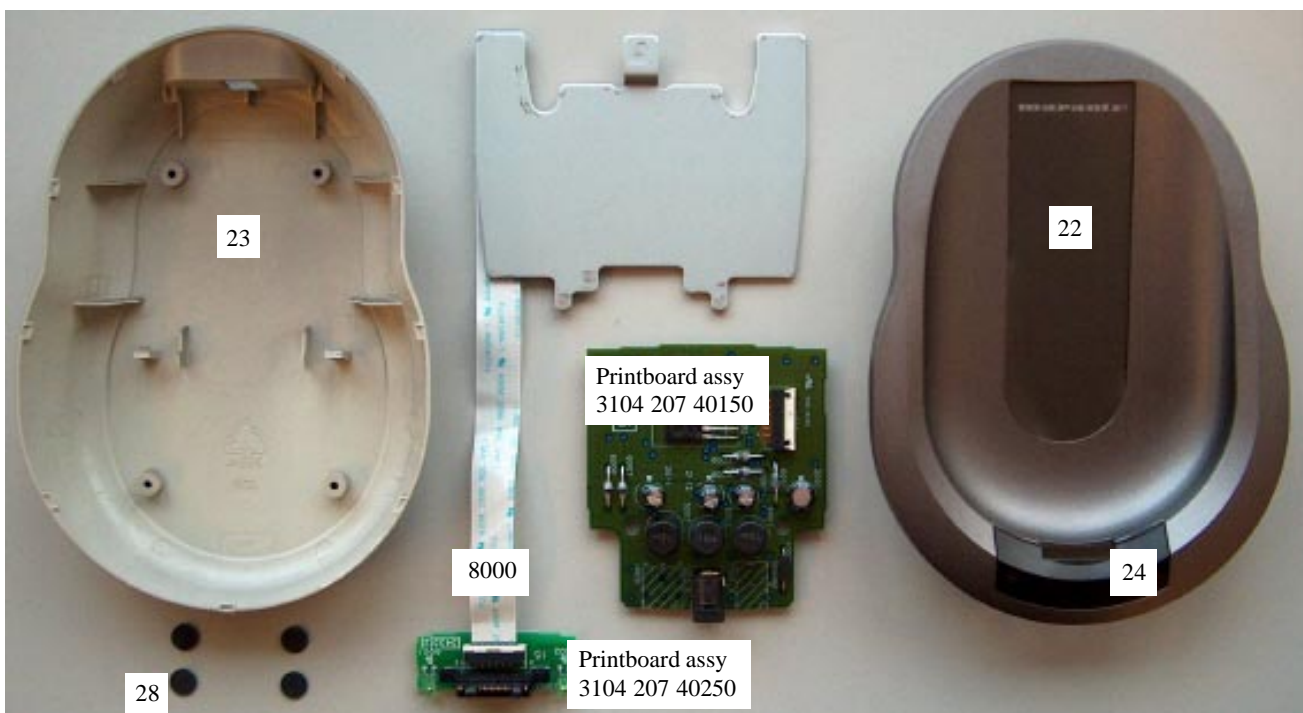

CHARGER DIAGRAM

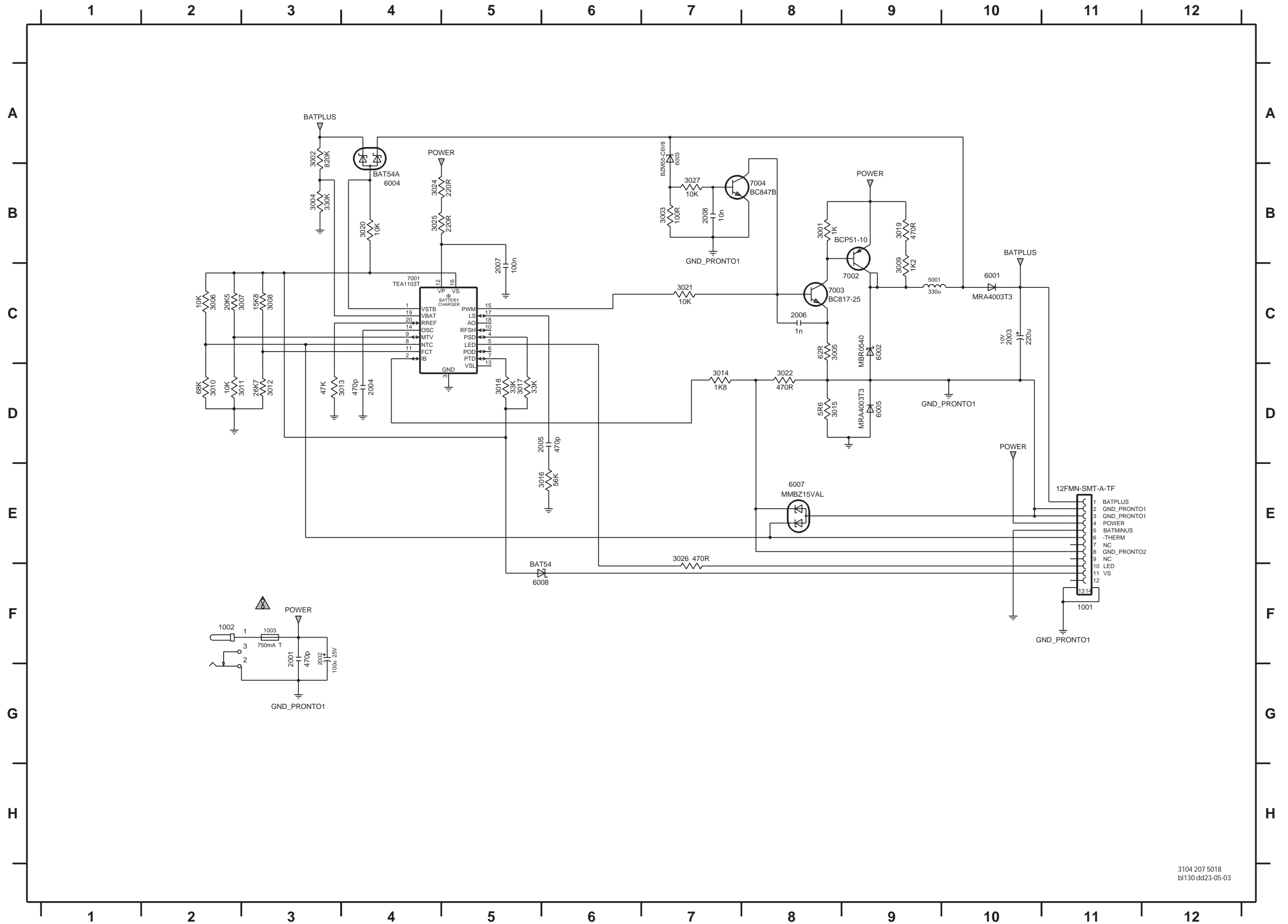

- 1001E 11
- 1002F 3
- 1003F 3
- 2001F 3
- 2002F 3
- 2003 C10
- 2004 D4
- 2005 D6
- 2006 C8
- 2007 C5
- 2008 B7
- 3001 B8
- 3002 A3
- 3003 B7
- 3004 B3
- 3005 C8
- 3006 C2
- 3007 C2
- 3008 C3
- 3009 C9
- 3010 D2
- 3011 D2
- 3012 D3
- 3013 D3
- 3014 D7
- 3015 D8
- 3016E 6
- 3017 D5
- 3018 D5
- 3019 B9
- 3020 B4
- 3021 C7
- 3022 D8
- 3024 B5
- 3025 B5
- 3026F 7
- 3027 B7
- 5001 C9
- 6001 C10
- 6002 C9
- 6003 A7
- 6004 A4
- 6005 D9
- 6007E 8
- 6008F 6
- 7001 C5
- 7002 B9
- 7003 C8
- 7004 B7

CHARGE BOARD - Component Layout

1001 A1	2008 B1	3010 C2	3020 C1	6002 B2
1002 B3	3001 B3	3011 C2	3021 B1	6003 B1
1003 B3	3002 B1	3012 C2	3022 B1	6004 B1
2001 B3	3003 B1	3013 C1	3023 C1	6005 B2
2002 B3	3004 B1	3014 B1	3024 B2	6007 B1
2003 B2	3005 B2	3015 B2	3025 B2	7001 C1
2004 C1	3006 C2	3016 C1	3026 C1	7002 B3
2005 C1	3007 C2	3017 C1	3027 B1	7003 B2
2006 B2	3008 C2	3018 C1	5001 B2	7004 B1
2007 B2	3009 B2	3019 B2	6001 B2	

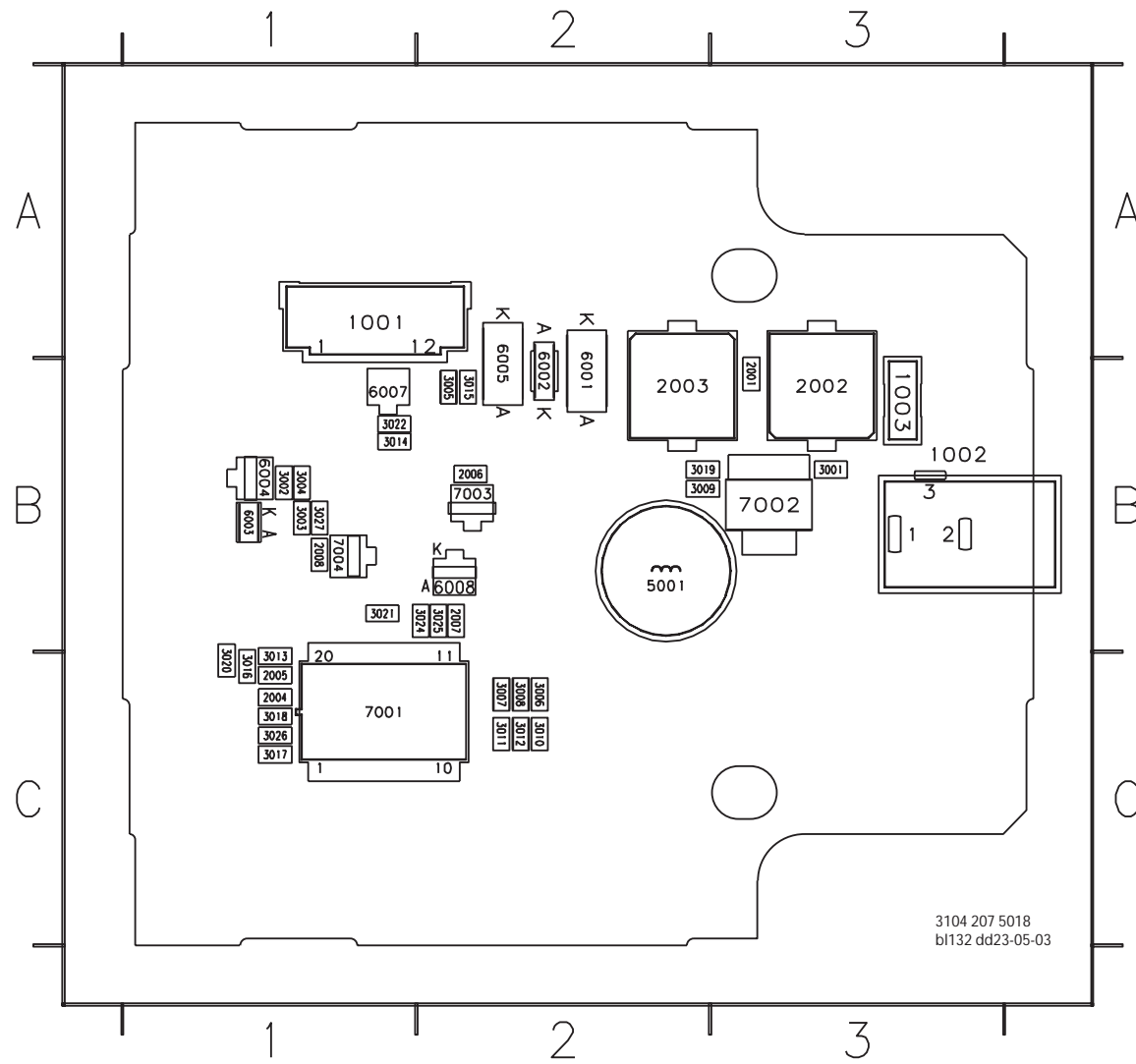

LED BOARD DIAGRAM & Component Layout

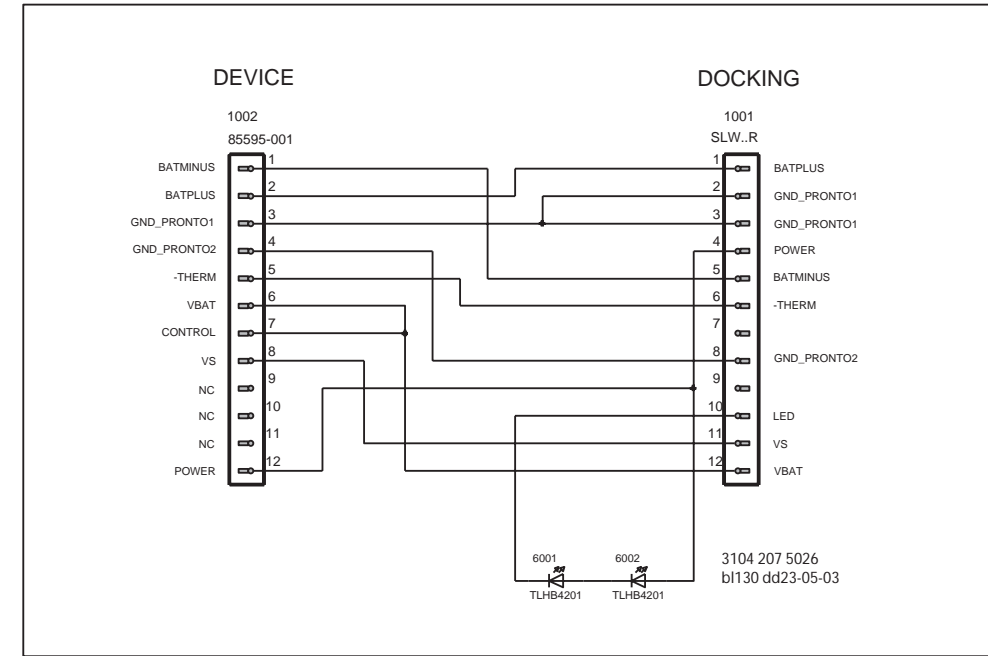

Component Layout

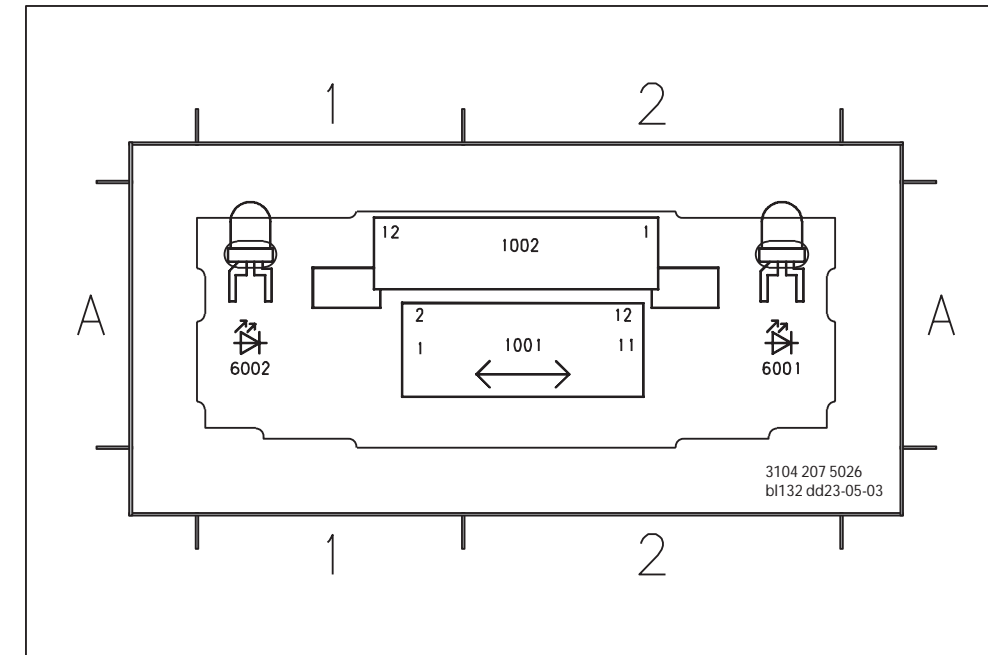

MECHANICAL & ELECTRICAL PARTS LIST - Docking Station DS5400

ELECTRICAL PARTS

1003 2422 086 11101	FUSE T750mA 125V UL
3104 207 14870	DOCKING STATION (3104 207 14420)
3104 207 14840	PRINTBOARD ASSY CONNECTOR (3104 207 40250)



DOCKING STATION



PRINTBOARD ASSY CONNECTOR

Note: Only the parts mentioned in this list are normal service parts

For more information:

E-mail: erik.gybels@philips.com

ELECTRICAL & MECHANICAL PARTS LIST- Docking Station DS5400**MECHANICAL PARTS**

22	3104 207 80530	TOPPART ASSY
23	3104 207 80540	BOTTOMPART ASSY
24	3104 204 18540	IR- WINDOW
28	3139 224 20710	RUBBER FEET

PRINTBOARD ASSY 3104 207 40150**MISCELLANEOUS**

1001	2422 025 17962	CON H 12P F 1.00 SM
1002	2422 026 03455	SOC SUPP H 1P M DC 2MM
1003	2422 086 11101	FUSE T 750MA 125V UL

CAPACITORS

2001	2238 586 15618	CER2 0603 50V 470P PM10
2002	2020 024 90669	ELCAP SM 25V 100U PM20
2003	2020 024 90677	ELCAP SM 10V 220U PM20
2004	2238 586 15618	CER2 0603 50V 470P PM10
2005	2238 586 15618	CER2 0603 50V 470P PM10

2006	2238 586 15623	CER2 0603 50V 1N PM10
2007	2238 916 19849	CER2 0603 25V 100N P8020
2008	2238 586 15636	CER2 0603 50V 10N PM10

RESISTORS

3001	2322 702 60102	RST SM 0603 RC21 1K
3002	2322 702 60824	RST SM 0603 RC21 820K
3003	2322 702 60101	RST SM 0603 RC21 100R
3004	2322 702 60334	RST SM 0603 RC21 330K
3005	2322 702 60629	RST SM 0603 RC21 62R

3006	2322 702 60103	RST SM 0603 RC21 10K
3007	2322 704 62053	RST SM 0603 RC22H 20K5
3008	2322 704 61583	RST SM 0603 RC22H 15K8
3009	2322 702 60122	RST SM 0603 RC21 1K2
3010	2322 702 60683	RST SM 0603 RC21 68K

3011	2322 704 61003	RST SM 0603 RC22H 10K
3012	2322 704 62673	RST SM 0603 RC22H 26K7
3013	2322 702 60473	RST SM 0603 RC21 47K
3014	2322 702 60182	RST SM 0603 RC21 1K8
3015	2322 702 60568	RST SM 0603 RC21 5R6

3016	2322 702 60563	RST SM 0603 RC21 56K
3017	2322 702 60333	RST SM 0603 RC21 33K
3018	2322 702 60333	RST SM 0603 RC21 33K
3019	2322 702 60471	RST SM 0603 RC21 470R
3020	2322 702 60103	RST SM 0603 RC21 10K

3021	2322 702 60103	RST SM 0603 RC21 10K
3022	2322 702 60471	RST SM 0603 RC21 470R
3024	2322 702 60221	RST SM 0603 RC21 220R
3025	2322 702 60221	RST SM 0603 RC21 220R
3026	2322 702 60471	RST SM 0603 RC21 470R

3027	2322 702 60103	RST SM 0603 RC21 10K
------	----------------	----------------------

FILTERS

5001	2422 536 00627	IND FXD 330U PM10 A
------	----------------	---------------------

DIODES

6001	9322 197 25668	DIO REC SM MRA4003
6002	9322 184 82685	DIO REC SM MBR0540
6003	9322 129 38685	DIO REG SM BZM55-C6V8
6004	9339 763 60215	DIO SIG SM BAT54A

6005	9322 197 25668	DIO REC SM MRA4003
6007	9322 168 12685	DIO REG SM MMBZ15VAL
6008	9337 422 80215	DIO SIG SM BAT54

TRANSISTORS & IC's

7001	9352 604 38118	IC SM TEA1103T_N2
7002	9339 172 80135	TRA POW SM BCP51-10
7003	9336 286 30215	TRA SIG SM BC817-25
7004	9335 895 90215	TRA SIG SM BC847B

PRINTBOARD ASSY 3104 207 40250**MISCELLANEOUS**

1001	2422 025 17146	CON H 12P F 1.00
1002	8204 161 43591	CON BM FCI-85595-001
8000	3104 200 51370	FLEXCABLE

DIODES

6001	9322 192 91676	LED VS TLHB4201
6002	9322 192 91676	LED VS TLHB4201